

CECW-EE Engineer Manual 1110-2-3200	Department of the Army U.S. Army Corps of Engineers Washington, DC 20314-1000	EM 1110-2-3200 30 September 1998
	Engineering and Design WIRE ROPE SELECTION CRITERIA FOR GATE-OPERATING DEVICES	
	Distribution Restriction Statement Approved for public release; distribution is unlimited.	

DEPARTMENT OF THE ARMY
U.S. Army Corps of Engineers
Washington, DC 20314-1000

EM 1110-2-3200

CECW-EE

Manual
No. 1110-2-3200

30 September 1998

Engineering and Design
WIRE ROPE SELECTION CRITERIA FOR GATE-OPERATING DEVICES

- 1. Purpose.** This manual provides information and criteria important to the selection, installation, and maintenance of wire rope and fittings. It applies primarily to gate-operating devices within the Corps of Engineers' responsibility.
- 2. Applicability.** This manual applies to all USACE Commands having civil works responsibilities.
- 3. General.** A unique problem facing the Corps is the wide variety of wire rope service conditions, which are determined by rope and hoisting equipment design, frequency of use, and the operating environments that exist at Corps installations. This manual covers many of these conditions and presents the latest state-of-the-art technology from commercial and industrial sources and information from existing Corps projects. Its purpose is to optimize the service life of wire rope and to reduce the likelihood of future failures.
- 4. Distribution Statement.** This manual is approved for public release; distribution is unlimited.

FOR THE COMMANDER:



ALBERT J. GENETTI, JR.
Major General, USA
Chief of Staff

20020628 205

**DEPARTMENT OF THE ARMY
U.S. Army Corps of Engineers
Washington, DC 20314-1000**

EM 1110-2-3200

CECW-EE

Manual
No. 1110-2-3200

30 September 1998

**Engineering and Design
WIRE ROPE SELECTION CRITERIA FOR GATE-OPERATING DEVICES**

Table of Contents

Subject	Paragraph	Page	Subject	Paragraph	Page
Chapter 1			Chapter 4		
Introduction			Optimum Design		
Purpose and Scope	1-1	1-1	Service Conditions and		
Applicability	1-2	1-1	Failure Modes	4-1	4-1
References	1-3	1-1	Calculating Rope Load	4-2	4-3
Distribution Statement	1-4	1-1	Sheaves	4-3	4-3
Wire Rope Failure, Service			Nominal Strength	4-4	4-4
Conditions, and This			Factor of Safety	4-5	4-4
Manual	1-5	1-1	Service Life	4-6	4-5
			Rope Length/Stretch	4-7	4-5
			Bending Radii	4-8	4-6
			Bearing Pressure	4-9	4-6
			Fleet Angle	4-10	4-7
Chapter 2			Chapter 5		
Rope Construction			Specifying Wire Rope		
and Materials					
Classification	2-1	2-1	Standard Nomenclature	5-1	5-1
Lay	2-2	2-3	Additional Requirements	5-2	5-1
Special Shaping of			Availability/Cost	5-3	5-2
Ropes/Strands	2-3	2-5	Buy American	5-4	5-3
Flat Rope	2-4	2-6			
Wire Materials	2-5	2-6	Chapter 6		
Core Materials	2-6	2-6	Field Acceptance		
Coating/Filling/Plating	2-7	2-7	and Installation		
Manufacturing	2-8	2-7	Field Acceptance	6-1	6-1
			Storage, Handling, and Unreeling ..	6-2	6-1
			Installation	6-3	6-1
Chapter 3			Chapter 7		
Sockets and End			Inspection, Maintenance,		
Terminations			Retirement, Etc.		
Sockets	3-1	3-1	Inspection	7-1	7-1
Materials/Coatings	3-2	3-2	Retirement	7-2	7-3
Drum and Miscellaneous					
Terminations	3-3	3-2			
Seizing/Cutting/Splicing	3-4	3-3			
Two-Piece Ropes	3-5	3-3			

EM 1110-2-3200
30 Sep 98

Subject	Paragraph	Page	Subject	Paragraph	Page
Lubrication	7-3	7-4	Appendix F		
Ice and Debris Removal	7-4	7-4	Kevlar Wire Rope		
Painting	7-5	7-4			
Cathodic Protection	7-6	7-5	Appendix G		
			Sample Inspection		
Appendix A			Report Checklist		
References					
			Appendix H		
Appendix B			Lubrication and Lubricant		
Glossary			Data		
Appendix C			Appendix I		
Nominal Strengths			Methods for Deicing		
and Testing					
			Appendix J		
Appendix D			Sample Problem		
Terminations and					
Efficiencies			Index		
Appendix E					
Test Links and Tension					
Limiting Devices					

Chapter 1 Introduction

1-1. Purpose and Scope

This manual provides information and criteria pertinent to the selection, installation, and maintenance of wire rope and fittings. It applies primarily to gate-operating devices within the Corps of Engineers' responsibility.

1-2. Applicability

This manual applies to all USACE Commands having civil works responsibilities.

1-3. References

The required and related publications are listed in Appendix A.

1-4. Distribution Statement

Approved for public release; distribution is unlimited.

1-5. Wire Rope Failure, Service Conditions, and This Manual

a. The Corps has recently experienced wire rope failures at a number of projects. These failures

prompted the development of this manual. Wire rope failures typically render gates inoperable causing delays to navigation, flooding potential, equipment damage, and possibly even personnel injury.

b. A unique problem facing the Corps is the wide variety of wire rope service conditions, which are determined by rope and hoisting equipment design, frequency of use, and the operating environments that exist at Corps installations. This manual covers many of these conditions and presents the latest state-of-the-art technology from commercial and industrial sources and information from existing Corps projects. Its purpose is to optimize the service life of wire rope, and to reduce the likelihood of future failures.

c. Chapters 2 and 3 present information on construction and materials for rope and fittings. Chapter 4 presents the calculations/data to select rope within engineering standards. Chapter 5 explains how to specify or order rope. Chapter 6 presents information on accepting and installing rope, and Chapter 7 covers inspection and maintenance.

Chapter 2 Rope Construction and Materials

Wire rope consists of multi-wire strands laid helically around a core (Figure 2-1). The way the wires are laid to form the strands, the way the strands are laid about the core, the core construction, and the materials and coatings used for the components contribute to the overall properties of the rope. The following sections discuss rope properties in regard to construction and materials. They do not cover all the available types of wire rope, but attempt to cover the types applicable to gate-operating devices.

2-1. Classification

a. Designation method. Wire rope classification is designated by the construction of the rope as seen in cross section. The number of strands and the number of wires in each strand are respectively given in its label, for example: 6x19, 6x37, 7x19, 8x61, etc. (Figures 2-2 and 2-3).

b. Strand configuration. Note that the nominal classifications may not reflect the actual construction. For example, the 6x19 classification includes 6x21 Filler Wire, 6x19 Seale, and 6x26 Warrington Seale constructions. The terms Filler Wire, Seale, Warrington, and Warrington Seale refer to the layers and the configurations of the strands (Figures 2-4 and 2-5). Note that for the Seale configuration, the wires in any layer of the strand are of equal diameter. For the Warrington configuration, the wires of the outer layer of the strand are of two different diameters. The Warrington Seale configuration is a blend of the Seale and Warrington configurations. The outer layer has equal diameter wires and the next layer inward has wires of two different diameters. For the Filler Wire configuration, all the main wires of each strand are of equal diameter like the 7-Wire configuration. However, extra wires of a small diameter have been added between the main wires. Compared to the 7-Wire configuration, the more complicated configurations result in strands which are more stable, flexible, and less likely to collapse under load.

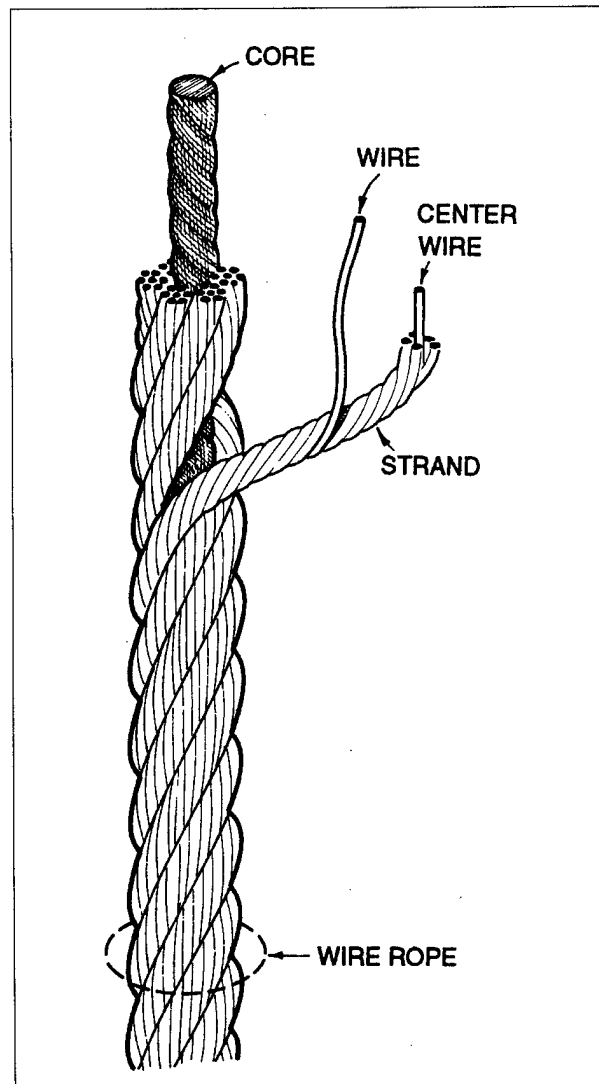

Figure 2-1. The three components of a typical wire rope

c. Rope properties. Important characteristics of wire rope relate to the number and size of the outer wires, and to a lesser extent, the inner wires. A small number of large outer wires results in better resistance to wear and corrosion. A large number of small wires results in better flexibility and resistance to fatigue. Section 4-6, "Service Life" gives data on rope classification versus service life. Figure 2-6 is referred to as the "X-chart" by the wire rope industry. It shows an inverse relationship between abrasion resistance

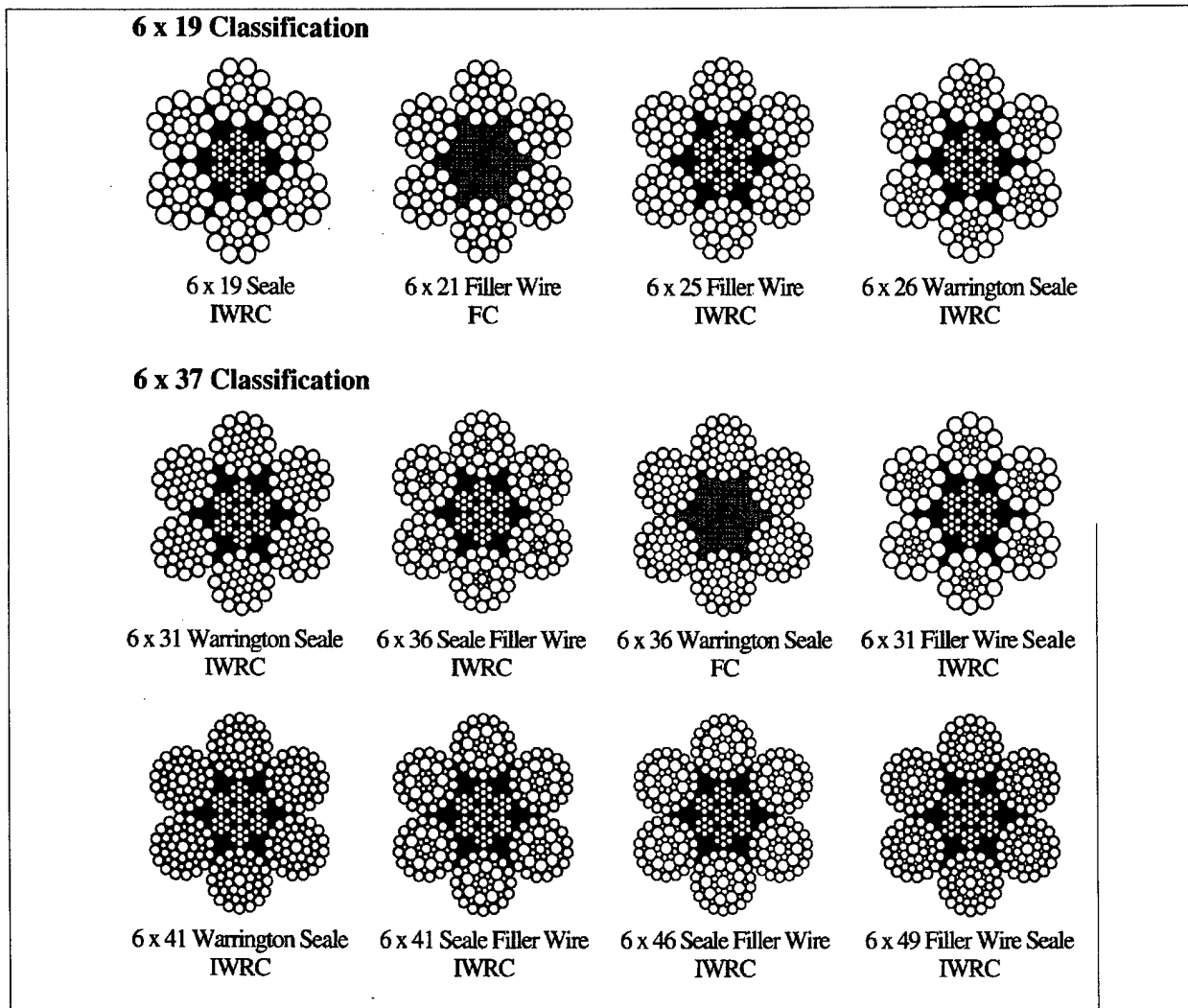

Figure 2-2. Six-strand classes

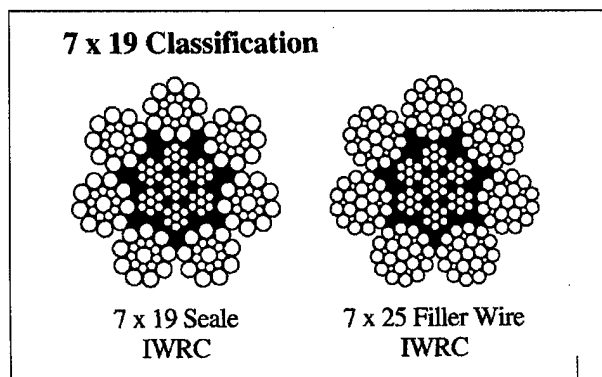

Figure 2-3. Seven-strand classes

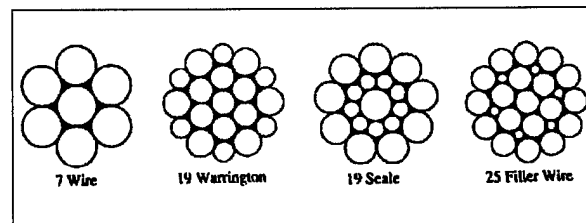

Figure 2-4. Basic strand patterns

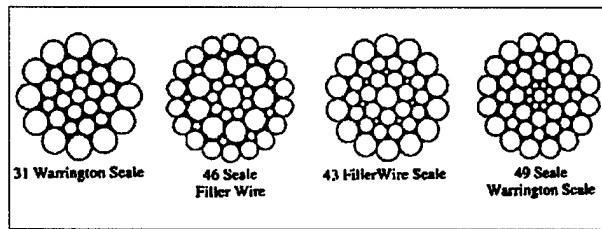

Figure 2-5. Combination strand patterns

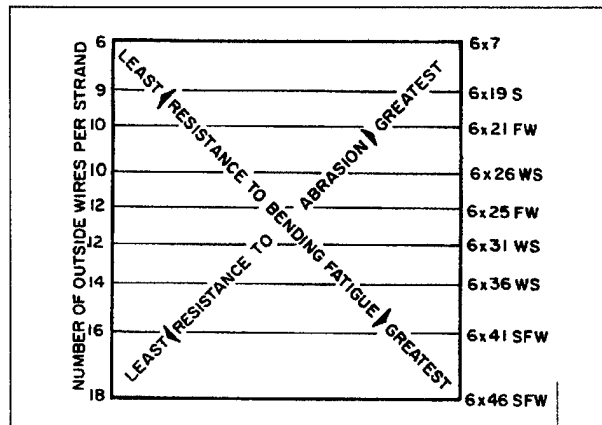

Figure 2-6. The X-chart as referred to by the wire rope industry

and resistance to bending fatigue for some widely used wire rope constructions. For many installations, both wear and fatigue may be a concern, which would require a compromise. Engineering judgment in considering the application is needed to determine the trade-off between fatigue resistance and wear resistance. Strength also varies somewhat with classification and is shown in Appendix C. Note that just as the classification (number of strands x number of wires per strand) is a relative indication of wire size, so is strand configuration. For example, a strand of the Filler Wire configuration will likely have some wires of a much smaller diameter than any of the wires in a strand of the Seale configuration.

d. Classifications for gate-operating devices. It is impossible to present here an all-inclusive list of wire rope classifications suitable for gate-lifting devices. However, 6x37 has long been considered appropriate by most manufacturers for lifting devices. Past guidance for Tainter gate design called for 6x25 type B flattened strand rope. Gate-lifting devices have frequently used 6x37 Fiber Core (FC) and 6x30

Independent Wire Rope Core (IWRC). This does not suggest that any of these classes will be the best engineering choice for any particular device, but they would normally be among the first ones considered in the engineering analysis. Note that in considering the initial selection, it may be wise to keep wires in a manageable size. That can be done by considering both construction and strand configuration. In regards to construction, if a device uses a very small diameter rope, say 16 mm (5/8 in.), initially consider a construction such as 6x7. If a device uses a medium diameter rope, say 32 mm (1-1/4 in.), initially consider a construction such as 6x19. If a device uses a large diameter rope, say 64 mm (2-1/2 in.), initially consider a construction such as 6x37. In this way, a small rope would have relatively large wires and large rope would have relatively small wires. The wires tend to be relatively constant in size through a large range of rope size. The characteristics of the wires in regards to abrasion and corrosion would be similar. In regards to strand configuration, note that strands with a Warrington Seale configuration have relatively small inner wires. This configuration may be appropriate for a large rope, say 52 mm (2 in.). However, strands with a Seale configuration have relatively large inner wires which may be more appropriate for a small rope, say 26 mm (1 in.). Again, but to a lesser extent, the wires tend to be relatively constant in size through a range of rope size. Finally, note that the Filler Wire strand configuration is not applicable for rope for gate-lifting devices. This is because its filler wires are so relatively small, that even in very large ropes, their absolute size is too small. The small wires are unsatisfactory because of corrosion concerns.

2-2. Lay

a. Designation method. The lay of a wire rope is designated by direction and type (Figure 2-7). Direction is right or left according to how the strands have been laid around the core. The lay type is either regular or lang, depending on whether the wires in the strands are laid in the opposite direction of the strands or the same direction as the strands.

b. Right versus left lay. Right lay rope is standard. If lay direction is not designated, right lay

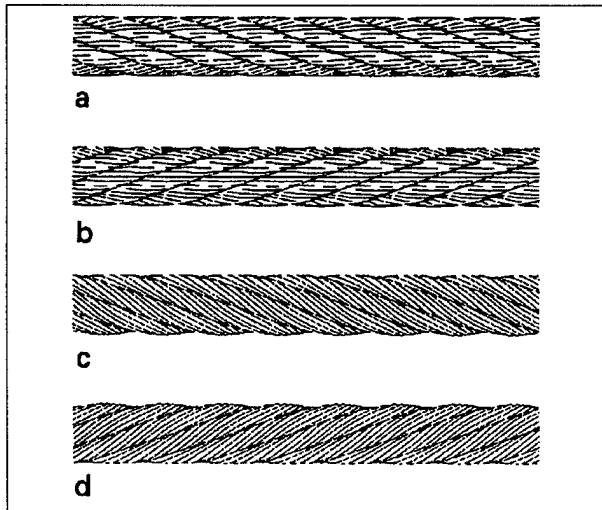

Figure 2-7. Direction and type of lay: (a) right regular lay, (b) left regular lay, (c) right lang lay, and (d) left lang lay

drum. If the correct lay is not used in this case, the rope will not wind smoothly against its previous wrap.

c. Regular lay versus lang lay. The wires in regular lay wire rope appear to line up with the axis of the rope. In contrast, the wires in lang lay wire rope appear to form an angle with the axis of the rope. Regular lay wire rope is used for the widest range of applications. It has a somewhat better resistance to crushing than lang lay wire rope and does not rotate as severely under load when used in an application where either end of the rope is not fixed. Lang lay wire rope has two important advantages. It has better resistance to both fatigue and abrasive wear. Lang lay rope has a longer exposed length of exterior wires. Bending of lang lay rope results in less axial bending of the outer wire, but greater torsional flexure. Overall, lang lay wire rope displays a 15 to 20 percent superiority in service life over regular lay when bending is the principal factor affecting service life. Also, because of the longer exposed length of the exterior wires, the ropes are exposed to less pressure which decreases the rate of abrasive wear on wires, drums, and sheaves (Figures 2-8 through 2-10). There is no difference in breaking strength between lang and regular lay rope.

d. Rope lay in Corps applications. Most of the wire rope used for Corps gate-operating devices is of



Figure 2-8. The difference in wear characteristics of lang lay and regular lay ropes

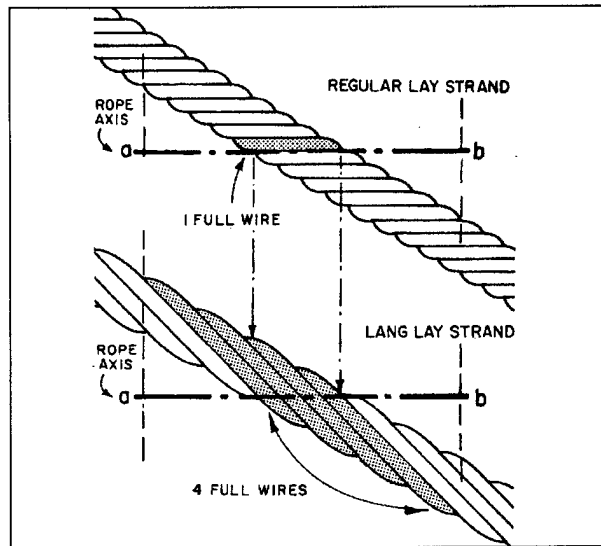

Figure 2-9. Wire direction of lang versus regular lay rope

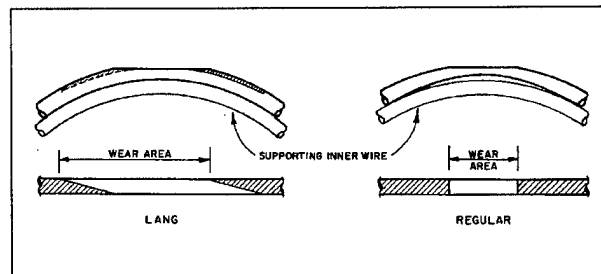

Figure 2-10. Bearing/wear areas of lang lay versus regular lay rope

the regular lay type. However, many installations would be better served with lang lay ropes. A lang lay replacement should be considered for any regular lay wire rope which has failed due to wear or fatigue.

Lang lay wire rope is potentially more prone to kinking and underlaying or opening up. Therefore, a rope tensioning device such as a turnbuckle may be appropriate on gates where lang lay ropes are used.

2-3. Special Shaping of Ropes/Strands

a. General. Manufacturers vary rope from the standard round wire and round strand configurations to enhance some of its properties. The variations covered in this section are (1) compacted strand wire rope, (2) swaged (compacted) wire rope, and (3) flattened strand (triangular) wire rope (Figures 2-11 through 2-13). Manufacturers should be consulted when specifying specially shaped rope to verify that all the characteristics of the special shape are consistent with the needs of the application.

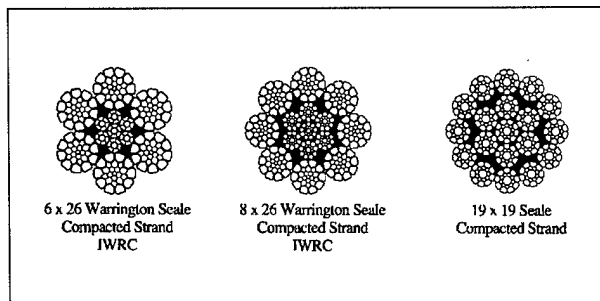

Figure 2-11. Compacted strand wire rope cross sections

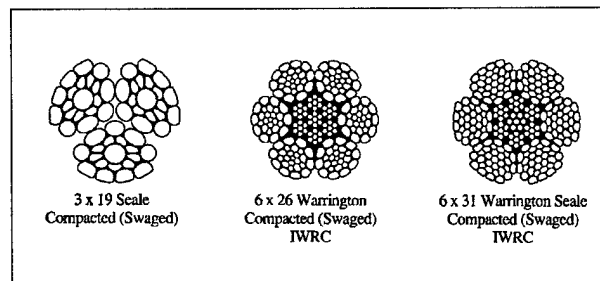

Figure 2-12. Compacted wire rope cross sections

b. Compacted strand wire rope. Compacted strand wire rope is manufactured from strands which have been reduced in diameter by one of several swaging processes. The outer surfaces of the outer strand wires are flattened and the internal wires are no

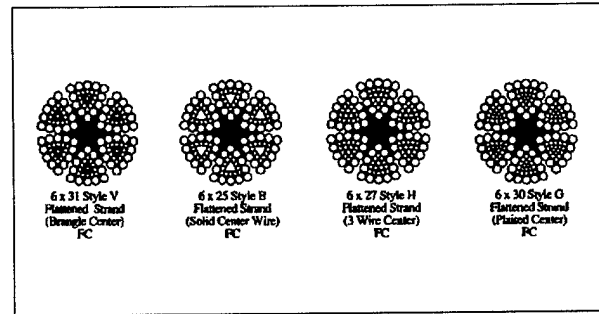

Figure 2-13. Flattened strand wire rope cross sections

longer round. Compared to a standard wire rope of the same diameter, a rope of the compacted strand configuration has a greater cross-sectional area of metal. This results in higher strength and less resistance to fatigue. It has a smoother surface which makes it more abrasion resistant, but it is less corrosion resistant for two reasons. First, its smoother surface is less able to hold lubrication. Second, the swaging process used to form the strands is not compatible with stainless steel, which is the material of choice for corrosion resistance.

c. Swaged (compacted) wire rope. A standard IWRC wire rope is used to form compacted wire rope. Its entire cross section is reduced in diameter, usually by rotary swaging. Compared to a standard wire rope of the same diameter, it has a greater cross-sectional area of metal and flatter wires on the outer surface. The smooth outer surface provides good wear resistance. It is also stronger and more resistant to crushing, but fatigue life is reduced by the compacting process. Like compacted strand rope, it is less corrosion resistant for the same reasons.

d. Flattened (triangular) strand wire rope. Flattened strand wire rope features strands which are triangular in shape. The center of the strands consist of either a triangular-shaped wire or of wires laid in a triangular configuration. Compared to a standard wire rope of the same diameter, it has a greater cross-sectional area of metal and an increased bearing surface. Strength, abrasion resistance, and resistance to crushing are enhanced with the flattened strand configuration. Fatigue resistance is unaffected. Flattened strand wire rope can be obtained with either FC or IWRC and is usually furnished in lang

30 Sep 98

lay. This variation is compatible with stainless steel, which makes it the most useful of the special shapes for gate-operating devices.

2-4. Flat Rope

A number of older Corps installations use flat wire rope for gate-operating devices. Flat rope is always layered over its drum and has generally provided satisfactory service. However, it is expensive to manufacture and requires a long lead time. Expertise in fabricating flat rope is no longer available. When flat rope is retired, it is normally replaced with round rope, along with modifications to the hoisting equipment. See Section 5-3, "Availability/Cost."

2-5. Wire Materials

a. Steels.

(1) Carbon steels. The grades of carbon steel wire rope are Traction Steel (TS), Plow Steel (PS), Improved Plow Steel (IPS), Extra Improved Plow Steel (EIPS), and Extra Extra Improved Plow Steel (EEIPS). Of these, only EIPS and EEIPS are normally specified for gate-operating devices. TS is normally used for elevators. PS and IPS ropes are nearly obsolete and are seldom stocked or fabricated by manufacturers. EIPS is much stronger than TS and has similar toughness. EIPS carbon steel rope is stronger than the stainless steels and has better resistance to abrasive wear.

(2) Stainless steels. Of the stainless steels available, only types 302 and 304 have been used regularly on gate-operating devices. Any other stainless steels would be experimental. A 10 to 15 percent loss of strength is typical compared to the IPS and better carbon steels. Stainless steels are not as resistant to abrasive wear and are susceptible to galling when layered over sheaves. Since they are not magnetic, inspection by the electromagnetic (non-destructive) method is not possible. The stainless steels are many times more corrosion resistant than the carbon. However, it is important to note that the stainless steels have a different galvanic potential than the carbon steels. When using stainless steel rope, it is possible to set up a galvanic corrosion cell in which carbon steel sockets, rope fittings, or

other equipment rapidly corrode. See Sections 3-2, "Materials/Coatings and 7-6, "Cathodic Protection."

b. *Brass/bronze/monel.* The non-ferrous metals are more corrosion resistant in salt water than the steels but are susceptible to rapid abrasion. They would rarely be applicable for Corps of Engineers gate-operating devices.

c. *Kevlar.* At Corps installations where the water has proven to be very corrosive to the submerged portions of wire ropes, Kevlar replacement ropes have given satisfactory results. Kevlar's properties are very different from steel for abrasion resistance, crushing resistance, and elasticity. Kevlar wires are very susceptible to abrasion damage and they must be protected with a jacket, usually of a polyethylene material. The jacket reduces the usable cross section of the rope, but a jacketed Kevlar rope has about the same breaking strength as a stainless steel rope of the same diameter. This strength makes it possible to attain normal factors of safety with Kevlar replacement ropes. Because of the jacket, inspection is difficult compared to bare metal wire rope. However, a change in appearance does occur prior to failure. Kevlar rope, when used with multiple layered type drums soon crushes from a round shape to an almost square shape, but does not lose its integrity. Kevlar rope stretches about two times as much as steel under a full load. Therefore, it stores more energy and a rope breakage will release more energy. A higher degree of personnel protection should be considered where Kevlar rope is used. (See Appendix F for information on Kevlar rope.)

2-6. Core Materials

a. *General.* As previously stated, wire rope consists of multi-wire strands laid helically around a central core. The core contributes very significantly to the overall properties of the rope. There are two types of cores, Fiber Core (FC) and Independent Wire Rope Core (IWRC).

b. *Fiber core (FC).* The core in FC wire rope provides no real strength for either crushing or tension. The fiber tends to dampen out vibration, an advantage for some applications, such as elevators. FC is more flexible than IWRC, but flattens under

load, inhibiting the free internal adjustment of the wires, which increases stresses. In the past it was thought that its core had a significant lubricant holding ability. That is not presently considered a real advantage. FC wire rope is not well suited for gate-lifting devices.

c. Independent wire rope core (IWRC). The advantages of IWRC are its strength in tension and its resistance to crushing. Its only disadvantage is decreased flexibility. Since bending around drums and sheaves at high loads is required for most gate-operating devices, IWRC wire rope is generally preferred for these applications.

2-7. Coating/Filling/Plating

a. General. In general, galvanized carbon steel rope is the only plated, filled, or coated metal rope suitable for gate-operating devices at Corps installations. The plastic-filled and plastic-coated ropes have certain disadvantages in regards to corrosion and inspection.

b. Plastic-filled. Plastic-filling helps prevent abrasion as the individual wires move relative to each other. However, concentrated corrosion cells will form at the exposed wires in a wet environment making plastic-filled rope unsatisfactory for gate-operating devices.

c. Plastic-coated. Plastic-coated rope is difficult to inspect. Also, the coating soon wears off making it similar to a plastic-filled rope.

d. Galvanized steel. Galvanized carbon steel rope can be manufactured in several ways. It can be weaved from either galvanized rope wire or from drawn galvanized rope wire. Galvanized rope wire is zinc-coated to the finished diameter by either the hot dip process or by the electro-deposition process. Since the diameter of the steel wire is reduced, and the zinc has little strength, a wire rope galvanized in this manner has about a 10 percent reduction in strength compared to one of bare steel. Drawn galvanized rope wire is zinc-coated, by either the hot dip process or by the electro-deposition process, before its last drawing operation. A wire rope galvanized in this manner has the same strength as one of bare steel. It is also

possible to zinc-coat a rope after weaving. A rope galvanized in this manner would have no reduction in strength compared to one of bare steel. Either of the last two galvanizing methods would be preferable to the first for gate-operating devices. Galvanized carbon steel rope is generally very corrosion resistant compared to bare carbon steel rope, at least until the zinc coating disappears. Rate of zinc loss can be very high in industrial areas because of airborne pollution. Galvanized rope is much lower in cost than stainless steel (See Section 5-3, "Availability/Cost"). It is also stronger than stainless steel if manufactured from drawn galvanized rope wire. In addition, it is less susceptible to damage from nicks and does not have the galling problems of stainless steel.

2-8. Manufacturing

This section presents information on various rope manufacturing processes.

a. Stress relief. Newly woven wire rope is normally run through molten lead to relieve stresses in the wires resulting from the various drawing, preforming, and swaging processes. If not stress relieved, the fatigue life of the rope is shortened.

b. Pre-stretching. Wire rope normally stretches more rapidly when new than it does as it ages. Pre-stretching is an operation which takes most of the initial stretching out of the rope. It can be accomplished economically if performed in conjunction with socketing. Pre-stretching is recommended for installations with multi-rope drums, where the ropes need adjustment for equal tension. If pre-stretching is not performed, the ropes may tend to stretch unequally in use and may need to be periodically re-adjusted. See Sections 6-3, "Installation" and 4-7, "Rope Length/Stretch." The normally accepted procedure for pre-stretching wire rope is as follows. The rope is subjected to three cycles of tensile loading to 40 percent of its nominal strength. The 40 percent loads are held for 5 minutes with 5 percent loads between cycles. There is no standard yet established for dynamic pre-stretching, but there may be in the future. This has been performed by tensioning a rope at 20 percent of its nominal strength while operating over pulleys. This process appears to be difficult to specify, but it may be an option to consider.

30 Sep 98

c. Weaving. The whole weaving process is somewhat of an art as far as wire shaping, preforming, determining the exact wire sizes and spool rotation, and performing welding methods. Including weaving criteria in specifications may be very difficult.

d. Blending wires. Manufacturers occasionally mix stronger wires in with weaker wires (in the same rope) in order to meet minimum acceptance strength requirements. This is common and usually does not present a problem to the buyer. Although the resulting blend meets the required strength criteria, the stronger wires may be less fatigue resistant than the weaker ones and may potentially cause the rope to degrade faster if its prime failure mode is fatigue. If the wire properties are more uniform, that is, if they are of the same strength and meet a minimum ductility requirement, the potential of a fatigue failure may be postponed, increasing service life. Standard

procedures for strength testing rope wires for ductility (torsion) are included in Appendix C. Note that the cost of a rope may increase if the wires are required to have both a minimum strength and a minimum ductility.

e. Preforming. Almost all wire rope sold in the United States have preformed wires. Preforming methods differ with different manufacturers. Preforming is normally performed, even if not specified by the buyer. It should be included as a requirement in the rope specifications. Wire rope without preformed wires has tendency to unravel, especially if any individual wires break. Rope with preformed wires has greater flexibility, and it spools more uniformly on a drum. Preforming also provides a better distribution of the load to every wire which improves fatigue resistance and flexibility.

Chapter 3 Sockets and End Terminations

Sockets and end terminations are of great importance in regards to efficiently transferring force from the drum, through the wire rope, and to the gate. They can have a significant effect on the service life of a rope. Each type of socket or termination has its individual characteristics, and one type will usually fit a given installation better than the others. Their strength varies and not all will develop the full strength of the rope (See Section 4-5, "Factor of Safety"). This chapter presents various sockets, drum terminations, and miscellaneous terminations along with information on cutting and splicing wire rope. This chapter also presents information on the option of using two-piece ropes.

3-1. Sockets

a. General. Sockets are normally used at the gate end of a wire rope, and they must develop 100 percent of the strength of the rope. It should be noted that sockets are not normally reused.

b. Swaged sockets. Swaged sockets are mechanically pressed onto wire rope (Figure 3-1). They are occasionally used for gate-operating devices. If properly designed and attached, they can develop 100 percent of the strength of the rope. Note that swaged sockets are not suitable for lang lay rope, nor are they suitable for ropes with a fiber core.

c. Speltered sockets. Speltered (or poured) sockets are attached to wire rope with zinc or resin (Figure 3-2). They are normally specified for the gate end of a rope. They are best where the rope is in straight tension, that is, where the load does not touch the rope (Figure 3-3). Both zinc-filled and resin-filled sockets develop 100 percent of the strength of the rope if attached correctly. In fact, speltered sockets are normally used for wire rope strength testing. Zinc fill is the old standard. However, epoxy fill appears to be better in almost every respect. Also, it is recommended that speltered sockets be proof loaded prior to use.

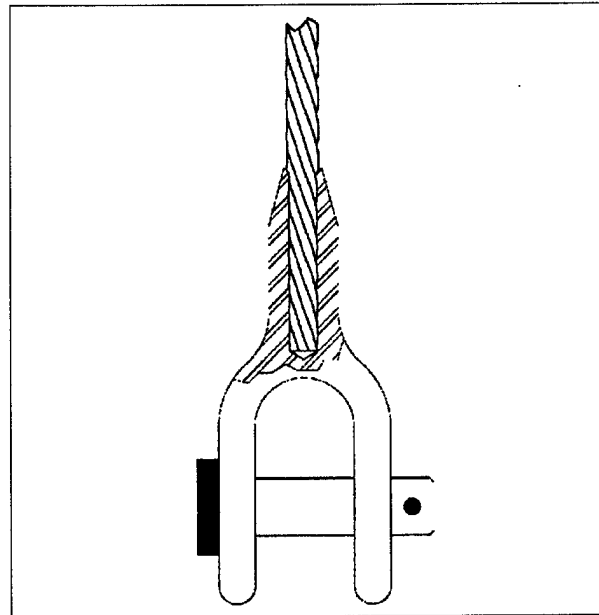

Figure 3-1. A swaged socket: Like speltered sockets, they can develop 100 percent of rope strength

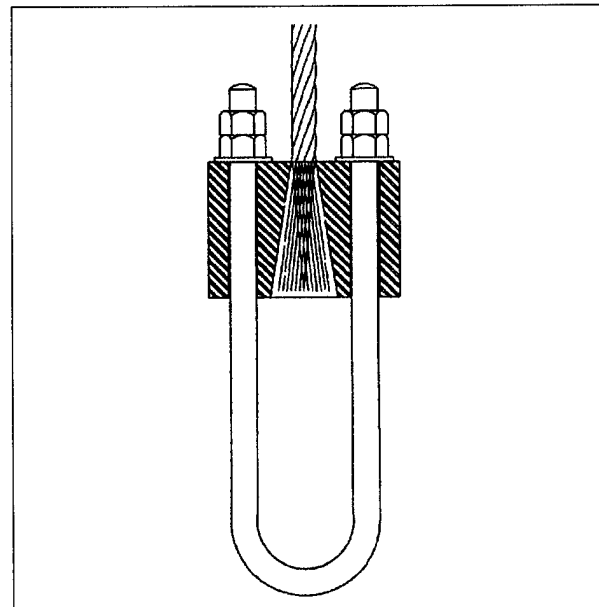

Figure 3-2. A speltered socket: This type socket can develop 100 percent of the strength of a wire rope

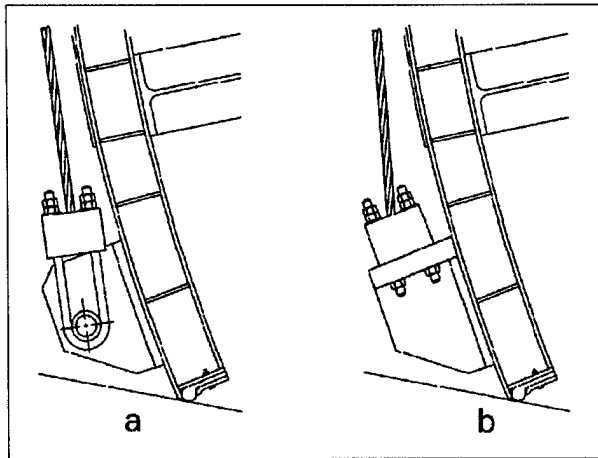

Figure 3-3. Wire rope should be in straight tension out of a socket: (a) correct - socket can rotate, and (b) incorrect - rope is required to bend

d. Installation. It is recommended that swaged and spltered sockets be attached at the rope manufacturer's facilities. Swaged sockets are frequently installed by the rope manufacturer as qualified personnel, proper dies, and heavy hydraulic presses are required. A great deal of expertise is needed for attaching both swaged sockets and spltered sockets. The rope must be well aligned with the socket and the rope strands must have uniform tension. In attaching spltered sockets, cleaning before pouring zinc or epoxy can be difficult in the field. Poor cleaning can result in a weak socket. Also, the proof loading with sockets in place prior to use is more readily accomplished at a rope manufacturer's facilities. Although socketing is best left to experts, note that socketing information is presented in the Wire Rope Users Manual. Also note that some sockets for gate-lifting devices are a custom design.

3-2. Materials/Coatings

If swaged or spltered sockets and their ropes are of dissimilar materials, and are located under water or in wet environments, they will likely fail from galvanic corrosion. The designer/specifier must consider materials and coatings in regard to selection of the sockets for wire rope. It is important that the socket and splter material are galvanically compatible with the rope. That is, they all need to have approximately the same galvanic potential. A stainless steel rope

attached to an epoxy-filled spltered socket of a compatible stainless steel width would be ideal, as would a galvanized rope attached to a galvanized steel spltered socket. Coatings can be used to protect the more reactive element of the rope/socket combination but are not recommended. Sockets can be coated with insulating materials, either on the inside for galvanic isolation from the rope or on the outside for protection from the environment. However, coatings are susceptible to problems from poor installation and damage from nicks, cuts, and wear. Additionally the designer/specifier should consider the materials for pulleys or gate areas in contact with the rope. A submerged carbon steel pulley in contact with a stainless steel rope will probably pit, and may cause significant abrasive wear to occur on the rope.

3-3. Drum and Miscellaneous Terminations

a. Drum anchorages. Most drum anchorages for gate-operating devices feature bolt-on-clamps or wedge-type sockets. They are usually designed by the drum/equipment manufacturer. Alone, their efficiency may not be as high as required, but in combination with at least two dead wraps of the rope, and preferably three, they should develop 100 percent of the strength of the rope (Figure 3-4). This is true for grooved, plain, and multiple layered drums (Appendix D).

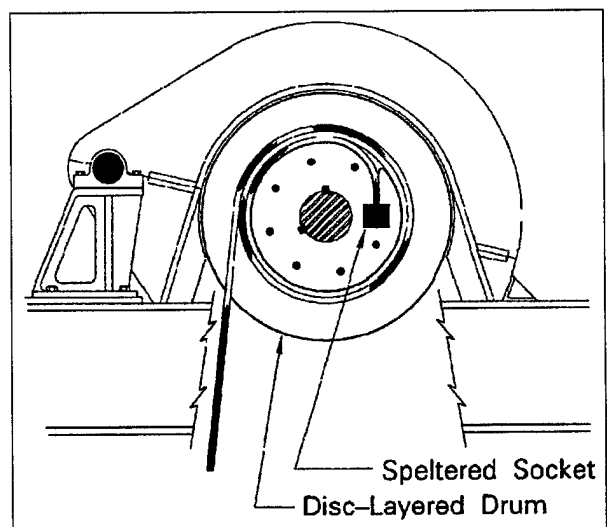

Figure 3-4. Drum anchorages featuring clamps will develop 100 percent the strength of the rope, if two or preferably three dead wraps are made

b. Miscellaneous terminations. There are a number of end terminations which are less efficient than swaged sockets, speltered sockets, and drum anchorages. They include clamps, clips, wedge sockets, etc. Their use on gate-operating devices is not recommended because of their lower efficiencies, which generally range between 70 and 80 percent (Figure 3-5 and Section 4-5, "Factor of Safety"). Also note that most of these type fittings should not be reused as a rope's wires will swage into their metal mating surfaces. They only provide the proper rope grip during the first use.

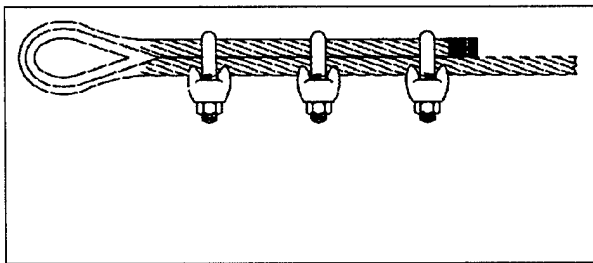

Figure 3-5. A clamped termination

3-4. Seizing/Cutting/Splicing

a. General. Seizing, cutting, and splicing wire rope, except at the rope manufacturer's facilities, is discouraged. This is especially true for splicing. However, there may be times these procedures must be performed in the field.

b. Seizing. Proper seizing is required prior to cutting wire rope. The seizing must be placed on each side of the cut. Failure to adequately seize a rope will result in problems such as loosened strands, distorted and flattened ends, and eventual uneven load distribution. Information on methods of seizing is given in the Wire Rope Users Manual.

c. Cutting. Cutting is reasonably simple if the proper tools are used. There are several types of

cutters and shears commercially available which are specifically designed to cut wire rope. Although it is a common practice, wire rope should not be cut with a torch.

d. Splicing. Splicing is not a recommended practice for gate-operating devices. The efficiency of a spliced rope is likely to be very low. Information on splicing is given in the Wire Rope Users Manual.

3-5. Two-Piece Ropes

There are potential benefits for using two-piece ropes for some applications. For example, an existing carbon steel wire rope on a gate-lifting device may occasionally or usually be submerged at its gate end. The gate end will normally corrode severely, but the rest of the rope will not. The existing one-piece rope could be replaced with a two-piece rope. The longer upper section would be attached to the drum. It would always be above the water line, and would provide a long service life even if made of carbon steel. A shorter section would be used for the gate end. If the shorter section could be made of carbon steel, it would be replaced often, but at a much lower cost than replacing the previous one-piece rope. Another option would be to make the short piece of stainless steel. This would provide a longer service life at a lower overall cost than a one-piece stainless steel wire rope. It is recommended the connection between the two ropes be designed for replacement without having to re-socket the rope attached to the drum. It is also recommended the upper rope section be long enough so the connection does not contact the drum or sheaves when the gate is in the fully open position. Purchasing more than one gate-end rope per drum-end rope should be considered. The major disadvantage to the two-piece rope concept would be the cost for extra sockets and socketing.

Chapter 4 Optimum Design

The following six properties must be considered when selecting a wire rope:

- a. Resistance to breaking.
- b. Resistance to fatigue.
- c. Resistance to abrasive wear.
- d. Resistance to crushing.
- e. Resistance to corrosion.
- f. Reserve strength.

This chapter contains information that will help the designer/specifier evaluate each property to obtain an optimum design.

4-1. Service Conditions and Failure Modes

All wire rope in permanent service will eventually fail. Its mode of failure depends on the conditions under which it operates. Gate-operating devices at Corps facilities use various combinations of different types of drums, sheaves, and guides. The gates that the devices operate are located over a wide geographical area in differing environments. Rope service conditions as determined by the design of the rope handling equipment, the frequency of use, and the environment vary greatly. This section presents general information on rope service conditions, failure modes, and additional considerations for selecting new or replacement rope.

a. Rope handling equipment.

(1) Drums. Mechanically operated gate-operating devices generally use grooved, smooth, or disk-layered cylindrical drums to transmit power to the wire rope (Figure 4-1). The grooved type drum provides the best conditions for the rope since the grooves prevent the rope from rubbing against itself. However, for good service life, the pitch and diameter of the grooves, the fleet angle, the anchoring system, and the nominal

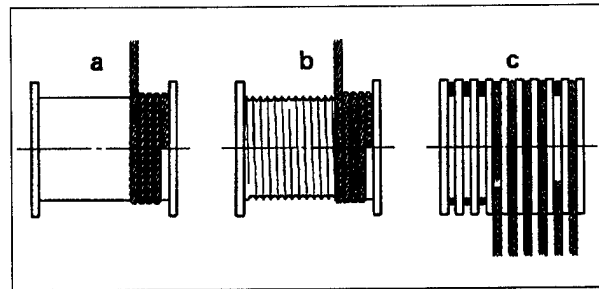

Figure 4-1. Drum types: (a) smooth, (b) grooved, and (c) disk-layered

diameter of the drum must all be correct for the size and type of rope. The plain type drum requires the rope to wind tightly against the preceding wrap causing the rope to abrade against itself. The disk-layered type drum requires the rope to be wrapped over itself in multiple layers. The rope is exposed to a much higher level of crushing and abrasion. A number of older Corps facilities have devices which use flat rope which always uses disk-layered drums.

(2) Sheaves and rollers. Some gate-operating devices use sheaves to multiply rope force or guides to change direction. Sheaves can be single or multiple on a single shaft. The layout and the type of bearings they use (plain or roller) determine the rope tension required to lift a given load (Section 4-2, "Calculating Load"). Sheave diameter, groove diameter, and condition all effect the wire rope rate of wear and fatigue. Cylindrical roller guides are also occasionally used on gate-operating devices. As with sheaves, their nominal diameter, groove diameter, and condition affect rope wear and fatigue.

b. *Rope failure modes.* A wire rope typically experiences any one or a combination of corrosion, fatigue, abrasive wear, and excessive stress. The following sub-paragraphs comment on each condition.

(1) Corrosion. The Corps has some facilities with gates which are not operated during normal hydrologic years, except when "exercised" for operation and maintenance (O&M) purposes. Fatigue and abrasive wear of the wire ropes is of little concern. The eventual expected failure mode at these facilities would normally be corrosion. There are also projects where corrosion, fatigue, and abrasion are all a concern. The prime failure mode depends on the

type of wire rope selected. Corrosive environments include:

(a) Submersion in fresh water, which may contain damaging substances such as chlorides, nitrates, calcium carbonates, bacteria, etc. Rope wires may be exposed to oxygen depleted areas, biological attack, and galvanic currents.

(b) Exposure to damp atmosphere either continuously or periodically, including rope in storage, with a potential for fungal induced corrosion.

(c) Exposure to airborne salt. Galvanized carbon steel, stainless steel, and Kevlar ropes have been used for their resistance to corrosion. Lubrication can have either positive or negative effects (Section 2-5, "Wire Materials" and Section 7-3, "Lubrication").

(2) Fatigue. Fatigue usually results from contact with sheaves and drums. Rope moving over drums, sheaves, and rollers is subjected to cyclic bending stresses. Stress magnitude depends on the ratio of the tread diameters of the drums and sheaves to the diameter of the rope. Fatigue is also affected by lubrication and the condition of the surface over which the rope is bending. In order to bend around a sheave, the strands and wires of a rope must move relative to one another. This movement compensates for the difference in diameter between the underside and top side of the rope. Lack of rope lubrication or excessive pressure caused by too small of groove diameter limits wire slip. This increases bending and fatigue. Some devices require rope to change bending direction from drum to sheave, or from one sheave to another. Reverse bending further accelerates wire fatigue. Wire rope featuring lang lay construction and small wires tends to be effective in reducing fatigue (Sections 2-1, "Classification," 4-6, "Service Life," 4-8, "Bending Radii," and 7-3, "Lubrication").

(3) Abrasive wear. Wear from abrasion, like fatigue, normally results from contact with sheaves and drums. Wire rope, when loaded, stretches much like a coil spring. When bent over a sheave, its load-induced stretch causes it to rub against the groove. As a result, both the rope and groove are subject to abrasion. Within the rope, wires and strands move relative to each other, and additional abrasion occurs.

Excessive abrasion can be caused by the sheave or drum being of too soft of a material, or having too small of a tread diameter. Other factors include too much rope pressure, an improper groove diameter, or an improper fleet angle. Movement of rope against roller guides can cause excessive abrasion. Improper tensioning can allow rope to rub against metal or concrete structures. Wire rope featuring lang lay construction and large wires tends to be effective in reducing abrasive wear (Sections 2-1, "Classification," 4-6, "Service Life," 4-8, "Bending Radii," and 7-3, "Lubrication").

(4) Excessive stress. Excessive stress in Corps applications has generally resulted from attempted operation when a gate is inoperable because of ice and debris or gate misalignment. To some extent, safety devices to limit rope tension can reduce the probability of a failure (Section 7-4, "Ice and Debris Removal"). Excessive stress can result from improper tensioning in a device using multiple ropes (Section 6-3, "Installation").

a. Additional considerations. The wire rope at existing Corps installations will eventually need to be replaced. The retired rope and fittings should be inspected and analyzed to determine the prime distress mode (fatigue, abrasive wear, corrosion, or excessive stress). U.S. Army Construction Engineering Research Laboratories (CERL) can provide assistance in this determination. This should be considered in the selection of the replacement rope and fittings to provide the most cost effective service life. Existing equipment modifications or replacement should be considered in the initial screening of options when considering wire rope replacement. The existing design or the condition of the existing equipment may not allow the service life desired from any replacement rope. For example:

(1) The existing drums and sheaves may be so worn that new rope is quickly abraded.

(2) Sheave or drum diameters may be too small for the rope required for the load, resulting in a quick fatigue failure of the rope.

(3) There can be a significant decrease in rope tension if sheaves with plain bearings are replaced

with roller bearings. This modification could allow the replacement of an improved plow steel rope with a lower strength stainless steel rope, yet the factor of safety could be satisfactory and the rope would have much better corrosion characteristics.

Finally, replacing equipment using wire rope with equipment using chains, gears, or other machinery may be the best option.

4-2. Calculating Rope Load

The following sections include information on sheaves and loads due to bending which must be considered in calculation of rope load for a gate-operating device. A sample problem is included in Appendix J which includes a number of other factors which must also be considered.

4-3. Sheaves

a. Static load. The static load (no movement conditions) for various single- and multiple-sheave block tackles is calculated by dividing the total load by the part-number (number of supporting ropes) of the sheave (Figure 4-2). However, note that rope selection is not based on static load.

b. Dynamic load. The dynamic load (movement conditions lifting) can be significantly greater than static load. Rope selection is based on dynamic load. A portion of a rope's tension is lost as it flexes over sheaves and overcomes the friction in the sheave bearings. The dynamic load factors for various single- and multiple-sheave block tackles are given in Figure 4-3. Compare the static versus dynamic rope tension for a sheave with ten supporting ropes and plain bearings. The static tension is 0.100 of the load. The dynamic tension is 0.156 of the load. In this case, the dynamic rope tension is over 50 percent greater than the static rope tension.

c. Plain versus roller bearings. Dynamic loads for sheaves with roller bearings can be significantly less than for sheaves with plain bearings. For example; compare a 10-part sheave with plain bearings to a 10-part sheave with roller bearings. Their respective rope tensions are 0.156 and 0.123 of the load. The plain bearing sheave system requires its rope to be subjected to 27 percent greater tension. The large difference between plain and roller bearings should be noted. If the plain bearing sheaves for this example were replaced with roller bearing sheaves, a stainless steel rope (with a 10 percent lower strength) could be substituted and have a higher factor of safety than the original rope (Appendix J).

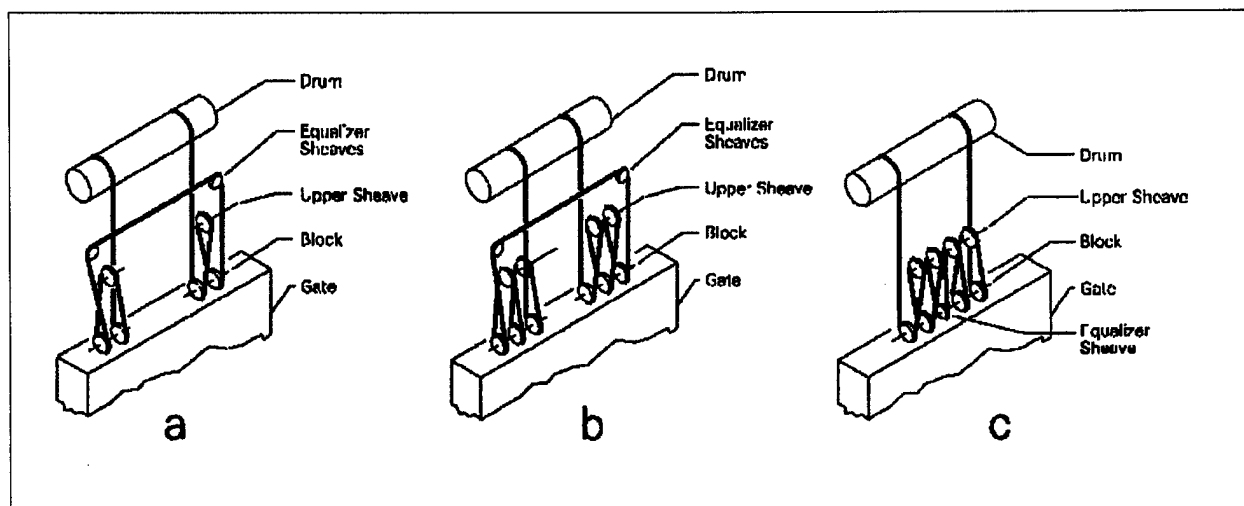

Figure 4-2. Various drum and sheave arrangements: (a) An 8-part sheave, (b) A 12-part sheave, and (c) A 10-part sheave. The part-number is determined by counting the number of supporting ropes

Parts of Line	With Plain Bearing Sleeves	With Roller Bearing Sleeves
1	1.09	1.04
2	.568	.530
3	.395	.360
4	.309	.275
5	.257	.225
6	.223	.191
7	.199	.167
8	.181	.148
9	.167	.135
10	.156	.123
11	.147	.114
12	.140	.106
13	.133	.100
14	.128	.095
15	.124	.090

Figure 4-3. The table presents dynamic rope tension as a portion of load for sheaves with various numbers of supporting ropes. Note that parts-of-line, part-number, and the number of supporting ropes are the same

4-4. Nominal Strength

Nominal strength is the industry accepted breaking strength for a wire rope. Nominal strengths for various wire ropes are given in Appendix C. They should be used when making design calculations. A minimum acceptance strength 2-1/2 percent lower than the published nominal strength has been established as the industry tolerance for testing purposes. This tolerance serves to offset variables that occur during sample preparation and the actual physical test of the wire rope.

4-5. Factor of Safety

a. Dynamic loaded ropes. The factor of safety (FOS) for a dynamic loaded rope on a new Corps gate-operating device should be at least 5, based on nominal strength, the part-number, and the dynamic load. A higher FOS may be justified for an installation where many loading cycles are anticipated and fatigue is a concern. Service life will be longer for a rope with a higher FOS (Figure 4-4). For rope replacement, the same FOS guidelines are recommended. However, the FOS may not be the most important criteria for selection of replacement rope. Current criteria calls for motor stall torque on Corps gate-operating devices to be 0.700 of the nominal strength of the wire rope. However, it may not always be possible to select replacement wire rope which meets the existing criteria. For those devices a strain gauge "trip-out" could be installed to shut down the motor in case of an overload for protection of the rope.

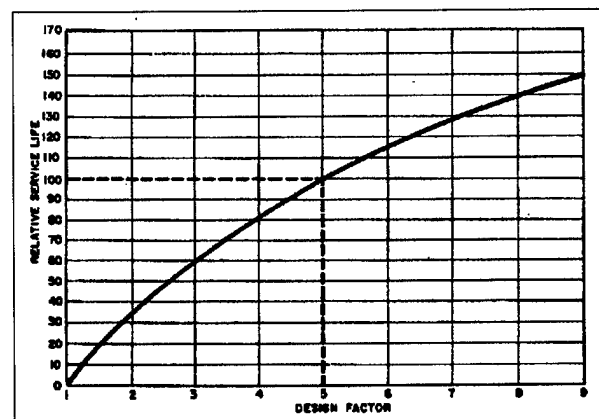

Figure 4-4. Relative service life versus factor of safety

b. Static loads. Some ropes are used for locating or stationing parts of the devices. These ropes should have a FOS of at least 3.0. The FOS in this case would be based on static load and nominal rope strength.

c. Efficiency reductions for sheaves and pins. A rope passing over a curved surface, such as a sheave or a pin, is reduced in strength (or efficiency). The reduction depends on the severity of the bend. Figure 4-5 indicates the efficiency losses for rope bending over sheaves or pins. Efficiency reductions

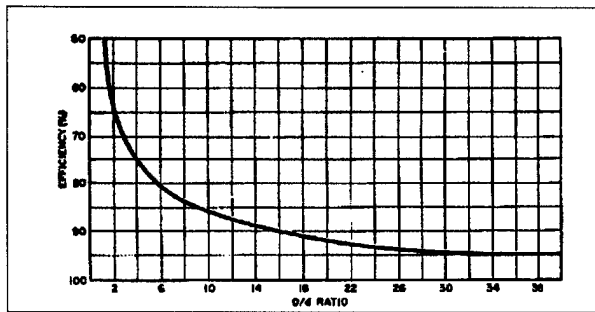

Figure 4-5. The reduction in efficiency of a wire rope bent over a pin or sheave varies with the ratio of the rope diameter (d) compared to the sheave or pin diameter (D)

for sheaves and pins must be considered in determining its FOS.

d. Terminal efficiencies. End terminations must develop the full strength of the rope. Also see Sections 3-1, "Sockets" and 3-3, "Drum and Miscellaneous Terminations" and Appendix D.

e. Reserve strength. The calculated FOS of a new wire rope may be fairly accurate compared to its actual FOS. However, as the rope is used abrasion and fatigue, particularly at the ropes outer wires, reduce its strength. The term reserve strength defines the combined strength of only a wire rope's inner wires that tend to be less affected by abrasion and fatigue (Figure 4-6). Consider a 6x31 classification rope which has 12 outside wires. The inner wires only have a reserve strength of 43 percent. Such a rope with an original FOS of 5 in a severely worn condition would have a much lower FOS since the outer wires have 57 percent of the rope's strength.

4-6. Service Life

As stated earlier, wire rope used in Corps gate-operating devices experiences corrosion, fatigue, and/or abrasion. Excessive stress should not occur. Corrosion, fatigue, and abrasion are distress modes that progress with time and/or use. At an existing installation it may be possible to predict service life for a replacement rope with some accuracy if the service life of an old rope in the same application is known. For a new installation, service can be

Number of Outside Wires	Percent of Reserve Strength
3	0
4	5
5	3
6	8
7	22
8	27
9	32
10	36
12	43
14	49
16	54
18	58

Figure 4-6. Number of outside wires versus reserve strength for 6-, 7-, and 8-strand wire rope

predicted from experience gained on similar existing installations (Section 7-2, "Retirement").

4-7. Rope Length/Stretch

a. General. This section discusses two types of rope elongation, constructional stretch, which occur during the early life of the rope, and elastic stretch which is dependent on the rope's loading. Both are pertinent to determining the length of the rope.

b. Constructional stretch. When a load is applied to a new wire rope, the rope's diameter decreases and its length increases. The amount of this stretch is influenced by a rope's construction and material. FC ropes stretch more than IWRC ropes because a fiber core compresses more than a steel core. (Figure 4-7). Constructional stretch generally ceases at an early stage in the life of a rope. The constructional stretch of individual ropes in multi-rope drums vary. This

Rope Construction	Approximate Stretch*
6 strand FC	.5% to .75%
6 strand IWRC	.25% to .5%
8 strand FC	.75% to 1%

* Varies with the magnitude of the loading

Figure 4-7. Constructional stretch for various rope constructions

may require much tensioning effort to equalize the load. Pre-stretching is a practical and inexpensive way to reduce constructional stretch (Section 2-8, "Manufacturing"). Constructional stretch must be considered when specifying rope length and for design of adjustment mechanisms on operating devices.

c. *Elastic stretch.* It is necessary to know the elastic stretch of a wire rope to specify its length. Elastic stretch is the recoverable deformation of the metal itself. It is dependent on the rope's metal area and the modulus of elasticity of the metal. A reasonable approximation can be made using the equation and information in Figures 4-8 through 4-10. Rather than calculating elastic stretch, wire rope can be measured under tension at the manufacturing facility and socketed for a more accurate length.

$$\Delta L = \frac{\Delta F \times L}{A \times M}$$

Where
 ΔL = Change in Length (ft)
 L = Length (ft)
 ΔF = Change in Load (lbs)
 M = Modulus of Elasticity (psi)

or

$$\Delta L = \frac{G \times \Delta F \times L}{A \times M}$$

Where
 ΔL = Change in Length (m)
 L = Length (m)
 ΔF = Change in Load (kg)
 M = Modulus of Elasticity (MPa)

Figure 4-8. Elastic stretch equation

d. *Adjustable fittings.* Adjustable fittings such as turnbuckles should be considered if tensioning is required. It is important to allow sufficient adjustment length to tighten the rope (as opposed to loosening).

Rope Classification	Area	
	SQ. IN.	SQ. MM
6 x 7 FC	.384	258
6 X 37 FC	.410	276
6 X 19 FC	.427	289
8 X 19 FC	.360	243
6 X 19 IWRC	.475	321
6 X 37 IWRC	.493	333

Figure 4-9. Approximate metal areas of 26 mm (1-in.) wire rope of various constructions

Rope Classification	0% to 20% Loading		21% to 65% Loading	
	PSI	MPa	PSI	MPa
6 x 7 FC	11,700,000	80,670	13,000,000	89,670
6 x 19 FC	10,800,000	74,470	12,000,000	82,740
6 x 37 FC	9,900,000	68,260	11,000,000	75,850
8 x 19 FC	8,100,000	55,850	9,000,000	62,080
6 x 19 IWRC	13,500,000	93,080	15,000,000	103,430
6 x 37 IWRC	12,600,000	86,880	14,000,000	96,530

Figure 4-10. Approximate modulus of elasticity for various wire rope classifications

4-8. Bending Radii

Wire rope operating over sheaves and drums is subjected to cyclic bending stresses. The magnitude of bending stresses are dependent on the ratio of the diameter of the sheave or drum to the diameter of the rope. It is difficult to identify the sheave or drum size most economical for a particular installation. However, it is generally best to not use drums or sheaves smaller than recommended by the manufacturer or smaller than given in Figure 4-11. Figure 4-12 indicates how service life is affected by the bending a rope is subjected to.

4-9. Bearing Pressure

Excessive wear is most often caused by a combination of rope load which is too high, a drum material which is too soft, or drum and sheave tread diameters which

Construction	Suggested Minimum D /d Ratio
6 x 7	42
19 x 7 or 18 x 7 Rotation Resistant	34
6 x 19 S	
6 x 25 B Flattened Strand	
6 x 27 H Flattened Strand	
6 x 30 G Flattened Strand	30
6 x 31 V Flattened Strand	
6 x 21 FW	
6 x 26 WS	
8 x 19 S	
7 x 21 FW	
6 x 25 FW	26
6 x 31 WS	
6 x 37 FWS	
7 x 25 FW	
6 x 36 WS	
6 x 43 FWS	23
7 x 31 WS	
6 x 41 WS	
6 x 41 SFW	
6 x 49 SWS	
7 x 36 WS	20
8 x 25 FW	
19 x 19 Rotation Resistant	
35 x 7 Rotation Resistant	
6 x 46 SFW	
6 x 46 WS	18
8 x 36 WS	

Figure 4-11. Acceptable values for the D/d ratio (where D = sheave or drum diameter and d = rope diameter)

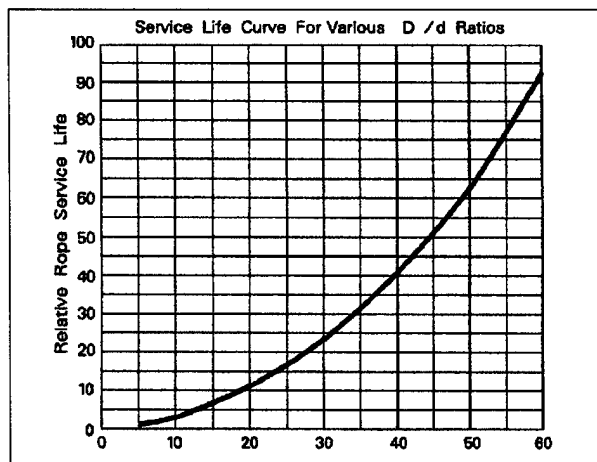

Figure 4-12. Service life of wire rope will vary with bending radii

are too small. Unit radial pressure between the rope and grooves (as calculated in Figure 4-13) represent the first and last factors. Allowable unit radial pressure for drums and sheaves varies with material (Figure 4-14). Note that the materials listed in the table are available in a wide range of hardness, so the pressure values will vary. Note also, that if the allowable radial pressure is exceeded, the drum or sheave's grooves will wear rapidly, eventually causing accelerated wear of the rope.

$$p = 2T / Dd$$

Where

- d = Nominal diameter of rope (in)
- D = Tread dia. of sheaves /drums (in)
- p = Unit radial pressure (psi)
- T = Load on rope (lbs)

or

$$p = 200T (G) / Dd$$

Where

- d = Nominal diameter of rope (mm)
- D = Tread dia. of sheaves /drums (cm)
- p = Unit radial pressure (kPa)
- T = Load on rope (kPa)
- G = Acceleration of gravity 9.807 (m/sec.²)

Figure 4-13. Rope Bearing Pressure

4-10. Fleet Angle

Fleet angle (Figure 4-15) must be within certain limits for smooth winding on drums and to prevent wire rope from crushing and abrading, either on itself or against drum grooves. The limits are 1/2 degree minimum to 1-1/2 degrees maximum for smooth drums and 1/2 degree minimum to 2 degrees maximum for grooved drums.

		Regular Lay Rope			Lang Lay Rope		Flattened Strand Lang Lay
		6 x 19	6 x 37	8 x 19	6 x 19	6 x 37	
Cast Iron 125 Brinell	psi	480	585	680	550	660	800
	kPa	2280	4030	4690	3790	4550	5520
Carbon Steel Casting 160 Brinell	psi	900	1075	1260	1000	1180	1450
	kPa	620	7410	8690	6900	8140	10,000
Manganese Steel, Induction Hardened or Flame Hardened Ground Grooves	psi	2400	3000	3500	2750	3300	4000
	kPa	16,550	20,690	24,130	18,960	22,750	27,580

Figure 4-14. Allowable rope bearing pressure for various sheave/drum materials

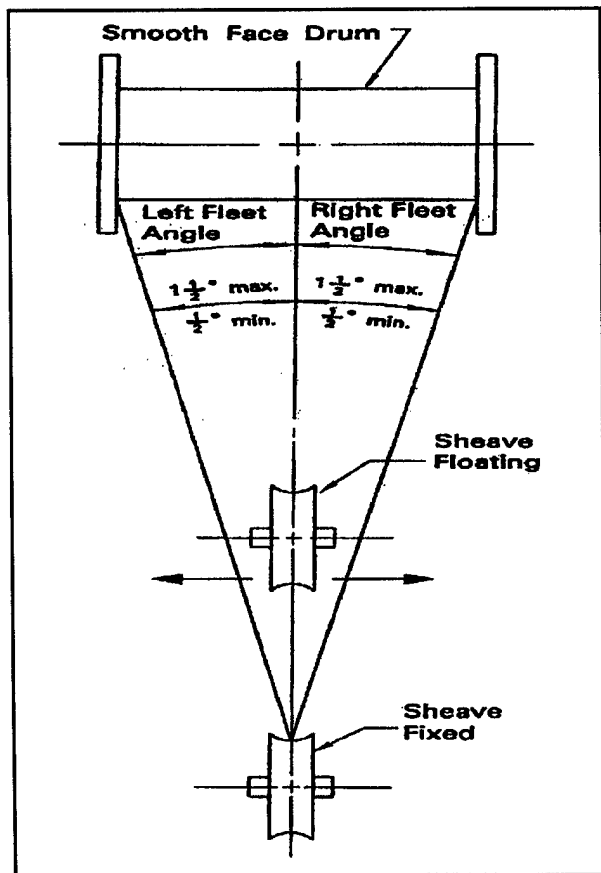

Figure 4-15. This figure illustrates the definition of fleet angle

Chapter 5 Specifying Wire Rope

This chapter presents the standard nomenclature used for ordering wire rope, and information on requirements necessary to specify wire rope for Corps of Engineers gate-operating devices. It also presents information on availability and cost.

5-1. Standard Nomenclature

Standard wire rope specification nomenclature gives the following rope requirements: length, direction and type of lay, diameter, finish, classification, material, preformed or non-preformed, and core type.

For example, a rope manufacturer would consider the following description of a wire rope to be complete:

a. Metric: 152.3 M 38 mm 6x19 Seale pref RLL Galv Improved Plow Steel IWRC.

b. English: 500 ft 1-1/2" 6x19 Seale pref RLL Galv Improved Plow Steel IWRC.

5-2. Additional Requirements

Additional requirements for wire rope that should be considered for inclusion in the specifications:

a. *Wire Strength and Ductility.* Manufacturers occasionally blend stronger and weaker wires in one rope which can have detrimental effects on its fatigue resistance (See Section 2-8 "Manufacturing"). Test procedures for strength and torsion (included in Appendix C) assure that fatigue resistance will not suffer because of this practice.

b. *Rope tension test.* New wire rope should meet the industry accepted nominal strengths. However, it is standard practice to require a rope tension test, to failure, for verification that the expected performance level has been met. The procedure is as follows. The sample length is cut to not less than 0.91 m (3 ft) for rope diameters between 3.2 mm (1/8 in.) and 77 mm (3 in.). The test is only considered valid if failure occurs at least 51 mm (2 in.) from either the socket or

holding mechanism. The relative speed between the testing machine heads (while tensioning) is not allowed to exceed 25 mm (1 in.) per minute.

c. *Verification of preforming.* Preforming should be specified for any steel wire rope for any gate-operating device. The standard test from Federal Specification 410 to verify preforming is as follows. First measure a rope's diameter, then remove the seizing at one end of the rope and again measure its diameter. The difference in diameters may not be more than the values indicated in the table in Appendix C.

d. *Stress relief verification.* The standard wrapping test from Federal Specification 410 verifies that stress relief has been accomplished. It applies to rope with either bare steel or galvanized steel wires. The procedure is as follows. Rope wires are wrapped in a helix about a mandrel for six complete turns, followed by unwrapping. No wires may break or fracture. The mandrel for bare and galvanized steel is two times the diameter of the wire.

e. *Weld distribution.* Welded (or brazed) wire joints should not be any closer than 45.7 cm (18 in.) in any strand.

f. *Zinc coat test.* Appendix C contains recommendations on the amount of zinc required for effective corrosion control for wire rope. It also contains a test procedure from Federal Specification 410 for determining the weight of the zinc coating on wire rope.

g. *Pre-stretching.* As explained in Section 2-8, "Manufacturing," this procedure is recommended for installations with multi-rope drums. The standard procedure and a new dynamic procedure is discussed in that paragraph.

h. *Lubrication.* The designer/specifier must decide if a lubricant will be used with the rope being supplied, and if so, what type of lubricant is needed (Section 7-3, "Lubrication"). If a lubricant will be used, having it applied at the rope manufacturer's facilities is recommended. The manufacturer will generally have equipment which can force the lubricant into the core area of a rope.

i. *Pitch length.* A strand pitch of not less than 4-1/2 times the nominal rope diameter is normally required for the ropes used in gate-operating devices.

j. *Attaching and proof-loading terminations.* As discussed in Section 3-1, "Sockets," it is recommended that swaged and splattered sockets be attached at the rope manufacturer's facilities and also be proof loaded prior to use. Proof loading is normally at 200 percent of the expected load (operating gate) or 40 percent of the nominal strength of the rope. It is practical to perform the proof testing as a part of a pre-stretching operation. Manufacturers should be consulted to decide if existing sockets can be reused.

k. *Core wires (IWRC).* The number of wires in the core strand should be equal to or greater than the number of wires in the other strands. The wires should be of the same material as the wire in the other strands or of a material with a lower tensile strength.

l. *Field acceptance.* The designer/specifier should add several requirements as discussed in Section 6-1, "Field Acceptance," to be certain that the rope purchased will be delivered and installed in good condition.

5-3. Availability/Cost

The cost and availability of the options must be considered in the selection process. For example, sizes larger than 38 mm (1-1/2 in.), some constructions, and most stainless steel rope are not readily available off the shelf. Extra delivery time will likely be required for any special order rope. Availability needs to be discussed with manufacturers early in the selection process. Also, quantities of 3,000 m (10,000 ft) and more are generally required for a standard production run. Runs for smaller quantities will have higher prices per unit length. There is a fixed amount of waste for any run due to normal production methods. Flat and other special shaped rope may not be available at any cost. Figures 5-1 through 5-3 present relative cost data for rope of various materials, types of construction, and sizes.

Rope Material	Relative Cost
Iron or Extra Strength Traction Steel	0.40 - 0.50
Improved Plow Steel	0.96 - 0.98
Extra Improved Plow Steel	1.00
Galvanized Improved Plow Steel	1.25 - 1.35
Stainless	2.5 - 3.10

Figure 5-1. Relative cost data (per unit length) for wire rope of various materials

Rope Construction	Relative Cost
6 x 19 Class FC	
6 x 19 FC	0.93
6 x 21 FC	
6 x 25 FC	
6 x 26 FC	
6 x 19 Class IWRC	
6 x 19	1.00
6 x 21	
6 x 25	
6 x 26	
6 x 37 Class FC	
6 x 31 FC	1.08
6 x 36 FC	
6 x 41 FC	
6 x 49 FC	
6 x 37 Class IWRC	
6 x 31 IWRC	1.15
6 x 36 IWRC	
6 x 37 IWRC	
6 x 41 IWRC	
Flattened Strand FC or IWRC	
6 x 25 Type B	1.65
6 x 30 Type G	

Figure 5-2. Relative cost data (per unit length) for wire rope of various constructions

Nominal Rope Size		
in.	mm	Relative Cost
1/2	13	.38
5/8	16	.47
3/4	19	.64
7/8	22	.82
1	26	1.00
1 1/8	29	1.20
1 1/4	32	1.43
1 3/8	35	1.72
1 1/2	38	2.06
1 5/8	42	2.47
1 3/4	45	2.92
1 7/8	48	3.33
2	51	3.78
2 1/8	54	4.34
2 1/4	57	4.97
2 3/8	60	5.43
2 1/2	64	5.88

Figure 5-3. Relative cost data (per unit length) for wire rope of various sizes

5-4 Buy American

The best wire rope has traditionally been and still is manufactured in the U.S. Note that all domestic made rope is color coded within the strands with the specific manufacturer's colors for easy identification. However, the number of major U.S. wire rope manufacturers has decreased from more than one dozen in 1975 to 5 in 1996. A high portion of the wire rope of foreign manufacture has given unsatisfactory service. Although some of the western European countries have manufacturers which produce good rope, buying foreign made rope is risky. It is highly recommended that wire rope for Corps gate-operating devices be required to have been manufactured in the U.S. The contract specifications for this requirement should conform to Part 25 of the Federal Acquisition Regulations.

Chapter 6 Field Acceptance and Installation

6-1. Field Acceptance

a. Measurement of diameter. The diameter of a wire rope must be measured prior to installation to verify it is as specified and correct for its device, and also to verify it is within the industry tolerance. The industry tolerances per the Wire Rope Technical Board, for wire ropes over 8.0 mm (5/16 in.) are -0 and +5 percent of nominal diameter. Note that new ropes are usually larger than their published diameters, and as stated above, should never be smaller. Diameter shall be measured with the rope loaded between 10 and 20 percent of nominal strength. Figure 6-1 indicates the proper method of measuring diameter.

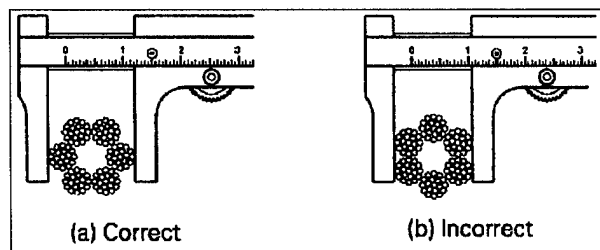

Figure 6-1. The diameter of a wire rope is defined as the diameter of its circumscribing circle. Six-strand wire rope should be measured across each of the three opposite strands and eight strand wire rope should be measured across each of the four opposite strands. Special techniques must be used for measuring ropes with an odd number of outer strands

b. Damage inspection. Upon receiving the wire rope, it is important to inspect for damaged packaging, dings, and kinks. The inspection should be scheduled with the supplier present. A report of the results should be made upon completion of the inspection.

6-2. Storage, Handling, and Unreeling

a. Long-term storage. If wire rope must be stored for long periods, it should be in a well-ventilated, weatherproof building or storage shed. If stored on

wooden spools in humid areas with low light and poor air circulation, damage from microbiologically influenced corrosion may occur. Wire rope should never be stored outdoors.

b. Handling/unreeling. Wire rope is wound on reels for shipping at the manufacturer's facility in the same direction as it bends during manufacturing. This bending direction is an inherent feature of the rope. It must be unreeled from its shipping reel and be installed onto its equipment, only bending in this same direction. Reverse bending may cause the rope to become "twisty." It is best to keep wire rope under tension when handling to avoid it becoming looped. Pulling on a loop may result in kinks, permanently damaging the rope. The Wire Rope Users Manual recommends a number of techniques for wire rope handling to avoid reverse bending and kinking.

6-3. Installation

The following paragraphs present guidance on wire rope installation. Requirements for installation should be presented in the specifications. It is also recommended that the specifications require an installation plan as a submittal.

a. Field tensioning of multi-line hoists. It is important to achieve equal tensioning in a gate-operating device which uses several ropes in parallel. The rope(s) having the higher tension will carry more load and are likely to wear and/or fatigue more rapidly than the others. When ropes are replaced, it is recommended that all ropes be replaced. Replacement of one or some of the ropes is not generally practical for two reasons. First, keeping the old and new ropes in equal tension would be a difficult. The new ropes tend to stretch more quickly than the old ropes, causing the old ropes to carry a greater share of the total load. Frequent tensioning would be required to alleviate this problem. Second, when ropes are replaced piecemeal, installation costs would be greater over the life of the project. Appendix E includes information on the rope tensioning devices.

b. Drum attachment. Grooved, plain, and layered drums each require the adherence to certain rules when attaching/installing wire rope.

30 Sep 98

(1) Grooved drums. The rope must be wound under adequate and continuous tension, and must follow the groove, or it will be cut and crushed where it crosses. Two dead wraps are mandatory, and three are preferable.

(2) Plain drums. The rope must be wound under adequate and continuous tension, and each wrap must be guided as close to the preceding wrap as possible, so there are no gaps between turns. Two dead wraps are mandatory, and three are preferable.

(3) Layered drums. The rope must be wound under adequate and continuous tension. Two dead wraps are mandatory, and three are preferable.

c. Dynamometer tests. A dynamometer test monitors wire rope tension during operation of its

gate-operating device. The test link is normally mechanical. This test verifies that the rope is not subjected to higher tension than intended. Information on dynamometer test links is included in Appendix E.

d. Break-in procedure. In addition to following the above procedures, it is best if wire rope is "broken in." Ideally, a light load and a slow speed would be used while the operating device is cycled through a few operations. However, in most gate-operating devices, both the load and speed are fixed. The device should be cycled a few times while a number of personnel are stationed in positions to verify that the rope runs freely through all drums, sheaves, and guides.

Chapter 7 Inspection, Maintenance, Retirement, Etc.

7-1. Inspection

a. Frequency of inspection. The frequency of inspection required for wire rope at Corps facilities varies considerably, depending on usage, the environment the rope is subjected to, and the lubrication program. The inspection program should be formulated during the formulation of a project's O&M manuals. At some Corps facilities the gates are rarely operated, and the ropes are of stainless steel, making annual inspections adequate. At other facilities, gates are operated many times per day, and monthly inspections may be appropriate.

b. Rope indicators.

(1) Diameter reduction. The diameter of wire rope reduces as it degrades from abrasion, corrosion, inner wire breakage, stretch, etc. A rope's diameter should be measured when new and periodically throughout its life (at the same loading and in the same areas). A one-time comparison between a rope's measured diameter and its nominal diameter is not a true indicator of its condition. Measured diameters must be recorded and kept for historical reference. This procedure will typically show a rapid initial reduction in the rope's diameter followed by a slower more linear reduction. A sudden diameter decrease marks core deterioration and indicates a need for replacement.

(2) Stretch. Before rope installation is performed, a method should be devised to periodically measure rope stretch (at the same loading). Rope stretch typically occurs in three distinct stages (Figure 7-1). The first stage is constructional stretch as discussed in Section 4-7, "Rope Length/Stretch." It is rapid and of a short duration and can be reduced by pre-stretching. In the second stage, a small amount of stretch takes place over an extended time. This results from normal wear, fatigue, etc. The third stage is marked by an accelerating rate of stretch. This signals rapid degradation of the rope from prolonged wear, fatigue, etc. Replacement is required when the rope enters this stage.

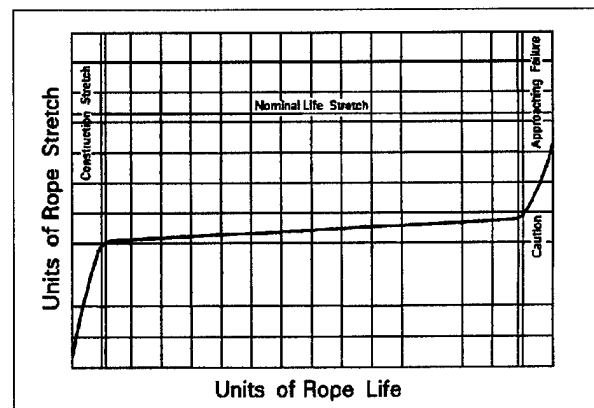

Figure 7-1. Rope life versus stretch

(3) Abrasion. Most standards require rope replacement when the outer wire wear exceeds 1/3 of original wire diameter. Since wear occurs mostly on the outer wires' outer surfaces, measuring or determining the exact amount of wear is difficult. Dismantling and measuring wire diameters of discarded ropes can provide training for the inspector.

(4) Broken wires. The number of broken wires on the outside of a wire rope provides an index of its general condition. Wire rope on gate-operating devices should be replaced if the number of broken wires per lay length reaches 6, or if the number of broken wires per strand rotation length reaches 3. If more than one wire fails adjacent to a termination, the rope shall be replaced immediately. It is common for a single wire to break shortly after installation, which may not be a concern. However, if more wires break, the situation should be investigated. Once breaks begin to appear, many more will generally occur within a relatively short time. Attempts to get the last measure of service from a rope can create a dangerous situation. Broken wires in the valleys of rope (between the strands) indicate a very serious condition. When two or more such fractures are found, the rope should be replaced immediately. A determination of the cause of wire breaks should be made before replacing the rope. Figure 7-2 shows various types of breaks.

(5) Corrosion. Corrosion may be the most common and serious form of rope degradation on gate-lifting devices. There is no known method of calculating the strength of a corroded rope. It will

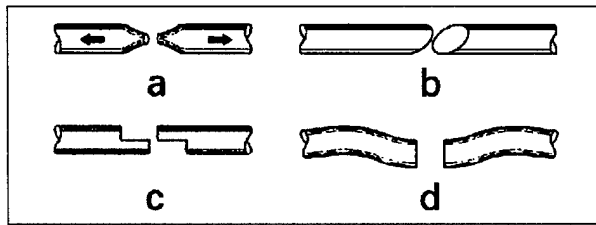

Figure 7-2. Various types of wire breaks: (a) a ductile failure from too great a load, (b) a shear-tensile failure from a combination of transverse and axial loads, (c) and (d) breaks from fatigue

often occur internally before any evidence appears on the external surface. A slight discoloration from rust is usually just an indication that lubrication is overdue. However, severe rusting leads to fatigue failure, especially in areas that normally would not fail, such as near terminations, where bending is not required. Pitting is the worst form of corrosion. If pitting is observed, the rope should be replaced. Not only do the pits damage the wires on which they occur, they also prevent the rope's component parts from moving freely when moving over sheaves and drums. This contributes to abrasion and fatigue.

(6) Peening. Continuous pounding is one cause of peening. It can occur when a rope vibrates against another component, or if a rope is continuously

worked against a drum or a sheave at a high pressure. The appearances of peening and abrasion are compared in Figure 7-3. Heavy peening can result in wires cracking and breaking and may eventually require rope replacement.

(7) Scrubbing. Scrubbing occurs when a rope rubs against itself or another object. Its effects are normally evident on only one side of a rope. If corrective measures are not taken in time, rope replacement may be required.

(8) Localized conditions. It is typical for gate-operating devices at some Corps installations to position their rope at one or two locations most of the time. This concentrates wear or damage at these areas. Also, special attention should be given to rope in the areas of equalizing sheaves. Only slight movement occurs over them, usually a rocking motion. This causes a concentration of bending and abrasion where the rope meets the sheave groove. Look for worn and broken wires. Note that this is an area where deterioration may not be readily detected. Careful checking and operating of the device may be required to make rope damage more visible. End fittings are especially susceptible to damage if they are submerged. This would require the gate to be lifted for the inspection.

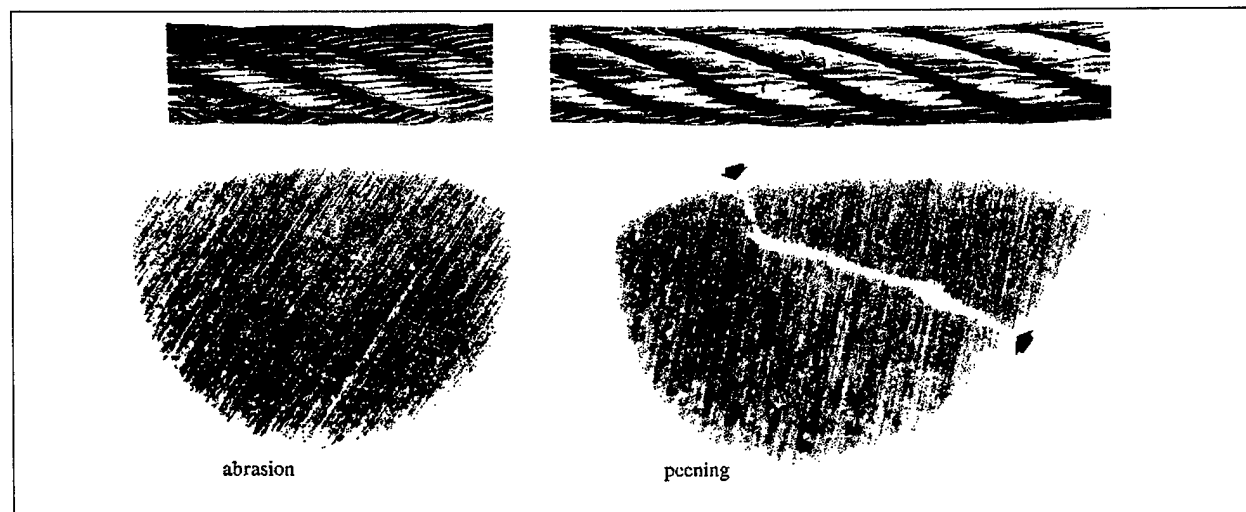

Figure 7-3. A comparison of abrasion and peening: Abrasion wears away wire material. Peening swages and fatigues. Notice the crack between the arrows

(9) Other forms. There are several other forms of rope damage, all of which call for immediate rope replacement. They include kinks, bird caging, protruding cores, and heat damage. Kinking is discussed in Section 6-2, "Storage, Handling, and Unreeling." Bird caging is a separation of the strands or wires resulting from shock or sudden loading. Any time a rope's core is visible, the rope must be replaced. Heat damage is usually evident as a discoloration of the rope wires, and also calls for rope replacement.

(10) Over-stressing. There have been occasions when a gate-operating device jams, or one or more ropes on a multi-rope device breaks. On these occasions a rope (or ropes) have been overstressed compared to their design load. Determining if the rope was damaged may be impossible. In some instances damage may be indicated by a change in lay length. If so, the area of change may be small, so finding this evidence may be difficult. If a wire rope has been damaged because of overstressing it should be replaced. If damage is suspected, but not proven, it is better to err on the conservative side. As a minimum, the potential of overstressing must be considered at the end of the rope's projected service life (See Section 7-2, "Retirement").

c. Indicators for sheaves, etc. Inspection of sheaves, pulleys, drums, fittings, and any other machine parts or components coming into contact with the rope is also required. The inspection of these components should be performed at the same time as the wire rope inspection and the results should likewise be documented.

(1) Sheaves, pulleys, and drums. The first item to be checked when inspecting sheaves, pulleys, roller guides, and (grooved) drums is groove size. This is done with "go" and "no-go" gauges as shown in Figure 7-4. Second, the condition of the grooves must be inspected. The pattern of the rope may be imprinted in the groove. If so, rope wear will be greatly increased. Third, the inspector should check for wobble in the bearings, broken flanges, flat spots, or off center groove wear.

(2) Fittings. Cracked, bent, worn, or broken fittings must be replaced. Look for broken wires and loose or damaged strands adjacent to fittings. If more

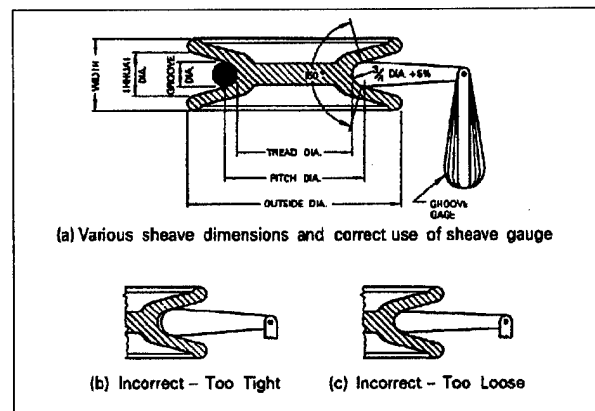

Figure 7-4. Measuring groove diameter with a Go/No-Go gauge

than one wire has failed adjacent to a termination, the rope should be replaced immediately.

d. Inspection reports. In addition to planning and carrying out an inspection program, it is necessary to store and analyze the data. A sample inspection report form is included in Appendix G. It is recommended that inspection reports be signed and dated. They should be kept for the life of the rope and after its replacement. The report data should be compared with data from previous reports to identify any trends that may occur.

7-2. Retirement

a. Service life. Section 7-1 discusses wire rope inspection, and gives some criteria for retirement. However, it is recommended that wire rope used on gate-operating devices be assumed to have a maximum service life of 20 years. Devices with previous records of short rope life should be assumed to have a shorter rope service life.

b. Failure analysis. A failure analysis should be performed on any retired rope to determine its prime failure mode(s) so a replacement rope can be selected with a cost effective service life.

c. Disposal of wire rope. The disposal of failed or retired wire rope may pose a problem. Wire rope is not easily processed by the shredders used to prepare scrap metal for re-melting. Lubricated wire rope cannot be buried in landfills in some states. Also, sizes

13 mm (1/2-in.) through 22 mm (7/8-in.) used wire rope is suitable for drag line use. However, most wire rope used for gate-operating devices is larger and is not in demand in a used condition. If replacement rope will be installed by contract, having the contractor "remove and dispose of properly" may be the best option.

7-3. Lubrication

a. Rope lubrication. There are two reasons for lubricating wire rope, wear reduction and corrosion reduction. Ropes are usually lubricated by the manufacturer during fabrication. The manufacturer will generally have shop equipment which can force lubricant into the core area of the rope. The initial treatment is generally adequate for transport and storage, and it will usually protect the rope for a short time after initial use. However, it will usually not provide the lubrication needed for the rope's full life. Periodic cleaning and lubrication are usually necessary. A rope can be cleaned with a stiff wire brush dipped in solvent, with compressed air, or with superheated steam. The object of cleaning is to remove any foreign material and old lubricant from the valleys between the strands and from the spaces between the outer wires. New lubricant is applied by continuous bath, dripping, pouring, swabbing, painting, or by spray nozzle. In selecting the type of lubricant, a number of issues need to be considered such as:

- (1) Clear lubricant may be required for exterior rope inspection.
- (2) Hot weather conditions may liquefy normal lubricant.
- (3) High frequency or unusual amount of lubricant may emphasize cost.
- (4) Special environmental requirements may limit lubricant selection.

Specific brand names and types of lubricants are listed and discussed in Appendix H. Also, not lubricating may be considered in situations where the rope is stainless steel and operation is infrequent. Lubrication can seal moisture in the voids between the rope wires

and on their outer surfaces causing corrosion. Tests have indicated that corrosion will be less severe for a non-lubricated rope than for one which is infrequently lubricated. Infrequent lubrication causes areas on a rope's surface to have no lubricant for extended periods of time. In humid atmospheres, or submerged conditions, this produces corrosion cells which cause deep pitting. If a rope is not lubricated, corrosion tends to be shallow and over a large area. The deep pits on the infrequently lubricated rope are much more damaging than losing a thin layer of metal over a large area. Also, if a rope is frequently lubricated, the corrosion cells may still form, but their duration will be shorter, and their locations change each time the rope is lubricated. Consequently, a greater number of pits may occur, but they tend to be shallow. Again, the deep pits on the infrequently lubricated rope are much more damaging. For additional information on wire rope lubrication, refer to the upcoming Engineer Manual on lubrication.

b. Sheave lubrication. Sheave bearings should be lubricated periodically. Increased friction at wire rope sheaves can significantly affect the tension required to lift a given load (Section 4-2, "Calculating Rope Load"). Lubrication points for sheaves should be in accessible locations. If this is not true for existing equipment, modifications should be considered.

7-4. Ice and Debris Removal

The presence of ice or debris in or on gates or gate-operating devices produces conditions of excessive stress, which may cause failure of ropes and other equipment. Ice may make gates impossible to move. Debris trapped in multi-line hoists can cause unequal tension in the ropes. Safety devices which limit rope tension can reduce the probability of such failures (Appendix E). Ice can be removed by spraying with cold or heated water, or to some extent, it can be prevented from forming with heated panels (Appendix I).

7-5. Painting

When painting is performed around wire ropes, special care should be taken to make sure that they are protected from overspray. Some paint contains

chlorides (and other chemicals) which may contribute to or cause corrosion of the rope.

7-6. Cathodic Protection

Cathodic protection is often used for gates but is less often used for wire rope. Cathodic protection of

submerged wire rope is possible, while protection of wire rope in damp environments is not. The sacrificial anode method, using magnesium anodes, is recommended over the impressed current method. The anodes must be grounded to the rope socket and located close to the rope sockets (see Sections 3-2, "Materials/Coatings" and 3-5, "Two-Piece Ropes").

Appendix A References

A-1. Required Publications

NOTE - The authors of this manual would like to express appreciation to the Wire Rope Technical Board. Many of the facts, figures, and tables presented in this manual were reproduced with permission from the Wire Rope Users Manual.

FAR Part 25
Foreign Acquisition

ASTM E 1571
Standard Practice for Electromagnetic Examination of Ferromagnetic Steel Wire Rope

Wire Rope Technical Board
Wire Rope Technical Board. 1993. *Wire Rope Users Manual*, third edition, Woodstock, MD.

A-2. Related Publications

EM 1110-2-2703
Gate Locks and Operating Equipment

EM 1110-2-4205
Hydroelectric Power Plants, Mechanical Design

CWGS 14330
Indoor Traveling Bridge Crane

CWGS-14340
Dam Gantry Cranes

NAVSEA S9086-BK-STM-000/CH 613
Wire and Fiber Rope and Rigging

Federal Specification RR-W-410D
Wire Rope and Strand

Broderick and Bascom Rope Company 1966
Broderick and Bascom Rope Company. 1966. *Wire Rope Handbook*, Sedalia, MO.

Crane Manufacturers Association of America 1944
Crane Manufacturers Association of America. 1994. *Top Running Bridge and Gantry Cranes*, CMAA Specification 70, Charlotte, NC.

National Association of Corrosion Engineers 1984
National Association of Corrosion Engineers. 1984. *Corrosion Basics: An Introduction*, Houston, TX.

Appendix B Glossary

Brangle - A strand that is shaped after fabrication (for example, triangular).

Classification - Rope's construction as seen in cross section.

Dynamometer test - A test measuring rope tension, usually during break-in.

EIPS - Extra improved plow steel.

FC - fiber core.

Fleet angle - The angle a rope forms with a line perpendicular to its drum.

High-stranding - A failure where one strand of a rope loosens and sticks out from the other strands of a rope.

IPS - Improved plow steel.

IWRC - Independent wire rope core.

Lay - A designation of the way wire strands are laid around the a rope.

Nominal strength - The industry accepted strength of a rope of a certain size, material, and construction.

Part-number - The number of load bearing ropes for a sheave.

Pin - A rope guide of small diameter.

Plow steel - A grade of steel above traction steel, referring to its original use of pulling plows.

Preforming - Forming an individual wire of a rope into a helix.

Pre-stretching - Factory stretching a rope to reduce the constructional amount of stretch.

PS - Plow steel.

Reserve strength - The remaining strength of a rope if all its outer wires were removed.

Seizing - Tying or binding a rope in preparation for cutting it.

Speltered socket - Either a zinc- or epoxy-filled socket.

Strand - The bundles of wires laid helically around a rope's core.

Tensioning - Adjusting the tensions of the individual ropes on a multi-rope device.

Terminal efficiency - Strength of a rope terminal compared to that of the rope.

Traction steel - A low grade of steel.

TS - Traction steel.

Appendix C Nominal Strengths and Testing

C-1. Nominal Strengths of Wire Rope

The following tables (C1 through C12) show the nominal strengths of different types of wire rope.

**Table C1
6 x 9 Classification/Bright (Uncoated), FC**

Nominal Diameter		Approximate Mass		Nominal Strength, Improved Plow Steel	
in.	mm	lb/ft	kg/m	Tons	Metric tons
5/8	16	0.66	0.98	16.7	15.1
3/4	19	0.95	1.41	23.8	21.6
7/8	22	1.29	1.92	32.2	29.2
1	26	1.68	2.5	41.8	37.9
1-1/8	29	2.13	3.17	52.6	47.7
1-1/4	32	2.63	3.91	64.6	58.6
1-3/8	35	3.18	4.73	77.7	70.5
1-1/2	38	3.78	5.63	92.0	83.5
1-5/8	42	4.44	6.61	107	97.1
1-3/4	45	5.15	7.66	124	112
1-7/8	48	5.91	8.8	141	128
2	52	6.72	10.0	160	145
2-1/8	54	7.59	11.3	179	162
2-1/4	57	8.51	12.7	200	181
2-3/8	60	9.48	14.1	222	201
2-1/2	64	10.5	15.6	244	221

Table C2
6 x 19 Classification/Bright (Uncoated), IWRC

Nominal Diameter		Approximate Mass		Nominal Strength, Plow Steel			
				Improved		Extra Improved	
in.	mm	lb/ft	kg/m	Tons	Metric Tons	Tons	Metric Tons
5/8	16	0.72	1.07	17.7	16.2	20.6	18.7
3/4	19	1.04	1.55	25.6	23.2	29.4	26.7
7/8	22	1.42	2.11	34.6	31.4	39.8	36.1
1	26	1.85	2.75	44.9	40.7	51.7	46.9
1-1/8	29	2.34	3.48	56.5	51.3	65.0	59.0
1-1/4	32	2.89	4.30	69.4	63.0	79.9	72.5
1-3/8	35	3.5	5.21	83.5	75.7	96.0	87.1
1-1/2	38	4.16	6.19	98.9	89.7	114	103
1-5/8	42	4.88	7.26	115	104	132	120
1-3/4	45	5.67	8.44	133	121	153	139
1-7/8	48	6.5	9.67	152	138	174	158
2	52	7.39	11.0	172	156	198	180
2-1/8	54	8.35	12.4	192	174	221	200
2-1/4	57	9.36	13.9	215	195	247	224
2-3/8	60	10.4	15.5	239	217	274	249
2-1/2	64	11.6	17.3	262	238	302	274

Table C3
6 x 37 Classification/Bright (Uncoated), FC

Nominal Diameter		Approximate Mass		Nominal Strength, Improved Plow Steel	
in.	mm	lb/ft	kg/m	Tons	Metric tons
5/8	16	0.66	0.98	16.7	15.1
3/4	19	0.95	1.41	23.8	21.6
7/8	22	1.29	1.92	32.2	29.2
1	26	1.68	2.5	41.8	37.9
1-1/8	29	2.13	3.17	52.6	47.7
1-1/4	32	2.63	3.91	64.6	58.6
1-3/8	35	3.18	4.73	77.7	70.5
1-1/2	38	3.78	5.63	92.0	83.5
1-5/8	42	4.44	6.61	107	97.1
1-3/4	45	5.15	7.66	124	112
1-7/8	48	5.91	8.8	141	128
2	52	6.72	10.0	160	145
2-1/8	54	7.59	11.3	179	162
2-1/4	57	8.51	12.7	200	181
2-3/8	60	9.48	14.1	222	201
2-1/2	64	10.5	15.6	244	221

Table C4
6 x 37 Classification/Bright (Uncoated), IWRC

Nominal Diameter		Approximate Mass		Nominal Strength, Plow Steel			
				Improved		Extra Improved	
in.	mm	lb/ft	kg/m	Tons	Metric Tons	Tons	Metric Tons
5/8	16	0.72	1.07	17.7	16.2	20.6	18.7
3/4	19	1.04	1.55	25.6	23.2	29.4	26.7
7/8	22	1.42	2.11	34.6	31.4	39.8	36.1
1	26	1.85	2.75	44.9	40.7	51.7	46.9
1-1/8	29	2.34	3.48	56.5	51.3	65.0	59.0
1-1/4	32	2.89	4.30	69.4	63.0	79.9	72.5
1-3/8	35	3.5	5.21	83.5	75.7	96.0	87.1
1-1/2	38	4.16	6.19	98.9	89.7	114	103
1-5/8	42	4.88	7.26	115	104	132	120
1-3/4	45	5.67	8.44	133	121	153	139
1-7/8	48	6.5	9.67	152	138	174	158
2	52	7.39	11.0	172	156	198	180
2-1/8	54	8.35	12.4	192	174	221	200
2-1/4	57	9.36	13.9	215	195	247	224
2-3/8	60	10.4	15.5	239	217	274	249
2-1/2	64	11.6	17.3	262	238	302	274

Table C5
6 x 61 Classification/Bright (Uncoated), FC

Nominal Diameter		Approximate Mass		Nominal Strength, Improved Plow Steel	
in.	mm	lb/ft	kg/m	Tons	Metric tons
1	26	1.68	2.50	39.8	36.1
1-1/8	29	2.13	3.17	50.1	45.4
1-1/4	32	2.63	3.91	61.5	55.8
1-3/8	35	3.18	4.73	74.1	67.2
1-1/2	38	3.78	5.63	87.9	79.7
1-5/8	42	4.44	6.61	103	93.4
1-3/4	45	5.15	7.66	119	108
1-7/8	48	5.91	8.80	136	123
2	52	6.77	10.1	154	140
2-1/8	54	7.59	11.3	173	157
2-1/4	57	8.51	12.7	193	175
2-3/8	60	9.48	14.1	214	194

Table C6
6 x 61 Classification/Bright (Uncoated), IWRC

Nominal Diameter		Approximate Mass		Nominal Strength, Plow Steel			
				Improved		Extra Improved	
in.	mm	lb/ft	kg/m	Tons	Metric Tons	Tons	Metric Tons
1	26	1.85	2.75	42.8	38.8	49.1	44.5
1-1/8	29	2.34	3.48	53.9	48.9	61.9	56.2
1-1/4	32	2.89	4.30	66.1	60.0	76.1	69.0
1-3/8	35	3.50	5.21	79.7	72.3	91.7	83.2
1-1/2	38	4.16	6.19	94.5	85.7	109	98.9
1-5/8	42	4.88	7.26	111	101	127	115
1-3/4	45	5.67	8.44	128	116	146	132
1-7/8	48	6.50	9.67	146	132	168	152
2	52	7.39	11.0	165	150	190	172
2-1/8	54	8.35	12.4	186	169	214	194
2-1/4	57	9.36	13.9	207	188	239	217
2-3/8	60	10.40	15.5	230	209	264	240

Table C7
6 x 25 B, 6 x 27 H, 6 x 30 G Flattened Strand/Bright (Uncoated), FC

Nominal Diameter		Approximate Mass		Nominal Strength, Improved Plow Steel	
in.	mm	lb/ft	kg/m	Tons	Metric tons
5/8	16	0.70	1.04	18.3	16.6
3/4	19	1.01	1.50	26.2	23.8
7/8	22	1.39	2.07	35.4	32.1
1	26	1.80	2.68	46.0	41.7
1-1/8	29	2.28	3.39	57.9	52.5
1-1/4	32	2.81	4.18	71.0	64.4
1-3/8	35	3.40	5.06	85.5	77.6
1-1/2	38	4.05	6.03	101	91.6
1-5/8	42	4.75	7.07	118	107
1-3/4	45	5.51	8.20	138	123
1-7/8	48	6.33	9.42	155	141
2	52	7.20	10.70	176	160

Table C8
6 x 25 B, 6 x 27 H & 30 G Flattened Strand/Bright (Uncoated), IWRC

Nominal Diameter		Approximate Mass		Nominal Strength, Plow Steel			
				Improved		Extra Improved	
in.	mm	lb/ft	kg/m	Tons	Metric Tons	Tons	Metric Tons
5/8	16	0.73	1.09	19.6	17.8	21.7	19.7
3/4	19	1.06	1.58	28.1	25.5	31	28.1
7/8	22	1.46	2.17	38.0	34.5	41.9	38
1	26	1.89	2.83	49.4	44.8	54.4	49.4
1-1/8	29	2.39	3.56	62.2	56.4	68.5	62.1
1-1/4	32	2.95	4.39	76.3	69.2	84	76.2
1-3/8	35	3.57	5.31	91.9	83.4	101	91.6
1-1/2	38	4.25	6.32	108	98	119	108
1-5/8	42	4.98	7.41	127	115	140	127
1-3/4	45	5.78	8.60	146	132	161	146
1-7/8	48	6.65	9.90	167	152	184	167
2	52	7.56	11.3	189	171	207	188

Table C9
8 x 19 Classification/Bright (Uncoated), FC

Nominal Diameter		Approximate Mass		Nominal Strength, Improved Plow Steel	
in.	mm	lb/ft	kg/m	Tons	Metric tons
5/8	16	0.61	0.91	14.3	13.0
3/4	19	0.88	1.31	20.5	18.6
7/8	22	1.20	1.79	27.7	25.1
1	26	1.57	2.34	36.0	32.7
1-1/8	29	1.99	2.96	45.3	41.1
1-1/4	32	2.45	3.65	55.7	50.5
1-3/8	35	2.97	4.42	67.1	60.7
1-1/2	38	3.53	5.25	79.4	72.0

Table C10
6 x 19 and 6 x 37 Classification/Bright (Uncoated), IWRC

Nominal Diameter		Approximate Mass		Nominal Strength, Plow Steel	
				Improved	
in.	mm	lb/ft	kg/m	Tons	Metric Tons
5/8	16	0.72	1.07	22.7	20.6
3/4	19	1.04	1.55	32.4	29.4
7/8	22	1.42	2.11	43.8	39.7
1	26	1.85	2.75	56.9	51.6
1-1/8	29	2.34	3.48	71.5	64.9
1-1/4	32	2.89	4.30	87.9	79.8
1-3/8	35	3.5	5.21	106	95.8
1-1/2	38	4.16	6.19	125	113
1-5/8	42	4.88	7.26	146	132
1-3/4	45	5.67	8.44	169	153
1-7/8	48	6.5	9.67	192	174
2	52	7.39	11.0	217	198
2-1/8	54	8.35	12.4	243	220
2-1/4	57	9.36	13.9	272	246
2-3/8	60	10.4	15.5	301	274
2-1/2	64	11.6	17.3	332	301

Table C11
Compacted Strand Wire Rope, 6 x 19 and 6 x 37 Classification/Bright (Uncoated), FC & IWRC

Nominal Diameter		Approximate Mass				Nominal Strength			
		lb/ft		kg/m		Tons		Metric Tons	
in.	mm	FC	IWRC	FC	IWRC	FC	IWRC	FC	IWRC
5/8	16	.71	.78	1.06	1.16	20.2	22.7	18.3	20.6
3/4	19	1.03	1.13	1.53	1.68	28.8	32.4	26.1	29.4
7/8	22	1.40	1.54	2.08	2.29	39.0	43.8	35.4	39.7
1	26	1.82	2.00	2.71	2.98	50.7	56.9	46.0	51.6
1-1/8	29	2.31	2.54	3.44	3.78	63.6	71.5	57.7	64.9
1-1/4	32	2.85	3.14	4.24	4.67	78.2	87.9	70.9	79.7
1-3/8	35	3.45	3.80	5.13	5.65	94.1	106	85.4	96.1
1-1/2	38	4.10	4.50	6.10	6.70	111	125	101	113
1-5/8	42	4.80	5.27	7.14	7.84	130	146	118	132
1-3/4	45	5.56	6.12	8.27	9.11	150	169	136	153
1-7/8	48	6.38	7.02	9.49	10.4	171	192	155	174
2	51	7.26	7.98	10.8	11.9	193	217	175	197

Table C12
Compacted (Swaged) Wire Rope, 6 x 19 and 6 x 37 Classification/Bright (Uncoated), IWRC

Nominal Diameter		Approximate Mass		Nominal Strength	
				Extra Improved Plow Steel	
in.	mm	lb/ft	kg/m	Tons	Metric Tons
5/8	16	0.87	1.29	24.2	22.0
3/4	19	1.25	1.86	34.9	31.7
7/8	22	1.70	2.53	47.4	43.0
1	26	2.22	3.30	62.0	56.3
1-1/8	29	2.80	4.16	73.5	66.7
1-1/4	32	3.40	5.05	90.0	81.8
1-3/8	35	4.20	6.24	106.0	96.2
1-1/2	38	5.00	7.43	130.0	118.0

C-2. General Testing Information

Note that zinc, tensile, torsion, and preforming requirements should be considered for inclusion in the specifications for wire rope for lifting devices for Corps applications. The tests in this appendix can be used to verify those requirements.

C-3. Zinc-Coating Test

a. General. The zinc coating shall be tested for weight by the hydrochloric (muriatic) acid-antimony chloride method, also called the stripping method. The specimens shall be cleaned with an organic solvent, rinsed in water, and dried. The surface shall be considered to be sufficiently clean when the water rinse shows freedom from "water breaks," that is, when the water wets the entire surface.

b. Preparation the stripping solution. Twenty grams (20 g) of antimony trioxide (Sb_2O_3) or 32 g of antimony trichloride ($SbCl_3$) shall be dissolved in 1,000 milliliters (ml) of concentrated hydrochloric acid (HC1) having a specific gravity of approximately 1.19. To prepare the zinc stripping solution, 5 ml of the antimony chloride solution shall be added to each 1,000 ml of concentrated hydrochloric acid having a specific gravity of approximately 1.19.

c. Cleaning procedure. The specimen cleaned in accordance with Table C13 shall be weighed to the nearest 0.01 g.

(1) The zinc coating shall be stripped from the weighted specimen by immersing it in the stripping solution until the evolution of hydrogen ceases, or until only few bubbles are evolved. If the vessel used for the stripping bath is of small size, the specimen shall be loosely coiled to facilitate complete immersion. The temperature of the stripping solution shall at no time exceed 100°F. The same solution may be repeatedly used without further additions of antimony chloride solution until the time for stripping becomes inconveniently long.

(2) After stripping, the specimen shall be washed and scrubbed under running water and dried.

(3) The weight of the stripped specimen shall be determined to the nearest 0.01 g.

(4) The diameter of the stripped specimen, in inches, shall be determined by taking the mean of two measurements at right angles to each other. The measurements shall be made to the nearest 0.001 in.

(5) The weight of zinc coating shall be calculated as follows:

$$A = (W_1 - W_2) / (W_2 \times d \times 163) \quad (C1)$$

where

A = weight of zinc coating in ounces per square foot of stripped wire surface

Table C13
Weight of Zinc Coating in Rope and Strand Wires Removed from Finished Rope

Galvanized at Finish Size		Drawn Galvanized Wire	
Wire Diameter, in.	Minimum Weight of Zinc Coating, ounce per square foot	Wire Diameter, in.	Minimum Weight of Zinc Coating, ounce per square foot
0.010 - 0.015	0.05	0.010 - .015	0.05
0.0155 - 0.27	.10	Over .015 - .028	.10
.028 - .047	.20	Over .028 - .060	.20
.048 - .054	.40	Over .060 - .090	.30
.055 - .063	.50	Over .090 - .140	.40
.063 - .079	.60		
.093 - .092	.70		
.093 - larger	.80		

W_1 = original weight of specimen

W_2 = stripped weight of specimen

d = diameter of stripped wire, in.

163 = constant

C-4. Tensile Strength

a. Ropes and strands. The strength of wire rope or strands shall be determined from the long samples. The accepted breaking strength shall be as shown in the applicable tables herein. The free length of wire rope or strand shall be as shown in Table C14. The rope ends shall be terminated in zinc-poured sockets or other approved attachments. A failure with less than the accepted breaking strength that occurs within three times the rope or strand diameter of the end attachment shall be considered "no test" and further testing shall proceed as though the test never occurred.

b. Main wires. From each short sample, no less than one specimen of each diameter of wire from each wire strand and not less than six specimens from each sample shall be selected and the tensile strength determined in accordance with ASTM E 1571. The free length of wires shall be not less than 10 in. The speed of the movable head of the testing machine under no load shall be not more than 1 in. per minute. The tensile strength of the main wires shall conform

to the tensile strength requirements shown in Table C15.

C-5. Torsion Test

a. Primary method. From each short sample not less than one specimen of each size of main wires from each strand shall be taken. The total number of specimens shall be not more than 25 percent of the total number of main wires. The distance between the jaws of the testing machine shall be $8 \pm 1/16$ in. One clamp in the testing machine shall be movable parallel to the axis of the tested wire, and an axial tensile force in accordance with Table C16 shall be applied to keep the tested wire straight during the test. The tested wire shall be twisted by rotating one or both of the clamps at a uniform rate of not more than 60 revolutions per minute. The wires shall not break when one end is held and the other rotated the number of revolutions (360 degrees) as shown in Table C17.

b. Alternative test procedure. Because the number of revolutions in the torsional test is proportional to the free length, the inspector may allow a free length before the test of $4 \pm 1/16$ in. for wires up to 0.040 in. in diameter or of $6 \pm 1/16$ in. for wires not more than 0.060 in. in diameter. Wire specimens with a free length of 4 in. shall not break when twisted one-half the number of revolutions shown in Table C17. Wire specimens with a free length of 6 in. shall not break when twisted three-fourths the number of

Table C15
Minimum Free Length of Wire Rope and Strand for Tensile Test

Size Range, in.	Recommended Length ¹ , ft (minimum)
1/64 - 1/4	2
5/16 - 3/4	4
7/8 and larger	6

¹ These lengths represent clear rope between attachments.

revolutions shown in Table C16. Testing shall be done in the same manner as described above.

C-6. Preformed Wire Rope

If the seizing at one end of the wire is removed, the difference between the nominal diameter of the wire rope and the nominal diameter before seizing is removed shall be not more than the values given in Table C18.

Table C16
Tensile Strength Requirements of Main Wires Removed from Finished Rope

Material	Tensile Strength, minimum	
	Uncoated or Drawn Galvanized	Galvanized at Finish Size
Designated Commercially as:	lb/in ²	lb/in. ²
Iron	700,000	55,000
Annealed Steel	--	60,000
Traction Steel	160,000	--
Improved Plow Steel		
0.030 in. diameter and smaller	244,000	219,000
.031 - .060 in.	238,000	214,000
.061 - .100 in.	230,000	207,000
.101 - .140 in.	225,000	202,000
.141 - .190 in.	218,000	196,000
.191 - .250 in.	209,000	--
Extra Improved Plow Steel:		--
0.030 in. diameter and smaller	268,000	--
.031 - .060 in.	262,000	--
.061 - .100 in.	253,000	--
.101 - .140 in.	248,000	--
.141 - .190 in.	240,000	--
.191 - .250 in.	230,000	--
Phosphor bronze	90,000	--
Corrosion resistant steel	205,000	--

Table C17
Tensile Force on Wires During Torsional Test

Wire Diameter, in.		Tensile Force, lb	
From	To	Minimum	Maximum
0.000	0.009	0.5	1
.010	.014	1.0	2
.015	.019	1.5	3
.020	.029	2.0	4
.030	.039	3.0	6
.040	.049	4.0	8
.050	.059	5.0	10
.060	.069	6.0	12
.070	.079	7.0	14
.080	.089	8.0	16
.090	.099	9.0	18
.100	.109	10.0	20
.110	.119	11.0	22
.120	.129	12.0	24
.130	.139	13.0	26
.140	.149	14.0	28
.150	.159	15.0	30
.160	.169	16.0	32
.170	.189	19.0	38
.190	.209	22.0	44
.210	.229	25.0	50
.230	.249	28.0	56

Table C18
Torsion Values for Bright (Uncoated) and Drawn-Galvanized Main Wires Removed From Finished Rope

Material	Torsion (revolutions) per 100-wire diameter in length ¹
Extra improved plow steel	27.0 - 100 d ²
Improved plow steel	28.0 - 25 d ²
Traction steel	30.5 - 25 d ²

¹ To convert to torsions in 8 in., divide torsions in 100 d by 12.5 d.

² d = diameter of wire. Zinc coated (galvanized) at finished size main wires will not be required to meet these torsion values.

Table C19
Allowable Increases in Rope Diameter

Diameter before seizing is removed, in.	Increase in diameter after seizing is removed, in.
0 to 3/4	1/32
13/16/ to 1-1/8	3/64
1-3/16 to 1-1/2	1/16
1-9/16 to 2-1/4	3/32
2-5/16 and larger	1/8

Appendix D Terminations and Efficiencies

The most frequently used terminations for wire rope are shown in Figure D-1. The approximate efficiencies for these terminations (Figure D-2) are based on the nominal strength of the various sizes of wire rope.

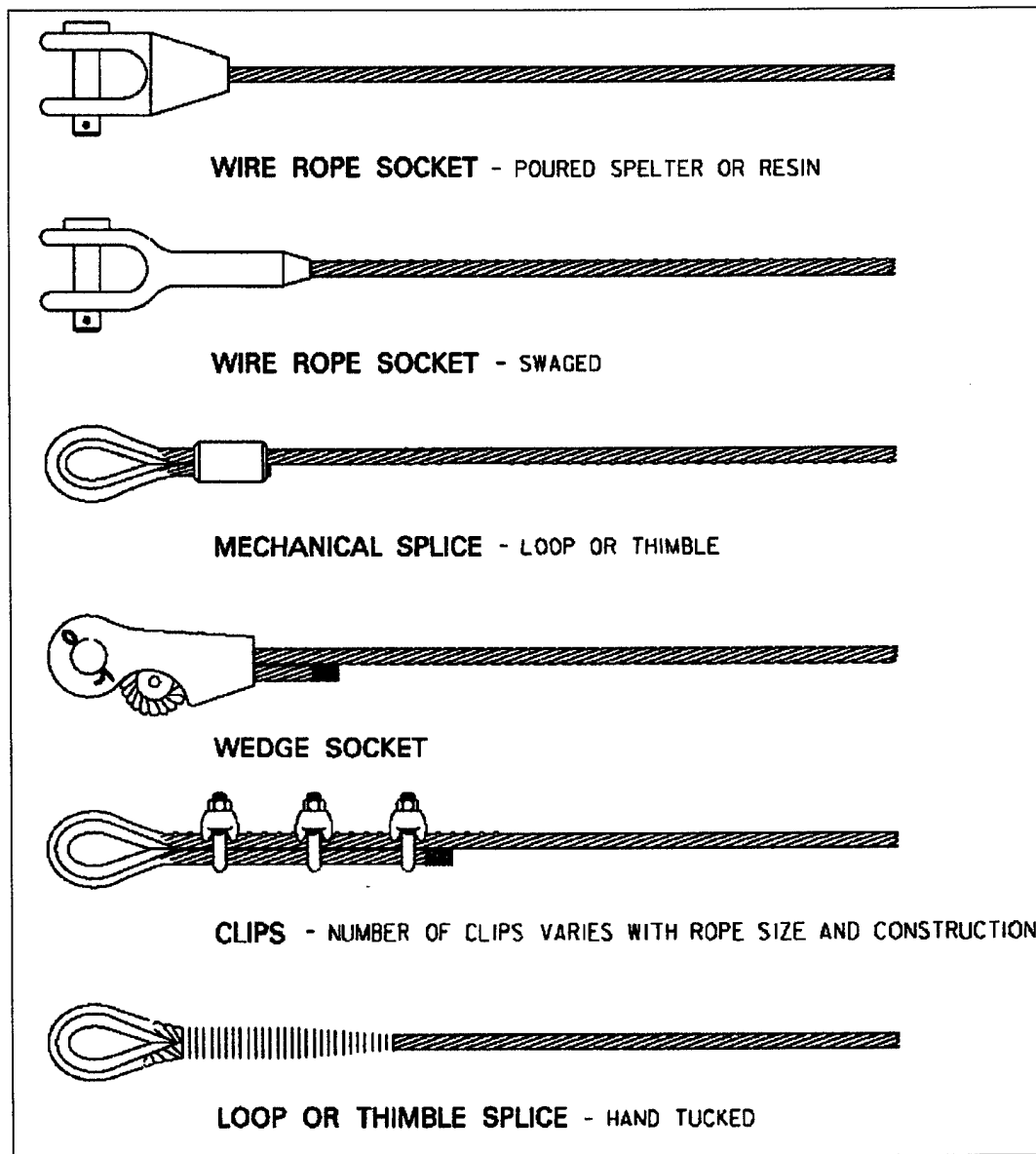

Figure D-1. Frequently used terminations

Type of Termination	Efficiency	
	Rope with IWRC	Rope with FC
Wire Rope Socket (Spelter or Resin)	100%	100%
Swaged Socket (Regular Lay Ropes Only)	100%	(Not recommended)
Mechanical Spliced Sleeve (Flemish Eye) 1" dia. and smaller Greater than 1" dia. through 2" Greater than 2" dia. through 3 1/2"	95% 92 1/2% 90%	92 1/2% 90% (Not established)
Loop or Thimble Splice—Hand Spliced (Tucked) (Carbon Steel Rope) 1/2" 5/8" 3/4" 7/8" thru 2 1/2"	86% 84% 82% 80%	86% 84% 82% 80%
Loop or Thimble Splice Hand Spliced (Tucked) (Stainless Steel Rope) 1/2" 5/8" 3/4" 7/8"	76% 74% 72% 70%	
Wedge Sockets *	75% to 80%	75% to 80%
Clips **	80%	80%

* These values apply for properly installed wedge sockets. Refer to the wire rope users manual for installation.

** These values apply for properly installed clips. Refer to the wire rope users manual for installation.

Figure D-2. Approximate efficiencies for terminations of wire rope

Appendix E

Test Links and Tension Limiting Devices

E-1. Huntington District Letter

The following is from a Huntington District letter dated 6 September 1996 to the Omaha District. The subject is EM 1110-2-3200, Wire Rope Selection Criteria for Gate Operating Devices - Rope Tension Adjustments. Copies of the two enclosures follow (Figures E-1 through E-3). Paragraph 6 states:

A protective device called a force control switch is used on the anchor end of multi-part reeving such as the Emergency Gate Hoist Machinery (op. Cit. R. C. Byrd) and Bulkhead Cranes (You saw this type machine at Greenup Locks and Dam). This device electrically de-energizes the hoist should the tension be too high or low at the anchor end. Enclosed are two drawings. One is a typical schematic for the electrical controls and the other is a typical installation drawing of the switch at the anchor. An example of the manufacturer of such a device is Dillon (Staveley/Weigh-tronics, Inc Fairmont, MN).

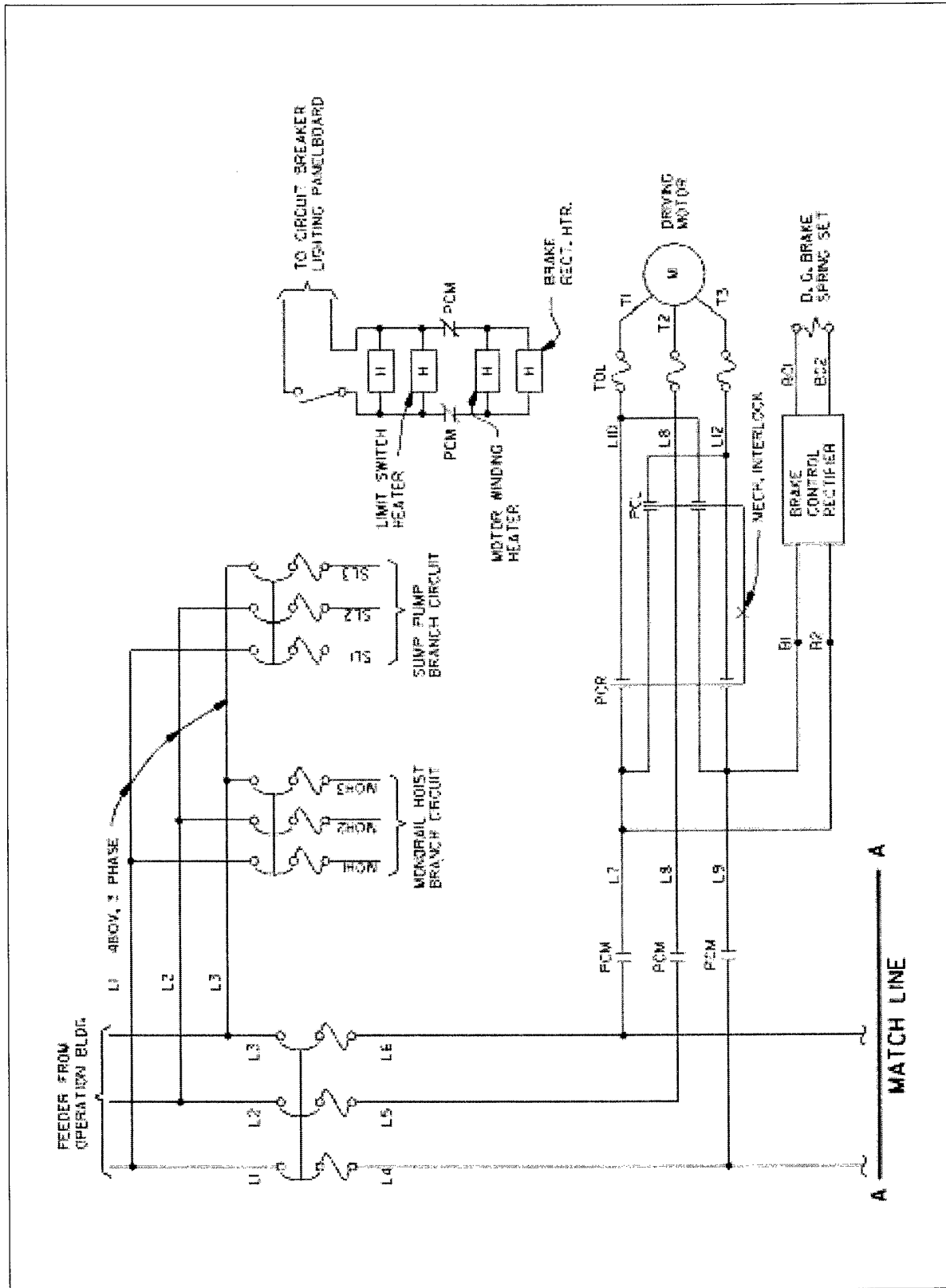

Figure E1. First portion of first enclosure from Huntington District letter

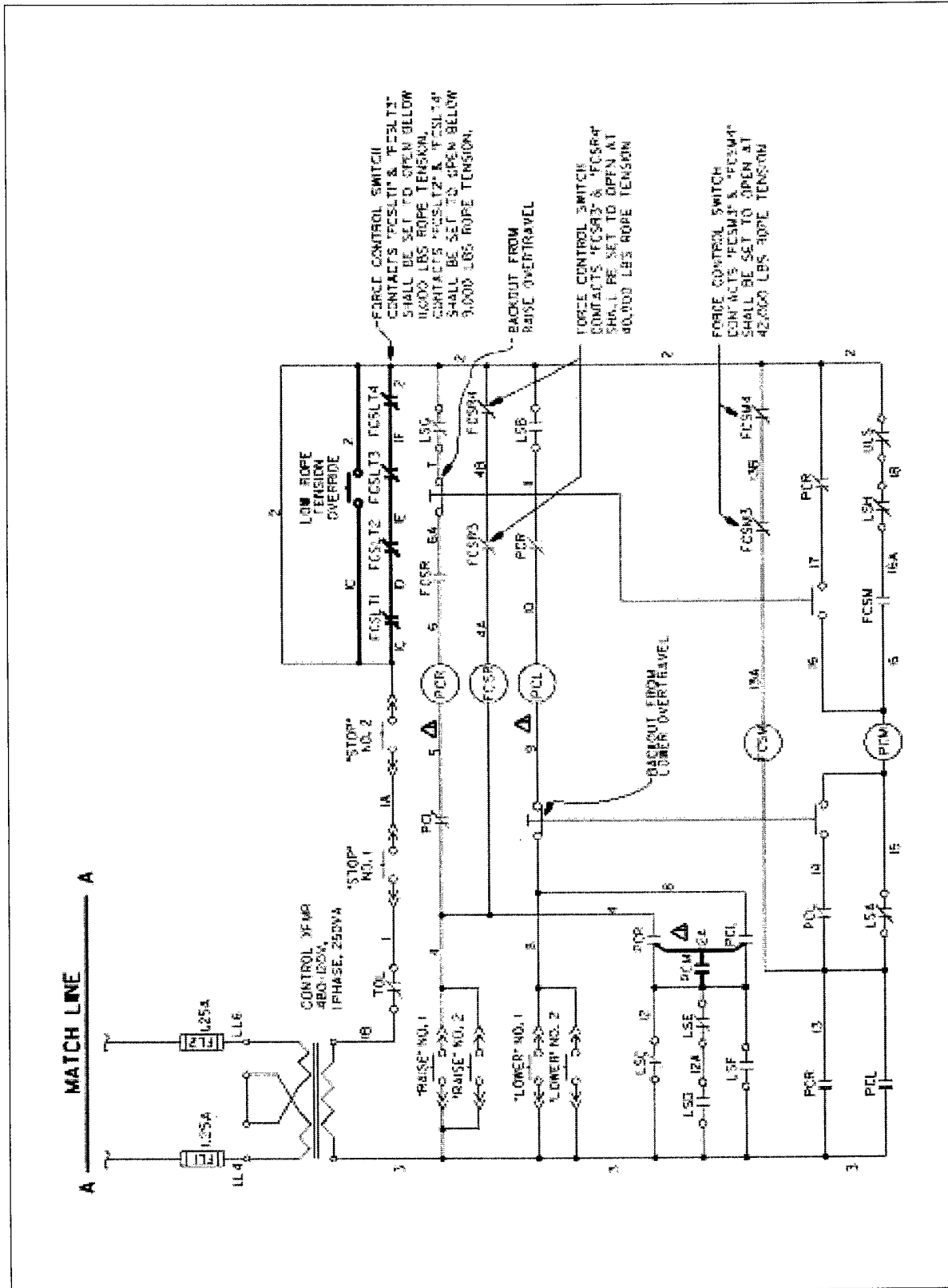

Figure E2. Second portion of first enclosure from Huntington District letter

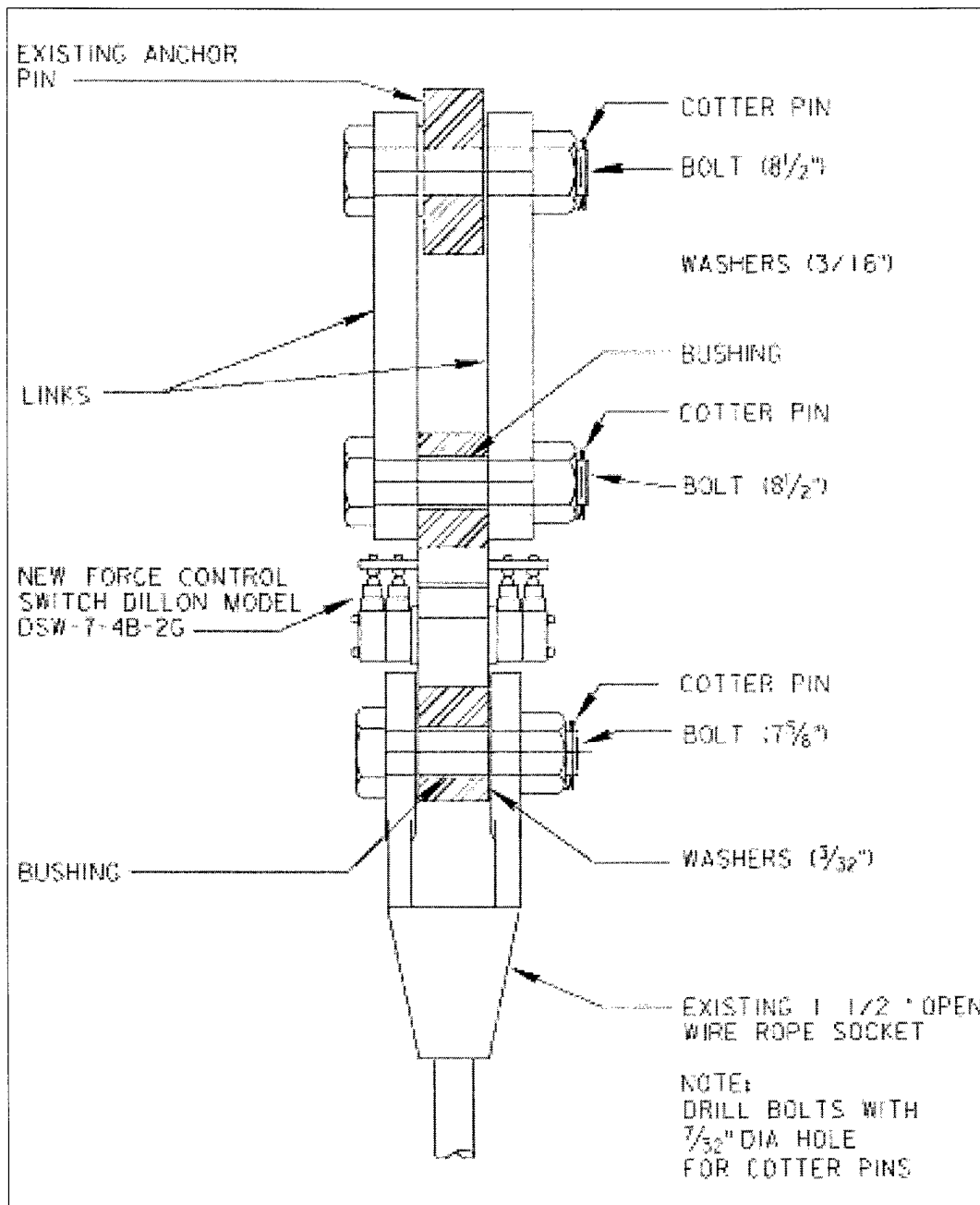

Figure E3. Second enclosure from Huntington District letter

Appendix F Kevlar Wire Rope

F-1. Corps of Engineers Experience with Kevlar Wire Rope

a. Huntington District. The Huntington District (April 1997) uses Kevlar wire rope for Stoney (roller slide type) gates at three lock and dam projects. Each project has four of these gates. In each case the 3/4-in. diameter Kevlar rope was a replacement for steel wire rope. The hoisting machinery and sockets were not changed.

(1) London Locks. The Kevlar wire rope has been in service since 1992. No failures have occurred.

(2) Marmet Locks. The Kevlar wire rope has been in service since 1992. The ropes on one of the gates failed during November 1995 after approximately 20,000 operations. The valve was not damaged. The ropes' appearance changed prior to failure. The cause of failure was judged to be fatigue.

(3) Winfield Locks. The Kevlar wire rope has been in service since 1993. The ropes on one of the gates failed during January 1997. The valve was not damaged. However, the failure was considered serious as repositioning of the valve was judged to be

effort which could be dangerous to the personnel involved. The failure appeared to be initiated as result of a rope's sheath becoming misshaped and getting tangled with a previous wrap on its spiral drum. During unwinding, the rope began winding in a reverse direction.

(4) Comments. Personnel at the Huntington District have decided the remaining spare Kevlar rope will be used for immediate replacement of any failed rope, but eventually the Kevlar rope will be replaced with stainless steel rope. The Kevlar rope gave better service than the original steel rope. Part of the corrosion problem with the original steel rope was that it used stainless steel sockets resulting in galvanic corrosion.

b. Walla Walla District. The Walla Walla District (April 1997) uses Kevlar wire rope for the radial lock gates at the Lower Granite project. The gate is operated 1,000 to 1,500 times per year. It was previously fitted with a 1-in. diameter stainless steel wire rope which had failed in as quickly as 6 months. The apparent mode of failure was fatigue from bending as the portion of the rope making the tightest bend on the spiral drum was the first to fail. At this time the Kevlar ropes had been in service for 4-5 years without a failure. Note that the spiral drums were modified slightly to reduce abrasion to the rope.

Appendix G
Sample Inspection Report Checklist

INSPECTION RECORD OF WIRE ROPE AND ACCESSORIES
GATE-LIFTING DEVICES

1 IDENTIFICATION DATA

1.1 Project _____

1.2 Gate Type _____

1.3 Gate Location _____

1.4 Gate Number _____

1.5 Date _____

1.6 Inspector _____

2 CONDITION OF ROPE

2.1 Which Rope(s)? _____

2.2 Diameter Reduction. *What is the rope's current diameter? (Under constant load & at the reference location, graph time vs reduction.)*

2.3 Stretch. *How much has the rope stretched? (Under constant load, graph time vs stretch.)*

2.4 Abrasion. *How much (percent) reduction in outer wire diameter?*

2.5 Broken Wires. *Maximum number per lay and per strand?*

2.6 Corrosion. *Describe any corrosion, and give locations.*

2.7 Other Damage. *Is there any evidence of peening, scrubbing, kinks, bird caging, or any other damage occurring in a localized area, and if so, describe?*

2.8 Potential Over-Stressing. *Have any incidents occurred which could potentially have stressed the rope above its design load, describe?*

3 ROPE FITTINGS

3.1 Which Fittings? _____

3.2. Wear. *Describe any wear.*

3.3 Cracks. *Are there any cracks?*

3.4 Broken Wires. *Has more than one wire failed adjacent to any fitting?*

4 SHEAVES, PULLEYS, & DRUMS

4.1 Which one(s)? _____

4.2 Groove Diameters. *Are the groove diameters within tolerance? (Measure with "go/no-go" gauges.)*

4.3 Wear Patterns. *Describe any wear patterns in the grooves.*

4.4 Other. *Are there any broken flanges, wobble in the bearings, broken flanges, flat spots, or off center grove wear?*

EM 1110-2-3200

30 Sep 98

Notes: (1) Reference: Chapter 7 of EM 1110-2-3200. (2) The condition of the wire rope and its accessories should be assessed both in absolute terms and in comparison to previous inspections. (3) Attach sketches or additional sheets if more room is needed.

Appendix H Lubrication and Lubricant Data

H-1. Information Provided by Various Corps Offices

The following items of information were provided from various Corps offices and are included to assist readers in solving lubrication problems.

a. Item No. 1. Taken from correspondence from Mr. Waite of Broderick and Bascom Rope Company regarding lock gates at Melvin Price Lock and Dam, Alton, Illinois. A number of questions were addressed subsequent to a site visit by one of their personnel.

(1) Gate and rope type. Multi-leaf lift gates/1-1/2", 6x30G Fattened Strand, Type 304 Stainless Steel, Right Lay Regular Lay IWRC. "Cables run in dirty, debris-filled, river water," per St. Louis District.

(2) Problem/solution. A quotation regarding lubrication: "We recommend lubricating the wire rope with a field dressing. The field dressing we recommend is Witco Allied Kelite X-38-AC. A typical specification listing for the compound is attached. We suggest covering the tension members with X-38-AC to prevent corrosion from bird droppings. This is a penetrating type of lubricant. The proper interval is related to the degree of difficulty required to clean it off for inspection, and its tenacity against water, etc. We suggest beginning with a light application monthly, and then rationalizing the frequency of application, based on experience."

(3) Additional information. The manufacturer claims that "X-38-AC is a low viscosity, solvent reduced dressing designed to provide protection in either acid or salt environments. Once its solvent carrier evaporates, X-38-AC sets to a pliable film which resists moisture infiltration and throw-off." For more information:

Allied-Kelite, A Witco Company
5301 West 66th Street, Chicago, IL 60638
(312)767-8447

b. Item No. 2. Information from the St. Louis District which was sent to Omaha District regarding lock gates at Melvin Price Lock and Dam.

(1) Gate and rope type. Multi-leaf lift gates/1-1/2", 6x30G Fattened Strand, Type 304 Stainless Steel, Right Lay Regular Lay IWRC.

(2) Problem/solution. The problem was that most lubricants are opaque and make wire rope inspection difficult. The St Louis District tried two transparent lubricants, ALMASOL 2001 and ALMASOL 2002. Apparently they are satisfied with the results.

(3) Additional information. ALMASOL 2001 is for the inside of the rope and the manufacturer claims it ". . . is a highly penetrating fluid lubricant with excellent load carrying capacity. Designed to penetrate to and throughout the core of wire ropes either standing or running. . . Contains a petroleum solvent to enhance penetration capabilities . . ." ALMASOL 2002 is for the outside of the rope and the manufacturer claims it is "A fluid, coating wire rope lubricant which provides a non-tacky durable self-healing film to reduce wear and corrosion under extreme conditions of load and moisture." For more information:

Lubrication Engineers, Inc.
3851 Airport Freeway, P.O. Box 7128
Fort Worth, TX 76111
(817)834-6321

c. Item No. 3. Information from the Seattle District which was sent to Omaha District regarding lubrication of wire ropes at Albeni Falls Dam and Lake Washington Ship Canal.

(1) Gate and rope type. The lubricated wire ropes at both Albeni Falls Dam and at the Lake Washington Ship Canal are for cranes but are not otherwise specified.

(2) Problem/solution. Apparently a number of rope test sections were lubricated with various lubricants at Albeni Falls Dam. They ". . . have since used Lubriplate Chain and Cable Fluid PT 13539, as

it looked good in our test, appears to soak well, and seems to provide good protection without all the mess." At the Lake Washington Ship Canal they use a product called Silver Spur with moly-disulfide, manufactured by Dynaco. They state, "... we have seen extremely good results with this product. We have been using the product for approximately 5-7 years and have seen little, if any, deterioration due to rust/corrosion. We have looked into biodegradable products, but have as yet to find out which will hold up well under our weather and load characteristics."

d. Item No. 4. Information from the Portland District which was sent to Omaha District regarding lubrication of wire ropes.

(1) Gate and rope type. Not specified.

(2) Problem/solution: From fax: "Many projects throughout the COE use standard oil-based lubrication for wire rope which when put into waterways leaves a sheen of oil on the surface as well as pollutes the water in general. This unacceptable practice will continue until the projects are provided with an effective wire rope lubricant that is acceptable to the Environmental Protection Agency. One such lubricant that appears to have possibilities is:

PRELUBE 19 as sold by Grinard Company Inc.
900 Port Reading Avenue
P.O. Box 221
Port Reading, New Jersey 07064
Tel (908) 541-6661 Fax (908) 541-1918

This lube has been used in the oceans by the USCG and Oregon State University, College of Oceanography. Both have had good results concerning corrosion protection, center penetration, and no apparent wash off. Contact company above for MSDS and additional test results."

e. Item No. 5. Information from the Lower Mississippi Valley Division which was sent to Omaha District regarding lubrication of wire ropes.

(1) Gate and rope type. Sector gates at Bayou Dupre, Bayou Bienvenue, Golden Meadow, and

Larose all with 1-1/8" diameter, 6x37 fiber core, Type 1, Class 3 in accordance with Fed Spec RR-W-410A.

(2) Problem/solution. The letter stated, "... the wire rope is not submerged or in direct contact with the water. The major problem with wire rope on these structures is that they require a heavy grease coating to reduce corrosion. Because the wire rope runs horizontally in front of the gates and through the machinery pits and the grease is fluid in warm weather, there is a constant problem with grease drippings along the front portion of the gates and over a good portion of the machinery pit. Considering the infrequent use of the structures and the problems with the grease, stainless steel wire rope should have been used."

f. Item No. 6. Information from the Vicksburg District which was sent to Omaha District through LMVD regarding lubrication of wire ropes.

(1) Gate and rope type. Not specified.

(2) Problem/solution. The letter stated, "Changed . . . to Certified CCX77 lubricant. For wire rope that had been changed every 5 years, we were able to extend the life to 7 years due to better penetration . . . does not have to be heated to be applied, resulting in safer working conditions."

g. Item No. 7. An Omaha District trip report concerning a visit to Oahe Dam outlet works, dated August 1973.

(1) Gate and rope type. Vertical lift gates/1-1/4", 6X37 IWRC Galvanized Improved Plow Steel.

(2) Problem/solution. The visit was scheduled to include an inspection of the outlet service gate wire ropes with respect to corrosion. Gate Nos. 2 and 3 ropes, which had never been lubricated were compared to the Gate No. 4 rope which had been lubricated soon after installation (and never since). These gates/ropes were in service approximately 15 years at the time of the inspection, and the results were as follows:

Gate No.	Lubricated	Broken Wires	Near Broken	Total
2	No	10	None	10
3	No	16	26	42
4	Yes	68	35	103

The conclusion was that "lubrication . . . appears to have done more damage than good." This conclusion appears valid as the average number of breaks plus near breaks for the non-lubricated ropes was 26 versus 103 for the lubricated rope. The report also mentioned that some of the lubricant is lost as a rope passes over sheaves and "This results in wire rope being substantially covered with lubrication but with substantial bare spots on the outer wires where contact was made with the sheave. Galvanic corrosion is then concentrated in these areas. This is evident when viewing the corroded areas . . . More frequent lubrication intervals may have increased the life of the rope by changing the bare spots on the wire rope where the concentrated corrosion starts."

(3) Additional information. In July 1966 a Missouri River Division issued a letter, subject:

Lubrication of Stainless Steel Hoist Cables. This letter recommended against lubricating stainless steel wire rope.

h. Item No. 8. Telephone call from Seattle District.

(1) Gate and rope type. Not specified.

(2) Problem/solution. The Seattle District has been using a lubrication system which contains the rope and pumps lubricant into it and have been satisfied with the results.

(3) Additional information. For more information contact:

The Kirkpatric Group
401 S. Sherman Street, Suite 211
Richardson, TX
(972) 669-9988.

Appendix I Methods for Deicing

I-1. Gate Wall Heaters

The Omaha District is currently (April 1997) producing drawings and specifications for gate wall heaters for the spillway tainter gates at Gavins Point Dam. Ice formations on the downstream side of the gates frequently prevent the gates from being lifted. The gate wall heaters which were previously installed were metal sheathed plastic with imbedded heating elements. They worked well in preventing ice from bridging between the gates and the gate walls. However, the heating elements have begun to fail. The new heaters will be of metal construction with replaceable heating elements (Figure I-1).

I-2. Aircraft Deicer

a. Demonstration. A truck-mounted aircraft deicer having an extendable, articulated boom and personnel basket, was used in a deicing demonstration in 1985 at the Gerald Gentleman Power Station located near Sutherland, Nebraska. Observers from the Omaha District were present. An 8-ft-high x 8-ft-wide x 2-ft-thick ice formation was cut from a concrete structure in about 30 minutes (rather than being melted away in its entirety). The nozzle was adjusted to spray a narrow stream of 200° F water at about 30 gpm. The operator was only a few feet away from the ice.

b. Application. The observers concluded this type of equipment would be applicable for deicing the

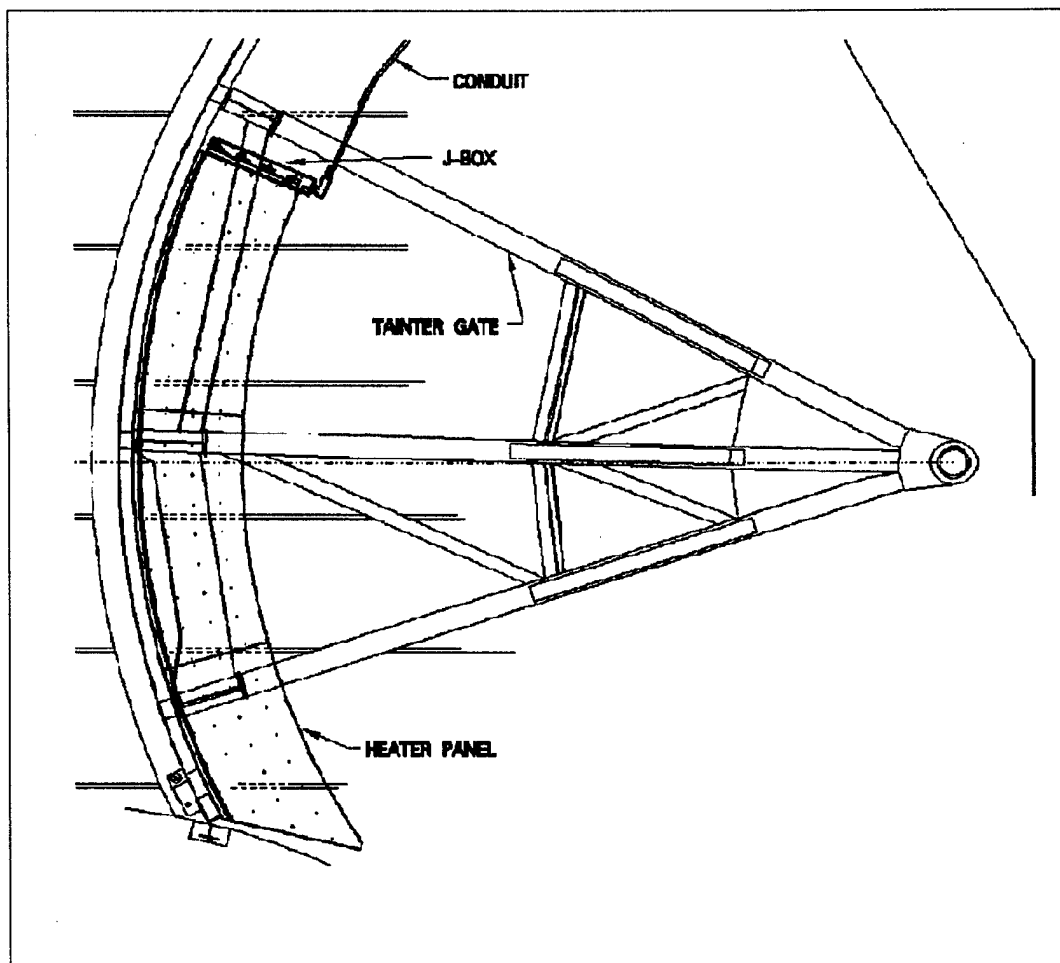

Figure I-1. Gate wall heaters

EM 1110-2-3200
30 Sep 98

spillway gates at Gavins Point Dam. Provisions would be required to station the operator close to the ice as the water cools at a rate of about 2° F per ft after leaving the nozzle, and a narrow stream is required for cutting ice. The deicing equipment could also be installed on a truck without the boom and personnel basket, or on a trailer, or be designed for installation at a permanent location.

I-3. Cold Regions Research And Engineering Laboratory (CRREL)

Among some of the possibilities for deicing are side panel heaters, bubbler systems, steam boilers, high

density polyethylene cladding, and vibrators. CRREL has done some work on gate deicing and should have advice on most of these options. For information contact:

Robert B. Haehnel
Department of the Army, Corps of Engineers
Cold Regions Research and Engineering
Laboratory
Hanover, New Hampshire 03755-1290
Tel (603) 646-4184
Fax (603) 646-4477

Appendix J Sample Problem

J-1. Problem Description

A six-year-old wire rope used on a frequently used gate-lifting device located in a warm, humid freshwater environment is inspected. The inspection reveals that the rope is near failing from corrosion as there are many large corrosion pits and rusty areas. The inspection also indicates fatigue is a problem as many broken wires are present. There is no indication of abrasion.

J-2. Equipment Description/Analysis

a. *Drum/sheave arrangement.* 10-part as shown in Figure J-1.

b. *Sheave pitch diameter.* 45 inches.

c. *Sheave bearings.* Plain.

d. *Maximum load (gate weight, friction draw down, etc):* 132 tons.

e. *Rope:* 1-1/2-in. 6x30G flattened strand, right regular lay, improved plow steel (uncoated), IWRC.

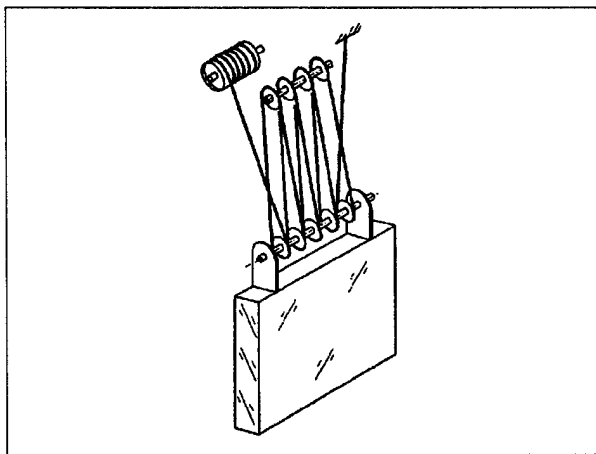

Figure J-1. Drum/sheave arrangement

Per Chapter 4, Figure 4-3, the dynamic rope tension is 0.156 of the load for a lift mechanism with a 10-part sheave arrangement. Therefore, dynamic rope tension would be:

$$0.156 \times 132 \text{ tons} = 20.6 \text{ tons}$$

Per Appendix C Table 8, the nominal strength of the existing rope was 119 tons when new, and per Chapter 4, Figure 4-5, the 30:1 D/d ratio for bending over the sheaves results in a rope efficiency of 0.95. Therefore, the factor of safety for the existing rope when new was:

$$(119 \text{ tons}/20.6 \text{ tons}) \times .95 = 5.5 \text{ FOS}$$

In short, the factor of safety is adequate for the requirements given in Chapter 4, Paragraph 4-5, and the bending radius is the minimum recommended in Chapter 4, Figure 4-11 (for 6x30 G Flattened Strand rope). It appears the rapid corrosion was caused by the humid environment and fatigue resulted from frequent use of the gate.

J-3. Potential Solutions

a. A first thought may be to replace the existing rope with a one of a similar construction but of stainless steel instead of improved plow steel, since Chapter 2, Paragraph 2-5, states that "The stainless steels are many times more corrosion resistant than the carbon." However, this paragraph also states that with stainless steels a 10 to 15 percent loss in strength should be expected. Compared to the 5.5 factor of safety for the existing rope when new, a new rope of the same construction, but of stainless steel (with a 15 percent strength reduction) would have a 4.7 factor of safety, which is lower than required according to Chapter 4, Paragraph 4-5. In addition, the inspection revealed many broken wires, which is a sign of fatigue. Merely changing to stainless steel would not reduce fatigue.

b. Given the same load, fatigue could be reduced by changing to lang lay construction. Per Chapter 2, Paragraph 2-2, lang lay rope has better resistance to fatigue while it is equal in strength. It tends to rotate in use, but this is not a problem if both ends are constrained.

c. Also, fatigue could be reduced by changing to a configuration with smaller wires such as 6x37. Note that as previously stated, the bending radius of 30:1 is the minimum recommended for 6x30 G flattened

strand rope. The minimum bending radius for 6x37 according to Chapter 4, Figure 4-11, is 26:1. From Chapter 4, Figure 4-12, it would appear this increase from minimum could produce a significant reduction in fatigue. Normally smaller wires would increase corrosion, but in conjunction with a change to stainless steel, this would not likely be a problem.

d. A significant problem would be the loss of strength. A 1-1/2-inch rope of 6x37 IWRC construction and of improved plow steel has a nominal strength of 99 tons according to Appendix C, Table C4. This 17 percent strength reduction would result in a factor of safety of 4.6 for the same rope tension. Combined with a 15 percent strength reduction for changing to stainless steel, the factor of safety would only be 3.9 for the same rope tension.

e. It would appear that changing to a stainless steel rope of 6x37 IWRC construction would solve both the corrosion and fatigue problems except that the factor of safety would be lower than required. Note that the sheaves use plain bearings. As stated in Chapter 4, Paragraph 4-4, the rope tension for sheaves with plain bearings can be much higher than for sheaves with roller bearings. Chapter 4, Figure 4-3, shows that the rope tension for the existing 10-part

plain bearing sheave is 0.156 of the load. Therefore, rope tension with a plain bearing sheave is calculated using the following equation:

$$0.156 \times 132 \text{ tons} = 20.6 \text{ tons} \quad (\text{J-1})$$

If the sheave were replaced or modified to use roller bearings, Chapter 4, Figure 4-3, indicates the rope tension would be 0.123 of the load. Tension is calculated using the following:

$$0.123 \times 132 \text{ tons} = 16.2 \text{ tons} \quad (\text{J-2})$$

The factor of safety for a stainless steel rope of 6x37 IWRC lang lay construction combined with a roller bearing sheave would then be as follows:

$$(99 \text{ tons}/16.2 \text{ tons}) \times .95 = 5.8 \text{ FOS} \quad (\text{J-3})$$

The factor of safety of 5.8 is better than required.

f. Further investigation would be required to determine if modifying the sheaves to use roller bearings is the cost effective solution. Also, before proceeding with this solution, it would be wise to contact technical specialists at wire rope companies to see if they agreed that this is a solution to the problem.

Index

This index is organized alphabetically by topic and by subtopic within topic. Topics and subtopics are identified by paragraph number unless otherwise indicated.

Abrasive wear		Sockets	3-1
General	2-1, 4-1	Specially shaped rope	2-3
Inspection	7-1	Diameter	
Availability	5-3	Grooves	6-1
Bearing pressure	4-9	Ropes	6-1, 7-1
Bending radii	4-8	Dogging device	4-4
Blending wires	2-8	Drum	
Brass wires	2-5	Anchorages	3-3
Break-in	6-3	Installation	6-3
Bronze wires	2-5	General	4-1, 4-9
Carbon steel wires	2-5	Ductility, of wires	5-2
Classification	2-1	Dynamometer test	6-3
Coatings	2-7	Factor of safety	4-5
Compacted strand rope	2-3	Failure modes	4-1
Construction	Chapter 2	Fatigue	2-1, 4-1
Cost	5-3	Filling with plastic	2-7
Cores	2-6	Flat rope	2-4
Corrosion		Fleet angle	4-10
Cathodic protection	7-6	Flattened wire rope	2-3
General	4-1	Flexibility and class	2-1
Inspection	7-1	Flexibility and lay	2-2
Versus class	2-1	Galvanizing	2-7
Versus lay	2-2	Handling	6-1
Versus material	2-5	Ice removal	7-4
Painting	7-5	Inspection	Chapter 7
		Kevlar	2-5
		Lay	2-2
		Load calculations	4-2, 4-3

EM 1110-2-3200
30 Sep 98

Lubrication	5-2, 7-3	Proof testing	5-2
		Speltered	3-1
Manufacturing	2-8	Swaged	3-1
Nominal strength	4-4	Splicing	3-4
Nomenclature, standard	5-1	Stainless steel	2-5
Part-number	4-3	Storage	6-2
Peening	7-1	Strand	Chapter 2(Intro.), 2-1
Pitch length	5-2		
Plating	2-7	Stress, excessive	4-1
		Stress, relieving	2-8, 5-2
Preforming		Stretch, Rope	
General	2-8	General	4-7
Test for	5-2	Constructional	4-7
		Elastic	4-7
Pre-stretching		Versus life	7-1
General	2-8		
Test for	5-2	Swaged wire rope	2-3
Replacement Rope	4-1		
Reserve strength	4-4	Tensioning	2-8, 6-3
Rollers	4-1	Tension Test	5-2
Saltwater	2-5	Terminations	
Scrubbing	7-1	General	3-3
Seizing	3-4	Efficiency of	4-5
Service conditions	4-1	Torsion rest	5-2
Service life	4-6	Unreeling	6-2
		Weaving	2-8
Sheaves		Weld distribution	5-2
General	4-1	Wire materials	2-5
Efficiency loss	4-5		
Load calculations	4-3	X-chart	2-1
Socketing	2-8, 3-3		
Sockets			
General	Chapter 3		
Materials	3-2		