

CECW-ED Engineer Manual 1110-2-3001	Department of the Army U.S. Army Corps of Engineers Washington, DC 20314-1000	EM 1110-2-3001 30 April 1995
	Engineering and Design PLANNING AND DESIGN OF HYDROELECTRIC POWER PLANT STRUCTURES	
	Distribution Restriction Statement Approved for public release; distribution is unlimited.	

DEPARTMENT OF THE ARMY
U.S. Army Corps of Engineers
Washington, DC 20314-1000

EM 1110-2-3001

CECW-ED

Manual
No. 1110-2-3001

30 April 1995

**Engineering and Design
PLANNING AND DESIGN OF HYDROELECTRIC
POWER PLANT STRUCTURES**

1. Purpose. This manual provides guidance for structural planning and design of hydroelectric power plants.

2. Applicability. This manual applies to HQUSACE elements, major subordinate commands, districts, laboratories, and field operating activities having responsibility for design of civil works projects.

FOR THE COMMANDER:

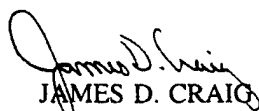
JAMES D. CRAIG
Colonel, Corps of Engineers
Chief of Staff

20020628 208

This manual supersedes EM 1110-2-3001, dated 15 December 1960.

**DEPARTMENT OF THE ARMY
U.S. Army Corps of Engineers
Washington, DC 20314-1000**

EM 1110-2-3001

CECW-ED

Manual
No. 1110-2-3001

30 April 1995

**Engineering and Design
PLANNING AND DESIGN OF HYDROELECTRIC
POWER PLANT STRUCTURES**

Table of Contents

Subject	Paragraph	Page	Subject	Paragraph	Page
Chapter 1			Interior Details		
Introduction		 3-4		
Purpose and Scope	1-1	1-1	Schedule of Finishes		
Applicability	1-2	1-1 3-5		
References	1-2	1-1	Painting		
Codes	1-4	1-1 3-6		
Criteria	1-5	1-1	Design Memorandum		
Hydroelectric Design Center	1-6	1-1 3-7		
Chapter 2			Drawings		
General Requirements		 3-8		
Location of Powerhouse	2-1	2-1	Chapter 4		
Location of Switchyard	2-2	2-1	Structural Requirements		
Highway and Railroad Access	2-3	2-1	Design Stresses		
Other Site Features	2-4	2-1 4-1		
Types of Powerhouse			Design Loads		
Structures	2-5	2-1 4-2		
Selection of Type of			Stability Analysis		
Powerhouse	2-6	2-2 4-3		
General Arrangement of			Subgrade Conditions and		
Powerhouse	2-7	2-2	Treatments		
Location of Main		 4-4		
Transformers	2-8	2-3	Foundation Drainage and		
Powerhouse and Switchyard			Grouting		
Equipment	2-9	2-3 4-5		
Powerhouse Auxiliary			Substructure Functions and		
Equipment	2-10	2-4	Components		
Chapter 3		 4-6		
Architectural Requirements		 4-7		
Exterior Design	3-1	3-1	Waterstops		
Exterior Details	3-2	3-1 4-8		
Interior Design	3-3	3-2	Draft Tubes		
		 4-9		
			Spiral Cases		
		 4-10		
			Generator Pedestals		
		 4-10		
			Bulb Turbine Supports		
		 4-10		
			Types of Superstructures		
		 4-13		
			Superstructure-Indoor		
			Powerhouse		
		 4-14		
			Intakes		
		 4-15		
			Penstocks and Surge Tanks		
		 4-16		
			Switchyard Structures		
		 4-17		
			Reinforcing Steel		
		 4-18		
			Encasement of Structural		
			Steel		
		 4-19		
			Retaining Walls		
		 4-20		

Subject	Paragraph	Page	Subject	Paragraph	Page
Area Drainage	4-21	4-17	Tunnels in Rock Abutments	6-4	6-2
Chamfers, Grooves, and Rustications	4-22	4-17	Cut and Cover Conduits	6-5	6-2
Chapter 5			Free Standing Penstock Within Conduits	6-6	6-2
Physical Security					
Protection Plan	5-1	5-1	Appendices		
Chapter 6			Appendix A		
Retrofitting Existing Projects			References		
General	6-1	6-1	Appendix B		
Hydraulic Design			Tabulation of Generator and Turbine Data		
Considerations	6-2	6-1			
Geotechnical Considerations	6-3	6-2			

Chapter 1 Introduction

1-1. Purpose and Scope

This manual presents a discussion of the general, architectural and structural considerations applicable to the design of hydroelectric power plant structures. It is intended for the guidance of those elements within the Corps of Engineers responsible for the planning and design of such structures. It should also be used in establishing minimum criteria for the addition of hydro-power facilities at existing Corps of Engineers projects, whether by Corps of Engineers or a non-Federal developer.

1-2. Applicability

This manual applies to HQUSACE elements, major subordinate commands, districts, laboratories, and field operating activities having responsibility for design of civil works projects.

1-3. References

Required and related publications are listed in Appendix A.

1-4. Codes

Portions of the codes, standards, or requirements published by the associations or agencies listed below are applicable to the work.

- a. American Association of State Highway and Transportation Officials (AASHTO).
- b. Institute of Electrical and Electronics Engineers (IEEE).
- c. American Society of Civil Engineers (ASCE).
- d. American Society of Mechanical Engineers (ASME).
- e. National Board of Fire Underwriters (NBFU).
- f. National Bureau of Standards (NBS).
- g. National Electrical Manufacturers Association (NEMA).

- h. National Fire Protection Association (NFPA).

1-5. Criteria

The design methods, assumptions, allowable stresses, criteria, typical details, and other provisions covered in this manual should be followed wherever practicable. However, it is expected that judgment and discretion will be used in applying the material contained herein. It is realized that departures from these standards may be necessary in some cases in order to meet the special requirements and conditions of the work under consideration. When alternate methods, procedures, and types of equipment are investigated, final selection should not be made solely on first cost but should be based on obtaining overall economy and security by giving appropriate weight to reliability of service, ease of maintenance, and ability to restore service within a short time in event of blast damage or radiological contamination. Whether architect-engineers or Hydroelectric Design Center personnel design the power plant, the criteria and instructions set out in Appendix A of guide specification CE-4000 should be followed.

1-6. Hydroelectric Design Center

a. *Utilizing installations.* The engineering of hydroelectric projects is a highly specialized field, particularly the engineering design and operational activities. In order to assist field operating activities (FOA), the Corps of Engineers has established a Hydroelectric Design Center (HDC), located at Portland, Oregon, for utilization for all hydroelectric installations, including installations at existing dams.

b. *FOA services.* The FOA will retain complete responsibility and authority for the work, including funding, inspection, testing, contract management, and administration. The HDC will perform the following engineering and design services in accordance with ER 1110-2-109:

- (1) Provide the technical portions of reconnaissance reports and other pre-authorization studies for inclusion by the requesting FOA in the overall report.
- (2) Provide the architectural, structural, electrical, and mechanical design for the powerhouse including switchyards, related facilities, and all hydraulic transient studies.
- (3) Prepare preliminary design reports and the feature design memoranda for hydroelectric power plants for the requesting FOA.

EM 1110-2-3001
30 Apr 95

(4) Prepare plans and specifications for supply and construction contracts and supplemental major equipment testing contracts.

(5) Provide technical review of shop drawings.

(6) Provide technical assistance to the Contracting Officer's representative at model and field tests. The HDC will analyze results and make recommendations.

(7) Assist in preparation of Operation and Maintenance Manuals.

(8) Provide necessary engineering and drafting to transfer "as-built" changes to "record" tracings and ensure complete coordination of such changes.

(9) Participate in review of plans and specifications for non-federal development at Corps of Engineers projects in accordance with ER 1110-2-1454.

Chapter 2 General Requirements

2-1. Location of Powerhouse

a. Determining location. The location of the powerhouse is determined by the overall project development. The factors affecting the location include:

- (1) Location of the spillway (when powerhouse is located adjacent to the dam).
- (2) Location of navigation locks (on navigation projects).
- (3) Foundation conditions.
- (4) Valley width.
- (5) River channel conditions below dam.
- (6) Accessibility.
- (7) Location of switchyard and transmission lines.

b. Local conditions. At projects where the powerhouse is located at the dam adjacent to the spillway, local condition such as width of flood plain, accessibility, and depth of foundations will usually govern the location. On projects which will include a navigation lock, the powerhouse is preferably located at the opposite end of the spillway from the lock. Where the river channel below the dam has an appreciable fall, economic studies should be made to determine whether a remote powerhouse location downstream from the dam is justifiable.

c. Sub-structures. At low-head projects, the substructure of the powerhouse may be wholly or partially incorporated into the design of the intake structure. At medium-head plants, the substructures of the generating units and the upstream generator room wall should be separated from the toe of a concrete dam, and any part of the powerhouse supported thereon, by a formed joint. See paragraph 4.7 for additional joint details. The amount of separation between the powerhouse substructure and the toe of the dam at, or below, the elevation of the generator room floor may be dependent upon the foundation conditions, but the separation is frequently as much as 10 feet or more to provide adequate space to install service facilities.

2-2. Location of Switchyard

The availability of suitable space will, in a great many cases, determine the location of the switchyard. Consideration should be given to the number and direction of outgoing transmission lines. The elevation of the switchyard should be established above design high tailwater. The most desirable and economical location is usually adjacent to or near the powerhouse.

2-3. Highway and Railroad Access

In planning the development of the site, both highway and railroad access to the powerhouse, switchyard, and other structures should be considered. Highway access to the plant should usually be provided. At plants where large generating units are to be installed, an access railroad should be considered if feasible and economically justified, consideration being given to utilizing the railroad connection which will usually be required for construction of the dam. Trucking costs from the nearest rail point, together with all handling costs should be compared with the cost of constructing and maintaining a railroad to the plant. The location of the highway or railroad access into the powerhouse will be determined by the approach conditions in the valley and the arrangement of the powerhouse. The access facilities should, where possible, be located so that their use will not be impaired by design high water. It is not essential that the railroad entrance be located above high water, especially where the flooding period would be of short duration; however, provision for bulkheading of the railroad entrance should be provided, and an access protected from design high-water conditions should be provided for personnel.

2-4. Other Site Features

Area should be provided for both public and employee parking. Sidewalks, guard rails, fences, locked gates, parapets, and other safety features should be included in the general plan. Adequate drainage, a water supply, and lighting should be provided in the areas near the powerhouse. Landscaping should also be considered in the studies of the site development.

2-5. Types of Powerhouse Structures

Three types of powerhouses classified as to method of housing the main generating units are described:

a. Indoor type. The generator room is fully enclosed and of sufficient height to permit transfer of equipment by means of an indoor crane.

b. Semi-outdoor type. The generator room is fully enclosed but the main hoisting and transfer equipment is a gantry located on the roof of the plant and equipment is handled through hatches.

c. Outdoor type. In this type there is no generator room and the generators are housed in individual cubicles or enclosures on, or recessed in, the deck.

2-6. Selection of Type of Powerhouse

This determination will be made on the basis of an economic analysis which takes into consideration, not only first cost, but operation and maintenance costs. While there is some structural economy inherent in outdoor and semi-outdoor plants, it does not necessarily offset increased equipment costs. An outdoor type of plant may be competitive with an indoor type at a site having low maximum tailwater and where the number of generating units to be provided is sufficient to minimize increased crane costs. The structural economy of a semi-outdoor plant is marginal since the only saving is in wall height, while the roof, which is actually the working deck, must generally sustain higher live loads. It is emphasized, however, that selection of type, for any given site, can only be made after a thorough study.

2-7. General Arrangement of Powerhouse

In general, a powerhouse may be divided into three areas: the main powerhouse structure, housing the generating units and having either separate or combined generator and turbine room, erection bay, and service areas.

a. Main powerhouse structure. The generator room is the main feature of the powerhouse about which other areas are grouped. It is divided into bays or blocks with one generating unit normally located in each block. The width (upstream-downstream dimensions) of the generator room for the indoor type should provide for a passageway or aisle with a minimum width of 10 feet between the generators and one powerhouse wall. The height of the generator room is governed by the maximum clearance height required for dismantling and/or moving major items of equipment, such as parts of generators and turbines; location of the crane rails due to erection bay requirements; the crane clearance requirements; and the type of roof framing. All clearances should be adequate to provide convenient working space

but should not be excessive. The elevation of the turbine room floor should be established so as to provide a minimum requirement of 3 feet of concrete over a steel spiral case, or a minimum roof thickness of 4 feet for a semi-spiral concrete case. In establishing the distance between the generator and turbine room floors, if they are not combined, the size of equipment to be handled in the turbine room, the head room between platforms in the turbine pit, and the generator room floor construction should be considered.

b. Erection bay. In general, the erection bay should be located at the end of the generator room, preferably at the same floor elevation and with a length equal to at least one generator bay. The above length should be increased sufficiently to provide adequate working room if railroad access is provided into the erection bay at right angles to the axis of the powerhouse; however, no additional space should be required if the access railroad enters from the end of the powerhouse. In cases where the elevation of the crane rail would be dependent on the requirement that a transformer with bushings in place be brought under the crane girder, consideration should be given to the possible advantages of revising the layout to permit bringing the transformer in at the end of the structure, at the end of the generator room, if the generator room is at a lower elevation than the erection bay, or removing bushings before moving transformer into powerhouse. If the height required for untying a transformer appears to be the controlling dimension, a study should be made of the economy of installing a hatchway and pit in the erection bay floor to provide the required height.

c. Service area. Service areas include offices, control and testing rooms, storage rooms, maintenance shop, auxiliary equipment rooms, and other rooms for special uses. For plants located at the toes of gravity dams, the space available between the generator room and the face of the dam is a logical location for most of the features enumerated above. However, in all cases an economic study, which should include the cost of any added length of penstock required, should be made before deciding to increase the space between the dam and powerhouse to accommodate these features. The offices are frequently located on upper floors, and the control room and other service rooms on lower floors. The most advantageous location for the maintenance shop is usually at the generator room floor level.

d. Space allocations. Space should be provided for some or all of the following features and uses, as required:

(1) Public areas: main public entrance, reception area, public rest rooms, exhibits, and elevator.

(2) Employee areas: employee entrance, equipment entrance, offices, office storage, rest rooms for office use, control room, rest rooms for control room operators, kitchen for control room operators, repair and test room for instruments, main generator rooms, main turbine rooms, station service or fish water units area, erection and/or service areas.

(3) Shops: machine, electrical, electronic, pipe, welding, sheet metal, carpenter, and paint with spray booth.

(4) Storage and miscellaneous areas: storage battery and battery charger rooms, cable galleries, cable spreading room under control room, telephone and carrier current equipment room, oil storage tank room, oil purification room, storage for paints and miscellaneous lubricants, storage rooms, locker rooms with showers and toilet facilities, first aid room, lunch room with kitchen facilities, elevator, heating, ventilation, and air conditioning equipment rooms, and auxiliary equipment rooms.

2-8. Location of Main Power Transformers

The choice of location of the main power transformers is inter-related with the selection of the type and rating of the transformers. The selection of single-phase or 3-phase type of transformers, the method of cooling, and the kVA rating are also directly related to the basic switching provisions selected for the plant, the number and rating of generators associated with each transformer or transformer bank, and the location of the transformers. In order to determine the most suitable and economical installation, including the type, rating, and location of the main power transformers, adequate studies, including comparative estimates of total installed first cost and total annual cost for each scheme studied, should be made during the preliminary design stage along with studies to determine the basic switching arrangement and general arrangement of the powerplant. Locations at which the main power transformers may be placed are: between the powerhouse and dam, on the draft tube deck, in the switchyard, and near the powerhouse but not in the switchyard. From the viewpoint of electrical efficiency, the power connections between the generators and transformers should be as short as practicable. This consideration favors the location of the transformers at or near the powerhouse. In deciding between the upstream or downstream location at the powerhouse, consideration should be given to the location of the switchyard and the

nature of the high-voltage connections between it and the transformers. In some cases the location of the transformers on the draft tube deck may increase the cost of the powerhouse structure. However, if such a location makes possible a direct overhead connection to the switchyard, this feature may more than balance any increased cost of the structure. At small plants and, where the switchyard can be located close to the powerhouse, a transformer location in the switchyard may be economical. Where transformers are located between the powerhouse and dam, special high-voltage cable connections to the switchyard may be required. In selecting the location for the transformers, as well as in planning the general plant arrangement, consideration should be given to the requirements for transporting and unloading the transformers.

2-9. Powerhouse and Switchyard Equipment

The connection between items of equipment in the powerhouse and switchyard will require special study in each individual case. The connections fall into three classes described below:

a. Main power connections. In general, when the main power transformers are located in the switchyard, the main power connections between the powerhouse and switchyard should be carried in an underground tunnel or duct bank. When the transformers are at the powerhouse, consideration should be given to the economy and advantages of overhead connections.

b. Control cables and power supply to switchyard. The number and types of these connections require that they be run underground. For best protection from dampness and for ease of inspection and replacement, a cable tunnel is usually justifiable in major plants. In small plants, the cables are sometimes run in conduits or duct banks from the powerhouse to a distributing point in the switchyard.

c. Oil piping. It is desirable to concentrate oil purification operations and oil storage in the powerhouse. This concentration requires connections between the switchyard and powerhouse for both clean and dirty insulating oil. If a tunnel is required for electrical connections, these pipes can be run in the same tunnel; otherwise, they must be buried underground. If the switchyard is some distance from the powerhouse, a separate oil purification and storage system may be more economical. Oil piping or tanks buried underground must meet local, state, and Federal regulations for environmental protection.

d. Drains. Any drains that may handle a mixture of oil and water should be connected to an oil/water separator.

2-10. Powerhouse Auxiliary Equipment

In planning the general arrangement of the powerhouse, space must be assigned in all of the auxiliary electrical and mechanical equipment that will be required. The location of the auxiliary equipment must also be considered with respect to the location of the main equipment with which it is associated. The following is a list of auxiliary equipment and systems usually required for powerplants. It is not expected that all items listed will be incorporated in all plants. The size, service, and general requirements of the plant will usually determine which items are necessary: water supply systems for raw, treated, and cooling water, unwatering systems, insulating and lubricating oil transfer, storage and purifications systems, compressed air systems, turbine

governing equipment, fire protection, detection and annunciation, heating, ventilating, and air conditioning systems, turbine flow meters, water level transmitters and recorders, elevators, main generator excitation equipment, station service power generating units, station service transformers and switchgear, main unit control boards, station service control boards, storage battery and chargers, inverter, electronic equipment (carrier current microwave), telephone and code call system, maintenance shop equipment, sewage disposal equipment, auxiliary equipment for oil-filled or gas-filled cables, emergency engine-driven generator, incinerator, station drainage system, generator voltage switchgear, metal-enclosed buses, and surge protection equipment, air receivers for draft tube water depressing system, heating, ventilation and air conditioning switchgear, lighting transformers and switchgear, unit auxiliary power centers, electrical shop, transformer oil pumps and heat exchangers (when located remote from the transformers), and generator neutral grounding equipment and switchgear.

Chapter 3 Architectural Requirements

3-1. Exterior Design

a. The importance. Exterior design should be considered throughout the design process. In general, the design should receive most attention once the general arrangement of the powerhouse including floor and crane rail elevations and crane clearances is determined. It should utilize scale, proportion, rhythm, and composition to achieve an aesthetically pleasing structure which fits in with its natural surroundings. In achieving these ends economy is important, and, although decoration and complexity are not to be ruled out, simplicity should be the keynote.

b. Aesthetic appearance. The arrangement and dimensions of the various masses is determined by the physical requirements of the powerhouse components. However, in the design of the ensemble of these masses, the architect should be allowed freedom consistent with an efficient and economical plant layout. In addition, some of the devices that may be used to define and compose the masses and give scale, proportion, and rhythm are changes in texture and materials, emphasis of horizontal pour joints and vertical contraction joints, and placement and sizing of fenestration and openings. The exact size and location of openings should be determined from the standpoint of aesthetics after the structural, mechanical, and functional requirements have been investigated. Windows need not be used, but they may be desirable in order to let in natural light and increase employee morale. When used, their form and location should relate to their function and the aesthetic appearance of the structure. In general, large glass areas in operating portions of the powerhouse should be avoided to minimize blast damage, but small windows high in the powerhouse walls may have value in this respect as blast pressure relief openings.

c. Final selection. Selection of the final powerhouse design should be made after a careful study of at least three designs having basically different exterior treatments. Each proposed design should be carefully developed and perspective drawings prepared. The point of vision for the perspectives should be a point from which the general public will view the structure. The sketches, which are to be used for the selection of exterior treatment, should include all of the adjacent structures and surroundings.

3-2. Exterior Details

Exterior details are discussed in the following subparagraphs.

a. Roofing. Powerhouse roofs may be pitched (gabled, hipped, vaulted, etc.) or flat (pitch not greater than 1 inch per foot nor flatter than 1/2 inch per foot). Pitched roofs are preferred because of lower maintenance costs (flat roofs must be waterproof, whereas pitched roofs need only be watershedding). Parapets that meet current safety codes should be provided at all roof edges. Cants should be provided at the intersection of roof and all vertical surfaces in order to eliminate sharp angles in the roofing. In designing the roofing system, i.e. insulation, roofing, flashing, and expansion joint covers, the most current roofing technology should be utilized. Whenever roofs are exposed to public view from the top of the dam or the abutments, special materials may be used for appearance, e.g. marble chips in place of gravel surfacing.

b. Decks. Exterior concrete decks covering interior spaces should be of watertight construction. Where the deck is covering habitable areas, or areas containing equipment which could be damaged by water, a waterproof membrane with concrete topping shall be added to the structural slab.

c. Walls. Due to structural considerations, e.g. the usual necessity to support crane rails, and the fact that concrete is the main material used in powerhouse construction, concrete is the most commonly used material for the exterior walls of superstructure. However, other systems such as prefabricated insulated aluminum or stainless steel wall panels, concrete masonry, brick, etc. may be used provided an overall economy is effected. Concrete should always be used below maximum powerhouse design tailwater elevation. The finish of the exterior surface of powerhouse superstructures is discussed in paragraph 4-14*b*. All details for concrete construction such as joints, rustication, V-grooves, corner chamfers, and fillets should be studied and considered in the architectural design. The V-grooves, where required should not be less than 1 inch across the face and 1/2-inch deep. The angle at the bottom of the V-grooves should be about 90 degrees. All contraction joints in the substructure should be continued through the superstructure and considered in the design, regardless of the material used for the walls. Wall panels should not be laid continuously across such joints. Flashings or waterstops should be used in all exterior vertical contraction joints.

Flashing, jamb closures, corner plates, parapet and eave closure plates for insulated metal walls should be of the same material and the same gage as specified for exterior wall plates.

d. Entrances. Entrances should conform to OSHA requirements. Not only should all entrances be located for proper and efficient operation of the plant, but they also should be placed to obtain a pleasing exterior architectural design. The dimensions of the door openings should be governed by the required use and should not be sized for the exterior appearance alone. Doors required for proper operation of the plant should not be of monumental type, but should give the impression that the doors are for plant operation. The public entrance may be more decorative than other plant doorways and, if desired, may be massive when used as a design feature. Doors of structural glass or of glass and aluminum are recommended for public entrances. Large doors should either be hinged at the sides and supported at the top by a trolley for folding-door operation or should be of the motor-operated, vertical-lift or overhead rolling doors type where clearances are adequate and where considered desirable from an operation standpoint. A pilot door should be provided in any large door, when a small entrance door is not nearby.

e. Fenestration. The openings in the exterior walls of the generator room should be confined to the necessary access doors and to ventilation louvers or small windows above the crane rails. All sash, trim, or exposed exterior metal should be of aluminum or corrosion-resisting metal requiring no painting and, in general, should be detailed for standard manufactured products. The use of specially designed sash and trim should be limited to the public entrance. When the main transformers are to be located close to the powerhouse wall on either the upstream or downstream decks, no windows should be planned in the adjacent portion of the wall. Where possible, the use of windows in office areas and lunch rooms is encouraged. They should be operable for ventilation and easy to clean such as tilt-turn windows. Glazing should generally be insulating glass. Full-length glass doors and sidelights should be glazed with tempered glass. In certain cases, where the admission of light is desired but a clear view is not necessary, the use of double skin insulating plastics may be considered. Wire glass and glass block will give security and light blast protection. Glass block may be used as a design element.

f. Draft tube deck. The draft tube deck should be wide enough to provide safe clearances for operating the

gantry crane, painting and repairing the crane and gates, and removing and reinstalling the gratings. Hose bibbs of the nonfreeze type should be recessed in the wall of the powerhouse. A concrete parapet, with or without a pipe handrailing on top, should be provided on the downstream side of the deck and should have an overall height above the deck of three and one-half feet or as required by current safety codes. The design of the lighting system for the draft tube deck may include provisions in the parapet to accommodate lighting fixtures. Drainage lines from the deck should be as short and direct as possible, but the outlets should be concealed. To avoid a tripping hazard, crane rails should be installed in blockouts with the top of the rail approximately flush with the deck. Blockout should be partially filled with non-shrink grout, and the top remainder of the recess filled with a two-component, cold-applied, self leveling type sealant. The thickness of the sealant is determined by the compressive space required for the crane wheel flange depth.

g. Stairs and railings. Exterior stairs should be provided with safety treads made of a material that will not rust or require painting and may consist of abrasive material troweled into the finish or abrasive strips embedded in the tread and nosing. Handrailings should be made of concrete, concrete and metal, or metal only. The metal railings should be treated or a material specified so that maintenance painting will not be required. All railings should be designed to comply with the most current safety codes.

h. Skylights. Skylights can present leakage and maintenance problems and should therefore be limited to use in visitor's areas where a special effect is desired. The framing should be aluminum or corrosion-resisting metal. They should be glazed with insulating glass or double-skin insulating plastic. Insulating glass should consist of a top layer of tempered glass and a bottom layer of laminated safety glass or as required by current local codes.

3-3. Interior Design

Interior details are discussed in the following subparagraphs.

a. Visitor's facilities. All attended power plants will normally be provided with limited space for the visiting public. This space should be kept to the minimum required for the estimated attendance. The items mentioned in the following paragraphs should be considered in planning the public spaces for all power plants. The public entrance for small plants may be combined with

the employee entrance, and when so located it should be properly marked as a visitors' entrance. For larger plants, a separate, prominently located visitors' entrance should be provided. The entrance to the visitors' area should be as direct as possible from the avenue of public approach and should be accessible to handicapped visitors. An entry vestibule is desirable, but not essential. The design of the visitors' area should take into consideration provisions for exhibits, and location of drinking fountains, public toilet rooms, and vertical transportation, e.g. elevators for handicapped access. The visitors' areas should be arranged so that they are isolated from all other parts of the plant except for access through locked doors. The room finishes should be attractive, serviceable, and easily maintained. Some of the materials that should be considered for use are terrazzo, ceramic and quarry tiles, plaster coated with a durable enamel paint, acoustical tile ceilings, etc. Each material should be evaluated on the basis of cost, appearance, durability, and ease of maintenance.

b. Control room facilities. The control room space should be planned for the ultimate development of the powerhouse, regardless of the number of units installed initially. The control room should be planned for convenience in operation and the equipment should be spaced to permit easy circulation, easy access to equipment for repair or replacement, and convenient installation of future equipment. A minimum space of 4 feet should be provided between the switchboards and the walls and between switchboards and other major equipment. Doors or removable panels of adequate size should be provided to accommodate the installation of future switchboard panels. Items such as specially designed operator's desks, control consoles, and key and map cases should be considered in planning the control room.

(1) Rooms which should be provided as auxiliaries of the control room at attended power plants usually include a small kitchen, a toilet, a supplyroom, and a clothes closet. These rooms should be directly accessible to the operators without the use of hallways. The toilet room should contain one water closet and a lavatory complete with necessary accessories. The supply room should include shelving for storage of forms and supplies used by the operators. The clothes closet should have a hat shelf and clothes rod.

(2) The control room floor may be carpeted or have resilient floor covering such as rubber or vinyl-plastic tile. The walls should be smooth, e.g. plaster or sheet-rock, and painted. The ceiling should be suspended

acoustical tile. Special thought should be given to sound control. Sound-absorbing wall panels should be considered. They should be covered with perforated vinyl for ease of maintenance. Windows between the control room and the main powerhouse area should have insulated glazing and sound absorbing insulation in the frame. The control room will usually have special lighting, carefully placed to prevent annoying reflections on the instrument panel glass.

(3) The toilet should have ceramic tile floor and walls and painted plaster ceiling. The other small rooms should have the same floor covering as the control room and should have painted plaster or gypsum wallboard walls and ceilings. Cove bases of rubber, vinyl, or ceramic tile should be used in all of the rooms. In some plants, an instrument and relay testing room and a telephone and electronic equipment room may be required. Such rooms should be located near the control room. A photographic darkroom should also be provided in this area for plants using oscillographic equipment. In the darkroom, there should be a stainless steel sink and drainboard for developing and washing films, storage space for developing apparatus, and a storage cabinet for films. A workbench with the necessary electrical connections and a storage cabinet or closet should be provided in the instrument and relay test room. The telephone and electronic equipment room should also be located convenient to the control room and preferably should be above maximum design tailwater elevation. This room must be kept clean and free from dust and should be located with this in mind.

c. Generator room and auxiliary spaces. The arrangement of the rooms and spaces that will house the electrical and mechanical equipment essential to the operation and maintenance of the plant should be determined on the basis of an over-all study of the requirements of the functions involved. A workable, convenient, economical arrangement should be developed that is structurally and architecturally sound.

(1) The criteria governing the layout of the generator room are given in paragraph 2-7a. A sufficient amount may be added to the minimum clearances required for installation, operation, repair, and overhaul to secure reasonably convenient space for carrying out these functions. It is not intended that clearances and operating spaces should be arbitrarily overdesigned, but reasonable operating convenience should not be sacrificed in order to secure minimum cost. The space allotment for the erection bay is discussed in paragraph 2-7b. As the erection bay is merely an extension of the generator

room, the entire space should be treated architecturally as one room. In general, the treatment should be as simple as possible. The floor finish selected should be the economic one for the plant under consideration. It should be one that will not dust, will resist damage during minor repairs to equipment, and can be satisfactorily repaired if accidentally damaged. Also, a finish shall be used that will clean easily and will not deteriorate with frequent cleaning. Terrazzo is usually justified due to its extreme durability, ease of maintenance, and attractive appearance. In certain cases a wainscot of ceramic tile or some other material may be justified, however, concrete walls are usually sufficient. Concrete walls and ceiling should be painted or sealed to prevent dusting. Special consideration should be given to the design of the roof framing, as well as any ventilation duct work and piping that must be carried under the roof, in order to obtain as pleasing an appearance as possible.

(2) The allotment of space for a maintenance shop should be determined from a layout of the equipment considered necessary to maintain the plant. This room should be located on the generator room floor level and should adjoin the erection bay if possible. The ceiling height should be adequate to provide for the use of a small overhead crane for handling equipment being repaired. The capacity of the crane must be determined by the weight of equipment to be handled. Where partitions form a wall of this room, the partition should be of concrete or concrete masonry units. Partition and walls may be painted or sealed.

(3) The general arrangement of auxiliary equipment is usually determined in making the basic plant layout. An economical and convenient arrangement of this equipment may be achieved only by thorough study of all the requirements and by careful coordination of the various systems. The auxiliary equipment and services for which space will usually be required are listed under paragraph 2-10.

(a) The spaces allotted for the electrical shop, for sewage disposal, and for oil purification and storage should be enclosed; but it is not essential that separate rooms be provided for all of the other functions. In many cases, open bays housing several functions will be practicable, and such an arrangement will usually be more economical than a layout that provides separate rooms for each function.

(b) Storage battery and charging rooms shall be designed to conform to Corps, OSHA, and NEC safety codes. Storage battery and battery charging rooms

preferably should be located above high tailwater elevation and should be adequately ventilated. A sink constructed of acid-resistant material should be provided in the battery room. Drainage from the sink and floor drains should flow to an acid neutralization tank, then discharge to the sewer system. All piping to the neutralization tank and floor drain, including the drains themselves, should be acid resistant. The walls and floor of this room should be painted with an acid-resistant enamel. The ceiling may be painted to improve lighting conditions if desired. Access to the rooms should be adequate for easy installation and replacement of equipment.

(c) The floors of the oil purification and storage rooms should be trowel-finished concrete, painted with oil-resistant paint or sealed. The lower 6 feet of the walls should have an oil-resistant painted dado, with the walls above the dado and the ceiling unpainted. All other rooms should receive no special finishes.

d. Personnel facilities. Employee facilities required for efficient plant operation should be based upon approved design memorandum on plant staffing. These facilities usually include the offices, toilet, shower, locker rooms, employees' lunchroom, stairways, corridors, and elevator. In the larger plants, it is usually necessary to provide a conference room suitable for employee management meetings.

(1) The requirements for office space will probably vary with each plant, but at all attended powerplants it is recommended that offices be provided for the plant superintendent and for general clerical space. The requirements of each plant should govern the allotment of additional space for offices, and the expected operating organization must be determined before the planning can be completed. A fireproof vault, file and record rooms, storage closets, and clothes closets should be provided as required and should be conveniently located with respect to the offices. Plants should provide toilet rooms for both male and female employees in the office area. The minimum requirements for the men's toilet should be one water closet, one urinal, and one lavatory; and for the women's toilet, the requirements should be one water closet and one lavatory, but in all cases shall meet the requirements of local codes. Floors should be of rubber or vinyl-plastic tile with a light but serviceable color with a nondirectional pattern that will hide scuff marks and a dark cove base. Dark, patterned carpeting with rubber or vinyl cove base may be considered. Plastered masonry walls, gypsum wallboard, or metal partitions should be painted with interior enamel.

Ceilings should be suspended acoustical tile. The closets and storage rooms should be finished the same as the offices. The toilet rooms should have ceramic tile floors, tile cove bases, and glazed tile wainscot with painted plastered or concrete masonry walls above. The stalls in toilet rooms should be metal with factory-applied enamel or other durable coating.

(2) A minimum width of 5 feet should be used for all office corridors and a minimum of 6 feet for all corridors in work areas where corridors may be used for handling equipment. In planning corridors and openings, consideration should always be given to the desirability (and in some cases the necessity) of bringing bulky equipment into the plant and installing it intact. The corridors on the office floor levels will normally be finished similarly to the offices. Floors of corridors on the other levels should be trowel-finished concrete with hardener added. Where floors are likely to remain wet a light brush finish after troweling should be specified to prevent slipping. Painted concrete floors should be avoided because of the maintenance involved. Partitions should be concrete or concrete masonry as desired. Unfinished concrete ceilings should be used and may be painted or not as required to improve lighting.

(3) Stairways, aside from entrance steps or stairs, may be classed under three general types: office stairs, work area stairs, and limited-use stairs or ladders. The office stairways should have concrete or masonry walls, painted to match the finish in the adjacent areas; soffits or ceilings may be painted or left unfinished. The finish as described above should extend to the floor levels below and above the office floor. The office stairs should be of the pan type, steel-supported; with concrete safety treads with safety nosings and metal risers. Painted metal, galvanized pipe or extruded aluminum handrails may be used for these areas. Work area stairs should be similar to office stairs or concrete with safety tread nosings, and the walls and ceilings should be unfinished concrete. Limited-use stairs and ladders, which provide access to places requiring no regular service, may be of concrete or steel of simple design and provided with adequate protection as required by current safety codes.

(4) Both male and female personnel of the plant should be provided with adjoining locker, shower, and toilet rooms, located near the maintenance shop and erection bay. In large plants, additional toilet rooms should be provided toward the far end of the plant. The locker rooms should have forced ventilation and should contain benches and built-in type metal lockers. The

shower rooms should have gang-type showers for men with one shower head for each ten men to be accommodated per day, and individual shower and drying stalls for women with one shower for each ten women to be accommodated per day. In general, an increasing percentage of female workers should be planned for. The toilet rooms adjoining the locker and shower room should have one water closet, one lavatory and for men, one urinal for each ten personnel to be accommodated per day. The additional toilet rooms shall be limited to one water closet, one lavatory and for men, one urinal. In some cases unisex toilet rooms may be used. A drinking fountain should be located in the corridor adjacent to the area. Walls should be concrete, masonry or gypsum wall board on steel studs. Shower and toilet room walls should have a standard height, glazed tile wainscot, except in the showers, where it should extend to the height of the shower head. Ceilings and concrete portion of the walls of the shower room subject to steam vapors should be given a prime coat of primer-sealer (conforming to the latest edition of Federal Specification TT-P-56), one coat of enamel undercoat (conforming to the latest edition of Federal Specification (TT-E-543) followed by one coat of gloss enamel (conforming to the latest edition of Federal Specification TT-E-506). Concrete masonry walls should receive one coat of concrete emulsion filler prior to the above treatment. A janitor's closet should be provided and should have a service sink and shelves for supplies. The walls of the janitor's closet shall be painted gypsum wall board or unpainted concrete or masonry. The floor shall be trowel-finished concrete with no base.

(5) A lunch and break room should be provided. It should include adequate counter space and storage cabinets and a range top with ventilation. It should provide space for a refrigerator, microwave ovens, and vending machines. There should be adequate electrical outlets for coffee pots, microwave ovens, vending machines, etc. It should have sufficient room to accommodate anticipated plant personnel. Finishes should consist of rubber or vinyl plastic resilient flooring with cove base, painted walls, and suspended acoustical tile ceiling. Insofar as practical, the lunch room should be located so as to minimize the noise and vibration of the powerplant. The use of sound absorbing wall panels covered with perforated vinyl should be considered. Sound dampers may have to be used for the lunch room HVAC system. Unnecessary wall penetrations should be avoided. If practical, consideration should be given to locating the lunch room at a level where windows to the outside can be provided. This is highly desirable considering the indoor nature of the work.

(6) A first-aid room should be planned adjacent to the control room, if practicable, or otherwise on either the office or locker floor level. This room should contain a first-aid cabinet, a cot, and a lavatory and should have rubber or vinyl-plastic tile floor and cove base, painted walls, and ceiling. The door should be wide enough to accommodate a stretcher.

(7) A powerhouse having more than three floor levels should be provided with one or more elevators designed in conformance with the ANSI Safety Code for Elevators and Dumbwaiters, Escalators and Moving Walks, A 17.1. The location should be established to enable omission of a penthouse above the roof of the structure if possible and to reduce corridor travel to a minimum. The elevator should be a passenger type having minimum inside dimensions of five feet by seven feet, and a minimum capacity in conformance with ANSI A 17.1. Car speed should not be less than 200 feet per minute and controls should be of the pushbutton, automatic selective, collective type. Car and hoistway doors should be of the horizontal sliding type equipped with automatic, two-speed power operators. In large powerhouses, a freight elevator may also be provided.

3-4. Interior Details

In order to obtain reasonable uniformity and to establish a high standard of quality, certain interior details are described in the following paragraphs. However, these details are not mandatory. The designer should use his knowledge of equipment and materials to achieve simplicity and first-cost economy consistent with utility, safety, aesthetics, and low maintenance costs.

a. Floor and wall finishes. All floors should be designed for serviceability and appearance and should adjoin all walls with a cove base if practical. These cove bases should be of concrete, ceramic or quarry tile, or rubber or vinyl-plastic material. Where wet walls and floors may be expected because of seepage, condensation, and similar conditions, gutters should be provided around the room at the walls. Cove bases are not required where gutters are used. Floors in rooms where oil or water is stored, processed, or handled should be adequately drained. A floor slope of 1/8-inch per foot is recommended where floor drains are installed. Curbs should not be provided at doors in these rooms except as a last resort. The floors should be recessed below adjacent floor whenever feasible. Steps should not be located at the immediate entrance. A platform or a ramp with nonslip finish and maximum slope of 1 in 12 should be provided.

b. Acoustical tile ceiling. Where flat acoustical ceilings are required, acoustical tile of suitable design may be supported on steel supports.

c. Door trim. All trim for doors throughout the plant should be of metal. It is recommended that bucks be used for mounting all trim. Poured-in-place, integral jambs, and trim are not desired except in areas where structural shapes are used as the finish trim.

d. Plumbing fixtures. Maintenance of the toilet rooms of the plant will be made easier if the floor area is clear of fixture mountings. For this reason, wall-hung urinals, water-closets, and lavatories should be used throughout the plant. Wall-hung, foot-operated flush valves should be furnished for water closets and urinals. Unit coolers should be provided for drinking water, positioned in such manner as not to unduly restrict passage through corridors. Because of possible damage due to leaks and to facilitate access for repairs, plumbing fixtures, water supply, or drain piping should not be located above the control room or directly over electrical switchgear and similar equipment.

3-5. Schedule of Finishes

The finishes of some of the rooms in the plant are described above in detail. The finishes for all rooms in a plant should be shown in the form of schedules to be included in the contract drawings. The schedules should define the "finish" and "color" of the various components of each room, such as floors, walls, ceilings, trim, doors, and equipment and should indicate the number and type of prime and finish coats of paint required. Paint colors should be specified by the numbering system of the paint color chips shown in Federal Standard No. 595, "Colors".

3-6. Painting

The painting requirements for both the above and below water level portions of the powerhouse are adequately covered, both as to the surface preparation and paint systems to be specified in Guide Specification CW-09940, provisions of which should be followed in preparing the painting portion of the Schedule of Finishes.

a. Special formulations. The special formulations listed in the above guide specification, or Standard Federal Specifications should be used to procure the paint ingredients required in lieu of reference to a specific manufacturer's product.

b. Aesthetic goals. Paint used to achieve aesthetic goals and super-graphics used to convey information and directions are considered appropriate in areas open to the public.

c. Reasons for painting. With the few exceptions already listed, painting should not be used for decorative purposes but should be confined to preventing corrosion of the surfaces requiring protection, to improving lighting efficiency, and to stopping dusting of concrete. When painting is required for concrete walls, the concrete in area visible to the public should have a sack-rubbed finish before applying the paint.

d. Requirements. Painting requirements should be covered by general provisions in the specifications and detailed information shown on the Schedule of Finishes. Some painting requirements may need to be indicated on the details.

3-7. Design Memorandum

The architectural design of the powerhouse should be thoroughly discussed in a design memorandum. General and specific consideration that influenced the exterior design and type of construction should be given. The reasons for designing a windowless plant or for using windows and also the reasons for using various materials such as precast concrete panels, concrete poured monolithically, prefabricated aluminum or stainless steel wall panels for the exterior finishes of the powerhouse should be stated. The method of determining the amount of space allotted for public use and for offices should be explained.

3-8. Drawings

The architectural drawings required for the construction of the powerplant should include the layout of grounds and access roads, exterior and interior elevations of the powerhouse, cross sections through the powerhouse showing all types of construction and floor elevations, detail elevations of all tile work and special interior

treatments, detail sections of stairs, stair and handrail details, window and door schedules and details, plans of all floors and roofs, detail plans of special areas such as public reception room, details of special decorative items, details of dado and tile finishes, details of roofing and flashings, and any other architectural details that will be needed for the construction of the powerhouse. A rectangular system of column reference lines should be established and, in general, all dimensions should be tied to these reference lines.

a. General layout. The general layout should be drawn at such a scale as to require only one sheet and should show means of access to the plant, public and employee parking facilities, grading, drainage, lighting, and landscaping. Details of architectural features of the layout, such as floodlighting arrangements and landscaping, should be shown at a larger scale on other drawings.

b. Elevations. The exterior elevations of the powerhouse should be made at a scale that will allow the full length of the powerhouse to be shown on a standard size sheet. These elevations should show all roof and floor elevations, finish grade elevations, all windows, doors, or other openings, V-rustications, surface treatments and special decorations and should make reference to the proper drawings for details. Interior elevations of powerhouse walls may usually be shown adequately on the cross sections. All tile wainscots should be drawn in elevation at not less than a 1/4-inch scale and should show the vertical and horizontal courses of tile and should give dimensions of the tile and of wall openings. All wainscots, floors, and door openings should be laid out, using the 4-inch modular system as proposed by the American Standards Association.

c. Plans. Construction drawings required for the construction of the powerplant shall be in accordance with specific requirements of Paragraph 7c of CE-4000, "Lump-sum Contract for Engineer Services for Design of Hydroelectric Power Plant."

Chapter 4 Structural Requirements

4-1. Design Stresses

Allowable stresses will depend on the materials involved, the conditions of loading, and severity of exposure.

a. Allowable stresses. Structural steel and welded joints should be designed in accordance with the allowable stresses outlined in the latest version of the AISC construction manual. Welding details should be as outlined by the latest version of AWS D1.1 "Structural Welding Code-Steel." Gates, Bulkheads, Trashracks, and associated guides should be designed using the allowable stresses outlined in EM 1110-1-2102. Steel and aluminum/switchyard structure should be as designed with the loading and allowable stresses contained in NEMA publication SG-6 "Power Switching Equipment," part 36.

b. Concrete structures. Concrete structures loaded hydraulically should be designed in accordance with the procedures outlined in EM 1110-2-2104 "Strength Design for Reinforced Concrete Hydraulic Structures." Those portions of a powerhouse that will not have water loading, such as the superstructure, may be designed in accordance with the latest version of ACI 318 "Building Code Requirements for Reinforced Concrete."

4-2. Design Loads

a. General considerations. The structures should be designed to sustain the maximum dead, live, hydrostatic, wind, or earthquake loads which may be imposed upon them. Where only partial installation is to be made under the initial construction program, consideration should be given to the temporary loading conditions as well as those anticipated for the completed structures. The stability of all powerhouse monoliths should be investigated for all stages of construction; and loads that may be imposed or absent during the construction period should be accounted for in the design memoranda.

b. Dead loads. Dead loads to be considered in the design consist of the weight of the structure itself, including the walls, floors, partitions, roofs, and all other permanent construction and fixed equipment. The approximate unit weights of materials commonly used in construction can be found in the AISC Manual. For those materials not included, refer to ASCE (1990). A

check should be made of the actual weights where a variation might affect the adequacy of the design, or in cases where the construction may vary from normal practice.

c. Live loads. In general, floors are designed for an assumed uniform load per square foot of floor area. However, the floors should be investigated for the effects of any concentrated load, minus the uniform load, over the area occupied. Equipment loads should take into account installation, erection, and maintenance conditions as well as impact and vibration after installation. In most cases, it will be necessary to proceed with the design on the basis of estimated loads and loaded areas until such time as the actual data are available from the manufacturers. All live loads used in design should be recorded with notations as to whether the loads are actual or assumed. The weights of turbines and generators of Corps of Engineers hydroelectric power projects are tabulated in Appendix B1. However, weights will vary considerably for units of the same capacity. Estimates of the weights of the machines should always be requested from the manufacturers for preliminary use in the design. Assumed loads should be checked later against actual loads, and, where differences are appreciable, the necessary modifications in the design should be made.

(1) The live loads shown in Table 4-1 are recommended for the design of slabs, beams, girders, and columns in the area indicated. These loads may be modified, if necessary, to suit the conditions on individual projects, but will ordinarily be considered minimum design loads. These loads may be reduced 20 percent for the design of a girder, truss, column, or footing supporting more than 300 square feet of slab, except that for generator room and erection floors this reduction will be allowed only where the member under consideration supports more than 500 square feet of slab. This differs from ASCE (1990) recommendations for live load reduction because of the loadings historically required in powerhouse floor slabs.

(2) Draft tube decks, gantry decks, and erection bays are often made accessible to trucks and Mobile Cranes, the wheel loads of which may produce stresses greater than those caused by the uniform live load. Under these conditions, the loading used for design should include the weight of the heaviest piece of equipment, such as a complete transformer including oil plus the weight of the truck or crane. Stresses should be computed in accordance with AASHTO "Standard Specifications of Highway Bridges." As a safety measure it would be

Table 4-1
Minimum Uniformly Distributed Live Loads

Element	lb/sq ft
Roofs	50
Stairways	100
Floors:	
Offices	100
Corridors	100
Reception rooms	100
Toilets and locker rooms	100
Equipment and storage rooms	200
Control room	200
Spreading room	150
Generator room	*500
Turbine room	1,000
Erection floor	1,000
Maintenance shop	300
Pump rooms and oil purification rooms	200
Gantry deck (outdoor powerhouse)	300 or H 20
Transformer deck	300
Intake deck--general	300 or H 20
Intake deck--heavy lift areas	1,000
Powerhouse access	300 or H 20
Draft tube deck	300 or H 20

*300/lb/sq ft should be used for mezzanine floors and 1,000 lb/sq ft for areas which may be used for storage or erection of generator or turbine parts

advisable to post the load limit in all cases where such a load is used in design. Where mobile cranes are in use, the design should include outrigger loads. Where the powerhouse monoliths include the headgate structure and intake deck, moving concentrated loads such as mobile cranes and trucks handling equipment parts and transformers should be considered in the design of the deck and supporting structure. In case the deck carries a highway, it should be designed for standard highway loading also.

(3) Impact factors for vehicle wheel loads are given in AASHTO "Standard Specifications for Highway Bridges." Impact factors for crane wheel loads on runways are given in paragraph 4c(9).

(4) Wind loading should be applied to the structure as outlined in ASCE (1990). Members subject to stresses produced by a combination of wind and other loads listed under group II in EM 1110-2-2105 should be proportioned on the basis of increased allowable stresses. For concrete structures, ACI 318 and EM 1110-2-2104 provide appropriate load factors to be used for wind loading. The design of switchyard and take-off structures

for wind is covered in the reference cited in paragraphs 4-2d and 4-15.

(5) Construction loads should be carefully considered to determine if provision should be made in the design of these temporary loads or whether false work or temporary bracing will suffice. It will be noted that construction loads are classified as Group II loading in EM 1110-2-2105, and should have the applicable load factor combinations for concrete structures.

(6) The possibility of seismic activity should be considered and appropriate forces included in the design. The structural analysis for seismic loading consists of two parts: The traditional overturning and sliding stability analysis using an appropriate seismic coefficient, and a dynamic internal stress analysis, using either site dependent earthquake ground motions or a static seismic coefficient. The use of the seismic coefficient should be limited to sites where the peak ground acceleration for the maximum credible earthquake is less than 0.2 g. Where a dynamic analysis is involved the powerhouse should be investigated for both the maximum credible earthquake and the operating basic earthquake. Earthquake motions should be picked by procedures outlined in ETL 1110-2-301 "Interim Procedures for Specifying Earthquake Motions." General guidance for seismic design and analysis is found in ER 1110-2-1806 "Earthquake Design and Analysis for Corps of Engineers Projects." Specific criteria for powerhouses should be as outlined in ETL 1110-2-303 "Earthquake Analysis and Design of Concrete Gravity Dams." This reference should be followed closely when the powerhouse intake forms a part of the dam. Site-dependent earthquake time histories or response spectra should be carefully chosen through geological and seismological investigation of the powerhouse site.

(7) All loads resulting from headwater and from tailwater should be accounted for. Since it is sometimes impracticable to protect the powerhouse against flooding at maximum tailwater elevation, a level should be selected above which flooding and equalization of interior and exterior water loads will occur. This elevation should be determined after careful consideration of all factors involved, particularly the cost of initial construction and of rehabilitation in relation to flood levels and frequencies. The structures should be designed to withstand tailwater pressures up to the chosen level and positive provisions should be incorporated in the structure to permit rapid flooding and equalization of pressures after

the tailwater rises above this level. Provisions should also be made for rapid draining of the powerhouse when the tailwater drops. A maximum tailwater elevation (below that selected for flooding the entire powerhouse) should also be chosen for unwatered draft tubes and provisions for automatic flooding of the water passages when that level is exceeded should be considered. It is nearly always advisable to reduce the uplift pressures on the draft-tube floor by means of a drainage system. When "floating" or relatively flexible floor slabs are used, they are not considered in the stability analysis, either as contributing weight or resisting uplift. When the floor slabs must take part of the foundation load, as is sometimes the case when the foundation is soil or poor rock, uplift should be assumed and the slab made an integral part of the draft-tube structure.

(8) Snow loading should be applied to the structure as outlined in ASCE (1990) "Minimum Design Loads for Buildings and other Structures." Members subject to stresses produced by snow loading should be proportioned by treating it as a Group 1 loading in EM 1110-2-2105 or, in the case of concrete structures, as a basic live loading.

(9) Wheel loads should be treated as moving live loads in the design of crane runways. Maximum wheel loads should be computed from the dead load of the crane and trolleys plus the rated live load capacity, with the load in position to produce maximum truck reaction at the side of the runway under consideration. Dimensional data, weights, and truck reactions for cranes installed in Corps of Engineers powerhouses are given in EM 1110-2-4203. An impact allowance of 10 percent for cranes over 80-ton capacity, and from 12 percent to 18 percent for smaller cranes, should be added to the static loads. Side thrust at the top of the rail should be taken as 10 percent of the summation of the trolley weight and rated capacity, with three-fourths of this amount distributed equally among the wheels at either side of the runway. This may vary in the case of unequal stiffness of the walls supporting the runway. For instance, if one wall is relatively massive, the entire side thrust may be taken by this wall with little or no thrust taken by the more slender wall. The runway design should provide for longitudinal forces at the top of rail equal to 10 percent of the maximum vertical wheel loads. Crane stops should be designed to safely withstand the impact of the crane traveling at full speed with power off. Only the dead weight of the crane will be considered and the resulting longitudinal forces should be provided for in the design of the crane runway.

d. Load on switchyard structures. Switchyard structures should be designed for line pull, equipment load, dead load, wind load, snow load, and ice load in accordance with the requirements of the NEMA Publication SG-6-Power Switching Equipment. Take off tower line loading should conform to ANSI Standard C2, National Electrical Safety Code, Section 25, and shall include applicable combinations of dead load, and line tension due to wind, ice and temperature changes.

4-3. Stability Analysis

a. Outline of investigation. A stability analysis should be made for each monolith of the powerhouse and all critical levels should be investigated for the most severe combination of horizontal and vertical forces. In the case of a monolith in which the power unit will not be installed with the initial construction, the stability should be investigated for the interim as well as the final condition. Analysis should be made for the applicable cases indicated below and for any other combinations of conditions which might prove critical. Cases S-1, S-2, S-3, and S-4, below are applicable when the powerhouse is separated from the dam, and Cases M-1, M-2, M-3, and M-4 are applicable when the powerhouse and headworks form a part of the dam.

(1) Applicable when powerhouse is separated from dam.

(a) Case S-1: head gates open--headwater at top of flood-control pool, hydraulic thrusts, minimum tailwater, spiral case full, draft tube full, uplift, and wind or earthquake.

(b) Case S-2: head gates open, tailwater at powerhouse flooding level, spiral case full, draft tube full, uplift, and wind or earthquake.

(c) Case S-3: head gates closed, tailwater at draft-tube flooding level, spiral case empty, draft tube empty, uplift, and wind or earthquake.

(d) Case S-4 (Construction): no tailwater, and no uplift.

(2) Applicable when powerhouse and headworks, form part of dam.

(a) Case M-1: head gates closed, headwater at top of flood-control pool, minimum tailwater (ice pressure (if

applicable)), draft tube and spiral case open to tailwater (uplift), and wind on upstream side or earthquake.

(b) Case M-2: head gates open, headwater at maximum flood level, tailwater at powerhouse flooding level, spiral case full, draft tube full (uplift), and wind on upstream side or earthquake.

(c) Case M-3: head gates closed, headwater at top of flood-control pool, tailwater at draft-tube flooding level, spiral case empty, draft tube empty, uplift, and wind on upstream side or earthquake.

(d) Case M-4 (Construction): no headwater, no tailwater, no uplift, and wind or earthquake.

(3) In some cases, the maximum overturning moment will occur when tailwater is at some intermediate level between minimum and maximum.

(4) In analyzing monoliths containing draft tubes, the floor of the draft tube should not usually be considered as part of the active base area since it is generally designed to take neither uplift nor foundation pressure. (See paragraph 4-2c(7)).

(5) Monoliths should also be checked for lateral stability under applicable conditions, and the possibility of flotation at high tailwater levels should be borne in mind.

b. Vertical forces. The vertical forces that should be considered in the stability analysis are the dead weight of the structure, fixed equipment weights, supported weights of earth and water, and uplift. The weights of movable equipment such as cranes and heavily loaded trucks should be included only where such loads will decrease the factor of safety against overturning.

c. Horizontal forces. The horizontal forces that should be considered are those due to headwater, tailwater, ice, earth, and wind or earthquake pressures. Force due to waves should also be included if the fetch is great enough to cause waves of considerable height. The forces resulting from temperature changes in steel penstocks need not be considered, but the pressure of water in the penstocks should be included as hydraulic thrust resulting from wicket gate closure, depending upon the assumed conditions. The application and intensity of wind pressure or earthquake should be as prescribed in paragraphs 4-2c(4) and 4-2c(6).

d. Uplift assumptions. Effective downstream drainage whether natural or artificial will in general, limit the uplift at the toe of the structure to tailwater. If the powerhouse is separate from the dam, uplift from tailwater should be assumed 100 percent effective on the entire foundation area. If the powerhouse forms part of the dam, uplift assumptions should be the same as those for the dam, as described in EM 1110-2-2200. For those structures founded on soil, uplift should be assumed to vary from headwater to tailwater using the line of seepage method as outlined in EM 1110-2-2502, "Retaining and Floodwalls." For a majority of structures, this method is sufficiently accurate, however there may be special situations where the flow net method is required to evaluate uplift.

e. Base pressures and stability. Ordinarily the maximum base pressures do not govern the design of powerhouse on sound rock. However, regardless of the foundation material, they should always be checked to make sure they do not exceed the safe working values established as a result of the geological or soils investigations. For conditions that include earthquake, the resultant of all forces may fall outside the kern but within the base a sufficient distance so that the allowable foundation pressure is not exceeded. The location of the resultant of all forces, including uplift, acting on the structure should fall within the kern of either a rectangular or irregularly shaped base. In pile foundations, the allowable material, bearing, and tension values for the piles should not be exceeded. If the foundation at the selected site is entirely soil, or is a combination of soil and rock, special consideration should be given to the possibility of unequal settlement. It may be necessary to investigate the shearing strength of the foundation or, in case of a hillside location, to investigate the stability of the structure and foundation together by means of one of the methods discussed in EM 1110-2-1902.

f. Sliding factor. EM 1110-2-2200 contains the criteria and guidance for assessing the sliding stability for dams and related hydraulic structures. Required factor of safety for major concrete structures are 2.0 for normal static loadings and 1.3 for seismic loading conditions. Horizontal earthquake acceleration can be obtained from seismic zone maps and the seismic coefficient method is the most expedient method to use when calculating sliding stability.

4-4. Subgrade Conditions and Treatments

a. Rock foundation. It is very important that the structure rest on sound material, unweathered and unshattered by blasting, in order to develop full resistance to shearing and sliding. The character of some rock foundations is such that disintegration will take place upon short exposure. In these circumstances it will be necessary to preserve, insofar as possible, the natural characteristics of the unexposed foundation material. Disintegration may be prevented either by delaying the excavation of the last foot or two of material until just prior to placing concrete, or by excavating to final grade and immediately applying asphalt or a similar waterproof coating to the exposed surface. Another method is to place a light concrete cover immediately upon exposure, which provides a better surface for workmen and equipment as well as protection for the foundation. An otherwise sound rock foundation may contain seams of clay or other unsuitable materials which must be excavated and filled with concrete, or areas for broken rock which must be consolidated by pressure grouting.

b. Soil foundation. The design of powerhouse foundation on earth is based on the in situ shear and bearing strength of the underlying soil, with consideration being taken of weak seams at deeper depths below the foundation line. Weak materials may require excavation to firmer material or the use of piles as a foundation. A close cooperation between the designer and the foundation and materials engineer must exist even in preliminary design. Factors of safety against sliding should be computed using procedures discussed in paragraph 4-3f.

4-5. Foundation Drainage and Grouting

a. Rock foundation. Provisions should be made for foundation drainage, particularly under the draft-tube floor slabs, to reduce uplift and permit the unwatering of draft tubes. Usually, a network of drains under the draft tubes is all that is required. Holes drilled into the rock connect with these drains, which discharge through weep holes in the slab into the draft tubes. Drain holes should be cleared on a routine basis, perhaps every 5 years, to ensure their functional capability. For unwatering, a drain in each draft tube leads, through a valved connecting pipe, to a header which drains to a sump from which the water is pumped outside the powerhouse. Theoretically, the drill holes in the rock should be deep enough so the hydrostatic uplift (due to maximum tailwater with draft tube unwatered) on a horizontal plane at the bottom of the holes will be more than balanced by the weight of the rock above the plane plus the weight of the draft tube

floor slab. A lesser depth will usually be satisfactory, as the rock may be assumed to "arch" to some extent across the end piers of the draft tube. It is recommended that the drain holes extend to a depth at least equal to one-half the monolith width below the floor slab. Drain holes should be spaced about 12 feet to 15 feet on centers with weep holes in the slab 6 feet to 7-1/2 feet on centers. Where the nature of the rock indicates percolation of such magnitude as to render the unwatering of draft tubes difficult, perimeter grouting, area grouting, or both may be used within the powerhouse foundation area. Care should be taken that this grouting does not interfere with drainage essential to the dam or the powerhouse. If perimeter grouting is used, a system of relief drains near the upstream side of the monoliths is necessary to prevent possible building up of headwater pressure under the structure in case of leakage through or under the upstream grout curtain. Because of the possibility that headwater may enter the area and cause worse unwatering and uplift conditions than would have been the case without curtains, it is desirable to avoid perimeter grouting if possible. For additional information on the purpose, theory, and methods of foundation grouting refer to EM 1110-2-3506.

b. Soil foundations. When powerhouse structures rest on soil, it is necessary to protect the foundation material against scour and piping. The potential for effective drainage and grouting in soil materials is very sensitive to the exact nature of the material. Uplift reduction may be more effective if underlying drainage blankets are used rather than drain holes.

4-6. Substructure Functions and Components

The powerhouse substructure supports the turbines and generators as well as a superstructure for their protection and equipment related to their operation. The substructure also contains the water passages, includes rooms and galleries needed for certain mechanical and electrical equipment and services, and furnishes most of the mass needed for stability. It is usually desirable, where the turbines have steel spiral cases, to provide recesses in the substructure for accommodation of these parts and to design the structure so that concreting operations can continue without interruption during their installation. Access galleries to the draft tube and spiral case should also be provided in the substructure. Except as provided in Table 4-2, substructure concrete should be placed in lifts, generally not more than 5 feet thick. Each lift should be divided into pours by vertical joints as determined by equipment installation needs and as required to minimize shrinkage and temperature cracking.

Table 4-2
Powerhouse Concrete Lift Height Limitations (in feet)

Type of Placement	Temperature-Controlled Concrete		Normal Concrete	
	Watertight	Other	Watertight	Other
Mass or semi-mass areas such as draft tube or spiral case roofs	7-1/2	7-1/2	5	5
Walls and piers over 7 ft thick	7-1/2	10	5	10
Walls and piers 5 ft to 7 ft thick	7-1/2	15	5	10
Walls 18 in. to 5 ft thick	15	20	10	20
Walls less than 18 in. thick heavily reinforced		10		10
Walls less than 18 in. thick moderately reinforced		15		15

4-7. Joints

a. General. The purpose of joints is to facilitate construction, to prevent destructive or unsightly cracks, and to reduce or eliminate the transmission of stresses from one portion of a structure to another.

b. Types of joints. Joints may be classified as expansion, contraction, construction, or control. Selection of the location and type of joint is governed by both architectural and structural requirements. Reinforcing steel or structural steel should not cross expansion or contraction joints, but may be continued across construction and control joints. The functions of the various joints are as follows:

(1) Contraction joints are used to divide the structure into separate monoliths, the principal purpose being to reduce the tendency to crack due to shrinkage resulting from the cooling of the concrete from the maximum temperature. The location and spacing of the transverse contraction joints will be determined by the space required for the unit. Where the powerhouse structure is located immediately downstream or adjacent to the concrete gravity dam, a contraction joint will be provided to separate the dam and powerhouse. In the above case where more than one generating unit is involved, the spacing of the transverse contraction joints of the intake monoliths must be the same as in the powerhouse substructure, although not necessarily on the same alignment. Other detailed criteria for contraction joints as well as the necessary construction joints are given in

EM 1110-2-2000. Ordinarily, no initial opening or treatment of the vertical concrete surfaces at the joint is necessary. However, the longitudinal formed joint between the toe of the dam and the powerhouse (see paragraph 6) should have an initial opening of about 1 inch filled with a suitable premolded compressive-type filler to permit possible movement of the dam without transfer of load to the powerhouse substructure. Contraction joints in the substructure should continue through the superstructure. Offsets in contraction joints are undesirable and should be avoided if possible.

(2) Construction joints are required primarily for the practical purpose of dividing the structure into satisfactory and convenient working units during concrete placement. Also, in large or irregular pours, it is usually desirable to require construction joints in order to minimize the influence of shrinkage on the formation of cracks. Construction joints should be so located and designed that they will not affect the continuity of the structure. Reinforcing steel should be continued across the joint and provisions made to transmit any shear from one side to the other. Horizontal construction joints normally do not require keying, because the roughened surface resulting from water jetting, greencutting, or sand blasting is adequate for transferring shear. This type of joint preparation is not feasible for vertical construction joints where shear keys are usually necessary.

(3) Control joints are adequately described and detailed in EM 1110-2-2000 and in Guide Spec. CW-03301.

c. Criteria for location of construction joints. Construction joints should be located to minimize cracking in the more massive concrete placements. Greater restrictions are necessary where concrete is to be watertight, such as in draft tubes and spiral cases; cracking is caused by heat generated during curing of the concrete and external and internal restraint to attendant volume changes. This type of cracking is minimized by reducing lift heights, using low slump mixes, replacing cement with pozzolan, increasing cure time between lifts, insulating to control the rate of cooling, and reducing the placing temperature of the concrete. Concrete placed under these conditions is termed "temperature-controlled concrete."

(1) For less massive concrete placements, construction joints should be located to facilitate forming and placing of concrete. Lift height is controlled by form, shoring, and bracing design requirements to resist the concrete pressure and dead weight. Reduced lift heights are often necessary when concrete placement is made difficult because of heavy, closely spaced reinforcing, or other physical constraints to placing and compaction equipment.

(2) Basic lift heights (in feet) should not exceed the limitations shown in Table 4-2.

(3) Powerhouse substructures often use a two stage concreting operation where the downstream wall and tailrace structure, and some or all of the spiral case piers are placed in the first stage concrete forming a skeleton structure. The embedded turbine parts, and the sloping floor and roof of unlined concrete spiral cases are cast in the second stage concrete. This arrangement allows early "water-up" of the project, and also allows each unit to be placed "on-line" upon its completion while construction continues in neighboring bays. Keys should be formed in the vertical construction joints of the first stage concrete, and reinforcing dowels provided so the completed structure acts monolithically. Where the vertical joints are subjected to headwater or tailwater pressure, reinforcing should also be adequate to resist the hydrostatic loading created in the joint. When embedding steel lined spiral cases, the lift heights below the center line of the distributor lift heights are limited to 5 feet.

(4) To prevent distortion of the turbine liner concrete should be placed in layers such that there is no more than a one foot height differential of fresh concrete against the liner. The liner is to be continuously sprayed with water during cure of the concrete.

(5) Where main structural slabs frame into walls, it is preferable to locate a horizontal construction joint in the wall at the elevation of the bottom of the slab. The slab is then cast over the prepared wall joint. Keying of mainslabs into walls or piers pose design and construction problems, and should be used only when the construction schedule dictates a need for delaying the slab placement. When main slabs are keyed, it is necessary to dowel heavy reinforcing through the forms and then lap splice closely spaced slab reinforcing at a point of maximum stress. Deep key ways interfere with the vertical curtain of wall reinforcing particularly if it is necessary to waterstop the keyed joint. These problems are less evident in thin, lightly loaded slabs, and it is often more economical to key these slabs into the walls.

(6) Exterior concrete decks covering interior areas required to be dry should have a minimum thickness of 12 inches. Minimum reinforcement should be 0.75% of the cross sectional area with half distributed to each face. Waterstops should be provided at contraction joints, and construction joints should be treated as specified in guide specifications CW 03301.

(7) Vertical construction joints should be used to divide lift placements covering large areas into two or more smaller placements based on the following:

(a) Maximum rate concrete can be batched and placed without developing cold joints.

(b) Watertight concrete or other serviceability requirements affected by shrinkage cracking.

(c) Openings, blockouts or other discontinuities in the placement that tend to generate cracks.

(d) A need for a vertical construction joint, such as the one normally used between the intake and powerhouse structures, to allow flexibility in concrete placing schedules for different construction areas.

(e) The temperature-controlled concrete requirements.

(8) As a general guide, base slabs up to 100 feet wide, can be placed, without need for intermediate vertical joints, using a 3-inch aggregate, temperature-controlled concrete, and a batching and placing capability of 150 cubic yards per hour. Because of the tendency for shrinkage cracks to radiate out from the turbine pit blockout, the greatest dimension for a spiral case roof

pour should be limited to 70 feet, using 3-inch aggregate temperature-controlled concrete. By using additional reinforcing to minimize crack widths for satisfying the watertight concrete requirements, pour widths can be increased. With the added reinforcing, and by carefully establishing the temperature control requirements, it is seldom necessary to resort to segmented, waterstopped roof placements used in the past for unlimited concrete spiral cases.

(9) When vertical construction joints are required in the substructure, they should extend upward through the massive part of the structure, but need not extend into less massive piers, slabs or walls. Vertical construction joints should be keyed, and adequate shear friction reinforcing should be provided across the joint to develop the required shear capacity.

(10) A sloping construction joint should be located at the top of the main intermediate piers in the intake and draft tube. The roof of the water passage is then placed across the top of the prepared surface of the piers. Due to the slope of the roof, several horizontally placed lifts are usually required to complete the roof. Where the lift tends to feather out to the roof form, the pour line should be dubbed down 12 inches to eliminate the feathered edge.

(11) Consideration should be given to the location of horizontal construction joints on exposed faces. A V-notch rustication can be chamfering the joints in keeping with the architectural treatment.

4-8. Waterstops

Waterstops across contraction joints are necessary to prevent leakage and obtain satisfactory dry operating and working conditions. They are required to exclude water under head in the substructure and to ensure weather-tightness of the joints in the superstructure. Material of rubber or polyvinylchloride (PVC) is suitable for this purpose. Extensive experience in the use of molded rubber or extruded polyvinylchloride waterstops in joints of conduits and hydraulic structures have proved the practicability and advantages of using either of these materials. Copper waterstops were used in the past, however, they will fail where yielding foundations or other conditions result in differential movement between monoliths. They are also easily damaged during installation. PVC or rubber waterstops with a center bulb can withstand this type of movement and are recommended for use in hydroelectric products. A wider width is indicated for waterstops in the substructure where large

aggregate is used and higher water pressures exist than for waterstops to be installed in low-pressure areas or for weather-tightness only. Waterstops should be placed as near to the surface as practicable without forming weak corners in the concrete that may spall as a result of weathering, or impact, and should create a continuous barrier about the protected area. All laps or joints in rubber waterstops should be vulcanized or satisfactorily cemented together, and joints in "PVC" waterstops should be adequately heat sealed. Waterstops in contact with headwater for structures founded on rock should terminate in a recess formed by drilling holes 6 inches deep into the rocks and should be carefully grouted in place. Occasionally, double waterstops are required in pier joints, one on either side of a formed hole, containing bituminous material. In some important locations, two waterstops and a drain should be used to ensure water-tightness.

4-9. Draft Tubes

The outline of the draft tube is usually determined by the turbine manufacturer to suit the turbine operating requirements. However, in most cases, the manufacturer will be limited by certain physical requirements, such as the spacing and setting of the units, depth of foundations, and elevation of tailrace. The draft-tube portion of the substructure should be designed to withstand all loads that may be imposed on it, including superstructure loads, foundation reactions on the piers, tailwater on the roof, and the bursting effect of tailwater inside the draft-tube. Uplift under the floor of the draft-tube should also be considered in the design of the slab even when relief drains are provided. The upstream ends of intermediate piers should have heavy cast or structural steel nosing (usually furnished by the turbine manufacturer) to withstand the concentrated vertical load and to protect the piers from erosion. Piers between adjacent draft-tubes are usually bisected by the monolith contraction joint from which water is excluded by seals near the gate slot. Therefore, each half pier must be designed for the pressure of tailwater on the inside of the draft tube as a normal condition. It is advisable to consider also the possibility of unbalanced load in the opposite direction in case of failure of a contraction joint seal with the draft-tube unwatered.

4-10. Spiral Cases

a. General. Spiral cases should be designed to withstand the bursting pressure of maximum headwater plus water hammer.

b. *Types of spiral cases.* The type of spiral case depends on the power plant being considered.

(1) For low-head plants they may be of unlined concrete with engineered reinforcement to withstand applied dead, hydraulic and equipment loads.

(2) For medium and high head plants, they should be made of steel plate with shop welded longitudinal joints. Circumferential joints may be either field welded or high strength bolted, depending on the turbine manufacturer's design. Welded joints should be double-vee butt joints made under strict quality control and in accordance with the provisions of ASME. It is preferred that the "c" sections of spiral cases requiring field welding be butt-welded to skirt plates which should be shop-welded to the stay rings. All longitudinal welds should be radiographed. Ordinarily, stress relieving will not be required. When considering spiral cases under high head, and when shipping, handling, and erection cost would control, consideration should be given to the use of high strength steels. Completed spiral cases should be proof tested hydrostatically with a test pressure equal to 1-1/2 times the maximum design pressure.

c. *Construction details.*

(1) Consideration should be given to under-drainage of the turbine floor to intercept seepage upward through the spiral case roof. Under-drainage should consist of a grid of shallow trenches in the concrete subfloor covered by porous concrete planks, and overlaid by a 3 inch gravel bed. The vertical joint between the intake structure and the spiral case roof should contain a double waterstop and drain. Where the spiral case piers are placed in the first of a two-stage concreting operation described in paragraph 4-7c, and extend above the spiral case roof line, the joint between the piers and roof should be double waterstopped. Consideration should also be given to providing a grouted contact strip in the contraction joint between adjacent spiral case piers at approximately mid-height of the pier. When a unit is unwatered, unbalanced hydrostatic load will be shared by both piers. The contact strip is constructed by injecting grout into a formed recess about 3 inches wide and 12 inches high located in the contraction joint. A waterstop should be located just above and below the recess to prevent grouting the entire joint.

(2) The substructure may be "skeletonized" and the downstream wall and portions of the side walls or piers completed prior to embedment of the spiral case. In this case a minimum clearance of 2 to 3 feet must be left

between the spiral case liner and the concrete walls of the recess. The transition section from penstock to spiral case extension should not be encased. A penstock room or gallery should be provided to house the transition, penstock coupling, and when required, a butterfly or spherical closure valve. A Dresser-type coupling should be used to connect the penstock to the spiral case. The lifts of concrete around the spiral case liner should be limited to the depth specified in paragraph 4-7c. A minimum of 72 hours per lift shall elapse between the placing of each successive lift. Bent steel 'J'-pipes 6 inches or more in diameter should be provided for placing concrete under the stay ring, discharge ring, and spiral case. The number of 'J' pipes required depends on the size of the spiral case. Concrete may be pumped through the 'J' pipes using a positive displacement concrete pump. After concrete placement is complete the 'J' pipes should be filled with concrete and left in place.

d. *Embedment conditions.* Two methods of embedment of steel spiral cases in concrete are commonly used:

(1) When steel spiral cases are to be embedded in concrete in an unwatered condition, the top portion of the spiral case should be covered with a compressible membrane to ensure that the spiral case liner resists internal pressure by ring tension with only a small load being transmitted into the surrounding concrete. The compressible membrane should consist of sheets of closed cell foam material with the property that a 1/4-inch-thick piece deflects 0.10 inch under a 50-psi uniform pressure applied normal to the surface. Polyvinylchloride foam and polyurethane foam are acceptable, and the sheets of this material should be attached to the spiral case liner with an adhesive. The thickness of the membrane depends on the diameter and thickness of the spiral case liner, and the internal pressure being resisted. The compressible membrane should extend to the first construction joint below the horizontal centerline of the spiral case. A drain should be provided along the lower limits of the compressible membrane in order to prevent transmitting stress to the concrete through a water medium.

(2) When steel spiral cases are to be embedded in concrete under a pressurized condition, a test barrel is used to close off the opening between the upper and lower stay rings, and a test head is attached at the inlet of the spiral case extension. The spiral case is filled with water and pressurized to the test pressure or to a pressure equal to head water plus water hammer while encasement concrete is placed. Grout and vent holes in the stay ring are fitted with plugs which remain in place until the spiral case is unwatered. After concrete has been placed

at least one lift above the top of the spiral case, and the top lift has set at least 72 hours, the spiral case should be unwatered and the test barrel and test head removed. Workable concrete should then be placed through the bent steel 'J' pipes to fill the void under the stay ring/discharge ring. Neither a compressible membrane or drains are required for embedding spiral cases under the pressurized condition, except when low alloy steels or high strength quenched and tempered alloy steels are used for spiral case construction, consideration should be given to providing drains.

e. Concrete placing. The use of mechanical vibrators will not be permitted closer than 5 feet to any part of the spiral case, stay ring/discharge ring, or draft tube liner, except that small vibrators may be lowered through the grout holes in the stay ring to vibrate concrete placed through the steel 'J' pipes.

(1) Concrete placement through the steel 'J' pipes should be accomplished in a single lift operation which brings the concrete to within about 1 inch of the lower stay ring. After a minimum seven day cure period, grout fill pipes shall be attached to grout holes spaced evenly around the stay ring, and non-shrink grout injected at a head not exceeding 6 feet. A vent hole shall be located approximately midway between grout holes to permit escape of entrapped air and water.

(2) Concrete reinforcement above the spiral case should be designed to distribute the generator pedestal and turbine floor loads to the stay ring and the spiral case piers and walls.

4-11. Generator Pedestals

The generator, except in some low-head plants, is usually supported on a heavy concrete pedestal. The details of this pedestal will depend on the make and type of generator to be installed. It should be of massive construction and should be designed to resist vibrational forces from the moving mechanical parts, the heavy loads from the thrust bearing, and the short circuit torque of the generator. It is usually designed to support the generator room floor also. Openings in the pedestal should be provided on all four sides when practicable for access to and ventilation of the turbine pit. Adequate head room should be provided between the underside of the generator and the generator platform, if one is used, and between this platform and the turbine walkway.

4-12. Bulb Turbine Supports

Bulb turbines are supported in a much different manner than the typical vertical shaft Francis or Kaplan unit. A typical cross section of a bulb unit is shown in Figure 4-1. The main element of support for a bulb turbine is the stay column. It must carry the weight of the rotating parts, most of the stationary parts, and the hydraulic loads due to thrust, hydrostatic pressure, and transient loading. A typical stay column consists of an upper and lower support column fixed to the inner and outer stay cones. The inner stay cone forms the inner water passage and houses the turbine parts. The outer cone forms the outside water passage surface. This cone and both support columns are embedded in concrete, thereby transmitting all loads to the structure.

4-13. Types of Superstructures

The main superstructure may be one of three types: indoor, semi-outdoor, or outdoor. The indoor type completely encloses the generators and the erection bay and has an inside crane runway supported by the walls of the structure. The semi-outdoor type consists of a continuously reinforced slab over generators and erection bay supported by heavy transverse walls enclosing 2 or 3 units. The powerhouse crane is an outdoor gantry with one runway rail on each side of the low superstructure. Sliding hatches in the roof over each generator and in the erection bay provide access for handling equipment with the crane. In the outdoor type, each generator is protected by a light steel housing which is removed by the outdoor gantry crane when access to the machine is necessary for other than routine maintenance. The erection and repair space is in the substructure and has a roof hatch for equipment access. Choice of type should be dictated by consideration of first cost of the structure with all equipment in place, cost of maintenance of building and equipment, and protection from the elements. The indoor type affords greatest protection from the weather and facilitates operation and maintenance of equipment. The semi-outdoor type may sometimes have a marginal economic advantage insofar as it pertains to the cost of the structure, but this advantage will not always offset the increased equipment cost. The outdoor type is structurally the most economical at sites with low maximum tailwater. The structural economy must, however, be weighed against increased cost of generator housing, greater crane costs, and increased maintenance of equipment.

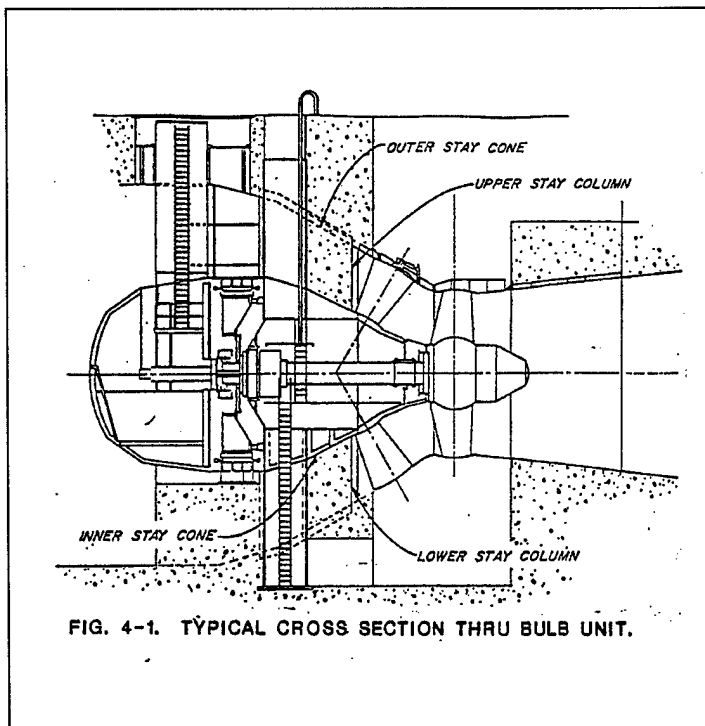

Figure 4-1. Typical cross section thru bulb unit

4-14. Superstructure - Indoor Powerhouse

a. *Framing.* The framing of the superstructure may be cast-in-place or precast reinforced concrete, prestressed concrete, structural steel, or a combination. The choice is dependent on economy and architectural requirements.

b. *Concrete walls.* Concrete exterior walls may be cast-in-place with uniform thickness, column and spandrel wall, precast panels, or prestressed precast units. They must all be designed to withstand the stresses from possible loading combinations and at the same time provide the necessary space requirements, both for embedded items and interior clearances. Provisions must usually be made for carrying loads imposed by bridge cranes and the rails are usually supported by continuous corbels or wall offsets at the elevation of the rails. Exterior concrete should not be rubbed nor should form liner be used, but a rigid specification for forming should be set up to insure reasonably smooth, plane surfaces. In some cases, special finishes, such as bush hammered or striated concrete, may be considered for special architectural effect. Matched tongue-and-groove lumber of 2-inch nominal thickness is satisfactory for sheathing.

Wall pours should not be made more than about 10 feet in height. Horizontal rustications should be used at the pour joints on the exterior side where practicable in order to prevent unsightly spalling; hence, locations of joints and pour heights will depend partly on the exterior architectural treatment. In the interior of the powerhouse where neat appearance is essential, it will be necessary to provide a smooth, dustless surface. The requirements for obtaining such a surface are contained in EM 1110-2-2000. Sack rubbing of the concrete surfaces should be avoided insofar as practicable. Contraction joints in the same vertical plane as those in the substructure should be provided in the superstructure walls. Criteria for openings in exterior walls are given in paragraph 3-1.

c. *Steel framing and walls.* While self-supporting concrete walls are usually preferred in the generator and erection bays, their justification is dependent upon economy and tailwater limitations. Where economically feasible, steel framing with curtain walls or insulated panels should be used where the generator floor is above the maximum tailwater. The use of steel framing may, in some cases, be desirable to permit the early installation and use of the crane runways and crane. This advantage should, however, be evaluated only in terms of

overall cost. The steel framing for each monolith should be a separate unit, with no steel except the crane rails crossing the contraction joints. Crane rail splices should be staggered a few inches with the joints. One bay in each monolith should be diagonally braced in both roof and walls. Bents may be composed of columns supporting simple beams or girders or may be rigid frames. Trusses should be used only if dictated by unusually heavy loads and long spans. In case it will usually be advantageous to weld shop connections and bolt field connections. Exceptions should be made for field splices in long rigid frames, which should be welded for structural continuity.

(1) If steel framing is used in other parts of the structure, it is usually of the conventional beam and column type used in office buildings.

(2) Suspended ceilings should be avoided unless economically justifiable. Inner tile walls to conceal the steel columns or rigid frames should be avoided. Not only is concealment of the steel considered unjustified but high thin walls are a hazard structurally.

d. Floors. Floors systems should be reinforced concrete flat slabs or one or two-way slabs with a 6-inch minimum thickness. The types of floor finishes and cove details designated for the various parts of the superstructure are given in paragraph 3-4a. Placement of concrete in floor slabs should be stopped sufficiently below finish grade to allow for appropriate finishes. The thickness of the structural slab will in many cases be determined by the member and size of electrical conduits which it must encase. Separate concrete fill placed on top of the structural slabs to encase conduits is uneconomical but can be used where large numbers of conduits must be accommodated, or where reinforcement in the structural slab is closely spaced. If used, it is recommended that the generator room floor be designed as a slab of uniform thickness, supported on the upstream and downstream walls and at the generator pedestal and carried on double columns at the contraction joints. Building contraction joints with water stops should be carried through all floor slabs. Shrinkage and temperature steel should be provided in the tops of all slabs. At hatchways through floors, flush sockets should be provided for the installation of temporary railings for protection of personnel at times when the covers are removed.

e. Roofs. Roof framing will usually consist of precast, prestressed units such as tee's, double tee's or hollow core plank. If structural steel framing is used, it will usually be fabricated steel girders supporting steel

purlins, which in turn, support the roof deck. Slope for drainage should be provided by the slope of the roof deck or the use of sloped insulation. The use of lightweight or sawdust concrete should be avoided. Insulation, embedded in hot bitumen or mechanically fastened should be applied over a vapor seal course to the roof slab or deck. Foam insulation should be avoided due to the unevenness of application. Thickness of insulation should be determined by an analysis of heating and cooling requirements. Roofing criteria are given in paragraph 3-2.

f. Future extensions. A temporary end wall must be provided for a superstructure which will at some future time, be extended to house additional units. The construction of the temporary wall should be such that it may be easily removed, and with a minimum of interference in the operation of the station. The temporary wall below the maximum tailwater elevation should be made of precast concrete slabs, supported on a steel framework, designed to resist the tailwater pressure, and sealed with rubber or polyvinylchloride water seals at all joints. The remainder of the temporary wall could be made of prefabricated metal panels which can be removed and possibly utilized in the future permanent end wall.

g. Vibration. The superstructure in the generator monoliths will be subject to vibration caused by the generating units. In order to minimize the effect of vibration on the main structural framing, the superstructure should be made as rigid as practicable. Concrete columns and walls should be integral with floor slabs and girders. Steel beams should be framed into columns and girders with full depth connections and not with seat angles alone. In some cases it may be desirable to use top flange clip angles also. Special attention should be paid to framing connections in light floors, balconies, stairways, and roofs and to fastenings of gratings, prefabricated metal panels, precast slabs and handrails. Threaded or welded handrail connections are preferred to pin connections. The effect of vibration in a generator monolith is, of course, greater on members close to the unit than on those at a distance. Also, members in parts of the structure separated from the generator monoliths by contraction joints will be less affected. Therefore, the designer must use careful judgment in determining the extent to which vibration will influence the design of such members.

4-15. Intakes

a. Type of intakes. Intakes may be classified as low pressure, or high pressure, according to the head on the

inlet, but there is no definite line of demarcation separating the two types. For low-head plants and for developments where the pool drawdown is small, low-pressure intakes are used. If the pool drawdown is to be large, such as on many multipurpose projects, the intake will be of the high-pressure type. It is advantageous to locate the intake high as practicable in order to minimize weights and travel distance of gates, size of hoist, etc., as well to keep the sill above possible silt deposits. Low-pressure intakes are usually incorporated in the dam and, for low-head plants, are also part of the powerhouse structure. High-pressure intakes may be in the dam itself or may be in a separate structure or structures in the forebay. The essential requirement if the two types are the same, but the details and equipment may be radically different. Features common to practically all intakes are: trash racks, gates, steel bulkheads, concrete stoplogs, or all three, and converging water passage or passages.

b. Shape of intake. The lines of the intake should be carefully laid out to obtain water velocities increasing gradually from the racks to the penstock, or to the spiral entrance. Abrupt changes in area of the water passage should be avoided in order to minimize turbulence and consequent power loss. The sections between the rectangular gate and the round penstock entrance is particularly important. The transition is ordinarily made in a distance about equal to the diameter of the penstock. Model tests are of great value in determining a satisfactory shape of intake, especially if Juvenile Fish Bypass is a design consideration.

c. Trash racks. Trash racks are usually vertical in order to economize on length if intake structure. For low-head intakes, however, where the increase in length of structure would be small or where considerable trash accumulation may be expected, they are often sloped to facilitate raking. Water velocities at the racks should be kept as low as economically practicable with a maximum, for low-pressure intakes, of about 4 feet per second. For high-pressure intakes, greater velocities are permissible but should not exceed about 10 feet per second.

(1) The racks are usually designed for an unbalanced head of 10 to 20 feet of water and are fabricated by welding in sections of a size convenient for handling. For low-head intakes, stresses due to complete stoppage and full head should be investigated and should not exceed 150 percent of normal stresses. If the racks are to be sheathed for the purpose of unwatering the intake, case II working stresses should not be exceeded for that loading condition. The clear distance between rack bars

varies from two to six inches or more, depending on the size and type of turbine and the minimum operating clearances. Bar thickness should be consistent with structural design requirements, with the vibrational effects resulting from flowing water being considered. A thick bar should be used with the depth of the bar controlled by the allowable working stress.

(2) The design of the guides and centering devices for the rack sections should receive careful attention. Clearances should be small enough to prevent offsets interfering with removal of the racks, or operation of a rake if one is provided. Embedded members on the guide slots should have corrosion-resisting exposed surfaces. Corrosion-resisting clad steel is satisfactory for the purpose.

(3) For high-pressure intakes in concrete dams, the trash rack supporting structure is sometimes built out from the face of the dam in the form of a semicircle in order to gain rack area to maintain low velocities.

d. Gates. Provisions for emergency closure of the intake downstream from the racks is necessary to protect the generator unit. A vertical lift gate in each water passage is usually provided and is normally suspended just above the roof of the intake from a fixed hoist. On very low-head multiunit plants a single set of intake gates operated by a gantry crane is adequate and will be less expensive than individual gates operated by fixed hoists. In either type of installation, self-closing tractor gates capable of operating under full flow are provided. Fixed wheel gates may be the most economical type for intakes where a gantry crane will be used for operation. Bronze-brushed wheel bearings should be used if the wheels will be submerged when the gate is in the stored position, otherwise, antifriction bearings can be used. For all but the lowest head intakes, "caterpillar" type gates with corrosion-resisting steel rollers and tracks have been found to be the most economical.

(1) In selecting the position of the gate slots, limiting velocities of flow as well as economical gate size should be considered. If the slots are located too far downstream, where the opening is small, power reduction from eddy losses may be more costly than a larger gate. The duration of peak demand on the plant will also affect the location of the slots, since a higher velocity may be tolerated for a short time. In any case, however, it is advisable to keep the maximum velocity V in feet per second below that given by the expression:

$$V = 0.12\sqrt{2gh}$$

in which h is the head on the center line of the gate at normal power pool.

(2) Slots for stop logs or bulkhead gates are usually provided just upstream from the gates so the gate slots may be unwatered for maintenance operations. In case where headwater is never far above the top of the intake, the racks are sometimes designed to support sheathing for unwatering.

(3) Essential fixed metal in the slop-log slots should have corrosion-resisting exposed surfaces, since these slots cannot be easily unwatered for repairs.

e. Air vents. Since emergency closure must be made under full flow conditions, negative pressures will tend to buildup at the top of the intake just downstream from a downstream-sealing gate as the gate is lowered. To prevent excessive negative pressures from occurring in the penstock during emergency gate closure and to exhaust air during penstock filling operations, one or more air vents should be provided just downstream from the gate. The air vents should be of sufficient size to maintain a pressure of not less than 1/2 atmosphere in the penstock at the maximum rate of depletion of water from the penstock under emergency closure conditions. The opening in the intake roof should be as close as practicable to the gate. The upper end of the air passage should be open to the atmosphere well above maximum headwater and in a location not readily accessible to personnel. Gates sealing on the upstream side are sometimes used. Air vents in the penstock may then be eliminated, as enough air will be introduced into the water passage through the opening between the downstream side of the gate and the concrete structure. Gate slots for both the upstream and downstream seal gates should be adequately vented by the use of open grating covers or by other means.

f. Prevention of ice troubles. Periods of freezing weather are likely to cause trouble with ice at low-pressure intakes, and the design of plants in northern latitudes should take this into account.

(1) Frazil and anchor ice may cause loss of head by forming on, or clogging rack openings, or may immobilize racks and gates by massing in the slots. Continuous surface ice tends to prevent the formation of frazil and anchor ice, and for this reason an ice sheet in the forebay is more beneficial than otherwise, except as it interferes with raking, or at breakup when it must be chuted to the tailrace or passed over the dam.

(2) Formation of ice may be prevented in the slots by means of electric heaters in casings embedded in the piers next to the guides and on the racks by a bubbler system with outlet nozzles just below the bottom of the racks and far enough upstream for the released air to carry the ice particles to the surface without coming in contact with the racks. At the surface the ice is sluiced to the tailrace.

4-16. Penstocks and Surge Tanks

a. Details and design. The determination of the diameter of penstock and the selection of size, type, and location of surge tank, if one is used, involve rather complex economic considerations. Therefore, only details of design will be discussed.

b. Free standing penstocks and surge tanks. The penstock should be designed for full pressure due to static head caused by maximum elevation of the operating range for the intake pool plus waterhammer. Waterhammer studies should be conducted to determine transient pressures at any point along its length. The following design conditions and their corresponding allowable stresses for carbon steels (see ASME, Boiler and Vessel Pressure Code, Sections 8 and 9 when other steels are used) are to be considered for these structures.

(1) This condition includes maximum, minimum, and rated turbine static heads plus waterhammer due to normal operation, load rejection and load acceptance. It also includes stresses due to gravity loads and longitudinal stresses due to penstock movement. The allowable stress for this basic condition is equal to the smaller of 1/4 of the specified tensile strength or 1/2 of the specified yield strength. The load acceptance condition includes minimum static head and loading the turbine from speed no load to full gate opening at the maximum rate of gate opening. This condition will indicate a minimum pressure grade line for the determination of sub atmospheric conditions. Amstutz buckling criteria should be used for embedded conduits. Stewart buckling criteria should be used for non-embedded conduits. If a valve is used as an emergency closure device, the conditions at maximum flow and maximum head with maximum valve closure rate must be analyzed.

(2) This includes conditions during filling and drainage of the penstock or surge tank and seismic loads during normal operation. The allowable stress for this condition is equal to 1/3 of the specified tensile stress or 2/3 of the specified yield point, whichever is less.

(3) This condition includes the governor cushioning stroke being inoperative and partial gate closure in $2L/a$ seconds at a maximum rate, where L equals the conduit length in feet and a equals the pressure wave velocity in feet per second. The allowable stress for this condition is equal to $1/2$ of the specified tensile strength, but in no case shall this stress exceed the specified minimum yield stress.

(a) After combining longitudinal and circumferential stresses in accordance with the Hencky-Mises Theory, where $S_e^2 = S_x^2 + S_y^2 + S_{xy}$, the allowable stresses are not to be exceeded by the resulting equivalent stress at any point on the penstock or surge tank.

(b) Minimum shell thicknesses are recommended for all steel penstocks to provide the rigidity needed during fabrication and handling. This minimum may be computed from the formula $T = D + 20/400$, where D equals the diameter in inches and T equals the minimum shell thickness in inches. A thinner shell may, in some cases, be used if proper stiffeners are provided during fabrication, handling, and installation.

(c) Welded joints should be butt-welds made under strict procedure control by qualified operators, and in accordance with the provisions of CW-05550, welded power penstock and surge tanks. All longitudinal seams should be examined radiographically in accordance with CW-05550.

(d) Completed penstocks with an operating head greater than 100 feet, should be hydrostatically tested with an internal pressure that will produce a hoop stress of 1.5 times the allowable stress. Penstocks with operating heads less than 100 feet should be pressure tested if they are unusually long, as may be the case of power tunnels or some conduits. Care should be taken when specifying test pressures to indicate where on the penstock the pressure is to be measured. This will ensure that the penstock is not overstressed during the test. If the entire penstock cannot be tested as a unit, individual sections are to be tested in the shop after they have been radiographed. The pressure should be applied three times, being increased and decreased slowly at the uniform rate. The test pressure should be held for a length of time sufficient for the inspection of all plates, joints, and connections for leaks or signs of distress. It is desirable that the test be performed when the pipe and water have a temperature of not less than 60 °F. The penstock should be vented at high points during filling to prevent formation of air pockets.

(e) Upon completion, and prior to insulation and painting, surge tanks should be tested by filling the tank with water to a point 1 foot from the top of the shell and maintaining this water level for not less than 24 hours, or such additional time as may be required to inspect all plates, joints, and connections for leaks or signs of distress. Preferred water and shell temperatures for the test should be not less than 60 °F.

(f) In long penstocks, a surge tank may be necessary to prevent the fluctuation of water-hammer flow from seriously interfering with turbine regulation (see 4-16(f)). Free-standing penstocks should be constructed so as to permit any leakage to drain to tailwater without pressurizing the surrounding regulating outlet conduit. Careful attention should be given to anchorage of the penstock against longitudinal thrust.

c. Power conduit linings. The function and many of the details of construction and erection for an integrally embedded steel liner are similar to a free-standing penstock; however, the loading conditions are different. The steel lining, concrete encasement, and if present, the surrounding rock act together to resist the pressures. EM 1110-2-2901 outlines in detail the loading conditions and allowable stresses for a conduit under embankments or rock. In both instances, external pressures must be accounted for as well as the internal pressures.

d. Water velocities and water hammer. The velocity of flow in penstocks depends largely upon turbine regulations but is seldom lower than 6 feet per second. In very high-head plants velocities as high as 30 feet per second have been used. For medium-head plants at maximum discharge, velocities of about 12 to 18 feet per second are typical. It should be noted that the allowable stresses for the components of the turbine spiral case, spiral case extension, valve, and valve extensions are different than those for the penstock. Refer to the guide specifications (CE-2201.01, CE-2201.02, and CE-2201.03, etc.) for these allowable stresses. The point of division between the penstock and spiral case/valve extension is customarily defined as the limit of supply for the turbine and/or valve manufacturer.

(1) Changes in the rate of flow in penstocks cause variations in pressure known as water hammer. These changes in flow rate can be caused by the turbine wicket gate motions due to power changes or load rejections, unit runaway, and closure of the emergency valve or gate. The magnitude of the pressure variation is dependent upon the length of penstock, the velocity of the

water, and the rate of change of the flow. When the turbine gates close due to a decrease in load, the pressure increases above the steady full load gradient. As the gate movement ceases, the gradient drops below that for steady full load, then fluctuates with diminishing amplitude between the maximum and minimum positions until the movement is damped out by friction. When an increase in load causes the turbine gates to open, the gradient first drops below that for steady full load, then fluctuates in a manner similar to that described for gate closure. The penstock must be designed at every point to withstand both the maximum and minimum pressure at that point as determined by the highest and lowest position of the water-hammer pressure gradient.

(2) The subject of water hammer is covered in *Hydroelectric Handbook* by Creager and Justin, *Handbook of Applied Hydraulics* by Davis, *Engineering Fluid Mechanics* by Jaeger, and *Waterhammer Analysis* by John Parmakian. Prior to development of plans and specifications, the hydraulic system should be modeled using a digital computer to simulate the various design conditions and configurations of the hydroelectric facility. The Corps has had a computer program (WHAMO) especially developed to simulate water hammer and mass oscillation in hydro-power and pumping facilities. This program or one equal to it should be used for this purpose. The Hydroelectric Design Center should be consulted prior to usage of WHAMO.

e. Bends, wyes, and tees. The distance from an elbow or bend in a penstock to the turbine inlet should be as great as the layout will permit in order that disturbances in the flow at the bend will not affect turbine performance. If a butterfly valve is used, its center line should be at least 3 penstock diameters upstream from the center line of the unit. The penstock must be anchored at bends to withstand the centrifugal forces of the water as it changes direction. Anchorages are usually blocks of mass concrete encasing the pipe. Wyes and tees involve internal pressures on noncircular sections and require special design. Often the entire wye branch or tee is encased in reinforced concrete, sometimes with embedded steel girders and tie rods, to prevent deformation and concentration of stresses in the shell. An example is the tee at a surge tank riser. Stress analysis of wyes and tees can be done as outlined in "Design of Wye Branches for Steel Pipe" published in the June 1955 edition of *Journal of The American Water Works Association*. For large structures or unusual configuration, a finite element analysis may be necessary.

f. Surge tanks and stability. For isochronous (isolated from the power grid) operation, a minimum ratio of water-starting time to mechanical starting time is required for stability. Usage of a surge tank (which decreases water starting time) or a flywheel (increases mechanical starting time) may be employed. Surge tanks also moderate water-hammer pressures. In long penstocks the fluctuation of water-hammer pressure may seriously interfere with turbine regulation unless relief is provided. For this purpose, a surge tank is generally used at the lower end of a penstock longer than about 400 feet. For simple surge tanks, the minimum area is usually 50 percent larger than the Thoma area. Isochronous operation capability should be provided for all but the smallest units. Surge tanks are of three basic types: simple, restricted-orifices, and differential. Also for underground stations where the rock is suitable, a surge chamber (accumulator) can be employed. A discussion of the advantages and disadvantages of each type as well as an outline of design procedures, is contained in Chapter 35 of *Hydroelectric Handbook* by Creager and Justin. *Waterhammer Analysis* by Parmakian also covers solutions of simple surge tanks. The WHAMO program is also capable of modeling all types of surge tanks as well as predicting hydraulic instability. It is recommended that the Hydroelectric Design Center or an engineer who has a successful record in surge tank design be retained to analyze the flow regulation problem and design the tank at any power project where long penstocks are to be used and isochronous unit operation is a requirement.

4-17. Switchyard Structures

The most suitable and economical general arrangement and design of outdoor high-voltage switchyards should be based on consideration of the scheme of high-voltage switching employed, the voltage and capacity of the main buses and transmission lines, the number of generator or transformer and transmission line bays required, the location of the main power transformers, the direction of transmission lines leaving the yard, and size and topography of the space available.

a. The switchyard should be arranged to provide adequate space for the safe movement of maintenance equipment and for the future movement of circuit breakers and other major equipment into position without de-energizing existing buses and equipment. A chain link woven wire fence approximately 7 feet with lockable gates should be provided to enclose the entire switchyard.

b. An arrangement using high truss-type structures and either strain or rigid-type buses required a minimum of ground area and is generally used for yards rated 161 kv and below. An arrangement using low flat-type structures with rigid buses is generally used for yards 230 kv and above and may also be used for lower-voltage yards where adequate space is available. This design utilizes separate A-frame structures for dead-ending the transmission lines and individual lightweight structures for supporting the buses, disconnects and other equipment. This arrangement is considered the most reliable and all equipment is easily accessible for inspection and maintenance.

c. The switchyard structures and transmission line take-off towers have special requirements in regard to loading, rigidity, resistance to shock, installation, and maintenance. Standards for the design of switchyard structures to meet these special requirements have been developed on the basis of long experience of the power industry and are summarized in NEMA Publication SG 67, "Power Switching Equipment."

d. The switchyard structures should be designed for the initial power installation but with provision for expansion as additional generating units and transmission lines are installed in the future.

4-18. Reinforcing Steel

Reinforcement should be designed using the requirements set forth in the latest edition of ACI 318 "Building Code Requirements for Reinforced Concrete," and as amended by EM 1110-2-2104 "Strength Design for Reinforced Concrete Hydraulic Structures." Guide specification CW-03210 "Steel Bars, Welded Wire Fabric and Accessories for Concrete Reinforcement" provides the necessary details for tests, cutting, bending, and splicing of reinforcement.

4-19. Encasement of Structural Steel

When the framing of the powerhouse is structural steel, the members shall not be encased, except for certain locations where appearance is a factor, such as office space and lobby, or where a fire hazard exists.

4-20. Retaining Walls

Walls subject to earth pressure, such as tailrace walls and foundation walls at the shore end of the powerhouse, may be of the gravity, semi-gravity or cantilever type, depending upon economy, and should be founded on solid rock wherever possible. Where sound rocks rises above the bottom of the tailrace at the shore side, excavation may be saved by anchoring a concrete facing to the rock and building the gravity wall above.

4-21. Area Drainage

Roof drains should be provided with basket-type strainers and should be connected to interior leaders discharging into the headwater or the tailrace. All floors should have flush drains to carry wash water, seepage, and possible leakage from tanks to the station sump or, if the area drained is well above maximum tailwater, to the tailrace.

a. Angles and abrupt bends in drain lines should be avoided insofar as possible, and cleanouts should be provided where necessary to facilitate clearing the pipes.

b. Floors should be sloped so that drains are well removed from electrical equipment, and particular attention should be paid to all details to avoid damage to such equipment caused by leaks or clogged drains.

c. In cold climates drain piping must be located where temperatures will not drop below freezing or must be properly insulated. Outlets should be well below tailwater to prevent formation of ice at the discharge.

4-22. Chamfers, Grooves, and Rustications

Exterior square corners are undesirable in concrete construction because of their tendency to break removal of forms or as a result of weathering or impact. Chamfers are usually formed on all exposed corners, but particular attention should be paid to this detail on the exterior walls. Chamfers of ample size should be provided at the ends of monoliths, forming V-grooves at the contraction joints. Horizontal V-grooves, or rustications are sometimes used for architectural reasons and lift heights should then be planned so that the rustication will occur at the horizontal joints.

Chapter 5 Physical Security

5-1. Protection Plan

For every hydropower installation a detailed, written protection plan shall be developed, which will use available resources in the most efficient manner. Although the primary area of concern should be protection from terrorist threats, all aspects of protection design should be addressed. (A recommended source of advice is the Missouri River Division (MRD), the Corps' Technical Center of Expertise for Protection Design.)

a. Type of protection. In determining the type and extent of physical protection required at an installation, the following pertinent factors should be taken into consideration in the indicated sequence.

- (1) Importance of the power supply to National Security, to the regional power base, and project operational requirements.
- (2) Definition and analysis of area to be protected, and other pertinent consideration inherent to the problem such as existing hazards, either natural or man-made. (Threats from the stored water in the reservoir, from landslide or avalanche, from forest or brush fire, etc.)
- (3) Operation, maintenance, and other requirements which must be integrated into the security plan.
- (4) Environment-political, economic, legal, surrounding terrain, weather and climate.
- (5) Costs of material and equipment to be installed, as well as availability of funds to provide at least minimum protection for all critical areas.

(6) Feasibility, personnel and equipment costs, and the best method of providing adequate cost effective protection.

b. Architectural design. The architectural design of the structure should incorporate necessary security design features.

- (1) A minimum of windows, particularly near ground level.
- (2) Well anchored steel doors and frames.
- (3) Transformers and power transmission lines located, or protected, to discourage threat activities.

c. Key elements in developing the protection plan. The response analysis should be assessed. The critical item to be estimated is the response time for security forces (project guards, local law enforcement agents, etc.) to reach the installation once they are alerted. The powerhouse operator should not be considered a part of the security forces. Once the response time is estimated, then a threat analysis should be performed. This would consider the most probable route of intruders to the most vulnerable areas of the hydropower installation. Then various delay zones (fences, walls, etc.) should be considered, each with its own intrusion detection system. The threat analysis should result in a series of delay zones so that the total time for the intruders to reach critical area of the hydropower installations, from first detection, exceeds the response time by security forces.

Chapter 6 Retrofitting Existing Projects

6-1. General

The addition of hydropower facilities at the existing Corps of Engineers projects must not jeopardize the public interest relative to water control management for flood control, navigation, water supply, water quality, recreation and other project purposes. In addition, those aspects of the design that could affect the safety of the project must be consistent with Corps standards as to requirements of this manual and all referenced manuals and regulations. To ensure compliance with this policy when development is by non-federal licenses, the Corps of Engineers will review and approve the proposed detailed design analysis and plans and specifications for those hydraulic, structural and mechanical features that could affect the integrity and safety of the total project. Major items of concern, but not necessarily limited to, are discussed as follows:

6-2. Hydraulic Design Considerations

a. Proposals. Proposals to add hydropower facilities at Corps of Engineers projects must thoroughly address the hydraulic design details and the overall functional capability. Items that must be addressed include the following.

- (1) Streamlining of entrance to power penstock from flood control conduit must be addressed.
- (2) Streamlining to preclude cavitation in flood control conduit at junctions with penstock or gate slots must be addressed.
- (3) Positive and negative pressure surges due to powerhouse load rejections, load acceptance, and unit runaway is another important item to address.
- (4) Reassessment of water quality provisions to include size and location of multi-level intakes and compatibility of powerhouse release requirements with water quality requirements is an important item.
- (5) Means of dewatering power facilities without interrupting water quality and/or flood control releases must be addressed. However, some powerhouses with long penstocks, or those with only gates or valves immediately upstream of the powerplant need not be

dewatered except under emergency conditions. This procedure can be followed only if it does not impact upon dam safety of flood control regulations. This type of penstock can be inspected using divers or remotely operated cameras.

(6) Effects of adding trashracks in the existing intake if required for equipment protection must be addressed.

b. Submittals. Submittals proposing inclusion or addition of hydropower combined with water quality and or flood control facilities at Corps of Engineers projects must include a hydraulic design analysis covering all operating and emergency conditions. Presentations need to address all items discussed above. Information on energy and pressure grade lines throughout the hydraulic passages covering maximum and minimum conditions with local pressure drops at such places as bends, junctions, transitions, gate slots, etc., is necessary. The presentations must include an analysis of the effects of a powerhouse load rejection. The degree of detail is to be sufficient for the study stage being presented, although at final design stage a transient analysis utilizing state-of-the-art computer programs must be performed and reviewed by a Design Center. The requirements apply to proposals from others (to be accomplished at their expense) as well as to in-house proposals.

c. Penstocks. The existing regulating outlet conduits offer an available connection between the reservoir and potential hydropower facilities. Regulating outlet conduits at flood control or other non-power projects are usually designed for non-pressurized (open channel) flow conditions. For the most part, these conduits are of reinforced concrete designed to withstand external rock or embankment loads and external hydrostatic pressures. Once hydropower facility is connected, the primary structural concern is that an existing regulating outlet conduit becomes a power penstock subject to internal pressures equal to full pool plus any transient pressures due to water hammer effects. Submittals proposing inclusion or addition of facilities at Corps of Engineers projects must include structural and geotechnical analysis covering all operating and emergency conditions. Presentations need to address all items covered in this guidance. The degree of detail presented should be sufficient for the study stage being presented. This applies to proposals from others (to be accomplished at their expense) as well as to in-house proposals. The following paragraphs present acceptable design criteria for converting regulating outlet conduits to power penstock (downstream control).

6-3. Geotechnical Considerations

Original geologic conditions upon which project design was based, and upon which cut and cover or lined or unlined tunnels were constructed, must be known so that safety and original design benefits are not reduced. Water must not be allowed to escape into the dam abutments from pressurized tunnels to cause slope stability problems or groundwater changes that might affect the dam. An investigation of geologic conditions relative to the design proposed for a pressurized tunnel must be made. Existing lined tunnels may conceal voids, shear zones, rock of low deformation modulus, etc. When modifying existing lined tunnels, design shall recognize and provide for the above possibilities, just as it would for unlined tunnels containing geologic weaknesses. Full length grouting behind linings or other measures may be necessary. If an existing tunnel is acting as a drainage feature in an abutment, intentionally or unintentionally, the possibility of groundwater pressure changes occurring after modification should be evaluated. The function and many of the details of construction and erection for an integrally embedded steel liner are similar to a free-standing penstock; however, the loading conditions are different. The steel lining, concrete encasement, and if present, the surrounding rock act together to resist the pressures. EM 1110-2-2901 outlines in detail the loading conditions and allowable stresses for a conduit under embankments or rock. In both instances, external pressures must be accounted for as well as the internal pressures.

6-4. Tunnels in Rock Abutments

An existing outlet tunnel (unlined or lined with other than steel) should be investigated to determine to what extent the tunnel should be lined with steel plate to prevent leakage that could present a danger to the dam or abutment. The extent of steel liner plate should be sufficient to prevent leakage along rock fissures or joints that intercept the dam or downstream of the impervious zone. An existing tunnel liner must be investigated for internal pressures that will occur once the hydropower facility is installed. In regions of an existing regulating outlet tunnel liner where the rock cover is insufficient to offset internal pressures, or where geologic weaknesses exist, a new liner may be required for structural reasons. A steel linerplate could be grouted in place and designed as composite with an existing concrete liner, provided the existing liner reinforcement is adequate for all loads (see EM 1110-2-2901). If the tunnel is unlined or if the existing liner reinforcement is inadequate, a separate

free-standing penstock or new reinforced concrete liner with composite steel liner plate should be provided.

6-5. Cut and Cover Conduits

a. General. In its existing non-pressurized condition, these conduits are generally reinforced concrete structures without steel plate liners. To prevent leakage that would endanger the embankment dam, a steel lining is required from the upstream face of the impervious zone to the powerhouse. A reinforced concrete liner composite steel liner plate, or a free-standing penstock, may be required to structurally accommodate the internal full pool pressures resulting from downstream control plus additional pressures due to water hammer effects.

b. Circular conduits. A steel liner grouted to be integral with the existing concrete liner may be used provided the requirements of EM 1110-2-2901 are met. If the existing concrete reinforcement does not meet the above requirements, a free-standing type penstock or new reinforced concrete liner with composite steel liner plate should be provided.

c. Non-circular conduits. A free-standing penstock, erected within and independent of the existing regulating outlet conduit, should be provided.

6-6. Free-Standing Penstocks Within Conduits

Free-standing penstocks constructed within an existing conduit shall be designed in accordance with paragraph 4-16, penstocks and surge tanks. Plates and joints should be designed for full pressure due to static head plus water hammer as well as any negative pressures developed by hydraulic transients. All joints should be welded except for the connection of the penstock to the spiral case, which is normally a flexible type. Free-standing penstocks should be constructed so as to permit any leakage to drain to tailwater without pressurizing the surrounding regulating outlet conduit. Careful attention should be given to anchorage of the penstock against longitudinal thrust.

a. Gates and valves. The addition of hydropower facilities must include provisions for isolating the powerplant so as not to interfere with the project original purpose. When the existing flood control conduit is modified for penstock use, a closure device such as a butterfly or spherical valve or a gate must be provided at the powerhouse end of the penstock for shutoff of flow

during emergency closure or during normal maintenance of the equipment.

(1) The closure device should be designed for maximum penstock head including water hammer and hydrostatically tested for 150 percent of the maximum design conditions. The valve operator must be capable of closing the device in from 2 to 5 minutes as practical for its size. The closure capability must be achievable without outside power. Thus, an energy storage device such as an accumulator or counterweight is required.

(2) The closure of the normal water passage at the downstream end for diverting flow to the turbine is subject to the specific project layout. Gates or valves used for this purpose must be designed for the maximum water pressure, including water hammer, and subject to hydrostatic testing in place.

b. Vents. When the existing flood control facilities are utilized for hydropower purposes, all the existing

components require careful analyzing and investigation for any adverse cavitation or structural effects. One such item subject to structural loading greater than originally thorough analysis of the effects such changes would have on the system when used in the original operation mode for the project purpose. During powerhouse operation the vents are subject to full hydrostatic pressure including water hammer, and therefore structural adequacy should be thoroughly investigated for this condition as well as the seismic condition.

c. Bifurcation. In most instances, the utilization of the existing regulating conduit requires diverting the water flow from the conduit to the power producing facilities. The method of accomplishing this objective requires a bifurcation or diverting box depending of the specific site conditions. The method chosen must be thoroughly analyzed for potential cavitation or structural effects and may require model testing to verify the design. For further structural requirements, see paragraph 4-16e.

Appendix A References

A-1. Required Publications

TM 5-809-1

Load Assumptions for Buildings

TM 5-809-10

Seismic Design of Buildings

TM 5-810-1

Mechanical Design, HVAC

ER 1110-2-109

Hydroelectric Design Center

ER 1110-2-1454

Non-Federal Hydropower

ER 1110-2-1806

Earthquake Design and Analysis for
Corps of Engineers Dams

EM 1110-2-1902

Stability of Earth and Rockfill Dams

EM 1110-2-2000

Standard Practice for Concrete

EM 1110-2-2104

Strength Design for Reinforced-
Concrete Hydraulic Structures

EM 1110-2-2105

Design of Hydraulic Steel Structures

EM 1110-2-2200

Gravity Dam Design

EM 1110-2-2502

Retaining and Floodwalls

EM 1110-2-2901

Tunnels and Shafts in Rock

EM 1110-2-2906

Design of Pile Foundations

EM 1110-2-3506

Grouting Technology

EM 1110-2-4203

Design Data for Powerhouse Cranes

EM 1110-2-4205

Hydroelectric Power Plant
Mechanical Design

ETL 1110-2-256

Sliding Stability for Concrete Structures (ETLs
are temporary documents and subject to change)

ETL 1110-2-301

Interim Procedures for Specifying Earthquake
Motions

ETL 1110-2-303

Earthquake Analysis and Design of
Concrete Gravity Dams

CE-1602

Dam Gantry Cranes

CE-1603

Draft Tube Gantry Cranes

CE-1604.01

Indoor Electrically Operated Traveling Cranes

CE-1604.02

Indoor Electrically Operated Traveling Cranes

CE-4000

Lump-Sum Contract for Design of
Hydroelectric Power Plant

CW-03210

Steel Bars, Welded Wire Fabric and Accessories
for Concrete Reinforcement

CW-03301

Standard Guide Specifications for Concrete

CW-03305

Standard Guide Specifications for Concrete

CW-05550

Welded Power Penstocks and Surge Tanks

CW-09940

Painting Hydraulic Structures and
Appurtenant Works

EM 1110-2-3001
30 Apr 95

American Society of Civil Engineers 1990

American Society of Civil Engineers. 1990. "Minimum Design Loads for Buildings and other Structures (ASCE 7-88), New York.

A-2. Related Publications

Creager and Justin 1950

Creager, W. P., and Justin, J. D. 1950. *Hydroelectric Handbook*, Second edition, John Wiley & Sons, Inc., New York.

Davis 1952

Davis, C. V. 1952. *Handbook of Applied Hydraulics*, Second edition, McGraw-Hill Book Co., New York.

Jaeger 1949

Jaeger, C. 1949. *Engineering Fluid Mechanics*, Blackie & Son, Ltd., London. (A translation by P.O. Wolf of Technische Hydraulik, Verlag Birkhauser, Basle, 1949.)

Miles Yanick and Company 1972

Miles Yanick and Company. 1972. *Visitors Facilities, Guidelines & Criteria Corps of Engineers*, North Pacific Division.

Parmakian 1955

Parmakian, J. 1955. *Waterhammer Analysis*. Prentiss Hall, New York.

Westergaard 1933

Westergaard, H. M. 1933. "Water Pressures on Dams during Earthquakes," *American Society of Civil Engineers, Transactions*, vol. 98, (1933), pp. 18-433. Discussion, pp. 434-472.

Powerplant	Units	Unit Spacing	Cl Dist. to Di. Ft.	Cl Dist. to Min. Ft	Discharge Sta.	Feet. Wt. (tons)	Generator Mfr.	KVA	PF	KW	Max. KW	KV	SC Ratio	Resistance
Albemarle	1-3	86	33	13	182	237.6	General Electric	15,778	80%	14,200	16,330	13.8	1.00	55.0%
Albemarle	4	64	18.5	7	186	850.8	Westinghouse	40,000	90%	30,000	41,400	13.9	1.293	43.0%
Albemarle	1-4	86	69	30*	30*	28	General Electric	2,600	80%	2,000	2,300	2.3	1.00	Normal
Berkley	1-2	61	42	7.2	185.25	81.5	Westinghouse	56,111	95%	32,500	42,500	13.8	1.100	51.0%
Beaver	1-2	89	70	2	278	250.5	Westinghouse	58,847	95%	58,500	64,000	13.8	1.175	31.8%
Big Bend	4-9	69	37	5	167.5	250.5	Westinghouse	81,579	95%	58,500	64,000	13.8	1.175	31.8%
Big Bend	1-2	89	37	5	167.5	250.5	Westinghouse	20,000	90%	18,000	18,000	14.4	1.100	31.8%
Big Bend	1-2	89	40	7	180	70	Westinghouse	41,667	80%	37,500	43,000	13.8	1.100	42.0%
Berkley	0	56	40	7	180	6	Elec. Mech. Corp.	5,000	80%	4,000	4,000	7.4	1.00	44.0%
Bonnaville 1	1	82	59.8	5.5	280	142	General Electric	48,000	80%	43,200	48,880	13.8	1.100	44.0%
Bonnaville 1	2	82	59.6	5.5	280	900	General Electric	48,000	80%	43,200	48,880	13.8	1.100	44.0%
Bonnaville 1	3-8	82	59.6	5.5	280	800	General Electric	60,000	80%	54,000	62,100	13.8	1.300	44.0%
Bonnaville 1	7-10	82	53.6	5.5	280	800	General Electric	60,000	80%	54,000	62,100	13.8	1.300	44.0%
Bonnaville 1	7-10	82	53.6	5.5	280	800	General Electric	60,000	80%	54,000	62,100	13.8	1.300	44.0%
Bonnaville 1	7-10	82	53.6	5.5	280	800	General Electric	60,000	80%	54,000	62,100	13.8	1.300	44.0%
Bonnaville 2	1	84	72.12	-7.87	331.2	1,125	General Electric	70,000	95%	66,500	66,500	13.8	1.175	42.0%
Bonnaville 2	1-18	84	72.12	-7.87	331.2	1,125	General Electric	70,000	95%	66,500	66,500	13.8	1.175	42.0%
Bonnaville 2	F1 & F2	43	30.5	-2.0	146	1,125	General Electric	13,800	95%	13,110	13,110	13.8	1.175	42.0%
Bonnaville 2	1-2	55	36	4.2	152.1	325	Allis-Chalmers	52,632	95%	50,000	57,000	13.8	1.175	41.0%
Broken Bow	1 & 2	62	38	7	180	423.25	Westinghouse	48,484	90%	45,000	48,000	13.8	1.100	42.0%
Burford	3	43	19	1.1	152.5	75	Westinghouse	45,105	95%	42,750	48,000	13.8	1.170	42.0%
Bull Shoals	1-6	64	33	10.7	152.5	36	Allis-Chalmers	47,388	95%	47,500	55,000	13.8	1.175	41.0%
Bull Shoals	1-6	64	33	10.7	152.5	36	Allis-Chalmers	131,579	90%	125,000	143,750	13.8	1.175	37.0%
Center Hill	1 & 2	63	33	-2.2	180.5	80	General Electric	131,579	90%	125,000	143,750	13.8	1.175	37.0%
Center Hill	1-3	58	38	3.8	180.5	80	General Electric	50,000	90%	45,000	52,000	13.8	1.100	43.0%
Center Hill	SS	75	15	0.2	182	560	Elliot	13,333	90%	12,000	13,500	13.8	1.100	54.0%
Chattahoochee	1-3	82	47	0.2	282.5	332.5	Westinghouse	67,368	95%	64,000	67,368	13.8	1.170	43.0%
Chief Joseph	5-14	20	42	7	198.8	332.5	Westinghouse	67,368	95%	64,000	67,368	13.8	1.170	43.0%
Chief Joseph	17-27	20	42	7	218	332.5	Westinghouse	100,000	95%	95,000	100,000	13.8	1.175	32.4%
Chief Joseph	SS 1 & 2	22	28.5	4	38	4	Elliot	721	4%	3,000	3,000	7.4	1.000	Normal
Chief Joseph	SS 1 & 2	75	47.2	9	185	520	General Electric	28,421	96%	27,000	27,000	13.8	1.100	45.0%
Clemens Canyon	1-3	82	30	6.5	230	1045	General Electric	37,637	30%	33,333	33,333	13.8	1.100	45.0%
Cordell Hull	1-3	42	18	5.5	64.2	75	Elliot	13,168	95%	14,375	14,375	6.9	1.175	35.0%
Cougar	1-3	42	24	7	113.5	248	Westinghouse	20,000	80%	18,000	18,250	13.8	1.100	42.0%
Dardanelle	1-4	90	60	4.5	166.5	720	Westinghouse	52,632	95%	51,000	56,900	13.8	1.175	48.0%
Dardanelle	1-4	90	60	4.5	166.5	720	Westinghouse	42,105	95%	40,000	49,900	13.8	1.175	40.0%
De Gray	2	49	218" 184" bott. 32 210' min. to 223' top	7	184.38	89.5	Allis-Chalmers	23,474	95%	22,000	24,200	13.8	1.175	43.0%
De Gray	1 & 2	64	43	7	191.8	60	Westinghouse	55,556	100%	50,000	57,500	13.8	1.600	31.0%
Denison	1 & 2	51	36	4.8	159	208.5	General Electric	15,000	100%	15,000	17,250	13.8	1.260	48.0%
Dexter	1-2	47	36	1	128	208.5	Allis-Chalmers	94,737	95%	90,000	90,000	13.8	1.176	63.0%
Dwartzak	1 & 2	64	46	7	192	860	Allis-Chalmers	233,694	95%	222,000	222,000	13.8	1.175	25.4%
Eufaula	1-3	81	42	8.2	182	443.2	Westinghouse	31,579	95%	30,000	34,500	13.8	1.176	48.0%
Fert Gheen	1-4	53	34.25	8	151.25	5	Allis-Chalmers	32,959	90%	35,600	40,250	13.8	1.100	39.0%
Fert Gheen	1 & 3	48	32	9.25	149.50	25	Allis-Chalmers	16,987	80%	15,000	17,250	13.8	1.260	40.0%
Fert Pack, Plant No. 1	2	58	36	6	165.8	54.7	Elliot	42,105	95%	40,000	46,000	13.8	1.170	42.0%
Fert Pack, Plant No. 2	5	70	42	9	204	55	Westinghouse	42,105	95%	40,000	46,000	13.8	1.170	42.0%
Fert Pack, Plant No. 2	5	70	42	9	204	55	Westinghouse	42,105	95%	40,000	46,000	13.8	1.170	42.0%
Fert Pack, Plant No. 2	5	70	42	9	204	55	Westinghouse	42,105	95%	40,000	46,000	13.8	1.170	42.0%
Foster	1 & 2	40	24	10	95.84	64.7	Allis-Chalmers	10,528	95%	10,000	11,500	4.2	1.750	42.0%
Garrison	1-5	75	45	4.7	210.5	178.5	General Electric	84,211	95%	80,500	84,000	13.8	1.360	38.6%

ABB = Atlas Brown Boveri
Note: Before using any dimensional data, consult the equipment drawings.
Fig. Hydro.etc

Powerplant	Units	Wk's	Gen. Dis.	Gen. Wt. (tons)	Power on Line	Rawlnd Mfr.	Rawlnd Capacity	Rawlnd Above Cap.	Rawlnd Date
Alamo Hills	1-3	55,000,000	48'	117.5	418 See notes.	ABB Power Generation, Inc.	47,000 KVA @ 90PF		See notes.
Alamo Hills	1 & 2	89,000	38'	28.25	2/17/60	ABB Power Generation, Inc.	3,000 KVA	34.50 KVA	1984
Alamo Hills	4	89,000	38'	28.25	2/17/60	ABB Power Generation, Inc.	3,000 KVA	34.50 KVA	1984
Alamo Hills	1 & 2	114,000,000	60'	489.5	1/20/66	ABB Power Generation, Inc.	67,274	58,500	1/1/83
Beaver	1 & 2	109,400,000	45'	877.5	See notes.	Magnetek RI Elec Co			See notes.
Big Bend	1-3	109,400,000	45'	877.5	See notes.	Magnetek RI Elec Co			See notes.
Big Bend	4-8	109,400,000	45'	877.5	See notes.	Magnetek RI Elec Co			See notes.
Big Bend	1 & 2	114,000,000	40'	484	10/1/55				
Bonnaville 1	1	113,000,000	48'	335.5	5/17/38				Not Rawlnd
Bonnaville 1	2	113,000,000	48'	335.5	5/17/38				Not Rawlnd
Bonnaville 1	3-6	113,000,000	48'	1,000	See notes.	NEC	54,200	59,400	Jun-78
Bonnaville 1	7-10	113,000,000	48'	1,000	See notes.				
Bonnaville 1	1 & 2	113,000,000	48'	1,000	See notes.				See notes.
Bonnaville 2	11-14	164,960,000	52.17'	850	See notes.				
Bonnaville 2	15-18	164,960,000	52.17'	850	See notes.				
Bonnaville 2	1 & 2	4,231,000	22' x 30'	165	See notes.	Thomas Elec.	50,000	57,500	UT, 04/84; UZ, 12/84.
Broken Bow	1 & 2	34,400,000	40'	348.5	See notes.				
Broken Bow	1 & 2	83,288,887	32'	53	See notes.				
Broken Bow	1 & 2	94,000,000	12'	93	7/23/55				
Bull Shoals	1-4	34,000,000	40'	360	See notes.	NEC	45,000	51,750	4/8/83
Bull Shoals	5-8	34,000,000	40'	360	See notes.	NEC	45,000	51,750	4/8/83
Bull Shoals	1 & 2	95,700,000	42'	362.8	See notes.	ABB Power Generation, Inc.	125,000 KW	143,750	UT, 03/12/82; UZ, 02/12/82.
Bull Shoals	3 & 4	95,700,000	42'	362.8	See notes.	ABB Power Generation, Inc.	125,000 KW	143,750	UT, 03/12/82; UZ, 02/12/82.
Carter's	1-3	55,000,000	44'	651	See notes.				1/1/83
Carter's	4	55,000,000	44'	651	See notes.				1/1/83
Center Hill	1-3	47,500,000	44.17'	431.6	1/951				
Center Hill	4	47,500,000	44.17'	431.6	1/951				
Chief Joseph	1-4, 15 & 16	84,000,000	42.5'	800	See notes.	Westinghouse	88,270	92,920	1/1/87
Chief Joseph	5-14	84,000,000	42.5'	800	See notes.	Westinghouse	88,270	92,920	1/1/87
Chief Joseph	17-27	96,600,000	48'	540	DE/7/10/85/79				Rawlnd date: 1/1/1983
Chief Joseph	SS 1 & 2	76,000	12.33' Max	29.5	Jun-86				
Clermont Cannon	1	15,500,000	48'	432.5	Nov-84				
Clermont Cannon	2	15,500,000	48'	432.5	Nov-84				
Cordell Hull	1-3	114,000,000	54.17' Max	584.5					
Cordell Hull	1 & 2	1,488,000	22'	101.8					
Dale Hollow	1-3	7,500,000	28.33'	195.8					1/1/81
Dardanelle	1-4	54,500,000	42.67'	460					1/1/78
De Grey	1	34,000,000	38'	331	See notes.				
De Grey	2	34,000,000	38'	331	See notes.				
De Grey	1 & 2	55,000,000	39.17'	497	See notes.				
Dexter	1 & 2	29,000,000	38.25'	580					
Dexter	1 & 2	9,000,000	31.87'	282					
Dworshek	1 & 2	36,200,000	38.08'	318.7					
Dworshek	3	200,000,000	48.17'	821	4/20/73	Siemens			1/1/76
Eufaula	1-3	31,800,000	39.17'	238.5	1/2/73				
Eufaula	4	31,800,000	39.17'	238.5	1/2/73				
Fort Shaw	1 & 3	30,000,000	46'	350	See notes.	NEC	43,500	60,025	1978
Fort Shaw	2 & 4	30,000,000	46'	350	See notes.	NEC	43,500	60,025	1978
Fort Shaw	1 & 2	7,000,000	25.5'	165	See notes.	NEC	19,250	20,988	1978
Fort Shaw	3 & 5	39,500,000	35.33'	411.4					
Fort Shaw	1-4	82,000,000	43'	614	See notes.				
Fort Randall	1-4	2,000,000	43'	614	See notes.				
Fort Randall	1 & 2	2,000,000	43'	614	See notes.				
Fort Randall	1 & 2	150,000,000	See notes	1,122.50			109,250	109,250	11/23/85
Garrison	1-3	150,000,000	50'	1,122.50					

ABB = Asea Brown Boveri
Note: Before using any dimensional data, consult the equipment drawings.
File: Hydro.xls

Powerplant	Units	Notes
Abund Falls	1-3	
Alamoona	1 & 2	
Alamoona	4	
Amador	1-4	
Beaver	1 & 2	
Big Bend	1-3	
Big Bend	4-8	
Big Cliff	1 & 2	
Black Mt.	0	
Bonanza	1	
Bonanza	2	
Bonanza	3	
Bonanza	4	
Bonanza	5	
Bonanza	6	
Bonanza	7	
Bonanza	8	
Bonanza	9	
Bonanza	10	
Bonanza	11	
Bonanza	12	
Bonanza	13	
Bonanza	14	
Bonanza	15	
Bonanza	16	
Bonanza	17	
Bonanza	18	
Bonanza	19	
Bonanza	20	
Bonanza	21	
Bonanza	22	
Bonanza	23	
Bonanza	24	
Bonanza	25	
Bonanza	26	
Bonanza	27	
Bonanza	28	
Bonanza	29	
Bonanza	30	
Bonanza	31	
Bonanza	32	
Bonanza	33	
Bonanza	34	
Bonanza	35	
Bonanza	36	
Bonanza	37	
Bonanza	38	
Bonanza	39	
Bonanza	40	
Bonanza	41	
Bonanza	42	
Bonanza	43	
Bonanza	44	
Bonanza	45	
Bonanza	46	
Bonanza	47	
Bonanza	48	
Bonanza	49	
Bonanza	50	
Bonanza	51	
Bonanza	52	
Bonanza	53	
Bonanza	54	
Bonanza	55	
Bonanza	56	
Bonanza	57	
Bonanza	58	
Bonanza	59	
Bonanza	60	
Bonanza	61	
Bonanza	62	
Bonanza	63	
Bonanza	64	
Bonanza	65	
Bonanza	66	
Bonanza	67	
Bonanza	68	
Bonanza	69	
Bonanza	70	
Bonanza	71	
Bonanza	72	
Bonanza	73	
Bonanza	74	
Bonanza	75	
Bonanza	76	
Bonanza	77	
Bonanza	78	
Bonanza	79	
Bonanza	80	
Bonanza	81	
Bonanza	82	
Bonanza	83	
Bonanza	84	
Bonanza	85	
Bonanza	86	
Bonanza	87	
Bonanza	88	
Bonanza	89	
Bonanza	90	
Bonanza	91	
Bonanza	92	
Bonanza	93	
Bonanza	94	
Bonanza	95	
Bonanza	96	
Bonanza	97	
Bonanza	98	
Bonanza	99	
Bonanza	100	

ABB = Asa Brown Boveri
Note: Before using any dimensional data, consult the equipment drawings.
File: Hydro.xls

Powerplant	Unit	Station	District	Type	River, County, State	Turbine Mfr.	HP	BRM	Rated Head	Max. Head	Min. Head
Gavin's Point	1, 2	CENPD	Orshan	Kaplan	Macon River, York Co., SC	Baldwin-Lima-Hamilton	54,000	75	48'	80'	40'
Green Hill	1, 2	CENPD	Portland	Francis	Saratoma River, York Co., OR	Allis-Chalmers	55,000	163.6	265'	321'	168'
Green Hill	1	CENPD	Portland	Francis	Saratoma River, York Co., OR	James Lefell	2,000	900	200'	250'	161'
Gross Ferry	1 & 2	CESWD	Little Rock	Francis	Little Rock River, Boone Co., MO	Baldwin-Lima-Hamilton	66,300	120	176'	214'	158'
Harry S. Truman	1 & 2	CENPD	Kansas	Francis	Orange River, Benton Co., AR	Baldwin-Lima-Hamilton	92,400	100	700'	767'	143'
Hartwell	1-4	CESAD	Savannah	Francis	Savannah River, Hart Co., GA	Newport News Shipbldg. & Drydock Co.	108,600	112.5	170'	187'	143'
Hill Creek	1 & 2	CESAD	Savannah	Francis	Savannah River, Hart Co., GA	Baldwin-Lima-Hamilton	21,700	277	256'	320'	181.5'
Ice Harbor	1-3	CENPD	Walla Walla	Kaplan	Snake River, Walla Walla Co., WA	Allis-Chalmers	174,000	85.7	89'	105'	78'
Island Creek	1-3	CESAD	Wilmington	Francis	Roanoke River, Mecklenburg Co., VA	S. Morgan Smith	1,280	800	300'	300'	72'
J. Percy Priest	1	CESAD	Nashville	Fixed Blade Prop.	Roanoke River, Mecklenburg Co., VA	Allis-Chalmers	62,700	128.6	300'	341'	165'
J. Strom Thurmond	1-7	CESAD	Savannah	Francis	Savannah River, McIntosh Co., SC	Newport News Shipbldg. & Drydock Co.	14,000	75	26.5'	33'	14'
Jim Woodruff	1-3	CENPD	Portland	Kaplan	Columbia River, Sherman Co., OR	Baldwin-Lima-Hamilton	212,400	90	84'	110'	83.5'
John Day	1-4	CENPD	Portland	Kaplan	Columbia River, Sherman Co., OR	Baldwin-Lima-Hamilton	212,400	90	84'	110'	83.5'
John Day	8-11	Raw'd	Portland	Kaplan	Columbia River, Sherman Co., OR	Baldwin-Lima-Hamilton	212,400	90	84'	110'	83.5'
John Day	13	Raw'd	Portland	Kaplan	Columbia River, Sherman Co., OR	Baldwin-Lima-Hamilton	212,400	90	84'	110'	83.5'
John H. Kerr	1-5	CESAD	Wilmington	Francis	Roanoke River, Mecklenburg Co., VA	James Lefell	1,400	450	90'	108'	60'
John H. Kerr	2, 5	CESAD	Wilmington	Francis	Roanoke River, Mecklenburg Co., VA	Baldwin-Lima-Hamilton	17,000	138.5	80'	108'	60'
John H. Kerr	6 & 7	CESAD	Wilmington	Francis	Roanoke River, Mecklenburg Co., VA	Newport News Shipbldg. & Drydock Co.	45,000	85.7	80'	108'	60'
John H. Kerr	1-4	CESAD	Mobile	Fixed Bl. Prop. (4 Blades)	Roanoke River, Mecklenburg Co., VA	Newport News Shipbldg. & Drydock Co.	23,480	72	28.2'	41.5'	10'
John H. Kerr	1-4	CESAD	Mobile	Fixed Bl. Prop. (4 Blades)	Roanoke River, Mecklenburg Co., VA	Allis-Chalmers	49,000	120	74'	97'	66'
Keystone	1 & 2	CESAD	Tuscaloosa	Fixed Blade Prop.	Roanoke River, Mecklenburg Co., VA	Allis-Chalmers	38,000	144	237'	1030.5'	882'
Lane	1-4	CENPD	Seattle	Francis	Kootenai River, Lincoln Co., MT	Allis-Chalmers	185,000	128.6	300'	341'	165'
Libby	1-5	CENPD	Seattle	Francis	Kootenai River, Lincoln Co., MT	Allis-Chalmers	185,000	128.6	300'	341'	165'
Little Goose	1-3	CENPD	Walla Walla	Kaplan	Snake River, Columbia Co., WA	Baldwin-Lima-Hamilton	212,400	90	84'	105'	78'
Little Goose	4-6	CENPD	Walla Walla	Kaplan	Snake River, Columbia Co., WA	Allis-Chalmers	52,800	128.6	185'	233'	178'
Lower Granite	1 & 2	CENPD	Walla Walla	Kaplan	Snake River, Columbia Co., WA	Baldwin-Lima-Hamilton	33,800	240	275'	321'	197'
Lower Monumental	1-3	CENPD	Walla Walla	Kaplan	Snake River, Columbia Co., WA	Baldwin-Lima-Hamilton	212,400	90	93'	105'	78'
Lower Monumental	4-6	CENPD	Walla Walla	Kaplan	Snake River, Columbia Co., WA	Allis-Chalmers	212,400	90	84'	105'	78'
Lower Monumental	1-3	CENPD	Walla Walla	Kaplan	Snake River, Columbia Co., WA	Allis-Chalmers	212,400	90	84'	105'	78'
Lower Monumental	4-6	CENPD	Walla Walla	Kaplan	Snake River, Columbia Co., WA	Allis-Chalmers	212,400	90	84'	105'	78'
McHenry	1-12	CENPD	Walla Walla	Kaplan	Snake River, Umatilla Co., OR	S. Morgan Smith	11,300	65.7	80'	97'	62'
McHenry	13 & 14	CENPD	Walla Walla	Kaplan	Snake River, Umatilla Co., OR	S. Morgan Smith	4,800	277	80'	97'	62'
McHenry	95 1 & 2	CESAD	Mobile	Fixed Bl. Prop. (5 Blades)	Roanoke River, Mecklenburg Co., VA	Baldwin-Lima-Hamilton	34,000	69.3	35.5'	47.5'	14'
Northwest	1 & 2	CESAD	Walla Walla	Francis	Lower Miss. River, Pike Co., AR	Baldwin-Lima-Hamilton	12,000	225	132'	153.5'	98'
Northwest	1-7	CESAD	Walla Walla	Francis	Lower Miss. River, Pike Co., AR	Baldwin-Lima-Hamilton	12,000	225	132'	153.5'	98'
Northwest	1-7	CESAD	Walla Walla	Francis	Lower Miss. River, Pike Co., AR	Baldwin-Lima-Hamilton	12,000	225	132'	153.5'	98'
Northwest	1-7	CESAD	Walla Walla	Francis	Lower Miss. River, Pike Co., AR	Baldwin-Lima-Hamilton	12,000	225	132'	153.5'	98'
Northwest	1-7	CESAD	Walla Walla	Francis	Lower Miss. River, Pike Co., AR	Baldwin-Lima-Hamilton	12,000	225	132'	153.5'	98'
Old Hickory	1 & 2	CESWD	Little Rock	Francis	White River, Baxter Co., AR	S. Morgan Smith	136,500	106	185'	203'	114'
Ozark	1-4	CENPD	Walla Walla	Francis	Snake River, Umatilla Co., OR	Allis-Chalmers	45,000	75	85'	97'	62'
Ozark	1-4	CENPD	Walla Walla	Francis	Snake River, Umatilla Co., OR	Allis-Chalmers	45,000	75	85'	97'	62'
Ozark	1-4	CENPD	Walla Walla	Francis	Snake River, Umatilla Co., OR	Allis-Chalmers	45,000	75	85'	97'	62'
Paltoilet	3	CESAD	Wilmington	Francis	Roanoke River, Mecklenburg Co., VA	Allis-Chalmers	27,800	514	271	35	17
Paltoilet	1 & 2	CESAD	Wilmington	Francis	Roanoke River, Mecklenburg Co., VA	James Lefell	9,400	277	152	176	108
Paltoilet	3	CESAD	Wilmington	Francis	Roanoke River, Mecklenburg Co., VA	James Lefell	860	720	152	176	108
Paltoilet	1 & 2	CESAD	Wilmington	Francis	Roanoke River, Mecklenburg Co., VA	James Lefell	860	720	152	176	108
R.D. Wake	55 1	CESAD	Fort Worth	See notes.	Neches River, Tyler Co., TX	See notes.	5,800	1687.20	10.432'	16	19
Richard B. Russell	1 & 2	CESWD	Savannah	Francis	Savannah River, Hart Co., GA	Baldwin-Lima-Hamilton	104,000	120	144'	162'	134'
Richard B. Russell	5-8	CESAD	Savannah	Francis	Savannah River, Hart Co., GA	Domination Engineering Works	104,000	120	144'	162'	134'
Richard B. Russell	1-4	CESAD	Savannah	Francis	Savannah River, Hart Co., GA	Allis-Chalmers	46,000	75	40.6'	47'	20'
Robert S. Kerr	1-4	CESWD	Tuscaloosa	Kaplan	Akansee River, Sequoyia Co., OK	Allis-Chalmers	46,000	75	40.6'	47'	20'

ABB = Area Brown Bovel

Note: Before using any dimensional data, consult the equipment drawings.

File: Hydro.xls

Equipment	Units	Notes
Green Bluff	1-3	POL: U1,08/10/68; U2,10/15/68; U3,01/18/67.
Green River	1-2	
Green River	F 1	
Green River	F 1	
Greene Ferry	1-2	POL: U1,03/64; U2,05/64. Formally "Kayahnger Bluff".
Harry S. Truman	1-2	
Hartwell	1-4	
Hartwell	1-2	
Hartwell	1-3	
Ice Harbor	4-6	POL: U1,12/18/61; U2,02/27/62; U3,02/08/62. POL: U4,11/24/76; U5,11/19/76; U6,01/07/76. See Pumping Data.
Island Creek	1-3	
J. Percy Priest	1-7	
J. Strom Thurmond	1-3	POL: U1,01/06/63; U2,02/28/63; U3,04/28/63; U4,10/06/63; U5,01/20/64; U6,05/27/64; U7,07/28/64. Formally "Clark Hill".
John Day	1-1	POL: U1,02/19/67; U2,03/01/67; U3,04/26/67.
John Day	6-11 Rew'd	POL: U1,09/18/67; U2,12/25/67; U3,12/04/60; U4,12/14/64. POL: U6,03/27/68; U7,07/02/68; U8,03/16/69; U9,07/18/65; U10,09/19/69; U11,03/09/80.
John Day	13 Rew'd	
John Day	16 Rew'd	
John H. Kerr	1-1	POL: A,09/30/52; B,09/27/52. Rewind: U1,17 JUNE 1965?
John H. Kerr	2-8	POL: U2,03/21/63; U3,11/15/62; U4,01/20/63; U5,08/21/63.
John H. Kerr	6 & 7	POL: U6,10/27/57; U7,12/05/59. POL: U1,06/27/75; U2,07/15/75; U3,09/05/75; U4,10/24/75. Associated with the Robert F. Henry Lock & Dam. Rewind dates: U1,06/27/75; U2,07/15/75; U3,09/05/75; U4,10/24/75. Associated with the Robert F. Henry Lock & Dam.
Jonas Bluff	1-4	
Keystone	1-2	POL: U1,05/22/68; U2,05/22/68.
Libby	1-4	Rewinds: U1 - U4.
Libby	1-5	Rewinds: U5.
Little Goose	1-3	POL: U1,03/26/70; U2,10/30/70; U3,12/09/70. POL: U4,01/26/78; U5,06/19/78; U6,07/05/78.
Little Goose	4-8	
Lookout Point	1-2	
Lower Granite	1-2	Runner + Shaft: 38960ft; Max. KW 1,154,24500 = 28176; Mech. Cap. = 296657; POL: U1,07/09/77; U2,07/15/77; U3,07/15/77; U4,07/15/77; U5,07/15/77. POL: U1,03/15/75; U2,05/08/75; U3,09/24/76. POL: U4,12/15/77; U5,02/01/78; U6,03/01/78. POL: U1,05/28/69; U2,09/08/69; U3,01/09/70.
Lower Monumental	1-3	
McNary	4-6	POL: U4,07/18/79; U5,02/03/79; U6,04/23/79. POL: U1,10/06/53; U2,12/28/53; U3,04/10/54; U4,09/18/54; U5,09/23/54; U6,12/30/54; U7,02/28/55; U8,04/28/55; U9,07/28/55; U10,01/12/55; U12,04/05/56. POL: U1,03/08/56; U1,14,12/18/56. Gen. Wtd.: English Electric Esport & Trading Co.
McNary	13 & 14	
Millers Ferry	1-3	POL: U1,04/15/70; U2,04/20/70; U3,05/27/70. POL: U1 & U2, MAY 1950.
Narrows	1-2	
Narrows	3	
Narrows	1-2	
Narrows	1-7	POL: U1,02/08/60; U2,07/46 Rewind Dates: U1,12/66; U2,12/86; U3,05/66; U4,04/64; U6,05/66; U7,06/64.
Oake	1-2	
Og Rickety	1-5	
Phillips	1-2	POL: U1,09/14/63; U2,09/07/63.
Phillips	3	
Phillips	5S 1	
R.D. Willis	1 & 2	Type: Horizontal Standardized Double Regulated S Turbine. Formally "Town Bluff Dam".
Richard B. Russell	1-4	Installed 6/63; Under going acceptance testing as of 12/84.
Richard B. Russell	1-3	POL: U1,07/71; U2,09/71; U3,10/71; U4,11/71.
Richard B. Russell	1-4	

ABB = Ases Brown Boveri
Note: Before using any dimensional data, consult the equipment drawings.
File: Hydro.xls

Powerplant	Units	Division	District	Type	River	County	State	Urban Mfr.	HP	RPM	Rated Head	Max. Head	Min. Head
Sam Harpoun	1 & 2	CESWD	Fort Worth	Kaplan	Anguilla River	Jasper Co.	TX	Allis-Chalmers	41,300	120	70'	88'	53'
St. Mary's Falls	1-3	CEKRD	Detroit	Fixed Blade Prop.	St. Mary's Rr.	Chippawa Co.	MI	Allis-Chalmers	0,975	90	21'	22.8'	18.3'
St. Mary's Falls	5A	CEKRD	Detroit	Kaplan	St. Mary's Rr.	Chippawa Co.	MI	S. Morgan Smith	3,000	128.8	18.3'	22.8'	18.3'
St. Mary's Falls	10	CEKRD	Detroit	Fixed Blade Prop.	St. Mary's Rr.	Chippawa Co.	MI	Allis-Chalmers	3,000	128.8	20'	22.8'	18.3'
St. Stephens	1-3	CEKRD	Charleston	Fixed Blade Prop.	Sarraf/Cooper Rrs.	Berkeley Co.	SC	Allis-Chalmers	39,000	100	49'	57.9'	44.3'
Stockton	1	CEKRD	Kansas City	Kaplan	Sac River	Cozart Co.	MO	Newport News Shipbldg. & Drydock Co.	71,800	75	91'	108'	77'
Table Rock	1-4	CEKRD	Little Rock	Francis	White River	Taney Co.	MO	English Elect. Export & Trading Co.	69,000	128.6	180'	228'	136'
Tanklender Ferry	1 & 2	CESWD	Tulsa	RTORO	Winoth River	Cherokee Co.	OK	S. Morgan Smith	23,500	150	132'	181'	103.5'
The Dales	1-14	CEKRD	Portland	Kaplan	Columbia River	Wasco Co.	OR	Badwin-Lima-Hamilton	123,000	85.7	81'	90.5'	60'
The Dales	15-22	CEKRD	Portland	Kaplan	Columbia River	Wasco Co.	OR	Badwin-Lima-Hamilton	136,000	80	73'	90'	58'
The Dales	F 1 & 2	CEKRD	Portland	Francis	Columbia River	Wasco Co.	OR	Allis-Chalmers	18,900	200	74'	88'	55'
The Dales	SS 1 & 2	CEKRD	Portland	Francis	Columbia River	Wasco Co.	OR	Pelton	4,500	277	81'	90.5'	60'
The Dales	5 Rew'd	CEKRD	Portland	Kaplan	Columbia River	Wasco Co.	OR	Badwin-Lima-Hamilton	123,800	85.7	81'	90.5'	60'
The Dales	12 Rew'd	CEKRD	Portland	Kaplan	Columbia River	Wasco Co.	OR	Badwin-Lima-Hamilton	123,800	85.7	81'	90.5'	60'
The Dales	13 Rew'd	CEKRD	Portland	Kaplan	Columbia River	Wasco Co.	OR	Badwin-Lima-Hamilton	123,800	85.7	81'	90.5'	60'
Walter F. George	1-4	CEKRD	Mobile	Kaplan	Chattahoochee Rr.	Henny Co.	AL	Newport News Shipbldg. & Drydock Co.	45,500	112.5	70'	88'	37'
Webber's Falls	1-3	CESWD	Tulsa	Kaplan (Tube Type)	Arkansas River	Nutley Co.	OK	Allis-Chalmers	33,800	60.2	28.5' to 31'	31'	17'
West Point	1	CEKRD	Mobile	Fixed Blade Prop.	Chattahoochee Rr.	Troup Co.	GA	James Leffel	5,400	327	77'	77'	82'
West Point	2 & 3	CEKRD	Mobile	Fixed Blade Prop.	Chattahoochee Rr.	Troup Co.	GA	Newport News Shipbldg. & Drydock Co.	51,500	100	58'	73'	52'
Whinnery	1 & 2	CESWD	Fort Worth	Francis	Brass River	Bosque Co.	TX	Newport News Shipbldg. & Drydock Co.	20,700	128.9	91.5'	126'	77.5'
Wolf Creek	55	CEKRD	Nashville	Francis	Cumberland Rr.	Russell Co.	KY	James Leffel	2,000	800	160'	214'	111'
Wolf Creek	1-3	CEKRD	Nashville	Francis	Cumberland Rr.	Russell Co.	KY	Badwin-Lima-Hamilton	62,500	105.9	180'	214'	111'
Wolf Creek	4-6	CEKRD	Nashville	Francis	Cumberland Rr.	Russell Co.	KY	Badwin-Lima-Hamilton	62,500	105.9	180'	214'	111'

ABB = Asea Brown Boveri
Note: Before using any dimensional data, consult the equipment drawings.
File: Hydro.xls

Powerplant	Units	Unit Spacing	CI Dist. to DI, Ft.	CI Dist. to Min. Tur	Discharge Dis.	Turb. Wt. (tons)	Generator Mfr.	KVA	Pf	KW	Max. KW	KV	SC Ratio	Resistance
Sam Rayburn	1 & 2	57	45	65	180	293.9	Westinghouse	27,368	85%	8,000	28,000	13.8	1.175	44.0%
St. Mary's Falls	1-3	54	31	38	110		General Electric	See notes	90%	8,000	28,000	13.8	1.100	40.0%
St. Mary's Falls	2A	28	21	38	110		General Electric	3,126	90%	2,500	2,500	4.2	1.000	30.0%
St. Mary's Falls	1-3	70	53	15	110		General Electric	3,110	90%	2,500	2,500	4.2	1.400	24.28%
St. Stephens	1-3	70	71	12	222	48	Westinghouse	47,578	95%	45,200	48,000	13.8	1.175	37.0%
St. Stephens	1-4	54	38	72	150.5	38	Westinghouse	52,832	95%	50,000	57,500	13.8	1.175	41.0%
Table Rock	1-4	42	See notes	79	116.13	38	Fluor	20,578	95%	18,550	22,500	13.8	1.700	44.0%
Walker Ferry	1 & 2	86	70.7	-16	280	1,085	General Electric	82,105	95%	78,000	85,000	13.8	1.175	44.0%
The Dales	1-1A	86	70.7	-14	300	1,085	General Electric	14,210	95%	13,500	14,000	13.8	1.175	44.0%
The Dales	1E-22	40	35.5	-14.5	120	167.5	Westinghouse	14,210	95%	13,500	14,000	13.8	1.175	44.0%
The Dales	F 1 & 2	27	50.3	-5.5	65.5	42.5	Elec. Mach. Corp.	3,750	90%	3,000	3,000	4.2	1.000	Normal
The Dales	5 Raw'd	88	70.7	-16	280	1,085	General Electric	82,105	95%	78,000	85,000	13.8	1.175	44.0%
The Dales	12 Raw'd	86	70.7	-16	280	1,085	General Electric	82,105	95%	78,000	85,000	13.8	1.175	44.0%
The Dales	13 Raw'd	86	70.7	-16	280	1,085	General Electric	82,105	95%	78,000	85,000	13.8	1.175	44.0%
Walter F. Geoyge	1-4	67	45.5	1.2	198	150	Fluor	38,111	90%	32,500	37,375	13.8	1.100	37.0%
Webber's Falls	1-3	65	42.5	14.5	215	745	General Electric	21,053	95%	20,000	23,000	13.8	1.175	32.0%
West Point	1	61.5	18	5	72	4.5	General Electric	3,750	90%	3,375	3,881	3.8	1.842	37.0%
West Point	2 & 3	77	52	3	230.63	49	General Electric	36,842	95%	35,000	40,250	13.8	1.178	38.0%
Whitney	1 & 2	46	30	6.5	130.75	20	Allis-Chalmers	16,887	80%	15,000	15,000	480V	1.000	45.0%
Wolf Creek	SS	58	17	8	324.69		Elliott	1,500	90%	1,200	1,500	480V	1.000	45.0%
Wolf Creek	1-3	58	38	7	175	55	General Electric	50,000	90%	45,000	57,500	13.8	1.100	43.0%
Wolf Creek	4-6	58	38	7	175	55	General Electric	50,000	90%	45,000	57,500	13.8	1.100	43.0%

ABB = Asa Brown Boveri
Note: Before using any dimensional data, consult the equipment drawings.
Fig. Hydro.xls

Powerplant	Units	WK-2	Gen. Dia.	Gen. Wt. (tons)	Power on Line	Rawind Mfr.	Rawind Capacity	Rawind Above Cap.	Rawind Date
Sam Reinhorn	1 & 2	20,700,000	32.67	303					
St. Mary's Falls	1-3	6,750,000	25.92	166.6		General Electric			Begin 08/84
St. Mary's Falls	3A	1,500,000	17.3	82.6		NEC	3,250	3,250	Begin 1886
St. Mary's Falls	10	1,500,000	16.33						
St. Stephens	1-3	27,600,000	32	334	Jan-85				
Stockton	1	86,500,000	48	416.3					
Table Rock	1-4	40,000,000	38	438	See notes.				
Tentler Ferry	1 & 2	8,500,000	18.58	75.5	1951	UT, Nat'l Coll, U2, West ght	19,500		See notes. 01,05/20/83; U2, 1978
The Dalles	1-14	136,000,000	50.97	804.9					
The Dalles	16-22	163,000,000	50.36	804.9					
The Dalles	1 & 2	2,300,000	27.88	166					
The Dalles	8 & 1 & 2	300,000	16	50.5					
The Dalles	6	136,000,000	50.97	843	01/13/82				
The Dalles	9	136,000,000	50.97	843	06/02/82				
The Dalles	13	136,000,000	50.97	843	06/02/82				
The Dalles	13	136,000,000	50.97	843	06/02/82				
Webber's Falls	1-3	600,000	36	115	See notes.				
West Point	1	275,000	16	43.9	11/10/75				
Whitney	2 & 3	35,200,000	42	289.9	See notes.				
Wolf Creek	1 & 2	11,000,000	33	215.5	7/1/63				
Wolf Creek	5S	55,000,000	40	560	12/9/18/51				17/86
Wolf Creek	1-3	55,000,000	40	560	See notes.				17/86
Wolf Creek	4-6	55,000,000	40	560	See notes.				17/86

ABB = Asa Brown Boveri
Note: Before using any dimensional data, consult the equipment drawings.
File: Hydro.xls

Powerplant	Units	Notes
Sum Ryburn	1 & 2	
St. Mary's Falls	1-3	5333 x 1.15 = 6132
St. Mary's Falls	3A	
St. Mary's Falls	10	
St. Stephens	1-3	
Stockton	1	
Table Rock	1-4	ROL: U1, 06/22/68; U2, 06/21/68; U3, 04/21/61; U4, 06/18/61
Tenkiller Ferry	1 & 2	CL: 27' to bott. allow of DT 16. Rewind Over Cap: U1 & U2, 15% 23,600 KVA; 27' to bottom of draft tube.
The Dalles	1-16	
The Dalles	15-22	
The Dalles	F 1 & 2	
The Dalles	RS, 1 & 2	
The Dalles	5 Rew B	
The Dalles	12 Rew d	
The Dalles	13 Rew d	
Walter F. George	1-4	ROL: U1, 03/13/69; U2, 05/10/65; U3, 08/20/63; U4, 08/27/63.
Webber's Falls	1-3	ROL: U1, 08/7/73; U2, 09/7/73; U3, 11/73.
West Point	1	
West Point	2 & 3	ROL: U2, 04/10/75; U3, 03/10/75.
Whitney	1 & 2	
Wolf Creek	95	
Wolf Creek	1-3	ROL: U1, 08/20/62; U2, 07/24/62; U3, 03/17/62.
Wolf Creek	4-6	ROL: U4, 12/10/61; U5, 10/31/61; U6, 10/26/61.

ABB = Asa Brown Goveril
 Note: Before using any dimensional data, consult the equipment drawings.
 File: Hydro.xls

Powerplant	Units	Division	District	Type	River, County, State	Turbine Mfr.	HP	RPM	Rated Head	Max. Head	Min. Head
Carter's	3 & 4	CEB&D	Mobile	Francis	Coosawattas R., Murray Co., GA	Allis-Chalmers	173,000	150	345'	403'	315'
Clarence Cannon	2	CEINW	St. Louis	Francis	Salt River, Bull Co., MO	Allis-Chalmers	42,800	75	75'	107'	89'
De Gray	2	CEINW	Wakarusa	Francis	Clado River, Clark Co., AR	Newport News Shipbldg. & Drydkt. Co.	43,249	128.5	171'	216'	144'
Harry S. Truman	1-8	CEB&D	Kansas	Adv. Blade & Incl. Axle	Grass River, Benton Co., MO	Baldwin-Loss-Hamilton	42,400	100	42.5'	79.2'	41'
Island Creek	1-3	CEB&D	Washington	Adv. & Adj. Blade	Roanoke River, Mecklenburg Co., VA	S. McCran Smith	1,250	600	40'	50'	
Richard B. Russell	5-8	CEB&D	Savannah	Francis	Savannah River, Effort Co., GA	Domination Engineering Works	123,400	120	144'	182'	139'
Robert F. Henry					Alabama River, Lowndes Co., AL						

Powerplant	Units	Unit Spacing	CI Dist. to Dr. Th.	CI Dist. to Min. Tw	CI Dist. to Min. Tw Pump	Discharge Dia.	Inlet Dia.	Turb. Wt. (tons)	Pump HP	Pump Cfs
Carter's	3 & 4	83'	33'	-22'	-21'	170"	248"	40	185,000	4,435
Clarence Cannon	2	82'	50'	-9'	0'	231"	270.4"	1,038		5,600
De Gray	2	49'	216" bott. 194', top 223'	20'	-1'	194.38"	195.8"	69.5	44,500	1,800
Harry S. Truman	1-6	52'	30.9'	20'	.28'	255.6"	254"	136	42,500	4,500
Island Creek	1-3	14'				57"		1,000	1,250	210
Richard B. Russell	5-8									
Robert F. Henry										

Powerplant	Units	Pump Hd.	Pump Max. Hd.	Pump Min. Hd.	Notes
Carter's	3 & 4	347'	403'	315'	
Clarence Cannon	2	60'	75'	60'	
De Gray	2	171'	180'	150'	Pump runs between 215' to 408'
Harry S. Truman	1-8	50'	50'	44.5'	Formerly "Kawfischer Buflf"
Island Creek	1-3	50'	50'		Pumps water into the John H. Kerr Dam.
Richard B. Russell	5-8	148'	181'	141'	
Robert F. Henry					

ABS - Ases Brown Boveri
Note: Before using any dimensional data, consult the equipment drawings.
File: Pump.xls