

**US Army Corps  
of Engineers**

**ENGINEERING AND DESIGN**

---

EM 1110-2-2000  
3 February 1994

# **Standard Practice for Concrete for Civil Works Structures**

**DISTRIBUTION STATEMENT A**  
Approved for Public Release  
Distribution Unlimited

**ENGINEER MANUAL**

**20020626 125**

CECW-EG  Engineer Manual 1110-2-2000	Department of the Army U.S. Army Corps of Engineers Washington, DC 20314-1000	EM 1110-2-2000  1 February 1994
	Engineering and Design  STANDARD PRACTICE FOR CONCRETE FOR CIVIL WORKS STRUCTURES	
	<b>Distribution Restriction Statement</b> Approved for public release; distribution is unlimited.	

**DEPARTMENT OF THE ARMY  
U.S. Army Corps of Engineers  
Washington, DC 20314-1000**

**EM 1110-2-2000  
Change 2**

CECW-EI

Manual  
No, 1110-2-2000

31 March 01

**Engineering and Design  
STANDARD PRACTICE FOR CONCRETE  
FOR CIVIL WORKS STRUCTURES**

1. This Change 2 to EM 1110-2-2000, 1 February 1994, provides updated guidance for the selection of aggregates in Chapter 2.

2. Substitute the attached pages as shown below:

Remove Page	Insert page
2-10	2-10
2-11	2-11

3. File this change sheet in front of the publication for reference purposes.

FOR THE COMMANDER:



**ROBERT L. DAVIS**  
Colonel, Corps of Engineers  
Chief of Staff

CECW-ED

DEPARTMENT OF THE ARMY  
U.S. Army Corps of Engineers  
Washington, DC 20314-1000

EM 1110-2-2000  
Change 1

Manual  
No. 1110-2-2000

31 July 94

**Engineering and Design  
STANDARD PRACTICE FOR CONCRETE  
FOR CIVIL WORKS STRUCTURES**

1. This Change 1 to EM 1110-2-2000, 1 February 1994, updates Chapter 2.
2. Substitute the attached pages as shown below:

Remove page	Insert page
2-1	2-1
2-6	2-6

3. File this change sheet in front of the publication for reference purposes.

FOR THE COMMANDER:



WILLIAM D. BROWN  
Colonel, Corps of Engineers  
Chief of Staff

DEPARTMENT OF THE ARMY  
US Army Corps of Engineers  
Washington, DC 20314-1000

EM 1110-2-2000

CECW-EG

Manual  
No. 1110-2-2000

1 February 1994

**Engineering and Design**  
**STANDARD PRACTICE FOR CONCRETE**  
**FOR CIVIL WORKS STRUCTURES**

**1. Purpose.** The purpose of this manual is to provide information and guidance for the investigation and selection of concrete materials for civil works concrete structures. Elements discussed include design studies and reports, preparation of contract plans and specifications, construction preparation, and concrete construction quality verification. Emphasis is placed on the problems of concrete for hydraulic structures. Roller-compacted concrete, shotcrete, rigid pavement, architectural concrete, and concrete for repairs are not included. These subjects are discussed in EM 1110-2-2006, Roller-Compacted Concrete; EM 1110-2-2005, Standard Practice for Shotcrete; TM 5-822-7, Standard Practice for Concrete Pavements; EM 1110-1-2009, Architectural Concrete; and EM 1110-2-2002, Evaluation and Repair of Concrete Structures, respectively.

**2. Applicability.** This manual is applicable to all HQUSACE elements, major subordinate commands, districts, laboratories, and field operating activities having civil works responsibilities.

FOR THE COMMANDER:



WILLIAM D. BROWN  
Colonel, Corps of Engineers  
Chief of Staff

**DEPARTMENT OF THE ARMY  
US Army Corps of Engineers  
Washington, DC 20314-1000**

EM 1110-2-2000

CECW-EG

Manual  
No. 1110-2-2000

1 February 1994

**Engineering and Design  
STANDARD PRACTICE FOR CONCRETE  
FOR CIVIL WORKS STRUCTURES**

**Table of Contents**

Subject	Paragraph	Page	Subject	Paragraph	Page
<b>Chapter 1</b>			Portland cement and blended		
<b>Introduction and Policy</b>			hydraulic cements . . . . .		
Purpose . . . . .	1-1	1-1	Pozzolans . . . . .	2-2d(2)	2-5
Applicability . . . . .	1-2	1-1	GGBF slag . . . . .	2-2d(3)	2-6
References . . . . .	1-3	1-1	Silica fume . . . . .	2-2d(4)	2-6
Explanation of Abbreviations . . . . .	1-4	1-1	Aggregates . . . . .	2-2d(5)	2-6
Engineering Responsibilities			General . . . . .	2-3	2-6
and Requirements . . . . .	1-5	1-1	General . . . . .	2-3a	2-6
Reconnaissance phase . . . . .	1-5a	1-1	Sources of aggregate		
Feasibility phase . . . . .	1-5b	1-1	(Government or commercial) . . . . .	2-3a(1)	2-6
Preconstruction engineering and			Minor structures . . . . .	2-3a(2)	2-7
design phase . . . . .	1-5c	1-1	Availability investigation . . . . .	2-3b	2-7
Construction phase . . . . .	1-5d	1-1	General . . . . .	2-3b(1)	2-7
Delays in Contract Awards . . . . .	1-6	1-2	Service records . . . . .	2-3b(2)	2-7
<b>Chapter 2</b>			Field exploration and sampling		
<b>Investigation and Selection of Materials</b>			of undeveloped sources . . . . .	2-3b(3)	2-7
Introduction . . . . .	2-1	2-1	Field exploration and sampling		
Cementitious Materials . . . . .	2-2	2-1	of developed sources . . . . .	2-3b(4)	2-7
General . . . . .	2-2a	2-1	Testing potential aggregate		
Types . . . . .	2-2b	2-1	sources . . . . .	2-3b(5)	2-8
Portland cement . . . . .	2-2b(1)	2-1	Evaluating aggregate qualities . . . . .	2-3b(6)	2-8
Blended hydraulic cement . . . . .	2-2b(2)	2-1	Nominal maximum size		
Pozzolan . . . . .	2-2b(3)	2-1	aggregate . . . . .	2-3b(7)	2-12
GGBF slag . . . . .	2-2b(4)	2-1	Fine aggregate grading		
Other hydraulic cements . . . . .	2-2b(5)	2-1	requirements . . . . .	2-3b(8)	2-12
Silica fume . . . . .	2-2b(6)	2-1	Required tests and test limits . . . . .	2-3b(9)	2-13
Air-entraining portland cement . . . . .	2-2b(7)	2-1	Aggregate processing study . . . . .	2-3b(10)	2-13
Selection of cementitious materials . . . . .	2-2c	2-1	Location of government-furnished		
General . . . . .	2-2c(1)	2-1	quarry or pit . . . . .	2-3b(11)	2-13
Type of structure . . . . .	2-2c(2)	2-1	Water for Mixing and Curing . . . . .	2-4	2-14
Other requirements . . . . .	2-2c(3)	2-2	General . . . . .	2-4a	2-14
Requirements for use of other			Mixing water . . . . .	2-4b	2-14
hydraulic cements . . . . .	2-2c(4)	2-4	Curing water . . . . .	2-4c	2-14
Pozzolans . . . . .	2-2c(5)	2-4	Chemical Admixtures . . . . .	2-5	2-14
Availability investigation of			General . . . . .	2-5a	2-14
cementitious materials . . . . .	2-2d	2-5	Air-entraining admixtures . . . . .	2-5b	2-14
General . . . . .	2-2d(1)	2-5	Policy . . . . .	2-5b(1)	2-14
			Strength loss . . . . .	2-5b(2)	2-15



Table of Contents (Continued)

Subject	Paragraph	Page	Subject	Paragraph	Page
Test method . . . . .	3-2c(2)	3-6	Reviewing contractor submittals . . . . .	4-5b	4-8
Application of test results . . . . .	3-2c(3)	3-6	Minor structures . . . . .	4-5b(1)	4-8
Mixer grinding studies . . . . .	3-2d	3-6	Cast-in-place structural concrete . . . . .	4-5b(2)	4-8
Concrete subjected to high velocity					
flow of water . . . . .	3-2e	3-7			
General . . . . .	3-2e(1)	3-7			
Quality of concrete . . . . .	3-2e(2)	3-7			
Construction joints . . . . .	3-2e(3)	3-7			
Unformed surfaces . . . . .	3-2e(4)	3-7			
Formed surfaces . . . . .	3-2e(5)	3-7			
Unusual or complex problems . . . . .	3-2f	3-7			
<b>Chapter 4</b>			<b>Chapter 5</b>		
<b>Mixture Proportioning Considerations</b>			<b>Preparation of Plans and Specifications</b>		
Selection of Concrete Mixture			Selection of Guide Specification		
Proportions . . . . .	4-1	4-1	for Concrete . . . . .	5-1	5-1
Basis for Selection of			General . . . . .	5-1a	5-1
Proportions . . . . .	4-2	4-1	Guidelines for selection . . . . .	5-1b	5-1
General . . . . .	4-2a	4-1	Use of state specifications . . . . .	5-1c	5-1
Economy . . . . .	4-2b	4-1	Use of abbreviated specifications . . . . .	5-1d	5-1
Strength . . . . .	4-2c	4-1	Guide Specification "Concrete (for Minor		
Durability . . . . .	4-2d	4-1	Structures)", CW-03307 . . . . .	5-2	5-1
Placeability . . . . .	4-2e	4-1	General . . . . .	5-2a	5-1
Criteria for Mixture			Cementitious materials options . . . . .	5-2b	5-1
Proportioning . . . . .	4-3	4-2	Selection of compressive strength . . . . .	5-2c	5-1
General . . . . .	4-3a	4-2	Selection of nominal maximum		
Proportioning criteria . . . . .	4-3b	4-2	aggregate size . . . . .	5-2d	5-1
Maximum permissible w/c . . . . .	4-3b(1)	4-2	Finish requirements . . . . .	5-2e	5-2
Structural concrete . . . . .	4-3b(2)	4-2	Guide Specification "Cast-in-Place Structural		
Mass concrete . . . . .	4-3b(3)	4-2	Concrete," CW-03301 . . . . .	5-3	5-2
Nominal maximum aggregate			General . . . . .	5-3a	5-2
size . . . . .	4-3b(4)	4-5	Testing of cementitious materials . . . . .	5-3b	5-2
Water content . . . . .	4-3b(5)	4-5	Admixtures and curing compounds . . . . .	5-3c	5-2
Cement content . . . . .	4-3b(6)	4-6	Testing of aggregate . . . . .	5-3d	5-2
Proportioning with pozzolans			Nonshrink grout . . . . .	5-3e	5-2
or GGBF slag . . . . .	4-3b(7)	4-6	Cementing materials option . . . . .	5-3f	5-2
Government Mixture Proportioning . . . . .	4-4	4-6	Specifying aggregate . . . . .	5-3g	5-3
General . . . . .	4-4a	4-6	Strength . . . . .	5-3h	5-3
Coordination between project, district			Batch-plant capacity . . . . .	5-3i	5-3
design personnel, and the division			Batch-plant controls . . . . .	5-3j	5-3
laboratory . . . . .	4-4b	4-6	Concrete deposited in water . . . . .	5-3k	5-3
Sampling of materials . . . . .	4-4c	4-7	Finishing unformed surfaces . . . . .	5-3l	5-3
Data supplied by division laboratory			Sheet curing . . . . .	5-3m	5-3
to project . . . . .	4-4d	4-7	Areas to be painted . . . . .	5-3n	5-3
Adjustment of government mixture			Finishing formed surfaces . . . . .	5-3o	5-3
proportions . . . . .	4-4e	4-7	Floor tolerance . . . . .	5-3p	5-3
Evaluation of Contractor-Developed			Guide Specification "Mass Concrete,"		
Mixture Proportions . . . . .	4-5	4-8	CW-03305 . . . . .	5-4	5-3
General . . . . .	4-5a	4-8	General . . . . .	5-4a	5-3
			Sampling of aggregates . . . . .	5-4b	5-4
			Mixture proportioning studies . . . . .	5-4c	5-4
			Testing cementitious materials . . . . .	5-4d	5-4
			Surface requirements . . . . .	5-4e	5-4
			Class A finish . . . . .	5-4e(1)	5-4
			Class AHV finish . . . . .	5-4e(2)	5-4
			Class B finish . . . . .	5-4e(3)	5-4



## Table of Contents (Continued)

Subject	Paragraph	Page	Subject	Paragraph	Page
Class C finish	5-4e(4)	5-4	Air content	5-7b	5-7
Class D finish	5-4e(5)	5-4	Tolerances	5-7c	5-7
Absorptive form lining	5-4e(6)	5-4	Cement	5-7d	5-7
Appearance	5-4f	5-4	Aggregates	5-7e	5-7
Cementitious materials option	5-4g	5-4	Finishing	5-7f	5-7
Bid schedule for cementitious materials option	5-4h	5-5	Guide Specification "Preplaced Aggregate Concrete," CW-03362	5-8	5-7
Retarder	5-4i	5-5			
Water reducers	5-4j	5-5	<b>Chapter 6</b>		
Fine aggregate grading requirements	5-4k	5-5	<b>Coordination Between Design and Field Activities</b>		
Coarse aggregate grading requirements	5-4l	5-5	Bidability, Constructibility, and Operability Review	6-1	6-1
Batching and mixing plant	5-4m	5-5	General	6-1a	6-1
Type of plant	5-4m(1)	5-5	Review guidance	6-1b	6-1
Capacity	5-4m(2)	5-5	Engineering Considerations and Instructions for Construction Field Personnel	6-2	6-1
Preset mixes	5-4m(3)	5-6	General	6-2a	6-1
Mixers	5-4m(4)	5-6	Content	6-2b	6-1
Conveying and placing	5-4n	5-6	Discussion by outline heading	6-2c	6-2
Conveyance methods	5-4n(1)	5-6	Introduction	6-2c(1)	6-2
Hot-weather mixing and placing	5-4n(2)	5-6	Cementitious materials requirements or properties	6-2c(2)	6-2
Placing temperature	5-4n(3)	5-6	Aggregate requirements or properties	6-2c(3)	6-2
Lift thickness	5-4n(4)	5-6	Other materials	6-2c(4)	6-2
Placing concrete in unformed curved sections	5-4n(5)	5-6	Concrete qualities required at various locations within the structures	6-2c(5)	6-2
Concrete deposited in water	5-4n(6)	5-6	Concrete temperature-control requirements	6-2c(6)	6-3
Finishing	5-4o	5-6	Cold-weather concrete requirements	6-2c(7)	6-3
Unformed surfaces	5-4o(1)	5-6	Hot-weather concrete requirements	6-2c(8)	6-3
Formed surfaces	5-4o(2)	5-6	Contractor quality control and quality government assurance	6-2c(9)	6-3
Insulation and special protection	5-4o(3)	5-6	Critical concrete placement requirements	6-2c(10)	6-3
Areas to be painted	5-4p	5-6	Architectural requirements	6-2c(11)	6-3
Setting of base plates and bearing plates	5-4q	5-6	Finish requirements	6-2c(12)	6-3
Measurement and payment	5-4r	5-7			
Guide Specification "Formwork for Concrete," CW-03101	5-5	5-7	<b>Chapter 7</b>		
General	5-5a	5-7	<b>Preparation for Construction</b>		
Shop drawings	5-5b	5-7	Materials Acceptance Testing	7-1	7-1
Sample panels	5-5c	5-7	General	7-1a	7-1
Forms	5-5d	5-7	Cement, pozzolan, and GGBF slag	7-1b	7-1
Form removal	5-5e	5-7	Chemical admixtures	7-1c	7-1
Guide Specification "Expansion, Contraction, and Construction Joints in Concrete," CW-03150	5-6	5-7	Test of air-entraining admixtures	7-1c(1)	7-1
General	5-6a	5-7			
Cost of testing	5-6b	5-7			
Guide Specification "Precast Prestressed Concrete," CW-03425	5-7	5-7			
General	5-7a	5-7			

Table of Contents (Continued)

Subject	Paragraph	Page	Subject	Paragraph	Page
Test of other chemical admixtures . . . . .	7-1c(2)	7-2	Types of materials . . . . .	8-1a	8-1
Tests of accelerators . . . . .	7-1c(3)	7-2	Quality verification . . . . .	8-1b	8-1
Aggregates - listed source . . . . .	7-1d	7-2	Form coating . . . . .	8-1c	8-1
Aggregates - nonlisted source . . . . .	7-1e	7-2	Placing . . . . .	8-2	8-1
Aggregates - minor concrete jobs . . . . .	7-1f	7-2	General . . . . .	8-2a	8-1
Mixture Proportioning . . . . .	7-2	7-2	Bedding mortar on rock foundations . . . . .	8-2b	8-1
Concrete Plant and Materials . . . . .	7-3	7-3	Mass concrete . . . . .	8-2c	8-1
Review of concrete plant drawings . . . . .	7-3a	7-3	Structural concrete . . . . .	8-2d	8-2
Estimating plant capacity . . . . .	7-3b	7-3	Tunnel linings . . . . .	8-2e	8-2
Aggregate storage, reclaiming, washing, and rescreening . . . . .	7-3c	7-3	Inverts . . . . .	8-2e(1)	8-2
Concrete cooling plant capacity . . . . .	7-3d	7-4	Sidewalls and crown . . . . .	8-2e(2)	8-2
Batching and Mixing Equipment . . . . .	7-4	7-4	Consolidation . . . . .	8-2f	8-2
Checking compliance with specification requirements . . . . .	7-4a	7-4	Protection of waterstops . . . . .	8-2g	8-2
Scale checks . . . . .	7-4b	7-4	Finishing . . . . .	8-3	8-2
Mixer blades and paddles . . . . .	7-4c	7-4	Formed surfaces . . . . .	8-3a	8-2
Recorders . . . . .	7-4d	7-4	Unformed surfaces . . . . .	8-3b	8-3
Batching sequence . . . . .	7-4e	7-4	Ogee crest . . . . .	8-3b(1)	8-3
Mixer performance and mixing time . . . . .	7-4f	7-4	Spillway aprons . . . . .	8-3b(2)	8-3
Conveying Concrete . . . . .	7-5	7-5	Trapezoidal channel lining . . . . .	8-3b(3)	8-3
General . . . . .	7-5a	7-5	Surfaces exposed to high-velocity flow of water . . . . .	8-3b(4)	8-3
Buckets . . . . .	7-5b	7-5	Floors . . . . .	8-3b(5)	8-4
Truck mixers and agitators . . . . .	7-5c	7-5	Tolerance requirements for surface finish . . . . .	8-3c	8-4
Nonagitator equipment . . . . .	7-5d	7-5	General . . . . .	8-3c(1)	8-4
Positive-displacement pump . . . . .	7-5e	7-5	Control surface tolerance by straightedge . . . . .	8-3c(2)	8-4
Belts . . . . .	7-5f	7-5	Control floor tolerance by F-number system . . . . .	8-3c(3)	8-4
Chutes . . . . .	7-5g	7-5	Curing . . . . .	8-4	8-5
Preparation for Placing . . . . .	7-6	7-6	General . . . . .	8-4a	8-5
General . . . . .	7-6a	7-6	Moist curing . . . . .	8-4b	8-5
Earth foundations . . . . .	7-6b	7-6	Membrane curing . . . . .	8-4c	8-5
Rock foundations . . . . .	7-6c	7-6	Sheet curing . . . . .	8-4d	8-5
Cleanup of concrete surfaces . . . . .	7-6d	7-6	Cold-Weather Concreting . . . . .	8-5	8-6
Placing equipment . . . . .	7-6e	7-6	General . . . . .	8-5a	8-6
Vibrators . . . . .	7-6e(1)	7-6	Planning . . . . .	8-5b	8-6
Cold-weather and hot-weather protection equipment . . . . .	7-6e(2)	7-6	Protection system . . . . .	8-5c	8-6
Communication equipment . . . . .	7-6e(3)	7-6	Curing . . . . .	8-5d	8-6
Other equipment . . . . .	7-6e(4)	7-7	Accelerating early strength . . . . .	8-5e	8-7
Forms . . . . .	7-6f	7-7	Hot-Weather Concreting . . . . .	8-6	8-7
Curing and protection . . . . .	7-6g	7-7	General . . . . .	8-6a	8-7
Approval . . . . .	7-6h	7-7	Planning . . . . .	8-6b	8-7
Interim slabs on grade . . . . .	7-6i	7-7	Alleviating measures . . . . .	8-6c	8-7
			Placing temperature . . . . .	8-6d	8-8
			Plastic-shrinkage cracks . . . . .	8-6e	8-8
			Effect on strength and durability . . . . .	8-6f	8-8
			Cooling . . . . .	8-6g	8-9
			Curing . . . . .	8-6h	8-9
<b>Chapter 8</b>					
<b>Concrete Construction</b>					
Forms . . . . .	8-1	8-1			

Table of Contents (Continued)

Subject	Paragraph	Page	Subject	Paragraph	Page
<b>Chapter 9</b>			<b>Chapter 10</b>		
<b>Concrete Quality Verification and Testing</b>			<b>Special Concretes</b>		
Quality verification	9-1	9-1	General	10-1	10-1
General	9-1a	9-1	Preplaced-Aggregate Concrete	10-2	10-1
Government quality assurance	9-1b	9-1	General	10-2a	10-1
Quality assurance representative	9-1b(1)	9-1	Applications	10-2b	10-1
Testing technicians	9-1b(2)	9-1	Materials and proportioning	10-2c	10-1
Organization	9-1b(3)	9-2	Preplacing aggregate	10-2d	10-2
Records	9-1b(4)	9-2	Contaminated water	10-2e	10-2
Required Sampling and Testing			Preparation of underwater		
for CQC and GQC	9-2	9-3	foundations	10-2f	10-2
Aggregate grading	9-2a	9-3	Pumping	10-2g	10-2
Frequency	9-2a(1)	9-3	Joint construction	10-2h	10-2
Size of samples	9-2a(2)	9-3	Grouting procedure	10-2i	10-3
Aggregate quality - large project	9-2b	9-4	Horizontal layer	10-2i(1)	10-3
Free moisture on aggregates	9-2c	9-4	Advancing slope	10-2i(2)	10-3
Slump and air content	9-2d	9-4	Grout insert pipes and sounding		
Concrete temperature	9-2e	9-4	devices	10-2i(3)	10-3
Compressive strength	9-2f	9-4	Finishing unformed surfaces	10-2j	10-3
Purpose	9-2f(1)	9-4	Underwater Concrete	10-3	10-3
Testing responsibility	9-2f(2)	9-5	General	10-3a	10-3
Sampling plan	9-2f(3)	9-5	Tremie concrete	10-3b	10-4
Frequency and testing age	9-2f(4)	9-5	Pumped concrete for use		
Sampling and testing methods	9-2f(5)	9-5	underwater	10-3c	10-4
Analysis of tests	9-2f(6)	9-5	Blockout Concrete	10-4	10-5
Control criteria	9-2f(7)	9-6	General	10-4a	10-5
Prediction of later age strengths	9-2f(8)	9-6	Blockout concrete proportions	10-4b	10-5
Nondestructive Testing	9-3	9-7	High-Strength Concrete	10-5	10-5
General	9-3a	9-7	General	10-5a	10-5
Policy	9-3b	9-7	Definition	10-5b	10-5
Applicability	9-3c	9-7	Materials	10-5c	10-5
Nondestructive testing methods	9-3d	9-7	Cement type	10-5d	10-5
Rebound hammer	9-3d(1)	9-7	Cement content	10-5e	10-6
Penetration resistance	9-3d(2)	9-7	Aggregates	10-5f	10-6
Cast-in-place pullout tests	9-3d(3)	9-8	Pozzolans	10-5g	10-6
Maturity method	9-3d(4)	9-8	Use of HRWRA	10-5h	10-6
Cores	9-3d(5)	9-8	Workability	10-5i	10-6
Pulse velocity method	9-3d(6)	9-8	Proportioning	10-5j	10-6
Other methods	9-3d(7)	9-9	Material handling	10-5k	10-6
Preplacement Quality Verification	9-4	9-9	Preparation for placing	10-5l	10-7
Project Laboratory	9-5	9-9	Curing	10-5m	10-7
General	9-5a	9-9	Testing	10-5n	10-7
Space requirements	9-5b	9-9	Pumped Concrete	10-6	10-7
Large-volume project	9-5b(1)	9-9	General	10-6a	10-7
Other	9-5b(2)	9-9	Pump lines	10-6b	10-7
Equipment	9-5c	9-9	Mixture proportions	10-6c	10-7
Large-volume project	9-5c(1)	9-9	Coarse aggregates	10-6d	10-7
Other	9-5c(2)	9-10			

Table of Contents (Continued)

Subject	Paragraph	Page	Subject	Paragraph	Page
Fine aggregates	10-6e	10-8	<b>Chapter 11</b>		
Slump	10-6f	10-8	<b>Concrete Report</b>		
Admixtures	10-6g	10-8	General	11-1	11-1
Pumpability tests	10-6h	10-8	Policy	11-1a	11-1
Planning	10-6i	10-8	Author	11-1b	11-1
Other requirements	10-6j	10-8	Timing	11-1c	11-1
Quality verification	10-6k	10-8	Content	11-2	11-1
Fiber-Reinforced Concrete	10-7	10-9	Outline	11-2a	11-1
General	10-7a	10-9	Detailed instruction	11-2b	11-1
Advantages and limitations	10-7b	10-9	Introduction	11-2b(1)	11-1
Toughness	10-7c	10-9	Aggregate sources	11-2b(2)	11-1
Performance characteristics	10-7d	10-9	Aggregate production	11-2b(3)	11-1
Mixture proportioning	10-7e	10-9	Cementitious materials	11-2b(4)	11-4
Batching and mixing	10-7f	10-9	Chemical admixtures	11-2b(5)	11-4
Placement	10-7g	10-10	Concrete batching and mixing		
Workability	10-7h	10-10	plant	11-2b(6)	11-4
Pumping	10-7i	10-10	Concrete mixtures used	11-2b(7)	11-4
Other fibers	10-7j	10-10	Equipment and techniques	11-2b(8)	11-4
Effects of polypropylene fibers			Concrete transportation and		
on workability	10-7k	10-10	placement	11-2b(9)	11-4
Use of polypropylene fibers	10-7l	10-10	Concrete curing and protection	11-2b(10)	11-4
Porous Concrete	10-8	10-10	Temperature control	11-2b(11)	11-4
General	10-8a	10-10	Special concretes	11-2b(12)	11-4
Types	10-8b	10-10	Precast concrete	11-2b(13)	11-4
Composition	10-8c	10-11	Quality verification and testing	11-2b(14)	11-4
W/C considerations	10-8d	10-11	Summary of test data	11-2b(15)	11-4
Durability	10-8e	10-11	Special problems	11-2b(16)	11-5
Percent voids	10-8f	10-11			
Proportioning porous concrete			<b>Appendix A</b>		
mixtures	10-8g	10-11	<b>References</b>		
Placement	10-8h	10-11	<b>Appendix B</b>		
Flowing Concrete	10-9	10-11	<b>Abbreviations</b>		
General	10-9a	10-11	<b>Appendix C</b>		
HRWRA	10-9b	10-12	<b>Concrete Materials Design Memorandum</b>		
Proportioning flowing concrete	10-9c	10-12	<b>Appendix D</b>		
Flowing concrete fresh properties	10-9d	10-12	<b>Alkali-Silica Aggregate Reactions</b>		
Flowing concrete hardened			<b>Appendix E</b>		
properties	10-9e	10-12	<b>Alkali-Carbonate Rock Reactions</b>		
Silica-Fume Concrete	10-10	10-12			
General	10-10a	10-12			
Properties of silica fume	10-10b	10-12			
Effect on water demand and					
bleeding	10-10c	10-12			
Effect on cohesiveness	10-10d	10-13			
Effect on air entrainment	10-10e	10-13			
Effect on plastic shrinkage	10-10f	10-13			
Effect on strength and modulus					
of elasticity	10-10g	10-13			
Effect on permeability and durability	10-10h	10-13			

## Chapter 1 Introduction

### 1-1. Purpose

The purpose of this manual is to provide information and guidance for the investigation and selection of concrete materials for civil works concrete structures. Elements discussed include design studies and reports, preparation of contract plans and specifications, construction preparation, and concrete construction quality verification. Emphasis is placed on the problems of concrete for hydraulic structures. Roller-compacted concrete, shotcrete, rigid pavements, architectural concrete, and concrete for repairs are not included. These subjects are discussed in EM 1110-2-2006, Roller-Compacted Concrete; EM 1110-2-2005, Standard Practice for Shotcrete; TM 5-822-7, Standard Practice for Concrete Pavements; EM 1110-1-2009, Architectural Concrete; and EM 1110-2-2002, Evaluation and Repair of Concrete Structures, respectively.

### 1-2. Applicability

This manual is applicable to all HQUSACE elements, major subordinate commands, districts, laboratories, and field operating activities having civil works responsibilities.

### 1-3. References

Applicable references are listed in Appendix A. The most current versions of all references listed in paragraphs A-1 and A-2 should be maintained in all districts and divisions having civil works responsibilities. The references should be maintained in a location readily accessible to those persons assigned the responsibility for concrete materials investigations and concrete construction. Terms used in this document are defined in ACI 116R.

### 1-4. Explanation of Abbreviations

Abbreviations used in this manual are explained in Appendix B.

### 1-5. Engineering Responsibilities and Requirements

This paragraph outlines the concrete-related engineering responsibilities and requirements during the development of a civil works project. A summary of these engineering requirements is presented in Table 1-1. Deviations from the requirements described in this paragraph are possible, and

such an option as progression from a feasibility report directly to plans and specifications may be permissible. Requests for exceptions or deviations should be made in accordance with ER 1110-2-1150.

*a. Reconnaissance phase.* Concrete investigation is generally not required during the reconnaissance phase. However, the engineering effort and budget required for concrete investigation during the feasibility phase should be identified and included in the Feasibility Cost-Sharing Agreement (FCSA).

*b. Feasibility phase.* During the feasibility phase, a preliminary investigation, in accordance with the requirements given in Chapter 2, should be conducted to determine the potential sources and suitability of concrete materials. The engineering effort during this phase should be sufficient so that the baseline cost estimate with reasonable contingency factors for concrete materials can be developed. The potential sources and suitability of concrete materials for the project should be documented in the engineering appendix to the feasibility report (or in a general design memorandum (GDM)) in accordance with ER 1110-2-1150, Engineering and Design for Civil Works Projects. Any special studies required during the preconstruction engineering and design (PED) phase should be identified. These special studies may include, but not be limited to, thermal studies, abrasion-erosion studies, mixer grinding studies, and cavitation studies. The budget and schedules for these special studies and for the concrete report should be included in the project management plan (PMP).

*c. Preconstruction engineering and design phase.* During the PED phase and prior to the preparation of plans and specifications (P&S), a detailed engineering investigation on concrete materials, including cementitious materials, aggregates, water for mixing and curing, and chemical admixtures, should be conducted in accordance with the requirements given in Chapter 2. Concrete mixture proportioning and concrete construction procedures should be investigated in accordance with pertinent requirements in Chapters 4 and 7, respectively. The results of these investigations should be documented in a concrete/materials design memorandum (DM). The scope and format for the DM will vary depending on the quantities and criticality of concrete involved as outlined in Appendix C. Any special studies identified in the feasibility phase should be carried out during the PED. The concrete plans and specifications should be prepared in accordance with Chapter 5. For any project which includes major concrete construction, a report outlining the engineering considerations and providing

1 Feb 94

**Table 1-1**  
**Concrete-Related Engineering Responsibilities and Requirements**

Phase	Engineering Efforts	Document
Reconnaissance	Identify engineering efforts and budget required for concrete investigation during the feasibility phase	Input to FCSA
Feasibility	Preliminary investigations to determine the potential sources and suitability of concrete materials	Engineering appendix to Feasibility Report or GDM
	Identify the engineering requirements, budget, and schedules for the special studies required during PED.	Engineering appendix to Feasibility Report (or GDM) and PMP
PED	Detailed investigations on concrete materials, preliminary mixture proportioning, and concrete construction procedures	Concrete materials DM
	Perform special studies	DM or special study reports
	Prepare concrete P&S 's	P&S
	Prepare engineering considerations and instructions for field personnel	Report
Construction	Develop, adjust, or evaluate mixture proportions	
	Site visits and QV	
	Support for concrete claims and modifications	
	Prepare concrete report	Concrete Report

instruction for field personnel to aid them in the supervision and quality verification (QV) of concrete construction should be prepared in accordance with Chapter 6.

*d. Construction phase.* Engineering effort during the construction phase generally includes development, adjustment or evaluation of mixture proportions, or both, site visits and QV, support for concrete claims and modifications, and preparation of a concrete report. The concrete construction QV requirements are given in Chapter 9. The guidelines for preparing a concrete report can be found in Chapter 11.

#### **1-6. Delays in Contract Awards**

If delays of 5 years or longer occur between the time of completion of the relevant concrete materials DM and the start of construction, it will be necessary to reconfirm the validity of the findings of the DM immediately prior to the issuance of P&S's to prospective bidders. The availability of the types and sources of cementitious materials should be rechecked. If changes have occurred, it may be necessary to conduct tests to determine the suitability of the currently available cementitious materials in combination with the available aggregates and present findings in supplements to

the earlier concrete materials DM. Aggregate sources that have not been used in the period between the aggregate investigations and the preparation for the contract award may be assumed to remain acceptable. Commercial aggregates sources that have been used should be examined to verify that adequate materials remain in the pit or quarry and that the lithology has not changed as materials have

been removed. If significant changes have occurred, they should be confirmed petrographically. Depending on the results of the petrographic examination, it may be necessary to reevaluate the aggregate source for suitability. The results of such a reevaluation should be presented as a supplement to the earlier concrete materials DM.

## Chapter 2 Investigation and Selection of Materials

### 2-1. Introduction

During the investigations for a civil works structure that incorporates concrete, it is necessary to assess the availability and suitability of the materials needed to manufacture concrete with qualities meeting the structural and durability requirements. Materials involved include cementitious materials, fine aggregate, coarse aggregate, water for mixing and curing, and chemical admixtures. These investigations will result in a separate DM or a portion of a DM, in accordance with Appendix C.

### 2-2. Cementitious Materials

*a. General.* The goal of the investigation of cementitious materials should be to determine the suitability and availability of the various types of cement, pozzolan, and ground granulated blast-furnace (GGBF) slag for the structures involved and to select necessary options that may be needed with the available aggregates. In cases where types or quantities of available cementitious materials are unusually limited, it may be necessary to consider altered structural shapes, changing the types of structure, altered construction sequence, imported aggregates, or other means of achieving an economical, serviceable structure.

*b. Types.* The following types of cementitious material should be considered when selecting the materials:

(1) Portland cement. Portland cement and air-entraining portland cement are described in American Society for Testing and Materials (ASTM) C 150 (CRD-C 201).

(2) Blended hydraulic cement. The types of blended hydraulic cements are described in ASTM C 595 (CRD-C 203). ASTM Type I (PM) shall not be used; reference paragraph 4-3b(7) of this manual.

(3) Pozzolan. Coal fly ash and natural pozzolan are classified and defined in ASTM C 618 (CRD-C 255).

(4) GGBF slag. GGBF slag is described in ASTM C 989 (CRD-C 205).

\* Test methods cited in this manner are from the American Society for Testing and Materials *Annual Book of ASTM Standards* (ASTM 1992) and from *Handbook of Concrete and Cement* (U.S. Army Engineer Waterways Experiment Station (USAEWES) 1949), respectively.

(5) Other hydraulic cements.

(a) Expansive hydraulic cement. Expansive hydraulic cements are described in ASTM C 845 (CRD-C 204).

(b) Calcium-aluminate cement. Calcium-aluminate cements (also called high-alumina cement) are characterized by a rapid strength gain, high resistance to sulfate attack, resistance to acid attack, and resistance to high temperatures. However, strength is lost at mildly elevated temperatures (e.g. >85 °F) in the presence of moisture. This negative feature makes calcium-aluminate cement impractical for most construction. It is used predominantly in the manufacture of refractory materials.

(c) Proprietary high early-strength cements. Cements are available that gain strength very rapidly, sometimes reaching compressive strengths of several thousand pounds per square in. (psi) in a few hours. These cements are marketed under various brand names. They are often not widely available, and the cost is much higher than portland cement. The extremely rapid strength gain makes them particularly suitable for pavement patching.

(6) Silica fume. Silica fume is a pozzolan. It is a byproduct of silicon and ferro-silicon alloy production. Silica fume usually contains about 90 percent SiO<sub>2</sub> in microscopic particles in the range of 0.1 to 0.2 μm. These properties make it an efficient filler as well as a very reactive pozzolan. Silica fume combined with a high-range water reducer is used in very high-strength concrete. Silica fume is described in ASTM C1240 (CRD-C270). Detailed information can be found in paragraphs 2-2d(5) and 10-10.\*

(7) Air-entraining portland cement. Air-entraining portland cement is only allowed for use on structures covered by the specifications for "Concrete for Minor Structures," CW-03307. Air-entraining admixtures are used on all other Corps civil works structures since this allows the air content to be closely controlled and varied if need be.

#### *c. Selection of cementitious materials.*

(1) General. The selection of one or several suitable cementitious materials for a concrete structure depends on the exposure conditions, the type of structure, the characteristics of the aggregate, availability of the cementitious material, and the method of construction.

(2) Type of structure. The type of structure, i.e. mass or structural, provides an indication of the category of



1 Feb 94

concrete that the structure may contain. Mass concrete is defined as any volume of concrete with dimensions large enough to require that measures be taken to cope with generation of heat from hydration of the cementitious materials and attendant volume change to minimize cracking. A gravity dam and a navigation lock are examples of massive structures. Structural concrete is defined as concrete which will normally be placed in reinforced structural elements such as beams, columns, walls, and slabs that have dimensions such that heat generation is not a problem. Many features of a structure will fall between the two extremes of being either strictly massive or structural, and the designer will need to decide if measures to limit or mitigate the heat generation will be required. For example, reinforced walls and slabs of 4- to 6-ft thickness in a pumping station that contains 3,000- to 5,000-psi concrete would probably generate sufficient heat that measures should be taken to limit either the peak temperature of the concrete or the rate at which heat is lost from the concrete after the peak temperature is reached. The factors that affect the amount of heat that is generated and the peak temperature that the concrete will reach are the amount and type of cementitious materials in the concrete, the size of the placement, and the initial placing temperature.

(a) Table 2-1 lists cementitious materials that should be investigated for availability and suitability, according to the type of structure. Other more specialized cementitious materials, such as Type V portland cement or proprietary high-early strength cement, should be investigated if needed.

(b) Specification details. Type II cement is described by ASTM C 150 (CRD-C 201) as a cement for use when moderate sulfate resistance or moderate heat of hydration is desired. The heat-of-hydration part of this description requires that the 70-calorie/gram optional limit be specified. Many Type II cements evolve heat at rates comparable to those of Type I cements. The chemical requirement which is in ASTM C 150 for the purpose of limiting heats of hydration is not a satisfactory means of assuring reduced heat of hydration and should not be used. Neither Type IV portland cement nor Type P portland-pozzolan cement are generally available at the present time. Both also exhibit very low rates of strength gain. These characteristics should be addressed in the concrete materials DM prior to specifying either type. ASTM C 989 (CRD-C 205) includes a provision for three grades of GGBF slag, grade 120, which contributes to the fastest strength development, grade 100 which is an intermediate grade, and grade 80 which contributes least to strength development. However, at present, only grade 120 is available. Generally, if other grades were available, grade 80, 100, or 120 should be

considered for use in mass concrete, and grades 100 and 120 should be considered for use in structural concrete.

(3) Other requirements.

(a) General. The investigation of cementitious materials must include an assessment of the impact on cost and availability of special requirements or options. Provisions that limit the heat of hydration, provide sulfate resistance, limit the alkali content, or control false set should be invoked based on a demonstrated need for cement having these characteristics.

(b) Sulfate exposures. Precautions against the potentially harmful effects of sulfate will be specified when concrete is to be exposed to seawater or the concentration of water-soluble sulfate ( $\text{SO}_4$ ) in soil or in fresh water that will be in contact with the concrete (as determined by CRD-C 403 and 408) is greater than 0.10 percent or 150 parts per million (ppm,) respectively. Concentrations higher than these will be classified as representing *moderate* or *severe* potential exposures according to the criteria shown in Table 2-2. The precautions to be specified will vary with the availability and anticipated costs of materials and with other factors. Where moderate attack is to be resisted, moderate sulfate-resisting cement (Type II, Type III with the optional 8 percent limit on  $\text{C}_3\text{A}$  invoked, Type IP(MS), Type IS(MS), or Type P(MS)) should be specified. In seawater where no greater precautions than moderate are needed, the 8-percent limit on  $\text{C}_3\text{A}$  may be increased to 10 percent if the water-cement ratio (w/c) of the concrete is kept below 0.45 by mass and the concrete will be permanently submerged in seawater. If moderate sulfate-resisting cement is not economically available, concrete that is resistant to moderate attack may be made by using Type I cement having not more than 10 percent  $\text{C}_3\text{A}$  or Types IS or IP which contain an adequate amount of suitable Class F pozzolan or slag or to which additional Class F pozzolan or slag is added. Performance tests must be conducted to determine the suitability of any substitutes for sulfate-resistant cement. If straight portland cement is proposed, the test method is described in ASTM C 452 (CRD-C 232). If a blend of portland cement and pozzolan or a blended hydraulic cement is proposed, the test method is ASTM C 1012 (CRD-C 211). Where severe attack is to be resisted, highly sulfate-resistant cement (Type V, Type III with 5 percent limit on  $\text{C}_3\text{A}$ ) should be specified and used unless problems of cost or availability are encountered, in which case other materials as outlined above should be taken. Additional information may be obtained from American Concrete Institute (ACI) 201.2R.

**Table 2-1**  
**Guide for Selection of Cementitious Materials According to Type Structure**

Cementitious Material	Mass Concrete	Structural Concrete
Portland cement:		
Type I		X
Type II	X	X
Type II with heat of hydration 70 cal/g or less	X	X
Type I with pozzolan		X
Type II with pozzolan	X	X
Type I with GGBF slag		X
Type II with GGBF slag	X	X
Type III		X
Type IV	X	
Blended hydraulic cements:		
Type IS(MH)	X	X
Type IS		X
Type IP(MH)	X	X
Type IP		X
Type P	X	
Type P(LH)	X	
Type I(SM)		X
Type I(SM), (MH)	X	
Type S, with Type I or Type II Portland cement	X	

**Table 2-2**  
**Guide for Determining Sulfate Exposure Condition**

Exposure condition	SO <sub>4</sub> concentration, Fresh water	SO <sub>4</sub> concentration, Soil, %
Moderate	150 - 1,500 ppm	0.10 - 0.20
Severe	>1,500 ppm	>0.20

(c) False set. False set is one type of the abnormal premature stiffening of cement within a few minutes of mixing with water. Remixing of the concrete after a few minutes of maintaining the mixer at rest or a longer initial mixing time will restore the plasticity of the mixture, and it will then set and gain strength normally. False set normally does not occur when ready-mix trucks are used to transport concrete because of the length of the mixing cycle. When such lengthy mixing or a remix step, as described above, is impractical, then the optional requirement limiting false set in ASTM C 150 (CRD-C 201) should be invoked. When premature stiffening cannot be overcome by additional mixing, it is probably "flash set" due to inadequate retardation of the cement during manufacture.

(d) Cement-admixture interaction. Some cement-admixture combinations show no tendency to cause early stiffening when tested according to ASTM C 451 (CRD-C 259) but will cause early stiffening when used with some water-reducing admixtures. The phenomenon can be detected by testing the cement and admixture proposed for use according to ASTM C 451. Also see paragraph 2-5 on chemical admixtures.

(e) Alkali reactivity. The potential for deleterious reactivity of the alkalis in the cement with the aggregate should be evaluated as outlined in Appendixes D and E of this manual. If the aggregates are potentially reactive, paragraph D-6 presents options, including disapproval of the aggregate source, use of low-alkali cements, or use of GGBF slag or pozzolans.

(f) Heat of hydration. The heat of hydration should be limited in those cases where thermal strains induced on cooling of the concrete are likely to exceed the strain capacity of the concrete in the structure. This is accomplished by specifying the available option for limiting the heat of hydration for Type II portland cement or using Type IV cement, if available. For blended hydraulic cements, the heat of hydration is limited by specifying the suffix (MH) for Type IS, I(SM), IP, S, and (LH) for Type P. The replacement of a portion of the portland cement or in some cases blended hydraulic cement with a pozzolan or GGBF slag should always be considered. The heat generation of each proposed cement type and each combination of cement and pozzolan or slag should be determined. The amount of heat generated should be equal to or less than the amount generated by the Type II with heat-of-hydration option which is also normally specified.

(4) Requirements for use of other hydraulic cements.

(a) Expansive hydraulic cement. Expansive cements have been used in floor slabs, in the top lifts of some lock walls, and in the lining slab of spillway channels to reduce shrinkage cracking. The applications have generally been accomplished in closely controlled situations and after extensive investigation. Additional reinforcement is usually required to control the expansion. Since the use of expansive cements in water-control structures is far from common, its proposed use will require a comprehensive investigation to be included in the concrete-materials DM.

(b) High-alumina cement. High-alumina cement is not normally used in civil works structures and should be considered only in those locations which justify its added cost and after investigating the possible effects of its tendency to lose strength when exposed to heat and moisture. Its use should be preceded by a comprehensive investigation which is made a part of the concrete materials DM.

(c) Proprietary high early-strength cements. Cements that develop high strength within a few hours are often considered for use in cold weather applications or for repair applications, or both, that are required to bear load soon after finishing. The investigation that precedes its use should determine availability and the characteristics of the available material. The results of the investigation should be included in the concrete materials DM.

(5) Pozzolans. The classes of pozzolans most likely to be available are classes F and C fly ash and silica fume. Class N may be considered at those sites where a source of natural pozzolan is available.

(a) Regulations governing use of fly ash. The Solid Waste Disposal Act, Section 6002, as amended by the Resource Conservation and Recovery Act of 1976, requires all agencies using Federal funds in construction to allow the use of fly ash in the concrete unless such use can be shown to be technically improper. The basis of this regulation is both energy savings and waste disposal, since most fly ash in use today is the result of the burning of coal for electrical power.

(b) General. The use of pozzolan should be considered coincident with the consideration of the types of available cements. Portland cement to be used alone should always be considered in the specifications as well as blended hydraulic cements or the combination of portland cement with slag cement or pozzolan unless one or the latter is determined to be technically improper. Classes F and C

fly ash are generally accepted on all Corps of Engineers' (CE) civil works projects, and their use should be allowed in all specifications unless there are technical reasons not to do so.

(c) Class F pozzolan. Class F pozzolan is a fly ash usually obtained from burning anthracite or bituminous coal and is the class of fly ash that has been most commonly used to date. It must contain at least 70.0 percent of  $\text{SiO}_2 + \text{Al}_2\text{O}_3 + \text{Fe}_2\text{O}_3$  by chemical analysis.

(d) Class C pozzolan. Class C pozzolan is a fly ash that is usually obtained from the burning of lignite or subbituminous coal. It must contain at least 50.0 percent of  $\text{SiO}_2 + \text{Al}_2\text{O}_3 + \text{Fe}_2\text{O}_3$ .

(e) Other considerations. Class C fly ashes often contain considerably more alkalis than do Class F fly ashes. However, when use of either class in applications where alkali-aggregate reaction is likely, the optional available alkali requirement of ASTM C 618 (CRD-C 255) should be specified. Use of Class F fly ash in replacement of portland cement results in reduction of heat of hydration of the cementitious materials at early ages. Use of Class C fly ash in the same proportions usually results in substantially less reduction in heat of hydration. An analysis of the importance of this effect should be made if Class C fly ash is being considered for use in a mass concrete application. See paragraph 3-2b, "Thermal Studies." Class F fly ash generally increases resistance to sulfate attack. However, if the portland cement is of high  $\text{C}_3\text{A}$  content, the amount of improvement may not be sufficient so that the combined cementitious materials are equivalent to a Type II or a Type V portland cement. This can be determined by testing according to ASTM C 1012 (CRD-C 211). Class C fly ashes are quite variable in their performance in sulfate environments, and their performance should always be verified by testing with the portland cement intended for use. Both Class F and Class C fly ashes have been found to delay for initial and final set. This retarding action should be taken into consideration if important to the structure. Most Class C and Class F fly ashes are capable of reducing the expansion from the alkali-silica reaction. Use of an effective fly ash may eliminate the need to specify low-alkali cement when a reactive aggregate is used. The effectiveness of the fly ash must be verified by ASTM C 441 (CRD-C 257). For additional information, see Appendixes D and E.

(f) Class N pozzolan. Class N is raw or calcined natural pozzolans such as some diatomaceous earths, opaline cherts, tuffs, and volcanic ashes such as pumicite.

(g) Silica fume. Silica fume is a pozzolan. It is a byproduct of the manufacture of silicon or silicon alloys. The material is considerably more expensive than other pozzolans. Properties of silica fume vary with the type of silicon or silicon alloy produced, but in general, a silica fume is a very finely divided product and consequently is used in concrete in different proportions and for different applications than are the more conventional pozzolans discussed in the previous paragraphs. Applications for which silica fume is used are in the production of concrete having very high strengths, high abrasion resistance, very low permeability, and increased aggregate bond strength. However, certain precautions should be taken when specifying silica-fume concretes. Use of silica fume produces a sticky paste and an increased water demand for equal slump. These characteristics are normally counteracted by using high-range water-reducing admixtures (HRWRA) to achieve the required slump. This combination, together with an air-entraining admixture, may cause a coarse air-void system. The higher water demand for silica-fume concrete greatly reduces or eliminates bleeding, which in turn tends to increase the likelihood of plastic shrinkage cracking. Therefore, steps should be taken as early as possible to minimize moisture loss, and the curing period should be increased over that required for conventional concrete. For additional information, see paragraph 10-10i.

*d. Availability investigation of cementitious materials.*

(1) General. Following the investigation outlined previously in paragraph 2-1c to determine the technical requirements of the cementitious materials for a project, it is necessary to assess availability of those materials in the project area. Technical requirements to use a certain type or kind of cementitious material to assure long-term durability and serviceability of the structure shall not be compromised because of the cost of obtaining the material. All cementitious materials should be furnished by the Contractor. The contract specifications should allow the Contractor maximum flexibility to provide cementitious materials that meet the technical requirements for the project. The investigation should cover an area sufficient to provide at least two sources of each cementitious material to provide price competition. An estimate of the cost per ton of each material delivered to the project should be secured from each producer. The key objective of the availability investigation is to ensure that materials meeting the technical requirements can be obtained by the Contractor.

(2) Portland cement and blended hydraulic cements. The availability of the technically acceptable portland

cement and blended hydraulic cement types must be investigated prior to listing materials in the DM or the contract specifications. Any optional physical or chemical requirements from ASTM C 150 (CRD-C 201) or ASTM C 595 (CRD-C 203) that are to be invoked by the designer must be considered during the investigation. For example, Type II cement or Type IP blended hydraulic cement may be readily available in the project area, but when the heat-of-hydration option is invoked from ASTM C 150 for portland cement or from ASTM C 595 for blended hydraulic cement, the availability may be severely reduced. Producers in the project area should be queried about their current production and also about their ability and willingness to produce material that meets any optional physical or chemical requirements that the designer deems necessary.

(3) Pozzolans. The availability of technically acceptable pozzolans, both natural pozzolans and fly ashes, must be investigated prior to listing materials in the contract specifications. Normally, only commercial sources of natural pozzolan and fly ash that are economically viable for use on the project will need to be investigated. Undeveloped sources of natural pozzolans should not be investigated unless there are no other sources of pozzolan available. CECW-EG should be contacted for guidance in evaluating an undeveloped source of natural pozzolan. The availability investigation should include any optional chemical or physical options from ASTM 618 (CRD-C 255) that the designer needs to invoke for technical reasons. Producers in the project area should be queried about their production and material properties and also about their ability and willingness to produce material that meets any optional requirements that the designer deems necessary. It should be stressed that the uniformity requirement in ASTM 618 will be required.

(4) GGBF slag. The availability of technically acceptable GGBF slag must be investigated prior to listing it in the contract specifications. Availability is presently limited and only Grade 120 material is being produced. GGBF slag must meet the requirements of ASTM C 989 (CRD-C 205).

(5) Silica fume. Silica fume is generally available only from national distributors as a proprietary material. It is a relatively expensive material. Therefore, it is rarely used in mass concrete structures but more likely in structural concrete and shotcrete applications. When specifying silica fume, the optional requirement of specific surface area in ASTM C 1240 Table 4 should be invoked in all cases. The optional Table 2 in ASTM C 1240 should be used only if low alkali cement is required. The uniformity requirement

in Table 4 should be invoked when concrete is air-entrained. The sulfate resistance expansion requirement in Table 4 need not be included except in areas where sulfate attack is expected. All other optional requirements in Table 4 need not be specified unless past experiences or environment conditions justify these tests. \*

### 2-3. Aggregates

*a. General.* One of the most important factors in establishing the quality and economy of concrete is a determination of the quality and quantity of aggregates available to the project. Preliminary investigation to determine potential aggregate sources should be performed during the feasibility phase, and detailed investigations should be performed during the PED prior to issuance of P&S's. All sources investigated during the PED should be documented in the appropriate DM, and those sources found capable of producing aggregates of suitable quality should be listed for the Contractor's information in the specifications. Ideally, the sources investigated should be within a few miles of the project; however, depending on the quality of aggregates required and the availability of transportation, aggregates may be transported a considerable distance. Not all sources within a certain distance of a project need be investigated, but representative sources from various kinds of sources in the vicinity must be evaluated to establish the quality of aggregates that can be produced. The investigation should be comprehensive enough to assure that more than one source of each aggregate type and size is available to the Contractor. The decision of whether or not to investigate a potential source should not be based on the grading of materials currently stockpiled at the source but should be based on determining the quality of the aggregate from the source or formation. The Contractor/producer should be given the opportunity during construction to adjust his processing to meet the grading specified. The investigation will result in a list of aggregate qualities that are required for the project and an acceptance limit for each quality. The aggregate qualities and their respective limits must be documented in a DM and will be used in preparation of specifications for the project.

(1) Sources of aggregate (Government or commercial). The decision to investigate a Government source or only commercial sources is based on appraisal of the economic feasibility of an onsite source when compared to commercial sources that contain aggregate of adequate quality and that are within economic hauling distance of the project. The appraisal should also consider the environmental consequences of opening and restoring the Government site.

If a Government source is investigated, it will be owned or controlled by the Government and will be made available to the Contractor for the production of aggregate. The presence of a Government source does not preclude the investigation of commercial sources that appear to be economically feasible. All sources investigated will be documented in the appropriate DM.

(2) Minor structures. For minor structural projects, the source of aggregate need not be listed since a quality requirement is specified by reference to ASTM C 33 (CRD-C 133). Before specifications are issued, the availability of aggregate meeting these requirements should be determined. If none are economically available to the project, then the specifications should be altered to allow the use of the specification under which most of the satisfactory aggregate in the area is produced, whether that be a state or local specification.

*b. Availability investigation.*

(1) General. The objectives of the availability investigation are to determine the required aggregate quality for the project, the quality of the aggregate available to the project, and that sufficient quantity of the required quality is available. The required aggregate quality is stated in the appropriate DM as a list of aggregate properties and their respective acceptance test limits. Preliminary investigations to determine the potential sources and the required aggregate quality shall be performed during the feasibility phase and the results documented in the engineering appendix to the feasibility report. During the PED, field explorations and sampling and testing of aggregates should be initiated based on the work previously completed in the feasibility report. This activity should be continued with an increasingly expanded scope through the completion of the concrete materials DM. If satisfactory Technical Memorandum No. 6-370, "Test Data, Concrete Aggregates and Riprap Stone in Continental United States and Alaska" (USAEWES 1953), data are available and less than 5 years old, it will not be necessary to repeat the sampling and testing of those sources for which such data are available. See Appendix C for further guidance on the scope of the investigation.

(2) Service records. Service records can be of great value in establishing the quality of an aggregate where reliable information on the materials used to produce the in situ concrete, construction procedures, and job control are available. The service record must be of sufficient time to assure that possible deleterious processes have had time to manifest themselves and the existing structure must be in the same environment that the proposed structure will be

subjected to. Photographs should be used to document the condition of the in situ concrete.

(3) Field exploration and sampling of undeveloped sources. In undeveloped potential quarries, field explorations should consist of a general pattern of core borings arranged to reveal the characteristic variations and quality of material within the deposit. Representative portions of the cores should be logged in detail and should be selected for laboratory testing in accordance with CRD-C 100. In addition to the small holes, large calyx drill holes should be used to obtain large samples for processing into aggregate similar to that required for the project, unless a test quarry or test pit is to be opened. Additional information on the exploration of undeveloped quarry sources is available in EM 1110-1-1804, "Geotechnical Investigations," and EM 1110-2-2302, "Construction with Large Stone," and these references should be consulted prior to undertaking an investigation. During PED, for a source of crushed stone for a large project, a test quarry should be opened and samples tested to assure that the required quality is available. In the case of undeveloped alluvial deposits, explorations should consist of a sufficient number of test pits, trenches, and holes to indicate characteristic variations in quality and quantity of material in the deposit. Grading of materials in alluvial deposits should be determined to establish grading trends within the deposits. Representative samples of materials should be selected for laboratory testing in accordance with CRD-C 100. Procedures for making subsurface explorations are described in EM 1110-1-1804, "Geotechnical Investigations."

(4) Field exploration and sampling of developed sources. In commercial sources, a thorough geologic evaluation should be made of the deposit from which the raw materials are being obtained to determine the extent of the deposit and whether or not material remaining in the deposit may be expected to be essentially the same as that recovered from the source at the time of the examinations. In quarries and mines, working faces should be examined, logged, sampled, photographed, and when considered necessary, mapped. When available, results of and samples from subsurface explorations performed by the owner should be examined and evaluated. Where no subsurface information is available and proper appraisal cannot be made without it, arrangements should be made with the owner to conduct the necessary subsurface explorations. The primary source of samples for quality evaluation testing should be from material produced at the time of the investigation. These samples should be supplemented by samples from working faces and subsurface explorations. All samples should be taken in accordance with CRD-C 100.

(5) Testing potential aggregate sources. During the PED phase, there should be sufficient testing to define the quality of aggregates available within an economic hauling distance of the project. The sampling and testing program should be designed to evaluate geologic formations, deposits, strata, or rock type available to the project. It is not necessary to sample and test all producers within the economic hauling distance of the project.

(6) Evaluating aggregate qualities.

(a) Significance of test results. Aggregate quality cannot be measured by fixed numbers from laboratory test results only. These results should be used as indicators of quality rather than as positive numerical measures of quality. An aggregate may still be considered acceptable for a given project even though a portion of the test results fall outside the conventional limits found in reference standards such as ASTM C 33 (CRD-C 133). Results of individual tests should be considered and the final judgment should be based on overall performance, including service records where available. The cost of obtaining aggregates of the quality necessary to assure durability during the life of the project should not be a factor in establishing the required quality. The incremental cost of obtaining quality aggregates during initial construction is always less than the cost of repairs if concrete deteriorates during the service life of the project due to aggregate deficiencies. Detailed discussions of the interpretation of aggregate test data can be found in ACI 221R and EM 1110-2-2302, "Construction with Large Stone." See also the discussion in paragraph 2-3b(9)(b), "Acceptance Criteria."

(b) Petrographic examination (ASTM C 295 (CRD-C 127)). Results of a petrographic examination should be used both for assessing the suitability of materials and for determining what laboratory tests may be necessary to evaluate the suitability of materials for use as concrete aggregate. Petrographic examination is performed for two purposes: (1) lithologic and mineralogic identification and classification and (2) determination of composition, physical, and chemical characteristics. From this examination, a description of material should be written and a preliminary estimate of the general quality of the material should be made. It is possible to identify the presence of constituents that are capable of reacting with the alkalis in cement from petrographic examination. When such constituents are identified, other investigations, including the Quick Chemical Test (ASTM C 289 (CRD-C 128)) or Mortar-Bar Test (ASTM C 227 (CRD-C 123)), or both, should be performed to determine their potential reactive effects. Table 2-3 lists the testing property, testing method, and comments regarding the testing.

(c) Specific gravity (ASTM C 127; ASTM C 128). Specific gravity of aggregates is necessary for calculating the mass for a desired volume of material. It has no clearly defined significance as a measure of suitability of material for use as concrete aggregate. Aggregates with specific gravity below 2.4 are usually suspected of being potentially unsound and, thus, not suited for use in the exposed portions of hydraulic structures in moderate-to-severe exposures. However, these materials may still be used if their performance in freezing-and-thawing tests is acceptable. Low specific gravity has been indicative of poor quality in porous chert gravel aggregates having high absorption. Therefore, it may be necessary to set a limit on the permissible amount of material lighter than a given specific gravity when selecting chert gravel aggregates for use in hydraulic structures in moderate or severe environment. The specific gravity limit and the permissible amount lighter than the limit should be established on the basis of results of laboratory freezing-and-thawing tests.

(d) Absorption (ASTM C 127; ASTM C 128). Absorption is determined primarily as an aid in estimating amounts of water in aggregates for laboratory and field control of amount of mixing water used in the concrete. Absorption data are generally believed to be somewhat indicative of the probable influence of aggregates on the durability of concrete exposed to freezing and thawing when subject to critical saturation. However, test results have indicated that this premise must be used with caution in assessing the quality of material. High absorption in aggregates may be an indication of potential high shrinkage in concrete and may need further investigation. However, absorption alone should not be considered significant as a measure of suitability of a material for use as concrete aggregate.

(e) Organic impurities (ASTM C 87; ASTM C 40). The test for presence of organic impurities should be used primarily as warning that objectionable amounts of organic impurities may be present in the aggregates. Objectional amounts of organic matter will usually show "darker than No. 3" in the ASTM C 40 test. Primary dependence should be placed on the mortar strength tests as a basis for judging whether or not objectionable amounts of organic impurities are present in natural fine aggregate. Natural fine aggregate showing the presence of organic matter and producing mortar strength of less than 95 percent of those produced by the same aggregate after washing with sodium hydroxide to remove organic matter should not be selected for use unless it is evident that the material can be adequately processed to remove impurities.

**Table 2-3**  
**Standard Procedures for Obtaining Information on Aggregate Quality**  
**During the Preconstruction Engineering and Design Phase**

Testing Property	Testing Method*	Comments
Composition and identification	ASTM C 295	This petrographic examination is recommended for all aggregate evaluation and should be the basis for the determination of other procedures required.
Specific gravity and absorption	ASTM C 127 ASTM C 128	Density will affect the density of concrete. In general, higher absorption of coarse aggregate may indicate less F/T resistance (CRD-C 107 and 108, respectively).
Organic impurities	ASTM C 40 ASTM C 87	Too much impurity will affect the concrete strength. ASTM C 87 (CRD-C 116) should be performed if there are objectionable amounts of organic impurities (CRD-C 121 and 116, respectively).
Soft constituents	CRD-C 141 CRD-C 130	Soft materials in fine aggregate will affect concrete strength and workability. Soft particles in coarse aggregate will affect the bonding with cement.
Clay lumps and friable particles	ASTM C 142	Clay lumps and friable particles will affect concrete strength and workability (CRD-C 142).
Lightweight particles	ASTM C 123	Lightweight particles will affect the density of concrete (CRD-C 122).
Particle shape	ASTM D 4791 CRD-C 120 ASTM D 3398	Particle shape will affect the density and workability of concrete (CRD-C 129).
Soundness of aggregate in concrete	CRD-C 114 (ASTM C 666)	Results are directly related to the F/T resistance of concrete.
Frost resistance	ASTM C 682	This test may be valuable in evaluating frost resistance of coarse aggregate in concrete (CRD-C 115).
Abrasion loss	ASTM C 131 ASTM C 535	These tests may indicate the degree of resistance to degrading of coarse aggregates during handling and mixing (CRD-C 117 and 145, respectively).
Specific heat	CRD-C 124	Needed for thermal analysis.
Linear thermal expansion	CRD-C 125 CRD-C 126	Needed for thermal analysis. Aggregates with very high or low thermal coefficient may require further investigation.
Alkali-silica reactivity	ASTM C 289 ASTM C 227	Perform these tests if there is an indication of potential alkali-silica reactivity (CRD-C 128 and 123, respectively). (See Appendix D for details.)
Alkali-carbonate reactivity	ASTM C 586	Perform this test if there is an indication of potential alkali-carbonate reactivity (CRD-C 146). (See Appendix E for details.)
Concrete making properties	ASTM C 39 and others	Perform these tests as needed to determine the suitability of aggregates for high strength concrete (CRD-C 14).

\*Test methods cited are from the American Society for Testing and Materials *Annual Book of ASTM Standards* (ASTM Annual) and from Department of the Army, Corps of Engineers, *Handbook of Concrete and Cement* (USAEWES 1949).



(f) Soft constituents, clay lumps, and lightweight particles (ASTM C 123 (CRD-C 122); ASTM C 851 (CRD-C 130); CRD-C 141; ASTM C 142 (CRD-C 142)). Results of tests for soft particles, clay lumps, and lightweight pieces are largely used as information that may have a bearing on or assist in rationalizing results of other tests such as the accelerated weathering test or the strength properties of the concrete. The tests may sometimes be useful in determining whether or not processing of the material to remove the undesirable constituents is feasible when they occur in proportions which make the material unfit for use without removal.

(g) Particle shape (ASTM D 4791; CRD-C 120; ASTM D 3398 (CRD-C 129)). The test for flat and elongated particles provides information on particle shape of aggregates. Excessive amounts of flat or elongated particles, or both, in aggregates will severely affect the water demand and finishability. In mass concrete structures, the amount of flat or elongated particles, or both, at a 3:1 length-to-width (L/W) or width-to-thickness (W/T) ratio is limited to 25 percent in any size group of coarse aggregate. Although there is no requirement in structural concrete, the effect of more than 25 percent flat or elongated particles should be examined during the design process. The results of the examination should be discussed in the appropriate design memorandum. The maximum L/W or W/T ratio, when testing in accordance with ASTM D 4791 is normally 3:1.

(h) Soundness of aggregate by freezing and thawing in concrete (CRD-C 114). This test is similar to ASTM C 666 (CRD-C 20), procedure A, except that a standard concrete mixture is used to evaluate the effect of aggregates on freezing-and-thawing resistance. This test is more severe than the aggregates will experience in service. Nevertheless, it provides an important measurement in relative aggregate quality in freezing-and-thawing resistance and is the best means now available for judging the relative effect of aggregates on frost resistance. In general, however, aggregates are rated in relative quality by this test as shown in Table 2-4. *This table also provides the recommended DFE value based upon the project location, and expected exposure. For the purpose of simplicity the weathering region (Fig. 1) in ASTM C 33 is used as an indicator of the potential freeze and thaw exposure for the area. The engineer may adjust this requirement if there is data available indicating that the situation is different from the one shown in ASTM C 33 Fig. 1.* Although the test is reasonably repeatable, it is not possible to prevent small differences in the size and distribution of air voids caused by different cements and air-entraining admixtures and possible other factors; thus, it is not possible to judge accurately the quality of protection of cement paste in each instance even though air content for all tests is kept within a small range. Therefore, it is not unusual to find that these differences will cause variations in test results of sufficient magnitude from two separate tests on essentially

identical aggregate samples to shift the quality rating from one level to another. The test also has limitations on the size of aggregates that can be tested. The maximum size of aggregate used in the tests is ~~190~~ 19.0 mm (3/4 in.), whereas aggregate up to 150 mm (6 in.) is frequently used in mass concrete. Therefore, the test is of limited value **when** the +19.0-mm (+3/4-in.) aggregate varies substantially in characteristics from that finer than 19.0 mm (3/4 in.). In spite of its limitations, the test provides an excellent means of evaluating the relative quality of most materials and results of the test should be given prime consideration in selecting aggregate quality requirements. Where the laboratory freezing-and-thawing test is considered inadequate as a basis for judging the quality of the aggregates, particularly for sizes larger than 19.0 mm (3/4 in.), concrete made with the larger sizes may be exposed at Treat Island, Maine, where the Corps of Engineers' severe-weathering exposure station is located to determine the durability of the specimens. The decision to expose specimens at Treat Island should be made early in the investigation so that they may be exposed for at least two winters. To determine durability, 2-ft cube specimens cast from air-entrained concrete containing the desired maximum size of aggregate should be used. In an average period of 2 years, specimens are subjected to at least 250 cycles of freezing and thawing. If no marked reduction in pulse velocity has occurred and no distress is visually evident in the period, the aggregates may be considered to be of good to excellent quality.

(i) Frost-resistance test (ASTM C 682 (CRD-C 115)). This dilation test provides another indication of aggregate quality in freezing-and-thawing resistance when used in concrete. It measures the dilation of a specimen under slow freezing-and-thawing cycles and is similar to ASTM C 671 (CRD-C 40) except a standard air-entrained concrete mixture is used. In air-entrained concrete in which the paste is adequately protected against frost action, the quality of the aggregate is the main factor that contributes to deterioration. Results of this test are very sensitive to the moisture condition of aggregate and concrete and should be compared carefully with the conditions in the field.

(j) Sulfate soundness (ASTM C 88 (CRD-C 137)). In the past, ASTM C 88, "Soundness of Aggregates by Use of Sodium Sulfate or Magnesium Sulfate," has been used quite often. This test is the only one which is performed on aggregate directly by soaking material in sulfate solution to simulate the effect of increase in volume of water changing to ice or freezing in the aggregate pores. ASTM C 88 is not recommended due to its poor correlation with the actual service performance of concrete.

(k) Abrasion loss (ASTM C 131 (CRD-C 117); ASTM C 535 (CRD-C 145)). If a material performs well in other tests, particularly resistance to freezing and thawing, high

Table 2-4  
Concrete Durability Factors for Assessing Aggregate Durability.

DFE Range*	Over 75	50-75	25-50	Less than 25
<i>Weathering Region per ASTM C33 Fig. I</i>	<i>Severe</i>	<i>Moderate</i>	<i>Negligible</i>	<i>No F/T cycle</i>
Quality Rating	Excellent	Good	Fair	Poor

\*DFE = Durability factor (based on relative dynamic modulus of elasticity).

abrasion loss may not be significant. It should be recognized, however, that a material having high abrasion loss will tend to degrade in handling and that excessive grinding may occur with such materials during mixing. These aspects should be investigated as a basis for evaluating the acceptability of a material. It should be noted that there is no relationship between abrasion loss from these tests and concrete abrasion or durability in service.

(1) Specific heat and thermal expansion (CRD-C 124, CRD-C 125, CRD-C 126). The results of these tests are properties of the aggregate and are needed when performing thermal analysis.

(m) Alkali-aggregate reactivity (ASTM C 227; ASTM C 289; ASTM C 586 (CRD-C 123, 128, and 146, respectively)). Criteria for recognizing potentially deleterious constituents in aggregate and for evaluating potential alkali-silica and alkali-carbonate reactivity are given in Appendixes D and E, respectively. If aggregates containing reactive constituents are to be used, the problem then becomes one of identifying the reactive constituents and determining the conditions under which the available aggregates may be used. Where the reactive constituents can be positively determined to occur in such small proportions as to be innocuous, an aggregate, if otherwise of suitable quality, may be used without special precautions. Where the reactive constituents occur in such proportions that they are potentially deleteriously reactive, it will be necessary to use low-alkali cement or an effective pozzolan, or both, with the aggregate. If the requirement of low-alkali cement would impose serious difficulties of cement procurement or excessive increase in cost, consideration should be given to the use of portland blast-furnace slag cement (a blend of portland cement and slag), Portland-pozzolan cement, cement with GGBF slag, or cement with a pozzolan, or both, that will prevent excessive reaction even when high alkali-cement is used. When consideration is given to the use of any of these materials in lieu of low-alkali cement, mortar-bar tests should be conducted to verify that the potentially deleterious expansion will be reduced to meet the criteria in Appendix D or E. If petrographic examination determines the presence of potentially reactive materials in excess of the limits given in Appendix D, mortar-bar tests, ASTM C 227 shall be performed. If the petrographic examination determines the presence of strained quartz in excess

of the limit given in Appendix D, the high- temperature mortar-bar test shall be performed.

(n) Concrete making properties (ASTM C 39 (CRD-C 14)). When it is desired to select aggregate for concrete with strengths of 6,000 psi or greater, some otherwise acceptable aggregates may not be suitable. Concrete-strength specimens, made from concrete using the aggregate being evaluated and of the required slump and air contents, should be tested at various cement factors, w/c, and including any required chemical admixtures. If the required strength cannot be obtained with a reasonable slump, air content, cement factor, and chemical admixture(s), the aggregate should not be considered as acceptable for the high strength concrete. Materials that are satisfactory in other respects usually have acceptable strength and bonding characteristics. A complete discussion of high-strength concrete may be found in ACI 363R.

(o) Service performance. The performance of aggregates in service in structures is considered the best general evidence of aggregate quality when dependable records are available and the exposure conditions are similar. Service records are usually of greater usefulness when commercial sources of aggregate are being investigated. Service performance, however, must be considered with caution. Poor condition of a structure is not necessarily evidence of poor quality aggregate. There are many factors which may contribute to the poor performance of the concrete in service. However, except where a slow acting reactive aggregate is involved, a structure in good condition is always an indication that the aggregates are of adequate quality for concrete exposed to similar conditions.

(7) Nominal maximum size aggregate. In general, it is economical to use the largest aggregate compatible with placing conditions. Table 2-5 provides guidance in making the selection. On projects not involving large quantities of

1 Feb 94

**Table 2-5**  
**Nominal Maximum Size of Aggregate Recommended for**  
**Various Types of Construction**

Features	Nominal Maximum Sizes
Section 7-1/2 in. or less in width or slabs 4 in. or less in thickness. Heavily reinforced floor and roof slabs. Parapets, corbels, and all sections where space is limited and surface appearance is important. High-strength concrete	19.0 mm (3/4 in.)
Section 7-1/2 in. wide and in which the clear distance between reinforcement bars is at least 2-1/4 in. and slabs at least 4 in. thick.	37.5 mm (1-1/2 in.)
Unreinforced sections over 12 in. wide and reinforced sections over 18 in. wide, in which the clear distance between reinforcement bars is over 4-1/2 in. Piers, walls, baffles, and stilling basin floor slabs in which satisfactory placement of 6-in. aggregate concrete cannot be accomplished even though reinforcement spacing would permit the use of large aggregate. Slabs 10 in. or greater in thickness.	75 mm (3 in.)
Massive sections of dams and retaining walls; ogee crests, piers, walls, and baffles in which clear distance between reinforcement bars is at least 9 in. and for which suitable provision is made for placing concrete containing the large sizes of aggregate without producing rock pockets or other undesirable results. Slabs 24 in. or greater in thickness.	150 mm (6 in.)

concrete, a careful study should be made of the economy of large aggregates. The use of large aggregates reduces the cement content, but it increases plant costs because provision must be made for the handling of more individual sizes. Nominal maximum size aggregate (NMSA), 150 mm (6 in.) or even 75 mm (3 in.), should not be specified if the volume of concrete is so small that savings in cement will not pay for increased plant expenses. When an economic study indicates the use of 75-mm (3-in.) or 150-mm (6-in.) NMSA concrete results in comparable costs and the additional cement required in the 75-mm (3-in.) NMSA concrete does not detrimentally affect the concrete, optional bidding schedules should be used. The additional cementitious quantities of 40 lb/cu yd of concrete is typical when 75-mm (3-in.) NMSA concrete is used in lieu of 150-mm (6-in.) NMSA concrete.

(8) Fine aggregate grading requirements. During the course of the aggregate investigations, the grading of the available fine aggregate from all sources should be determined and compared to the anticipated project

specifications. The project grading requirements will depend on the guide specification selected for the project. If the most readily available materials do not meet the applicable grading requirements and the processing required to bring the material into the specified grading limits results in increased costs, consideration should be given to substituting a state or local specification that is determined to cover the fine aggregate grading available at commercial sources in the project area. The substitution should be based on the determination that concrete meeting the project requirements can be produced using the locally available fine aggregate. If a large mass concrete structure is involved which will be built to the requirements of CW-03305, "Guide Specification for Mass Concrete," using an onsite fine aggregate source, the decision to waive the grading requirements will also be based on the results of the processibility study, which includes estimates of waste and laboratory data that show that concrete can be produced using the fine aggregate grading proposed which meets all the project requirements. The study should include an economic evaluation which shows, clearly, that the increased

cost of cement and finishing, when a nonstandard grading is used, will be more than offset by the savings in processing and waste reduction. Particular attention should be given to the increased workability gained by use of an optimum amount of material finer than the 300- $\mu\text{m}$  (No. 50) and 150  $\mu\text{m}$  (No. 100) sieves. Many studies have shown that it is cost effective to blend in a fine "admix" sand in this size range if the available sand is deficient in these sizes. The limits to be permitted on the proposed grading should also be stated. Manufactured fine aggregate has a tendency for the dust that is generated during the crushing and sizing process to cling to the larger particles and to clump or ball up when exposed to moisture. The amount of dust can be significant and can cause problems during construction. The dust may not come loose or break up during sieving per ASTM C 136 (dry grading), and it may be difficult to accurately monitor the grading. The dust can also cause the moisture content of stockpiled material to be higher and more variable than expected; this in turn can result in difficulties controlling the batch masses and slump of the concrete. Excessive dust can cause the water demand of concrete to increase with resultant loss of strength. Therefore, when manufactured sand is allowed in project specifications, the designer should invoke the optional requirements in CW 03305, "Guide Specification for Mass Concrete," that will limit the amount of material (dust) passing the 75- $\mu\text{m}$  (No. 200) sieve and that will require washing the material during grading testing (ASTM C 117 (CRD-C 105)). The option may also be invoked for natural fine aggregate at the designer's discretion.

(9) Required tests and test limits.

(a) General. For all civil works concrete construction projects except those for which the guide specification CW-03307, "Concrete for Minor Structures," is used, a list of required quality tests and test limits must be established and inserted in the specifications. Required tests and test limits must be site-specific for the project area, the general rule being that the best locally available aggregates are to be used. This list of tests and test limits may be specific for only one project or, according to the amount of diversity of the geology and the resulting rock types in an area, could be district- or division-wide lists. On some projects where, for instance, both river gravels and crushed stone are included in the list of sources, a set of tests and test limits would be required for the gravel and a slightly different set of tests and test limits would be required for the crushed stone.

(b) Acceptance criteria. Establishing test limits for aggregate quality for a project is very complex and should

be done with great care and deliberation. Limits established for a specific test for one rock type at one project would not necessarily assure durable concrete for a different rock type at the same project or for the same rock type at a different project. For example, a minimum density of 2.52 for coarse aggregate at a specific project may be adequate for some types of chert or river gravel but would not be adequate for crushed limestone. The selection of which tests to specify for indicating the quality of aggregate and the respective acceptance limits for each test should come after completion of all testing for each source or formation and should include due consideration of service records. The acceptance limits should be set recognizing that all test results have some scatter and that most ASTM (CRD) test methods include precision and bias statements. EM 1110-2-2302, "Construction with Large Stone," contains an excellent discussion on setting acceptance criteria and should be consulted for further guidance. The district materials engineer should work closely with the division office when establishing acceptance criteria for a project so that close coordination between adjacent districts and between adjacent divisions can be maintained for a given source or formation.

(10) Aggregate processing study. A processing study should be considered for any government-furnished source. The processing study should be conducted by a division laboratory having the capability of processing large (1- to 2-ton) samples. The sample should be processed to meet the grading and particle-shape requirements of the project by crushing and screening as necessary. The processing study will provide information on which to base estimates of waste and also will provide an indication of the potential for the development of flat and elongated particles to an extent which will influence the workability and cement requirements of the concrete. For large mass concrete jobs, a test quarry may be required. This is usually done as a separate construction contract to qualified private companies skilled in blasting (if a quarry operation) and skilled in processing rock or gravel deposits to meet concrete aggregate gradings. In this more elaborate type of investigation, the processing of the raw material would be accomplished onsite, instead of in the division laboratory. Information to be required would include optimum blasting patterns, quality of each rock stratum, amount of waste, particle shape, and the ability of the deposit to be processed into the required gradings.

(11) Location of government-furnished quarry or pit. The objective should be to define clearly one or more areas which will be described in the specifications and shown in the contract drawings. The purpose will be to provide the

1 Feb 94

bidders with information that will make it possible for them to estimate accurately the cost of producing the aggregate and subsequently to provide information to the contractor for use in planning his aggregate production operations. Explorations should be carefully logged and the information included in the contract drawings. Materials recovered during these and previous explorations should be preserved and made available for inspection by the bidders and by the Contractor for use in planning his work. Where zones or layers exist that are unsuitable, they should be specifically identified and the listing of the source should note the unsuitability of those zones or layers.

## 2-4. Water for Mixing and Curing

*a. General.* The most readily available water sources at the project site should be investigated during the PED phase for suitability for mixing and curing water. Also, water that will be in contact with the completed structure should be tested to determine if it contains a concentration of chemicals which may attack the hardened concrete. For additional information, see the Portland Cement Association's "Design and Control of Concrete Mixtures" (Kosmatka and Panarese 1988).

*b. Mixing water.* To determine if water from sources other than a municipal water supply is suitable for mixing, it should be investigated during the PED phase in accordance with CRD-C 400 (USAEWES 1949). If contamination by silt or a deleterious material exists, samples should be taken when contamination is the greatest.

*c. Curing water.* Water for curing must not contain harmful chemical concentrations and it must not contain organic materials such as tannic acid or iron compounds which will cause staining. If certain water sources around the project area have a potential for staining and others are nonstaining, the staining sources should be eliminated from use by the specifications and the acceptable sources noted so that unsightly staining may be prevented. However, the Contractor is responsible for providing surfaces free of stain after curing. This is a preferable approach to attempting to remove the staining with often unsatisfactory results. Curing water should be tested in accordance with CRD-C 400.

## 2-5. Chemical Admixtures

*a. General.* The chemical admixtures that may be used in concrete on Corps projects are air-entraining admixtures (ASTM C 260), accelerating admixtures, water-reducing admixtures, retarding admixtures, water-reducing and retarding admixtures, water-reducing and accelerating

admixtures, high-range water-reducing admixtures, and high-range water-reducing and retarding admixtures. All of the latter are discussed in ASTM C 494 (CRD-C 87). Chemical admixtures to produce flowing concrete are discussed in ASTM C 1017 (CRD-C 88). Other admixtures may be used when their use on the project results in improved quality or economy. When admixtures are considered during the PED phase to provide special concrete properties, trial batches with materials representative of those that will be used for the project should be proportioned and tested. The effects of the admixture on the concrete properties and the required dosage rate should be reported in the concrete materials DM. Admixtures proposed for use during construction should be checked with trial batches, using the actual project materials in the Division laboratory. However, if the source of the concrete is a ready-mix plant with a recent history of use of the admixture with project materials, trial batches need not be required. In some instances, adverse reactions may occur between admixtures or between admixtures and cement or water. Admixtures should not be mixed together prior to batching, but each should be batched separately. A detailed discussion of chemical admixtures for concrete is given in ACI 212.3R.

*b. Air-entraining admixtures.* Air-entraining admixtures (AEA's) are organic materials which entrain small air bubbles into concrete. These bubbles become a part of the cement paste that binds the aggregates together in the hardened concrete. Air entrainment improves the workability of concrete, reduces bleeding and segregation, and most importantly improves the frost resistance of concrete. Air entrainment is essential to ensure the durability of concrete that will become critically saturated with water and then exposed to freezing-and-thawing conditions. However, air entrainment only protects the paste fraction of the concrete. It does not protect concrete from deterioration caused by nonfrost-resistant aggregates.

(1) Policy. All civil works concrete should be air entrained with an appropriate AEA. Any exceptions to this practice must be submitted to CECW-EG for approval.

(2) Strength loss. Even if freezing-and-thawing conditions are not prevalent, concrete should be air entrained because of the benefits imparted in other ways. The presence of entrained air results in an improvement in the workability of concrete at the same water content. To maintain a given slump, a reduction in the water content of up to 15 percent can be made depending upon the air and cement contents. The reduction in the water content results in a lower w/c, which will offset some or all of the loss in strength due to the presence of the entrained air, depending on the cement content; calculations indicate that at about

300 lb of cement per cubic yard, an increase in air content will be balanced by a sufficient decrease in w/c at constant slump to maintain constant strength.

(3) Bleeding. Air-entrained concrete is less susceptible to bleeding. When successive lifts of concrete are to be placed, more effort will be required for horizontal lift joint cleanup if bleeding is excessive. A considerable reduction in bleeding by proper air entrainment is usually a major benefit. Air entrainment also imparts a buoyant action to the cement and aggregate particles which helps to prevent segregation. Even though it is an aid against segregation, it cannot prevent segregation of concretes having poorly graded aggregates, ones that are excessively lean or wet, or ones that are improperly transported or placed.

(4) Batching AEA. An AEA should be added to the mixing water prior to its introduction into other concrete materials. If other admixtures are also used, the AEA should be added to the concrete mixer separately and not intermixed with the other admixtures.

(5) Dosage. Many variables will determine the exact dosage of an AEA needed to achieve the proper air-void system in a concrete mixture. In general, larger amounts of AEA will produce higher air contents in a concrete mixture. However, there is no direct relationship between the dosage rate of a given AEA and the air content that is produced.

(6) Effects of water content on air content. Air content will usually increase or decrease as the water content of a mixture is increased or decreased. An increase in the water content in the concrete results in a more fluid mixture into which the air bubbles can be more easily incorporated by the mixing action. For example, a slump increase of about 3 in. can cause an increase in air content of about 1 percent with the same dosage of an AEA.

(7) Effects of fine aggregate grading on air content. Air is more easily entrained in concretes having higher percentages of fine aggregate. The fine aggregates provide interstices that can contain the air bubbles, especially the sizes from about 600  $\mu\text{m}$  (No. 30) to the 150  $\mu\text{m}$  (No. 100). Concretes made with fine aggregates deficient in particles of these sizes can require larger amounts of AEA's to achieve the desired air content, especially in lean concretes. Conversely, concretes made with an excess of finely divided materials can also require larger amounts of AEA's to achieve the desired air content. Very fine sand fractions (150  $\mu\text{m}$  (No. 100) and smaller), fly ash, and high cement contents have caused a reduction in air contents. Fly ashes which have high loss on ignition cause an especially large reduction in the air content. Concrete made with a Type III

cement can require up to 50 percent more AEA's than concrete made with a Type I cement.

(8) Effects of temperature on air content. The temperature of the concrete has a direct effect upon the air content of the concrete at given AEA dosage. A lower temperature results in a higher air content, and vice versa. Therefore, if the concrete temperature changes significantly during production of a particular concrete mixture, it is likely that the amount of AEA must be adjusted accordingly to maintain the desired air content.

(9) Effect of other admixtures on air content. Less AEA is generally required to entrain air in concrete when water-reducing or retarding admixtures are also used. The required amount of AEA may be as much as 50 percent less, especially when lignosulfonate-based chemical admixtures are used because these materials also have a moderate air-entraining capacity.

(10) Effect of mixing action on air content. Effective mixing action is necessary to produce air-entrained concrete. The amount of entrained air will vary with the type and physical condition of the mixer, the mixing speed, and the amount of concrete being mixed. It is more difficult to entrain air in concrete using a severely worn mixer or one that has an excessive amount of hardened concrete buildup on the blades or in the drum. Air contents can also decrease if the mixer is loaded above its rated capacity. Studies have shown that air contents generally increase with mixing up to about 15 min. Thereafter, additional mixing leads to a decrease in air content, especially for low-slump concretes. Any transporting technique that will continue to agitate the concrete, such as pumping or conveying, usually decreases the air content.

*c. Accelerating admixture.* Accelerating admixtures are classified by ASTM C 494 as Type C, accelerating, or Type E, water-reducing and accelerating. Accelerating admixtures accelerate the setting time or early strength development of concrete or both. Initial and final setting times must be accelerated by a minimum of 1 hr, and 3-day compressive strengths must be increased by a minimum of 25 percent in order for an accelerating admixture to comply with the requirements of ASTM C 494 (CRD-C 87).

(1) Uses. CW-03301 and CW-03305 provide for the use of nonchloride accelerating admixtures subject to the approval of the Contracting officer. The use of a nonchloride accelerating admixture may be approved when concrete is being placed in cold weather to partially offset the retarding effect of the lower temperatures. Its use permits earlier finishing of slabs and reduces form removal

delays. The use of an accelerating admixture does not permit a reduction of specified curing and protection periods.

(2) Nonchloride admixtures. Several nonchloride organic and inorganic compounds, such as calcium formate, calcium nitrite, and triethanolamine, are available as accelerators. However, experience and published research on these admixtures are limited. The available data suggest that none of the nonchloride accelerating admixtures are as powerful an accelerator as calcium chloride at equal dosages. However, adequate acceleration can usually be attained with a nonchloride accelerating admixture if the proper dosage is used. Nonchloride accelerators usually come in liquid form and should be added at the mixer with a portion of the mixing water at a dosage rate recommended by the manufacturer. They should be added to the concrete separately and not mixed with other admixtures. In some instances, adverse reactions occur between admixtures which can decrease their effectiveness.

(3) Effect on fresh concrete properties. Type C accelerating admixtures have no significant effect on the initial workability or air content of a concrete mixture; however, the setting time, heat evolution, and strength development are affected. Concretes containing an accelerating admixture can have a more rapid slump loss, especially concretes having a high cement content. The bleeding of a concrete mixture is generally reduced when an accelerating admixture is used.

(4) Effect on hardened concrete properties. Properties of hardened concretes containing an accelerating admixture are generally increased at early ages but may be decreased at later ages. Compressive and flexural strengths will be higher at early ages but can be lower than those of plain concrete at later ages. Both creep and drying shrinkage may increase. Concretes containing accelerators may be less resistant to aggressive environments, especially at later ages. The passive layer of protection at the concrete-steel interface does not appear to be attacked by nonchloride accelerators. Proper curing procedures are essential when concrete contains an accelerating admixture.

(5) Other methods of accelerating strength development. Frequently, the acceleration of setting time and early strength development can be obtained by other means, such as (a) using a Type III portland cement, (b) using additional cement, (c) lowering the pozzolan content, (d) warming water and aggregates, (e) improving curing and protection, or (f) some combination of these. In some cases, the use of an accelerator is the most convenient and economical method of achieving the desired results;

however, convenience and economics should not take precedence over durability considerations.

*d. Retarding admixtures.* Retarding admixtures are materials which cause a delay in initial and final setting times. However, retarding admixtures do not reduce the rate of slump loss. Retarding admixtures are classified by ASTM C 494 (CRD-C 87) as Type B, retarding, or Type D, water-reducing and retarding. They must retard the initial setting time by a minimum of 1 hr and the final setting time by a minimum of 3-1/2 hr. Setting times of concrete made with a portland cement-pozzolan blend will typically be retarded more than when portland cement alone is used. The pozzolan often has a retarding action.

(1) General uses. By using the proper dosage of a retarding admixture, the setting time of a mixture can be extended so as to avoid cold joints and allow for proper finishing. A change in temperature could require an adjustment in the dosage of retarder to maintain the desired setting time. Retarding admixtures can be beneficial in hot weather, when long hauling distances are unavoidable, or anytime extended working times are desirable. The time between screeding and troweling operations of concrete slabs is extended when retarding admixtures are used. This can be particularly beneficial in hot weather; however, unless proper precautions are taken, such as the use of sunscreens and wind screens, the surface may dry prematurely and create a crust on the surface. Under these conditions, careful attention to curing and protection is required to obtain a uniform hardening in the entire concrete slab. Retarding admixtures based on hydroxylated carboxylic acids and their salts are beneficial in concrete used in flatwork construction during hot weather since they induce bleeding and, therefore, aid in the prevention of a premature drying of the top surface.

(2) Dosage. The dosage of admixture recommended by the manufacturer should be used unless experience or results of trial batches indicate otherwise. High temperatures may require higher dosages of retarding admixtures; however, overdosage can cause excessive retardation requiring longer curing times and delays in form removal. The degree of excessive retardation could be from a few hours to a few days. However, an accidental overdosage of a retarding admixture does not adversely affect the later age properties of a concrete if the concrete is cured properly and the forms are not removed until sufficient strength has been attained. Research has shown that a higher dosage of retarding admixtures is needed when used with portland cements that have high  $C_3A$  and  $C_3S$  contents, as well as a high alkali content. Therefore, to achieve the same effects, a larger dosage of retarding admixture will probably be required if

a Type I portland cement is used than will be required if a Type II, low-alkali portland cement is used.

(3) *Batching.* Retarding admixtures should be added to the mixing water prior to its introduction into other concrete materials. If other admixtures are also used, the retarding admixture should be added to the concrete mixture separately and not mixed with the other admixtures. In some instances, adverse reactions occur between admixtures which can decrease their effectiveness.

(4) *Effect on strength.* When retarding admixtures are used in concrete, early-age compressive and flexural strength may be reduced. If a low dosage of admixture is used, the lower strengths may be evident for as few as 1 or 2 days. Greater degrees of retardation may cause the strengths to be lower for 3 to 7 days. However, in most cases there will be no retardation of strength development by 28-days age. Lower strengths may exist for a longer period of time if the concrete is made with a portland cement-pozzolan blend. At later ages, the strength of concrete made with a retarding admixture will usually be higher than that of concrete containing no retarding admixture.

*e. Water-reducing admixtures.* Water-reducing admixtures (WRA's) are organic materials which reduce the amount of mixing water required to impart a given workability to concrete. By definition, WRA's are required to provide a water reduction of at least 5 percent and are classified by ASTM C 494 (CRD-C 87) as Type A, water-reducing; Type D, water-reducing and retarding; or Type E, water-reducing and accelerating. They can be used to increase strength, increase workability, or reduce the cement content of a concrete mixture.

(1) *Use in mass concrete.* A WRA generally should not be allowed in lean mass concrete mixtures since neither high strength nor high slump are usually required from these mixtures. A reduction in the cement content permitted by the use of a WRA could result in the mixture having inadequate workability. This is especially true for mass concrete mixtures containing 37.5-mm (1-1/2-in.) or larger nominal maximum size aggregate.

(2) *Dosage.* The usual dosage rate for a WRA is between about 2 and 8 fl oz/100 lb of cementitious material. The appropriate amount will be determined by the brand of WRA being used as well as the combination of other concrete materials. Some WRA's meet ASTM C 494 (CRD-C 87) requirements for both Type A and Type D, depending upon the dosage rate used. These WRA's will usually react as a Type A at the lower limit of the

recommended dosage range and as a Type D at the upper limit of the recommended dosage range.

(3) *Use in hot or cool weather.* A Type D WRA can be beneficial when working in hot weather, when long hauling times are involved, or anytime extended working times are desirable. However, the retarding effect increases the concrete setting time only. It does not slow the rate of slump loss. In fact, concretes containing either Type A, Type D, or Type E WRA generally lose slump at a faster rate than when a WRA is not used. A Type E WRA may be beneficial when working in cool temperatures or when higher earlier strengths are desired.

(4) *Air entrainment.* Most lignosulfonate WRA's will entrain air. However, the amount of entrained air will usually not be sufficient to provide adequate frost resistance. An AEA will be required in addition to the WRA, but the amount of AEA necessary may be as much as 50 percent less. WRA's based on other compounds generally do not entrain air but do enhance the air-entraining capability of AEA's.

(5) *Bleeding.* WRA's affect the rate and capacity of fresh concrete to bleed. Lignosulfonate WRA's reduce the bleeding rate and capacity while WRA's based on hydroxylated carboxylic acids and their salts increase the bleeding rate and capacity of a concrete mixture. A lignosulfonate WRA should be used with caution in concrete placed in slabs during hot weather. With little bleed water migrating to the surface, rapid surface drying could occur, leading to a crust on the concrete surface while the concrete underneath remains plastic. The potential for plastic shrinkage cracking is also greater. It is beneficial to induce bleeding under these ambient conditions. WRA's based on hydroxylated carboxylic acids and their salts will accomplish this objective.

*f. High-range water-reducing admixtures ("superplasticizers").* High-range water-reducing admixtures (HRWRA's) are chemically different from normal WRA's and are capable of reducing water contents by as much as 30 percent without detrimentally affecting air content, bleeding, segregation, setting time, and hardened properties. By definition, HRWRA's are required to provide a water reduction of at least 12 percent and are classified by ASTM C 494 as Type F, high-range water-reducing, or Type G, high-range water-reducing and retarding. HRWRA's can be used to produce concrete having high workability for easy placement, high strength with normal workability, or combinations of the two. HRWRA's can also be used to produce flowing concrete as described by ASTM C 1017



1 Feb 94

(CRD-C 88). Additional information on flowing concrete may be found in paragraph 10-9.

(1) Effect on workability. Significantly higher compressive strengths are possible with the use of an HRWRA. Concrete can be produced having a lower w/c without the loss of workability that could occur with the use of WRA's. The increased workability made possible with an HRWRA permits easier placement of concrete in congested reinforcement and in areas where access is limited. HRWRA's are beneficial in concrete which is pumped or placed by tremie because they improve workability without a loss in cohesiveness. The dispersing action of HRWRA is effective on both portland cements and pozzolans. The ability of an HRWRA to increase the slump of concrete depends upon the chemical nature of the HRWRA, the dosage used, time of addition, initial slump, composition and amount of cement, and concrete temperature. Recommended dosages of HRWRA's are usually greater than those of WRA's. There are some limitations of HRWRA's that should be recognized. Under some conditions, concretes containing HRWRA's may exhibit a rapid slump loss as soon as 30 min after completion of mixing. Therefore, HRWRA's are often added to truck mixers at the job site to minimize placing and consolidation problems associated with concrete which stiffens rapidly.

(2) Effect on segregation and bleeding. When HRWRA's are used as water reducers, bleeding of the concrete is usually reduced. Segregation of the aggregates will not be a problem. When HRWRA's are used to produce flowing concrete, both bleeding and segregation can occur if precautions are not taken. Increasing the volume of sand in the mixture by 3 to 5 percent may be necessary. The dosage of HRWRA should be limited to the minimum amount necessary to produce the desired slump. An overdose can cause excessive bleeding and segregation. However, bleeding and segregation of a high-slump concrete is not as pronounced when the high slump is achieved through use of an HRWRA as would be the case if the high slump were achieved through the addition of extra water. Retempering once with an HRWRA is generally an acceptable practice.

(3) Effect on air entrainment. Some HRWRA's enhance the air-entraining capability of AEA's. However, HRWRA's can also facilitate the escape of air. Repeated dosing with an HRWRA can accentuate this effect. In addition to the rapid slump loss, a significant loss of air can occur.

(4) Effect on setting time. A Type F HRWRA has little effect upon setting times of concrete, while a Type G HRWRA retards the setting time. The usual dosage range for HRWRA is between about 10 and 30 fl oz/100 lb of cementitious materials. The appropriate amount will be determined by the type of HRWRA being used as well as the combination of other concrete materials and admixtures. Some HRWRA's meet ASTM C 494 requirements for both Type F and Type G, depending on the dosage rate used. These HRWRA's will usually react as a Type F at the lower end of the recommended dosage range and as a Type G at the upper end of the recommended dosage range. If one of these HRWRA's is being used at a low dosage, and it is desired to increase the dosage for additional water reduction, caution should be exercised. The higher dosage could cause undesirable retardation of concrete setting time and strength.

(5) Compatibility with other admixtures. HRWRA's are generally compatible with most other concrete admixtures. However, each admixture combination should be evaluated prior to being used. In particular, attention should be given to the air content and air-void system parameters. Appropriate durability tests should be performed depending on the environment to which the concrete will be subjected. When concrete containing an HRWRA is properly air entrained, it will be as durable as that without an HRWRA.

*g. Antiwashout admixtures.* In recent years a group of chemical admixtures known as antiwashout admixtures (AWA's) has been introduced into the concrete products market. ASTM standard specifications have not yet been developed for these admixtures. They are used to increase the cohesiveness of a concrete to prevent excessive washing out of cementitious materials when the concrete is placed underwater. A workability transformation occurs after several minutes of mixing, thereby causing the concrete to become very sticky. Present guide specifications do not include AWA's. The use of AWA's should be discussed in the appropriate DM.

(1) General. AWA's can be made from various organic and inorganic materials. The two materials most commonly marketed as AWA's are cellulose and gum. They act primarily by increasing the viscosity and the water retention of the cement paste. Both materials are very effective in increasing the washout resistance of a concrete mixture. The washout resistance depends upon the type and dosage of AWA, w/c, cement content, and other admixtures used. In general, the washout resistance increases with an increase of AWA, a decrease in w/c, and an increase in

cement content. The loss of cementitious materials due to washing is typically reduced by as much as 50 percent when concrete contains an AWA.

(2) Batching. AWA's based on cellulose are normally packaged in a powder form. They are usually added to the concrete mixer with the cement. AWA's based on gum may be packaged either as a powder or liquid. The powder should be put into solution with a portion of the mixing water prior to introduction into the concrete mixture. The liquid can be added with the mixing water.

(3) Air entrainment. AWA's based on cellulose tend to entrain air. In combination with some WRA's or HRWRA's, AWA's will entrain an excessive amount of air. When this occurs, an air-detraining admixture must be incorporated into the concrete mixture to reduce the air contents to acceptable levels. AWA's based on gum usually do not entrain air.

(4) Bleeding. Since AWA's increase the water retention of cement paste, virtually no bleeding occurs in concretes containing these admixtures. However, this would normally be of little concern in concrete placed underwater.

(5) Retardation. AWA's based on cellulose tend to retard the setting time of concrete. Larger dosages of these AWA's can retard concrete setting times significantly, in some cases up to 24 hr. If the delayed setting time poses problems with other construction operations, an accelerator can be used to partially offset the retardation. AWA's based on gum usually do not retard setting times as much as those based on cellulose.

(6) Compatibility. AWA's have little effect on compressive strengths of concrete. The amount of mixing water necessary for concrete made with an AWA is greater than would be necessary for concrete without an AWA. In many cases the amount of mixing water can be reduced with a WRA or an HRWRA. In fact, when concretes have w/c less than 0.50, the use of a WRA will probably be necessary. When the w/c is less than 0.40, the use of an HRWRA will be necessary to achieve the flowability necessary for an underwater placement. Cellulose-based AWA's and naphthlene sulfonate-based HRWRA's are incompatible, and combinations of these should be avoided. Cellulose-based AWA's are generally compatible with other types of HRWRA's and most WRA's. Gum-based AWA's are generally compatible with most WRA's and HRWRA's.

(7) Dosage. The proper dosage of AWA's, WRA's, and HRWRA's, as well as the compatibility of these admixtures, must be determined in trial batches prior to the

beginning of any concrete placement. The amount of an AWA necessary to achieve the desired washout resistance can vary considerably depending upon the concrete materials being used and their proportions. An excessive amount of AWA can render the concrete unworkable, while too little AWA will not provide adequate washout resistance. Follow the manufacturers recommendations for dosages and adjust as necessary in preliminary trial batches. Extreme caution should be exercised if it becomes necessary to adjust the dosage of either the AWA, WRA, or HRWRA after the actual placement begins. A small change in the dosage can result in a dramatic change in the workability and cohesiveness of the concrete. When the use of an AWA is specified, the services of a qualified manufacturer's technical representative should be required. The technical representative should be available during mixture proportioning studies and be onsite during concrete placement. The concrete mixture containing the AWA should be proportioned in the division laboratory if the mixture is government furnished or in an approved commercial laboratory if proportioning is a Contractor responsibility.

(8) Pumping. The cohesiveness imparted by an AWA actually improves the pumpability of concrete for distances up to approximately 150 ft. If the pumping distance exceeds 250 ft, pumping pressures will likely increase significantly. If the pumping pressures become excessive, the concrete mixture proportions must be adjusted by adding water or reducing the amount of the AWA, or the pump must be relocated to reduce the pumping distance. Adjusting the mixture proportions in this manner may reduce the concrete cohesiveness and cause it to be more susceptible to washout; therefore, relocating the pump, if possible is the preferable solution.

*h. Extended set-control admixtures.*

(1) General. These admixtures are relatively new to the commercial market and were developed to give the ready-mixed concrete producer maximum flexibility in controlling the rate of hydration of fresh concrete. They are typically marketed as a two-component system consisting of a very strong retarding admixture, sometimes referred to by the manufacturer as a stabilizer, and an accelerating admixture, sometimes labeled as an activator by the manufacturer. These admixtures allow the concrete producer to take advantage of severely retarded fresh concrete in several ways, including:

(a) Treating unhardened concrete which is returned to the plant with the stabilizer so that it can be kept in the unhardened state, or stabilized, in the truck mixer or holding

hopper for several hours. When the concrete is needed, cement hydration is normally reactivated by combining freshly mixed concrete with it before sending it to the job site. Returned unhardened concrete may also be stabilized overnight or longer. In these cases, hydration of the cement in the stabilized concrete is typically reactivated by adding the activator and then combining the concrete with freshly mixed concrete before delivering it to the job site.

(b) Treating the freshly mixed concrete at the plant with the stabilizer so that hydration is retarded to the extent necessary for very long hauls. Typically, the duration of retardation is at least 1 or more hours, and use of the activator may or may not be necessary at the job site, depending on the dosage of stabilizer used.

(c) Stabilizing plastic concrete in a truck mixer which has experienced a mechanical breakdown or an unforeseen delay. In the event of a truck breakdown, the mixer drum must still be able to turn.

(d) Treating wash water from mixers with the stabilizing admixture to reduce the need for conventional wash water disposal methods and thereby mitigating the environmental concerns. Water consumption is also reduced. The stabilized wash water is then reused as mixing water in the concrete batched the next day or after the weekend.

(2) Stabilizer. The stabilizing admixture slows the rate of hydrate formation by tying up, or complexing, calcium ions on the surface of cement particles. It not only forms a protective barrier around the cement particles but also acts as a dispersant preventing hydrates from flocculating and setting. This protective barrier prevents initial set from occurring.

(3) Activator. The activating admixtures typically supplied with the extended-set admixture systems are nonchloride accelerating admixtures conforming to ASTM C 494, Type C (CRD-C 87).

(4) Effect on hardened properties. Few published data exist on the effects of extended set admixtures on the hardened properties of concrete. However, research indicates the use of a stabilizing admixture may cause finer and denser hydrates to form, which, in turn, appears to benefit physical properties of paste.

(5) Dosage. Extended-set control admixtures are usually delivered in liquid form. Because they are still relatively new to the concrete industry and because there are presently no standard specifications for them, their use

should be permitted only after data are supplied by the concrete supplier that the fresh and hardened properties of the concrete anticipated for use will not be detrimentally affected. Manufacturer's technical representatives should work closely with the concrete producer to assure correct dosage rates are established for the particular concretes and field applications.

*i. Antifreeze admixtures.* A new group of chemical admixtures recently introduced into the concrete products market is known as antifreeze or freezing-protection admixtures. ASTM standard specifications have not yet been developed for these admixtures. These materials, which have been in use in the former USSR since the 1950's and more recently in Western Europe, are designed to depress the freezing point of mixing water and thereby allow concrete to gain strength in an environment below freezing without suffering the deleterious effects of ice formation. Concrete made with antifreeze admixtures can be cured at temperatures below freezing without harming its performance compared to that of concrete without the antifreeze admixture and cured at normal temperatures.

(1) Composition. Antifreeze admixtures are similar in composition to accelerating admixtures, but differences do exist. ACI 212.3R states that accelerating admixtures should not be used as antifreeze admixtures. However, some compounds used as the basis for nonchloride accelerating admixtures, such as sodium nitrite, calcium nitrite, and potassium carbonate, have been successfully used as antifreeze admixtures.

(2) Batching. Antifreeze admixtures are usually delivered in liquid form and should be added at the mixer with a portion of the mixing water at a dosage rate recommended by the manufacturer. They should be added to the concrete separately and not mixed with other admixtures, since adverse reactions may occur between admixtures which can decrease their effectiveness.

(3) Effect on strength. When antifreeze admixtures are used, early-age compressive strengths are usually significantly lower than when the admixture is not used and the concrete is cured at normal temperatures. The strength gain of concrete which contains an antifreeze admixture and is cured at temperatures below freezing proceeds at a slower rate than concrete which does not contain the admixture and is cured at temperatures above freezing. However, the strengths of two such concretes may be comparable at later ages.

(4) Effect on resistance to freezing and thawing. There is little published documentation describing the frost

resistance of concrete made with antifreeze admixtures; however, there is evidence that entrained air bubbles are less stable when antifreeze admixtures are used. Therefore, these admixtures should not be used unless acceptable frost resistance has been verified according to provisions of ASTM C 494 (CRD-C 87).

(5) Use with reactive aggregates. When sodium nitrite and potassium carbonate go into solution, if the nitrite or carbonate ions precipitate out, the sodium or potassium ions will associate with hydroxide ions to raise the pH of the pore fluid. Therefore, antifreeze admixtures containing these materials should not be used with reactive siliceous aggregates. Concrete made with these materials has also weakened after repeated exposure to cycles of wetting and drying. Therefore, antifreeze admixtures containing sodium

nitrite or potassium carbonate should not be used in a marine environment.

(6) Corrosion of steel. Antifreeze admixtures made from nonchloride compounds have shown no tendency to cause corrosion of embedded reinforcing steel. Sodium nitrite and calcium nitrite reduce corrosion when used in proper amounts.

(7) Cost benefits. The use of an antifreeze admixture in concrete can be cost effective. The cost of concreting in very cold weather may be as much as 50 to 100 percent higher than that under normal conditions due to increased equipment and labor costs. The cost of antifreeze admixtures may be competitive with the higher costs associated with concreting during subfreezing temperatures.

## Chapter 3 Construction Requirements and Special Studies

### 3-1. Construction Requirements

*a. General.* As the concrete materials design of a project nears its conclusion, adequate data should be available related to likely sources of aggregate, water, and locations of haul roads and access roads to determine if an onsite or offsite plant is required, and if an onsite plant is required, the site location. In addition, requirements for batching plants, mixers, conveying, and placing equipment must be established and included in the appropriate DM to guide in the preparation of the plans and specifications.

*b. Batch-plant location.* The batch plant may be located onsite or offsite. For a very large dam being built in a remote location, an onsite plant would be a certainty, and for a culvert headwall in a metropolitan area, the concrete would certainly be supplied by a ready-mix firm acting as a supplier to the Contractor. Between these two extremes, there are numerous possibilities that will depend on the scope and location of the work, the nominal maximum size aggregate required, the desired placing rate, the anticipated workload of the local ready-mix producers during the period of construction of the Corps projects, and the availability or nonavailability of a government-controlled aggregate source. Specifically, the concrete batching plant is normally required to be located onsite when the closest source of ready-mixed concrete is remote from the project, the nominal maximum size aggregate required makes ready-mixed concrete impractical and the required placing capacity cannot be maintained by an offsite plant. An offsite plant should be considered when the maximum size aggregate is 37.5 mm (1-1/2 in.) or less, commercial concrete plants exist in the project area, the plants are close enough that the interval between concrete batching and final placement will be 1-1/2 hr or less, and the required placement rate can be maintained. Obviously, on many projects, the decision between an onsite or offsite plant is not clear cut. The type of batching and mixing equipment at each commercial plant should be surveyed and summarized in the concrete materials DM. If more than one source exists as potential supplier, all such sources should be investigated and, if acceptable, be listed in the concrete materials DM. If the potential exists for either an onsite plant or the use of offsite commercial source, it should be possible for the bidders to have the option of setting up and operating an onsite plant or procuring concrete offsite.

*c. Batch-plant type.* Available options in batching equipment include automatic, semiautomatic, partially

automatic, manual, and volumetric batching (ACI 304R, CRD-C 514, and ASTM 685 (CRD-C 98)). The choice of the batch-plant control system is dependent on the type of concrete, the volume of concrete required, the number of coarse aggregate sizes, and the importance of the structure. If mass concrete is being placed, an automatic plant will be specified when four sizes of coarse aggregate are used, where three sizes of coarse aggregate are used and 75,000 yd<sup>3</sup> or more of concrete is involved, or when two sizes of coarse aggregate are used and more than 100,000 yd<sup>3</sup> of concrete is involved. A semiautomatic batch plant may be specified for mass concrete if not more than three sizes of coarse aggregate are used and less than 100,000 yd<sup>3</sup> of concrete is involved. If cast-in-place structural concrete is the type of concrete that will be predominant on the project, the batching equipment specified may be automatic, semiautomatic, or partially automatic. For major projects involving important structures or where critical smaller structures are involved, the optional interlocks and recorders should be required. If the concrete to be placed on a project is only for minor structures, any of the above plants are suitable, plus batch plants having manual controls or incorporating volumetric batching. The selection of batching and mixing plant requirements must take into account both economy and technical requirements for adequate control of quality. Economic considerations include initial plant cost, economy of operation (production rates), and economy in concrete materials, particularly cement. It may be noted that either an automatic or semiautomatic plant may be specified where three sizes of coarse aggregate are used, depending on volume of concrete involved and the nature of the work. The choice in these cases is largely dependent on economy. Batch plant types, including volumetric batching, are discussed in ACI 304R.

*d. Mixer type.* Stationary tilting-drum mixers should be used for mixing concrete containing 150-mm (6-in.) NMSA. For mixing concrete containing 75-mm (3-in.) NMSA, stationary tilting-drum, pugmill, spiral blade, or vertical shaft mixers may be used. However, for concrete containing 75- or 150-mm (3- or 6-in.) NMSA, the Contractor may choose any stationary mixer if it meets the required capacity and complies with the uniformity requirements when tested in accordance with CRD-C 55. Concrete containing 37.5-mm (1-1/2-in.) and smaller NMSA may be mixed in stationary mixers or truck mixers. For minor structures, any of these types of mixers may be used as well as a continuous mixer with volumetric batcher. When volumetric batching and continuous mixing are used for minor structures, the equipment must meet the requirements of ASTM C 685 (CRD-C 98).

e. *Batching and mixing-plant capacity.* Careful consideration must be given to the determination of the required concrete production capabilities. This determination is important for both large concrete locks and dams using an onsite batching and mixing plant and for smaller structures that may use an offsite plant and trucks for mixing or hauling or both.

(1) *Monolith size.* A likely construction progress schedule should be developed during the PED phase of a concrete structure. The fixed constraints such as committed power-on line or lock operation dates and seasonal constraints should be incorporated into the schedule. Recently completed similar projects in the area should be reviewed to determine the maximum placement rates achieved. The likely placement methods such as crane and bucket, pump, or conveyor have to be determined and the structures analyzed so that the largest continuous placements are identified. The size of the placements are defined by the placement of construction joints. Construction joints should be shown on the drawings and should be placed by the structural designer to coincide with structural features and reinforcing locations. The thermal study will also provide input for maximum size of monolith and maximum lift heights. Construction joints should be located to provide for as many placements as possible to be approximately the same volume. If one placement is several times the volume of all other placements on a project, this will require a much larger batching and mixing plant capacity than would be necessary if smaller placements were used. For many smaller structures, a plant size that will prevent cold joints will be too small to meet the tentative construction progress schedule. Regardless of the daily requirements, the plant capacity has to be such that fresh concrete does not remain in the form prior to placement of contiguous concrete long enough to develop a cold joint. The time that concrete may remain in the form before a cold joint develops is highly variable. For example, in warm dry climates the time may have to be reduced 50 percent or more. The time may be extended by the use of a retarder (ASTM C 494 (CRD-C 87)). As a rule of thumb for initial computation, 2 hr may be considered the maximum time that cooled concrete is uncovered before a cold joint will form between the concrete in place and the new concrete. For uncooled mass and structural concrete, 1 hr is the maximum time that it should be uncovered. A cold joint is defined as concrete that is beginning to set and in which a running vibrator will not sink under its own weight and a hole is left in the concrete when the vibrator is slowly withdrawn. When a cold joint is formed, concrete placement should be stopped and the cold joint should then be treated as another construction joint. The selection of the plant size should provide adequate safety factors to cover the variables.

(2) *Traditional placing method.* For massive structures such as locks and dams, the traditional placement method has been buckets that are moved on trucks and placed with cranes. There should be a limit of 4 yd<sup>3</sup> as the maximum amount of concrete placed in one pile prior to the consolidation. A typical lift height of 5 or 7-1/2 ft with an approximate horizontal layer thickness of about 1-1/2 ft would require five successive horizontal layers in stepped progression in 7-1/2-ft lifts and three successive horizontal layers in stepped progression in 5-ft lifts.

(3) *Equation for minimum placing capacity.* The minimum plant capacity may be estimated by using the following equation or by calculating graphically as illustrated in paragraph 3-1e(4):

$$Q = (n+1) \frac{WB}{bh} \tag{3-1}$$

where

- Q = Plant capacity, yd<sup>3</sup>/hr
- W = Width of placement (monolith), ft
- B = Bucket size, yd<sup>3</sup>
- b = Width of block per bucket, ft. A block is assumed to be a square with a height equal to approximately 1-1/2 ft. For 4-yd<sup>3</sup> bucket, b = 8-1/2 ft
- h = Maximum time before cold joint forms, hr. For estimating purposes, use h = 2 for cooled concrete and h = 1 for uncooled concrete.
- n = Number of layers per lift, normally three layers for 5-ft lift and five layers for 7-1/2-ft lift.

(4) *Graphic calculation of minimum placing capacity.* Figures 3-1 and 3-2 illustrate graphically the placing sequences for 7-1/2- and 5-ft lifts, respectively, with a 4-yd<sup>3</sup> bucket. As shown in Figure 3-1, the required plant output will reach the maximum after 60 buckets of concrete have been placed. Each bucket placed after 60 buckets will be exposed, while 36 additional buckets are being placed. Therefore, for cooled mass concrete while each placement may be exposed for 2 hr before cold joint forms, the required minimum plant capacity will be 36 × 4 = 144 yd<sup>3</sup> in a 2-hr period or 72 yd<sup>3</sup> per hour. In Figure 3-2, where a 5-ft lift is used, the maximum plant output will be reached at the sixteenth bucket, and 20 buckets will be placed before it will be covered. Therefore, for cooled concrete, the required minimum capacity will be 20 × 4 = 80 yd<sup>3</sup> in a

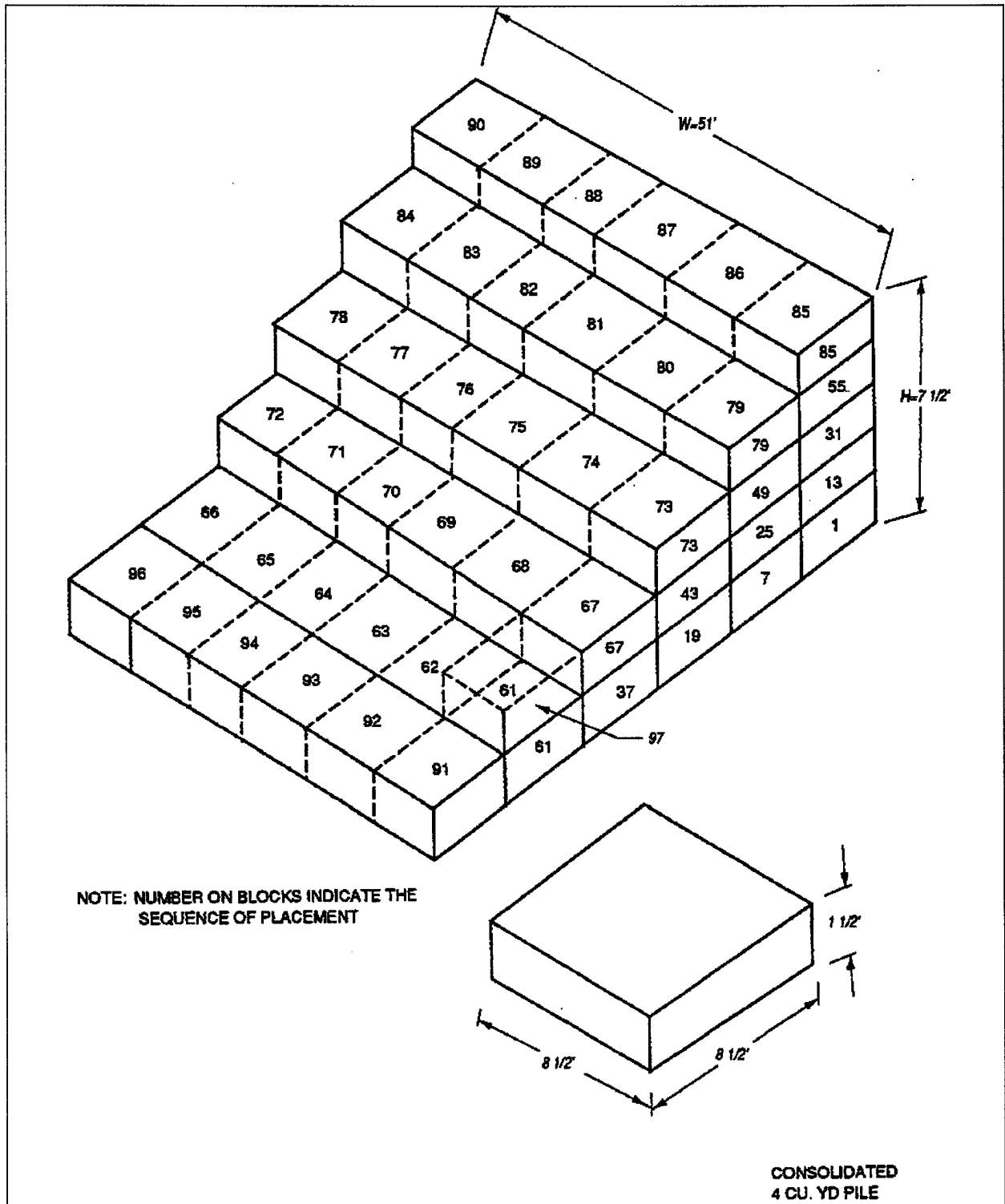

Figure 3-1. Stepped placement sequence and plant capacity, 7-1/2-ft lift height

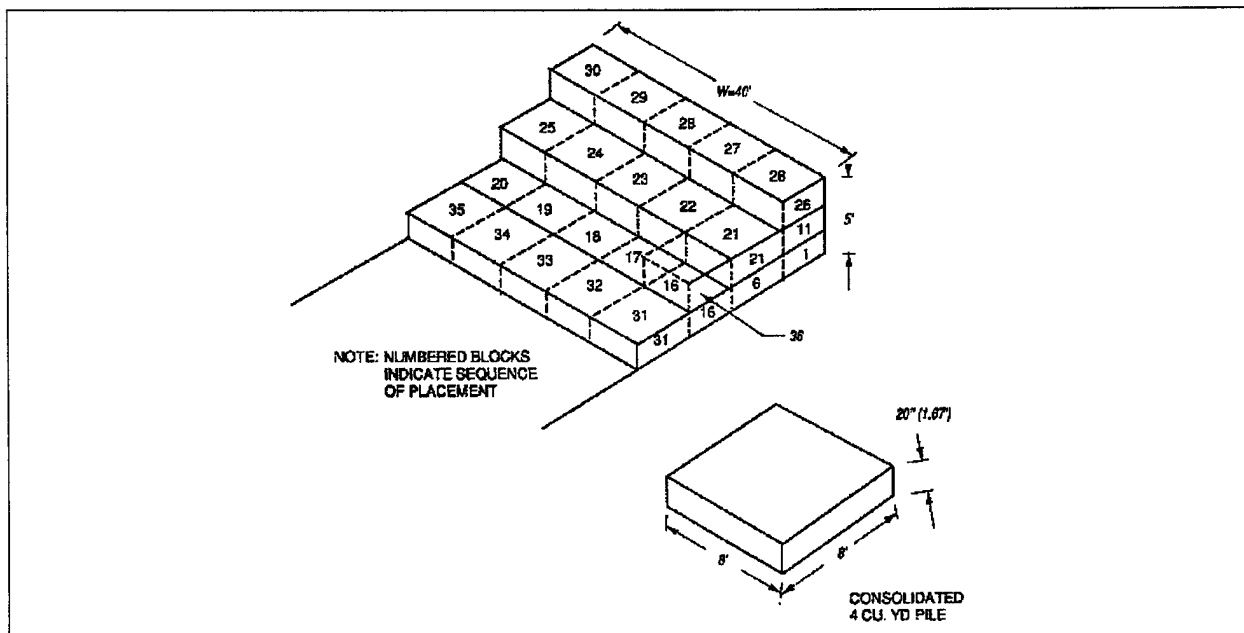

Figure 3-2. Stepped placement sequence and plant capacity, 5-ft lift height



2-hr period or 40 yd<sup>3</sup> per hour. The same results can be obtained from Equation 3-1.

(5) Other placing methods. If other placing techniques are likely to be used such as a pump or conveyor, the plant capacity has to be adequate to supply the unit at a rate near its rate capacity to avoid plugs or segregation. The capacity of the plant and placing equipment will have to be adequate to prevent cold joints in the placements. The capacity calculated for bucket placement may be used as a beginning point for plant capacity calculations.

*f. Conveying and placing considerations.* Historically, most concrete for Corps structures has been placed by crane and bucket. Recently, however, the preferred placing equipment has changed, and conveyors and pumps are being used to place an increasing amount of mass and structural concrete, respectively. Mixture proportions, conveying methods, and placing restrictions must be considered for each portion of the project during PED to assure that appropriate concrete is placed in each feature. For example, it is impossible to pump lean mass concrete with 75-mm (3-in.) maximum size aggregate, and therefore buckets, or conveyors must be used. The proportions of the concrete mixtures must meet the designer's requirements for strength, slump, maximum size aggregate, etc., and must be capable of being placed by the Contractor. The mixture proportions should not be altered to accommodate a Contractor's placing equipment if the designer's requirements would be compromised.

*g. Use of epoxy resins.* All epoxy resin shall be specified to meet ASTM C 881 (CRD-C 595). The type and grade for specific uses should be as follows:

Dowels in drilled holes	Type IV, Grade 3
Patching and overlays	Type III
Bonding new concrete to old	Type V
Crack injection	Type IV, Grade 1

Refer to ASTM C 881 for the correct "class" for use at the anticipated temperature of the surface of the hardened concrete. During cooler weather, the epoxy resin should be stored at room temperature for several days prior to use.

### 3-2. Special Studies

*a. General.* Often it will be necessary to conduct tests that extend in scope beyond those listed above. The need for such tests may develop as a result of the size or

complexity of a project, an unusual characteristic of the available cementitious materials or aggregates or the climatic conditions at a project site. The most commonly required studies are thermal studies followed by abrasion-erosion studies and mixer grinding studies. Such studies, when required, should be identified during the feasibility phase and funding and scheduling should be included in the project management plan. The results of these studies will be documented in the appropriate DM.

*b. Thermal studies.* During the PED for projects involving concrete structures, it is necessary to assess the possibility that temperature changes in the concrete will result in strains exceeding the strain capacity of the concrete. Although temperature control is generally associated with large mass-concrete structures, it should be noted that small, lightly reinforced structures may also crack when subjected to temperature extremes. Therefore, thermal studies are required for any important concrete structure. This may include, but not be limited to, dams, locks, powerhouses, and large pumping stations.

(1) Material properties needed for a thermal study. The following concrete material properties should be determined. Information on cost and time requirements for the following material properties tests may be obtained from CEWES-SC.

(a) Heat of hydration. The heat generated will depend on the amount and type of cementitious materials in the concrete. The heat of hydration is obtained experimentally and forms part of the basis for predicting the temperature rise and decline with time for a concrete (ASTM C 186 (CRD-C 229)).

(b) Adiabatic temperature rise. The temperature rise in concrete under adiabatic conditions is determined according to CRD-C 38. The cementitious material types and aggregates in the concrete so tested should be similar to those proposed for use in the structure.

(c) Thermal conductivity. Thermal conductivity is a measure of the ability of the material to conduct heat and may be defined as the ratio of the rate of heat flow to the temperature gradient. Numerically, thermal conductivity is the product of density, specific heat, and diffusivity.

(d) Thermal diffusivity. Thermal diffusivity is a measure of the facility with which temperature changes take place within a mass of material (CRD-C 37); it is equal to thermal conductivity divided by specific heat times density.

1 Feb 94

(e) Specific heat. Specific heat is the amount of heat required per unit mass to cause a unit rise of temperature, over a small range of temperature (CRD-C 124).

(f) Coefficient of thermal expansion. The coefficient of thermal expansion can be defined as the change in linear dimension per unit length per degree of temperature change (CRD-C 39, 125, and 126).

(g) Creep. Creep is time-dependent deformation due to sustained load (ASTM C 512 (CRD-C 54)).

(h) Strain capacity. The ultimate tensile strain capacity of concrete is determined by measuring the unit strain at the outer fibers of unreinforced beams tested to failure under both rapid and slow loading (CRD-C 71).

(2) Time of completion of thermal study. The thermal and mechanical properties of the concrete are very dependent on the mineralogical composition of the aggregates and the cement type used. Therefore, it is imperative that thermal studies not be undertaken until such time as the aggregate investigations have proceeded to the point that the most likely aggregate sources are determined, and the availability of cementitious material is known. If changes occur related to the aggregate source or the type of cementing material as a result of the Contractor exercising options, supply difficulties, or site conditions, it may be necessary to rerun a portion of the study to verify the earlier results. The initial study must be completed before plans and specifications are finalized.

(3) Temperature control techniques. All the temperature control methods available for consideration have the basic objective of reducing temperature rise due to all factors including heat of hydration, reducing thermal differentials within the structure, and reducing exposure to cold air at the concrete surfaces which would create a sharp thermal differential within the structure. The most common techniques, in addition to selection of slow heat-gain cementitious materials, are the control of lift thickness, placing interval, maximum placing temperature, and surface insulation. On very large structures, post cooling has been used (ACI 224R).

(4) Numerical analysis of temperature control techniques. The analysis of the various temperature control techniques to determine the combination best suited to a particular project may be done by computer using a finite-element analysis program. Interdisciplinary coordination between materials engineers, structural engineers, and construction engineers is essential to ensure that the complex numerical analysis is based on reliable concrete

and foundation properties and realistic construction techniques. Requests for consultation and assistance in performing numerical analysis should be made to CECW-EG. For structures of limited complexity, such as base slabs, satisfactory results may be obtained by the use of equations in ACI 207.4R.

*c. Abrasion-erosion studies.*

(1) General. Damage to the floor slabs of stilling basins due to abrasion by waterborne rocks and other debris is a constant maintenance problem on existing Corps projects. Abrasion-erosion on various projects has ranged from a few inches to 10 ft, and on occasion, severe damage has been noted after only a few years of operation. Hydraulic characteristics have a large effect on erosion and abrasion and should be considered in the design of spillways, conduits, and stilling basins.

(2) Test method. An underwater abrasion test method, ASTM C 1138 (CRD-C 63), is available to allow comparisons between materials proposed for use in stilling basins. Results of tests with several types of materials commonly thought to offer abrasion resistance suggest that conventional concrete of the lowest practical w/c and with the hardest available aggregates offer the best protection for new construction and for repair to existing hydraulic structures where abrasion-erosion is of concern. The abrasion tests should be performed to evaluate the behavior of several aggregate types for use in the stilling basin when more than one type is available.

(3) Application of test results. Because the costs of stilling basin repair is often substantial, it may prove feasible to import aggregate over a long distance for the concrete in the stilling basin slab if the aggregate in the project area is soft and the results of the abrasion test shows the potential for severe erosion. A discussion of stilling basin erosion should be included in the concrete materials DM. In some cases where hard aggregate is not economically available, silica-fume concrete with very high compressive strength may be used. Apparently, the hardened cement paste in the high-strength silica-fume concrete assumes a greater role in resisting abrasion-erosion, and as such, the aggregate quality becomes correspondingly less important.

*d. Mixer grinding studies.* During the investigation of an aggregate, it may be determined that the material degrades during handling and mixing. The tendency may be first noted as a high loss in the Los Angeles abrasion test (ASTM C 535 (CRD-C 145)). The result of this degrading is a significantly finer aggregate, and the result will be a

loss of slump during mixing which will result in an increase in water demand. Tests should be run by mixing the actual materials for a time similar to that anticipated on the project and the mixture proportion adjusted to reflect the finer grading of the aggregate.

*e. Concrete subjected to high-velocity flow of water.*

(1) General. Wherever concrete surfaces are to be subjected to water velocities in excess of 40 ft/s for frequent or extended periods, special precautions should be taken. Examples of such surfaces include conduits, sluices, tunnels, spillway buckets, spillway faces, baffles, and stilling basins.

(2) Quality of concrete. The concrete should have excellent workability and a low w/c as indicated in Table 4-1. The nominal maximum size of aggregate should be limited to 37.5 mm (1-1/2 in.) except for the formed portions of the downstream face of spillways for gravity dams where the maximum size aggregate may be up to 75 mm (3 in.). In many projects, a special layer of high-quality concrete, at least 1-ft thick, is specified to be placed over a lower quality concrete. This is done to keep the overall heat of hydration lower and for economy. The thickness of high-quality concrete adjacent to the critical surface should be the practical minimum that can reasonably be obtained with conventional placing equipment and procedures, but in no case less than 1 ft. The high-quality concrete should be placed integrally with the normal concrete.

(3) Construction joints. Wherever possible, construction or lift joints should be avoided in the water passages. Where joints cannot be eliminated, care must be exercised during the construction to obtain required alignment and smoothness within the specified tolerance. For example, grade strips should be used at the tops of lifts to guide the placement. After the concrete has been placed to grade, the strip should be promptly removed and the lift surface adjacent to the form should be smoothed to provide an even joint when the overlying lift is placed.

(4) Unformed surfaces. Unformed surfaces subjected to a high-velocity flow of water should be finished with a steel trowel finish with no abrupt edges, pits, or roughness.

(5) Formed surfaces. Formed surfaces should be given a Class AHV finish. See paragraph 5-4e for definitions of classes of finish.

*f. Unusual or complex problems.* Occasionally during design or construction, problems may be encountered which require specialized knowledge not available within the district or division organization. At this point, consideration should be given to obtaining the services of CEWES-SC. The selection of a consultant knowledgeable in concrete materials will be made with the advice of the Office of the Chief of Engineers, ATTN: CECW-EG.

## Chapter 4 Mixture Proportioning Considerations

### 4-1. Selection of Concrete Mixture Proportions

The selection of concrete mixture proportions is an important step in obtaining economical, durable concrete meeting design requirements. Depending on the types of structures, the concrete mixture proportions may be selected by the Government or by the Contractor. When mixture proportions are to be selected by the Government, the work will be accomplished by a division laboratory. Proportions for mass concrete or structural concrete are to be selected in accordance with ACI 211.1 (CRD-C 99) and other criteria as described in the following paragraphs of this chapter whether the work is done by the Government or the Contractor. Any new materials proposed for use after the initial mixture proportioning studies must be proportioned by the division laboratory or the Contractor's commercial laboratory using actual project materials in a new mixture proportioning study.

### 4-2. Basis for Selection of Proportions

*a. General.* The process of selecting concrete mixture proportions is a process of optimization of several desirable characteristics based on the project requirements. The characteristics to be optimized are economy, strength, durability, and placeability.

*b. Economy.* The primary reason for systematically determining mixture proportions is economy. The maximum economy can be achieved by minimizing the amount of cement used and where appropriate, by replacing portland cement with usually less expensive pozzolan or GGBF slag. Economy is also improved by using the largest nominal maximum size aggregate consistent with the dimensional requirements of the structures on the project, and available to the project.

*c. Strength.* Strength is an important characteristic of concrete but other characteristics such as durability, permeability, and wear resistance may be equally or more important. These may be related to strength in a general way but are also dependent on other factors. For a given set of materials, strength is inversely proportional to the w/c. Since the materials which make up concrete are complex and variable, an accurate prediction of strength cannot be based solely on the selected w/c but must be confirmed by tests of cylinders made from trial batches with the materials to be used on the project. Strength at the age of 28 days is frequently used as a parameter for structural design, concrete proportioning, and evaluation of concrete. When

mass concrete is used, the design strength is generally required at an age greater than 28 days, generally 90 days, because mixtures are proportioned with relatively large quantities of pozzolan or GGBF slag to reduce internal heat generation. The early strength of mass concrete will be low compared to that of structural concrete; therefore, mass concrete should be proportioned for an adequate early strength as may be necessary for form removal and form anchorage. A compressive strength of 500 psi at 3 days age is typical of that necessary to meet form-removal and form-anchorage requirements.

*d. Durability.* Concrete must resist deterioration by the environment to which it is exposed, including freezing and thawing, wetting and drying, chemical attack, and abrasion. Concrete must meet three requirements before it may be considered immune to frost action. It must be made with nonfrost-susceptible aggregates and a proper air-void system, and it must achieve an appropriate degree of maturity before repeated freezing and thawing is allowed to take place while the concrete is critically saturated. A proper air-void system is achieved by using an AEA. All exposed concrete placed by the Corps should be air entrained unless it is shown to be improper for a specific situation. The appropriate maturity exists when the concrete has a compressive strength of approximately 3,500 psi. Generally, durability is also improved by the use of a low w/c since this reduces permeability and the penetration of aggressive liquids.

*e. Placeability.* Placeability, including satisfactory finishing characteristics, encompasses traits described by the terms "workability" and "consistency." Workability is that property of freshly mixed concrete which determines the ease and homogeneity with which it can be mixed, placed, consolidated, and finished. Consistency is the relative mobility or ability of freshly mixed concrete to flow. Workability embodies such concepts as moldability, cohesiveness, and compactability and is affected by the grading, particle shape, and proportions of aggregate; the quantities and qualities of cementitious materials used; the presence or absence of entrained air and chemical admixtures; and the consistency of the mixture. The slump test, ASTM C 143 (CRD-C 5), is the only test commonly available to measure any aspect of the several characteristics included in the term "placeability." Moldability, cohesiveness, compactability, and finishability are mostly evaluated by visual observation, and, therefore, the evaluations are somewhat subjective. Typically, the Contractor will evaluate these characteristics from a different perspective than the government personnel involved, and within the Contractor's organization, the placing foreman may evaluate the placeability differently

1 Feb 94

than the finishing foreman. In general, the Contractor would like a high-slump mixture, while the Government desires a closely controlled slump. The key consideration must be a carefully proportioned concrete mixture which is placeable by the conveying and placing equipment to be used on the project without the addition of water at the placement site. Simply adjusting the water content of a mixture that was proportioned for placement by crane and bucket will not assure that it is pumpable or that such an adjustment will result in concrete that meets strength and durability requirements. Mass concrete mixtures are particularly susceptible to placing problems if not correctly proportioned. Care must be exercised to assure that the mortar content of lean, mass concrete mixtures is sufficient to provide suitable placing and workability. Water-reducing admixtures should not be used to reduce the paste content and the resulting mortar content of these mixtures to a level which causes the mixture to be harsh and unworkable.

#### 4-3. Criteria for Mixture Proportioning

*a. General.* The criteria for proportioning should be determined by the designer based upon the design and exposure requirements and conditions for the structure involved. Several sets of mixture proportioning criteria may be required for each structure to meet different design requirements. These criteria should be transmitted to the resident office as outlined in paragraph 6-2, "Engineering Considerations and Instructions for Construction Field Personnel."

*b. Proportioning criteria.*

(1) Maximum permissible w/c. The w/c of both structural and mass concrete should satisfy the requirements of Table 4-1.

(2) Structural concrete. For each portion of the structure, proportions should be selected so that the maximum permitted w/c is not exceeded and to produce an initial average compressive strength,  $f_{cr}$ , exceeding the specified compressive strength,  $f'_c$ , by the amount required. Where a concrete production facility has test records, a standard deviation shall be established. Test records from which a standard deviation is calculated:

- Shall represent materials, quality control procedures, conditions similar to those expected and changes in materials, and proportions within the test records shall not have been more restricted than those for the proposed work.

- Shall represent concrete produced to meet a specified strength or strengths  $f'_c$  within 1,000 psi of that specified for the proposed work.

- Shall consist of at least 30 consecutive tests or two groups of consecutive tests totaling at least 30 tests.

A strength test should be the average of the strengths of two cylinders made from the same sample of concrete and tested at 28 days or at some other test age designated. See ACI 318 for a more detailed discussion.

(a) Required average compressive strength  $f_{cr}$  used as the basis for selection of concrete proportions shall be the larger of the following equations using the standard deviation as determined in paragraph 4-3b(2):

$$f_{cr} = f'_c + 1.34s$$

$$f_{cr} = f'_c + 2.33s - 500$$

where  $s$  = standard deviation

(b) Where a concrete production facility does not have enough test records meeting the requirements above, a standard deviation may be established as the product of the calculated standard deviation and a modification factor from Table 4-2.

(c) When a concrete production facility does not have field strength test records for calculation of standard deviation, the required average strength  $f_{cr}$  shall be determined from Table 4-3.

(d) Evaluation and acceptance of concrete. The strength of the concrete will be considered satisfactory so long as the average of all sets of three consecutive test results equal or exceed the required specified strength  $f'_c$  and no individual test result falls below the specified strength  $f'_c$  by more than 500 psi. If the above criteria are not met, the resident engineer will notify the designer immediately so that the impact of the low strength may be evaluated. A "test" is the average of two companion cylinders, or if only one test cylinder is made, then a "test" is the strength of the one cylinder.

(3) Mass concrete. For mass concrete, the proportions selected for each quality of concrete for the project shall not exceed the maximum permitted w/c. Although there is typically a strength requirement for mass concrete, e.g. 2,000 psi at 1 year, the maximum-permitted w/c for

**Table 4-1**  
**Maximum Permissible Water-Cement Ratio (Notes 1 and 2)**

Water-Cement Ratios by Mass (for Concrete Containing Cementitious Materials Other Than 100% Portland Cement, See Note 3)

Location of Structure	Severe or Moderate Climate (Note 4)		Mild Climate, Little Snow/Frost (Note 4)	
	Thin Section (Note 5)	Mass Section	Thin Section (Note 5)	Mass Section
At the water line in hydraulic or waterfront structures where intermittent saturation is possible (includes upstream face of dams, downstream face in overflow sections on dam where spillage occurs once per year or more often, and exposed surfaces of lock walls)	0.45	0.50	0.55	0.60
Interior of dams and lock walls and interior of other large gravity structures where use of two classes of concrete is practical	--	0.80	--	0.80
Ordinary exposed structures, downstream face of nonoverflow section of dams, downstream face in overflow section where frequency of overflow is less than once per year.	0.60	0.60	0.60	0.65
Complete continuous submergence in water after placement "in the dry" (includes upstream face of dams below minimum pool elevation)	0.60	0.65	0.60	0.65
Concrete deposited in water	0.45	0.45	0.45	0.45
Pavement slabs on ground:				
Wearing slabs	0.50	--	0.55	--
Base slabs	0.60	--	0.60	--
Exposure to sulfate ground water or other aggressive liquid or salt	0.45	0.45	0.45	0.45
Concrete subjected to high (more than 40 ft/s) velocity flow of water	0.45	0.45	0.45	0.45
Stilling basins (for flood control and other high-velocity flow structures)	0.45	0.45	0.45	0.45

Note 1. For all concrete placed in or exposed to seawater, the w/c should be reduced 0.05 below values shown in the table but not lower than 0.45.

Note 2. Mixtures should be proportioned by the division laboratory at the maximum specified slump and air content. They should also be proportioned at w/c's 0.02 less than the value shown in the table to allow for batching variability in the field.

Note 3. Where cementitious materials in addition to portland cement are used, the water-cementitious material ratio required is that which would be expected to give the same level of compressive strength at the time the concrete is exposed to the design environment as would be given by a mixture using no cementitious material other than portland cement.

Note 4. See Figure 4-1.

Note 5. Largest dimension is 12 in. or less.

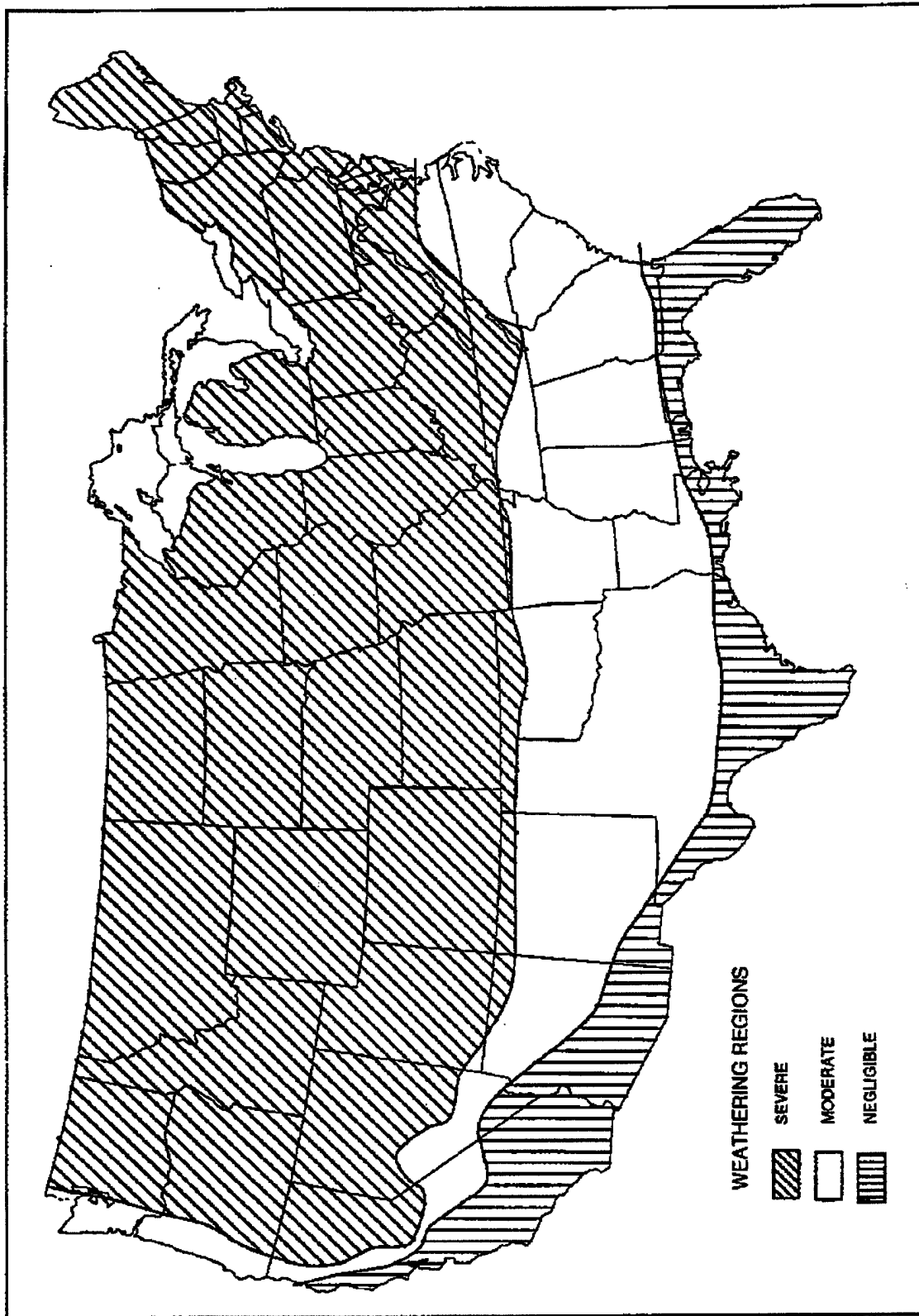

Figure 4-1. Location of weathering regions\*

\*Taken from Figure 1, ASTM C 33 (CRD-C 133).

**Table 4-2**  
**Modification Factor for Standard Deviation**

No. of Tests <sup>1</sup>	Modification Factor for Standard Deviation
Less than 15	See Table 4-3
15	1.16
20	1.08
25	1.03
30 or more	1.00

<sup>1</sup>Interpolate for intermediate numbers of tests.

**Table 4-3**  
**(See ACI 318, Table 5.3.2.2)**

$f'_c$	$f_{cr}$
Less than 3,000 psi	$f'_c + 1,000$
3,000 - 5,000 psi	$f'_c + 1,200$
More than 5,000 psi	$f'_c + 1,400$

acceptable durability will often have a corresponding strength in excess of this value when the mixture meets the criteria in Table 4-1. Concrete that will be subjected to repeated freezing-and-thawing cycles while critically saturated with water must have developed a strength of about 3,500 psi before being allowed to freeze and thaw. If the maximum values in Table 4-1 are not low enough to ensure this strength under the anticipated environmental conditions and required duration of curing and protection, then the w/c (or water-cementitious material ratio) must be lowered or the required duration of curing and protection increased. To ensure that no more than 2 in 10 tests fall below the strength corresponding to the required w/c, the required average strength is determined as follows:

$$f_{cr} = f'_c + ts$$

where

$t = 0.854$  for 30 tests or less;  $0.842$  if more than 30 tests are available

$s =$  standard deviation

Where results of fewer than 30 tests are available, the average strength should exceed  $f'_c$  by 600 psi. Mixtures will be proportioned to meet the required average strength except where the required w/c provides strength in excess of the design strength. The basis for the equation and the computation of standard deviation is found in ACI 214.

(4) Nominal maximum aggregate size. The nominal size of aggregate recommended for various types of construction is listed in Table 2-2.

(5) Water content. The water requirement is a function of the nominal maximum size aggregate, the aggregate grading, the required air content, and the required slump. Given these parameters, the approximate starting



water content for mixture proportioning studies can be determined from Table 6.3.3 of ACI 211.1. In the range of normal concretes, a given combination of aggregates requires an approximately constant amount of water per cubic yard of concrete for a given slump regardless of the w/c. In mass concrete, the water requirement is maintained low by the use of a large nominal maximum aggregate size and by the close control of grading.

(6) Cement content. The quantity of cementitious materials will be determined based on the maximum w/c and the estimated water requirement selected for the portion of the structure involved. In mass concrete, the usual low water requirement results in a low cement requirement which is one of the means of reducing the amount of heat developed by hydration.

(7) Proportioning with pozzolans or GGBF slag. Major economic and temperature rise benefits are derived from the use of pozzolans, blended cement, or GGBF slag. Therefore, concrete should be proportioned with the maximum amount of these materials that will satisfy the structural, durability, and other technical requirements as appropriate and be economically beneficial. Use of pozzolans and GGBF slag in mass concrete provides a partial replacement of cement with a material which generally generates less heat at early ages. The effects of these materials on the properties of freshly mixed concrete vary with the type and fineness; the chemical, mineralogical, and physical characteristics of the material; the fineness and composition of the cement; the ratio of cement to pozzolan or GGBF slag; and the total mass of cementitious material used per unit volume of concrete. Often, it is found that the amount of mixing water required for a given concrete slump and workability is lower for mixtures containing pozzolans or GGBF slag than for those containing only portland cement. Air-entraining admixture needs may be reduced by up to approximately 20 percent or increased by over 60 percent depending on the characteristics of the pozzolan or slag. Therefore, it is important to evaluate the pozzolan or slag using representative material samples during the laboratory mixture proportioning study. The dosage rate of chemical admixtures should generally be based on the total amount of cementitious material in the mixture. The proportion of cement to pozzolan or GGBF slag depends on the strength desired at a given age, heat considerations, the physical and chemical characteristics of both cement and cement replacement material, and the cost of respective materials. As a safety precaution against the possibility of increased alkali-silica reaction in concrete containing small (pessimum) amounts of certain pozzolans, the quantities of fly ash and natural pozzolan used in concrete should not be

less than 15 percent by mass of total cementitious material. ASTM Type I (PM) should not be specified because of the possibility that it would contain the pessimum amount of pozzolan. The selected replacement quantities should be discussed in the concrete materials DM. This guidance will then be used by the division laboratory to proportion project concrete mixtures using materials submitted by the Contractor. Due to differences in their densities, a given mass of pozzolan or slag will not occupy the same volume as an equal mass of portland cement. The determination of w/c, by absolute volume equivalency, when pozzolan or slag is used is described in ACI 211.1.

#### 4-4. Government Mixture Proportions

*a. General.* When concrete is being placed in a structure requiring the use of the guide specification for mass concrete, CW-03305, the mixture proportions are determined at a division laboratory using materials provided by the Contractor which are representative of those to be used in the project. Those division laboratories authorized to test concrete materials are listed in ER 1110-1-8100, "Laboratory Investigations and Materials Testing." Proportions for mass concrete or structural concrete are to be selected in accordance with ACI 211.1 and other criteria as described in the following paragraphs of this chapter.

*b. Coordination between project, district design personnel, and the division laboratory.* The criteria for proportioning the concrete mixtures to meet the requirement of each type of concrete required in a project is provided to the project personnel in detail in paragraph 6-2, "Engineering Considerations and Instructions for Field Personnel." The project personnel should notify the division laboratory of the required proportioning criteria at the time that the samples are transmitted from the Contractor to the laboratory. Much time is lost when several tons of aggregate and cement are delivered with no previous notification by Corps project personnel that the material was coming and no indication of proportioning criteria required. Since the specification indicates when the Contractor should expect starting mixtures after he submits his materials samples, close coordination between the Corps personnel on the project and in the division laboratory is essential, not only to assure that mixture proportions meet the project needs but also to avoid delay claims by the Contractor. The "Guide Specification for Mass Concrete," CW-03305, requires the designer or specification writer to state the number of days prior to the start of concrete placing that materials for mixture proportioning studies must be submitted to the division laboratory. Timely submittal of these materials is the responsibility of the project office.

*c. Sampling of materials.* Guide Specification CW-03305 outlines the procedure by which samples are to be taken by the Contractor for mixture-proportioning studies. The Contractor is required to test the aggregates for quality and grading before shipment to the laboratory. These samples are to be taken under the supervision of the Contracting Officer. It is important that this requirement is followed. The most common problems arising from lack of attention to these details are samples arriving at the division laboratory which do not meet project grading requirements or are not representative of the materials that are actually to be used or both. Both problems may lead to delays of concrete placements or the necessity for considerable field modification of the mixture proportions. The division laboratory should test submitted materials to determine that they meet specification requirements prior to using them to develop mixture proportions. The need for the samples that are submitted to be representative extends to all the materials in the concrete, including cement, pozzolans, GGBF slag, and chemical admixtures.

*d. Data supplied by division laboratory to project.* For each type of concrete required on the project, the division laboratory should select initial proportions that satisfy the mixture criteria provided by the project personnel. The batch amounts of each constituent in a cubic yard should be reported in the saturated-surface dry (SSD) condition. The amounts of chemical admixtures such as air-entraining and water-reducing admixtures will be reported as fluid ounces per 100 lb of cementitious materials. Strength data will be provided for each type of concrete to the extent that it is available by the time the proportions are transmitted to the project. As a minimum, 24-hour, 7-day, 28-day, and design-age strengths should be available prior to the start of placement. A regression analysis of accelerated strength at a later age should be computed to determine the correlation coefficient and 95 percent confidence limits (see ACI 214.1R). The mixture proportions provided for each type of concrete should include a family of curves of strength versus water-cementitious materials ratio at various ages.

*e. Adjustment of government mixture proportions.* The mixture proportions provided by the division laboratory provide starting mixtures meeting the project criteria. However, when these proportions are used in the first batches of concrete produced by the Contractor's plant, it is not uncommon for the concrete to be deficient in one or more of the control parameters of the specifications. The most common deficiency is in the slump. The laboratory will report mixture proportions based on the aggregates in an SSD condition. A common cause of an increase in slump is the failure to properly adjust for free moisture in

the aggregate, particularly the fine aggregate. Low slump is normally not a problem if concrete is batched and mixed on site unless rapid slump loss occurs. Variations in the chemical or physical properties of cement or pozzolan are the most common causes of rapid slump loss although transporting and placing operations may also contribute to the problem. Assuming all materials and transporting and placing equipment and operations meet specification requirements, the most practical solution for dealing with rapid slump loss is to increase the slump at the mixer to the degree necessary to have a slump at the forms which is within the specification limits. The w/c should be maintained constant if the slump is increased. Care should be taken to determine if the addition of cementitious materials necessary to maintain a constant w/c will detrimentally affect the thermal properties of the concrete or nullify results of a thermal stress analysis. Adjustments of the dosage of air-entraining admixture by the Contractor are required as needed to maintain air contents within the specified range. As gradings of individual coarse aggregate size groups change, the proportions of the size groups should be adjusted so that the combined coarse aggregate grading approximates the maximum density grading. The maximum density grading may be computed using Equation A5.3 in ACI 211.1. As the combined coarse aggregate grading approaches the maximum density grading, the void content of the mixture is reduced and more mortar is available for placeability, workability, and finishability. Solution of the percentage of each size group can usually be done such that the combined coarse aggregate grading is generally within 2 or 3 percent of the maximum density grading. Trial and error may be used in selecting the percentage of each size group necessary to produce a combined coarse aggregate grading which approximates the maximum density grading; however, proprietary computer programs are also available. Contact CECW-EG for the available computer programs. Adjustments in the percentage of fine aggregate is less common, but slight changes may be necessary to compensate for significant changes in grading over an extended period of production. Adjustments to government mixture proportions are to be made by government personnel. Changes in aggregate and water batch weights to compensate for free moisture in aggregates are made by the Contractor and are not considered adjustments to mixture proportions. Division laboratory personnel should be present and prepared to make adjustments in mixture proportions when the Contractor initiates concrete production on a project and after periods of batch plant shutdown such as winter shutdowns or prolonged strikes. Procedures for making adjustments are given in ACI 211.1 and will be made on an absolute volume basis. The mortar volume should remain constant and changes in any one mortar constituent such as water, fine

1 Feb 94

aggregate, air, or cementitious material content should be compensated for by changes in another mortar constituent without changing the w/c. It is important that adjustments to the government mixture proportions be made during plant shake-down, before any concrete is placed in the structure.

#### 4-5. Evaluation of Contractor-Developed Mixture Proportions

*a. General.* The Contractor should submit his mixture proportions for review prior to initiating concrete placement. The mixture proportions should be developed in accordance with ACI 211.1.

*b. Reviewing contractor submittals.*

(1) Minor structures. When the concrete being placed is in a minor structure, the concrete will almost always be supplied by a ready-mixed concrete producer. The mixture proportions will normally be submitted as a tear sheet from the producer's catalog or as a data sheet from a local commercial laboratory which was retained at some time to prepare a series of mixtures for the producer to market. Review of these submittals should include a determination that the type of cement used, the air-entraining admixture, and the aggregate source are the same as will be used on the project and that each constituent meets the specification requirements. Test cylinder data submitted by the Contractor should not be more than 180 days old. The w/c,  $f'_c$ , and  $f_{cr}$  must satisfy the contract requirements.

(2) Cast-in-place structural concrete. Because the structures for which this guide specification is applicable are important structures involving water control and power production, the specification requirements provided to the Contractor for proportioning the concrete mixtures are similar to those followed by the division laboratory when the Government is required to proportion the mixture. The

review of the submitted mixture proportions should assure the following:

(a) Cementitious materials. The submitted mixture must be proportioned using the same cementitious materials as will be used in the project. This should include type, manufacturer, mill of origin, and time of manufacture. If a pozzolan is to be used, the Contractor's submittal should state whether the percentage of replacement is based on mass or volume.

(b) Aggregate. The aggregate used in proportioning the mixture should represent the current production of whichever source the Contractor selects. Quality tests and grading test results should be submitted showing that the aggregates meet specification requirements. Batch amounts for aggregates should be listed in the SSD condition unless some other basis is agreed on.

(c) Admixtures. The admixtures used in proportioning the mixture should be from the same stock that the Contractor has purchased for use on the project or from the current stock of the ready-mix producer for the project. All admixtures should meet the project specifications and the dosages should be listed.

(d) Test results. The w/c and required strength test results should be reviewed to assure that they match project requirements. Air contents and slumps should be at the upper limits of the specification requirements.

(e) Placeability. The mixtures must be proportioned to provide the necessary placeability for the conveying and placing equipment that the Contractor proposes to use. For instance, concrete that will be pumped may be proportioned differently than concrete that will be delivered by crane and bucket, or directly from the truck mixer, or by tremie pipe, etc.

## Chapter 5 Preparation of Plans and Specifications

### 5-1. Selection of Guide Specification for Concrete

*a. General.* The use of guide specifications is prescribed by ER 1110-2-1200, "Plans and Specifications." Guide specifications for concrete are used to ensure that the requirements for concrete construction for all projects will be consistent and that the concrete produced will be uniform in properties, of required quality, and economical. There are several guide specifications available for concrete placed on Corps of Engineers civil works projects. These guide specifications should be used in every case, with the only exceptions being for situations requiring the use of special concrete applications not covered in guide specifications. Changes should be limited to minor technical changes unless approved in the DM. No changes should be made in the format. The completion of project specifications will be based on the approved concrete materials DM.

*b. Guidelines for selection.* If the project for which specifications are being prepared involves mostly mass concrete as in a lock or dam, Guide Specification CW-03305, "Mass Concrete," should be used. For an important structure, other than a lock or dam, such as a powerhouse superstructure, bridge, fish hatchery complex, visitor center, tunnel lining, major pumping station, intake structure, or other structures appurtenant to embankment dams where reinforced concrete is required, the Guide Specification CW-03301, "Cast-in-Place Structural Concrete," should be used. If the project is a recreational site, road relocation, or other project involving small amounts of concrete in structures such as culvert headwalls, comfort stations, residences, or low headgate structures, the Guide Specification CW-03307, "Concrete (for Minor Structures)," should be used. There may be instances where more than one guide specification will be necessary on the same project. When this is the case, it will be important to precisely outline in the specification and on the plans which specification applies. The Guide Specification CW-03362, "Preplaced Aggregate Concrete," is chiefly applicable for repairs to damaged or deteriorated concrete structures.

*c. Use of state specifications.* The specifications of a state agency, such as a highway department, may be substituted for all or parts of the Guide Specification CW-03307, "Concrete (for Minor Structures)," when the work being accomplished will ultimately be operated or maintained or both by the state in which it is located or when savings will result due to the familiarity of local contractors with the more usual specifications. One area where savings may result would be in the substitution of

state requirements for aggregate quality and grading when it is known that this is the material produced in greatest quantity by local aggregate producers.

*d. Use of abbreviated specifications.* For very small concrete placements, it may be justifiable to use an abbreviated specification of one or two pages in length produced by editing a state specification or the Guide Specification CW-03307, "Concrete (for Minor Structures)." Such abbreviated specifications should be considered when the only concrete on the project is being placed in picnic table bases, light bases, small culvert headwalls, or other small noncritical structures.

### 5-2. Guide Specification "Concrete (for Minor Structures)," CW-03307

*a. General.* This guide specification provides requirements for concrete of adequate quality for minor structures. All concrete must be air-entrained.

*b. Cementitious materials options.* The intent of the Guide Specification CW-03307, "Concrete for Minor Structures," is to allow the Contractor maximum flexibility to use locally available cementitious materials. Accordingly, the optional use of blended hydraulic cement would be allowed if such material is reliably available in the project area. Low-alkali portland cement would be a specified option if locally available aggregates are known or suspected to be potentially deleteriously alkali reactive. Increased resistance to sulfate attack may be obtained with blended hydraulic cement by specifying a suffix of MS following the type of designation. All specifications must allow the use of pozzolan; reference paragraph 2-2 of this manual.

*c. Selection of compressive strength.* The required specified compressive strength will be determined by the structural designer. Normally, a specified compressive strength ( $f'_c$ ) of 3,000 psi at 28 days is a reasonable and attainable value in rural areas and remote locations where many of the minor structures are located. Higher values may be specified if required. The value specified should be confirmed as adequate by the designer in every case. If durability is a limiting design factor, the maximum w/c shall normally be limited to 0.50. Lower values may be specified if required. See Table 4-1.

*d. Selection of nominal maximum aggregate size.* The largest nominal maximum size aggregate incorporated into the minor structures intended to be covered by this specification is 37.5 mm (1-1/2 in.). If thin sections are involved or there is interference from reinforcement,

1 Feb 94

19.0-mm (3/4-in.) nominal maximum size aggregate will be specified. Generally, for sections 7-1/2 in. or less in width, heavily reinforced floor and roof slabs, and all sections where space is limited and surface appearance is important, 19.0-mm (3/4-in.) maximum size aggregate will be specified. For sections over 7-1/2 in. wide and in which the clear distance between reinforcement bars is at least 2-1/4 in., the maximum size aggregate specified shall be 37.5 mm (1-1/2 in.).

*e. Finish requirements.* This guide specification requires a floated finish on unformed surfaces with an optional paragraph for a steel-trowel finish. A float surface will be adequate for most of the concrete covered by this specification; however, for shop or office floors, other areas where frequent cleaning is necessary, and areas to be painted or covered by other floor coverings, a steel-trowel finish should be specified.

### 5-3. Guide Specification "Cast-in-Place Structural Concrete," CW-03301

*a. General.* The Guide Specification CW-03301, "Cast-in-Place Structural Concrete," is for use on important reinforced structures; therefore, it is not intended to be edited except to select available options. Guidance for the selection of the options is provided in the following paragraphs. Any substantial departures from the guide specifications must be included in the appropriate DM for approval.

*b. Testing of cementitious materials.* Essentially, there are two options provided in the guide specification to define the required preconstruction testing or certification of cement and pozzolan. The procedures to be followed when cements and pozzolan are to be sampled and tested by the Government prior to their use in the construction to determine compliance or noncompliance with the specifications are specified. The Contractor may also elect to use cement or pozzolan from a source which has been prequalified by the Government. These guide specifications define those conditions that must be met for the acceptance of cementitious materials on the basis of a manufacturer's certification of compliance accompanied by mill test reports. The decision to use the more restrictive paragraphs should be based on the criticality of the structure involved. Generally, government testing will be used for powerhouse structures and any structures appurtenant to locks and dams that control water, to include tunnel lining, large gate structures, intake structures, stilling basins, and major bridges. Certification accompanied by mill test reports, will suffice for fish hatchery structures, maintenance structures,

and others not specifically designed for the control of water downstream. If cementitious materials are to be tested by the Government, the U.S. Army Engineer Waterways Experiment Station (ATTN: CEWES-SC) should be contacted for a current cost. Cement or pozzolan sources that are prequalified must also be periodically tested during construction at CEWES-SC, and the tests must be funded.

*c. Admixtures and curing compounds.* Optional paragraphs of CW-03301 provide for air-entraining admixtures, water-reducing admixtures, and curing compounds to be accepted on the basis of either preconstruction testing by the Government or certifications of compliance submitted by the Contractor. The decision as to which option to use for the admixtures or curing compounds should be based on the criticality of the structures involved and on past experience with the products and suppliers in the project area. If problems have occurred on other projects, then the product should be tested by the Government to assure compliance.

*d. Testing of aggregate.* The division laboratory which will receive the samples should be contacted and the sample sizes and the number of days required to evaluate the aggregates established. The number of days listed for the testing of the aggregate should be chosen to be long enough to provide for unforeseen delays at the laboratory so that the Contractor claims which would result if the evaluation were delayed can be avoided.

*e. Nonshrink grout.* The type(s) of nonshrink grout to be used are to be selected by the Contractor in accordance with ASTM C 1107 (CRD-C 21). The decision as to the type of nonshrink grout should be based on the application, exposure conditions, and the manufacturer's recommendations. If severe exposure conditions are anticipated, testing should be performed on the types of nonshrink grouts specified to assure their adequacy. If the Contractor selects a Grade A prehardening volume adjusting grout, the space to be grouted must be confined on all sides.

*f. Cementing materials option.* The inclusion or exclusion of available cementing materials options in the preparation of project specifications must be based on and supported by the results of the investigations outlined in Chapter 2 of this document. The guide specifications provide, as options, those types of portland cement and blended hydraulic cements generally used for cast-in place structural concrete, and the Contractor should be allowed the widest choice possible subject to specific suitability and availability. The Contractor must be allowed the option of using fly ash.

*g. Specifying aggregate.* The coarse aggregate gradings and aggregate quality to be specified in the guide specifications must be based on and supported by the investigations outlined in Chapter 2 of this document. The ASTM C-33 (CRD-C 133) sizes selected as options will depend on the nominal maximum size aggregate available and appropriate for use in the various project structures as specified in the guide specifications. The selection of the nominal maximum size coarse aggregate will also be based on the aggregate investigation. If technically feasible, the size number selected will correspond to those available in whatever commercial aggregate sources are listed. Note that size No. 1, 2, 3, and 357 will not be specified since the nominal maximum size represented by these designations exceeds 37.5 mm (1-1/2 in.), and size No. 7 and 8 are for "pea gravel" sizes not normally used in structural concrete.

*h. Strength.* The paragraph in part one of CW-03301 entitled "Design Requirements" lists the strengths required for the various portions of the structure. It is necessary for the designer to determine what strength is required and the age at which the strength is needed or the design age. Typically, this is 28 days; however, if construction or operational loads are not anticipated for some longer period of time, economies can be realized in the concrete by proportioning concrete mixtures to attain design strengths at later ages such as 90 or 180 days. It should be noted, however, that durability requirements might result in higher strengths due to the w/c requirements.

*i. Batch-plant capacity.* The computation of batch-plant capacity for cast-in-place structural concrete will be based on an assessment of the likely placement sequence on the project. See Chapter 3 of this manual for guidance in selecting the batch-plant capacity.

*j. Batch-plant controls.* The batch-plant control system specified for cast-in-place structural concrete may be partially automatic, semiautomatic, or automatic. The semiautomatic plant should be provided with interlocks and recorders if the project includes major structures. If technically feasible, the batch-plant requirements should coincide with the equipment which is locally available. See Chapter 3 of this manual for more guidance on selection of batch-plant type.

*k. Concrete deposited in water.* The optional paragraph, CW-03301, entitled "Placing Concrete Underwater" will be included in all specifications for projects which include underwater placement of concrete. The decision to use underwater placement in lieu of dewatering must be discussed in the Concrete Materials DM.

*l. Finishing unformed surfaces.* Subparagraphs are provided in paragraph 8-3 entitled "Finishing" to provide an abrasive aggregate finish, a broom finish, or a bonded two-course floor. The abrasive aggregate finish or broom finish should be applied in those areas where slippery floor surfaces would present a problem. A bonded two-course floor would be an option for a warehouse area or other surface exposed to heavy loads, traffic, and abrasion.

*m. Sheet curing.* Sheet curing may be specified for horizontally finished surfaces such as roof slabs, floors not subject to public view, or floors that are to be covered with tile or resilient flooring by listing the areas to be so cured. Polyethylene film shall not be used unless it is coated with burlap or other materials.

*n. Areas to be painted.* If the project includes large areas of concrete surfaces to be painted, they should be impervious sheet cured, moist cured, or cured with a chlorinated rubber base curing compound specified by reference to ASTM C 309, (CRD-C 304) Class B.

*o. Finishing formed surfaces.* Optional subparagraphs are included in the paragraph entitled "Formed Surfaces" to provide for various finishes to achieve desired architectural effects. The selection of the optional paragraphs will depend on architectural requirements. The architectural drawings should be consulted when preparing this paragraph. When extensive use of architectural finishes are planned, guidance for expanded specifications may be obtained from CECW-EG. ACI 303R is an excellent reference.

*p. Floor tolerance.* The optional paragraph in part 3, CW-03301, entitled "Slab Tolerance by F-number System" may be used as this technology becomes available in the local project area or immediately as a very flat floor is necessary. Reference the discussion in Chapter 8 of this manual before specifying the F-number system.

#### **5-4. Guide Specification "Mass Concrete," CW-03305**

*a. General.* This specification is intended for large civil works structures of predominately mass concrete. These structures are almost always important water control structures. This guide specification is the most restrictive of the guides for concrete construction and is intended to be used unedited except for selecting available options, unless a deviation has been approved in advance in the materials DM. Guidance for the selections of some of the options is provided in the following paragraphs.

b. *Sampling of aggregates.* To complete the paragraph in part 2, CW-03305, entitled "Aggregates," CRD-C 100 and the concrete materials DM should be consulted. The division laboratory that will receive the samples should be contacted, and the sample sizes and the number of days required to evaluate the aggregate confirmed and established. The number of days listed for the testing of the aggregate should be chosen to be long enough to provide for unforeseen delays at the laboratory so that the contractor claims which could result if evaluation were delayed can be avoided. It may be necessary to have some overlap in the time required for aggregate quality testing and the time required for mixture proportioning studies so as to not delay the start of construction. Close coordination between the project office and the division laboratory is important.

c. *Mixture proportioning studies.* Mixture proportioning studies will be completed at the assigned Corps of Engineers division laboratory. It is necessary to insert the address of the assigned division laboratory in Guide Specification CW-03305. The quantities required for the mixture proportioning studies will be furnished by the laboratory. Materials shipped to the laboratory should be accompanied by the required contractor's quality and grading test reports. Government quality tests should be performed in the division laboratory as judged necessary, prior to mixture proportioning studies.

d. *Testing cementitious materials.* Current costs for testing hydraulic cement, pozzolan, and GGBF slag should be obtained from the Waterways Experiment Station (ATTN: CEWES-SC). The cost for testing of cementitious materials will be included in Guide Specification CW-03305. Samples and funding of testing is required even though prequalified sources are selected.

e. *Surface requirements.* Several classes of finish are available in CW-03305 to be employed as described in the following paragraphs.

(1) Class A finish. Class A finish is specified for surfaces of structures where excellent appearance at close range is important. Examples of Class A finish include exterior walls of buildings of all types such as superstructures of powerhouses and pumping plants, interior surfaces of such walls when no other finish treatment is to be added, floodwalls, and parapets, and other ornamental structures on dams. The required form materials for Class A finish are limited to new, well-matched tongue-and-groove lumber or new plywood panels as specified in the paragraph entitled "Materials" in Part 2 of CW-03101. The forms should be clean, tightly set, and securely anchored to prevent grout leaks.

(2) Class AHV finish. Class AHV is for finishes exposed to a high-velocity (greater than 40 fps) flow of water. Examples of this type of surface include lock filling and emptying ports, lock culverts, outlet works, and spillway tunnels. The forms should be strong and held rigidly and accurately to the specified alignment. The materials for forms are the same as Class A finish except that steel forms may be used.

(3) Class B finish. This finish is specified for permanently exposed surfaces where excellence of appearance treatment is not as paramount. Examples include concrete dams and appurtenances (except where Class A finish is required), retaining walls, floodwalls, exposed surfacing of culverts, and outlet works.

(4) Class C finish. This finish is specified for areas that are not normally exposed to public view but will not be permanently covered with backfill. Examples include machinery rooms and interior passageways in large projects.

(5) Class D finish. This finish is specified for concrete surfaces where roughness and irregularities are not objectionable. Examples include bulkhead faces of monoliths in mass concrete structures and surfaces against which backfill will be placed. The chief requirement of the form is that it be watertight.

(6) Absorptive form lining. Absorptive form lining *should not be specified*. Numerous problems have resulted due to the use of absorptive form linings: small air bubbles remaining immediately below a thin surface skin of mortar, form lining sticking to concrete surfaces, and in general, the results have not justified the extra cost.

f. *Appearance.* The paragraph in part 3 entitled "Curing and Protection" of CW-03305, "Guide Specification for Mass Concrete," provides for those surfaces on which discoloration would be aesthetically undesirable and therefore need to be removed. The surfaces are those permanently exposed to view by the general public. In areas where the only available curing water is likely to stain or where aggregate impurities contribute to staining, it may be economically infeasible to prevent or remove all staining, and staining should be removed only on those surfaces constantly exposed to public view on which staining would be aesthetically troublesome.

g. *Cementitious materials option.* The inclusion or exclusion of available cementing materials options in the preparation of project specifications must be based on and supported by the results of the investigation outlined in Chapter 2 of this manual. The guide specification provides

for those types of portland cement and blended hydraulic cements generally used for mass concrete and available in the project area. Consult the materials DM for those cementitious material options which should be allowed. The use of fly ash will be permitted.

*h. Bid schedule for cementitious materials options.* Provisions should be made in the bid form for optional bidding on all the available and acceptable cementitious materials. The estimated quantities of portland cement, blended hydraulic cement, and GGBF slag should be expressed in units of mass. The quantities may vary between the various cements due to differences in required mixture proportions and density. The estimated quantities of pozzolans should be expressed in units of solid volume (cubic feet). This allows for variations in density dependent on the source selected by the Contractor. The estimated quantities of both cement and pozzolan should be derived from information gained in the preparation of preliminary mixture proportions during the preparation of the concrete materials DM.

*i. Retarder.* The Contractor may use a retarder at his option except in areas where retardation is considered to be detrimental. A retarder is appropriate when uncooled concrete is to be placed in very hot weather and the placing schedule is such that a danger of cold joints exists or problems in finishing may be anticipated. Retarders are also applicable to special structures in which revibration will be used to ensure low permeability.

*j. Water reducers.* The mandatory use of WRA's should be restricted to locations where there is an economic advantage to the Government. A Contractor's request to use a WRA in structural concrete should be approved unless its use is harmful in a given situation. The material should meet the requirements of ASTM C 494, (CRD-C 87) Type A or D, unless retardation would be detrimental to the work, in which case only Type A should be specified. Since the economic benefits resulting from the use of an admixture usually cannot be evaluated until the Contractor has made his choice of materials, the bidding schedule should include a split bid for a WRA. The first item includes for mobilization and demobilization costs of storing, dispensing, and recording the admixture. When the laboratory evaluation indicates no economic benefit from use of the admixture, it is not necessary to approve its use.

*k. Fine aggregate grading requirements.* Fine aggregate grading is a major factor affecting the unit water requirement, fine aggregate-coarse aggregate ratio, and cement content of a concrete mixture. That portion of the fine aggregate finer than the 150- $\mu$ m (No. 100) sieve has the

most pronounced effect on these factors. While it is possible to proportion a workable normal strength concrete mixture using most naturally occurring sand deposits, those gradings that fall within the limits listed in the guide specifications are more practical, generally requiring less cement and water for adequate workability. Beneficiation of the natural deposits can be accomplished by use of equipment which will reject a specific size portion or which will blend in a finer sand will usually be cost effective. Most natural river sands are deficient in the sizes finer than the 150- $\mu$ m (No. 100) sieve. This fine sand is often available and used in local asphaltic concrete paving mixes. The finess modulus (FM) is most useful in controlling the consistency of the fine aggregate during construction. The proposed fine aggregate grading requirement should be presented in the concrete materials DM. When manufactured sand is allowed in the project specifications, the optional requirement limiting the amount of material passing the 75- $\mu$ m (No. 200) sieve should be used if the Contractor chooses to use manufactured sand. See paragraph 2-3b(8) of this manual entitled "Fine Aggregate Grading Requirements."

*l. Coarse aggregate grading requirements.* Whenever the maximum aggregate size is less than 150 mm (6 in.), the inapplicable portion of the table on coarse aggregate gradings should be deleted in the project specifications. When coarse aggregate is to be supplied from commercial sources in an area where local practice provides size group separations other than those in the table, the table may be appropriately modified providing the local grading practice permits adequate control of grading. The revised grading should be presented for approval in the concrete materials DM. Rescreening and washing will be required for all mass-concrete structures.

*m. Batching and mixing plant.*

(1) Type of plant. The specifications provide for two alternates, an automatic batching plant or a semiautomatic batching plant. The selection of batch-plant type will be based on and supported by the concrete materials DM. The paragraph entitled "Equipment" provides the option of an onsite or offsite plant. The selected option will also be based on the concrete materials design memorandum. (Reference Chapter 3 herein.)

(2) Capacity. The paragraph in part 2 entitled "Capacity" of CW-03305, "Guide Specification for Mass Concrete," requires that a minimum capacity for batching, mixing, and placing system be inserted. The determination of the plant capacity is a part of the preparation of the concrete materials DM, and the capacity inserted in the



1 Feb 94

specification should be supported by the DM. Chapter 3 of this manual gives additional guidance.

(3) Preset mixtures. If an automatic batching system is required, it is necessary to indicate the number of present mixtures that may be produced by the plant. This number should be based on the anticipated construction sequence and the number of different mixtures to be used in the various features of the projects at approximately the same time. For example, on a large dam it is likely that exterior and interior mass concrete will be placed at the same time but in different locations. It is also possible that structural concrete may be required during the same shift as mass concrete is being placed elsewhere. The number selected should be realistic, not excessive simply to avoid the needed planning and analysis.

(4) Mixers. Any type of stationary mixer may be used for mixing concrete containing 75- or 150-mm (3- or 6-in.) nominal maximum size aggregate if it meets the capacity and the uniformity requirements. Concrete containing 50-mm (2-in.) and smaller maximum size aggregate may be mixed in stationary or truck mixers.

*n. Conveying and placing.*

(1) Conveyance methods. Optional paragraphs are provided to cover belt conveyors and pump placement, and these should be included in the project specifications, or not, depending on the project. The concrete materials DM should be referred to when preparing the specifications paragraphs related to methods of conveyance.

(2) Hot-weather mixing and placing. To reduce the problems of slump loss and plastic shrinkage cracking, limits are placed on the temperature of the concrete when placed. For guidance in selecting the correct placing temperatures, see Table 8-1 of this manual.

(3) Placing temperature. An optional paragraph of CW-03305 requires a special placing temperature in certain portions of the structure. The selection of an alternate and the completion of the blanks within the paragraph chosen shall be based on and supported by the concrete materials DM or a separate DM on Thermal Studies as outlined in Chapter 3 of this manual.

(4) Lift thickness. Lift thicknesses are to be shown on the drawing which shall show the required and optional construction joints. The maximum lift height for each portion of the structure will be determined by the thermal study and documented in the appropriate DM.

(5) Placing concrete in unformed curved sections. This optional paragraph will be included in all specifications for projects that include an ogee spillway crest and spillway bucket.

(6) Concrete deposited in water. This optional paragraph will be included in all specifications for projects that include underwater placement concrete. The decision to use underwater placement in lieu of conventional dewatering must be discussed in the concrete materials design memorandum as outlined in Chapter 2 of this document.

*o. Finishing.*

(1) Unformed surfaces. A steel-trowel finish may be specified for those areas requiring it by listing the areas in the paragraph entitled "Trowel Finish" of the guide specifications. Steel-trowel finishes are generally required in areas where cleaning is required such as generator decks, visitor facilities, and shop and office areas. If the floors are to be overlaid with tile, coatings, or coverings, the manufacturer's recommendations should be consulted when preparing the specifications to determine the finish requirements.

(2) Formed surfaces. The guide specification provides for four classes of finish for formed surfaces. The required class of finish must be denoted on the project plans. An AHV (Class A, high velocity) finish will be required on all surfaces exposed to water velocities of 40 ft/s or higher.

(3) Insulation and special protection. These paragraphs of CW-03305 contain blanks for cold-weather protection. The information inserted in these paragraphs will be based on and supported by the thermal study. It is also necessary to determine the age beyond which insulation will no longer be required. In areas where concrete placement is subject to a winter shutdown, it should be assumed that all mass concrete placed since the spring startup will be insulated throughout the following winter shutdown period unless results of the thermal study indicate otherwise.

*p. Areas to be painted.* If the project includes large areas of concrete surfaces that will be painted, they should be impervious-sheet cured, moist cured, or cured with a chlorinated-rubber base curing compound.

*q. Setting of base plates and bearing plates.* The paragraph with this title in CW-03305 with subparagraphs should be included in the project specifications if the project includes base plates or bearing plates. A gas-liberating

admixture should be used only when the area is essentially confined.

*r. Measurement and payment.* The paragraph entitled "Measurement and Payment," CW-03305, will be edited to reflect the outcome of the cementitious materials investigation outlined in Chapter 2 of this EM and documented in the concrete materials DM.

#### **5-5. Guide Specification "Formwork for Concrete," CW-03101**

*a. General.* The Guide Specification CW-03101, "Formwork for Concrete," will normally be included in any specification for a project which includes concrete in any amount. It is included as "related work specified elsewhere" in each of the three guide specifications for conventionally placed concrete, CW-03307, CW-03301, and CW-03305. Guidance for preparation of the project specifications is included in the following paragraphs.

*b. Shop drawings.* The number of days that drawings shall be submitted prior to fabrication should be based on consultation with construction division personnel in the district to determine a reasonable time.

*c. Sample panels.* Sample panels are required any time a Class A or a special architectural finish is required.

*d. Forms.* The areas on the project to receive each class of finish will be listed in the specification paragraph entitled "Materials" of CW-03101. This information must be taken from structural and architectural drawings.

*e. Form removal.* Forms will not be removed until a specified length of time has elapsed and a percentage of the concrete strength has been reached. The percentage figure to be inserted must be obtained from the structural designer.

#### **5-6. Guide Specification "Expansion, Contraction, and Construction Joints in Concrete," CW-03150**

*a. General.* This guide specification should be included in any project specification that includes joints in the concrete.

*b. Cost of testing.* Preparation of a project specification based on this guide specification requires that a division laboratory be contacted and costs obtained for testing field-molded sealants and nonmetallic waterstop. These costs are inserted in specification CW-03150.

#### **5-7. Guide Specification "Precast-Prestressed Concrete," CW-03425**

*a. General.* This Guide Specification CW-03425, "Precast-Prestressed Concrete," is for use on important structures which use precast-prestressed members; therefore, it is not intended to be edited except to select available options. Guidance for the section of the options is provided in the following paragraphs.

*b. Air content.* The decision of whether or not to require entrained air in precast members must be made based on a determination of the exposure conditions to which the members will be subjected both in service and in transit and storage. Generally, air entrainment should be required in any precast concrete placed in exposed locations where freezing of concrete saturated with water is likely to occur. When this decision is made, the optional paragraphs in the guide specification will be edited accordingly.

*c. Tolerances.* The optional tolerance paragraphs will be edited depending on the type of members being procured by including or excluding those paragraphs which apply to that type of member.

*d. Cement.* Guidance for selecting the various optional requirements is provided in paragraph 2-2 of this manual.

*e. Aggregates.* The option is provided if using aggregates meeting the requirements of ASTM C 33 (CRD-C 133) or if economically beneficial and technically acceptable, the specifications of a state or local agency may be used. This would be the case if, for example, the most likely source of precast members was heavily involved in producing units for a large highway department project and had produced large quantities of aggregate for that purpose. If the material was shown by case history or by testing to be adequate for the need, advantage should be taken of the availability and the resultant savings rather than forcing production of an aggregate meeting a different specification but offering no real advantage in concrete quality.

*f. Finishing.* Optional requirements are provided for the type of finish depending on architectural or service needs.

#### **5-8. Guide Specification "Preplaced-Aggregate Concrete," CW-03362**

Preplaced-aggregate concrete is produced by placing a gap-graded coarse aggregate in a form and later injecting a sand-cement-fly ash grout to fill the voids. Its main advantage is

**EM 1110-2-2000**  
**1 Feb 94**

its low volume change because of the high coarse aggregate content and the point-to-point contact of the coarse

aggregate particles. See paragraph 11-2 of this manual for more information.

## Chapter 6 Coordination Between Design and Field Activities

### 6-1. Bidability, Constructibility, and Operability Review

*a. General.* The requirements for bidability, constructibility, and operability (BCO) reviews are outlined in ER 415-1-11, "Bidability, Constructibility, and Operability." BCO reviews are to be performed first during the review period for the concrete materials DM and again at least 30 days before formal advertisement for bids of a construction contract. When concrete construction is involved, it is important to assure that qualified personnel from the area office or resident office are included in this review process.

*b. Review guidance.* Some of the areas that the personnel in the area or resident office provide important input for concrete construction to the designers are:

(1) Recommend location of aggregate production or handling facilities on or near the project site to avoid conflict with future project construction activities.

(2) Recommend location of batch plant on, or near, the project site for maximum efficiency and ease of concrete delivery and placement.

(3) Recommend types of placing equipment to be and not to be used.

(4) Present special forming and staging requirements.

(5) Recommend potential water sources.

(6) Recommend location of construction joints.

(7) Clarify bidding documents.

(8) Identify potential placement problem areas related to the structural shapes, size, and location of reinforcement, location of embedded items, conduits, blockouts, etc.

(9) Submit effects of proposed architectural requirements upon constructibility.

(10) Submit effects on the construction schedule of insulation requirements, concrete mixtures which develop strength slowly, or other unusual design requirements.

### 6-2. Engineering Considerations and Instructions for Construction Field Personnel

*a. General.* Subsequent to the award of any construction which involves concrete features, a report should be prepared by the designer outlining all special engineering considerations and design assumptions and providing instructions to aid the field personnel in the supervision and quality verification of the construction contract. The information provided will, for the most part, summarize the data contained in the DM's and include all required formal discussions on why specific aggregate sources, plant locations, structural designs, etc. were selected so that the construction personnel in the field will be provided the necessary insight and background needed to perform reviews of the Contractor's various submittal proposals and to resolve construction conflicts without compromising the intent of the design. This information must not conflict with the project specifications and must not contain any request to change these requirements. In all cases, the contract specification will govern.

*b. Content.* A typical outline for the concrete construction part of the report is provided as an aid in preparing the engineering considerations and instruction for construction field personnel:

#### I. Introduction

##### A. Purpose

##### B. Scope

#### II. Cementitious Materials Requirements or Properties

##### A. General

##### B. Availability

#### III. Aggregate Requirements or Properties

##### A. General

##### B. Basis for selection of listed requirements

##### C. Possible processing requirements

##### D. Quality assurance testing

#### IV. Other Materials

- A. Chemical admixtures
- B. Water
  - (1) Mixing
  - (2) Curing
- V. Concrete Qualities Required at Various Locations Within the Structures
- VI. Concrete Temperature-Control Requirements
- VII. Cold-Weather Concrete Requirements
  - A. Insulation
  - B. Time length of protection
- VIII. Hot-Weather Concrete Requirements
- IX. Contractor Quality Control and Government Quality Assurance
- X. Critical Concrete Placement Requirements
- XI. Architectural Requirements
- XII. Finish Requirements

c. Discussion by outline heading.

(1) Introduction. The purpose of the report will be stated here and will also contain a statement on the scope of the engineering considerations and instructions for construction field personnel. Types of concrete and the areas each type is to be placed are to be discussed.

(2) Cementitious materials requirements or properties. All those cementitious materials that have been included as options in the project should be discussed. If any type or types of cementitious material may not be used, the basis for the exclusion must be discussed to provide the construction personnel on the site the information required to correctly comment on the Contractor's submittals and proposed substitution of an unacceptable cementitious material. All quality assurance testing requirements should be discussed, including the required or desired frequency of onsite sampling.

(3) Aggregate requirements or properties. All the important characteristics of the selected aggregate sources

are to be summarized along with the basis for rejection of any nearby aggregate sources that were investigated and found to be unsuitable. Other helpful information to be included would be an assessment of potential processing requirements. Potential processing requirements that are to be discussed are requirements for spray bars and sand classifiers, requirements to make up a naturally deficient fine or coarse aggregate size, removal of elongated particles by a roll crusher should be noted if the processibility studies have revealed such. The range of aggregate quantity parameters derived from testing of the listed sources must be provided to the field so that the results of the quality assurance and quality control tests during construction can be compared to the assumed design values. It is especially important to note the qualities that are critical and those qualities that are marginal for acceptability of any source. A list of the quality assurance tests to be performed by the Government and the desired frequency of testing is to be included.

(4) Other materials.

(a) Chemical admixtures. The reasons for allowing or disallowing the use of retarding, accelerating, water-reducing, high-range water-reducing, or any other commonly used chemical admixture must be stated.

(b) Water. It must be noted if the concrete materials investigations have shown any problems with the available sources of mixing and curing water, such as a tendency to stain the concrete or seasonal variations that would be objectionable.

(5) Concrete qualities required at various locations within the structures. The most important objective of the report is to provide to the construction personnel in the field the quality (type) of concrete required for each structure or specific portion of a structure. Depending upon the nature of the construction project, this information could be presented in tabular form or by color coding the appropriate project drawings. The quality should be designated by maximum w/c, nominal maximum aggregate size, strength requirement, and purpose, such as interior mass, exterior mass, interior structural, exterior structural, backfill, architectural, etc. It should be noted that for isolated congested areas the nominal maximum aggregate size must be reduced. The basis for the quality requirements, i.e. strength, durability, appearance, etc., is to be stated for each one listed. The age at which the compressive strength,  $f'_c$ , is to be attained should be noted. Other mixture proportioning requirements which are to be listed are the nominal maximum size aggregate, air content, and the slump

range. It should be noted that the concrete should be sampled and tested for air, slump, and compressive strength during plant shakedown so that any necessary adjustments to the laboratory mixture proportions can be made before concrete is placed in the structure. It should also be noted that sampling for mixture proportioning should be observed by project office personnel to assure that quality and grading meet the specifications.

(6) Concrete temperature-control requirements. If temperature-control requirements are a part of the project specifications, they are to be explained in the report. To the maximum extent possible, this discussion should describe the effects of any changes in the proportioned mixtures upon the thermal control measures for the project as well as the results of any changes from the anticipated construction schedule. If more extensive temperature-control measures are specified, such as postcooling or postwarming, they are to be described in sufficient detail to allow for timely review of the Contractor's submittals for these systems. The most common methods of temperature control involve specified maximum or minimum placing temperature, followed by the use of insulation. Some possible methods that the Contractor may submit to achieve the specified placing temperatures are to be discussed along with any known methods that have been unsuccessful in the past.

(7) Cold-weather concrete requirements. Assumed methods of achieving the specified results during cold weather are to be discussed in this report. Any specified concretes in the project that require cold-weather protection in excess of that to ensure freedom from damage of early freezing is to be explained. The use of any specific accelerators, the keeping of temperature records, heating of materials, foundation preparation, protective insulating coverings, heated enclosures, curing, and form removal are to be discussed.

(8) Hot-weather concrete requirements. The assumed methods of achieving the specified results during periods of hot weather are to be discussed in this report.

(9) Contractor quality control and government quality assurance. Contractor quality control (CQC) requirements are specified in the specification. Government quality assurance (GQA) sampling and testing requirements should be discussed. These may include, but not be limited to, sampling and testing frequency, sampling size and procedures, testing methods, and analysis of test results for cementitious materials, aggregate grading, aggregate moisture, aggregate quality, slump, air content, concrete temperature, and compressive strength.

(10) Critical concrete placement requirements. All areas of the project that the designer feels require special measures during placement, consolidation, finishing, or curing are to be discussed in this report. Some examples are the placement of trunion girders, tunnel linings, bridge decks, and areas subjected to high-velocity flows of water.

(11) Architectural requirements. All areas where the specified architectural requirements will affect the concrete placement are to be discussed in this report. This will include all areas where the location of construction joints is mandatory for the desired aesthetic results or where exposed aggregate or form linings are required. The report should supplement the project specifications by providing information on possible techniques to achieve the desired surface textures and explaining the effects the architect wants in the facility.

(12) Finish requirements. The type of finish, as detailed on the drawing for each portion of the structure, is to be discussed.

## Chapter 7 Preparation for Construction

### 7-1. Materials Acceptance Testing

a. *General.* Depending on the nature of the project and the guide specification selected, acceptance of the concrete materials proposed for use on a project will be based on testing in a government laboratory, certified test results, or certificates of compliance submitted by the Contractor. An important responsibility of the resident engineer's staff is to assure that materials submitted for testing or that certificates of compliance represent the actual materials proposed for use.

b. *Cement, pozzolan, and GGBF slag.* The requirements for the acceptance testing of cement, pozzolan, and GGBF slag are stated in the various guide specifications for concrete. The policy and responsibilities for carrying out the cement, pozzolan, and GGBF slag acceptance testing function of the Corps of Engineers is set forth in ER 1110-1-2002, "Cement, Pozzolan, and Slag Acceptance Testing." The procedures for requesting cement, pozzolan, and GGBF slag testing and the procedures for sampling and testing are outlined in the ER. The USAEWES is responsible for the sampling, testing, and quality verification of cement, pozzolan, and GGBF slag at mill or source locations within the Continental United States (CONUS). Personnel at the district, area, or residency level are responsible for requesting cement, pozzolan, and GGBF slag acceptance testing, determining the amount of the charges, and providing the required funding document to WES. Residency personnel remain responsible for assuring that the cement, pozzolan, and GGBF slag reaching the project site are from sources that have been tested, have not been contaminated in transit, and are properly handled and stored at the project site. When cement or pozzolan is supplied from sealed bins, the members of the residency staff are responsible for sampling, shipping the samples to WES, and sealing the bins and transporting vehicles. For additional information contact CEWES-SC. When cement, pozzolan, and GGBF slag are being supplied from a prequalified source, project samples will be taken and funding to WES provided as outlined in ER 1110-1-2002. Project personnel should sample at the frequency required or may choose to sample more frequently if they suspect that the cement, pozzolan, or slag may be deviating from the specification requirements. There is no additional charge for testing project samples when these samples are taken to aid in assessing a problem with the material being delivered to the project. When cementitious materials are accepted by mill tests, this requirement should be strictly enforced, and a file of the mill test reports should be maintained. Silica fume

will be accepted by certified test reports from the manufacturer.

c. *Chemical admixtures.* The procedures for acceptance testing of chemical admixtures for concrete are outlined in ASTM C 260, ASTM C 494, and ASTM D 98 (CRD-C 13, 87, and 505, respectively). When acceptance testing is required by the project specifications, sampling will be performed by resident office personnel, and testing will be performed by a division laboratory. To reduce duplication of effort, results of completed tests of chemical admixtures should be routinely furnished to WES in accordance with ER 1110-1-8100, "Laboratory Investigations and Materials Testing."

(1) Test of air-entraining admixtures. The procedures for testing air-entraining admixtures are covered in ASTM C 233 (CRD-C 12), and the specifications for air-entraining admixtures are given in ASTM C 260 (CRD-C 13).

(a) Abbreviated tests. When it has been determined by review of previous data obtained from quality tests that a division laboratory has a sufficient background of information on a given air-entraining admixture to indicate that it is a product of good quality and acceptability as determined by the criteria set forth in ASTM C 260, subsequent samples may be evaluated by abbreviated tests. Abbreviated tests shall consist of performing all tests called for under regular tests except those for determination of compressive and flexural strength at 28 days, 6 months, and 1 year, and resistance to freezing and thawing. Tests to determine compliance with the time-of-setting requirements need not be performed unless specially requested.

(b) Initial uniformity tests. On the first sample of air-entraining admixture tested for a project and found to comply with the applicable requirements by either the quality tests of ASTM C 260 or by the abbreviated tests, initial uniformity tests will be conducted to provide criteria for evaluation of results of uniformity tests on samples representing subsequent lots. The uniformity tests will consist of pH, density, and air content of mortar as outlined in ASTM C 233.

(c) Uniformity tests of subsequent samples. Samples representing a subsequent lot of air-entraining admixture from the same source on the same project as a previous lot tested by quality or abbreviated tests and found to comply with the applicable requirements may be tested by the uniformity test methods outlined in ASTM C 233. The results of uniformity tests will be compared with the results of the initial uniformity tests, and if they agree, the air-entraining admixture may be considered to comply with the

specifications. Rejection of the air-entraining admixture should be based only on full or abbreviated test results.

(2) Test of other chemical admixtures. The specifications and procedures for testing and evaluating chemical admixtures are given in ASTM C 494 and ASTM C 1017 (CRD-C 87 and 88).

(a) Abbreviated tests. When it has been determined by review of previous data obtained from quality tests that a division laboratory has sufficient background of information on a given admixture to indicate that it is a product of good quality and complies with the specifications set forth in ASTM C 494, subsequent samples may be evaluated by abbreviated tests. Abbreviated tests of chemical admixtures shall consist of two rounds of tests for water content, initial time of setting, and compressive strengths at 3, 7, and 28 days.

(b) Initial uniformity tests. On the first sample of admixture tested for a project and complying with the applicable requirements by either the quality tests of ASTM C 494 or by the abbreviated test, initial uniformity tests will be made to provide criteria for evaluation of results of uniformity tests on samples representing subsequent lots. The uniformity tests will consist of density, residue by oven drying, and infrared spectroscopy.

(c) Uniformity test of subsequent samples. Samples representing a subsequent lot of admixture from the same source on the same project as a previous lot tested by quality or abbreviated tests and found to comply with the applicable requirements may be tested by the uniformity test methods outlined in ASTM C 494. The results of these uniformity tests will be compared with the results of the initial uniformity tests, and if they agree, the admixture may be considered to comply with the specifications. Rejection of the admixture should be based on full or abbreviated tests.

(3) Tests of accelerators. If calcium chloride is used on a project using the minor concrete guide specifications, it may be accepted based on recent certification that it complies with ASTM D 98 (CRD-C 505) or ASTM C 494, Type C or E.

*d. Aggregates - listed source.* When the Contractor proposes to furnish aggregates from a listed source, the resident engineer remains responsible for assuring that the aggregate being produced is of similar quality to that which was tested during the design process. Immediately after receipt of information on the Contractor's source of aggregates, samples should be taken from material produced

by the Contractor and forwarded to a division laboratory for a confirmation of quality. The amount of testing to be conducted will vary with each individual source. Testing program considerations will include length of time since testing was last performed, the amount of material removed from the source since testing was performed, and the variability of the deposit. The resident office should correlate testing requirements with the engineering division materials engineer. The Contractor on mass concrete projects using guide specification CW-03305 will have responsibility for quality testing before mixture proportioning samples are taken.

*e. Aggregates - nonlisted source.* When the Contractor proposes to furnish aggregates from a source not listed in the specifications, samples will be taken by the Contractor under the supervision of the resident office. The methods of sampling are outlined in CRD-C 100. The approval or disapproval of the proposed source should be handled as quickly as possible, and appropriate personnel from the division and district should make site visits as needed when a major project is involved. The evaluation of test results is primarily a responsibility of the engineering division of the district or division office. The source will be accepted only if the quality meets the required test limits. The aggregate samples will be tested and evaluated in accordance with the guidance provided in Chapter 2 of this manual. All testing will be accomplished in the appropriate division laboratory.

*f. Aggregates - minor concrete jobs.* Minor concrete job specifications will require the aggregate to meet ASTM C 33 (CRD-C 133) or a state highway specification. If the concrete supplier's source of aggregate is from a local source which has been used for some time, then a service record will have been established and only minimum testing is necessary. The resident engineer or project engineer, however, has the responsibility to ascertain that the aggregates meet the required quality, and if there is any question, such as a newly opened source, quality testing should be performed in the division laboratory.

## 7-2. Mixture Proportioning

*a.* For concrete projects using Guide Specification CW-03305, mixture proportioning is the responsibility of the Government. Before the concrete placing starts, the mixture proportioning study should be completed using materials proposed by the Contractor. Chapter 4 of this manual discusses in detail the procedures for sampling of concrete materials for mixture proportioning and for proportioning to meet project requirements. The mixture proportioning criteria are to be provided to project personnel as outlined



in Chapter 6. The importance of submitting samples which meet quality and grading requirements and which are representative of materials to be supplied to the project cannot be overstated. Due to the variation of materials supplied during construction, mixture proportions may need to be adjusted. Adjustment of laboratory mixture proportions should be done during plant shakedown.

b. For projects using Guide Specification CW-03301, the mixture proportioning is the responsibility of the Contractor. Before the concrete placing starts, the Contractor should submit the mixture proportions and all the test reports for review.

c. For structures using Guide Specification CW-03307, the concrete will most likely be supplied by local ready-mixed plants. The Contractor's mixture proportions should be submitted to the resident office and should be checked for appropriateness and completeness before start of concrete production.

### 7-3. Concrete Plant and Materials

a. *Review of concrete plant drawings.* The contract specifications may require the Contractor to submit drawings showing the layout and material handling details of the proposed concrete plant to the Contracting Officer for review. It is the Contractor's responsibility to provide and maintain a dependable concrete plant of the required capacity. Review comments should be limited to (1) if the plant meets the requirements of the contract specifications or (2) a list of specific deficiencies if the plant does not meet the specified requirements and (3) any other comments on specific plant features or details that are questionable or appear deficient.

b. *Estimating plant capacity.* The capacity of a concrete plant is commonly determined by the number of mixers, the rated capacity of each mixer, along with the charging, mixing, and discharging time of each mixer. The total time required should be increased by 15 sec/batch when the capacity for sustained operation is computed. Thus, a concrete plant that contains two 4-yd<sup>3</sup> tilting drum mixers, each of which can be charged in 20 sec and discharged in 15 sec, would have the following computed capacity: A "rule of thumb" mixing time for a 4-yd<sup>3</sup>, one-opening, tilting-type mixer is 1 min, 45 sec. Therefore, the total time per 4-yd<sup>3</sup> batch for such a mixer is:

20 sec	-	charging mixer
1 min, 45 sec	-	mixing
15 sec	-	discharging
15 sec	-	other
<hr/>		
2 min, 35 sec	-	Total

Thus, the concrete plant capacity is 8 yd<sup>3</sup> in 2 min, 35 sec or approximately 185 yd<sup>3</sup>/hr. If the number of mixers is insufficient when judged by the mixing time calculation, which may be the case if the Contractor proposes to use turbine mixers or very large tilting mixers, the plant should be designed so that the extra mixers can be added. Any comments on the concrete plant should point out that the extra mixer(s) will be required if the mixing time proposed by the Contractor does not satisfy the uniformity requirements. Normally, batching time is not critical. However, in a plant equipped with a vertical shaft (turbine) mixer, in which cumulative weighing is employed, the batching cycle should be compared to the mixing cycle to determine which is critical. It is always necessary to make a careful check of the capacity of the material conveying systems into the concrete plant and the concrete transportation system from the concrete plant to the placement site. When placing concrete in the area of the structure that is the most remote from the concrete plant, the concrete transportation system should be capable of handling the entire output of the plant with allowances made for any time required to reposition the discharge equipment and minor delays by the placing crew.

c. *Aggregate storage, reclaiming, washing, and rescreening.* Most project specifications for any size project will require that sufficient aggregate be on the site to permit the continuous placement and completion of any lift started. The contractor's proposed plant for the storage and delivery to and from storage should be checked to determine if they are of sufficient capacity to be able to easily comply with the production capacity requirements. The capacity of the storage bins should be checked against the preliminary mixture proportions to assure adequate size for all mixes. If the fine aggregate is wet when it is stockpiled and there are no mechanical dewatering devices provided, there must be sufficient storage capacity to allow the fine aggregate to drain freely to obtain a uniform and stable moisture content before being deposited in the batch plant bin. Aggregate reclaiming facilities, washing, and rescreening facilities (when required) should be carefully examined to determine that they are of sufficient capacity to maintain all of the bins over the batchers at least half full when the plant is producing concrete at the rated maximum capacity of the plant.

*d. Concrete cooling plant capacity.* There are two principal requirements of an aggregate cooling system: (1) there must be sufficient refrigeration capacity, and (2) the aggregate must be in contact with cooling system long enough to permit the transfer of sufficient heat between the aggregate and the medium. The refrigeration capacity must be that required for the maximum placing rate during the hottest summer months with an assumed loss of at least 10 percent between cooling and mixing. The length of time required for the heat transfer will depend upon the aggregate size. For example, if 150-mm (6-in.) aggregate is exposed to ice water for 20 min, less than 85 percent of the potential cooling will be accomplished regardless of the size of the refrigeration plant. The aggregate handling facilities should be planned so that heat gain is minimized after cooling. Modern ice-making equipment that can handle ice efficiently is available so that, for saturated aggregates, all the added water can be in the form of ice. It is important that all ice melts prior to the conclusion of mixing. Liquid nitrogen is also extensively used for cooling concrete, especially when the nitrogen manufacturing facilities are within the geographic area. Liquid nitrogen can be sprayed directly into the mixer with no ill effect. The nitrogen must be added while the mixer is turning. ACI 207.4R and the PCA "Design and Control of Concrete Mixtures" (Kosmatka and Panarese 1988) are excellent references for more detailed study.

#### 7-4. Batching and Mixing Equipment

*a. Checking compliance with specification requirements.* Prior to the beginning of concreting operations, the plant should be checked for compliance with the specification requirements. During the erection of the plant and installation of the equipment on large jobs, the inspection staff should become thoroughly familiar with the plant and its operating features. Plant drawings submitted by the Contractor for review by the Contracting Officer should be used in making the check and in becoming familiar with the plant.

*b. Scale checks.* All scales should be checked by standard weights before being placed in operation. During plant shakedown and the beginning of concrete production for onsite plants, the operation of the scales should be observed closely. If any trouble is apparent, it should be corrected immediately. Subsequently, the accuracy of the scales should be checked once a month. Checking of scales is a responsibility of the Contractor under the quality control provisions, but the government inspection force has the responsibility for verification. This verification should be accomplished by observation of the scale checks performed

by the Contractor and actually checking scales when an accuracy disagreement occurs.

*c. Mixer blades and paddles.* Mixer blades should be examined before concrete production begins and must be monitored during construction. If there is a buildup of hardened concrete in the drum or if the blades become badly worn, previously obtained uniformity test data are no longer applicable. Thus, when the blade shows 10-percent wear, the blades should be replaced and additional uniformity tests run. Several methods have been used to monitor blade wear to determine when the blade has worn 10 percent. One method is making a plywood template of portions of the blades. Another is drilling small holes in the blade where "10-percent wear" would be. Another is simple blade measurements. Measurements or holes must be located and recorded so that they can be relocated. Selection of method and monitoring must begin at the time the uniformity test is performed. Pug mill paddles should be checked in a similar manner.

*d. Recorders.* The agreement between recorder reading and dial indications should be checked regularly. This can be done easily whenever scales are calibrated, although it may be done any time the scales are in operation. The pens on pen recorders should be examined frequently to ensure that they are not clogged, that they have a supply of ink, and that they do not produce too wide a line. It is a source of convenience to write on the chart the location at which concrete is being placed at any time.

*e. Batching sequence.* When aggregates are batched cumulatively, the last material batched has its mass recorded with the least accuracy since the tolerances in project specifications apply to the total mass in the hopper rather than to the mass of the individual fraction. If possible, fine aggregate should not be batched first or last. It should be batched second, following the coarse aggregate fraction having the smallest mass. Batching sequence can have a profound effect on mixing time for most mixers. If a charging conveyor is used, then ribboning materials together on the belt as much as possible can result in more efficient mixing and shorter mixing time. Liquid admixtures should be batched with the water or damp sand. Each chemical admixture should be batched separately and should be batched at the same point in the charging cycle for every batch.

*f. Mixer performance and mixing time.* The mixing time at the start of a job using onsite plant mixers should be determined prior to the start of concrete production. On jobs covered by Guide Specification CW-03305, mixer

performance tests will be conducted by the Contractor as required by the specifications. The mixer performance tests for plant mixers are performed in accordance with CRD-C 55 at the specified intervals. The mixer performance tests for plant mixers using continuous mixers are to be performed in accordance with CRD-C 55 with the spacing of the sampling intervals modified as appropriate for the continuous operation. Allowable variation will be the same as for batch mixers. When truck mixers are in use on any size job, their performance will be determined at the specified intervals in accordance with ASTM C 94 (CRD-C 31) and shall meet the variation tolerance specified therein. When mobile volumetric batching and continuous mixing plants are used for minor structures, mixer performance tests shall be performed in accordance with and shall meet the variation tolerance specified in ASTM C 685 (CRD-C 98). When plant mixers are used, tests at reduced mixing times will be made by the Government any time reduced mixing times are proposed by the Contractor. Tests may be conducted by the Government at the initial startup of the plant for mass-concrete jobs if desired.

## 7-5. Conveying Concrete

*a. General.* Transportation of concrete from the mixer to the forms should be done as rapidly as possible so that the properties of the concrete as discharged from the mixer are not changed materially. The devices used for receiving the concrete from the mixers and conveying it to and depositing it in the forms should be designed to maintain the concrete in the same condition in which it is discharged from the mixer. ACI 304R provides an easily obtainable source of information on transporting concrete. The contractor's conveying system should be reviewed and appropriate comments provided.

*b. Buckets.* When concrete is transported from mixer to forms in bottom-dump buckets, controllable discharge buckets are required. The specifications limit the size of the pile in which concrete may be deposited to 4 yd<sup>3</sup>. However, buckets with a capacity greater than 4 yd<sup>3</sup> may be used if they have multiple discharge gates or other controls so that more than one pile is deposited on discharge, none of which exceeds 4 yd<sup>3</sup>.

*c. Truck mixers and agitators.* Truck mixers will not adequately mix concrete made with aggregate having a maximum nominal maximum size greater than 37.5 mm (1-1/2 in.) and should not be used for mixing or transporting and agitating such concrete or concrete with 2-in. slump or less. In general, whenever truck mixers are permitted for mixing concrete, agitators may be used for hauling concrete in the event the contractor elects to use centrally mixed

concrete, except that agitators will not be used when it is necessary to delay mixing of the batched material until the truck has arrived at the construction site. This requirement may occur when the batching, conveying, mixing, and placing operations would require more time than allowed by the specifications or when the rate of placement is so slow or intermittent that mixing cannot be properly scheduled at the central mixing plant. In such situations, a procedure of batching all the materials except cement, and not more than 80 percent of the water at the batch plant, and transporting to the construction site where the cement and remaining water is batched and the concrete mixed, should be used.

*d. Nonagitating equipment.* Truck-mounted nonagitating equipment specifically designed for hauling concrete may be used for a haul requiring less than 15 min over a smooth road. Standard dump trucks should never be used to haul conventional concrete.

*e. Positive-displacement pump.* The transportation of concrete through pipelines by positive-displacement pumps is an acceptable method for transporting concrete of medium consistency. This method is especially useful for tunnel linings and other areas with insufficient room for handling buckets. Pumps may be authorized whenever the aggregate size, slump, and length of line are within the manufacturer's recommendations for the apparatus proposed and the desired quality of concrete can be obtained. A positive-displacement pump is a piston pump or a squeeze pressure pump. A pneumatic pump is not a positive-displacement pump. The use of aluminum for concrete pump pipe is not permitted. The use of aluminum pipe is potentially dangerous and could result in substantial reduction in the strength of the concrete. Refer to ACI 304.2R for more information on placing concrete by pumping methods.

*f. Belts.* Slow conveyor belts are unacceptable as standard practice for transporting concrete. This method tends to produce segregation as the concrete travels on a slow belt. Any belt traveling at less than 300 ft/min is considered slow. When making the decision on whether or not to permit the use of conveyor belts to transport concrete, residency or area personnel should refer to ACI 304.4R which includes information on parameters and specifications for belt placement. Regardless of the outcome of the analysis of the contractor's proposal, the use of a belt conveyor should be discontinued if excessive segregation results.

*g. Chutes.* Chutes which are supplied by the ready-mixed truck manufacturer as a normal part of the ready-mixed trucks are usually satisfactory. Most other chutes tend to segregate the concrete as it is discharged and should not be approved.

1 Feb 94

## 7-6. Preparation for Placing

*a. General.* Placing of concrete should not be permitted until preparations have been completed. Preparation for placing includes form construction, cleanup of surfaces, assembling of placing and protection equipment, and other operations essential to proper concreting operations.

*b. Earth foundations.* Earth foundations should be properly compacted and should be clean and damp prior to placing the concrete.

*c. Rock foundations.* Rock foundations should be thoroughly cleaned and given any other necessary treatment required to ensure proper bond of the concrete to the rock. Roughening by "bush hammering" or by sandblasting may be necessary on certain types of rock; however, the removal of all loose coatings, scale, drummy rock, dried grout, and other similar materials usually provides a surface of required roughness.

*d. Cleanup of concrete surfaces.* Construction joints in concrete to which other concrete is to be bonded must be thoroughly cleaned to remove laitance and other harmful coating. When properly prepared, the surface of the concrete will present only clean coarse aggregate surfaces and sound mortar. Roughness is not necessarily a requirement. Cleanup of construction joints is usually accomplished by either one of three methods or by the use of a combination of these methods. These are the air-water cutting (green-cut), high-pressure water jet, and sandblasting methods. Some job specifications contain an optional provision, which if invoked, makes it possible for the Contractor to use a surface-applied retarder to extend the period of time during which air-water cutting is effective. When the Contractor elects to use a surface retarder, he is required to submit a sample for approval and to demonstrate the method of application. The surface retarder should meet the requirements of CRD-C 94. The principal requirement to be met by the application procedure is that it supply a uniform coat in all kinds of weather. Without retardation, the use of the air-water method requires particular care if satisfactory results are to be obtained. The time at which the air-water cutting should be accomplished is critical and is materially influenced by prevailing temperature conditions. When properly timed, the surface can be cleaned so that laitance resulting from bleeding is removed. Frequently, the proper timing of the operations on the entire surface of a lift in a large dam is not achieved and this probability should be considered before the method is approved. Cutting too early by the air-water or high-pressure water jet method results in damage to the surface

by undercutting the large aggregate and in the removal and wasting of otherwise suitable concrete. Cutting too late results in failure to clean the surface properly and necessitates wet sandblasting. A pressure of 3,000 psi appears to be adequate for cleaning concrete by the high-pressure water jet for concrete with strength of 3,000 psi. Higher strength concrete may require a pressure up to as much as 6,000 psi. Trials should be conducted on project concrete to establish the correct pressure. Cleaning by the sandblast method is accomplished after the surface has hardened and should be delayed as long as practicable, preferably until just prior to placing the next lift. The Contractor will be required to provide means for handling the disposal of the joint cleanup waste so that exposed surfaces will not be stained or otherwise damaged. Light sandblasting to remove surface stains resulting from faulty cleanup operations or the use of unsuitable curing water is permissible, but it will not be necessary if the cleanup operations are properly executed. The best bond between lifts is obtained when the surface of the old concrete is neither bone dry nor saturated but has been saturated and is in a drying condition.

*e. Placing equipment.* The requirements for placing equipment vary widely from job to job, depending on the plant used and placing conditions. The necessary facilities should be reviewed in advance and provided ready for use. In reviewing, attention should be given to the following specific items.

(1) Vibrators. Vibrators should comply with specification requirements. A sufficient number of vibrators should be at the job site to permit placing. Also there should be a reasonable number of spare vibrators available.

(2) Cold-weather and hot-weather protection equipment. Devices and methods proposed by the Contractor must meet the specifications requirements for cold-weather and hot-weather concreting. The equipment should be examined for adequacy and applicability well in advance of winter concreting so that any deficiencies may be corrected by the Contractor. Refer to ACI 305R and ACI 306R for more information on hot-weather and cold-weather concreting.

(3) Communication equipment. The Contractor should provide equipment for his use between the forms and mixing plant. The need for other equipment such as signaling and identifying devices depends on the complexity of the project and the number of different concrete mixtures employed. The resident engineer should require the Contractor to present for review plans or descriptions of the equipment well in advance of the start of concrete

placement. The GQA representative should be provided with separate communication equipment between the forms and mixing plant on large jobs where the mixture proportions are provided by the Government.

(4) Other equipment. The need for additional equipment depends on job requirements. Such equipment includes wire brooms for spreading grout, water removal equipment, elephant trunks, etc.

*f. Forms.* The type of forms to be used by the Contractor will be submitted for approval prior to construction. The submittal should be checked for compliance with the specifications.

*g. Curing and protection.* The methods and equipment proposed by the Contractor for the curing and protection of concrete should be reviewed to assure that they are capable of curing the concrete and protecting it in compliance with the specifications. Follow-up inspections should assure that the approved materials and equipment for curing and protection are available at the project site prior to the beginning of concrete placement.

*h. Approval.* Concrete placing should never begin until approval to do so by the Government has been given. A form checkout record should be used for larger and more

complex projects. The record should include form line and grade, grout tightness of the form, proper size numbers and position of reinforcement, waterstops, mechanical or electrical lines, cleanup of foundation or previous lift, proper transportation, placing and vibrating equipment, and curing and protection equipment. Both the government quality verifier and the Contractor's foreman should sign or initial the record. Figure 7-1 is a sample of a form checkout record.

*i. Interim slabs on grade.* Unless there is some other overriding reason, interior slabs on grade should be underlain by a capillary water barrier consisting of 4 to 6 in. of open-graded granular material, preferably crushed rock. While some engineers consider a vapor barrier unnecessary, it is usually good practice to install a vapor barrier below the concrete slab and above the capillary water barriers. This consists of a continuous plastic sheet, 6 mil or more thick. In some parts of the country, particularly the Southwest, it is customary to cover the vapor barrier with 2 in. of sand because of the concern that, without the separator, warping of the slab would be intensified. While in other parts of the country the vapor barrier is customarily placed directly beneath the concrete slab without a sand separator, it would be conservative practice to use the sand separator unless previous experience shows no need for it.

<b>FORM CHECKOUT</b>						
I T E M	INSPECTED BY			APPROVED BY		
	CONTRACTOR			CORPS OF ENGINEERS		
	NAME	DATE	TIME	NAME	DATE	TIME
GEOLOGY FOUNDATION						
DRAINAGE						
CROSS SECTION						
FORMS						
LINE & GRADE CONTROL CONCRETE PLACING						
REINFORCING						
PIPING						
WATER STOP						
ANCHOR BOLTS						
MISC. MECHANICAL						
ELECTRICAL						
CLEANUP						
SAFETY REQUIREMENTS						
WEATHER PROTECTION						
VIBRATING EQUIPMENT						
CURING MATERIALS						
<b>FINAL CLEARANCE</b>						
CONTRACTOR REPRS:				C.O.E. REPRS:		
<b><u>INSTRUCTIONS</u></b>						
<p>CONCRETE PLACING SHALL NOT BEGIN UNTIL EVERY ITEM IS CHECKED AND THE FINAL CLEARANCE IS SIGNED.</p> <p>IF ANY ITEM IS NOT APPLICABLE, IT SHALL BE NOTED "NA" AND SIGNED.</p> <p>BEFORE APPROVING THE "SAFETY REQUIREMENTS" ITEM, A FINAL INSPECTION SHALL BE MADE OF ALL WORKING FACILITIES FOR CONCRETE PLACING SUCH AS SCAFFOLDS, LADDERS, PLATFORMS, ACCESS WAYS, ETC., TO ASSURE THAT THEY ARE ADEQUATE, SAFELY CONSTRUCTED, AND IN READINESS.</p> <p>FINAL CLEARANCE SUBJECT TO REVOCATION IF SUBSEQUENT INSPECTION REVEALS ANY DEFICIENCIES.</p> <p>IF SUMMONED BY THE CONTRACTOR TO CHECK AN ITEM AND IT IS FOUND TO BE UNSATISFACTORY, STATE IN THE "REMARKS" COLUMN THE TIME SUMMONED AND THE TIME REJECTED.</p>						

Figure 7-1. Example of form checkout record

## Chapter 8 Concrete Construction

### 8-1. Forms

*a. Types of materials.* The contract specifications specify the types of finish required for the various formed surfaces and the types of materials permitted for each class of finish. If more than one type of material is permitted with each class of finish specified, the Contractor should always be permitted to employ his choice of materials.

*b. Quality verification.* After concrete forms have been set to line and grade and prior to permitting any concrete to be placed therein, the forms should be carefully inspected for compliance with all specification requirements, including sheathing materials, alignment of form surfaces, mortar tightness, and apparent strength.

*c. Form coating.* Most of the form coatings commercially available are satisfactory for wood forms. Quite frequently, form coatings which are satisfactory for wood forms do not perform satisfactorily on steel forms. If the form coating being used on the work is unsatisfactory, its use should be immediately discontinued and the Contractor should be required to obtain a suitable form coating.

### 8-2. Placing

*a. General.* The practices followed in the placement of concrete should have the principal objectives of concrete that is bonded to the foundation or to the previous lift, uniform in quality, free from any objectionable segregation, and thoroughly consolidated. These objectives are best accomplished by adequately cleaning and preparing the top surface of the foundation or the previously completed lift, delivering the freshly mixed concrete to its approximate final position in the structure with a minimum of segregation, and consolidating the concrete by means of sufficient vibration to consolidate it completely. In addition to these very general practices, the more detailed practices outlined below should be followed.

*b. Bedding mortar on rock foundations.* All rock foundations should be covered with a layer of mortar just prior to concrete placement. The mortar should be composed of the same fine aggregate and cementitious material used in the exposed concrete mixture. The sand/cementitious material and w/c of the mortar should also be the same as that used in the exterior concrete mixture proportions. Addition of an air-entraining admixture is not required. The thickness of the mortar layer should be

approximately 1/4 in. The delivery and spreading of the mortar should be scheduled so that all mortar is covered by the concrete before the initial set of the mortar.

*c. Mass concrete.* The general nature of mass concrete, having a stiff and dry consistency and containing 75- and 150-mm (3- and 6-in.) maximum size aggregates, is such that the concrete must be deposited in the final position in the structure in which it is to remain when compacted. The quantity of interior mass concrete that can be properly compacted in one operation is recognized to be about 4 yd<sup>3</sup>. The project specifications will usually limit the amount to be deposited in one pile for compaction to 4 yd<sup>3</sup> in uncongested areas and to smaller quantities in congested areas. Depositing 8 yd<sup>3</sup> in two contiguous piles from a two-compartment (4-yd<sup>3</sup> each) bucket is recognized to be in compliance with this requirement. Whenever the top of a lift is not horizontal, the placement must proceed up the slope. The thickness of the exterior concrete in a mass concrete structure is governed by the size of the bucket or the delivery equipment used in placing the concrete. Since the project specifications will limit the amount of concrete that may be deposited in one pile to 4 yd<sup>3</sup>, the exterior concrete will usually average about 5 to 6 ft thick. The placing procedure to be followed includes practices designed to keep the thickness of the exterior mixture to a practical minimum. Usually, a 7-1/2-ft lift of mass concrete is placed in five layers, and a 5-ft lift of mass concrete is placed in three layers as shown in Figures 3-1 and 3-2 of this manual. For example, in dam construction, if both interior and exterior mass concrete are used, the placement should begin with the first layer of interior mass concrete at the upstream end of the placement, leaving a space of the minimum practical, or specified, width between the interior mass concrete and the form for the placement of the exterior mixture concrete. The exterior mass concrete layer should be placed after the corresponding interior concrete layer has been placed, so as to keep the thickness of the exterior concrete to a practical minimum, or that specified. The intersection of the interior and exterior concretes should be carefully consolidated and "knit" together during vibration. The placement should then proceed toward the downstream face with the bottom layer preceding the second layer by an approximate distance equivalent to 4 yd<sup>3</sup> of concrete compacted. Each successive layer above should follow the layer below by approximately the same distance, thus providing a stepped placing procedure. The placement should follow a regular sequence for the successive layers by maintaining the stepped relationship of the layers until the lift is completed. Dumping of concrete on slopes and chasing it downhill with vibrators is not to be permitted under any circumstances. The transporting of concrete by vibration is not permitted.

*d. Structural concrete.* Proper care must be taken to avoid segregation when placing concrete into structural units such as walls, columns, slabs, beams, etc. The concrete is to be deposited in approximately its final position in the structure where it is to remain and should not be moved within the forms with vibrators. As a general rule, when the concrete bucket cannot be lowered to within 5 ft of the position where the concrete is to be placed, elephant trunks with a rigid drop chute bottom section are to be used. All belt conveyors must have elephant trunks at their discharge ends. The thickness of the layers should not exceed 20 in. The vibrators should be handled carefully so that thorough consolidation is achieved without damaging the forms or displacing embedded items. The vibrator should not be operated while being held against the form which results in sandy streaks or markings in the finished surface.

*e. Tunnel linings.*

(1) Inverts. The concrete for tunnel inverts may be delivered to the placement site by any practical means. It should be brought to grade in layers not to exceed approximately 1-1/2 ft and thoroughly consolidated with vibrators.

(2) Sidewalls and crown. Use of a positive displacement pump is the normal method of placing the concrete in tunnel linings. In the tunnel sidewalls, the concrete should be placed in successive layers of approximately 1-1/2 ft deep and thoroughly consolidated by vibration. In the crown of the tunnel where vibration is impossible, a length of the special pipeline used in the concrete pumping operation is kept buried in the fresh concrete. This is necessary to achieve consolidation of the concrete and to force the concrete into the overbreaks in the rock. Placement of the concrete in the crown must begin at the end of the form that is opposite the concrete pump, and the embedded pipeline will be backed out as the crown is filled. Short sections of vertical riser pipes have been used satisfactorily, in lieu of the buried pipeline, to place concrete in the tunnel crown. Pumping concrete is discussed in paragraph 10-6 of this manual and in ACI 304.2R.

*f. Consolidation.* Concrete that is placed in the dry with conventional methods should be consolidated by means of mechanical vibration equipment. The performance of the vibrators used by the Contractor should be periodically checked for compliance with the performance characteristics required by the contract specifications. Vibrators should never be used to transport the fresh concrete within the forms. The duration of vibration at a single point in the fresh concrete being consolidated should be approximately 10 to 15 sec or until the entrapped air is released, which is

indicated when large air bubbles stop coming to the top of the mixture near the insertion point of the vibrator. It is essential that the points of vibration be fairly closely spaced to obtain thorough and complete consolidation of fresh concrete. Proper care must be exercised to thoroughly vibrate the concrete in all forms, including flowing concrete, to minimize rock pockets, honeycomb, and other defects. It is almost impossible to over vibrate a properly proportioned concrete mixture. Emphasis should be placed on having closely spaced applications of appropriate duration rather than prolonged vibration at widely spaced distances. The latter method will result in inadequate consolidation in some parts of the concrete, which will result in an overall general reduction in the quality of the hardened concrete. In general, the use of internal vibrators for consolidation of freshly mixed concrete has been satisfactory. A thorough discussion of consolidation is given in ACI 309R.

*g. Protection of waterstops.* There are many cases of leakage through a joint because of faulty installation of the waterstop. To eliminate such failures, particular care must be exercised to ensure that waterstops are properly protected and installed. Adequate provisions must be made to support and protect all waterstops against damage during the progress of the work. Extraordinary care must be employed in the placement and consolidation of the concrete adjacent to the waterstops to ensure that the waterstops are not damaged and that they are in the correct position and properly embedded in the concrete.

### 8-3. Finishing

*a. Formed surfaces.* The finishing of concrete structures consists of dressing up the formed surfaces by patching the form bolt holes and removing any defective concrete and replacing it with sound durable concrete. This latter operation can be largely avoided by paying particular and vigilant attention to the details of the concrete placement operations, especially the consolidation, so that defective concrete will not occur. When such conditions do occur on exposed surfaces, the defective concrete must be chipped back to sound concrete and replaced by dry packing or a conventional concrete placement. In the removal of the defective concrete, care should be taken to prevent damaging the adjacent concrete while creating a dovetail or key into the hardened concrete to firmly anchor the new repair concrete. All defective concrete on the surface of a structure that is permanently exposed to view should be repaired. Additional guidance on repair materials and methods may be found in EM 1110-2-2002, "Evaluation and Repair of Concrete Structures." Honeycomb and rock pockets on bulkhead faces usually do not need to be



repaired unless they are of considerable extent or depth. Extra care must be taken to assure that the color and texture of the repair concrete closely matches that of the surrounding concrete. The guide specifications are clear and detailed in their requirements for all formed surfaces. The key to quality is the strict enforcement of the specification requirements. Class A finish is the best finish with the most strict requirements, while Class D is the least restrictive. Class AHV is a special finish for spillways, tunnels, or other water passages where the velocity of the water is expected to be 40 ft/s or higher. The materials and workmanship for forming of Class AHV are the same as the Class A finish requirements in Guide Specification CW-03101, "Formwork for Concrete," except that steel forms may be used. The allowance for offsets for Class AHV is more restrictive.

*b. Unformed surfaces.* The finishing of unformed surfaces is a very critical operation and requires the use of judgment, experience, and skill to produce a finished surface of the specified quality and durability. Cracking, scaling, and other defects are usually directly attributable to the use of concrete which is too wet (too high a slump), improper finishing procedures, or a combination of both. Overworking the surface is probably the most common cause of defective surface finishes. The fresh concrete should be thoroughly consolidated. The surface of the consolidated concrete should be slightly above grade. Screeding, or strikeoff, should be done immediately after consolidation. The screeding operation, when accomplished by hand methods, is to be accomplished with a sawing motion of the screed in the transverse direction to the line of travel of the screed. This will accomplish the dual purpose of screeding and compacting the surface at the same time. Any excess concrete that is left above grade should be carried ahead of the screed. In a properly proportioned air-entrained concrete, a characteristic roll of fresh concrete will form in front of the screed. In air-entrained concrete which has been properly consolidated, a slight rebound of the fresh concrete will occur behind the screed. Screeding should be limited to two passes of the screed. After the second pass of the screed, the rebound will be diminished to a negligible amount. Floating or darbying should be completed immediately after screeding and should be limited to that necessary to fill in low spots. The use of a jitterbug or tamper to embed the coarse aggregate particles should not be allowed. Floating and troweling should not be permitted on any part of the surface where any bleed water has collected. This bleed water must either be allowed to evaporate or be removed in a satisfactory manner. Dry cement, or a mixture of cement and fine sand, should never be applied directly to a surface to be finished for the removal of bleed water or for any other purpose. Adding water to the surface by use of a large brush, or other means,

should also be prohibited. The use of power rotary troweling machines needs to be carefully controlled to prevent overfinishing and the resultant crazing.

(1) Ogee crest. One of the most difficult finishing jobs on unformed surfaces is the ogee crest of a spillway. The following procedure is the most satisfactory one developed to date. The spillway piers and the high-strength erosion-resistant concrete in the spillway surface are placed monolithically with the spillway except for the top lift, which includes the ogee crest. Adjustable vertical rigid supports, conforming to the ogee shape are installed in the placement, raising the depth of the screed above the finished grade and bridging the placement surface. Concrete is placed and consolidated in the usual manner and then screeded and finished using the pipe as an elevation guide. When these operations are properly executed, a durable surface is produced.

(2) Spillway aprons. No general rules can be given for finishing of spillway aprons or stilling basin slabs. Since the shapes required to meet the hydraulic requirements differ for different projects, it is usually necessary to develop special methods for each situation. The finishing is frequently done by hand, although properly designed heavy-duty mechanical screeding equipment is acceptable. The method described above for ogee crests is suitable, with appropriate modifications, to the finishing of stilling basins, the curved transition surfaces at the toe of a dam, or for flip bucket spillways.

(3) Trapezoidal channel lining. The methods to be used on bottom slabs are the same as for any flat or nearly flat slab. The concrete should be placed and consolidated in the usual manner and left slightly above grade. The slab should then be struck off to grade by screeding and given a float finish. Finishing the sideslope paving in small channels will usually be accomplished by hand methods. Placing of the concrete will proceed upslope. The concrete should be of medium to dry consistency. The use of a mechanical screeding machine is considered advisable. Hand-manipulated screeds which are moved by mechanical means can also be used. Screeding should always proceed upslope. After screeding, the surface should be given a float finish.

(4) Surfaces exposed to high-velocity flow of water. Surfaces to be exposed to waterflow velocities greater than 40 ft/s should be finished carefully (AHV finish) since any discontinuity especially a positive offset in downstream direction in the surface can be the cause of cavitation. Cavitation has the potential of seriously eroding concrete

1 Feb 94

surfaces so the finishing of areas subject to cavitation damage should be carefully inspected.

(5) Floors.

(a) Monolithic. Where monolithic floors are specified, the completion of the floors should be delayed, if possible, until all other construction work from which damage to the floor might occur is completed. If this is impracticable, the floor should be adequately protected from damage.

(b) Bonded topping. In areas where structural slabs must be completed for the work to be accomplished, bonded or "two-course" floors are usually selected so that the final finish can be delayed until all other work is virtually complete. This eliminates the necessity for special protection; however, the rough slab should be protected against spillage of liquids or other materials which might later interfere with bonding of the floor topping. The surface of the base slab should be prepared for the topping in the same manner as the surface of any horizontal construction joint.

*c. Tolerance requirements for surface finish.*

(1) General. Control of surface tolerance may be critical in some types of structures such as warehouse guideway surfaces and surfaces subject to high-velocity flow (over 40 ft/s). There are two approaches in controlling the floor surface tolerance; using straightedge (or curved templates for curved surfaces) or measuring the F numbers in accordance with ASTM E 1155 (CRD-C 641). Both approaches are used in Corps of Engineers (CE) specifications depending upon the type of structures.

(2) Control surface tolerance by straightedge. This is the traditional method for measuring surface tolerance. The tolerance is defined as the maximum gap between a fixed length straightedge and the concrete surface at any point. The device is simple, portable, and easy to use. There will be no calculation or data collection. This procedure can be used on any surface; horizontal, vertical, overhead, even curved surface (by using a curved template). However, there are some limitations on this approach. The measurements are arbitrary, subjective, and generally nonrepeatable. There is no mention of the number of measurements to be made and therefore it totally depends on the operator. The difficulty in enforcing the requirement using this method often results in controversies between owners and contractors. This procedure is specified for mass-concrete structures and minor concrete structures and may be specified as an option in cast-in-place concrete structures in CE civil works projects. For mass-concrete

structures, the requirement of surface tolerance falls into two extremes. The surface tolerances for most mass-concrete structures, such as surfaces of a dam or floors of a lock chamber or gallery, are less critical where tight control is not necessary. Although a 10-ft straightedge has been commonly used in the industry, a 5-ft straightedge is specified for mass concrete due to the difficulty in handling the 10-ft straightedge on surfaces other than floors. On the other extreme, the surface subject to high-velocity water flow requires extreme tight control in surface tolerance to reduce the possibility of cavitation and erosion. A special surface class (Class AHV) has been created for this purpose. The straightedge or curved template is specified in this case since most of the surfaces involved are either vertical, overhead, or curved where the F-number system cannot be used. For minor concrete structures where a small quantity of concrete is used, the control of surface tolerance is less critical. The use of the F-number system in these structures is not necessary.

(3) Control floor tolerance by F-number system. In 1987 ASTM issued a standard test procedure, ASTM E 1155, for measuring floor surface profiles and for estimating the characteristic flatness and levelness of a floor. This procedure measures elevations at regular intervals along straight lines on the surface. The differences in elevations between adjacent points and between all points 10 ft apart are then calculated. The results of these calculations are analyzed statistically to obtain floor flatness number ( $F_F$ ) and floor levelness number ( $F_L$ ). Floor flatness is defined as the degree to which a surface approximates a plane while levelness is defined as the degree to which a surface parallels horizontal. These two numbers represent the average quality of floor finish in a predefined area and are reliable and repeatable. It should be noted that there is no direct correlation between straightedge tolerances and F-numbers. However, based on the effort required to finish a floor to the corresponding tolerance, Table 8-1 provides a rough correlation between the two systems. The F-number system may be specified as an option for all cast-in-place concrete floors for consistency with industry standards and practices. Currently, the construction technology can achieve  $F_F$  25 at little or no additional cost. Therefore, for normal slab or floor construction,  $F_F$  should be at least 25.  $F_L$  should be used for slab on grade only, since the levelness of an elevated floor is beyond the control of the Contractor due to camber and deflection of supporting system. In some cases, it may be necessary to specify localized  $F_F/F_L$  in addition to the overall  $F_F/F_L$  to assure a uniform floor quality. Details and concept of the F-number system are available in ACI 302.1R, ACI 117R commentary, and ASTM E 1155.

**Table 8-1**  
**Floor Quality as Determined by**  
**F-Number System and Straightedge**

	F-Number	Gap Under an Uneveled 5-ft Straightedge, in.	Gap Under an Uneveled 10-ft Straightedge, in.
Bull floated	F <sub>F</sub> 12	3/8	1/2
Straightedged	F <sub>F</sub> 20	1/4	5/16
Flat	F <sub>F</sub> 32	1/8	3/16
Very flat	F <sub>F</sub> 50	1/16	1/8

#### 8-4. Curing

*a. General.* Early hydration proceeds at an acceptable rate only if the concrete is maintained at a high humidity. Thus, positive curing procedures are essential, especially for thin sections. Even in massive sections, the quality of the surface concrete is dependent upon adequate curing. The Contractor should present his plans for curing for approval well before concreting begins. During construction, these operations must be continually checked. Form curing, where no additional moisture is added, is not an acceptable method of curing. Where forms are left in place during curing, the forms should be kept wet at all times.

*b. Moist curing.* Proposed methods of keeping concrete surfaces continually moist by spray-pipe or fog systems, soaker hoses, ponding, or covering with damp earth, saturated sand, or burlap maintained in a damp condition in contact with the concrete are satisfactory. Plastic, aluminum, galvanized, or alloy pipe should be required to avoid rust stains on the concrete surfaces. Hand sprinkling is not satisfactory and should not be permitted except as an emergency measure. Water that will stain the concrete should not be approved unless it is not practical to furnish a nonstaining water. The Contractor should be required to clean surfaces permanently exposed to view if he uses water that stains.

*c. Membrane curing.* Areas cured by pigmented membrane-forming curing compounds are relatively easy to inspect and should be specified wherever possible. Uneven distribution of the compound is readily revealed by a nonuniform appearance. In those areas in which a nonpigmented compound is required such as surfaces to be exposed to view, a government quality verifier should be on hand during all spraying operations and should check

closely the uniformity of the application. In a hot, dry environment, the energy from the direct sunlight may raise the surface temperature significantly which will promote formation of shrinkage cracks on the surface. Therefore, when using nonpigmented curing compound, it is required that shading should be provided for 3 days whenever the maximum ambient temperature during that period is expected to be higher than 90 °F. Compressed air lines must have traps to prevent moisture or oil from contaminating the compound. Ordinary garden hand-spray outfits are not satisfactory and should not be permitted. Application by brushing or rolling should not be permitted. Pigmented compounds should be thoroughly mixed in the receiving containers by the insertion of a compressed air pipe into and near the bottom of the container prior to withdrawing the material for use. Continuity of the membrane coating must be maintained for the duration of the full specified curing period. The membrane should be protected by suitable means if traffic thereon is unavoidable. Any damage to the membrane during the curing period should be immediately repaired at the original specified rate of coverage. Additional information may be found in ACI 308.

*d. Sheet curing.* Sheet curing is an acceptable curing method, although it is not often used except for curing slabs. Some of the materials used are easily torn by equipment or by wind, and constant inspection and maintenance is required. It is important that very secure tiedowns or heavy objects be used with this system to maintain a sealed environment for curing the concrete. Polyethylene film is easily torn and tends to leave a pattern on the surface where the film wrinkles. Maintenance of the film during the curing period is a constant problem due to wind and construction activity. Inspection requires constant scrutiny. It is not allowed except for smaller jobs.

1 Feb 94

### 8-5. Cold-Weather Concreting

*a. General.* Cold weather is defined by ACI 306R as a period of three or more consecutive days when the average daily ambient temperature is less than 40 °F, and the ambient temperature is not greater than 50 °F for more than one-half of any 24-hr period. The average daily air temperature is the average of the highest and the lowest temperatures occurring during the period from midnight to midnight. The objectives of cold-weather concreting practices are to:

- Prevent damage to concrete due to freezing at early ages.
- Assure that the concrete develops the required strength for safe removal of forms, shores, and reshores and for safe loading of the structure during and after construction.
- Maintain curing conditions which foster normal strength development without using excessive heat and without causing critical saturation of the concrete at the end of the protection period.
- Limit rapid temperature changes, particularly before the concrete has developed sufficient strength to withstand induced thermal stresses.
- Provide protection consistent with the intended serviceability of the structure.

Proper cold-weather concreting practices and procedures are based on the principles that:

- Concrete that is protected from freezing until it has attained a compressive strength of at least 500 psi will not be damaged by a single freezing cycle.
- Where a specified concrete strength must be attained in a few days or weeks, protection at temperatures above 50 °F is required.
- Little or no external supply of moisture is required when concrete is properly protected and sealed during cold weather except within heated protective enclosures.

*b. Planning.* Proper planning by the contractor to protect fresh concrete from freezing and to maintain temperatures above the required minimum values should be made well before the freezing temperatures are expected to occur. Equipment and materials required to protect concrete from freezing should be at the job site before cold weather

is likely to occur, not after the concrete is placed and its temperature begins to approach the freezing point. All surfaces that will be in contact with newly placed concrete should be at temperatures that cannot cause early freezing or seriously prolong setting time of the concrete. Ordinarily, the temperatures of these contact surfaces, including subgrade materials, need not be higher than a few degrees above freezing.

*c. Protection system.* ACI 306R provides guidance on minimum concrete placing temperatures and on the maintenance duration of these temperatures. The actual temperature at the concrete surface determines the effectiveness of protection, regardless of the ambient temperature. Therefore, monitoring concrete temperatures at several locations along the concrete surface, particularly at corners and edges, is important. As noted in paragraph 4-2d of this manual, concrete should not be exposed to cycles of freezing and thawing while in a critically saturated condition until it has attained a compressive strength of approximately 3,500 psi. The specific protection system required to maintain concrete temperatures above freezing depends on such factors as the ambient weather conditions, the geometry of the structure, and the mixture proportions. In some cases, covering the concrete with insulating materials to conserve the heat of hydration may be all the protection that is necessary. Insulation must be kept in close contact with the concrete or the form surface to be effective. Some commonly used insulating materials include polystyrene foam sheets, urethane foam, foamed vinyl blankets, mineral wool, or cellulose fibers, straw, and commercial blanket or batt insulation. In more extreme cases, i.e. ambient temperatures less than -5 °F, it may be necessary to build enclosures and use heating units to maintain the desired temperatures. Heat can be supplied to enclosures by live steam, forced hot air, or combination heaters of various types. Although steam provides an excellent curing environment, it may offer less than ideal working conditions and can cause icing problems around the perimeter of the enclosure. Heaters and ducts should be positioned not to cause areas of overheating or drying of the concrete surface. Combustion heaters should be vented for safety to prevent reaction of carbon dioxide in the exhaust gases with the exposed surfaces of newly placed concrete.

*d. Curing.* Concrete exposed to cold weather is not likely to dry at an undesirable rate unless the protection which is selected for use increases the likelihood of rapid drying. Measures should be taken to prevent drying when concrete is warmer than 60 °F and exposed to air at 50 °F or higher. Either steam or a liquid membrane-forming curing compound should be used to retard moisture loss

from the concrete. Water curing should not be used since it increases the likelihood of concrete freezing in a critically saturated condition when protection is removed.

*e. Accelerating early strength.* Accelerating admixtures, Type III portland cement, or additional cement can be used to shorten the times needed to achieve setting and required strength if proper precautions are taken. Reduction in time of setting and acceleration of strength gain may permit shorter protection periods, faster reuse of forms, earlier removal of shores, or less labor in finishing of flatwork. The acceleration of strength development of mass concrete should not be allowed since doing so will tend to increase internal temperature rise of the concrete. A more thorough discussion of all topics related to cold weather concreting is given in ACI 306R.

## 8-6. Hot-Weather Concreting

*a. General.* ACI 305R defines hot weather as any combination of the following conditions that tend to impair the quality of freshly mixed or hardened concrete by accelerating the rate of moisture loss and rate of cement hydration, or otherwise resulting in detrimental results:

- High ambient temperature.
- Low relative humidity.
- Wind velocity.

Hot weather may lead to concrete mixing, placing, and curing problems which adversely affect its properties and serviceability. Most of these problems relate to the increased rate of cement hydration at higher temperature and the increased evaporation rate of moisture from the freshly mixed concrete. Detrimental effects of hot weather on freshly mixed concrete may include increases in: water demand, rate of slump loss, rate of setting, tendency for plastic shrinkage, and difficulty in controlling air content. Hardened concrete may potentially experience decreased 28-day and later age strengths, increased tendency for drying shrinkage, and differential thermal cracking, decreased durability resulting from cracking, increased permeability, and greater variability of surface appearance. In addition, proper temperature control of mass concrete may be more difficult to achieve during hot weather.

*b. Planning.* Damage to concrete caused by hot weather can never be fully alleviated, and so good judgment is necessary to select the most appropriate compromise of quality, economy, and practicability. The type of construction, characteristics of the concrete materials, and

the hot-weather concreting experience of the Contractor all affect the procedures used to minimize potential problems. Lack of hot-weather concreting experience by the Contractor's personnel usually causes the most difficulties in achieving concrete of the required quality. Early preventative measures should be applied with the emphasis on materials evaluation, advanced planning, and coordination of all phases of the work. Detailed procedures for mixing, placing, protecting, curing, temperature monitoring, and testing of concrete during hot weather should be submitted by the Contractor prior to the beginning of hot-weather concreting. The potential for thermal cracking, either from overall volume changes or from internal restraint, should be anticipated. Items that should be considered to control cracking include limits on concrete temperature, cement content, heat of hydration of cement, form-stripping time, selection and dosage rate or quantity of chemical admixtures and pozzolans, joint spacing, and use of increased amounts of reinforcing steel.

*c. Alleviating measures.* Practices and measures which will help to reduce or avoid the potential problems of hot-weather concreting include:

- Using concrete materials and proportions with satisfactory records in field use under hot weather conditions.

- Using cooled concrete. For general types of construction in hot weather, it is not practical to recommend a maximum limiting ambient or concrete temperature because circumstances vary widely. Therefore, ACI 305R recommends that, if possible, a practical maximum concrete temperature of between approximately 75 and 100 °F be determined. This should be done by testing laboratory trial batches of concrete which are produced at the selected limiting temperature or at expected job site high temperature. For projects using CW 03305, "Mass Concrete," the maximum placing temperature for concrete in the massive features should be determined by a thermal study. For all other concrete, the maximum placing temperature should be as shown in Table 8-2, which relates maximum concrete temperature to relative humidity.

- Using a concrete consistency that permits rapid placement and effective consolidation.

- Transporting, placing, consolidating, and finishing the concrete with the least delay.

- Scheduling placing operations during times of the day or night when weather conditions are favorable.

1 Feb 94

**Table 8-2**  
**Maximum Placing Temperature**

Average Annual Relative Humidity, %	Maximum Concrete Temperature, °F, at Placement
>60	90
40-60	85
<40	80

NOTE: If the period that the concrete placements may occur can be anticipated, then the Weather Service Office in the project area should be asked to supply an average monthly relative humidity for that period.

• Protecting concrete against moisture loss at all times during placing, finishing, and during its curing period.

*d. Placing temperature.* The problems of placing concrete in hot weather involve, among other things, slump loss during mixing and transporting and surface crazing after placement. To reduce these problems, limits are placed on the concrete placing temperature in the guide specifications. The temperatures that are selected for inclusion in each paragraph are dependent on the normal relative humidity in the project area. The required maximum placing temperature may be lower if required by thermal studies and included in the appropriate DM.

*e. Plastic-shrinkage cracks.* Plastic-shrinkage cracking is often associated with hot-weather concreting, particularly in arid climates. It occurs primarily in flatwork, but beams and footings are also susceptible if the evaporation rate exceeds the rate of bleeding. Plastic-shrinkage cracking is easily identified since it begins to appear before the concrete completely hardens. The cracks appear in a random pattern on the surface and are wide at the surface, tapering to nothing at a shallow depth. The cracks may be up to 1/4 in. (6 mm) wide at the surface and seldom more than 4 to 6 in. (100 to 150 mm) deep. High concrete temperatures, high ambient temperatures, high wind velocity, and low relative humidity, alone or in combination, cause rapid evaporation of water from the concrete surface and significantly increase the probability of plastic-shrinkage cracking. ACI 305R provides a graphical means for making evaporation rate estimates based on all the major factors that contribute to plastic-shrinkage cracking. A close approximation of evaporation rate can also be made in the field by evaporating water from a shallow pan of known surface area. Initial and subsequent weighings made to the nearest 0.1 g every 15 to 20 min allow the evaporation rate to be calculated in a reasonably short period of time prior to concrete placement. When the evaporation rate approaches 0.2 lb/ft<sup>2</sup>/hr, precautions should be taken by the Contractor

to reduce moisture loss, or plastic-shrinkage cracking may occur.

*f. Effect on strength and durability.* Concrete material properties and the concrete mixture proportions have a significant effect on both fresh and hardened properties of concrete placed during hot weather. High mixing water temperatures cause higher concrete temperatures which, in turn, increase the amount of water needed to achieve a given slump. If additional water is added so that the w/c is increased, the strength and durability of the concrete may be detrimentally affected. A 1-in. slump decrease may typically be expected for every 20 °F increase in concrete temperature. The increase in water content necessary to maintain concrete slump in hot weather will range between 2 and 4 percent depending on the concrete temperature. This increase may be significantly less if WRA or HRWRA is used. The use of a slower setting Type II portland cement may help improve the handling characteristics of concrete in hot weather; however, concrete made with slower setting cements may be more likely to exhibit plastic-shrinkage cracking. Because the cement makes up only 5 to 15 percent of the mass of a concrete mixture, its temperature has a relatively minor effect on concrete temperature. An 8 °F increase in cement temperature is typically required to increase concrete temperature 1 °F. If the cement has a false set tendency, slump loss may be aggravated in hot weather. Retarding WRA and HRWRA have all been beneficial in offsetting some of the undesirable effects of hot weather on concrete. Admixtures without a performance history with the concrete materials selected for the work should first be evaluated in laboratory trial batches at the expected high temperature, using procedures described in ACI 305R. Some HRWRA's may not demonstrate their potential benefits when used in small laboratory batches. Further testing may then be required in full-size batches. Since concrete contains a relatively large mass of coarse aggregate, changes in its temperature have a considerable effect on concrete

temperatures. For example, a 1.5 to 2 °F coarse aggregate temperature reduction will lower the concrete temperature about 1 °F. Therefore, cooling coarse aggregate is a very effective means of lowering concrete temperature.

*g. Cooling.* If limiting temperatures govern the delivery of the concrete, the availability of cooled concrete should be ascertained well in advance of the need. Cooling of the concrete will require installation of special equipment and assurance of an ample supply of cooling materials such as ice or liquid nitrogen for the anticipated concrete volume and placement rate. Maintaining a continuous flow of cooled concrete to the placement is important to avoid the possible development of cold joints. Arrangements should be made for the ready availability of backup placing equipment and vibrators in the event of mechanical breakdowns. Arrangements should be made for ample water supply at the site for wetting subgrades, fogging forms, and for moist curing, if applicable. The fog nozzles used should produce a fog blanket and should not be confused with common garden-hose nozzles. Materials and means should be on hand for erecting temporary windbreaks and shades as needed to protect the concrete against drying winds and direct sunlight. The materials and means for the curing

methods selected should be readily available at the site to permit prompt protection of all exposed concrete surfaces from drying upon completion of the placement.

*h. Curing.* Proper moist curing of concrete placed in hot weather is the best curing method for assuring strength development and minimizing drying shrinkage. It can be provided by ponding, covering with prewetted burlap or cotton mats, covering with clean sand kept continuously moist, or continuous sprinkling. The use of a liquid membrane-forming curing compound may be more economical and practical than moist curing in many instances. Properly applied pigmented membrane-forming curing compounds provide good protection from direct sunlight. On flatwork, application should be started immediately after disappearance of the surface water sheen after the final finishing operation. Forms should be covered and kept continuously moist during the early curing period. They should be loosened, as soon as practical without damaging the concrete, and provisions made for curing water to run down inside them. A thorough discussion of curing and other topics related to hot-weather concreting is given in ACI 305R.

## Chapter 9 Concrete Quality Verification and Testing

### 9-1. Quality Verification

*a. General.* The construction quality verification system is necessary to assure the Government that the finished work complies with the plans and specifications. The inclusion of quality control requirements for the Contractor does not relieve the Contracting Officer of the responsibility for safeguarding the Government's interest. For civil works concrete construction, the resident engineer has the added responsibility for obtaining the quality of concrete in the various parts of the structure based on explicit instruction from the engineering division of the district office (see Chapter 6 of this manual). Depending on the scope of the work and the guide specification selected, the Government may or may not select the mixture proportions, but in all cases, the Contracting Officer is responsible for assuring that the strength and other requirements as set forth in the specifications or in the designer's instructions to the field personnel are met. The Contractor will mold, cure, and perform strength testing of concrete cylinders as part of his quality control program. The Government will perform compressive strength testing as part of the quality assurance program. In case of arch dams, all strength testing will be molded, cured, and performed by the Government. The budget for these GQA responsibilities should be included in the Project Management Plan. Details of requirements and procedures for CQC and GQA are specified in ER 1180-1-6, "Construction Quality Management," which contains detailed requirements for controlling projects with prescriptive specifications such as the mass-concrete specification. The GQA responsibility is not to be imposed on the construction contractor. If personnel shortages preclude the use of government personnel to accomplish GQA, it should be done by a commercial testing organization under contract to the Government.

*b. Government quality assurance.* During the construction stage, the Contracting Officer, through his authorized representatives, which include the resident engineer and his staff, is responsible for acceptance testing and quality verification to enforce all specification requirements and for monitoring the Contractor's quality control operations. These functions include but are not limited to: verification of all operations for compliance with specifications, reviewing and, when required, approving contractor submittals including certificates of compliance and contractor-developed mixture proportions. If acceptance testing of cement, pozzolan, slag, admixtures, or curing compounds are required, the resident engineer is responsible

for making the necessary arrangements for such tests with the appropriate division laboratory, or in the case of cement, pozzolan or GGBF slag, with WES. The resident engineer is responsible for requesting the division laboratory to verify the quality of the government project laboratory, any commercial laboratories operating under contract to the Government and the contractor's quality control laboratory as required by ER 1110-1-261, "Quality Assurance of Laboratory Testing Procedures."

(1) Quality assurance representative. This individual may be a government employee or may be an employee of a private engineering firm under contract to the Government and not affiliated with the construction contractor. He is the key figure in the operations attendant to concrete quality assurance. The effectiveness of the quality verification operation in assuring uniformity of the concrete and in obtaining compliance with specification requirements depends to a large degree on the thoroughness with which the quality assurance representative is instructed and trained in the performance of his duties. While it is expected that the quality assurance representative will have knowledge of the basic requirements for the production of concrete of high quality, it is nevertheless necessary to instruct him in the details of quality verification as they apply to each specific project. This should be accomplished through training conferences together with written guides and instructions prepared by the government concrete engineer and his shift supervisors or by the project engineer on smaller projects. Previous experience on similar work is highly desirable. Previous experience cannot entirely compensate, however, for proper instruction and training of quality assurance representatives in the duties unique to a particular project. These representatives should be assigned to a project prior to completion of the contractor's concrete plant. Preferably, they should be trained for duty on a particular project as the concrete plant is being erected so that they may become thoroughly familiar with the plant and particularly those aspects of the equipment bearing on the quality verification procedures. For example, on a large concrete project the mixing plant quality assurance representative should become familiar with the mixing plant and all of its operating features. All persons assigned as quality assurance representatives should be certified by ACI or have equivalent training. EP 415-1-261 provides detailed responsibilities and a check list for the GQA representative.

(2) Testing technicians. Technicians, either government employees or employees of a private engineering firm contracted by the Government, are responsible for the quality assurance testing to verify the Contractor's quality control tests and for acceptance testing of the concrete. They are also responsible for obtaining



1 Feb 94

samples of materials for other laboratories. All work done by technicians must be done in strict accordance with applicable standards to ensure the validity and acceptance of test results. Certification of concrete technicians is provided by ACI. This certification can be obtained by completing a 3- or 4-day course offered by ACI at announced times in many of the major cities of the country or by completing the Concrete Technicians Course at WES. All persons assigned as concrete technicians and responsible for quality assurance testing should be certified by ACI or have equivalent training.

(3) Organization.

(a) General. The Government's quality assurance organization must be flexible to allow for changes in rates of placement as construction progresses. In general, the following organizations should be provided by the Government to satisfy the area/resident engineer's responsibility for acceptance testing and quality verification to enforce all specification requirements and for monitoring the contractor's quality-control operations.

(b) Major concrete project. On large concrete projects, the organization should have a materials engineer (or technician) reporting directly to the resident engineer and being responsible for all phases of quality assurance from aggregate production through curing and protection of the concrete. The organization should include a shift supervisor (quality assurance representative) for each shift. Under each shift supervisor, the organization should include one placing quality assurance representative for each location at which concrete is being placed, one mixing plant quality assurance representative, and one quality assurance representative assigned to verification of cleanup, curing, protection, and finishing. The organization should include a laboratory technician and assistants as required to handle acceptance testing of aggregates and concrete, to consolidate reports, prepare summary reports, and keep records. The laboratory technician should report directly to the materials engineer. On a very large project, several contracts on the same project may be supervised by a single area engineer. Under such circumstances, the engineer reports to the resident engineer and supervises all concrete activity on the project. The quality assurance force required for aggregate quality verification depends upon job conditions. Where the Contractor's quality control has been proven satisfactory, sampling should be required only at the point of acceptance (mixing plant) and the quality verification should consist only of routine observation of plant operations; this work can be handled jointly by the shift supervisors and the engineers or by special assignment. Usually quality

verification of aggregate processing operations does not require continuous assignment of personnel.

(c) Moderate concrete volume. For smaller projects, it is necessary to modify the organization to suit the project conditions. In most instances, quality assurance representatives are required to serve in dual capacities, shifting from quality verification of concrete mixing and placing to other phases of the work as required. Quality assurance representatives may also be required to verify curing, protection, and cleanup. It is desirable to have continuous quality verification of batching and mixing operations.

(d) Ready-mix operations. When concrete is centrally mixed at the plant, a quality assurance representative should be on duty full time at the plant where he can observe and test the mixed concrete and can reject concrete which fails to meet job requirements. When concrete is transit-mixed, full-time plant quality verification is desirable, but primary responsibility for acceptance of concrete belongs to the quality assurance representative at the site of the work. If full-time plant quality verification is not possible, the plant should be visited frequently to ensure that batching is carried out properly.

(e) Small job. There is a tendency to overlook small jobs and the small parts of large jobs. Frequently, small structures such as curbs and sidewalks have very severe exposure and require concrete of high durability. Although a quality assurance representative on a small job may have duties other than concrete quality verification, no concrete placing should be started without a quality assurance representative on hand.

(4) Records. The value of clear, concise, and complete records is sometimes overlooked during the construction of a project. In devising a system of reports, and preparing forms for these reports, it should be realized that these reports will constitute a part of the official record of the construction operations and may be the sole source of reliable information on the procedure, practices, and results obtained during construction. Reports in various forms should be made daily and at other stated intervals for several purposes. Standard forms are available for reporting most test results. Where necessary, special forms may be devised on the project to suit project requirements. Reports will supply information on, and preserve as a permanent record, facts concerning progress of the work, factors affecting progress, instructions given to contractors, samples secured, tests made, and any other necessary data. Unusual occurrences in the plant may be noted on the recorder chart by the quality assurance representative or plant operator.

The information should ultimately appear in a report. The reports made by placing quality assurance representatives and quality assurance representatives engaged on cleanup, curing, finishing, and protection should follow a well-devised standard form on which the essential facts are recorded for the period of quality verification. Government test results should include control charts and variability of the material tested. Each such report form should also provide space for recording unusual happenings and for any pertinent remarks concerning shift operations.

## 9-2. Required Sampling and Testing for CQC and GQA

The following tests are normally required for a major civil works concrete construction project for CQC and GQA purposes. The procedures and frequencies of all the necessary CQC tests should be included in the contract specification. Tests for GQA are at the Government's discretion and should not be specified in the specification except those cases where sampling and facility are the Contractor's responsibility. The required frequencies for GQA and government acceptance tests should be included in the Engineering Considerations and Instructions to Field Personnel for each project. The recommended testing frequencies for GQA are listed in the following paragraphs.

*a. Aggregate grading.* In order to determine compliance with the specification requirement that aggregates must be within certain grading limits as delivered to the mixers, samples must be obtained as delivered to the mixer. On mass concrete projects containing 150-mm (6-in.) NMSA, the specifications require that an automatic small screening plant be included in the batch plant. On concrete projects containing 75-mm (3-in.) NMSA, a cost analysis should be made before specifying the automatic screening plant. The automatic screening plant makes use of angled quarry screens, which by their nature are 80-percent efficient at the best and cannot be compared directly to Gilson screens, which are 95- to 98-percent efficient. The automatic screening plant must contain controls to vary the angle and frequency (vibrations per minute) of each individual screen. Optimum loading, screen angle, and frequency of each screen must be established by the Contractor before construction begins. Correlation tests with Gilson sieving equipment must be performed before construction and every 60 days while concrete production continues. The quarry screens on the automatic screening plant will normally require a larger screen than the Gilson screens for comparable results. With such a device, the sampling, screening, determination of mass, and disposal is accomplished automatically. Normally, it is not necessary to procure samples at any other location. Samples may be

procured at any point in the production line where it is deemed necessary. Where 150-mm (6-in.) NMSA is used, it might not be feasible to sample the 75- to 150-mm (3- to 6-in.) fraction from the weigh batcher. Then samples may be obtained from the conveyor belt or other convenient place as close as possible to the end of the handling operations. When sampled from a conveyor belt, the belt should be stopped, and the sample should consist of a complete section and not hand-picked from the top. Where aggregates are supplied by a commercial producer located some distance from the project, sampling for acceptance tests will not be made at the producer's plant. Such tests would not reflect the possible effects of segregation in stockpiling at the project and breakage in handling.

### (1) Frequency.

(a) On-site plant. During each 8-hr shift when concrete is being produced, at least one sample of each size of aggregate should be taken. During the early stage of a large project, several samples per shift should be tested until the production control has achieved uniformity. After 1 month, if the Contractor's control testing has proven to be satisfactory, frequency of government sampling may be reduced to one-third of that stated above.

(b) Off-site commercial plant. The frequency of QA testing of the aggregate grading at an offsite commercial plant will vary somewhat with the quantity of concrete and the rate of concrete usage from that plant where concrete is supplied to many customers and the concrete mixture is furnished by the contractor. For minor concrete jobs, the aggregate should be tested before concrete placing begins and once per week while concrete is being placed. On larger structural concrete jobs, the aggregate grading should be tested by the GQA representative before start of concrete placement and at least twice per week thereafter while concrete is being placed.

(2) Size of samples. Sample sizes for sieve analysis are given in ASTM C 136 (CRD-C 103). For fine aggregates and finer sizes of coarse aggregate, samples obtained in accordance with CRD-C 100 may be reduced in size by a sample splitter or by carefully following instructions for quartering given in ASTM C 702 (CRD-C 118). For aggregate sizes smaller than 37.5 mm (1-1/2 in.), the required sample sizes are sufficiently large in relation to individual particle size so that compliance with the grading specification may be fairly determined by a single test. For 37.5 mm (1-1/2-in.) and larger sizes, however, this is not true. While sample sizes given in ASTM C 136 (CRD-C 103) for nominal maximum aggregate sizes larger than 37.5 mm (1-1/2 in.) are practical for laboratory sieve

analysis testing equipment, the samples are subject to large random sampling errors. Therefore, compliance with specification should be determined from the average of five consecutive tests. Whenever a single test result shows a major deviation from specification requirements, the frequency of sampling and testing should be accelerated to as great an extent as practical until it is established whether the indicated noncompliance was the result of sampling error or the result of an actual deficiency in the aggregate processing equipment. Sometimes a single retest will be sufficient to establish the cause of the noncompliance. If sampling and testing equipment is installed that is capable of handling specimens five times as large as those required by ASTM C 136, averaging of test results is not necessary.

*b. Aggregate quality - large project.* Paragraph 7-1 requires initial testing of the Contractor's chosen aggregate sources to confirm that the aggregate quality has not changed since it was tested in the design stage and to confirm that it meets aggregate quality specification requirements. Quality testing by the Government should be performed during the life of the contract at about 10 percent of the rate listed in the CQC requirements of the specifications. Tests performed by the Contractor under CQC should be monitored carefully by the GQA representative. Experience has shown that quality of aggregate can change, either gradually, or at times dramatically as production proceeds laterally and vertically in the source. Failing quality tests will require additional testing by the Contractor and by the Government. Resident office personnel should record and monitor the location in the quarry or pit from which the aggregate is being produced. A change in visual appearance or quality test results could signal a change in production location at the source.

*c. Free moisture on aggregates.* Adjustments of batch weights to compensate for variation in aggregate moisture is a basic contractor responsibility. The Contractor's methods for complying with this requirement should be reviewed and verified at least once weekly. Whenever the concrete is considered out of control due to slump or air content, the government testing should increase in a cooperative effort with the Contractor in obtaining testing information needed to perform the necessary adjustments. When a moisture meter is required by the specifications, its accuracy should be verified at least once per week.

*d. Slump and air content.* The slump test ASTM C 143 (CRD-C 5) is made as a check on the uniformity of the concrete and to determine whether the concrete being sent to the forms is placable. Samples for slump and air content

tests may be taken and tested at the batch plant for onsite plants; however, the required slump and air content is that required at the placement. If slump or air content loss is experienced, then occasional tests must be performed at the placement site to determine amount of slump loss or air content loss. In that case, slightly higher values may be adopted for use at the plant, so that the proper slump and air are obtained at the placement. Considerable slump loss and air content loss are usually associated with conveying or pumping concrete considerable distances. Correlation test samples for compressive strength is also necessary when considerable slump and air content loss is experienced. Variation in slump is caused chiefly by variation in aggregate moisture and air content. Whenever either or both of these factors vary, slump tests should be made as frequently as needed to ensure that the concrete is of the required consistency. When the mixture is of the required consistency, slump tests should be made at least twice per shift for each concrete mixture being placed. Control of air content is essential to the placeability and the durability of concrete. When no control problems are encountered, the air content should be determined at least twice per shift for each concrete mixture being placed. When the concrete contains a fly ash with a variable carbon content, the testing rate should be increased. After 3 months, if the Contractor's control has been adequate, slump and air content need to be measured by the Government only when cylinders are fabricated.

*e. Concrete temperature.* The temperature of cooled concrete should not be measured until 20 minutes after mixing. If the largest aggregate was cooled for an insufficient period of time, the particles may be only surface cooled. If so, this fact will be reflected in the delayed temperature reading. The sensing element of the thermometer should be at least 3 in. below the surface of the fresh concrete when the measurement is made. The temperature of each concrete mixture should be checked twice per shift when concrete is being placed.

*f. Compressive strength.*

(1) Purpose. Strength tests are performed for different purposes depending on the type of construction and the specification used. For mass-concrete structures where mixture proportioning is provided by the Government, strength tests are needed to measure the variability of the concrete mixture. In this case, strength is not necessarily the most critical factor concerning the concrete mixture. Other considerations, such as durability or thermal cracking, may dictate the w/c. Nevertheless, compressive strengths are good indications of variations in other concrete properties. For concrete structures where mixture

proportioning is the Contractor's responsibility, concrete strength is a part of the acceptance requirements. The strength criteria are normally determined by structural requirement.

(2) Testing responsibility. The specifications should require the Contractor to mold, protect, cure, and test compressive strength cylinders on all concrete construction where the Government furnishes the mixture proportions, except for arch dam construction where the Government will perform all the strength testing. The frequency of testing by the Contractor should be in accordance with paragraph 9-2f(4). In addition, the GQA representative should mold, cure, protect, and test at least 1 set of test cylinders for each 10 sets of cylinders made by the Contractor. The GQA test cylinders should be from the same batch of concrete as one of the CQC test cylinders. After a minimum of 30 sets of cylinders are tested, the resident engineer may choose to lower the amount of government-molded, -cured, and -tested cylinders to 5 percent (1 in 20) of the cylinders tested by the Contractor if the CQC tests are proven satisfactory. A 10-percent differential in the test results between CQC tests and GQA tests would be cause for further investigation of the Contractor's casting, curing, and testing procedures and equipment.

(3) Sampling plan. The frequency of sampling, number of cylinders made, and ages at which the cylinders are tested will vary with the type and size of the project. At the beginning of each project, a sampling plan will be developed by the Government that is consistent with the project specifications. The sampling plan should obtain information on the quality of each class of concrete at the least cost. The sampling plan must reflect the variability characteristics of heterogeneous concrete. The individual samples must be taken in such a manner that each sample is selected in an unbiased manner. The number of test specimens fabricated will depend on the number of ages at which they are to be tested. For part of the work, two specimens should be tested at the same age to derive the within-batch coefficient of variation. A test is defined as the average strength of all specimens of the same age, fabricated from a sample taken from a single batch of concrete. Samples should be obtained by means of a random sampling plan designed to minimize the possibility that choice will be exercised by the sampler. Probability sampling of materials is discussed in ASTM E 105 (CRD-C 579). This procedure should be used for guidance in developing a random sampling method. The sampling plan should also include the predetermined sampling location where representative samples will be obtained.

(4) Frequency and testing age. During the early stages of a project, it is desirable to increase the frequency of testing until control is established. Structural concrete should normally be sampled once per shift and mass concrete once per day for each concrete mixture placed. When mixture proportions are provided by a division laboratory, as would be the case of a large mass structure such as a lock or dam, accelerated strength testing should be used to control batching and mixing based on relationships developed by the laboratory. Two specimens will normally be molded and cured in accordance with ASTM C 684 (CRD-C 97), Method A. Where conditions are not suited to this method, Method B or C may be used. Laboratory mixture proportioning studies should be developed with the same method that will be used on the project. The design age should be decided by the designer depending on the type of structure involved, the types of cementitious materials and the loading conditions anticipated. As examples, the design age for a large lock or dam may be 180 days or even 1 year if design loadings are not likely to occur sooner. However, the design age for a bridge or pumping station will likely be 28 days and could possibly be shorter depending on the construction techniques used and the construction and in-service loadings anticipated. The information age could be selected to coincide with form-stripping schedules, removal of shoring, or in the absence of construction considerations at intervals such as 7, 14, or 28 days. In addition to control or acceptance cylinders, occasionally there will be a need for extra cylinders. With prestressed concrete, for example, when prestressing is to be applied when the concrete attains its loading strength, it will be necessary to test cylinders at various ages. Sometimes field-cured cylinders are used in determination of form removal time. A sampling plan guide for number and test age of cylinders is shown in Table 9-1.

(5) Sampling and testing methods. On all projects, concrete will be sampled in accordance with ASTM C 172 (CRD-C 4). The test specimens will be molded and cured in accordance with ASTM C 31 (CRD-C 11). When the nominal maximum size aggregate is larger than 50 mm (2 in.), the concrete sample shall be wet sieved in accordance with ASTM C 172 over a sieve having 50-mm (2-in.) square openings. Concrete test specimens will be tested in accordance with ASTM C 39 (CRD-C 14).

(6) Analysis of tests. Strength variation is the key consideration in analysis of data derived from tests of concrete cylinders. Because of this variation, statistical methods are used to analyze and present the numerical data. The magnitude of variations in the strength of concrete test specimens depends on how well the materials, concrete

**Table 9-1  
Number of Cylinders to Be Cast**

Concrete Type	Number of Test Specimens at Various Ages		
	1 Day	Information Age(s)	Design Age
Structural & minor		1	2
Mass	2	1	2

manufacture, and testing are controlled. The strength results will vary above and below an average and fall into some probability distribution. The strength test results should be evaluated to determine the within-batch-coefficient of variation and overall standard deviation. ACI 214 provides details on these methods of analysis. The procedures involve mathematical computations which lend themselves to computer processing. There are many commercial programs available for this purpose. The selection of appropriate computer programs for evaluating test data may be made with the advice of CECW-EG. The standards for control are shown in Table 9-2 for 28-day strength results. The standards for accelerated strength test results will be developed by the division laboratory based on an analysis of 28-day strength results and the accelerated strength test results. After the first 30 test results are available on the project, they should be analyzed for average strength and standard deviation and the mixture proportions adjusted as appropriate.

(a) Within-test coefficient of variation. Within-test coefficient of variation is caused by fabricating, curing, and testing the cylinders. When the coefficient of variation is greater than 5.0 percent, the following procedures should be evaluated:

- Sampling procedures
- Fabrication techniques
- Handling and curing cylinders
- Quality of molds
- Variation in curing temperatures
- Variation in curing moisture
- Delays in transporting to the laboratory
- Size of the test specimens
- Capping procedures

(b) Overall standard deviation. Overall standard deviation is a term representing a value related to both within-test variation and batch-to-batch variation. The overall standard deviation is defined as the square root of

the sum of squares of within-test and batch-to-batch standard deviations. The variation may be introduced by practices in proportioning, batching, mixing, and transporting concrete. When overall standard deviation is higher than 600 psi, the following procedures should be evaluated:

- Characteristics and properties of the ingredients
- Batching and mixing procedures
- Sampling procedures
- Causes for variation in w/c, such as aggregate moisture
- Causes for variation in water requirements

(7) Control criteria. On projects where mixture proportions were developed by the Contractor, the Contractor shall submit revised proportions when the compressive strength tests do not meet the specified criteria. On projects where mixture proportions were developed by a division laboratory, the area/resident engineer in concert with engineering division personnel should revise the proportions as necessary to meet the required average strength criteria. In both cases, adjustments to the procedures should be made after the first set of 30 tests if the overall standard deviation is approaching or beyond the limit of 600 psi.

(8) Prediction of later age strengths. Where possible, the division laboratory will develop an appropriate correlation of the relationship between accelerated tests and standard cured compression tests. At the start of concrete placement, testing should be performed at accelerated ages and later age. After the first 30 tests, the linear regression equation should be verified or reestablished. If there is a discrepancy between equations, the division laboratory should be consulted to analyze the data. As confidence is gained with predicting later age strength with the linear regression equation, the amount of later age testing may be reduced by as much as 50 percent.

**Table 9-2**  
**Standards of Control for Concrete Compressive Strength**

Class of Operation	Standards for Concrete Control				
	Excellent	Very Good	Good	Fair	Poor
Within test, coefficient of variation, percent	0 - 3.0	3.0 - 4.0	4.0 - 5.0	5.0 - 6.0	Above 6.0
Overall standard deviation, psi	0 - 400	400 - 500	500 - 600	600 - 700	Above 700

### 9-3. Nondestructive Testing

*a. General.* Nondestructive testing of concrete as described herein includes methods of tests on concrete structures or structural members which do not reduce the functional capability of the structure, although some of the methods listed do require minor repairs if the concrete will be exposed to view. The tests described are those which are used to gain an indication of the quality of hardened concrete in place.

*b. Policy.* Nondestructive testing will not be used in lieu of compressive strength tests of cylinders, air content tests by the pressure method, slump tests, or any other test for the evaluation and acceptance of concrete placed on any civil works projects.

*c. Applicability.* Nondestructive tests may be used to locate areas of unsound concrete or concrete suspected of being significantly below the specified levels of strength required by the design or the required levels of durability. If areas are located where unsound, weak, or deteriorated concrete is likely, the condition of the concrete may be confirmed by coring unless the structure is so heavily reinforced that useful specimens cannot be obtained. Nondestructive testing may also be used to indicate changes with time in characteristics of concrete such as those caused by the hydration of cement so that it provides useful information in determining when forms and shoring may be removed.

*d. Nondestructive testing methods.* The methods discussed do not represent all the available methods but only those that have been standardized by ASTM. More detailed

discussion of the advantages and limitations of these test methods is given in ACI 228.1R.

(1) Rebound hammer (ASTM C 805 (CRD-C 22)). The rebound hammer consists of a spring-loaded steel hammer which, when released, strikes a steel plunger in contact with the concrete surface, and rebounding indicates a rebound number on a calibrated scale. Only the concrete in the immediate vicinity of the plunger influences the rebound number; therefore, the test is sensitive to the local conditions where the test is performed. Because the rebound hammer tests only the near-surface layer of concrete, the rebound number may not be representative of the interior concrete. The probable accuracy in predicting concrete strength in a structure by this method is only  $\pm 25$  percent, so its use is clearly limited to attempting the differentiation between areas of large quality variation in the same structure. Closer accuracy can be obtained by calibrating the hammer with project concrete of known strength. The main advantage of the rebound hammer is its extreme portability so that many tests may be made easily in a short period of time.

(2) Penetration resistance (ASTM C 803 (CRD-C 59)). The penetration-resistance test uses a powder-driven stud to measure the penetration resistance of concrete. This test, like the rebound hammer, is a hardness tester; however, attempts continue to be made to correlate the penetration of the stud to concrete strength. The apparatus is easily portable, using a modified powder cartridge stud gun and studs or probes. The resulting damage to the concrete surface is minor and may be easily repaired. A large number of tests may be completed in a relatively short period of time. Attempts to correlate the penetration-resistance test results with core tests and cylinder tests

indicate coefficients of variation and range about 10 times as large as the core and cylinder test results. Therefore, the use of the this test should be limited to applications where large variations are suspected in the concrete quality or to determine the locations for borings.

(3) Cast-in-place pullout tests (ASTM C 900 (CRD-C 78)). Pullout tests use a hollow stem ram to pull a bolt with a washer on its lower end that has been cast in the concrete at the time of placement. The pullout assemblies are incorporated into the formwork for critical structural members. As an alternative, pullout assemblies may be cast into large blocks which are cast at the same time as the structural member and consolidated and cured in a similar way. The main advantage of the pullout tests is that it does produce a well-defined failure in the concrete and measures a static strength property of the concrete in a structure. The equipment is easily portable. The pullout strength does correlate with compressive strength; however, the coefficient of variation of pullout test results has been found to be approximately 7 to 10 percent. This is about two to three times greater than that of standard compressive strength tests. The main limitations are that the test locations are fixed at the time of placement which limits the usefulness of the pullout test in troubleshooting problems suspected after placement is completed and the necessity of repairing the surface which is marred by a crater about 6 in. across. Commercial inserts have embedment depths on the order of 1 to 2 in. Since the vibrator operator may notice where the inserts are, the consolidation of concrete around them may not be representative of the entire member.

(4) Maturity method (ASTM C 1074 (CRD-C 70)). Assuming sufficient moisture is present, the rate of hydration of the cementitious materials in a concrete mixture is influenced by the concrete temperature. Therefore, the strength of concrete at any age is a function of its thermal history. The maturity method accounts for the combined effects of temperature and time on strength development. The concrete thermal history and a maturity function are used to calculate a maturity value which quantifies the combined effects of time and temperature. Concrete strength is expressed as a function of its maturity by means of a strength-maturity relationship. So, if samples of the same concrete are subjected to different curing temperatures, the strength-maturity relationship for that concrete and the thermal histories of the samples can be used to estimate their strengths. The strength-maturity relationship must be established for the concrete to be used in the structure in order to use the maturity method. ASTM C 1074 describes the procedure to be followed in developing this relationship using the concrete of interest. The temperature of history of the in-place concrete is continuously monitored, and from

these data the in-place maturity is calculated. The in-place concrete strength can then be estimated at any point in time based upon the concrete maturity at that same time and the strength-maturity relationship. Commercial instruments are available which automatically compute concrete maturity; however, care should be exercised in their use since the maturity function used by the instrument may not be applicable to the concrete in the structure. To use the maturity method to estimate in-place concrete strength, there must be sufficient moisture for continued hydration, and the concrete in the structure must be the same as that used to develop the strength-maturity relationship. Proper curing assures the first condition will be met, and conducting slump, air content, unit weight, and accelerated strength tests on concrete representative of that going into the structure will assure the latter condition is met. The maturity method has obvious applications in the control of form stripping, shoring removal, and termination of cold-weather protection.

(5) Cores (ASTM C 42) (CRD-C 27). Coring is usually the method ultimately chosen to determine the in-place characteristics of concrete especially if the dispute involves payment to the Contractor or other problems such as the location of the member or the amount of reinforcement present. Planning for the core sampling and laying out the drill holes should follow (ASTM C 823 (CRD-C 26)). In heavily reinforced structures, it may be impossible to obtain a core sample from which compressive strength specimens may be taken since reinforcing steel may be so prevalent in the concrete that cores free of reinforcing steel and having height-to-diameter ratios equal to 1 or more cannot be obtained. It may be possible, however, to obtain specimens from such cores which will allow a determination of air-void system parameters (ASTM C 457 (CRD-C 42)) or analysis for the products of reactivity. Additionally, the effect of severing reinforcing steel on the integrity of the structure should be analyzed. If possible, the size of the core taken should be related to the nominal maximum size aggregate in the structure. If 37.5-mm (1-1/2-in.) maximum size aggregate is used in the structure then 6-in. cores should be drilled. In structures using larger aggregate, it may be practical to take cores up to 18 in. in diameter, but costs increase rapidly and the large core usually cannot be taken to a depth of more than 3 or 4 ft. Coring may prove expensive and the holes have to be backfilled, but the resulting data are usually accepted as the best evidence of the condition of the concrete in place.

(6) Pulse velocity method (ASTM C 597 (CRD-C 51)). This method involves the application of a mechanical impulse to a solid mass of material. The speed of the waves which are subsequently generated and which pass through the material are dependent on the elastic properties

of the material. The pulses can be generated either by a hammer blow or by an electroacoustic transducer. The pulse velocity method may be used to determine the uniformity of concrete. However, a number of factors affect pulse velocity measurements, including concrete moisture content and the presence of reinforcing steel. Reinforcing steel may be especially troublesome if it is oriented parallel to the pulse-propagation direction. The resulting apparent velocity through such a member will be greater than the actual velocity through the concrete. Failure to account for the presence and orientation of reinforcing steel may lead to inaccurate conclusions regarding the concrete quality. While pulse-velocity equipment is commercially available, its use and the interpretation of the pulse-velocity measurements requires special training and techniques.

(7) Other methods. Other methods in addition to those above are in the development stages. Contact WES for additional information.

#### 9-4. Preplacement Quality Verification

The quality of all concrete placement areas should be verified prior to the actual placement of any concrete. For complicated placements, these quality verifications should be made as each element of the preparation for actual placement is completed. That is, foundation preparation, joint preparation, form installation, the placement of reinforcing bars, all embedded metal work, waterstops, conduits, mechanical piping, and cleanup should be verified for quality and checked out as each is completed. Other items that must be kept in mind at all times during all phases of this work are the provisions for safety and access to the placements, including all scaffolding, walkways, work platforms, ladders, and railings along with whatever weather protection and drainage provisions are required. If each element of this preparation is thoroughly verified as it is completed, it will then only require a cursory verification immediately prior to the concrete placement to be assured that the conditions have not changed. On a small or simple placement, the final quality verification may be all that is required prior to concrete placement. These preplacement verifications will be more systematic and accurate if a checklist is used. This checklist is to be initiated and dated by the representatives of the Contractor and the Government as each element in this preparation is completed. These checklists are known by various names, such as lift checkout cards and form checkout cards. The format of these checklists can vary according to the project requirements and the practice of the individual districts. All essential information is recorded. A separate form or checkout card is to be prepared for each concrete placement and retained in the Government's official project files. The

Guide Specifications "Mass Concrete" (CW-03305) and "Cast-In-Place Structural Concrete" (CW-03301) also require the Contractor to provide a written report certifying that all elements of the placement are ready to receive concrete. While it has become the practice in some districts and divisions for the Contractor's representative and the Corps' quality assurance representative to jointly verify and sign the checkout card, it should be kept in mind that this is, in fact, the sole responsibility of the contractor and not be inferred as a joint responsibility. The advantage of a jointly signed card is that it establishes the means by which both the Corps' quality assurance representative and the contractor's quality control representative will be satisfied that the elements of the placement meet the project specification requirements before the concrete placement begins. Figure 7-1 is an example of a form checkout record.

#### 9-5. Project Laboratory

*a. General.* A government field laboratory should be provided as close as possible to the mixing plant. The building housing the laboratory normally includes office space for the concrete personnel and facilities for filing the project concrete records.

*b. Space requirements.*

(1) Large-volume mass concrete project. At least 1,000 ft<sup>2</sup> of work space, exclusive of office space, should be provided for major mass concrete projects where it is expected that concrete will be placed on a continuous day-to-day basis throughout the construction season.

(2) Other. At least 500 ft<sup>2</sup> of work space, exclusive of office space, should be provided for moderate size projects.

*c. Equipment.*

(1) Large-volume mass concrete project. Storage tanks with a capacity of 300 cylinders and a 200,000-lbf compression testing machine, complying with requirements of ASTM C 39 (CRD-C 14), should be provided. New machines being purchased and older machines, returned to the manufacturer for repair, should be required to comply with the 1-percent accuracy requirement. Older machines, which are not under manufacturer's warranty and are presently in use, should be required to comply with a  $\pm$  3-percent accuracy requirement. Aggregate testing equipment should include that equipment necessary to perform tests for absorption, density, surface moisture, and sieve analysis. Heavy-duty laboratory screening equipment, such as the Gilson for coarse aggregate and the Ro-Tap for fine



**EM 1110-2-2000**

**1 Feb 94**

aggregate, should be provided. Concrete testing equipment includes that equipment necessary for determining air content and slump and for molding test specimens. The laboratory should not include a concrete mixer.

(2) Other. Moderate size projects should include a curing tank with a capacity of 100 cylinders. If a compression testing machine is not available, cylinders may

be shipped to either a division laboratory or large-volume project for testing. Aggregate and concrete testing equipment should be the same as for a large project. The laboratory facilities for a small project should be limited to equipment for measuring air content and slump and for molding test specimens. Curing of test cylinders and transportation to the laboratory for testing must be in strict accordance with ASTM C 31 (CRD-C 11).

## Chapter 10 Special Concretes

### 10-1. General

For purposes of this manual, special concretes are considered to be those which contain materials that are not routinely used in conventional structural or mass concrete, those which are not proportioned using procedures given in CRD-C 99, or those which are placed with equipment or by methods which require additional attention be given by the Contracting Officer to assure the required quality is achieved. Those special concretes for which detailed guidance is given in other Corps publications are not discussed in this chapter.

### 10-2. Preplaced-Aggregate Concrete

*a. General.* Preplaced-aggregate (PA) concrete is produced by placing coarse aggregate in a form and later injecting a portland-cement-sand fly ash grout, usually with chemical admixtures, to fill the voids. The smaller-size coarse aggregate is not used in the mixture to facilitate grout injection. It is primarily applicable to the repair of existing concrete structures. PA concrete may be particularly suitable for underwater construction, placement in areas with closely spaced reinforcing steel and cavities where overhead contact is necessary, and in areas where low volume change is required. It differs from conventional concrete in that it contains a higher percentage of coarse aggregate since the coarse aggregate is placed directly into the forms with point-to-point contact rather than being contained in a flowable plastic mixture. Therefore, hardened PA concrete properties are more dependent on the coarse aggregate properties. Drying shrinkage of PA concrete may be less than one-half that of conventional concrete, which partially accounts for the excellent bond between PA concrete and existing roughened concrete. The compressive strength of PA concrete is dependent on the quality, proportioning, and handling of materials but is generally comparable to that achieved with conventional concrete. The frost resistance of PA concrete is also comparable to conventional air-entrained concrete assuming the grout mixture has an air content, as determined by ASTM C 231 (CRD-C 41) of approximately 9 percent. PA concrete may be particularly applicable to underwater repair of old structures and underwater new construction where dewatering may be difficult, expensive, or impractical. Bridge piers and abutments are typical of applications for underwater PA concrete construction or repair. A detailed discussion of PA concrete is provided in ACI 304.R.

*b. Applications.* PA concrete has been used on different types of civil works construction including:

- (1) Resurfacing of lock chamber walls.
- (2) Underwater repair to lock guide walls.
- (3) Resurfacing of spillways.
- (4) Construction of plugs to close temporary sluices through a dam.
- (5) Filling of temporary fish ladders through a dam.
- (6) Scroll case embedment.

*c. Materials and proportioning.* Intrusion grout mixtures should be proportioned in accordance with ASTM C 938 (CRD-C 615) to obtain the specified consistency, air content, and compressive strength. The grout mixture should also be proportioned such that the maximum w/c complies with those given in Table 4-1. Compressive strength specimens should be made in accordance with ASTM C 943 (CRD-C 84). Compressive strength testing of the grout alone should not be done to estimate the PA concrete strength because it does not reveal the weakening effect of bleeding. However, such testing may provide useful information on the potential suitability of grout mixtures. The ratio of cementitious material to fine aggregate will usually range from about 1 for structural PA concrete to 0.67 for mass PA concrete. A grout fluidifier meeting the requirements of ASTM C 937 (CRD-C 619) is commonly used in the intrusion grout mixtures to offset bleeding, to reduce the w/c and still provide a given consistency, and to retard stiffening so that handling times can be extended. Grout fluidifiers typically contain a water-reducing admixture, a suspending agent, aluminum powder, and a chemical buffer to assure timed reaction of the aluminum powder with the alkalis in the portland cement. Products proposed for use as fluidifiers which have no record of successful prior use in PA concrete may be accepted contingent on successful field use. ASTM C 937 requires that intrusion grout made as prescribed for acceptance testing of fluidifiers have an expansion within certain specified limits which may be dependent on the alkali content of the cement used in the test. Experience has shown, however, that because of the difference in mixing time and other factors, expansion of the field-mixed grout ordinarily will range from 3 to 5 percent. If, under field conditions, expansion of less than 2 percent or more than 6 percent occurs, adjustments to the fluidifier should be made to bring the expansion within these limits. The fluidifier should be tested under field conditions with job

materials and equipment as soon as practicable so that sufficient time is available to make adjustments in the fluidifier if necessary. If the aggregates are potentially alkali reactive, the total alkali content of the portland cement plus fluidifier added to increase expansion should not exceed 0.60 percent, calculated as equivalent sodium oxide by mass of cement. The grout submitted for use may exhibit excess bleeding if its cementitious material to fine aggregate ratio is different than that of the grout mixture used to evaluate the fluidifier. Expansion of the grout mixture should exceed bleeding at the expected in-place temperatures. Grout should be placed in an environment where the temperature will rise above 40 °F, since expansion caused by the fluidifier ceases at temperatures below 40 °F. This condition is normally readily obtainable when PA concrete is placed in massive sections or placements are enclosed by timber forms. If an air-entraining admixture is used in the PA concrete, adjustments in the grout mixture proportions may be necessary to compensate for a significant strength reduction caused by the combined effects of entrained air and the hydrogen generated by the aluminum powder in the fluidifier. However, these adjustments must not reduce the air content of the mixture to a level that compromises its frost resistance. The largest practical NMSA should be used to increase the economy of the PA concrete. A 37.5-mm (1-1/2-in.) NMSA will typically be used in much of the PA concrete; however, provisions are made for the use of 75-mm (3-in.) NMSA when it is considered appropriate. It is not expected that many situations will arise where the use of aggregate larger than 50 mm (2 in.) will be practical. Pozzolan is usually specified to increase flowability of the grout.

*d. Preplacing aggregate.* Care is necessary in preplacing the coarse aggregate if excessive breakage and objectionable segregation are to be avoided. The difficulties are magnified as the nominal maximum size of the aggregate increases, particularly when two or more sizes are blended. Therefore, the Contractor's proposed methods of placing aggregate should be carefully reviewed to ensure that satisfactory results will be obtained. Coarse aggregate must be washed, screened, and saturated immediately prior to placement to remove dust and dirt, and to eliminate coatings and undersize particles. Washing in forms should never be permitted because fines may accumulate at the bottom.

*e. Contaminated water.* Contaminated water is a matter of concern when PA concrete is placed underwater. Contaminants present in the water may coat the aggregate and adversely affect the setting of the cement or the bonding of the mortar to the coarse aggregate. If contaminants in

the water are suspected, the water should be tested before construction is permitted. If contaminants are present in such quantity or of such character that the harmful effects cannot be eliminated or controlled, or if the construction schedule imposes a long delay between aggregate placement and grout injection, PA concrete should not be used.

*f. Preparation of underwater foundations.* Difficulty has been experienced in the past with cleanup of foundations in underwater construction when the foundation material was glacial till or similar material. The difficulty develops when as a result of prior operations, an appreciable quantity of loose, fine material is left on the foundation or in heavy suspension just above the foundation. The fine material is displaced upward into the aggregate as it is being placed. The dispersed fine material coats the aggregate or settles and becomes concentrated in the void spaces in the aggregate just above the foundation thus precluding proper intrusion and bond. Care must, therefore, be exercised to ensure that all loose, fine material is removed insofar as possible before placement of aggregate is allowed to commence.

*g. Pumping.* Pumping of grout should be continuous insofar as practical; however, minor stoppages are permissible and ordinarily will not present any difficulties when proper precautions are taken to avoid plugging of grout lines. The rate of pumping should be regulated by use of sounding wells so that the preplaced aggregate is slowly intruded to allow complete and uniform filling of all voids. The rate of grout rise within the aggregate should be controlled to eliminate cascading of grout and to avoid form pressures greater than those for which the forms were designed. For a particular application, the grout injection rate will depend on form configuration, aggregate grading, and grout fluidity.

*h. Joint construction.* A cold joint is formed in PA concrete when pumping is stopped for longer than the time it takes for the grout to harden. When delays in grouting occur, the insert pipes should be pulled just above the grout surface before the grout stiffens, and then rodded clear. When pumping is ready to resume, the pipes should be worked back to near contact with the hardened grout surface and then pumping resumed slowly for a few minutes. Construction joints are formed in a similar manner by stopping grout rise approximately 12 in. below the aggregate surface. Care must be taken to prevent dirt and debris from collecting on the aggregate surface or filtering down to the grout surface. If construction joints are made by bringing the grout to the surface of the coarse aggregate, the joint surfaces should be cleaned and prepared as discussed in paragraph 7-6 d of this manual.

*i. Grouting procedure.* The two patterns for grout injection are the horizontal layer and the advancing slope. Regardless of the system used, grouting should start from the lowest point in the form.

(1) Horizontal layer. In this method grout is injected through an insert pipe to raise the grout until it flows from the next insert hole 3 to 4 ft above the point of injection. Grout is then injected into the next horizontally adjacent hole, 4 or 5 ft away, and the procedure is repeated sequentially around the member until a layer of coarse aggregate is grouted. Successive layers of aggregate are grouted until all aggregate in the form has been grouted.

(2) Advancing slope. The horizontal layer method is not practical for construction of such slabs when the horizontal dimensions are large. In situations such as this, it becomes necessary to use an advancing slope method of injecting grout. In this method, intrusion is started at one end of the form and pumping continued until the grout emerges on the top of the aggregate for the full width of the form and assumes a slope which is advanced and maintained by pumping through successive rows of intrusion pipes until the entire mass is grouted. In advancing the slope, the pumping pattern is started first in the row of holes nearest the toe of the slope and continued row by row up the slope (opposite to the direction of advance of slope) to the last row of pipes where grouting has not been completed. This process is repeated, moving ahead one row of pipes at a time as intrusion is completed.

(3) Grout insert pipes and sounding devices. The number required and the location and arrangement of grout insert pipes will depend on the size and shape of the work being constructed. For most work, grout insert pipes will consist of pipes arranged vertically and at various inclinations to suit the configurations of the work. The guide specification provides for the option of the diameter of the grout insert pipes being either 3/4, 1, or 1-1/2 in. Generally, either a diameter of 3/4 or 1 in. would be allowed for structural concrete having a maximum size aggregate of 37.5 mm (1-1/2 in.) or less. If the preplaced aggregate has a maximum size larger than 37.5 mm (1-1/2 in.), the grout insert pipes should be 1-1/2 in. in diameter. Intrusion points should be spaced about 6 ft apart; however, spacing wider than 6 ft may be permissible under some circumstances, and spacings closer than 6 ft will be necessary in some situations. Normally, one sounding device should be provided for each four intrusion points; however, fewer sounding devices may be permissible under some circumstances. In any event, there should be enough sounding devices, and they should be arranged so that the level of the grout at all locations can be accurately

determined at all times during construction. Accurate knowledge of the grout level is essential to:

(a) Check the rate of intrusion.

(b) Avoid getting the grout too close to the level of the top of the aggregate when placement of the aggregate and intrusion are progressing simultaneously.

(c) Avoid damage to the work which would occur if a plugged intrusion line were washed out while the end of the line was within the grout zone.

Sounding devices usually consist of wells (slotted pipes) through which the level of the grout may be readily and accurately determined. If sounding devices other than wells are proposed, approval should be based on conclusive demonstration that such devices will readily and accurately indicate the level of the grout at all times. In repairing vertical surfaces, such as lock chamber walls or sloping surfaces which are substantial distances and are relatively thin (up to about 2 ft thick), the grout is brought up uniformly from the bottom. Intrusion points for such work should be arranged in horizontal rows with the rows spaced not more than 4 ft apart horizontally. Holes in adjacent horizontal rows should be staggered so that a hole in any row is at the midpoint of the space between holes in the adjacent rows above and below. Intrusion is controlled by pumping through all holes in each horizontal row until grout flows from all holes in the row above. Grouting then proceeds through the next row above after the holes below, which have just been grouted are plugged. The process is repeated until a section is completed. The bottom row of holes should be placed at the bottom of the form.

*j. Finishing unformed surfaces.* If a screeded or troweled finish is required, the grout should be brought up to flood the aggregate surface and any diluted grout should be removed. A thin layer of pea gravel or 3/8- to 1/2-inch crushed stone should then be worked into the surface by raking and tamping. After the surface has stiffened sufficiently, it may be finished as required. A finished surface may also be obtained on PA concrete by adding a bonded layer of conventional concrete of the prescribed thickness to the PA concrete surface. The PA concrete surface should be cleaned and grouted prior to receiving the topping.

### 10-3. Underwater Concrete

*a. General.* For underwater concrete placements to be successful, careful planning and execution are essential. The location and size of the area to be concreted should be

1 Feb 94

well defined and thoroughly cleaned so that it is free of mud, silt, and debris. The extent of the cleaning effort will be determined largely by whether the concrete is being placed into a new structure or being used to repair an existing structure. All marine growth, sediment, debris, and deteriorated concrete must be removed prior to placing new concrete. Waterjets and self-propelled vehicles have been effective in most cleaning applications. Airlifts should be used to remove sediment and debris from depths of 25 to 75 ft. If the concrete is being used to repair an existing structure, an appropriate number of anchors should be grouted into the existing concrete to tie the new concrete to the existing concrete. The concrete must be protected from the water until it is in place so that the cement fines cannot wash away from the aggregate. This protection can be achieved through the proper use of placing equipment, such as tremies and pumps. The velocity of the water immediately adjacent to the placement should not exceed 5 ft/sec. The quality of the in-place concrete can be enhanced by the addition of an AWA which increases the cohesiveness of the concrete. Concrete mixtures to be placed underwater must be highly workable and cohesive. The degree of workability and cohesiveness can vary somewhat depending upon the type of placing equipment used and the physical dimensions of the area to be filled with concrete. A dense, homogeneous mass of concrete having hardened properties equivalent to those of concrete placed in the dry should be the result of a good underwater concrete operation.

*b. Tremie concrete.* A massive and confined placement, such as a cofferdam or a bridge pier, could be completed with a conventional tremie concrete mixture. The desired workability can normally be produced by using 19.0- or 37.5-mm (3/4- or 1-1/2-in.) NMSA and a w/c not exceeding 0.45. An increase in fine aggregate content of approximately 6 percent, as compared to a conventional concrete mixture, may be necessary. Rounded aggregates are preferred over crushed aggregates for both coarse and fine sizes. Listed below is a typical mixture for a conventional tremie mixture:

Portland cement	600 lb/cu yd
Fly ash	100 lb/cu yd
19.0-mm (3/4-in.) NMS natural gravel	
Natural sand	
Sand-aggregate ratio = 0.45	
w/c = 0.45	
AWA	
Air content = 6 %	
Slump = 6 to 8 in.	

Mixtures of this type must be fully protected from exposure to water until in place. Whether being placed by tremie or pump, it is mandatory that the seal be maintained. Once concreting is underway, the bottom of the pipe should be kept buried in the concrete about 5 ft below the surface of the concrete. AWA's can be used in these mixtures but are not necessary, although their use should enhance the fresh properties of the concrete. Spacing of tremie pipes should not exceed 15 ft. A more complete discussion of tremie concreting practices is given in ACI 304R.

*c. Pumped concrete for use underwater.* Many repair situations require that the concrete flow laterally in thin lifts for a substantial distance. This exposes the concrete to much water while being placed. For this type of placement, an AWA should be used to enhance the cohesiveness of the concrete. The cohesiveness and flowability required cannot normally be obtained without use of an AWA. Water-reducing or HRWRA's are usually necessary as well. Trial batches must be made to ensure compatibility between AWA's, WRA's, and HRWR'As. The desired workability can normally be produced with rounded aggregates of 19.0-mm (3/4-in.) NMS or smaller and a w/c not exceeding 0.45. An increase of approximately 6 percent in fine aggregate content, as compared to a conventional concrete mixture, may be necessary. When a repaired area will be subjected to abrasion-erosion, silica fume should be considered to enhance the hardened properties of the concrete. Silica fume will also increase the cohesiveness of the fresh concrete mixture. Listed below is a typical mixture for proportioning an underwater concrete mixture for use in repairing an existing structure:

Portland cement	600 lb/cu yd
Fly ash	30 lb/cu yd
Silica fume	40 lb/cu yd
19.0-mm (3/4-in.) NMS or smaller natural gravel	
Natural sand	
Sand-aggregate ratio = 0.45	
w/c = 0.40	
AWA	
WRA or HRWRA	
Air content = 6 %	
Slump = 8 to 10 in.	

Pumping is the preferred method of placement, although tremies may be used on some repair jobs. Pumping distances should be kept to a minimum. If the pumping distance exceeds 250 ft, pumping pressures will likely increase significantly due to the increased cohesiveness imparted by the AWA. Excessive pumping pressures will

necessitate relocating the pump, using staged pumps to shorten the pumping distance, or modifying the concrete mixture or reducing the amount of AWA's. Some adjustments may reduce the cohesiveness of the concrete, making it more susceptible to washout. If the pumping distance is 150 ft or less, the cohesiveness imparted by an AWA actually improves the pumpability of concrete. When AWA's are used, it is not as critical to keep the discharge end of the tremie or the pump line embedded in the concrete as it is when they are not used. However, the concrete should not be unnecessarily exposed to water during placement. Once in place, concretes of this type can flow up to 30 ft without harmful washout or segregation. Pumped concrete is discussed in detail in paragraph 10-6 of this manual. Additional information on pumped concrete for use under water is given in WES Technical Report REMR-CS-18 (Neeley 1988) and EM 1110-2-2002, "Evaluation and Repair of Concrete Structures."

#### 10-4. Blockout Concrete

*a. General.* The use of blockouts in concrete members is often necessary to embed seats, guides, rails, piping, and electrical and mechanical systems into concrete placements. Prior to placement of blockout concrete, the blockout or recess should be carefully inspected to assure all surfaces are thoroughly cleaned of all loose material, oil, grease, and other material which might reduce or destroy bond between surfaces of the blockout or recess and the new concrete. Care should also be exercised in assuring that blockout concrete is properly consolidated, particularly in those blockouts or recesses which are heavily congested with a combination of embedments and reinforcing steel.

*b. Blockout concrete proportions.* Blockout concrete is normally proportioned to meet the same strength criteria as adjacent concrete. The NMSA is usually 19.0 mm (3/4 in.). Bonding of the blockout concrete to the adjacent formed concrete surfaces is most important. These surfaces must be cleaned of any laitance and any oil, grease, or foreign matter. Cleanup of these surfaces should be the same as for any other surface to which concrete is to be bonded, although sandblasting or high-pressure water jet blasting is not usually necessary for block outs on vertical surfaces. The fluidifying-expanding agent should be used in such proportion that the paste portion of the blockout concrete, when tested separately, will have an expansion of 2 to 4 percent when tested in accordance with ASTM C 940. An expansive admixture conforming to ASTM C 937 (CRD-C 619) should be specified for all vertical blockouts and any other blockouts which are formed or otherwise confined on all sides. Where the blockout is on a horizontal surface and the top of the blockout concrete is to be hand

finished, the expansive admixture should not be used. An epoxy bonding compound meeting ASTM C 881, Type V (CRD-C 595), has been successfully used for bonding of blockout concrete to adjacent concrete although timing can be critical. The new concrete must be placed while the epoxy is still tacky and before it hardens.

#### 10-5. High-Strength Concrete

*a. General.* High-strength concrete has seen increasing use in recent years as compressive strength requirements have increased and new applications have been developed. Early applications emphasized its use to reduce column dimensions. It has now been used to meet special project objectives such as in large composite columns, stiffer structures, bridges, stilling basins, and structures subject to chemical attack. The increased use of high-strength concrete has, in turn, prompted the application of more stringent quality control requirements. A thorough discussion of high-strength concrete is given in ACI 363R.

*b. Definition.* The definition of high-strength concrete is concrete having a 28-day design compressive strength over 6,000 psi (41 MPa) (ACI 116R). In regions where concretes having strengths up to 5,000 psi are readily available, 9,000 psi might be considered to be high-strength concrete. However, in regions where concrete having a compressive strength of 9,000 psi is readily available, 12,000 psi might be considered to be high-strength concrete. In many instances, the required compressive strength is specified at 56- or 90-days age rather than 28-days age to take better advantage of pozzolans in the concrete.

*c. Materials.* When high-strength concrete is to be used, all materials must be carefully selected. Items to be considered in selecting materials include cement characteristics, aggregate size, strength, shape, and texture, and the effects of chemical admixtures and pozzolans. High-strength concretes are typically proportioned with high cement contents, low w/c, normal weight aggregate, chemical admixtures, and pozzolans. Trial mixtures are essential to ensure that required concrete properties will be obtained.

*d. Cement type.* The choice of portland cement is very important. Type I cement is appropriate for use in most high-strength concrete. If high initial strength is required, such as in prestressed concrete, Type III cement may be more appropriate. However, the high cement contents associated with high-strength concretes will cause a high temperature rise within the concrete. If the heat evolution is expected to be a problem, a Type II moderate-heat-of-hydration cement can be used, provided it meets the

strength-producing requirements. However, even within a given type of cement, such as Type I, II, or III, different brands can have different strength development characteristics because of the variations in their physical and chemical compositions.

*e. Cement content.* Cement contents typically range from 660 to 940 lb/yd<sup>3</sup>. However, higher strengths do not always accompany higher cement contents. The concrete strength for any given cement content will vary with the water demand of the mixture and the strength-producing characteristics of the cement being used. The optimum cement content will depend upon the combinations of all materials being used and is best determined by trial batches.

*f. Aggregates.* The choice of aggregates is very important to the ultimate strength that a high-strength concrete will develop since they occupy the largest volume of any of the constituents in the concrete. Most high-strength concrete has been produced using normal weight aggregates. Some high-strength lightweight aggregates and heavyweight aggregates have also been used successfully in high-strength concretes. In general, crushed coarse aggregates, 19.0-mm (3/4-in.) nominal maximum size or smaller, are preferred for high-strength concretes because their shape and surface texture enable the cement paste to bond to them better than rounded natural aggregates. Smaller size aggregates have better bond strengths and less severe stress concentrations around the particles. The ideal aggregate should be clean, cubical, angular, 100-percent crushed aggregate with a minimum of flat and elongated particles. The volume of coarse aggregate can usually be increased up to 4 percent from that recommended in ACI 211.1 for conventional concretes. Natural fine aggregates are preferred because they require less mixing water and provide better workability. Since the concrete has a high cement content, sands having a high fineness modulus (about 3.0) usually give better workability and strength. Sands having fineness moduli of 2.5 and below usually increase the water demand and give the concrete a sticky consistency, making it more difficult to place.

*g. Pozzolans.* Pozzolans in quantities ranging from 15 to 40 percent by mass of cement are frequently used to supplement the portland cement in high-strength concrete. Silica fume is generally used in amounts ranging from 5 to 10 percent by mass of cement. The volume increase in cementitious materials resulting from the addition of a pozzolan is usually offset largely by a decrease in the fine aggregate content. Depending on the type of pozzolan used, the water demand of the concrete mixture may be increased or decreased. When silica fume is used, the water demand will be increased and make the use of an HRWRA

necessary. See paragraph 10-10 of this manual for more information on silica-fume concrete.

*h. Use of HRWRA.* HRWRA's are frequently used in high-strength concrete to lower the w/c. They can also be used to increase the workability of the concrete. In some cases, an HRWRA may be used in combination with a conventional WRA or a retarding admixture to reduce slump loss. Depending on the specified w/c, the required workability, and the materials being used, a conventional WRA used at a high dosage may provide the necessary water reduction. Larger-than-normal dosages of air-entraining admixtures are usually required to entrain air in high-strength concretes due to the high cement contents.

*i. Workability.* Due to their cohesiveness, high-strength concretes can be more difficult to place than conventional concretes. The mixture should be easy to vibrate and mobile enough to pass through closely spaced reinforcement. A slump of about 4 in. will usually provide the required workability. However, all structural details should be considered prior to specifying the fresh properties of the concrete mixtures. Also, the rapid slump loss exhibited by many high-strength concretes should be considered. Slumps of less than 3 in. have been difficult to place without special equipment and procedures.

*j. Proportioning.* More laboratory trial batches may be necessary to properly proportion a high-strength concrete mixture than would be required to proportion a conventional concrete mixture. Once a mixture has been proportioned in the laboratory, field testing with production-size batches is recommended. Frequently, the strength level that can be reasonably achieved in the field will be lower than that attained in the laboratory batches. The water demand may also vary from that determined in the laboratory. Production and quality control procedures can be evaluated more effectively when production-size batches are produced using the equipment and personnel that will be doing the actual work.

*k. Material handling.* The control, handling, and storage of materials need not be significantly different from the procedures used for conventional concrete. However, some emphasis on critical points is prudent. The temperature of all ingredients should be kept as low as possible prior to batching. It may be necessary to make provisions to lower the initial temperature of the concrete by using chilled water, ice, or liquid nitrogen. Delivery time should be reduced to a minimum and special attention given to scheduling and placing to avoid having trucks waiting to unload. Where possible, the batching facilities should be located at or near the job site to reduce haul time. Extended

haul times can result in a significant increase in temperature and loss of slump and should be avoided.

*l. Preparation for placing.* Preparation for placing high-strength concrete should include recognition that certain unusual conditions will exist before any placement begins. Since the effective working time of the concrete is expected to be reduced, preparation must be made to transport, place, consolidate, and finish the concrete as quickly as possible. Proper planning, skilled workmen, adequate equipment, and stand-by equipment are all essential to a successful high-strength concrete placement.

*m. Curing.* Proper curing is critical to the production of high-strength concrete. The potential strength and durability of any concrete, especially high-strength concrete, will be fully developed only if it is properly cured for an adequate period prior to being placed in service. Water curing of high-strength concrete, especially at early ages, is required because of the low w/c's. If the w/c is below 0.40, the degree of hydration will be significantly reduced if free water is not provided during curing. Water curing will allow maximum hydration of the cement.

*n. Testing.* Since much of the interest in high-strength concrete is limited primarily to compressive strength, these measurements are of primary concern in the testing of high-strength concretes. Careful attention should be given to all details of the test methods being used while fabricating, curing, and testing compressive strength specimens. Standard specimens are 6-in.-diameter by 12-in.-high cylinders; however, 4-in.-diameter by 8-in.-high cylindrical specimens have also been used to determine the compressive strength of high-strength concretes. The 4-in.-diameter by 8-in.-high specimens usually exhibit somewhat higher compressive strengths and more variability than the standard size specimens. Even so, proper testing procedures and a suitably accurate and stiff testing machine are more critical to attaining good results than is the specimen size. High-strength sulfur mortar may be used to cap specimens having compressive strengths up to 10,000 psi. Specimens expected to have compressive strengths above 10,000 psi should have their ends formed or ground to the required tolerance. A caution should be added that these higher-strength concretes require a corresponding larger capacity compression testing machine.

## 10-6. Pumped Concrete

*a. General.* Pumped concrete can be used for most structural concrete construction but is most useful where space for construction equipment is limited or access is difficult. Concrete pumps can be either truck- or trailer-

mounted and range from small units, exerting pressures from 250 to 300 psi and outputs of 15 to 30 yd<sup>3</sup>/hr, to large units, exerting pressures of 1,000 psi and outputs up to 150 yd<sup>3</sup>. The effective capacity of a pump depends not only on the pump itself but also on the complete system. Several factors including line length, number of bends in the line, type of line, size of line, height to which the concrete is being pumped, and the concrete mixture affect the effective working capacity of a concrete pump. An excellent reference is ACI 304.2R.

*b. Pump lines.* Pump lines are usually a combination of rigid pipe and heavy-duty flexible hose. Acceptable rigid pipe can be made of steel or plastic and is available in sizes from 3 to 8 in. in diameter. Aluminum alloy pipe should not be used as pump line. Flexible hose is made of rubber, spiral wound flexible metal, and plastics. It is useful in curves, difficult placement areas, and as connections to moving cranes but exhibits greater line resistance to the movement of concrete than rigid pipe and may have a tendency to kink. To obtain the least line resistance, the pipeline should be made up primarily of rigid pipe with flexible hose only where necessary. If possible, the pipeline should be of one size and laid out so as to contain a minimum number of bends.

*c. Mixture proportions.* Concrete mixture proportions of pumpable mixtures are essentially the same as those to be placed by other methods, except that more emphasis should be placed on the grading of the fine aggregates. Concretes which are pumped must be cohesive. Harsh mixtures do not pump well. Pressure exerted by the pump can force the mortar away from the coarse aggregate causing a blockage in the line if the mixture is not proportioned properly. The cement content will generally be somewhat higher for pumped mixtures than those of mixtures placed by conventional methods. The higher fine aggregate content will have a higher water demand, which in turn will require a higher cement content. However, extra cement should not be used to correct pumping deficiencies resulting from poorly graded aggregates. It is usually more preferable to correct deficiencies in the fine aggregates by blending in additional fine aggregates or pozzolan than by adding cement.

*d. Coarse aggregates.* The nominal maximum size of the coarse aggregate is limited to one-third of the smallest inside diameter of the pump line for crushed aggregates or 40 percent of the smallest inside diameter of the pump line for well-rounded aggregates. Oversize particles should be eliminated. A higher mortar content will be necessary to effectively pump a concrete containing crushed aggregates than for a concrete containing rounded aggregates.



Depending upon the type and size of the coarse aggregate, it may be necessary to reduce the coarse aggregate content from 5 to 10 percent as compared to mixtures placed by conventional methods.

*e. Fine aggregate.* The properties of fine aggregates are more critical in proportioning pumpable mixtures than are the properties of the coarse aggregates. Together with the cement and water, the fine aggregates constitute the mortar which conveys the coarse aggregates in suspension through the pump line. Fine aggregates should conform to the requirements given in ASTM C 33 (CRD-C 133) for fine aggregates. In addition, for pump systems having lines 6-in. in diameter and smaller, 15 to 30 percent of fine aggregate should pass the 300- $\mu\text{m}$  (No. 50) sieve and 5 to 10 percent should pass the 150- $\mu\text{m}$  (No. 100) sieve. Fine aggregates that are deficient in either of these two sizes should be blended with selected finer aggregates to produce the desired grading. Pumpability of concrete is generally improved with a decrease in the fineness modulus. Fine aggregates having a fineness modulus between 2.40 and 3.00 are generally satisfactory provided that the percentages passing the 300- and 150- $\mu\text{m}$  (No. 50 and No. 100) sieves meet the previously stated guidelines. Fineness modulus values alone without stipulations on the finer sizes may not produce satisfactory results. Both manufactured fine aggregates and natural sands can be used in pumped mixtures provided their gradings are appropriate; however, natural sands are preferred due to their rounded shape.

*f. Slump.* The water requirements to establish the optimum slump and to maintain control of that slump throughout the course of a pumping placement are both extremely important factors. Concretes having slumps less than 2 in. when delivered to the pump are difficult to pump. Concretes having slumps over 6 in. can segregate causing a blockage in the pump line and may require a pump aid to increase the cohesiveness of the concrete to prevent the aggregate from separating from the mortar during pumping. It is much more important to obtain a cohesive concrete through proper proportioning than to try to overcome deficiencies by adding extra water. In fact, the use of excess water creates more problems than it solves.

*g. Admixtures.* Materials which improve workability, such as water-reducing, high-range water-reducing, and air-entraining admixtures, as well as pozzolans, usually improve pumpability. It is common to experience a decrease in air content during pumping. The specified air contents required for durability should be obtained at the point of placement in the structure. Therefore, it may be necessary to entrain a higher air content into the concrete mixture prior to pumping. Pumping aids are admixtures which can reduce

friction, reduce bleeding, and increase cohesiveness, all of which make concretes pump easier.

*h. Pumpability tests.* There is no standard laboratory test method available to accurately test the pumpability of a concrete mixture. Testing a concrete mixture for pumpability involves duplicating anticipated job conditions from beginning to end. A full-scale field test for pumpability should be considered to evaluate both the mixture proportions and pumping equipment. Prior use of a mixture and pumping equipment on another job may furnish evidence of pumpability if job conditions are duplicated.

*i. Planning.* Proper planning of the entire pumping operation including pump location, line layout, placing sequence, and concrete supply will result in savings of time and expense. The pump should be as near the placement area as possible. Concrete delivery systems should have easy access to the pump. Lines from the pump to the placement area should be made up primarily of rigid pipe and contain a minimum number of bends. For large placement areas, alternate lines should be laid for rapid connection when required, and standby power and pumping equipment should be readily available to replace an initial piece of equipment should a breakdown occur.

*j. Other requirements.* When pumping downward 50 ft or more, an air release valve at the middle of the top bend will prevent vacuum or air buildup. When pumping upward, a shutoff valve near the pump will prevent the reverse flow of concrete during the fitting of cleanup equipment or when working on the pump. Direct communication should be maintained between the placing crew and the pump operator. Good communication between the pump operator and the concrete batch plant is also important. It is desirable to have the concrete delivery such that the pumping can proceed continuously. When a delay occurs, it may be difficult to start the concrete moving in the line again, especially if the delay has been for a considerable length of time. This critical delay time will depend upon such factors as the concrete mixture, temperature, length of pipeline, and type of pump. It may be necessary to clean the line and start again if the delay becomes extended. A grout or mortar should be used to lubricate the pipeline anytime pumping is started with clean lines, but it should not be pumped into the forms.

*k. Quality verification.* A high level of quality control must be maintained to provide assurance that the concrete is of the desired quality. Concrete should be sampled at both ends of the pumpline to determine what, if any, changes in the slump, air content, and other concrete

properties occur during pumping. However, the quality of the concrete being placed in the structure can only be measured at the placement end of the pumpline.

## 10-7. Fiber-Reinforced Concrete

*a. General.* Fiber-reinforced concrete (FRC) is concrete which contains dispersed, randomly oriented fibers. Fiber-reinforced concrete and fiber-reinforced shotcrete have been used for pavements, overlays, patching, floor slabs, refractory materials, hydraulic structures, thin shells, armor for jetties, rock slope stabilization, tunnel linings, and precast units since the mid 1960's. Fibers have been produced from steel, plastic, glass, and natural materials in various shapes and sizes. ASTM A 820 (CRD-C 539) is the specification which covers minimum standards for steel fibers intended for use in fiber-reinforced concrete. The size of fibers are usually described by their aspect ratio, which is the fiber length divided by an equivalent fiber diameter. Aspect ratios typically range from about 30 to 150. Some steel fibers are collated with water-soluble glue into bundles of 10 to 30 fibers to facilitate handling and mixing. Uniform dispersion of fibers through the concrete provides isotropic strength properties not common to conventionally reinforced concrete. Additional information on steel FRC may be found in ACI 544.1R, ACI 544.2R, ACI 544.3R, and ACI 544.4R.

*b. Advantages and limitations.* Steel fibers increase the first crack flexural strength, direct tensile strength, and splitting tensile strength. Compressive strengths may exhibit a minor increase. Fibers can increase the ductility of concrete substantially depending on the type and amount of fiber present in the concrete. However, balling of fibers in the mixer hinders uniform distribution and reduces workability. This can impose an upper limit beyond which benefits gained from the fibers are no longer realized. This upper limit depends upon the type and size of fibers and the mixing procedures being used. Because of mixing and placing considerations, approximately 2 percent by volume of the total concrete mixture is considered the practical upper limit for most types of fibers in field placements. Higher percentages could be used when the fibers are a type that do not interlock significantly. However, fibers with hooked ends can achieve essentially the same properties as straight fibers of the same aspect ratio using less fiber.

*c. Toughness.* Steel fibers increase the toughness, which is a measure of the energy absorption capacity of concrete. The increase in toughness depends on the type, amount, and aspect ratio of the fibers. In general, crimped fibers, surface-deformed fibers, and fibers with hooked ends

produce toughness indexes greater than those for smooth straight fibers at the same volume concentration.

*d. Performance characteristics.* Steel fiber concrete has shown good resistance to dynamic forces and a significant increase in fatigue strength. Fatigue strength tends to increase with an increase in fiber loading, and the crack width under fatigue loading tends to decrease. The benefits that a conventional concrete mixture gains from steel fibers depend primarily on the loading of fibers and the size, shape, and aspect ratio of the fibers. Steel-fiber concrete has not shown excessive corrosion of the steel fibers when placed in corrosive environments. The corrosion has been confined to the fibers actually exposed to the surface. Fiber-reinforced concrete has shown good resistance to cavitation forces resulting from high-velocity water flow and to the damage caused by the impact of large waterborne debris at high velocity. However, FRC exhibits poor resistance to abrasion that occurs from the grinding action of rocks and debris carried in low-velocity water. Therefore, FRC shall not be used in areas subject to underwater abrasion.

*e. Mixture proportioning.* Fiber-reinforced concrete generally has higher cement and fine aggregate contents and smaller NMSA than conventional concrete. Coarse aggregates are generally 19.0-mm (3/4-in.) nominal maximum size or smaller. Pozzolans are often used to reduce the relatively high cement contents. Chemical admixtures are commonly used for air-entrainment, water reduction, and workability improvement. To ensure uniform mixing, the maximum aspect ratio of round wire and flat strip fibers should be no greater than 100. Characteristically, an FRC mixture will experience a decrease in workability as the fiber loading increases. Experience suggests w/c between 0.40 and 0.60 and cementitious contents between 500 and 900 lb/yd<sup>3</sup> are required when steel fibers are used to produce adequate paste to coat the large surface area of the fibers. The percentage of fine aggregate to total aggregate will range from 45 to 60 percent depending on the NMSA and aggregate gradings. Once mixture proportions have been developed, a full-size trial batch should be produced in the plant and mixer to be used for the project prior to the actual placement of the fiber-reinforced concrete.

*f. Batching and mixing.* Mixing of FRC can be accomplished by different methods, depending on the job requirements and the facilities that are available. The ultimate goal is to have a uniform dispersion of the fibers and prevent the segregation or balling of the fibers during mixing. Segregation or balling of the fibers is related to

several factors, the most important of which appears to be the aspect ratio. Other factors such as the fiber loading, coarse aggregate size, aggregate grading, w/c ratio, and method of mixing can also influence the fiber distribution. Increases in aspect ratio, fiber loading, coarse aggregate size, and quantity of coarse aggregate intensify balling tendencies. Most fiber balling occurs as the fibers are added to the concrete mixture and can be eliminated by controlling the rate of fiber addition or by the use of collated fibers. If collated fibers are used, they may be dumped directly into the concrete mixture as the last step. Subsequent mixing action separates and disperses the fibers throughout the mixture. If loose fibers are used, they must be added slowly and uniformly to the mixture in such a way as to prevent large clumps of fibers from entering the mixture. The fibers can be added to the aggregates prior to introduction of the cement and water or as the last step. The method of introducing the fiber into the mixture should be tried in the field during a trial mixture. Fiber balling that occurs after fiber addition can usually be attributed to overmixing or poor mixture proportions, such as too much coarse aggregate or a fiber loading that is too high.

*g. Placement.* A fiber-reinforced concrete mixture will generally require more effort to move and consolidate into forms. The fibrous nature of the mixture makes the use of shovels or hoes difficult. Forks and rakes are preferred for handling low-slump mixtures. Properly controlled internal vibration is acceptable, but external vibration of the forms and exposed surface is preferable to prevent fiber segregation. Standard finishing and curing methods can be used with FRC with one exception. If a textured surface is desired, a burlap drag is not recommended as the fibers can hang up in the burlap. A textured surface can be obtained by brooming with a stiff brush, but it should be delayed as long as possible to prevent pulling fibers to the surface.

*h. Workability.* The inverted slump cone test, described in ASTM C 995 (CRD-C 67), should be used as an indicator of workability of FRC. The advantage of the inverted slump cone test over the slump test is that it takes into account the mobility of concrete which comes about because of vibration. Reliance on the slump test often results in the use of excessive amounts of water in an attempt to increase the slump without improving workability.

*i. Pumping.* Fiber-reinforced concrete with fiber loadings up to 1.5 percent by volume of the total mixture have been pumped using 5- to 6-in.-diam pipelines. Steel FRC can be produced using conventional shotcrete equipment.

*j. Other fibers.* Glass fibers are subject to chemical attack by the alkalinity of the concrete, become brittle, and lose their effectiveness over a period of time. Nylon, polypropylene, and polyethylene fibers are not subject to chemical attack. Polypropylene fibers are available in several forms, such as smooth monofilaments, fibrillated monofilaments, fibrillated mesh, and collated fibrillated mesh. Properties of polypropylene FRC can vary somewhat depending upon the type of fiber used. Incorporation of polypropylene fibers into concrete can result in a small improvement in flexural and tensile strengths; however, these improvements are not always evident. Compressive strengths can be either increased or decreased. Fracture toughness can be increased, and shrinkage can be decreased.

*k. Effects of polypropylene fibers on workability.* Polypropylene fibers also affect the rheological properties of fresh concrete. Slump decreases as the volume concentration of fibers increases. The slump of a typical concrete can decrease by as much as 50 percent with the addition of 0.10 percent polypropylene fibers. Bleeding can be significantly reduced in polypropylene FRC.

*l. Use of polypropylene fibers.* Polypropylene FRC is typically used in nonload-bearing applications particularly where impact resistance is important. The use of polypropylene fibers for control of cracking in slabs is still being debated due to the amount of fibers required to positively affect the amount of cracking and the subsequent effect on workability.

## 10-8. Porous Concrete

*a. General.* Porous concrete is commonly used where either free drainage is required or where lower mass and lower thermal conductivity are required. The use of lightweight aggregates is not practicable or desired. It is normally produced by binding a gap-graded or a single-size aggregate with a cement paste. The structure of the material permits the passage of water but also provides moderate structural strength. Porous concrete has been used for drain tiles, drains beneath hydraulic structures to relieve uplift pressures, pavement edge drains, etc.

*b. Types.* At least three distinct types of porous concretes can be produced. These include cellular concretes made by introducing a preformed foam into the fresh mortar or causing the creation of gas bubbles in the mortar due to a chemical reaction; lightweight aggregate concrete made with natural or synthetic aggregates which are often extremely porous; or concrete which uses gap-graded or

single-size aggregate and typically totally eliminates the fine aggregate fraction from the mixture (no-fines concrete). While each of these concretes are porous, they possess differing void structures. Cellular and lightweight aggregate concretes may contain large percentages of voids, but these voids are relatively noncommunicating. Porous concretes produced by intentional gap grading or without fine aggregate can result in concrete with high percentages of interconnected voids. The porous concretes with noncommunicating voids may absorb small amounts of moisture, but they do not allow rapid passage of water through the concrete. For this reason cellular and lightweight concretes should not normally be considered for the porous concrete applications previously noted and are not discussed in further detail.

*c. Composition.* Porous concrete is composed of coarse aggregate, cementitious material, and water. Occasionally, a small amount of fine aggregate can be used to increase the compressive strength and to reduce percolation. The coarse aggregate should comply with ASTM C 33 (CRD-C 133) size designations No. 8 (9.5-mm (3/8-in.) NMSA), No. 7 (12.5-mm (1/2-in.) NMSA), or No. 67 (19.0-mm (3/4-in.) NMSA). Both rounded and crushed aggregates have been used to produce porous concrete.

*d. W/C considerations.* The w/c of a porous concrete mixture is important to achieve the specified strength and to help create the proper void structure. A high w/c reduces the cohesion of the paste to the aggregate and causes the paste to flow downward and blind the void structure when the mixture is even lightly compacted. If the w/c is too low, balling will occur in the mixture, and the materials will not be evenly distributed throughout the batch. Experience indicates that the w/c should fall within a range of 0.35 to 0.45 for the paste to be stable and provide the best aggregate coating. The w/c - compressive strength relationship which is normally associated with conventional concrete does not apply to porous concrete.

*e. Durability.* The frost resistance of porous concrete is acceptable if the bonding paste is air entrained. However, because of the interconnected void system and high surface area of exposed paste in porous concrete, resistance to aggressive attack by sulfates and acids that may percolate through this concrete is questionable.

*f. Percent voids.* The percent voids, expressed as the air content, should be determined in accordance with ASTM C 138 (CRD-C 7). The air content should be 15 percent or greater, by volume, to ensure that water will percolate through porous concrete. The compressive strength of porous concrete will range from approximately 3,500 psi at

28-days age when the air content is 15 percent to approximately 1,500 psi when the air content is 25 percent. The percolation rate is proportional to the air content of porous concrete while the compressive strength is inversely proportional. The compressive strength also increases as the NMSA decreases.

*g. Proportioning porous concrete mixtures.* Although no ACI guidance for proportioning porous concrete currently is available, research conducted by the National Aggregates Association-National Ready Mixed Concrete Association (Meininger 1988) indicates that the dry-rodded unit weight of coarse aggregate as determined by ASTM C 29 (CRD-C 106) can be effectively used to proportion porous concrete. This approach to proportioning uses the  $b/b_0$  concept discussed in CRD-C 99 for proportioning normal weight concrete. The ratio  $b/b_0$  compares the amount of coarse aggregate in a unit volume of concrete with the amount of coarse aggregate in a like volume of dry-rodded coarse aggregate. This method automatically compensates for the effects of different coarse aggregate particle shape, grading, and density. Also, the  $b/b_0$  values for a range of NMSA normally used in porous concrete (9.5 to 19.0 mm (3/8 to 3/4 in.)) are very similar.

*h. Placement.* Proper construction methods are critical to the performance of porous concrete. Some compaction is needed during placement and the coarse aggregate on the top surface needs to be properly seated to reduce ravelling of the surface. Small steel wheel rollers have been used with some success for compaction. Curing is very important since porous concrete can dry very rapidly. Curing is vital to the continued hydration of the top surface. The level of compaction should be considered in the mixture proportioning study. If the porous concrete is compacted too much, the void content may be reduced below 15 percent, and flow channels will be plugged. Too little compaction will cause the concrete to have a very high void content and will result in low strength. Test specimens should be compacted to the same density as will be obtained in the field. This may require some experimentation in the laboratory to obtain comparable compaction in the field and the laboratory.

## 10-9. Flowing Concrete

*a. General.* Flowing concrete is defined by ASTM C 1017 (CRD-C 88) as "concrete that is characterized as having a slump greater than 7-1/2-in. while maintaining a cohesive nature." It can be placed to be self-leveling, yet remaining cohesive without segregation, excessive bleeding, or extended retardation. Flowing concrete can be used in

congested areas where members are reinforced or unusually shaped or in areas of limited access. Flowing concrete pumps easily, and therefore, the concrete pumping distance and rate are increased. Proper consolidation around reinforcement is more easily achieved with flowing concrete than normal-slump concrete, and less vibration is required. Proper vibration is necessary for complete consolidation and bond to reinforcing steel.

*b. HRWRA.* Flowing concrete is produced by the addition of a normal (Type I) or a retarding (Type II) HRWRA, as described by ASTM C 1017 (CRD-C 88). These admixtures are generally identical to those described by ASTM C 494 (CRD-C 87) as HRWRA's, Types F and G, respectively. Flowing concrete cannot be produced by the addition of water since it will lose the cohesiveness necessary to minimize segregation. The amount of HRWRA required to produce flowing concrete varies depending upon the cement type, w/c, initial slump, temperature, time of addition, concrete mixture proportions, and the type of admixture. Concretes having lower initial slumps generally require larger amounts of HRWRA to produce flowing concrete than do concretes having higher initial slumps. HRWRA are also generally more effective in concrete having higher cementitious material contents.

*c. Proportioning flowing concrete.* Mixture proportions for flowing concrete usually contain more fine material than a conventional concrete mixture. This is necessary to achieve a flowable consistency without excessive bleeding or segregation. The fine aggregate content is usually increased by 3 to 5 percent, and in some cases, an increase in cement or pozzolan may be necessary. Since HRWRA's are usually added in large volumes, the water in the admixture must be accounted for in calculating w/c and yield. Higher dosages of air-entraining admixture are usually required to maintain proper air content in flowing concrete. The air content should be monitored regularly at the point of discharge into the forms so that the dosage of air-entraining admixture can be adjusted as necessary to maintain the air content within the specified range. The slump should be measured prior to addition of the HRWRA to assure that an excessive amount of water has not been added to the batch. After the HRWRA is added and thoroughly mixed into the concrete, the resulting slump should be within the specified range.

*d. Flowing concrete fresh properties.* Flowing concretes may exhibit a rapid slump loss depending on a variety of factors. Concrete temperature, cement composition, and cement content will influence the rate of slump loss. Also, flowing concrete made with plasticizing admixtures can lose much of its slump in as few as

30 minutes. Plasticizing admixtures must be measured accurately and discharged onto the concrete properly regardless of where their addition occurs. Additional dosages of HRWRA can be used when delays occur and slump is lost. Up to two additional dosages have been used successfully. In general, the compressive strength is unchanged, but the air content is decreased with additional dosages of HRWRA. The characteristics of flowing concrete at the time of finishing should be similar to that of conventional concrete with the same materials. Properly proportioned flowing concrete should not exhibit objectionable bleeding. As with the finishing of conventional concrete, proper timing of each finishing operation is imperative.

*e. Flowing concrete hardened properties.* The compressive strength, flexural strength, drying shrinkage, creep, and permeability of flowing concrete is not significantly different than that of lower slump concrete having the same w/c and air content. The air-void system may have larger bubble spacing factors and a decrease in the number of voids per inch compared to the initial concrete, yet satisfactory frost resistance is still achieved in most cases.

#### 10-10. Silica-Fume Concrete

*a. General.* The use of silica fume as a pozzolan in concrete produced in the United States has increased in recent years. When properly used, it can enhance certain properties of both fresh and hardened concrete including cohesiveness, strength, and durability. Silica-fume concrete may be appropriate for concrete applications which require very high strength, high abrasion resistance, very low permeability, or where very cohesive mixtures are needed to avoid segregation.

*b. Properties of silica fume.* Silica fume is a by-product of fabrication of silicon or ferrosilicon alloys. It is a very fine powder having a medium to dark gray color. It is available as loose powder, densified powder, slurry, and in some areas as a blended portland-silica-fume cement. Silica-fume particles are spherical and are typically 100 times smaller than portland-cement grains. It typically has an SiO<sub>2</sub> content of 85 to 98 percent. It appears that concretes benefit from both the pozzolanic properties of silica fume as well as from the extremely small particle size. Silica fume is generally proportioned as an addition, by mass, to the cementitious materials and not as a substitution for any of those materials.

*c. Effect on water demand and bleeding.* Silica fume has a great affinity for water because of its high surface

area, and this is reflected in the concrete which contains it. The increased water demand of concrete containing silica fume can be overcome with the use of a WRA or HRWRA and to a lesser extent by reducing the fine aggregate content of the mixture. Silica-fume concrete exhibits less bleeding than conventional concrete because the high affinity of silica fume for water results in very little water left in the mixture for bleeding. Silica-fume particles attach themselves to adjacent cement particles and reduce the available channels for bleeding.

*d. Effect on cohesiveness.* Concrete containing silica fume is more cohesive and less prone to segregation than a comparable mixture without fume; however, it also tends to lose slump more rapidly. Silica-fume additions greater than 10 percent should generally be avoided because the resulting concrete mixture will become "sticky" and require more vibration for proper consolidation. A slump increase of approximately 2 in. may be necessary to overcome this problem and to maintain the same consistency for some length of time. On the other hand, some increase in cohesiveness is an advantage in both flowing and pumped concretes.

*e. Effect on air entrainment.* The dosage of AEA required to produce a particular air content in concrete increases significantly with increasing amounts of silica fume. The amount of AEA needed in silica-fume concrete to entrain a specified amount of air may be as much as five times greater than that required for similar concrete without fume. It may also be difficult to entrain more than 5 percent air in concrete containing high silica-fume contents.

*f. Effect on plastic shrinkage.* When the curing conditions allow a faster rate of evaporation of water from the surface of fresh concrete than the water replaced by bleeding from the concrete underneath, plastic shrinkage cracking will occur. Therefore, all admixtures and pozzolans which reduce bleeding of fresh concrete make it more prone to plastic shrinkage cracking. This is particularly true for silica-fume concrete in which bleeding is significantly reduced. The problem can become very

serious under curing conditions of high temperature and high wind velocity which favor faster evaporation of water from fresh concrete surfaces. A light fog spray of water can be used to keep surfaces from drying between finishing operations, or a sheet material can be used to cover the surface. Moist curing should begin immediately after finishing and should continue for a minimum of 14 days.

*g. Effect on strength and modulus of elasticity.* Strength development characteristics of silica-fume concrete are similar to those of fly ash except that the results of the pozzolanic reactions of silica fume are evident at early ages. This is because silica fume is a very fine material with a very high glass and silica content. However, since silica fume increases the water demand of a mixture, use of a WRA or HRWRA to offset water demand is necessary to take full advantage of silica fume's full potential for increasing strength. The ratio of flexural to compressive strength of silica-fume concrete follows the same pattern as conventional concrete. There are no significant differences between the Young's modulus of elasticity of concrete with and without silica fume. However, very high-strength concretes tend to be more brittle, and this is also true of high-strength silica-fume concrete.

*h. Effect on permeability and durability.* Pozzolans and GGBF slag often significantly reduce the permeability of concrete due to their influence on the fine pore structure and interfacial effects. Silica fume is a much more efficient pozzolanic material than natural pozzolans or fly ash, and therefore, it decreases concrete permeability dramatically. However, silica-fume concrete must still be properly air-entrained if it is subject to critical saturation and repeated cycles of freezing and thawing. Silica-fume concretes have exhibited reduced chloride-ion permeability, enhanced resistance to attack from sulfates and other aggressive chemicals, and enhanced abrasion resistance. While abrasion resistance is more dependent upon the hardness of the aggregate than upon that of the paste, the addition of silica fume can increase the abrasion resistance of concrete when hard aggregates are unavailable or cannot be economically justified, and inferior aggregates must be used.

## Chapter 11 Concrete Report

### 11-1. General

*a. Policy.* A concrete report will be completed at the conclusion of construction on any major concrete structure such as a concrete dam, lock, or any project that is unique or unusual. The specific requirements for concrete report are outlined in ER 1110-2-402, "Concrete Reports." The concrete report will serve the dual purpose of meeting the requirements of ER 1110-2-100, "Periodic Inspection and Continuing Evaluation of Completed Civil Works Structures," for engineering data retained at the project site and advancing the state of the art of constructing large concrete structures by providing personnel working on subsequent projects with a discussion of problems encountered and solutions devised.

*b. Author.* The concrete report should be completed by personnel who are familiar with the project preferably the concrete engineer assigned to the project. Personnel from the engineering division should contribute to the report in any areas where they have special knowledge.

*c. Timing.* The report should be written as the project progresses so that important information is not lost as personnel changes occur. The report should be completed within 120 days of substantial completion of concrete placing.

### 11-2. Content

*a. Outline.* The concrete report should be written to fulfill the objectives of providing information to those who may investigate problems with concrete on the project in the future, those embarking on the design of a similar project, or those periodically inspecting the project. The concrete report should include discussions of problems encountered in each phase of concrete production and placement, including the production of aggregates. The solutions to these problems should be summarized. The typical outline provided in Table 11-1 should serve as a guide in the preparation of the concrete report.

*b. Detailed instruction.* The information to be included in the concrete report are discussed in accordance with the outline listed in Table 11-1.

(1) Introduction. The introduction of the report should state the purpose of the report, its scope, and the authority for the document in accordance with ER 1110-2-402,

"Concrete Reports" In addition, the report should include a project description and a location and vicinity map to serve as a guide independent of other project documents. The introduction should also include a summary table of the quantities of each major type of concrete on the project, i.e. interior mass, exterior mass, structural, tremie, backfill, etc.

(2) Aggregate sources. Each aggregate source used for concrete on the project should be provided by name, coordinates, and/or street or township of the pit or quarry. If test data are available in TM 6-370 (USAEWES 1953), the volume, area, and index numbers should be provided. Drawings or photographs should be provided to indicate the exact location within the pit or quarry from which the aggregate was produced.

#### (3) Aggregate production.

(a) Pit or quarry operation. This section discusses the removal of material from the pit or quarry including the make, model, and capacity of the primary equipment. In case of a quarry, the most commonly used blasting pattern should be detailed to include blast hole spacing and depth, powder types and requirements, and powder factor. Photographs should be used to the maximum extent to show the equipment and operation.

(b) Fine aggregate production. Photographs and a flow chart should be included showing the sequential processing of the fine aggregate. The major equipment used in the fine aggregate production should be listed by make, model, and capacity.

(c) Coarse aggregate production. Photographs and a flow chart should be included showing the sequential processing of the coarse aggregate. The major equipment used should be listed by make, model, and capacity. The particle shape should be discussed. In this regard, closeup photographs of the various stockpiles are most helpful. Readily visible and identifiable objects such as pens, hardhats, or rules should be placed nearby to provide scale. If spray bars or wood pickers are required, this should be noted.

(d) Stockpiling and handling. The number of stockpiles and the sizes of aggregate in each stockpile should be noted. The approximate size of the stockpile during normal aggregate production and concrete placing should be noted. Photographs or drawings are preferred for this purpose. If a stockpile was reduced to a very low level during the placing of concrete, the time of this occurrence should be noted. The equipment used to move aggregate to and from the stockpile should be noted.

---

**Table 11-1**  
**Concrete Report - Typical Outline**

---

1. Introduction.
  - a. Purpose, scope, and authority
  - b. Project description
  - c. Concrete quantities by type
  - d. List of responsible personnel
2. Aggregate sources
  - a. General
  - b. Properties of sources used
3. Aggregate production
  - a. Pit or quarry operation
  - b. Fine aggregate production
  - c. Coarse aggregate production
  - d. Stockpiling and handling
4. Cementitious materials
  - a. Portland cement sources
  - b. Blended hydraulic cement sources
  - c. Pozzolan sources
  - d. GGBF slag
  - e. Silica fume
5. Chemical admixtures
  - a. Air-entraining admixtures
  - b. Water-reducing admixtures
  - c. Retarding admixtures
  - d. Accelerating admixtures
  - e. Others
6. Concrete batching and mixing plant(s)
7. Concrete mixtures used
  - a. Mass concrete
  - b. Structural concrete
  - c. Special concrete (RCC, fiber reinforced)
  - d. Shotcrete
8. Construction joint preparation



**Table 11-1 (Continued)**

---

9. Concrete transportation, placement, and consolidation
    - a. Concrete transportation
    - b. Concrete placement
    - c. Shotcrete placement
    - d. Concrete placing schedule
    - e. Concrete consolidation
  10. Concrete curing and protection
  11. Temperature control
    - a. Insulation
    - b. Precooling
    - c. Postcooling
    - d. Heating
  12. Special concretes
    - a. Fiber-reinforced concrete
    - b. Roller-compacted concrete
    - c. Tremie concrete placed in cutoff walls
    - d. Tremie concrete in underwater applications
    - e. Other unusual applications of material or means of placement
  13. Precast concrete
  14. Quality verification and testing
    - a. Government quality verification
    - b. Laboratory facilities
  15. Summary of test data
    - a. Aggregate quality tests
    - b. Aggregate grading tests
    - c. Tests of cementitious materials
    - d. Tests of admixtures
    - e. Concrete strength tests
    - f. Concrete F/T tests
    - g. Air content tests
    - h. Slump tests
    - i. Placing temperature
    - j. Resistance thermometer data
  16. Special problems
    - a. Problem
    - b. Actions
    - c. Comments
-

1 Feb 94

(4) Cementitious materials.

(a) Portland cement sources. The sources of portland cement used on the project should be noted as well as the dates they were used and the approximate locations of their use. The means of transporting the cement to the project site should be noted and the transfer and storage facilities described.

(b) Blended hydraulic cement sources. If blended hydraulic cement is used on the project, it should be discussed as described for portland cement in the previous paragraph.

(c) Pozzolan source. The sources of pozzolan used on the project should be listed. If commercial sources are used, the location of the firms supplying the pozzolan should be listed. If a source of natural pozzolan is developed and used by the Contractor or if a natural source is opened nearby by a commercial operator to supply pozzolan to the project, the location of the source should be provided and the processing requirements outlined.

(d) GGBF slag or silica fume. The sources of GGBF slag or silica fume, or both, if used, should be listed. Storage, handling, and batching facilities should be described. If they were used only in certain locations in the structures, the locations, dates placed, and mixture proportions should be included.

(5) Chemical admixtures. The brand name, sources, and available test data of all chemical admixtures used on the project should be listed as well as the structure feature in which they were used.

(6) Concrete batching and mixing plant. The concrete batching and mixing plant should be described to include make, model, and capacity of major bins, conveyor belts, hoppers, mixers, and controls. Photographs of the overall plant layout should be included.

(7) Concrete mixtures used. The proportions of the concrete mixtures used during the bulk of the placement of each major class of concrete should be tabulated. The aggregate batch weights should be reported at saturated surface dry. If significant field adjustments were made to the concrete mixtures that were supplied by the division laboratory being placed in a dam, power plant, lock, or other major water control structures, the extent of the adjustment should be noted and reasons for the adjustment discussed. If shotcrete is used on the project, the type of placement (wet or dry) should be noted and the type and capacity of equipment listed.

(8) Equipment and techniques. The equipment and techniques used for joint preparation should be described.

(9) Concrete transportation and placement. The type and capacity of equipment used to transport the concrete from the mixer to the placement site should be described. The means of placement should be described and the number and type of vibrators noted. The normal and maximum rates of placement of each major class of concrete on the project should be listed.

(10) Concrete curing and protection. A brief description should be provided outlining the Contractor's selected means of curing and protecting the concrete. Any mishaps which occurred during curing and protection which may have reduced the level of protection or truncated the curing process on parts of major structures should be noted.

(11) Temperature control. The description of the temperature control measures used on the project will include the types of insulation used, the major components of any required pre- or postcooling systems, the dates that various control measures were used during the construction period, and any mishaps which resulted in deviations from the specified temperature control requirements.

(12) Special concretes. On any project that includes concrete different than the usual cast-in-place mass or structural concrete, a section should be provided detailing the materials used, the method of placement, problems encountered, and how they were solved. Concrete applications which should be discussed include tremie concrete when placed in a major project element such as a cutoff wall, underwater foundation, or fiber-reinforced concrete.

(13) Precast concrete. The type, description, name, and location of the manufacturer of precast units used on the project should be provided.

(14) Quality verification and testing. The procedure and extent of the GQA program and the CQC program should be described. The types and frequencies of the tests and quality verifications performed by the Government should be listed. The facility used by the Government for GQA purposes and by the Contractor for CQC should be described.

(15) Summary of test data. The format for the presentation of data from the various quality assurance tests and quality control tests should be such that long tables of raw data are avoided. Charts should be used where possible. Charts and tables when used should show the

average of the values presented as well as the extremes and the specification limits. Use of computer programs for compiling and analyzing concrete data during construction is encouraged. The reports generated by these computer programs may be incorporated into the concrete report with minimum efforts. It is recommended that complete testing data stored in disks be included as enclosure for future use.

(16) Special problems. Any unusual problems encountered during the concrete construction and corrective actions taken should be described. Any comment or evaluation of the results should be provided or documented.

## Appendix A References

### A-1. Required Publications

**TM 5-822-7**

Standard Practice for Concrete Pavements

**ER 415-1-11**

Biddability, Constructibility, and Operability

**ER 1110-1-261**

Quality Assurance of Laboratory Testing Procedures

**ER 1110-1-2002**

Cement, Pozzolan, and Slag Acceptance Testing

**ER 1110-1-8100**

Laboratory Investigations and Materials Testing

**ER 1110-2-100**

Periodic Inspection and Continuing Evaluation of Completed Civil Works Structures

**ER 1110-2-402**

Concrete Reports

**ER 1110-2-1150**

Engineering and Design for Civil Works Projects

**ER 1110-2-1200**

Plans and Specifications

**ER 1180-1-6**

Construction Quality Management

**EM 1110-1-1804**

Geotechnical Investigations

**EM 1110-2-2002**

Evaluation and Repair of Concrete Structures

**EM 1110-2-2302**

Construction with Large Stone

**EP 415-1-261**

Quality Assurance Representative's Guide

**CW 03101**

Formwork for Concrete

**CW 03150**

Expansion, Contraction, and Construction Joints in Concrete

**CW 03301**

Cast-in-Place Structural Concrete

**CW 03305**

Guide Specification for Mass Concrete

**CW 03307**

Concrete (for Minor Structures)

**CW 03362**

Preplaced Aggregate Concrete

**CW 03425**

Precast-Prestressed Concrete

**US Army Engineer Waterways Experiment Station 1949**

US Army Engineer Waterways Experiment Station. 1949. *Handbook for Concrete and Cement*, with quarterly supplements (all CRD-C designations), Vicksburg, MS. Note: Use latest edition of all designations.

**US Army Engineer Waterways Experiment Station 1953**

US Army Engineer Waterways Experiment Station. 1953. *Test Data, Concrete Aggregates in Continental United States and Alaska*, with annual supplements, Technical Memorandum No. 6-370, Vicksburg, MS.

**American Concrete Institute (Annual)**

American Concrete Institute. Annual. *Manual of Concrete Practice*, Five Parts, Detroit, MI, including:

"Cement and Concrete Terminology," ACI 116R

"Standard Specifications for Tolerances for Concrete Construction and Materials," ACI 117

"Guide to Durable Concrete," ACI 201.2R

"Cooling and Insulating Systems for Mass Concrete," ACI 207.4R

"Standard Practice for Selecting Proportions for Normal, Heavyweight, and Mass Concrete," ACI 211.1

"Chemical Admixtures for Concrete," ACI 212.3R

"Recommended Practice for Evaluation of Strength Test Results of Concrete," ACI 214

"Use of Accelerated Strength Testing," ACI 214.1R

"Guide for Use of Normal Weight Aggregates in Concrete," ACI 221R

**EM 1110-2-2000**

**1 Feb 94**

- "Control of Cracking in Concrete Structures," ACI 224R
- "In-Place Methods for Determination of Strength of Concrete," ACI 228.1R
- "Guide for Concrete Floor and Slab Construction," ACI 302.1R
- "Guide to Cast-in-Place Architectural Concrete Practice," ACI 303R
- "Guide for Measuring, Mixing, Transporting, and Placing Concrete," ACI 304R
- "Placing Concrete by Pumping Methods," ACI 304.2R
- "Placing Concrete with Belt Conveyors," ACI 304.4R
- "Hot Weather Concreting," ACI 305R
- "Cold Weather Concreting," ACI 306R
- "Standard Practice for Curing Concrete," ACI 308
- "Guide for Consolidation of Concrete," ACI 309R
- "Building Code Requirements for Reinforced Concrete (ACI 318) and Commentary," ACI 318/318R
- "State-of-the-Art Report on High Strength Concrete," ACI 363R
- "State-of-the-Art Report on Fiber-Reinforced Concrete," ACI 544.1R
- "Measurement of Properties of Fiber-Reinforced Concrete," ACI 544.2R
- "Guide for Specifying, Mixing, Placing, and Finishing Steel Fiber-Reinforced Concrete," ACI 544.3R
- "Design Considerations for Steel Fiber Reinforced Concrete," ACI 544.4R

**American Society for Testing and Materials (Annual)**  
American Society for Testing and Materials. (Annual).  
*Annual Book of ASTM Standards*, Philadelphia, PA.

Note: Use the latest available issue of each ASTM Standard.

**A-2. Related Publications**

**ER 415-2-100**  
Construction Management Policies, Procedures, and Staffing for Civil Works Projects

**ER 1110-1-1804**  
Geotechnical Investigation

**ER 1110-1-8101**  
Reports of Pertinent Activities at Division Laboratories

**EM 1110-1-2009**  
Architectural Concrete

**EM 1110-1-2101**  
Working Stresses for Structural Design

**EM 1110-2-2005**  
Standard Practice for Shotcrete

**EM 1110-2-2006**  
Roller-Compacted Concrete

**American Concrete Institute 1988**  
American Concrete Institute. 1988. "No-fines Pervious Concrete for Paving," *Concrete International: Design and Construction*, Vol. 10, No. 8, Detroit, MI.

**American Society for Testing and Materials 1978**  
American Society for Testing and Materials. 1978. "The Significance of Tests and Properties of Concrete and Concrete-Making Materials," *ASTM Special Technical Publication No. 169B*, Philadelphia, PA. (Use 169C when it appears ~ probably early in 1994.)

**Bisque and Lemish 1958**  
Bisque, R. E., and Lemish, John. 1958. "Chemical Characteristics of Some Carbonate Aggregate as Related to Durability of Concrete," *Highway Research Board Bulletin* 196, Washington, DC, pp 29-45.

**Buck 1965**  
Buck, A. D. 1965 (Jun). "Investigation of a Reaction Involving Nondolomitic Limestone Aggregate in Concrete," *Miscellaneous Paper No. 6-724*, 38 pp, U.S. Army Engineer Waterways Experiment Station, Vicksburg, MS.

**Buck 1983**  
Buck, A. D. 1983. "Alkali Reactivity of Strained Quartz as a Constituent of Concrete Aggregate," *Miscellaneous Paper*

SL-83-13, U.S. Army Engineer Waterways Experiment Station, Vicksburg, MS.

#### **Buck 1988**

Buck, A. D. 1988. "Use of Pozzolan or Slag in Concrete to Control Alkali-Silica Reaction and Sulfate Attack," Technical Report SL-88-29, U.S. Army Engineer Waterways Experiment Station, Vicksburg, MS.

#### **Bureau of Reclamation 1975**

Bureau of Reclamation. 1975. *Concrete Manual* 8th edition. For sale by Superintendent of Documents, US Government Printing Office, Washington, DC 20402.

#### **Canadian Standards Association 1986**

Canadian Standards Association. 1986 (Oct). "Potential Expansivity of Cement Aggregate Combinations (Concrete Prism Expansion Method)," CAN3-A23.2-M77, A23.2-14A, Supplement No. 2.

#### **Diamond 1976**

Diamond, S. 1976. "A Review of Alkali Silica Reaction and Expansion Mechanisms: 2. Reactive Aggregates," *Cement and Concrete Research*, Vol 6, pp 549-560.

#### **Diamond 1978**

Diamond, S. 1978. "Chemical Reactions Other Than Carbonate Reactions," Chapter 23, *ASTM Special Technical Publication 169B*, pp 700-721.

#### **Dolar-Mantuani 1983**

Dolar-Mantuani, L. 1983. *Handbook of Concrete Aggregates*, Chapter 7, "Alkali-Aggregate Reactivity," Noyes Publications, Park Ridge, NJ, pp 79-125.

#### **Grattan-Bellew 1987**

Grattan-Bellew, P. E., ed. 1987. "Concrete Alkali-Aggregate Reactions," *Proceedings 7th International Conference*, Noyes Publications, Park Ridge, NH, 509 pp.

#### **Grattan-Bellew 1992**

Grattan-Bellew, P. E. 1992. "Microcrystalline Quartz, Undulatory Extinction & the Alkali-Silica Reaction," *Proceedings 9th International Conference*, The Concrete Society, Slough, Vol 1, pp 383-394.

#### **Hadley 1961**

Hadley, David W. 1961. "Alkali Reactivity of Carbonate Rocks--Expansion and Dedolomitization," *Proceedings, Highway Research Board*, Vol 40, pp 462-474, 664 pp.

#### **Hadley 1968**

Hadley, David W. 1968. "Field and Laboratory Studies on

the Reactivity of Sand-Gravel Aggregate," *Journal of PCA R&D Labs*, PCA Research Bulletin No. 221, Vol 10, No. 1 pp 17-33.

#### **Highway Research Board 1964**

Highway Research Board. 1964. "Symposium on Alkali-Carbonate Rock Reactions," *Highway Research Record* No. 45, HRB Publication 1167, 244 pp.

#### **Kosmatka and Panarese 1988**

Kosmatka, Steven H., and Panarese, William C. 1988. *Design and Control of Concrete Mixtures*, 13th ed., Portland Cement Association, Skokie, IL.

#### **MacInnis 1992**

MacInnis, Cameron. 1992. "Guide to Durable Concrete," ACI Committee Report 201.2R-92, *ACI Manual of Concrete Practice*, Part I, American Concrete Institute, Detroit, MI.

#### **Mather 1948**

Mather, Bryant. 1948. "Petrographic Identification of Reactive Constituents in Concrete Aggregate," *Proceedings, American Society for Testing Materials*, Vol 48, pp 1120-1125.

#### **Mather, K. et al 1963**

Mather, Katharine; Luke, Wilbur I.; and Mather, Bryant. 1963 (Jun). "Aggregate Investigations, Milford Dam, Kansas; Examination of Cores from Concrete Structures," Technical Report No. 6-629, 81 pp, U.S. Army Engineer Waterways Experiment Station, Vicksburg, MS.

#### **Meininger 1988**

Meininger, Richard C. 1988 (Aug). "No-Fines Pervious Concrete for Paving," *Concrete International*, American Concrete Institute, Vol 10, No. 8.

#### **Mielenz 1958**

Mielenz, R. C. 1958. "Evaluation of the Quick-Chemical Test for Alkali Reactivity of Concrete Aggregate," *Highway Research Bulletin* No. 171, pp 1-15.

#### **Mindess and Young 1981**

Mindess, Sidney, and Young, J. Francis. 1981. *Concrete*, Prentice-Hall, Englewood Cliffs, NJ.

#### **Natesaiyer and Hover 1985**

Natesaiyer, K., and Hover, K. 1985. "Insitu Identification of ASR Products in Concrete," *Cement and Concrete Research*, Vol 18, pp 455-463.

#### **National Ready-Mixed Concrete Association 1982**

National Ready-Mixed Concrete Association. 1982 (Sep).

**EM 1110-2-2000**  
**1 Feb 94**

*Concrete Plant Standards of the Concrete Plant Manufacturers Bureau*, 8th revision, Spring Street, Silver Spring, MD (also available as CRD-C 514).

**Neeley 1988**

Neeley, Billy D. 1988 (Apr). "Evaluation of Concrete Mixtures for Use in Underwater Repairs," Technical Report REMR-CS-18, U.S. Army Engineer Waterways Experiment Station, Vicksburg, MS.

**Neville 1981**

Neville, Alan M. 1981. *Properties of Concrete*, 3rd Edition, Pitman Publishing, Marshfield, MA.

**Oberholster and Davies 1986**

Oberholster, R. E., and Davis, G. 1986. "An Accelerated Method for Testing the Potential Alkali Reactivity of Siliceous Aggregates," *Cement and Concrete Research*, Vol 16, pp 181-189.

**Pepper 1953**

Pepper, Leonard. 1953. "Tests for Chemical Reactivity Between Alkalies and Aggregate; QuickChemical Test," Technical Memorandum No. 6-368, Report 1, U.S. Army Engineer Waterways Experiment Station, Vicksburg, MS.

**Poole, McLachlan, and Ellis 1988**

Poole, A. B., McLachlan, A., and Ellis, D. J. 1988. "A Simple Staining Technique for the Identification of Alkali-Silica Gel in Concrete and Aggregate," *Cement and Concrete Research*, Vol 18, pp 116-120.

**Porter 1978**

Porter, L. C. 1978. "A 25-Year Evaluation of Concrete Containing Reactive Kansas-Nebraska Aggregates, Report REC-ERC-78-5, Engineering Research Center, Bureau of Reclamation, Denver, CO.

**Saucier 1980**

Saucier, Kenneth L. 1980. "High-Strength Concrete, Past, Present, Future," *Concrete International*, American Concrete Institute, Vol 2, No. 6, pp 46-50.

**Stark 1983**

Stark, David. 1983. "Osmotic Cell Tests to Identify Potential for Alkali-Aggregate Reactivity," *Proceedings, 6th International Conference on Alkalies in Concrete*, Copenhagen.

**Stark 1991**

Stark, David. 1991. "Handbook for the Identification of Alkali-Silica Reactivity in Highway Structures," SHRP-C/FR-91-101, Strategic Highway Research Program, Washington, DC, 49 pp.

**Tye and Mather 1956**

Tye, R. V., and Mather, Bryant. 1956. "Tests for Chemical Reactivity Between Alkalies and Aggregate: Mortar-Bar Test," Technical Memorandum No. 6-368, Report 2, U.S. Army Engineer Waterways Experiment Station, Vicksburg, MS.

**Tynes et al. 1966**

Tynes, W. O., Luke, W. I., and Houston, B. J. 1966. "Results of Laboratory Tests and Examinations of Concrete Cores, Carlyle Reservoir Spillway, Carlyle, Illinois," Miscellaneous Paper No. 6-802, 29 pp, U.S. Army Engineer Waterways Experiment Station, Vicksburg, MS.

**Waddell 1974**

Waddell, Joseph J. 1974. *Concrete Construction Handbook*, 2nd edition, McGraw-Hill, New York.

**Appendix B  
Abbreviations**

ACI .....	American Concrete Institute	EPA .....	Environmental Protection Agency
AEA .....	air-entraining admixture	FCSA .....	Feasibility Cost-Sharing Agreement
AHV .....	Class A, High Velocity	FM .....	fineness modulus
ASTM .....	American Society for Testing and Materials	FRC .....	fiber-reinforced concrete
AWA .....	antiwashout admixture	GDM .....	generic design memorandum
BCO .....	bidability, constructability, and operability	GGBF .....	ground granulated blast-furnace
CE .....	Corps of Engineers	GQA .....	government quality assurance
CECW-EG .....	Geotechnical and Materials Engineering Branch, Civil Works Directorate, Headquarters U.S. Army Corps of Engineers	HRWRA .....	high-range water-reducing admixture
CEWES-SC .....	U.S. Army Engineer Waterways Experiment Station, Structures Laboratory, Concrete Technology Division	HQSACE .....	Headquarters, US Army Corps of Engineers
CONUS .....	Continental United States	MSA .....	maximum size aggregate
CQC .....	contractor quality control	NMSA .....	nominal maximum size aggregate
CSA .....	Canadian Standards Association	NISA .....	nonlinear, incremental structural analysis
CW .....	civil works	PA .....	preplaced-aggregate concrete
DM .....	design memorandum	PED .....	preconstruction engineering and design
DFE .....	durability factor (based on relative dynamic modulus of elasticity)	PMP .....	project management plan
		P&S .....	plans and specifications
		SSD .....	saturated-surface dry condition
		w/c .....	water-cement ratio
		WES .....	Waterways Experiment Station
		WRA .....	water-reducing admixture



## Appendix C Concrete Materials Design Memorandum

### C-1. Concrete Materials Investigation

The scope of the investigation will vary depending on the quantity, criticality of the exposure condition, and the type of structure. Critical exposure condition is defined as an exposure condition which is deleterious to concrete such as freezing and thawing, sulfate exposure, or acid attack. For a small (less than 5,000 yd<sup>3</sup> of concrete), nonhydraulic structure exposed to a noncritical environment, investigation will generally be limited to determining that a commercial ready-mix plant is within acceptable haul distance. Examples of such structures include sidewalks, fireplaces, boat ramps, and picnic table bases in a recreation area or culvert headwalls on an access road. For a small nonhydraulic structure which will be subjected to critical exposure conditions, additional investigations addressing the measures to be specified to mitigate the potential concrete deterioration should be included in the DM. Regardless of the criticality of the exposure condition, if the structure contains 5,000 yd<sup>3</sup> or more of concrete, a more detailed investigation will normally be required. A more rigorous and detailed investigation will also be required for hydraulic structures such as locks, dams, intake structures, powerhouses, major pumping stations, urban floodwalls, concrete-lined channels, tunnel linings, and appurtenant structures of earth-fill dams. A separate DM is required for lock or dam.

### C-2. Concrete Materials Design Memorandum

The following typical information should be covered in concrete materials design memoranda for various types of structures and exposure conditions.

*a. Small nonhydraulic structure (less than 5,000 yd<sup>3</sup> of concrete) subjected to noncritical exposure condition.*

- (1) Concrete quantity.
- (2) Environmental and functional conditions to which concrete will be subjected.
- (3) Source of concrete (available commercial ready-mix plants).
- (4) Availability of aggregate of the quality and grading which is to be specified.
- (5) Determination of strength or w/c requirements.

*b. Small nonhydraulic structure (less than 5,000 yd<sup>3</sup> of concrete) subjected to critical exposure condition.*

- (1) Concrete quantity.
- (2) Description of critical environmental and/or functional conditions to which concrete will be subjected.
- (3) Specifications requirements to be used to obtain satisfactory durability, including thermal considerations of placing temperature and insulation.
- (4) Availability of concrete meeting the specifications from commercial ready-mix plants in the project area.
- (5) Availability of aggregate of the quality and grading which is to be specified.
- (6) Determination of strength or w/c requirements.

*c. Hydraulic structures other than lock or dam or large nonhydraulic structure (5,000 yd<sup>3</sup> or more of concrete) regardless of the criticality of the exposure condition.*

- (1) Structures in this category include:
  - (a) Powerhouse superstructures.
  - (b) Bridges.
  - (c) Fish hatchery complexes.
  - (d) Visitor centers.
  - (e) Water or vehicular tunnel linings.
  - (f) Major pumping stations.
  - (g) Intake structures.
  - (h) Urban floodwalls.
- (2) Brief description and location of project.
- (3) Concrete investigation.
  - (a) Concrete quantity.
  - (b) Climatic and functional conditions to which concrete will be subject (frost action, sulfate attack, acid water, etc.).

**EM 1110-2-2000**

**1 Feb 94**

(c) Concrete qualities to be required.

(d) Typical sectional views of various portions of the structures showing classes of concrete.

(4) Portland cement investigation.

(a) Special requirements to be specified for cementitious materials (low alkali, heat of hydration, false set, C<sub>3</sub>A limitations, etc.).

(b) Availability of these cementitious materials.

(c) Types of cementitious material to be specified with justification.

(d) Testing requirements.

(e) Cost data.

(5) Pozzolan and other cementitious materials investigation.

(a) Types investigated for use.

(b) Availability.

(c) Cost data.

(6) Aggregate investigation.

(a) Description of aggregate sources investigated including photographs of working faces of operating quarries.

(b) Cost estimates.

• Cost at source.

• Distance to project.

• Available mode of transportation.

• Transportation cost.

• How a source's use affects the cost of cementitious material due to aggregate reactivity, water requirement, strength characteristics, etc.

(c) Documentation of aggregate quality.

• Reference

• Reference to TM 6-370 (USAEWES 1953)\*, including volume numbers, area, latitude, longitude, and index number.

• If satisfactory TM 6-370 data are not available, local aggregate sources should be evaluated as outlined in paragraph 2-3.

(d) Service records.

(e) Map showing location of project and deposits.

(f) Volume of concrete of each maximum size aggregate (MSA).

(g) Recommendations as to which sources should be listed in the specifications.

(h) Recommendations for required aggregate quality tests and test limits and discussion of how test limits were set.

(7) Construction plant investigation.

(a) Onsite batch plant requirements, type and capacity.

(b) Mixer requirements, type.

(c) Commercial ready-mix plant availability, capacity and plant type.

(d) Special requirements (time of delivery, temperature control, maximum lift thickness, insulation, curing methods, including requirements for shielding concrete from the direct rays of the sun on areas cured with clear curing compound).

(e) Conveying requirements.

*d. Lock or dam or both (separate DM).*

(1) Description and location of project.

(2) Concrete investigations.

(a) Approximate quantities of concrete in various structures or parts of structures by types or classes.

---

\* References cited in this appendix are given in Appendix A of this EM.

(b) Anticipated number of separate contracts with concrete quantities included in each contract.

(c) Climatic and functional conditions to which concrete will be subjected.

(d) Concrete qualities to be required, include anticipated instructions to be furnished the government resident engineer (see paragraph 6-2).

(e) Sectional views of various portions of the structures showing classes of concrete.

(3) Portland cement investigations.

(a) Types of portland cement to be specified, including special requirements with justification.

(b) Availability of these cementitious materials.

(c) Testing requirements.

(d) Results of laboratory studies to determine necessary cementitious contents to obtain desired concrete qualities.

(e) Map showing location of project and sources.

(4) Pozzolan and other cementitious materials investigation.

(a) Types of pozzolan and other cementitious materials investigated.

(b) Availability of pozzolans and other cementitious materials.

(c) Map showing location of sources and location of project.

(d) Cost data.

(e) Anticipated quantity of pozzolan and other cementitious materials to be used per cubic yard of concrete for various classes of concrete (include test data).

(f) Type(s) of pozzolan and other cementitious materials to be specified or allowed.

(5) Aggregate investigation.

(a) Summary of aggregate investigation conducted.

(b) Description of each source investigated including unsatisfactory sources.

(c) Aggregate processing requirements.

(d) Map showing location of project and sources.

(e) Drawing showing locations and logs of cores or test pits.

(f) Photographs of cores or typical material from sand and gravel deposits.

(g) Photographs of working faces in existing quarries.

(h) Cost estimates.

- Cost at source.

- Distance to project.

- Available transportation.

- Transportation cost.

- Cost of special processing.

(i) Documentation of aggregate quality.

- Reference to TM 6-370, including volume numbers, area, latitude, longitude, and index number.

- If satisfactory TM 6-370 data are not available, local aggregate sources should be evaluated as outlined in paragraph 2-3 of the text.

(j) Discussion of test results.

(k) Service records including photographs where available.

(l) Test quarry-test pit investigations. This may require a separate DM.

(m) Recommendations as to which sources should be listed in the specifications.

(n) Recommendations for required aggregate gradings, aggregate quality tests and test limits, and discussion of how test limits were set.

(6) Construction plant investigation.

- (a) Plant requirement, type, and capacity.
- (b) Mixer requirements, type, and expected capacity and quantity.
- (c) Anticipated area at project site to be reserved for concrete production.
- (7) Conveying equipment.
  - (a) Bucket size.
  - (b) Time of delivery.
  - (c) Conveyor belts, pumps, etc.
- (8) Thermal studies. The discussion of the considerations related to the steps necessary to minimize the effects of the heat of hydration in a massive structure may be of such length as to justify a separate DM or a

separate chapter or appendix in the concrete materials DM. The following items should be discussed:

- (a) Concrete properties used as input to the nonlinear, incremental structural analysis (NISA).
- (b) Results of the NISA.
- (c) Insulation requirements including R-value and duration.
- (d) Special curing requirements.
- (e) Lift thickness.
- (f) Minimum time between lifts.
- (g) Form stripping time.
- (h) Maximum placing temperature.

## Appendix D Alkali-Silica Aggregate Reactions

### D-1. Alkali-Silica Aggregate Reactions

*a. General.* The use of certain aggregates in concrete may result in a chemical process in which particular constituents of the aggregates react with alkali hydroxides dissolved in concrete pore solutions. These alkali hydroxides are derived mostly from the sodium and potassium in portland cement and other cementitious materials, but occasionally alkalis may be introduced into concrete from external sources or may be released slowly from certain alkali-bearing rock components within the aggregate. While many aggregates may react in concrete, distress in structures is observed only when significant amounts of expansive reaction products are formed, and they take up water and expand. The reaction products concerned are hydrous gels whose chemical composition always includes silica, alkalis, and at least a little calcium. The silica component is always derived from the reactive aggregate, which is usually an amorphous or metastable crystalline form of silica; sometimes it is a more complex assemblage of fine-grained silicate components. Some authorities distinguish between "alkali-silica" and "alkali-silicate" reactions, but the distinction is not clear cut. By itself, the formation of alkali-silica reaction product creates little distress; the damage in concrete is associated with subsequent expansion and cracking that occurs when the reaction product gel absorbs water and swells. Keeping affected concrete dry often prevents or at least mitigates the deleterious response. Alkali-aggregate reactions were first observed in California in the 1940's but have subsequently been recognized in many countries. In the United States, alkali-silica reactive aggregates are more common in western and southwestern states; in certain parts of the Southeast, including especially Alabama, South Carolina, and Georgia; and in some of the Great Plains states.

*b. Nature of the reaction.* Field evidence for the occurrence of alkali-silica reaction in a given concrete includes expansion and development of polygonal or map cracking as a characteristic feature, especially when accompanied by gel deposits exuding from the cracks. However, a number of other causes of distress may show superficially similar features, and a petrographic examination of the affected concrete is generally necessary to confirm that alkali-silica reaction is actually taking place. Generally speaking, the higher the alkali content of the cement used, the higher the resulting alkali-hydroxide concentration and pH and the greater the potential for alkali-silica attack. The specific reacting agent is the hydroxide

ion itself. The hydroxide ions break Si-O-Si bonds in the reactive silica or siliceous aggregate components, thus breaking up their cross-linked structure and isolating and dissolving individual silica tetrahedral units. In the absence of calcium, such reaction merely produces dissolved silica. However, in the presence of the solid calcium hydroxide always found in hydrated cement, an alkali-silica gel containing some calcium is formed. In the past, it has been suggested that only gels of minimum calcium content were expansive and gels of higher calcium content were limited swelling gels not capable of causing distress, but some workers now suggest that this seems not to be the case. One of the common petrographic features of alkali-silica reaction is the occurrence of a zone immediately surrounding the reacting aggregate particle in which the cement paste is partially or wholly depleted of calcium hydroxide, the latter having been incorporated into the gel. The actual distress in concrete is associated not with formation of the gel product but with subsequent expansion taking place when gel absorbs water (or solution) and swells. The swelling pressure generated may be of the order of 7 MPa (1,000 psi), sufficient to crack the surrounding paste. If many aggregate grains have reacted to form gel and if sufficient water is available, the combined effect results in macroscopic swelling and eventually a visible crack pattern develops. In some concrete structures that are geometrically sensitive, the irregular expansion itself may be highly damaging to proper functioning, even if visible cracks or other evidences of concrete deterioration are hardly developed. Reactions with strained quartz and with reactive silicate aggregates generally are slower than other alkali-silica reactions, but slow expansion may continue for many years. Such reactions may produce comparatively little reaction gel and are particularly difficult to identify without petrographic examination. Among the unusual features of the alkali-silica reaction is the existence of a so-called "pessimism effect." If mortars or concretes are made using varying proportions of reactive and inert aggregate, the expansion may be greatest for a mixture with a comparatively small proportion of the reactive component. The proportion giving rise to the greatest expansion is the pessimism proportion. This proportion is particularly low with opal. With most other common types of reactive aggregate, the pessimism proportion is usually higher, and in some cases, it is 100 percent, i.e., the pessimism effect does not occur.

### D-2. Criteria for Recognition of Potentially Deleterious Constituents in Aggregate

A number of siliceous components of aggregates may be potentially reactive. Reactive aggregate components may be found in igneous, sedimentary, or metamorphic rocks of

various textures and ages. Among the more commonly encountered reactive aggregate components are:

*a. Reactive substances.*

(1) Opal. Opal is a variety of amorphous silica with a porous internal structure which contains water. Opal may occur in cherts, volcanic rocks, shales, sandstones, and carbonate rocks; frequently, it may occur in segregated forms in cavity fillings, crack linings, or as cementing material in concretions. Opal is the most reactive of the various reactive aggregate components ordinarily encountered and may cause damage in concrete when as little as a fraction of a percent is present in the aggregate.

(2) Chalcedony. Chalcedony is a siliceous component of some cherts; microscopically it is distinguished by radiating sheaf-like or fibrous structures embedded in a groundmass from which they cannot be separated. Chalcedonic material is largely very fine quartz, but amorphous silica may be present as well.

(3) Volcanic glass. Particles of volcanic glass or sometimes devitrified volcanic glass in aggregates may be reactive, depending on composition. Acid glasses (those of silica content above 65 percent) and intermediate glasses (of silica contents between 55 and 65 percent) are commonly reactive; more basic glasses (silica content below 55 percent) are less so. Reactive glasses may be identified by refractive indices below 1.57. The presence of water in volcanic glasses seems to be associated with reactivity.

(4) Tridymite and cristobalite. These are crystalline forms of silica that are metastable at ordinary temperatures but that may be found in various igneous rocks, especially andesites and rhyolites.

*b. Other potentially reactive substances.* In addition to these substances just listed, the following may also be reactive:

(1) Quartz. Well crystallized quartz may be reactive and may give rise to problems in concrete if the crystals are strained and finely crushed material produced as in fault zones (mylonite) by virtue of previous geological activity. Strained quartz can be detected petrographically by measurement of the undulatory extinction angle. Rocks such as granites and sandstones may thus be suspect if the formations from which they are derived have a history of extensive metamorphic activity.

(2) Silicates. Various sedimentary or metamorphic rock types containing clays or micas have been observed to

be reactive. Such rock types include graywackes, argillites, phyllites, siltstones, etc. There is considerable dispute as to whether the reactive component is finely divided quartz or amorphous silica within the rock or whether the reaction involves the clay mineral or mica components. Alkali reactions with such rock types tend to be unusually slow and may escape detection by the normal screening tests for reactive aggregate. If aggregate to be used contains significant contents of such rock types, low-alkali cement should be used where available. If not available or if it is available only at greatly increased cost, additional studies may be required and HQUSACE should be notified (Attention: CECW-EG).

(3) Sandgravel. "Sandgravel" aggregates in parts of Kansas, Nebraska, and Wyoming, especially those from the Platte, Republican, and Laramie Rivers, have been involved in the deterioration of concrete. Aggregates from these areas should be viewed with suspicion unless an acceptable service record has been compiled or no reactive constituents are found on petrographic examination.

(4) Disseminated silica in limestones. A number of instances of alkali silica reactivity leading to serious distress have been observed with limestone aggregate that contains small amounts of dispersed silica, often skeletal remains of small organisms. The fact that limestone aggregates may not be of the characteristic dolomite composition and impurity content that results in alkali-carbonate reaction does not preclude the possibility of alkali-silica reaction if disseminated reactive silica exists in the material.

### **D-3. Methods of Determining the Potential for Reactivity**

*a. Standard methods.*

(1) American Society for Testing and Materials (ASTM) C 227 (CRD-C 123) - "Potential Alkali Reactivity of Cement-Aggregate Combinations (Mortar-Bar Method)."\* In this method the length change of mortar bars prepared with the aggregate in question (prepared to a specified particle size distribution) and either high-alkali or the specified job cement is measured over a 1-year period.

---

\* Test methods cited in this manner are from the *Annual Book of ASTM Standards* (ASTM 1992) and from the *Handbook of Concrete and Cement* (U.S. Army Engineer Waterways Experiment Station (USAEWES) 1949), respectively. References cited in this appendix are given in Appendix A of this EM.

(2) ASTM C 289 (CRD-C 128) - "Potential Reactivity of Aggregates (Chemical Method)." In this so-called "quick chemical test," finely crushed aggregate is immersed in concentrated sodium hydroxide and heated under pressure for 24 hours. The reaction is monitored by subsequent determination of the amount of dissolved silica and the degree of reduction in the alkalinity of the solution. This test gives an indication of possible reactivity but is not sufficiently definitive to be used alone without additional testing.

(3) ASTM C 295 (CRD-C 127) - "Petrographic Examination of Aggregates for Concrete." This is the procedure for petrographic examination of aggregates, including the determination of whether potentially deleterious components are present. The services of a qualified petrographer are required.

(4) A test method involving measurement of length change of concrete prisms rather than mortar bars has recently been adopted by the Canadian Standards Association (CSA) (CSA A23.2-14A 1986). It is intended to overcome criticism of other tests that they do not involve concrete specimens.

*b. Nonstandard methods of determining the potential for alkali reactivity.*

(1) General. A number of nonstandard methods have been developed to determine potential reactivity of aggregates. Noteworthy among these is the osmotic method described by Stark, high-temperature accelerated test described by Oberholster and Davies (1986), and two very recent rapid tests: a staining procedure developed by Poole, McLachlan, and Ellis (1988) and a fluorescent method reported by Natesaiyer and Hover. While none of these procedures has yet replaced any of the standard methods of test for reactive aggregates, they may constitute useful supplementary tests that can be carried out relatively quickly. Most of them require some special apparatus.

(2) Osmotic method. In the osmotic method, powdered aggregate is immersed in sodium hydroxide and separated by a cement paste membrane from a reservoir of sodium hydroxide of the same concentration. The osmotically induced flow of the fluid from the reservoir to the solution containing the aggregate is monitored, and if it exceeds a specified amount in several weeks, the aggregate is considered reactive.

(3) Accelerated test. In the high-temperature accelerated test, mortar prisms made according to the procedure of ASTM C 227 (CRD-C 123) are immersed in

a one-normal sodium hydroxide solution at 80 °C (176 °F) for 12 days with measurements of expansion made daily. An expansion of 0.11 percent or greater over this period is taken as indicating that the aggregate is deleteriously reactive.

(4) Staining test. In the staining procedure, the potentially reactive rock is reacted with a special alkali solution so that the gel formed gives rise to a blue-colored complex; the intensity of the color is measured and related to the reactivity of the rock.

(5) Fluorescence test. In the fluorescence method, uranyl acetate solution is applied to the concrete; if gel has formed, uranyl ions are quickly exchanged for alkali ions. The presence of such uranyl-bearing gel is easily observed by examination under ultraviolet light.

#### **D-4. Reliability of Available Test Methods**

*a. General.* Despite continuing research and improvements, none of the standard methods can be relied on independently or collectively to provide an unquestionably definitive answer, especially to the question of whether seriously deleterious reaction should be expected if small amounts of moderately reactive components are discovered.

*b. Petrographic examination.* The results of petrographic examination by an experienced petrographer should provide an indication of the presence of any potentially reactive components in the aggregate. The mortar-bar test should provide an indication of whether any reactions taking place will be extensive enough to induce unacceptable levels of expansion. Thus, combining the results of petrographic examination with mortar-bar expansion test results is considered to be the most reliable way to predict possible excessive expansion using the standard test procedures. However, contradictory indications will sometimes be provided by the results of the two methods, and both methods entail certain uncertainties. Petrographic examination requires interpretation, and small amounts of certain important components, especially opal, can readily be missed. Mortar-bar tests require at least 6 months and may not even then detect certain slow forms of reactivity. Furthermore, the reproducibility of the mortar-bar test is not high.

*c. Quick chemical test.* The quick chemical test is generally considered to be of limited reliability; its major advantage is that it can be accomplished in little more than a day. Spurious results may be obtained in the presence of carbonate rock components.

*d. Test samples.* All of these methods require that the small volume of aggregate sample examined be truly representative of the very large and often inhomogeneous deposit being sampled. This often poses an impossible condition, even when standard methods of aggregate sampling (e.g. those specified in ASTM D 75 (CRD-C 155) and ASTM D 3665) are employed.

*e. CSA concrete test.* The CSA concrete test was designed to provide a rapid indication of reactivity particularly with a fine-grained silicate rock. Unfortunately, since no minimum expansion limit is prescribed, interpretation of the results are difficult.

*f. Osmotic test.* The osmotic test has been used for a number of years by the Portland Cement Association and its Construction Technology Laboratories Division and appears to give promising results. Similarly, the accelerated high temperature test has been used for a few years by the National Building Research Institute in South Africa, and it too appears promising for future adoption. The staining and fluorescent analysis procedures are so new that their reliability has not been assessed.

#### **D-5. Criteria for Evaluating Potential Reactivity**

*a. General.* The fine and coarse aggregates suggested for use in a given concrete mixture should be evaluated separately for potential reactivity, regardless of whether or not they come from the same source.

*b. Petrographic analysis results.* A fine or coarse aggregate will be classified as "potentially deleteriously reactive," i.e. capable of causing damage to concrete made with high-alkali cement, if the petrographic examination reveals any of the following:

- (1) Presence of any opal.
- (2) More than 5 percent of particles of chert in which any chalcedony is detected.
- (3) More than 3 percent of particles of glassy igneous rocks in which any acid or intermediate glass is detected.
- (4) More than 1 percent of particles in which any tridymite or cristobalite is detected.
- (5) More than 20 percent of particles containing strained quartz in an aggregate in which the measured average extinction angle is at least 15 degrees.

(6) More than 15 percent of particles consisting of graywacke, argillite, phyllite, or siltstone containing any very finely divided quartz or chalcedony.

*c. Mortar-bar results.* A fine or coarse aggregate will be classified as "potentially deleteriously reactive" if the expansion measured in tests with cement containing not less than 1.0 percent alkalis calculated as  $\text{Na}_2\text{O}$  is more than 0.05 percent at 6 months or 0.10 percent at 1 year. Additionally, the following interpretations should be made:

(1) Measured expansions greater than 0.10 percent at any age are indications that the aggregate should be regarded as potentially deleteriously reactive.

(2) Measured expansions greater than 0.05 percent at 6 months but less than 0.10 percent at 1 year usually indicate that the aggregate is not deleteriously reactive, but in borderline cases, the slope and trend of the length change versus time curve should be examined for assistance in interpretation.

(3) If the aggregate contains strained and very finely divided quartz, but either the content of such particles or the degree of strain is such that the criteria mentioned previously for strained quartz aggregate are not exceeded, additional special mortar-bar tests should be carried out. In these tests the mortar bars are made using a nonreactive fine aggregate, but five particles of a size between 12.5 and 19.0 mm (1/2 to 3/4 in.), consisting entirely or mostly of the strained quartz, are inserted into each bar. The bars are stored under conditions of 100 percent RH and a temperature of  $60^\circ \pm 5^\circ\text{C}$  ( $140^\circ \pm 10^\circ\text{F}$ ). The aggregate so tested will be considered potentially deleteriously reactive if expansion at 6 months exceeds 0.025 percent or expansion at 1 year exceeds 0.04 percent. These special criteria are invoked because of the observed slow rate of expansion of concrete containing reactive strained and very finely divided quartz.

*d. Quick-chemical test criteria.* A fine or coarse aggregate will be classified potentially deleteriously reactive or deleteriously reactive if the data point plotted for it falls to the right of the line on the standard graph accompanying the description of the test method.

*e. Service record.* A fine or coarse aggregate will be classified as potentially deleteriously reactive when service records establish that excessive expansion due to alkali-silica reaction has occurred in a structure in which the aggregate has been used. Where service records indicate deleterious



reactivity, the aggregate should be so classed, regardless of laboratory test results. As previously indicated, the laboratory test methods cannot be absolutely relied on, individually or collectively, to provide an unquestionably positive indication of potentially excessive expansion. Every effort should be made to obtain prior performance records, especially where cements of high-alkali contents have been used, and especially if exposure conditions have been similar to those predicted for the proposed work. It should be noted that some reactions occur slowly and take years to become evident. Care should be taken on younger structures.

*f. Blended aggregates.* If either the coarse or fine aggregates for a project will be blended from aggregate derived from two or more sources, the combined coarse or fine aggregate, in the proportion intended for use, will be evaluated for potential reactivity. In the petrographic examination, the estimated amounts of potentially deleterious constituents present will be calculated by the method of weighted averages, using the proposed grading of the blended coarse or fine aggregate. For the mortar-bar test, where fine aggregate is to be blended from two or more sources, each sieve fraction used in the test shall be in proportion to that sieve fraction in the proposed blended fine aggregate. For blended coarse aggregates, the crushed material from which the test mortars are prepared shall include all of the rock types occurring in the combined coarse aggregate, in the percentages of each size group anticipated for the combined grading of the project aggregate. Similar procedures should be used to select aggregate to be powdered for sample material for use in the quick-chemical test.

*g. Application of standard test criteria.* It is preferred that each fine or coarse aggregate be evaluated based on a combination of service record, petrographic examination, mortar-bar, and quick-chemical test results. If the indications disagree, aggregates are to be considered potentially deleteriously reactive if so indicated by the following combinations of tests:

- (1) Service records and mortar-bar test results.
- (2) Service records and petrographic examination.
- (3) Mortar-bar test results and quick-chemical test results.
- (4) Petrographic examination and quick-chemical test results.
- (5) If in the absence of mortar-bar test results,

petrographic examination indicates that the aggregate is potentially deleteriously reactive, but this is not confirmed by either service record or results of the quick-chemical test, the aggregate should not be used until the results of mortar-bar testing can be obtained.

#### **D-6. Control of Alkali-Silica Aggregate Reactions**

Aggregates considered potentially deleteriously reactive should not be used in concrete that will be exposed to moisture in service. If such use is unavoidable, suitable precautions must be taken to minimize the probability of harmful internal expansion and cracking. Such precautions include the following:

*a. Use of low-alkali cements.* If it appears likely that low-alkali cement, i.e., cement meeting the optional requirement for low-alkali content of ASTM C 150 (CRD-C 201) will be available at little or no increase in cost, this optional requirement should be invoked and such cement used. However, experience has indicated that such use does not provide a complete guarantee that no distress will be experienced, especially if (a) the structure is a slab on grade exposed to relatively high temperature and low relative humidity conditions so that the alkalis become concentrated in the region near the surface, (b) alkali from external sources can be expected to penetrate the concrete, or (c) alkalis are released internally from certain aggregate components as a result of reaction with cement hydration products.

*b. Use of slag or pozzolans.* If low-alkali cement is not available or available only at excessive cost, the use of a GGBF slag or a mineral admixture such as a pozzolan (fly ash, silica fume, or natural pozzolan) (or a blended cement containing such a component) is indicated. These components effectively absorb hydroxide ions and alkali ions from the concrete pore solutions, thus reducing the driving force for the deleterious alkali-silica chemical reaction with aggregate. While blended portland blast-furnace slag cements are not widely available, separately batched GGBF slag may be used to provide a GGBF slag-portland-cement concrete highly resistant to alkali-silica attack. Silica fume added in much smaller percentages than slag has also been highly effective, although the cost involved may be high. Some slags, fly ashes, and other pozzolans provide effective protection against the alkali-silica reaction, some do not. Fly ashes and natural pozzolans must meet the requirements of ASTM C 618, Table 2A, Supplementary Optional Physical Requirements, Reactivity with Cement Alkalies, to be considered effective. Slag must meet the requirements of ASTM C 989, Appendix X3, to be considered effective. These

1 Feb 94

specifications give criteria for determining the effectiveness of the material. Silica fume should be considered a pozzolan for this discussion and should be evaluated per ASTM C 618.

*c. Determination of the minimum amount of pozzolan or slag to use to control alkali-silica reaction.*

(1) The proposed material should be given a preliminary characterization by a combination of physical, chemical, and petrographic methods to assure that it is a reasonable candidate material and that it meets the applicable specifications.

(2) Prepare four mortar mixtures according to ASTM C 441 (CRD-C 257). Use the proposed cement or high-alkali cement and Pyrex glass as the aggregate on the assumption that if the candidate pozzolan (fly ash, silica fume, or natural pozzolan) or slag will control this combination, it will control the actual job materials. Pyrex glass is preferred since its pessimum amount is 100 percent. This avoids the need to conduct tests to determine the pessimum amount of reactive material in the actual aggregate and possible fluctuations in test results due to nonuniformity of the aggregate. A control mixture without pozzolan or slag should be made.

(3) Test the bars from these mixtures by ASTM C 441 (CRD-C 257) for a minimum of 14 days, longer if possible.

(4) Evaluate the expansion data to determine the amount of slag or pozzolan needed to keep expansion from exceeding the criteria given in the appropriate specifications.

(5) This is the amount to use in the concrete. It may be necessary to make slight modifications to the intended concrete mixture to assure desired workability or strength gain or other needed properties.

(6) Once a material and its amount to use has been selected, the continued suitability of this material during the duration of construction should be periodically monitored by selected physical or chemical or petrographic methods or a combination of these. For example, one might use fineness, silica content, or relative amount of glass. Similar monitoring should be used for the cement. The frequency

of testing and parameters to be used must be determined and documented in the concrete materials design memorandum.

(7) It is desirable to approximate the actual environmental conditions during the laboratory testing. If there is a significant source of alkali from the environment, it may affect the control provided by the pozzolan or slag and could necessitate the use of nonreactive aggregate.

*d. Decreasing the availability of water.* Concretes batched at low w/c have only a limited supply of internal water needed to cause the alkali-silica reaction product gel to swell, and the permeability of such concretes to outside water is also reduced. Thus, the deleterious consequences of the alkali-silica reaction may be slowed down significantly. Experience has also indicated that when concrete dries sufficiently that the relative humidity in the pores of the concrete falls below and remains below 80 percent, no adverse expansion occurs. However, the chemical reaction is not necessarily precluded, and subsequent rewetting may produce rapid and serious expansions.

*e. The sandgravel problem.* So-called sandgravel aggregates derived from river-transported deposits along the Platte, Republican, Laramie, and several other rivers in the Great Plains states (notably Kansas, Nebraska, Colorado, Wyoming, and to a lesser extent Iowa and Missouri) cause characteristic problems in concrete. In part, these difficulties are due to the poor grading of these materials, but alkali-aggregate reactivity is associated with glassy volcanic components in the western part of the region and opal combined with lesser amounts of volcanic glass to the east. Neither the use of low-alkali cements nor the use of pozzolans have completely succeeded in controlling the problem. Accordingly, aggregates from these sources should be avoided if economically feasible to do so. If this is not feasible, replacement of at least 45 percent of the aggregate with crushed limestone appears to be an effective remedy when combined with the use of low-alkali cement.

*f. Decreasing the amount of reactive aggregate.* It may be economical to use some proportion of local reactive aggregate with the rest being more expensive imported nonreactive aggregate, rather than use all imported aggregates. The proportion of reactive aggregates that can safely be used must be carefully investigated.

## Appendix E Alkali-Carbonate Rock Reactions

### E-1. General Statement.

The results of studies that have been reported indicate that four types of alkali-carbonate rock reaction may be recognized in concrete. A thorough review of research through 1964 is contained in paragraph E-4 of this manual (Highway Research Board 1964).\* It is possible that future work will show that some of these are merely different manifestations of the same reaction, shown by different rocks under a variety of circumstances. The four types of reactions are discussed in the following subparagraphs:

#### *a. Reactions involving nondolomitic carbonate rocks.*

Some rocks which contain little or no dolomite may be reactive (Mather et al. 1963; Buck 1965). The reaction is characterized by reaction rims which are visible along the borders of cross sections of aggregate particles. Etching these cross-sectional surfaces with dilute hydrochloric acid reveals that the rims are "negative" rims, i.e. the reaction rim zone dissolves more rapidly than the interior of the particle. The evidence to date indicates that the reaction is not harmful to concrete and may even be beneficial.

#### *b. Reactions involving dolomite or highly dolomitic carbonate rocks.*

The reaction of dolomite or highly dolomitic aggregate particles in concrete has been reported (Tynes et al. 1966). The reaction was characterized by visible reaction rims on cross sections of the aggregate particles. When these cross-sectional areas of aggregate particles were etched with acid, the rimmed area dissolved at the same rate as the nonrimmed area. No evidence was reported that this reaction was damaging to concrete.

#### *c. Reactions involving impure dolomitic rocks.*

The rocks of this group have a characteristic texture and composition. The texture is such that larger crystals of dolomite are scattered in and surrounded by a fine-grained matrix of calcite and clay. The rock consists of substantial amounts of dolomite and calcite in the carbonate portion, with significant amounts of acid-insoluble residue consisting largely of clay. Two reactions have been reported with rocks of this sort, as follows:

(1) Dedolomitization reaction. This reaction is believed to have produced harmful expansion of concrete (Hadley 1961). Magnesium hydroxide, brucite ( $Mg(OH)_2$ ),

is formed by this reaction; its presence in concrete which has expanded and which contains carbonate aggregate of the indicated texture and composition is strong evidence that this reaction has taken place.

(2) Rim-silicification reaction. This reaction is not definitely known to be damaging to concrete, although there are some data which suggest that a retardation in the rate of strength development in concrete is associated with its occurrence. The reaction is characterized by enrichment of silica in the borders of reacted particles (Bisque and Lemish 1958). This is seen as a positive or raised border at the edge of cross sections of reacted particles after they have been etched in dilute hydrochloric acid. Reaction rims may be visible before the concrete surfaces are etched. Fortunately, carbonate rocks that contain dolomite, calcite, and insoluble material in the proportions that cause either the dedolomitization or rim-silicification reactions are relatively rare in nature as major constituents of the whole product of an aggregate source.

### E-2. Criteria for Recognition of Potentially Harmfully Reactive Carbonate Rocks

These criteria serve to indicate those dolomitic carbonate rocks capable of producing the dedolomitization or rim-silicification reaction. Since the reactions generated by some highly dolomitic or by some nondolomitic carbonate rocks are not known to be harmful to concrete, no attempt is made to provide guides for recognition of these rocks at this time.

#### *a. Petrographic examination.*

When petrographic examinations are made according to ASTM C 295 (CRD-C 127) of quarried carbonate rock or of natural gravels containing carbonate-rock particles, adequate data concerning texture, calcite-dolomite ratio, the amount and nature of the acid-insoluble residue, or some combination of these parameters will be obtained to recognize potentially reactive rock. Rocks associated with observed expansive dedolomitization have been characterized by fine-grain size (generally 50 micrometres or less) with the dolomite largely present as small, nearly euhedral crystals generally scattered in a finer-grained matrix in which the calcite is disseminated. The tendency to expansion, other things being equal, appears to increase with increasing clay content from about 5 to 25 percent by weight of the rock, and also appears to increase as the calcite-dolomite ratio of the carbonate portion approaches 1:1.

#### *b. Testing.*

Samples of rock recognized as potentially reactive by petrographic examination will be tested for length change during storage in alkali solution in accordance

\* References cited in this appendix are given in Appendix A of this EM.

**1 Feb 94**

with ASTM C 586 (CRD-C 146). Rock characterized by expansion of 0.1 percent or more by or during 84 days of test by ASTM C 586 should be classified as potential reactive.

*c. Service record.* If adequate reliable data are available to demonstrate that concrete structures containing the same aggregate have exhibited deleterious reactions, the aggregate should be classified as potentially reactive on the basis of its service record.

### **E-3. Control of Alkali-Carbonate Reaction**

The application of engineering judgment will be required in making the final decision as to which rocks are to be classified as innocuous and which are to be classified as potentially reactive. Once a rock has been classified as potentially reactive, the action to be taken should be as indicated in the following subparagraphs.

*a. Reactive aggregate.* Avoid use of aggregate of rock classified as potentially reactive by appropriate procedures such as selective quarrying.

*b. Other control methods.* If it is not feasible to avoid the use of rock classified as potentially reactive, then specify the use of low-alkali cement and pozzolan, the use of the minimum aggregate size that is economically feasible, and dilution so that the amount of potentially reactive rock does not exceed 20 percent of the coarse or fine aggregate or 15 percent of the total if reactive material is present in both.

*c. Aggregate source.* If it is not practical to enforce conditions in subparagraphs a or b, then the aggregate source that contains potentially reactive rock shall not be indicated as a source from which acceptable aggregate may be produced.