

EM 1110-2-2102  
30 September 1995

**US Army Corps  
of Engineers**

**ENGINEERING AND DESIGN**

---

# **Waterstops and Other Preformed Joint Materials for Civil Works Structures**

**DISTRIBUTION STATEMENT A**  
Approved for Public Release  
Distribution Unlimited

**ENGINEER MANUAL**

**20020626 120**

|   |  |  |
|---|--|--|
| <p>CECW-EG</p> <p>Engineer<br/>Manual<br/>1110-2-2102</p> | <p>Department of the Army<br/>U.S. Army Corps of Engineers<br/>Washington, DC 20314-1000</p>                           | <p>EM 1110-2-2102</p> <p>30 September 1995</p> |
|   | <p>Engineering and Design</p> <p>WATERSTOPS AND OTHER PREFORMED<br/>JOINT MATERIALS FOR CIVIL WORKS<br/>STRUCTURES</p> |  |
|   | <p><b>Distribution Restriction Statement</b><br/>Approved for public release; distribution is<br/>unlimited.</p>       |  |

### **AVAILABILITY**

Copies of this and other U.S. Army Corps of Engineers publications are available from National Technical Information Service, 5285 Port Royal Road, Springfield, VA 22161. Phone (703)487-4650.

Government agencies can order directly from the U.S. Army Corps of Engineers Publications Depot, 2803 52nd Avenue, Hyattsville, MD 20781-1102. Phone (301)436-2065. U.S. Army Corps of Engineers personnel should use Engineer Form 0-1687.

### **UPDATES**

For a list of all U.S. Army Corps of Engineers publications and their most recent publication dates, refer to Engineer Pamphlet 25-1-1, Index of Publications, Forms and Reports.

DEPARTMENT OF THE ARMY  
U.S. Army Corps of Engineers  
Washington, DC 20314-1000

EM 1110-2-2102

CECW-EG

Manual  
No. 1110-2-2102

30 September 1995

**Engineering and Design**  
**WATERSTOPS AND OTHER PREFORMED JOINT MATERIALS**  
**FOR CIVIL WORKS STRUCTURES**

- 1. Purpose.** This manual provides guidance for the selection and use of waterstops and other preformed joint materials for preventing passage of excessive amounts of water, water-borne matter, gases, other fluids, and other unwanted substances into or through the joints of concrete structures.
- 2. Applicability.** This manual is applicable to HQUSACE elements and USACE commands having civil works responsibilities.
- 3. Discussion.** Most concrete structures have contraction, expansion, and construction joints. Joints can be a path for unwanted matter, liquids, solids, and gaseous substances to enter and pass through the concrete joint and possibly cause damage to the integrity and serviceability of the structure. Waterstops and other preformed joint materials are a primary line of defense against the passage of excessive amounts of these substances. This manual provides information and data on the various waterstops, preformed compression seals, and other preformed joint materials; their shapes, sizes, and the physical properties that are available to the designers of concrete structures.

FOR THE COMMANDER:



ROBERT H. GRIFFIN  
Colonel, Corps of Engineers  
Chief of Staff

---

This manual supersedes EM 1110-2-1911, dated 31 May 1983.

## **Chapter 1 Introduction**

### **1-1. Purpose**

This manual provides guidance on effective and economical selection, evaluation, and use of waterstops, preformed compression seals, and other preformed joint materials in the construction of concrete structures. It provides information on types of waterstops and other preformed joint materials used in hydraulic and non-hydraulic concrete structures, including locks, dams, floodwalls, storage tanks, pavements, buildings, bridge decks, and other concrete structures.

### **1-2. Applicability**

This manual is applicable to HQUSACE elements and USACE commands having civil works responsibilities.

### **1-3. References**

A list of cited references is presented in Appendix A. The reader may refer to American Concrete Institute (ACI) Committee Report 504R-90, "Guide to Sealing Joints in Concrete Structures" for additional guidance.

### **1-4. Definitions**

A list of terms and their definitions is presented in Appendix B. These definitions are not necessarily

applicable beyond this manual. The usefulness of these terms within this manual implies that special care is needed whenever waterstop is described formally in a design memorandum or a construction contract.

### **1-5. Background**

Concrete is normally subject to changes in length, shape, or volume caused by changes in temperature, moisture content, reactions with atmospheric carbon dioxide, or by the application of loads. One method of controlling and minimizing the effect of these changes or movements is to provide joints at which the movement can be accommodated without loss of integrity of the structure. There are many other reasons for providing joints in concrete structures such as at doors, windows, cladding, mechanical breaks, or to simplify construction. These joints must usually be sealed to prevent passage of excessive amounts of gases, liquids, or other unwanted substances into and through the joint openings. Some preformed joint materials not only prevent the passage of undesirable substances but also prevent the entry of hardened particles into the joint that may eventually cause the concrete to crack or chip along the edge of the joint.

## Chapter 2 Joints and Their Functions

### 2-1. General

Joints are required in most concrete construction. Concrete is subject to physical changes in length, width, height, shape, and volume of its mass when subjected to environmental changes and mechanical conditions surrounding it. The effects may be permanent contraction from drying shrinkage, carbonation, or creep; abnormal changes from chemical reactions of sulfate or alkali attacks; or simply the application of a load on the concrete. As movement of the concrete occurs and is restrained by internal or external conditions, whether permanent or transient, the concrete can relieve the internal stresses by forming a joint commonly referred to as a crack. Designers minimize the unsightly appearance of self-formed cracks by introducing joints into the concrete to accommodate for the movement without loss of structural integrity. Joints may also be used in facilitating and accommodating the construction process.

### 2-2. Types of Joints

*a. Contraction joints.* To regulate the cracking occurring from the unavoidable and unpredictable contraction of concrete, contraction joints (also referred to as control joints) are designed into the structure. Contraction joints divide a structural element into two or more smaller elements by forming a complete separation from the adjacent element. Contraction joints may be made during construction by forming the joint with a strip of wood, plastic, or metal; or after construction by saw cutting the joint. The contraction joint may be made to the full depth of the concrete or it may be only partially made and allowed to crack below the control joint the remaining depth of the concrete.

*b. Expansion joints.* To prevent concrete from crushing, distorting, displacing, buckling, or warping from

compressional forces transmitted from abutting concrete that occurs from movement caused by expansion, expansion joints (also referred to as isolation joints) are placed into the concrete structure. Expansion joints are commonly designed to isolate structural elements from each other such as walls or columns from floors and roofs, pavements from bridge decks and piers, or where wall elements change directions. Expansion joints are commonly made during construction but may be incorporated following construction if needed. Expansion joints are made the full depth of the concrete and of sufficient width to avoid the likelihood of the abutting concrete elements from touching each other in the future. Dowels and keyways may be used across expansion joints to resist undesirable lateral or vertical movement of the concrete elements.

*c. Construction joints.* To assist in the construction and in the placement of concrete, construction joints are designed and created at certain locations during large massive concrete placements as scheduled interruptions. The concrete surface at the point of stoppage becomes a construction joint when the concrete placement continues. Size of placement and time are contributing factors for construction joints. Some construction joints are unavoidable due to unscheduled interruption of concreting operations. Construction joints may be designed to coincide with contraction or expansion joints where the concrete surfaces are not bonded. In monolithic placements, the two concrete surfaces may be required to be fully bonded across the construction joint for structural integrity. Construction joints may be formed in any direction depending on the placement stoppage point.

*d. Special-purpose joints and cracks.* Hinge joints, articulated joints, and sliding joints are special-purpose joints designed for a particular special-purpose function. Cracks are self-made joints that occur almost uncontrollably within the concrete from a variety of reasons. Most cracks affect the aesthetics of the concrete and not the structural integrity of the concrete element or structure.

## Chapter 3 Waterstops and Other Prefomed Joint Materials

### 3-1. General

This manual is primarily concerned with preformed joint materials as obtained from manufacturers. The material differs from the field-molded type of joint sealants because the material configuration is predetermined by design for a known or fixed application or condition. Prefomed joint materials are divided into two classes, rigid and flexible. The flexible class of joint material is the most prevalent of the preformed joint materials used and the primary topic of this manual. This manual covers aspects of the rigid class but only to a limited degree.

### 3-2. Waterstops

*a. General.* Waterstop is a form of preformed joint material, metallic or nonmetallic, designed to stop the flow or migration of water through open joints. Waterstops may be used in many different types of concrete structures but are primarily used in the monolith joints of hydraulic concrete structures such as navigation locks, dams, floodwalls, and control structures to stop the passage of water and waterborne matter through the joint.

*b. Material.* Waterstops may be either metallic or nonmetallic. Metallic waterstops are rigid; made from steel, copper, bronze, or lead. Metallic waterstops may be used in large dams and heavy construction projects where strength rather than flexibility is needed. Nonmetallic waterstops are usually composed of natural rubber; synthetic rubbers such as butyl rubber, neoprene, styrene butadiene rubber, and nitrile butadiene rubber; and polyvinyl chloride. Nonmetallic waterstops provide flexibility rather than strength and must possess good extensibility, good recovery, chemical resistance, and fatigue resistance. Some nonmetallic waterstops are thermoplastic in that they can be easily spliced together at the jobsite or configured for special joints.

*c. Types.* Waterstops are shaped for particular applications. Most metallic waterstops are normally flat but may be preshaped and folded in "Z" and "M" cross-sectional shapes to accommodate unique configurations for special applications. Lead and bronze waterstops are more ductile than the other metallic types and can be shaped more readily. Stainless steel and copper waterstops are resistant to corrosion. Copper waterstops,

specified at 0.686 mm (0.0270 in.), should ensure a suitable material. Where steel is desired, 0.925-mm (0.0375-in.) stainless steel should be specified for protection against corrosion. Stainless steel shall be low in carbon and stabilized with columbium or titanium to facilitate welding and to retain corrosion resistance after welding. Metallic waterstops are fabricated to specifications only when required for individual projects and structures. The thickness of a metallic waterstop represents a compromise between flexibility and susceptibility to damage rather than hydrostatic pressure considerations. Nonmetallic waterstops which include butyl rubber, neoprene, polyvinyl chloride, butadiene rubber, and natural rubber are specially shaped to permit a mechanical interlock between the concrete and the waterstop. The rubber waterstops possess high extensibility and high resistance to water and most chemicals and may also be formulated for fast recovery and fatigue resistant. Although the polyvinyl chloride waterstop is not as elastic as rubber, slower in recovery, and more susceptible to oils and some chemicals, it is still the most prevalent of the nonmetallic type. Being thermoplastic, PVC waterstops provide the great advantage of easily being spliced onsite and configured for intersections and directional changes of the joint. Specifications for materials used as waterstops will conform to those set forth in Civil Works Construction Guide Specification CW-03150, which cites CRD-C 513 for rubber and CRD-C 572<sup>1</sup> for polyvinyl chloride waterstops.

(1) Nonmetallic waterstops are manufactured in a wide variety of shapes as illustrated in Figure 3-1. The four most commonly used are the following:

(a) Flat waterstops normally have several rows of ribs along the length of the flanges to provide a better mechanical bond or interlock in the concrete.

(b) Dumbbell-shaped waterstops have solid-core bulbs along the two lengthwise edges to provide a better mechanical bond or interlock in the concrete. These dumbbells also serve as a mechanical seal to resist the flow of water or waterborne materials when embedded in the concrete. The flat waterstop is also available in a split configuration for forming considerations. With the split waterstops, the forms do not require openings for the waterstops to protrude through and are glued back together after removing the forms.

<sup>1</sup> Test methods cited in this manner are from the *Handbook of Concrete and Cement* (U.S. Army Engineer Waterways Experiment Station (USAEWES) 1949).

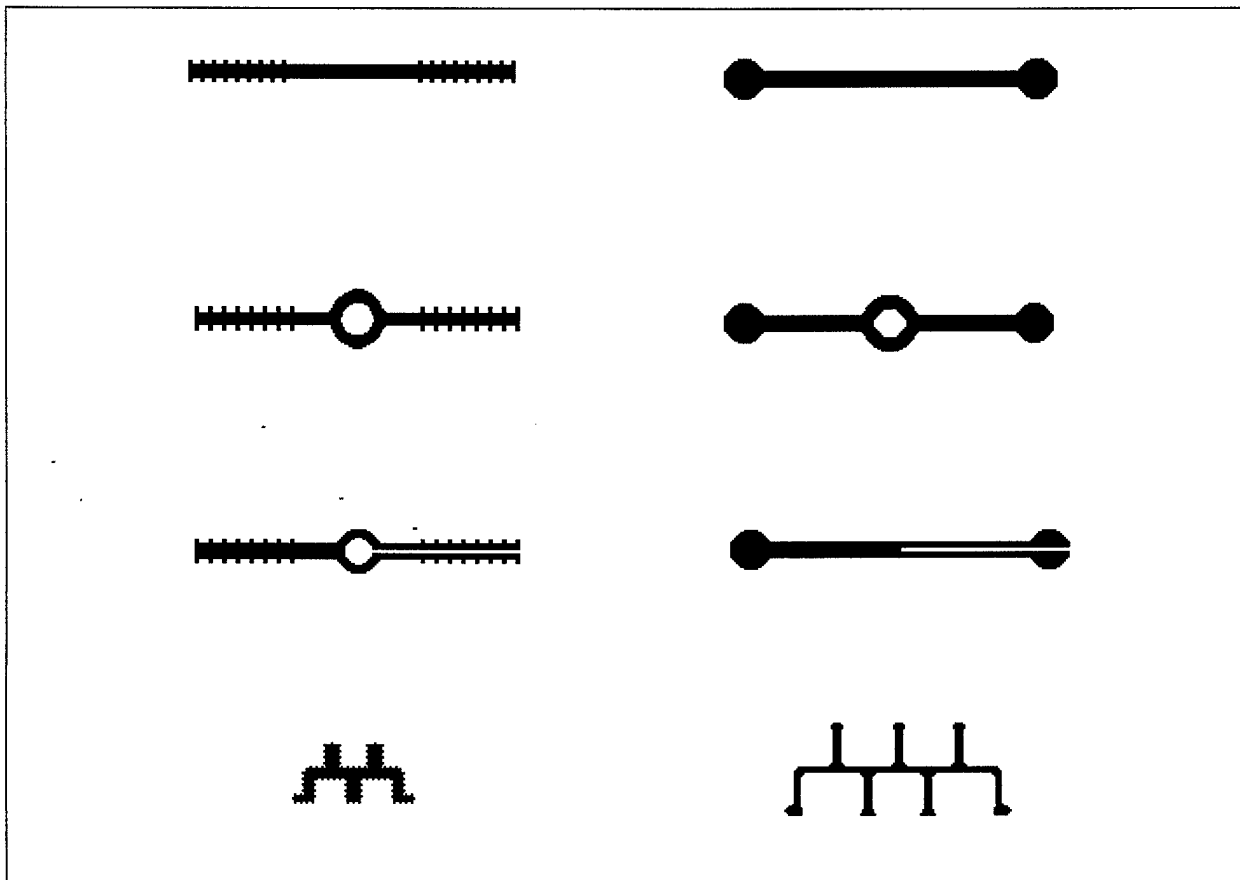

Figure 3-1. Various types and shapes of nonmetallic waterstops

(c) Centerbulb waterstops may be in combination with the flat or the dumbbell-shaped configuration for greater versatility. The centerbulb is hollow, allowing for a wider range of movement in the transverse, lateral, or shear directions and also provides for a greater amount of movement without excessively stretching the material. The split waterstop configuration is also available in the centerbulb type.

(d) Labyrinth-shaped waterstops are shaped to lie within nonmoving joints and not through the joint. They usually have numerous rows of ribs on all the surfaces for greater bond and seal in the concrete; others have bulbs similar to the dumbbell concept.

(2) Dimensional and size requirements of waterstops depend on the joint, its location, hydrostatic pressure, and the amount of movement expected. Most of the basic-shaped nonmetallic waterstops are available as an off-the-shelf item from numerous manufacturers and suppliers.

Nonmetallic waterstops are fabricated to specifications and to specific applications and not particularly to individual projects or structures. Table 3-1 lists the four basic shapes of nonmetallic waterstops and their nominal stock dimensions. Nonroutine and unique-shaped waterstops for special applications require special fabrication processes and dies.

*d. Applications.* Waterstops are used in containers or reservoirs that may be subjected to fluid pressure. Structures may be of a fluid retaining or fluid excluding nature. These include dams, locks, floodwalls, tanks, canal linings, pipelines, swimming pools, floors and walls of underground structures, and any concrete structure possessing contraction and expansion joints.

(1) The most common application of metallic waterstops is the use of flat steel waterstops in the horizontal joints of intake structures, because of the minimal movement in these joints.



**Table 3-1**  
**Shapes and Dimensions of Stock Nonmetallic Waterstops**

| Shape          | Waterstop Flange Thickness         | Overall Waterstop Width              | Bulb Diameter                    |
|----------------|------------------------------------|--------------------------------------|----------------------------------|
| (a) Flat       | 3.2 to 12.5 mm<br>(1/8 to 1/2 in.) | 100 to 225 mm<br>(4 to 9 in.)        |                                  |
| (b) Dumbbell   | 4.7 to 9.5 mm<br>(3/16 to 3/8 in.) | 100 to 300 mm<br>(4 to 12 in.)       | 9.5 to 25 mm<br>(3/8 to 1 in.)   |
| (c) Centerbulb | 3.2 to 12.5 mm<br>(1/8 to 1/2 in.) | 100 to 300 mm<br>(4 to 12 in.)       | 6 to 70 mm<br>(1/4 to 2-3/4 in.) |
| (d) Labyrinth  | 4.7 to 6.3 mm<br>(3/16 to 1/4 in.) | 82 to 156 mm<br>(3-1/4 to 6-1/4 in.) |                                  |

(2) Nonmetallic waterstops are generally used across an open expansion or contraction joint where a predetermined amount of movement is expected. Flat waterstops may be used in joints where very little lateral movement is expected. Dumbbell-shaped waterstops are also used in joints where small amounts of lateral movement is anticipated. The centerbulb-type waterstop is a universal type of waterstop and may be applied in both expansion and contraction joints where significant amounts of lateral as well as transverse movements is predicted. The labyrinth-shaped waterstop may be used under certain conditions where very little if any differential joint movement will occur and under very little hydrostatic pressures.

(3) Nonmetallic waterstops, especially PVC waterstops, are easily spliced to form different configurations. These configurations allow the waterstops to be placed in a variety of positions, such as around corners, at the intersection of complex construction, around columns, and other situations. Many manufacturers supply the difficult and special configurations as premade splices, which allows the contractor to perform the simple butt splice. The butt splice is much easier to perform than are the 'L', 'T', or the '+' splices. The butt splice is the butting together the ends of the same type waterstop in alignment with bulbs, flanges, and ribs. The butting ends are melted with a heating device and simply butted together. Upon cooling, the splice should be cleaned of excess material and inspected for bubbles, cracks, voids, misalignment, and burned material in the spliced area.

*e. Construction.* Waterstops are embedded in the concrete. Unlike most joint sealants that require installation after construction, waterstops are placed in the forms prior to concreting. The concrete is placed in the

form and is molded to conform to the shape of the waterstop.

(1) Metallic waterstops form an adhesive bond between the metallic waterstop material and the concrete. The superior strength of flat steel waterstop over other metallic types provides resistance to the increased potential for damage during waterstop installation and subsequent construction operations during placement of the next concrete lift. A typical installation would use a steel plate 200 to 225 mm (8 to 9 in.) wide and 3 to 4.7 mm (1/8- to 3/16-in.) thick.

(2) However, with nonmetallic waterstops that are made from rubber or polyvinyl chloride materials, a mechanical bond or interlock is formed with the ribs or bulbs of the waterstop rather than a chemical or adhesive bond. Currently, special repair techniques are being investigated that allow waterstops to be installed in hardened concrete. (See section 8-2 of EM 1110-2-2002 for current methods of repair of waterstop failures).

(3) Waterstops shall be stored in areas protected from the environment, dirt, oils, chemicals, debris, and physical damage. The waterstop shall be protected during handling, installation, and fabrication of splices. Damaged waterstops shall be removed from service and properly disposed of. All nonmetallic and flexible metallic waterstops shall be uncoiled approximately 24 hr prior to installation or splicing.

*f. Installation.* Metallic waterstops are securely installed in the formwork prior to concreting. Special care in handling is required for all waterstops to avoid tearing or bending the material. Waterstops are installed

in, through, and in some situations against the formwork as in the case of the nonmetallic split waterstop. Non-metallic dumbbell- and centerbulb-type waterstops are available in a split configuration as shown in Figure 3-1. Split configuration waterstops provide for easier installation into forms and much easier erection of the forms as shown in Figure 3-2. One flange of the split waterstop is split to allow the flange to open and be fastened flush to the inside of the formwork; this eliminates the use of split formwork, which is considered difficult to construct. With split formwork, the installation technique requires the form to be open, thus allowing insertion of the waterstop through the form. The exercise of particular care in the installation of waterstops in accordance with the provisions set forth in Civil Works Guide Specification CW-03150 should be emphasized. Adequate support against displacement, especially when placing large nominal maximum-size aggregate concrete, should be stressed to ensure correct positioning and embedment of waterstops. The exposed waterstop shall be cleaned of laitance,

form oil, dirt, and excess concrete prior to the second placement.

### 3-3. Preformed Compression Seals

*a. General.* Preformed compression seals are a form of preformed joint material that are compartmentalized or cellular in its internal structure. The preformed compression seal functions as a joint material when compressed and installed between two concrete surfaces or two armored concrete surfaces as in pavements and bridge decks. The preformed compression seal is designed with the compressible cellular structure as shown in Figure 3-3 to be compressed and inserted into a preexisting joint. The introduction of joints in a concrete structure creates openings which must be sealed to prevent the intrusion or passage of water, hard particles such as sand particles and trash, or unwanted substances such as jet fuels and other chemicals into the joint.

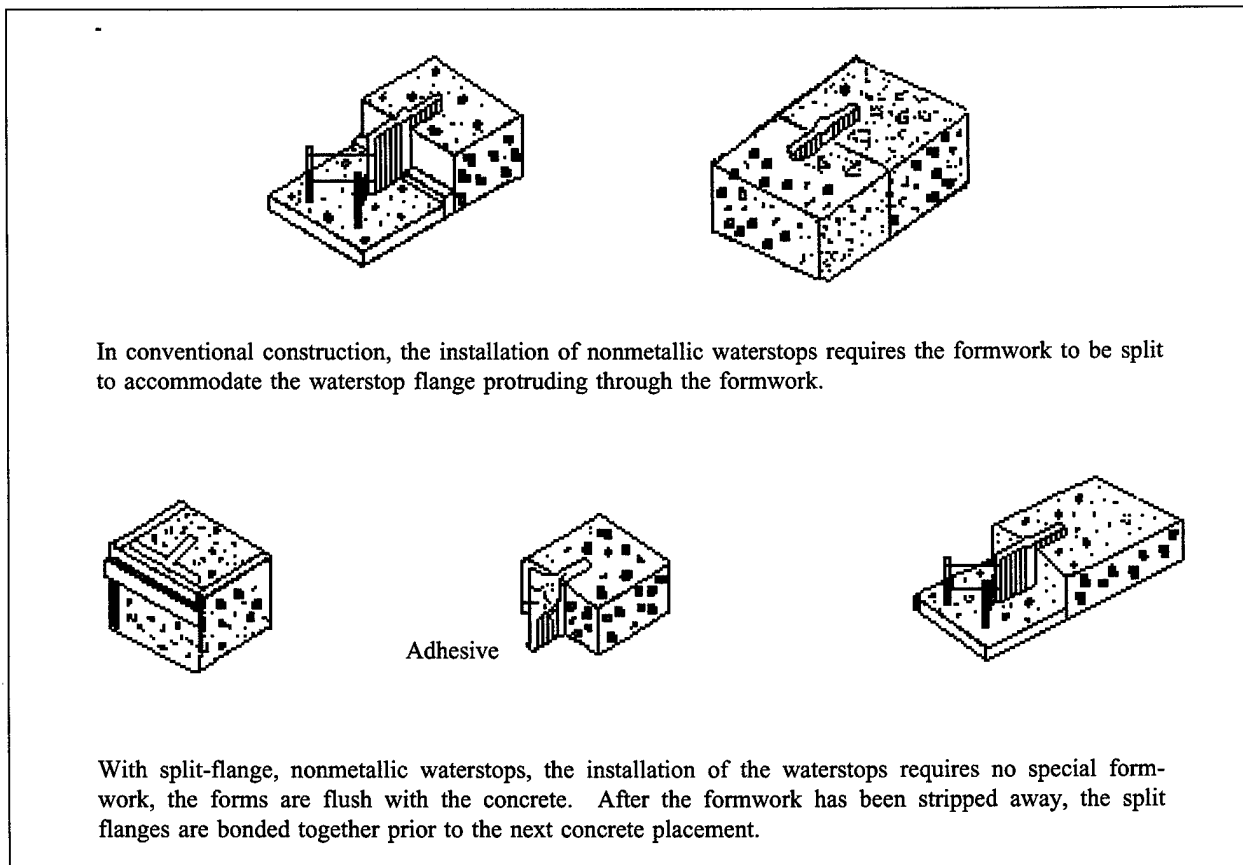
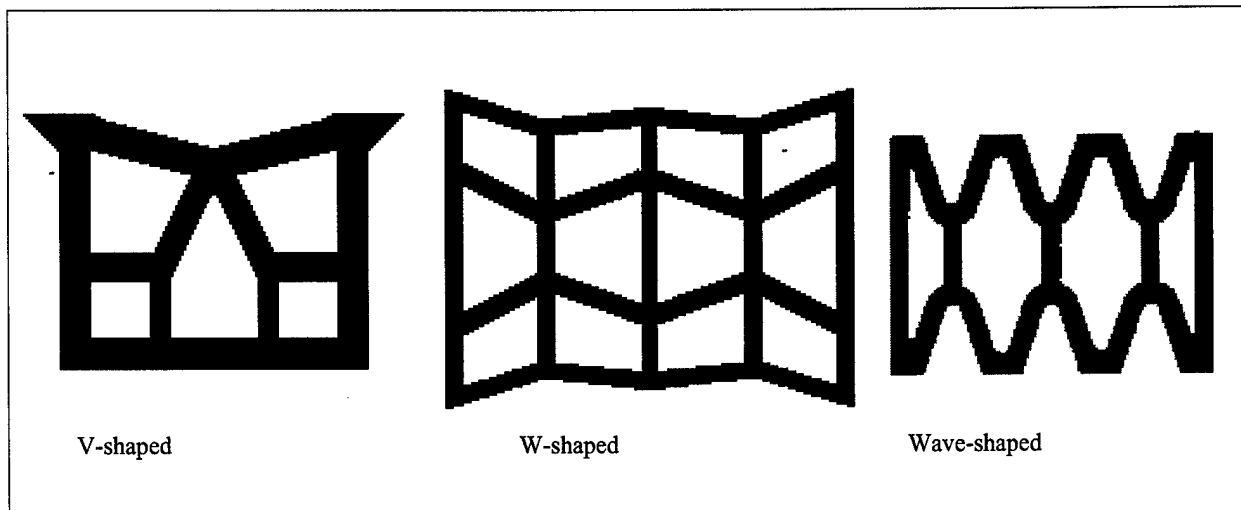

Figure 3-2. Nonmetallic waterstops may be installed by the split form method or by using split-flange waterstops



**Figure 3-3. Preformed compression seals are compartmentalized in their internal structure for compressible behavior. Shown are three of the several types and shapes of preformed compression seals available as stock materials**

*b. Materials.* Preformed compression seals are elongated units that have been extruded and vulcanized from neoprene and polychloroprene rubber compounds and polyurethane. These elastomeric compounds provide high resistance to ozone deterioration, resistance to fuel and oil, quick recovery from high and low temperatures, and great flexibility. The effective sealing of joints is more complex than merely filling a gap with a flexible, low-permeability material. Preformed compression seals require a lubricant for installation. The lubricant also acts as an adhesive in bonding the compression seals to the walls of the joints.

*c. Types.* The preformed compression seal is the most common of the preformed sealants. Basically, there are two main types of preformed joint sealants: the compression seal and the tension-compression seal. As implied by the group names, the compression seals are always in compression as shown in Figure 3-4 and the tension-compression seals may be in compression or tension when they are in a working joint. Compression-seal manufacturers produce generally three basic shapes of the preformed sealants. The internal webbing of the three shapes are similar, but the top surface of the preformed sealant are different. The most common surface is the 'V' shaped; it also has the widest range of sizes. The other two surfaces are the 'W' shape and the wave shape (Table 3-2).

*d. Function.* The shape of the joint and the anticipated movement, as well as the physical properties of the joint material, must be considered. The preformed

compression seals must also protect against the adverse effects of severe and cyclical weather while preserving the ability of the joint to function as designed. In most concrete structures, whether hydraulic or nonhydraulic, the concrete-to-concrete joint, such as an expansion or contraction joint, must be sealed to prevent damage to the joints. Construction joints are an exception in the use of preformed compression seals. To perform satisfactorily, the preformed compression seal must have certain basic properties:

The preformed compression seal must:

- (a) have adequately low permeability,
- (b) be flexible to deform to accommodate the range of movement,
- (c) be able to recover to its original shape and retain its properties,
- (d) remain in contact with joint faces at all times,
- (e) be durable internally throughout its webbing design,
- (f) remain firm and stable at high temperatures,
- (g) remain flexible and soft at low temperatures,
- (h) resist the affects of aging, weathering, and other environmental conditions, and

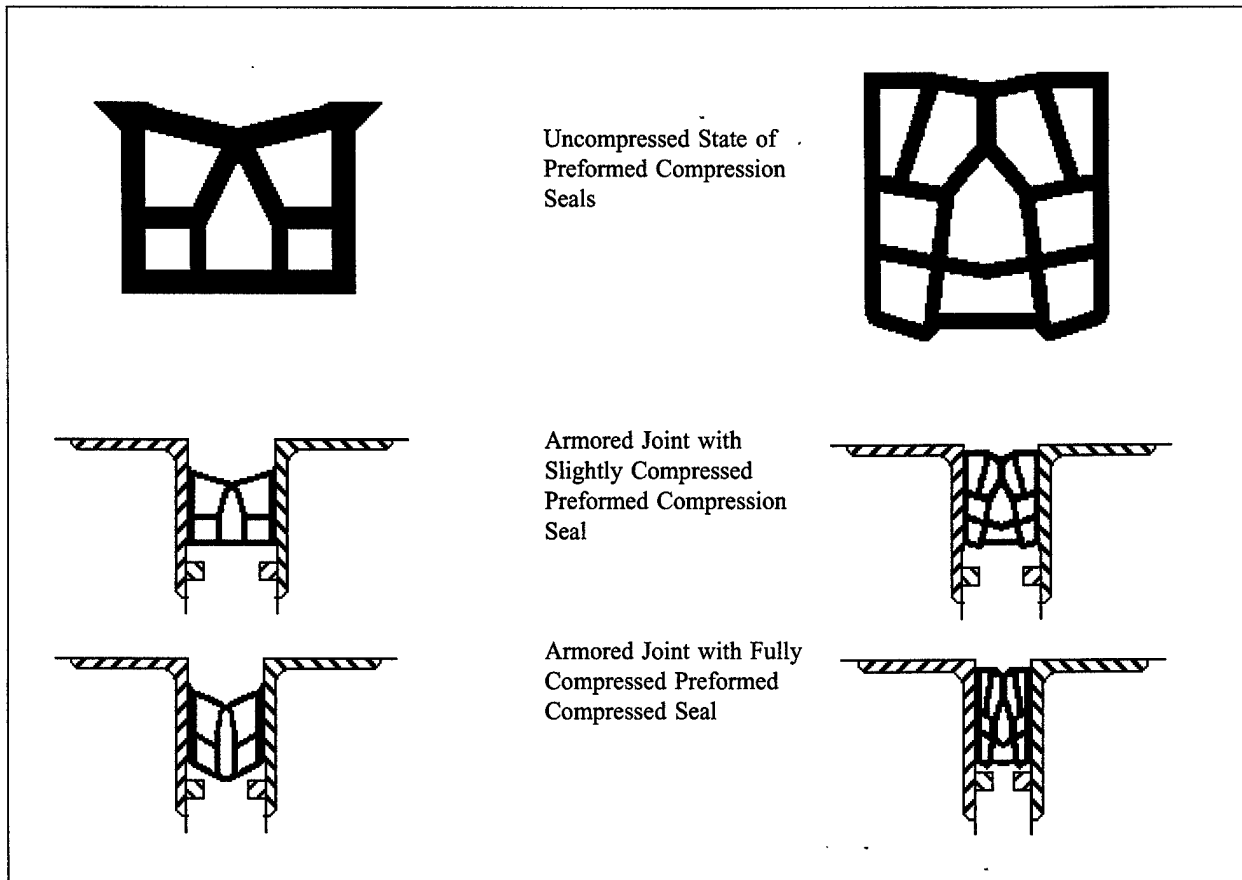

Figure 3-4. Preformed compression seals are compressed and inserted into the joint and remain in a compressed state. As the concrete expands and contracts, the compression seals remain in the compressed state

Table 3-2  
Dimensions of Stock Compression Seals

| Shape of Top | Nominal Width                      | Nominal Height                         | Max. Movement                        |
|--------------|------------------------------------|--|--------------------------------------|
| (a) V        | 8 to 150 mm<br>(5/16 to 6 in.)     | 16 to 141 mm<br>(5/8 to 5-5/8 in.)     | 3.5 to 82.5 mm<br>(0.14 to 3.25 in.) |
| (b) W        | 31.5 to 150 mm<br>(1-1/4 to 6 in.) | 31.5 to 141 mm<br>(1-1/4 to 5-5/8 in.) | 12.5 to 75 mm<br>(0.5 to 3 in.)      |
| (c) Wave     | 50 to 150 mm<br>(2 to 6 in.)       | 37.5 to 90 mm<br>(1-1/2 to 3-1/2 in.)  | 18 to 75 mm<br>(0.7 to 3 in.)        |

- (i) be resistant to chemicals, oils, and fuels.

The references to high and low temperatures given above reflect the actual temperature of the concrete surface being joined or sealed by the joint material which in turn determines the magnitude of joint movements and

consequent joint material performance. This range may vary from the ambient up to 66 °C (150 °F) where concrete is in constant contact with a material having a rapid temperature change rate, down to a very small range in structures below ground or underwater.

*e. Application.* Preformed compression seals are used in all types of structures, those under a slight fluid pressure and those that are not under any fluid pressure but require hard particles to be prevented from entering or passing through the joints. These include buildings, bridge decks, storage bins, retaining walls, roof decks, walkways, highways, airfield, floors, walls, and tunnels. They also include fluid retaining and excluding structures, but mostly low fluid pressure structures.

*f. Construction.* Preformed compression seals may be used in repair work as well as in new construction. New structures may be constructed with prepositioned joints cast in place or the structure may be cast monolithically and cut or sawed in specified intervals or locations for installing joint sealants. Repair techniques may warrant replacing deteriorated joint material or it may be required to correct a deficiency in the concrete such as cracks. The cracks may have opened to relieve the concrete from internal stresses. These cracks may be converted to joints by cutting or sawing through the crack, cleaning and removing the deteriorated concrete, and repairing the surfaces of the joint to a specified width and depth. The joint must be uniform in width, straight, smooth, and clean to provide uniform contact to both surfaces.

*g. Installation.* Preformed compression seals may be installed in preexisting joints by several methods ranging from manual installation to fully automated systems that lubricate the sealant as it installs the compression seal into the joint. The manual procedure requires compressing the preformed compression seal to a width slightly narrower than the joint opening and exerting pressure along the outer edge of the compression seal to insert the joint material into the opening. Other manual procedures require special tools for alignment and exerting pressure both laterally and longitudinally along the compression seal. The special tools are primarily for larger and wider preformed compression seals that require more force and pressure to compress the joint material. The automated units are primarily for pavements. All installation methods, procedures, and equipment require the use of a lubricant or an adhesive to properly install the preformed compression seal. The lubricant facilitates the installation of the joint material into the joint and the adhesive bonds the joint material to the walls of the joint.

### 3.4 Miscellaneous Sealants

*a. General.* There are a number of other preformed joint materials used in hydraulic and nonhydraulic structures. These include tension-compression seals, gate

seals, gaskets, and tapes. The tension-compression seals are used in similar conditions as the strict compression seal in pavements and bridge decks, except the design incorporates steel plates and fixed anchorages to support heavy loads and traffic on the bearing surface. The gate seals are used in hydraulic structures as a means of sealing the flow of water through the joints around gates and bulkheads including: vertical lift, tainter, head, flood, spillway, sluice, emergency, service, slide, caterpillar, wheel, sector, and miter gates. Gaskets and tapes are used primarily in pipes and walls.

*b. Tension-compression seals.* Tension-compression seals are designed for heavy traffic areas where considerable movement is anticipated. These joint materials consist of flexible elastomeric materials with steel bearing plates encased in the material to increase the durability of the seal in traffic. Other designs of tension-compression seals incorporate the steel plates onto the riding surface of the sealant to significantly increase the wear resistance caused by heavy traffic, studded tires, snowplowing, and abrasives. The tension-compression seals are anchored to the concrete faces to provide the tensile component of the joint material. Grooves are formed in the sealants to permit greater changes in joint movements, up to 330 mm (13 in.) in some bridge decks.

*c. Gate seals.* Gate seals are used to stop leakage at the joint area between the gate and the sill. Gate seals are designed with numerous shapes for different applications. The two most commonly used are the 'J' and 'L' types as described by several manufacturers. Gate seals are made of rubber because of its ability to form a tight seal on contact with any reasonably smooth surface. The gate seals are mounted to the upstream side of the gates; this allows the water pressure to increase the contact pressure of the seal to the gate. However, with the gates in the open position, the gate seals must be securely fastened to prevent water from flowing underneath them. Placement details must be carefully worked out to prevent excessive wear of the rubber gate seal during normal usage. Only very light contact is needed between the gate seal and the sill when there is a no water load contact, otherwise excessive wear could result in those dry situations. The gate seal may be spliced at the transition from side seals to bottom seals.

*d. Gaskets and tapes.* In nonhydraulic situations, wall joints may be sealed using gaskets and tapes. Gaskets are also used in joints between pipes and service lines. Gaskets and tapes generally are composed of rubber or polyvinyl chloride. Their sealing action is obtained by compressing the joint material between the joint faces

**EM 1110-2-2102**  
**30 Sep 95**

similar to the compression seals or because of the pressure sensitive nature of some butyl compounds, the joint material adheres to the surface of the joint.

## Chapter 4 Design

### 4-1. Waterstops

*a. General.* Waterstops are designed for hydraulic structures to withstand continuous water pressures for the life expectancy of the structure or for cyclic water levels and pressures in floodwalls and locks. Factors affecting design dimensions of metallic waterstops are largely traditional, stemming from experience rather than computation. The selection of nonmetallic waterstops is predicated to a great extent on hydrostatic considerations.

(1) Figure 4-1 shows the relation of material thickness and width requirements of polyvinyl chloride waterstops versus the height of hydrostatic head. For example in the graph, a concrete dam or lock that is designed to resist a 300,000-Pa (100 ft of water) head of hydrostatic pressure may require a PVC waterstop that is 250 mm (10 in.) wide and only 4 mm (0.16 in.) thick, whereas an 8-mm (0.32-in.)-thick PVC waterstop need only be 100 mm (4 in.) wide as shown in Figure 4-2. A wide range of PVC waterstop dimensions may be used to resist a single head pressure. This relationship represents an average value of hydrostatic pressure ratings for various sizes of PVC waterstops and is therefore relatively insensitive to small, subtle variations in the configuration of each individual waterstop. Thus, the graph is only valid for use as general guidance in the design and selection of PVC waterstops. Additional data concerning the material properties of PVC waterstops are presented by Hoff and Houston (1970).

(2) Certain waterstop sizes are used much more often than others. Whether through reference to previous designs or to peer usage, designers primarily specify 150-mm (6-in.) and 225-mm (9-in.)-wide waterstops. Thus, production, availability, and usage have become a self-perpetuating cycle in the design requirements of non-metallic waterstops.

*b. Conventional design considerations.* Design engineers must consider several factors in selecting waterstop materials for possible use in their projects. Hydraulic structures require waterstops in all moving and non-moving joints. The lateral movement anticipated for a joint wall determines the types of waterstop to be selected. The vertical movement anticipated for a joint will determine the shapes of the waterstop to be selected. The anticipated hydrostatic head of water will determine the thicknesses and the widths of the waterstop to be

selected. The anticipated allowable water migration for a joint will determine both the types and shapes of the waterstop to be selected. The anticipated size of the joint opening will determine the configurations or profiles of the waterstop to be selected. Every structure and project is different and will be designed for their respective requirements.

*c. Unconventional design considerations.* Design engineers will consider several other factors in selecting waterstop materials for use in their structure. The performance of waterstop materials is affected by factors prior to their use in a concrete structure. The anticipated exposure of the waterstop material at a project prior to the time both edges are embedded in the concrete will affect the determination of selecting the thicknesses and widths of the waterstops. The anticipated types of materials handling procedures and techniques at a project will affect the determination of waterstop selection. Many materials may become worn, fatigued, or damaged from excessive handling and exposure to the environmental elements during construction. Rubber materials are more susceptible to ozone exposure than others. Polyvinyl chloride materials as well as rubber materials are susceptible to oils, solvents, and other chemicals.

### 4-2. Preformed Joint Seals

*a. General.* Preformed compression seals are designed primarily for nonhydraulic structures to prevent the introduction of unwanted and harmful particles from entering the joint and causing excessive compressional forces to be applied to the concrete surfaces during periods of expansion. It is the variation in joint conditions and joint material properties which influence the selection of one joint material over another. The compression seal is designed to be compressed and inserted into designed expansion and contraction joints of hardened concrete and remain in a compressed state throughout its life in the joint. Although preformed compression seals are installed with lubricant/adhesive for easy installation and bonding to the concrete surfaces, they are not designed to resist tensile forces, therefore the designer must be aware of the anticipated contraction that may occur in the concrete structure and particularly in the structural element. Preformed compression seals should always be compressed to a minimum of 15 percent of the material width. With the preformed compression seal always in compression, the sealant will change its shape as the width of the joint opening changes, therefore the designer must also be aware of the depth of the joint to allow the joint material to flex, normally downward into the joint.

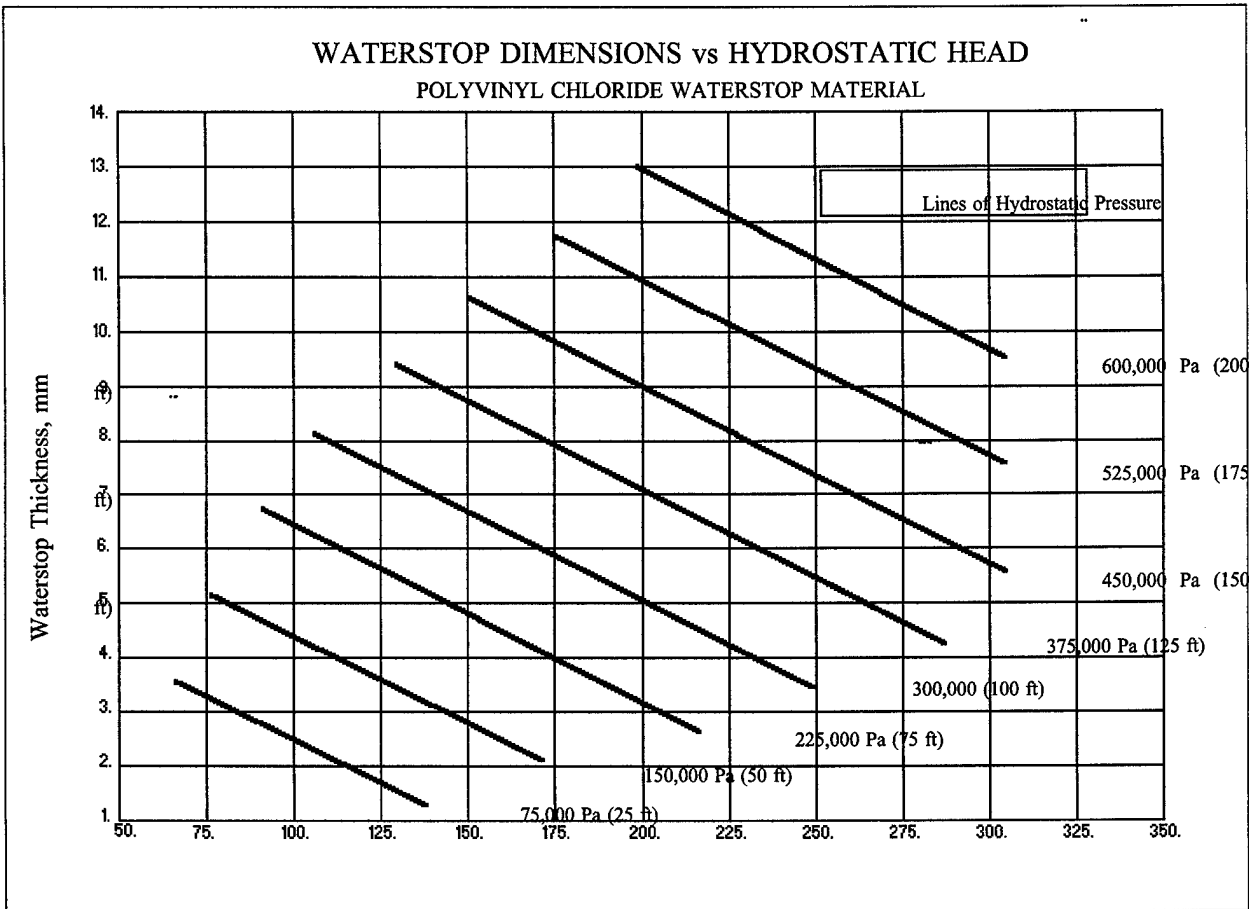

Figure 4-1. This graph shows the general relationship between polyvinyl chloride waterstop dimensions to the hydrostatic head pressure of water

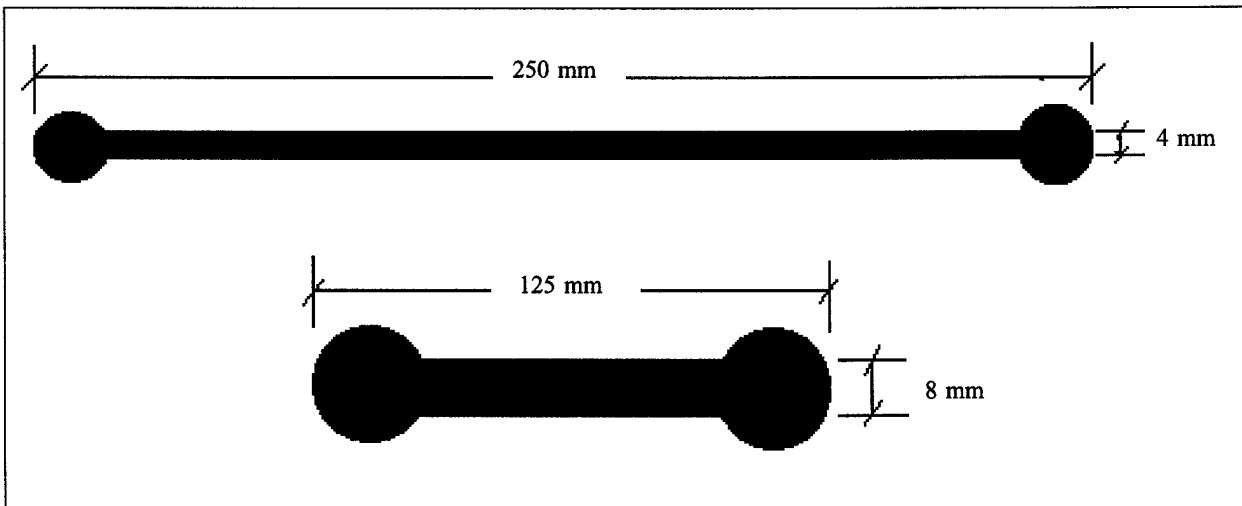

Figure 4-2. These two polyvinyl chloride waterstops of different dimensions may be used under identical 300,000-Pa (100 ft of water) hydrostatic head pressures as depicted in the graph shown in Figure 4-1



(1) Joint Dimensions for Preformed Compression Seals. These seals have a variety of different dimensions in width and height to cover a broad range of joint dimensions. The characteristics of the joint opening dictates the characteristics of the joint material to be specified. The initial dimensions of the joint opening, width and depth, plus the anticipated movement expected in the joint opening, narrowest to widest, from temperature variations and internal and external stresses applied to the concrete, specifies the characteristics of the joint opening. The general rule of thumb for the maximum amount of vertical movement of pavements and slabs within the joint opening is that it should not exceed 6 mm (1/4 in.).

(2) Preformed Compression-Seal Dimensions. Preformed compression seals are available in dozens of sizes and dimensions. The preformed compression seals may range in size dimensions from 8-mm (5/16-in.) widths and 16-mm (5/8-in.) heights to 150-mm (6-in.) widths and 140-mm (5.5-in.) heights. The preformed compression seals also have a wide variety of wall thicknesses and internal geometric designs and arrangements. In determining the correct compression seal for each individual project, the compression seal must be maintained in a

compressed state at all times but not less than approximately 15-percent compression and the compression seal must also allow for approximately 40-percent joint movement based upon the uncompressed width of the compression seal (see Figure 4-3).

*b. Design criteria.* Design engineers must consider several factors in selecting preformed joint sealants and other joint materials for possible use. The anticipated movement, expansion, and contraction in a joint will determine the types of preformed joint material to be considered. The anticipated joint dimensions will determine the types and sizes of preformed joint material to be considered.

*c. Material consideration.* Design engineers must select the preformed joint material based on the joint dimensions, its width, depth, and length. The joint dimensions will determine the type and nominal size of the preformed joint material as designated by the manufacturers. The material consideration will also include the amount of lateral movement that may be anticipated during all applications, environmental conditions, and loadings. The anticipated joint movement will determine

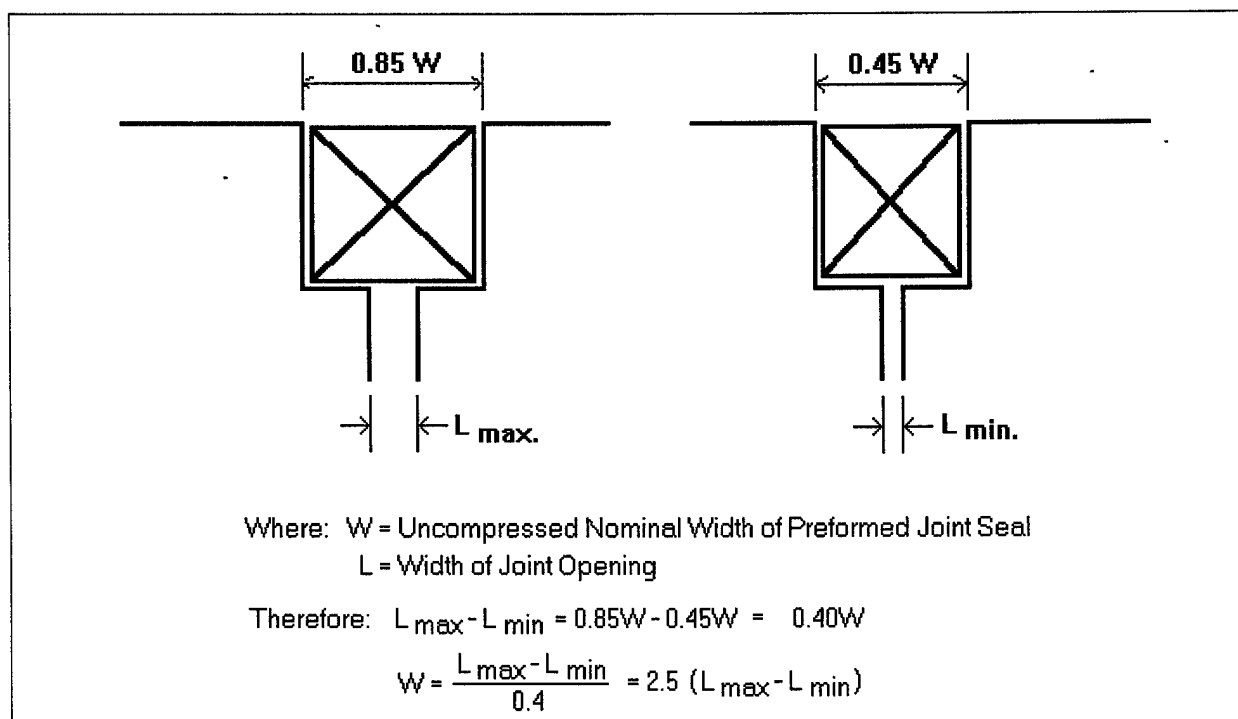

Figure 4-3. Determination of minimum size of compression seal

**EM 1110-2-2102**  
**30 Sep 95**

the type and nominal size of the preformed joint material required for the application. Many preformed joint materials such as compression seals are designed to be in a

minimum of 15-percent compression at all times, therefore the designers must anticipate for the maximum movement as well as the minimum joint opening for that joint.

## Chapter 5 Sampling

### 5-1. General

The materials covered by this manual will be sampled lot by lot for acceptance. The manufacturer or supplier submits a product to the contractor in groups or lots which are accepted or rejected in their entirety on the basis of the performance of the samples taken from that lot. The manufacturing lot is considered the material produced under the same conditions such as single batch of raw materials, single production line, single production method, single production shift, and under a single curing period. The material may be sampled at the place of manufacture, at the point of delivery, or at the project site.

### 5-2. Material

All samples of waterstops and other preformed joint materials shall be submitted to CEWES-SC-EM<sup>1</sup> for determination of compliance with their respective specification requirements. The samples of materials must be representative of the material to be used in the construction project. The quantity of material necessary to conduct the required number of tests for determining compliance of the material to meet specification requirements will be sampled.

#### a. Waterstops.

(1) Metallic waterstops. Steel, stainless steel, copper, lead, bronze, and other metallic waterstops will be sampled and tested in accordance with their respective requirements. Generally, each material shall be sampled with sufficient material to produce a minimum of five test specimens for each test procedure required.

(2) Nonmetallic waterstops. Polyvinyl chloride and rubber waterstops will be sampled and tested in accordance with the requirements of CRD-C 572 and CRD-C 513, respectively. Nonmetallic waterstops are manufactured in lots or runs for a specified period of time or type or size of material needed to maintain supply by the manufacturers. Generally, each manufacturing lot or run shall be sampled with a minimum of 1 m (4 ft) of finished waterstop and each 61 m (200 ft) required for the project shall be sampled with a minimum of 300 mm (1 ft) of

<sup>1</sup> See paragraphs 5-6.

finished waterstop. The 1-m (4-ft) sample shall be evaluated to determine compliance of the waterstop material to the specification requirements. Each of the 300-mm (1-ft) samples shall be evaluated to determine continuity of the waterstop throughout the manufacturing lot or run for the project. All tests will be performed on test specimens prepared from randomly taken samples representing the manufacturing lot or run.

b. *Preformed joint materials.* Preformed joint materials will be sampled in accordance with the requirements of CRD-C 531 (ASTM D 2628)<sup>2</sup> and CRD-C 547. In general, each manufacturing lot of lineal joint material will be sampled with a minimum of 3 m (9 ft) of preformed joint material.

c. *Miscellaneous joint materials.* Preformed elastomeric gaskets and joint materials shall be sampled in accordance with the requirements of CRD-C 549 (ASTM C 509). Preformed joint materials of the nonlinear (such as gaskets and tapes) nature that do not lend themselves to testing because of their complicated shapes, size, or component nature will be sampled for each particular project.

d. *Lubricants for installing preformed joint material.* The lubricant used in installing preformed joint materials will be sampled in accordance with the requirements of CRD-C 532 (ASTM D 2835). In general, the 1-L (1-qt) aliquot sample shall consist of a composite from three or more randomly chosen containers.

### 5-3. Sampling at the Manufacturer

When samples are to be taken at the manufacturing plant, the purchaser shall be notified by the contractor, supplier, or the manufacturer prior to sampling to allow arrangement for inspection and sampling. Upon obtaining each sample, the sample will be identified by lot number, specific location within the manufacturing lot where the sample was taken, date sampled, and name of the person conducting the sampling. The samples plus appropriate documentation indicating the Project, District, Contract Number, and Point of Contact, shall be sent to the laboratory.

<sup>2</sup> Test methods cited in this manner are from the *Handbook of Concrete and Cement* (USAEWES 1949) and the American Society for Testing and Materials (ASTM) *Annual Book of ASTM Standards* (current edition), respectively.

**5-4. Sampling at the Project Site**

When samples are to be taken at the project site, the Project Engineer will be notified by the contractor prior to sampling to allow inspectors to observe the sampling procedure. Each sample will be uniquely identified by lot number, location within the lot of the material on site, date sampled, and the name of the person conducting the sampling. The samples, plus appropriate documentation of Project, District, Contract Number, and Point of Contact, will be sent to the laboratory.

**5-5. Retest Samples**

When the results of tests on the initial samples fail to comply with the project specifications, the Government

may request the contractor to submit additional samples from the same manufacturing lot or new samples from another manufacturing lot, in which case the Government inspector will be present to observe the sampling.

**5-6. Laboratory**

All waterstops and other preformed joint materials shall be sent to the U.S. Army Engineer Waterways Experiment Station, ATTN: CEWES-SC-EM, 3909 Halls Ferry Road, Vicksburg, Mississippi, 39180-6199.

## Chapter 6 Quality Assurance Testing and Specifications

### 6-1. General

All waterstops and other preformed joint materials will be tested for compliance with the applicable specifications prior to their use. Any material failing to comply with their respective specification requirements will be rejected as a manufacturing lot or run, acceptance and rejection will only be based upon a full evaluation.

### 6-2. Testing

Samples of all waterstops will be sent to the testing laboratories as described in Section 5-6.

*a. Metallic waterstops.* All metallic waterstops will be tested and evaluated for chemical composition and relevant mechanical properties such as tensile strength, elongation, hardness, and bending.

*b. Nonmetallic waterstops.* Nonmetallic waterstops will be tested and evaluated as called for in CRD-C 513 or CRD-C 572 as appropriate.

*c. Preformed compression seals.* Preformed polychloroprene elastomeric joint seals will be tested and evaluated as called for in CRD-C 531.

*d. Gaskets and other sealing materials.* Gaskets and other sealing materials shall be tested and evaluated as called for in the applicable specifications.

*e. Lubricants.* Lubricants for installing preformed compression seals will be tested and evaluated as called for in CRD-C 532.

### 6-3. Specifications

*a. Metallic waterstops.* Copper waterstops are covered by Standard Specification for Copper Sheet, Strip, Plate, and Rolled Bar, CRD-C 546 (USAEWES 1949) (ASTM B 152) and Standard Specification for Copper Sheet and Strip for Building Construction, ASTM B 370.

Stainless steel waterstops are covered by Standard Specification for Stainless and Heat-Resisting Chromium-Nickel Steel Plate, Sheet, and Strip, ASTM A 167. Steel waterstops are covered by Standard Specification for Steel, Strip, Carbon, Cold-Rolled, ASTM A 109, or Standard Specification for Steel, Sheet and Strip, Carbon, Hot-Rolled, Structural Quality, ASTM A 570. Lead waterstops are covered by Standard Specification for Lead and Lead Alloy Strip, Sheet, and Plate Products, ASTM B 749. Bronze waterstops depending upon the alloys in the bronze material are covered by Standard Specifications for Aluminum Bronze Rod, Bar, and Shapes, ASTM B 150, Standard Specification for Aluminum Bronze Plate, Sheet, Strip, and Rolled Bar, ASTM B 169, Standard Specification for Phosphor Bronze Plate, Sheet, Strip, and Rolled Bar, ASTM B 103, or Standard Specification for Manganese Bronze Rod, Bar, and Shapes, ASTM B 138.

*b. Nonmetallic waterstops.* Rubber waterstops (butyl, neoprene, styrene butadiene, nitrile butadiene, polyisoprene, and natural) are covered by U.S. Army Corps of Engineers Specifications for Rubber Waterstops, CRD-C 513. Polyvinyl chloride waterstops are covered by Corps of Engineers Specifications for Polyvinyl chloride Waterstops, CRD-C 572. Factory and job-site made splices are covered by CRD-C 513 and CRD-C 572.

*c. Preformed joint materials.* Preformed compression seals for concrete pavements are covered by Standard Specification for Preformed Polychloroprene Elastomeric Joint Seals for Concrete Pavements, CRD-C 531 (ASTM D 2628) and Standard Specification for Jet-Fuel- and Heat-Resistant Preformed Polychloroprene Elastomeric Joint Seals for Rigid Pavements, CRD-C 548. Preformed compression and tension-compression seals for bridge decks are covered by Standard Specification for Preformed Polychloroprene Elastomeric Joint Seals for Bridges, ASTM D 3542. Preformed gaskets and joint sealing materials are covered by Standard Specification for Cellular Elastomeric Preformed Gasket and Sealing Material, CRD-C 549 (ASTM C 509).

*d. Lubricants.* The lubricants used in the installation of many preformed joint materials are covered by Standard Specification for Lubricant for Installation of Preformed Compressive Seals in Concrete Pavements, CRD-C 532 (ASTM D 2835).

## Appendix A References

### A-1. Corps of Engineers Publications

**EM 1110-2-2000**

Standard Practice for Concrete

**EM 1110-2-2002**

Evaluation and Repair of Concrete Structures

**EM 1110-2-2200**

Gravity Dam Design

**EM 1110-2-2400**

Structural Design of Spillway & Outlet Works

**EM 1110-2-2502**

Retaining and Flood Walls

**EM 1110-2-2602**

Planning & Design of Navigation Lock Walls & Appurtenances

**EM 1110-2-2701**

Vertical Lift Crest Gates

**EM 1110-2-2901**

Tunnels & Shafts in Rock

**EM 1110-2-2902**

Conduits, Culverts and Pipes

**CW 03150**

Expansion, Contraction, and Construction Joints in Concrete

**U.S. Army Engineer Waterways Experiment Station 1949**

U.S. Army Engineer Waterways Experiment Station. 1949. *Handbook for Concrete and Cement*, with quarterly supplements, Vicksburg, MS. Note: Use latest edition of all designations.

**Hoff and Houston 1970**

Hoff, G. C., and Houston, B. J. 1970 (Oct). "Non-metallic Waterstops," Miscellaneous Paper C-70-22, U.S. Army Engineer Waterways Experiment Station, Vicksburg, MS.

### A-2. Related Publications

**American Concrete Institute 1992.**

American Concrete Institute. 1992. "Guide to Joint Sealants for Concrete Structures," ACI Report No. 504 R-77, *ACI Manual of Concrete Practice*, Part 5, Detroit, MI.

**American Society for Testing and Materials, Current**

American Society for Testing and Materials. Current. *Annual Book of ASTM Standards*, Vol 01.01, 01.02, 01.03, 02.01, 02.02, 02.04, 04.02, 04.03, and 04.07, Philadelphia, PA

**Hoff and Houston 1973**

Hoff, G. C., and Houston, B. J. 1973. "Nonmetallic Waterstops," *ACI Journal*, pp 7-18.

## **Appendix B Definitions**

### **Compression Seal**

A compartmentalized or cellular sealant which by compression between the joint faces provides a seal.

### **Gasket**

A deformable material clamped between essentially stationary faces to prevent the passage of matter through an opening or joint.

### **Joint Filler**

A compressible material used to fill a joint to prevent the infiltration of debris and to provide support for sealants.

### **Joint Sealant**

A compressible material used to exclude water and solid foreign materials from joints.

### **Packing**

A deformable material used to prevent or control the passage of matter between surfaces which move in relation to each other.

### **Preformed Sealant**

A sealant functionally preshaped by the manufacturer so that only a minimum of field fabrication is required prior to installation.

### **Seal**

A generic term for any material or device that prevents or controls the passage of matter across the separable members of a mechanical assembly.

### **Sealant**

Any material used to seal joints or openings against the passage of solids, liquids, or gases.

### **Waterstop**

A thin sheet of metal, rubber, plastic, or other material inserted across a joint to obstruct the seeping of water through the joint.