

AFRL-SR-AR-TR-02-0179

AD-



**(New World Vistas)(Cooperative Agreement)  
Investigation of Basic Physics Processes  
In The Pasotron HPM Source**

F49620-99-2-0058



Prof. Carmel  
University of Maryland

20020614 168

Approved for public release; distribution unlimited

Air Force Research Laboratory  
Air Force Office of Scientific Research  
Arlington, Virginia

NE

**REPORT DOCUMENTATION PAGE**

AFRL-SR-AR-TR-02-

Public reporting burden for this collection of information is estimated to average 1 hour per response, including reviewing the collection of information, gathering and maintaining the data needed, and completing and reviewing the collection of information, including suggestions for reducing this burden, to Washington, DC 20503.

0179

existing data or any other variations and (0704-0189),

<b>1. AGENCY USE ONLY (Leave blank)</b>		<b>2. REPORT DATE</b>	<b>3. REPORT TYPE AND DATES COVERED</b> 15 Dec 98 to 29 Nov 01 FINAL	
<b>4. TITLE AND SUBTITLE</b> (New World Vistas) (Cooperative Agreement ) Investigation of Basic Physics Processes in the Pasotron HPM Source			<b>5. FUNDING NUMBERS</b> 61102F 2301/EX	
<b>6. AUTHOR(S)</b> Prof. Carmel				
<b>7. PERFORMING ORGANIZATION NAME(S) AND ADDRESS(ES)</b> Univeristy of Maryland 2100 Lee Building College Park, MD 20742			<b>8. PERFORMING ORGANIZATION REPORT NUMBER</b>	
<b>9. SPONSORING/MONITORING AGENCY NAME(S) AND ADDRESS(ES)</b> AFOSR/NE 801 North Randolph Street Rm 732 Arlington, VA 22203-1977			<b>10. SPONSORING/MONITORING AGENCY REPORT NUMBER</b>  F49620-99-2-0058	
<b>11. SUPPLEMENTARY NOTES</b>				
<b>12a. DISTRIBUTION AVAILABILITY STATEMENT</b> APPROVAL FOR PUBLIC RELEASED; DISTRIBUTION UNLIMITED			<b>12b. DISTRIBUTION CODE</b>	
<b>13. ABSTRACT (Maximum 200 words)</b>  The thrust of the joint UMD/HRL research program was to improve the understanding of physics issues in the operation of the pasotron, and to exploit this knowledge by improving the tube's performance. This study was extremely successful. The innovation of using a tailored-profile, plasma neutralized electron beam yielded an increase in the total pasotron efficiency 17% to -32%, and an electron efficiency of -40%. Moreover, our theoretical results indicate that the pasotron efficiency, after optimization, may be as high as 60-70%. Both theoretical and experimental results will be described below.				
<b>14. SUBJECT TERMS</b>			<b>15. NUMBER OF PAGES</b>	
			<b>16. PRICE CODE</b>	
<b>17. SECURITY CLASSIFICATION OF REPORT</b>  UNCLASSIFIED	<b>18. SECURITY CLASSIFICATION OF THIS PAGE</b>  UNCLASSIFIED	<b>19. SECURITY CLASSIFICATION OF ABSTRACT</b>  UNCLASSIFIED	<b>20. LIMITATION OF ABSTRACT</b>  UL	



**INVESTIGATION OF BASIC PHYSICS PROCESSES IN THE PASOTRON HPM  
SOURCE**

**AFOSR Grant Number F496209920058**

**FINAL**  
~~Progress~~ Report for the period 7/30/2000 to 10/30/2001

Submitted to

**Dr. R. Barker**  
**Air Force Office of Scientific Research**

Work performed jointly by

**Institute for Plasma Research**

**University of Maryland**

**College Park, MD 20742**

And

**D. Goebel, Boeing, EDD**  
**Torrance, CA**

**October 2001**

## 2. Summary of recent results (AFOSR Grant #F49620-99-20058, entitled "Investigation of Basic Physics Processes in the Pasotron HPM Source").

The thrust of the joint UMD/HRL research program was to improve the understanding of physics issues in the operation of the pasotron, and to exploit this knowledge by improving the tube's performance. This study was extremely successful. The innovation of using a tailored-profile, plasma neutralized electron beam yielded an increase in the total pasotron efficiency 17% to ~32%, and an electronic efficiency of ~40%. Moreover, our theoretical results indicate that the pasotron efficiency, after optimization, may be as high as 60-70%. Both theoretical and experimental results will be described below.

### 2.1 Summary of recent theoretical results

The theoretical studies were described in a series of papers<sup>1 2 3 4 5</sup>, two invited talks<sup>6 7</sup>, and two contributed talks<sup>8 9</sup> at international conferences. This activity can be subdivided into several topics:

*(a) Radiation of forward and backward waves in the absence of an external magnetic field*<sup>7,11,12</sup>.

In the absence of guiding magnetic fields, the electrons can move radially, being affected by the beam self-fields and by the radial component of the electric field of the wave. It was shown that this radial motion could improve the coupling of electrons to the field of a slow wave localized near the structure wall, and thus, enhance the efficiency. This radial motion can also cause an energy exchange between the electrons and the wave due to additional transverse interaction. This additional interaction, in particular, can lead to an experimentally observed<sup>10</sup> excitation of non-symmetric transverse electric waves in pasotrons.

*(b) Effect of a weak external magnetic field*<sup>8,12,13,14</sup>.

This study was devoted to the analysis of pasotron operation in the presence of a weak external magnetic field. It was assumed that the focusing effect of this field is of the same order as the defocusing effect of the radial electric field of the wave. Correspondingly, one may expect that, under certain conditions, the wave field will move electrons radially in the region of strong interaction with the wave, while the external magnetic field will keep electrons off the structure wall, thus avoiding the beam interception with the wall. The results showed that, for typical pasotron parameters, it is enough to apply the magnetic field smaller than 100 Gauss. Just such a small field allows one to increase the efficiency by a factor of 1.2 (e.g. from 30% to 37% or from 20% to 24%), and simultaneously to avoid the beam interception by the wall. This theoretical prediction was confirmed in the experiments (see ref. 8).

*(c) Theory of helix pasotron backward wave oscillator*<sup>10,14</sup>.

In this study a 3D analysis of the pasotron backward-wave oscillator (BWO) utilizing a helix slow-wave structure (SWS) was performed. Such a pasotron developed at Hughes Research Lab was used in the experiments at UMD, which will be described below. The dispersion characteristic of the helix and the interaction impedance of a beam with the

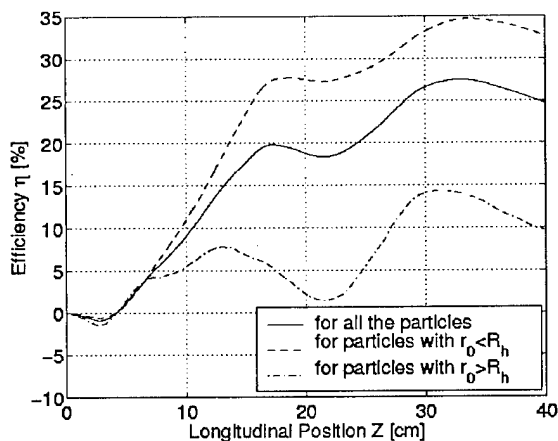

*Figure 1: Electron efficiency depends on their initial radial position in the beam. Electrons inside the helix have higher efficiency than those outside (see ref. 10 for parameters).*

SWS field were calculated by using the recently developed code CHRISTINE<sup>11</sup>. The results showed that, in accordance with the general conclusion made earlier<sup>7</sup>, the electrons injected inside the helix operate with higher efficiency than those electrons, which were injected outside. For the case when a helix of a radius 2.5 cm is installed in a cylindrical waveguide of a radius 5 cm and the injected beam has an initial radius of 2.8 cm, the results are shown in Fig. 1. These results clearly indicated that it is advantageous to significantly reduce the initial beam radius. Corresponding calculations were done for various values of the beam radius. The results for the initial beam radius of 1.5 cm are presented in Fig. 2. As follows from this Figure, by using this method, the pasotron efficiency can be increased to more than 50%. These results also indicate that one can shorten the present helix, which is 40 cm long, by a factor of 2 without significant sacrificing the efficiency. As it will be shown below, these theoretical predictions were confirmed in the pasotron experiments carried out at UMD.

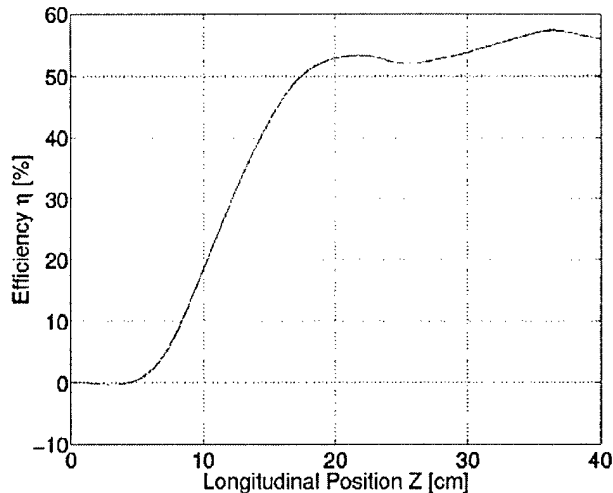

Figure 2: Electron efficiency of a beam with a small initial radius  $R_b=1.5\text{cm}$ . (see ref. 10 for other parameters)

(a) *Theory of mode interaction in backward-wave oscillators with strong end reflections.*

This work was motivated by HRL experimental data<sup>12</sup>. First, we should recall that, in order to shorten the interaction space, HRL's researchers suggested to use slow-wave structures (SWS's) with strong end reflections, because such reflections increase the RF field amplitude in the interaction region. Second, recall that it was shown that in the pasotron utilizing a helix SWS with strong reflections the voltage variations may cause a sudden frequency hopping. In order to explain this experimental result, the theory of BWO's with strong end reflections was developed. As is known, strong end reflections transform any SWS into a kind of resonator, in which a set of standing waves with different number of axial variations exists. This makes it possible to consider non-stationary processes in the device with such a SWS as the result of electron beam interaction with several axial modes. The developed theory, first, allowed us to determine the regions of stable operation in various axial modes, and second, it predicted the existence of various hysteresis effects associated either with hard self-excitation or with axial mode interaction.

(b) *Temporal evolution of electron beam transport*<sup>9</sup>.

As mentioned in the introduction, the transport of an intense electron beam through an interaction region in pasotrons is based on the focusing effect of a beam generated plasma channel (Bennett pinch). This focusing is an inherently time dependent process because initially there is no plasma in the gas-filled interaction region. So, during the initial stage of operation, the beam diverges due to its electric self-field and the plasma

appears in the process of beam impact ionization of gas molecules. Then, this plasma starts neutralization of the beam space charge field, which leads to the beam convergence. The change in the beam envelope, correspondingly, affects the process of further ionization etc. For the case of an axially homogeneous gas density this self-consistent non-stationary process was analyzed in Ref. 3. However, in recent experimental studies of an L-band pasotron at UMD, it was found that optimum operating conditions for microwave generation correspond to a gas density profile, which is strongly inhomogeneous in the axial direction. This fact motivated our study, which was aimed at the analysis of the effect of this strong inhomogeneity on the plasma formation and beam focusing.

The theory was developed, which describes non-stationary processes of plasma formation and beam transport in an initially inhomogeneous gas. It was taken into account that the beam space charge field creates a potential well for ions in both the transverse and axial directions. Typically, the period of transverse ion oscillations is much smaller (less than 1  $\mu$ sec) than the period of ion axial oscillations in the potential well and the characteristic ionization time. This fact was taken into account and two limiting cases were considered: one, when the period of ion axial oscillations,  $t_{ax}$ , is much smaller than the ionization time,  $t_{ion}$ , ("slow" ionization), and an opposite limiting case of "fast" ionization, when  $t_{ion} \ll t_{ax}$ . The results obtained are illustrated by Fig. 3 and 4, which show the temporal evolution of the beam radius in the cases of initially axially homogeneous and strongly inhomogeneous gas density profiles, respectively. Here solid and dashed lines correspond to, respectively, "fast" and "slow" ionization processes (the cases a, b, c and d in each figure correspond to different cross-sections of the device). These results show that in the case of the homogeneous gas profile the ion axial motion does not play any role; both models yield practically the same result. On the contrary, in the case of initially strong inhomogeneity (Fig.4) the ions' runaway from a high-density region provides slower pinching of the beam. However, at larger times the accumulation of movable ions in areas with initially low density of neutrals causes faster pinching. In Fig.4 this is the region where dashed curves correspond to smaller beam radii than solid curves.

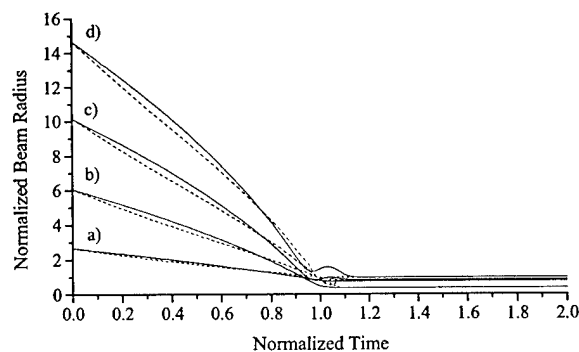
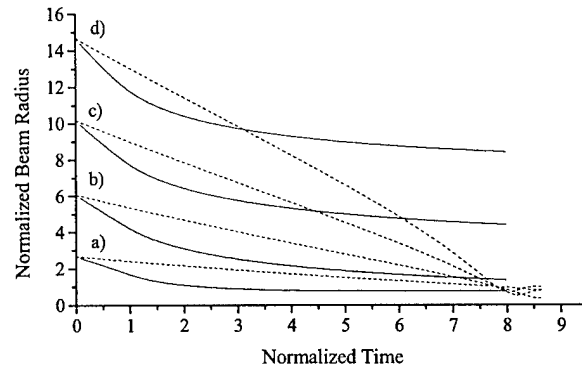

Figure 3: Beam pinching in the cases of fast (solid lines) and slow (dashed lines) ionizations in a gas with initially homogeneous axial profile of the density. Cases (a), (b), (c) and (d) correspond to different cross-sections.



*Figure 4: the same process as in Fig. 3, in a gas with strongly inhomogeneous axial profile of the density.*

## 2.2 Summary of recent experimental results

A "baseline" helix pasotron microwave source is shown schematically in Fig. 5.



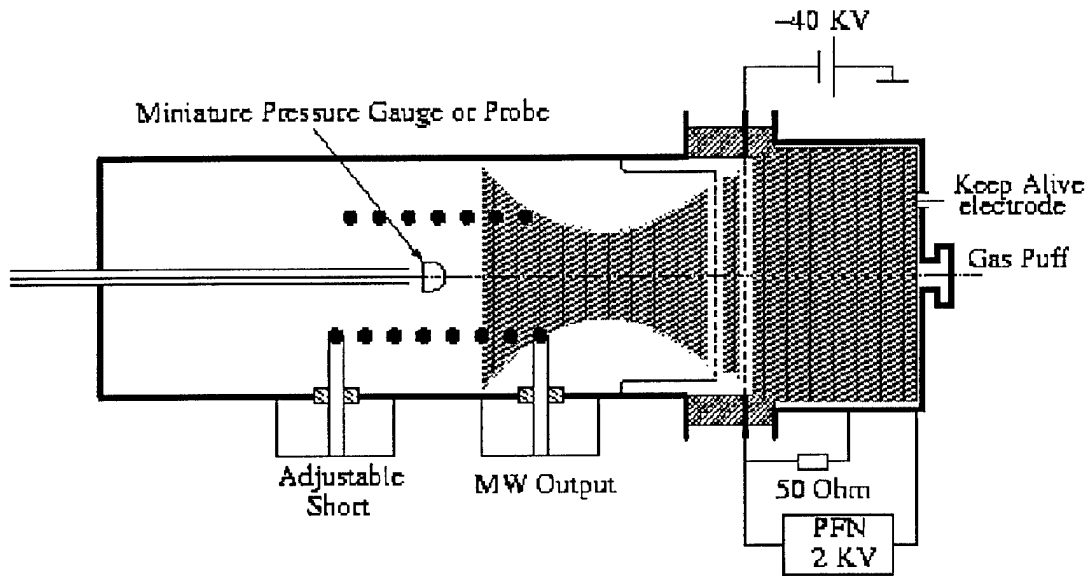

Figure 5: A schematic diagram of a "baseline" pasotron. The tube is equipped with an *in situ* probe to measure beam current density, plasma density or a miniaturized, fast response pressure gauge (helix radius=2.5cm, helix period=2.28cm, helix length=40cm)

The "baseline" tube is initially pumped to a base pressure of  $\sim 10^{-6}$  Torr. An electrically activated puff valve is used to fill the pasotron with neutral gas (helium) with a suitable axial distribution for proper plasma gun and helix region operation. The pasotron generates about 500 kW of microwave power at frequency  $\sim 1.2$  GHz with efficiency 15% when driven by a 40 kV, 80 A electron beam extracted from the plasma cathode. The pasotron regimes of operation were extensively diagnosed<sup>13</sup> with an array of *in-situ* sensors, including microwave measurements as well as axially moveable probes (for beam and plasma axial distribution measurements) and a moveable, miniature pulsed vacuum gauge for measuring the temporal evolution of the puff-generated pressure distribution.

The temporal evolution of gas density at four points (plasma gun, beam focusing region, helix begin and helix end) in the pasotron after puff valve activation is shown in Fig. 6. In addition, the effect of gas filling on pasotron operation was studied using a combination of puff and continuous gas filling. It was found that a helium pressure in the range of  $8 \cdot 10^{-4}$  to  $10^{-2}$  Torr is required for optimal plasma cathode operation. In contrast, a helium pressure  $< 5 \cdot 10^{-5}$  Torr must be maintained in the RF interaction region. At higher pressure, microwave breakdown is initiated, resulting in shortening of the microwave pulse. A delay time of 600-900  $\mu$ sec between puff valve activation and plasma gun activation simultaneously satisfy the pressure conditions described above.

The pressure profile effect on microwave production is illustrated in Fig. 7, where the microwave pulse amplitude and its duration, as function of delay time, is presented. One can see that for delays longer than 1 msec the microwave pulse duration decrease

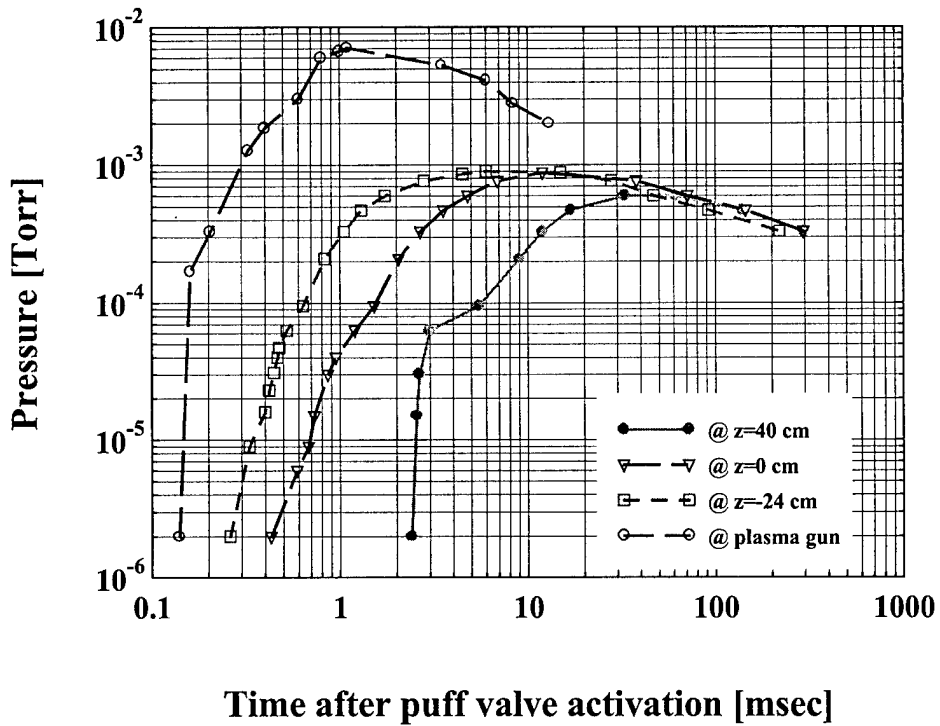

Figure 6: The temporal evolution of gas density at four points in the pasotron after puff valve activation (plasma gun, beam focusing region, helix begin and helix end)

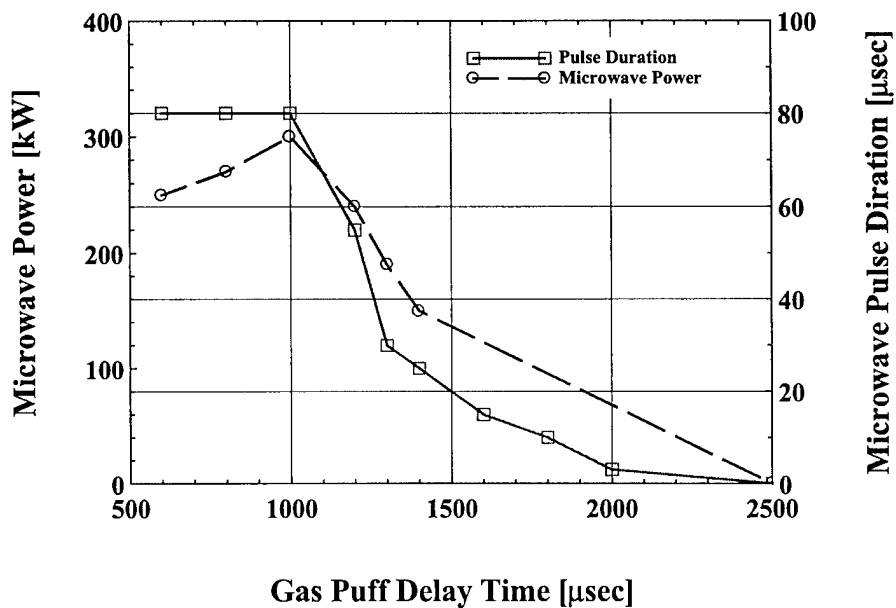

Figure 7: The microwave pulse amplitude and its duration in the pasotron, as function of delay time between puff valve and plasma cathode activation (note deterioration > 1msec)

with increasing delay. Furthermore, for delay larger than 1.4 msec the spectrum of the microwave radiation drastically deteriorates. At the instant that microwave production in the pasotron is shorted, a three order of magnitude increase in plasma density inside the helix interaction region is observed (to  $>10^{11} \text{ cm}^{-3}$ ). Under these conditions, beam transport through the interaction region is also drastically increased (by a factor of 10). The latter is illustrated by Fig. 8, where beam transport during microwave production and after microwave shortening is presented as the function of delay time.

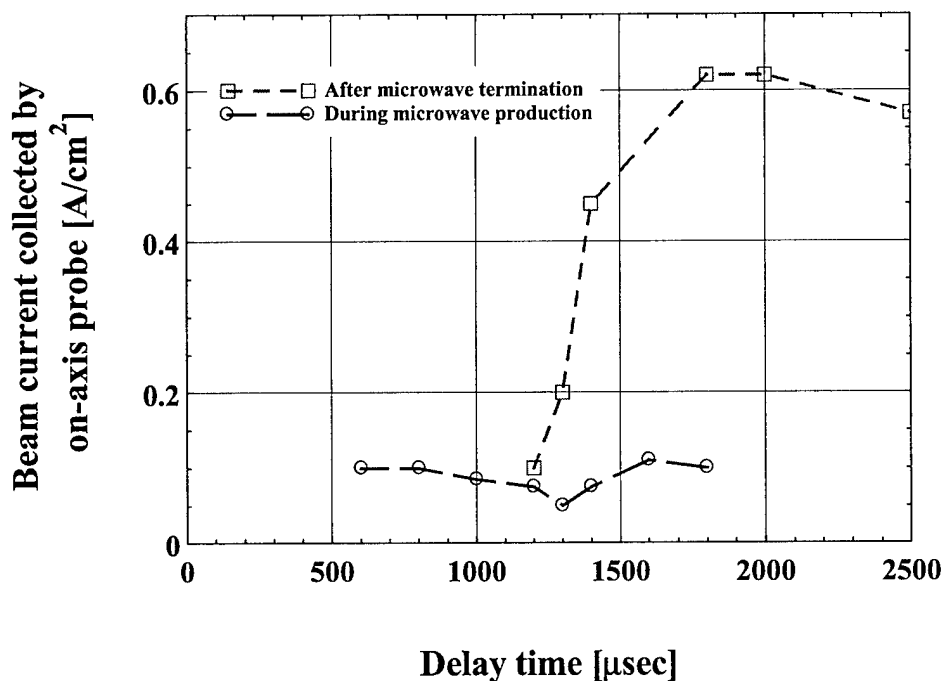

Figure 8: Pulse shortening in the pasotron due to excessive background gas pressure. It leads to a drastic increased (by a factor of 10) in beam transmission through the helix interaction region.

The strong inverse correlation between microwave production and beam transport support the assumption that strong RF fields induced by beam in the helix interaction region scatter the beam by overcoming the focusing self field in this region.

For improved understanding of RF field effects on beam-plasma formation, the beam-plasma axial distribution measurements were performed for a helix pasotron (microwave production regime) and a pasotron with a shorted helix (no microwave generation). In the latter case the helix was substituted by a smooth waveguide of similar dimensions.

The most direct evidence of strong RF field effect on beam transport is presented in Fig.9. In this figure, the measured axial distribution of the on-axis beam current density is plotted with and without RF. The on-axis beam current density decreases very quickly along the helix in the presence of RF, while in the absence of RF this dependence is much weaker. Experiments with partially shorted helix demonstrated that halving the helix length had only minimal effect on the microwave production capabilities of the pasotron. This is in good agreement with the data presented in Fig. 9.

In addition, it was found that the optimum guiding magnetic field for microwave production is  $\sim 90$  gauss. About 10% increase in output microwave power and a substantial increase in beam transport were measured under these conditions. A strong magnetic field ( $>100$  gauss) do not play a beneficial role in this plasma-assisted helix tube, since it is likely to suppress radial motion. Indeed, the addition of a strong guiding magnetic field caused an increase in beam transmission through the helix, but at the same time adversely effected the RF interaction.

Plasma density measurements show that in the operational regime (low gas pressure in helix), the plasma density is strongly effected by RF field, decreasing from  $2\text{-}5\cdot 10^9 \text{ cm}^{-3}$  (absence of RF fields) down to  $10^8 \text{ cm}^{-3}$  (with RF fields). The RF fields scatter the plasma from the interaction region. Few observations can be made based on the data presented so far:

- (a) Only about half of the total helix length (40-cm) actively participates in the "baseline" pasotron interaction.
- (b) RF dominates the beam dynamics in the interaction region.
- (c) RF strongly suppresses plasma accumulation in the helix interaction region.
- (d) Since the axial beam current decreases quickly with axial distance, radial motion is important.

These observations are substantiated by theoretical results described in section 2.1. Furthermore, it was found that substantial part of the beam current is not injected into the helix. Therefore, the reduced efficiency of the "baseline" pasotron is due to those electrons which "are not available" to the interaction. In other words, the conversion efficiency of those electrons entering the interaction region (electronic efficiency) should be much higher than the total device efficiency (which is based on the total cathode current). Since the cathode cross section ( $50\text{-cm}^2$ ) is much larger than the helix cross section ( $12.5\text{-cm}^2$ ), the beam-focusing region is critically important for high efficiency operation.

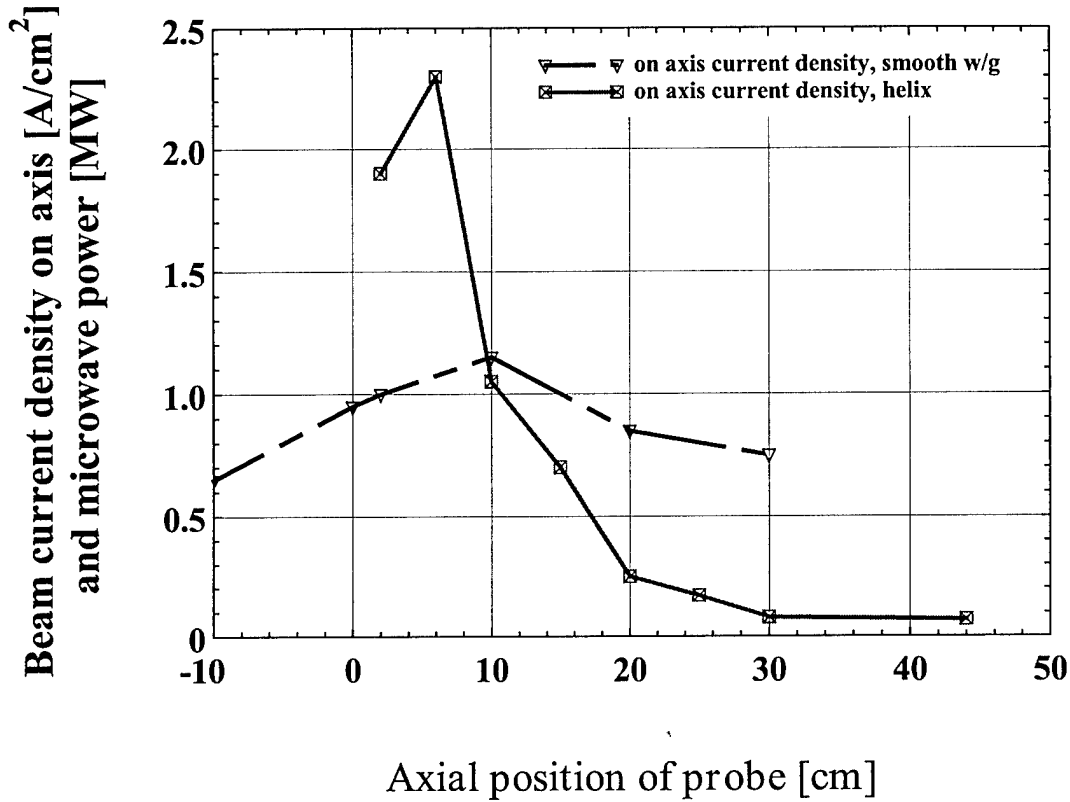
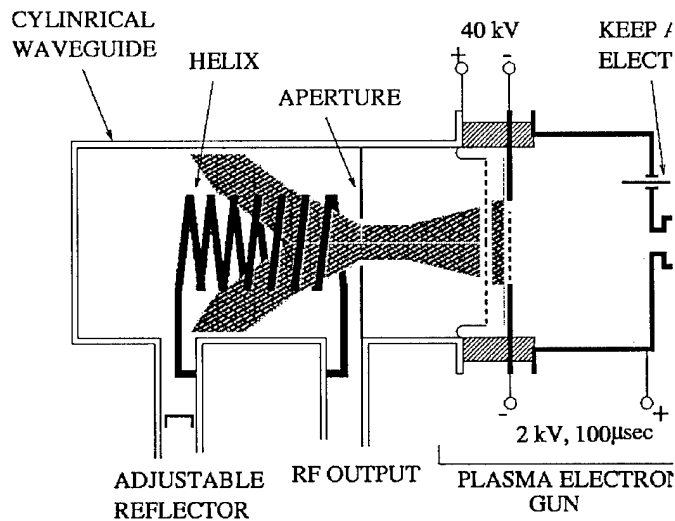

Figure 9: The measured axial distribution of on-axis beam current density inside the helix, with and without RF. In this latter case the helix is replaced by a smooth waveguide of similar dimensions. The on-axis beam current density decreases very quickly along the helix in the presence of RF, while in the absence of RF this dependence is much weaker.

In order to test this important issue, the “baseline” pasotron was initially fitted with a variable aperture between the helix and the plasma gun. The aperture serves two important purposes. First, it prevents intense electromagnetic fields, excited in the helix region, from “leaking” into the beam formation region, and strongly influencing the beam self-pinching process going on there. Second, it allows changing the cross section of the electron beam injected into the helix. By using an in-situ collector behind the aperture, the fraction of the cathode current actually injected into the helix was measured. The presence of the aperture allowed us to increase the total efficiency from 17% to 24% and to determine that the pasotron electronic (interaction) efficiency is ~40%.

The next step taken was to try to further increase the total pasotron efficiency, not just the electronic efficiency, by eliminating those parasitic, non-contributing electrons. This was achieved by modifying the gun geometry by changing and optimizing the transverse cross section of the electron beam. A schematic diagram of a high-efficiency

pasotron equipped with a modified electron gun is shown in Fig. 10. The innovation of using a tailored-profile electron beam indeed yielded an outstanding increase in both the efficiency and microwave power. Summary of these results is presented in table 1.



*Figure 10: A schematic diagram of a high efficiency pasotron equipped with a modified electron gun.*

From the table one can see that the total efficiency of the pasotron was improved from 17% to 32%<sup>14</sup>, and the interaction efficiency is ~40% (operating conditions described in section 2). Moreover, our recent theoretical results indicate that the pasotron efficiency, after optimization of beam optics, may be as high as 60-70%. This is going to be one of the main goals of the proposed program, to be described in section 3 and 4 below.

Table 1: Summary of pasotron efficiency studies

TYPE OF DEVICE	VOLTAGE [kV]	CURRENT [A]	ELECTRONIC EFFICIENCY [%]	TOTAL EFFICIENCY [%]
"Baseline" pasotron	40	80		17
Pasotron equipped with helix-entrance aperture	40	82	38	24
Pasotron equipped with modified gun	40	50	38	32
Future optimized Pasotron				$\geq 50\%$

### 3. Open issues

In order to benefit from recent impressive experimental and theoretical advances, few open issues should be addressed:

#### *Beam optics.*

So far our studies indicated that improved beam quality (reduced spread in transverse beam velocity) is needed in order to further increase the pasotron efficiency to values predicted theoretically (60-70%). This requires control of beam cross section and its transverse profile, and can be addressed by redesigning the plasma cathode gun.

#### *Beam focusing and transport.*

So far studies so far indicated that the physics of beam impact ionization, focussing and transport in the region between the plasma cathode and the RF interaction region is very important for plasma assisted microwave sources. This issue will be addressed by using our in-situ diagnostics in concert with numerical plasma simulations. The simulations will be performed with the most suitable plasma simulation code available-XOOPIC.

#### *RF interaction circuit and beam collection.*

Our theoretical and experimental studies clearly showed that the helix length could be substantially shortened. Shortening its length will effect the circuit quality factor Q, as well as end reflections, which should all be optimized. Also, the distance between the helix and the cathode should be optimized.

In addition, alternative beam collection approaches should be considered. For example, a modified helix may serve as an effective collector, which will substantially reduce tube diameter. Note that a magnetron is a high efficiency microwave generator where part of the beam is collected on the RF circuit.

*Noise characteristics.*

The issue of the noise and spectral content in pasotron was not addressed so far. To address this issue we propose to investigate non-stationary processes associated with beam pinching, plasma motion and RF generation, with the goal of understanding noise characteristics in plasma assisted tubes.



## References:

- <sup>1</sup> G. S. Nusinovich and Yu. P. Bliokh, "Mode interaction in backward-wave oscillators with strong end reflections", *Physics of Plasmas*, v.7, pp.1294-1301, April 2000.
- <sup>2</sup> G. S. Nusinovich and Yu. P. Bliokh, "Cherenkov radiation of electromagnetic waves by electron beams in the absence of external magnetic field", *Phys. Rev. E*, v.62, pp.2657-2666, August 2000.
- <sup>3</sup> T. M. Abu-elfadl, G. S. Nusinovich, A. G. Shkvarunets, Y. Carmel, T. M. Antonsen, Jr., and D. M. Goebel, "Traveling-wave tubes and backward-wave oscillators with weak external magnetic field", *Phys. Rev. E*, v.63, pp. , June 2001.
- <sup>4</sup> Yu. P. Bliokh and G. S. Nusinovich, "Temporal Evolution of Electron Beam Transport in Pasotrons", Submitted to *IEEE-PS*.
- <sup>5</sup> T. M. Abuelfadl, G. S. Nusinovich, A. G. Shkvarunets, Y. Carmel, T. M. Antonsen, Jr., and V. L. Granatstein, "Theory of Helix Pasotron Backward Wave Oscillator", (to be submitted to *Physics of Plasmas*).
- <sup>6</sup> G. S. Nusinovich and Yu. P. Bliokh, "Physics of Pasotrons", Invited talk at the 27<sup>th</sup> International Conference On Plasma Science, June 4-7, 2000, New Orleans, Louisiana, USA.
- <sup>7</sup> G. S. Nusinovich, Yu. P. Bliokh and T. M. Abuelfadl, "Cherenkov radiation in vacuum and plasma-filled microwave sources in the absence of guiding magnetic fields", Invited talk at the 25<sup>th</sup> International Conference on Infrared and Millimeter Waves, Beijing, P.R.China, Sept. 12-15, 2000.
- <sup>8</sup> T. M. Abuelfadl, G. Nusinovich, and Y. Carmel, "Theory of Traveling-wave Tubes with Weak External Magnetic Field", *APS-DPP*, Oct.23-27, 2000, Quebec, Canada; *Bull. APS*, Oct.2000, v.47, No.7, p.27.
- <sup>9</sup> T. M. Abuelfadl, G. S. Nusinovich, T. M. Antonsen, Jr., "Traveling-Wave Tubes and Backward-Wave Oscillators with Weak External Magnetic Field", International Conference on Pulsed Power and Plasma Science, Las Vegas, June 17-22, 2001.
- <sup>10</sup> D. M. Goebel, R. W. Schumacher, and R. L. Eisenhart, "Performance and Pulse Shortening Effects in a 200-kV PASOTRON HPM Source", *IEEE-PS*, v.26, pp.354-365, June 1998.
- <sup>11</sup> D. Chernin, T. M. Antonsen, Jr., and B. Levush, "Exact treatment of the dispersion and beam interaction impedance of a thin tape helix surrounded by a radially stratified dielectric", *IEEE-ED*, v.46, pp.1472-1483 (1999).
- <sup>12</sup> D.M. Goebel, E.A.Adler, E.S.Ponti, J.Feicht, R.Eisenhart, R.W.Lemke, "Efficiency Enhancement in High Power Microwave Oscillators", *IEEE Trans. Plasma Sci.*, 27, 800-808 (1999).
- <sup>13</sup> A. Shkvarunets, Y. Carmel, T. Antonsen, Jr., J. Rodgers, T. Abu-Elfadl, V. Granatstein, and D. Goebel, "Experimental Investigation of the Physics Processes in the Pasotron", International Conference on Pulsed Power and Plasma Science, Las Vegas, June 17-22, 2001.
- <sup>14</sup> "Realization of Highly Efficient, Plasma-Assisted Microwave source", manuscript for *Phys. Rev. Letter* in preparation.