

LOAN DOCUMENT

PHOTOGRAPH THIS SHEET

①

DTIC ACCESSION NUMBER

LEVEL

INVENTORY

AFAL-ML-TY-TR-2001-0046

DOCUMENT IDENTIFICATION

30 Jul 2001

DISTRIBUTION STATEMENT A
Approved for Public Release
Distribution Unlimited

DISTRIBUTION STATEMENT

DATE ACCESSIONED

DATE ACCESSIONED

DATE RETURNED

DATE RETURNED

| | |
|--------------------|-----------------------------|
| ACCESSION FOR | |
| NTIS | GRAM |
| DTIC | TRAC |
| UNANNOUNCED | |
| JUSTIFICATION | |
| BY | |
| DISTRIBUTION/ | |
| AVAILABILITY CODES | |
| DISTRIBUTION | AVAILABILITY AND/OR SPECIAL |
| A-1 | |

DISTRIBUTION STAMP

DATE RECEIVED IN DTIC

DATE RECEIVED IN DTIC

PHOTOGRAPH THIS SHEET AND RETURN TO DTIC-FDAC

H
A
N
D
L
E

W
I
T
H

C
A
R
E

20020627 198

AFRL-ML-TY-TR-2001-0046

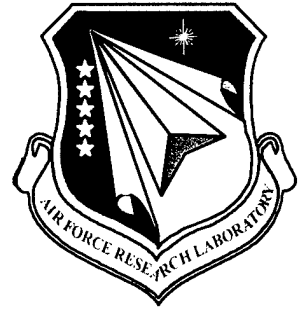

Plasma Waste Processing Demonstration System

Louis J. Circeo, Robert A. Newsom, Robert C. Martin and Lamar C. Carney

Plasma Applications Research Facility
Georgia Tech Research Institute
Georgia Institute of Technology
625 Lambert St., N. W.
Atlanta, GA, 30318-7070

Approved for Public Release; Distribution Unlimited

**AIR FORCE RESEARCH LABORATORY
MATERIALS & MANUFACTURING DIRECTORATE
AIR EXPEDITIONARY FORCES TECHNOLOGIES DIVISION
139 BARNES DRIVE, STE 2
TYNDALL AFB FL 32403-5323**

AQ402-09-1991

NOTICES

USING GOVERNMENT DRAWINGS, SPECIFICATIONS, OR OTHER DATA INCLUDED IN THIS DOCUMENT FOR ANY PURPOSE OTHER THAN GOVERNMENT PROCUREMENT DOES NOT IN ANY WAY OBLIGATE THE US GOVERNMENT. THE FACT THAT THE GOVERNMENT FORMULATED OR SUPPLIED THE DRAWINGS, SPECIFICATIONS, OR OTHER DATA DOES NOT LICENSE THE HOLDER OR ANY OTHER PERSON OR CORPORATION; OR CONVEY ANY RIGHTS OR PERMISSION TO MANUFACTURE, USE, OR SELL ANY PATENTED INVENTION THAT MAY RELATE TO THEM.

THIS REPORT IS RELEASABLE TO THE NATIONAL TECHNICAL INFORMATION SERVICE
5285 PORT ROYAL RD.

SPRINGFIELD VA 22 161

TELEPHONE 703 487 4650; 703 4874639 (TDD for the hearing-impaired)

E-MAIL orders@ntis.fedworld.gov

WWW <http://www.ntis.gov/index.html>

AT NTIS, IT WILL BE AVAILABLE TO THE GENERAL PUBLIC, INCLUDING FOREIGN NATIONS.

THIS TECHNICAL REPORT HAS BEEN REVIEWED AND IS APPROVED FOR PUBLICATION.



REZA SALAVANI
Program Manager

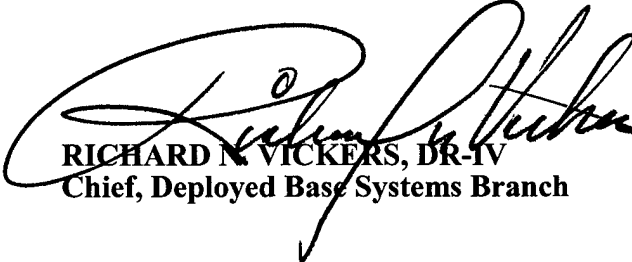

RICHARD N. VICKERS, DR-IV
Chief, Deployed Base Systems Branch



DONALD R. HUCKLE, JR., Colonel, USAF
Chief, Air Expeditionary Forces Technologies Division

Do not return copies of this report unless contractual obligations or notice on a specific document requires its return.

REPORT DOCUMENTATION PAGEForm Approved
OMB No. 0704-0188

Public reporting burden for this collection of information is estimated to average 1 hour per response, including the time for reviewing instructions, searching existing data sources, gathering and maintaining the data needed, and completing and reviewing the collection of information. Send comments regarding this burden estimate or any other aspect of this collection of information, including suggestions for reducing this burden, to Washington Headquarters Services, Directorate for Information Operations and Reports, 1215 Jefferson Davis Highway, Suite 1204, Arlington, VA 22202-4302, and to the Office of Management and Budget, Paperwork Reduction Project (0704-0188), Washington, DC 20503.

| | | | | |
|---|---|--|--|--|
| 1. AGENCY USE ONLY (Leave blank) | | 2. REPORT DATE 30 July 2001 | 3. REPORT TYPE AND DATES COVERED Final Report (01 Oct 00 – 30 July 01) | |
| 4. TITLE AND SUBTITLE Plasma Waste Processing Demonstration System | | | 5. FUNDING NUMBERS F08637-00-C-6013 | |
| 6. AUTHORS Circeo, Louis J., Newsom, Robert A., Martin, Robert C., Carney, C. Lamar | | | | |
| 7. PERFORMING ORGANIZATION NAME(S) AND ADDRESS(ES) Plasma Applications Research Facility Electro-Optics, Environment, and Materials Laboratory Georgia Tech Research Institute Atlanta, Georgia 30332 | | | 8. PERFORMING ORGANIZATION REPORT NUMBER GTRI A-6409 | |
| 9. SPONSORING/MONITORING AGENCY NAME(S) AND ADDRESS(ES) AFRL/MLQD 139 Barnes Drive, Ste 2 Tyndall AFB FL 32403-5323 | | | 10. SPONSORING/MONITORING AGENCY REPORT NUMBER AFRL-ML-TY-TR-2001-0046 | |
| 11. SUPPLEMENTARY NOTES AFRL/MLQD Project Manager: Reza Salavani, (850) 283-3715 | | | | |
| 12a. DISTRIBUTION/AVAILABILITY STATEMENT Approved for Public Release; Distribution Unlimited | | | 12b. DISTRIBUTION CODE A | |
| 13. ABSTRACT (Maximum 200 words) This research program was conducted to provide a small bench-scale Plasma Waste Processing System to the Air Force Research Laboratory (AFRL/MLQ). The program was successful in this effort to develop, and set up a batch-type 15kW Plasma Waste Processing Demonstration System at the Air Force Research Laboratory at Tyndall Air Force Base, Florida. The system allows the AFRL to demonstrate laboratory processing of small quantities of waste materials (up to 8 ounces) using an alternating current (AC) plasma torch system in a custom-fabricated reactor unit. Larger scale systems for the processing of wastes can be developed and demonstrated in future research programs by evaluating the performance and characteristics of using this bench-type system. | | | | |
| 14. SUBJECT TERMS Plasma Waste Processing, Alternating Current Plasma Torch, Reactor Unit | | | 15. NUMBER OF PAGES 68 | |
| | | | 16. PRICE CODE | |
| 17. SECURITY CLASSIFICATION OF REPORT UNCLASSIFIED | 18. SECURITY CLASSIFICATION OF THIS PAGE UNCLASSIFIED | 19. SECURITY CLASSIFICATION OF ABSTRACT UNCLASSIFIED | 20. LIMITATION OF ABSTRACT UL | |

TABLE OF CONTENTS

| | |
|---|-----|
| ACKNOWLEDGEMENTS | ii |
| TABLE OF CONTENTS | iii |
| EXECUTIVE SUMMARY..... | v |
| I. Technical Summary..... | 1 |
| II. Introduction | 1 |
| III. Program Tasks..... | 3 |
| A. Plasma Torch System | 3 |
| 1) System Requirements and Specifications | 3 |
| 2) System Design..... | 3 |
| B. Reactor Development..... | 5 |
| 1) Design..... | 5 |
| 2) Fabrication..... | 6 |
| 3) Assembly and Integration..... | 7 |
| C. Site Support | 7 |
| 1) Facility Requirements and System Delivery | 7 |
| 2) Setup and Checkout of System..... | 7 |
| IV. Shakedown Tests..... | 10 |
| V. Training | 11 |
| VI. Documents..... | 11 |
| a. Progress Reports..... | 11 |
| b. Operation/User and Training Document | 12 |
| VII. Summary | 12 |
| VIII. Appendices | 13 |
| Appendix A. Operation and User Manual Training Document | 14 |

Appendix B. SUI Operation Manual..... 29

Appendix C. Plasma Waste Processing System Demonstration Design Sketch..... 48

Appendix D. Crucible Information 50

Appendix E. View Port Details 53

Appendix F. Torch Connections 56

Appendix G. Reactor Seal Information..... 58

Appendix H. Thermocouple Information..... 61

Appendix I. Monthly Report Accomplishments 64

EXECUTIVE SUMMARY

This research program was conducted to provide a small bench-scale Plasma Waste Processing System to the Air Force Research Laboratory (AFRL/MLQ). The program was successful in this effort to develop, and set up a batch-type 15kW Plasma Waste Processing Demonstration System at the Air Force Research Laboratory at Tyndall Air Force Base, Florida. The system allows the AFRL to demonstrate laboratory processing of small quantities of waste materials (up to 8 ounces) using an alternating current (AC) plasma torch system in a custom-fabricated reactor unit. Larger scale systems for the processing of wastes can be developed and demonstrated in future research programs by evaluating the performance and characteristics of using this bench-type system.

Plasma Waste Processing Demonstration System

I. Technical Summary

The Georgia Tech Plasma Applications Research Facility (PARF) successfully accomplished the goals of this program. A small bench-scale laboratory plasma waste processing system was delivered to the Air Force Research Laboratory (AFRL/MLQ) at Tyndall Air Force Base in June 2001. The system consisted of a low power level (~15 KW) AC plasma torch to be operated in a custom-designed and fabricated reactor unit. The system was assembled and tested at the Georgia Tech Plasma Applications Research Facility and then relocated by its staff member to the Tyndall AFB AFRL Facility. A training session was conducted under this program for the Air Force personnel. Design and development programs for larger plasma processing systems are recommended for the future. Additional waste materials testing and evaluation can be accomplished at the Georgia Tech Plasma Applications Research Facility for higher power level plasma torches.

II. Introduction

Waste disposal during U.S. Air Force Base operations is the least developed infrastructure element. Current waste solutions are largely customized on site, requiring

significant support logistics and heavy equipment. A recent evaluation of bare base waste processing technologies concluded that plasma arc technology had the greatest potential for processing of sanitary wastes, medical wastes and most other hazardous wastes. Fuel gases created during this plasma pyrolysis process also offer a significant opportunity for power generation to operate the plasma torch and to meet other electrical requirements. The primary objective of this research program was to provide the Air Mobile Systems Branch, Air Base and Environmental Technology Division, Air Force Research Laboratory (AFRL/MLQ) with a laboratory-size plasma system capability to conduct small-scale waste processing investigations and to demonstrate plasma arc technology to appropriate U.S. Air Force agencies.

During the on site setup, a shakedown test was conducted to verify the system operation and to demonstrate the processing procedures. The shakedown test used ash material (197.7 grams) provided by the AFRL/MLQ. The system was successfully operated for 105 minutes to process the material. The material after processing was 91.6 grams. The weight reduction was over 50%.

The setup and shakedown included a training session for the operation and procedures to maintain the system. The manual in Appendix A has training details on the operation and procedures on the use of the reactor and the plasma heating system.

III. Program Tasks

A. Plasma Torch System

1) System Requirements and Specifications

The plasma waste processing demonstration system is developed with an AC type plasma heating system mounted in a specially fabricated crucible reactor unit. The criteria for the design were to be able to conduct plasma-processing experiments on small quantities (up to 8 ounces) of typical Air Force waste materials and analyze the process and the product. An additional purpose of the system is to demonstrate the process capabilities of plasma technology to potential Air Force users of this technology. The system source inputs include electrical AC power, compressed air, and water for cooling. The system outputs consist of draining ports for the cooling water; an exhaust port with a filter for the compressed gas and system exhaust, and a high-pressure relief port.

2) System Design

The system design incorporates a 15kW plasma-heating unit on loan to the AFRL/MLQ by Scientific Utilization, Inc. (SUI), and a custom-fabricated reactor. The plasma heating system consists of a power supply, a controller unit and the AC plasma torch. The power supply and the controller system furnish and condition the line AC voltage that operates the plasma torch. Photo 1 shows the custom-fabricated reactor and Photo 2 shows the power supply/controller.



Photo 1. Reactor Unit

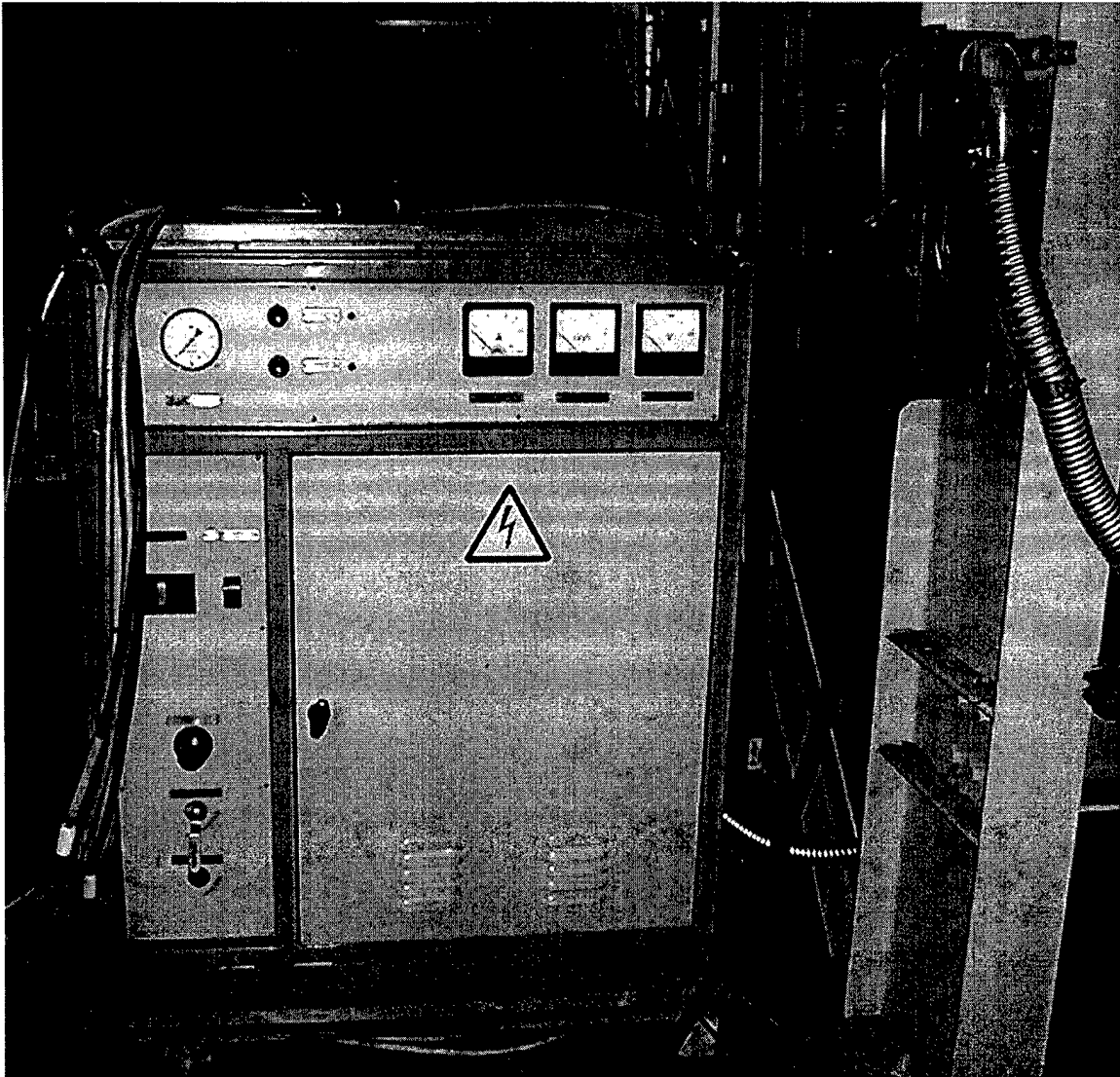

Photo 2. Power Supply/Controller

B. Reactor Development

1) Design

The design drawing for the Plasma Waste Processing Demonstration System is shown in Figure 1.

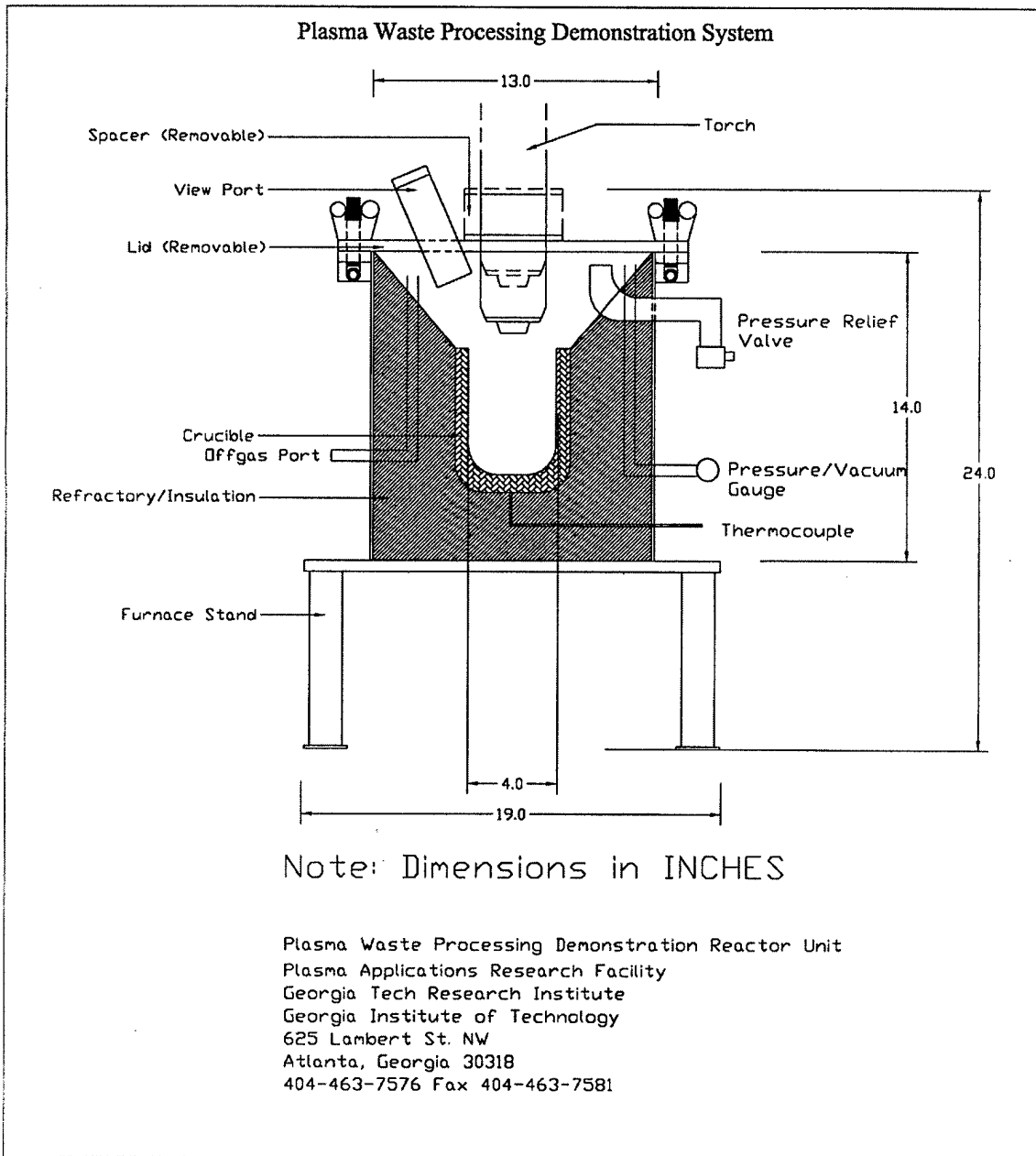

Figure 1. Plasma Waste Processing System

2) Fabrication

The Plasma Applications Research Facility staff fabricated the reactor. The main body of the reactor is constructed by modifying a stainless steel vessel. The vessel was welded to stainless steel legs. The lid of the vessel was constructed using a stainless steel plate

and attached to the reactor vessel with stainless steel hinges and closure bolts. The lid modifications included the torch and view port mounting. The reactor vessel modifications consisted of an offgas outlet, an overpressure valve, a thermocouple mount, installation of refractory and a graphite crucible. The reactor unit was mounted on a stand structure and attached to a platform with wheels for mobility.

3) Assembly and Integration

All the components for the system were assembled and integrated to the AC plasma arc torch heating system by the Georgia Tech Plasma Applications Research Facility staff.

C. Site Support

1) Facility Requirements and System Delivery

| | |
|----------------|---|
| Power Source | 480-Volt AC Single Phase, 200 Amps Fused Panel to Power Supply. |
| Water | 20 to 60 psi water supply (continuous flow 1- 4 gpm) at ambient temperature using standard hose fittings. |
| Compressed Air | 75 - 150 psi input to control panel. (0.4- 2.0 CFM) |
| Space Required | Control/Power Supply: 2.62 ft deep x 3.67 ft wide x 4.63 ft high Weight: ~1600 lbs. Furnace (floor space): ~3 ft x ~3 ft minimum |
| Ventilation | Test Area Exhaust Fan Desirable Furnace Exhaust Line |

2) Setup and Checkout of System

In June 2001, staff members from the Plasma Applications Research Facility conducted a site setup and checkout of the Plasma Waste Processing Demonstration System at the Tyndall AFB facility. The on site operation of the system was successful and the system processed a batch of ash material provided by the site staff. The following show photos and test data on the site operation:

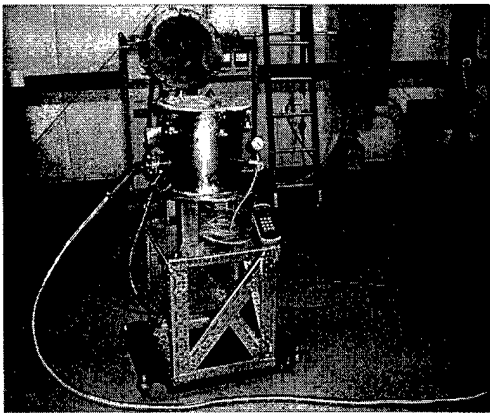

Photo 3. Plasma Reactor Unit

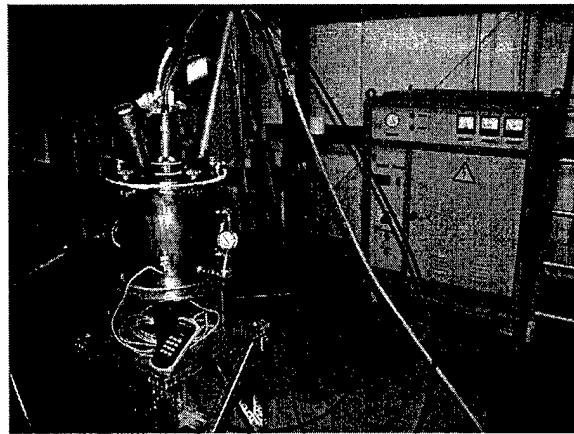
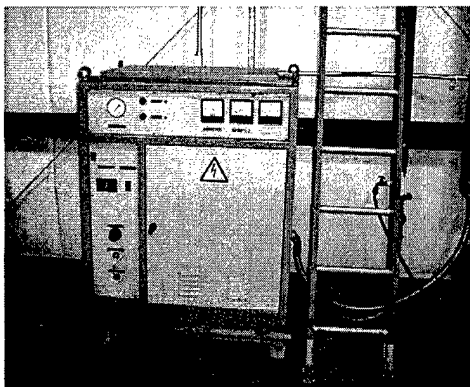

Photo 4. Reactor /Power Supply/Controller



•••••

Photo 5. Power Supply/Controller.

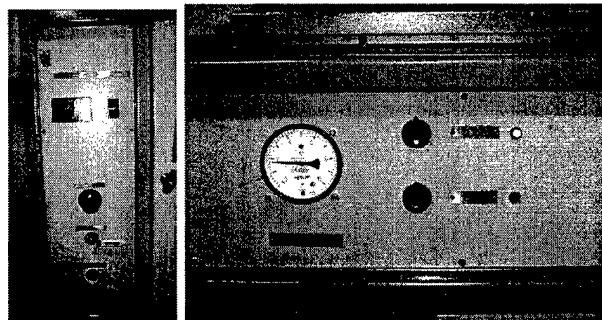

Photo 6. Controls

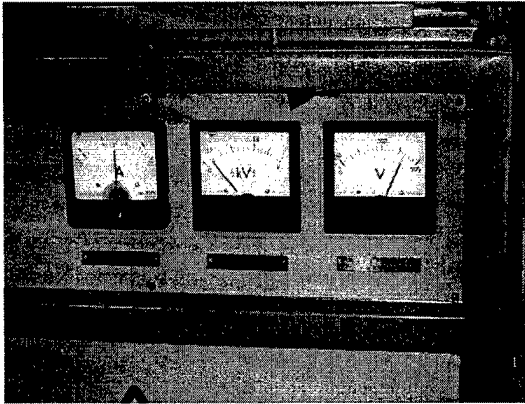

Photo 7. Monitoring Meters

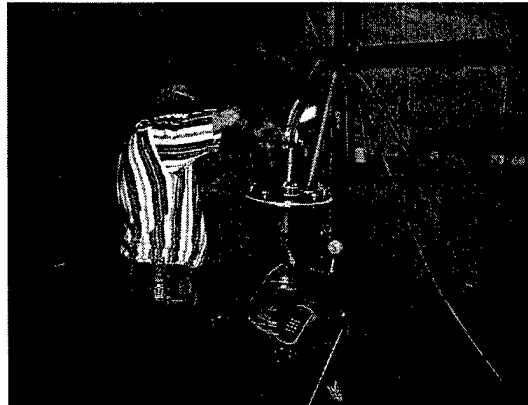

Photo 8. View Port Lens Installation

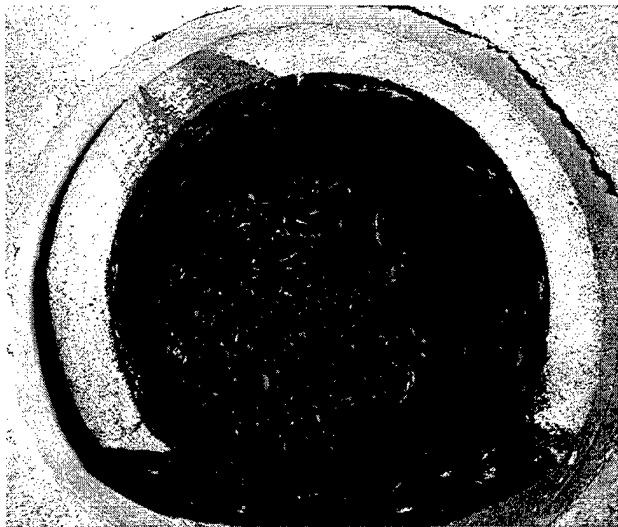

Photo 9. Crucible Reactor.

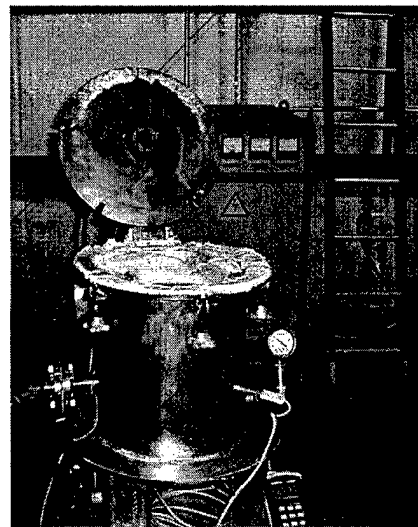

Photo 10. Lid Opened

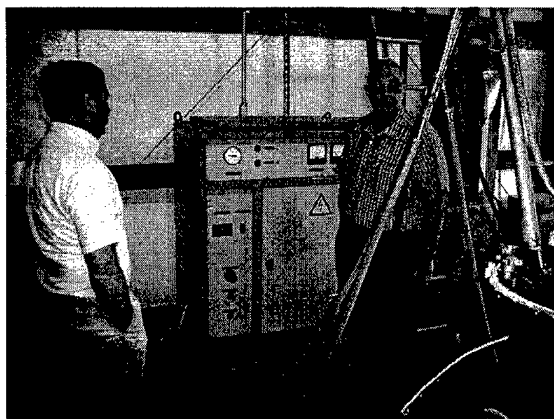

Photo 11. System Setup and Checkout

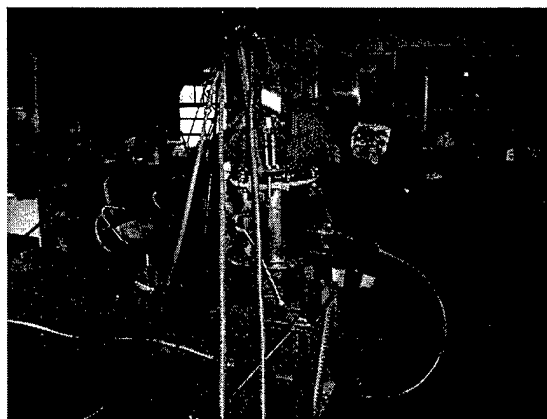

Photo 12. View Port Observation

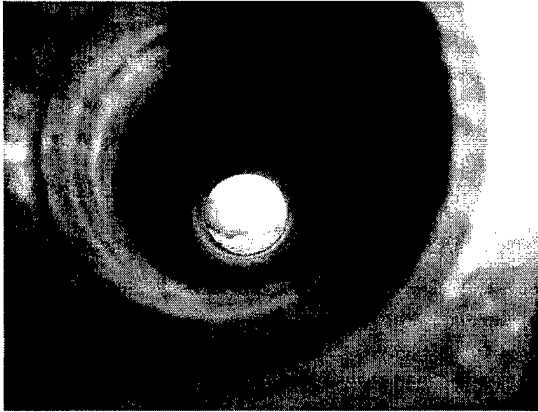

Photo 13. View Port Observation

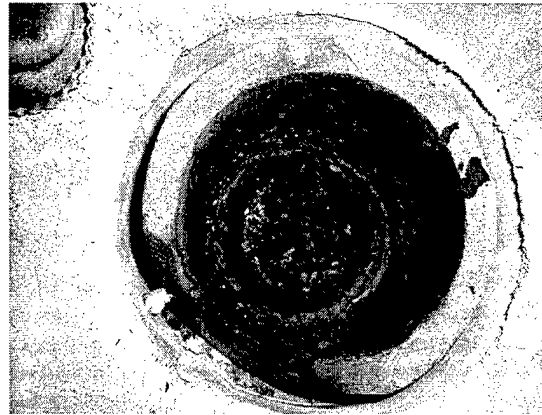
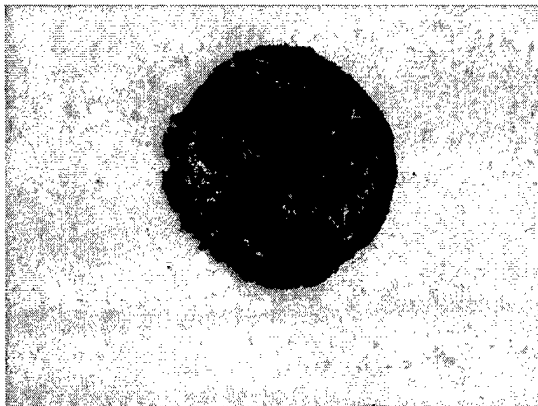

Photo 14. Crucible With Processed Ash



Processed Ash Material Removed From Crucible
Photo 14. Top view.

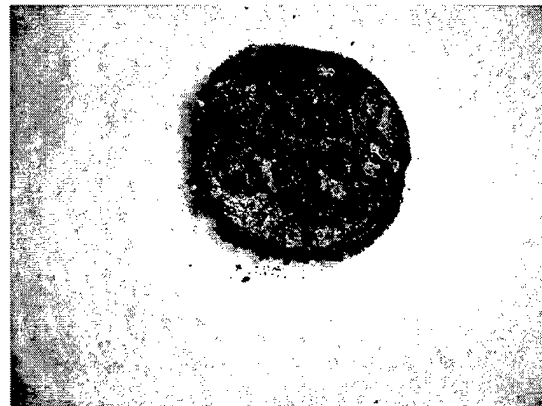

Photo 15. Bottom View

IV. Shakedown Tests

TEST DATA:

June 11 & 12, 2001

Tyndall AFB, FLA

Site Setup and Checkout of the Plasma Waste Processing Demonstration System.

Material Processed: CHTL (site material acronym designation) Ash

Weight: 197.7 g

Ash in crucible: 1905.4 g

Test Run:

Torch at Middle Position Height

Start System ON

30 minutes Temp = 250 °C

60 minutes Temp = 335 °C System OFF

65 minutes Opened Lid

Lowered Torch to Lowest Position

Restart Torch System ON

60 minutes Lowered air pressure 30 psi to 20 psi

65 minutes to 15 psi

105 minutes System OFF

Post Test

Processed Ash in Crucible: 1741.1 g

Processed Ash: 91.6 g

V. Training

During the setup and check out of the system, the Plasma Applications Research Facility staff conducted training and operational sessions for the Tyndall AFB AFRL/MLQ staff.

All information and technical training is contained in the Operation/User and Training

Document found in the Appendix A.

VI. Documents

a. Progress Reports

During this program monthly progress reports were submitted to the AF to monitor the program technical status. All the monthly progress reports were delivered on time.

b. Operation/User and Training Document

A training document for the Plasma Waste Processing Demonstration System has been incorporated in the operation/user document. This operation/user and training document was delivered with the system to Tyndall AFB, Florida in June 2001. A copy can be found in the Appendix A of this report.

VII. Summary

The delivery of the Plasma Waste Processing Demonstration System was successfully designed and custom-fabricated to meet the requirements for a small laboratory demonstration process evaluation plasma system. Within the financial limits of the program, the system was designed, a reactor unit was fabricated, the system delivered, setup and operated using the AC plasma arc torch on loan to AFRL/MLQ from SUI and made available for this program.

VIII. Appendices

Appendix A.
Operation and User Manual
Training Document

Plasma Waste Processing Demonstration System

Operation and User Manual

Training Document

GTRI A-6409

Contract No.

F08637-00-C-6013

Tyndall Air Force Base, Florida

June 8, 2001

TABLE OF CONTENTS

| | | |
|------|---|---|
| I. | Introduction..... | 1 |
| II. | Safety Information..... | 1 |
| | United States OSHA Lockout/Tagout Requirements..... | 1 |
| | Electrical Safety | 1 |
| | High Temperature Safety..... | 2 |
| | Processed Material Handling | 2 |
| | Optical Safety..... | 2 |
| III. | General Information | 2 |
| | a. System Requirements and Specifications | 2 |
| | b. System Design..... | 2 |
| IV. | Installation and Integration | 3 |
| | a. Space Requirements..... | 3 |
| | b. Positioning of System | 4 |
| | c. Electrical | 4 |
| | d. Water Supply | 4 |
| | e. Torch Gas Supply | 4 |
| | f. Reactor Outlets | 4 |
| | g. Temperature Measurement Unit..... | 5 |
| V. | Operating Procedures | 5 |
| | a. General..... | 5 |
| | b. Startup..... | 5 |

| | |
|---|----|
| c. Running..... | 6 |
| d. Shutdown..... | 6 |
| VI. Components | 7 |
| a. Plasma Heating System..... | 7 |
| 1) Plasma Power Supply and Control Console..... | 7 |
| 2) Plasma Torch..... | 7 |
| b. Reactor Unit | 7 |
| 1) Reactor Chamber..... | 7 |
| 2) Crucible | 8 |
| 3) View Port..... | 8 |
| 4) Connections | 8 |
| 5) Seals | 9 |
| 6) Thermocouple and Meter | 9 |
| 7) Miscellaneous Items..... | 10 |
| VII. Recommended Spare Parts List | 10 |
| VIII. Summary..... | 11 |

Plasma Waste Processing Demonstration System

Operation and User Manual

I. Introduction

Waste disposal during U.S. Air Force Bare Base operations is the least developed infrastructure element. Current waste solutions are largely customized on site, requiring significant support logistics and heavy equipment. A recent evaluation of bare base waste processing technologies concluded that plasma arc technology had the greatest potential for processing of sanitary wastes, medical wastes and most other hazardous wastes. Fuel gases created during this plasma pyrolysis process also offer a significant opportunity for power generation to operate the plasma torch and to meet other electrical requirements. The primary objective of this research program would be to provide the Air Mobile Systems Branch, Air Base and Environmental Technology Division, Air Force Research Laboratory (AFRL/MLQ) with a laboratory-size plasma system capability to conduct small-scale waste processing investigations and to demonstrate plasma arc technology to appropriate U.S. Air Force agencies.

II. Safety Information

United States OSHA Lockout/Tagout Requirements

To comply with the United States OSHA lockout/tagout standards (29 CFR part 1910) the facility needs to install lockable devices on all water supply lines, compressed air supply lines, and electrical supplies to the Plasma Waste Processing Demonstration System.

Electrical Safety

The Plasma Waste Processing Demonstration System is operated with high electrical power as its energy source. The power supply is a self-contained power regulator and control unit that supplies single phase high voltage and alternating current to the plasma torch. The power is delivered to the torch via three cables (voltage, return, ground).

Electrical safety standards are to be applied in handling and operating the equipment.

High Temperature Safety

This system function is to generate a very high thermal process for the remediation of materials. Safety precautions procedures required for this system during and after a process demonstration includes: the reactor surface area, the opening of the reactor lid, the removal of the crucible unit, the removal of the processed material.

Processed Material Handling

The processed material requires that caution be taken in handling due to thermal levels and to the material being in a vitrified (glass like) state.

Optical Safety

The plasma torch generates a thermal plasma field that radiates an optical frequency that can damage the eye if direct visual viewing is conducted without a protective shield or glasses.

III. General Information

a. System Requirements and Specifications

The plasma demonstration system is developed with an AC type plasma heating system mounted in a specially fabricated crucible reactor unit. The criteria for the design was to be able to conduct low volume plasma experiments on typical Air Force waste materials and analyze the process and the product. An additional purpose of the system is to demonstrate the process capabilities. The system source inputs include electrical AC power, compressed air, and water for cooling. The system outputs consist of draining ports for the cooling water; exhaust port with a filter for the compressed gas and system exhaust, and a high-pressure relief port.

b. System Design

The system design incorporates the SUI 15kW plasma-heating unit and a fabricated reactor. The plasma-heating system is a power supply and controller unit and the AC

plasma torch. The power supply using the controller system furnishes and conditions the line AC voltage that operates the plasma torch. The manual for the SUI system is located in the Appendix.

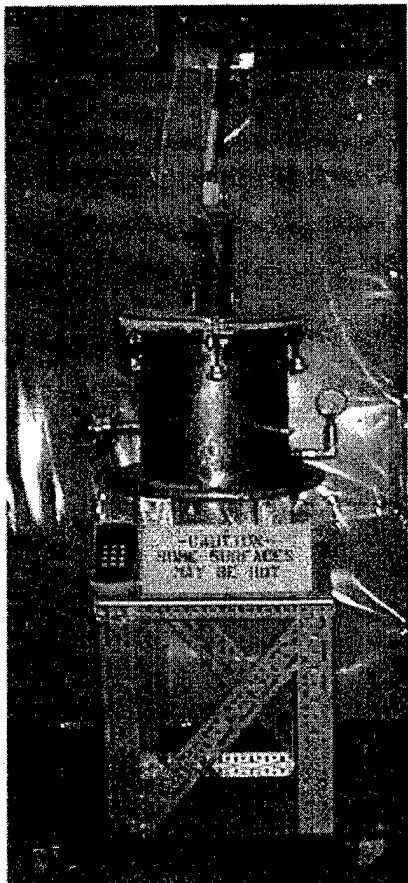

Photo 1. Reactor

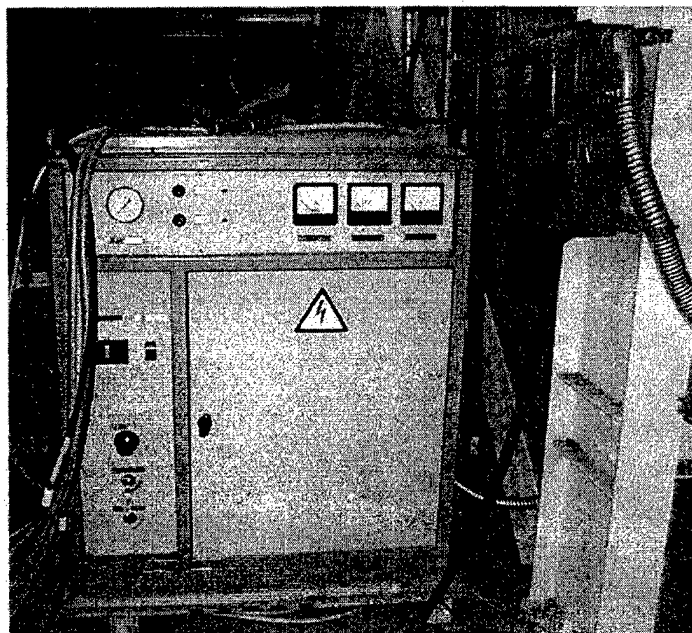

Photo 2. Power Supply/Controller

IV. Installation and Integration

a. Space Requirements

The Plasma Waste Processing Demonstration System will need a space allocation appropriate to safely operate and maintain both the power supply/controller and the reactor unit. The power supply/controller cabinet is physically 1120 mm (length) by 800 mm (width) by 1410 mm (height) with a weight of 710 kg. The reactor unit was fabricated under this contract as defined by the statement of work. As a demonstration system the function of the reactor is to illustrate the plasma technology capability for

processing of potential waste remedial material candidates. The reactor unit is mounted on a castor platform.

b. Positioning of System

The positioning of the Plasma Waste Processing Demonstration System is limited to 5 meters distance between the plasma torch (located on the top of the reactor unit) and the power supply/controller cabinet. The power supply/controller cabinet needs to be located so that adequate ventilation is available, and that access to the rear and front doors is appropriate. The reactor needs to be properly positioned to allow safety issues for the power and temperature to be adequately monitored for both personnel and facilities.

c. Electrical

The electrical installation for the Plasma Waste Processing Demonstration System requires the connection of 480 volt single phase with 150 Ampere service to be provided via an appropriately rated fused (or circuit breaker) switch panel. The cabling is from the power supply/controller to the fused switch panel. The plasma torch is cabled to the reactor via cabling provided by manufacturer. A proper grounding cable is provided and requires connection to the facility grounding system.

d. Water Supply

A water connection to the plasma torch for cooling is to be provided via the power supply/controller unit. The rate of 1 to 4 gallons per minute is to be provided to the power supply/controller unit.

e. Torch Gas Supply

The plasma torch is supplied gas for the plasma via the power supply/controller unit. A source of 75 to 150 psi at 0.4 to 2.0 cfm is to be provided to the power supply/controller unit.

f. Reactor Outlets

The reactor unit has outlet ports for offgas and over pressure release. The offgas port is to be maintained under a vacuum (.05 to 2.0 inches of water) to properly draw the gas

effluent for monitoring/treated. The overpressure release valve is rated at 50 psi. This port is to be vented to a safety release location.

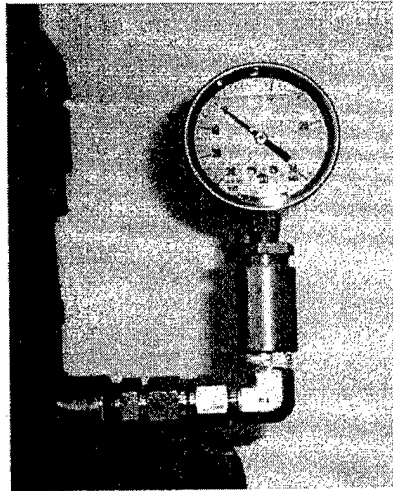

Photo 3. Pressure Gauge

g. Temperature Measurement Unit

The Plasma Waste Processing Demonstration System reactor unit is provided with a temperature measurement monitor. A thermocouple is the sensing element and is installed in the side of the reactor and the base of the processing crucible. The thermocouple and cable is connected to the monitoring meter, which data can be monitored and stored on a computer via vendor-supplied software.

V. Operating Procedures

a. General

The Plasma Waste Processing Demonstration System is a single-phase alternating current plasma torch generation system. The plasma torch produces very high temperature gas streams. The plasma torch is mounted in a custom designed and fabricated reactor with a crucible for processing selected waste materials.

b. Startup

The startup procedure is:

- Check and verify that water is ON and properly connected without leaks.
 - Check the gas is ON and operating within operational parameters.
 - Check all electrical and grounding connections.
 - Verify that the area ventilation system is operating and adequate.
 - Load the reactor with the test material in the coated crucible.
 - Verify that all outlet ports are clear and open.
 - Install ceramic blanket insulator on top reactor flange and close lid with slide screw clamps.
 - Verify the desired position of the plasma torch lid spacer and proper sealing insulation rings are installed.
 - Turn on the facility electrical source (close switch).
 - Open water and gas supply valves.
 - Close circuit breakers on the power supply/controller.
 - Press the button "SWITCH ON" to energize the system contactor to start the plasma torch.
- c. **Running**
- Monitor the power supply/controller for power indication.
 - The plasma arc is regulated by variations in the gas supply rate.
 - Monitor the process via the temperature measurement and optically by means of the view port.
- d. **Shutdown**
- Press the button "SWITCH OFF" to de-energize the system contactor to stop the plasma torch.
 - CAUTION!! Do not open the reactor to remove the processed material until a proper cooled temperature is reached to safely remove the material.

- Turn off thermocouple data collection instrument after cool down measurements are completed or as appropriate.
- Turn OFF the gas source to the system.
- DO NOT TURN OFF THE COOLING WATER SUPPLY UNTIL THE REACTOR HAS COOLED DOWN OR THE TOP IS POSITIONED OUT OF THE THERMAL AREA OF THE PROCESSED MATERIAL.

VI. Components

a. Plasma Heating System

1) Plasma Power Supply and Control Console

The plasma power supply and control console for the Plasma Waste Processing Demonstration System is a Scientific Utilization, Inc (SUI) system on loan to AFRL/MLQ. All operational and technical data is furnished by SUI.

2) Plasma Torch

The plasma torch for the Plasma Waste Processing Demonstration System is a Scientific Utilization, Inc (SUI) system on loan to AFRL/MLQ. All operational and technical data that is furnished by SUI can be found in the Appendix.

b. Reactor Unit

The reactor is a custom designed and fabricated processing unit for the Plasma Waste Processing Demonstration System developed under this contract by the staff at the Georgia Tech Plasma Applications Research Facility. The design documents can be located in the Appendix. Some criteria parameters for the major components are described in the following sections:

1) Reactor Chamber

The reactor chamber is a stainless steel unit developed to process materials at high

thermal levels using a plasma torch. The chamber of the reactor is lined with a thermal isolation refractory material that surrounds a removable processing crucible. Diagram sketch of the reactor chamber is located in the Appendix.

2) Crucible

The vendor for the crucible is Budget Casting Supply. The crucible is a modified #6 Clay Graphite Crucible vendor #5060. The modification is a removal of the top edge section to allow the view port visual inspection during the process. The crucible is recommended to be coated with a graphite base material TARRCOAT to increase the life of the crucible and to assist as a releasing agent for the processed material. Information on the crucible and the coating material is located in the Appendix.

3) View Port

The view port is mounted on the lid of the reactor and contains quartz lenses that allow the visual viewing of the process. Information on the lenses is contained in the Appendix. Cleaning of the lenses during processing may be necessary due to process coating of the internal surfaces of the lens. This can be accomplished by turning off the torch and carefully using thermal gloves to remove and clean the lens. Using the thermal gloves the lens can be replaced.

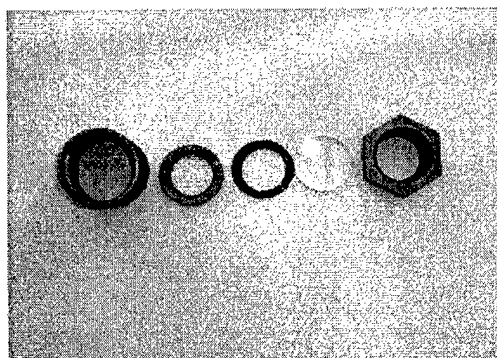
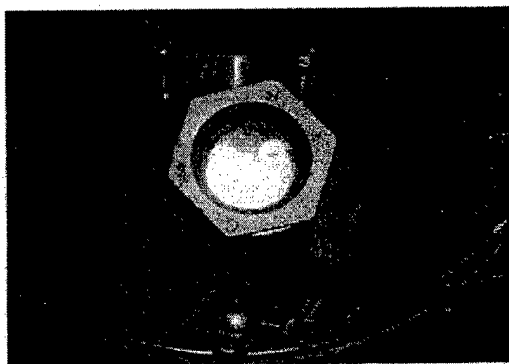

Photo 4. View Port and Assembly

4) Connections

The Plasma Waste Processing Demonstration System consists of the power

supply/controller connections from the facility sources, power supply/controller to the reactor connections, and thermocouple sensor and meter connections.

5) Seals

The reactor chamber includes seals for processing isolation. These seals are the plasma torch lid mounting gasket and the lid sealing ceramic blanket gasket. Information on the these materials is located in the Appendix.

6) Thermocouple and Meter

The thermocouple for the Plasma Waste Processing Demonstration System is a standard K type. Other types can be used if compatible with the meter. The thermocouple is custom assembled using off the shelf components. The vendor used for these components is Omega. The assembly for the system thermocouple uses dual holed ceramic insulating spaces, and a high thermal plug. The Omega measurement meter supplied with the Plasma Waste Processing Demonstration System thermocouple unit includes software for PC data collection.

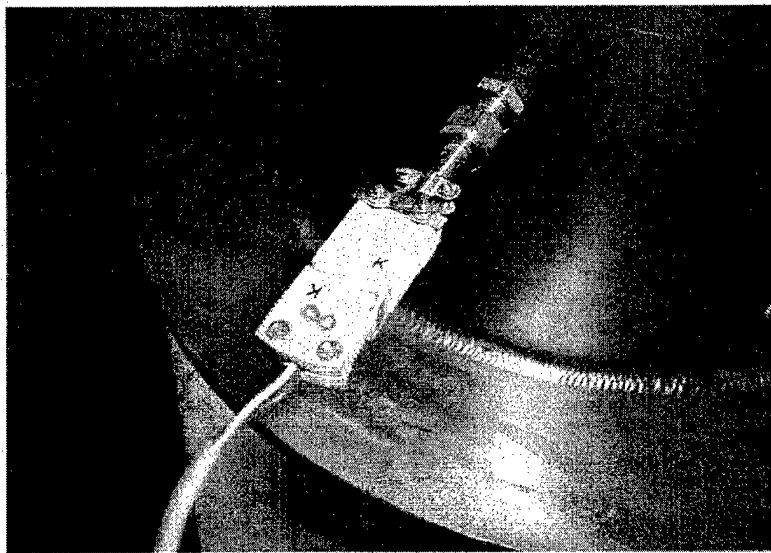

Photo 5. Thermocouple Connection

7) Miscellaneous Items

Miscellaneous items information that is used in the assembly of the Plasma Waste Processing Demonstration System can be found in the table of parts. These include pressure/vacuum gauge, lid screws and knobs, gasket material, pressure relief valve.

VII. Recommended Spare Parts List

| Item # | Vendor | Vendor # | Description | Qty |
|--------|---------------------|---------------------------|---|-----------|
| 1 | Omega | CHAL-032 | Thermocouple K type | 2 |
| 2 | Omega | DH-1-20-12 | Thermocouple Ceramic Sleeve | 12 |
| 3 | Omega | SHX-K-F/M | Connector | 2 |
| 4 | Omega | PCLM-SMP-RSC | Cable Clamp | 2 |
| 5 | Thermal Ceramics | Custom | Lid Casket Ceramic Seal | 10 |
| 6 | KLINGER | Custom C-4401 | Reactor/Torch Seal Gasket | 2 sets |
| 7 | SUI | Custom | Torch Electrodes | 10 |
| 8 | American Refractory | #5060 #6 Clay Graphite | Crucible | 2 |
| 9 | American Refractory | STARRCOAT G | Crucible Coating | 1 pint |
| 10 | McMaster-Carr | 8477K48 | Pyrex Lens 2 inch diameter, ¼ inch thick | 2 |

VIII. Summary

The Plasma Waste Processing Demonstration System was successfully developed for Tyndall AFB to allow demonstration and laboratory experiments on the types of materials that the Air Force need to environmentally process. The system was delivered and installed at Tyndall Air Force Base, Florida in June 2001.

Appendix B.
SUI Operation Manual

- 1 -

OPERATION MANUAL
ON A SINGLE-PHASE PLASMA GENERATOR OF POWER
SUPPLY SYSTEM

28G. 790. 001 TO and IE

CONTENTS

| | Page |
|--|------|
| 1. Introduction..... | 3 |
| 2. Purpose | 3 |
| 3. Design and operation of the device..... | 3 |
| 4. Arrangement and installation..... | 3 |
| 5. Marking..... | 4 |
| 6. Safety precautions..... | 4 |
| 7. Preparation to operation..... | 4 |
| 8. The order of operation..... | 5 |
| 9. Control and adjustment..... | 5 |
| 10. Technical maintenance..... | 5 |
| 11. Trouble-shooting..... | 6 |
| 12. Transportation and storage | 6 |
| Appendix 1. Fig. 1 | 7 |
| Fig. 2 | 8 |
| Fig. 3 | 9 |
| Table of diameters of orifice plates (mm) | 10 |
| Appendix 2. Diagrams | |
| Schematic circuit diagram | |
| Principal hydraulic scheme | |
| Principal gas scheme | |

1. INTRODUCTION

The following manual is intended for the study of the attending personnel who will operate the single-phase plasma generators of power supply system (further on - device) and contains the information, needed for its correct exploitation.

2. PURPOSE

2.1. The device is intended for producing high temperature gas streams.

2.2. The device can be used for solving of different practical and research problems in chemical, medical and biological fields of science and industry.

2.3. All technical specifications are given in the certificate 2BG. 790. 001 PS.

3. DESIGN AND OPERATION OF THE DEVICE

The device (Fig.1) consists of 2 plasma generators PO-6(1), PO-7(2), control cabinet with power supply source installed in it, control system and systems of water- and gas-supply.

Plasma generator PO-6 consists of the following main units: body 1, electrodes 2, tips 3, nozzle 4 (Fig. 2).

Plasma generator PO-7 consists of the following main units: body 1, electrodes 2, tips 3, tubes 4 (Fig. 3).

In the power supply cabinet there are different facilities of electric circuit, water- and gas-supply systems, control system. Connecting wires and hoses provide the possibility of placing the plasmatron at the distance of 5 metres.

The work of the plasmatron is based on the following: 6 kV voltage is applied to the central electrodes and it causes break-down in the air between the tip and the wall of the channel, and an electric arc strikes across the gap of the each channel. Due to the tangential gas stream the arcs move towards the edges of the channels and close among themselves. Thus only central electrodes are in use for the work. In case of the interruption of the arcs the process is repeated. Cooling of the plasma generators casing is accomplished by water.

4. ARRANGEMENT AND INSTALLATION

4.1. The device is placed in the separate room.
The terms of the exploitation :

- ambient temperature from +5 C to +40 C;
- relative humidity up to 80% at the t = +25 C;

- 4 -

- atmospheric pressure from 84000 Pa (630 mm Hg)
to 106700 Pa (800 mm Hg).

4.2. Open the boxes. Remove away the slushing lubrication from the metal parts of the device, using the wad moistened with the aircraft gasoline.

Provide the visual inspection of the plasma generators, cabinet, connecting wires and hoses.

4.3. Check up for the completeness in accordance with the delivery set given in the certificate.

4.4. Place plasmatron on the support. Install the cabinet. Attach the cabinet to the plasmatron with a help of the wires and hoses and in the conformity with the marking.

5. MARKING

Marking is put on the plates and fixed to the cabinets and plasma generators. Marking includes the trade mark of the plantproducer, unit's name, serial number, year of production.

6. SAFETY PRECAUTIONS

6.1. In the process of the device's mounting and exploitation general statements on safety measures, accepted at this plant, are in work.

6.2. It's prohibited to accomplish works in the cabinet and on plasma generators, while the unit is connected to the supply line.

6.3. It's prohibited to use the device without grounding and in the premises, not equipped with the ventilation system.

6.4. The attendants must use welder's helmets or goggles to protect their faces and eyes from plasma stream radiation.

6.5. It's allowed to operate the device only after proper training and passing the exams on the knowledge of operation manual and safety regulations.

7. PREPARATION TO OPERATION

7.1. Check up the water availability and its resistivity.

7.2. Check up the gas availability and corresponding pressure at the input.

7.3. Switch on the cooling system, make sure that there is no water leakage at the joints.

- 5 -

7.4. Check up the existance of the grounding.

7.5. The premises should be equipped with the system of forced ventilation.

8. CONTROL AND ADJUSTMENT

8.1. Open the water and gas supply valves.

8.2. Close the circuit - breaker.

8.3. Press the button "Switch on" to energize contactor and start the device.

8.4. The intensity of electric arc is regulated by the gas supply valve.

8.5. Press the button "Switch off" to de - energize the contactor and switch off the device.

9. THE ORDER OF OPERATION

9.1. The plasma generator power adjusment is smooth and accomplished by the change of the arc current .The arc current is adjusted by the replacement of the magnetic shunts .In this type of the high-voltage transformer there are two shunts providing 5A and 10A current for the plasma generator.

9.2. The average mass temperature of the gas stream from the plasmatron is regulated by the gas rate with a help of the valve.

10. TECHNICAL MAINTENANCE

10.1. Check up periodically the joints of cooling system for absence of water leakage.

10.2. Wipe the cylindric channels of the plasmatron in every 25 hours of work.

10.3. Electrodes tips shall be replaced in 100 hours of work.

- 6 -

11. TROUBLE-SHOOTING

11.1. List of possible troubles.

| Description of the trouble | Possible reason | Method of its removing |
|---------------------------------------|---|--|
| 1. Plasmatron is not started | a) absence of high voltage b) break-down of electrodes insulator c) change of disruptive distance | check up power transformer replace replace the tip |
| 2. Arc is not drawn from the channels | a) shortage of the gas stream b) carbon on the channels walls c) change of disruptive distance in one of the chanel | increase it clean them replace the tip |

12. TRANSPORTATION AND STORAGE

12.1. Packed device may be transported by any means of transportation.

12.2. The device shall be transported in vertical position in the fixed hard packing.

12.3. The storage in the open is prohibited.

7

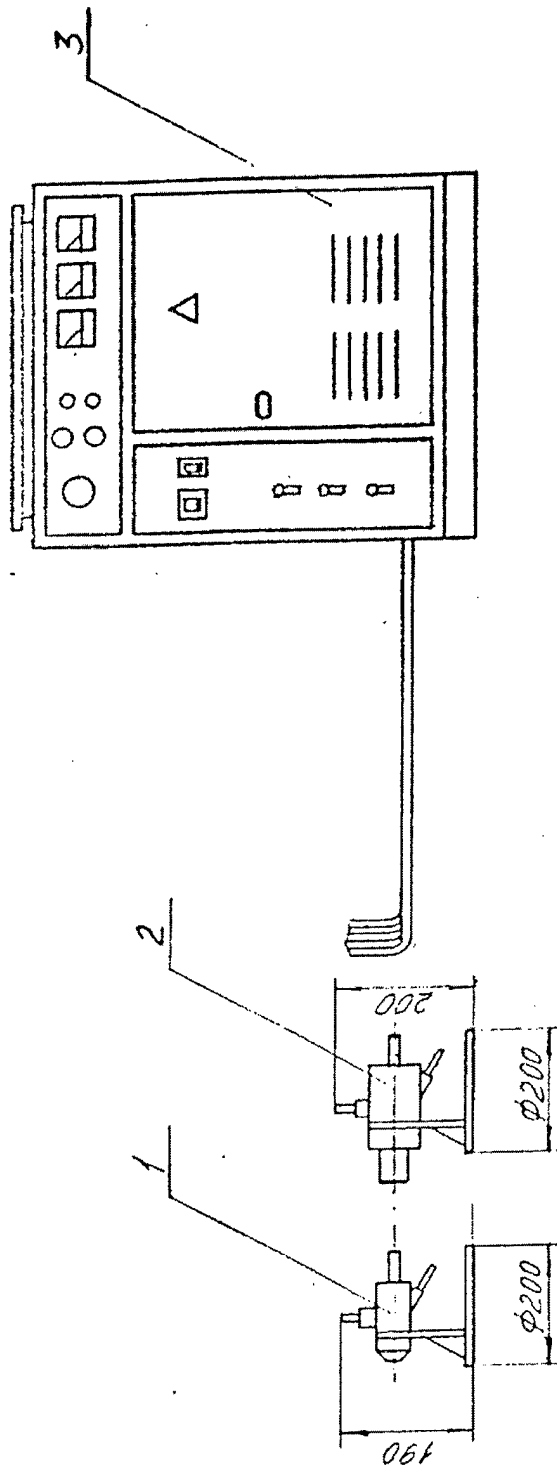

Fig. 1

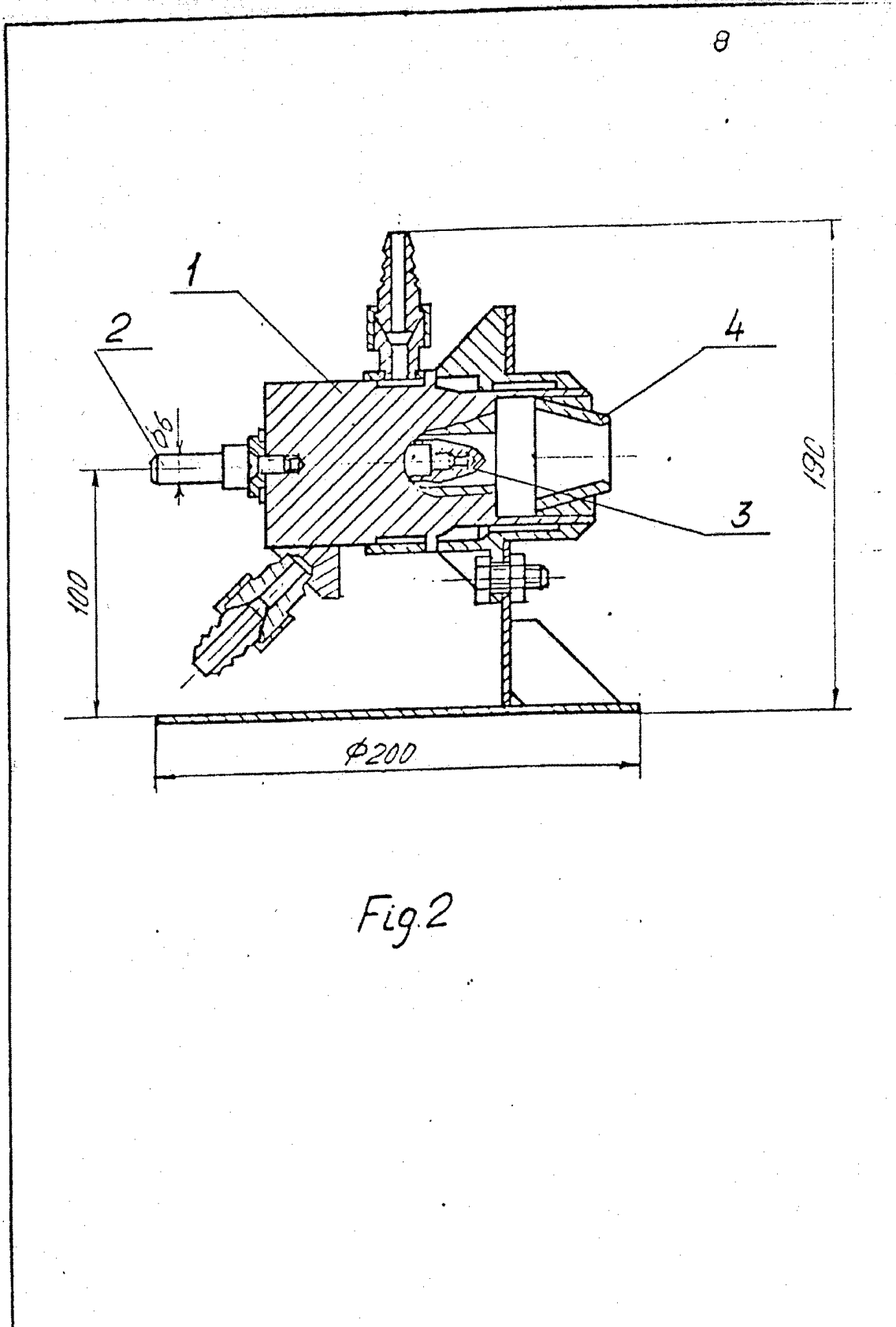

Fig. 2

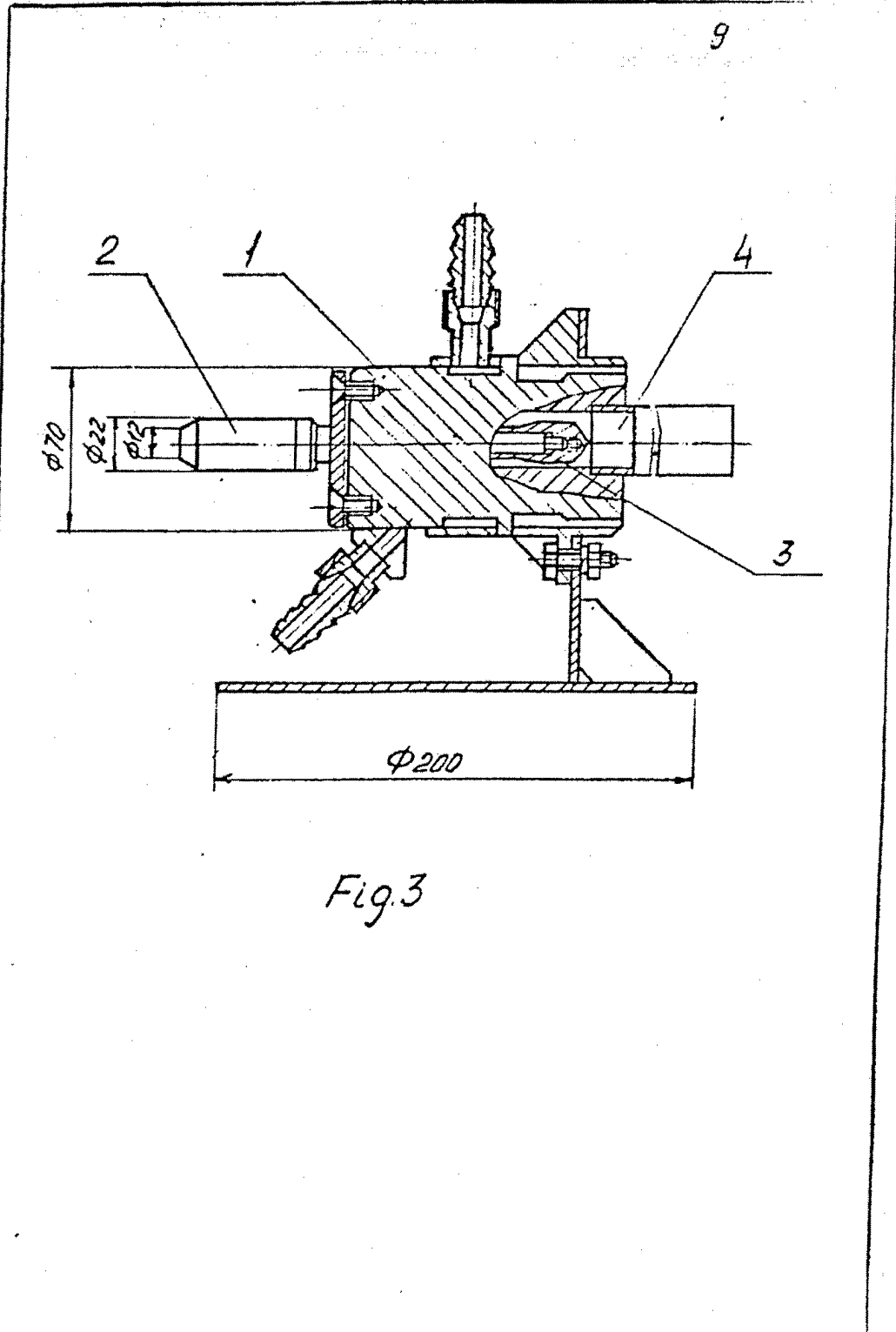
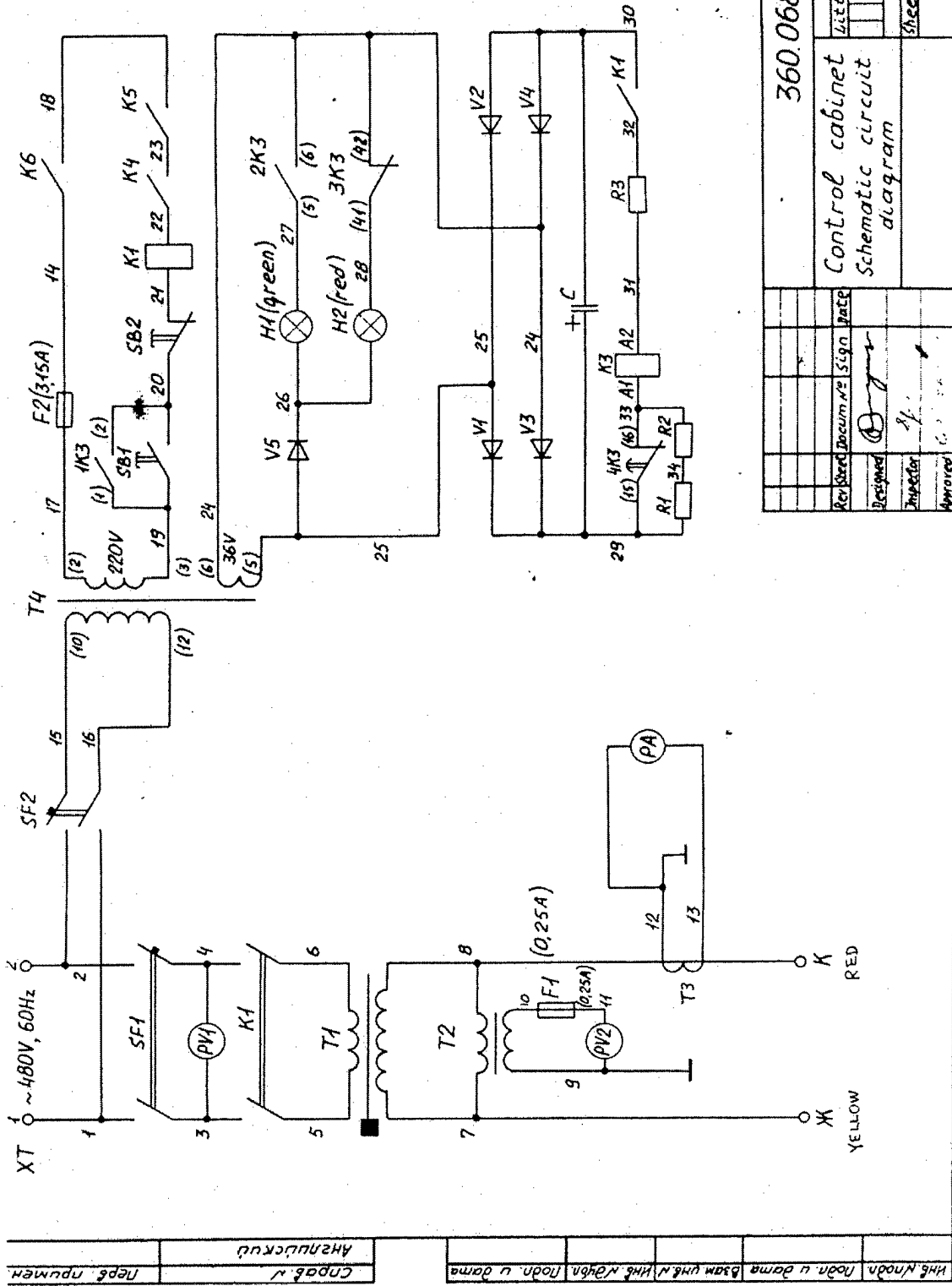

Fig. 3

Table of diameters of orifice plates (mm)

| Air flow rate, g/sec | Pressure orifice plate, atm | | | | |
|----------------------|-----------------------------|-----|-----|-----|------|
| | 3 | 4 | 5 | 6 | 7 |
| 0.5 | 0.9 | 0.8 | 0.7 | 0.6 | 0.58 |
| 1 | 1.3 | 1.1 | 1.0 | 0.9 | 0.8 |
| 2 | 1.8 | 1.6 | 1.4 | 1.3 | 1.2 |
| 3 | 2.2 | 1.9 | 1.7 | 1.6 | 1.4 |
| 4 | 2.5 | 2.2 | 2.0 | 1.8 | 1.7 |
| 5 | 2.8 | 2.5 | 2.2 | 2.0 | 1.9 |
| 6 | 3.1 | 2.7 | 2.4 | 2.2 | 2.0 |
| 7 | 3.4 | 2.9 | 2.6 | 2.4 | 2.2 |
| 8 | 3.6 | 3.1 | 2.8 | 2.5 | 2.4 |
| 9 | 3.8 | 3.3 | 3.0 | 2.7 | 2.5 |
| 10 | 4.0 | 3.5 | 3.1 | 2.8 | 2.6 |



| | | | | | |
|-----------|-----------|-----------|-----------|-----------|-----------|
| Имя Клода | Имя Клода | Имя Клода | Имя Клода | Имя Клода | Имя Клода |
| Имя Клода | Имя Клода | Имя Клода | Имя Клода | Имя Клода | Имя Клода |
| Имя Клода | Имя Клода | Имя Клода | Имя Клода | Имя Клода | Имя Клода |

| | | | |
|-------------------|-----------|-----------|-----------|
| 360.06833 | | Имя Клода | Имя Клода |
| Control cabinet | | Имя Клода | Имя Клода |
| Schematic circuit | | Имя Клода | Имя Клода |
| diagram | | Имя Клода | Имя Клода |
| Имя Клода | Имя Клода | Имя Клода | Имя Клода |
| Имя Клода | Имя Клода | Имя Клода | Имя Клода |
| Имя Клода | Имя Клода | Имя Клода | Имя Клода |
| Имя Клода | Имя Клода | Имя Клода | Имя Клода |

| Справ. № | Перв. примен. | | | | | | | | | | | | | | | | | | | | | | |
|--------------|------------------|---|------|-----------------|--|-------|--------|------|------|-------|--|----------|--------|-------|--------|----------|---------------|---|--|---|------------------|---|--|
| АНГЛИЙСКИЙ | | | | | | | | | | | | | | | | | | | | | | | |
| Инв. № дубл. | Подп. и дата | <table border="1" style="width: 100%; border-collapse: collapse;"> <thead> <tr> <th style="width: 15%;">Position</th> <th style="width: 55%;">Name</th> <th style="width: 10%;">Quant</th> <th style="width: 20%;">Remark</th> </tr> </thead> <tbody> <tr> <td>BH1, BH2</td> <td>Closing valve</td> <td style="text-align: center;">1</td> <td></td> </tr> <tr> <td>П</td> <td>Plasma generator</td> <td style="text-align: center;">1</td> <td></td> </tr> </tbody> </table> | | | | | | | | | | Position | Name | Quant | Remark | BH1, BH2 | Closing valve | 1 | | П | Plasma generator | 1 | |
| Position | Name | | | | | | | | | | | Quant | Remark | | | | | | | | | | |
| BH1, BH2 | Closing valve | 1 | | | | | | | | | | | | | | | | | | | | | |
| П | Plasma generator | 1 | | | | | | | | | | | | | | | | | | | | | |
| Инв. № дубл. | Подп. и дата | 360.068Г3 | | | | | | | | | | | | | | | | | | | | | |
| Designed | Docum N | Sign | Date | Control cabinet | | | | Litt | Mass | Scale | | | | | | | | | | | | | |
| Inspector | Approved | Principal hydraulic scheme | | | | Sheet | Sheets | | | | | | | | | | | | | | | | |

360068X3

Перв. примен.
 Английский

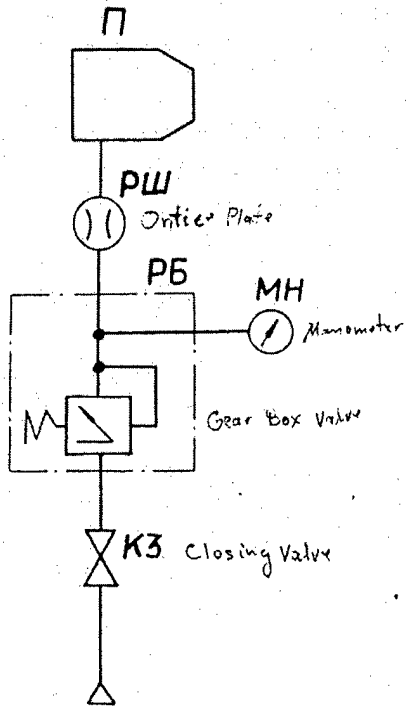

Подп. и дата
 Взам. инв. и инв. №
 Подп. и дата
 Подп. и дата

| Position | Name | Quant | Remark |
|----------|------------------|-------|--------|
| КЗ | Closing valve | 1 | |
| МН | Manometer | 1 | |
| П | Plasma generator | 1 | |
| РБ | Gear box valve | 1 | |
| РШ | Orifice plate | 1 | |
| | | | |
| | | | |

360.068X3

| Per Sheet | Docum N | Sign | Date | Control cabinet | Lite | Mass | Scale |
|-----------|---------|--------------------|------|----------------------|------|------|-------|
| Designed | | <i>[Signature]</i> | | Principal gas scheme | | | |

SINGLE PHASE PLASMA GENERATOR
OF POWER SUPPLY SYSTEM

CERTIFICATE

2BG. 790. 001 PS

CONTENTS

| | Page |
|---|------|
| 1. General information on the product | 3/5 |
| 2. Technical description and main characteristics | 3/5 |
| 3. Delivery set | 4/5 |
| 4. Acceptance certificate | 5/5 |
| 5. Information on preservation and packing..... | 5/5 |

1. GENERAL INFORMATION ON THE PRODUCT

1.1. 1-phase plasma generator of power supply system, hereinafter referred to as "Device", was made by JSC "Sila", factory No _____.

1.2. Device is used for producing gas high-temperature streams.

2. TECHNICAL DESCRIPTION AND MAIN CHARACTERISTICS

- 2.1. Kind of current alternating;
- 2.2. Operating current (OUTPUT) $1 \rightarrow 10$ A;
- 2.3. Power supply voltage : primary 480 V;
secondary 6000 V;
- 2.4. Cos f $0.1 \rightarrow 0.3$;
- 2.5. Working fluid - air :
 - 2.5.1. Control cabinet inlet pressure 0.5 MPa; (~ 7.5 P)
 - 2.5.2. Flow rate $0.5 \rightarrow 5$ g/sec;
- 2.6. Cooling air, water;
- 2.7. Overall dimensions should not exceed the following:
 - 2.7.1. Plasma generator PD-6: length 200 mm;
diameter 140 mm;
 - 2.7.2. Plasma generator PD-7: length 350 mm;
diameter 140 mm;
 - 2.7.3. Control cabinet: length 1120 mm;
width 800 mm;
height 1410 mm.
- 2.8. Mass of the device, not more 710 kg.

3. DELIVERY SET

| Code | Name | Q-ty |
|------------------------------|---|------|
| Stationery set | | |
| B053.00.00 | 1-phase alternating current plasma generator PO-6 | 1 |
| B054.00.00 | 1-phase alternating current plasma generator PO-7 | 1 |
| 6BG.360.068-01 | Control cabinet | 1 |
| 2BG.790.001 TO | Technical description of 1-phas plasma generator | 1 |
| 2BG.790.001 PS | 1-phase plasma generator certificate | 1 |
| Connecting parts | | |
| 5BG.462.007-01 | Gas Hose | 1 |
| 5BG.462.008-01 | Water Hose | 2 |
| 5BG.510.018 | Connecting wire | 2 |
| 5BG.640.015-01 | Magnetic Core | 2 |
| 5BG.263.067 | Guide | 4 |
| 8BG.950.491 | Washer | 1 |
| 8BG.950.491-01 | Washer | 1 |
| 8BG.950.491-02 | Washer | 1 |
| 8BG.950.491-03 | Washer | 1 |
| 8BG.950.491-04 | Washer | 1 |
| 8BG.950.491-05 | Washer | 1 |
| Spares for plasma generators | | |
| B054.00.03-01 | Tube | 2 |
| -02 | Tube | 2 |
| Control cabinet spare parts | | |
| KM24-90 24B | Lamp | 4 |
| VPB6-28, 0,25A | Fuse Link | 1 |
| VPB6-37, 3,15A | Fuse Link | 1 |
| 8BG.156.478 | Gasket | 1 |
| 8BG.156.478-01 | Gasket | 4 |
| AKPU301.532.002-02 | Hose clip | 2 |
| AKPU301.532.002-01 | Hose clip | 2 |
| 8BG.454.122 | Nipple | 6 |
| 8BG.454.123 | Nipple | 3 |
| 8BG.946.086 | Nut | 9 |

5/5

4. ACCEPTANCE CERTIFICATE

1-phase plasma generator of power supply system (factory
No 1006) conforms to the technical documentation and
recognized fit for the use.

Date of producing

04.07.95

Representative of
Checking Department

O T K

[Signature]

5. INFORMATION ON PRESERVATION AND PACKING

1-phase plasma generator of power supply system is preserved
and packed in accordance with the technical documentation.

Date of preservation

04.07.95

Preserved by

[Signature]

Packed by

Appendix C.
Plasma Waste Processing System Demonstration
Design Sketch

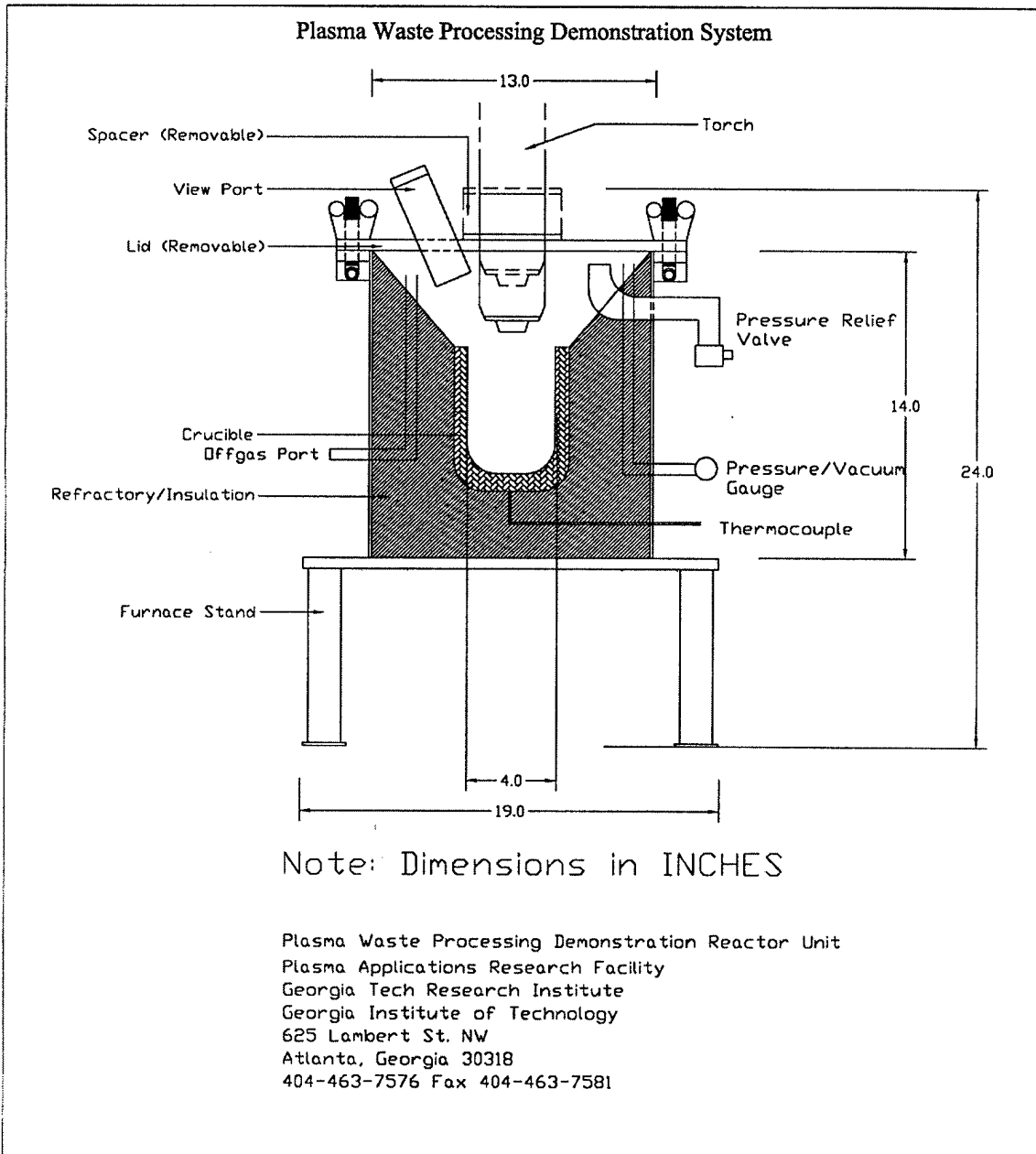

Appendix D.
Crucible Information

Crucible Information

#6 Clay Graphite Crucible

Dimensions:

6-3/4" High

5-9/16" Top Diameter

3-7/8" Bottom Diameter

Refractory for Crucible

#1007

RKS 3000 Degree F Castable

Vendor:

Budget Casting Supply LLC

60 East 40th Ave

Unit C

San Mateo, California 94403

650-345-3891

Crucible With Refractory



Crucible Modified With Spout & Installed in Refractory

Appendix E.
View Port Details

View Port Lens Information

Pyrex Glass Circles

Size: 2 Inch Diameter, 0.125 inch Thickness

Vendor: Mc Master-Carr Supply Company

A- PO Box 740100

Atlanta, GA 30374-0100

Phone: 404-346-7000

Fax 404-349-9091

View Part Assembly

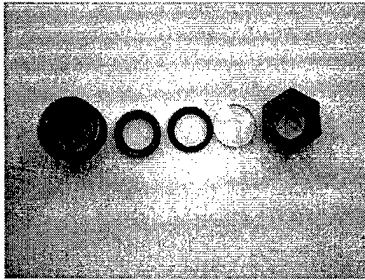

Parts

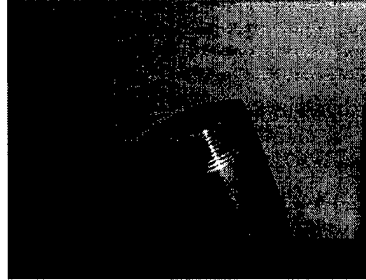

Mounting Column



Outside Ring

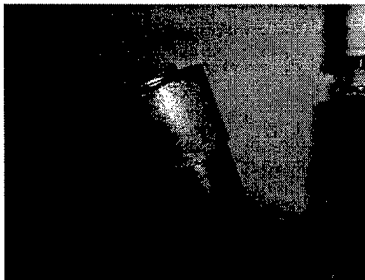

Outside Ring On Column

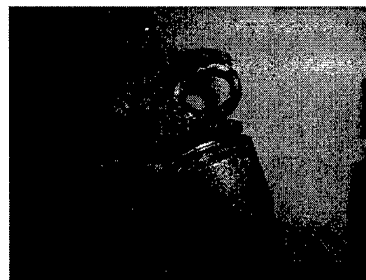

Gasket



Gasket Inserted In Column

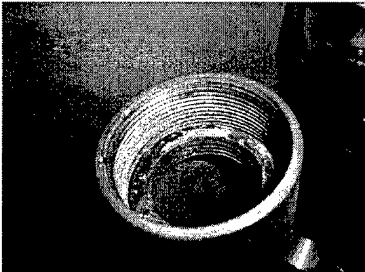

Ready For Lens



Lens Insertion



Lens Insertion

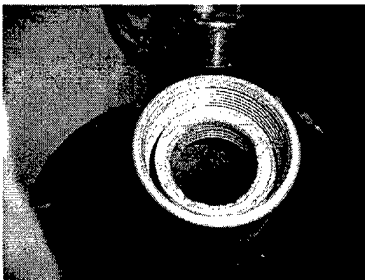

Lens Inserted

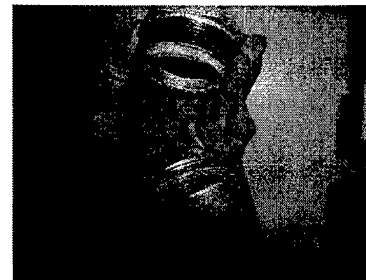

Top Mount

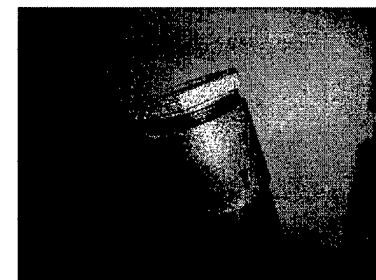

Complete Installed Lens

Appendix F.
Torch Connections

Torch Connections

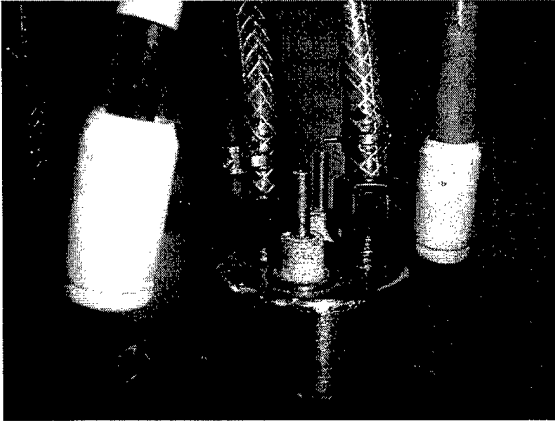

Torch Cooling Cable Connected and Power Cables Disconnected



Torch Cable Lid Bracket

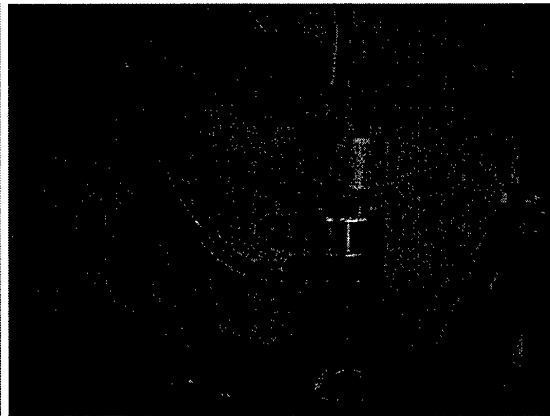

Torch With All Connections Completed

Appendix G.
Reactor Seal Information

Torch Sealing Gasket

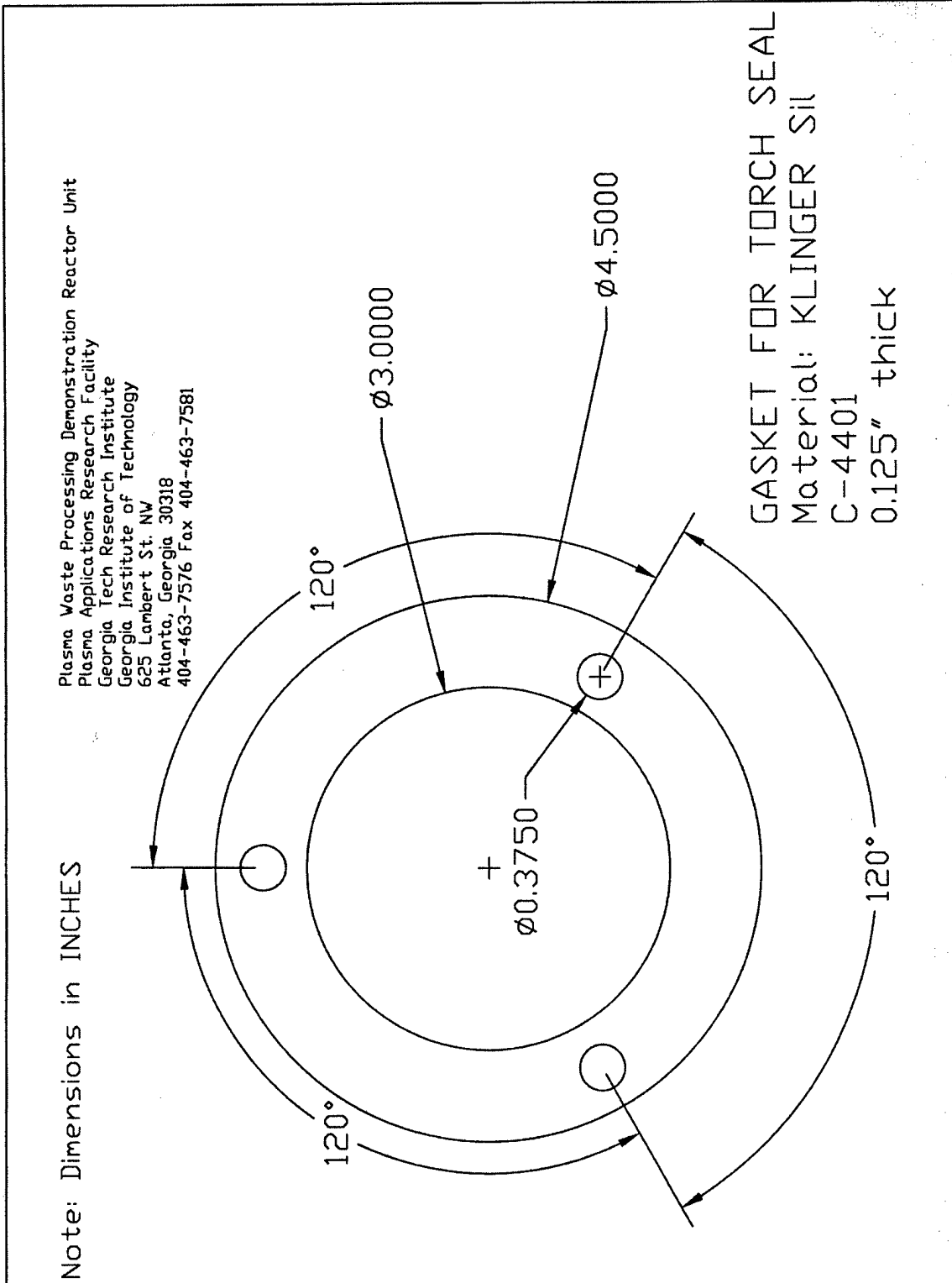

Torch Gasket Seal Details

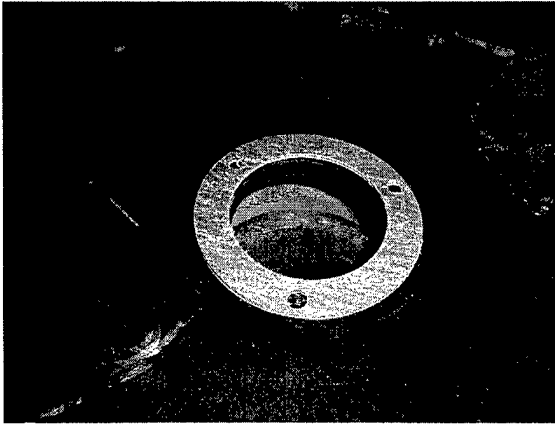

First Gasket

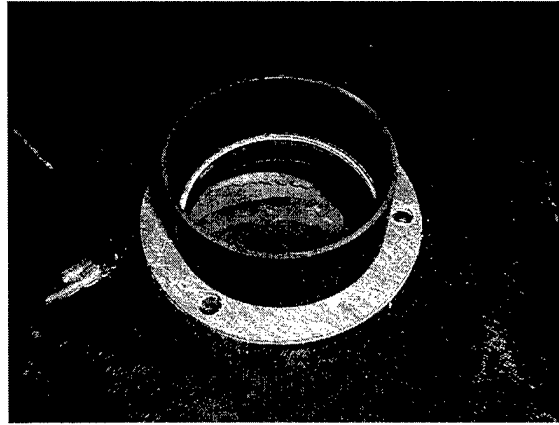

Space (as needed for torch position)



Second Gasket (On Spacer)

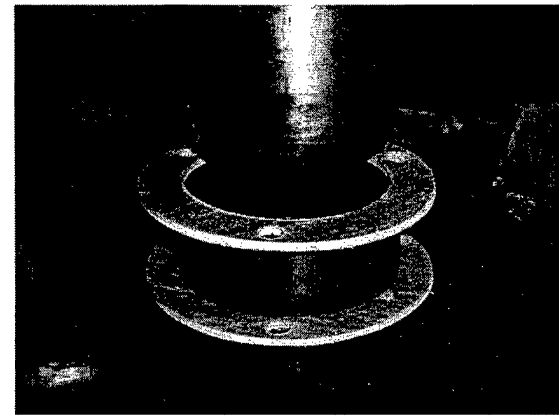

Torch Insertion

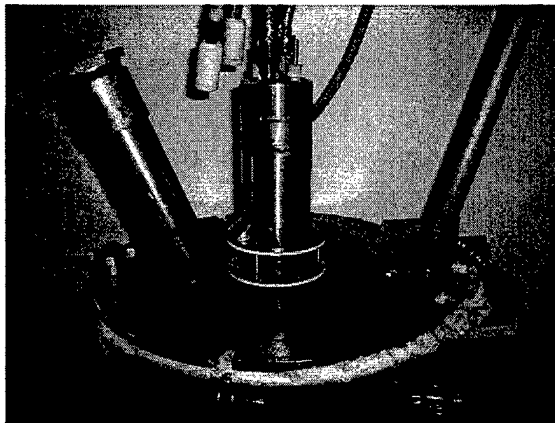

Torch In Reactor With Spacer

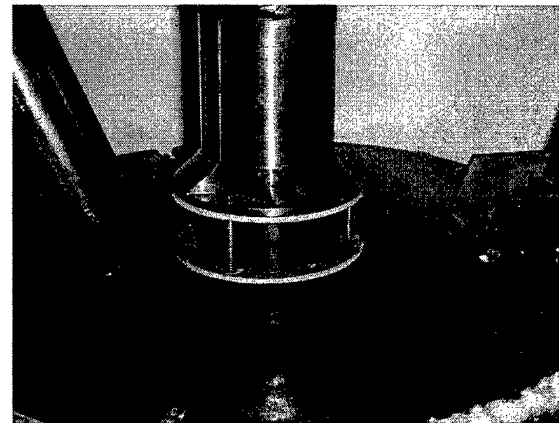

Close Up Of Torch In Reactor Lid

Appendix H.
Thermocouple Information

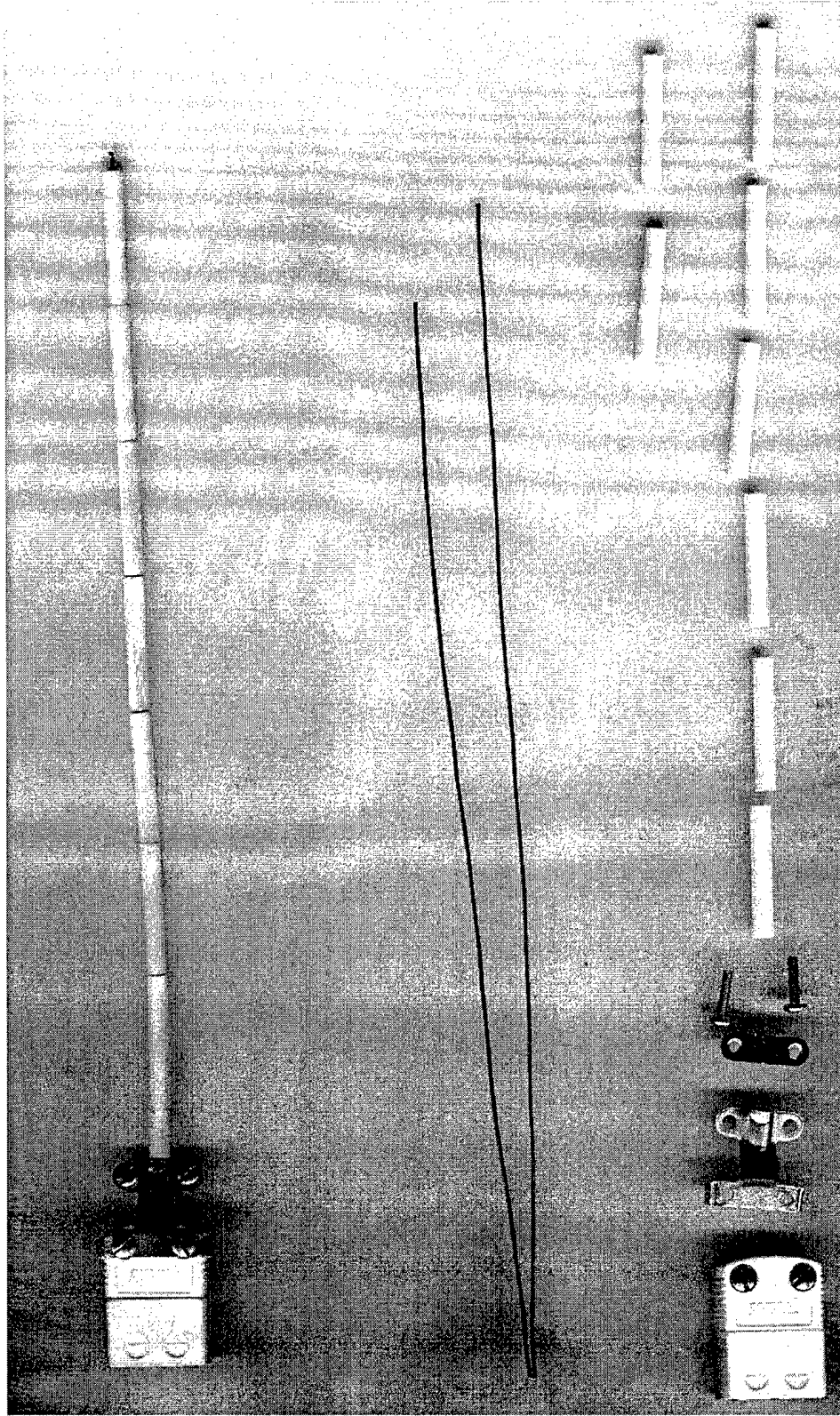

Thermocouple Unit (assembled, wire thermocouple, parts)

Thermocouple Removal Details

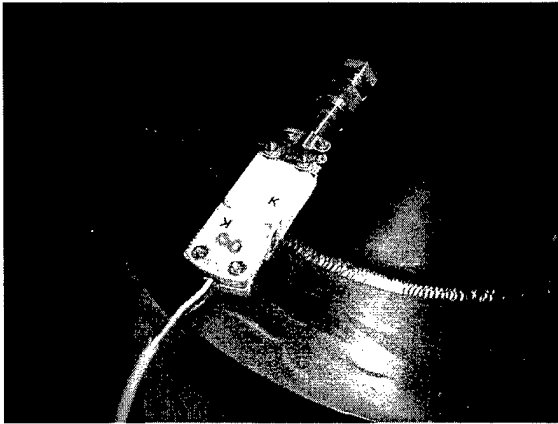

Connector

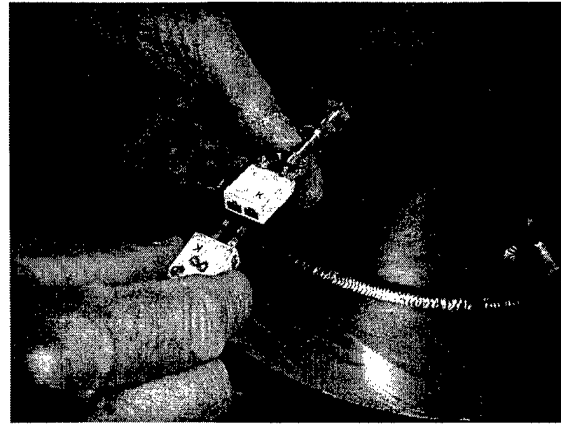

Disconnect

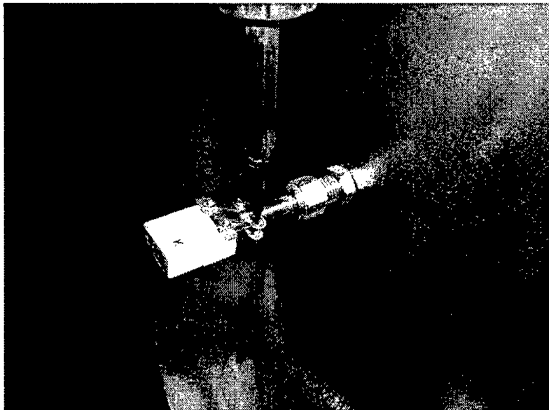

Loosen Screws

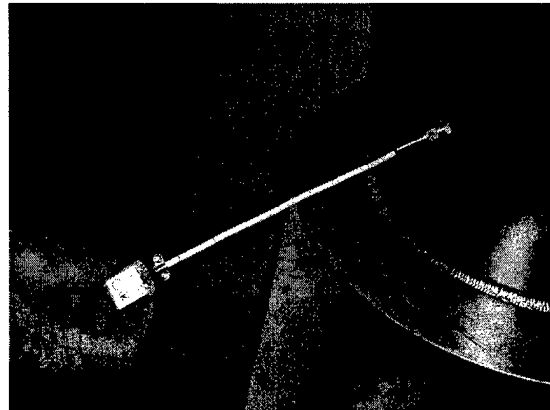

Remove Thermocouple

Appendix I.

Monthly Report Accomplishments

Monthly Report Accomplishments

October 2000

1. A project meeting is scheduled at the Georgia Tech Plasma Applications Research Facility on November 3, 2000 with the AF project technical contact, the Scientific Utilization, Inc (SUI) representative, and the Georgia Tech research team. The purpose of the meeting will be to discuss the requirements and specifications for the system to be delivered to AFRL/MLQ.
2. In October, the Plasma Applications Research Facility received a 5 kW plasma system from SUI for preliminary installation and setup. The installation and setup was completed and the system is being evaluated. The initial finding indicated that a higher power level torch might be needed. Discussions with SUI for a 15 kW unit and readjustment of the power supply are planned.
3. The development of a demonstration furnace has begun. The furnace specifications will accommodate up to a 15 kW plasma torch from SUI and will have a view port for process inspection during the demonstration.

November 2000

1. A project meeting and plasma demonstration was conducted at the Georgia Tech Plasma Applications Research Facility on November 3, 2000 with the AF project technical contacts, the Scientific Utilization, Inc (SUI) representative, and the Georgia Tech research team. During the meeting, discussions consisted of preliminary planning and scheduling for the program. Specifications for the system, and specific facility requirements that AFRL/MLQ will need to provide for site installation. These will be provided during January 2001.
2. In November, the Plasma Applications Research Facility upgraded the 5 kW plasma torch with a 15 kW plasma torch unit from SUI. This required readjustment and calibration of the power supply by SUI.

3. The development of a demonstration furnace is progressing. The furnace specifications will accommodate up to a 15 kW plasma torch from SUI and will have a view port for process inspection during the demonstration. Parts and fabrication will begin in December 2000.

December 2000

1. Acquisition of parts for the furnace fabrication started in December 2000.
2. The furnace fabrication and assembly was also started and will continue in January 2001.

January 2001

1. In January 2001, the furnace fabrication progressed on schedule.
2. The lid unit fabrication was completed.
3. Installation of the crucible refractory material in the base of the furnace was completed.
4. A furnace offgas port, a replaceable thermocouple port, a pressure/vacuum port with gauge, and a pressure release valve were installed in the unit.
5. The torch will be installed in the furnace lid with fixed spacers that can be changed to vary the depth into the furnace chamber.
6. The furnace chamber has a removable crucible that is recessed into the refractory.
7. The requirements for the facility installation were identified.

February 2001

1. During February the furnace fabrication progressed on schedule.
2. A modification to hold the connections (power, water, gas pressure) to the torch

was incorporated into the lid.

3. Additional installation of the crucible refractory material in the top area of the furnace is planned in March.
4. This additional refractory material will allow better insulation of the thermal radiation during the experiments

March 2001

1. During March the furnace fabrication and assembly progressed on schedule.
2. The installation of additional crucible refractory material in the top area of the furnace was completed in March.
3. This additional refractory material allows better insulation of the thermal radiation during the experiments.
4. A thermocouple monitor unit was procured and has been delivered for the system.

April 2001

1. During April the final refractory material was installed in the furnace. A thermocouple and associated monitor unit was installed for the system.

2. A 90-day no cost contractual extension due to scheduling and facility preparation was completed and approved in April.
3. A program review meeting was held on April 24, 2001 at the Georgia Tech Plasma Applications Research Facility. The meeting agenda consisted of:
 - Review of the plasma programs.
 - Status of the processing unit.
 - System requirements (defined in item #4).
 - Schedule and procedure for system delivery.
 - On-site setup and training with documentation.
 - Demonstration of the plasma processing system.

May 2001

1. During the May 2001 performance period, a draft of the User and Operational Manual (Training Document) was in preparation for the system.
2. The Plasma Waste Processing Demonstration System was picked up and transported to Tyndall, AFB on May 16, 2001.

June 2001

1. During the June 2001 performance period, a draft of the User and Operational/Training Document was completed.
2. The Plasma Waste Processing Demonstration System was successfully setup and operated the week of June 11, 2001 by the Plasma Applications Research Facility Staff.
3. The on-site visit also included training for the AF staff.