

NAVAL POSTGRADUATE SCHOOL

Monterey, California



THESIS

**AN ENTERPRISE INFORMATION PORTAL FOR
CROSS-UNIT COLLABORATION IN
BOTSWANA DEFENCE FORCE**

by

Moemedi Bini Ramorathudi

March 2002

Thesis Advisor:
Associate Advisor:

William Haga
John Osmundson

Approved for public release; distribution is unlimited

REPORT DOCUMENTATION PAGE			Form Approved OMB No. 0704-0188	
Public reporting burden for this collection of information is estimated to average 1 hour per response, including the time for reviewing instruction, searching existing data sources, gathering and maintaining the data needed, and completing and reviewing the collection of information. Send comments regarding this burden estimate or any other aspect of this collection of information, including suggestions for reducing this burden, to Washington headquarters Services, Directorate for Information Operations and Reports, 1215 Jefferson Davis Highway, Suite 1204, Arlington, VA 22202-4302, and to the Office of Management and Budget, Paperwork Reduction Project (0704-0188) Washington DC 20503.				
1. AGENCY USE ONLY (Leave blank)		2. REPORT DATE March 2002	3. REPORT TYPE AND DATES COVERED Master's Thesis	
4. TITLE AND SUBTITLE: An Enterprise Information Portal for Cross-Unit Collaboration in the Botswana Defence Force.			5. FUNDING NUMBERS	
6. AUTHOR Ramorathudi, Moemedi B.				
7. PERFORMING ORGANIZATION NAME(S) AND ADDRESS(ES) Naval Postgraduate School Monterey, CA 93943-5000			8. PERFORMING ORGANIZATION REPORT NUMBER	
9. SPONSORING /MONITORING AGENCY NAME(S) AND ADDRESS(ES) N/A			10. SPONSORING/MONITORING AGENCY REPORT NUMBER	
11. SUPPLEMENTARY NOTES The views expressed in this thesis are those of the author and do not reflect the official policy or position of the Department of Defense or the U.S. Government.				
12a. DISTRIBUTION / AVAILABILITY STATEMENT Approved for public release; distribution is unlimited.)			12b. DISTRIBUTION CODE	
13. ABSTRACT (maximum 200 words) This thesis discusses the need for an information technology system to facilitate cross-unit collaboration in the Botswana Defence Force (BDF). The existing traditional means of communication and information sharing among the BDF units and bases do not meet the present requirements and may negatively impact productivity and mission readiness in the BDF. The thesis begins with a background discussion of the communication problems in the BDF and examines the problem in the context of designing and implementing an Enterprise Information Portal (EIP). This would facilitate the collaboration and the flow of information within and among units throughout different regions in Botswana. The approach to the problem involves defining an EIP, evaluating the benefits of an EIP and assessing technologies critical to implementing an EIP. After defining an EIP, a business plan is presented to provide a guideline for implementing the Botswana Defence Force Enterprise Information Portal (BDF-EIP). The thesis further discusses organizational challenges that may affect implementing the BDF-EIP. These organizational issues include a discussion on change, change management and champion.				
14. SUBJECT TERMS Enterprise Information Portal (EIP), business case, BDF-EIP, change, change management, change agent, champion.			15. NUMBER OF PAGES 71	
			16. PRICE CODE	
17. SECURITY CLASSIFICATION OF REPORT Unclassified	18. SECURITY CLASSIFICATION OF THIS PAGE Unclassified	19. SECURITY CLASSIFICATION OF ABSTRACT Unclassified	20. LIMITATION OF ABSTRACT UL	

NSN 7540-01-280-5500

Standard Form 298 (Rev. 2-89)
Prescribed by ANSI Std. Z39-18

THIS PAGE INTENTIONALLY LEFT BLANK

Approved for public release; distribution is unlimited

**AN ENTERPRISE INFORMATION PORTAL FOR CROSS-UNIT
COLLABORATION IN THE BOTSWANA DEFENCE FORCE**

Moemedi Bini Ramorathudi
Lieutenant, Botswana Defence Force (BDF)
B.A., University of Botswana, 1998

Submitted in partial fulfillment of the
requirements for the degree of

MASTER OF SCIENCE IN INFORMATION TECHNOLOGY MANAGEMENT

from the

**NAVAL POSTGRADUATE SCHOOL
March 2002**

Author: Moemedi Bini Ramorathudi

Approved by: William Haga, Thesis advisor

John Osmundson, Associate Advisor

Dan C. Boger, Chairman
Computer and Information Systems/C3 Academic Groups

THIS PAGE INTENTIONALLY LEFT BLANK

ABSTRACT

This thesis discusses the need for an information technology system to facilitate cross-unit collaboration in the Botswana Defence Force (BDF). The existing traditional means of communication and information sharing among the BDF units and bases do not meet the present requirements and may negatively impact productivity and mission readiness in the BDF. The thesis begins with a background discussion of the communication problems in the BDF and examines the problem in the context of designing and implementing an Enterprise Information Portal (EIP). This would facilitate the collaboration and the flow of information within and among units throughout different regions in Botswana. The approach to the problem involves defining an EIP, evaluating the benefits of an EIP and assessing technologies critical to implementing an EIP. After defining an EIP, a business plan is presented to provide a guideline for implementing the Botswana Defence Force Enterprise Information Portal (BDF-EIP). The thesis further discusses organizational challenges that may affect implementing the BDF-EIP. These organizational issues include a discussion on change, change management and champion.

THIS PAGE INTENTIONALLY LEFT BLANK

TABLE OF CONTENTS

I.	INTRODUCTION.....	1
A.	BACKGROUND.....	1
	1. The Problem.....	1
	2. Proposed Solution.....	1
	3. The Effect if EIP Not Implemented	2
B.	PURPOSE	2
C.	BENEFITS OF THE STUDY.....	3
D.	METHODOLOGY	3
E.	CHAPTER OUTLINE.....	3
II.	LITERATURE REVIEW OF EIP.....	5
A.	INTRODUCTION.....	5
B.	EIP DEFINED	5
C.	EIP FUNCTIONALITIES.....	5
	1. Single Point of Access to Organizational Information Resources.....	5
	2. Personalization	6
	3. Collaboration	6
	4. Mobility	6
	5. Scalability.....	6
	6. Reliability.....	7
	7. Security.....	7
	<i>a. Physical Security</i>	<i>7</i>
	<i>b. Network Security</i>	<i>7</i>
	<i>c. Operating Systems/Application/Databases Security</i>	<i>8</i>
D.	THE BENEFITS OF AN EIP FOR THE BDF.....	8
	1. Improved Productivity.....	8
	2. Improved Effectiveness.....	8
	3. Improved Collaboration and Information Sharing	8

4.	Universal Access to Organizational Resources.....	9
E.	EIP TECHNOLOGIES AND BUILDING BLOCKS.....	9
1.	Local Area Network (LAN).....	9
2.	Wide Area Network (WAN).....	11
3.	Wireless LAN and Wireless WAN.....	11
4.	Intranet/Extranet	12
F.	MILITARY STRUCTURE VERUS CORPORATE STRUCTURE.....	13
III.	THE BUSINESS CASE FOR THE BOTSWANA DEFENCE FORCE ENTERPRISE INFORMATION PORTAL (BDF-EIP)	17
A.	PHASE 1: CONCEPTUAL BUSINESS LEVEL	18
1.	History and Composition of the BDF	18
a.	<i>BDF-HQ</i>	19
b.	<i>Combat Elements</i>	19
c.	<i>Combat Support</i>	19
d.	<i>Combat Support Services</i>	20
e.	<i>Air Arm</i>	20
2.	The Plan	20
a.	<i>Purpose</i>	20
b.	<i>Process</i>	21
c.	<i>Scope</i>	21
3.	Organizational Direction	21
a.	<i>Mission Statement</i>	21
b.	<i>Vision</i>	22
c.	<i>Values</i>	22
d.	<i>Goals</i>	22
e.	<i>Objectives</i>	22
f.	<i>Priorities</i>	23
4.	Requirements Analysis	23
a.	<i>The Need for Connectivity</i>	24
b.	<i>Environmental Requirements</i>	24

	c.	<i>External Requirements</i>	24
	5.	Operating Vision	25
B.		PHASE 2: DETAILED BUSINESS ANALYSIS.....	25
	1.	Information Needs.....	25
	2.	Business Process	25
	3.	Business Requirements	26
C.		PHASE 3: CONCEPTUAL INFORMATION SYSTEM PLAN AND VISION.....	26
	1.	Current information System in the BDF – Internal.....	26
	2.	Current Information System Situation – External	27
	3.	Portal Computing Architecture for BDF-EIP	27
		a. <i>Openness</i>	27
		b. <i>Interoperability</i>	28
		c. <i>Scalability</i>	28
	4.	Service Architecture.....	28
	5.	Policies and Responsibilities.....	29
D.		PHASE 4: OPTION ANALYSIS AND ACTION PLAN.....	29
	1.	In-house Building	30
	2.	Buying.....	30
	3.	Outsourcing.....	31
	4.	Risk Analysis.....	31
	5.	Design and Architecture	32
IV.		CHANGE MANAGEMENT PROCESS.....	33
	A.	INTRODUCTION.....	33
	B.	CHANGE	33
	C.	TYPES OF CHANGE.....	34
		1. Developmental (Incremental) Change.....	34
		2. Transitional Change.....	35
		3. Transformational Change	35
	D.	CHANGE STRATEGIES.....	37

1.	Directive/Top-Down Strategies	37
2.	Bottom-up Strategies.....	37
3.	Cross Section (Participative) Strategies	38
E.	CHANGE MANAGEMENT	38
1.	Organizational History and Politics	40
a.	<i>Culture</i>	40
2.	Management and Organization	43
3.	People.....	43
4.	Resistance to Change	44
F.	CHANGE AGENT	45
G.	CHAMPION	45
H.	PLANNING CHANGE/IMPLMENTATION	45
1.	Determining the Need or Desire for a Change	46
2.	Preparing Tentative Plans.....	46
3.	Analyzing Probable Reactions	47
4.	Making a Final Decision	47
5.	Establishing a Timetable	47
6.	Communicating the Change.....	47
7.	Implementing the Change (BDF-EIP).....	48
V.	CONCLUSION AND RECOMMENDATIONS	49
A.	CONCLUSION.....	49
B.	RECOMMENDATIONS.....	49
	LIST OF REFERENCES	51
	INITIAL DISTRIBUTION LIST	55

LIST OF FIGURES

Figure 2.1: Bus topology connecting each computer to a single wire.	10
Figure 2.2: Star topology connecting all to computers to hub.	10
Figure 2.3: Ring topology connecting computers in a closed loop shape.....	10
Figure 2.4: Mesh topology interconnecting computers between networks.....	10
Figure 2.6: Wide Area Network (WAN) topology.	11
Figure 2.7: Wireless LAN.....	12
Figure 2.8: Wireless WAN	12
Figure 2.9: Corporate structure	13
Figure 2.10: Military Organizational Structure.....	14
Figure 3.1: Business Case Contents	18
Figure 3.2: A BDF-EIP covering all Major Bases.	32
Figure 4.1: Matrix of the Three Types of Organizational Change	36
Figure 4.2: Components of Corporate Culture.....	39
Figure 4.3: Levels of Culture	42
Figure 4.4: A Manager's Model for Change	46

THIS PAGE INTENTIONALLY LEFT BLANK

ACKNOWLEDGMENTS

I am indeed grateful to the following individuals who provided support and made this research possible: professors, William Haga and John Osmundson for their invaluable guidance, encouragement and above all their patience throughout the entire research and writing. Editor: Beth Summe for making this document readable. Finally, I want to thank my mother L. S. Mare and a dear friend Masa for keeping my spirits high throughout my stay in the U.S.A.

THIS PAGE INTENTIONALLY LEFT BLANK

I. INTRODUCTION

A. BACKGROUND

1. Problem

Cross-unit collaboration and flow of information in the Botswana Defence Force (BDF) are important for facilitating information-sharing for command and control purposes and for providing an easy flow of information among units and bases in different locations in Botswana. In addition, timely, accurate and a secure flow of information is vital for tactical, operational and strategic decision-making. With the proliferation of information technology, the traditional modes of collaboration, such as postal services, the circulation of memos, telephone calls, faxes and personal messengers do not meet the present requirements. The delays associated with transmitting and retrieving of information stored in paper-based forms, such as manuals, memos, newsletters and handbooks undermine productivity in the BDF, which impact the overall mission readiness. In a similar way, the loss of time associated with frequent and lengthy meetings and the cost associated with telephone usage are likely to increase through such modes of communication.

2. Proposed Solution

In order to leverage the abundance of information technology, the BDF should adopt an Enterprise Information Portal (EIP). A portal is an amalgamation of technologies (software and infrastructure) that work together to aggregate a selected subset of information into a central location (Collins, 2001). Moreover, it is designed to facilitate collaboration and to ease the flow of information in an organization. Planning and managing the flow of information throughout the BDF could minimize labor, data redundancy and inconsistency, while improving the quality and accuracy of the information needed for decision-making process. The envisioned result would be to make the BDF more responsive, efficient and effective. The extensive analysis of an EIP will be addressed in the literature review.

A portal is a solution when an organization needs to share information among employees, to locate information difficult to find, to push information to the users or to create a central location to navigate the data to benefit employees. When looking at how an organization can leverage knowledge for better, faster, more consistent and more informed decisions, some operational and strategic issues should be identified. Two such examples are, the employees responsible for completing established tasks on a day-to-day basis face operational issues while the employees responsible for ensuring the overall mission of the organization is met face strategic issues (Collins, 2001). In the military environment, operational issues are the ones encountered by the subordinate commanders and the troops while the higher commanders encounter the strategic issues.

3. Effect if EIP Not Implemented

Not taking advantage of faster, improved tactical decision-making offered by information technology could put the BDF at a disadvantage in carrying out its military missions. Other countries, as noted by Ince, et al. (1997) are creating and implementing information systems for strategic, tactical and command, control, and communication (C³) functions. In the civilian arena, governments and corporations are implementing Management Information Systems (MIS) for strategic and competitiveness. In my view, modern organizations have changed from the “survival of the fittest” to the “survival of the first mover” by exploiting the opportunities through information technology. These organizations are also moving away from paper-based and manual modes of sharing information and collaboration to the paper-less and automated cross-functions and cross-locations collaboration modes of sharing information.

B. PURPOSE

The purpose of this thesis is to investigate and analyze the enterprise information portal (EIP) to foster cross unit collaboration in the BDF. The emphasis is placed on a technology that would be scalable, reliable for providing a real time and a time-critical information to the commanders for a better decision-making process. This study will also address technical and organizational issues, such as change management processes critical to successfully implementing the proposed information systems.

C. BENEFITS OF THE STUDY

This is a first-time study focusing on the feasibility of implementing an information system that link all the units in the BDF enabling them to collaboration. The study also intends to provide guidelines for implementing an EIP in the BDF facilitating a flow of information that is vital to decision-making while enhancing troop mission readiness.

D. METHODOLOGY

This thesis required an extensive literature search of books, journal articles, Internet resources and other materials from the BDF.

E. CHAPTER OUTLINE

Chapter I introduces the research covered in this thesis. It provides an overview of the problem, purpose and benefits of the study as well as the thesis organization.

Chapter II presents an in-depth review of existing literature on Enterprise Information Portal (EIP) and its associated technologies. It specifically deals with the definition of the EIP, EIP functionalities and its benefits. A comparison of how its use in the commercial sector and its relevance to military environment, especially in the BDF, is covered in this chapter. The chapter also discusses EIP components in details and the technological tools involved. The chapter further explains technologies, such as Intranets and Extranets, Local Area Network (LAN) and Wide Area Network providing a clear understanding of infrastructures required for the EIP.

Chapter III addresses the phases of building a case study for the Botswana Defence Force Enterprise Information Portal (BDF-EIP). It also addresses the required analysis for the proposed EIP in the BDF and covers the technical issues involved.

Chapter IV discusses change and change management in order to appreciate the organizational challenges, beside the technological challenges, that are inherent to a successful portal implementation in the BDF. Types of change and change strategies for covered.

Chapter V, the final chapter, concludes with recommendations.

THIS PAGE INTENTIONALLY LEFT BLANK

II. LITERATURE REVIEW OF EIP

A. INTRODUCTION

This chapter examines portal technologies, such as corporate portals (CP), enterprise portals (EP) and enterprise information portals (EIP). These terms are commonly used interchangeably. However, an enterprise portal expands the corporate portal to other roles outside the organization, such as suppliers, vendors and customers (Collins, 2001). The term ‘Enterprise Information Portal’ was first used in a Merrill Lynch report in 1998 (Finkelstein, 2001). The emphasis of the chapter is on the ways in which these technologies could be implemented in a military environment.

B. EIP DEFINED

An EIP is a new application that enables a company to unlock internally and externally stored information, and provides internal and external users with a single gateway to personalized information needed for making informed business decisions (Ferguson, 1999). A slightly different definition by Fitzgerald (2001) describes an EIP as a secure, web-based interface that provide a single point of access to information, applications and services for all people in the enterprise. Each organization can establish its own standard definition along with a collection of portal objectives to the organization when considering a portal strategy (Collins, 2001).

C. EIP FUNCTIONALITIES

An EIP can include but is not limited to the following features and functionalities:

1. Single Point of Access to Organizational Information Resources

The concept of a single point of access to an organizational information resource is crucial when information scattered in different documents and systems are difficult to locate. An EIP provides a logical centralized point to access and share information across different military units and bases in a secured environment.

2. Personalization

Personalization provides required functionality for each user to organize, define and rearrange the portal desktop to work effectively and efficiently. This component is important for creating a working environment that is organized and configured specifically to each employee in the organization optimizing decision-making capabilities (Collins, 2001).

3. Collaboration

An EIP allows users to view and publish information in a group area in order to share internally with colleagues as well as communicate externally with customers, suppliers or partners (Gannon, 2000). These abilities of sharing are accomplished it is through messaging systems, discussion forums and automated alerts (Collins, 2001). This functionality enables real-time interaction and sharing information through establishing a commonplace accessible by all members of the organization (Davydov, 2001). Collaboration in any military organization is essential to provide timely information between commanders and their subordinates within and among units located in various regions.

4. Mobility

With the advent of wireless technology, a mobility feature should be incorporated into an EIP to enable mobile troops to access and share information using cellular phones and personal digital assistants (PDAs). Using wireless LAN and wireless WAN technologies can also enhance mobility feature.

5. Scalability

An EIP must be designed to cope with rapid technological changes and the organization's growing needs. Goodyear et al (2000) explains that scalability is the ability to upgrade and expand software, hardware and network infrastructures to meet changing needs. Scalability must be incorporated into the system from the beginning.

6. Reliability

Reliability is defined as a measure of a system's ability to provide accurate delivery of information (McCabe, 1998). An EIP is a complex system that comprises technologies integrating pieces such as Internet, intranet and extranets (Hall, 2000). Ensuring reliability is important in an EIP. However, measuring accuracy for reliability is difficult; therefore, the running time of the system and the recovery time of a system can provide a surrogate measure of the reliability of that system (McCabe, 1998).

7. Security

Information security is a major concern for all systems and applications that need to protect information resources through controlled access and authorization. Therefore, using identification, authentication and encryption technologies should meet security (Hall, 2000) to handle unclassified and classified data. These are accomplished by issuing access rights to the users, proper storage of software and hardware, and secure network infrastructures. To protect information throughout an enterprise portal security measures for the physical, the network, the operating system, the database and the application, must be integrated into the portal development.

a. Physical Security

Physical security entails controlling access to computers and information resources. Physical security includes guards, locks and fences to deter direct attack and protection against disasters. While being the easiest, the most effective and the least expensive controls, it is the most neglected security component (Pfleegers, 1997).

b. Network Security

Network security controls access through use of firewalls and encryption mechanisms. A firewall is the process that filters all the traffic between a protected network inside the organization and a less protected network from outside the organization. Encryption, on the other hand, is the process of transforming information so that it becomes unintelligible to an outsider observer (Pfleegers, 1997).

c. Operating Systems/Application/Databases Security

These security mechanisms provide an additional security measures, such as logon authentication and access to computer resources.

D. THE BENEFITS OF AN EIP FOR THE BDF

The EIP is becoming mission critical to large enterprises since organizations use this application to give business users' (both within and outside the organization) access to a variety of data sources and applications (Viador Inc, 2000). In the military environment, an EIP can offer the following benefits:

1. Improved Productivity

Improvement in productivity means that a user spends less time to find an answer to a question, to make a decision or to take an action when using an EIP. Spending less time searching for information allows more time using that information. Hence, the portals may speed up the time cycle to process information and to increase efficiency resulting in an overall improvement in productivity (Firestone, 2001).

2. Improved Effectiveness

Improved effectiveness is based on the idea that portals not only give new information that was not previously available to the users, but also provide information in an integrated and personalized form (Firestone, 2001). An EIP is an integrated decision-making system that provides real-time access to relevant information. Accessing relevant information is essential for a successful troop mission, operations and improved effectiveness. Improved effectiveness is an intangible benefit provided by an EIP.

3. Improved Collaboration and Information Sharing

Important benefits of an EIP are improved collaboration within an organization, easy access and dissemination of information across different units.

4. Universal Access to Organizational Resources

An EIP provides access to an organization's information and resources. Given the proper security constraints, users can get information at any location at any time (Cassidy, 1998). In addition, using an EIP creates the possibility using both "pull" and "push" technologies ensuring that users have the right information available to them at the time (Firestone, 2001). Push technology sends information to the users without the user's initiative to seek it while pull technology delivers information only when requested.

E. EIP TECHNOLOGIES AND BUILDING BLOCKS

As mentioned in the definition, an EIP is an amalgamation of technology meant to join an organization's systems and its applications including legacy systems and legacy applications, which improve collaboration and information sharing. Legacy systems and applications are older systems such as computers, hardware, software, application programs that are crucial to the day-to-day operation of an organization but considered old, expensive and unusable (Whitten et al, 2001). However, to build an EIP from the 'ground up' as in the case of the BDF, several technologies that serve as building blocks must be explained. The common building blocks are

- Local Area Network (LAN)
- Wide Area Network (WAN)
- Intranet/ Extranet

1. Local Area Network (LAN)

A Local Area Network (LAN) connects a group of computers to share common communication media and computer resources, such as printers and file storage. The network covers small areas, such as single buildings or groups of buildings in close proximity connected by cables: twisted-pair, coaxial or fiber optic. In addition to cables, wireless technologies are increasingly being used to connect computers instead of physical media. A LAN can range from a simple network with a small number of computers to a hybrid network connecting many computers. A LAN is also capable of transmitting data faster than data being transmitted over a phone. The following Figures

(2.1 to 2.5) show the typical topologies for connecting LAN. Network topology is a physical and logical layout of computers on a network.

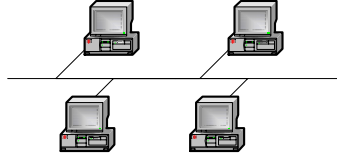

Figure 2.1: Bus topology connecting each computer to a single wire.

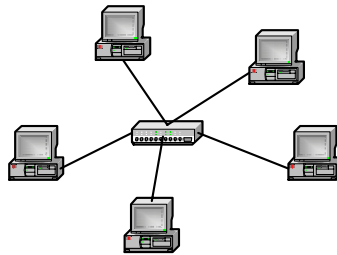

Figure 2.2: Star topology connecting all to computers to hub.

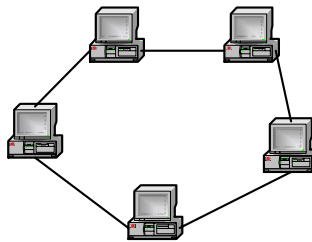

Figure 2.3: Ring topology connecting computers in a closed loop shape.

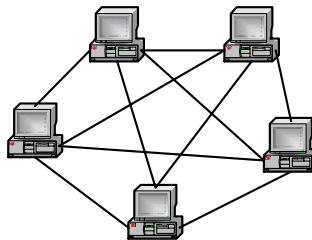

Figure 2.4: Mesh topology interconnecting computers between networks.

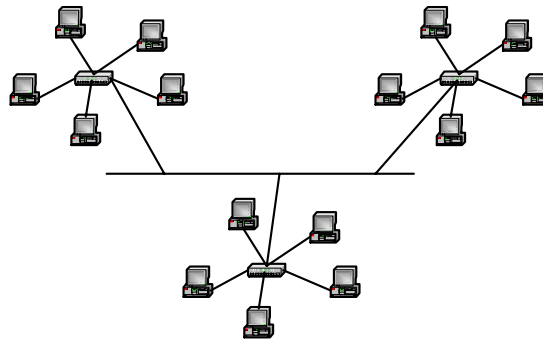

Figure 2.5: Tree (star-bus) topology connecting group of star topologies to a hub.

2. Wide Area Network (WAN)

A wide Area Network (WAN) is a communication network that connects sites across large geographic areas. As shown in Figure 2.6, a WAN joins more than LAN through a public network, such as the telephone system, a leased line or satellites to a large geographic area (pcwebopedia, 2002).

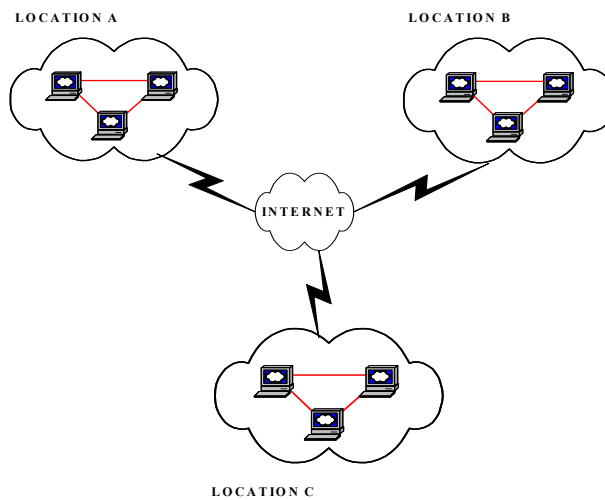

Figure 2.6: Wide Area Network (WAN) topology.

3. Wireless LAN and Wireless WAN

Wireless technologies can be used to connect buildings or units within a LAN or bases around the country where the terrain is difficult to establish a wired connection. This connection is also advantageous in increasing the ability of mobile troops to access information from the enterprise portal. Figure 2.7 and Figure 2.8 show typical wireless

LANs connecting computers in a small area and a wireless WAN connecting a large area respectively.

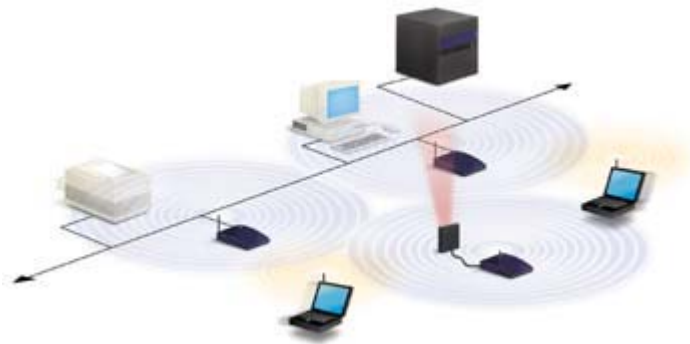

Figure 2.7: Wireless LAN (From Proxim Whitepaper [Online, 2002])

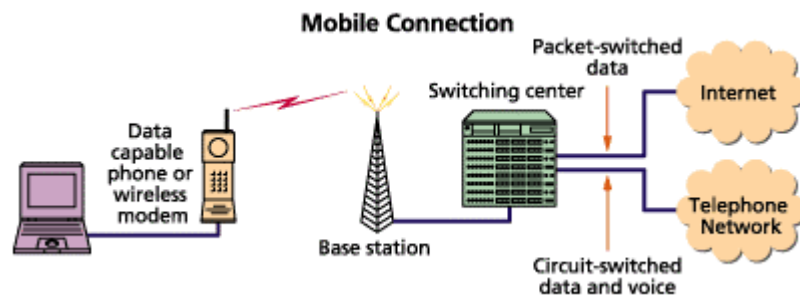

Figure 2.8: Wireless WAN (From: Rysavy, [Online, 2002])

4. Intranet/Extranet

An intranet is a computer network based on communications standard of Internet protocols, such as TCP/IP and HTTP. The Intranet is usually built behind firewalls to ensure that no unauthorized users can access the organization's information and other resources. Intranets facilitate sharing information within an organization through LAN connections. While the intranets are used to communicate within the organization, extranets are used to connect an organization with outside stakeholders.

The extranet function similarly to private networks within the Internet and it enables an organization to share information and applications with suppliers, customers and to conduct electronic commerce transactions safely, securely and inexpensively (Bort and Felix, 1997). For a large organization, such as the BDF, intranets serve as a foundation for the EIP.

F. MILITARY STRUCTURE VERSUS CORPORATE STRUCTURE

An EIP is a way for organizations to work more productively and expeditiously (Ferguson, 1999). Since implementations of EIP are prominent in commercial corporations, I propose that the same advantages that EIP gives to the commercial sectors will be evident in the context of government and military sectors. Therefore, this technology should be adopted in the BDF to facilitate the flow of information. An EIP is ideal in a situation when amassing and assimilating information across various units and the branches of the military. Incorporating wireless technology with an EIP can assist commanders of stationary and mobile troops to access the right information at the right time. Figure 2.9 and Figure 2.10 show the generic structural relation between corporate and military organizations with a three-level structure including each organization's basic functions.

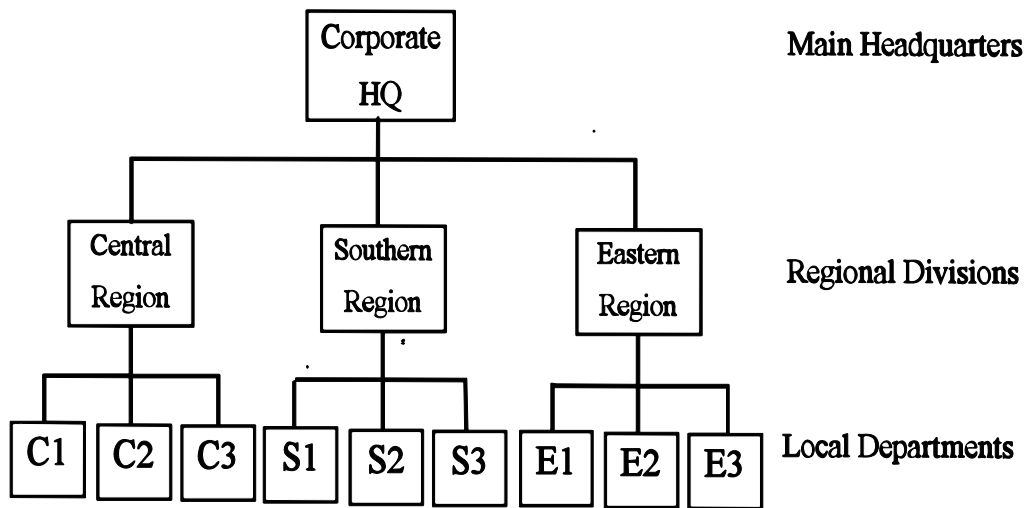

Figure 2.9: Corporate structure (From: Ince et al, 1997)

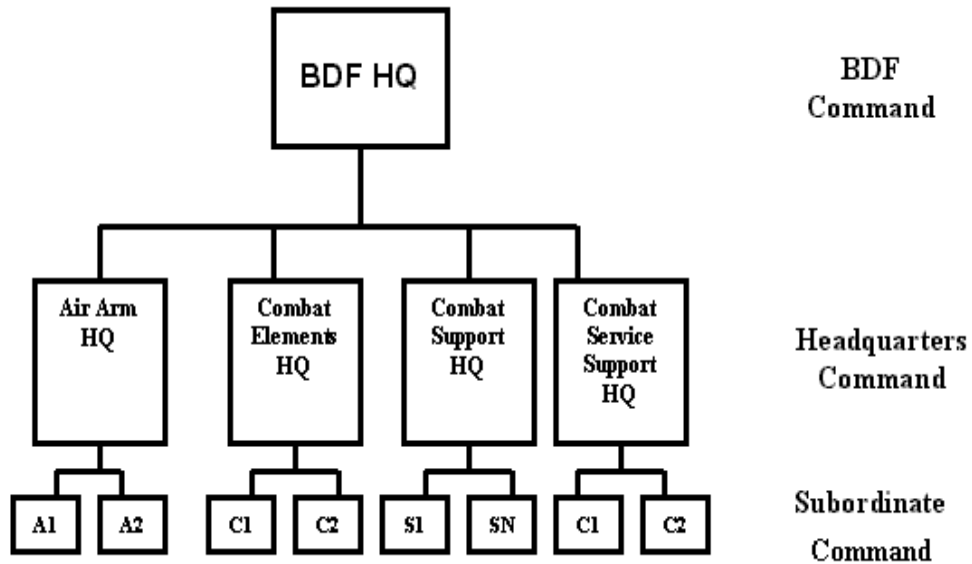

Figure 2.10: Military Organizational Structure (After: Ince et al, 1997)

The basic functions of an information system and its technical infrastructure in a military setting are the same as those in a commercial sector (Ince et al, 1997). An EIP provides collaboration of

- Business Executives
- Sales
- Marketing
- Production
- Logistics
- Administration
- Personnel
- Service and Support
- Projects (Ince et al, 1997).

In the military structure, each level contains staff level divisions of personnel, Intelligence, operations, logistics, plans and policies, communication and information systems. These divisions are responsible for the following activities:

- Command and Control
- Communications and Information System
- Exercise
- Logistics Planning and Execution
- Personnel
- Budget and Finance (Ince et al, 1997)

THIS PAGE INTENTIONALLY LEFT BLANK

III. THE BUSINESS CASE FOR THE BOTSWANA DEFENCE FORCE ENTERPRISE INFORMATION PORTAL (BDF-EIP)

There are many preliminary steps to building an effective enterprise portal that do little with portal itself. These involve a thorough familiarization with the business processes and procedures forming the circulatory system of the organization (Bella, 2001). In defining a business case for the BDF-EIP, this thesis will adopt the four-phases approach methodology proposed by Cassidy (1998) for building and implementing an information system. Each phase is presented and summarized in detail in the following order as shown Figure 3.1

- Phase one: Conceptual Business Level
- Phase two: Detailed Business Analysis
- Phase three: Conceptual Information System Plan and Vision
- Phase four: Planning Options Analysis and Action Plan

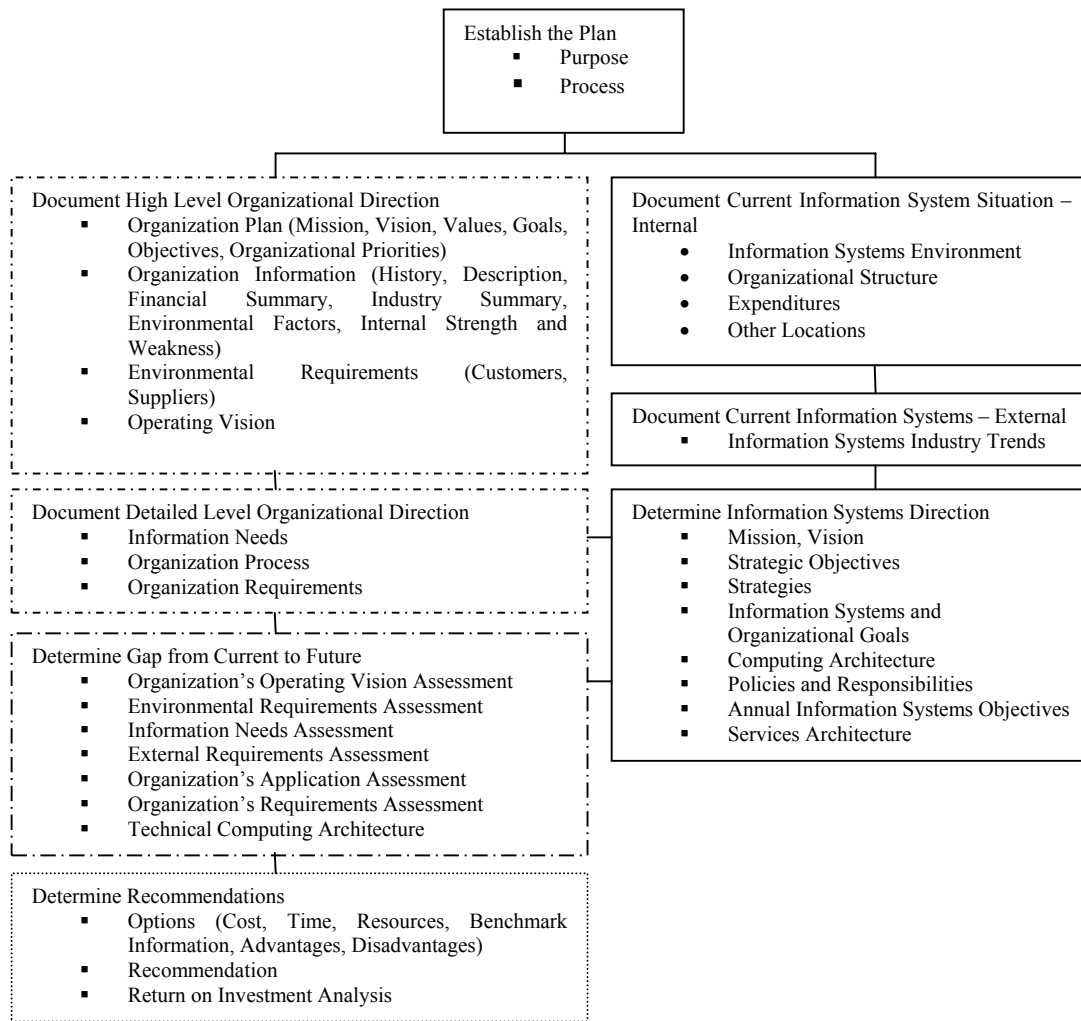

Figure 3.1: Business Case Contents (After; Cassidy, 1998)

A. PHASE 1: CONCEPTUAL BUSINESS LEVEL

This phase starts by understanding the organization at a conceptual business level and establishing its purpose, process and the scope of the information system. It is in this phase that detailed the organization’s business directions are covered and documented (Cassidy, 1998).

1. History and Composition of the BDF

The BDF was formed in 1977 to repel any spill over incursions from neighboring countries. The forces constituted a small number of personnel and limited resources in carrying out its mission. Ever since 1977, the BDF has grown in size and expanding its missions to protect the sovereignty of Botswana and to support national and international operations. Today, the BDF is comprised of six major bases, several small and temporary

bases around the country. In each major base, there are units and branches from the following military components.

Botswana Defence Force Headquarters (BDF-HQ)

Combat Elements

Combat Support

Combat Support Services

Air Arm

a. BDF-HQ

The BDF-HQ is the central organ of all the services of the BDF. The BDF-HQ is comprised of all directorates, units, and branches that collaborate and share information on a daily basis. The commanders of the BDF disseminate and receive information for command and control from all units, bases and other military components. Therefore, a plan for collaborating and communicating within and between these services is crucial. Even though all individual components have their own personnel administration and finance units, these units are centralized at the BDF-HQ. Information flows upward from units and bases in the country to the subordinate command and ultimately to the BDF-HQ.

b. Combat Elements

In Combat Elements, two Infantry Brigades headquarters are located in the southern and the northern regions of Botswana. Each Brigade is responsible for the infantry battalions in the regions. For daily operations and administration, information is passed from the Battalion commander to the Brigade commanders in each region. Therefore, all information requires being readily accessible to the higher command in the BDF.

c. Combat Support

The Combat Support echelon consists of the Artillery Brigade HQ, the Air Defence Brigade HQ and the Armour Brigade HQ located on different bases within the country. The commanders of these headquarters have regimental units in various locations. The transactions and flow of information follows the patterns as described for the combat elements.

d. Combat Support Services

The Combat Support Services consists of logistics units including the Mechanical Engineering Regiment HQ (MER-HQ), the Force Ordinance Corps HQ (FOC-HQ), the Medical Corps HQ and the Corps of Armament Services HQ (CAS-HQ). In addition to their own daily administration, these units are responsible for the logistical supply of the entire BDF. For instance, the Force Ordinance Corps (FOC) is the main BDF uniform distributor, generating uniform requests and supply from other units. In this scenario, the FOC communicates and shares information with its branches, with other units and with outside suppliers and vendors. Besides accessing the flow of information within and across these logistics units, the commanders at the BDF-HQ need to access up-to-date information about the units activities. This requires 24 hours availability of information

e. Air Arm

The Air Arm HQ has units located on the bases around the country. These units consist of squadrons, administration and personnel units that need to collaborate on day-to-day operations. The Air Arm HQ is also responsible for coordinating and communicating with other services and the BDF-HQ.

2. The Plan

a Purpose

The purpose of the information systems in an organization is to add value (Cassidy, 1998). Therefore, the purpose of the BDF-EIP is to leverage the Internet and web-based technologies in order to facilitate dissemination of BDF information to units and bases in the country. In addition to disseminating information, an information system will provide a means of cross-unit collaboration. The BDF-EIP will create a web-based environment securely integrating and personalizing internal and external contents and applications into a scalable user interface for the communities of e-business users across the enterprise. Additionally, the BDF-EIP should provide a scalable infrastructure to seamlessly integrate disparate data sources and applications, and to present a unified view across configurable user interfaces (Sagemaker, 2001).

b. Process

The process includes a procedure for organizing and documenting work activities to produce a product or service (Laudon and Laudon, 1999). The process of building the BDF-EIP should be agreed upfront by both the system builders and the system owners.

c. Scope

Scope defines the boundaries of the project, that is, what part of the business is to be studied, analyzed, designed, constructed and implemented and ultimately improved (Whitten et al, 2001). The scope of the BDF-EIP project is to cover all the major bases in the country as well as interfacing with outside military organizations such as the government sector (under the ministry responsible for the BDF), suppliers and contractors. To provide better coverage, mobile units with wireless access to the BDF-EIP can enable access to the system from the remote, temporary bases and troops on operations around the country. Furthermore, the EIP can be built using an incremental component approach allowing the additional of other modules later when the time and budget permits.

3. Organizational Direction

a. Mission Statement

At the beginning, the portal solutions that are aimed at achieving the overall purpose for the EIP should be defined (Collins, 2001). A mission statement is a brief statement identifying the purpose and function that an EIP provides for the organization (Cassidy, 1998). In the case of the BDF, a typical mission statement for the BDF-EIP would be to facilitate the availability of timely, accurate and secure information needed for managing the day-to-day and strategic direction of the BDF in achieving its objectives. The BDF-EIP will offer an organized and maintained source of information about the personnel, operations, logistics, plans and policies and information systems (Ince et al, 1997) while managing network distribution centers under the control and supervision of the BDF.

b. Vision

A vision is a short statement of the direction the organization intends to follow in establishing its information system (Cassidy, 1998). Since an EIP does not necessarily need to be formulated at high commands in the military, information technology experts understanding the advantages of implementing an EIP and the trend of technology can formulate the EIP using the organization's vision as their path. A typical example of a vision for the BDF-EIP is enabling everyone to access information, participate in and share organizational information with all personnel at any unit and any base, given proper security clearance (Cassidy, 1998).

c. Values

The BDF-EIP is a military initiative to give users in the military personalized information access through a browser-based portal. The real values of the portal is its ability to create an environment that allows users to collaborate, perform tasks and obtain information from a single customizable source (Diamondcluster Inc, 2001). An EIP can also be used to improve and enhance the decision cycle by having direct access to the organization's knowledge and resources (Collins, 2001). The security aspects should be implemented to ensure the integrity and the confidentiality of the information. Guaranteeing the security data classifications by issuing access rights to relevant information categories and users is essential.

d. Goals

Some of the most important goals for the BDF-EIP are enhancing unit collaborations and providing information sharing capabilities in the BDF. Although these are hard to quantify, they are goals in term of intangible benefits provided by information technology systems.

e. Objectives

The principal objective for the BDF-EIP is to deliver a flexible information technology architecture that allows integration and support for the entire organization's information technology applications (Sagemaker, 2001).

f. Priorities

This aspect for the implementation of the BDF-EIP involves a critical analysis of priorities to be performed by the envisioned system. The BDF-EIP should be elaborative to build the modules that facilitate fast and reliable information exchange between and among the units of the BDF. This precedence prioritizes implementing application programs specific to functional areas of the users in all units considering the constraints imposed by time and financial limitations and technological capabilities (Ince et al, 1997).

4. Requirements Analysis

Requirement analysis, the main process, involves examining of procedures needed to assess the best practices of implementing the BDF-EIP. The successful building and deployment of BDF-EIP depends on factors, such as clearly understanding the information to be provided by the portal, looking internally and externally at the organizational process along with the information system in the organization (Cassidy, 2001). As suggested by Collins (2001), in order to start making requirements and determining the feasibility of implementing BDF-EIP, the BDF should evaluate the information technology environment and identify the most critical challenges in the organization.

Requirements for an EIP must be defined upfront and documented providing a guideline for the process from the beginning to the end. In building the BDF-EIP, as with any other information technology system, the process requires appreciating the information needs of all stakeholders: system owners, systems users, system designers, system builders, system analysts, IT vendors and consultants (Whitten et al, 2001). Some critical considerations included in the requirement analysis are

- The need for connectivity
- Environmental requirements
- External requirements

a. *The Need for Connectivity*

The challenge facing the BDF is to facilitate an easy flow of information and collaboration across distributed major bases and units around the country. The need is to connect units, bases and people with the information in the BDF. Another need is to aggregate information into a centralized location for accessing and sharing with the units and branches in the BDF. There is also a need for timely, accurate and secure information for the effective coordination and collaboration of all units in operations and the strategic decision-making process. This timely, accurate and secure information has to flow from a “bottom up” and “top down” direction for each unit to be relevant to the users.

b. *Environmental Requirements*

The basic assumptions for the BDF-EIP are that (1) it will meet all the requirements of its users, (2) it will have a distributed architecture corresponding to the geographically distributed users and (3) it will always be ready to serve its users under anticipated conditions, which could exist in peace, tension, crises and war conditions (Ince, 1997). These requirements entail examining (1) the state of the organization’s readiness to adopt the new technology, (2) the organizational culture, (3) the past performance and (4) the expected changes to be instated into the organization. Rapid changes of technology in the market and rapid changes of user requirements should be considered in building the BDF-EIP with environmental requirements being completed through discussion with the EIP project groups, system builders, system owners and consultants.

c. *External Requirements*

The external business requirements include those for the users, the BDF and the government. Such requirements can be typically recovered through surveys that provide valuable information or through interviews and discussions, especially with the units representatives. Some external requirements that can be envisioned in today’s environment are the following

- Provisional access to all information and applications that are essential to the organization’s success across one, secure,

personalized and scalable browser-based interface (Sagemaker, 2001)

- Improved communications that provide the ability to tailor sub-portals according to the user's or group of user's needs.
- Extended access beyond the organization for the customers, partners and suppliers (Hall, 2000).

5. Operating Vision

This step synthesizes the high-level of the organization direction into phase two: the detailed organization direction. This operating vision section should question related information obtained from a high-level categories, such the mission or vision statement (Cassidy, 1998). A typical operating vision is to provide users in the BDF with information from cross-functions and cross-locations into a centralized location. The combination of information from disparate sources into a single environment that is personalized, efficient and user-friendly contributes to productivity improvement; therefore, reducing the time spent searching for critical information from different units and bases. This combined information contributes to a smarter organizational decision-making through advanced data aggregation, search mechanisms, automated notification and web-based content publishing (iManage, Inc., 2001).

B. PHASE 2: DETAILED BUSINESS ANALYSIS

1. Information Needs

Information needs are critical measures that indicate the present state of the organization and the direction of the business (Cassidy, 1998). With the proliferation of information technology and the continuous decline in computer prices, it is imperative for the BDF to implement the EIP in its mainstream, thereby reducing the information-intensive paperwork in the BDF. However, an EIP is a complex system since it can be costly if some basic steps in implementing the plan are omitted.

2. Business Process

In developing the BDF-EIP, the business process develops a system that is easy to use with a graphical interface to accommodate users with less computer skills. The effective methods of accessing information should be through an interactive web page to

supplement paper-based modes of information sharing in the BDF. The contents of the EIP should be centralized to minimize administrative hassles and cost. The private contractors would manage major technical issues while some of the BDF personnel would be provided with basic technical support requirements.

3. Business Requirements

The detailed business requirements are determined through planning group meetings to determine the most cost effective means to provide sufficient levels of service and support to the BDF offering an effective means of disseminating information to all users stationed in bases around the country.

C. PHASE 3: CONCEPTUAL INFORMATION SYSTEM PLAN AND VISION

1. Current information System in the BDF – Internal

There is currently no infrastructure within the BDF to support EIP initiatives. The information systems and associated functions be designed to be implemented from the “group up” by constructing the fundamental building blocks for EIP – LAN/WAN and intranet/extranet. Presently the BDF is planning to build local area networks in each of its six major bases and a logistics management system. Installation of the basic infrastructure for the LAN will serve as a starting point for the BDF-EIP and will be a foundation for future projects and information technology systems. The advantage of building an EIP is its ability to be incorporated into existing projects.

The present information systems of the BDF consist chiefly of stand-alone computers, direct and uncoordinated Internet connections used mainly on an individual basis. Stand-alone computers include using desktops and notebooks without being connected to the network. Direct Internet connections are provided to individual offices directly from the Internet service provider (ISP). These connections do not provide a means for the organization’s electronic communications nor facilitate storage of its information resources for sharing capabilities. A Wang VS6000 system is used in a portion of the BDF-HQ for personnel management and unit administration. In addition, the Finance unit under the BDF-HQ has a LAN; however, it does not link with the finance units and branches at all bases. The Wang system and the finance LAN are not linked to optimize information exchange through a WAN to other units or off base

activities. Therefore, collaboration and information sharing is chiefly conducted by manual means.

2. Current Information System Situation – External

The development of the infrastructure to support BDF-EIP will utilize current commercial technologies and vendor packaged portal software. In this case, assessing the current information technologies outside the BDF is important. An evaluation of these technologies would help in aligning the BDF-EIP to match the current industry trends and keep pace with the rapid technological changes. In addition, “because specific technologies changes rapidly, it is best to limit an organization’s scope to relatively stable and proven technologies”(Goodyear et al, 2000). This step is critical in selecting hardware and software platform to avoid locking the enterprise portal hardware and software from a company that may be out of business in a few years.

3. Portal Computing Architecture for BDF-EIP

As stated under the portal definition, an EIP is a complex information system made up of several technologies. Hence, this section discusses the features that are required for planning an EIP. Computing architecture is paramount to portal development and deployment to support an EIP in the BDF. The notion of computing architecture requires assessing the networking infrastructure, hardware and software. This assessment ascertains that computing architecture will conform to openness, interoperable and scalable standards.

a. Openness

Openness is derived from the Open System Interconnect (OSI) international reference model. It is designed to “enables a computer connected to a network to communicate with any other computer on the same network or different network regardless of the manufacturer, by establishing communication rules that permit the exchange of information between dissimilar systems” (Laudon and Laudon, 1999). The advantage offered by the openness feature is the ability to interface with products from multiple vendors that will avoid vendor “lock-in”.

b. Interoperability

Interoperability allows the portal computing architecture to interface with other systems in the organization.

c. Scalability

Scalability provides the ability for hardware and software to grow as the organizational needs grow and the technology changes without jeopardizing system requirements.

In addition, paying particular attention to openness, interoperability and scalability as a pivotal point for portal computing directly accounts for a system's obsolescence since today's technology is tomorrow's legacy system. The mechanisms that minimize system's obsolescence are incremental and rollout implementation of the BDF-EIP. The incremental approach permits hardware, software and other portal infrastructures to be distributed overtime keeping pace with the development and deployment of portal services. Conversely, rollout provides a measure of flexibility in implementing functionality and connections between portal services and data sources (Collins, 2001).

4. Service Architecture

This aspect in portal development address non-technical factors important to successful implementation of EIP. The service architecture is a blueprint that specifies which information processes and what kind of people are needed to support organization systems and computing architectures (Cassidy, 1998). Equally important to technology are people directly or indirectly involved in the building of an EIP. Without considering, the roles and responsibilities, including the skill sets, expertise and expectation upfront, disastrous effects can occur on the development of a portal in the BDF. A further point of view on people is discussed under the change management chapter.

5. Policies and Responsibilities

Documenting policies and responsibilities must be an integral part of an EIP development from the beginning. This documentation should include critical elements stating system resources procurements, training of portal administrators and users, maintenance and security policies. More emphasis is placed on the security of the portal system, both on the physical location and on the access to the system configuration. A statement of security policies can include that only authorized people have access to the EIP utilizing user identification through login identifications and passwords. These include policies and procedures that prevent unauthorized access, alteration, theft or physical damage to information systems (Laudon and Laudon, 1999).

Setting a time for periodic hardware and software upgrades with guarantee duration (such as 12 months, etc.) is essential. This includes establishing a schedule of future maintenance and system upgrades and guidelines maintaining licensing policies, such the anti-virus license or per user license. As supported by Cassidy (1998), formulating guidelines, policies and responsibilities permit the business to operate while not jeopardizing the large picture by conflicting with other organizational objectives.

In addition to documenting technical aspects for an EIP, articulating any concerns of an ethical, social and political nature pertaining to accountability and the use of the system are strongly advisable (Laudon and Laudon, 1999). Documentation of these roles and regulations are designed to control proper usage and misuse of the EIP.

D. PHASE 4: OPTION ANALYSIS AND ACTION PLAN

Option analysis and action plan are the final phase of an assessment for implementing an EIP in the BDF comprising reevaluation of the previous phases. In order to effectively develop and deploy the portal system, the main points discussed in this section are the analysis of the gap between the current and future state, option analysis and system recommendations (Cassidy, 1998). Usually, gap analysis determines if there is a modification or an upgrade of the existing system. In terms of the BDF, the initiatives of portal development would not evolve modification nor upgrade to an existing system because there is no existing structure or capability upon which to build – on an EIP. Therefore, gap analysis in this context entails reviewing the present ways in which

communications and the flow of information is handled in the BDF in addition to the desired future operations after implementing an EIP.

When analyzing the building of the BDF-EIP, I envision the necessity of three main options: (1) in-house development, (2) buying and (3) outsourcing. All of these options are evaluated based on three fundamental factors (costs, time and risk analysis).

1. In-house Building

The BDF should determine if it would entirely design and implement the BDF-EIP. The adoption of this option depends on whether the skills and expertise in the BDF can handle both the technical requirements and organizational requirement for the BDF-EIP.

Advantage of In-house Building

- In-house building offers the organization a full control of information assets.

Disadvantage of In-house Building

- There is high cost associated with in-house building that involves the acquisition of skilled employees.

2. Buying

Buying processes involves the use of commercial off-the-shelf software (COTS) in implementing the information system.

Advantage of Buying

- Using COTS eliminates the need for internally developing of software and programs thus reducing cost and time to develop and deploy the system.

Disadvantage of Buying

- Extensive customization of COTS may raise development costs and maintenance cost.

3. Outsourcing

Outsourcing is the practice in which an organization contracts with an outside vendor to assume responsibility for one or more information technology functions and services. The ownership of information assets including technology and employees in this practice are conveyed to the outsourcer (Whitten et al, 2001). Outsourcing is ideal when there is a lack of technical expertise within the organization and when the cost of building and maintaining information assets is more expensive than outsourcing the system to the second party.

Advantages of Outsourcing

- Produces cross-pollination of expertise from vendors to the organization's internal employees.
- Transfers information assets to vendors whose core competency is information technology that can free members of the organization to concentrate on the organization's main business procedures.
- Minimizes cost and produces a system even when internal resources are limited or there is lack of internally trained personnel to develop the system (Laudon and Laudon, 1999).

Disadvantages of Outsourcing

- Causes a loss of ownership of organizational information resources.
- Results in dependency on specific vendors.
- Presents a security risk to classified organizational information.

4. Risk Analysis

A risk analysis must be assessed for cost, schedule and performance of the BDF-EIP. Risk assessment determines the probability of the occurrence of the problem and the impact of damage if an event occurs (Laudon and Laudon, 1999). This includes detailed documentation of a plan on how to mitigate risks to avoid portal failure.

5. Design and Architecture

Figure 3.2 is a generic design of the BDF-EIP connecting major bases and the mobile units.

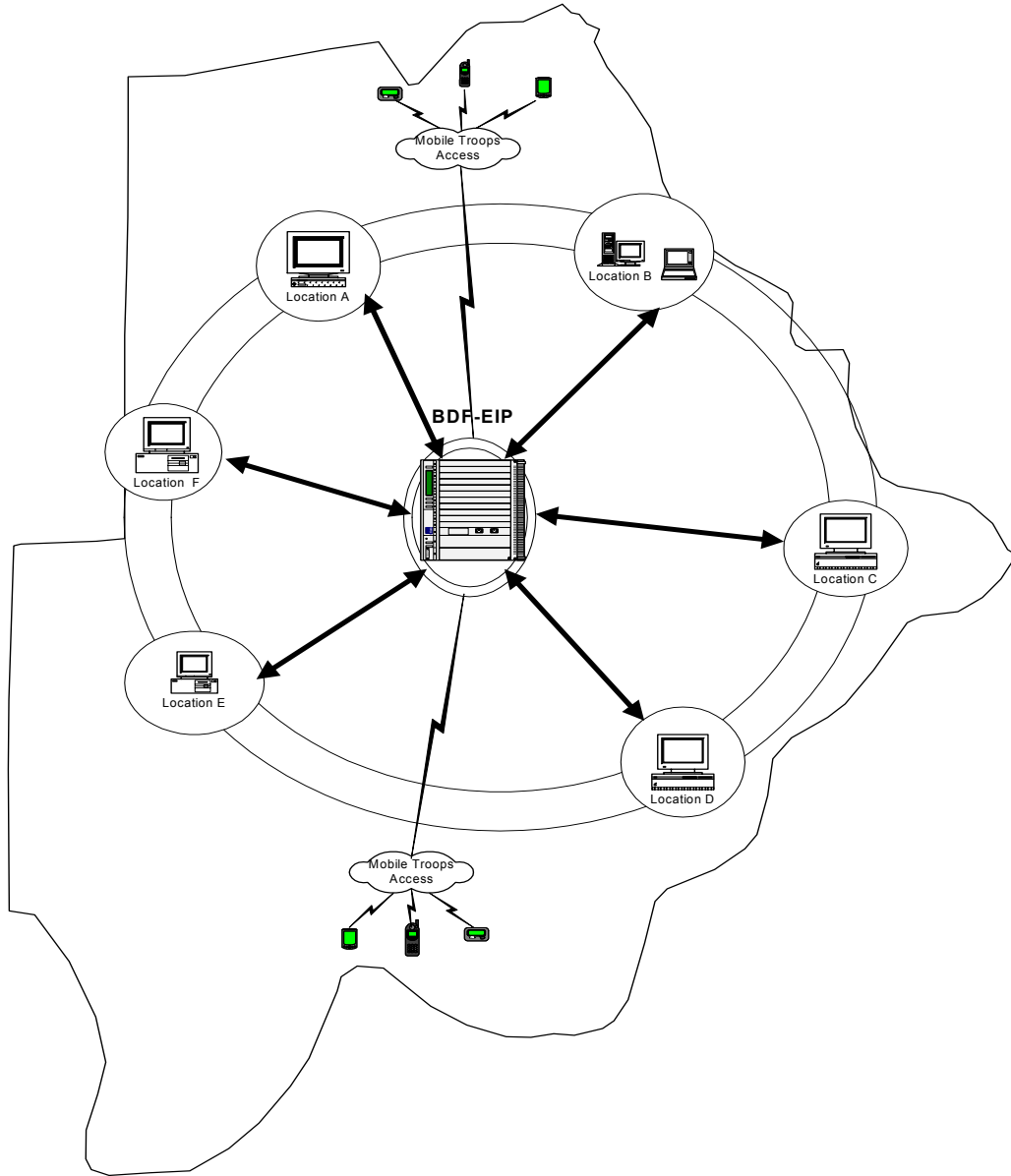

Figure 3.2: A BDF-EIP covering all Major Bases.

IV. CHANGE MANAGEMENT PROCESS

A. INTRODUCTION

One of the most important things to know about building a new system is that the process is one kind of planned organizational change. The system builders must understand how a system will affect the organization as a whole, focusing particularly on organizational conflict and change in the locus of decision making...The systems can be technical successes but organizational failures because of failure in the social and political process of building the system (Laudon and Laudon, 1999).

The purpose of this chapter is to explore some organizational challenges that can impact the BDF positively or negatively due to an introduction of new technology – the implementation of the proposed BDF-EIP. Introduction of an EIP in an organization, like any form of new technology, cannot be achieved without changes in the entire organization. Technology enables change; hence, it is important to assess the organizational readiness in adopting enterprise portal technologies. Furthermore, the biggest barriers to successful enterprise portals are not technological, but are organizational and human because the portal bridges organizational silhouettes and empowers all workers at all levels for decision-making (Agassi, 1999), thus complicating change phenomena further. Therefore, change and change management are the central focus in this chapter. According to Kanter (1999), “it is not enough for an organization to simply ‘get networked’ in this high-tech world, but it needs to be more fluid, inclusive and responsive”.

B. CHANGE

Changes in any organization are inescapable and always disruptive, even a positive change can cause adjustment problems (Conner, 1994). The proliferation of information technology and computers has compelled organizations to change the ways that organizations conduct business. This has rendered traditional methods of communication obsolete. Change is critical if an organization is to avoid stagnation as the pace of change has increased and is likely to increase further due to the speed of technological development (Rye, 2001). As Drucker (1999) stated that,

In a period of upheaval, such as the one we are living in, change is the norm, it is painful and risky, above all, it requires a great deal of very hard work. But unless organization sees that its task is to lead change, that organization - whether business, a university, or a hospital will not survive.

From the BDF's perspective, explaining change through concepts of change management processes and change agents are expected to enlighten the commanders and subordinates about the significance of technological advancement in the BDF, therefore involving people, shortening the learning curve and reducing the degree of resistance.

C. TYPES OF CHANGE

There are several ways to can be instigate change in organizations facilitating a smooth adoption and 'buying -in' from the users. Using this framework, I will examine various methods of change based on the following three types as defined by Anderson (2001).

1. Developmental (Incremental) Change

This form of change represents the improvement of existing skills, methods, procedures and performance standards that do not meet current or future needs of the organization. It requires enhancing the current state rather than radically changing from the old state to a new one. Additionally, this type of change takes into account that people are capable of improving when given good reasons for change, resources and motivation (Anderson, 2001). A developmental change is among the most common type of change that is on going in many organizations as part of improving quality or adjustments, such as simple growth or the adoption of a new technological process (Sadler, 2001). In most cases, this type of change is usually the result of a rational analysis, planning process with a desired goal and specific steps for reaching it. Usually limited in scope, developmental change is often reversible if it does not work succeed. An organization can return to its former methods. Developmental change is an extension of the past, that is, it does not disrupt the past patterns (Quinn, 1996).

2. Transitional Change

This type of change begins by recognizing that a gap exists between the present and desired state and a portion of the operation needs to be changed to better serve current and future demands. A typical example of the transitional change in an organization is the introduction of an information technology system that does not require major changes of individual behavior (Anderson, 2001).

3. Transformational Change

Transformational change profoundly involves radical shifts from one state to another. It is so significant that it requires a shift of culture, behavior or mindset to implement it successfully (Anderson, 2001). The purpose is to transform the organization in terms of all characteristic features and to achieve a step change in the level of performance. This degree of change cannot be achieved without significant changes in the underlying beliefs, values and established patterns of behavior of the organization (Sadler, 2001,). Figure 4.1 illustrates the combination matrix of these three types of changes.

Type	Degree of pain Felt	Primary Motivation	Degree of Threat to Survive	Gap Between Environmental Needs & Operations	Clarity of Outcome	Impact on Mindset	Focus of Change	Orientation	Level of Personal Development Required	How Change Occurs
Developmental Change	1	Improvement	1	1	4 It is prescribed against a standard	1 Little if any	Improvement of skills, knowledge, practice, and performance	To do better in a certain area: project-oriented	1	1 Through training, skill development, communications, process improvement
Transitional Change	3	Fix Problem	2	2	4 It is designed against criteria	1 Little if any	Redesign of strategy, structures, systems, processes, technology, work, behavior, and mindset (Not culture)	Project-oriented. Largely focused on structure, technology, and work practices	2	2 Controlled process, support structure, timeline
Transformational change	3-4	Survival: Change or Die; Breakthrough needed to pursue new opportunities	1-4	3-4	1 It is not initially known; it emerges or is created through trial and error and continuous course of correction	2-3 Forced to shift: Old mindset and/or business paradigm must change	Overhaul of strategy, structures, systems, processes, technology, work, culture, behavior, and mindset	Process-oriented requires shift in mindset, behavior and culture	3-4	3-4 Conscious process design and implementation, emergent process

Rating Scale: 1 is Low, 4 is high

Figure 4.1: Matrix of the Three Types of Organizational Change (After: Anderson, 2001)

D. CHANGE STRATEGIES

In order to implement a change of any form and help define a common thread through which members can understand the reason for changes, a combination of the following strategies as described by Jacobs (2001) should be considered:

1. Directive/Top-Down Strategies

This strategy involves a hierarchical top-down direction of implementing a change. An organization's leadership team decides and explains which changes are to be made through group meetings, task force reports and executive memos. To a lesser extent, the team can also explain why change has to be made.

Advantage

This approach is good if there is urgency in implementing a change and if the change is for short-term results.

Disadvantage

The desired changes communicated through this approach are rarely clear to everyone, even those open to change. The approach is likely to suffer from lack of commitment and collaboration instrumental for an effective implementation. Furthermore, putting change into practices is difficult because people lack personal ownership for making changes (Jacobs, 1997).

2. Bottom-up Strategies

This strategy provides a platform for people at a lower level to participate in a decision-making process.

Advantage

This strategy produces satisfying result for most people involved because of the feeling of ownership of change and high level of user commitment.

Disadvantage

Usually, the gains for one team are often at the expense of another resulting in long-term problems. A lack of overall strategic direction is evident for organizational-wide coordination between internally focused teams. Therefore, success is

limited only to good solutions for problems existing exclusively within separate functions, areas or levels (Jacobs, 1997).

3. Cross Section (Participative) Strategies

Cross Section involves the participation of representatives from cross-sections of the actual personnel ultimately affected by proposed changes. People from across the organization participate in helping to decide which changes are necessary and how to implement them. Groups of people involved are coordinated through task forces and subcommittees (Jacobs, 1997).

Advantage

There is a cross-pollination of ideas, understanding and deep commitment to change (Jacobs, 1997). Those individuals involved in this organization-wide process feel ownership of the change process.

Disadvantage

Reaching a consensus of change requires a great deal of time. In addition, Jacobs (1997) attests that, in this strategy many people throughout the entire organization are often not meaningfully involved or do not understand the changes and why they are needed.

E. CHANGE MANAGEMENT

Change management is a process that extends beyond information technology projects and it is two-dimensional. First, change management can be viewed as a “management system for planning, coordinating and reporting system changes that have the potential to impact negatively service provided by the production operation department” (Frenzel, 1992). According to Frenzel, (1992), the objective of this change management process is to ensure that changes are implemented with minimum or acceptable levels of risks and that services are not jeopardized by change activities. This particular change management handles the technical process of building, designing and implementing an information system by documenting any change that includes modifications to hardware, software and the network infrastructure. The process of

change management process can originate from human processes, manual procedures and the environment.

The second dimension of change management depicts a larger picture of the whole system involving “the ability to help people in an organization to assimilate, accept and take advantages of new technology” (Goodyear et al, 2000). For example, an introduction of a new technology in the BDF for enhancing the units and bases collaboration is an organizational wide change that requires the latter dimension. McNamara (1999) refers to this dimension of change management as organizational transformation t designating a fundamental and radical reorientation in the way the organization operates.

In the change management process, a change in whatever form interfaces with three organizational components constituting a corporate culture. These components are shown in Figure 4.1

- The historical and political evolution of the organization
- The management and organization
- The people who work for the organization (Rye, 2001)



Figure 4.2:Components of Corporate Culture (From: Rye, 2001)

1. Organizational History and Politics

The historical and political evolution of an organization has significant bearing on its acceptance of change. These conditions are captured through the analysis of where the origins of the organization lies, its values and the image it wants to promote and the origins of individuals within the organization. In addition, through the establishment of traditions and norms in which leadership and subordinates alike have become accustomed, the effects of change on the balance of power, as measured in terms of current owners of the resources and expertise and the long-standing policies and rights, are both written and unwritten (Rye, 2001). An evaluation of the BDF's historical, political and cultural evolution will have a role in its acceptance of change.

a. Culture

The culture of an organization is important to the success of any change initiatives. If the beliefs, behaviors and assumptions of an organization are in conflict with the goals of a change initiative, the rhetoric of change can be disseminated, but its full intent will not be realized (Conner, 1994). There are many ways in which bureaucratic culture proves to be a barrier to change, including multiple layers of hierarchy, a tradition of top-down change, short-term thinking, lack of top-management support for change, limited rewards, lack of vision and a emphasizes on the status quo (Quinn, 1996). Any planned change pertinent to BDF-EIP should include an appreciation for potential cultural impacts. In order to understand an organization, a person should first identify the organization's culture. Many definitions of culture focus on sharing and emphasizing commonalities in people (group norms, root metaphors, espoused values, etc.). However, culture adds two important elements to the concept of sharing: (1) group structural stability and (2) integration of the elements into a larger paradigm.

Additionally, culture is largely based on a group's shared learning-group history and shared experiences. While managers may live within a culture, leaders create and change culture. Therefore, leaders must understand an organization's cultures if they are to lead and introduce change (Schein, 1992). Schein (1992) defines culture as,

A pattern of shared basic assumptions that the group learned as it solved its problems of external adaptation and internal integration, that has

worked well enough to be considered valid, and therefore, to be taught to new members as the correct way to perceive, think, and feel in relation to these problems.

This definition has three important elements: (1) shared assumptions learned through problem solving, (2) the assumptions worked well enough and (3) teaching of the accepted, workable assumptions to new people as the correct way to “be.” This definition implies that a culture is forever growing and changing as new external and internal problems arise. While this is true, a leader must be aware of the culture before a change is made. Otherwise the leader may attempt to make a change that the organization’s members do not feel is needed to externally adapt or internally integrate. Therefore, the military culture of the BDF is instrumental in proposing any new technology in order to eliminate conflict with the current status quo.

Schein (1992) also discusses three levels of culture: artifacts, espoused values and basic underlying assumptions. Artifacts are the visible organizational structures and processes. While these are easy to see, they are difficult to decipher. Espoused values are the organization’s strategies, goals, philosophies, and espoused justifications. Underlying assumptions are the unconscious, taken-for-granted beliefs, perceptions, thoughts, and feelings. These are the source of values, actions and the basis for the culture. All three elements are interactive as illustrated in figure 4.2:

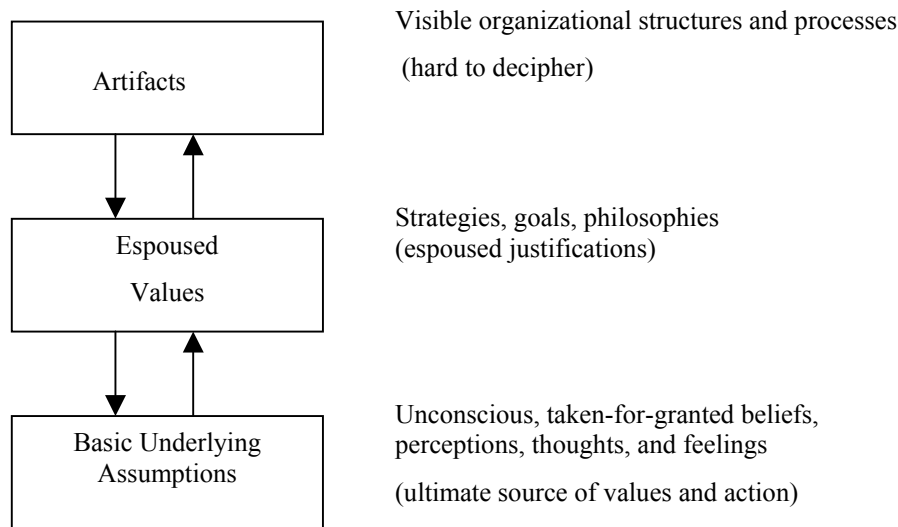

Figure 4.3: Levels of Culture (From: Schein, 1992)

Since culture is born from the learning process, culture is a human attempt to deal with uncertainty. Therefore, culture provides stability, meaning, and predictability in the present because of effective solutions to problems in the past. Culture is internally integrated through various processes, including: (1) creation of a shared language and its concepts, (2) definition of group boundaries and rules for inclusion/exclusion, (3) distribution of power and status, (4) definition and allocation of rewards and punishments, and (5) explanation of the unexplainable—ideology and religion. Ideology can be defined as overarching values that act as a prescription for action, especially in circumstances that are difficult to manage or explain. The shared assumptions that the organization has developed over time serve a stabilizing and meaning-providing function (Schein, 1992). Schein (1992) discusses three sources of cultures: (1) beliefs, values and assumptions of the organization’s founders, (2) learning experiences of group members as the organization evolves, and (3) new beliefs, values, and assumptions brought in by new members and leaders. Additionally, he discusses the differences between “young” and “mature” cultures. A young culture is one where the founders of the organization are still in charge or highly visible. In a mature culture, life is taken more for granted—it is established. Within any organization, there will be multiple cultures, and these cultures may be young or mature.

2. Management and Organization

Change will affect the roles of management and the structure of the organization. Therefore, assessing the proportion of workforce able to cope with change and to make a required transition is important (Rye, 2001). Due to information technology, some of the likely effects of change are as follows:

- Boundaries between jobs, division and department become blurred as the management roles shift from autocrat to that of facilitator,
- Management takes a more strategic stance fostering progress through innovation and recognition of contribution to achieve organization objectives (Rye, 2001)

3. People

When introducing a change the leaders must first find a connection between the organization, the workers and the change initiatives being introduced. This connection is achieved by fostering resilience among individuals in the organization (Conner, 1994). Conner (1994) stated that for the organizational readiness to change, leaders must understand the patterns representing people's behaviors, beliefs, feelings and basic assumptions that everyone experience during major change. All of all these factors require leaders or managers to consider carefully how they can convince people who are affected to accept them (Kirkpatrick, 2001). To avoid the "build it, they will come" syndrome, the proposed systems should be communicated to all the people who will experience a change. Since technology should involve people, change can be effective if it involves people. Change should be integrated in the entire building process of the enterprise information portal. The involvement of users augments the system in satisfying the expectations of users and management as well as in facilitating a high level of acceptance (Goodyear et al, 2000). User involvement in the systems development has the following benefits:

- Facilitates acceptance at an early stage
- Increases commitment to change throughout the organization
- Decreases resistance to change

4. Resistance to Change

Resistance to any information technology should not be viewed as impedance but a way to help successful planning and implementation of modern technology. Conner (1994) advocates, “Resistance is a natural component of the change process”. He further emphasizes that “people actively resist major transition when they feel their well-being is in jeopardy or if they do not know how to accomplish the change”. Senge (1990) states,

Resistance to change is neither capricious nor mysterious. It almost always arises from threats to traditional norms and ways of doing things. Often these norms are woven into fabric of established power relationships. The norm is entrenched because the distribution of authority and control is entrenched. Rather than pushing harder to overcome resistance to change, artful leaders discern the source of resistance. They focus directly on the implicit norms and power relationships within which the norms is embedded.

Another reason for resistance to change is that people may feel that there is no need for the change (Kirkpatrick, 2001) The best approaches to address resistances are through increased and sustained communications and education. For example, the leader should meet with all managers and staff to explain reasons for the change of acquiring new systems in the entire organization and the process of carrying out the change (McNamara, 1999). In the case of the BDF, the commanders must first be committed to EIP as a vital solution and should actively explain to the rest of the personnel how this system would benefit them in performing their daily work. The purpose of encouraging the personnel is to increase their efficiency, effectiveness and overall productivity. There are many reasons why employees may react negatively to change. One of these is the personal loss of the following factors: security, money, pride and satisfaction’, friends and important contacts, freedom, proprietorship behavior, responsibility, authority, status and working conditions (Kirkpatrick, 2001).

F. CHANGE AGENT

The possible way to sell the portal idea to the rest of the personnel in the BDF is through change agents. Change agents are those who communicate the potential need for change and communicate what should be done, as well as how it should be done (McNamara, 1999). Their role is to ensure that the current situation, structures and working methods – the ‘platform’ for changes are understood through consultation with those involved (Rye, 2001). The information enterprise-system development team can also be a change agent. This is the team that must convince its users that the system will motivate them to be more effective in performing their jobs and in achieving the organization’s objectives (Goodyear et al, 2000). The role of change agents is to involve the users and manage the users’ involvement.

G. CHAMPION

In order for the proposed BDF-EIP to be successful, a champion must be identified and engaged. The commander in the BDF could be the project champion. A champion is a key project sponsor, someone who plays a leadership role in ensuring the success of the system by demonstrating the organization’s overall commitment to system development. A champion also ensures that users and information systems developers are committed to EIP development. A champion is typically an executive from the users’ organization that benefits from the system and pays for its development (Goodyear et al, 2000). A champion must be from a line command but not necessarily a technical specialist. In particular, the highest line commander, such as the commander-in-chief, is an ideal champion (Haga, 2002). An example of a military commander acting as a champion for an information technology system was Admiral Clemons’ backing the implementation of IT-21 in the U.S. Navy (Haga, 2002).

H. PLANNING CHANGE/IMPLEMENTATION

Given an overview of change and change management models, this section provides guidelines that could help in implementing BDF-EIP in the BDF. This is a systematic approach to manage change as proposed by Kirkpatrick (2001). See Figure 4.3 showing a seven-step process for a successful implementation of change:

1. Determining the Need or Desire for a Change

The first critical step is determining the need for desired change. In the case of the BDF, lack of cross-units collaboration and flow of information are major reasons for the BDF to adopt an EIP. As mentioned by Kirkpatrick (2001), this step can be done in many ways, e.g. based on facts or feelings; top management can determine the need for change or, a manager, either personally or based on suggestion from the subordinates can decide the need for a change (Kirkpatrick, 2001). Change agents who assess present culture within the BDF and the expected culture after transformation should carry out this step. The idea is to introduce information technology systems with minimum resistance from the users, both the commanders and the subordinates.

2. Preparing Tentative Plans

This step should involve a combination of change strategies discussed in the previous sections to solicit ideas for tentative plans of change through brainstorming.

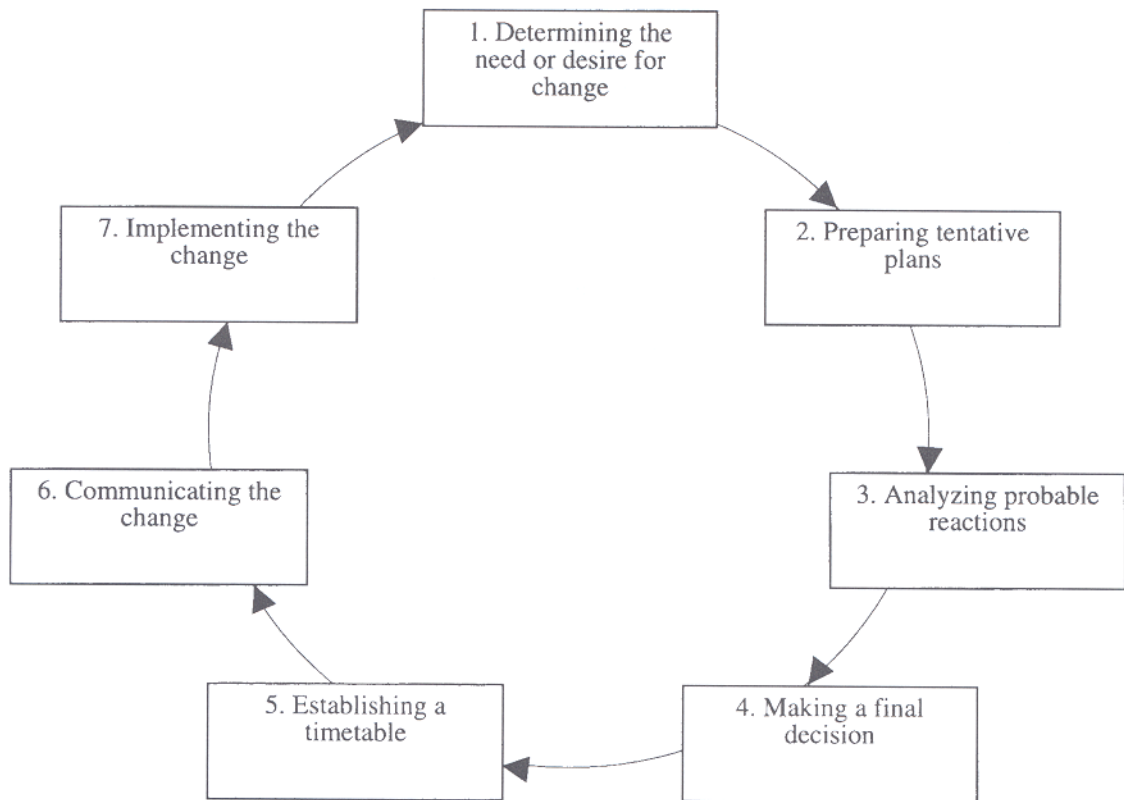

Figure 4.4: A Manager's Model for Change (From: Kirkpatrick, 2001)

3. Analyzing Probable Reactions

It is normal for people to react with shock, anxiety and confusion to change. Therefore, every proposed change will be met with three different types of reactions: (1) some people will resent and possibly resist the change if it is implemented, (2) some people will remain neutral and (3) others will accept and possibly welcome the change (Kirkpatrick, 2001). This will help measure the degree of success of the envisioned BDF-EIP.

4. Making a Final Decision

In making a final decision, two approaches can be used: first, the leader should consider all the data and decide based on inputs from the first through to the third step. This approach is quick and emphasizes the authority and the status of the manager. A high level of acceptance is also achieved if the people will benefit from the decision. Second, the leader should use group problem solving. This is advantageous in getting a high level of commitment for a decision by the subordinates because it is a participatory decision than a leader's decision (Kirkpatrick, 2001).

5. Establishing a Timetable

For a change to be implemented, it must have a definite timeline for implementation. According to Kirkpatrick (2001), either change can be coerced or it can be decided by participation.

The coercive approach is fast while the participative is slow and evolutionary. The disadvantage of coercive approach is that it can only be maintained as long as the leader has a position of power to make it stick. This approach often results in animosity, hostility and in some case, overt and covert behavior to undermine and overthrow the powers that be. The main advantage of participative style is that it tends to be long lasting. The speed at which change is introduced may be as important as change itself (Kirkpatrick, 2001).

6. Communicating the Change

Communication of the proposed change is vital in establishing an understanding and common ground of what is being achieved. "Although it is listed as step six, communication is a continuous process that begins from step one. It must have a two way

process – telling and selling the plan, as well as listening to reactions and suggestions” (Kirkpatrick, 2001).

7. Implementing the Change (BDF-EIP)

This is the action stage that involves the implementation of the proposed change and continuous monitoring and evaluation of the situation. Expectations are that after the BDF understands how an EIP can impact the overall picture of new BDF, the probability of acceptance of an EIP would increase.

V. CONCLUSION AND RECOMMENDATIONS

A. CONCLUSION

The continuing decrease of information technology prices, coupled with increasing computing power, makes it more viable to revolutionize organizational affairs. This study is a first time initiative to analyze the best technology suitable for the BDF. The thesis further addresses the nature of traditional modes of communication in the BDF. As the requirements for information technology grow, the development and deployment of a new information system will become important for improving collaboration and information flow in the BDF. An EIP is one of the appropriate technologies that the BDF should consider in alleviating problems in communications and information sharing among the units.

This thesis explored the feasibility of implementing a portal technology in the BDF to foster cross-unit collaboration. The overreaching idea was to establish an EIP strategy beyond a technological perspective including among other things an analysis of what an EIP is, how to implement an EIP and how to manage other organizational challenges, such as change management and change itself.

In addition, this thesis defined portal technology to conform to non-technological audiences identifying the characteristics critical to meet the dynamics and requirements of the BDF. An EIP is like any other information system since its successful implementation is based on addressing organizational challenges of introducing a change. Thus, the overarching principle objective of this research has been to investigate a technology that can potentially increase cross-unit collaboration in the BDF, thus, helping the commanders and the subordinate in making faster and better decision.

B. RECOMMENDATIONS

This thesis recommends the implementation of an EIP to the BDF as a communication tool to enhance its administrative capabilities and, most importantly, to improve its command and control. Unfortunately, many other relevant areas could not be covered in detail due to lack of resources, particularly those addressing the information technology posture of the BDF. Furthermore, the author did not delved into

organizational aspects that are critically important in explaining details of an EIP implementation in the BDF in order not to risk exposing information possibly deemed as classified. Besides these constraints, this thesis postulate the following recommendations:

- The BDF must develop and deploy an EIP to solve the problem of information flow within and among the units and bases in the country by following the theoretical groundwork covered in this thesis for a successful implementation.
- The information technology system's vision and strategy (in particular an Enterprise Information Portal) must be established as the integral part of the organizational strategies.
- The BDF must explore information technology to leverage its benefits and keep pace with technological development. In addition, the thesis serves as a benchmark to further research for information technology in the BDF.

LIST OF REFERENCES

1. Agassi S., 1999, Using an Enterprise Information Portal to Enhance Your ERP System [Online] Available <http://toptier.com>.
2. Anderson D., 2001, Beyond Change Management: Advanced Strategies for Today's Transformational Leaders, San Francisco, Jossey-Bass/pfeiffer.
3. Bella J., 2001, Corporate Portals: What They See is What They Get [Online] Available <http://itmanagement.earthweb.com.html>.
4. Bort J. and B. Flex, 1997, Building an Extranet: Connect Your Intranet with Vendors and Customers [Online] Available <http://www1.fatbrain.com.html>.
5. Cassidy A., 1998, A Practical Guide to Information Systems Strategic Planning, Washington DC, St. Lucie Press.
6. Collins H., 2001, Corporate Portals: Revolutionizing information Access to Increase Productivity and Drive the Bottom Line, AMACOM.
7. Conner D., 2001, Bouncing Back [Online] Available <http://www.odrinc.com/inter/new/delta.html>.
8. Davydov M., 2001, Corporate Portals and e-business Integration, McGraw-Hill,
9. DiamondCluster Inc, 2001, Enterprise Portals: Building Value Through Organizational Knowledge, Vol. 2, Number 2 [Online] Available <http://www.diamondcluster.com>.
10. Drucker P.F., 1999, Change Leaders, "The New Commandments of Change" [Online] Available <http://inc.com/incmagazine>.
11. Ferguson M., 1999, Building Enterprise information Portal [Online] Available <http://www.itworks.be/BuildingEnterpriseinformationPortals.html>.
12. Finkelstein C., 2000, Building Corporate Portals Using XML, New York, McGraw-Hill Professional.
13. Firestone J., DKMS Brief No. Ten: Benefits of Enterprise Information Portals and Corporate Goals [Online] Available <http://www.dkms.com/EIPBenefits.html> / November 2001.
14. Fitzgerald P., Tie it Together and Open it Up with Enterprise information Portals [Online] Available <http://www.intranetjournal.com/Articles.html>, April 2001.

15. Frenzel C.W, 1992, Management of information technology, Boston, Massachusetts, Boyd & Fraser.
16. Gannon T, 2000, A Business Solution: EIP [Online] Available <http://www.Dmreview.com>.
17. Goodyear M et al., 2000, Enterprise System Architectures: Building Client/Server and Web-based Systems, Boca Raton, Florida, CRC Press.
18. Haga, W., Personal Conversation, 2002
19. Hall C., 2000, Enterprise Information Portals: Hot Air or Hot Technology, Arlington, Massachusetts, Cutter Information Corp.
20. iManage Inc., 2001, Enterprise Portals: Powering Mission-Critical Applications [Online] Available <http://www.kmworld.com/publications/whitepapers/portals/imanage.htm>.
21. Ince N.A et al., 1997, Planning and Architectural Design of Modern Command and Control Communications and Information Systems: Military and Civilian Applications, Norwell, Massachusetts, Kluwer Academic Publishers.
22. Jacobs R.W., 1997, Real Time Strategic Change: how to Involve an Entire Organization in Fast and Far-Reaching Change, San Francisco, California, Berrett-Koehler Publishers.
23. Kanter R.M., 1999, Leader to Leader, “The Enduring Skills of Change Leaders” [Online] Available <http://www.pdf.org/leaderbooks/121/summer99/kanter.html>
24. Kirkpatrick D.L., 2001, Managing Change Effectively: Approaches, Methods and Case Examples, Woburn, MA, Butterworth-Heinemann.
25. Laudon K.C and J.P Laudon, 1999, Essentials of Management Information Systems, Upper Saddle River, New Jersey, Prentice Hall.
26. McCabe J.D, 1998, Practical Computer Network Analysis and Design, San Francisco, California, Kaufmann Publishers Inc.
27. McNamara C., 1999, Basic Context for Organizational Change [Online] Available <http://www.mapnp.org/library/mgmt/orgchange.htm>.
28. Pcwebopedia, 2002, Wide Area Network [Online] Available http://www.Pcwebopedia.com/TERM/w/wide_area_network_WAN.html.

29. Pfleeger, 1997, Security in Computing, Upper Saddle River, New Jersey, Prentice Hall.
30. Proxim, White Paper, What is a Wireless [Online] Available <http://www.proxim.com/learn/library/whitepapers>.
31. Quinn R.E., 1996, Deep change: Discovering the Leader, San Francisco, California, Jossey-Bass.
32. Rye C., 2001, Change Management, London, UK, Kogan Page.
33. Rysavy P., Wide area Network [Online] Available <http://www.networkcomputing.com/netdesign/wireless1.html>.
34. SageMaker, Inc. 2001, Whitepaper, The Benefits of an Enterprise Information Portal [Online] Available <http://www.itpapers.com>
35. Sadler P., 2001, The Seamless Organization: Building the Company of Tomorrow, London, UK, Kogan Page.
36. Schein E.H, 1992, Organizational Culture and Leadership, San Francisco, California, Jossey-Bass Inc.
37. Senge P., 1990, The Fifth Discipline: The Art & Practice of Learning Organization, New York, New York, Doubleday.
38. Whitten J.L. et al., 2001, Systems Analysis and Design Methods, New York, NY, McGraw-Hill Irwin.
39. VIADOR Inc. 2000 Whitepaper, VIADOR E-PORTAL – An Enterprise Information Portals Architecture [Online] Available <http://www.Itpapers.com/cgi/PsummaryIT>.

THIS PAGE INTENTIONALLY LEFT BLANK

INITIAL DISTRIBUTION LIST

1. Defense Technical Information Center
Ft. Belvoir, Virginia
2. Dudley Knox Library
Naval Postgraduate School
Monterey, California
3. The Commander, Botswana Defence Force
Private Bag X006
Gaborone, Botswana
4. The Director
Directorate of Information Management Systems
Botswana Defence Force
Private Bag X006
Gaborone, Botswana
5. Defense, Military and Air attaché
Embassy of the Republic of Botswana in Washington DC
1531 – 1533 New Hampshire Ave, NW
Washington DC 20036
6. William Haga, Code 36
Naval Postgraduate School
Monterey, CA 93940
7. John Osmundson, Code 39
Naval Postgraduate School
Monterey, CA 93940
8. Moemedi B. Ramorathudi
P O Box 760
Molepelole, Botswana