

UNCLASSIFIED

2-7-9

~~CONFIDENTIAL~~

TECHNICAL REPORT

**A USA
Library Section**

No. F-TR-2201-ND
GS-USAF-WRIGHT-PATTERSON
AIR FORCE BASE No. 85

C 837

BMW ROCKET-ENGINE DEVELOPMENT
(Project No. FP-190)

D. Singelmann and H. Mueller

~~CONFIDENTIAL~~



Release Date:
May 1948

DISTRIBUTION STATEMENT F:

Further dissemination only as directed by

May 48

or higher DoD authority.

20020306 059



**HEADQUARTERS AIR MATERIEL COMMAND
WRIGHT-PATTERSON AIR FORCE BASE,
DAYTON, OHIO 45433**

~~CONFIDENTIAL~~

UNCLASSIFIED

F-TR-2201-ND

UNCLASSIFIED

NOTE

When drawings, specifications, and other data prepared by the War Department are furnished to manufacturers and others for use in the manufacture or purchase of supplies, or for any other purpose, the Government assumes no responsibility nor obligation whatever; and the furnishing of said data by the War Department is not to be regarded by implication or otherwise, or in any manner licensing the holder, or conveying any rights or permission to manufacture, use, or sell any patented inventions that may in any way be related thereto.

The information furnished herewith is made available for study upon the understanding that the Government's proprietary interests in and relating thereto shall not be impaired. It is desired that the Patent & Royalties Section, Office of the Judge Advocate, Air Materiel Command, Wright Field, Dayton, Ohio, be promptly notified of any apparent conflict between the Government's proprietary interests and those of others.

Espionage Act

Notice: This document contains information affecting the national defense of the United States within the meaning the Espionage Act (U. S. C. 50:31, 32). The transmission of this document or the revelation of its contents in any manner to an unauthorized person is prohibited by law. (AR 380-5, paragraph 17 b.)

"The above Espionage Notice can be disregarded unless this document is plainly marked with a security classification as "Restricted," "Confidential," "Secret," or "Top Secret."

The U. S. Government is absolved from any litigation which may ensue from the contractor's infringing on the foreign patent rights which may be involved.

Reproduced From
Best Available Copy

UNCLASSIFIED

UNCLASSIFIED

TECHNICAL REPORT
REPORT NO. F-TR-2201-ND
GS-USAF WRIGHT-PATTERSON
AIR FORCE BASE NO. 85

HEADQUARTERS
AIR MATERIEL COMMAND
WRIGHT-PATTERSON AIR FORCE BASE
DAYTON, OHIO

BMW ROCKET-ENGINE DEVELOPMENT

by

D. Singelmann and H. Mueller

Propulsion Section, Technical Intelligence Division,
Intelligence Department
Project No. FP-190
Project Engineer: R. F. Gompertz

Confidential classification downgraded to
Restricted 16 March 1949 by authority of
Commanding General, AMC

By *Royal J. Sinclair Capt USAF.*
Date: 16 March 1948

Approved by:

W. R. Clingerman
W. R. Clingerman, Colonel, USAF
Chief, Technical Intelligence Division
Intelligence Department

For the Commanding General:

H. M. McCoy
H. M. McCoy, Colonel, USAF
Chief of Intelligence

PUBLISHED BY AIR DOCUMENTS DIVISION
INTELLIGENCE DEPARTMENT

UNCLASSIFIED

UNCLASSIFIED



BMW Rocket-Engine Development
(Project No. FP-190)

Dietrich Singelmann and Heinz Mueller

ABSTRACT

Developments in the rocket-engine design field to produce satisfactory operational units are difficult, slow and very expensive in time and money.

Several outstanding features of successful rocket engines developed by the German BMW Company (Bayrische Motoren Werke) from 1939 until the cessation of hostilities are described in this report.

The development and design of several special propellant control valves, operated by a solenoid-servo system, results of painstaking work in nitric-acid propellant feed pumps, sealing and cavitation problems, and in film cooling are shown in detail. A simple yet accurate device for measuring the ignition delay of self-reacting rocket propellant is briefly described.

Material presented is based exclusively on test reports and actual experience; theoretical calculations are held to a minimum.

INTRODUCTION

This report is a compilation of reports on several developments completed at the Bayrische Motoren Werke, Germany, during World War II.

UNCLASSIFIED



BIOGRAPHICAL NOTES

Mr. Dietrich Singelmann attended the Technical University of Breslau from 1923 to 1927, and received his Dipl. Ing. He was assistant to Professor Ehrhardt, University of Breslau, and to Professor Bernstein and Professor Martiny, University of Halle from 1928 to 1932.

From 1932 to 1933 he was associated with the Ilo-Werke at Pinneberg near Hamburg, designing small reciprocating engines; and from 1933 to 1938 he was associated with Siemens & Halske Werke (aircraft engines) designing aircraft engines and accessories. From 1938 to 1939 he was affiliated with the design branch of the research section of the Brandenburgische Motorenwerke, Spandau; and from 1939 in charge of the design branch of the Bayerische Motorenwerke, Spandau; later on in charge of the test and design branch of the rocket-engine manufacturing company, Zuehlsdorf East. Since 1943, he had been general manager of the Zuehlsdorf Plant.

Mr. Heinz Mueller attended the Technical Universities of Dresden, Danzig, Braunschweig and Munich, and received his Dipl. Ing. in 1936. From 1936 to 1937 he was assistant at the Institute of Chemical Technology of the Technical University of Munich, specializing in the field of fuel chemistry.

Mr. Mueller was associated with the BMW, Berlin-Spandau, from 1937 to 1939, engaged in the development of reciprocating engines for aircraft and of combustion chambers for jet engines. Since 1939, he was employed as principal test engineer at BMW, Berlin-Zuehlsdorf East, in the field of rocket propulsion, and was promoted to chief of the test section.

From 1943 to 1945, he was chief of the technical office for rocket engine development, and deputy chief of the rocket engine division at BMW, Munich-Allach.

CONFIDENTIAL

TABLE OF CONTENTS

	Page
Part I - Valves	1
Part II - Development of Spoon-Type Pumps and Pumps Designed by BMW and Henschel (Dr. Barske)	5
Part III - Return-Wheel Impellers	7
1. Pressure Stabilization in Return-Wheel Impellers	7
2. Centrifugal-Lift Packings for Use With Return Wheels in High-Speed Propellant Pumps for Rocket Engines	8
Part IV - Film-Cooling Techniques	11
Part V - Test Method for Evaluating Self-Reacting Rocket Fuels	15

LIST OF ILLUSTRATIONS

	Page
Fig. 1 Hydraulic Servo-Controlled Valve	16
Fig. 2 Improved Hydraulic Servo-Controlled Valve	17
Fig. 3 Servo-Valve Solenoid	18
Fig. 4 Servo-Controlled Valve	19
Fig. 5 Bellows Forming Device	20
Fig. 6 Improved Servo Valve	21
Fig. 7 Improved Servo Valve	22
Fig. 8 Cartridge Valve	23
Fig. 9 Diaphragm Valve	24
Fig. 10 Diaphragm Valve	25
Fig. 11 Diaphragm Valve	25
Fig. 12 Spoon Pump	26
Fig. 13 Mixed Flow Pump	27
Fig. 14 Jet-Pump Combination	28
Fig. 15 Pump-Performance Curve	29

CONFIDENTIAL

LIST OF ILLUSTRATIONS (cont'd)

	Page
Fig. 16 Pump-Performance Curve	29
Fig. 17 Pump and Return-Wheel Impeller	30
Fig. 18 Return-Wheel Impeller With Flow-Balancing Blades	30
Fig. 19 Dual Return-Wheel Impellers	31
Fig. 20 Pump With Friction Packing	32
Fig. 21 Disk-Cuff, Packing in Contact	33
Fig. 22 Disk-Cuff, Packing Disengaged	33
Fig. 23 Axial-Cuff Packing	34
Fig. 24 Lip Packing	35
Fig. 25 Diaphragm Sealing Ring	36
Fig. 26 Axial Displacement Seal	37
Fig. 27 Centrifugal Return-Wheel Packing	38
Fig. 28 Centrifugal Seal Packing, Side View	39
Fig. 29 Centrifugal Seal Packing, Top View	39
Fig. 30 Differential Pressure Packing	39
Fig. 31 Rocket Combustion Chamber	40
Fig. 32 Heat Conductivity Diagram	41
Fig. 33 Heat Conductivity Diagram	42
Fig. 34 Test Installation for Rocket Propellants	43
Fig. 35 Electrical Wiring Chart	44
Fig. 36 Water Tank	45
Fig. 37 Test Cylinder	45

CONFIDENTIAL

BMW ROCKET-ENGINE DEVELOPMENT

PART I - VALVES

Valves for rocket engines were designed and developed in the BMW plants at Zuelsdorf. With either self-reacting or nonself-reacting propellant combinations, all possible interaction of the propellants must be avoided, and injection into the combustion chamber accomplished through individual control valves.

An early design for such a valve for the turbopump assembly used a common hydraulic servo fluid, such as water. The mechanism (Fig. 1) operated in such a manner that the servo fluid closed the valve against the flow pressure of the propellant. Positive closing during standstill was provided by means of a return spring. Operation of the valve consisted of bleeding the servo fluid from the servo cylinder according to propellant demands. The servo fluid pressure was supplied by a centrifugal pump, providing higher pressures than the propellant feed pressure.

During operation of the valve, leakage of the propellant into the hydraulic cylinder resulted in a corrosive mixture which could not be flushed out after engine operation, causing corrosion of the return spring. Later improvements led to the use of a protective coating for the spring, which nevertheless suffered corrosion at the ends because of rubbing action. Better sealing between the cylinder and the piston was then provided (Fig. 2) by using an Oppanol-Lupolen gasket material for the acid valve, and Buna gasket material for the hydrocarbon fuel valve.

Dependent upon the operation of the valve solidification due to aging of the gasket material occurred. Of importance in this aging process is the effect of temperature; propellant temperatures above 150°F should be avoided, if possible. Blind pockets which can accumulate dirt should be avoided; the valves should be absolutely leak-proof to avoid accumulation of seepage in the combustion chamber, and later spontaneous ignition and explosion. Greasy water, oil, or even the sweat of a worker's hand, in a valve, can cause decomposition of the sealing material, resulting in damage to the various component parts. Continued use of this valve showed failure of the metal valve seats, and a plastic (LH-100) was substituted successfully. However, at high-operating temperature and flow rates, a slight surface dissolution of the plastic occurred. This was overcome later by using a plastic manufactured by the Techno-Chemie Company, Berlin.

Studies were made to improve the servo valves. Considering the very limited electrical power available in a rocket engine, the switch-actuating moments of the servo valve were kept as small as possible, and an adjustable lever arrangement with a 6:1 or 10:1 ratio was provided. The solenoid was made of a single-wound coil, permitting emergency loads up to 42 w, whereas normal operation loads were limited to 35 w.

This solenoid is shown in Fig. 3. It was designed by the Electro-Mechanische Werke, List and Company, Berlin-Teltow; the solenoid housing (1) and cover (2) are made of soft steel, (German Spec. "Flieg - NR 1042.2"). Solenoid coils (3), armature (5) and plunger (4) are shown. The armature stroke is one half inch and, according to the special shape of the armature, the power of the plunger is nearly constant during the whole travel of the stroke. To prevent magnetization, the plunger guide bushings are made of brass.

Experience had shown that iron, with excellent magnetic properties, was especially vulnerable to rapid corrosion. A factor of paramount importance, during the course of rocket development, was the effective sealing of the solenoid from all gases and vapors. The only exposed openings were the electric leads, cable connections and the armature opening. All leads had to be sealed with special acid- or vapor-resistant rubber sleeves, and the armature opening covered with a soft diaphragm which could be stretched sufficiently to follow the movements of the

CONFIDENTIAL

solenoid armature. Material for the diaphragm was IGAMIT, a TONKA-resistant polymerization product with a polyvinyl base. Due to the softness of the diaphragm, the armature had to be provided with a shoe between the outer end and the servo valve slide (Fig. 4) in order to prevent damaging or piercing of the diaphragm.

The design of the needle valve and seat of the servo valve assembly had to be carefully considered, and the needle seat and guide had to be machined from the same piece of material and finished in one operation. Maximum width of the valve seat had to be 0.010 in., as a width of 0.015 in. often resulted in leakage of the servo valve.

A new development of shutoff valves followed the transition from nonself-reacting to self-reacting propellants. To start a rocket engine designed for nonself-reacting propellants, it was customary, after the ignition flame was burning, to give the injection of hydrocarbon fuel a small lead before introducing the oxidizer into the combustion chamber. This lead of fuel pre-injection was an absolute necessity when operating with self-reacting propellants. A mechanical solution of this problem seemed to be the simplest one. The valve stems of both the fuel and the oxidizer valves were extended through suitable packing glands and guides to the outside of the valve housing, and were actuated by a common lever provided with adjusting screws. The lever in turn was operated by the servo piston. For such a valve the rocket fuel was used as a hydraulic servo fluid, because the mechanical design characteristics permitted a guaranteed separation of the fuel and the oxidizer. However, the main difficulties resulting from such a design were the effective sealing of the packing glands and the guiding of the valve stems. An expansion bellows (Fig. 4) was employed at first. Copper shortage in Germany ruled out all bellows made of TOMBAC (85% Cu + 15% Zn); hence, stainless steel was substituted. The raw material for these bellows was steel strips 0.004 to 0.010 in. thick. Manufacturing of such bellows to meet all requirements was successfully accomplished by only one company in Germany, due to the difficulty of obtaining material without even the smallest inclusion of slag, as this would provide an origin for cracks and would finally result in the destruction of the bellows. Many times, however, bellows which passed all acceptance inspections were destroyed due to material fatigue, even when operated well within limits of the prescribed amount of valve-stem travel. Longer diaphragms were installed, but again material failure due to overheating occurred at the welding joints between the bellows and the valve-seat collar. Later bellows were welded into a cylindrical shape, and for higher operating pressures, several layers of stainless steel sheet were drawn over one another. To corrugate the sleeves, an interior mandrel and an exterior contour roll were used, as shown in Fig. 5. By decreasing the distance between the two pairs of rolls, the rotating tube was corrugated. Resetting is required, as the corrugations are concentric. The manufacturing firm was the Metallschlauch Fabrik Pforzheim in Pforzheim on the Main River. In use, these bellows were found to be susceptible to stresses perpendicular to the axis. The stresses originated from the flow of the liquid propellant and could not be avoided; therefore a protective sleeve was built around the bellows, which could follow the bellows' movement by sliding along the inside wall of the valve-stem housing. (See Fig. 6.) However, during the contraction of the bellows, flow-back pressure occurred within the sleeve even if the sleeve was perforated for drainage purposes. This resulted in a distortion of the sinoidal shape of the bellows' surface, forming sharp corners which subsequently failed and cracked after several operations of the valve.

After making corrections for the first difficulties encountered with the bellows, the development of packing glands for positive sealing of the valve stems was begun. The first few experiments promised success and further development was undertaken. The result was the production of a chevron-type seal, able to withstand 500 cyclic operations of the valve. (See Fig. 7.) The material (LH-100 LUPOLEN-OPPANOL) consisted of flat rolled stock, of a very fine grain structure highly polished. The angle of the chevron-type packing was also very important.

It is pointed out that the servo-unit of the newer type valve (Fig. 4) was not controlled by a needle valve, but by a slide or shuttle valve. Such valves were cheaper and easier to manufac-

CONFIDENTIAL

ture than precision needle valves. Corrosion of the servo-piston return spring was encountered with the use of this new type servo-unit. When retracting the servo piston (shown in the retracted position, Fig. 4), thus closing the main valve, air was drawn in between the servo-piston rod and the guide (housing cover) into the servo piston return-spring housing. The air was often saturated with unburned nitric acid vapors, which corroded the return spring within a short period of time.

A different flow arrangement was provided for the servo fluid. (See Fig. 6.) The solenoid armature pushed the servo slide up, thus the servo fluid (hydrocarbon fuel) passed around the center recess of the servo slide, moving the servo piston to its upper position, which in turn opened the main valve. Closing of the main valve was effected by retracting the solenoid armature, followed by the servo slide, which was actuated by the servo slide return spring, thus interrupting the servo-fluid pressure. The servo-piston spring returned the servo piston to its downward position, and at the same time sucked servo fluid through holes drilled in the servo slide into the spring housing, instead of sucking in the outside air as in previous designs. At the next operation of the servo unit, the servo piston pressed fluid from the return spring housing, around the lowest recess of the slide, into the exhaust port. This modification also necessitated the addition of the valve seat at the upper end of the servo slide, which prevented fluid from entering the spring housing during the opening of the main valve. By controlling the flow of the servo fluid, it is possible, by adjusting the screw above the main valve stem, to regulate the opening speed of the main valve and allow the hydrocarbon fuel a lead of 0.15 to 0.50 gal (approximate quantities for combustion chambers of 2000 to 5000 lb of thrust) before the oxidizer enters the combustion chamber. In order to avoid surging of the propellants and a possible collapsing of the combustion-chamber cooling-jacket walls, closing of the valves should not be too rapid.

A three-way valve is required where the combustion process is started with self-reacting propellants, and nonself-reacting fuels are employed during the main operation period of the rocket engine. Such valves have been developed and designed by the BMW Zuelsdorf plant.

Diaphragm shut-off valves were used most successfully in pressure-feed systems for closing the propellant lines between the pressurized tanks and the combustion chamber.

The pressurizing agent (air, nitrogen) was released when a powder charge was electrically ignited, and opened the special pressure-tank explosive valves. The expansion of the pressurizing agent ruptured the diaphragms before and behind the propellant tanks, and fuel and oxidizer were forced into the combustion chamber. Cartridges of different ignition lags were employed, to enable the hydrocarbon fuel to enter the combustion chamber ahead of the oxidizer.

Figure 8 shows such a valve; the main valve sleeve (2) is mounted in the pressure-tank housing (1). Tube (4) is fitted into valve outlet housing (3), to provide a seal against the pressure in the tank. At the top of the valve, a cartridge (5) is mounted between special insulating packings (6) and (7). Ignition is by a small electrically heated pad (8); after ignition and firing of the cartridge, the bullet destroys tube (4) and drops into the tank.

The cartridge is of standard rifle caliber. For bipropellant systems, an ignition lag between the different propellants is made possible by installing electric resistors in one igniter heating pad, in case a separate valve is employed for each propellant. The stresses in the explosive container are low, and the only difficulties are in leading the electric leads from the outside to the hot pads. Sealing was done by a special cement the exact specification of which is unknown.

Figure 9 shows a typical diaphragm valve. Diaphragm (1) is inserted into the backing plate (2) and clamped into position by spacer (4). Backing plate (2) is machined to a sharp corner (3), which shears off the diaphragm when pressure is applied to the inlet side of the valve (see arrow), hence the sheared-off diaphragm drops into basket (5).

CONFIDENTIAL

The diaphragms must be securely rolled into the frames, provided with sharp edges to cut the diaphragm neatly when the pressure is applied. The diaphragms are caught in a special wire container, which has to be of sufficient size not to restrict the flow of the propellant, regardless of the position of the sheared-off diaphragm in the wire container. The material for the diaphragms should be hard enough to prevent excessive deformation before shearing. The material used by BMW was a hard aluminum compound, or dural, as pure aluminum was entirely unsuitable.

Diaphragms guarantee an absolutely positive seal against leakage. Their installation is also very suitable for missiles which have to be stored fully fueled for an extended period of time.

While the above-described diaphragm shut-off valve has been tested successfully and installed in various rocket engines, electrically controlled diaphragm valves for turbopump-fed systems built into expendable missiles have not been experimentally investigated by BMW, due to the shortage of time. The principle of such an electrically controlled diaphragm valve consists of a diaphragm reinforced by a stiff plate, not subject to bending resulting from the fluid pressure acting on the diaphragm. The support of this plate is electrically retracted from the outside; hence, the plate collapses, shearing off the diaphragm.

Figures 10 and 11 show two types of diaphragm valves. The valve shown in Fig. 10 was developed for unit P-3390A (intended BMW power plant for the Me-163), and can be opened and closed as desired. Opening ② is the entrance and exit of the servo liquid. Diaphragm ③, made from very soft material, closes the valve when the servo liquid presses the diaphragm against grate ④, thus providing a seal against the valve housing ⑤; the propellant in pipe ⑥ can only flow through the grate to outlet ⑦ when the servo fluid pressure is decreased. A pressure decrease would result in an opening and retraction of the diaphragm until the contour of cover ① is reached; hence, a safety against rupture or overstressing is also achieved. If larger types of this valve are required, another supporting grate for the diaphragm would have to be installed in outlet ⑦ to prevent possible rupture. The valve, (Fig. 11) never progressed beyond the design stage. Such a valve is capable of sealing against high operating pressures and high mass flows. Diaphragm ① is strengthened and supported by disk ⑤, which is held in position by a knee lever ⑥. In order to keep the knee lever from collapsing, a wire ⑦ is stretched as shown in Fig. 3. To open the valve, armature ⑨ of solenoid ⑧ cuts off wire ⑦. A seal is provided ⑩ to keep the liquid out of the solenoid. Close fit between armature and drilled hole ⑪ is required to prevent leakage at closed position of valve. Diaphragm is held between spacer ④ and backing plate ③, and drops off after shearing into a container (not shown).

CONFIDENTIAL

PART II - DEVELOPMENT OF SPOON-TYPE PUMPS AND PUMPS

DESIGNED BY BMW AND HENSCHEL (Dr. Barske)

The Henschel-Barske pump was originally designed as a "spoon pump" (Fig. 12). It consisted of a revolving housing *a*, equipped with blades, installed in an overhung position on a shaft *b*. The fuel entered through an orifice *c*, on the front side opposite the shaft, and a hard carbon block, which is not clearly shown in Fig. 12 due to its small size, formed a rubbing seal between the rotating impeller case and the propellant intake line. The "spoon" or "wing" *e*, is placed in the housing *a*, with an opening at its tip facing the direction of rotation. A breather line *f*, to the center of this pump is opened when starting, to assure complete filling of the pump housing *a* with fuel. After the maximum pump pressure has been attained, the line *f*, can be closed.

When the housing *a*, is filled completely, the internal pressure is $a/2g n^2$, where *a* equals the specific gravity, and *n* equals the circumferential velocity. At 0 output, a ramming pressure $a/2g n^2$ is formed in front of the spoon opening, so that the total pump pressure amounts to $a/g n^2$. It should be noted that the shape of the spoon did not influence the pressure ratio, which is the ratio of the actual to the theoretical pressures; up to 82% of the theoretical value was attained in tests. The first spoon was shaped according to the flow profile, and was sharply curved beyond the intake opening to follow the radial direction of flow. The second spoon avoided this curvature, and used a wide arc entering into the radial direction of flow. The third spoon was a simple radial pipe, closed on the bottom and slotted for the intake. The fourth spoon was also a pipe slightly curved on the outside. The interiors of spoon forms 1 and 2 were provided with diffuser-like expanding ducts. Spoon forms 3 and 4 had uniformly large flow cross sections with abrupt changes in the intake and outlet of the spoon at the main pressure pipe.

Practically all these spoon forms resulted in the same pressure ratios, which had not been expected. Differences were noted in pump efficiency since the friction horsepower in fast running pumps is evidently of considerable importance. The spoon forms 3 and 4, due to their shape, created a vortex which not only extended in the tangential direction but also in a radial direction. The friction surface of spoon form 2 was too large, even though its shape was theoretically the best. In the design of spoon intake openings, it appeared that a small slot extending in an axial direction was the best for attaining a good pressure ratio. Actually, however, a slot extending in a radial direction proved superior. The ideal deflection of the flowing fluid, especially in spoon form 1, is obtained through the difference of the circumferential velocity at the beginning and the end of the spoon slot.

Pumps of this design are especially suitable for high pressures and low-delivery volumes. Previously the plunger-type pump was used exclusively for this purpose.

Even though spoon pumps are simple and sturdy, many new developments and improvements in their design were possible. The pump control of the fuel rate is of primary importance if the pump must deliver highly sensitive and easily vaporized fluids over a large control range. The pump development was greatly influenced through the demand for pumps of higher performance; it was required that the pump be operationally safe, cheap and simple in design. The first pump developed by Henschel-BMW operated at 24,000 rpm, with a circumferential velocity of about 310 ft/sec at a diameter of 2.95 in. This development had an unexpectedly high efficiency.

The first pump design had a revolving housing and one or more spoons. The second pump design had a stationary housing and tangential diffusers open on both sides, extending to the outside by using an impeller with radial blades (Fig. 13) and was considered superior to the first design. The ratio of the radial velocity of the propellant to the tangential velocity at the blade tips in the first pump design produced a good efficiency and pressure number, which were also attained in the second pump design.

5
CONFIDENTIAL

CONFIDENTIAL

To maintain a minimum friction horsepower, the external circumference of the pump wheel must be kept small. The clearance between the blade and the front plate should be between 0.020 and 0.050 in. If the clearance is reduced to about 0.007 in., the friction horsepower increases considerably.

Satisfactory operation of the pump at high delivery volumes is of decisive importance in further development of the pump. By combining a jet pump (Fig. 14) with the main centrifugal pump, and pumping the propellant with the aid of a special diffuser on the centrifugal pump, a pressure between 1.1 and 2 atm absolute is produced in the intake line of the centrifugal pump, depending upon the amount of fuel flowing through the main diffuser of the pump.

An attempt was made to replace this arrangement with a booster screw in the form of an inlet axial or a half-axial fan. Tests indicated that the high-speed fans were unsuitable for this purpose - evidently the pressure increase across the fan, even at variable fuel quantities, was too low, and resulted in a type of cavitation between the inlet fan and the main pump rotor. The low-speed fan yielded better results. Unfortunately, these tests could not be continued, owing to more urgent requirements. In addition to the inlet fan, numerous other pump inlet forms were tested in connection with varied jet-pump performances. Extensive work was done to determine the radial and axial clearance between the pump rotor and the housing. The radial clearance was kept at about 0.02 in. The first Henschel-BMW pump with high-delivery volume was used in the rocket engine 109-509 for the Me-163A. The rocket thrust was varied by changing the injection pressure at constant-turbine pump revolutions per minute with the aid of a by-pass control (Fig. 14). When regulating the thrust by means of the by-pass, the pressure may be reduced, producing a separation of the fluid from the walls of the exit diffuser of the pump. This produces strong shocks and oscillations in the pressure line, and causing frequent breakage of the 1-mm seamless-steel pressure line. Flexible lines suddenly expanded in length when the pressure was decreased, whereas normally they should have contracted. It was suspected that the low number of rotor blades (three) used in the design caused these irregularities, and measurement of the frequency oscillations showed a possible correspondence to the number of blades. Rotors were then constructed with 5, 6, 7, 8, 12, 16, and 24 blades, but little effect was noted. The location of the diffuser outlets in the pump housing were varied, with no success. Different diffuser forms were tested, which produced various results; the problem was finally brought under control with a loss of only 5 atm in the maximum supply pressure of the pump. In further cooling improvements of rocket combustion chambers, it was found that the pump pressure could be reduced further, due to decreased pressure losses. In order to improve operation, the pump-rotor diameter was made smaller. This resulted in a pressure increase, which led to the determination of the pressure ratio at various radial clearances between outer-rotor diameter and housing. The most favorable clearance between housing and rotor was found to be 4.5-5 mm. Smoothness of operation was also considerably increased by decreasing the diameter of the rotor, and the thrust-control problems were improved. The original diffuser form could also be used again.

It must be pointed out that the delivery volume of the pump depends upon radial clearance. The pump (Fig. 20) built for the turbojet 109-003 ($D_{\text{rotor}} = 60$ mm, $n = 30,000$ rpm, $Q_{\text{max}} = 68$ m³/hr) could be regulated without disturbances from 0-50 atm pressure with little change in the flow rate. This pump had a diameter of about 2-3/8 in., and delivered 30-35 gal/min at an operating speed of 30,000 rpm.

The pump curve of the Henschel-BMW types will be briefly discussed. Typical pump curves are shown in a plot of pressures and delivery volumes (Fig. 15). The best efficiency lies at the peak of the curve. If the pump delivery volume is increased by enlarging the exit diffuser, then the peak of the curve begins to flatten (Fig. 16). This flattening of the peak can be delayed to a certain degree by either enlarging the intake-pressure line of the pump, by increasing the propellant flow, or by broadening the rotor. However, certain precautions must be taken in order to assure complete filling of the pump interior.

CONFIDENTIAL

PART III - RETURN-WHEEL IMPELLERS

1. Pressure Stabilization in Return-Wheel Impellers

Pumps of low rpm require stuffing boxes or other friction seals to keep the fluids from the pump bearings; however, in pumps of high rpm it is necessary to provide two seals. The pump must be sealed tightly during standstill and low rpm, and usually a seal of the ordinary friction type is used. For high rpm it is necessary that a dynamically effective seal be designed.

At high rpm, the friction heat of the ordinary friction-type seal is so great that the frictional contact is destroyed, and precautions must be taken to relieve the frictional contact above a certain boundary rpm. A dynamic seal must be designed to become effective at slightly below this boundary rpm, and to remain effective at the high-operating rpm.

In the following, mathematical formulas are presented for the pressure conditions in return-wheel and pump impellers. In Fig. 17, the return-wheel impeller combined with the pump impeller is schematically illustrated. It is assumed that a constant pressure prevails in the suction line, although this pressure will vary within certain limits, depending upon the delivery volume. The following symbols are explained:

P_a = maximum pressure in the suction line

D = outside diameter of the return-wheel impeller

d_1 = hub diameter of the return-wheel impeller

d_2 = inside diameter of return-wheel impeller

n = rpm of the pump at which the return-wheel impeller should become effective

a = specific gravity

The pressure on the outside diameter of the return-wheel impeller at revolutions per minute n may be given as:

$$P = P_a + P = P_a + aw^2/32g (D^2 - d_1^2)$$

It is assumed that the main impeller is an open centrifugal impeller and the angular velocity is: $w = 2\pi n/60$.

From observations of various pumps, it has been seen that the fluid on the unbladed side of the return-wheel impeller revolves at one-half the impeller speed, and the pressure set-up determines the necessary return impeller-blade diameter d_2 , according to the following equation:

$$P = P_a + \frac{a}{32} \frac{w^2}{g} (D^2 - d_1^2) = \frac{a}{2g} \frac{w^2}{4} (D^2 - d_2^2)$$

Pressure in fluid leaking to return wheel = Pressure set up by return-wheel impeller

Special cases, which require special consideration when designing a return-wheel impeller, are as follows:

CONFIDENTIAL

a. If pumps are operated with varying delivery volumes or at high altitudes, the pressure in the suction line may drop below the normal suction pressure. In this case, there is danger that the pressure in the return-wheel impeller will force the propellant out of the return-wheel impeller and back past the main-pump impeller. Pressure recovery would then occur in a series of pulsations; thus through a back flow of the fluids from the delivery line, the main impeller and the return-wheel impeller would be refilled. This pulsation effect can be counteracted by using small counter impellers a on the unbladed side of the return-wheel impeller, as shown in Fig. 18. The formulas for the equilibrium conditions in these counter impellers may be derived similarly to the above equations.

b. Pressure in the suction line may be increased by using a feeder pump. In this case the over-all diameter of the pump becomes very large if a single large-diameter return-wheel rotor is used, and the high friction horsepower resulting from this large unit will cause a vapor lock. By using two smaller return-wheel impellers connected in series, the over-all diameter may be kept small.

c. If operational conditions require that the dynamic seal become effective at low revolutions per minute, it has proved advantageous in turbojet gasoline pumps to provide a second-stage return-wheel impeller with a larger impeller diameter (Fig. 19). Both return-wheel impellers operate during starting, but the second impeller evaporates the propellant due to the high tip speed, and only the friction horsepower of the smaller impeller remains.

2. Centrifugal-Lift Packings for Use With Return Wheels in High-Speed Propellant Pumps for Rocket Engines

Sealing of the pump shaft on the bearing side of propellant pumps was unsatisfactory, and when BMW commenced work on independent rocket power plants in 1940, no packings for high-speed pumps were available which were suitable for BMW fuels.

Due to the constant frictional contact of the packings, the BMW pumps required a packing capable of withstanding a circumferential speed of 115 ft/sec. A German study showed only one type of packing which would meet such requirements. This was the graphite packing of the Jaeger pump (Jaeger, Leipzig) which could withstand a circumferential speed of up to 122 ft/sec, and which has been described earlier in reports on Walter power plants. In the Jaeger pump, the friction packing was located axially between a case-hardened steel plate and a synthetic-graphite compound manufactured by the Siemens-Plania factory for carbon products, Berlin, which consisted of graphite powder and a binding agent. Siemens succeeded in finding a binding agent that was resistant to T-Stoff, but none that was resistant to Salbei. The main disadvantage of the Jaeger packing was the axial space requirement, which is particularly noticeable in single-bearing pump wheels, which are used exclusively for the Henschel-type BMW pumps.

A new development was therefore undertaken, consisting of a self-lifting friction packing for low speeds, combined with a return wheel which served as packing for high speeds. The first efficient packing was employed in high-speed gasoline pumps of a propeller-jet engine which operated at 30,000 rpm. A rotating flexible disk (Fig. 20) runs on a highly polished lip of light metal. The cuff of the disk is pressed against the stationary lip by means of a retainer spring, and at high speeds the centrifugal force on the disk and the spring lifts them off the lip. Figure 21 shows the cuff in contact, and Fig. 22 shows the cuff in the raised position. The travel of the disk and the spring must be held to a minimum, to prevent the cuff from splitting. For this reason, the backing block of the disk allows the spring to move only about ten-thousandths of an inch before contact is made.

The first tests with these seals showed very good results; however, mass production resulted in a slight eccentricity in the seal, due to excessive play in the bearings producing fatigue

CONFIDENTIAL

of the material and failure of the disk seal. Increased spacing of the bearings in the pump shaft, as shown in Fig. 20, was moderately successful in reducing this eccentricity.

For Salbei pumps, an attempt was made to convert the radial packing into an axial packing, while maintaining the same sealing principle. This was prompted by the general observation that the axial deflection of a shaft is only about 10% of its radial eccentricity. The plastic disk is pressed against the stationary rear wall of the casing of the impeller chamber by means of a spiral spring, Fig. 23. In operation, the centrifugal force expanded the conical-shaped cuff, and contact with the wall was broken at about 3000 revolutions. The plastic material of the disk was entirely unsuitable for Salbei, and the packing would not seal tightly when the unit was standing still, or when there was a low-static pressure in the pump intake line.

The design shown in Fig. 24 was tested. This type of packing was called "lip packing". The lifting was again radial, by means of the springy characteristics of the synthetic material itself. The procurement of Salbei-proof resilient materials was very difficult, and the synthetic material employed for a short time was very poor. Its quality varied a great deal, which made it exceedingly difficult for the experimental engineers to determine the exact cause of the failure. Newly installed packings were perfect when the unit was not in operation, but short runs would result in excessive leakages, as the sealing rings wore oval. The cause of this failure, as described earlier with cuff-type packing, was due to the radial eccentricity of the rotor. Some improvement was obtained by moving the first bearing of the pump rotor closer to the packing; however, the time of successful operation was still short. Figure 25 shows a design which uses the fuel pressure created by the return wheel. The pressure, acting upon diaphragm b thru holes a, moves a resilient spring disk c which supports the sealing ring, and disengages the seal from the shoulder of the return wheel, preventing frictional surface contact during high-speed operation. When the pump is shut off, spiral spring c returns to the packing surface of its seat, d. The early design was too stiff and prevented a smooth lifting and recontact.

A new sealing method was attempted in the design shown in Fig. 26. No synthetic materials of any kind were used, and the actual sealing was accomplished by the use of a valve seat. The pump impeller was provided with a sealing surface at a, which closed against a seat on the housing. This design works perfectly, providing the rotor does not touch the seat until shortly before the unit is shut off, otherwise seizing marks will result, which while they do not cause any appreciable leakages, cause a rapid seizure of the contact surfaces. The unseating may be accomplished in various ways either by centrifugal force that produces an axial displacement of the shaft by a coarse-screw thread, or by allowing the fuel pressure itself to unseat the rotor by means of a diaphragm or a piston. This type of packing was used for a rocket-propellant pump unit which consisted of an electric motor, Tonka pump, and Salbei pump. Helical gears were used to unseat the impeller, and the unit was operated 650 times - after which it was no longer needed because of the change-over to self-reacting fuels.

During the development of Project 3390A (109-510), it was not possible to equip the pumps with packings according to Fig. 26. Other methods had to be found; Fig. 27 shows the result of this work. This centrifugal packing, together with the return wheel, stands up perfectly against Tonka. A disk a is slotted in segment-shaped patterns, cross section Fig. 28 and side view Fig. 29, and moves in direction X, Fig. 28, when rotating. Lifting begins at about 4000 rpm. This type of packing is unsuitable for Salbei; it was used for a while by BMW, however, it was required to make the disk of stainless steel, since other Salbei-resistant materials soon lost their springy qualities. The manufacture of these disks is very expensive, because of the rapid wear and the dulling of tools used in making the slots. Dural, as used for Tonka packings, was found unsuitable.

Therefore a new design (Fig. 30) was developed. (See Fig. 13.) This packing was used by BMW for Salbei and Salbeik (HNO_3 plus FeCl_3), and is known as a differential pressure packing. Disk b is pressed against the sealing surface of return wheel c by the static pressure in the in-

CONFIDENTIAL

take line when the pump is shut off; a pressure of 1.1 atm (gage) permits complete sealing. Disk b is inoperative when the unit is in operation, because the action of the return wheel does not permit any propellant to flow past the disk. The great advantage of this arrangement is that the disk is fixed to the housing, and not subject to centrifugal forces. Disadvantages are the uncertain qualities of the synthetic materials and the crystallization of the propellants when the unit has been shut down for a long time, the fine crystals wearing the sealing disks as the pump is started up.

To obtain the highest efficiency, and to maintain the performance and characteristics of pumps of the same design, it is necessary to machine the housings and rotors of the pumps. When the pumps were under development, all parts were made from solid steel billets. For production, it was contemplated to have the pump-housings die forged together with the diffusers, to eliminate outside machining operations. The impellers and blades were also to be die forged. Pumps made of V2A (stainless steel) were more difficult to machine than those of normal steel or light metals. For reasons of economy, the housing was made of normal steel plated with a layer of chrome and dural, and the pump shaft was welded to the impeller. The pump shaft consisted of normal steel (Fliegwerkstoff 1030.2) and the rotor of V2A-ED. The packing (Fig. 30) was not used for R-fuel (Tonka) because only chrome-tanned leather successfully stood up against Tonka; however, this packing was stiff, and would not seal tightly under low static pressure. The vent between the pump case and the bearing case can be made from aluminum castings (Silumin X), and only the sealing and bearing surfaces need machining.

When assembling Salbei and Tonka pumps, the exact play as specified by the assembly drawings must be maintained. In Salbei pumps, the packing material must not come into contact with grease, and should not be handled with sweating hands. During transportation of the engine, the pumps must be packed in such a manner that the oil from the gears will not reach the packings. The assembled packing which has not come into contact with Salbei has an almost unlimited life. It is advisable however, after each operation, to drain the fuel from the unit through the scavenging pipe to prolong the life of these packings.

CONFIDENTIAL

PART IV - FILM-COOLING TECHNIQUES

Cooling of the inner combustion-chamber walls is one of the critical problems in rocket engineering, since it becomes more important with the use of high-calorific fuel combinations.

Early in 1934, an internal-cooling method (film cooling) was suggested, in which the surface of the combustion chamber facing the ignition area would be sprayed with a cooling agent such as water, hydrocarbon, or even the fuel component of the propellant combination. Water was not favored because of the additional weight. By using a hydrocarbon or the fuel itself as a cooling agent, additional cooling is obtained during the vaporization process without adding the extra weight of the cooling medium.

With the transition from nonself-reacting propellants, $\text{HNO}_3 + \text{CH}_3\text{OH}$, to self-reacting propellants, such as $\text{HNO}_3 + \text{Tonka}$ at BMW, the thermal stress of the combustion chamber was increased to such a degree that any previous means of cooling (exterior cooling) no longer afforded reliable operation for any length of time, especially when the operation required the frequent stopping and restarting of the unit.

A rocket engine (Fig. 31), equipped for regenerative cooling using nitric acid, was provided with a new injector head for film-cooling tests. The various parts of the rocket engine are as follows:

- (1) Inner jacket of the combustion chamber
- (2) Outer jacket of the combustion chamber
- (3) Filler block for guiding the coolant flow past the throat
- (11) Coolant inlet
- (12) Coolant outlet

There was no helical flow of the coolant, but rather a smooth axial flow. The injector head was formed in two parts, the body of the nozzle 41 and the nozzle ring 42 welded together. The pattern of the impinging propellant jets is shown 43 and 44.

The original injector heads 4 did not have holes for film cooling in the nozzle ring 42, but later designs incorporated a nozzle ring with 30 radial holes. The fuel component of the propellant sprayed from these holes into the narrow space between the nozzle ring 42 and the inner jacket 1.

Results showed that the cooling propellant consumption could be improved. The explanation is as follows: Internal cooling of the combustion-chamber walls is so effective that the danger of over-heating is removed. By injecting an excess of oxidizer into the combustion chamber to react with the propellant injected for film cooling, a marked improvement of the propellant consumption was obtained, such that the over-all consumption was in many cases reduced.

The results of these experiments were of course questionable, even though accurate measuring methods were used, and many tests were conducted. Finally, the contents of the propellant tanks were measured and the consumption during extended operations checked. The numerical results are tabulated in Table I. It should be noted that, after the first successful tests, BMW substituted dural inner jackets and injector heads for the usual steel (V2A or SAS-2) with excellent results. With film cooling, the weight of the 109-718 unit was reduced 30%, and the production time about 80%. The maximum service life was increased considerably, and allowed over 1500 operational runs of a maximum of 4 min each of the turbojet-rocket combination

CONFIDENTIAL

109-718, without any operational difficulty. During later overhaul of these rocket engines, the aluminum combustion chamber did not show any deformation and did not require an arbor press for disassembly, as required in the case of the steel combustion chambers.

These developments were so rapid that they prevented investigation and evaluation of the operational conditions in the combustion chamber on a broader basis. Each combustion chamber (cooled by the film-cooling method) was found to be covered on the inside with a layer of carbon deposit, 0.005-0.01 in. thick. As long as this layer remained thin, good adherence to the combustion-chamber wall could be expected; however, if a certain thickness was surpassed, the carbon layer would peel off and a new layer would immediately form; hence there was always sufficient protection. A correct injection-head design will result in an even and thin layer of carbon deposit along the interior of the whole combustion chamber, terminating shortly behind the throat section of the nozzle.

Combustion chambers using a xylydine composition for the fuel component of the propellants operated successfully; however, a combustion chamber using Tonka-250 required an approximately 16% thicker film, in order to perform satisfactorily. Tonka film cooling enabled the continuous operation of rocket combustion chambers for durations of from 3 to 4 hr at chamber pressures of 425 psi. It can be expected that the described film-cooling method will also allow operating pressures of from 1100 to 1500 psi.

Three different characteristics can be observed from film cooling:

- (1) A part of the rocket fuel breaks down into a layer of carbon deposit which forms a continuously renewed coke or graphite insulating layer.
- (2) A liquid layer of fuel passes over the solid-coke insulating layer.
- (3) A vapor layer forms over the liquid-fuel layer. A large drop in temperature through the vapor layer results, due to the consumption of the large amount of heat which is needed for the cracking and vaporization process of a part of the rocket fuel.

The three mentioned features show different characteristics at different sections in the combustion chamber. In the vicinity of the injector head the liquid film will be mainly effective, due to the high mass flow of the propellants resulting in a comparatively low thermal load. The carbon film is very thin, and the vapor film likewise will not be appreciably thick. The closer we move toward the exhaust nozzle, the heavier the carbon and vapor films will be, and the thinner the liquid film. Around the sonic cross section of the nozzle, the solid layer will thin out again, possibly due to the exhaustion of the fuel film or to the high rate of flow of the gases, which prevents an accumulation of a heavy layer of carbon deposits.

The following conclusions can be drawn for a film-cooling layout: It is not only important to inject a corresponding amount of rocket fuel for film-cooling purposes within a certain period of time, but the proper amount of fuel injected at the correct injection velocity must be determined, in order to obtain highest efficiency at minimum propellant consumption. The configuration of the combustion-chamber shape is likewise highly important.

Considering the design of a combustion chamber, the following is noted:

- (1) With regard to heat conductivity by means of convection, a higher insulating factor is given to the vapor film than to the carbon film, considering that the heat conductivity coefficients of vapor and gases are superior to carbon, graphite, etc., by the tenth power. These values may be correct for low temperatures, but at rising temperatures a remarkable decrease of the heat-conductivity coefficients occurs with regard to carbon graphite, so far as can be concluded from several test results.

CONFIDENTIAL

(2) With rising temperatures, a better heat-conductivity coefficient for gases and vapors can be expected. The greatest increase results at the point where the dissociation of the gases occurs; however, it is possible to retard the dissociation by increasing the combustion-chamber pressure. For further references a few curves are shown, demonstrating the heat conductivity of coke and graphite, and of air and hydrogen. The sharp rise of the hydrogen curve is due to the early dissociation at a low pressure of 14.4 psi (Figs. 32 and 33).

(3) The carbon layer is able to protect the combustion-chamber walls from the radiation; but more important is the protection against corrosion of possible hot acid sprays, or free oxygen, which due to interior turbulences is a common occurrence in rocket combustion chambers.

The amount of heat required to vaporize and solidify the rocket fuel for film cooling is important, and it may be possible to shift the effective position of the film within the combustion chamber by varying the fuel-injection pressure and the thickness of the film, which is a function of the amount of film coolant used.

For the first design layouts of extremely high-thrust rocket engines, it may be advantageous to inject the fuel component which is required for the film-cooling effect separately from the main rocket fuel, using a separate tank and injection pump as well as a separate injection system.

The following advantages may be derived from such a layout:

(1) Independence in the choice of injection pressure and quantity of the main rocket fuel. Possibly, an excessive injection pressure for the film-fuel component can be employed in order to protect the thrust nozzle at a minimum film-fuel consumption during the cooling process. Simple, reliable pumps can be designed to fulfill such a task.

(2) Possibility of varying the composition of the cooling film

(3) With regard to the film composition, it may be pointed out that only the chemical component which is actually responsible and required for the creation of the cooling film is being cracked, and it may be possible to employ a rocket fuel of a very high specific impulse, without diluting such a fuel with a hydrocarbon agent in order to obtain the required film; hence no influence with regard to specific impulse or density of the main fuel will result.

CONFIDENTIAL

TABLE I

Experiments With Tonka Film Cooling

Propellants

Salbei: 99.5% nitric acid and 3% ferric trichloride

Specific weight: $w = 1.52$

Tonka: 50% by volume triethylamine + 50% by volume xylidine

Calorific value: $9842 \frac{WE}{kg}$; specific weight: $w = 0.86$

Stoichiometrical mixture ratio: 1:4.45

Film consumption, lb/ft^2 (combustion-chamber area) /sec 0.47

Combustion-Chamber Specifications

Total mixture ratio:	1:3.2	1:3.8	1:3.2
Mixture ratio at center:	1:5.35	1:6.38	1:5.35
Thrust T, lb	2200	2200	4750
Combustion-chamber pressure, psi	310	310	440
Specific-propellant consumption lb/lb sec	0.0051	0.00515	0.0048 - 0.0049
Stay time, sec	3.45×10^{-3}	3.4×10^{-3}	2.2×10^{-3}
Inner-jacket material	dural	dural	dural
Injector-head material	dural	dural	dural

CONFIDENTIAL

PART V - TEST METHOD OF EVALUATING SELF-REACTING ROCKET FUELS

It is evident that the "falling-drop" test method for rocket propellants is very uncertain as a means of evaluating self-reacting rocket-fuel combinations. Under certain conditions, there may be great differences between the results of the above type of test and a spray-nozzle test.

An installation for spray tests which uses standard machined parts is described. Figure 34 shows a schematic drawing of such an installation. Two pipes lead from a compressed air bottle, thru a main valve and high-pressure gage, to pressure-reducing valves. Pipes from the low-pressure side of the pressure-reducing valves lead to small water tanks, that may be either pressurized or opened to the outside atmosphere by means of three-way selector valves. The water tanks are connected to separate injection cylinders through standard solenoid valves. Each cylinder contains a piston, to separate the water and the test propellant. The pistons are connected to rods equipped with handles as shown.

The operation of the test apparatus is as follows: At the start of the test, the pistons are at the top of the injection cylinders; the solenoid valves are closed; and the three-way selector valves are set for the use of the compressed air. When the solenoid valves are turned on, the air pressure forces the propellants from the cylinders and through a spray nozzle by means of the servo fluid (water) acting on the injection pistons. The propellants impinge, upon leaving the nozzles, and by rapidly opening and closing the solenoid valves it is possible to determine the time required for ignition. An electrical switch (Fig. 35) permits a range of opening time for the solenoid valves of between 0.005 and 0.5 sec. It is possible to determine the shortest opening time for the valves at which the impinging jets will ignite. Comparison of these ignition periods afford a satisfactory way of evaluating propellant combinations.

To refill the test cylinders, the pressure on the water tanks is relieved by means of the three-way selector valves. The solenoid valve is opened and new charges drawn into the test cylinders, by raising the handles attached to the injection pistons. To facilitate the filling process, it is advisable to have the test cylinders easily removable by means of quick-disconnect fittings, to allow new cylinders to be installed when testing other propellant combinations.

The electrical arrangement (Fig. 35) includes a main switch for controlling the two solenoid valves, which are connected in parallel. Closing the main switch energizes relay A, which interrupts the circuit to the solenoid valves by means of a circuit breaker a. By introducing various condensers, it is possible to vary the operating period of the relay. The condensers are connected in parallel with the relay, and are placed in the circuit by means of suitable switches. A rheostat may possibly be used in front of the relay, depending upon the characteristics of the relay. To hold the solenoid valves open while refilling the test cylinders, a filling switch breaks the circuit of the relay.

To prevent the injection nozzles from clogging up, it is advisable to make the injection holes not less than 0.032 in. in diameter. This corresponds to a Tonka consumption of approximately 0.54 cu in./sec at 28.5 psi. Using a test cylinder 1 in. in diameter, the piston travel would be about eleven-sixteenth inch per second.

The injection holes for the Salbei (98% nitric acid) should be about three sixty-fourth inch in diameter, which will give a consumption of approximately 0.925 cu in./sec at 28.5 psi. Using a test cylinder 1 in. in diameter, the piston travel would be about 1.2 in./sec. The water tanks (Fig. 36), for a test lasting 4 sec, should have a capacity of between 10 to 13 cu in. Figure 37 shows a cylinder of about the required size for a test lasting 4 sec.

CONFIDENTIAL

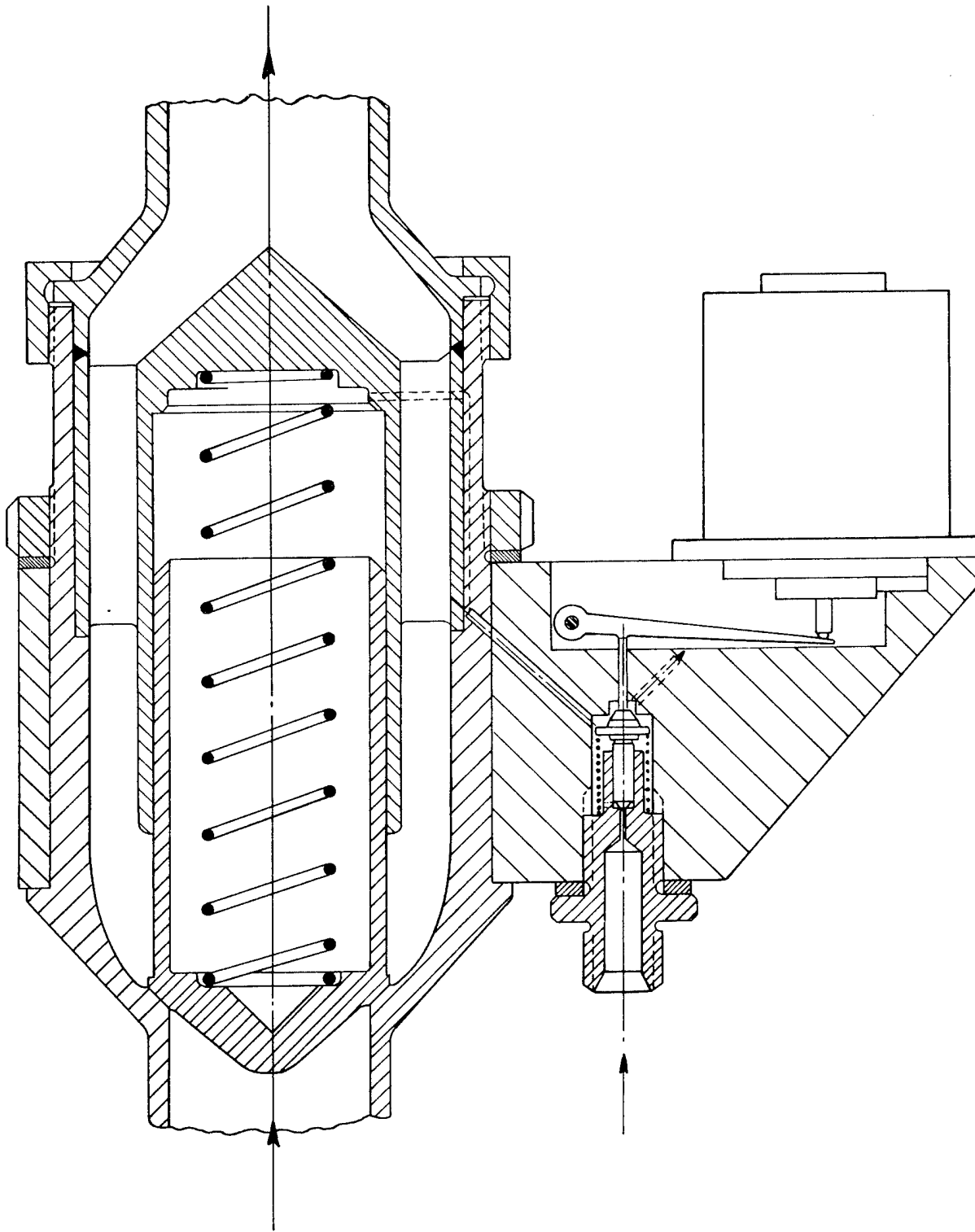

Fig. 1 - Hydraulic Servo-Controlled Valve

CONFIDENTIAL

CONFIDENTIAL

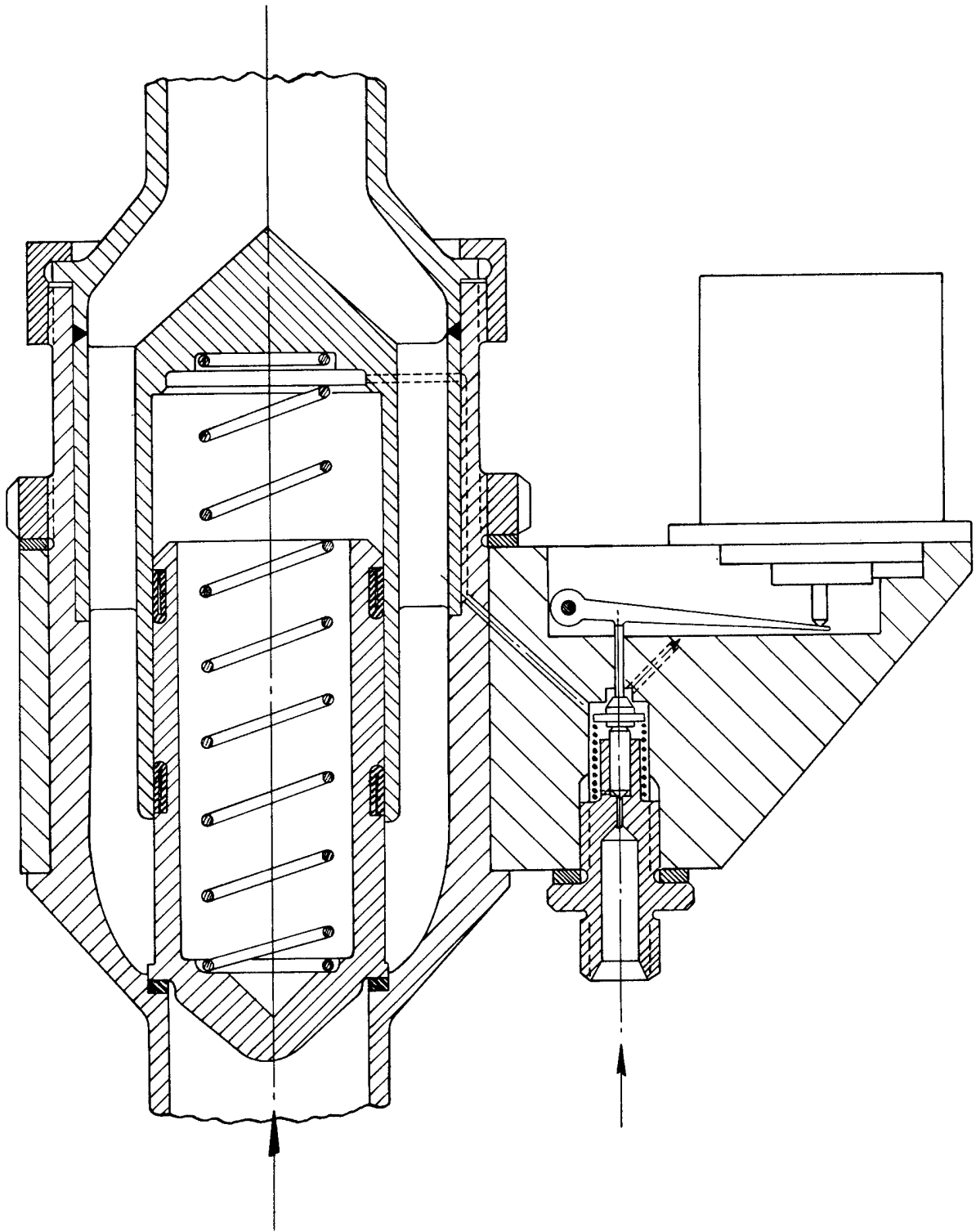

Fig. 2 - Improved Hydraulic Servo-Controlled Valve

CONFIDENTIAL

CONFIDENTIAL

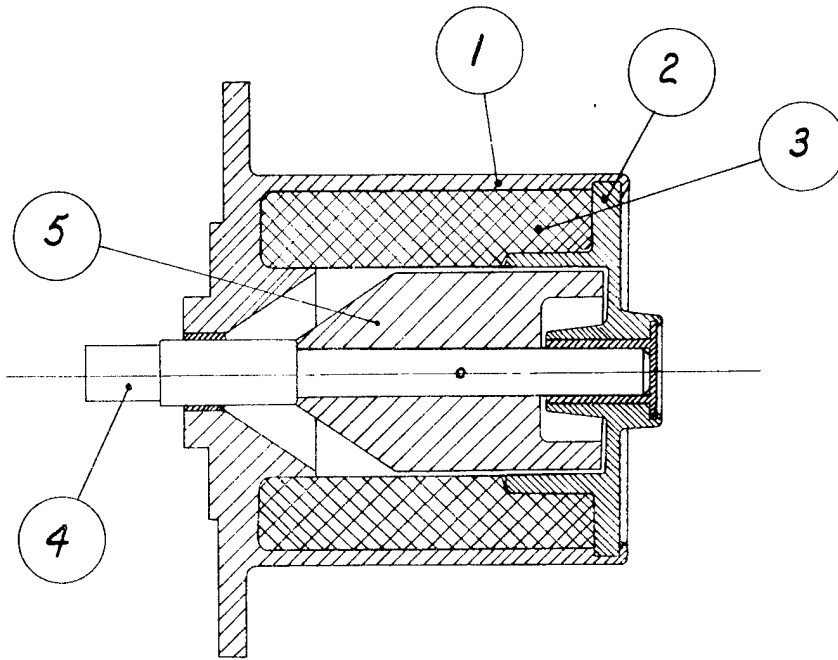

Fig. 3 - Servo-Valve Solenoid

CONFIDENTIAL

CONFIDENTIAL

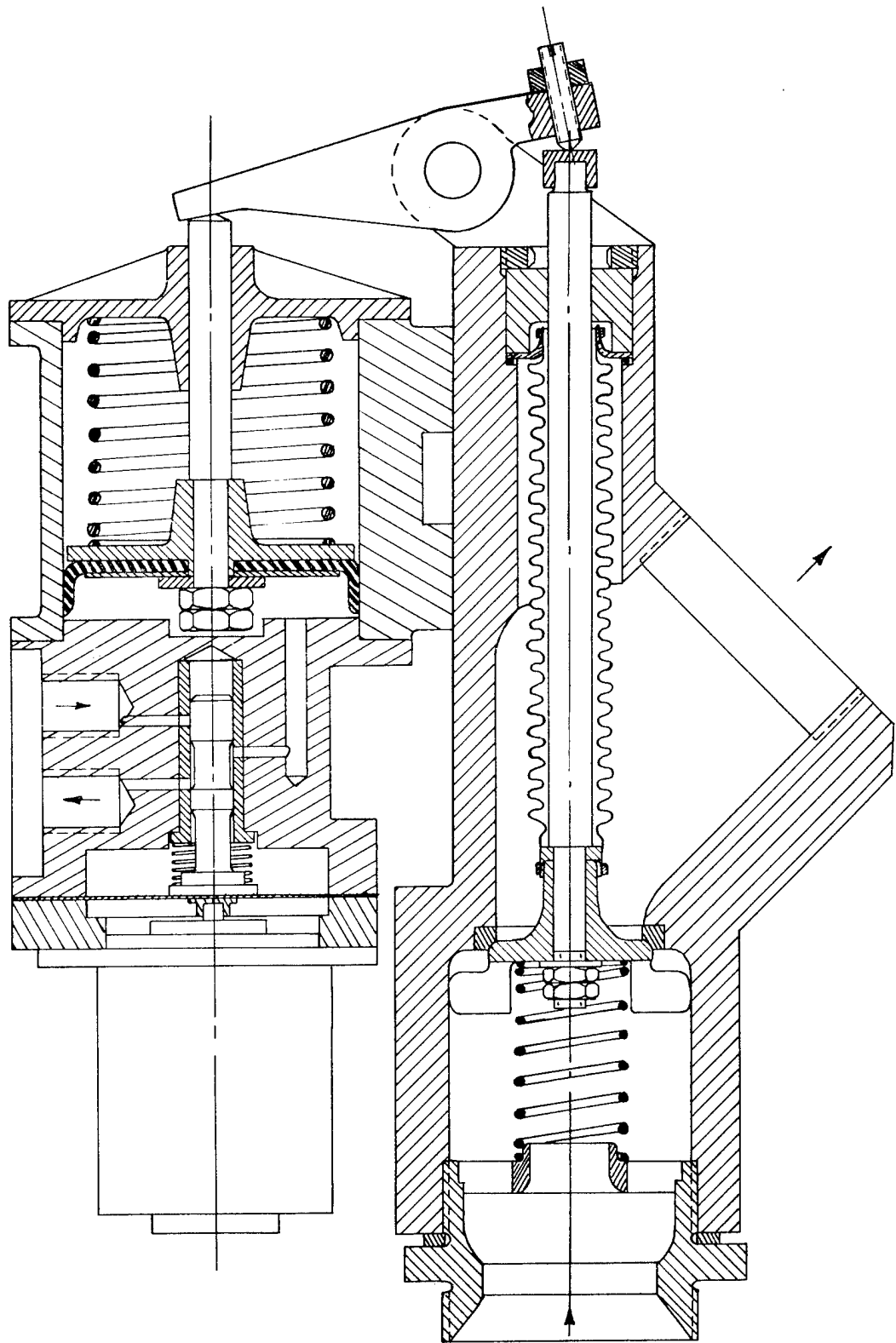

Fig. 4 - Servo-Controlled Valve

CONFIDENTIAL

CONFIDENTIAL

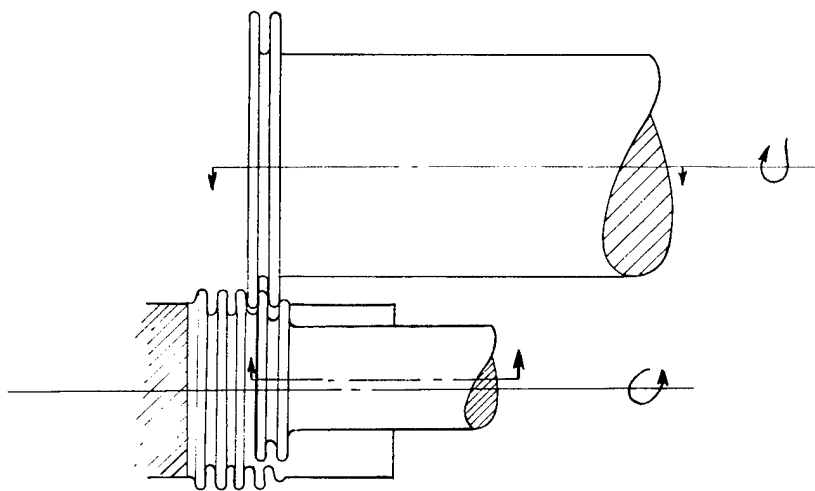

Fig. 5 - Bellows Forming Device

CONFIDENTIAL

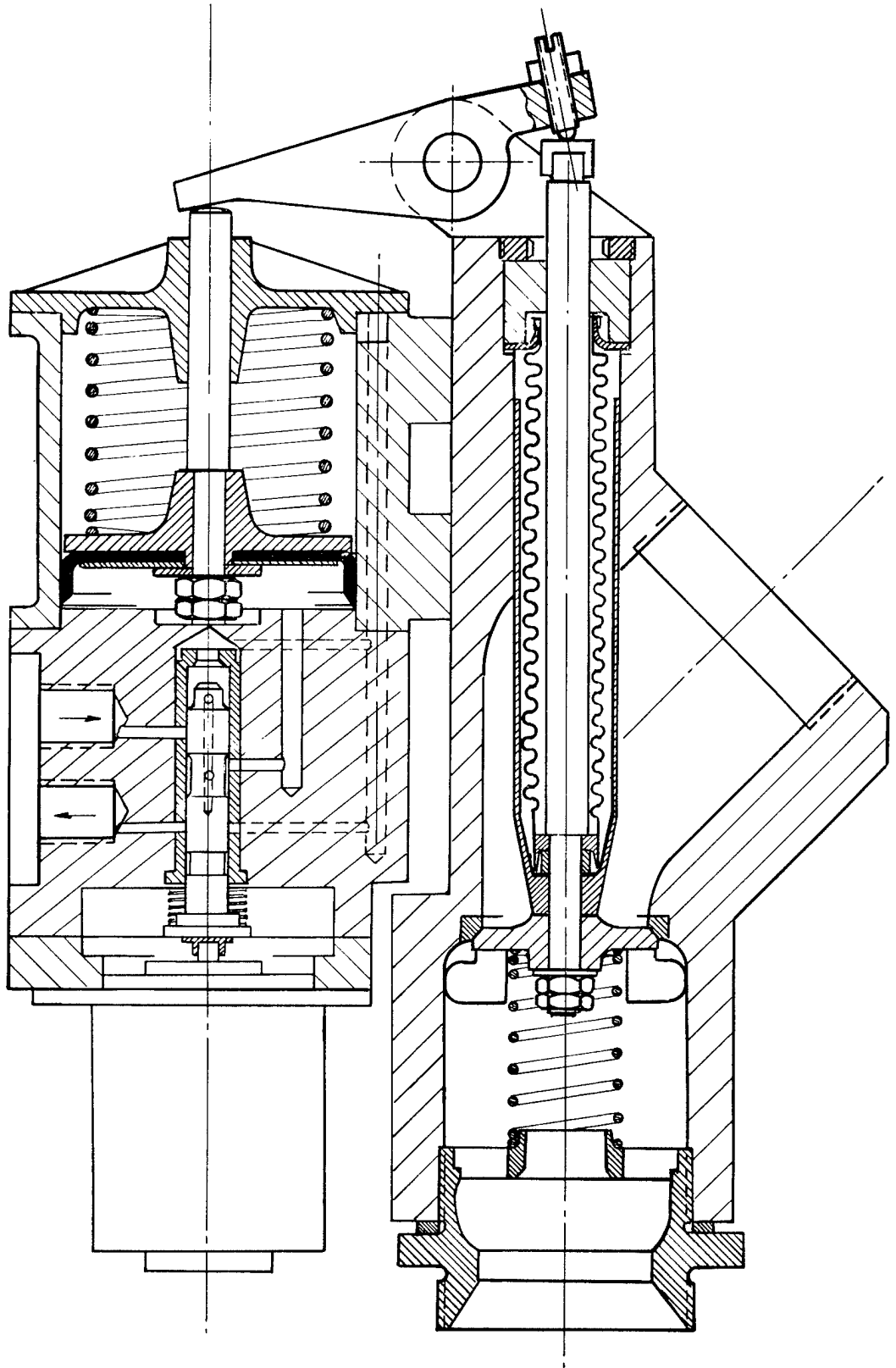

Fig. 6 - Improved Servo-Valve

CONFIDENTIAL

CONFIDENTIAL

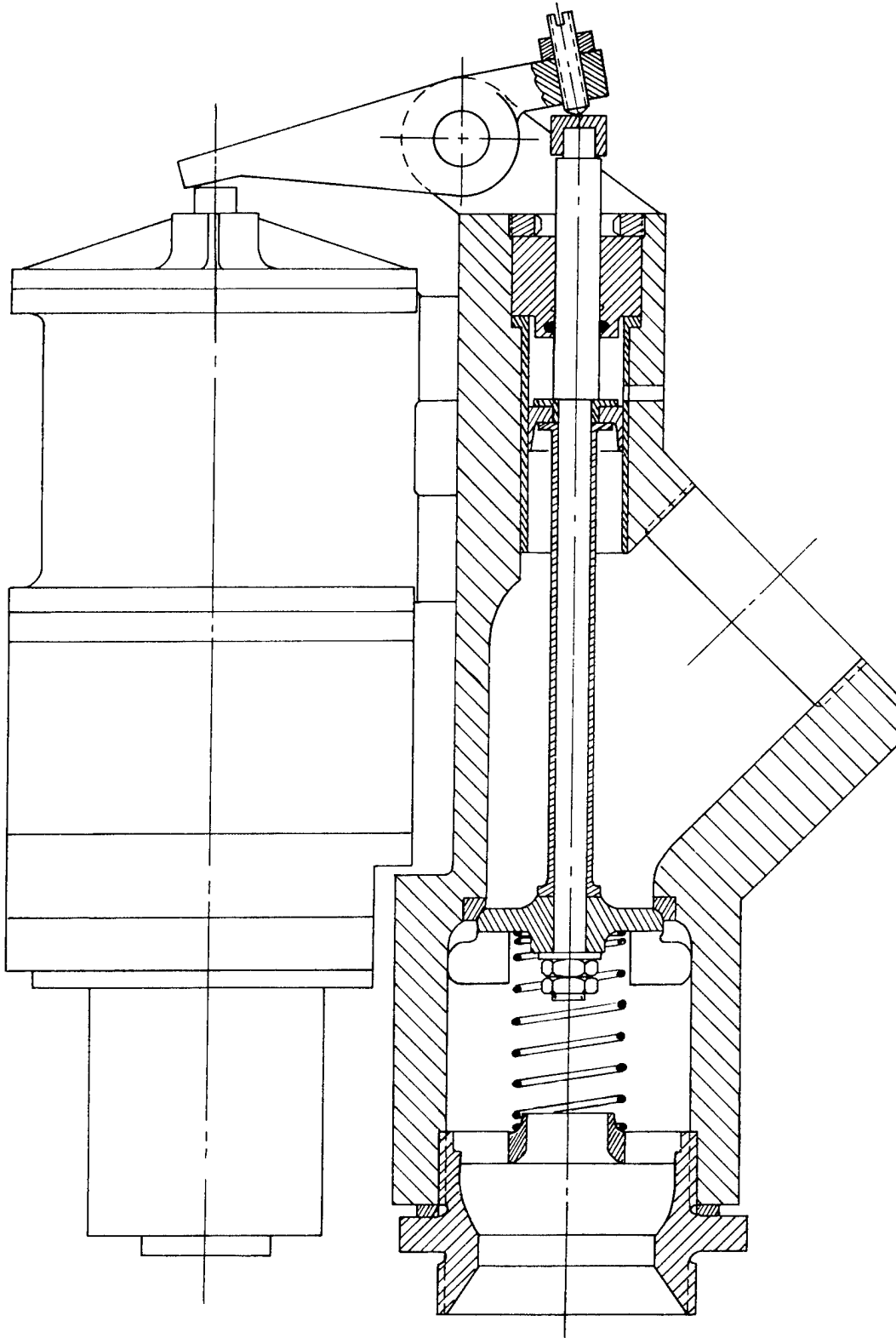

Fig. 7 - Improved Servo Valve

CONFIDENTIAL

CONFIDENTIAL

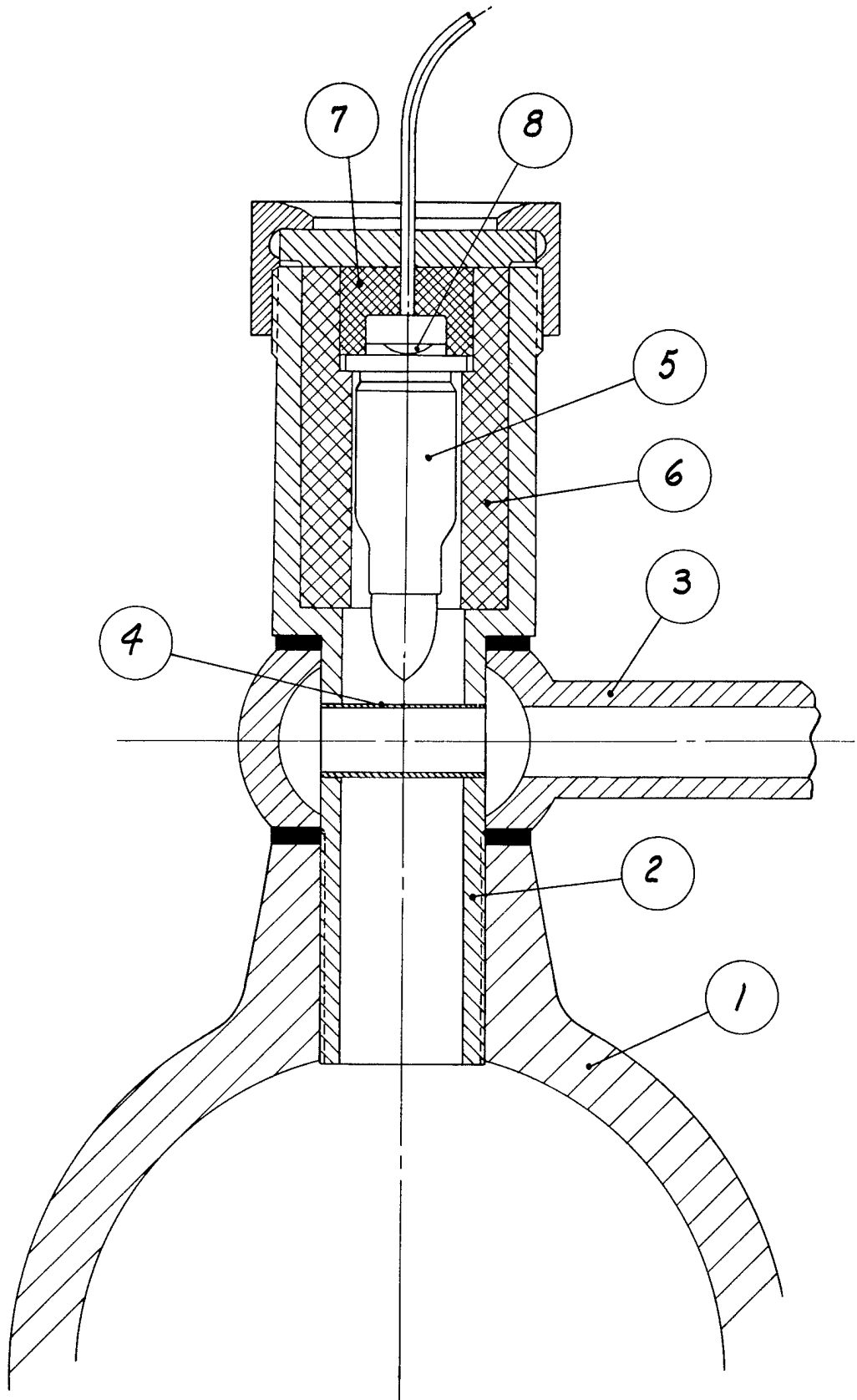

Fig. 8 - Cartridge Valve

CONFIDENTIAL

CONFIDENTIAL

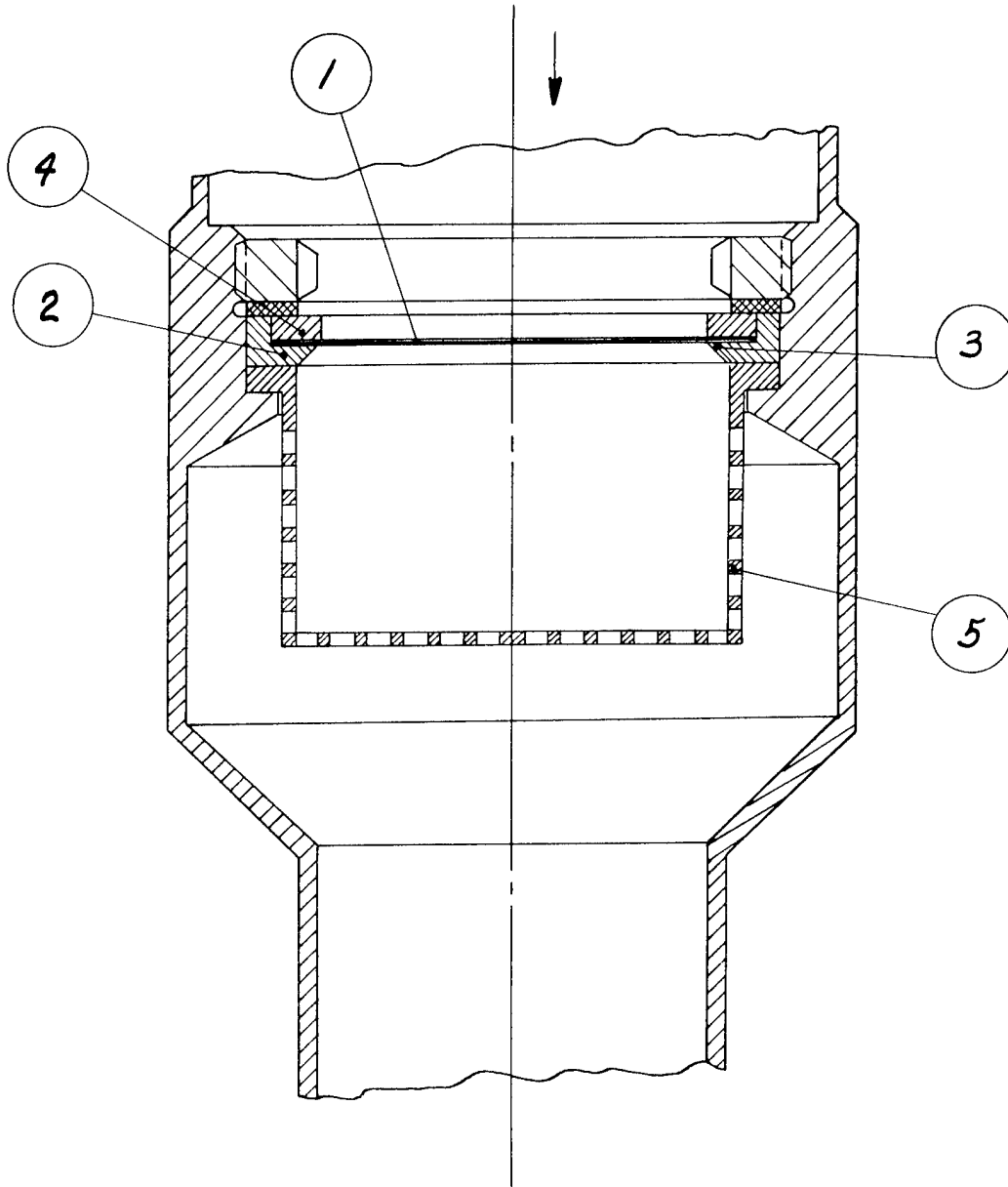

Fig. 9 - Diaphragm Valve

CONFIDENTIAL

CONFIDENTIAL

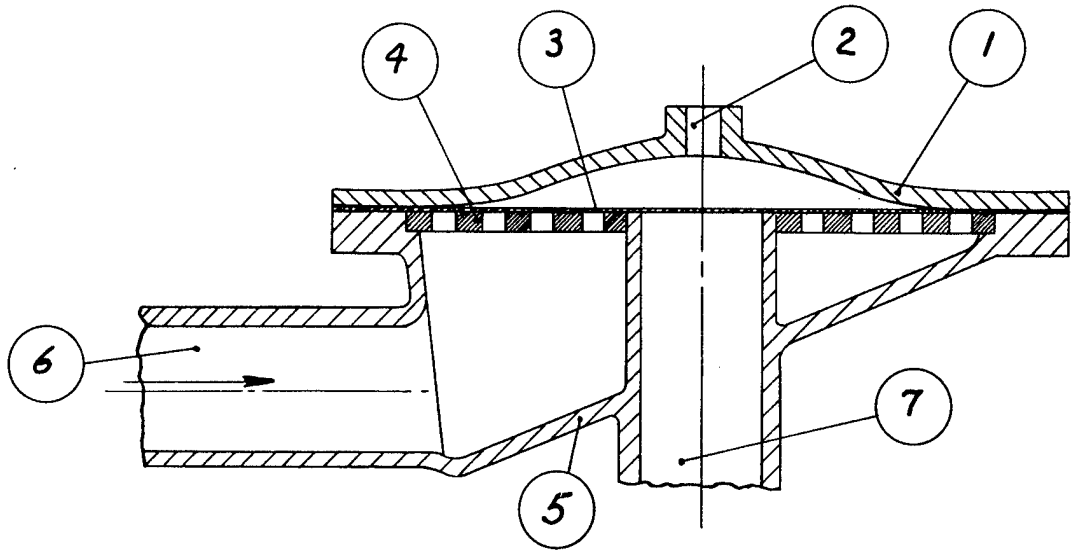

Fig. 10 - Diaphragm Valve

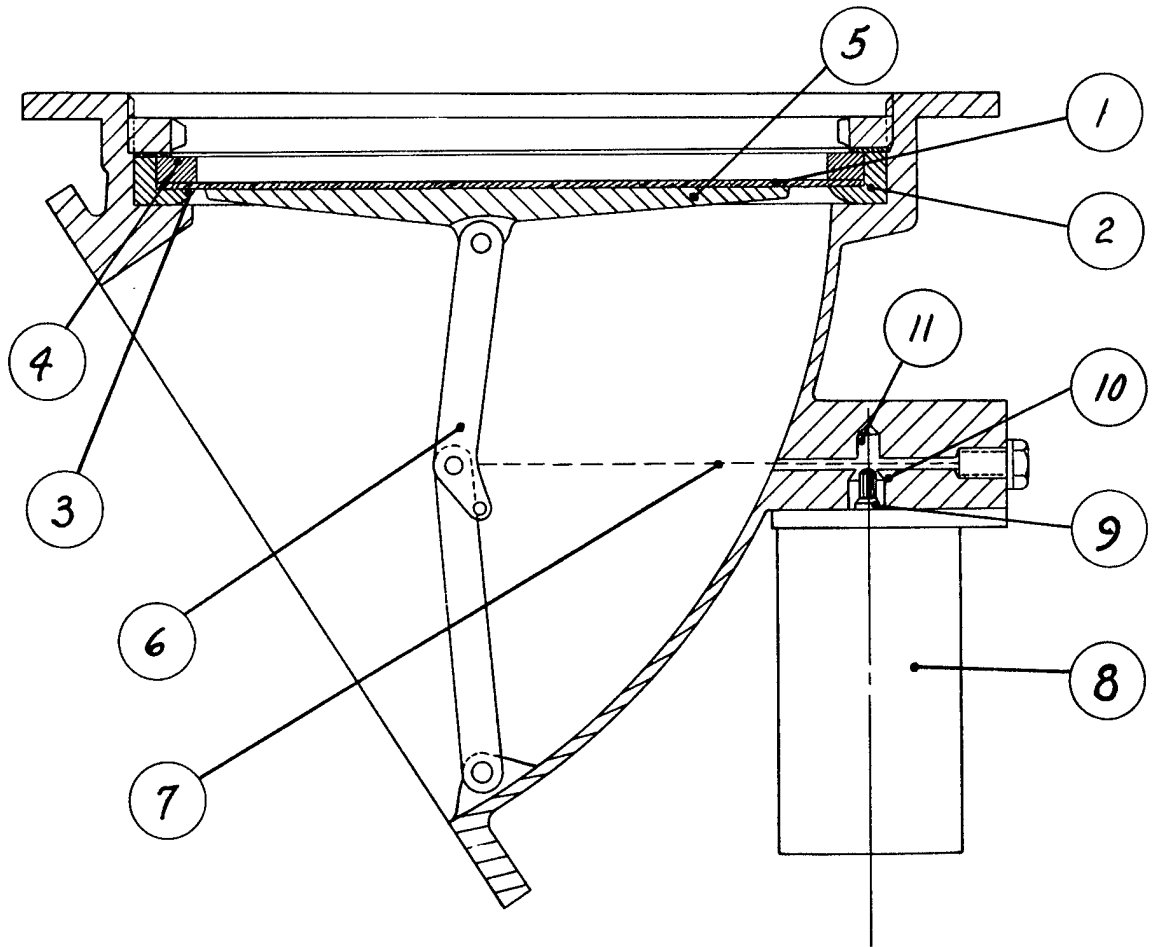
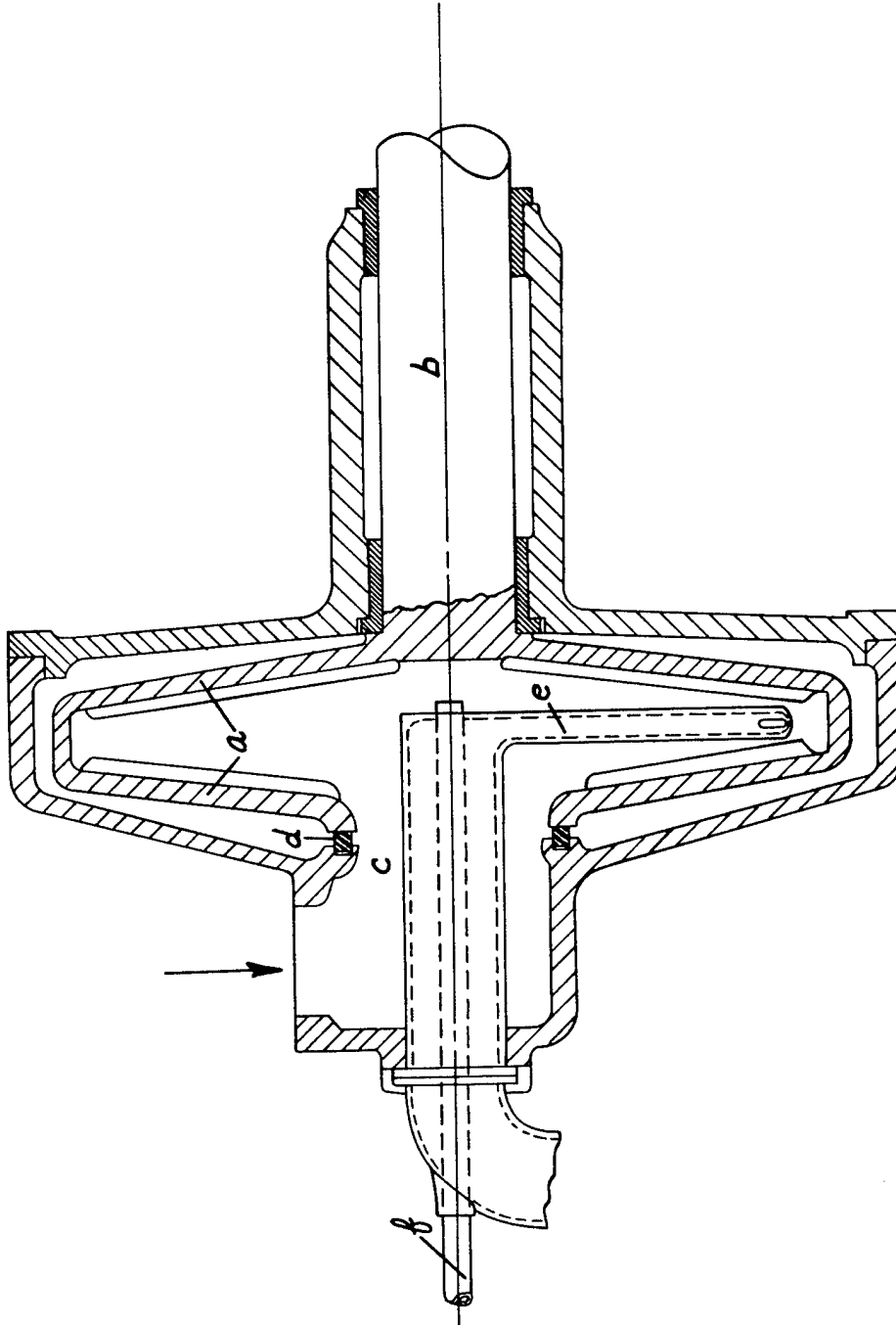

Fig. 11 - Diaphragm Valve

CONFIDENTIAL

CONFIDENTIAL



12 - Spoon Pump

CONFIDENTIAL

CONFIDENTIAL

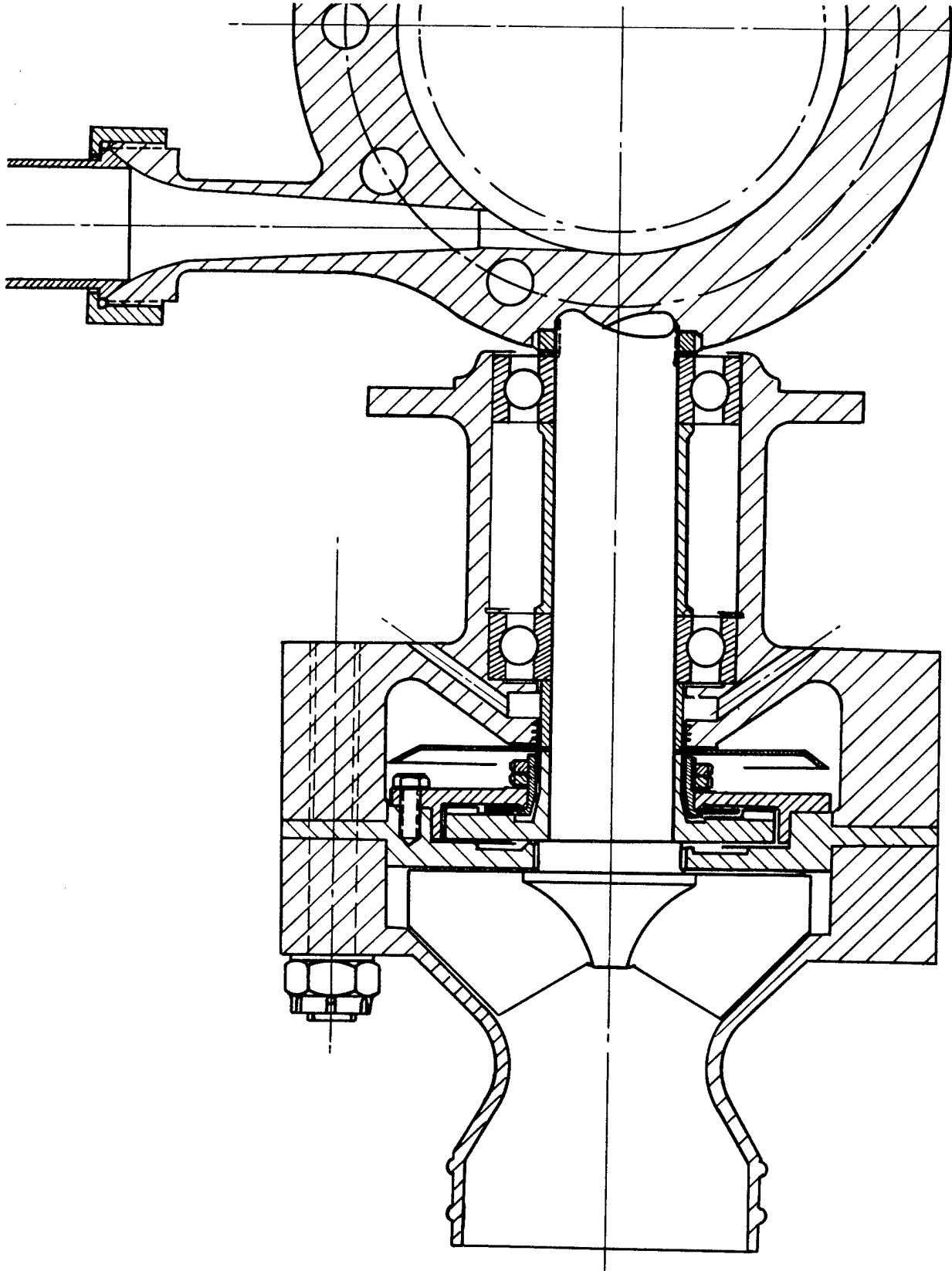

Fig. 13 - Mixed Flow Pump

CONFIDENTIAL

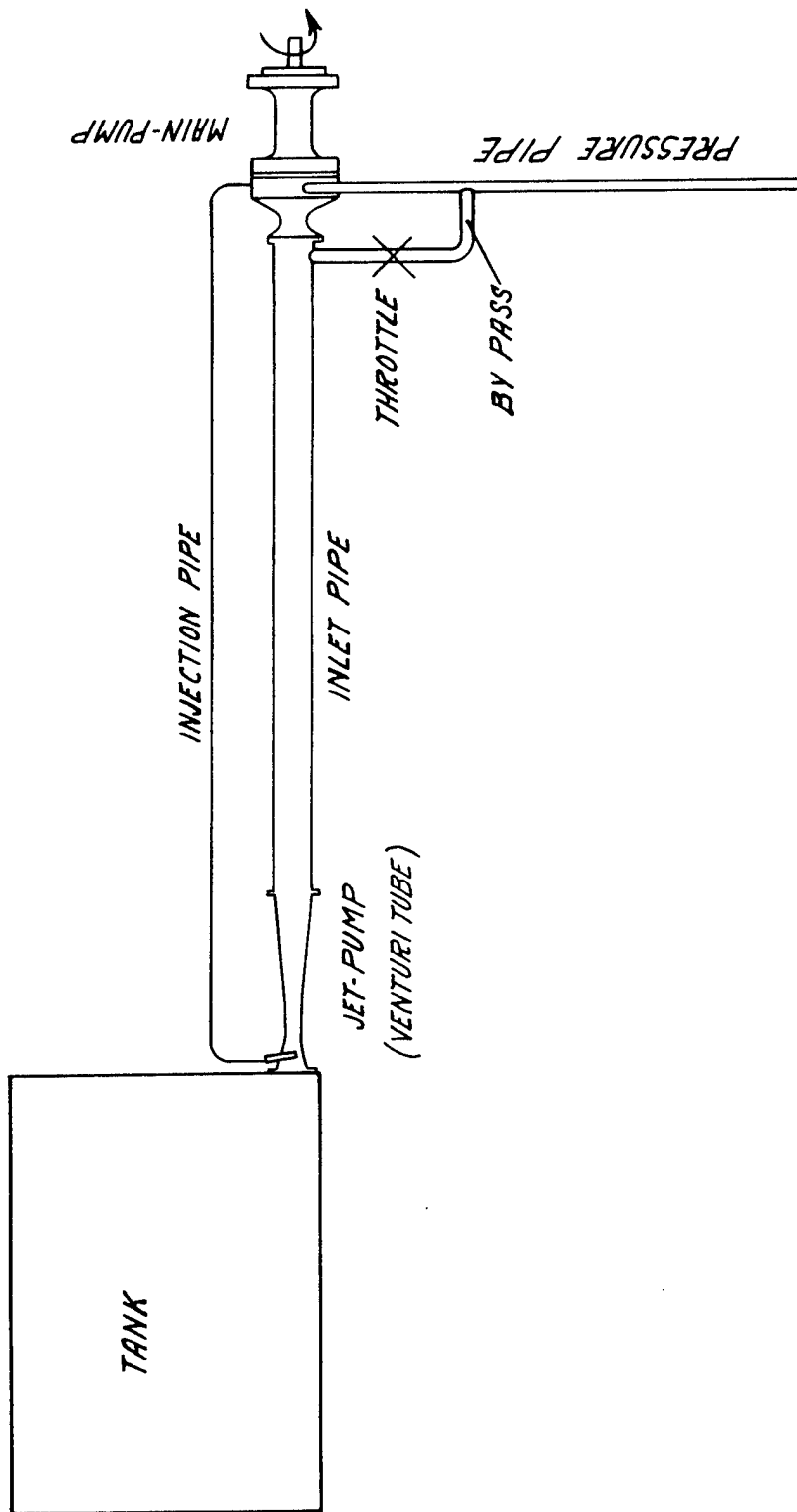

Fig. 14 - Jet-Pump Combination

CONFIDENTIAL

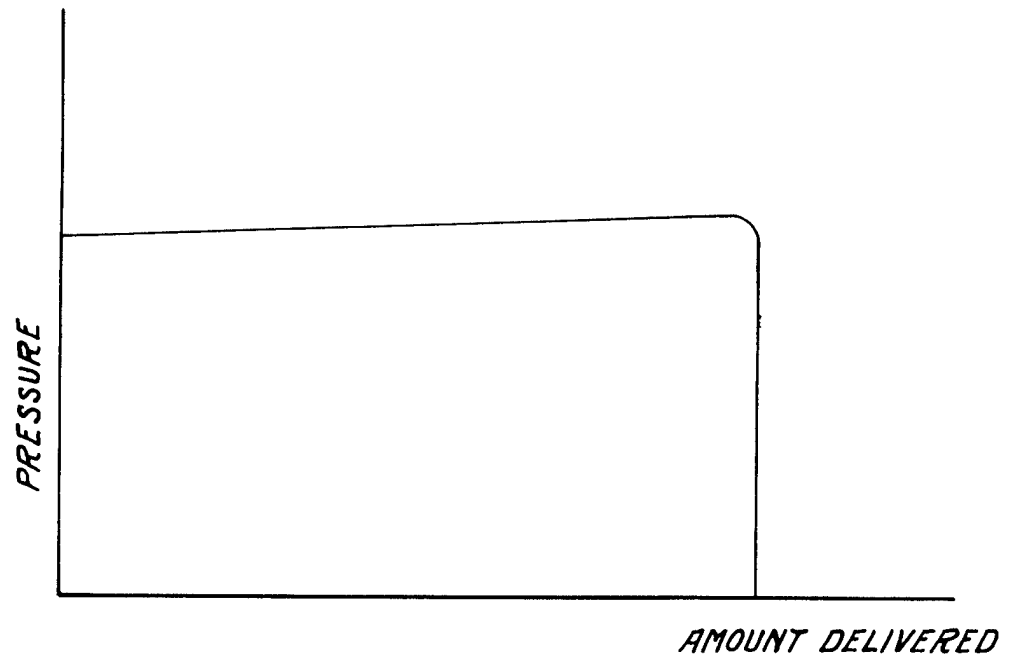

Fig. 15 - Pump-Performance Curve at Constant Speed

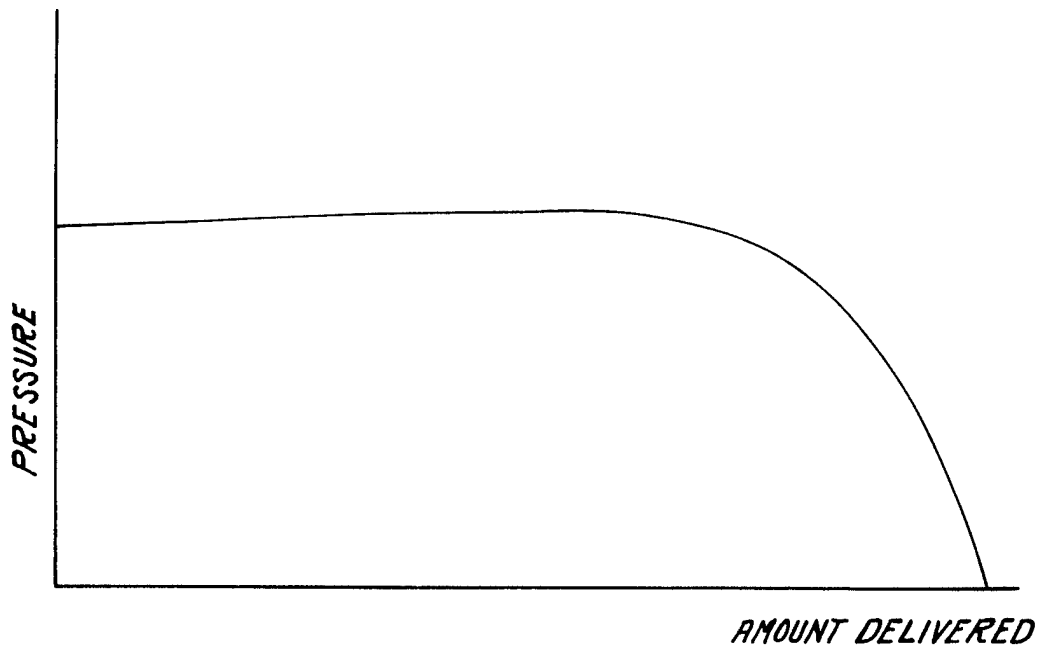

Fig. 16 - Pump-Performance Curve

CONFIDENTIAL

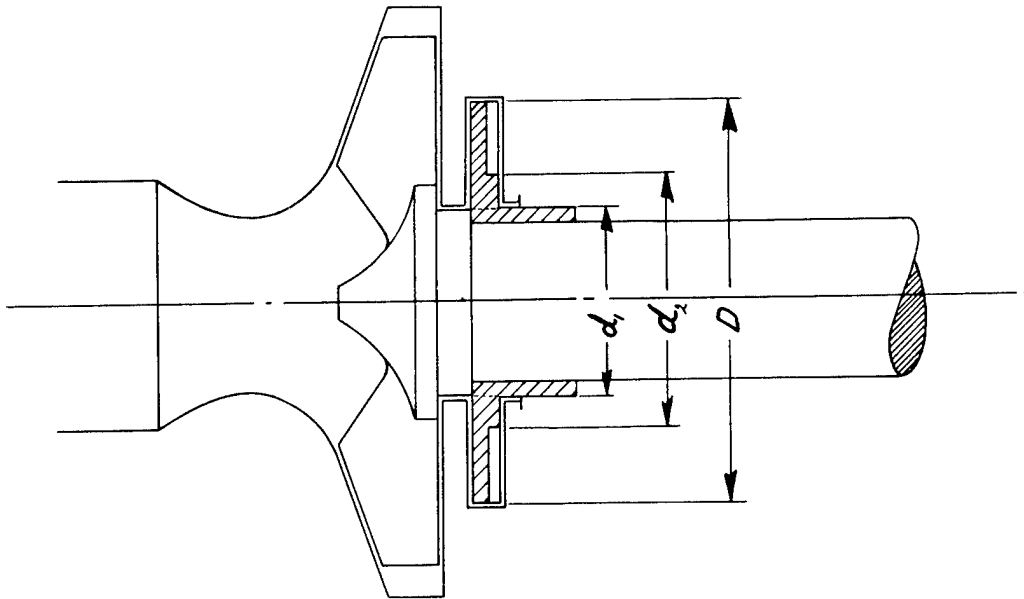

Fig. 17 - Pump and Return-Wheel Impeller

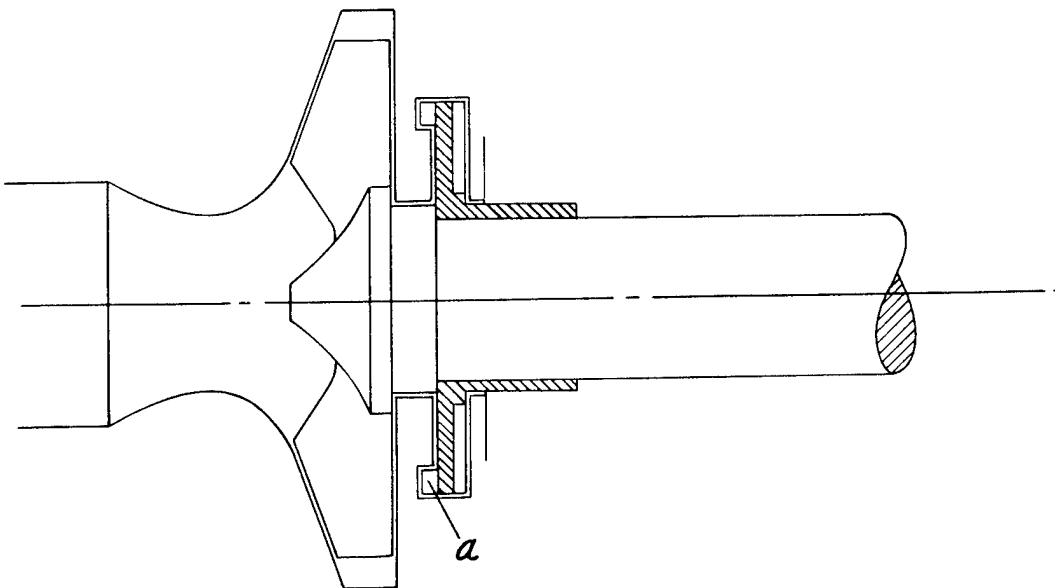

Fig. 18 - Return-Wheel Impeller With Flow-Balancing Blades

CONFIDENTIAL

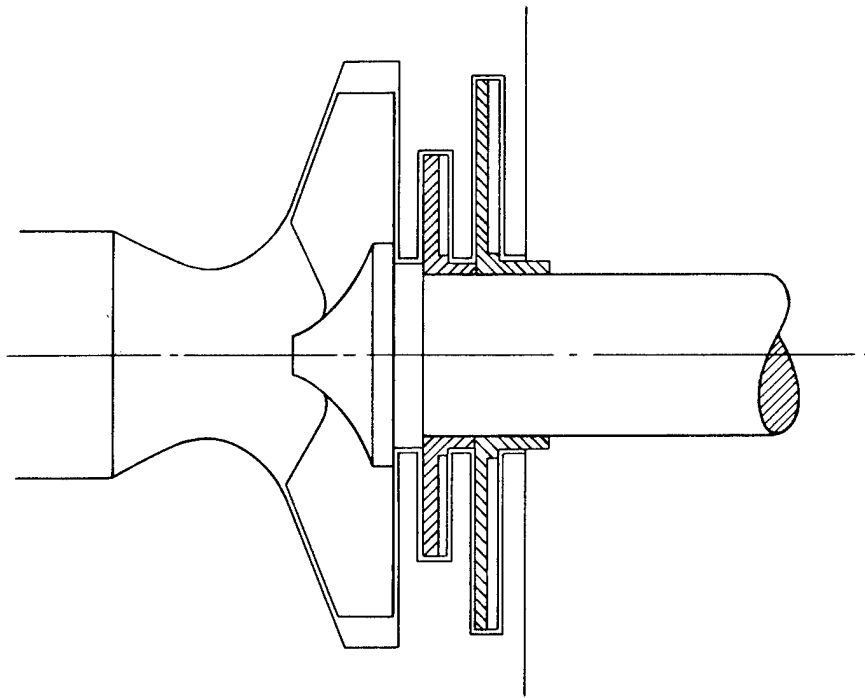

Fig. 19 - Dual Return-Wheel Impellers

CONFIDENTIAL

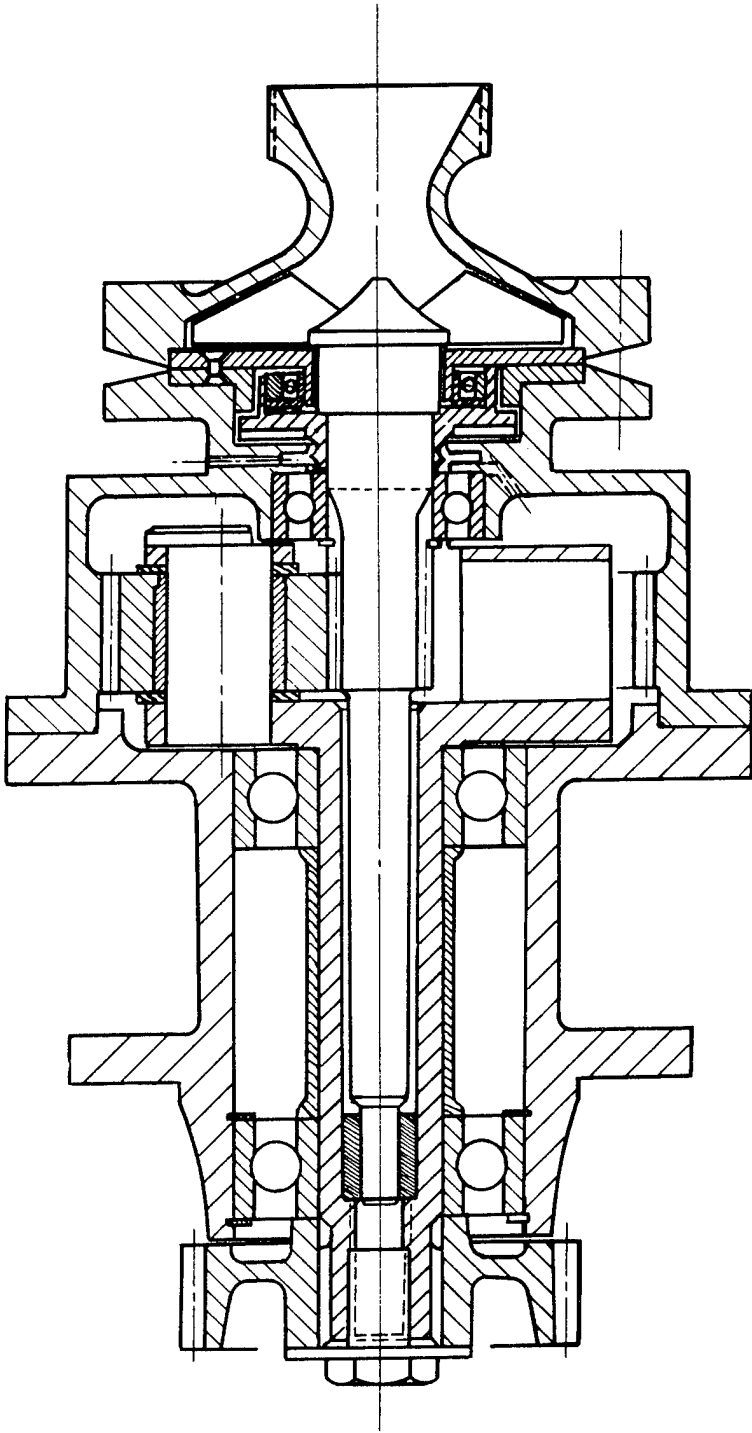

Fig. 20 - Pump With Friction Packing

CONFIDENTIAL

CONFIDENTIAL

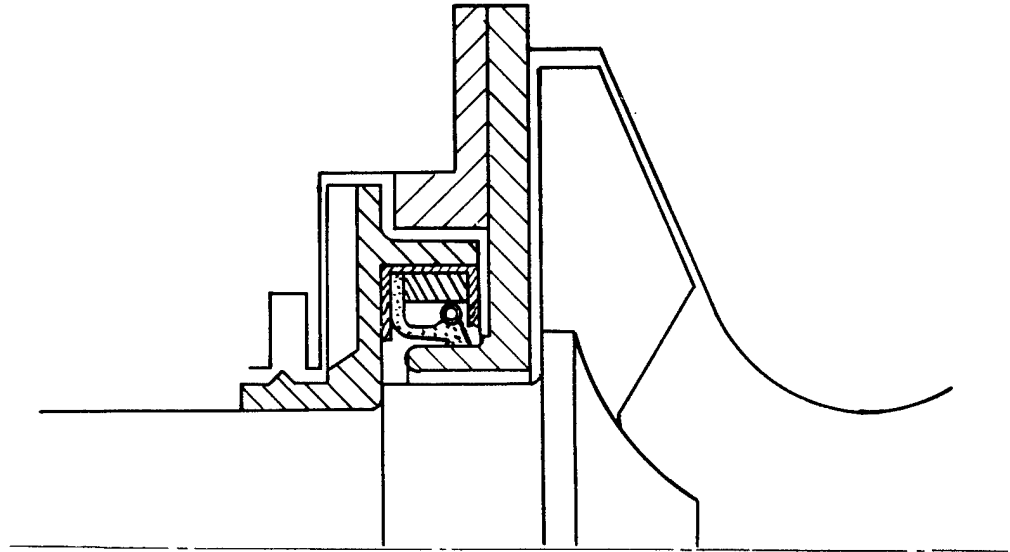

Fig. 21 - Disk-Cuff, Packing in Contact

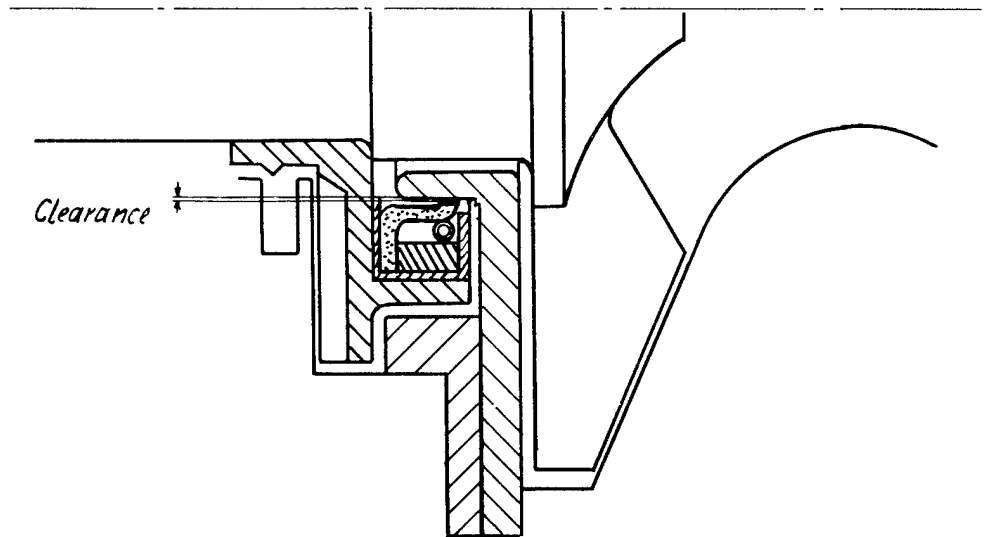

Fig. 22 - Disk-Cuff, Packing Disengaged

CONFIDENTIAL

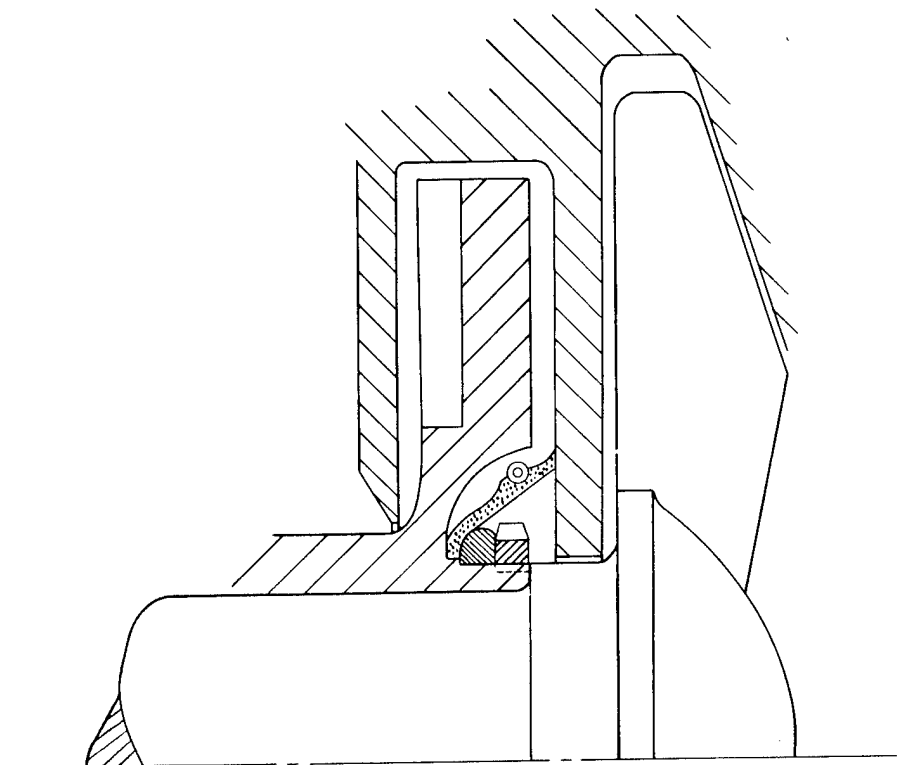

Fig. 23 - Axial-Cuff Packing

CONFIDENTIAL

CONFIDENTIAL

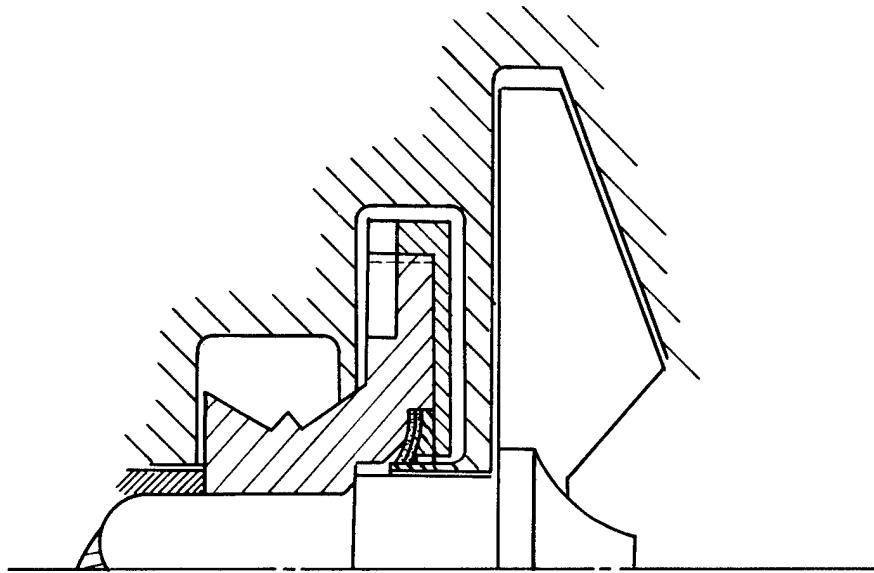

Fig. 24 - Lip Packing

CONFIDENTIAL

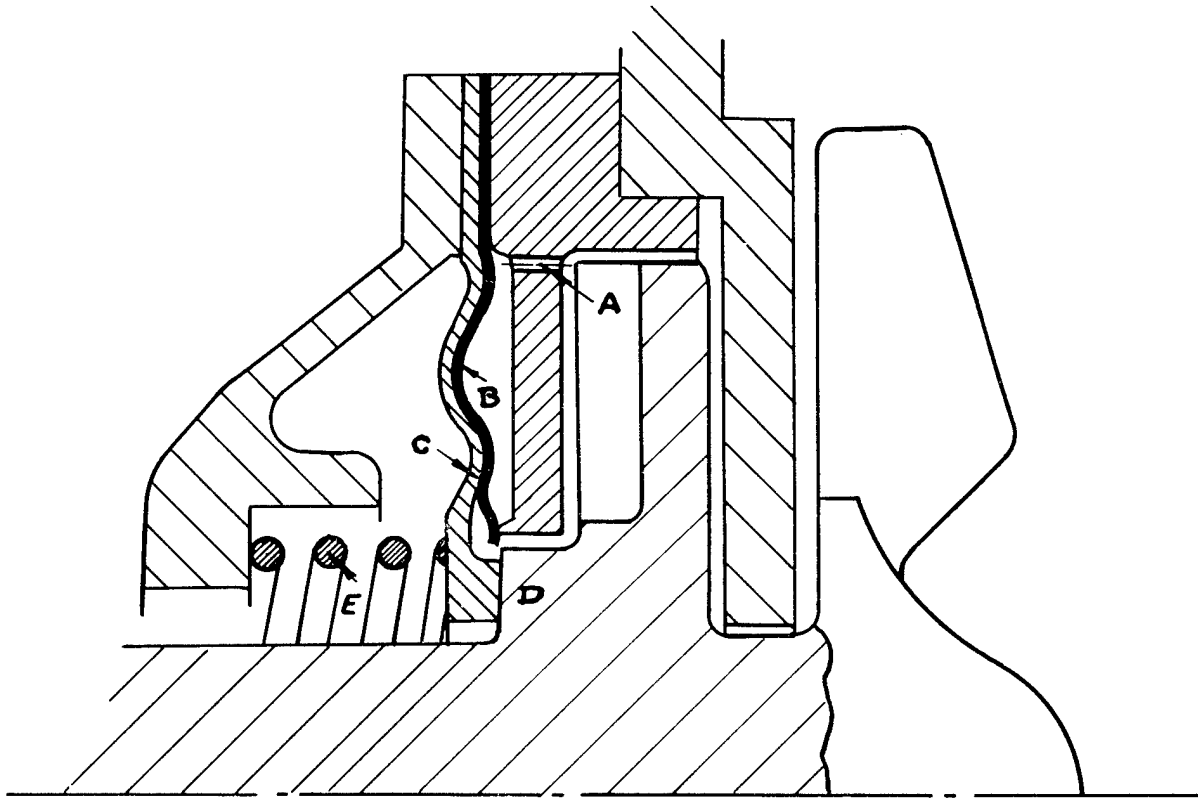

Fig. 25 - Diaphragm Sealing Ring

CONFIDENTIAL

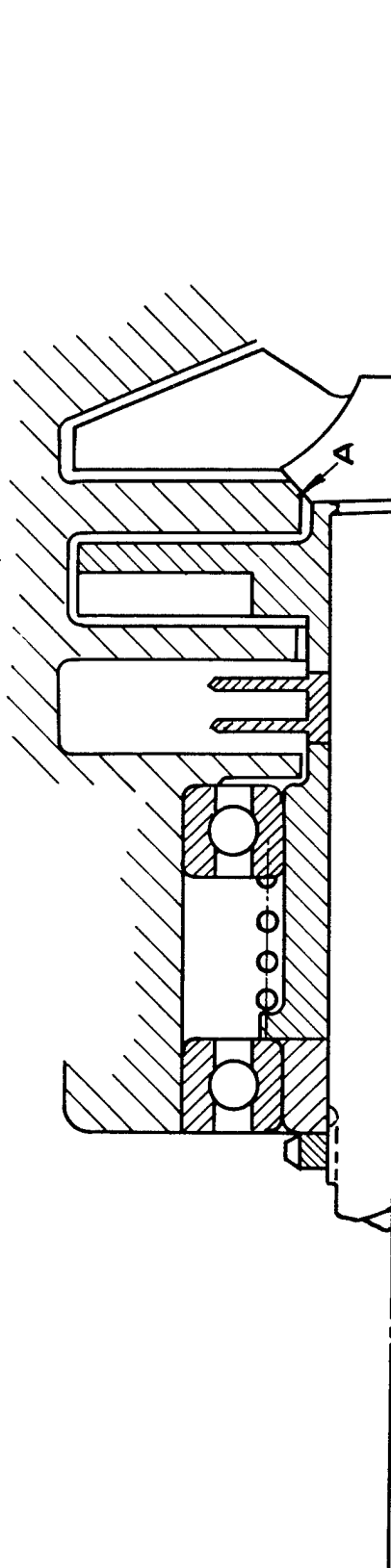

Fig. 26 - Axial Displacement Seal

CONFIDENTIAL

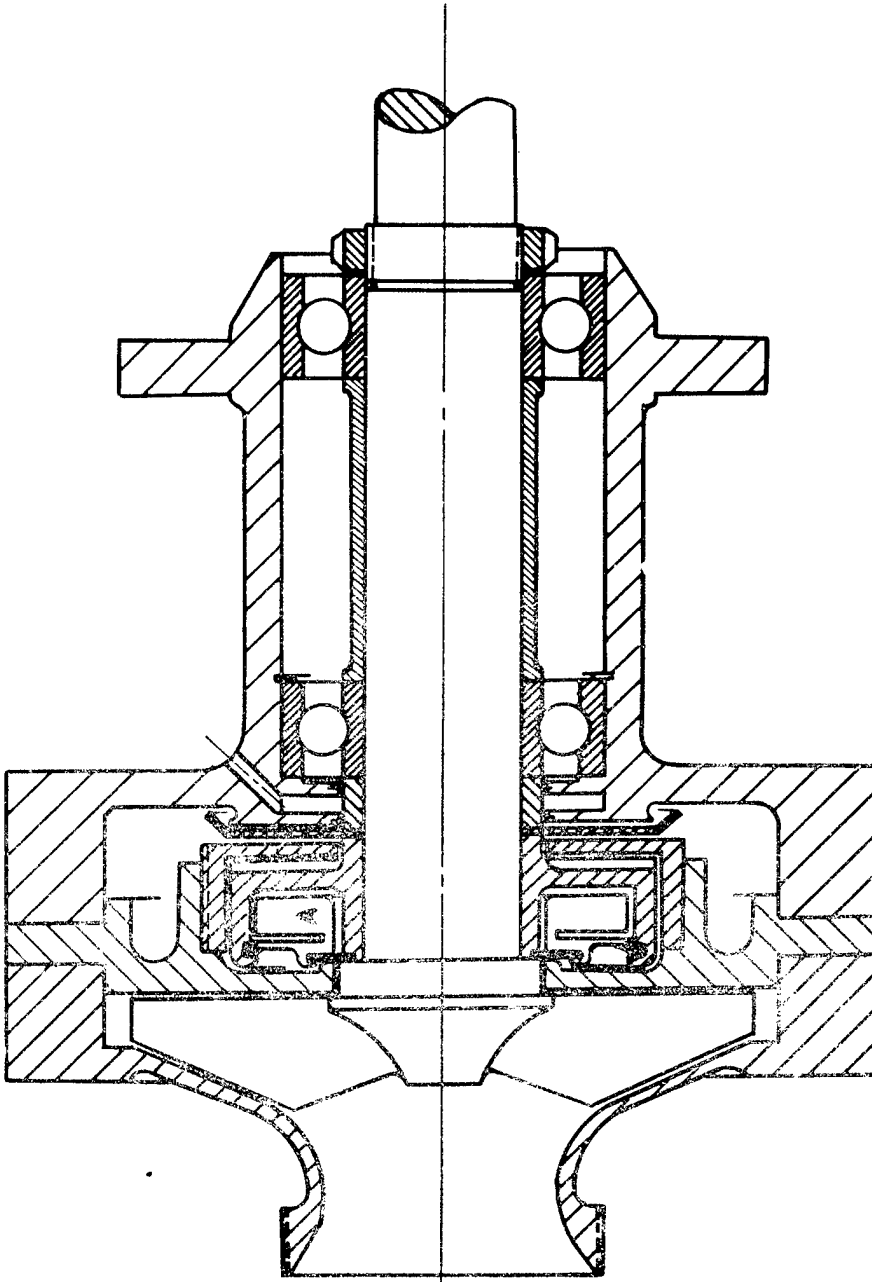

Fig. 27 - Centrifugal Return-Wheel Packing

CONFIDENTIAL

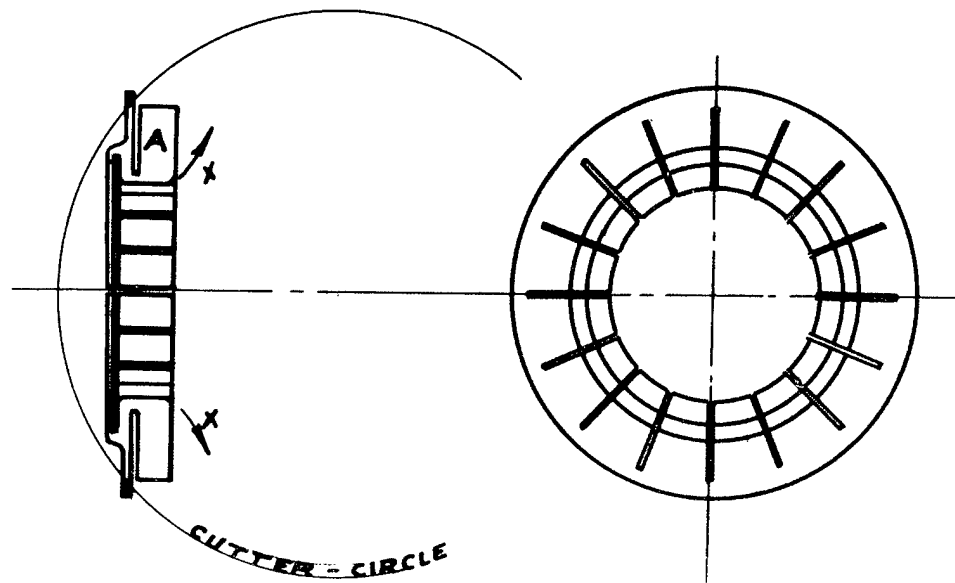

Fig. 28 - Centrifugal Seal Packing,
Side View

Fig. 29 - Centrifugal Seal Packing,
Top View

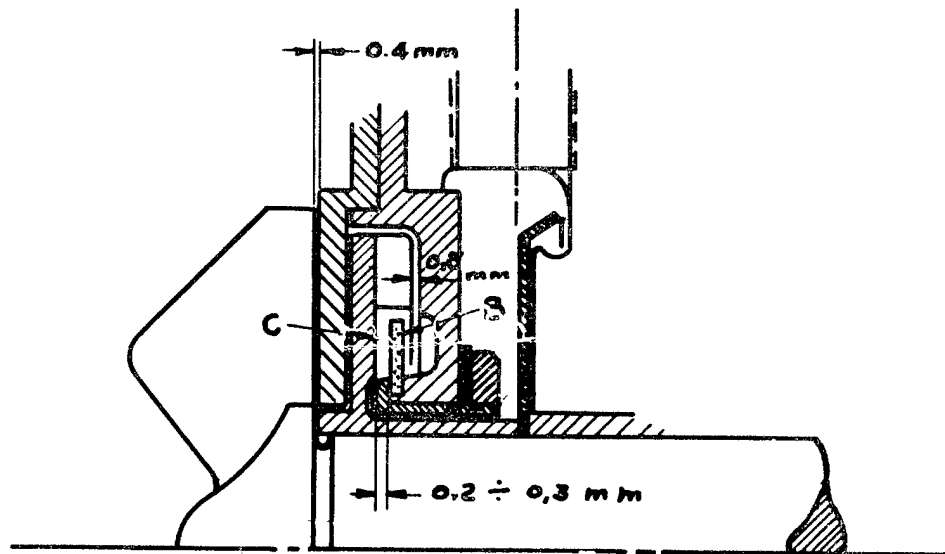

Fig. 30 - Differential Pressure Packing

CONFIDENTIAL

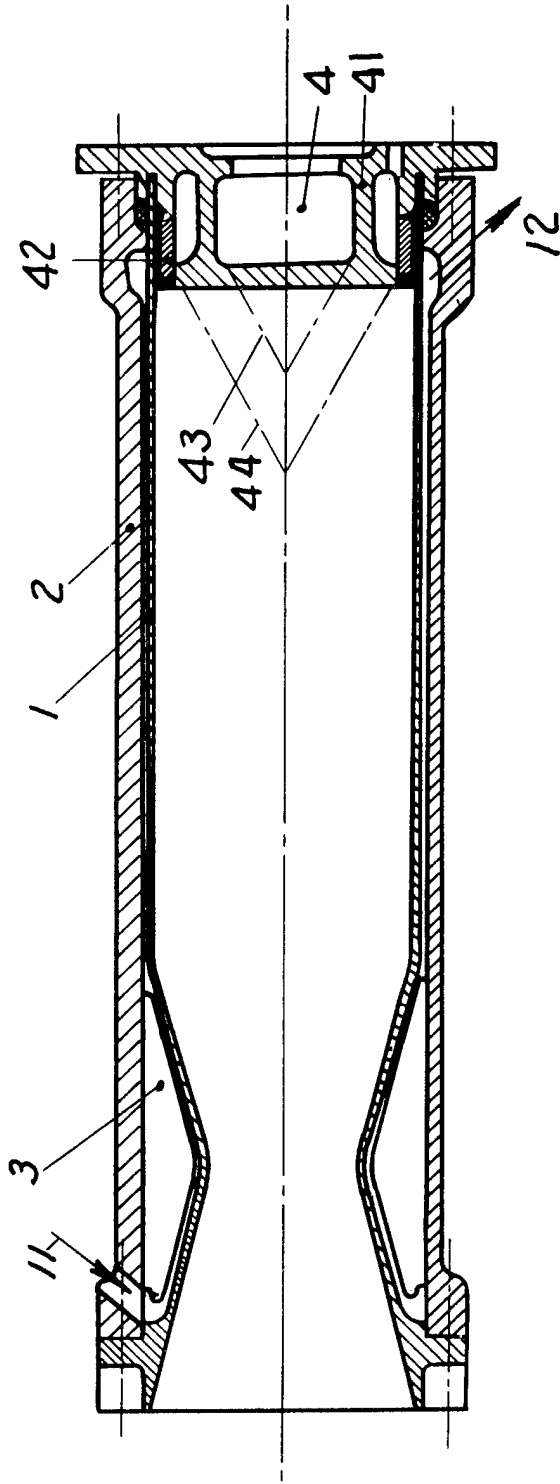
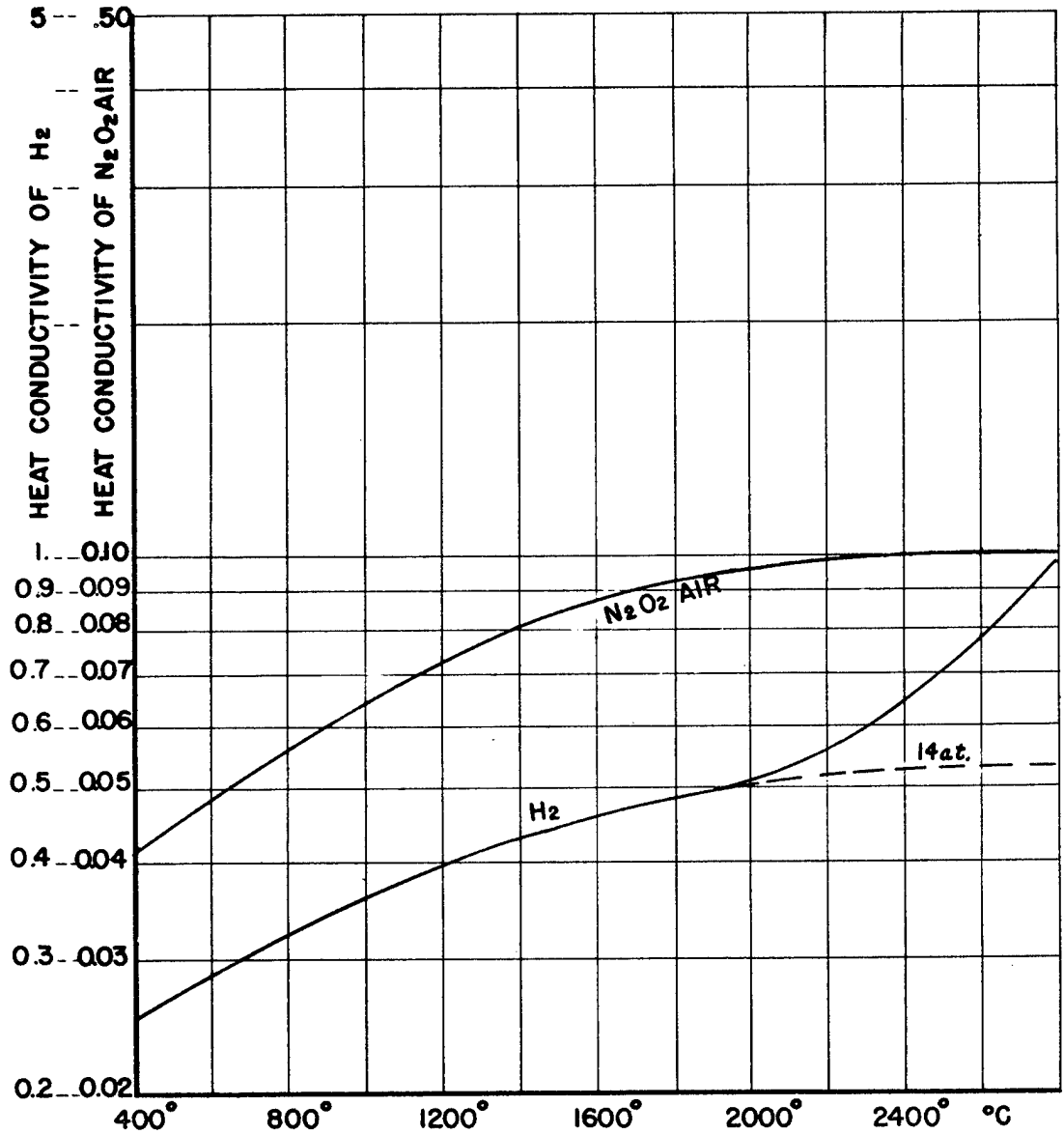

Fig. 31 - Rocket Combustion Chamber

CONFIDENTIAL



HEAT CONDUCTIVITY AT A PRESSURE OF 1 ATMOSPHERE

$$\lambda \text{ IN } \frac{\text{KILO CALORIES}}{\text{METER} \cdot \text{HR. } ^\circ\text{C}}$$

Fig. 32 - Heat Conductivity Diagram

CONFIDENTIAL

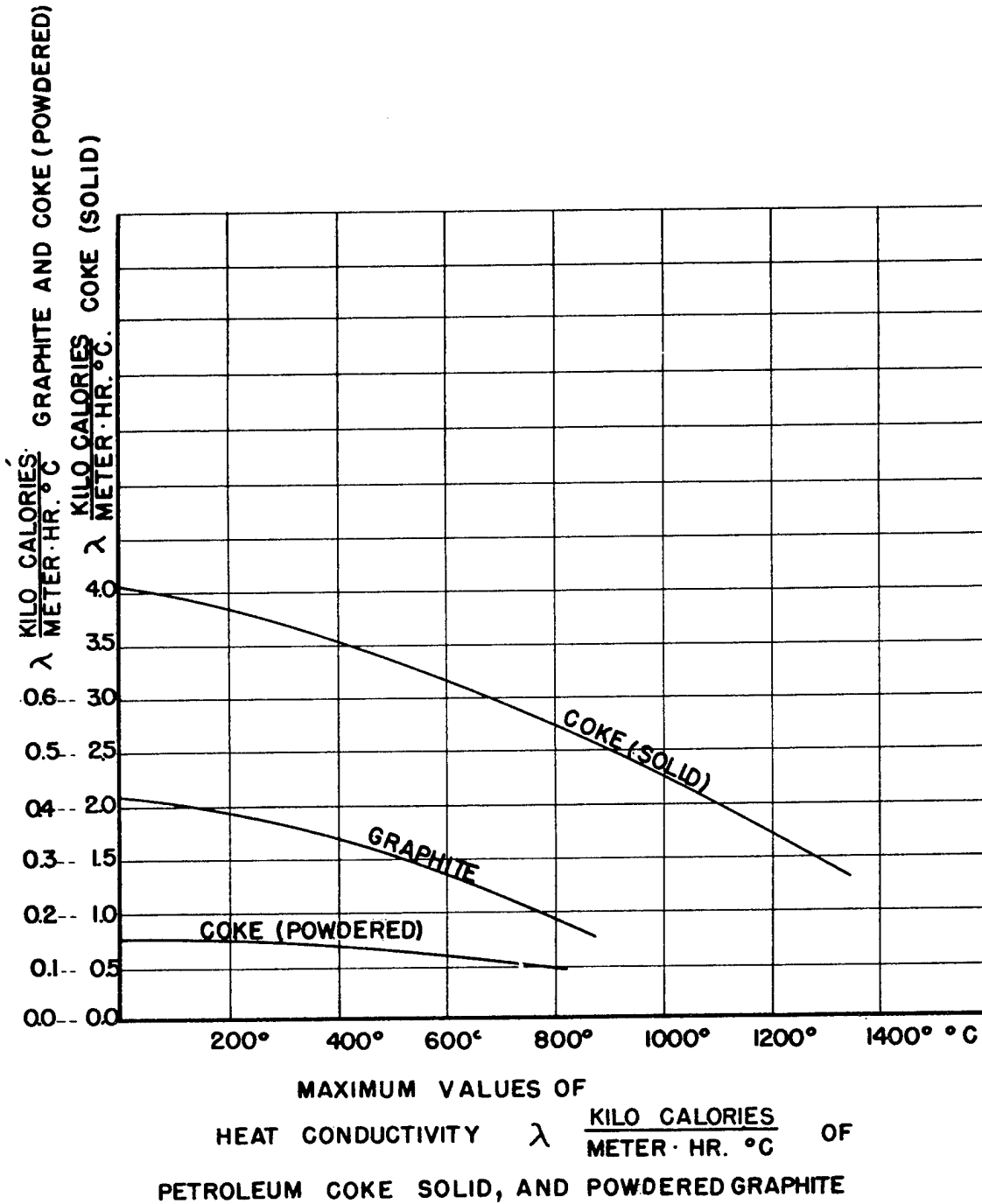

MAXIMUM VALUES OF
HEAT CONDUCTIVITY λ $\frac{\text{KILO CALORIES}}{\text{METER} \cdot \text{HR.} \cdot \text{°C}}$ OF
PETROLEUM COKE SOLID, AND POWDERED GRAPHITE

Fig. 33 - Heat Conductivity Diagram

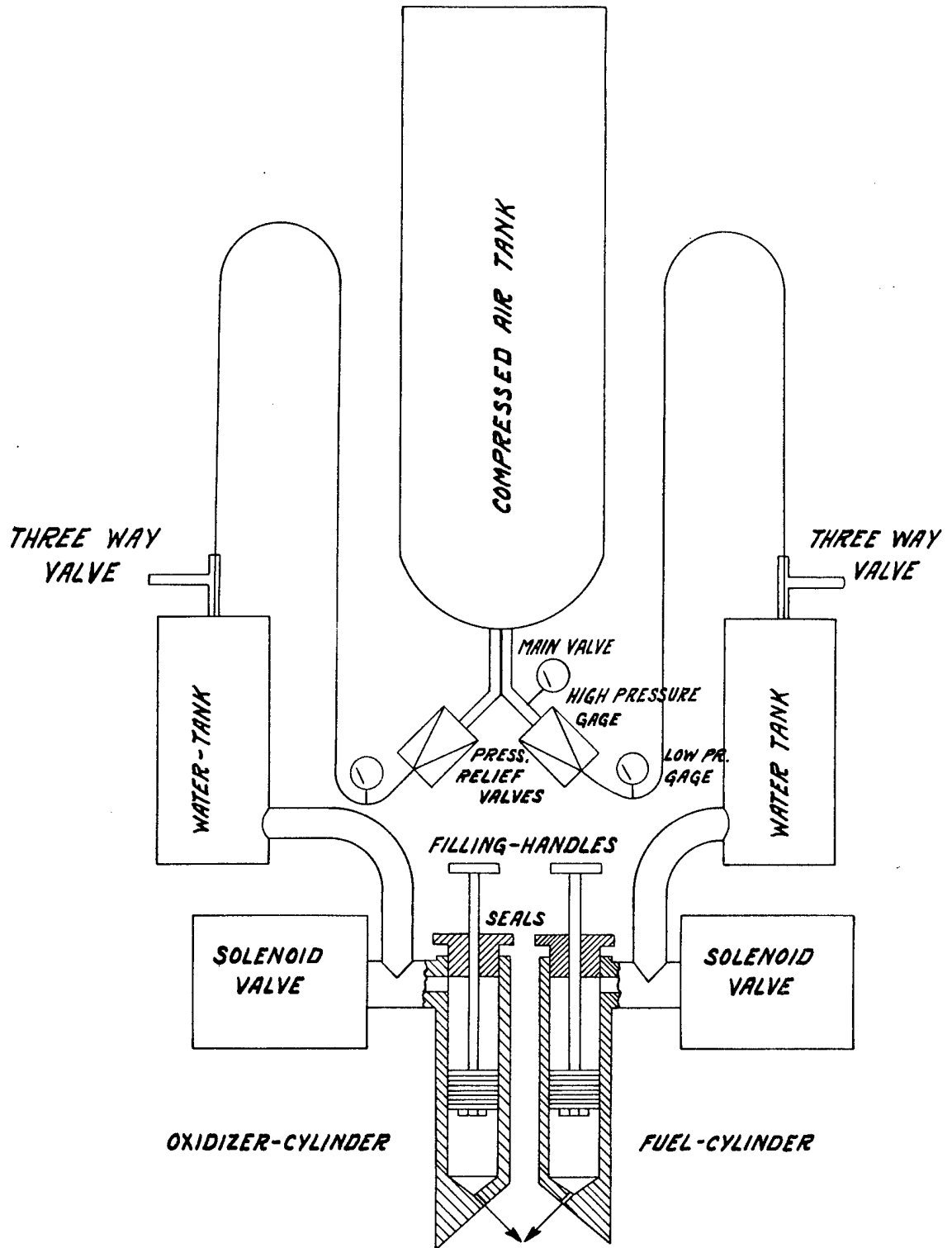

Fig. 34 - Test Installation for Rocket Propellants

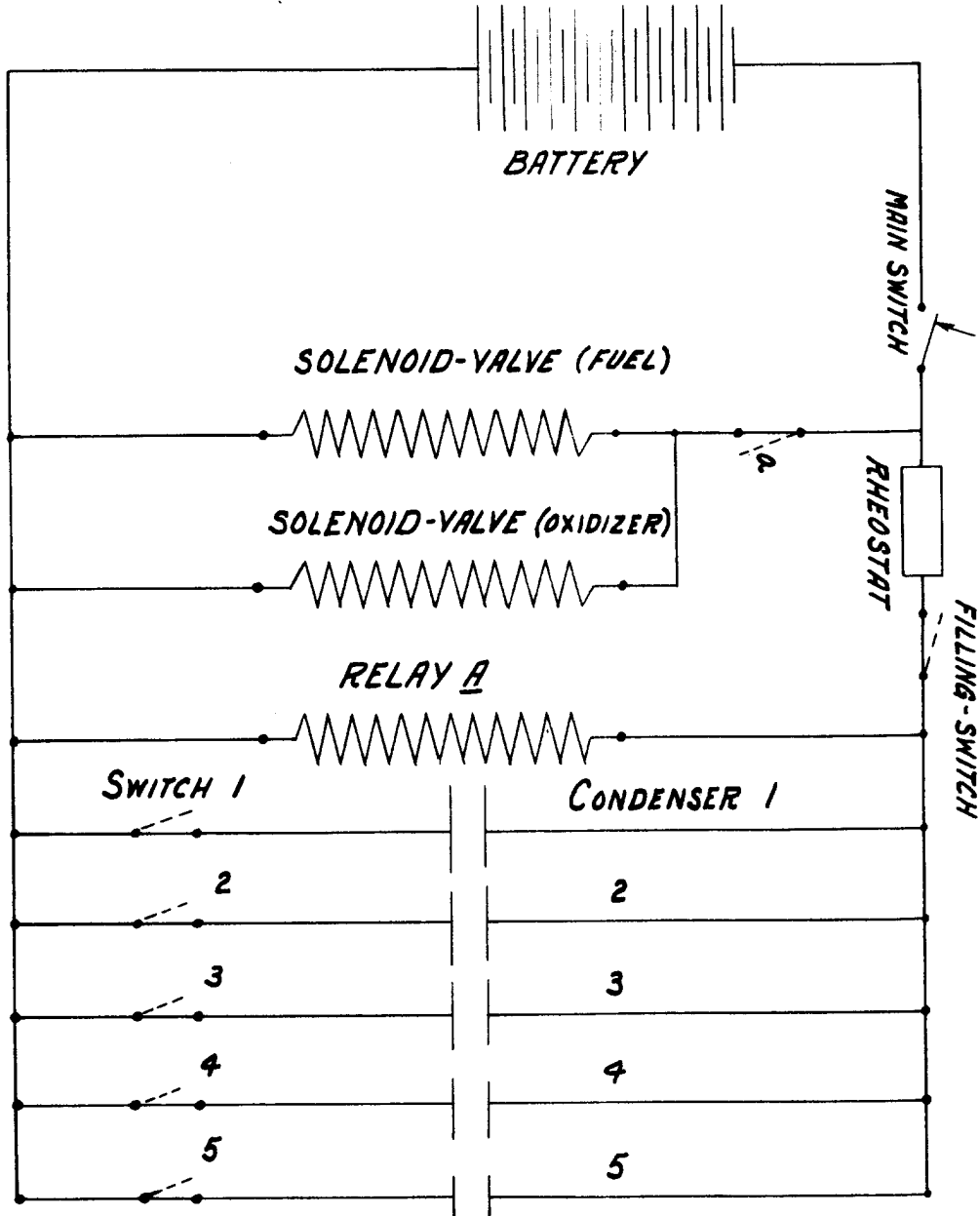
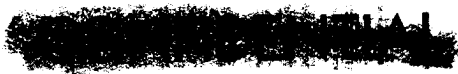

Fig. 35 - Electrical Wiring Chart



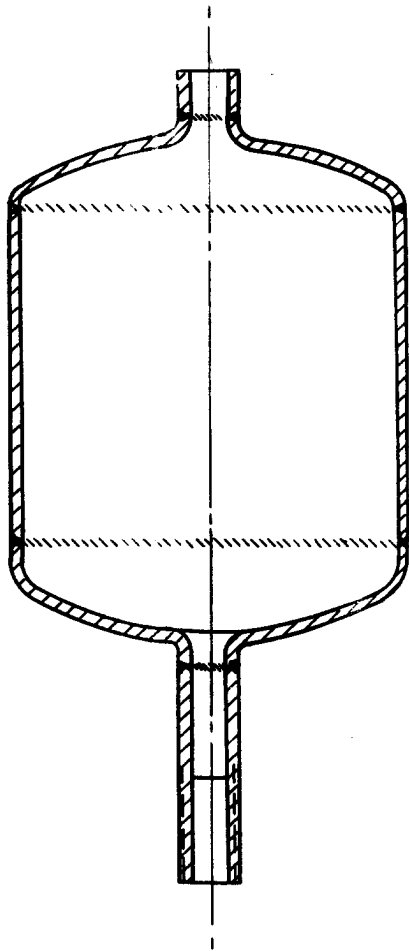

Fig. 36 - Water Tank

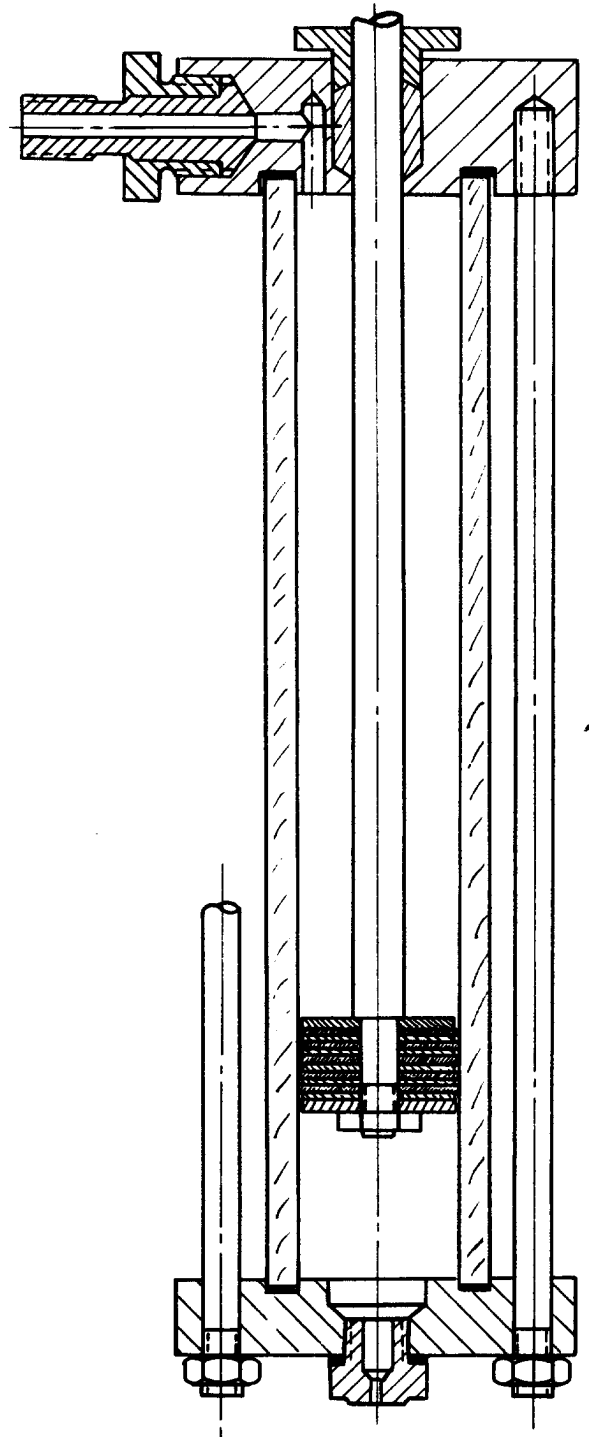

Fig. 37 - Test Cylinder

