

CECW-EP

DEPARTMENT OF THE ARMY  
US Army Corps of Engineers  
Washington, DC 20314-1000

EM 1110-1-1002

Engineer Manual  
No. 1110-1-1002

14 September 1990

Engineering and Design  
SURVEY MARKERS AND MONUMENTATION

1. Purpose. This manual establishes criteria and presents guidance for monumentation during various stages of civil and military projects.
2. Applicability. This manual applies to all field operating activities having civil works and military responsibilities.
3. Accompanying Guide Specification. To facilitate contracting for monumentation, accompanying guide specifications have also been developed. This manual is designed to be used in conjunction with the accompanying guide specifications as an aid in contracting for monumentation.

FOR THE COMMANDER:



ALBERT J. GENETTI, JR.  
Colonel, Corps of Engineers  
Chief of Staff

20020603 128

CECW-EP  Engineer Manual 1110-1-1002	Department of the Army U.S. Army Corps of Engineers Washington, DC 20314-1000	EM 1110-1-1002  14 September 1990
	Engineering and Design  SURVEY MARKERS AND MONUMENTATION	
	<b>Distribution Restriction Statement</b> Approved for public release; distribution is unlimited.	

CECW-EP

DEPARTMENT OF THE ARMY  
US Army Corps of Engineers  
Washington, DC 20314-1000

EM 1110-1-1002

Engineer Manual  
No. 1110-1-1002

14 September 1990

Engineering and Design  
SURVEY MARKERS AND MONUMENTATION

Table of Contents

<u>Subject</u>	<u>Paragraph</u>	<u>Page</u>
CHAPTER 1. INTRODUCTION		
Purpose	1-1	1-1
Applicability	1-2	1-1
Reference	1-3	1-1
Background	1-4	1-1
Scope of Manual	1-5	1-1
Development of a Survey		
Monumentation Comprehensive Plan	1-6	1-1
Permanent Monuments	1-7	1-2
Temporary Markers	1-8	1-2
Public Relations	1-9	1-2
Metrics	1-10	1-2
Brand Names	1-11	1-2
CHAPTER 2. SITE SELECTION		
General	2-1	2-1
Security	2-2	2-1
Utility	2-3	2-1
Stability	2-4	2-2
Corrosive Environment	2-5	2-4
Safety	2-6	2-5
Satellite Visibility	2-7	2-6
Cost Comparison	2-8	2-7
CHAPTER 3. VERTICAL CONTROL - BENCH MARKS		
Selection of Monument Type Based on		
Local Site Conditions	3-1	3-1
Construction and Installation		
Procedures	3-2	3-9
Naming Vertical Control Monuments	3-3	3-17
Marks of Other Organizations	3-4	3-19
Witness Posts and Signs	3-5	3-20

<u>Subject</u>	<u>Paragraph</u>	<u>Page</u>
CHAPTER 4. HORIZONTAL CONTROL MONUMENTS		
Selection of Monument Type Based on Local Site Conditions	4-1	4-1
Construction and Installation Procedures	4-2	4-1
Naming Horizontal Control Monuments	4-3	4-2
Reference and Azimuth Marks	4-4	4-7
Three-Dimensional Monuments	4-5	4-9
Marks of Other Organizations	4-6	4-9
Witness Posts	4-7	4-9
CHAPTER 5. BOUNDARY MONUMENTS		
Installation of Boundary Monumentation	5-1	5-1
Selection of Monument Type Based on Local Site Conditions	5-2	5-1
Construction and Installation Procedures	5-3	5-2
Naming Boundary Monuments	5-4	5-2
Reference Monuments	5-5	5-2
Witness Trees and Corners	5-6	5-3
Boundary Marker Sign	5-7	5-3
CHAPTER 6. DOCUMENTATION		
Monument/Marker Documentation	6-1	6-1

## CHAPTER 1

### INTRODUCTION

1-1. Purpose. This manual establishes criteria and presents guidance on monumentation installation and documentation for all types of surveys required during the various stages of civil and military projects. The manual is intended to be a guide; however, when the standard Corps monuments are used, they shall be selected and constructed as defined in this manual.

1-2. Applicability. This manual applies to all Corps of Engineers field operating activities.

1-3. Reference. Specifications on naming criteria, standard installation procedures, and accuracy classifications were adopted in part from the National Geodetic Survey (NGS).

1-4. Background. Stable monuments are required for both horizontal and vertical control. Monuments and their stability are integral parts of the accuracy of each survey project. Inaccurate survey control monumentation can contribute to costly errors in all phases of project design and development. Therefore, the purpose of this manual is to establish criteria and present guidance that will insure stable monumentation throughout design, construction, and subsequent maintenance of each Corps project.

1-5. Scope of Manual. This manual provides naming criteria, standard installation procedures, and associated surveying accuracies for horizontal and vertical control and boundary survey markers and monumentation for standard Corps monuments. It should be used as a guide in planning surveys and marker and/or monument installation and identification. The type of marker and/or monument selected for each survey should be tailored to meet the minimum accuracy requirements for the individual project. However, selection should be done within the stated criteria where feasible and practicable, using the guidance provided herein. The accuracy classification of each survey monument is dependent upon the site foundation conditions and the type of monument installation used. All standard Corps monuments as defined herein shall be installed in accordance with this manual. The term "marks" shall be used throughout this manual when referring to both permanent monuments and temporary markers. The term "bench mark" refers to a mark whose elevation is known. Monuments and markers are further defined in paragraphs 1-7 and 1-8.

1-6. Development of a Survey Monumentation Comprehensive Plan. In the earliest phase of project development a survey monumentation plan shall be developed. This plan shall consider monuments required for the life of each project, i.e., planning, acquisition, design, construction, operation, and maintenance. This plan will eliminate surveys performed using different survey

control accuracies and provide a common base for all surveys for each project.

1-7. Permanent Monuments. Permanent monuments shall be defined as monuments that are set in relatively stable material or in a structure for the purpose of preserving the location of either a horizontal control station, the elevation of a point above an adopted datum (bench mark), or the location and/or elevation of any point of special significance when its preservation is required permanently or for longer than 2 years. All monument types shown in the tables in this engineering manual are considered to be permanent.

1-8. Temporary Markers. Temporary markers shall be defined in the same manner as permanent monuments except that preservation is only required for a period of 2 years or less. Temporary markers shall consist of a 1- by 2-inch or larger wooden hub with adjacent guard stakes, a copper nail and washer, P-K nail, or other temporary spike set in relatively stable in situ material. Markers established on structures less than 5 years old shall also be considered temporary.

1-9. Public Relations. The purpose of the Federal government and its contractors is to serve the public. To fulfill this charge, it is imperative to gain the understanding and maintain the goodwill of the public. With these considerations in mind, always obtain the permission of the landowner when setting marks on private property. Responsible officials must also be consulted when a prospective site is located on public or corporate land. If approached in a polite and tactful manner, a hesitant individual may often be persuaded to allow installation of a mark at the desired site. Most citizens may be influenced to take personal interest in having a monument carrying the U.S. Army Corps of Engineers (USACE) designation on their property. To help encourage an individual to cooperate, explain the purpose of these marks, the need for the stability and durability of marks, and the expense involved in replacing them. Under no circumstances shall a mark be installed on an unwilling property owner's land that could provoke hostility toward the Federal government and its contractors.

1-10. Metrics. The use of both the metric and English systems of measurement in this manual is predicated on the common use of both systems by the surveying and mapping professions; i.e., water depths are usually measured in feet, and distances are usually measured in meters as determined by the equipment manufacturers.

1-11. Brand Names. The citation in this report of brand names of commercially available products does not constitute official endorsement or approval of the use of such products.

## CHAPTER 2

### SITE SELECTION

2-1. General. The most effective precaution that can be taken to assure a mark's stability and survival is to choose an appropriate location. Since there are a wide variety of possible situations that may be encountered when setting a mark, it is virtually impossible to address them all in this manual. Therefore, the ultimate selection of a site is necessarily left to the discretion of the mark setter; however, it is imperative that good judgment be exercised. The resultant accuracy of any survey will be determined in part by the stability of the marks. A mark setter exercising good judgment is defined as an individual who thoroughly evaluates the security, utility, stability, environment, and safety of the mark and its site before establishing the marks. The most important site selection parameters are discussed in the following sections.

2-2. Security. Foremost on the list of evaluation considerations is the mark's susceptibility to damage or destruction. In view of the great expense involved in establishing a mark and the data associated with it, time spent in preservation is worthwhile. It is necessary to anticipate any construction that might occur at the proposed mark location. Is the site selected for marks in the path of a future highway, waterway, ditch, or pipeline? Will an adjacent shopping center or parking lot be expanded in the foreseeable future? Is the prospective mark site near a potentially active mine or quarry? Highway maintenance often involves the widening of the road surface and the straightening of curves. Marks set near the edge of the right-of-way and on the outside of a curve increase their chances for survival. Conversely, the outside of a river bend is not an appropriate site for marks because the effects of erosion may lead to undercuts in the bank. The effects of undercutting may also occur on shoreline scarps where stormy waters slowly erode the embankment. Floodplains should be avoided when otherwise comparable sites are available. Marks located in floodplains may be buried in sediment or washed out due to erosion. Often, sites may be located in areas that provide natural protection for the mark. Locations near the edge of the right-of-way, well away from a highway surface, provide protection for marks. Property fence lines and utility poles usually remain in place for many years and afford good protection for marks. Structures that are of themselves not suitable for mark settings prevent vehicles and equipment from damaging marks that are set adjacent to them. In addition, from a standpoint of survival, Federal, state and local public areas, as well as private property and cemeteries, provide excellent sites for marks.

2-3. Utility. Accessibility of the marks by users should be evaluated in selecting the mark's site. If the mark cannot be found or if the site cannot be conveniently occupied, its worth

is questionable. Are there nearby objects that can be used to reference the mark? Are these objects fairly permanent? Can suitable measurements define a precise point where a hidden mark can be found? To enable the mark setter to establish a mark where its position can be accurately described, familiarity with referencing techniques is required. Marks are usually described in the following manner: Directions are given to the general area in which the mark is located. Normally, this puts the individual within 100 meters (328 feet) of the mark. Then the mark is located by distances and directions from prominent reference objects. These distances and directions establish lines of position (LOP). The prominent objects are referred to here as "origins." At least two LOPs are required to define a point, but additional LOPs are desired in case some reference objects are destroyed. Also, the more nearly perpendicular the angle at which LOPs intersect, the more accurately a position may be determined and the easier it will be to locate the mark. Consideration should be given to the ease with which the location of a mark may be established from reference measurements. It is important that this information be included on the mark documentation as discussed in paragraph 6-1.

2-4. Stability. All marks are subject to the effects of geologic and soil activity. Vertical control marks (bench marks) are particularly vulnerable because this activity results in vertical movements much more so than horizontal motion. Therefore, the following environmental effects should be evaluated when considering a mark site.

a. Advantageous Topographic Features. Crests of hills are good places to set bench marks for three reasons. First, the problem of slope instability is eliminated. Even though the neighboring hillside might be sliding, the summit will generally remain stable. Second, frost heave is less likely with the increased separation from the water table. And third, the consistency of the soil will tend to be more firm.

b. Effects of Soil Grain Size. Whenever soil types can be ascertained, it is preferable to choose a site with coarse-grained soils rather than one with fine-grained soils. Most of the problems associated with soil movements are attributable to the fine particles it contains. The fraction of grain sizes less than 0.02 millimeter governs whether or not a soil is frost susceptible. Soils susceptible to high volume change due to variation in moisture content are normally clays, which are very fine-grained. In addition, poorly drained clays provide environments conducive to corrosion. If an alternative is available, avoid sites with fine-grained soils, especially clays.

c. Effects of Vegetation. The presence of vegetation, particularly trees, has marked influence on the stability of the upper layers of a soil mass. Trees, underbrush, grass, and moss act as insulation, reducing the depth of the active frost zone and thus reducing frost heave. However, the problems associated



with expansive soils (clays) are aggravated by vegetation. In seasons of abundant rainfall, vegetation exerts very little influence on soil volume change. However, when the weather is dry and there is little free water available in the soil, trees and other plants will draw more water out of the soil than is normally lost through evaporation. The result is a lowering of the water table and even greater soil shrinkage. With trees, this effect occurs within a radial distance from the trees roughly equal to their heights. Areas covered with thick vegetation should be avoided even where expansive soils do not exist. Dense vegetation may conceal a monument, making it of much less value than one that is open to view. Marks should not be located near lone trees due to potential disturbances from growing roots.

d. Geological Effects. It is generally not feasible to determine the nature and extent of subsurface geological activity. Nevertheless, it is an important consideration that should never be overlooked when the information or a means of obtaining the information is available. Detailed geological data are very important in locating pockets of unstable ground within a generally stable area. Caverns and underground mines, as well as water and oil-bearing strata subject to pumping, are especially prone to cause significant subsidence. Marks established strictly for geodetic control should not be set in these areas. Whenever possible, sound bedrock should be used for a mark setting. However, it is often difficult to determine whether or not an outcrop is indeed sound bedrock, especially when the decision is based mainly on visual evidence obtained from an exposed portion of the formation. Where a large portion of the outcrop is exposed, try to insure that the section of rock in which the mark will be set is essentially intact with the rest of the outcrop. Carefully examine the surface of the bedrock to insure that it is solid and not in a state of deterioration. The margin of weathered rock can be surprisingly thick. If its surface has begun to crumble or contains deep fissures in close proximity, the outcrop is probably unsound and should not be used as a mark site. In this case, another type of mark or another location may improve stability. Some sedimentary rock, such as montmorillonite, contains detrimental clay minerals. Geological maps or expert advice may help determine if a sedimentary outcrop is expansive and therefore unsuitable as a mark setting. In this case, a site should be located in a structure or another rock outcrop. If this situation is not practical, a rod-type mark should be used. The effects of expansive bedrock due to variations in moisture content is not a problem if there is a sufficient overburden.

e. Man-made Structures. Since structures are subject to movements, fixing a mark on a structure does not assure that it will be a good geodetic control point. Before setting a mark it should be determined whether or not the structure will be as stable as a Type A rod mark (see Table 3-1). If not, use a Type B (see Table 3-1) or any other suitable rod mark. The stability of a large structure may be related to a Type B rod

14 Sep 90

mark by comparing the depth of the structure's foundation to the required depth of the rod mark sleeve. In addition, the structure should be a multistory design constructed of concrete, masonry, or steel. The Type B rod mark sleeve is set to a depth below that affected by expansive soils and frost heave. For a structure to be of comparable stability, the foundation need not be as deep as the rod mark sleeve. This is attributed to the weight of the structure, which can resist some of the expansive forces exerted by the soil. Also, the structure itself will have a shielding effect on the soil below, making conditions such as temperature and moisture content less variable. If the foundation of a structure is at least a quarter of the specified sleeve depth of a Type B rod mark, the structure is considered stable. Small structures, such as concrete culverts, platforms, retaining walls, bridges, etc., shall never be used for permanent monumentation. Very large bridges can be used if the structural member in which the monument will be set rests directly on bedrock, deep piles, or piers. Most structures are expected to settle both during and after construction. A structure less than 5 years old shall not be considered for vertical control marks unless its foundation is on bedrock. In general, a structure with a long life expectancy should be selected. Modern buildings will probably remain undisturbed for a long time. Older buildings of historical significance may provide a good site for a permanent monument. Caution should be taken to assure that the monument is placed in a location that is an integral part of the structure's foundation or fixed rigidly to it. Placing a permanent monument on an appendage, such as steps entering a building, is unacceptable unless the appendage has its own foundation of sufficient depth. Avoid sites that might be damaged or covered during any additional construction on or near the structure.

f. Miscellaneous Areas to Avoid. Sites near water reservoirs and large rivers, where the water level is variable, can rise and fall due to rebound and compression of the soil. This type of movement can have a significant effect on the precision of geodetic measurements. If possible, marks should be established a few hundred meters from the boundaries of these sources of ground activity. Permafrost has a stabilizing effect on marks anchored to a sufficient depth. Significant expansion and contraction of frozen ground due to temperature variation can occur to a depth of about 10 meters (33 feet). A permanent monument anchored below this depth can be expected to be quite stable. In regions where permafrost normally exists near the surface, sources of thawing can keep the ground in an unfrozen condition to a greater depth than expected. Any body of water, such as a pond, lake, or river, will have this effect. Other influential thawing sources include buildings, roads, pipelines; in short, any mark of civilization.

2-5. Corrosive Environment. The rate at which a material will corrode or deteriorate is affected by its environment. There are two conditions necessary for corrosion to occur. First, the metal being corroded must be in contact with an electrolyte or a

liquid capable of conducting electric current. Electrolyte composition may vary widely, ranging from a minute amount of nearly pure water formed by condensation to seawater. Secondly, there must be a dissimilarity in two areas of the surfaces being corroded. This could result from the presence of strains or inclusions in an alloy, the contact of dissimilar metals, or a variety of possibilities between these two extremes. The most important environmental factors governing the corrosive character of a soil are the degree of aeration and the presence of any water-soluble salts. Aeration is an important soil characteristic because many metals need exposure to oxygen in order to form a dense, tough layer of metallic oxide on their surfaces. The oxide coating prevents further corrosion by isolating the remaining metal from any electrolytes. Aluminum and steel protect themselves in this manner. Water-soluble salts have an influence on corrosion in two ways. First, the ions that form when salts dissolve improve the capability of the electrolyte to carry current. The greater the ability of the electrolyte to carry current, the faster corrosion will occur. Water with dissolved salts is a better electrolyte than pure water. A second effect of water-soluble salts is the influence they have on the formation of the dense, tough protective oxide layer that forms on the surface of certain metals. Rod marks will at times unavoidably be placed in corrosive soils. As a protective measure, rod marks placed in corrosive soils should be Type B made of Type 316 stainless steel. This material is more resistant to corrosion than other affordable alloys in nearly all environments. Nonetheless, steps may be taken to increase its life span. Stainless steel is most susceptible to corrosion in poorly aerated environments and those in which chlorides are present. Well-aerated soils are generally recognized by their red, yellow, or brown colors resulting from the oxidation of iron compounds commonly found in soils. Sites with this type of soil characteristic provide a good location for permanent monument setting. Poorly aerated soils are usually gray in color due to the lack of sufficient oxygen to oxidize the iron compounds. Soils of this type may also be identified by their poor drainage characteristics. Avoid areas where there is a high concentration of chlorides. Rod marks set along highways, where heavy salting might be done in winter, should be located at least 10 meters (33 feet) from the road surface. In general, setting marks along the edge of the right-of-way is a good practice. Although it will sometimes be impossible, due to project requirements, try to avoid saltwater shorelines. When the purpose of a project is to provide shoreline control, stay off the beach when possible. Another good indication of the corrosive character of a soil may be obtained if one has the capability to measure soil resistivity. The more resistant a soil, the poorer the electrolyte and, consequently, the less corrosive it will be.

2-6. Safety. If a mark extends below ground level, there is a chance of encountering underground cables or pipes during installation. This is especially a concern when drilling a hole for marks requiring sleeves or casings. This situation is more

critical in urban areas than in rural areas. Evidence of underground utility lines often can be observed at the surface. Water lines are marked by valve boxes at most street intersections. Avoiding the area between valve boxes will decrease the chances of hitting a pipe. Fire hydrants are a good indicator of the location of water mains. Hydrants usually are placed within a meter (40 inches) of the line and to the side away from the street centerline. Most water and sewer lines lie under the road surface, but some are placed adjacent to it. Therefore, avoid the area between the street and the sidewalk. Telephone and electrical cables are normally laid from 0.5 to 1 meter (1.6 to 3.3 feet) below the surface. Housing developments built in the 1960s and later are much more likely to have underground cables than those built before that time. The absence of telephone and power poles is conclusive evidence that there are underground cables in the area. However, the presence of utility poles does not necessarily indicate the lack of underground cables. Buried telephone lines usually run directly between junction box pedestals or between telephone poles. Electrical cables may run adjacent to telephone lines. When an electric appliance, such as an air conditioning unit or floodlight, is located apart from other structures, an underground cable to it would probably run directly from a metering device. Gas lines are generally harder to detect. Meters and valves are helpful in locating buried gas lines if they are not situated too far apart. As with telephone cable pedestals, do not drill or drive monuments in an area between visible gas devices. If circumstances permit, the best way to avoid problems is to contact the local metropolitan utilities commission. A utility locator service will locate underground utilities by painting the ground. Do not drill or drive monuments within 60 centimeters (2 feet) of either side of the painted line. In addition, it is wise to develop a habit of looking for "Buried Cable" signs. In conclusion, if other considerations in the site selection will allow, monuments may be set near utility poles, for greater security, avoiding the areas between adjacent poles.

2-7. Satellite Visibility. In addition to permanence, utility, and stability, satellite visibility must also be considered when selecting sites for monumentation for Global Positioning System (GPS) type surveying. The proximity of existing bench marks should also be considered when performing dynamic surveying. Sites that provide maximum visibility above the horizon, plus 15 degrees, should be selected. Any obstructions above 15 degrees will potentially block satellite signals. The site ideally should have visibility in all directions above 15 degrees; however, in some locations at specific times, an obstruction in one or possibly two directions may not affect the ability to use the site for GPS surveying. Existing bench marks should be utilized as often as possible as GPS monuments, or new marks should be located as close as possible to known vertical control. For maximum utility and economical use, maximum effort should be made to locate all GPS type monuments within 100 feet of easy access to vehicular ground transportation.

2-8. Cost Comparison. Experience has shown that the earth's crustal movement is dynamic in both the vertical and horizontal directions to various degrees at different sites. This is caused by a combination of several factors such as regional crustal plate movements, removal of subsurface fluids, soil shrinking and swelling, soil freezing and thawing, growth of vegetation, construction of new structures, and settlement of old structures. When developing a monumentation plan, a comparison should be made between the cost of additional monument installation and additional leveling to more stable areas that require less costly monuments. The average cost of second-order and third-order leveling per mile is presently \$800 and \$480, respectively. The average cost to install a Type A rod monument to 50 feet of depth is presently \$280. Additional depth beyond 50 feet will average \$3 per foot. In developing the cost comparison, future uses of the mark must be considered; e.g., if marks will be used frequently, there will be an additional future cost of leveling in locations where marks are constructed away from the immediate site where they are needed. In most cases, the cost of repeated or additional leveling will far exceed the extra cost required to install the most stable monument at the site where needed.

CHAPTER 3

VERTICAL CONTROL - BENCH MARKS

3-1. Selection of Monument Type Based on Local Site Conditions. Types of marks to be used for vertical control are a function of the order of accuracy of the survey, the intended use of the data collected, and the site conditions. The types of monuments that can be used for vertical control, depending on local site conditions, are identified in Table 3-1. Construction and installation details are discussed in the following paragraphs.

Table 3-1

Site Conditions and Monument Types for Vertical Control

Site Conditions	Order of Accuracy			
	High	1	2	3
Rock outcrops, large boulders, bedrock concrete structures (more than 5 years old)	C	C	C	C
Granular soils (sand and gravel)	B	A,B	A	F,G
Glaciated soils (till)	B	A,B	A	F,G
Fine-grained soils (silts and clays with high bearing strengths)	B	A,B	A	F,G
Fine-grained soils (silts and clays with low bearing strengths)	B	A,B	A	A
Construction fill (disturbed earth)	B	A,B	A	A
Permafrost	E	E	D,E	D
Marsh	B	B	B	A
Subsidence area	B	B	B	A

a. Type A - Deep Rod - Aluminum with Finned Section. Type A rod marks (Figure 3-1) should be used when sound bedrock or substantially stable structures are not available. The mark is provided with extra horizontal stability required for three-dimensional surveys, which makes the mark a suitable GPS mark. This mark should not be used in highly corrosive environments.

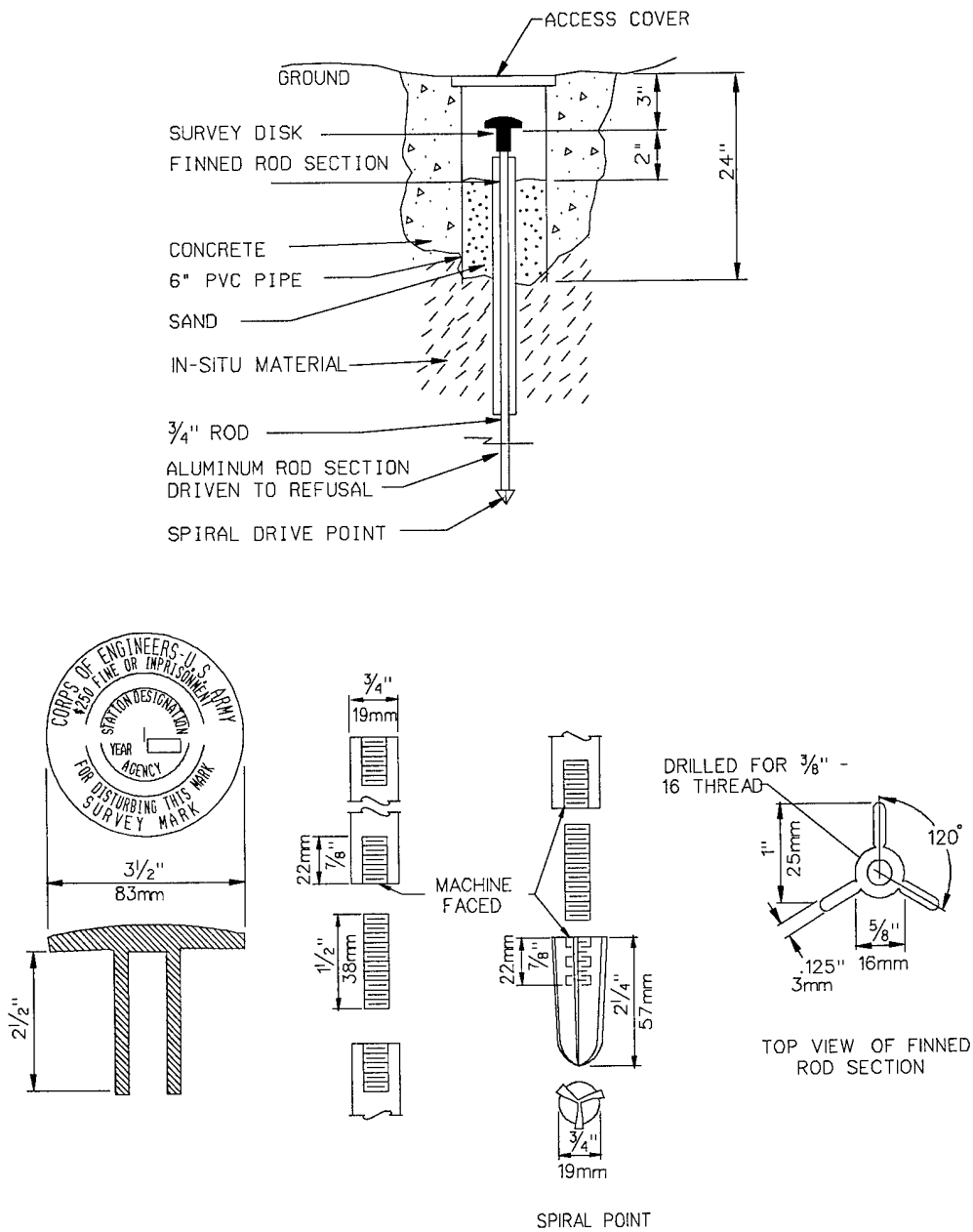

USE FOR VERTICAL, HORIZONTAL AND BOUNDARY CONTROL

Figure 3-1. Type A monument - deep rod - 3-foot finned section

Table 3-1 indicates the recommended usage for the Type A monument.

b. Type B - Deep Rod - Stainless Steel with Sleeve. Type B rod marks (Figure 3-2) should also be used when sound bedrock or substantially stable structures are not available. Type B rod marks shall always be used in highly corrosive environments. Since this mark is also provided with horizontal stability, it may also be used as a three-dimensional monument.

c. Type C - Disk in Bedrock or Concrete Structures. Sound bedrock is the most desirable location for a bench mark as illustrated by Type C monument (Figure 3-3); it provides the most stable setting in terms of both underground activity and potential disturbances. Always use bedrock when a suitable outcrop exists. As a rule of thumb, a bedrock outcrop is considered acceptable if the distance between adjacent joints and fissures is greater than 1 meter (40 inches).

d. Type D - Deep Rod - Frost Resistant (Anchored in Permafrost). Changes in bench mark position caused by frost heave can occur where soil freezes and thaws annually. This problem is most severe where annual frost penetrates deeply. Figure 3-4 illustrates the maximum depth of frost in meters for the United States. Significant subsurface movement of soil in permafrost areas can occur to depths of up to 9 meters (30 feet), and conventional bench marks can be moved several inches due to frost heave in winter and subsequent settlement during summer thaws. Type D monuments are frost-resistant bench marks designed to be anchored in permafrost (Figure 3-5).

e. Type E - Deep Rod - Frost Resistant (Anchored Below Permafrost). The primary difference between the Type E rod and the Type D rod is that the Type E will be anchored below permafrost as illustrated in Figure 3-6. Type E monuments shall be selected when the greatest monument stability is required in a permafrost area.

f. Type F - Shallow Rod - Finned, No Casing. The Type F shallow rod mark may be used in granular soils such as sands and gravels, glaciated soils or fine-grained soils such as silts and clays with high bearing strengths. The Type F rod mark is suitable for third order accuracy. If higher order accuracy is needed, then the Type A or Type B rod mark should be selected. The Type F rod mark is illustrated in Figure 3-7. Type F monuments shall also be used for reference and azimuth marks.

g. Type G - Disk in 3/4-inch Pipe or on Rebar. The Type G rod mark is selected for the same sites as the Type F mark; the primary difference is construction and installation details. The Type G rod mark is illustrated in Figure 3-8. Type G monuments shall be selected in lieu of Type F monuments when circumstances will allow the construction of the Type G monument.



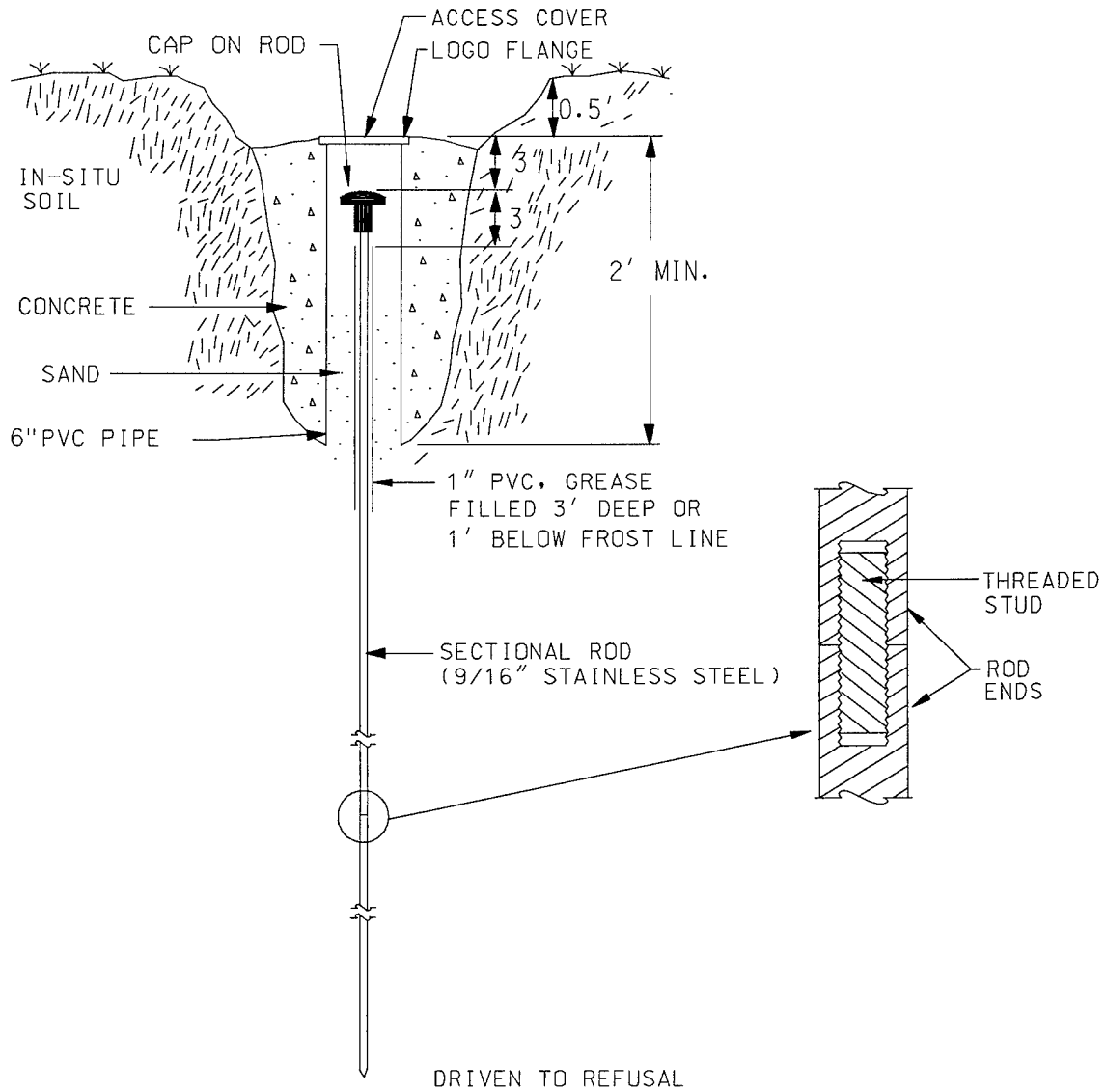

USE FOR VERTICAL AND HORIZONTAL CONTROL

Figure 3-2. Type B monument - deep rod - stainless steel with sleeve

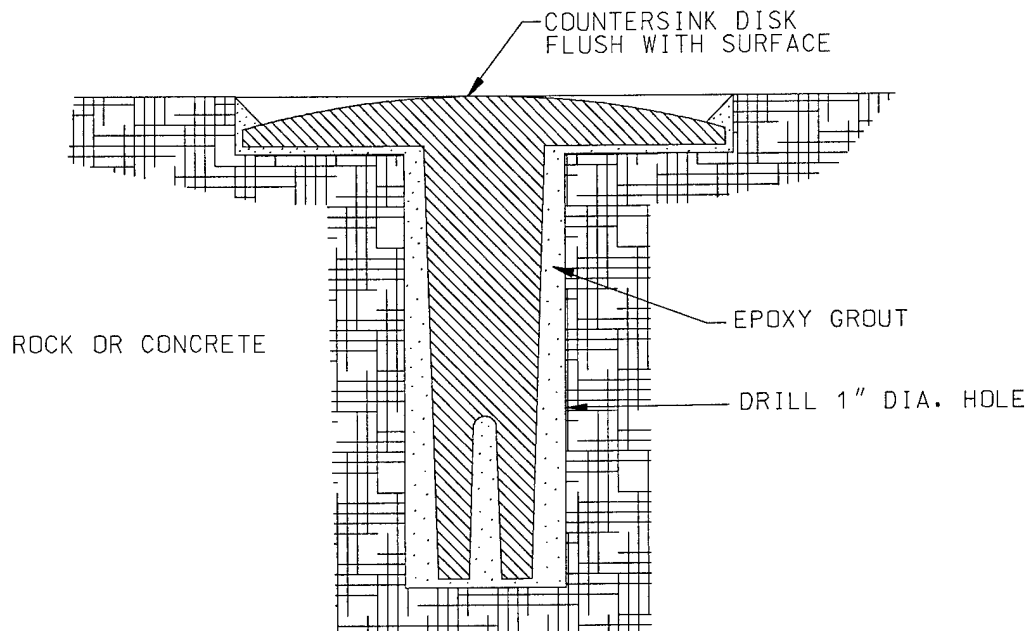

USE FOR VERTICAL, HORIZONTAL AND BOUNDARY CONTROL

Figure 3-3. Type C monument - disk in rock or precast concrete

h. Deep Bench Marks in Clay. When the site geology is known to consist of sensitive clays, the Type B rod mark should be used. The PVC sleeve should extend through the sensitive clay layer. The anchored section should be driven to refusal. When the site geology is known to consist of lacustrine clays, the Type B rod mark should be used. The PVC sleeve should extend through the highly desiccated soil.

i. Natural or Ready-Made Bench Marks. Occasionally, a natural or ready-made bench mark setting, which cannot accommodate a brass disk, will exist that would be more stable than a rod mark.

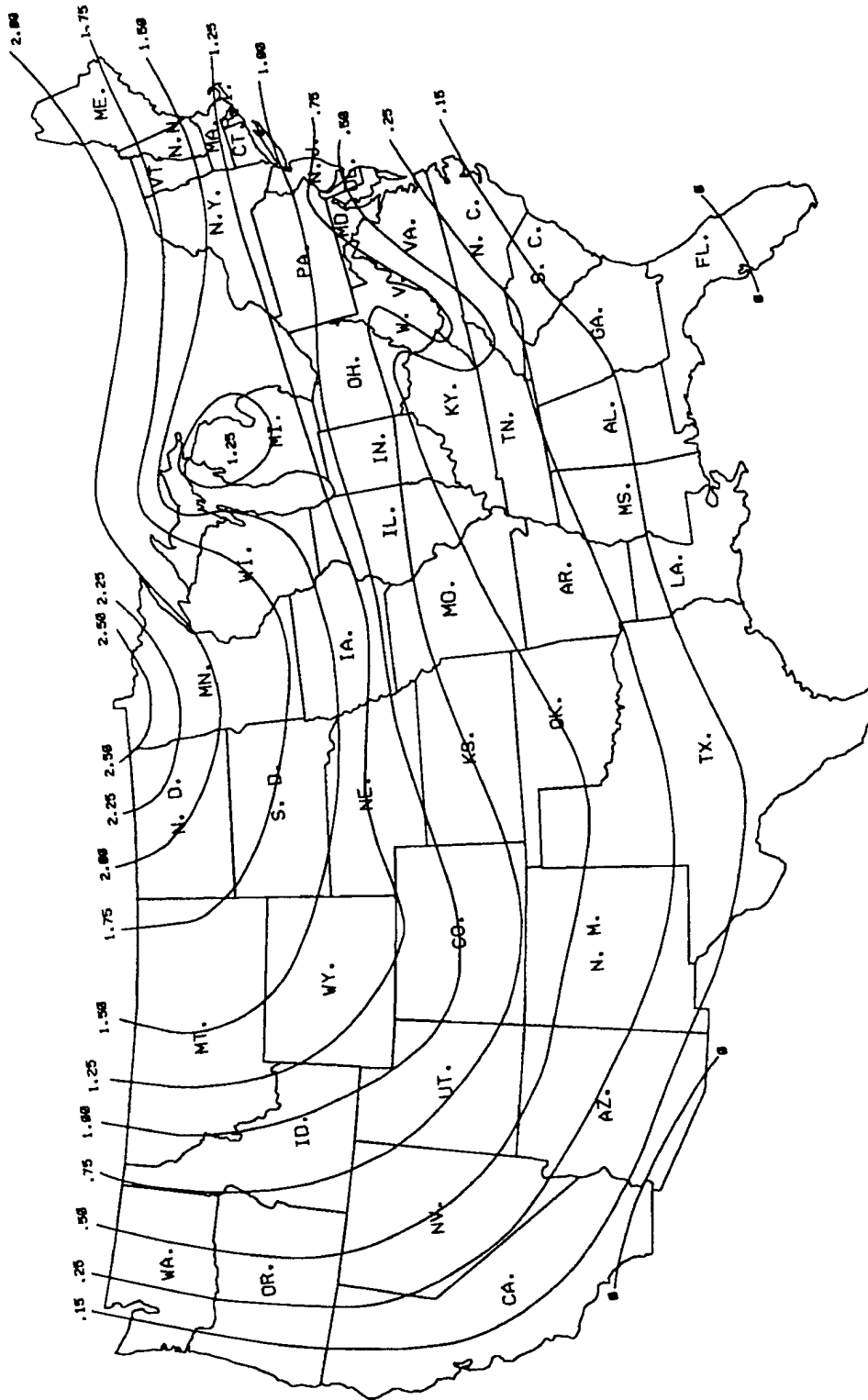
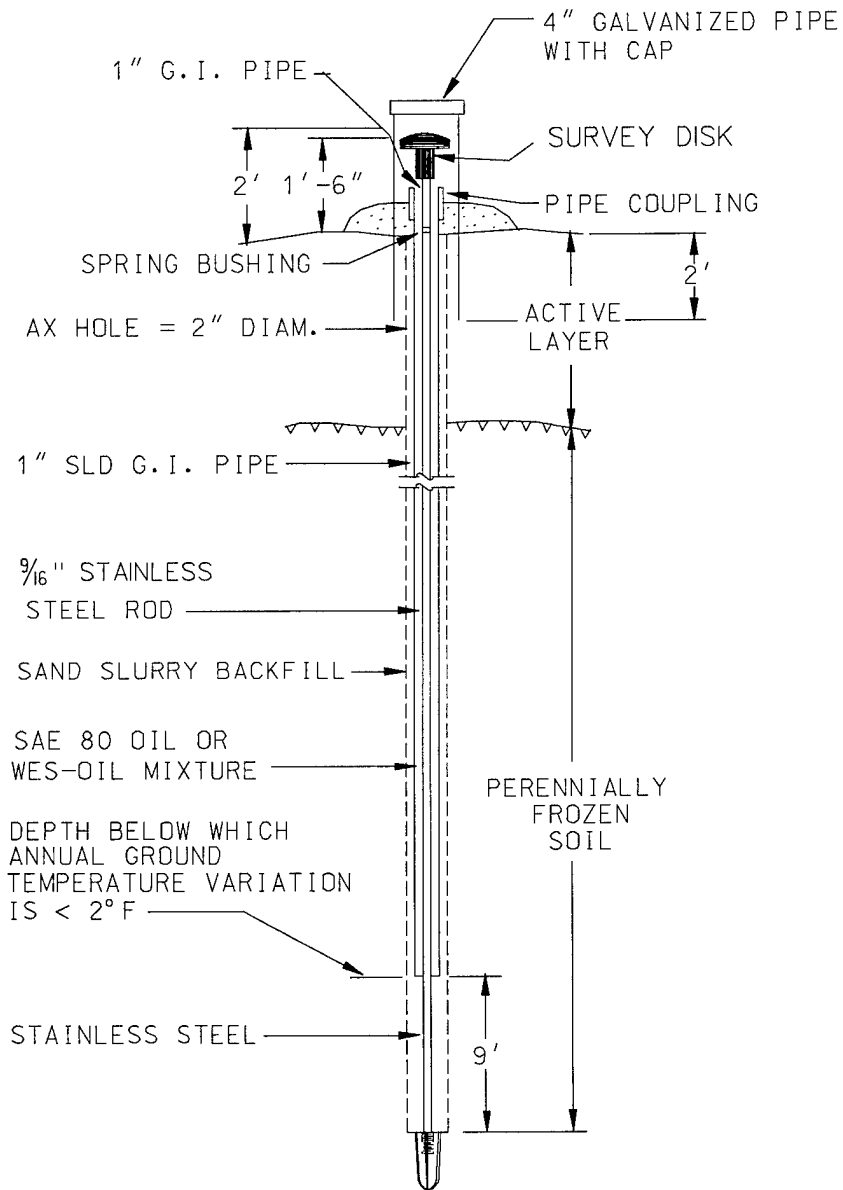

Figure 3-4. Maximum depth of frost (meters)



ANCHORAGE IN PERMAFROST

USE FOR VERTICAL AND HORIZONTAL CONTROL

Figure 3-5. Type D monument - deep rod - frost resistant in permafrost

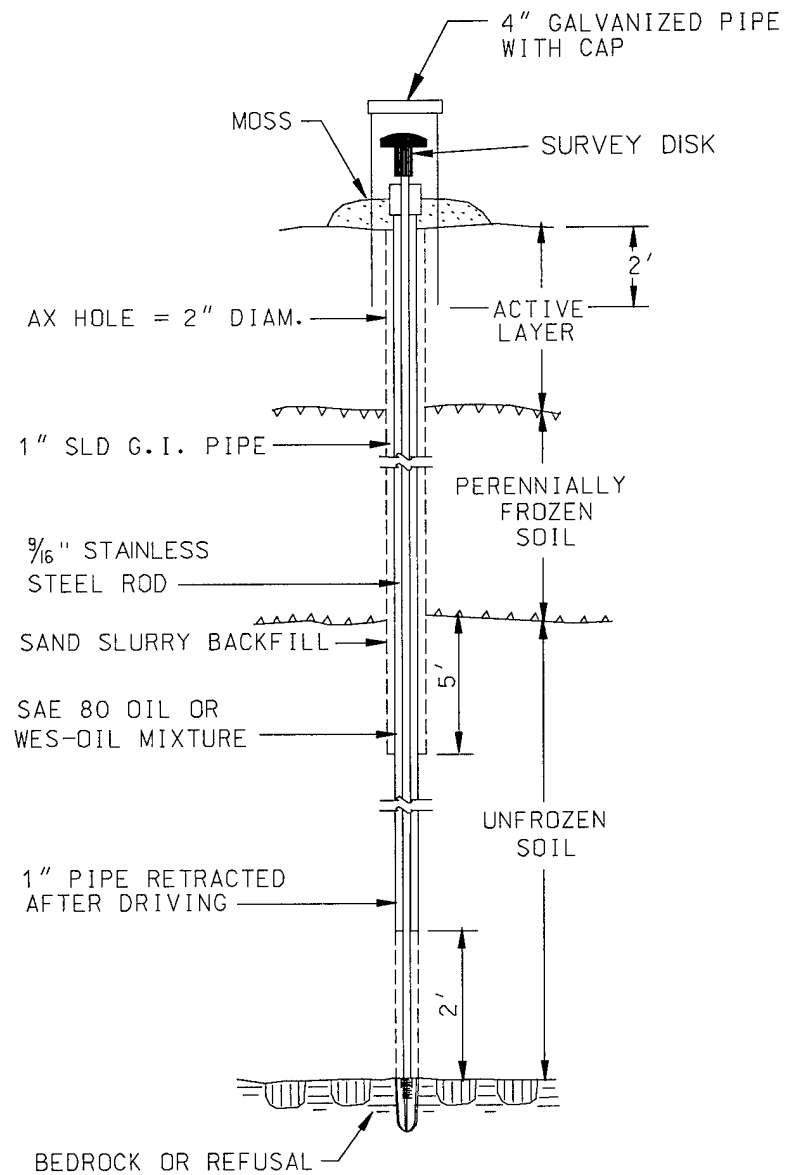

ANCHORAGE BELOW PERMAFROST

USE FOR VERTICAL AND HORIZONTAL CONTROL

Figure 3-6. Type E monument - deep rod - frost resistant below permafrost

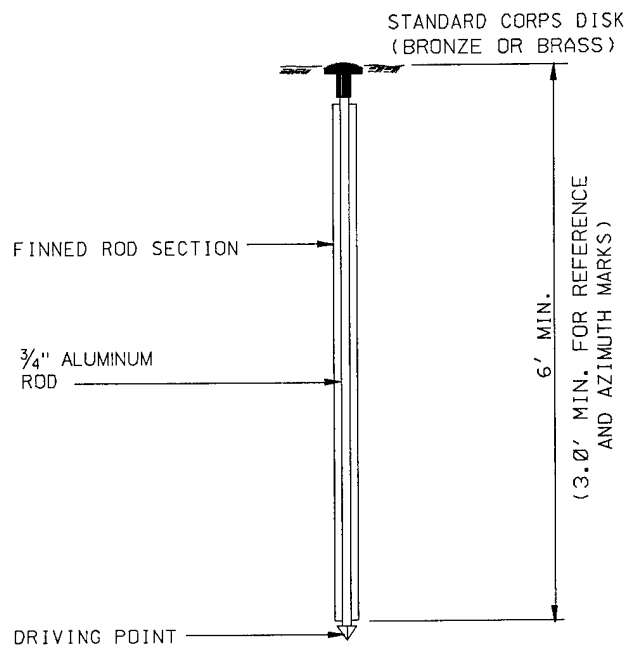

USE FOR HORIZONTAL, BOUNDARY, REFERENCE AND AZIMUTH CONTROL

Figure 3-7. Type F monument - disk on shallow rod

An example is a deep well casing. It would resist not only near-surface movements but also, to a degree, movements originating in the subsurface, such as subsidence from pumping. A good illustration of this can be seen in Santa Clara Valley, California, where well casings project prominently because of ground subsidence. These settings should not be ignored simply because a disk cannot be mounted on them. Settings of this type may furnish excellent references for elevations, provided they extend at least three times as deep as the required sleeve depth for a Type B rod mark in that area. It is important to select a good point of reference for the elevation of this type of bench mark. A prominent protrusion can be used if it is definite and has a good high point on which to rest a rod. Alternatively, a cross may be etched with deep, fine lines on a spot accessible to a leveling rod or tape. If possible, stamp or etch the bench mark designation and year nearby.

3-2. Construction and Installation Procedures. All USACE survey disks and access covers shall be stamped using 3.17-millimeter (1/8-inch) steel dies. All stamping shall deform the disk surface by a minimum of 1 millimeter (0.0394 inch).

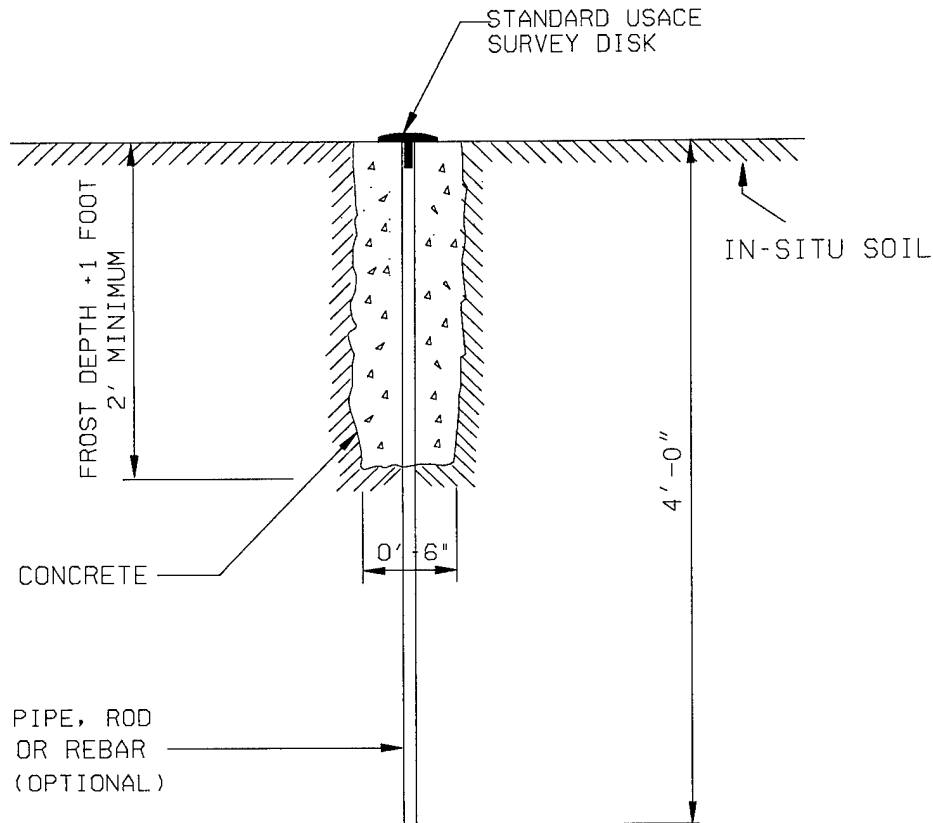

Figure 3-8. Type G monument - disk in cast-in-place concrete

a. Type A - Deep Rod - Aluminum with Finned Section. The construction details are shown in Figure 3-1. The mark is assembled from 3- and/or 4-foot sections of 3/4-inch aluminum alloy rod. The casing is constructed of a 15.2-centimeter (6-inch) PVC pipe 0.6 meter (24 inches) long, fitted with an aluminum access cover at the top. The access cover is imprinted with the information shown in Figure 3-9. The mark name shall be stamped on the access cover at "Mark Designation." The cover and pipe are placed around the top of the mark. Approximately 20 liters (2/3 cubic foot) of concrete is poured around the PVC pipe and access cover to hold them in place and to aid in recovery. The top 4-foot rod section is finned to provide horizontal stability. This type of monument is designed to prevent near-surface soil movements from disturbing the monuments. The rod assembly is driven or pressed to refusal into the soil so that it is anchored below the layers of disturbance. Refusal is defined as the depth at which the rod refuses to drive further or until a driving rate of 60 seconds or less per foot is achieved with a power reciprocating rod driver such as a Pionjar Model 120 or similar device

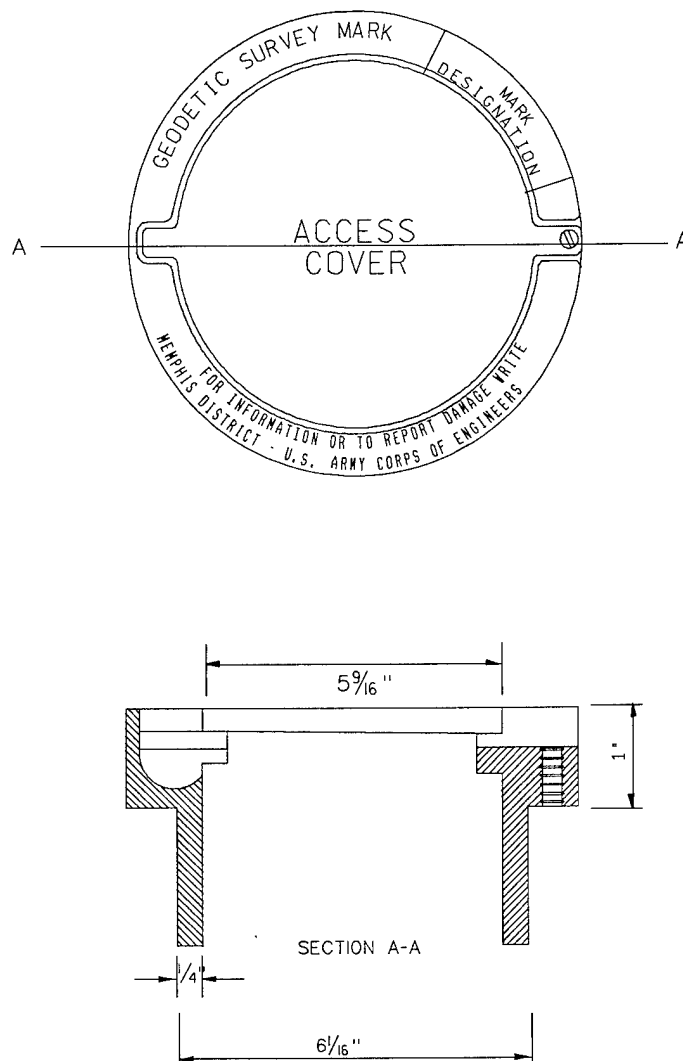

Figure 3-9. Standard access cover

with equivalent driving force of 26.9 foot-pounds/blow and an average of 2,500 blows per minute. The procedure for setting a Type A rod mark is as follows:

(1) Using an appropriate solvent for PVC, glue the aluminum flange to one end of a 0.6-meter (24-inch) section of 15.2-centimeter (6-inch) PVC pipe.

(2) Dig a hole 30 centimeters (12 inches) in diameter to a depth of 0.6 meter (2 feet).



(3) Drive the first section of rod in the center of the hole. Make sure it remains plumb while driving. Couple another section of rod tightly to the first and continue to drive the assembly. To obtain tight joints, hand tighten the sections and then apply another one-quarter turn with a wrench or wrenches. Repeat this procedure until the driving rate is near refusal. The last rod section shall be a 3-foot finned rod section driven such that its top is 3 inches below the surface.

(4) Stamp the name and year on the USACE disk (Figure 3-10) and drive the disk onto the rod. The disk should be driven on the rod about 1 inch.

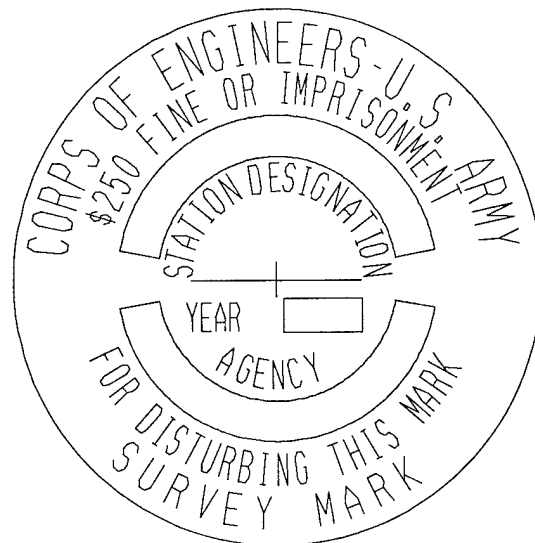

RECESSED LETTERS  
3-1/2 INCH DIAMETER  
BRASS/BRONZE

Figure 3-10. Standard survey disk

(5) Center the PVC pipe and access cover assembly over the rod. Backfill inside the pipe with sand to about 5 centimeters (2 inches) below the top of the rod.

(6) Mix about 20 liters (2/3 cubic foot) of concrete and place around the outside of the PVC pipe. Finish the top surface of the concrete so that it slopes slightly away from the top of the access cover.

b. Type B - Deep Rod - Stainless Steel with Sleeve. The construction details are shown in Figure 3-2. The rod is assembled from 3- and/or 4-foot sections of 1.43-centimeter (9/16-inch) Type 316 stainless steel coupled with threaded studs of the same material. The rod itself anchors the datum point to

a stable stratum of soil. For the most stable mark, the sleeve is required to isolate the rod from soil movements occurring above the stable stratum. The sleeve may be omitted if no soil movements are expected; however, stability will be reduced. To avoid movements caused by frost heave and soil shrinking and swelling, extend the sleeve to the maximum depth to where these types of soil movements are expected to occur. The procedure for setting a Type B rod mark is identical to that of the Type A rod mark with the exception of the sleeve and the finned section.

(1) Using an appropriate solvent cement for PVC, glue the aluminum flange to one end of a 0.6-meter (24-inch) section of 15.2-centimeter (6-inch) PVC pipe.

(2) Construct the sleeve by gluing a PVC cap, with a drill hole of adequate diameter to accommodate the rod, on each end of a 1-meter (3-foot) or longer section of 2.54-centimeter (1-inch) schedule 40 PVC pipe. Fill the sleeve with an insoluble, non-corrosive, cold weather type grease.

(3) Dig a hole 30 centimeters (12 inches) in diameter to a depth slightly greater than 1 meter (3 feet) or the depth required to place the sleeve pipe base 30 centimeters (1 foot) below the frost line.

(4) Taking care not to deform its end, by using a drive adapter, drive the first section of 1.43-centimeter (9/16-inch) stainless steel rod down to just above ground level. Make sure it remains plumb while driving. Couple another section of rod tightly to the first and continue to drive the assembly as noted in paragraph 3-2a.

(5) Insert the capped 1-meter (3-foot) or longer grease-filled section of 2.54-centimeter (1-inch) PVC pipe over the 1.43-centimeter (9/16-inch) rod. The PVC sleeve should extend at least 30 centimeters (1 foot) below the local frost line if the frost line is deeper than 90 centimeters (3 feet). The rod should protrude approximately 5 centimeters (2 inches) above the sleeve.

(6) Stamp the name and year on the survey mark disk (Figure 3-10) and drive the disk onto the rod.

(7) Backfill around the outside of the sleeve with sand to about 60 centimeters (24 inches) below ground. Install the 0.6-meter (24-inch) section of 15.2-centimeter (6-inch) PVC pipe with aluminum access cover over and around the sleeve and rod.

(8) Backfill the inside of the 15.2-centimeter (6-inch) PVC pipe with sand around the outside of the sleeve and rod to about 2.54 centimeters (1 inch) below the top of the sleeve.

(9) Pour concrete around the outside of the pipe and finish as outlined in paragraph 3-2a.

c. Type C - Disk in Bedrock or Concrete Structure. The Standard USACE disk (Figure 3-10) is made of brass or bronze. It is 8.9 centimeters (3.5 inches) in diameter with a spherical surface to support the foot of a leveling rod. Information is printed on this surface to identify the monument and to aid the user in obtaining important data. So as not to interfere with placement of the leveling rod, logo information is recessed in the surface of the disk. A deformed shank, about 7.5 centimeters (3 inches) long, is attached to the bottom surface of the disk to help prevent the disk from being dislodged from the monument. In addition, disks with tubular shanks are used when driven on rod marks. The step-by-step procedure for setting the disk in bedrock is as follows:

(1) Stamp the designation and year on the top surface using 3.17-millimeter (1/8-inch) steel dies.

(2) Pick a fairly level and accessible spot on the outcrop that is intact with the bulk of the rock.

(3) Drill a hole 2.5 centimeters (1 inch) in diameter about 10 centimeters (4 inches) deep into the bedrock. Recess the area around the top of the hole to a diameter slightly larger than that of the disk. When the installation is completed, the top surface of the disk should set level and flush with the surrounding rock. Caution: Safety goggles should be worn when drilling into bedrock or masonry.

(4) Remove any rock powder from the hole and recessed area. Fill the drilled hole with clean water and then pour in the epoxy or non-shrink grout. Mixing of the ingredients may be done in the hole. Premixed grout may be used if desired. By adding more water and grout, mix enough grout so that an extra amount is available for the underside of the disk and, if applicable, the inside of the shank. A properly mixed grout should be thick but still workable.

(5) Fill the depression on the underside of the disk with the additional grout. If the disk has a tubular shank, fill the shank with grout. This step is very important; it will prevent highly undesirable voids under the disk once it is in place.

(6) Place the shank of the disk into the drilled hole and press the mark firmly into place. Work the excess grout completely around the outer edge of the disk, making sure that it is smooth and flush with the top surface. An exposed edge of the disk would provide an area that could be used by someone to dislodge the disk. Excess fresh grout on the upper surface of the disk can easily be cleaned off.

(7) Sprinkle some dry cement on the exposed surface of the disk; then rub it with a clean rag using circular strokes. This will clean the disk very nicely, removing all excess grout from its surface and recessed letters. Rubbing the wet grout around

the edge of the disk in the same manner will do no harm. In fact, this is often done intentionally to finish its surface and prevent cracking. Brush away loose cement and make sure that the finished product has a very neat appearance.

(8) To prevent heavy rains from ruining its surface and/or to prevent the disk from being tampered with, the grout must be covered until it is set and dry. A piece of wood, cardboard, heavy paper, or any other similar biodegradable material will suffice.

(9) The installation is not complete until all accumulated trash has been picked up. Leave the monument location in a neat and orderly appearance.

When setting a disk in a massive concrete or masonry structure, first make sure the structure is stable. The required foundation depth is at least equal to a quarter of the specific sleeve depth of a Type B mark (Figure 3-2). The disk may be mounted vertically in a wall of a structure but should be set horizontally if possible. The procedure for setting a disk horizontally in a structure is identical to that for setting one in bedrock. Again, make sure safety goggles are worn when drilling into masonry or concrete. For a vertical setting, the hole for the disk's shank must be drilled horizontally; therefore, the mortar must be mixed separately. When drilling into brick or other soft material, a hammer and star drill should be used rather than heavy power equipment. This prevents the possibility of extensive damage to the exterior. The inside of the drilled hole should be wetted before any mortar is applied. After placing the shank of the disk into the mortar-filled hole, the disk should be worked to the bottom edge of the hole. This will prevent the possibility that the disk will settle askew while the mortar is curing.

d. Type D - Deep Rod - Frost Resistant (Anchored in Permafrost). Construction of this type of monument should be accomplished when the ground is frozen. Plywood should be used in the work area to minimize surface disturbances that destroy the organic mat around the bench mark leading to deepening of the active frost layer and possible instability of the monument. The installation of this bench mark design is outlined below.

(1) Carefully position the drill rig so that disturbance of the moss cover will be kept to a minimum. Place a suitable length of NX (4-inch) casing through the active layer into the perennially frozen ground to prevent thawed material and surface water from entering the hole. Drill a hole to a depth of 39 feet with AX (2-inch) size drill equipment, using an AX core barrel if samples are desired; otherwise, use an AX non-coring bit. If caving occurs, AX drill casing should be placed to the bottom of the hole. When the hole is completed, bail out all the water.

14 Sep 90

(2) Connect the drive point to a section of 9/16-inch stainless steel or aluminum rod and lower it into the hole to a depth of 8 feet. String a 10-foot length of 1-inch pipe over an 11-foot length of the rod. With vice grips or another device securely clamped to the top of the inner pipe to prevent it from sliding out of the 1-inch casing, raise the two pipes vertically above the hole and connect the rods. Retaining a hold on the outside pipe, lower the assembly into the hole, adding successive sections of rod and 1-inch pipe until the drive point rests on the bottom. Secure the 1-inch pipe so that it projects about 6 inches above the ground. The inner pipe should protrude above the outer pipe.

(3) Holding the pipes in this position, carefully backfill the hole with a sand-slurry mix so that it just pours easily. If drill casing has been used, withdraw it carefully so that the relative positions of the bench mark rod and pipe are maintained as the hole caves in around them. To ensure that the lower portion of the datum pipe is adequately surrounded by soil, it may be necessary to fill the lower part of the hole with the slurry before removing the drill casing. If this is the case, even greater care is required to maintain the relative positions of the bench mark rod and pipe as the drill casing is removed.

(4) Remove the NX casing from the active layer and backfill the hole to the ground surface, carefully replacing the moss cover around the pipes.

(5) Fill the annular space between the inner and outer pipes with an SAE 80 gear oil or a special wax-oil mixture. This mixture can be made up of 70 percent oil (such as Mentor 29) and 30 percent wax (such as Socony Mobil Cerise AA) by weight, mixed after heating to about 200°F. The mixture is poured into the assembled sections of pipe and allowed to congeal before the pipes are placed in the drill hole.

(6) Install the "spring bushing" inside the top of the 1-inch pipe casing. The top of the rod shall be rounded to provide a single point of contact. Center punch the datum point for a three-dimensional monument.

(7) A 4-foot length of 4-inch pipe with pipe cap shall be driven into the ground over the bench mark assembly to provide protection.

e. Type E - Deep Rod - Frost Resistant (Anchored Below Permafrost). Construction of this type of monument should be accomplished when the ground is frozen. Plywood should be used in the work area to minimize surface disturbances that destroy the organic mat around the bench mark leading to deepening of the active frost layer and possible instability of the monument. The installation of this bench mark design is outlined below.

(1) Following the same procedures given above, drill an AX hole to a depth 5 feet below the perennially frozen layer.

(2) If the unfrozen soil underlying the permafrost is relatively soft, complete the installation by driving the 2.54-centimeter (1-inch) pipe and the rod to refusal; then retracting the 2.54-centimeter (1-inch) pipe 0.6 meter (2 feet) above the refusal point.

(3) If the unfrozen soil is stony or very stiff, it may be necessary to extend the borehole to bedrock or other resistant material. In this case, the installation may then be completed by following the procedures used for anchoring bench marks in permafrost previously discussed.

f. Type F - Shallow Rod - Finned, No Casing. The construction details are illustrated in Figure 3-7. The Type F mark is constructed of two 90-centimeter (3-foot) aluminum alloy finned rod sections with a USACE disk driven on the top section. The rods are driven or pressed into the soil such that the USACE disk is flush with the ground surface.

g. Type G - Disk in 3/4-inch Pipe or on Rebar. The construction details are illustrated in Figure 3-8. The Type G mark is constructed by excavating a 15-centimeter (6-inch)-diameter by 60-centimeter (2-foot)-deep hole. In areas where the maximum frost depth is greater than 2 feet, the excavated depth should be 1 foot below the maximum frost depth. The USACE disk may be driven into a 4-foot by 3/4-inch diameter pipe or on a 4-foot by No. 5 reinforcement steel bar (rebar). The pipe or bar assembly is then driven into the center of the hole until the disk is slightly above the surface. The hole is then filled with concrete to the disk. The use of a pipe or rebar is optional. The disk may be pushed directly into the fresh concrete; however, a magnet shall be placed in the concrete if pipe or rebar is omitted.

3-3. Naming Vertical Control Monuments. A vertical control point, commonly referred to as a "bench mark" (BM), should be identified by a number or by an alphanumeric symbol stamped on the respective disk marker (or otherwise inscribed on the bench mark monument or access cover). In principle, the name that identifies a vertical control point for publication purposes should be the same as the name that actually appears on the marker. However, extraneous information, which is not part of the name, frequently appears on the marker. For example, the name of a bench mark should not include the elevation. The name does not generally include the "year mark set". Tidal and water level stations should also be named in accordance with these instructions.

a. Maximum Character Length. A bench mark name must not exceed 25 alphanumeric characters (including all imbedded

EM 1110-1-1002  
14 Sep 90

blanks). Abbreviate and/or edit a name as necessary to conform to this limit.

b. Organization Acronym. A name should always include the acronym or abbreviation of the agency or organization that set the mark if it is not precast or stamped on the survey marker (for example, USE for U.S. Engineers). In addition, a District or Division acronym may also be included as part of the name if it is not precast or stamped in the marker. The agency and/or organization acronym should not be stamped on the disk as part of the name. However, they may be appended to the name for publication.

Example Names

2903  
V 16 RIRR

c. Special Characters. The only special characters permitted in a bench mark name are the blank ( ), plus (+), minus or hyphen (-), equals (=), slash (/), and decimal point (.). When used, these special characters must not be separated from adjacent characters by any blanks. Commas and parentheses are not allowed to appear in a bench mark name.

Example Names

CH 1174=297+00 A  
H 23

d. Character Groupings. All alpha and numeric character groupings in a name must be separated by a blank. Care should be taken that only one blank is used for this purpose. Two blanks in a row will be interpreted as the end of the name.

Example Names

MEM 123 B  
BEALE 17 B  
TT 1 7 B

e. Unacceptable Names. The characters "NO" or "NO." should not be included in the name when used as the abbreviation for the word number. A period may not appear imbedded in or adjacent to a grouping of alpha characters. However, a decimal point may appear imbedded in, or adjacent to, a grouping of numeric characters. Non-specific descriptive terms such as "bench mark," "BM," "chiseled square," "bolt," "red," "nail," or "spike" should

not be used as part of the name. The elevation should not be stamped on the disk marker or otherwise inscribed on the bench mark monument.

Acceptable Example Names

MI 14.2  
4419.  
PALMER NE BASE

f. Multiple Names. For bench marks that carry multiple stamped names, the information imprinted should be concatenated with the equal sign (=) used as a separator (subject to the 25-character total length limit).

Example Names

H 13=872 2621 TIDAL USE  
STA 3=MI 182.5 USE  
LEE RM 1=R 13 USE

g. Reset Names. When resetting marks, always use a new unique name for each station reset. Do not use "Reset" as part of the name.

h. Temporary Bench Marks. A temporary bench mark (TBM) must carry the letters "TBM" as the first three characters of the name.

Example Names

TBM 1 A  
TBM 14

3-4. Marks of Other Organizations. If a satisfactory vertical control monument of another organization is found at the project site in good condition, it may be used without alteration as the station mark of a new USACE Survey Monument. In case the existing mark of the other organization is not in good condition for a station mark, a new station mark should be established in the vicinity, and the mark of the other organization should be used as an extra reference mark. The stamping of additional marks should be done as indicated in this manual. Care should be taken not to displace a mark of another organization in horizontal position, or even in vertical position if there is a possibility that it could be used as a bench mark. The mark should not be altered without permission from the organization that established it.



EM 1110-1-1002  
14 Sep 90

3-5. Witness Posts and Signs. In order to aid in the preservation and to serve as a means of easy recovery of monuments being established, a witness post should be set adjacent to the monument or near one of the reference marks at each station. This post should be 1.8 meters (6 feet) in length and be set to a minimum of 1 meter (3 feet) above the ground surface. The post should have the standard witness post sign attached (Figure 3-11). Witness posts shall be set for monuments of third-order accuracy and above, established along public highways, in rural districts, along the rights-of-way of railroads, and along the shorelines of rivers and lakes. They need not be set for monuments established along business streets, in residential sections of cities, on the grounds of a school or a church, in cemeteries, in cultivated farmlands, or on bare mountain tops. For survey monuments established below grade or in cultivated fields and marked with an underground mark, the post shall be set at a reference mark.

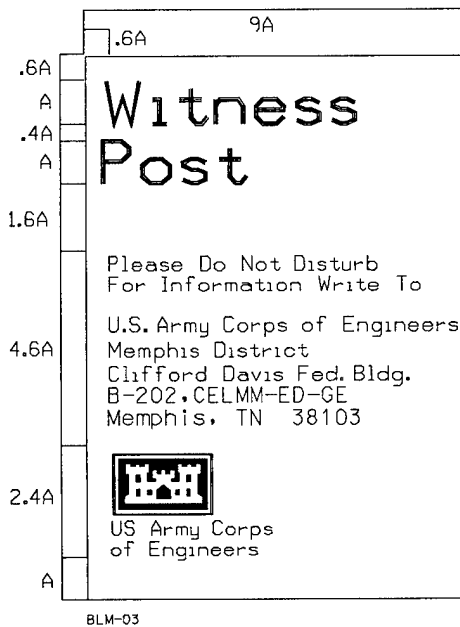
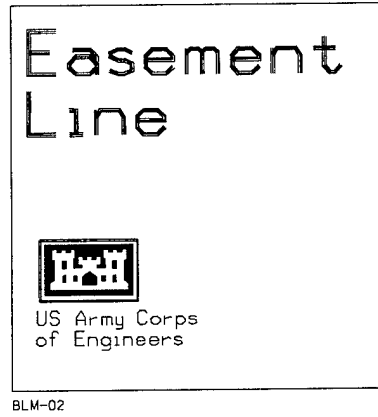
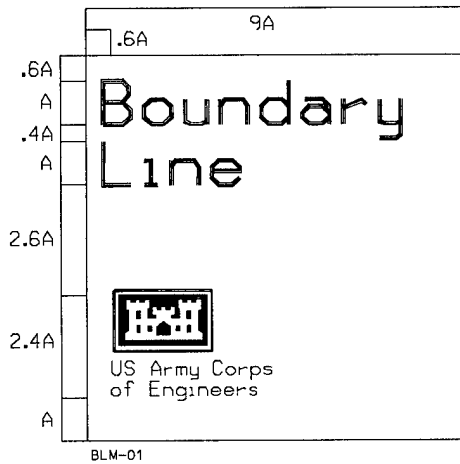

SIGN TYPE	LEGEND SIZE (A)	PANEL SIZE	POST SIZE	SPECIFICATION CODE	MOUNTING HEIGHT	COLOR BKG/LGD
BLM-01	.3437	3.5"x3.5"	4"x4'	SCP-7	36" MIN.	WH/BK
BLM-02	.6875	6"x6"	4"x4'	SCP-7	36" MIN.	WH/BK
BLM-03	.3125	2.875"x2.875'	3.75"x.5'	SCP-10	36" MIN.	WH/BK

Figure 3-11. Standard property markers

CHAPTER 4

HORIZONTAL CONTROL MONUMENTS

4-1. Selection of Monument Type Based on Local Site Conditions. Types of monuments to be used for horizontal control are a function of the order of accuracy of the survey, of the intended use of the data collected, and of the location provided. The various monuments that should be used to provide horizontal control only are identified in Table 4-1. The site selection criteria have previously been discussed in paragraph 3-1. If higher order accuracy other than that illustrated in Table 4-1 is desired, then a Type A rod mark should be used. High precision engineering and deformation studies require extremely stable monuments, i.e, instrument pedestals and force-centering devices. Other rod type monuments in this manual may also be used for horizontal control as well as vertical control.

4-2. Construction and Installation Procedures. Construction details for rod marks have been previously discussed in paragraphs 3-2a. through 3-2g. Instrument pedestals shall be

Table 4-1

Site Conditions and Monument Types for Horizontal Control

Site Conditions	Order of Accuracy			
	High	1	2	3
Rock outcrops, large boulders, bedrock concrete structures (more than 5 years old)	C	C	C	C
Granular soils (sand and gravel)	G	G	G	F,G
Glaciated soils (till)	G	G	G	F,G
Fine-grained soils (silts and clays with high bearing strengths)	G	G	G	F,G
Fine-grained soils (silts and clays with low bearing strengths)	G	G	G	G
Construction fill (disturbed earth)	G	G	G	G
Permafrost	E	E	D	G
Marsh	A,B	A,B	A,B	A,B
Subsidence area	A,B	A,B	A,B	A,B

14 Sep 90

constructed as shown in Figure 4-1. The centering device should be constructed as outlined in Figures 4-2 and 4-3 and should have a protective cover. It is recommended that soil and/or geotechnical specialists be consulted prior to construction of instrument pedestals. All USACE survey disks and access covers shall be stamped using 3.17-millimeter (1/8-inch) steel dies. All stampings shall deform the disk surface by a minimum of 1 millimeter (0.039 inch).

a. Pedestal in Soil. For a monument pedestal in soil (Figure 4-1a), a 1.2-meter (4-foot) square concrete footing shall be constructed below the frost line. The thickness of the footing will be 0.6 meter (2 feet). A 25.4-centimeter (10-inch)-diameter steel pipe pedestal filled with concrete will be attached to the footing with five #4 ribbed rebars placed on 10-centimeter (4-inch) centers embedded in the footing and pedestal for a minimum of 50 centimeters (20 inches). A centering device as shown in Figures 4-2 and 4-3 shall be placed in the center of the pedestal. A protective cover and casing of 45.7-centimeter (18-inch)-diameter steel pipe shall be placed over the pedestal and extended from the top of the footing to approximately 1.22 meters (4 feet) above the ground surface.

b. Pedestal on Rock. For a control monument on rock, the construction is similar to the construction for a control monument in soil as illustrated in Figure 4-1b. All fractured and weathered material shall be removed from the rock. Then the rebars shall be epoxy grouted into the top of sound rock with five #4 ribbed rebars on 10-centimeter (4-inch) centers. The rebar shall be epoxy grouted into the rock for a minimum distance of 50 centimeters (20 inches) and should extend into the bottom of the pedestal at least 25 centimeters (10 inches). The protective covering, casing, pedestal, and centering device will be constructed in the same manner as a control monument in soil.

c. Centering Devices. The forced centering device shown in Figure 4-2 shall be installed in the top center of the instrument pedestal. The bottom of the centering device shall be embedded 5.7 centimeters (2.25 inches) in the concrete. The forced centering device shown in Figure 4-3 attaches to the base of the instrument and forces the instrument to center on the pedestal device.

d. Structure Insert. A structure insert is grouted in the existing concrete structure at selected locations (Figure 4-4). The top surface is rounded to provide a point for precise leveling. The center is tapped and threaded to fit a standard prism 5/8-inch by 11-inch thread. A 5/8-inch brass plug or bolt should be screwed into the threads when not in use. The insert shall be made from 1-1/4-inch hex stainless steel stock. The structure insert is illustrated in Figure 4-4.

4-3. Naming Horizontal Control Monuments. Intelligible names should be assigned as primary identifiers of horizontal control

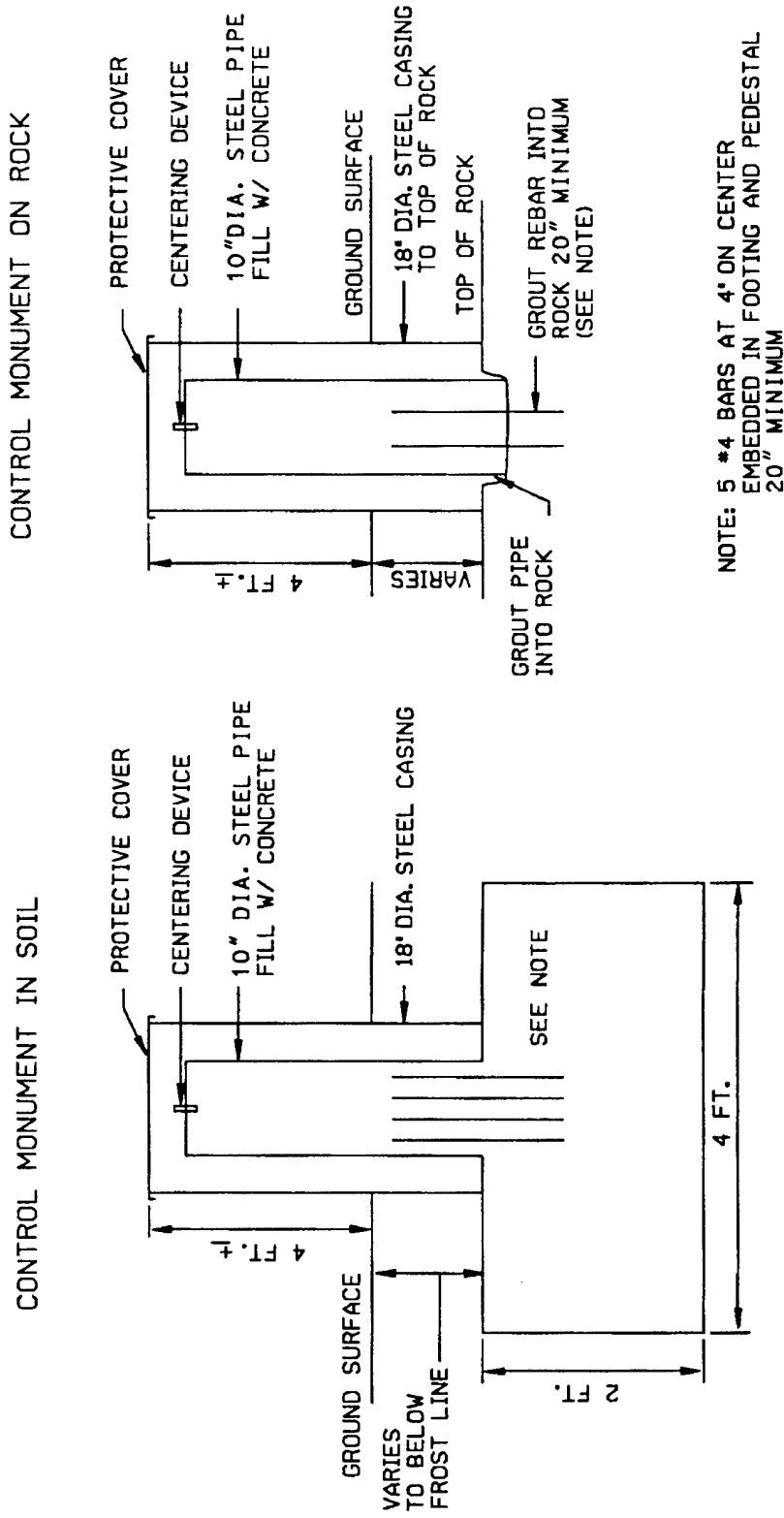

NOTE: 5 #4 BARS AT 4' ON CENTER  
 EMBEDDED IN FOOTING AND PEDESTAL  
 20" MINIMUM

Figure 4-1. Instrument pedestal

NOTES:

1. DIMENSIONS ARE IN INCHES
2. TOLERANCE ON .xx ± .01,  
 .xxx ± .005
3. TO BE MADE FROM B21 ALLOY  
 1 1/2 ROD STOCK
4. STAMP SERIAL NUMBER HERE,  
 1/4 x 1/4, STARTING WITH  
 NUMBER 1

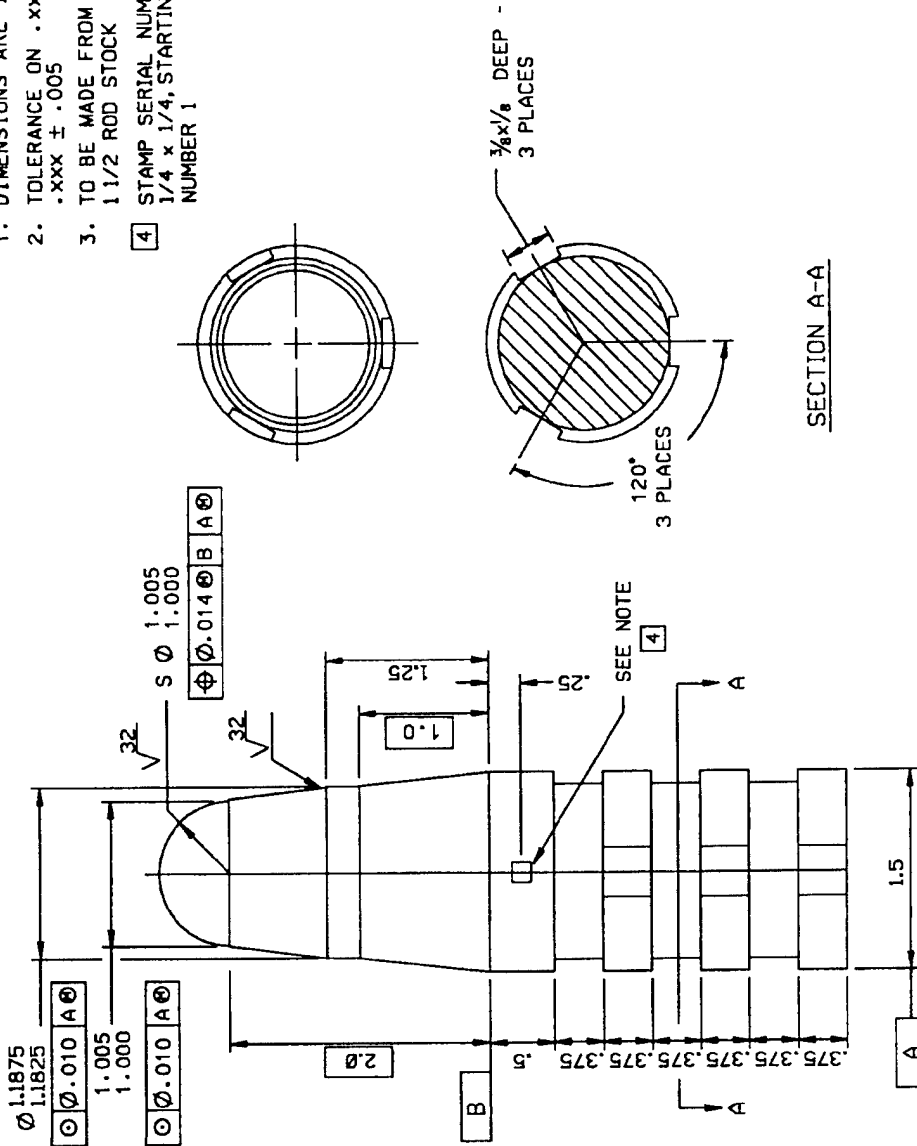

Figure 4-2. Instrument pedestal forced centering device

NOTES:

1. DIMENSIONS ARE IN INCHES
2. TOLERANCE ON .xx ± .01,  
.xxx ± .005
3. TO BE MADE FROM B21 ALLOY -  
2" ROUND STOCK
4. FOR ASSEMBLY - USE 1/4-20  
UNC-2A, 1/4" LONG SET SCREW
5. ALL MACHINE SURFACES ARE  
 $\sqrt{32}$

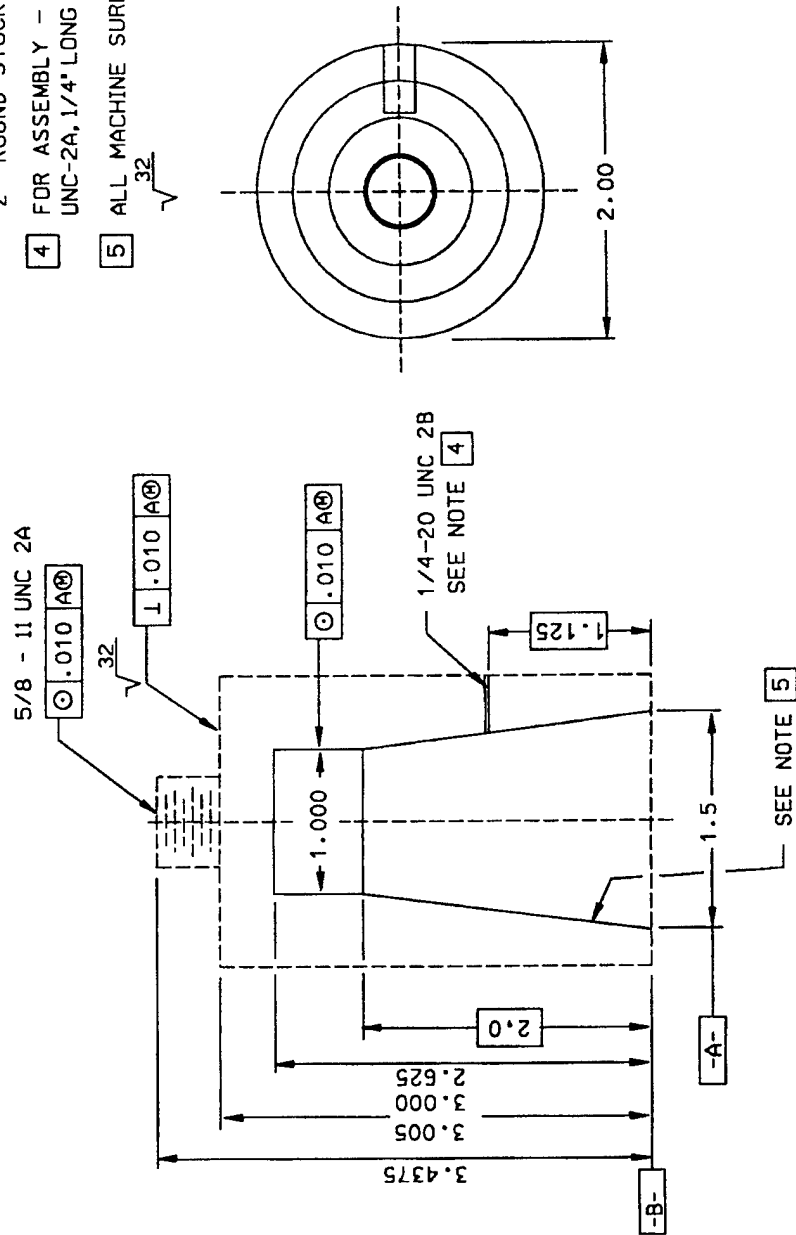

Figure 4-3. Instrument forced centering device

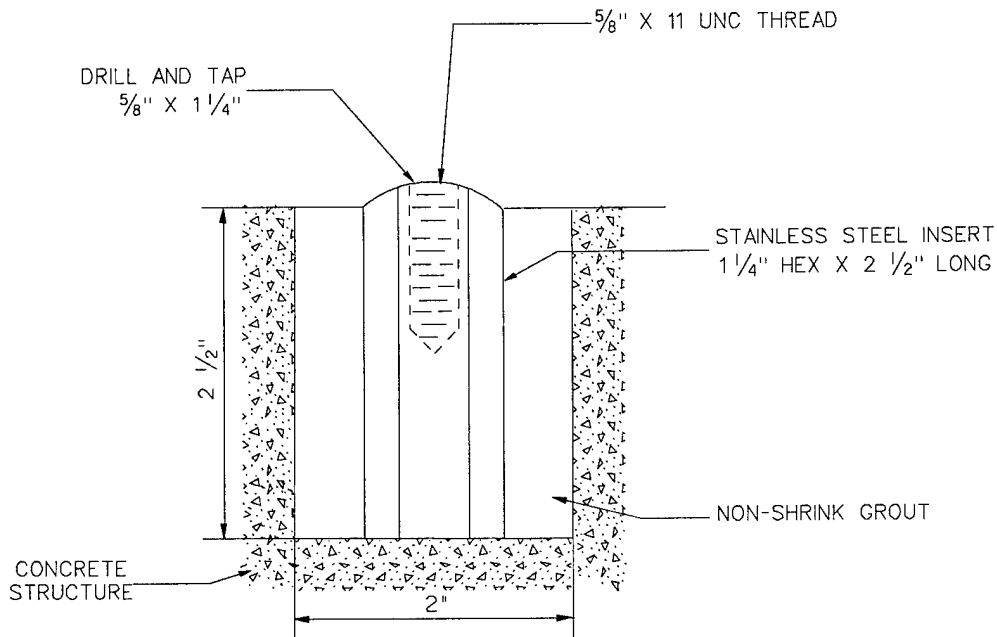

Figure 4-4. Structure insert

points. A properly chosen station name should in itself be descriptive and/or indicative of the general location of the respective horizontal control point.

a. Maximum Character Length. The name of a monumented horizontal control point should be concise, being limited in length to a maximum of 30 characters.

b. Monumented Point. In addition to the "year mark set" another date is associated with every survey point whether it is a monumented horizontal control point or an unmonumented recoverable landmark. This additional information, referred to as the "year established," is the year in which observations were first performed for the purpose of determining the position of the horizontal control point. The "year established" should also reflect the year in which the original description of that control point was prepared. The "year established" and "year-mark-set" of a monumented horizontal control point are often identical. Additional information on network design, geometry, and connections is located in a separate engineering manual that is currently in preparation.



c. Unmonumented Point. Another type of horizontal control point is an unmonumented recoverable landmark such as a flagpole or church spire. The name of a horizontal control point of this type must be sufficiently descriptive in order to identify the respective landmark (frequently a specific feature of the landmark). For this reason, the name of this type of control point is usually lengthy. The length of a station name, including all imbedded blanks, should be limited to 30 characters. The same limit applies to the name or designation of a reference mark (RM) or azimuth mark (AZ MK). Accordingly, the name of every horizontal control point, as well as the name or designation of an RM or AZ MK, should be abbreviated so that it does not exceed 30 characters.

d. Abbreviating Lengthy Names. When a lengthy name of a horizontal control point is contracted to the 30-character limit, the abbreviation and/or editing of the station name should be accomplished with due regard to the following fact. The names of reference and azimuth marks should be formed by appending the symbols RM 1, RM 2, ..., RM 13, etc., and AZ MK (possibly AZ MK 2, AZ MK 3, etc.) to the station name of the control point. For this reason, the name of a horizontal control point that has peripheral reference marks and/or azimuth marks may have to be further contracted to 24 characters (possibly less). This contraction is necessary to allow the reference and azimuth mark names to conform to the 30-character limit. The abbreviation "ECC." (for eccentric) should never be stamped on a disk. Each standard disk utilized to mark a horizontal control point should be stamped with the station name, year set, and organization (District) designated on the marker. Each recorded station, which is re-marked, should be stamped with the original name of the station, the original date of establishment, and the year in which it is reset. All information imprinted on any disk used for station and reference marks should be stamped with 3.17-millimeter (1/8-inch) dies.

4-4. Reference and Azimuth Marks. Reference and azimuth marks should be constructed similar to their respective control monuments. Type F and Type G monuments (Figures 3-7 and 3-8) may be used as reference and azimuth monuments. However, these types of marks need only extend a minimum of 91 centimeters (3 feet) below natural ground. In areas having permafrost, marks should be anchored about 60 centimeters (2 feet) in the permafrost. Reference marks and azimuth marks should be identified by standard USACE disk markers with an arrow as the survey point symbol created by stamping a "V" on either end of the line indicating the center. The markers are set in such a way that the arrow points toward the respective horizontal control point. Three reference marks should be established for first- and second-order control networks in the immediate vicinity (less than 30 meters (100 feet)) of a monumented horizontal control point. The reference marks may be natural landmarks or manmade monuments. In addition, if a well-defined permanent object (natural or manmade) is not available, one azimuth mark shall be established for

first- and second-order control networks not less than 0.4 kilometer (0.25 mile) away when feasible. This will provide an azimuth reference point that is visible from ground level at the horizontal control point. Azimuth and reference marks are not required for third-order networks or when adjacent control points have intervisibility and are not closer than 0.4 kilometer (0.25 mile). Vertical and horizontal control type monuments may be used for reference and azimuth marks.

a. Naming Reference Marks. The originally established reference marks of a horizontal control point should be assigned sequential numbers (for example, NO 1, NO 2, etc). Any subsequently established reference mark should be assigned the next unused number in the sequence, even if one or more of the previously established reference marks may have been destroyed. The standard practice is to stamp the name of the horizontal control point to which a reference mark refers above the arrow (station designation) that appears in the center of the disk marker. The number of the reference mark, NO 1, NO 2, etc., is stamped immediately below the arrow. The year in which the reference mark was set is stamped in the block marked "year." The name or designation of a reference mark (RM) must not exceed 30 characters in length. It should normally consist of the name of the horizontal control point to which the respective RM belongs with the symbol RM 1, RM 2, ..., RM 13, etc., appended for reference marks NO 1, NO 2, ..., NO 13, etc. No additional information should be added to the name of an RM, except when the numbering system described above has not been followed, or when two or more reference marks associated with a horizontal control point have identical names. In this case, the "year mark set" should be further appended to make the respective names unique (for example, KELLEY RM 1974 and KELLEY RM 1975, if the RM set in 1975 has not been stamped "NO 2"). Considering that the total length of RM name must not exceed 30 characters, the name of the horizontal control point must itself be limited to 24 characters to allow for any appended symbols (RM 1, RM 2, etc.). The name of the horizontal control point must be taken as it appears on the disk, except for possible further abbreviation and/or editing that may be required. If old reference marks are found to be in poor condition, they should be destroyed and reset. The new reference mark should be numbered with the next consecutive unused number, regardless of the existence or absence of any of the reference marks.

b. Naming Azimuth Marks. The same procedures used to name reference monuments shall be used for azimuth marks. If more than one azimuth mark is involved, a number should be assigned and stamped on the azimuth disk marker. Symbols such as AZ MK should be appended to the control point designation when only one azimuth mark is present. Symbols such as AZ MK 2, AZ MK 3, etc., should be appended when two or more azimuth marks are installed. The complete designation station name plus AZ MK 2, etc., shall not exceed the 30-character limit.

c. Other Agency Monuments. Occasionally, an existing monumented survey point of another agency may be used for a reference mark or, more frequently, for an azimuth mark. Such a survey point must be treated as a control point. If it can be positioned, or if its geodetic position is available from other sources, this data should be provided in the description; otherwise, give its name or designation.

4.5 Three-Dimensional Monuments. With the increasing use of space system measurement techniques, such as the Navstar Global Positioning System (GPS), it is important that station markers be stable in all three dimensions (Three-Dimensional Monuments). When selecting sites for high precision primary networks or for deformation monitoring, it is recommended that soil and geotechnical specialists be consulted. The type monument best suited for a given condition will depend on factors previously discussed. To meet the requirements of permanent and stable monumentation, the three-dimensional monuments should be metal disks set in rock outcrops or large masses of concrete, Type C (Figure 3-3), and deep-driven rod monuments, Types A and B (Figures 3-1 and 3-2). The name or designation of individual monuments used for both horizontal and vertical control networks of third order or better should be limited to 25 characters. Neither the "year established" nor the "year mark set" should appear as a part of the station name. Designation criteria for vertical control monuments, as outlined in paragraph 3-3, should also be used for all three-dimensional monuments.

4-6. Marks of Other Organizations. If a satisfactory horizontal control monument of another organization is found at the project site in good condition, it may be used without alteration as the station mark of a new USACE Survey Monument. Reference marks and azimuth marks should be placed, as necessary, to bring the station installation up to the requirements of this manual. In case the existing mark of the other organization is not in good condition for a station mark, a new station mark should be established in the vicinity, and the mark of the other organization should be used as an extra reference mark. The stamping of additional marks should be done as indicated in this manual. Care should be taken not to displace a mark of another organization in horizontal position, or even in vertical position if there is a possibility that it could be used as a bench mark. The mark should not be altered without permission from the organization that established it.

4-7. Witness Posts. In order to aid in preservation and to serve as a means of easy recovery of monuments being established, a witness post should be set adjacent to the monument or near one of the reference marks at each station. This post should be 1.8 meters (6 feet) in length and be set to a minimum of 1 meter (3 feet) above the ground surface. The post should have the standard witness post sign attached (Figure 3-11). Witness posts will be set for monuments of third-order accuracy and above, established along public highways, in rural districts, along the

EM-1110-1-1002

14 Sep 90

rights-of-way of railroads, and along the shorelines of rivers and lakes. They need not be set for monuments established along business streets, in residential sections of cities, on the grounds of a school or a church, in cemeteries, in cultivated farmlands, or on bare mountain tops. For survey monuments established below grade or in cultivated fields, the post shall be set at a reference mark.

CHAPTER 5

BOUNDARY MONUMENTS

5-1. Installation of Boundary Monumentation. The installation and the types of monuments used for boundary monumentation should be under the control of the Real Estate Division. Site conditions, the value of the property, the legal description of the property, encroachment possibilities, and local laws and customs are some factors that dictate the economics and practicality of where and what type of monument should be installed. In the absence of specific instructions from the Real Estate Division, the criteria presented in this chapter are offered as guidance.

5-2. Selection of Monument Type Based on Local Site Conditions. The type of monument to be used for boundaries is a function of the site conditions. The different monuments that may be used to mark boundaries are identified in Table 5-1. Construction details are illustrated in Figures 3-1, 3-3, 3-7, and 3-8. All boundary monuments shall be constructed with the standard USACE survey disk.

Table 5-1

Site Conditions and Monument Types for Boundary Control

<u>Site Conditions</u>	<u>Monument Types</u>
Rock outcrops, large boulders, bedrock concrete structures (more than 5 years old)	C
Granular soils (sand and gravel)	F,G
Glaciated soils (till)	F,G
Fine-grained soils (silts and clays with high bearing strengths)	F,G
Fine-grained soils (silts and clays with low bearing strengths)	G
Construction fill (disturbed earth)	G
Permafrost	G
Marsh	A
Subsidence area	A

14 Sep 90

5-3. Construction and Installation Procedures. The standard USACE survey boundary disk shall be used as boundary monuments constructed as Type C, Type F, or Type G. All USACE survey disks shall be stamped using 3.17-millimeter (1/8-inch) steel dies. All stampings shall deform the disk by a minimum of 1 millimeter (0.0394 inch).

a. Monuments in Concrete or Rock. Refer to Type C monument installation in paragraph 3-2c.

b. Drive-in Aluminum Rod Monuments. The Type F monument is illustrated in Figure 3-7 and constructed as outlined in paragraph 3-2f.

c. Poured-in-Place Concrete. Monuments that are poured in place should be constructed as illustrated in Figure 3-8 for a Type G monument.

5-4. Naming Boundary Monuments. Monuments may be identified by code numbers or alphanumeric symbols as outlined in paragraph 4-3. Monuments may be identified by a name or a designation of a specific corner. All monuments shall be constructed with a USACE survey disk (Figure 3-10) and shall have the right of way (R/W) or boundary stamped thereon.

5-5. Reference Monuments. A reference monument is an accessory and is employed in situations where a regular permanent monument locating the site of a corner cannot be established. Also, reference monuments are required in areas where the corner monument would be liable to destruction and/or bearing trees or nearby bearing objects are not available. When the true point for a corner lies within an unimproved roadway, in such a place as to interfere with travel, an iron rod, pin, or Type F monument shall be buried in the ground at the true corner point. If bearing trees or nearby bearing objects are not available, at least two reference monuments should be established at suitable places outside of the roadway. Allowance should be made for grading, cuts, fills, or other road improvement when placing the reference monuments. If the surface of the roadway is gravel, macadam, or bituminous-topped, approval from the proper authorities should be obtained before placing the point. In the case of a hard surface, a survey disk or "P-K" nail should be placed at the true point. Two reference monuments ordinarily suffice in public survey practice, but four may be employed if desirable. When two monuments are used, they are usually placed equidistant and in opposite directions from the true point. An acceptable alternative is the placement of the monuments so that the lines connecting them with the corner point are approximately perpendicular to each other. If four monuments are used, they should be placed in opposite directions in each of the four quadrants. When the true point is in an engineered road with established right-of-way lines, it is desirable to locate the reference monument on the intersection of those right-of-way lines and the true property

lines that establish the corner point. Appropriate identification, as outlined in paragraph 4-4, shall be utilized.

5-6. Witness Trees and Corners. Each property corner, reference monument and witness corner shall be witnessed by at least three healthy witness (sometimes called "tie" or "reference") trees a minimum of 15 centimeters (6 inches) in diameter and at least 1.2 meters (4 feet) tall. When possible, all witness trees shall be blazed, facing the corner set they reference. Witness trees must also be marked with an x facing the corner at an elevation height of 120 to 150 centimeters (4 to 5 feet) above the ground. Care should be taken to cut the cross to a sufficient depth to leave a set of permanent narrow marks forming a cross with lines about 25 centimeters (10 inches) long. Witness trees to witness corners should be scribed with the symbols W.C. (witness corner). Tree blazing and marking should not be done without the specific permission of the landowner.

a. Witness/Reference/Tie Distance Measurement. All distance measurements shall be horizontal and taken to the center of the tree.

b. Witness/Reference/Tie Directions. The bearing of each distance measurement shall be observed and recorded. A compass is sufficiently precise for this measurement.

c. Witness Corner Monuments. Where physically impossible to set a monument, a witness corner(s) should be set on each converging boundary line, no closer than 150 centimeters (5 feet) from the corner point. All witness corners, identified as W.C., shall be marked with a USACE disk. The distance to the true corner shall be stamped on the disk, along with an arrow indicating the direction.

d. Natural or Physical Monuments. Natural monuments are permanent objects that are works of nature, such as streams, rivers, ponds, lakes, bays, trees, ledges, rock outcrops, and other definitive terrestrial features. A tree standing at a corner may be marked only when permissible. Care should be taken to cause only superficial damage to the tree. Blazing should penetrate the bark and leave an open cut no wider than 8 centimeters (3 inches) and no longer than 25 centimeters (10 inches). Corner trees should be marked with four-way blazes (blazed on all four sides). Trees on a boundary line (line trees) should be face blazed with one hack above and one hack below, on opposite sides of the tree, along a line 120 to 150 centimeters (4 to 5 feet) above the ground. Permission should be obtained before marking any trees. Selected trees within 90 centimeters (3 feet) of the line should be marked with three hacks facing the line and face blazed on opposite sides of the marks 120 to 150 centimeters (4 to 5 feet) above the ground.

5-7. Boundary Marker Sign. In order to aid in the preservation and to serve as a means of easy recovery of newly established

EM 1110-1-1002  
14 Sep 90

monuments, a 4- by 4-inch wooden post or equivalent marker shall be set adjacent to the station monument or near one of the reference marks of each station (preferably at the station mark). This post should be a minimum of 170 centimeters (5.5 feet) in length and should be set to project a minimum of 90 centimeters (3 feet) above the ground surface. The post should be painted white with a marker having a legend of black letters attached as indicated by the boundary line or easement line markers shown in Figure 3-11.



CHAPTER 6  
DOCUMENTATION

6-1. Monument/Marker Documentation. Each permanent monument constructed or recovered should be documented by completing DA Form 1959, Description or Recovery of Horizontal Control Station, illustrated in Figure 6-1.

a. Monument Name. The monument name shall conform to that outlined in the manual and as stamped on the disk. Longitude and latitude shall be scaled from maps for marks with vertical control only. The order of accuracy shall be determined as defined by Federal Geodetic Control Committee specifications. Monument type shall be designated as outlined by this manual. Additional instructions on the completion of DA Form 1959 are located on the back of the form.

b. Computer Data Base Storage. For those using computer data bases for storage and retrieval of control data, a suggested format is illustrated in Figure 6-2. Use of this format is optional and modification of data elements is allowed to meet local needs. Additional instructions on the use of this format are located on the back of Figure 6-2.

EM 1110-1-1002  
14 Sep 90

S A M P L E

COUNTRY United States		TYPE OF MARK A (23ft deep)		STATION Q-11-1-89	
LOCALITY Shelby Co., TN		STAMPING ON MARK Q-11-1-89		AGENCY (CASE IN MARKS) Corps of Engineers Memphis District	
LATITUDE 35-21-14.05966		LONGITUDE 89-57-09.62619		ELEVATION (FT) 272.648 XXX	
INORTHING (FEET) 395,295.637 XXX		EASTING (FEET) 790,128.928 XXX		GRID AND ZONE NAD 83 Lambert - Tennessee	
INORTHING (METERS) 3,916,554.324 XXX		EASTING (METERS) 776,914.451 XXX		GRID AND ZONE UTM - 15	
TO OBTAIN Tennessee		GRID AZIMUTH, ADD		TO THE GEODETIC AZIMUTH	
TO OBTAIN UTM-15		GRID AZ. (ADD/SUB.)		TO THE GEODETIC AZIMUTH	
OBJECT		AZIMUTH OR DIRECTION (GEODETIC/GRID)		GEOD. DISTANCE (FEET)	
Q-11-2-89		93° 56' 05.5		1277.040	
		BACK AZIMUTH		GRID DISTANCE (METERS) (FEET)	
		93° 56' 14.5		TN-1277.002ft UTM-389.450m	

First Order horizontal control mark was established by the Memphis District Corps of Engineers in November 1989. To reach the station from the intersection of U. S. Hwy 51 and Shelby Road, go West on Shelby Rd. for 2.8 miles to Shake Rag Road and the station on the left. The station is 49.0' SE of the intersection of Shelby and Shake Rag Road, 35.2' NE of a power pole, 58.4' W of the C/L of a gravel drive over a culvert leading to the residence at the site, and 2' N of a witness post. The disk is 0.7' below the surface of the access cover. The access cover is 0.2' below ground level and 0.5' below road level. The disk and access cover are stamped Q-11-1-89.

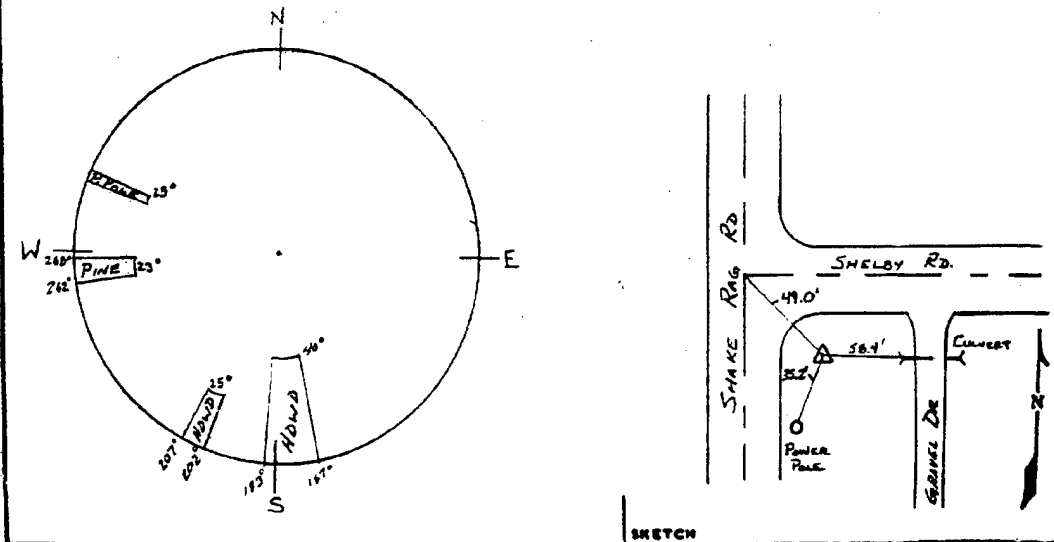

DA FORM 1959 REPLACES DA FORMS 1959 AND 1959, 1 FEB 57, WHICH ARE OBSOLETE. DESCRIPTION OR RECOVERY OF HORIZONTAL CONTROL STATION For use of this form, see TM 5-237; the proponent agency is TRADOC.

Figure 6-1. Description or Recovery of Horizontal Control Station Form (Continued)

S A M P L E

NOTES ON COMPLETION OF FORM

1. **GENERAL:** This form may be used in the field or, as an office form to record and publish positions, descriptions, and related data.

2. **FIELD USE OF FORM:** The information required should be obtained and recorded *AT THE STATION SITE*. The field engineer should fill in only the information available and applicable to field use. In general, the geographic and grid positions, azimuths, distances, and elevations should not be filled in at field level except when the information is required for an immediate specific purpose.

a. **ORIGINAL DESCRIPTION OF NEW STATION:** The type of mark used for the station, reference marks, and azimuth marks, and a description of each must be given in the text of the description. If a disk is used, the identity of the agency whose name is cast in the disk and all of the letters and numbers stamped on the mark which identify the organization establishing or setting the mark should be given. In many areas the use of disks is not desirable because of their loss, due to vandalism or superstition. Less conspicuous marks should be used under these conditions. This requires exact statements of the character of the marks. Information for all marks as to the elevation above or below ground and approximate elevation above or below nearby prominent features is important. At least three measurements within .01 foot should be made from the station to any permanent marks, features, or structures that would permit re-locating the spot where an instrument was centered.

Good judgment should be exercised as to how far these measurements should be made. It is recommended that they be made to items which are not in the immediate vicinity of the station. Angles should also be turned to these items, particularly where no azimuth mark or marks have been established.

b. **VIEW:** Provide information on height of tower or stand used in occupying or establishing the station and information on view from a normal tripod, i.e., a 50-foot tower was used at the station; view from a tripod height is clear to the south and east but is obstructed by rise in ground (by 50 foot trees) to the north and west.

c. **PHOTOGRAPHIC IDENTIFICATION:** Provide when possible, two measurements from the station to natural or cultural features which might be visible on aerial photography and a description of the terrain. If photographs are available identify the station thereon and note estimated accuracy of the identification.

d. **NOTES ON RECOVERED STATIONS:** A diligent search should be made for *ALL* previously established stations in the vicinity and no station should be reported as destroyed unless conclusive evidence of destruction is present. A statement of the diligence of the search and reason for the non-recovery of a previously established mark is required. If the spot where a station mark was located can be reproduced by measurement given in the description, the station is not destroyed. The reproduced spot should be tied in by azimuth and distance and the estimated accuracy of the reproduced location given. If a new mark is set in the exact location of a previously established but destroyed mark, the designation of the station should be identical with the original with only a new date added to its designation. If a new disk is set in the approximate location of the old station, the name should be preserved but the number "2" and a new date should be added.

(DESCRIBED) (RECOVERED) BY	
Carol A. Waite	
PROJECT	
GPS 12 - Big Creek	
DATE	FIELD BOOK
Nov 1989	N/A

© U.S. Government Printing Office: 1985-491-003/45168

Figure 6-1. (Concluded)

S A M P L E

MONUMENT/MARKER DOCUMENTATION

1. Name of Monument Q-11-1-89
2. Quad Sheet MILLINGTON
3. City (nearest city, town, community, etc.) SLOANVILLE
4. County SHELBY
5. State TN
6. River \*
7. River Mile \*
8. Lake/Reservoir \*
9. Date established 2 NOV 89
10. Elevation 272.648
11. Latitude 35-21-14.05966
12. Longitude 89-57-09.62619
13. Datum Vertical: NGVD 29 Horizontal: NAD 83
14. Order of Accuracy Vertical: 3rd Horizontal: 1st
15. Monument Type A Type of Rods \* 23 ft.
16. Highway/Road \* SHELBY
17. Section \*
18. Township \*
19. Range \*
20. Baseline Station \*
21. Levee District \*
22. Levee Mile Post (LMP) \*
23. Railroad \*
24. Bayou \*
25. Ditch/Creek \* BEAR
26. Pumping Station \*

\* - If applicable

27. Description: TO REACH THE STATION FROM THE INTERSECTION OF US HWY 51 AND SHELBY RD, GO WEST ON SHELBY RD FOR 2.8 MI TO SHAKE RAG RD AND THE STATION ON THE LEFT. THE STATION IS 49.0' SE OF THE INTERSECTION OF SHELBY AND SHAKE RAG RD, 35.2' NE OF A POWER POLE, 58.4' W OF THE C/L OF A GRAVEL DRIVE OVER A CULVERT LEADING TO THE RESIDENCE AT THE SITE, AND 2' N OF A WITNESS POST. THE DISK IS 0.7' BELOW THE SURFACE OF THE ACCESS COVER. THE ACCESS COVER IS 0.2' BELOW GROUND LEVEL AND 0.5' BELOW ROAD LEVEL. THE DISK AND ACCESS COVER ARE STAMPED Q-11-1-89

Sketch

Figure 6-2. Suggested format for monument/marker documentation (Continued)

GUIDELINES ON COMPLETION OF FORMAT

1. General. This format may be used in the field offices to record positions, descriptive and related data, or for direct entry to a database program.
2. Use of Format. Descriptive data and other information available in the field should be recorded at the station site. All other applicable data should be added to the format as this information becomes available. Information equivalent to data items 1 thru 5, 9 thru 15, and 27 should be completed for each mark. All other items should be completed only as applicable.
  1. The name or station designation of the mark.
  2. The name of the 15-minute quad where the mark is located.
  3. The name of the city, town, or community near the mark.
  4. The county in which the mark is located.
  5. The state in which the mark is located.
  9. The month, day, and year the mark was established.
  10. The elevation of the top of the disk or rod of the mark. For horizontal-only marks, the elevation should be interpolated to the nearest half meter.
  11. The exact latitude (at least three decimal places) of mark. For vertical-only marks, the latitude should be scaled to the nearest second.
  12. The exact longitude (at least three decimal places) of the mark. For vertical-only marks, the latitude should be scaled to the nearest second.
  13. The datum surface to which the horizontal and vertical positions of the mark are referenced.
  14. The order and class of accuracy to which the horizontal and vertical positions were established. State if scaled or interpolated.
  15. The single letter designation of the monument type. If metal rods, pipe, or rebar were used, state the depth to which they were driven.
  27. The text of the description shall include, but is not limited to the following.
    - a. A one-paragraph narrative providing specific directions on how the monument may be reached from a readily locatable landmark, such as a public building in a nearby town or the crossroads of prominent highways.
    - b. At the station site, pinpoint the location of the mark with distance and direction from at least three reference objects in the immediate vicinity.
    - c. Vertical reference should be provided by giving the mark's distance above, below, or level with a nearby reference object or ground surface.
    - d. The distance and direction to the mark from the witness post should be provided.
    - e. If disk is used, provide the identity of the agency whose name is cast in the disk and all the letters and numbers stamped on the disk that identify the name of the mark and the organization setting it (i.e. the exact stamping on the disk).

Figure 6-2. (Concluded)