

NASA (TECHNICAL NOTE)

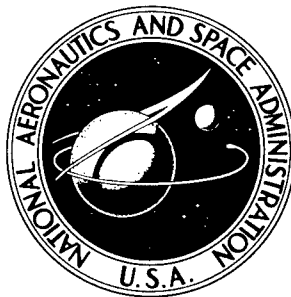

NASA TN D-3511

B064973

NASA TN D-3511

N66-30180  
CFSTI

# AMPTIAC

**DISTRIBUTION STATEMENT A**  
Approved for Public Release  
Distribution Unlimited

**COLD CONSOLIDATION OF METAL  
PLUS DISPERSOID BLENDS FOR  
EXAMINATION BY ELECTRON MICROSCOPY**

by *Gustav Reinhardt*, *Walter S. Cremens*, and *John W. Weeton*

*Lewis Research Center*

*Cleveland, Ohio*

20020326 081

NASA TN D-3511

COLD CONSOLIDATION OF METAL PLUS DISPERSOID BLENDS  
FOR EXAMINATION BY ELECTRON MICROSCOPY

By Gustav Reinhardt, Walter S. Cremens, and John W. Weeton

Lewis Research Center  
Cleveland, Ohio

**Reproduced From  
Best Available Copy**

NATIONAL AERONAUTICS AND SPACE ADMINISTRATION

---

For sale by the Clearinghouse for Federal Scientific and Technical Information  
Springfield, Virginia 22151 - Price \$2.00

COLD CONSOLIDATION OF METAL PLUS DISPERSOID BLENDS  
FOR EXAMINATION BY ELECTRON MICROSCOPY

by Gustav Reinhardt, Walter S. Cremens, and John W. Weeton  
Lewis Research Center

SUMMARY

*Start*  
An investigation was undertaken to determine the feasibility of high-energy-rate compaction as a means of consolidating powder blends used in the preparation of dispersion-strengthened alloys. *All* The techniques produced samples of sufficient density (greater than 85 percent of theoretical density) to be examined with an electron microscope. An advantage of the methods studied is that consolidation was accomplished without application of high temperature, and thus agglomeration that might result through diffusion or chemical reaction may be avoided.

Three techniques were investigated: a cartridge-actuated compaction press, a Dynapak press, and a direct-contact sheet explosive. The cartridge-actuated compaction press proved to be a practical laboratory apparatus that readily consolidated nickel-base blends. Hydrogen cleaning prior to consolidation and annealing of the consolidated specimens improved the particle contrast of the micrographs, apparently without causing appreciable agglomeration of the dispersoid. Particles as fine as 0.01 micron were discernible in the microstructures. This particle size is within the range considered desirable for dispersion strengthening. A tungsten-base blend was also compacted with a slight modification of the cartridge-actuated compaction press. In a limited number of tests, the Dynapak and the direct-contact sheet explosive methods proved to be effective means of consolidating powder blends. *to p. 26*

INTRODUCTION

The desired microstructural parameters of a dispersion-strengthened material are generally recognized to be a dispersoid particle size of a few hundredths of a micron and an interparticle spacing of approximately 1 micron or smaller. Powder metallurgy methods have been studied extensively in relation to the fabrication of alloys having these

desired microstructural parameters. Perhaps the most widely investigated procedure has been mechanical mixing of metal and oxide powders and consolidation of the mixture by standard powder metallurgy techniques. Mechanical mixing is simple in principle and offers broad freedom in the choice of dispersion systems; however, results reported to date with mechanical mixing have seldom shown interparticle spacings of less than 1 micron.

Some of the early workers (refs. 1 and 2), attempting to apply mechanical mixing methods, utilized oxide powders for the dispersoid having average particle sizes in the range 0.001 to 0.01 micron, but they used metal powders for the matrix that ranged in size from 1 to 10 microns or larger. More recently, investigators also recognized that metal powders of less than 1 micron had to be used in order to achieve the desired sub-micron interparticle spacing (refs. 3 to 6). Using a statistical approach with known topological relations, Cremens (ref. 7) derived an equation that relates the minimum achievable interparticle spacing to the volume fraction of dispersoid and to the starting powder sizes of both the matrix and the dispersoid phases. The equation was derived on the assumption of an ideal condition of random mixing (perfect blending). With less than perfect blending, the dispersoid particle size and interparticle spacing are greater than those predicted by the equation. This equation (ref. 7) confirmed the reasoning that both the metal and oxide powders should have submicron particle sizes if the desired fine microstructural parameters are to be achieved.

Experiments conducted at the Lewis Research Center (ref. 3), as well as those conducted by other investigators (refs. 5 and 6) indicated that blends made with metal particles in the 1- to 10-micron size range had interparticle spacings within an order of magnitude larger than those predicted from the equation noted in the preceding paragraph; however, finer spacings are desired.

In many of the attempts to obtain finer spacings through the use of submicron powders, however, the resultant fabricated alloys had coarse, agglomerated oxides and much greater interparticle spacings than predicted by the equation (refs. 6 and 8). Several causes have been postulated for this coarse structure, including the following: (1) The submicron particles may not blend well because they are held in clusters because of attractive forces associated with their high specific surface area. (2) Even if blending is successful and the particles are well dispersed, they may have a tendency to agglomerate when heat is applied during the subsequent processing because powders in a fine state of subdivision are less stable thermodynamically. (3) Generally, the finer powders have a higher impurity content and the impure particles may be less stable chemically at high temperatures. (4) Also, some mechanical aspects of the fabrication process, such as pressing or extrusion, have been considered as possible causes of agglomeration of the dispersoid particles.

In an attempt to study the causes of agglomeration, examination of the structures of

mechanically mixed and extruded billets proved of little value because of the large number of interacting variables in the blending and/or consolidation operations. Several earlier attempts were made to observe the structure subsequent to each principal operation, but these methods were not successful. These methods are described in the appendix.

In view of the shortcomings of the preliminary investigations (described in the appendix) it was apparent that a consolidation method was required that did not provide an opportunity for agglomeration to take place through thermally induced diffusion or chemical reactions. The specimens were further required to be of sufficient density to permit handling, polishing, and preparation for electron microscopy methods required to resolve the submicron particles. High energy rate consolidation methods were believed to be potentially able to fulfill these requirements. This investigation was, therefore, undertaken to determine whether such methods could be applied to consolidate various types of metal plus oxide powder blends to the required density without application of high temperatures.

Three compaction apparatuses were used: a 0.45-caliber cartridge-actuated compaction press (CACP), a Dynapak high-velocity press, and an explosive compaction facility. The tests were conducted with the CACP on nickel- and tungsten-base blends. The Dynapak was used on a nickel-base blend, and the sheet explosive on a tungsten-base blend. The methods were tried on as-blended powders, on blends which had been subjected to hydrogen cleaning, and on sintered specimens. Post-compaction-annealing techniques used to improve the clarity of electron micrographs of the compacted blends were also investigated.

## MATERIALS, APPARATUS, AND PROCEDURES

### Materials and Sample Preparation

The metal-oxide blends compacted by the various methods consisted of mechanically mixed submicron powders and also samples of composite powders produced by various manufacturers. The raw materials, compositions, and processing methods are listed in table I. Mechanical mixing processes typically used in the preparation of billet-size powder batches (about 2 lb) are outlined in the flow charts in figures 1 and 2. The process shown in figure 1 involves the use of a liquid as an aid in blending, while the process of figure 2 is a typical dry-blending operation. Stages at which 5-gram samples were taken are indicated in the flow charts. These samples were then consolidated for metallographic examination by one of the methods described in the INTRODUCTION. Processing steps relative to the production of billet-size batches are indicated by the

TABLE I. - AS-RECEIVED MATERIALS AND PROCESSING METHODS

(a) Mechanically mixed powder blends

Blend	As-received materials					Blending method
	Matrix metal	Average particle size of metal, $\mu$	Oxide	Average particle size of oxide, $\mu$	Volume of oxide added to metal, percent	
1	Nickel	0.064	Alumina	0.023	5.0	Dry rolled Liquid ↓ Dry (V-blender)
2	↓	.066	Thoria	.029	7.5	
3		.066	Thoria	.029	6.1	
4		.066	Alumina	.023	9.4	
5		.015	Alumina	.013	6.5	
6		Tungsten	.027	Thoria	.019	

(b) Composite powders

Blend	Matrix metal	Oxide	Method of blending	Average particle size, $\mu$	Manufacturer
7	Nickel	2 Volume percent thoria	Flash-dry solution	11.50	Curtiss-Wright
8	Tungsten	2 Volume percent thoria	Arc vaporization	.05	Vitro Corp. of America
9	Nickel - 15 percent molybdenum	4 Volume percent thoria	Spray-dry solution	1.60	Sylvania Electric Products

vertical flow steps, and the consolidation processing for metallography are indicated by the horizontal flow steps in figures 1 and 2. All processing, except where otherwise indicated, was conducted under inert atmosphere. Details of the processing steps in the production of billets using mechanical mixing, as shown in the flow charts, are discussed in the following paragraphs.

Precleaning of powders. - The oxide and metal powders were individually cleaned in flowing hydrogen, which was purified with a palladium diffusion purifier. The temperature used for cleaning the metal powder was kept below the point at which any sintering could be observed. For nickel this was 650<sup>o</sup> F, and for tungsten it was 1650<sup>o</sup> F. The oxide powders were heated at 1650<sup>o</sup> F.

Blending of powders. - In the liquid blending process, the metal and oxide powders

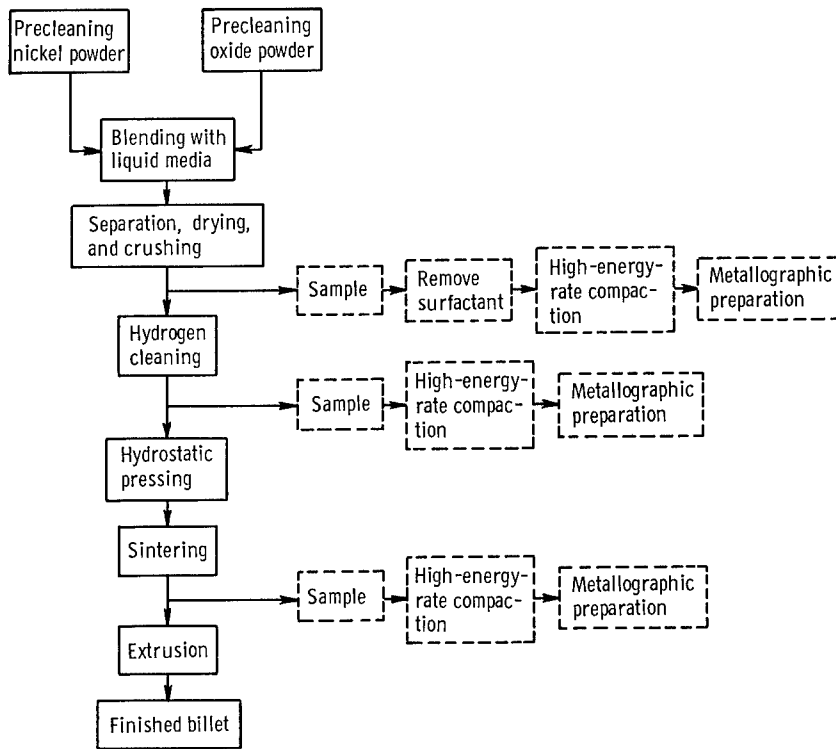

Figure 1. - Typical flow chart for preparation of dispersion alloy billets by using liquid blending methods. Solid lines denote billet processing operations; dashed lines denote sampling and consolidation for electron microscopy.

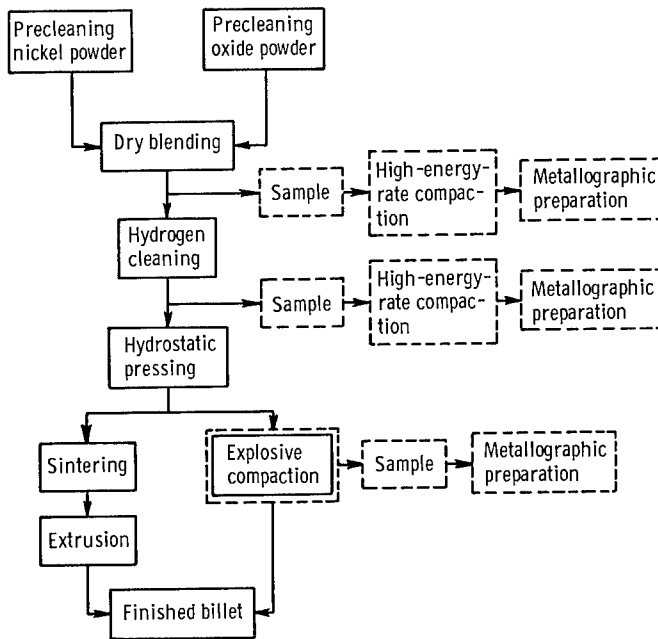

Figure 2. - Typical flow chart for preparation of dispersion alloy billets by using dry blending methods. Solid lines denote billet processing operations; dashed lines denote sampling and consolidation for electron microscopy.

were suspended in a liquid medium consisting of heptane with oleic acid added as a surfactant. The suspension was then blended with a homogenizing apparatus (Sub-Micron Disperser, Manton-Gaulin Mfg. Co.) and the liquid subsequently removed by vacuum filtration. The filter cake was then vacuum dried at temperatures up to 170<sup>o</sup> F and subsequently crushed to pass through a 40 mesh sieve.

Two methods of dry blending were used. The first method consisted of a combination of blending for 10 minutes in a twin shell V-blender with an attached agitator cage and then subsequent blending for 10 minutes in a high-speed rotary blender. The other method consisted of blending powders by rolling them in a 1-liter plastic jar containing 1/4-inch-diameter glass beads, at 60 revolutions per minute for a period of 24 hours.

Cleaning of powders. - After the blending operation, the powders were cleaned with flowing purified hydrogen at temperatures ranging from 950<sup>o</sup> to 1200<sup>o</sup> F for the nickel-base blends and at a temperature of 1600<sup>o</sup> F for the tungsten-base blend. As a result of the cleaning treatment, the nickel-base powders were sintered to a porous mass (35 to 40 percent theoretical density) and were then crushed to pass through a 40 mesh sieve.

Pressing of powders. - The cleaned powders were loaded into cylindrical rubber pressing bags, (2 to 3 in. diam) sealed, and evacuated. Hydrostatic pressing was generally carried out at pressures of 60 to 80 ksi. Pressed billets were nominally 60 to 70 percent of theoretical density.

Sintering of powders. - The pressed nickel-base billets were sintered for 4 hours in purified flowing hydrogen at 1900<sup>o</sup> F. The tungsten-base billet, which had been explosively compacted (in a manner to be described in the section Compaction with Sheet Explosive) was not sintered.

Sampling for high-velocity compaction. - As noted in the flow charts of figures 1 and 2, samples were removed from the billet-size batch of powder following several of the steps in the processing schedule. The samples taken after liquid blending were dried under vacuum at room temperature, crushed, and subjected to vacuum heat treatment at 950<sup>o</sup> F to remove all traces of the surfactant used in blending. All samples removed after cleaning were also crushed to pass through a 40 mesh sieve. The samples from either the explosively compacted or sintered billets were thin slices (approx 1/4 in. thick), which were saw cut from the end of the billets.

Blends produced by methods other than mechanical mixing. - In order to illustrate the applicability of the CACP method to dispersion alloys produced by methods other than mechanical mixing, samples of powders produced by three other methods were compacted and examined. These samples were furnished by the manufacturers, as noted in table I(b). The samples of composite powders represent experimental studies as do the other blends presented in this report and do not necessarily indicate the ultimate capability of the process involved to produce ideal dispersions.



The flash- and spray-dry methods indicated in table I are similar in that aqueous solutions of constituents are prepared and then quickly dried by a method that prevents segregation. Subsequently, the powders are reduced by hydrogen. The difference in the two methods is in the types of solutions and the drying methods used. Details of the two methods have been reported by B. Triffleman (ref. 9) and R. F. Cheney (Sylvania Electric Products, Inc.). In the arc-vaporization method, the constituents are vaporized in a high-intensity arc, and the matrix metal is subsequently reduced. The process has been described by J. D. Holmgren, J. O. Gibson, and R. Weidman (Vitro Laboratories).

### Compaction with Cartridge-Actuated Compaction Press

A sketch of the CACP used in this study is shown in figure 3. It is similar in design to that described by Stein, Van Orsdel, and Schneider (ref. 10).

The barrel, closures, and die projectiles and plugs were constructed of AISI 4340 alloy steel hardened to Rockwell C55. The barrel was designed, using thick wall pressure vessel theory, for safe operation at a static gas pressure of 50 000 pounds per square inch. A blowout rupture disk was included as an additional safety feature. In operation, the cartridges were loaded with a selected gun-powder charge, and a ram fitted with a gas check was forced into the cartridge. The metal powders to be compacted were weighed and lightly tamped into the die, which had been lubricated with a Teflon aerosol spray. Except as otherwise noted, the entire CACP apparatus was placed inside a dry box, and all loading operations were conducted under a protective argon atmosphere. After loading and sealing, the barrel was evacuated with a mechanical vacuum pump for a period of 10 minutes to insure a reasonably good vacuum (estimated to be about  $100\mu$ ). The cartridge was fired while the vacuum pump was operating.

Experience with the apparatus indicated that different nickel powder blends behaved somewhat differently in compaction but that the optimum compaction could be determined after a few trials. For specimens of the nickel-base powders, samples of about 1.75 grams were used to yield pellets about 1/16 inch thick. An initial compaction test was usually made with a cartridge loaded with 4.5 grains of Bullseye brand pistol powder. If the density of the pellet was too low, the gun powder charge was increased, generally in 0.5- or 1-grain increments. Too great a charge generally resulted in a delaminated pellet, but often a small delaminated piece was still usable for electron microscopy.

In certain tests where blends could not be compacted with the standard method, special techniques were developed. These methods involved the addition of ductile powders, such as pure nickel or copper in the following configurations: (1) a layer on top of the sample, (2) a precompact layer about the periphery, or (3) a layer com-

6705/713

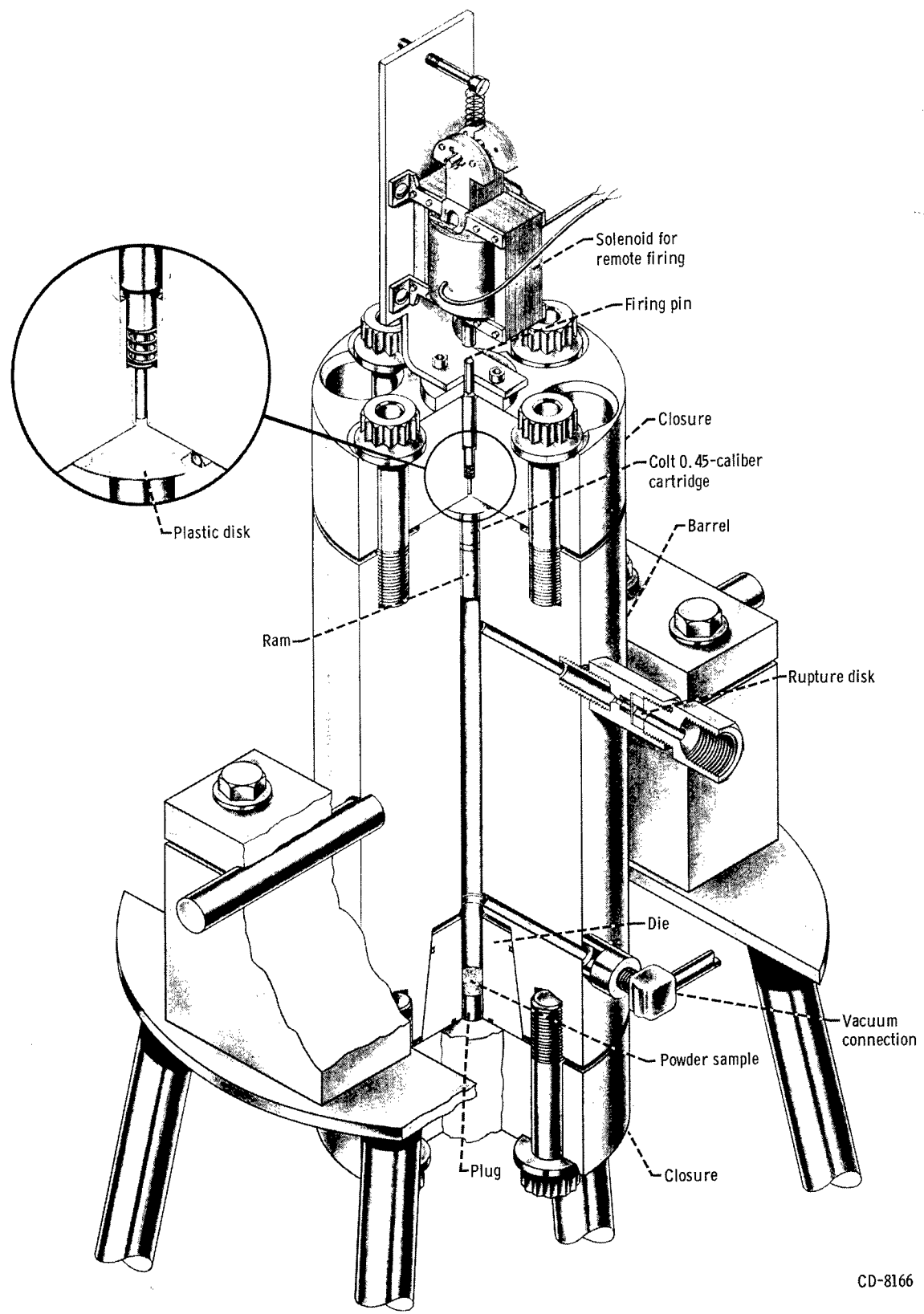
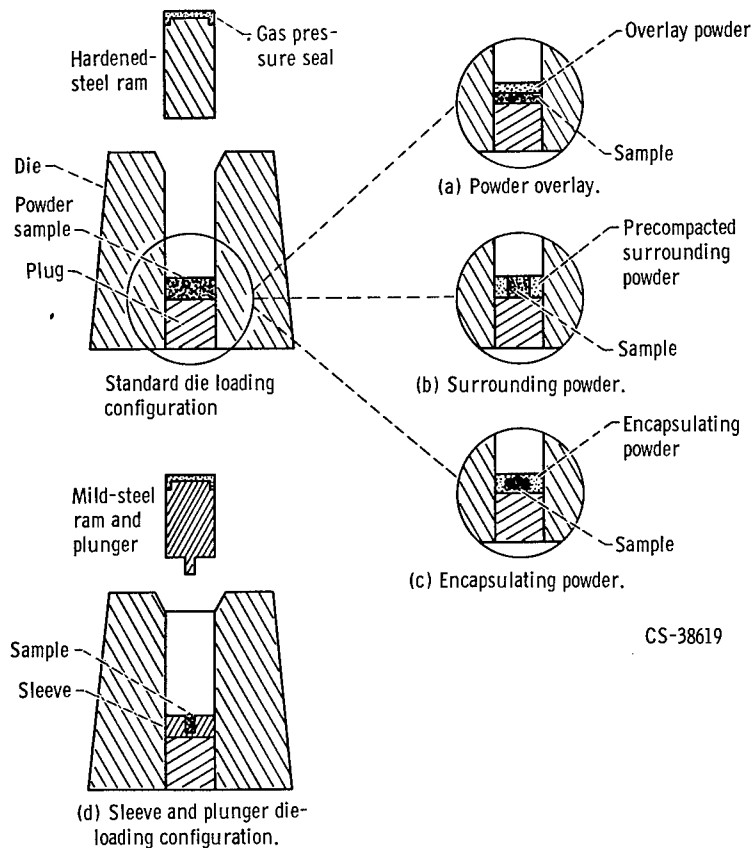

Figure 3. - Cartridge-actuated compaction press. Drawing not to scale.

CD-8166



CS-38619

Figure 4. - Special die-loading methods for use in cartridge-actuated compaction press.

pletely encapsulating the sample. Another method involving a sleeve and plunger device was also used. Figure 4 is a drawing of the cross section of the die, which illustrates the manner in which the die was loaded by using each of these techniques. The first method, an overlay method (fig. 4(a)), was successfully used with some nickel-base blends in the blended condition and was attempted with the tungsten-base material. For the overlay method, about 1 gram of sample and 1 gram of overlay powder were used. A second method, surrounding-powder method, was used to compact the tungsten-base blend (fig. 4(b)). This configuration was most readily achieved by prepressing a porous disk of copper powder about 1/8 inch thick by using a low-pressing pressure of about 10 000 pounds per square inch and drilling a small hole through the disk. The disk was then placed in the die, and a small sample of the blend to be compacted was placed in the hole. A third method, an encapsulating-powder method (fig. 4(c)), was used for compacting sintered specimens of irregular shape. The amount used was just sufficient to encapsulate the specimen completely. Finally, a fourth method, a sleeve-and-plunger method (fig. 4(d)), was also used for tungsten-base composite powders. The inside diameter of the sleeve was 0.125 inch. In this method and the surrounding-powder method the sample weight was about 0.3 gram. In each of these methods, the specimen

was removed from the die intact with either the encapsulation or overlay and mounted for polishing. The encapsulation was then ground off to reveal the desired section of the specimen.

Density measurements were made on integral compacted specimens by weighing them and by measuring the dimensions with a micrometer. If the pellet were cracked or had an irregular surface, the density was measured by a mercury immersion technique. The accuracy of the micrometer method was about  $\pm 0.1$  gram per cubic centimeter, and for the mercury method it was about  $\pm 0.001$  gram per cubic centimeter. Densities were reported as percent of theoretical density and were rounded to the nearest 1 percent. On pellets made with the overlay or encapsulating-powder methods, the theoretical density of the composite pellet was generally calculated from the weights of the sample and the added powder with the assumption that the added powder compacted to 95 percent of its theoretical density. With the other special methods, the densities were estimated by examining the microstructures.

## Postannealing

Annealing of compacted specimens was conducted in a resistance-heated vacuum furnace having a tungsten element wound on a cylindrical alumina refractory tube having a 3-inch inside diameter and 7-inch length. A tungsten crucible was used to hold the specimens. The furnace was evacuated to  $10^{-4}$  millimeter of mercury or better and heated to approximately  $600^{\circ}$  F. Hydrogen (purified through an activated alumina dryer and liquid nitrogen trap) was then admitted, and the temperature was slowly raised to the desired level ( $1600^{\circ}$  to  $1700^{\circ}$  F). The heatup time was nominally 4 hours, and the holding time was varied from 1 to 4 hours.

## Ram Velocity Determination

In order to determine the ram velocity obtainable for various charges, a series of measurements were carried out. The CACP was placed in a horizontal position with the die and closure removed. The end of the barrel was sealed with electrical tape and was evacuated. When fired, the ram ruptured the tape, traveled out into the air through two foil switches a distance of 1 foot apart, and stopped in a wooden block. The switches actuated an electronic interval timer, which measured the flight time for the 1-foot distance; this time was then used to determine velocity. The velocity measuring apparatus is described in reference 11.

Figure 5 shows the velocity calibration curve. Note that the charges most frequently

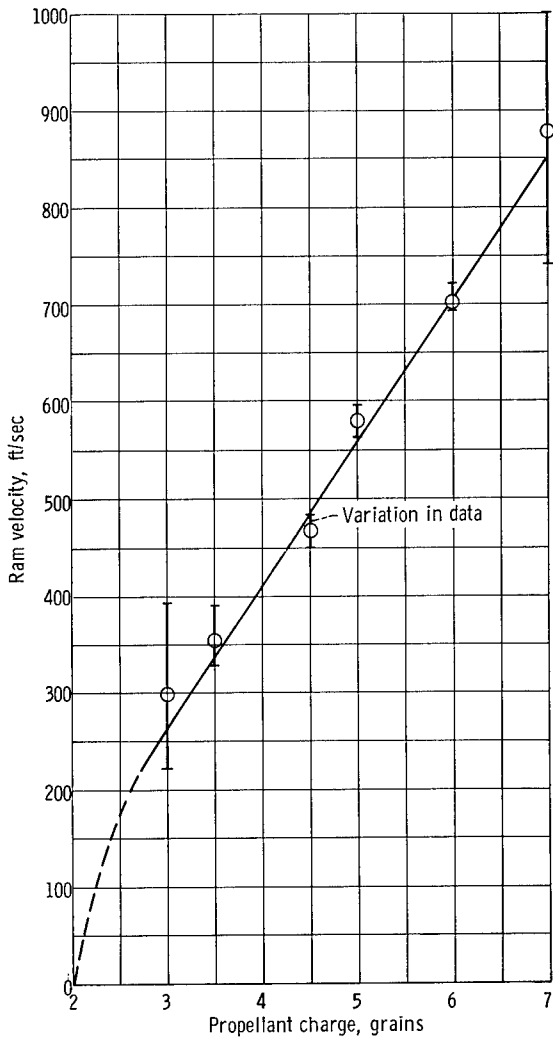

Figure 5. - Ram velocity as function of propellant charge.  
Ram weight, 22.5 grams; propellant, Bulseye powder.

used for compaction, 4.5 and 5 grains, correspond to velocities of 450 to 600 feet per second. The energy available for compaction at these velocities is 160 to 280 foot-pounds.

### Compaction with Dynapak Press

The principle of the Dynapak high-energy-rate extrusion press has been described by Rippel (ref. 12). The Lewis Research Center unit is a horizontal press (model 1800) having an 18-inch-diameter piston. The ram weight on this machine is 9000 pounds, and the support assembly weight is 16 000 pounds. Powders to be compacted were loaded into an aluminum die having 3-inch outside diameter and 0.810 inside diameter and fitted with a tool-steel plunger. The die-plunger assembly in position in the Dynapak Press is illustrated in figure 6. The sample was loaded into the die in an inert atmosphere dry box, and the plunger was pressed into the die with an internal pressure of 12 000 pounds per square inch by using a small laboratory press. This pressing operation was also carried out in a dry box, but the subsequent

compaction operations in the Dynapak were accomplished without protective atmosphere. Since no seal was provided on the die-plunger assembly, there was a possibility of air contamination. The entire assembly was loaded in the container of the extrusion press, and the fire pressure was adjusted to give relative ram-container velocities up to about 65 feet per second. Travel stops on the ram (see fig. 6) were adjusted so that the ram was stopped in a position that was calculated to achieve theoretical density in the compact. Compacted samples were removed by cutting the die open.

### Compaction with Sheet Explosive

The explosive compaction test was a single-trial test, which used a direct-contact

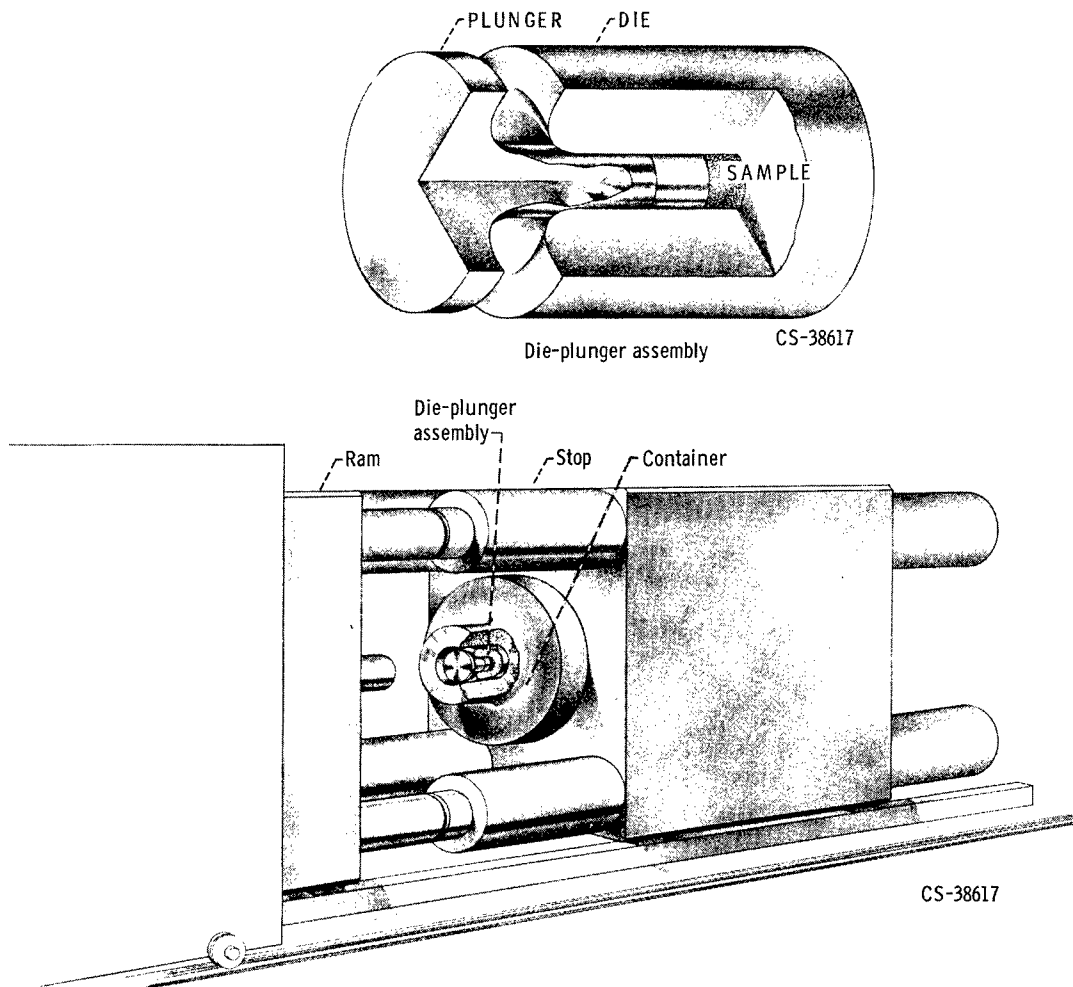

Figure 6. - High-velocity impact compaction in Dynapak.

sheet explosive. The tungsten-thoria blend for this test had been dry blended and hydrostatically cold pressed with a pressure of 30 000 pounds per square inch to an estimated 42 percent of theoretical density. After pressing, the billet was loaded into a 16 gage mild-steel can 2 inches in diameter by 4 inches in length. The can was vacuum sealed with an electron-beam welder. Preparation and canning of the billet was done at the Lewis Research Center, but explosive compaction was carried out as a service by Battelle Memorial Institute. A uniform wrapping of sheet explosive at a charge density of 7 grams of Dupont PETN per square inch of can surface was applied. The explosive-wrapped can was placed in a heavy-wall steel enclosure, and the whole assembly was lowered into a water tank for detonation. The Battelle facility, including water tank design, is described by Rinehart and Pearson (ref. 13).

TABLE II. - RESULTS OF COMPACTION STUDY

(a) Compaction with cartridge-actuated compaction press

Blend	Composition	Condition	Compaction		Pellet integrity	Percent of theoretical density	Post-compaction annealing treatment	Located in figure -		
			Powder charge, grains	Method <sup>a</sup>						
1	Nickel-alumina	Dry blended	4	Standard	Shattered	-----	-----	-----		
1			5	Standard	Cracked	-----	-----	-----		
1			7	Standard	Shattered	-----	-----	-----		
1			5	Overlay	Sound	-----	<sup>b</sup> 91	-----		
1			5	Overlay	Sound	-----	<sup>b</sup> 89	1 hr at 1700° F		
1			4.5	Standard	Sound	-----	89	-----		
2			Nickel-thoria	Liquid blended	4	↓	No compaction	-----	-----	-----
2					5		No compaction	-----	-----	-----
2					7		No compaction	-----	-----	-----
2					5		Shattered	-----	-----	-----
2	4.5	Shattered			-----		-----	-----		
2	5	Overlay			Pitted surface		-----	<sup>b</sup> 85	1 hr at 1700° F	
2	5	Standard			Sound		-----	93	-----	
2	5	Standard			Sound		-----	93	4 hr at 1700° F	
3	4.5	Standard			Sound		-----	91	-----	
3	4.5	Standard			Sound		-----	96	4 hr at 1700° F	
4	Nickel-alumina	Sintered at 1900° F	5	Encapsulating powder	Shattered	-----	-----	-----		
4	Nickel-alumina	Sintered at 1900° F	5		Cracked	<sup>b</sup> 89	-----	12(a), (b)		
7	Nickel-thoria	As received	4.5	Standard	Sound	96	1 hr at 1600° F	13(a)		
8	Tungsten-thoria	Hydrogen cleaned at 1600° F	5	↓	No compaction	-----	-----	-----		
8			6		-----	-----	-----			
8			7		-----	-----	-----			
8			5		Overlay	-----	-----			
8			6		Overlay	-----	-----			
8			7		Overlay	-----	-----			
8			5		Surrounding powder	-----	-----			
8			6		Surrounding powder	-----	-----			
8			7		Surrounding powder	-----	-----			
8			7		Surrounding powder	-----	-----			
8	5	Sleeve-plunger	Sound	-----	<sup>c</sup> 85 to 90	1 hr at 1700° F	13(b)			
9	Nickel-molybdenum-thoria	As received	5	Standard	Rough surface	<sup>b</sup> 86	-----	13(c)		

(b) Compaction with Dynapack

Blend	Composition	Condition	Estimated velocity, ft/sec	Result
5	Nickel-alumina	Cleaned at 850° F	210	Pellet delaminated; fragment estimated to be 85 percent of theoretical density (see fig. 14)

(c) Compaction with sheet explosive

Blend	Composition	Condition	Compaction	Result
6	Tungsten-thoria	Cleaned, precompact and canned in 2-in. -diam by 4-in. -long 16-gage mild steel	Wrapped in Dupont PETN explosive with charge of 7 g/in. <sup>2</sup>	Can ruptured during compaction; pieces retained had 90 percent of theoretical density (see fig. 15)

<sup>a</sup>Details of compaction methods are shown in figure 4.

<sup>b</sup>Theoretical densities were approximated on pellets made with overlay and encapsulating-powder methods.

<sup>c</sup>Density was estimated by inspection of structure with surrounding-powder method.

## Metallography

Successfully compacted specimens were mounted in Bakelite and prepared for electron microscopy. Standard metallographic polishing techniques were used for rough polishing, and final polishing was accomplished with 3-micron and 1/2-micron diamond compounds. A low-temperature etching technique was used for the nickel-base specimens. Specimens were immersed in liquid nitrogen and then quickly swabbed with an etching solution consisting of 92 percent hydrochloric, 3 percent nitric, 5 percent sulfuric acids diluted in water at a ratio of 4 parts acid to 1 part water. The low-temperature method was used to slow the etching rate. Slowing the etching rate enabled a fine control of the degree of etching, which had to be very light. Specimen staining was also reduced by the low-temperature etch. Tungsten-base specimens were etched by swabbing with an aqueous solution containing 10 percent lactic, 10 percent nitric, and 5 percent hydrofluoric acids. The specimens were then cleaned by depositing and stripping Parlodion-backed Mowital film and then repeating the procedure three times to remove all etching and polishing debris. A final Mowital replica was made and shadowed with either uranium dioxide or platinum, and a thin amorphous carbon film was applied. The Mowital was then dissolved, and the carbon film was transferred to the microscope grid.

## RESULTS

### Cartridge-Actuated Compaction Press

The results of the various compaction tests are given in table II and in figures 7 to 13. The initial tests to compact the nickel plus 5 percent aluminum oxide blend (blend 1) following the dry-blending operation and using the standard compaction method yielded poor results. The specimens were cracked and delaminated; however, relatively good specimens were obtained having a density of about 91 percent by using a nickel powder overlay. Figure 7 shows electron micrographs of blend 1 in both the compacted and annealed conditions. The structure in the compacted condition is difficult to interpret (fig. 7(a)) since a very rough matrix metal surface is noted; however, a study of the photomicrographs suggested that points such as those identified by the leaders are fine particles. A particle believed to be a large oxide particle is also identified. In the annealed condition (fig. 7(b)) the surface is smoother, and numerous particles as fine as 0.02 micron in diameter are clearly revealed at a magnification of 29 000. Grain boundaries and spherical pores are believed to develop during the annealing treatment. These pores are noted primarily around large oxide particles lying on grain boundaries and also at isolated points in the matrix. After the fine particles in figure 7(b) have been



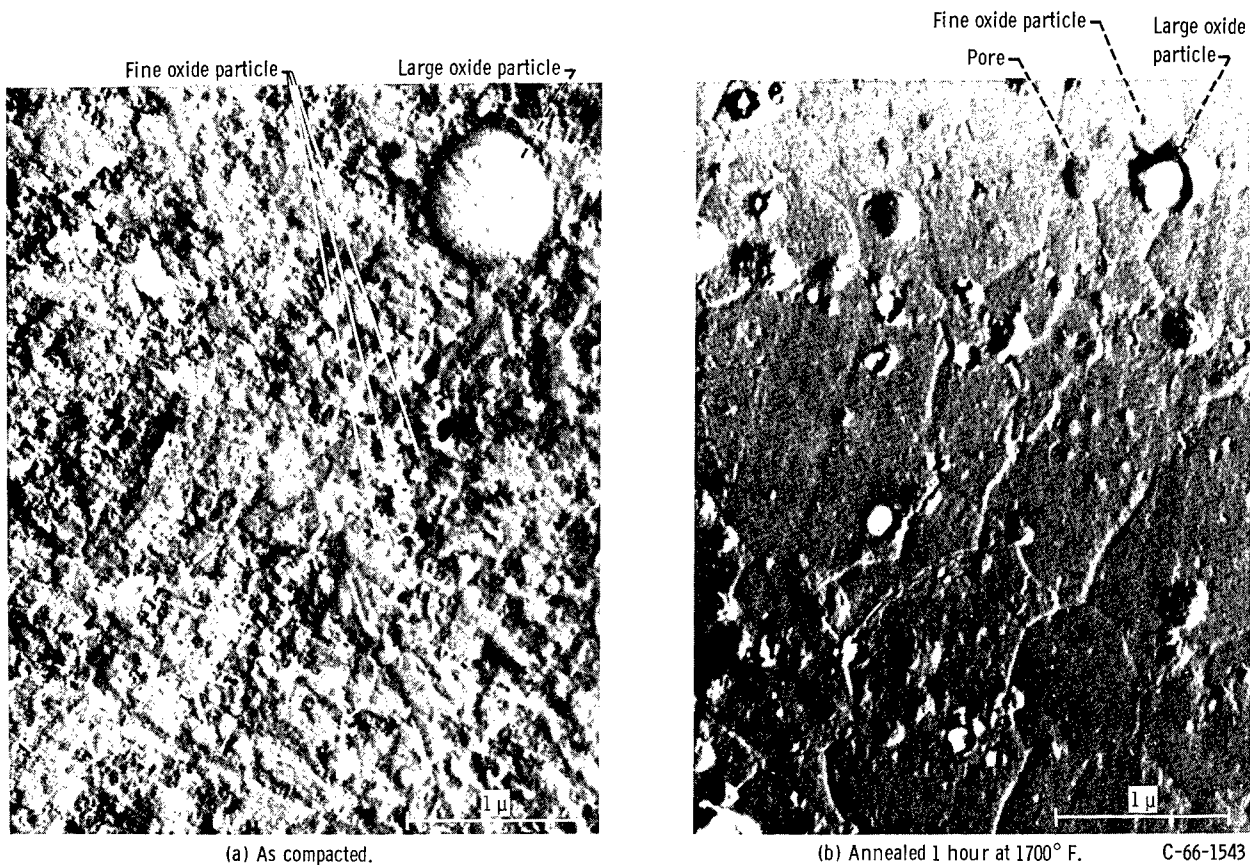

Figure 7. - Blend 1 (nickel - 5 volume percent alumina) dry blended in roll mill and compacted in cartridge - actuated compaction press using overlay method. Original magnification, X29 250.

studied, reference can be made to figure 7(a) to establish reasonably that the suspected fine particles are real because of their geometrical and shadowing characteristics. Carrying out quantitative metallography on the as-compacted structure would be almost impossible in this case because of the rough surface.

After the material of blend 1 (nickel - 5 percent alumina) was hydrogen cleaned, compaction was readily accomplished by using the standard technique without an overlay. The structure of this specimen is shown in figure 8. Numerous particles in the 0.01- to 0.1-micron range are visible in the structure even though the surface is slightly rough. Grain boundaries were not revealed in the unannealed condition.

Preliminary compaction tests made on liquid-blended mixture of nickel - 7.5 percent thoria (blend 2) were unsuccessful in the blended and dried condition; however, after using the vacuum heat treatment described previously to remove all traces of the surfactant, the tests shown in table II were carried out. A reasonably well-compacted specimen (85 percent of theoretical density) was obtained with the overlay method. The structure of this specimen after hydrogen annealing is shown in figure 9. Note that the same general features, as shown in figure 7(b), are present; however, the pores appear



Figure 8. - Blend 1 (nickel - 5 volume percent alumina) hydrogen cleaned at 950° F and compacted in cartridge-actuated compaction press using standard method. Original magnification, X29 250.

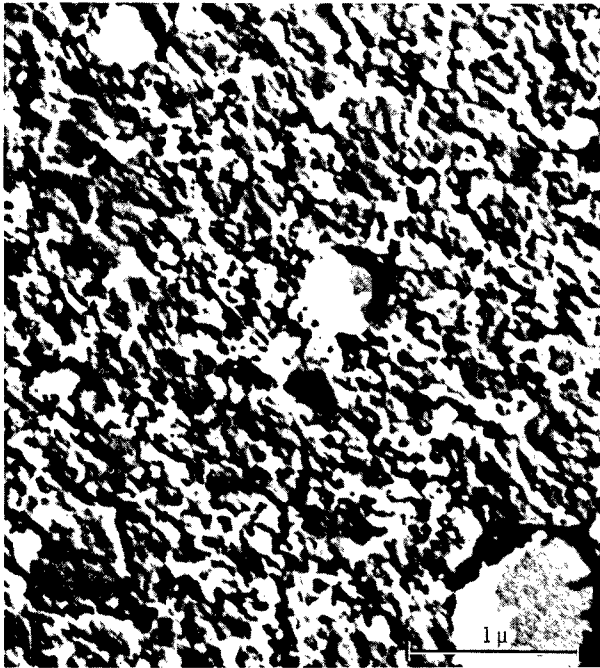

Figure 9. - Blend 2 (nickel - 7.5 volume percent thoria) liquid blended, vacuum dried at 950° F, compacted with cartridge-actuated compaction press using overlay method, and then annealed 1 hour at 1700° F. Original magnification, X29 250.

to be larger and angular rather than spherical. Although a few particles of about 0.02 micron in size have been preserved in the structure, the majority of the particles appear to be about 0.2 micron.

Hydrogen cleaning at 950° F also improved the ease with which the material of blend 2 could be compacted. As shown in the table, the standard technique resulted in 93 percent of theoretical density, whereas the uncleaned material required the overlay technique and a density of only 85 percent of theoretical density was obtained. Figure 10 shows the electron micrographs of this material in both the compacted and annealed conditions. In the compacted condition, the surface was very rough (fig. 10(a)); however, after annealing the surface was much smoother and particles in the range 0.02 to 0.2 micron were clearly revealed (fig. 10(b)). Blend 3 was of similar composition (nickel - 6.1 percent thoria) and was liquid blended as was blend 2 but was hydrogen cleaned at 1200° F rather than at 950° F. It was also readily compacted to a relatively high density (table II). The structure of the sample cleaned at the higher temperature was much more readily observed in the as-compacted condition and somewhat finer particles were observed in the annealed condition (compare figs. 10 and 11).

An attempt to compact the sintered blend of nickel - 9.4 percent alumina (blend 4) by



(a) As compacted.



(b) Annealed 4 hours at 1700° F.

C-66-1546

Figure 10. - Blend 2 (nickel - 7.5 volume percent thoria) hydrogen cleaned at 950° F and compacted with cartridge-actuated compaction press using standard method. Original magnification, X29 250.



(a) As compacted.

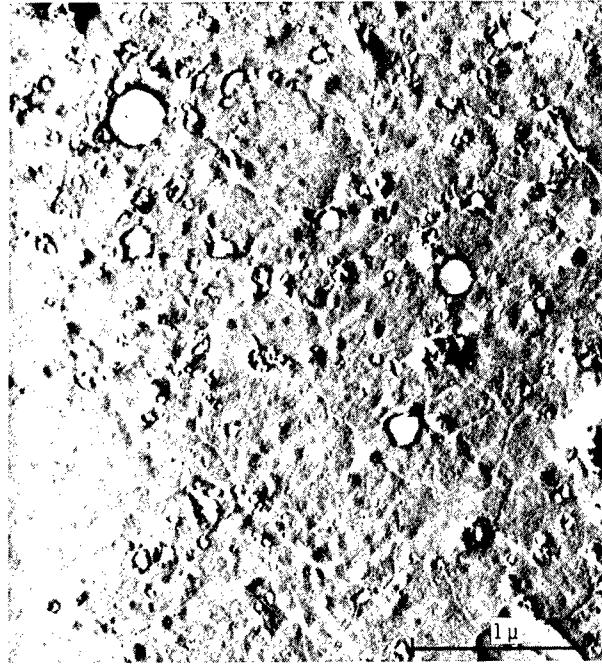

(b) Annealed 4 hours at 1700° F.

C-66-1547

Figure 11. - Blend 3 (nickel - 6.1 volume percent thoria) hydrogen cleaned at 1200° F and compacted with cartridge-actuated compaction press using standard method. Original magnification, X29 250.

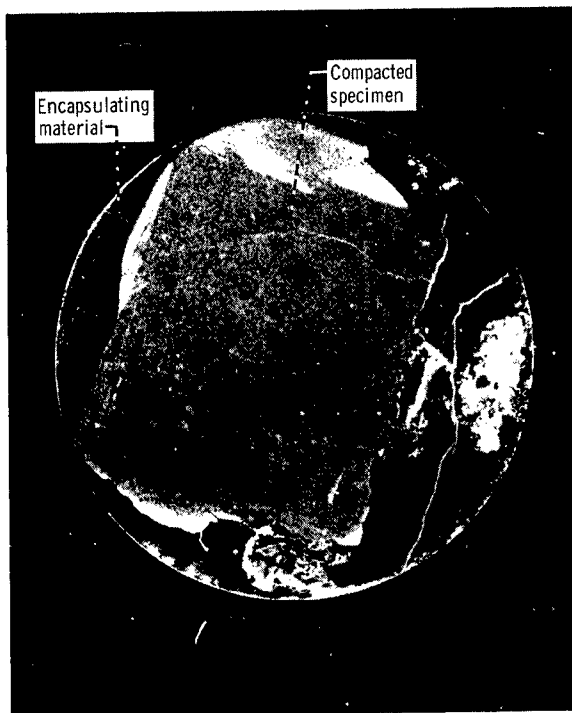

C-66-1548

Original magnification: X6

X9500

Figure 12. - Blend 4 (nickel - 9.4 volume percent alumina) sintered and compacted with cartridge-actuated compaction press using encapsulation technique.

using the standard technique caused the specimen to crumble into flakes; however, an integral specimen (fig. 12) was obtained with the encapsulating method. The macrograph (fig. 12(a)) shows the manner in which the specimen was surrounded with nickel powder. Although a crack was observed in the specimen, areas of the specimen were very dense, as shown in the electron micrograph in figure 12(b). In this view the surface appears relatively smooth, and particles are visible ranging in size from about 0.03 to about 0.2 micron. Note the stringering of the particles, as indicated by the leaders, that probably occurred during the blending and sintering of this blend, which contained a high volume of oxide.

The composite powder blend of nickel - 2 volume percent thoria (blend 7) made by the flash-drying technique was readily compacted to a density of 96 percent of theoretical density. The CACP did not have to be loaded and operated in a protective atmosphere dry box with this powder since the material was relatively coarse. The micrograph of this material (fig. 13(a)) clearly reveals particles as fine as about 0.01 micron in size although the surface is somewhat rough. Note that an annealing treatment of 1 hour at 1600° F was used on this material in contrast to the treatment of 1 or 4 hours at 1700° F as was used on the other specimens.

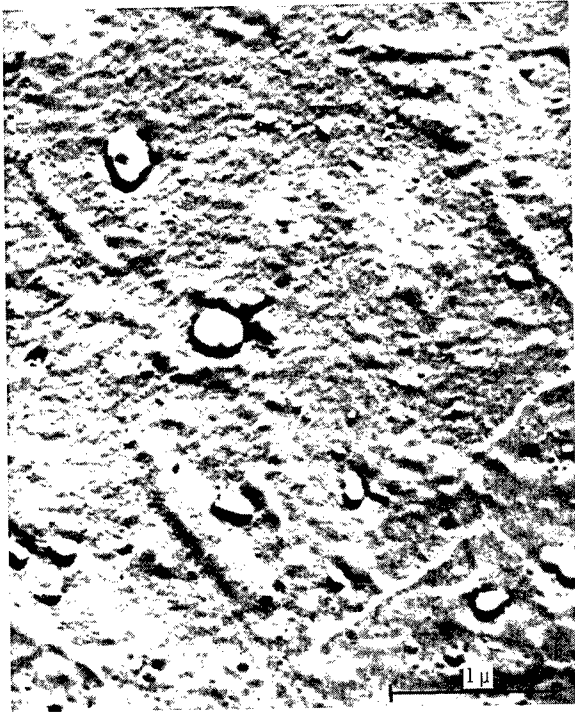

(a) Blend 7 (nickel - 2 volume percent thoria) produced by solution - flash-drying technique and compacted with standard method. Original magnification, X29 250.

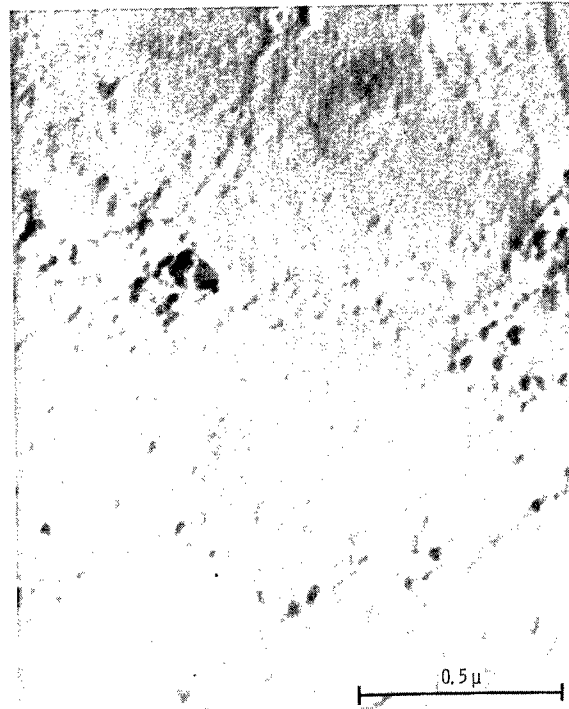

(b) Blend 8 (tungsten - 2 volume percent thoria) produced by arc-vaporization technique and compacted with sleeve-and-plunger method. Original magnification, X74 000.

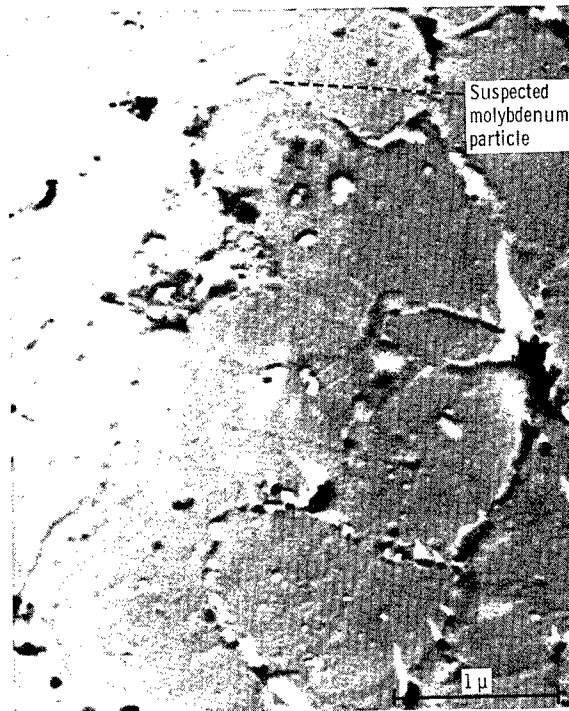

C-66-1549

(c) Blend 9 (nickel - 15 weight percent molybdenum - 4 volume percent thoria) produced by solution - spray-dry technique. Original magnification, X29 250.

Figure 13. - Dispersion alloy blends produced from composite powders compacted with cartridge-actuated compaction press.



C-66-1550

Figure 14. - Blend 5 (nickel - 6.5 volume percent alumina) hydrogen cleaned at 850° F and compacted with Dynapak. Original magnification, X19 000.

Considerable difficulty was encountered in attempting to compact the composite powder blend of tungsten - 2 volume percent thoria (blend 8) produced by the arc-vaporization method. The material did not compact at all with the standard or overlay methods using a powder charge of up to 7 grains. Some degree of compaction resulted with the encapsulation method, and a small fragment of the material was retained that had sufficient strength for mounting; however, a better result was obtained with the sleeve and plunger method. The density was estimated to be about 85 to 90 percent of theoretical density, as shown in table II. The structure shown in figure 13(b) shows a dispersion of fine oxide particles of about 0.01 to 0.04 micron in size. A very thin platinum shadowing was employed with a very high magnification to reveal the extremely fine particles; therefore, the contrast is relatively low.

The nickel-molybdenum - thoria alloy produced by the solution-spray dry technique is shown in figure 13(c). The compaction was made with the standard technique, and the density of the specimen is relatively low, about 86 percent of theoretical density. In addition to thoria particles dispersed within the grains, some material is present in the grain boundaries, which is believed to be incompletely dissolved molybdenum.

## Dynapak

Figure 14 shows a micrograph of a nickel-alumina specimen (blend 5) made by the liquid-blending process and compacted in the Dynapak. The specimen used for this micrograph was only a small piece since solid compacts were not achieved. Delaminated sections could be broken from the compact, which had sufficient density (estimated to be 85 percent of theoretical density or greater) for replication.

The difficulty in achieving integral compacts was probably due to the fact that the powders were not adequately protected from the atmosphere after pressing in the die

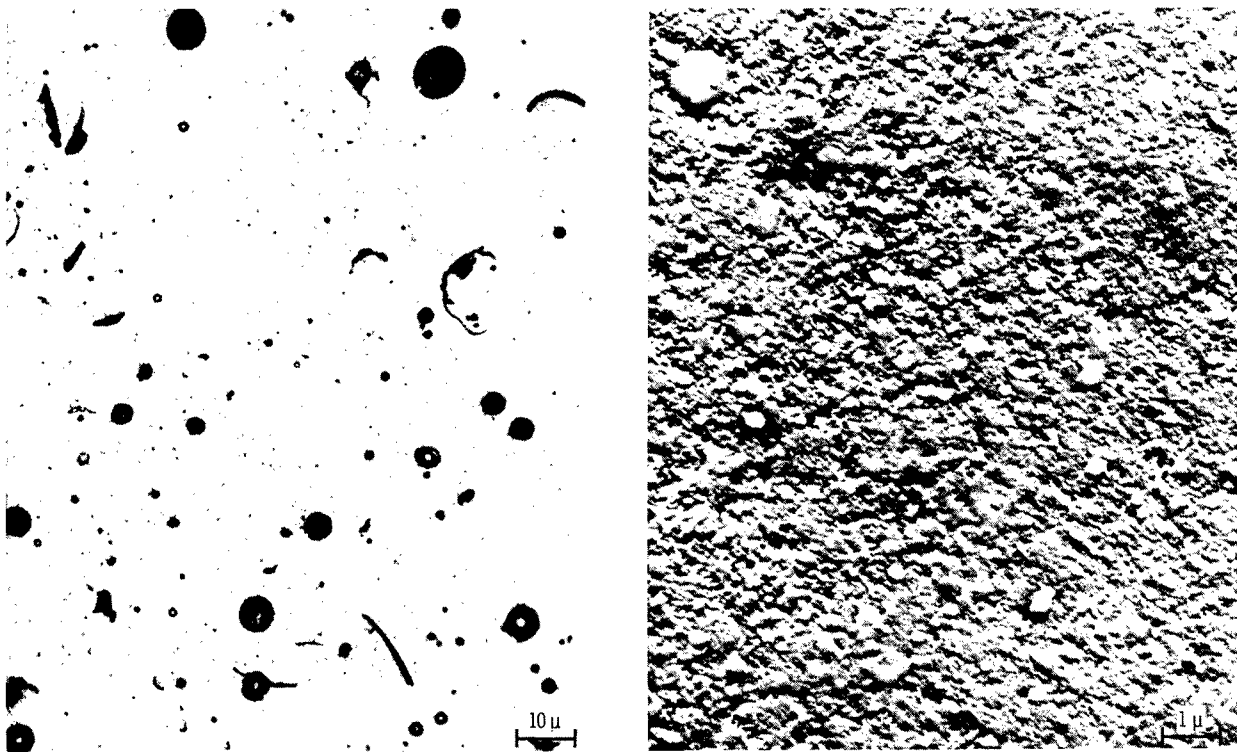

(a) Light micrograph. Original magnification, X1000.

(b) Electron micrograph. Original magnification, X12 000.

Figure 15. - Blend 6 (tungsten - 8 volume percent thoria) billet compacted with direct-contact sheet explosive.

since an adequate seal was not provided between the die wall and the plunger. Further tests and attempts to perfect the apparatus were not attempted as a part of this study.

### Direct-Contact Explosive Compaction

Explosive compaction of the tungsten-thoria billet with wrapped sheet explosive did not result in an integral billet because of cladding rupture but yielded a number of pieces suitable for study (see fig. 15). The light micrograph (fig. 15(a)) shows the presence of a large number of coarse particles of thoria; however, the electron micrograph (fig. 15(b)) also indicates a dispersion of particles in the 0.05 to 0.7 micron range.

### DISCUSSION OF RESULTS

The results of this investigation have demonstrated successful use of high-energy-rate compaction methods for consolidating powder blends of dispersion-strengthened materials to permit their examination by electron microscopy. Consolidation was

accomplished without the application of high temperatures and apparently without appreciable agglomeration of the dispersoid. Electron micrographs of some compacted specimens revealed particles ranging in size as fine as 0.01 micron, as shown, for example, in figures 8, and 10 to 13. The particles observed are thus in the size range considered desirable for dispersion strengthening. This particle size further suggests that the blending methods seem to be adequate.

## Cartridge-Actuated Compaction Press Studies

The CACP proved to be a convenient laboratory tool. Its small size permitted loading and firing within an inert-atmosphere dry box. Materials such as those made with submicron powders, which are sensitive to contamination by the air, may thus be readily provided with the necessary atmospheric protection. The 0.45-inch-diameter by 1/16-inch-thick specimen size is convenient for metallographic work and advantageous in conserving materials that may be very expensive to produce.

Thermal treatments. - Although the initial objective of the investigation was to compact specimens without the application of any heat, better results were generally obtainable if low-temperature thermal treatments were used. These treatments consisted of a hydrogen-cleaning treatment for powder blends before compaction or an annealing treatment on the compacted specimens. The temperatures used in the hydrogen cleaning of nickel-base blends were 950<sup>o</sup> to 1200<sup>o</sup> F, and annealing was done at 1600<sup>o</sup> or 1700<sup>o</sup> F. Figure 8 reveals particles ranging in size from 0.01 to 0.1 micron, and measurements from several micrographs of this material (blend 1) gave an average particle size of 0.03 micron. This value is relatively close to the measured particle size of the starting alumina powder (0.023  $\mu$ ), and any agglomeration due to the cleaning treatment was, therefore, relatively slight. Comparison of figures 10(a) and (b) suggested that the annealing treatment did not significantly agglomerate the structure. The measured average particle size of the dispersoids in blend 3 (whose average starting particle size was 0.029  $\mu$ ) after cleaning (fig. 11(b)) was 0.04 micron, which size again suggests only slight agglomeration. On the other hand, temperatures of 2000<sup>o</sup> F or higher which are necessary to sinter or hot press according to conventional compaction procedures were found to result in severe agglomeration and particle coarsening (see appendix).

In addition to improving the appearance of the structures, hydrogen cleaning also improved the compactability. For example, the dry-blended material (blend 1) could not be compacted in the blended condition without resorting to the overlay technique, but it was readily compacted with the standard technique after cleaning. Liquid-blended materials could not be compacted without exposure to elevated temperatures to remove the



residual adsorbed oleic acid. Vacuum heat treatment at 950<sup>o</sup> F somewhat improved compactability, but much better compactability resulted when hydrogen cleaning was used (see table II). The effect of hydrogen cleaning in improving compactability and yielding improved microstructures is probably a result of two factors: removal of matrix metal oxide and increasing metal particle size. The as-received metal powders used to make these specimens were extremely fine and contained oxides, which may be present largely as surface films. Also the high surface area of the particles makes them reactive and susceptible to further oxidation when exposed to air. Hydrogen cleaning at these temperatures reduces the oxide content and yields cleaner particle surfaces that deform and bond more readily. Sintering in its initial stages also occurs in the powder bed during cleaning and causes a pronounced increase in bulk density. Both of these factors would tend to improve compaction.

Annealing compacted specimens has been shown to improve the clarity of the microstructures. The matrix surface was smoother, and the particles were more clearly revealed after annealing. Rough surfaces observed in the compacts prior to annealing are probably due to the highly worked condition of the metal. Also, microporosity is present in some of the as-compacted specimens, as shown, for example, in figure 11. The effect of the annealing treatment is apparently to stress relieve the matrix and also to close up microporosity by incipient sintering. On the specimens studied, a combination of hydrogen cleaning before and annealing after compaction was observed to give the best resolution of the dispersoid particles. If prior hydrogen cleaning was omitted, the compacted-specimen density sometimes decreased upon annealing. Cracks or large pores appeared, probably as a result of gases entrapped within the highly densified compacts. Large pore formation is illustrated in figure 7(b) where prior hydrogen cleaning was not used.

Special die configuration. - The special techniques illustrated in figure 6 were developed for use on materials that could not be compacted with the standard method of impacting the specimen directly with the ram. As mentioned previously, the uncleaned blended powders had a tendency to delaminate with the standard technique. Apparently the cause of failure was that the compacts did not have sufficient strength after the compressive impulse of the projectile to withstand the tensile forces generated by reflected shock waves. It was reasoned that an overlay powder that was known to have good compacting characteristics would form a bond to the sample. The compacted overlay would then tend to absorb some of the energy of the reflected wave and hold the specimen together during ejection from the die. In practice the method was found to be satisfactory on the uncleaned nickel-base blends but it was of no help in attempts to compact tungsten-base materials.

The encapsulation technique also shown in figure 4 was developed to aid in the compaction of sintered specimens. These specimens tended to shatter even though they had

appreciable strength prior to compaction. The sintered specimens were cut from the billet with a hacksaw and were not accurately fit to the die. Tensile forces were reasoned to generate as the specimen was deformed to the shape of the die cavity, and fracture took place along the planes of these forces. The encapsulating powder was envisioned as acting in a manner analogous to a fluid (i. e., transmitting uniform compressive forces about the specimen). The encapsulating powder would also help to hold the specimen together and to absorb the reflected tensile shock wave as did the overlay powder.

In the initial attempts to compact tungsten-thoria samples no successful compactations were achieved with either the standard or overlay methods. The high modulus of elasticity, high yield strength, and high ductile-brittle transition temperature of tungsten are probably the factors that caused the difficulty in compaction. A similar difficulty in compacting tungsten has also been reported by Hagenmeyer (ref. 14). Although he had experimented with impact velocities up to 1600 feet per second, no compaction was achieved; therefore, further trials to use higher charges and overlays were abandoned, and the surrounding-powder method was attempted. It was reasoned that by reducing the diameter of the tungsten specimen to a small size in the center of a soft die insert, an increase in the compacting force on the tungsten specimen could be achieved. Some success was attained with the surrounding-powder technique by precompacting a 1/8-inch-thick disk with a static pressure of 20 000 pounds per square inch, drilling a 1/8-inch-diameter hole in the center, and loading the sample in the hole. A usable specimen resulted, which was polished and replicated, but the final micrograph was of poor quality. This concept led to the construction of the sleeve-and-plunger apparatus. The configuration gave a decrease in sample area of a factor of 16, with a corresponding increase in pressure. This latter method gave better compaction and was less time consuming than the surrounding-powder method. The micrograph obtained on tungsten-base material (fig. 13(b)) suggested that the material was relatively dense. It should be noted that the specimen size was limited with this method.

## Dynapak

The test conducted with the Dynapak, although limited in scope, indicates that compacts that are suitable for electron microscopy can be obtained with the apparatus. The compact obtained, however, had a tendency to delaminate, and the density was not as high as for the compact obtained with the CACP (table II). The tendency to delaminate and the lower density were probably due to the fact that the protection from atmosphere was not adequate. The initial static pressing of the specimens was done in argon, but the die loaded with the compressed powder was then transferred in air to the Dynapak

for compaction. No method was employed to remove entrained gas other than the static prepressing of the specimen. Thus, it is not surprising that compaction was not as effective as it was with the CACP, which was evacuated immediately prior to pressing.

Note that the velocity of the projectile at impact in the experiment with the Dynapak was 210 feet per second. This velocity is less than one-half the projectile velocity that was found to be effective in compacting specimens in the CACP. Total calculated energy available in the Dynapak in this experiment was about 70 000 foot-pounds, or 2 500 foot-pounds per gram of sample, whereas the total available energy with the CACP is only about 220 foot-pounds, or 120 foot-pounds per gram of sample with a normal charge. Apparently only a small fraction of the Dynapak energy goes into actual compaction of the specimen, with deformation of the plunger and die absorbing a larger fraction. The remainder of the energy is then absorbed in the ram stops on the machine. The ram stops must be adjusted carefully to prevent damage to the die container. Operation of the CACP was considerably less difficult in practice since no such critical adjustments were required.

### Sheet-Explosive Compaction

Although the single attempt to compact the billet made with direct-contact sheet explosive did not yield a complete billet because the can ruptured during compaction, the potential of the method was indicated. Since explosive compactions of tungsten and tungsten containing a coarse oxide dispersion have been successfully demonstrated to obtain densities up to 97 percent of theoretical density (ref. 13, p. 328), the success of the operation for dispersion alloy blends seems probable. Further experimental work in this area to modify the can design should yield uniform compacts of high density.

In comparison with the CACP and Dynapak methods, the use of direct-contact sheet explosive offers the advantage of a much higher velocity shock wave (on the order of 20 000 ft/sec (ref. 13, p. 20)) which should produce considerably higher pressures and higher deformation rates. These factors may prove to be of considerable advantage for tungsten-base blends.

### Possibilities of Further Development

A modification of the CACP that appears beneficial would be the adaptation of a chamber within the barrel that would enable slight heating of the sample prior to impaction. This modification would permit more effective degassing of the powder specimens because they could be evacuated at elevated temperatures. Another advantage would be that a

study could be made of the effect of heating tungsten-base blends to temperatures above the ductile-brittle transition temperatures of tungsten. Further efforts to provide effective evacuation of a die for use in the Dynapak might also yield these benefits since the Dynapak is already equipped with the means for preheating billets.

Results of this study suggest that high-energy-rate compaction methods may find application in the fabrication of dispersion alloys on a billet-size scale. Since compaction to high densities may be achieved while retaining a distribution of the fine dispersoid, this method might be used in place of conventional pressing and sintering.

High-energy-rate methods might also be of benefit in making dispersion materials having alloy matrices from elemental powders. Diffusion alloying would be expected to be aided by the fineness of the matrix powder and the intimate contact between particles achieved by impacting to a high density.

As a laboratory tool the CACP may also prove useful as an aid in obtaining accurate chemical analyses for oxygen on fine metal powders. Fine powders have a tendency to oxidize in air, and it is difficult to get them into an analysis apparatus without some contamination. This difficulty can be circumvented by first compacting the powders in the CACP by using a protective-atmosphere dry box. If sufficient density is achieved, the compacts might readily be handled in air. The ability to compact materials to high densities might also be useful in preparing couples for diffusion studies involving powders or perhaps powders in combination with sheet or foil materials.

The tests conducted in this investigation involved three specific high-energy-rate methods. Presumably other types of apparatus capable of yielding high velocity impact might also be utilized for this purpose. Such simple equipment as a hammer forge or pneumatic jack hammer might prove effective in many instances.

## CONCLUSIONS

An investigation was undertaken to determine the feasibility of high-energy-rate compaction as a means of compacting metal plus oxide powder blends used in the preparation of dispersion-strengthened materials. Tests were conducted on nickel-base and tungsten-base blends by using three different compaction methods. The following conclusions were drawn from this investigation:

1. High-energy-rate compaction methods were successfully used to consolidate powder blends to sufficient density to enable examination with electron microscopy. Compaction was accomplished without the application of high temperature; thus agglomeration which might result through diffusion or chemical reaction was avoided. Further, etching and replication of the cold-consolidated specimens was capable of revealing

particle sizes as fine as 0.01 micron which is within the range considered desirable for dispersion strengthening.

2. The methods developed were applicable in evaluating blending and other processing operations used in the preparation of dispersion alloys.

3. The cartridge-actuated compaction press (CACP) proved to be a practical laboratory apparatus to compact nickel- and tungsten-base blends effectively. Of particular importance was the small sample size required for the CACP. This size permitted sampling from any point of the processing schedule without the need of large quantities of material.

4. Hydrogen cleaning of blends before compaction resulted in micrographs that showed improved particle contrast relative to material that was not cleaned.

5. Annealing compacted specimens in hydrogen resulted in smoother matrix surfaces, promoting an improved contrast of the dispersoid particles. An annealing temperature of 1700° F did not appear to cause any appreciable agglomeration of thoria or alumina in nickel.

6. In limited tests, the Dynapak and direct-contact sheet explosive methods were effective means of consolidating these materials.

Lewis Research Center,

National Aeronautics and Space Administration,

Cleveland, Ohio, March 29, 1966.

## APPENDIX - OTHER TECHNIQUES INVESTIGATED FOR EXAMINATION OF POWDER BLENDS

The following three techniques received preliminary investigation as possibilities for methods of examining fine powder blends: (1) conventional sintering or hot-pressing of blend samples, (2) dispersal of the blend in a plastic film, and (3) vacuum infiltration of the blended powder with a plastic and then cutting a thin slice with an ultramicrotome. None of these methods gave results that permitted accurate observation of the degree of blending attained. Methods 2 and 3, at least, offer the possibility of providing some qualitative information about the blends, which may serve to supplement observations made by high energy rate compaction methods.

### Sintering or Hot Pressing

The conventional approach of powder metallurgists, namely sintering or hot-pressing a blend sample to densify it sufficiently to permit normal metallographic polishing and examination, proved inadequate because the necessary application of heat

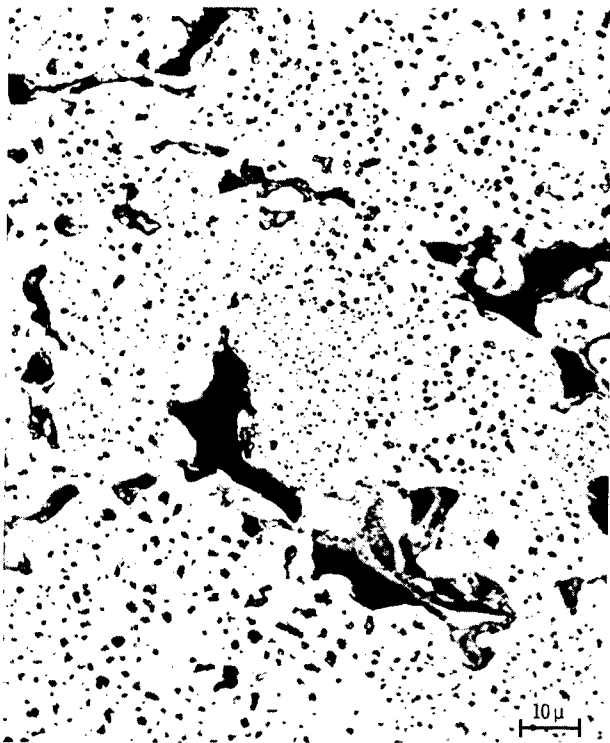
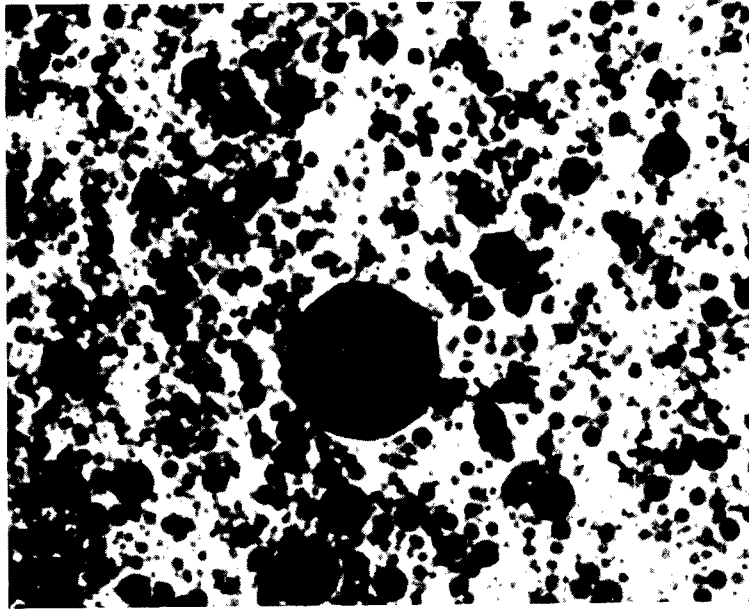
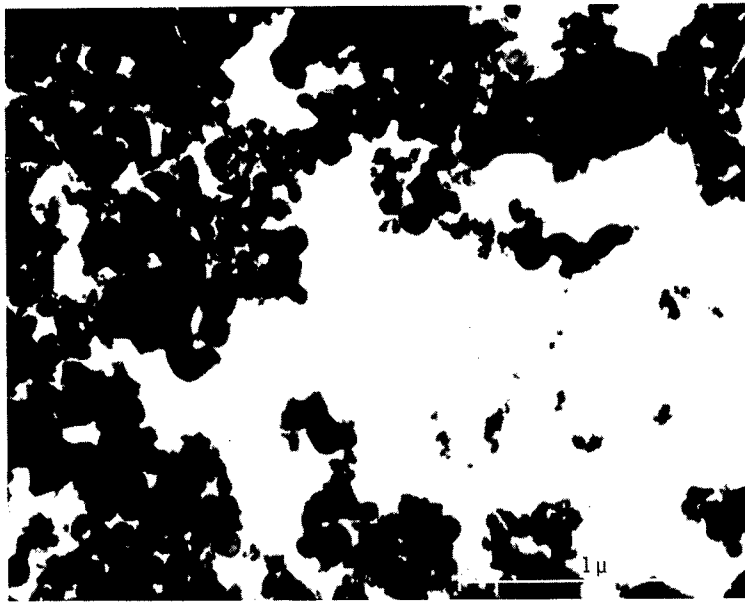

Figure 16. - Blend specimen of nickel - alumina pressed and sintered in hydrogen for 4 hours at 2000° F. Original magnification, X1000.

caused agglomeration of the dispersoid particles. From past experience, it was at first thought that agglomeration might be avoided if metal powders were precleaned in hydrogen to remove reducible matrix-metal oxides (such as NiO or WO<sub>3</sub>) before blending or before compacting the blended sample. Numerous tests showed, however, that even when the powders were carefully precleaned, severe agglomeration of the dispersoid particles still occurred during subsequent high-temperature sintering. Figure 16, which is a photomicrograph at X1000 of a nickel-alumina blend specimen sintered at 4 hours in hydrogen 2000° F, shows an example of such a result. The large, irregular areas are pores not yet closed by sintering, but the rounded particles already represent an advanced stage of agglomeration of the alumina. Hot pressing also produced severe agglom-



(a) Aluminum oxide.



(b) Nickel.

C-66-1553

Figure 17. - Electron micrographs of as-received submicron powders of alumina and nickel in plastic film. Original magnification, X46 000.

eration of the dispersoid.

## Dispersion in Plastic Film

The method of dispersing a powder in a quantity of Parlodion - amyl acetate solution and laying down a film on an electron-microscope support grid is a method normally used to examine the shape and size of single-phase submicron powders. An attempt was made to use this method for the examination of blends. As applied to blends, this method was found to have several serious disadvantages. A serious objection was that severe agitation was required to spread out particles so that they could be observed in shadowgraph fashion as a two-dimensional array. The severe agitation introduced an obvious uncertainty as to how well the two-dimensional result represents the original as-blended

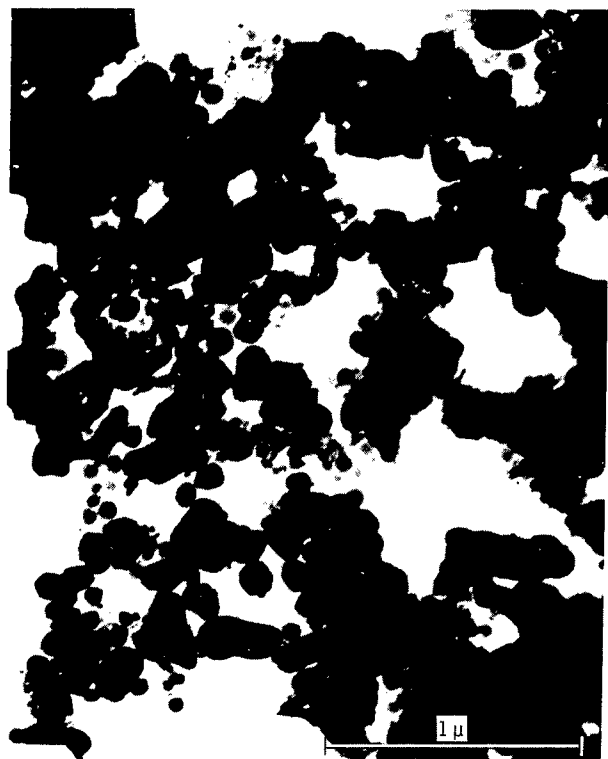

C-66-1554

Figure 18. - Electron micrograph of preblend specimen of nickel - 8 volume percent alumina dispersed in plastic film. Original magnification, X46 000.

condition. Typical results are presented in figures 17 to 20. Figure 17 shows original submicron nickel and alumina powders. Figure 18 shows a blend of these powders prepared in a Waring Blendor. In the blend micrograph, some alumina particles can be identified because of their characteristic spherical shapes, but particles in clusters cannot be identified. Moreover, some blends are made from powders that have similar particle shapes. Figure 19, for example, shows as-received tungsten and thoria powders. A blend of these powders is shown in figure 20. Positive identification of any particle in the electron micrograph of the blend is difficult. The main value of this method is to observe the particle size distribution and particle shapes and to obtain a qualitative indication of the state of aggregation of the particles. These characteristics can be important for efficiency of blending; for example, compare the two powders in figure 17 for difference in shape and state of agglomeration.

## Vacuum Infiltration of Powder Blends

In order to minimize the severe mechanical agitation associated with the dispersion



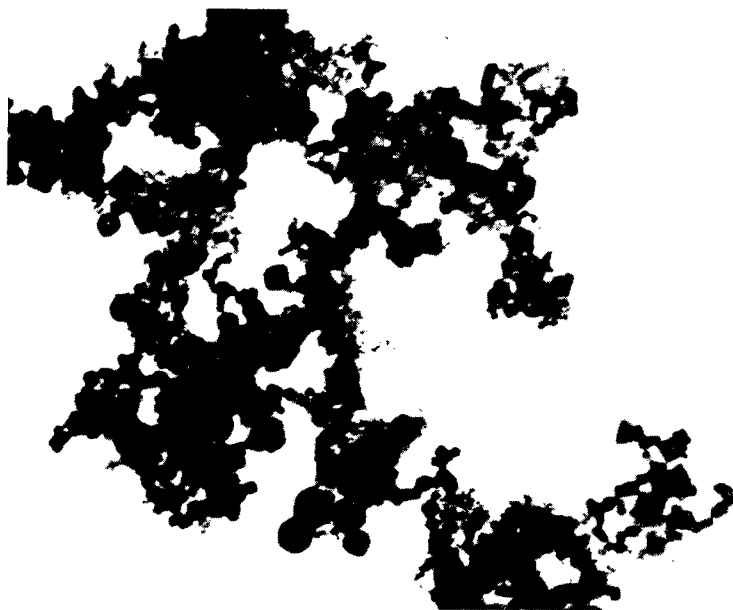

(a) Thoria.

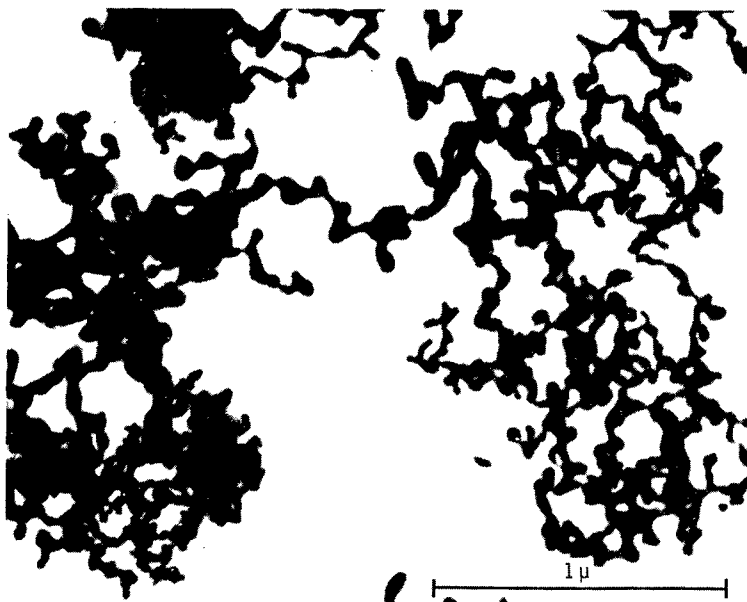

(b) Tungsten.

C-66-1555

Figure 19. - As-received submicron powders of thoria and tungsten dispersed in plastic film. Original magnification, X50 000.

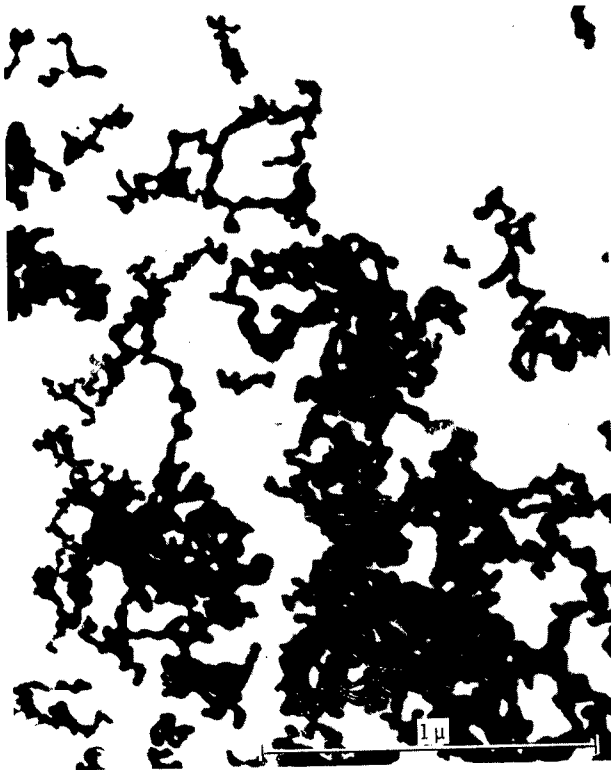

Figure 20. - Electron micrograph of blend specimen of tungsten - 5 volume percent thoria dispersed in plastic film. Original magnification, X58 000.

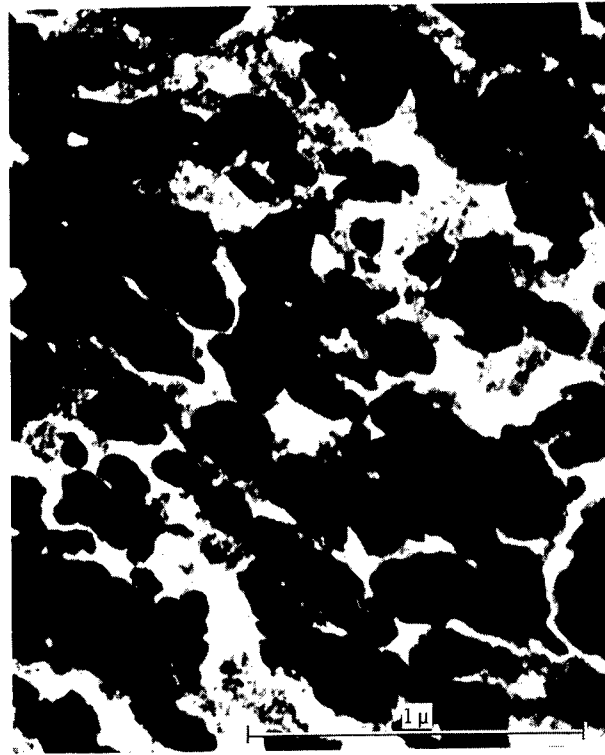

Figure 21. - Electron micrograph of nickel - 5 volume percent alumina wet blended in SMD colloid mill and hydrogen cleaned for 2 hours at 800° F. Blend specimen was vacuum infiltrated with resin and sliced in ultramicrotome. Original magnification, X58 000.

in plastic film method, a method of infiltrating a blend specimen with plastic was attempted. Loose or slightly tamped powder blends were poured into a cup and subjected to a vacuum to remove entrained gas. A low viscosity resin, Impco RC-2, was introduced under pressure from a connecting cylinder without disturbing the powder bed, at least on a macroscale. The impregnated block was then cured at 285° F. The hardened block was then sliced on a Fernandez-Moran ultramicrotome to obtain slices less than 0.1 micron thick. Figure 21 shows an electron micrograph of such a slice in which a blend of nickel and alumina powders had been hydrogen cleaned at 800° F before being sampled. The size of the large dark particles suggested that sintering of the major phase, nickel, had begun at 800° F. The very fine light gray phase may tentatively be considered to be alumina. (Note that a finer alumina powder was used in this blend than that used in the blend shown in fig. 17(a).) A question arises as to whether the fine phase may have been separated from the sintered nickel clusters by the action of the infiltrant. Although it is not possible to see whether alumina particles are also entrapped in any of the nickel clusters, it is possible to note that such a fine phase is still present.

## REFERENCES

1. Bruckart, W. L.; and Jaffee, R. I.: High-Temperature Properties of Molybdenum-Rich Alloy Compositions Made by Powder-Metallurgy Methods. Symposium on Metallic Materials for Service at Temperatures Above 1600<sup>o</sup> F. STP No. 174, ASTM, 1956, pp. 111-134.
2. Zwilsky, Klaus M.; and Grant, Nicholas J.: Copper-Silica and Copper-Alumina Alloys of High-Temperature Interest. Trans. AIME, vol. 209, Oct. 1957, pp. 1197-1201.
3. Schafer, Robert J.; Quatinetz, Max; and Weeton, John W.: Strength and High-Temperature Stability of Dispersion Strengthened Nickel-MgO Alloys. Trans. AIME, vol. 221, Dec. 1961, pp. 1099-1104.
4. Zwilsky, K. M.; and Grant, N. J.: Dispersion Strengthening in the Copper-Alumina System. Trans. AIME, vol. 221, Apr. 1961, pp. 371-377.
5. Worn, D. K.; and Marton, S. F.: Some Properties of Nickel Containing a Dispersed Phase of Thoria. Powder Metallurgy, W. Leszynski, ed., Interscience Pub., Inc., 1961, pp. 309-342.
6. Cremens, Walter S.; and Grant, Nicholas J.: Preparation and High-Temperature Properties of Nickel Al<sub>2</sub>O<sub>3</sub> Alloys. Proc. ASTM, Vol. 58, 1958, pp. 714-732.
7. Cremens, W. S.: Use of Submicron Metal and Nonmetal Powders for Dispersion-Strengthened Alloys. Ultrafine Particles, W. E. Kuhn, ed., John Wiley & Sons, Inc., 1963, pp. 457-478.
8. Nelson, R. C.; Zwilsky, K. M.; and Grant, N. J.: Evaluation of Ultrafine Metal Powders for Dispersion Hardening Purposes. New England Materials Lab., Inc., Aug. 31, 1961.
9. Triffleman, B.: A New Prealloyed Powder Process and Product. Vol. 18 of Progress in Powder Metallurgy, Metal Powder Assoc., 1962, pp. 156-165.
10. Stein, Eugene M.; Van Orsdel, John R.; and Schneider, Peter V.: High Velocity Compaction of Iron Powder. Metal Prog., vol. 85, no. 4, Apr. 1964, pp. 83-87.
11. Stepka, Francis S.; and Morse, C. Robert: Preliminary Investigation of Catastrophic Fracture of Liquid-Filled Tanks Impacted by High-Velocity Particles. NASA TN D-1537, 1963.
12. Rippel, J. M.: High Energy Rate Extrusion. Rept. No. ML-TDR-64-312, Westinghouse Electric Corp., Sept. 1964.

13. Rinehart, John S.; and Pearson, John: Explosive Working of Metals. The MacMillan Co., 1963, pp. 226-227.
14. Hagemeyer, J. W.: Dynamic Ultrahigh Pressure Research. Research Summary - Applied Research Program, July-December, 1963. Rept. No. ARR-5, General Dynamics/Fort Worth, Feb. 20, 1964, p. 120.

*"The aeronautical and space activities of the United States shall be conducted so as to contribute . . . to the expansion of human knowledge of phenomena in the atmosphere and space. The Administration shall provide for the widest practicable and appropriate dissemination of information concerning its activities and the results thereof."*

—NATIONAL AERONAUTICS AND SPACE ACT OF 1958

## NASA SCIENTIFIC AND TECHNICAL PUBLICATIONS

**TECHNICAL REPORTS:** Scientific and technical information considered important, complete, and a lasting contribution to existing knowledge.

**TECHNICAL NOTES:** Information less broad in scope but nevertheless of importance as a contribution to existing knowledge.

**TECHNICAL MEMORANDUMS:** Information receiving limited distribution because of preliminary data, security classification, or other reasons.

**CONTRACTOR REPORTS:** Technical information generated in connection with a NASA contract or grant and released under NASA auspices.

**TECHNICAL TRANSLATIONS:** Information published in a foreign language considered to merit NASA distribution in English.

**TECHNICAL REPRINTS:** Information derived from NASA activities and initially published in the form of journal articles.

**SPECIAL PUBLICATIONS:** Information derived from or of value to NASA activities but not necessarily reporting the results of individual NASA-programmed scientific efforts. Publications include conference proceedings, monographs, data compilations, handbooks, sourcebooks, and special bibliographies.

*Details on the availability of these publications may be obtained from:*

SCIENTIFIC AND TECHNICAL INFORMATION DIVISION  
NATIONAL AERONAUTICS AND SPACE ADMINISTRATION

Washington, D.C. 20546