

REPORT DOCUMENTATION PAGE

AFRL-SR-BL-TR-02-

Public reporting burden for this collection of information is estimated to average 1 hour per response, including the time for reviewing instructions, searching existing data sources, gathering the data, reviewing the collection of information, Send comments regarding this burden estimate or any other aspect of this collection of information, including suggestions for reducing the burden, to Washington Headquarters Service, Paperwork Project Office, 1215 Jefferson Davis Highway, Suite 1204, Arlington, VA 22202-4302, and to the Office of Management and Budget, Paperwork Project Office, 1215 Jefferson Davis Highway, Suite 1204, Arlington, VA 22202-4302.

wing
ation

0078

1. AGENCY USE ONLY (Leave blank)		2. REPORT DATE	3. REPORT NUMBER
			01 FEB 98 - 30 SEP 01
4. TITLE AND SUBTITLE Dynamic Computational Analyses of Complete Scramjet Engine Modules			5. FUNDING NUMBERS F49620-98-1-0238
6. AUTHOR(S) D. Scott McRae			
7. PERFORMING ORGANIZATION NAME(S) AND ADDRESS(ES) Department of Mechanical and Aerospace Engineering North Carolina State University Raleigh, NC 27695-7910			8. PERFORMING ORGANIZATION REPORT NUMBER
9. SPONSORING/MONITORING AGENCY NAME(S) AND ADDRESS(ES) AFOSR/NM 801 N. Randolph Street Room 732 Arlington, VA 22203-1977			10. SPONSORING/MONITORING AGENCY REPORT NUMBER F49620-98-1-0238
11. SUPPLEMENTARY NOTES			
12a. DISTRIBUTION AVAILABILITY STATEMENT APPROVED FOR PUBLIC RELEASE, DISTRIBUTION UNLIMITED		12b. DISTRIBUTION CODE AIR FORCE OFFICE OF SCIENTIFIC RESEARCH NOTICE OF TRANSMITTAL DTL HAS BEEN REVIEWED AND IS DISTRIBUTION IS UNLIMITED AFR 100-12. DISTRIBUTION IS UNLIMITED	
13. ABSTRACT (Maximum 200 words) The research performed during this period has produced and demonstrated all of the required codes, algorithms and technology needed to analyze dynamically scramjet propulsion modules, both singly and ganged. Cold-flow unstart of a generic hydrocarbon-fuel configuration (tested at NASA langley) due to nozzle backpressure and angle of attack change have been obtained and animated for analysis. An inlet-isolator-combustor hydrogen-fueled configuration tested at the National Aerospace Laboratory in Japan has been simulated dynamically and analysed to determine the cause of flow path destabilization. Finally, an algorithm to allow dynamic adaptation of adjacent blocks has been developed to allow resolution of all of the physics while maintaining conservation between blocks. The codes have not yet been integrated. Follow-on funding will be sought to do so.			
14. SUBJECT TERMS			15. NUMBER OF PAGES 10
20020315 076			16. PRICE CODE
17. SECURITY CLASSIFICATION OF REPORT	18. SECURITY CLASSIFICATION OF THIS PAGE	19. SECURITY CLASSIFICATION OF ABSTRACT	20. LIMITATION OF ABSTRACT



Dynamic Computational Analyses of Complete Scramjet Engine Modules

**D. Scott McRae
Jack R. Edwards**

**Department of Mechanical and Aerospace Engineering
North Carolina State University
Raleigh, North Carolina 27695-7910**

Distribution Unlimited

Prepared for

**Air Force Office of Scientific Research
AFOSR/NM
810 North Randolph Street
Room 732
Arlington, VA 22203-1977**

Review of Objectives:

The research undertaken under this grant has been focused toward performing dynamic, highly accurate computational analyses of ganged-inlet configurations (Project 1, directed by Dr. D.S. McRae) and hypersonic engine component interactions (Project 2, directed by Dr. J.R. Edwards). The specific tasks remain the same as indicated in the original proposal. This document summarizes accomplishments made during the period from Aug. 31, 2000 to September 1, 2001.

II. Status of Effort

The research performed during this period has produced and demonstrated all of the required codes, algorithms and technology needed to analyze dynamically scramjet propulsion modules, both singly and ganged. Cold-flow unstart of a generic hydrocarbon-fuel configuration (tested at NASA Langley) due to nozzle backpressure and angle of attack change have been obtained and animated for analysis. An inlet-isolator-combustor hydrogen-fueled configuration tested at the National Aerospace Laboratory in Japan has been simulated dynamically and analysed to determine the cause of flow path destabilization. Finally, an algorithm to allow dynamic adaptation of adjacent blocks has been developed to allow resolution of all of the physics while maintaining conservation between blocks. The codes have not yet been integrated. Follow-on funding will be sought to do so.

II Accomplishments:

Project 1: Ganged Inlet Analysis

In order to resolve accurately the transients that occur in each inlet/module, a dynamic solution adaptive mesh algorithm is required during transient calculations. A strongly-coupled version of this algorithm has been installed in a perfect gas version of Edwards highly implicit incomplete block factorization / planar Gauss-Seidel algorithm. This algorithm was used to obtain steady solutions for selected conditions and geometry for which experimental results are available. Two different unstart modes were then explored with this code; the first in which unstart was induced by a downstream pressure change and the second in which unstart was induced by a rapid change in inlet angle-of-attack.[1,2]

However, the completion of these examples did not provide all of the capability needed to perform well-resolved ganged module simulations. In order to illustrate the remaining need, it is necessary to recognize that the unstart and dynamic mesh adaptation begins in one module prior to any fluid communication with the adjacent module. This means that the r-refinement mesh adjustment, which is an elliptical process, will begin to move mesh nodes toward the aft section of the module/inlet to resolve the unstart as it proceeds. Since each inlet grid comprises one or more individual blocks, this movement will require mesh nodes, if inter block grid continuity is maintained, to slide onto the splitter plate between the modules, presenting a difficult logical problem. An obvious solution to this problem is to allow the grid to become discontinuous as the grid adapts in one block, thereby relieving the requirement that the grid in the adjacent block be slaved to the adjacent adaptation. An example overlay of two independently adapted block interface grids is shown in Figure (1). The usual problem encountered in this case is that conservation is not preserved in transferring information between blocks. A technique has been developed based on Ramshaws algorithm [3] that allows independent mesh adaptation in each block while maintaining fully conservative grid block interfaces. [4,5]

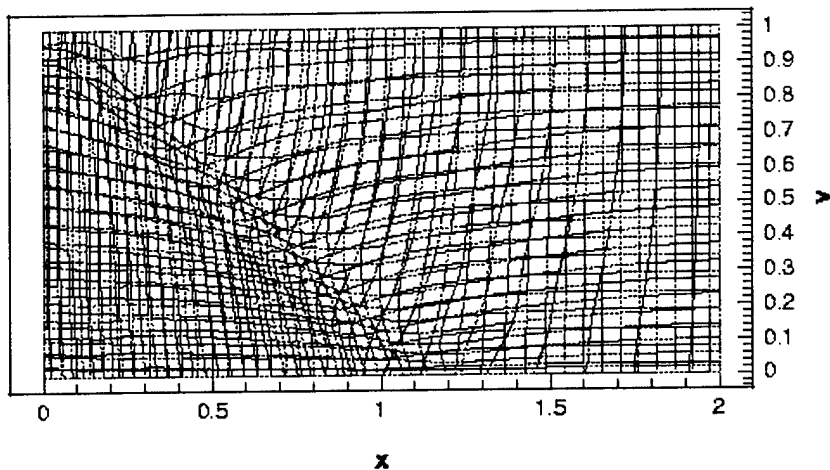

Figure (1) Example of discontinuous block interface meshes after adaptation

Many multiblock solvers use ghost cells (overlap cells taken from the adjacent block) to provide the boundary conditions for computations within each block. These ghost cells are chosen or generated (for instance, in the case of domain decomposition) so that they can provide data for the computation of block interface cell fluxes. The goal is to have the flux computation proceed as if the block boundary did not exist. A communication algorithm is used to transfer data from the interior cells of the adjacent block to the ghost cells. For continuously connected blocks, the communication algorithm involves copying dependent variables from the interior cells of the adjacent block to the ghost cells. In order for two discontinuously connected adjacent blocks to communicate, interior data of the adjacent block must be transferred to the ghost cells using a more complex algorithm. For two 3-D blocks, this data transfer is generally a 3-D problem since the pattern of overlap between the ghost cells and the interior cells of the adjacent block vary in all three dimensions. However, if the ghost cells are constructed appropriately, this data transfer can be reduced to a 2-D problem in computational space by "tiling" the ghost cells from the interface cell geometry. An explanation of the technique follows. The interface of two 3-D blocks is defined by two surface grids, known as the block boundary grids, which are defined on the boundaries of their parent blocks. If the grid blocks are continuous across the interface, then the block boundary grids are identical. If the grid blocks are not continuous across the interface, then a four-sided cell face belonging to the boundary grid on one side of the interface is divided into N polygons by the boundary grid on the other side of the interface. In the general case, a ghost cell would be cut into an arbitrary number of polyhedra by the interior cells of the adjacent block, but if ghost cells are generated properly, then the ghost cells would be divided into N polyhedra, just as their faces are divided into N polygons. This is accomplished by locating a boundary point in the (ξ, η) transformed computational space of the boundary grid on the opposing side of the interface. The ghost nodes are then created by "tiling" the point, which involves using the same ξ and η coordinates while translating by ± 1 in the ζ direction. The (ξ, η, ζ) coordinates are then mapped into the (x, y, z) space to give the physical location of the node. Figure (2) depicts the results of this process.[5]

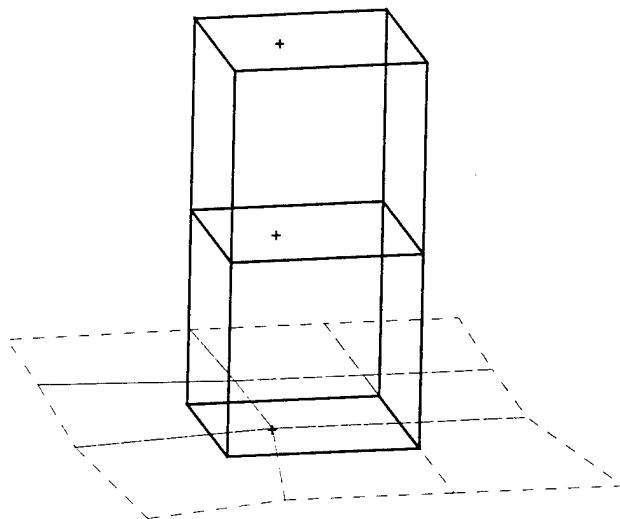

Figure (2) Process of "Tiling" to Form Ghost Nodes

Once all of the nodes have been tiled, the cells are defined by the nodes using either a cell-centered or node-centered finite volume discretization. If ghost cells are constructed in this way, then a single mapping can be derived which transfers dependent variable values to ghost cells of one block from interior cells of an adjacent block. As previously mentioned, this data transfer is simpler if the ghost nodes are tiled in order to generate the ghost cells. If the blocks are labeled one and two, then the mapping that transfers data from block two to block one is $I_{2 \rightarrow 1}$. The mapping $I_{2 \rightarrow 1}$ is generally sparse, since the mapping entry linking interior cells of block two to ghost cells of block one is zero except when the cells overlap.

The Ramshaw algorithm [3] stems from the general equation for the area of a polygon P: This formula allows the area of any polygon to be calculated given the locations of its vertices. Ramshaw provides a systematic version for accomplishing this process. The primary difficulty is that of determining floating point line coincidence in the arbitrarily overlaid mesh. To date, all of the problems have been solved. The results at the interface for an advancing front that crosses two blocks with severely discontinuous interface meshes is shown in Figure (3).[4] This algorithm is now ready for inclusion in the codes described in the following paragraphs and those of Project 2.

The technique used to produce the unstarts is a stand-alone approach for structured grid adaptation, which has been strongly coupled to an implicit perfect-gas solver using a time-accurate, dual time-stepping procedure.[6,7,8] The dual-time stepping approach provides a self-consistent means of correcting the flow solution to correspond with the newly-adapted mesh. The adaptation algorithm is based on the center-of-mass concept introduced by Benson and McRae [9] and is applied in a parametric space, essentially defining a trilinear interpolant for moving grid points in physical space to their new locations. The procedure is suitable for viscous flows on highly-stretched meshes, as cell-aspect ratio and cell skewness effects are incorporated directly into the elliptic equations that govern the solution of the interpolation variables.

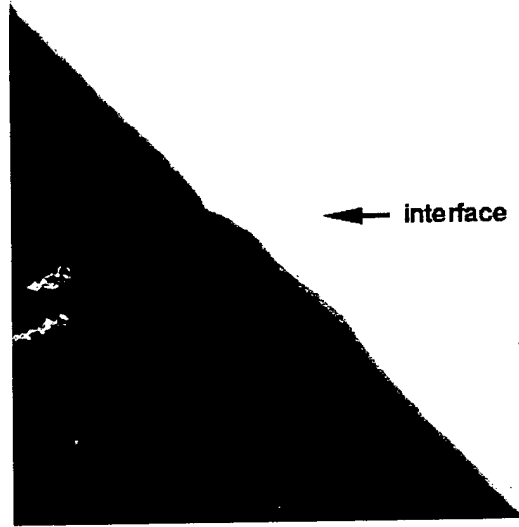

Figure (3) Section of advancing front in two adjacent blocks with discontinuous interface grids.

Defining the interpolation variables corresponding to the computational ξ , η , and ζ directions as p_ξ , p_η , and p_ζ , elliptic equations of the following form are solved in computational space to facilitate adaptation:

$$\left(\frac{|\nabla k|}{|\nabla \xi|}\right)^2 \frac{\partial}{\partial \xi} \left(\omega_k \frac{\partial p_k}{\partial \xi}\right) + \left(\frac{|\nabla k|}{|\nabla \eta|}\right)^2 \frac{\partial}{\partial \eta} \left(\omega_k \frac{\partial p_k}{\partial \eta}\right) + \left(\frac{|\nabla k|}{|\nabla \zeta|}\right)^2 \frac{\partial}{\partial \zeta} \left(\omega_k \frac{\partial p_k}{\partial \zeta}\right) = 0,$$

$k = \xi, \eta, \zeta$

In this, ω_k are weighting functions for the k_{th} interpolant. The major difference between this approach and typical center of-mass methods lies in the non-unity coefficients of the second-derivative terms. These are functions of a stretching factor ($|\nabla k|/|\nabla \xi|$, for example) raised to an orthogonality factor ($|\nabla k \cdot \nabla \xi|/(|\nabla k| |\nabla \xi|)$). These coefficients act in the non-adapting directions to weight the point movement as required to restore acceptable orthogonality.

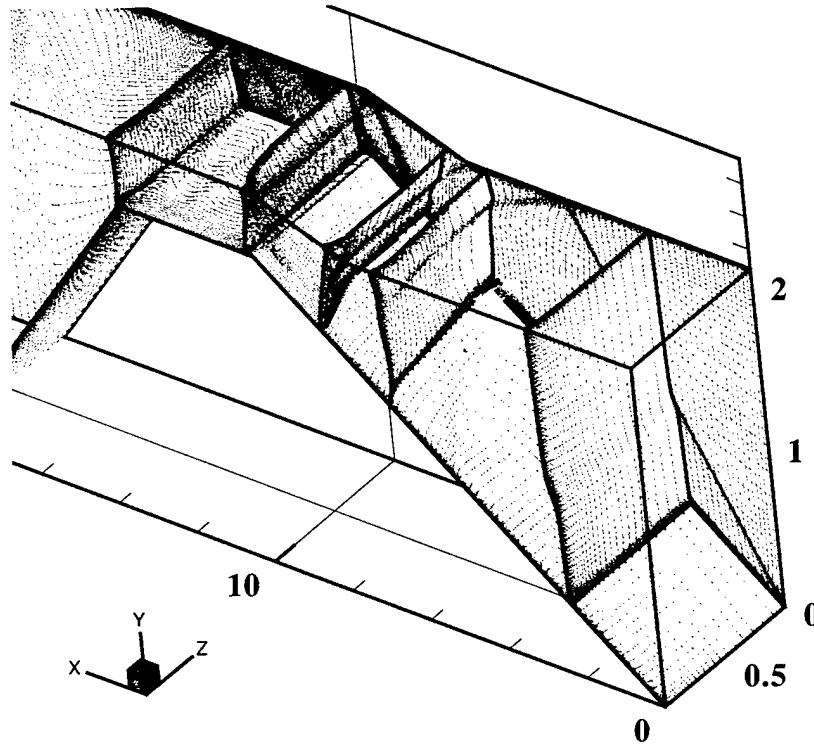

Figure 4: Adapted mesh within scramjet inlet configuration

Reference [6] presents applications of this concept to steady, high-speed inlet flows, while [7,8] discuss its use in dynamic simulations of unstart of a Mach 3.5 scramjet inlet. A snapshot of an adaptive mesh during the unstart process is shown in Figure 4.

Project 2: Hypersonic Engine Component Interactions

Work finalized during the no-cost extension period has resulted in the development of a powerful procedure for conducting unsteady reactive-flow calculations on massively-parallel machines.[10,11,12] This approach combines high resolution upwind differencing strategies with a dual-time stepping (or subiteration) procedure for recovering second order temporal accuracy. A key feature of the approach is the use of highly implicit incomplete block factorization or planar Gauss-Seidel methods to alleviate stability restrictions due to severe grid stretching. This allows the use of physical time steps much larger than the inviscid stability limit, a feature that is particularly important as flowpath responses within complete engine configurations may be very slow, compared to typical characteristic time scales. Computational efficiency is maintained by storing the factorization of system Jacobian matrix in core memory for the particular block (or group of blocks) mapped to a particular processor. After initial transients have been purged, the factorization only needs to be re-evaluated every few iterations, significantly reducing the overall expense. Parallelization of the solver is accomplished through standard domain-decomposition strategies, with communication between processors facilitated by MPI routines. Balakrishnan's 9 species / 24 reaction mechanism [13] is currently used to model hydrogen oxidation. Turbulent effects are handled either by the Spalart-Allmaras one-equation turbulence model or Menter's hybrid $k-\epsilon / k-\omega$ two-equation turbulence model. A more recent addition is a capability for blending Menter's approach for near-wall regions with a large-eddy simulation technique for free-shear and separated flow regions.[14]

The solver has been validated through steady-state simulations of the 3-D shock / hydrogen flame experiments of Driscoll and co-workers [10], among other cases. Dynamic simulations of the response of a complete scramjet inlet-combustor configuration to time-dependent hydrogen fuel injection have also been conducted in two and three dimensions [11,12]. These simulations have focused on resolving the mechanisms leading to flowpath destabilization and eventual inlet unstart due to excessive heat release. Figure 5 presents snapshots of temperature contours at different spanwise planes of a scramjet inlet-isolator-combustor configuration, tested at the National Aerospace Laboratory (NAL), Japan. [15] The sequence of events leading to flowpath destabilization is as follows. Hydrogen fuel is entrained into pockets of separated flow located within the sidewall boundary layer. The fuel then mixes and ignites, leading to flashback (time t_2). The upstream propagation and growth of hot regions of separated flow causes significant blockage of the inviscid core fluid, raising combustor pressure levels and eventually resulting in inlet unstart (time t_3). This mechanism for flowpath destabilization is initiated before the combustor becomes thermally choked at the exit plane.

This simulation was performed on a mesh containing over 2 million nodes, with 15 equations solved per grid point. The simulation was performed on 40 processors of the North Carolina Supercomputing Center's IBM SP-2 and required about 4.5 days of run-time to complete.

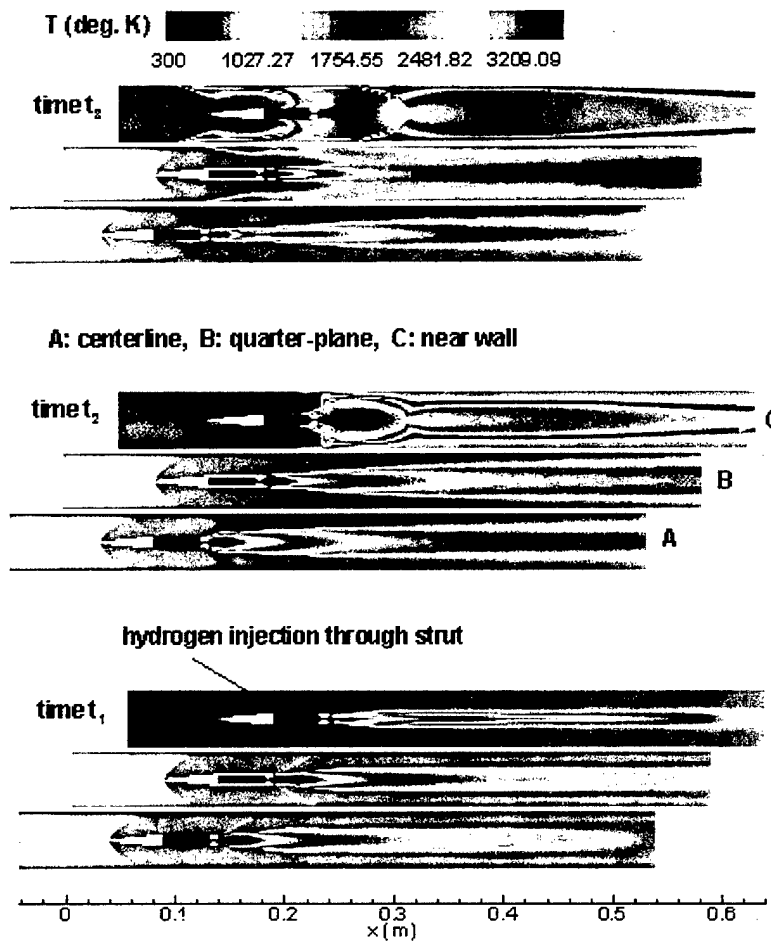

Figure 5: Temperature contours at different spanwise planes during time-dependent scramjet simulation

This technology is currently being applied to the GTX rocket-based combined-cycle engine [16] under development at NASA Glenn Research Center. Research will be focused toward examining the dynamic response of the engine flowfield during mode transition.

Work to be performed during the next reporting period

A final report will be delivered to AFOSR as per grant guidelines and reporting requirements.

References

- [1] Neaves, M.D., McRae, D.S., and Edwards, J.R. "High-Speed Inlet Unstart Calculations using an Implicit Solution-Adaptive Mesh Algorithm," AIAA Paper 2001-0825, Jan. 2001.
- [2] Neaves, M.D. "Analysis of Hypersonic Aircraft Inlets Using Flow Adaptive Mesh Algorithms," Ph.D. Thesis, North Carolina State University, July, 2001.
- [3] Ramshaw, J. D., "Conservative Rezoning Algorithm for Generalized Two-Dimensional Meshes," *Journal of Computational Physics*, Vol. 59, 1985, pp. 193-199.
- [4] Bond, R. B., and McRae, D. S., "A conservative Interblock Communication Algorithm for Dynamically Discontinuous Block Boundary Grids," Proceedings, 7th International Conference on Numerical Grid Generation in Computational Field Simulations, Whistler, British Columbia, Sept. 25-28, 2000, pp. 111-120
- [5] Bond, R.B. "A Conservative Interblock Communication Algorithm for Dynamically-Discontinuous Multiblock Interface Grids," M.S. Thesis, North Carolina State University, June, 2001.
- [6] Neaves, M.D., McRae, D.S., and Edwards, J.R. "High-Speed Flow Calculations using a Three-Dimensional Coupled Implicit Solution-Adaptive Mesh Algorithm," AIAA Paper 99-0665, Jan. 1999.
- [7] Neaves, M.D., McRae, D.S., and Edwards, J.R. "High-Speed Inlet Unstart Calculations using an Implicit Solution-Adaptive Mesh Algorithm," AIAA Paper 2001-0825, Jan. 2001
- [8] Neaves, M.D. "Analysis of Hypersonic Aircraft Inlets Using Flow Adaptive Mesh Algorithms," Ph.D. Thesis, North Carolina State University, July, 2001.
- [9] Benson, R.A. and McRae, D.S. "A Three-Dimensional Dynamic Solution-Adaptive Mesh Algorithm," AIAA Paper 90-1566.
- [10] Roy, C.J. and Edwards, J.R. "Numerical Simulation of a Three-Dimensional Flame / Shock Wave Interaction," *AIAA Journal*, Vol. 38, No. 5, 2000, pp. 745-753.
- [11] McDaniel, K.S. and Edwards, J.R. "Simulation of Thermal Choking in a Model Scramjet Combustor," AIAA Paper 99-3411, June, 1999.
- [12] McDaniel, K.S. and Edwards, J.R. "Three Dimensional Simulation of Thermal Choking in a Model Scramjet Combustor", AIAA Paper 2001-0382, Jan. 2001
- [13] Balakrishnan, G., Smooke, M.D., and Williams, F.A. "A Numerical Investigation of Extinction and Ignition Limits in Laminar Nonpremixed Counterflowing Hydrogen-Air Streams for Both Elementary and Reduced Chemistry," *Combustion and Flame*, Vol. 102, No. 3, 1995, pp. 329-340.
- [14] Fan, T.C., Tian, M., Edwards, J.R., Hassan, H.A., and Baurle, R.A. "Validation of a Hybrid Reynolds-Average / Large-Eddy Simulation Method for Simulating Cavity Flameholder Configurations," AIAA Paper 2001-2929
- [15] Boyce, R.R., Wendt, M., Paull, A., Chinzei, N., Stalker, R.J., and Miyajama, H. "Supersonic Combustion – A Shock Tunnel and Vitiation-heated Blowdown Tunnel Comparison," AIAA Paper 98-0941, Jan. 1998
- [16] Trefny, C.J. "An Air-Breathing Launch Vehicle Concept for Single-Stage-to-Orbit" NASA TM-1999-209089 / AIAA Paper 99-2730, May, 1999.

III. Personnel Supported

1. D. Scott McRae, Professor (partially supported by project)
2. Jack R. Edwards, Associate Professor (partially supported by project)
3. Michael D. Neaves, Graduate Student (associated with project)
4. Ryan B. Bond, Graduate Research Assistant (partially supported by project)
5. Keith S. McDaniel, Graduate Research Assistant (supported by project)

IV. Publications

1. McDaniel, K.S. and Edwards, J.R. "Three Dimensional Numerical Simulation of Thermal Choking in a Model Scramjet Combustor," AIAA Paper 2001-0382, Jan. 2001.
2. Neaves, M.D., McRae, D.S., and Edwards, J.R. "High-Speed Inlet Unstart Calculations using an Implicit Solution-Adaptive Mesh Algorithm," AIAA Paper 2001-0825, Jan. 2001
3. Fan, T.C., Tian, M., Edwards, J.R., Hassan, H.A., and Baurle, R.A. "Validation of a Hybrid Reynolds-Average / Large-Eddy Simulation Method for Simulating Cavity Flameholder Configurations," AIAA Paper 2001-2929.
4. Neaves, M.D. "Analysis of Hypersonic Aircraft Inlets Using Flow Adaptive Mesh Algorithms," Ph.D. Thesis, North Carolina State University, July, 2001.
5. McDaniel, K.S. "Three-Dimensional Simulation of Time-Dependent Scramjet Isolator /Combustor Flowfields Implemented on Parallel Architectures, M.S. Thesis, North Carolina State University, December, 2000.
6. Bond, R.B. "A Conservative Interblock Communication Algorithm for Dynamically-Discontinuous Multiblock Interface Grids," M.S. Thesis, North Carolina State University, June, 2001.
7. Bond, R. B., and McRae, D. S., " A conservative Interblock Communication Algorithm for Dynamically Discontinuous Block Boundary Grids," Proceedings, 7th International Conference on Numerical Grid Generation in Computational Field Simulations, Whistler, British Columbia, Sept. 25-28,2000, pp. 111-120

V. Interactions/ Consultations/ Transitions

Participation / presentation at meetings, conferences, etc

D. S. McRae, R. B. Bond, 7th International Conference on Numerical Grid Generation in Computational Field Simulations, Whistler, British Columbia, Sept. 25-28,2000

D. S. McRae, J.R. Edwards, M.D. Neaves – 38th Aerospace Sciences Meeting, Reno, NV, January, 2001

J.R. Edwards, D.S. McRae – 15th AIAA CFD Conference, Anaheim, CA, June, 2001

Consultations

Robert Baurle, Taitech, Inc., Wright-Patterson AFB, OH, in reference to hybrid LES / RANS simulations for cavity flameholder configurations

Transitions

Michael D. Neaves completed the requirements for his Doctoral degree in July, 2001. He is currently employed at the Naval Surface Warfare Center, Dahlgren Division, Panama City, FL.

Ryan B. Bond completed the requirements for his Master of Science degree in June, 2001. He has entered the Ph.D. program at NCSU.

Keith S. McDaniel received his Master of Science degree in May, 2001. He is currently employed at CFD Research Corporation, Huntsville, AL.

V. New Discoveries

None, except as indicated in this report.

VI. Honors and Awards

Ryan B. Bond was awarded the inaugural Ziglar Fellowship for Graduate Study in Aerospace Engineering at NCSU.