

Noncooperative Target Classification of Forward Area Air Defense Threats

March 1998

Authors:

Wilfred Otaguro
Boeing Co.
Huntington Beach, CA

Chyau Shen
Naval Air Warfare Center
Patuxent River, MD

Lee Pratt
Aviation & Missile Command
Huntsville, AL

Captain Kathleen Gainey
Air Defense Battle Lab Support Element
El Paso, TX

ABSTRACT

The Army Advanced Concept & Technology II (ACT II) program demonstrated an enhanced combat identification capability to the Forward Area Air Defense System by measuring the unique vibrational signatures of airborne targets as discriminants. The engagements were conducted during the Air Defense Battle Lab Support Element's Live Experiment II Exercise in which fixed-wing aircraft, rotor-wing aircraft, and a simulated unmanned air vehicle were engaged, classified, and identified as friend or foe.

The results of realistic operational engagements involving "slew to cue" from the Sentinel radar to acquire, classify, and identify airborne targets beyond visual range, using passive, high-resolution, infrared cameras to detect and track targets and a coherent detection ladar to classify, will be presented with video of the actual field engagements of multiple targets. Descriptions will be given of a carbon dioxide ladar, which was used to measure the microdoppler signatures, and the Boeing Multi-functional Optical System Testbed used to provide the highly stabilized, optical beam director / tracker functions.

Implications of engagement doctrine, based on (1) using a combination of the target's track file fused from multiple sources and (2) noncooperative target classification using platform vibration for determining combat identification, will be discussed.

REPORT DOCUMENTATION PAGE

Form Approved OMB No.
0704-0188

Public reporting burden for this collection of information is estimated to average 1 hour per response, including the time for reviewing instructions, searching existing data sources, gathering and maintaining the data needed, and completing and reviewing this collection of information. Send comments regarding this burden estimate or any other aspect of this collection of information, including suggestions for reducing this burden to Department of Defense, Washington Headquarters Services, Directorate for Information Operations and Reports (0704-0188), 1215 Jefferson Davis Highway, Suite 1204, Arlington, VA 22202-4302. Respondents should be aware that notwithstanding any other provision of law, no person shall be subject to any penalty for failing to comply with a collection of information if it does not display a currently valid OMB control number. PLEASE DO NOT RETURN YOUR FORM TO THE ABOVE ADDRESS.

1. REPORT DATE (DD-MM-YYYY) 01-03-1998	2. REPORT TYPE Conference Proceedings	3. DATES COVERED (FROM - TO) xx-xx-1998 to xx-xx-1998
---	--	--

4. TITLE AND SUBTITLE Noncooperative Target Classification of Forward Area Air Defense Threats Unclassified	5a. CONTRACT NUMBER
	5b. GRANT NUMBER
	5c. PROGRAM ELEMENT NUMBER

6. AUTHOR(S) Otaguro, Wilfred ; Shen, Chyau ; Pratt, Lee ; Gainey, Kathleen ;	5d. PROJECT NUMBER
	5e. TASK NUMBER
	5f. WORK UNIT NUMBER

7. PERFORMING ORGANIZATION NAME AND ADDRESS Boeing Co. Huntington Beach, CAxxxxx	8. PERFORMING ORGANIZATION REPORT NUMBER
--	--

9. SPONSORING/MONITORING AGENCY NAME AND ADDRESS Director, CECOM RDEC Night Vision and Electronic Sensors Directorate, Security Team 10221 Burbeck Rd. Ft. Belvoir, VA22060-5806	10. SPONSOR/MONITOR'S ACRONYM(S)
	11. SPONSOR/MONITOR'S REPORT NUMBER(S)

12. DISTRIBUTION/AVAILABILITY STATEMENT
APUBLIC RELEASE

13. SUPPLEMENTARY NOTES
See Also ADM201041, 1998 IRIS Proceedings on CD-ROM.

14. ABSTRACT
The Army Advanced Concept & Technology II (ACT II) program demonstrated an enhanced combat identification capability to the Forward Area Air Defense System by measuring the unique vibrational signatures of airborne targets as discriminants. The engagements were conducted during the Air Defense Battle Lab Support Element's Live Experiment II Exercise in which fixed-wing aircraft, rotor-wing aircraft, and a simulated unmanned air vehicle were engaged, classified, and identified as friend or foe.

15. SUBJECT TERMS

16. SECURITY CLASSIFICATION OF:	17. LIMITATION OF ABSTRACT	18. NUMBER OF PAGES	19. NAME OF RESPONSIBLE PERSON
a. REPORT Unclassified	Public Release	10	Fenster, Lynn lfenster@dtic.mil
b. ABSTRACT Unclassified			
c. THIS PAGE Unclassified			

	19b. TELEPHONE NUMBER
	International Area Code
	Area Code Telephone Number
	703767-9007
	DSN
	427-9007

1. Introduction

The Forward Area Air Defense (FAAD) System has a need to classify and identify targets detected by the Sentinel radar at beyond visual range (BVR) as hostile, unknown, or friendly. Targets at BVR will be unresolved to existing tactical imaging cameras and will appear as dots on the operator's display which will make classification/identification of these targets using size and shape impossible.

Current Army air defense doctrine requires that FAAD Short Range Air Defense (SHORAD) fire units have visual verification of threat targets to eliminate fratricide. This requirement limits the effective range of SHORAD fire units to distances shorter than the maximum range of their weapons.

The Objective of this Army Advanced Concept & Technology II (ACT II) program is to demonstrate the capability of a coherent detection ladar to classify airborne targets at BVR using the target's vibrational signatures caused by the aircraft's power plant and to perform BVR identification (ID) as an adjunct to the Sentinel radar.

A Multi-Functional Optical System (MFOS) Testbed (Figure 1-1) which was developed, maintained, and operated by Boeing (formerly McDonnell Douglas), and a coherent

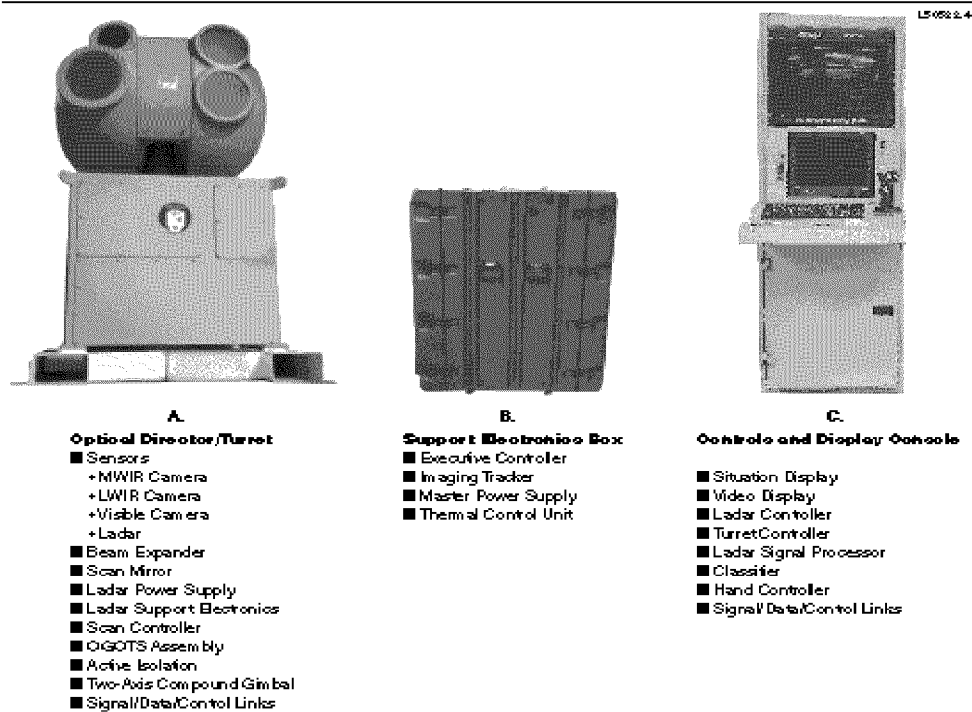

Figure 1-2. The MFOS test-bed elements for Air-Defense provides proven performance

Figure 1-1 MultiFunctional Optical System Testbed

detection ladar, which was developed by Boeing (formerly Rockwell) for the Naval Air Warfare Center - Aircraft Division, Patuxent River, were provided to the Army by Boeing and NAWC in support of this contract. The MFOS consists of a Mid-Wave Infrared (MWIR) camera, a Long-Wave Infrared (LWIR) camera, a visible CCD camera, and a carbon dioxide (CO₂) ladar, all of which are mounted on a highly stabilized gimbal.

The field test was conducted at the Ft Bliss Air Defense Battle Lab Support Element's (AD BLSE) SHORAD range. Fixed-wing (jet, several propeller aircraft) and rotor-wing aircraft were provided as airborne targets by the AD BLSE and engaged by the MFOS testbed. The targets flew typical operational patterns for attack and surveillance missions. The Sentinel radar detected and tracked these targets. The angular bearings of all the targets being tracked by the Sentinel radar were used to selectively cue the MFOS. After performing slew to the Sentinel cue, the MFOS testbed detected, tracked, and classified all these targets at BVR.

The results of this test clearly demonstrated how an integrated coherent detection radar on a stabilized gimbal can provide an adjunct to the FAAD SHORAD elements for BVR classification and identification.

2. Objective

The objective of this Advanced Concept & Technology II (ACT II) program was to classify airborne targets in realistic engagement scenarios at BVR using a coherent detection radar to measure the target's vibrational signatures caused by the aircraft's power plant. This classification, when used with other target metrics, provided combat identification.

3. Approach

Using cues from a Sentinel radar, the MFOS Testbed performed a "Slew to Cue". The imaging camera reacquired and tracked the target handed over from the radar. The radar, which is boresighted to the tracking camera, measured its microdoppler (vibrational) signature. This vibrational signature, which is characteristic of the target's power plant, is used to classify the target. This platform classification is used with other target metrics to identify the target as friend or foe.

4. Live Experiment II

The ACT II Enhanced Combat ID engagements were integrated into AD BLSE's Live Experiment II field tests which were being conducted from 1 - 12 December 1997 at the SHORAD Range, New Mexico.

4.1. Test Configuration

As part of the Live Experiment II, the Sentinel radar was connected to FAAD C2 which was connected through the Enhanced Position Location Reporting System (EPLRS) network to the MFOS as shown in Figure 4.1-1.

The MFOS testbed was located near the FAAD fire units (Avenger and Bradley Stinger Fighting Vehicles) with the Sentinel radar located 5 kilometers away. The targets flew their patterns at ranges from 0 to 20 kilometers in a 90° sector directly east of the test site. This engagement configuration is shown in Figure 4.1-2.

4.1.1.Sentinel Radar

The FAAD Sentinel radar, which is the key air surveillance and target acquisition/tracking sensor for FAAD weapons, is an advanced three-dimensional battlefield air defense radar that uses modern phased-array antenna technology. It automatically detects, tracks, and reports airborne targets to the FAAD weapon systems. It sent the target's metrics to the FAAD C2 node which provided the target cues to MFOS via the EPLRS network. During these tests, up to five targets were being tracked by the Sentinel radar and were handed over to MFOS. It had an update rate of 2 seconds and a bearing accuracy of 0.2°.

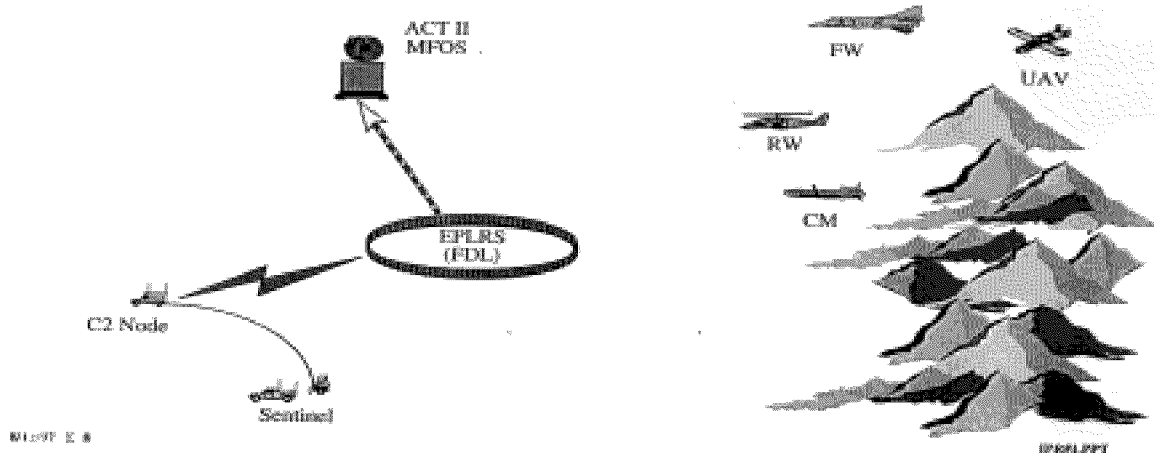

Figure 4.1-1 Sentinel to MFOS Connectivity

4.1.2.Multi-Functional Optical System (MFOS)

The MFOS testbed (Figure 1-1) was developed by Boeing with advanced passive and active electro-optical sensors provided as government-furnished equipment (GFE) from the Naval Air Warfare Center-Aircraft Division: Pax River. The MFOS tracks unresolved airborne targets using a high-resolution imaging camera. A coherent ladar is boresighted to the passive track point provided by the imaging camera and illuminates the target to measure the vibrational signature caused by the target's power plant. The passive and active sensor specifications are listed in Table I, and the optical director / turret specifications are listed in Table II.

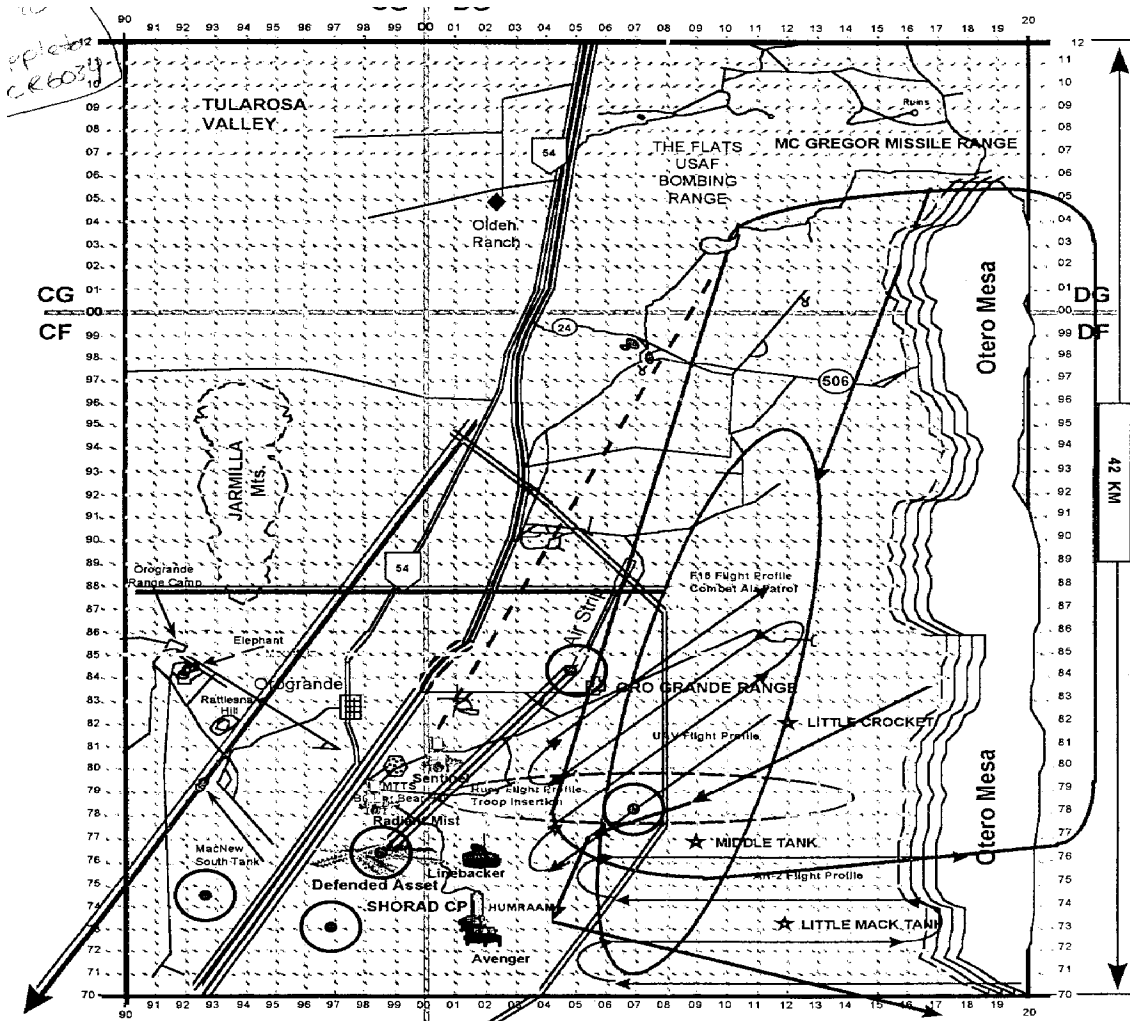

Figure 4.1-2 Field Test Configuration

Table I. Sensor subsystem specifications

Sensor	Performance Area	Specification
Visible camera	FOV	2 degrees
	Resolution	50 microradians
	Aperture	4.0 in. diameter
	Illuminance range	1 to 100 lm/m ²
MWIR camera	HgCdTe	320 x 240 array
	FOV	2 degrees

	Resolution Aperture NEI	122 microradians 6 in. 1E-15 W/cm ²
LWIR camera	FOV Resolution Aperture NEI	2.8 degrees 170 microradians 6.6 in. diameter 1E-13 W/cm ² (approximately)
Ladar	Aperture Power Weight Volume Beam control Beam control accuracy Noise	6 in. 10 W <100 lb 2 ft ³ agile, adjustable 3 microradians <10 mm per second

Table II Optical Director/Turret subsystem characteristics

Performance Area	Specification
Azimuth angular coverage	±190 degrees
Elevation angular coverage	±30 degrees
Slew/Rate/Acceleration	45°/sec and 45°/sec ²
Stabilization	20 microradians
Tracking resolution	<100 microradians
Boresight alignment	<100 microradians
Narcissus	<48 dB

The measured microdoppler (vibrational) discriminants caused by the power plants of the airborne target (Figure 4.1.2-1) are used to classify/identify the targets.

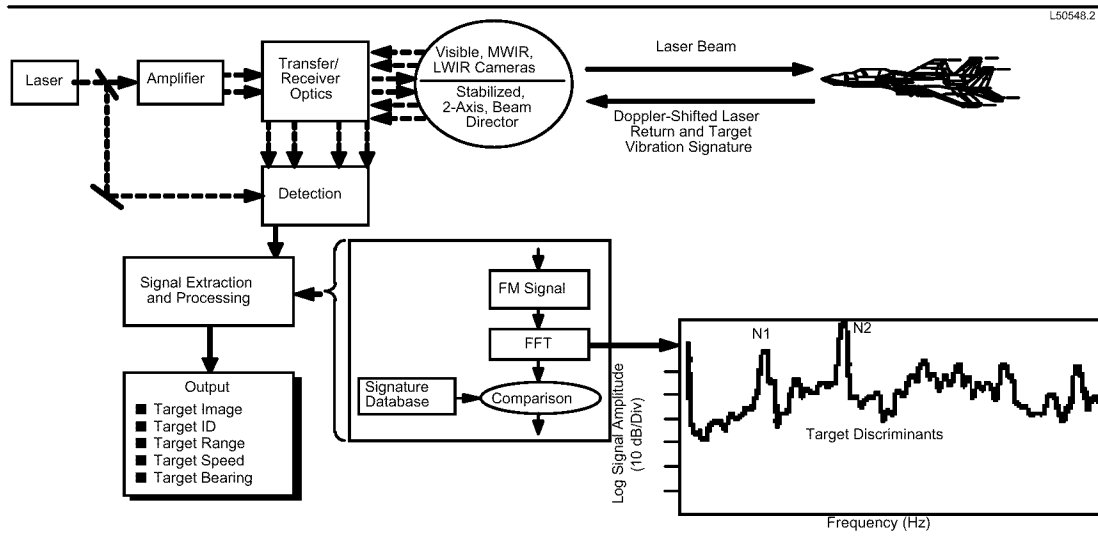

Figure 4.1.2-1 Functional Diagram of MFOS microdoppler measurements

4.1.3.EPLRS / HTU

The MFOS was connected to the Forward Area Air Defense Command and Communication (FAAD C2) system through the Enhanced Position Location Reporting System (EPLRS) that was provided GFE by the AD BLSE . The Sentinel tracks and target metrics were displayed on a Handheld Terminal Unit (HTU) providing target range, speed, azimuth angle, elevation angle, and altitude. Using this information, MFOS performed a slew to cue to acquire and track the target. MFOS did not provide any information back onto the EPLRS network.

4.2. Test Results

4.2.1.Microdoppler Signatures

Live Ex II provided realistic, FAAD engagement scenarios against multiple airborne threats. These threats included rotor and fixed-wing targets. The microdoppler signatures of these targets were measured and documented during the airborne engagements. The following sections show the LOFAR Gram (frequency of signal vs time; strength of the signal is shown by the darkness of the line) of the microdoppler signatures of the targets engaged. The vertical scale is time, and the horizontal scale is frequency in Hertz.

4.2.1.1. Rotor-wing

The rotor-wing microdoppler signature shown in Figure 4.2.1.1-1 represents the main rotor frequency at 24.5 Hz.

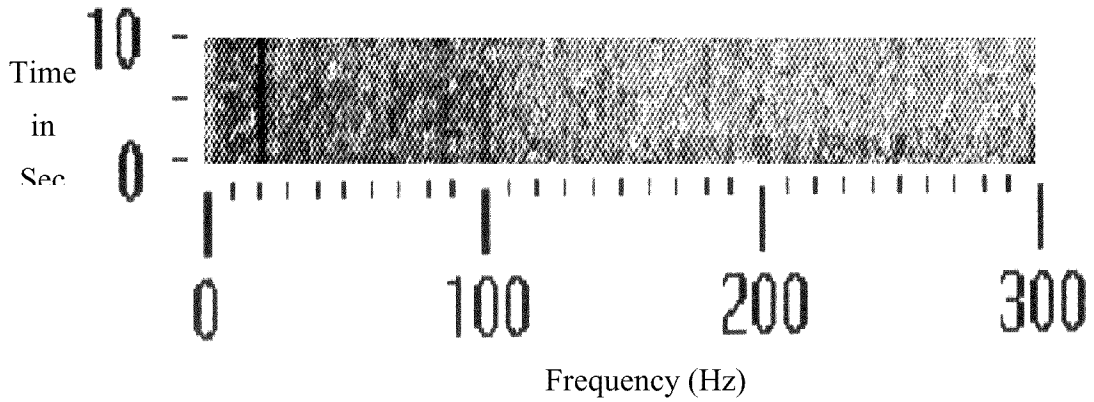

Figure 4.2.1.1-1 LOFAR Gram of Rotor-wing Target

4.2.1.2. Fixed-wing

The fixed-wing jet microdoppler signature shown in Figure 4.2.1.2-1 represents microdoppler frequencies at 187 and 257 Hz.

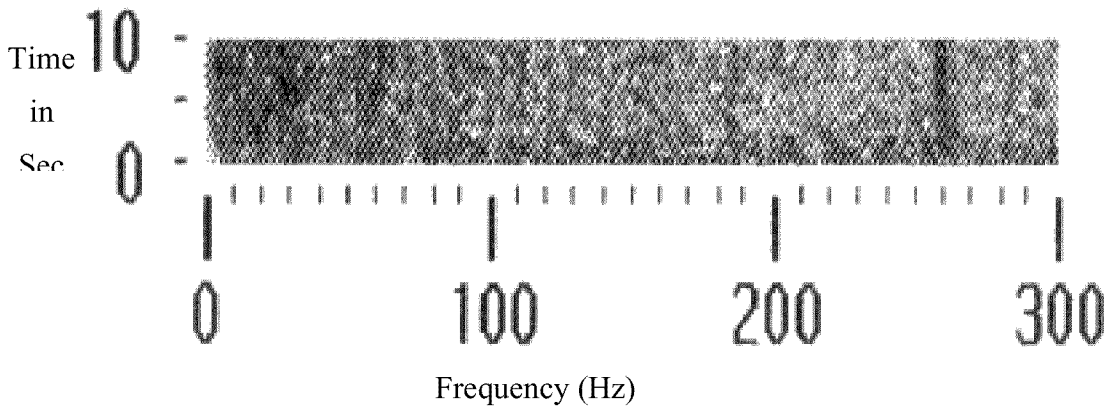

Figure 4.2.1.2-1 LOFAR Gram of Fixed-wing Jet Target

The fixed-wing Bi-Plane's microdoppler signature (Figure 4.2.1.2-2) which shows microdoppler frequencies at 31, 62, and 93 Hz. Structural / noise frequencies are seen at 150 Hz.

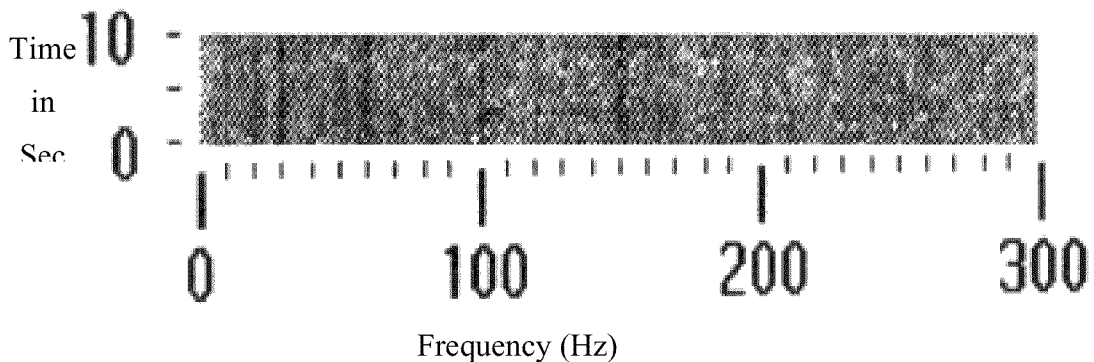

Figure 4.2.1.2-2 LOFAR Gram of Fixed-wing Bi-Plane Target

Boeing's checkout aircraft is a Piper Cherokee. Its microdoppler signature (Figure 4.2.1.1.2-3) shows its microdoppler frequencies at 75, 150, and 225 Hz.

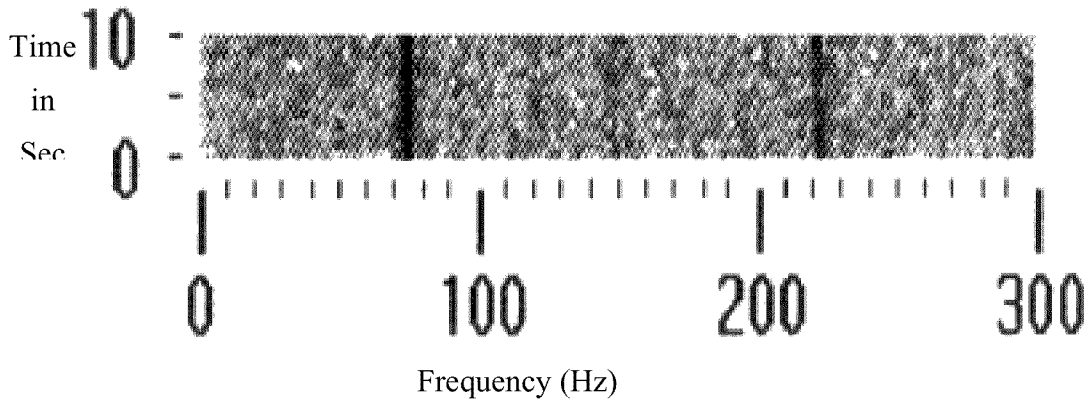

Figure 4.2.1.2-3 LOFAR Gram of Fixed-wing Piper Cherokee Target

The simulated unmanned air vehicle (UAV) microdoppler signature, (Figure 4.2.1.2-4), shows the main rotor frequency at 82 Hz, with structural and noise lines at 29, 56, and 109 Hz. A Long EZ aircraft was used to simulate the UAV.

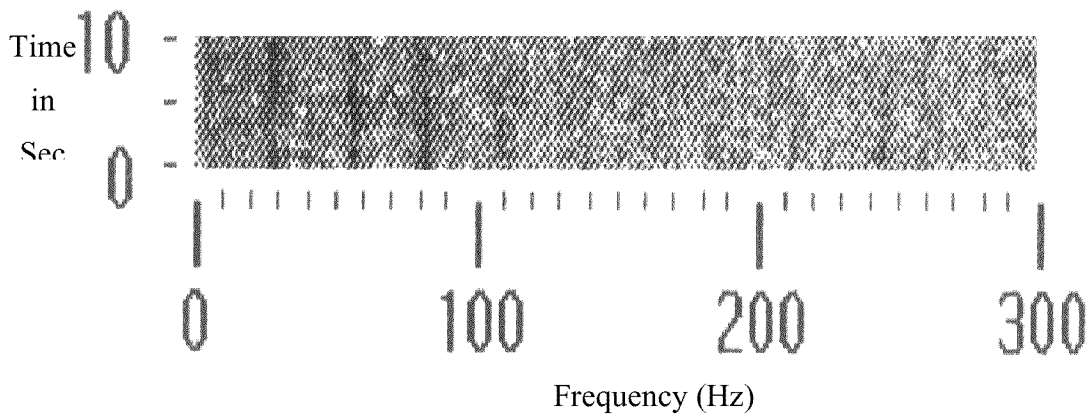

Figure 4.2.1.2-4 LoFar Gram of Fixed-wing Simulated UAV (Long EZ) Target

4.3. FAAD Results

The results of this field test clearly demonstrated a microdoppler ladar adjunct to the Sentinel radar that is capable of providing non-cooperative target classification / identification at BVR (> 10km).

Slew-to-cue from the Sentinel radar to MFOS was demonstrated. The key to its operational effectiveness is the minimized time (latency) between Sentinel detection and microdoppler classification. This latency can be minimized by reducing the coverage of each microdoppler ladar to selective threat corridors.

Prioritizing of threats based on the threat's classification, range, direction, and speed will determine the engagement sequence used by the weapon systems.

Participation in the next All Service Combat Identification and Evaluation Team (ASCIET) Exercise is planned to evaluate the MFOS microdoppler classification/identification of airborne targets under more realistic operational conditions.