

REPORT DOCUMENTATION PAGE

Public reporting burden for this collection of information is estimated to average 1 hour per response, including the time for reviewing data needed, and completing and reviewing this collection of information. Send comments regarding this burden estimate or any other aspect of this collection of information, including suggestions for reducing this burden to Department of Defense, Washington Headquarters Services, Directorate for Information Operations and Reports (0704-0188). Respondents should be aware that notwithstanding any other provision of law, no person shall be subject to any penalty for failing to provide information unless it is specifically required by law. **PLEASE DO NOT RETURN YOUR FORM TO THE ABOVE ADDRESS.**

AFRL-SR-BL-TR-02-

3 the
cing
2-
antly

1. REPORT DATE (DD-MM-YYYY)

01-12-2001

2. REPORT TYPE

Final Report

0055

3370 - 30-09-2001

4. TITLE AND SUBTITLE

Mechanism of Al Alloy Corrosion and the Role of Chromate Inhibitors

5a. CONTRACT NUMBER

5b. GRANT NUMBER

F49620-96-1-0479

5c. PROGRAM ELEMENT NUMBER

61103D

5d. PROJECT NUMBER

3484

5e. TASK NUMBER

RS

5f. WORK UNIT NUMBER

6. AUTHOR(S)

Gerald S. Frankel

8. PERFORMING ORGANIZATION REPORT NUMBER

N/A

7. PERFORMING ORGANIZATION NAME(S) AND ADDRESS(ES)

The Ohio State University
477 Watts Hall
2041 College Rd.
Columbus, OH 43210

9. SPONSORING / MONITORING AGENCY NAME(S) AND ADDRESS(ES)

Lt. Col. Paul Trulove, PhD
AFOSR/NL
801 North Randolph Street
Room 732
Arlington VA 22203-1977

10. SPONSOR/MONITOR'S ACRONYM(S)

11. SPONSOR/MONITOR'S REPORT NUMBER(S)

12. DISTRIBUTION / AVAILABILITY STATEMENT

Approved for Public Release, Distribution Unlimited

AIR FORCE OFFICE OF SCIENTIFIC RESEARCH (AFOSR)
NOTICE OF TRANSMITTAL DTIC. THIS TECHNICAL REPORT
HAS BEEN REVIEWED AND IS APPROVED FOR PUBLIC RELEASE
LAW AFR 100-12. DISTRIBUTION IS UNLIMITED.

13. SUPPLEMENTARY NOTES

14. ABSTRACT

This report summarizes a 5-year MURI program focused on the mechanism of corrosion inhibition of Al alloys by chromates. This involves understanding how chromate acts in organic primer coatings, in conversion coatings on Al alloys, and in solution as a dissolved species. Other work was concerned with the mechanisms of Al alloy corrosion even in the absence of chromate. The findings have addressed the formation mechanism of Cr-containing surface layers, the structure and composition of those layers, the release of chromate from those layers, the migration of chromate to active corrosion sites, and the mechanism by which chromate inhibits the corrosion. Cr-containing films were found to be an effective cathodic inhibitor, even at monolayer amounts. Such films also inhibited breakdown, and are therefore also anodic inhibitors.

15. SUBJECT TERMS

Aluminum Alloys, Corrosion, Chromium (VI), Chromate, Conversion Coating

16. SECURITY CLASSIFICATION OF:

Unclassified

17. LIMITATION OF ABSTRACT

18. NUMBER OF PAGES

83

19a. NAME OF RESPONSIBLE PERSON

a. REPORT

b. ABSTRACT

c. THIS PAGE

19b. TELEPHONE NUMBER (include area code)

AFOSR Multidisciplinary University Research Initiative

Mechanism of Al Alloy Corrosion and the Role of Chromate Inhibitors

Air Force Office of Scientific Research
Contract No. F49620-96-1-0479

Final Report
December 1, 2001

prepared by:

Gerald S. Frankel
The Ohio State University
Fontana Corrosion Center



Co-Principal Investigators:

Clive R. Clayton, State University of New York at Stony Brook
Richard D. Granata, Florida Atlantic University
Martin W. Kendig, Rockwell Science Center
Hugh S. Isaacs, Brookhaven National Laboratories
Richard L. McCreery, The Ohio State University
Martin Stratmann, Max-Planck-Institut fuer Eisenforschung

20020221 070

Table of Contents

1	FOREWORD	4
2	OBJECTIVES	4
3	PERSONNEL SUPPORTED	6
3.1	PRINCIPAL INVESTIGATORS.....	6
3.2	OTHER PERSONNEL.....	6
4	EXECUTIVE SUMMARY	9
5	ACCOMPLISHMENTS	11
5.1	TECHNICAL SUMMARY OF THE MCCREERY GROUP AT OSU	11
5.1.1	<i>Structure and formation of CCC films.</i>	12
5.1.2	<i>Release of Cr^{VI} from CCC to effect “self healing”</i>	14
5.1.3	<i>In-situ Raman Microscopy of Chromate Effects on Aluminum Alloy</i>	16
5.2	TECHNICAL SUMMARY OF THE FRANKEL GROUP AT OSU.....	20
5.2.1	<i>AFM-based studies</i>	20
5.2.2	<i>Artificial crevice studies</i>	23
5.2.3	<i>Electrochemical Quartz Crystal Microbalance (EQCM) studies</i>	24
5.2.4	<i>Chromate release studies</i>	25
5.2.5	<i>References</i>	25
5.3	TECHNICAL SUMMARY OF THE GROUP AT ROCKWELL SCIENCE CENTER.....	27
5.3.1	<i>Background</i>	27
5.3.2	<i>Scientific Goals</i>	27
5.3.3	<i>Experimental Approaches</i>	27
5.3.4	<i>Summary of Results</i>	29
5.3.5	<i>Conclusions</i>	31
5.3.6	<i>References</i>	32
5.4	TECHNICAL SUMMARY OF THE GROUP AT BROOKHAVEN NATIONAL LAB.....	35
5.4.1	<i>Behavior of Passive Films on Al in Different Aqueous Environments</i>	35
5.4.2	<i>The Source of Electrochemical Noise During Pitting Corrosion</i>	36
5.4.3	<i>In situ XANES Study of Chromate Conversion Coatings Formation on Al and Al Alloys</i>	37
5.5	TECHNICAL SUMMARY OF THE GROUP AT STATE UNIVERSITY OF NEW YORK AT STONYBROOK	39
5.5.1	<i>Radiation damage of chromate conversion coatings during x-ray photoelectron spectroscopy</i>	39
5.5.2	<i>Studies on the Surface Preparation of AA2024-T3</i>	40
5.5.3	<i>Effect of Surface Pretreatments of AA2024-T3 on the Composition of Chromate Conversion Coatings</i>	41

5.5.4	<i>Composition of Intermetallic Compounds, Thin Film Analogs of Intermetallic Constituents and Chromate Conversion Coatings Formed on them and Effects of aging on these coatings</i>	43
5.5.5	<i>Bipolar Mechanism for Chromate-Induced Repassivation of Active Sites on Aluminum and Repassivation behavior of Chromate Conversion Coated AA2024-T3</i>	46
5.6	TECHNICAL SUMMARY OF THE GROUP AT UNIVERSITY OF ELANGEN AND MAX PLANCK INSTITUTE	48
5.6.1	<i>Filiform corrosion experiments – Tracking FFC</i>	49
5.6.2	<i>Filiform corrosion experiments – Atmospheric Changes</i>	49
5.6.3	<i>Development of Al-Cu Model Samples</i>	52
5.7	TECHNICAL SUMMARY OF THE GROUP AT LEHIGH/FLORIDA ATLANTIC UNIVERSITY	55
5.7.1	<i>Electrochemical Impedance Spectroscopy – Static Immersion Studies</i> ..	55
5.7.2	<i>Electrochemical Impedance Spectroscopy – Cyclic Exposure Studies</i> ..	56
5.7.3	<i>Adhesion Studies – Cyclic Exposure</i>	56
5.7.4	<i>Adhesion Studies – Static Exposure</i>	57
5.7.5	<i>PALS</i>	58
6	PUBLICATIONS	61
6.1	PEER REVIEWED PUBLICATIONS	61
6.2	PUBLICATIONS IN CONFERENCE PROCEEDINGS	65
7	INTERACTIONS/TRANSITIONS	71
7.1	PARTICIPATION/PRESENTATION AT MEETINGS, CONFERENCES, SEMINARS	71
7.2	CONSULTATIVE AND ADVISORY FUNCTIONS	81
7.3	TRANSITIONS	81
8	NEW DISCOVERIES, INVENTIONS, AND PATENT DISCLOSURES	82
9	HONORS/AWARDS	82

1 Foreword

This report summarizes research performed for the Air Force Office of Scientific Research under Contract No. F49620-96-1-0479, "Mechanism of Al Alloy Corrosion and the Role of Chromate Inhibitors." The project was funded by AFOSR through the Multidisciplinary University Research Initiative program. The contract began on September 30, 1996, and ran for a total of five years. The Principal Investigator was Prof. Gerald S. Frankel, Department of Materials Science and Engineering, The Ohio State University. The AFOSR program manager initially was Maj. Hugh DeLong, PhD, but Lt. Col. Paul Trulove, PhD took over in about 1998. The co-PIs include Prof. Clive Clayton, State University of New York at Stony Brook; Prof. Richard Granata, formerly at Lehigh University and now with Florida Atlantic University; Dr. Martin Kendig, Rockwell Science Center; Dr. Hugh S. Isaacs, Brookhaven National Laboratories; Prof. Richard McCreery, The Ohio State University; and Prof. Martin Stratmann, formerly at Friedrich-Alexander University in Erlangen and now at Max-Planck-Institut fuer Eisenforschung in Duesseldorf. This team was assisted by a number of undergraduate and graduate students, post-doctoral researchers, and colleagues.

2 Objectives

Chromates are extremely effective and widely used as corrosion inhibitors for high strength Al alloys in aerospace applications. A combination of pressures, including environmental regulations on the use and handling of chromates, increased service life requirements of the fleet of airplanes, and the cost of preventive maintenance, has motivated the US Air Force to invest in efforts to find improved and environment-friendly methods of corrosion protection. A number of chromate-replacement systems have been developed in recent years, but none are as effective as chromate at inhibiting corrosion, especially for the high-strength Al alloys commonly used in aerospace applications. An Air Force Blue Ribbon Advisory Panel on Aircraft Coatings concluded that developing a better understanding of the mechanisms of aluminum corrosion and chromate inhibition is a top priority and a prerequisite for the development of a successful replacement. As a result of various research efforts over many years, considerable understanding of the mechanisms of Al corrosion and the inhibition provided by chromate has already been developed. However, several key unresolved issues remain.

An international consortium of researchers from academia, industry and a national lab was formed as part of this AFOSR Multidisciplinary University Research Initiative program to address and resolve those issues regarding the mechanism of chromate inhibition. The project formally began on September 30, 1996. It should be noted that developing a chromate replacement was not the goal of this project. On the other hand, it is clear that the many efforts underway at a number of institutions to develop a conversion-coating/paint system to replace the standard chromate-containing protective systems are seeking guidance in making their systems more chromate-like. Most often that implies the desire to add functionality similar to the purported "self-healing" characteristic of chromates. It is considered that chromate can migrate from a reservoir somewhere in the conversion coating or primer to a distant active

exposed site on the sample surface to inhibit the corrosion attack. A working hypothesis for why chromate is so effective an inhibitor is that it is a very soluble, higher-valent cation of an element with a lower-valent ion (Cr^{3+}) that is very poorly soluble and forms a protective film.

One goal of this project was to fully characterize and understand this migration and healing process. This involves understanding how chromate acts in organic primer coatings, in conversion coatings on Al alloys, and in solution as a dissolved species. Therefore, the work of this MURI team was loosely divided into those three realms, although there is considerable overlap. A fourth category on technique development, sample preparation and characterization contains critically important work that is not directly related to chromates. The perspective of this team was not limited, however, by this one view of the role of chromates. Other possible influences of chromates in organic coatings and conversion coatings were also investigated, including the effect on cathodic kinetics, the effect of the chromate conversion coating (CCC) on the zeta potential of the surface, the effect on ion rectification, the effect on adhesion and protectiveness of organic coatings, pH buffering, rapid kinetics of coating deposition, and passivation of intermetallics.

Therefore, the work in this program addressed the following key questions related to the inhibition of Al dissolution by chromate:

1. What is the structure, composition, and formation mechanism of CCCs?
2. How and at what rate is chromate released from CCCs and primers?
3. Does chromate in CCCs and primers have a role other than dissolving and migrating to corrosion sites?
4. Does chromate in a primer affect the properties of the primer?
5. What is the speciation of chromium ions in solution?
6. How do chromates inhibit localized corrosion?
7. How do they affect anodic and cathodic kinetics of the Al matrix and common intermetallic particles?
8. How do they affect passivation and passive film properties?
9. Does chromate improve the adhesion of organic coatings?

A broad range of work has been carried out during this program. This document summarizes all of the activities during the whole period of the project, from October 1, 1996 through September 30, 2001.

3 Personnel Supported

This research program was conducted by a multidisciplinary team from across the United States and Europe as listed below:

3.1 Principal Investigators

Gerald S. Frankel (Lead PI), Professor of Materials Science and Engineering and Director of the Fontana Corrosion Center, The Ohio State University, 2041 College Rd., Columbus, OH 43210, Tel: (614) 688-4128, Fax (614) 292-9857, email: frankel.10@osu.edu.

Clive R. Clayton, Professor of Materials Science and Engineering, State Univ. of New York at Stony Brook, Stony Brook, NY 11794-2275, Tel: (516) 632-9272 Fax: 516-632-8502, email: CCLAYTON@ccmail.sunysb.edu.

Richard D. Granata, Professor of Ocean Engineering, Florida Atlantic University, SeaTech, 101 North Beach Road, Dania Beach, FL 33004, Tel: (954) 924-7237, Fax: (954) 924-7007, email: rgranata@seatech.fau.edu. (Note that R. Granata moved to FAU from Lehigh University on 1/1/99.)

Hugh S. Isaacs, Metallurgist, Brookhaven National Laboratory, and Adjunct Professor at SUNY at Stony Brook, Brookhaven National Labs, Cornell Ave, Upton, NY 11973, Tel: (516) 344-4516, Fax: (516) 344-4071, email: isaacs@bnl.gov.

Martin W. Kendig, Senior Scientist and Member of the Technical Staff, Surface and Electrochemical Processes Department, Rockwell Science Center, 1049 Camino Dos Rios, Thousand Oaks, CA 91360, Tel: 805-373-4241, Fax: 805-373-4383, email: mwkendig@scimail.risc.rockwell.com.

Richard L. McCreery, Professor of Chemistry, The Ohio State University, 1118 Newman&Wolfram, 100 W 18th Ave., Columbus, OH 43210, Tel: (614)-292-2021, Fax: 614-292-1685, email: rmccreer@chemistry.ohio-state.edu.

Susan Smialowska, Professor Emeritus of Materials Science and Engineering and Director Emeritus of the Fontana Corrosion Center, The Ohio State University, 2041 College Rd., Columbus, OH 43210, Tel: (614) 292-0290, Fax (614) 292-9857, email: smialowska.1@osu.edu.

Martin Stratmann, Professor, Max-Planck-Institut fuer Eisenforschung, PO Box 140 444, D-40074 Duesseldorf, Germany, Tel: 011,-49-211-6792-466, Fax: 49 - 211 - 6792 - 440, email: stratmann@mpie.de. (Note that M. Stratmann moved to MPI from The University of Erlangen on 1/1/00.)

3.2 Other Personnel

Following is a list of undergraduates, graduate students, post-doctoral researchers, staff scientists, and other faculty who received support from this program or contributed to the technical accomplishments:

The Ohio State University

Dr. Patrick Schmutz, postdoc

Dr. Valerie Guillaumin, postdoc

Dr. Eiji Akiyama, postdoc

Dr. Patrick Leblanc, postdoc

Younghoon Baek, M.S. to be granted in January, 2002.

Xiaodong Liu, Ph.D. expected in 2003.

Donghui Lu, Ph.D. 2000, "The Influence of Inhibitor Ions on Localized Corrosion of Al and Al Alloys."

Derik Devecchio

Junye Zhu, MS non-thesis 1998.

Jun Zhao, Ph.D. 1997, "Surface Raman Spectroscopy: Instrumentation and Application in Surface and Corrosion Sciences".

Jeremy Ramsey, Ph.D. 2001, "The Corrosion Inhibition Mechanism of Chromium(VI): Probing the Interaction of Chromium(VI) with Aluminum Alloy Surfaces".

Lin Xia, Ph.D. 2000. Thesis title: "Formation and Function of Chromate Conversion Coating on Aircraft Aluminum Alloy Proved by Vibrational Spectroscopy".

William McGovern, M. S. 1999, "Chromium Deposition on Copper Containing Aluminum Alloys Studied via Raman, Profilometry Auger and Electrochemical Methods".

William Clark, Ph.D. expected in 2002.

Belinda Hurley, Ph.D. expected in 2004.

Takashi Itoh, postdoc

Brookhaven National Lab

Dr. Antonio Aldykiewicz, Jr., postdoc

Dr. Kotaro Sasaki, postdoc

Dr. Carol Jeffcoate, postdoc

Dr. Maria Oliveira, visiting scientist

Hochun Lee, postdoc

Feng Xu, M.S. Thesis, State University of New York at Stony Brook, 1999, "Studies of the Anodic and Cathodic Processes on Aluminum and Aluminum Alloy AA 2024-T3".

Rockwell Science Center

Dr. James Waldrop

Samuel Jeanjaquet

Melitta Hon

Dr. Robert Addison

Eric Cheng – Rockwell Youth Motivation Program Student

David Powers – Rockwell Youth Motivation Program Student

State University of New York at Stony Brook

Prof. G. P. Halada

S. Assefa, B.E., 1998

K. Bendyk, B.E., 1998

Sanjay V. Kagwade, Ph.D. 1998, "Surface Analytical and Electrochemical Studies of Aircraft Alloy Pretreatments and their Influence on Corrosion."

Jeffrey R. Kearns, Ph.D. 1999, "A Model of the Interfacial Processes Inhibiting the Environmental Degradation of Al-Cu Alloys."

Devicharan Chidambaram, PhD expected 2002

Marvin J. Vasquez, PhD expected 2002

Lehigh University / Florida Atlantic University

Dr. Mahmoud Madani, postdoc

Dr. Roy Miron, postdoc

Po-Nien. Chen, MS Thesis, Lehigh Univ., 1999, "The Effect of Chromate on Adhesion between Epoxy Coating and Al Substrate."

Yann Sigonney

Ronald Simmons, MS Thesis, Florida Atlantic University, 2001, "Mechanistic Study of Chromate Adhesion Enhancement on Aluminum 2024-T3 Alloy."

Kristina Mann

University of Erlangen / Max Planck Institute

Wolfgang Schmidt, Dipl. Eng., Univ. Erlangen, "The mechanism of filiform corrosion on polymer coated metals."

Jana Vander Kloet

Dr. Achim Walter Hassel

Christian Pittet, Diploma Thesis, 1997, Ecole Polytechnique, Lausanne, work performed at University of Erlangen, "Influence of Intermetallic Particles on the Corrosion of Chromated and Polymer Coated Aluminum Alloys."

4 Executive Summary

A variety of efforts by the MURI team generated many results that permit useful conclusions to be drawn about the protection of aluminum aircraft alloys by chromate-containing coatings. Many of the details are provided in the next section, which has summaries from each research group in the MURI team, and more details are given in the papers that have published over the past 5 years (listed in Chapter 6 of this report).

In this section, an attempt will be made to summarize the key findings related to chromate inhibition of Al alloy corrosion. The title of the MURI reflects the fact that much of the work also focused on the mechanism of Al alloy corrosion, and the knowledge generated from this work was critical for understanding the chromate inhibition mechanism. However, the main focus of the program was on chromate inhibition. Findings in Al alloy corrosion that are separate from chromate inhibition will not be addressed in this executive summary; interested readers are directed to the next section for these details. Furthermore, a book will be written within a year to summarize and synthesize the findings of this MURI and other recent work. This book will provide a detailed description of the recent developments in the areas of Al alloy corrosion, the inhibition provided by chromate in solution, the formation of CCC's and chromate release, and the effects of chromate in paints. For now, an executive summary of only the findings related to chromate inhibition mechanism will be provided.

In summary, the work of this MURI has shown that there are several reasons why chromate is an extremely effective corrosion inhibitor for Al alloys:

1. Chromate can be stored in conversion coatings and as a pigment in paints.
2. CCC formation involves several sequential steps, including etching of aluminum oxide by fluoride, reduction of Cr^{VI} to Cr^{III} mediated by $\text{Fe}(\text{CN})_6^{-3/4}$, polymerization of $\text{Cr}^{\text{III}}_x(\text{OH})_y$ and CrO_4^{-2} adsorption onto the $\text{Cr}^{\text{III}}_x(\text{OH})_y$ backbone. The resulting CCC is a $\text{Cr}^{\text{III}}\text{-Cr}^{\text{VI}}$ mixed oxide with an approximately 3:1 $\text{Cr}^{\text{III}}:\text{Cr}^{\text{VI}}$ molar ratio, containing low levels of $\text{Fe}(\text{CN})_6^{-3}$ and its degradation products. The distribution of Cr on the AA2024-T3 surface is uneven, with lower Cr levels on Cu-rich intermetallic particles.
3. Chromate is released from these CCC's and paint, particularly when they are scratched. The released chromate is in equilibrium with the chromate in the coatings, and higher pH favors Cr^{VI} release. Cathodic sites, which raise the local pH, may favor Cr^{VI} release. The concentration of Cr^{VI} in equilibrium with a CCC or SrCrO_4 pigment is approximately 10^{-4} to 10^{-3} M.
4. Chromate is mobile in solution and migrates to exposed areas on the Al alloy surface.

5. Chromate adsorbs on active corrosion sites of the surface and is reduced to form a monolayer of a Cr^{III} species. This monolayer inhibits further reduction of Cr^{VI} , but may adsorb a second layer of Cr^{VI} to form mixed oxide, depending on the pH.
6. This layer is effective at reducing the activity of both cathodic sites (Cu-rich IMC particles) and anodic sites in the matrix or at S phase particles. Inhibition in either or both cases is effected by blocking active sites, such as sites for O_2 adsorption, and reducing the tunneling rate of electrons through the inhibiting chromate film. Anodic inhibition involves reduction of localized corrosion initiation; localized corrosion growth is not inhibited by chromate, perhaps because chromate ions are fully protonated into an uncharged and inactive species in the low pH solutions that form in pits.
7. Adsorbed Cr^{VI} (unreduced) lowers the zeta potential and the pH of zero charge of Al oxide surfaces, which should inhibit chloride adsorption, consistent with the dipolar model for protective passive films.
8. SrCrO_4 pigments enhance the protective properties of even moderately good barrier coatings in the absence of obvious physical defects. They also improve adhesion of polymer coatings on AA2024-T3 surfaces, as do CCC's of a typical coating weight.
9. The combined properties of storage, release, migration, and irreversible reduction provided by chromate coatings underlie their outstanding corrosion protection. Of special note is the action of Cr^{VI} as a "suicidal inhibitor" in which reduction to Cr^{III} locks in the inhibiting film by converting mobile Cr^{VI} to insoluble and substitution inert Cr^{III} .

It is reasonable to expect that replication of these characteristics of chromate using another inhibitor species or combination of inhibitors is necessary to successfully replace chromate as a critical component for Al alloy corrosion inhibition.

5 Accomplishments

This section will summarize the technical accomplishments of this MURI program in more detail than the last section. For even more detail than is provided here, interested readers are directed to the numerous publications in the literature that have come from this work. The accomplishments are provided in separate sections from each PI.

5.1 Technical Summary of the McCreery Group at OSU

Three main issues were considered during the MURI project:

1. Formation and structure of chromate conversion coating (CCC).
2. Storage and release of Cr^{VI} in CCC, including the role of Cr^{VI} as active inhibitor.
3. The mechanism of corrosion inhibition on AA2024-T3 by Cr^{VI} .

The results are summarized below, with sections divided as indicated above and references to the list of publications at the end of this section. The formation of a CCC was shown to involve Cr^{VI} reduction to Cr^{III} , followed by formation of an insoluble $\text{Cr}^{\text{III}}\text{-Cr}^{\text{VI}}$ oxide (section 4.1.1)[1-3]. This mixed oxide has the important property of reversible binding of Cr^{VI} , so that Cr^{VI} is incorporated into the CCC film at about 1/3 the molar concentration of Cr^{III} . The formation of the CCC is catalyzed by redox mediation by ferricyanide [2], and is not homogeneous over the AA2024-T3 alloy [3]. We demonstrated that the $\text{Cr}^{\text{III}}\text{-Cr}^{\text{VI}}$ mixed oxide can release Cr^{VI} into dilute aqueous solution, with an equilibrium that is similar to a Langmuir adsorption isotherm (section 4.1.2)[4-6]. The "released" Cr^{VI} is capable of migrating to an unprotected alloy region, where it provides corrosion protection [6, 7]. The storage, release, and migration of Cr^{VI} is responsible for the critically important "self-healing" action of chromate conversion coatings and pigments. Section 4.1.3 addresses the action of dilute Cr^{VI} on AA2024-T3 and related materials. We showed that Cr^{VI} adsorbs on AlO_x surfaces, to form both an $\text{Al}^{\text{III}}\text{-Cr}^{\text{VI}}$ mixed oxide [7-9] and $\text{Cr}^{\text{III}}\text{-Cr}^{\text{VI}}$ mixed oxide [4]. In fact, Cr^{VI} forms an approximate monolayer of Cr^{III} on copper, platinum, or carbon surfaces [10, 11]. This monolayer inhibits anodic reactions on corroding alloys, but has a profound effect on oxygen reduction kinetics [10]. Inhibition of corrosion by Cr^{VI} is "locked in" by reduction to Cr^{III} , but this happens only at the monolayer level. The combination of storage, release, migration and irreversible inhibition is critical to the excellent properties of Cr^{VI} for corrosion protection.

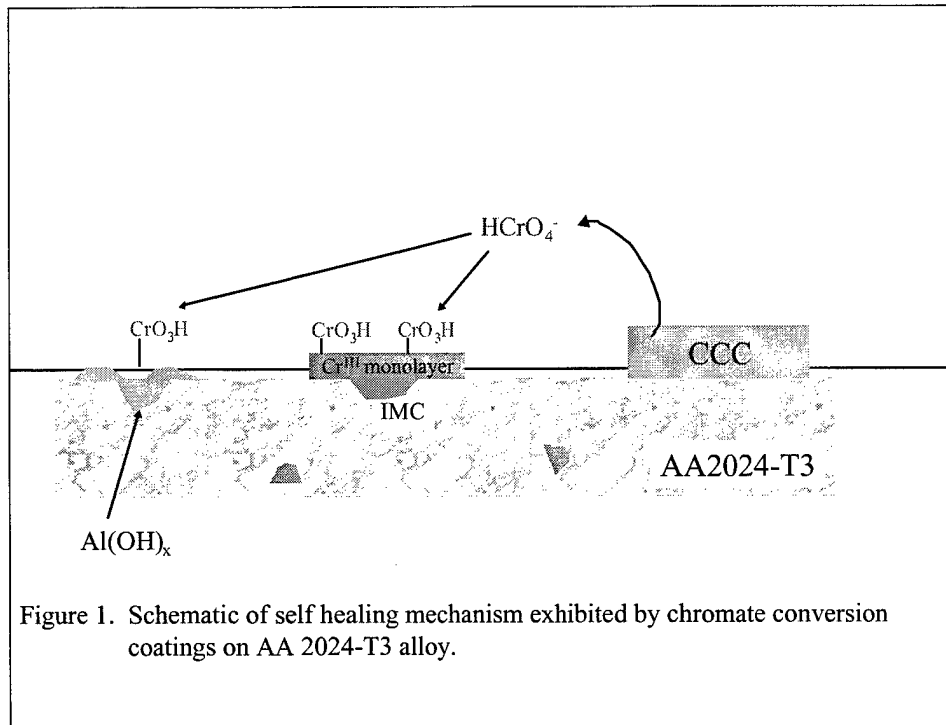

Figure 1. Schematic of self healing mechanism exhibited by chromate conversion coatings on AA 2024-T3 alloy.

5.1.1 Structure and formation of CCC films.

Elemental analysis and vibrational spectroscopy were used to probe the chemical structure of the CCC film. Synthetic oxides containing Cr^{III}, Cr^{VI}, and Al^{III} were synthesized to attempt to reproduce the structure of a CCC prepared on AA2024-T3. A Cr^{III}/Cr^{VI} mixed oxide was found to have spectroscopic and physical properties quite similar to a CCC formed on the alloy [12]. The CCC formation process is summarized in Figure 2, and involves simultaneous polymerization of Cr^{III} hydroxide and adsorption of Cr^{VI}. The CCC and the chromium III/VI mixed oxide had the following properties:

1. Negligible aluminum content.
2. 3:1 Cr^{III}:Cr^{VI} molar ratio.
3. Raman band at 858 cm⁻¹ that is pH and temperature independent.
4. Solubility at pH <2 and >9.
5. IR bands at 960, 919, 817 and 1621 cm⁻¹.
6. The ability to release soluble Cr^{VI} species and protect initially untreated AA2024-T3.

A structure proposed for the CCC and mixed oxide involving a covalent Cr^{III}-O-Cr^{VI} bond is shown in Figure 3. The structure is consistent with the vibrational spectra and D₂O and H₂¹⁸O isotope effects [1] as well as EXAFS and XPS reports in the literature. We propose that the Cr^{III}/Cr^{VI} mixed oxide binds and releases Cr^{VI} according to the mechanism of Figure 3.

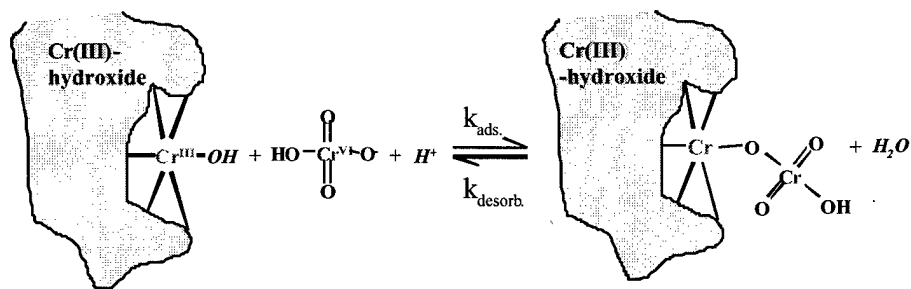
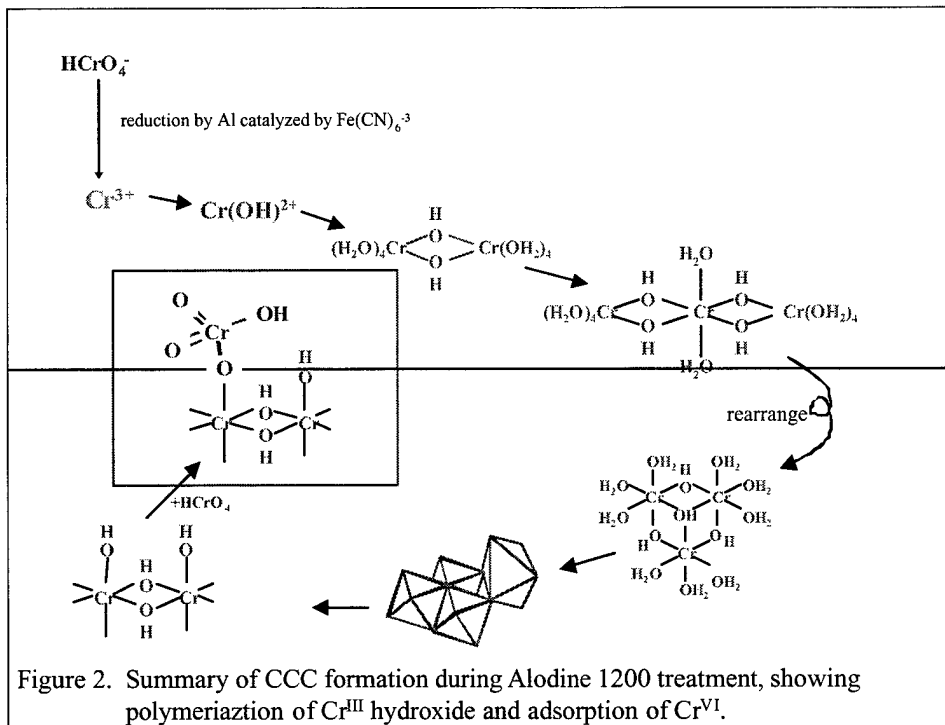

The chemistry of the mixed oxide is important to corrosion protection, since it can reversibly bind Cr^{VI} and can support “self healing”, as summarized below. We conclude that the Cr^{III}/Cr^{VI} mixed oxide is a major component of the CCC on AA2024-T3.

Ferricyanide is an “accelerator” in “Alodine” coating baths, but its role and acceleration mechanism were not previously understood. Raman and FTIR spectroscopy were used to determine the fate of $\text{Fe}(\text{CN})_6^{-3}$ in the CCC, and to examine its chemistry during CCC formation [1, 2] with the following conclusions:

1. Ferricyanide is incorporated in the CCC as physisorbed $\text{Fe}(\text{CN})_6^{-3}$ and as a Fe-CN-Fe polymer known as Berlin Green.
2. Ferricyanide rapidly oxidizes Al in AA-2024.
3. Ferrocyanide rapidly reduces $\text{Cr}_2\text{O}_7^{-2}$ to Cr^{III} .
4. Acceleration depends on a redox mediation mechanism, in which the slow reduction of $\text{Cr}_2\text{O}_7^{-2}$ to Cr^{III} is catalyzed by ferri/ferrocyanide as a consequence of points 2 and 3 above.
5. Several redox systems beside $\text{Fe}(\text{CN})_6^{-3/4}$ can act as mediators, including $\text{Fe}^{+3/+2}$ and $\text{IrCl}_6^{-3/-2}$. These mediators lead to effective CCC's similar to those produced from Alodine.
6. There is no evidence that ferricyanide is involved directly in the anticorrosion properties of the CCC, although that possibility cannot be completely ruled out.

We examined CCC formation on a composite of 5 phases of Al, Cu, and Mg and on AA2024-T3 [3, 13]. The copper rich phases show significantly thinner CCC films than adjacent Al-rich phases. Similar effects are apparent on AA2024, with thinner CCC films observed on Cu or Fe inclusions and intermetallic particles. The observation of adsorbed CN^- on Cu phases implies that ferricyanide decomposition on Cu may inhibit redox mediation, resulting in a thinner CCC on Cu phases.

5.1.2 Release of Cr^{VI} from CCC to effect “self healing”.

CCC treated and bare AA2024-T3 samples were placed face to face in an “artificial scratch” cell (figure 4) containing 0.1 M NaCl to determine if corrosion protection of the untreated alloy results from its proximity to the CCC sample [6]. Raman spectroscopy was used to monitor the release of chromate species from the CCC and the formation of $\text{Cr}^{\text{III}}/\text{Cr}^{\text{VI}}$ species on initially untreated alloy. Micrographs show that an initially untreated sample is protected from corrosion by migration from the CCC, while the control sample is seriously damaged. The polarization resistance of the remotely protected sample is comparable to that of a CCC on AA2024-T3. The split cell shows clearly that a CCC can protect a nearby exposed alloy surface, but it does not reveal the identity of the migrating species, nor the equilibria involved. We examined both Cr^{VI} speciation and the nature of the “release” equilibrium using UV-Vis and vibrational spectroscopy of the solution near a CCC.

Both old and recent literature on the speciation of Cr^{VI} in solution was examined, and new data from Raman spectroscopy were added to what has become a controversial area. The Cr-O-Cr linkage is observable with Raman, providing a definitive probe of the presence of dinuclear chromate species. By monitoring the Raman spectrum at different pH and Cr^{VI} concentration, it was possible to demonstrate that bichromate, HCrO_4^- must exist at low $[\text{Cr}^{\text{VI}}]$ and in the pH

range 2-6[5]. Above pH 6, only CrO_4^{2-} exists in solution, while in the range of 2-6, both $\text{Cr}_2\text{O}_7^{2-}$ and HCrO_4^- are present. At the low concentrations expected during release of Cr^{VI} from a CCC, HCrO_4^- is the predominant species. The main point relevant to corrosion inhibition by dilute Cr^{VI} is that below pH 6 Cr^{VI} is primarily HCrO_4^- , and above pH, it is CrO_4^{2-} . $\text{Cr}_2\text{O}_7^{2-}$ is a minor species for total Cr^{VI} levels below 10^{-3} M.

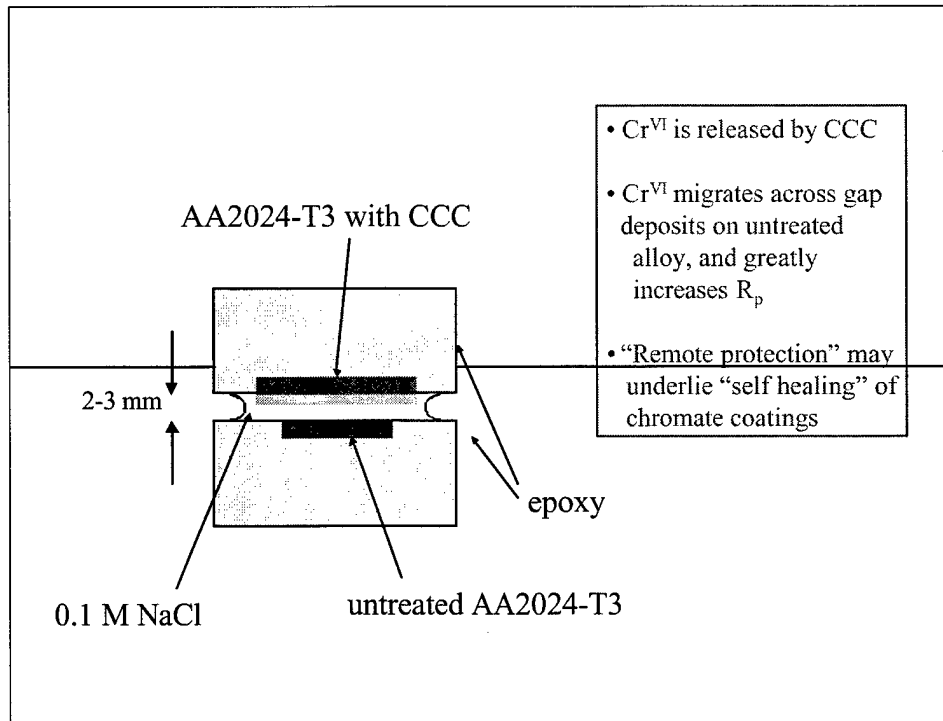

Figure 4. Artificial scratch cell used to demonstrate remote protection of bare AA2024-T3 by a nearby CCC.[6]

By observing the solution composition above a CCC in salt solution, we established that Cr^{VI} in solution is in equilibrium with Cr^{VI} in the CCC [4]. This equilibrium was examined by spectroscopically monitoring the solution concentration of Cr^{VI} above a CCC. Plots of $[\text{Cr}^{\text{VI}}]$ vs. time for various area to volume ratios showed “saturation” in which the $[\text{Cr}^{\text{VI}}]$ in solution reached a constant value upon release from a CCC. In addition, solution Cr^{VI} adsorbed to Cr^{III} hydroxide, to a level that depended on the area/volume ratio. These equilibrium Cr^{VI} concentrations are consistent with a Langmuir adsorption mechanism, involving formation of a $\text{Cr}^{\text{III}}\text{-O-Cr}^{\text{VI}}$ bond. The release of Cr^{VI} into solution is pH dependent, with higher pH shifting the equilibrium toward desorption. Under the low pH and relatively high $[\text{Cr}^{\text{VI}}]$ during Alodine treatment, adsorption of Cr^{VI} is favored. At higher pH and low Cr^{VI} , such as might occur in the field, desorption is favored. The adsorption/desorption is reversible with repeated pH excursions. This observation may explain why Cr^{VI} **adsorbs** during Alodine treatment, but **desorbs** and migrates in the field, in order to bring about ‘self healing’. In addition, the basic conditions near cathodic sites promote Cr^{VI} release and self healing.

Overall, the observations are consistent with the Langmuirian equilibrium between Cr^{VI} and Cr^{III} shown in figure 3. The kinetics of Cr^{VI} release from the CCC were studied in conjunction with the Frankel group, and are reported in another section of this report. The main conclusion of the efforts on Cr^{VI} storage and release are:

1. Cr^{VI} is released by the CCC, mainly as HCrO_4^- or CrO_4^{2-} , depending on pH.
2. Chromium is deposited on initially untreated alloy or defects, and is partially reduced to Cr^{III} .
3. The initially untreated alloy is protected from corrosion, as judged by appearance, polarization resistance, and polarization curves.
4. The rate of release of Cr^{VI} from the CCC depends on aging time of the original coating, with lower release rates for longer aging, and faster release at high pH.

5.1.3 In-situ Raman Microscopy of Chromate Effects on Aluminum Alloy

Now that we know that self healing by CCC films results from release of Cr^{VI} , the major question remains of how dilute Cr^{VI} inhibits corrosion. The interaction of dilute chromate with corroding alloy is responsible for passivation and protection. As a first step in establishing the mechanism of corrosion inhibition, we used spatially resolved Raman spectroscopy to observe chromate interactions with pits in AA2024-T3 immersed in salt water[8]. The approach permitted localized monitoring of chromate in and near pits, and Raman spectra revealed the composition of the corrosion products.

Our working hypothesis for the protection of aluminum alloys by a CCC is based on migration of soluble chromate from the CCC to an actively corroding site, possibly followed by reduction to a Cr^{III} oxide and formation of the $\text{Cr}^{\text{III}}/\text{Cr}^{\text{VI}}$ mixed oxide. To further explore this hypothesis, we have used in-situ Raman spectroscopy to monitor Cr^{VI} species in and near an active pit in AA2024-T3 immersed in 0.1 M NaCl. The spatial resolution of Raman was used both to localize the Raman measurement to the pit interior and to obtain Raman images of the Cr^{VI} species after interaction with the pit. After exposure to dilute Cr^{VI} , the Raman spectrum inside the pit exhibits a band at 850 cm^{-1} , whose appearance coincides with cessation of H_2 evolution. This band is not identical to the CCC Raman band, although they are quite similar. Dynamic Raman monitoring of alloy pits revealed the following:

1. The Raman bands for chromate species formed in pits differs slightly from that in a CCC, but the difference is significant. Mild heat treatment of the corrosion product causes changes in the Raman spectrum which differ greatly from those observed in a CCC.
2. The pH inside the pit appears to be higher than expected. Chromate reduction to Cr^{III} requires 8 H^+ , and may partially neutralize protons generated by pit growth.
3. The migration of dichromate into the pit **precedes** formation of mixed oxide. Presumably a certain amount of dichromate is reduced to Cr^{III} by the active aluminum surface before mixed oxide is formed.
4. The growth of the pit, judged both visually and from H_2 evolution, stops after entry of Cr^{VI} into the pit and formation of the 850 cm^{-1} band.

- The spectra of the product of the chromate interaction with an initially active pit corresponds to spectra of synthetic $\text{Al}(\text{OH})_3$ /chromate compounds, and to spectra of anodized alumina treated with chromate. These structures appear to involve covalent and/or electrostatic binding between Al^{III} hydroxide and Cr^{VI} species.

Comparison of dilute Cr^{VI} interactions with pits in AA-2024 to the chemistry of CCC formation in Alodine reveal some important differences. The low pH, high $[\text{F}^-]$, $\text{Fe}(\text{CN})_6^{3-}$ and relatively high $[\text{Cr}^{\text{VI}}]$ in Alodine favors formation of the $\text{Cr}^{\text{III}}/\text{Cr}^{\text{VI}}$ mixed oxide by dissolving Al oxides and creating a high Cr^{+3} concentration. In the pit, however, the absence of accelerator and fluoride puts Cr^{VI} in contact with $\text{Al}(\text{OH})_x$, thus favoring formation of the $\text{Al}^{\text{III}}/\text{Cr}^{\text{VI}}$ mixed oxide[8, 9].

Now that we know what compounds and structures form in the CCC and 2024 corrosion pit, how do they inhibit corrosion? The effects of Cr^{VI} on cathodic and anodic reactions were examined with an unusual split cell which permitted isolation of cathodic and anodic regions[10, 11]. Several experiments using pure Cu and Al electrodes were performed initially, to characterize the cell and determine chromate effects, with an example shown in Figure 5. Strong inhibition of oxygen reduction was observed when dilute chromate

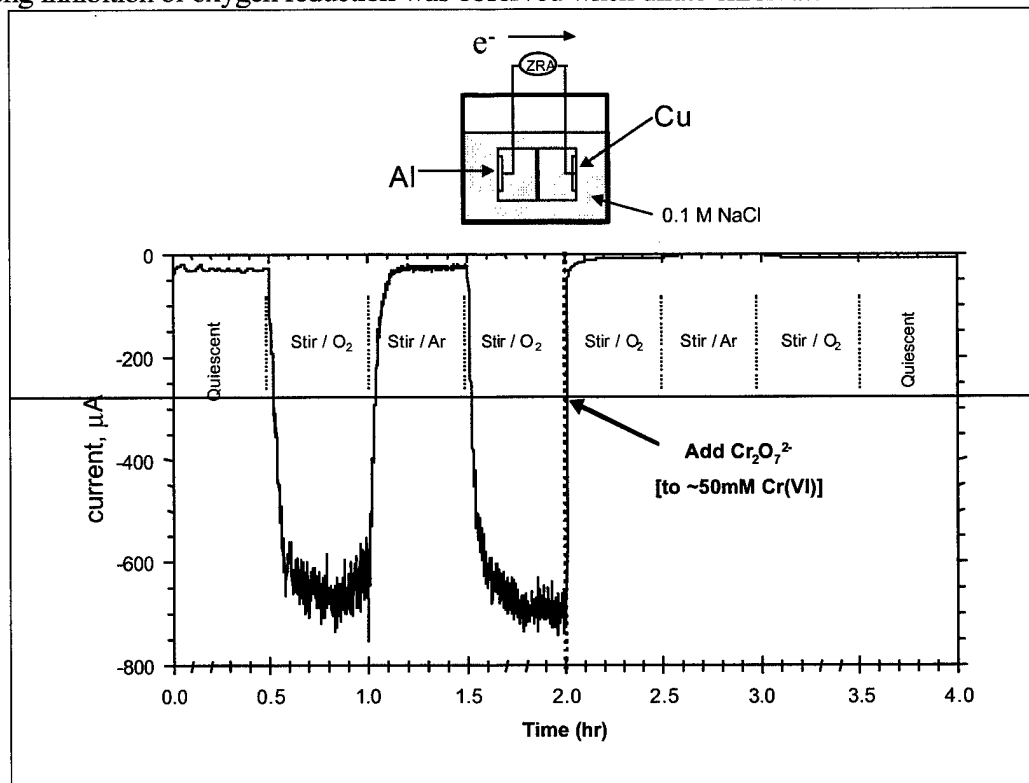

Figure 5. Galvanic current in an Al/Cu cell with variation in dissolved gas concentration. O_2 promotes a galvanic current from Al to Cu, but this current is severely inhibited by Cr^{VI} injection.

was added to a cell containing a Cu cathode, while no effect was observed when chromate was added to a pure Al anode. With 2024, both cathodic and anodic inhibition by chromate was observed. Two manuscripts are under consideration by The Journal of the Electrochemical Society on the conclusions from the split cell approach. These observations were combined

with many others from the MURI group to formulate a hypothesis that the primary mechanism of corrosion protection by chromate is inhibition of oxygen reduction on Cu sites, through formation of chemisorbed Cr^{III} oxide, possibly followed by a second layer of adsorbed Cr^{VI} . We showed that the reduction of Cr^{VI} is spontaneous on Cu, Pt, and glassy carbon, and stops at approximately one monolayer due to inhibition of electron transfer by the Cr^{III} layer. This monolayer (and possibly the additional Cr^{III} layer) inhibits O_2 reduction both by blocking catalytic sites and by inhibiting outer sphere electron transfer[10]. Figure 6 shows a schematic of Cr^{III} monolayer formation and Cr^{VI} adsorption.

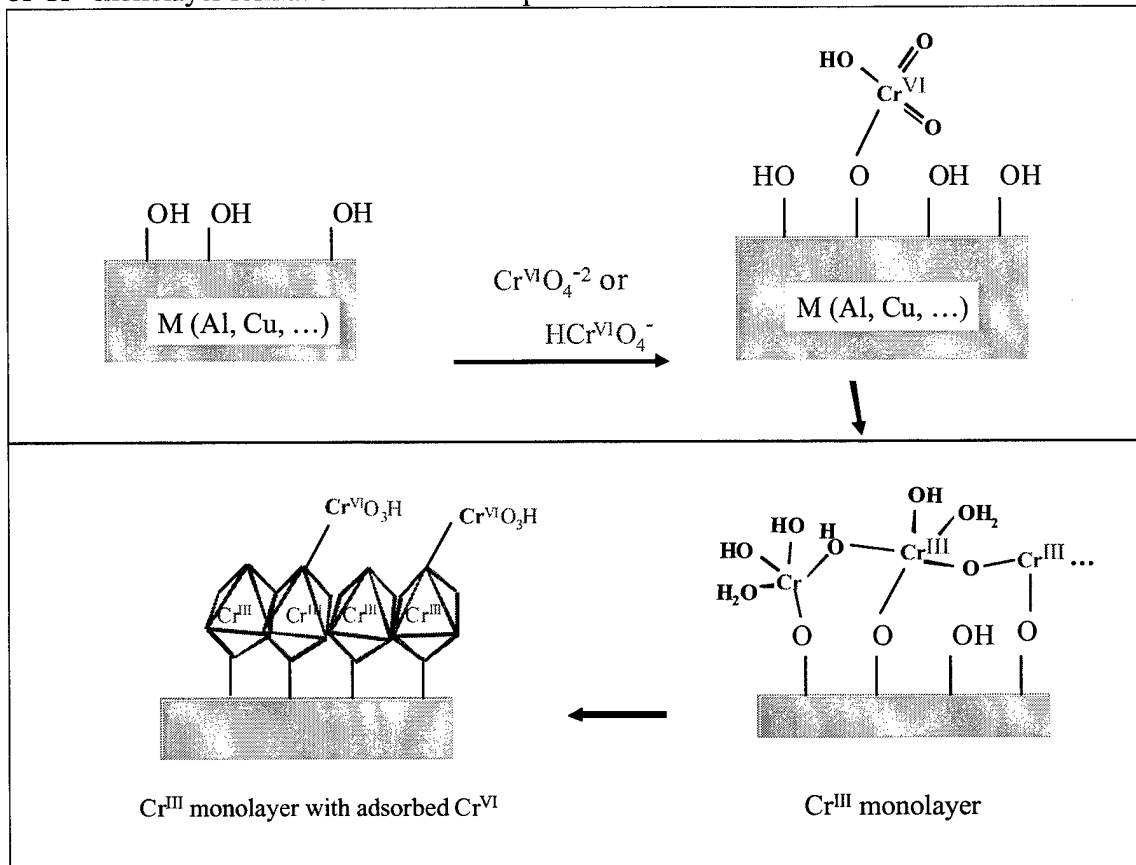

Figure 6. Likely mechanism for adsorption and reduction of Cr^{VI} to form a Cr^{III} monolayer, followed by adsorption of additional Cr^{VI} .

Overall, the important properties of Cr^{VI} coatings, in the form of a CCC or as a chromate containing primer, which determine its outstanding corrosion protection performance may be summarized as:

- Mobility - Chromate is stored in anticorrosion coatings and primers in a form which can migrate to damaged areas long after coating application. This property results in "self healing" of coating defects or damage over an extended period of time. The chemical identity and properties of the storage mechanism were determined.
- Adsorption - Mobile chromate interacts with corrosion sites selectively, both on aluminum pits and on copper-containing cathodic sites. This adsorption is

responsible for decreasing the loss of alloy from pitting and inhibiting the reactions of oxygen, which ultimately drive the corrosion process.

- Reduction - Once chromate is adsorbed to active sites, it may be reduced to Chromium III, which is substitution inert, nonmobile and permanent. This step forms a new Cr^{III} film and permanently inhibits corrosion activity at the formerly active site. At least one action of this Cr^{III} layer is O₂ reduction inhibition.

Overall, the MURI revealed that chromate acts like a "smart weapon" which stays dormant until needed, is released when damage occurs, then migrates to the damage site, adsorbs to it, and is transformed to a permanent, inhibiting form. The MURI identified the unusual combination of properties that underlies the effectiveness of chromium VI as a corrosion inhibitor. Since chromium VI is destined to be replaced by environmentally benign substitutes, the MURI conclusions about inhibition mechanism provide an excellent basis for designing chromate replacements.

5.1.3.1 References:

1. L. Xia, *Chemistry*, The Ohio State University, Columbus, (2000), p. 237.
2. L. Xia and R. L. McCreery, *J. Electrochem. Soc.*, **146**, 3696 (1999).
3. W. R. McGovern, P. Schmutz, R. G. Buchheit, and R. L. McCreery, *J. Electrochem. Soc.*, **147**, 4494 (2000).
4. L. Xia, E. Akiyama, G. Frankel, and R. L. McCreery, *J. Electrochem. Soc.*, **147**, 2556 (2000).
5. J. D. Ramsey, L. Xia, M. W. Kendig, and R. L. McCreery, *Corros. Sci.*, **43**, 1557 (2001).
6. J. Zhao, G. Frankel, and R. L. McCreery, *J. Electrochem. Soc.*, **145**, 2258 (1998).
7. J. Zhao, L. Xia, A. Sehgal, D. Lu, R. L. McCreery, and G. Frankel, *Surf. Coat. Technol.*, **140**, 51 (2001).
8. J. D. Ramsey and R. L. McCreery, *J. Electrochem. Soc.*, **146**, 4076 (1999).
9. J. D. Ramsey, *Chemistry*, The Ohio State University, Columbus, (2001), p. 277.
10. W. J. Clark and R. L. McCreery, submitted.
11. W. J. Clark, J. D. Ramsey, R. L. McCreery, and G. Frankel, submitted.
12. L. Xia and R. L. McCreery, *J. Electrochem. Soc.*, **145**, 3083 (1998).
13. W. R. McGovern, *Chemistry*, Ohio State University, (1999), p. 121.

5.2 Technical Summary of the Frankel Group at OSU

During the 5-year MURI program on chromates, the activities in the Frankel group at The Fontana Corrosion Center focused on Al alloy corrosion and the effects of chromates in solution. The results have been presented in several publications (see the list in the publications section of this report), and will be summarized in this section.

5.2.1 AFM-based studies

The AFM is a very useful tool for documenting and quantifying the extent of corrosion and for in situ observation of corroding surfaces. One of the major contributions of the Frankel group as part of the MURI program was to develop two new AFM-based approaches for the study of corroding Al alloys: Scanning Kelvin Probe Force Microscopy (SKPFM) [1,2] and AFM scratching [3,4,5].

SKPFM was a technique that had been developed for the study of semiconductor devices and not yet applied to corrosion prior to this MURI. It turns out that the technique is very well suited for corrosion studies because it is extremely sensitive to the distribution of charge across a surface. SKPFM is an easy, robust, and rapid means to map the practical nobility of a surface on a scale from tenths to tens of μm , which is the range that is relevant to Al alloy corrosion. It was determined that the measured signal is similar to a Volta potential, hence the use of the term Kelvin Probe in the name [1,2]. In contrast to a standard Kelvin probe, which nulls the capacitative current between a sample and a vibrating probe, the force between the sample and a conducting cantilever is nulled in the SKPFM. The Volta potential measured for a range of pure metals after removal from solution varies with the open circuit potential measured in the solution [1]. This is also true for a single metal exposed to different solutions in which it exhibits different open circuit potentials. The measured Volta potential for samples withdrawn from solution under potential control exhibit a slow decay associated with the oxide or double layer capacitance and a more permanent component associated with adsorbed species [2]. These studies validated the use of SKPFM, which must be applied ex situ, for relating the potential distribution across metal alloy surfaces to their corrosion behavior.

SKPFM was shown to be particularly useful for the study of Al alloys such as AA2024-T3, which exhibits high potential contrast associated with heterogeneities in the alloy on the order of tenths to tens of μm in size [1,3]. The intermetallic particles are clearly visible in the SKPFM potential maps, allowing a clear correlation of the localized corrosion behavior to the microstructure. Both AlCuFeMn and Al₂CuMg or S phase particles exhibit a high potential relative to the matrix for surfaces of samples polished without exposure to water, Figure 1. The high potential of the S phase particles results from the presence of a surface oxide layer. Removal of the oxide layer by scratching, sputter etching, or exposure to chloride solution results in a lowering or even reversal of the potential contrast [2,6]. On a polished surface, S phase particles corrode after a period of time during which their potential reaches that of the matrix [2]. After sputter etching of a polished surface, many S phase particles exhibit a lower

potential than the matrix, and these sites tend to corrode upon exposure to chloride solutions [6].



Figure 1. AFM image of intermetallic particles in AA2024-T3. Both images 80 x 80 μm , Left, topographical map with 100 nm z scale, right, Volta potential map with 1.5 V z scale [1].

More details of the interactions of various parts of the sample surface can be determined by opening up windows in a protective organic coating over select areas of the microstructure [6]. In order for corrosion to proceed, both active anodes and active cathodes must be exposed. AlCuFeMn particles are the most active cathodes on the as-polished surface; in 0.5 M NaCl they will drive corrosion either at S phase particles or in the matrix if these areas are simultaneously exposed. Localized corrosion will usually not proceed if the exposed region contains only matrix phase or matrix phase + S phase particles. Some large S phase particles will corrode by dealloying even without simultaneous exposure of AlCuFeMn particles, but they do not convert to active cathodes and drive corrosion in the matrix phase. Exposure of a large area of AA2024 to 0.5 M NaCl results in local attack within AlCuFeMn particles and possibly the conversion of S phase particles to active cathodes after dealloying.

In situ scratching of the alloy surface with an AFM tip is another method that was developed in this work [3,4,5]. Scratching and other depassivation techniques have been used for some time to study repassivation and the conditions for stabilization of localized corrosion. AFM scratching allows for controlled scratching at select areas of a microstructure using controlled tip/sample forces. AFM scratching of pure Al in 0.5 M NaCl results in accelerated dissolution in the scratched region, or trenching, if performed in stagnant solution in the small Nanoscope IIIa electrochemical cell. Sustained localized corrosion does not occur because of depletion of oxygen in the small cell. If fresh solution is continually pumped into the cell during AFM scratching, deep pitting attack results from the breakdown caused by the tip because dissolved oxygen is replenished by the pumping action. Scratching during potentiodynamic scanning and while the 0.5 M NaCl solution is pumped through the cell results in pitting at potentials slightly below the pitting potential for an unscratched electrode. AFM scratching of AA2024-T3, even in a stagnant 0.5 M NaCl solution, results in immediate attack at the S phase particles even with

the lightest scratching force because of destabilization of the somewhat protective oxide surface film on those particles.

These techniques, i.e. SKPFM and AFM scratching, were useful for illuminating various aspects of the effects of chromate on the corrosion process. AFM scratching of a pure Al sample upon immediate exposure to stagnant 0.5 M NaCl + 10^{-4} M $\text{Na}_2\text{Cr}_2\text{O}_7$ results in pitting similar to that found for the case of the pumped 0.1 M NaCl solution [3]. This example shows how chromate can act as a deleterious oxidizing agent under certain conditions. If the sample is allowed to be exposed to the 0.5 M NaCl + 10^{-4} M $\text{Na}_2\text{Cr}_2\text{O}_7$ solution for a period prior to scratching, the behavior is completely different. After a protective film is allowed to form, AFM scratching (with an SiO_2 tapping mode cantilever) cannot destabilize the surface so that neither a pit nor a trench forms. No attack is evident.

The addition of 10^{-4} M $\text{Na}_2\text{Cr}_2\text{O}_7$ to the 0.5 M NaCl solution suppresses corrosion of AA2024-T3. Rather than a merging of the Volta potentials measured by SKPFM to a similar value, as is observed during exposure to pure chloride solution, the contrast at the intermetallic particles persists [6], Figure 2. During AFM scratching in 0.5 M NaCl + 10^{-4} M $\text{Na}_2\text{Cr}_2\text{O}_7$, the breakdown of the S phase particles seen in pure chloride solutions is eliminated and pits form in the matrix phase instead. In solutions containing higher concentrations of dichromate, higher tip forces are required to cause breakdown. No corrosion was observed if a window containing cathodic area (AlCuFeMn particles) was pretreated in chromate solution and then simultaneously exposed to a pure chloride solution along with another un-pretreated area containing anodes (S phase and matrix). The same result was found if the anodic area was pretreated and the cathodic area was not. This shows that chromate can act as both cathodic and anodic inhibitor.

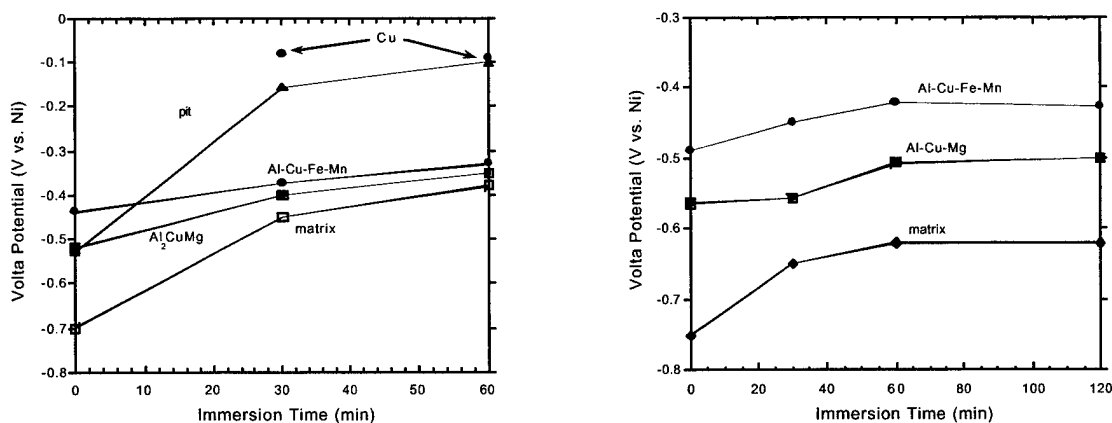

Figure 2: Volta potential change of matrix and intermetallic particles of AA2024-T3 in 0.5 M NaCl (left), 0.5 M NaCl + 10^{-4} M $\text{Na}_2\text{Cr}_2\text{O}_7$ (right) [6].

Since the behavior of S phase Mg is critical to the performance of AA2024, and Mg is a critical component of S phase, pure Mg was studied [7]. The rapid and massive attack of Mg in

chloride solution is changed by the presence of a small amount of dichromate. In 0.5 M NaCl + 10^{-4} M $\text{Na}_2\text{Cr}_2\text{O}_7$, strong localized attack in the form of filiform-like corrosion is observed at specific low index twin boundaries.

5.2.2 Artificial crevice studies

One of possible explanations for the effect of chromates on Al alloy corrosion is anodic inhibition, in the sense that chromates might greatly reduce the local dissolution kinetics of Al alloys in pits or crevices. The repassivation potential is the lowest potential at which the critical current density for pit growth can be maintained. Since pits or acidic crevices must maintain a minimum or critical current density in order to avoid repassivation, a decrease in the pit or crevice dissolution rate as a function of potential could inhibit localized corrosion by increasing the repassivation potential, which is the potential required to achieve the critical current density.

Artificial pit or "lead in pencil" electrodes have been used by researchers previously to study pit growth kinetics. The artificial pit electrode geometry forms a single pit in which the whole electrode area is active, generates a natural pit environment, and provides an ideal one-dimensional transport condition. The artificial crevice electrode is similar to the artificial pit electrode, except that a metal foil instead of a wire is used to create a recessed band instead of a recessed disk. Hydrogen bubbles can escape easier from this geometry, so artificial electrodes are useful for studying the localized corrosion kinetics of Al or Mg, in which copious hydrogen is evolved.

Dissolution kinetics for pits and crevices in aluminum and the effect of dichromate ions on the dissolution kinetics were investigated by using artificial crevice electrodes [8,9]. The aluminum artificial crevice electrodes were potentiostatically polarized over a range of potential in 0.1 M NaCl solution with and without dichromate ions. The anodic dissolution charge and cathodic charges for the hydrogen and dichromate reduction reactions were measured. The addition of dichromate ions does not suppress the active dissolution. This indicates that the mechanism of localized corrosion inhibition by dichromates is something other than anodic inhibition of Al dissolution in the pit or crevice environment. The relative amount of local cathodic reactions on Al increases by the addition of dichromate because of the dichromate reduction. The initial dissolution of aluminum in a crevice is ohmic-controlled. From the change in the dissolution current with time, the conductivity of the crevice and potential at the bottom of crevice are estimated. The conductivity and the bottom potential decrease with the ratio of cathodic charge of hydrogen evolution to anodic dissolution charge. The conductivity in the crevice and thus the dissolution current seem to be controlled by hydrogen evolution and only indirectly by dichromate concentration.

In a follow-on study, the effect of four anions on dissolution kinetics of Al and Mg in chloride-containing solution was investigated using the artificial crevice technique [9]. Polarization curves for Al and Mg artificial crevice electrodes were obtained by first dissolving the artificial crevice electrode to a fixed depth at a high potential and then scanning the potential downward to the repassivation potential. Potential components were obtained by fitting the polarization curve to

an equation describing activation overpotential and ohmic potential drops. Of chromate, dichromate, molybdate and nitrate, only nitrate inhibits the dissolution kinetics of Al artificial crevice electrodes, Figure 3. In contrast, all anions inhibit the dissolution kinetics of Mg artificial crevice electrodes. The results support the notion that the mechanism of localized corrosion inhibition of Al alloys by chromate must be something other than inhibition of anodic dissolution in an active pit or crevice.

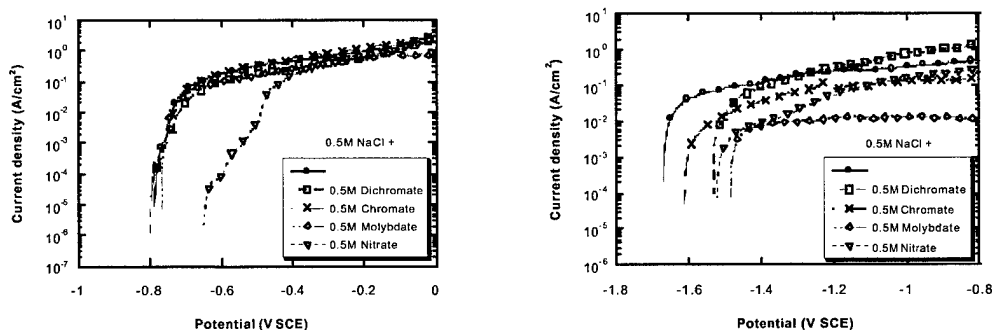

Figure 3. Effect of various inhibitor ions at a concentration of 0.5 M on dissolution kinetics in 0.5 M NaCl for artificial crevice electrodes of (a) Al, (b) Mg [9].

5.2.3 Electrochemical Quartz Crystal Microbalance (EQCM) studies

Characterization of electrochemical activity of intermetallic compounds and the Al matrix in AA2024 is critical for understanding corrosion behavior of this alloy. However, cathodic corrosion of Al and Al alloys makes it very difficult to determine the true cathodic kinetics using only electrochemical techniques. The electrochemical quartz crystal microbalance was used to directly measure the mass loss rate, and thus the anodic reaction rate, of thin film analogs in this alloy [10]. The thin films studied include pure Al, Al-4 Cu, which is an analog for the matrix phase, and Al₂Cu, which is an analog for θ phase and other high Cu cathodic intermetallic particles. The true cathodic reaction rate was calculated from the summation of the net and the anodic current density. For pure Al in unbuffered 0.1 M NaCl, the anodic current density is large relative to the net current density, so the true cathodic current density is considerably larger than the measured net current density. The anodic current density and the cathodic current density are weakly dependent on potential and the presence of dichromate in the solution, even though the net current density shows stronger dependencies. The cathodic current density was almost identical to the net current density for Al₂Cu or θ phase because the anodic dissolution rate was very small compared to the cathodic reaction rate.

The effect of chromate in solution was studied by adding 10^{-2} or 10^{-4} M Na₂Cr₂O₇ to 0.1 M NaCl, and adjusting the pH to 6.2 by adding NaOH. The addition of dichromate decreases the net current density and the true cathodic current density. The largest effect was found for θ phase, though the effect was not as large as is found for AA2024-T3.

5.2.4 Chromate release studies

The release of chromate ions from chromate conversion coatings (CCCs) on Al alloys was studied, and the effect of aging of CCCs on the chromate release kinetics was investigated. Chromate release from CCCs into aqueous solutions was monitored by measuring the change in the chromate concentration in solution using UV-vis spectroscopy [11]. Heat treatment of the CCC greatly reduces the chromate release rate. The chromate release rate also decreases with increasing aging time at room temperature. Work from the McCreery group in the MURI program showed that the steady state concentrations of Cr(VI) species in solutions contacting a CCC can be described by a Langmuirian adsorption/desorption equilibrium. In this work, a diffusion-control model for the release kinetics was proposed based on the notion that the CCC in an aqueous solution is a porous two phase structure consisting of a solid phase with adsorbed Cr(VI) species that is in local Langmuir-type equilibrium with an interpenetrating solution phase. This model results in a concentration gradient of soluble Cr(VI) in the solution phase of the CCC as chromate is released. The concentration and diffusion coefficient of soluble Cr(VI) in CCC can be estimated with this model. The estimated diffusion coefficient tends to decrease with aging time suggesting that the CCC is modified with aging time, Figure 4.

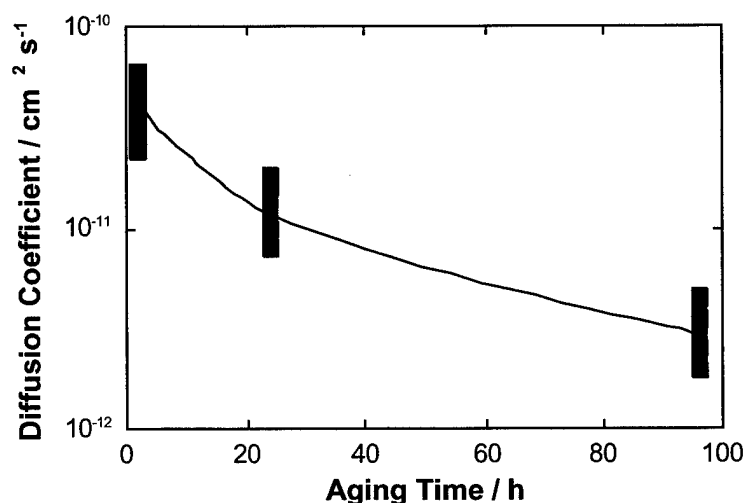

Fig. 4. Estimated diffusion coefficient of Cr(VI) species in the CCCs on AA1100 as a function of aging time at RT [11].

5.2.5 References

1. P. Schmutz and G. S. Frankel, "Characterization of AA 2024-T3 by Scanning Kelvin Probe Force Microscopy", *J. Electrochem. Soc.*, **145**, 2285 (1998).
2. V. Guillaumin, P. Schmutz, and G. S. Frankel, "Characterization of Corrosion Interfaces by the Scanning Kelvin Probe Force Microscopy Technique" *J. Electrochem. Soc.*, **148**, B163-173 (2001).

3. P. Schmutz and G. S. Frankel, "Corrosion Study of AA2024-T3 by Scanning Kelvin Probe Force Microscopy and *In Situ* AFM Scratching", *J. Electrochem. Soc.*, **145**, 2295 (1998).
4. P. Schmutz and G. S. Frankel, "Influence of Dichromate Ions on Corrosion of Pure Aluminum and AA2024-T3 in NaCl Solution Studied by AFM Scratching," *J. Electrochem. Soc.*, **146**, 4461 (1999).
5. D. Devecchio, P. Schmutz, and G. S. Frankel, "In situ AFM Scratching as an Analog to Metal CMP," *Electrochem. Solid-State Lett.*, **3** 90 (2000).
6. P. Leblanc and G. S. Frankel, "A Study of Corrosion and Pitting Initiation of AA2024-T3 Using Atomic Force Microscopy" accepted for publication in *J. Electrochem. Soc.*, 11/01.
7. P. Schmutz, V. Guillaumin, S. Lillard, J. Lillard and G. S. Frankel, "Influence of Dichromate Ions on Corrosion Processes on Pure Magnesium," in preparation.
8. E. Akiyama and G. S. Frankel, "The Influence of Dichromate Ions on Al Dissolution Kinetics in Artificial Crevice Electrode Cells," *J. Electrochem. Soc.*, **146**, 4095 (1999).
9. Q. Meng, T. Ramgopal and G. S. Frankel, "The Influence of Inhibitor Ions on Dissolution Kinetics of Al and Mg Using Artificial Crevice Technique," accepted for publication in *Electrochem. Solid-State Lett.*, 11/01.
10. Y. Baek and G. S. Frankel, "Electrochemical Quartz Crystal Microbalance Study of Corrosion of Phases in AA2024-T3," in *Corrosion and Corrosion Protection*, J. D. Sinclair, E. Kalman, M. W. Kendig, W. Plieth, and W. H. Smyrl, eds, PV 2001- 22, The ECS Proceedings Series, Pennington, NJ (2001).
11. E. Akiyama, A. J. Markworth, J. K. McCoy, G. S. Frankel, L. Xia, and R. L. McCreery, "Storage And Release Of Soluble Hexavalent Chromium From Chromate Conversion Coatings On Al Alloys; Kinetics Of Release," submitted to *J. Electrochem. Soc.*, 11/01.

5.3 Technical Summary of the Group at Rockwell Science Center

5.3.1 Background

The oxo-anionic compounds of hexavalent chromium (referred to in the technical literature as chromate or dichromates) have a seemingly unique capability for protecting light metals and alloys from corrosion. Unfortunately these compounds are both toxic and carcinogenic. Elimination of hexavalent chromium from the environment during the manufacturing of aircraft and aerospace vehicles requires a clear understanding of the mechanism by which hexavalent chromium protects aluminum and its alloys, particularly the difficult to protect Cu-rich 2000 series materials.

By hypothesis, chromate conversion coatings form from the reaction of hexavalent oxo-chromium (VI) anions with aluminum to generate a chromium(III) oxide film that retains releasable Cr(VI). The residual Cr(VI) can move from the coating in the presence of a corrosive environment to defects in the film where it provides subsequent inhibition. An activity of oxo-Cr(VI) anions in the environment has been hypothesized to inhibit corrosion primarily by limiting the oxygen reduction reaction occurring at cathodic sites on the alloy surface, but it also passivates anodically active phases. In addition, Cr(VI) adsorbs on aluminum oxide so as to stabilize the oxide in the presence of chloride.

While other members of the MURI team confirmed the active inhibiting behavior and structure of the releasable chromate in conversion coatings, and galvanic nature of intermetallic phases, Rockwell Scientific's effort focused on the following:

- Characterization of the nucleation of chromate conversion coatings on Al 2024-T3
- Characterization of the adsorption of hexavalent chromium on anodized aluminum oxide
- Implications of the speciation of oxo-Cr(VI) in aqueous environments
- Influence of hexavalent chromium on the oxidation and reduction kinetics at Cu-rich intermetallics
- Mechanism of inhibition of the oxygen reduction reaction (ORR) by Cr(VI) in neutral electrolytes.

5.3.2 Scientific Goals

The overall scientific goal of this program has been to elucidate the details of the mechanism by which hexavalent chromium inhibits corrosion of aluminum alloys, particularly the difficult to protect 2xxx series alloys. Rockwell Scientific's specific goal was to determine how the ionic species of oxo-Cr(VI) interact with intermetallic phases and aluminum oxide to achieve an overall corrosion inhibition.

5.3.3 Experimental Approaches

PEK Experiment

Previously reported work on hexavalent chromium-sealed anodized aluminum suggests that chromate does not actually 'seal' porous anodized aluminum in the sense that it plugs pores [1]. Rather, chromate seals with a reinforcement of the pore-wall [2] as compared to the completely-plugging hot-water sealing. One way that a small quantity of oxy-chromium (VI) anions improves corrosion resistance without plugging the pores is by changing the surface charge of the oxide so as to discourage adsorption and transport of chloride. Such a mechanism has been shown to occur for ferrous oxide films [3-4] and has been proposed for aluminum oxide covered surfaces [5-11].

Fortunately there exists a rather elegant method for interrogating the surface of the pore of anodized aluminum as to its surface charge. In the mid 1980's, Bernstein and White reported that when an ultrasonic wave passes through an anodic film immersed in an electrolyte it shears the double layer in the pores of the film so as to produce an alternating voltage [12]. An alternative approach for acoustically assessing the zeta potential of a porous medium entails applying a high frequency electrical signal while observing the acoustic response [13]. In the former Bernstein and White approach, the piezo-electrokinetic (PEK) response results from oscillation in the streaming potential produced within the porous aluminum oxide in response to an applied acoustic pulse. In principle, the magnitude of this signal relates to the magnitude and sign of the zeta potential, ζ , of the oxide and the phase depends on the sign of ζ . Note that ζ and the surface charge, σ , are related to each other through the following equation:

$$(1) \quad \sigma = D\zeta/(4\pi\gamma),$$

where σ = surface charge, γ = Debye length (constant with constant ionic strength and dielectric constant) and D = the diffusion coefficient for the ions of the double layer. According to the model developed in ref 12, the normalized piezo-kinetic response has the following form:

$$(52) \quad V_{out}/u(0) = \pi nR^2 \sigma \gamma / (2\omega^{1/2} \epsilon_{pore} \alpha^{1/2} \mu^{1/2})$$

where ϵ = dielectric constant of the fluid in the pore, α = the fluid's compressibility, ω = angular frequency of the acoustic signal, and R = the pore diameter.

Using a test cell similar to that described previously [12], the PEK response for sulfuric acid anodized high purity aluminum, exposed to electrolytes typically of constant ionic strength, has been determined as a function of pH and oxo-Cr(VI) anion concentration. The results for the chromate-containing solutions were compared to those for a nitrate-containing solution since the nitrate has been shown not to specifically adsorb on aluminum oxide surfaces [14].

AFM Analysis of the Nucleation of Chromate Conversion Coatings

Al 2024-T3 specimens were polished to a 0.01 μm finish in a non aqueous environment as described previously and exposed for short times in cold (5°C) Alodine 1200 chromating reagent so as to just initiate the chromate conversion coating process. The resulting specimens

were rinsed in distilled water and stored in a vacuum desiccator before examining using an atomic force microscope (AFM) [15].

EIS of Chromate Inhibited Intermetallics

Intermetallic specimens of theta phase CuAl_2 prepared as previously described were exposed to NaCl solution with and without 10 mM Cr(VI). An electroplater's mask was used to isolate single grains of the material for the electrochemical analysis. Alternatively, a microelectrochemical cell approach previously described by Sutter et al. [16] and implemented at Ohio State University was used to perform potentiodynamic polarization on individual δ -phase Cu,Mg aluminide grains.

Cyclic Voltammetry

Copper and gold rotating disk electrodes (RDEs) were used for evaluating the electrochemical reduction kinetics of oxygen and hexavalent chromium in near neutral (pH 6.1) solution.

Phase Transfer Catalyst

In order to establish the degree of ionization of oxo-chromium anions at low pH a phase transfer compound, Adogen 464, was used to form ion complexes with oxo-Cr(VI) anions. The ion complexes can dissolve in an organic phase (hexane). Extraction of chromate into hexane occurs when the Cr(VI) compound exists as an anion. Extraction of Cr(VI) was detected as a yellowing of the hexane phase. In this way the pH range (under acidic conditions) over which oxo-Cr(VI) anions exist could be established.

5.3.4 Summary of Results

5.3.4.1 *Ionic Interactions with Oxides*

The pH dependence of the PEK signals for the anodized Al 1100 is summarized in Figure 1. For some of the data points in Figure 1, a scaled waveform has been superimposed to illustrate the phase and, hence, justify the assignment of the sign to the signal. The PEK signal for the sample in the nitrate solution remains high and of the same phase over the accessible pH range (pH 4 - pH 11). Higher pHs were not evaluated since the oxide becomes unstable to rapid dissolution. The error bars for the variation of pH were determined from the pH measured before and after the experiment. The pH of the oxo-Cr(VI) buffer solutions was stable during an experiment. Despite efforts to buffer the nitrate solutions, rather extensive pH variation was observed. Hence the large error bars for the high pH, non-chromate nitrate solutions. The PEK signal changes phase, which indicates a change of sign at high pH. The pH where the sign changes is called the pH of zero charge (pzc).

Chromate significantly lowers the surface charge (zeta potential) within the porous anodized layer on sulfuric acid anodized aluminum for pH above 4. For very low pH, chromate does not lower the zeta potential as evidenced by no lowering of the PEK signal. This is a result of complete protonation of the chromate or dichromate anion. The pH of zero charge for the interior surface of the porous anodic film is above 10.5 in the non-complexing sodium nitrate.

This pzc exceeds that typically reported for alumina particles and reflects the properties specific to the pore interior. The presence of just 0.01 M oxo-Cr(VI) lowers the pzc of the pore interior to 8.2. Furthermore, the presence of dilute chromate substantially lowers the surface charge on the surface of aluminum oxide without being converted irreversibly to Cr(III) oxide. Hence, we conclude that hexavalent chromium provides corrosion inhibition to anodized aluminum without reductively converting to an inert Cr(III) oxide species. The oxo-Cr(VI) anions accomplish this by specific adsorption on the oxide surface so as to discourage the adsorption of chloride. The reader can find additional details of these results in the published literature [17].

5.3.4.2 Cr(VI) Speciation

Using data available in the literature, the relative concentrations of the different oxo-Cr(VI) anions can be calculated. The distribution depends on total Cr(VI) concentration and pH. The calculated distributions have been shown in collaboration with McCreery et al. to be consistent with spectroscopic observation [18]. An important result of this work has been the observation that, depending on total chromate concentration, for a sufficiently low pH, the chromate oxyanions are completely protonated and are not active. This can be seen from the relative extraction of yellow Cr(VI) into an organic phase from water by a long chain alkyl ammonium cation. If the pH of the aqueous phase is sufficiently low, no anions are present to be extracted by the organic cation (see Figure 2). Hence for a sufficiently active and acidic pit, Cr(VI) would not effectively inhibit anodic dissolution. This is consistent with observations by that Cr(VI) does not inhibit in very acidic anodically formed pits [19].

5.3.4.3 Nucleation of Chromate Conversion Coatings

The formation of a chromate conversion coating on a highly polished Al 2024-T3 specimen initiates on the more cathodic, blocky shaped FeMnCu aluminides as shown in Figure 3 [15]. Once nucleated, the film inhibits further reaction.

5.3.4.4 Inhibition of Oxygen Reduction

Inhibition of the cathodic oxygen reduction reaction (ORR) on a Cu cathode does not require formation of a three dimensional film, but rather results from a sub-mololayer electrosorption of a Cr(III) species. Furthermore, such an adsorbed film inhibits bulk conversion of Cr(VI) to Cr(III) as well as reduction of oxygen. The current vs voltage data presented in Figure 4 for a rotating Cu cathode illustrate these points [29]. In the absence of any inhibitors, a current plateau appears between -0.6 and -1.1 V SCE due to diffusion-limited oxygen reduction. In the presence of Cr(VI), the current between -0.6 and -0.8 V is dramatically decreased as a result of the inhibition of oxygen reduction. The current increases to a plateau more negative than -0.8 V as a result of chromate reduction. Note that -0.8 V represents an extremely large overvoltage for chromate reduction indicating that the process that inhibits oxygen reduction also inhibits chromate reduction. Ce(III) does not seem to provide the same degree of inhibition of the ORR as does the Cr(VI) oxo-anions. Clark and McCreery will publish similar conclusion based on their work on the reduction of Cr(VI) on glassy carbon electrodes [30]. Cyclic voltammetry (Figure 5) in the -0.4 to -0.6 volt range provides evidence that the adsorption process giving rise to this inhibition involves a reduction process, presumably that of Cr(VI) to

Cr(III). Ilevbare and Scully had previously demonstrated the effectiveness of Cr(VI) as an irreversible ORR inhibitor on a variety of cathodes [20-22].

5.3.4.5 *Inhibition of Anodic Reactions*

The sigma phase Cu,Mg aluminides are particularly reactive. Scully et al. demonstrated the formation of metallic Cu cathodes by the corrosion of this phase [23]. The Cu,Mg aluminide phase dealloys to produce a very active Cu-rich cathodic site for initiating adjacent pitting [24-25]. Alternatively these phases may anodically dissolve to form Cu clusters which disperse into the corrosive environment where, once disconnected from the base metal, corrode and redeposit as Cu cathodes [26]. Cr(VI) oxo-anions in dilute, slightly acidic chloride not only inhibits the high cathodic activity of the dealloyed phase, but also passivates these surfaces to produce a low passive current [27]. Electrochemical impedance analysis of the inhibition shows that a two dimensional passive film is formed by the chromate [28].

Cr(VI) has significant effects on the reaction kinetics of the dealloyed layer formed on the S phase. Figure 6 shows a potentiodynamic scan at 10 mV/s from -1.40 V to 0.00 V SCE for S phase in 10 mM NaCl with and without 5 mM Cr(VI). As can be seen, addition of chromate lowers the cathodic current density for the S phase between the open circuit potential and -1.20 V. Chromate appears to inhibit the oxygen reduction reaction. The chromate also shows anodic passivation (with a passive current density below 1 $\mu\text{A}/\text{cm}^2$ from open circuit up to a potential of -0.4 V where the anodic current rises). A breakdown potential, E_{br} , measured in chloride/chromate solutions is not very reproducible, but generally falls below the E_{br} measured in chromate-free solutions for which the intermetallic phase had already dealloyed to form a pseudo-passive porous Cu layer [27].

These results suggest that the oxo-Cr(VI) species at this pH of 4.3 effectively inhibits the dealloying of the intermetallic. As a result of both the lack of dealloying and the presence of an adsorbed chromate layer (either as Cr(VI) or Cr(III)), the rate of oxygen reduction in the open-circuit to -1.2 V region remains substantially lower than that observed on the dealloyed intermetallic in the absence of chromate. Furthermore, the intermetallic shows some actual passivity above open circuit with a current density limited to about 1 $\mu\text{A}/\text{cm}^2$. However, the surface passivated by chromate becomes active with polarization above a rather low E_{br} value compared to the polarization required for the dealloyed pseudo-passive, cathodically active surface [27].

5.3.5 Conclusions

The results show that hexavalent chromium behaves primarily as a good inhibitor of ORR at cathodic sites on high-strength Al alloys. The mechanism of ORR inhibition entails electroadsorption of a sub-monolayer of a Cr(III) surface compound that inhibits both ORR and further chromate reduction. Cr(VI) readily adsorbs as the unreduced anion on Al oxide to lower the zeta potential and the pH of zero charge of the oxide. As such, adsorption of the chromate discourages chloride adsorption and destabilization of the oxide. Chromate appears to inhibit the anodic dissolution of the very active intermetallic Cu,Mg aluminide phase. This

also limits the formation of sites for oxygen reduction. Speciation of the hexavalent chromium is important as the anionic form provides the active inhibition. At very low pH such as in active pits the chromate anion(s) can become completely protonated and rendered inactive.

5.3.6 References

1. F. Mansfeld and M. Kendig, *J. Electrochem. Soc.*, 135(4), 828 (1988).
2. J. P. Hoar and G. C. Wood, *Electrochim Acta*, 7, 333 (1962).
3. M. Sakashita and N. Sato, *Corros. Sci.*, 17, 473 (1977)
4. N. Sato, *Corrosion*, 45(5), 354 (1989).
5. P. M. Natishan, E. McCafferty and G. K. Hubler, *J. Electrochem. Soc.*, 135, 321 (1988)
6. E. McCafferty, *Corros. Sci.*, 37(3), 481 (1995)
7. P. M. Natishan, E. McCafferty, G. K. Hubler, *J. Electrochem. Soc.*, 133, 1061 (1986)
8. Z. Szlarska-Smialowska, *Corros. Sci.*, 33 (8), 1193 (1992).
9. M. A. Petrunin, V. D. Gil'dengorn, T. A. Yurasova, G. V. Kuryavtsev, A. P. Nazarov, V. V. Lisichkin, *Russian J. of Phys. Chem.*, 66(9), 1323 (1992)
10. A. P. Nazarov, M. A. Petrunin, Yu. N. Mikhailoskii, *Protection. of Metals*, 28(4), 432 (1992)
11. M. A. Petrunin, V. D. Gil'dengorn, A. P. Nazarov, *Protection of Metals*, 30(2), 130 (1994)
12. J. J. Bernstein and White, *J. Electrochem. Soc.*, 131(5), 1050 (1984).
13. N. P. Miller, J. C. Berg, *Colloid and Surfaces*, 59, 119 (1991)
14. R. Alwitt, *Colloid and Interface Science*, 40(2), 195 (1972).
15. J. Waldrop and M. Kendig, *J. Electrochem. Soc.*, 145(1), L11 (1998).
16. T. Suter, H. Bohni, *Electrochim. Acta*, 42, 3275 (1997).
17. M. Kendig, R. Addison, S. Jeanjaquet, "The Influence of Oxo-Cr(VI) Species on the Zeta Potential in the Porous Oxide of Anodized Aluminum", *J. Electrochem. Soc.*, 146(12), 4419 (1999)
18. J. Ramsey, L. Xia, M. Kendig, R. McCreery, "Raman spectroscopic Analysis of the Speciation of Dilute Chromate Solutions", *Corrosion Science* 43(8), 1557 (2001)
19. E. Akiyama and G. S. Frankel, submitted to *J. Electrochem. Soc.*, 1999
20. G. O. Ilevbare, J. R. Scully, *Corrosion*, 57(2), 134 (2001)
21. G. Ilevbare, C. Jeffcoate, J. R. Scully in 'Passivity and Localized Corrosion, Sato Symposium, ECS PV 99-27, 269 (1999).
22. G. Ilevbare, J. R. Scully, *J. Electrochem. Soc.*, 148(5), 196 (2001).
23. J. R. Scully, T. O. Knight, R. G. Buchheit, E. E. Peebles, *Corros Sci* 35, 185 (1993).
24. R.G. Buchheit, R.P. Grant, P.F. Hlava, B. McKenzie, G.L. Zender, *J. Electrochem. Soc.*, 144, 2621 (1997).
25. V. Guillaumin and G. Mankowski, *Corr. Sci.*, 41, 421 (1999).
26. R. Buchheit, M. A. Martinez and L. P. Montes, *J. Electrochem. Soc.*, 147:(1) 119-124 (2000)
27. M. Kendig, R. Buchheit, H. Guan, R. Leard "Electrochemical Aspects of Dealloyed Al₂CuMg" Proceedings of the Electrochemical Society, April 2001.

28. M. Kendig, S. Jeanjaquet, R. Addison and J. Waldrop, *Surf. Coat. Tech.*,140(1), 58 (2001).
29. M. Kendig and S. Jeanjaquet “Cr(VI) and Ce(III) Inhibition of Oxygen Reduction on Copper”, to be published, *J. Electrochemical Society* (2001)
30. W. Clark and R. McCreery, “Inhibition of Corrosion-related Reduction Processes via Chromium Monolayer Formation”, to be published, *J. Electrochem. Soc.* (2001)

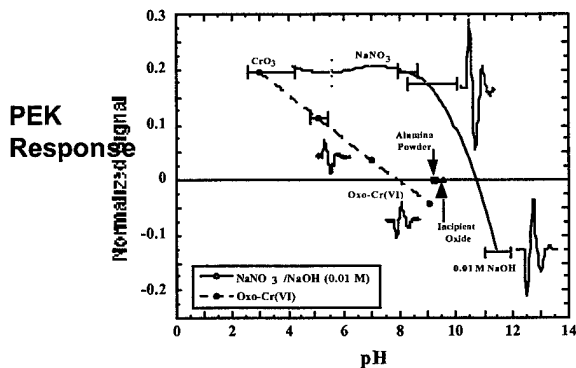

Figure 1. PEK response (relative amplitude) as a function of pH. The sign is determined by the phase.

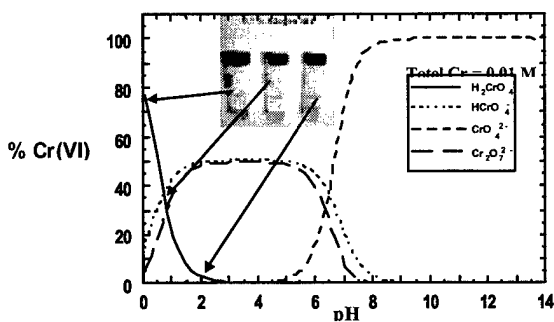

Figure 2. Calculated distribution of oxo-Cr(VI) species and a photograph of the extraction of ion pair chromate complexes from an aqueous phase to an organic phase using the Adogen 464 quaternary ammonium phase transfer catalyst. Note that when the chromate anion is sufficiently protonated at pH 0-1, no anion extraction into the upper organic phase occurs.

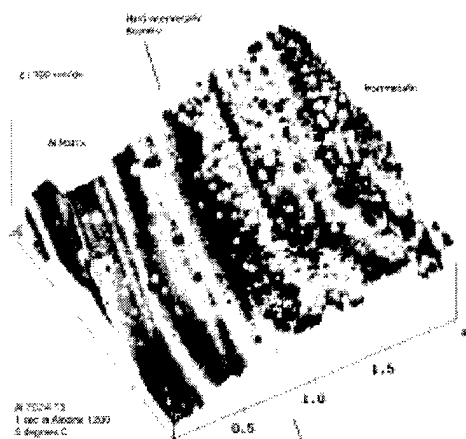
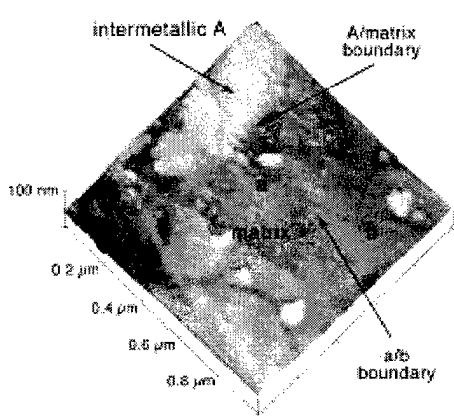

Figure 3. Two AFM images showing the nucleation stages resulting in the formation of chromate conversion coating on the cathodic Cu,Fe,Mn aluminides.

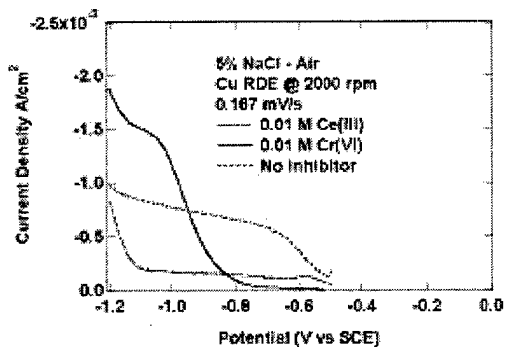

Figure 4. Current density vs potential for the cathodic polarization of a Cu RDE in 5% aerated NaCl containing 10 mM of Ce(III) or Cr(VI) inhibitors. The pH is 6.1.

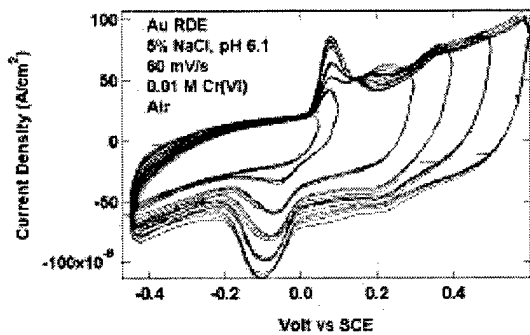

Figure 5. Cyclic voltammogram for a gold RDE (2000rpm) in the presence of Cr(VI) at pH 6. This is for the region where oxygen inhibition occurs. As can be seen peaks representing sub-monolayer electro sorption and desorption of an activated Cr(III) appear.

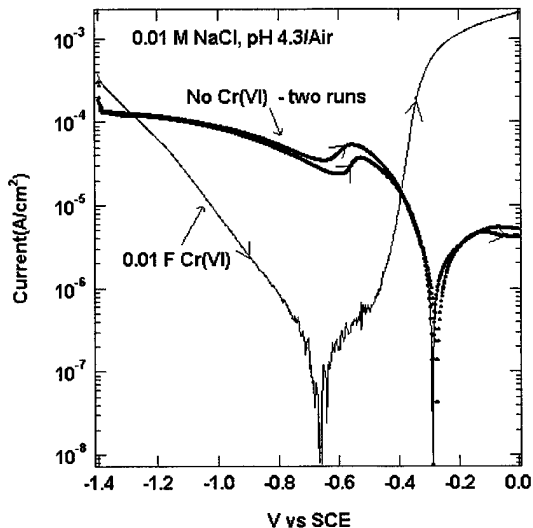

Figure 6. Polarization curves for Cu,Mg aluminide single crystal microelectrodes in pH 4.3 0.01 M NaCl. Scan rate is 10 mV/s cathodic to anodic potential.

5.4 Technical Summary of the Group at Brookhaven National Lab

5.4.1 Behavior of Passive Films on Al in Different Aqueous Environments

Little is known about the effects of different anions on the behavior of the passive film on Al. Chloride ions show a particular behavior that leads to the disruption of the film and soluble dissolution products at highly localized sites. The causes of breakdown are not known but with different electrolyte compositions or altering the preparation of the passive film distinct changes take place.

It has now been shown using simple cyclic polarization measurements of Al in different electrolytes that the passive film is in a dynamic state when exposed to most aqueous solutions. There are a few specific conditions where the film is highly stable, for example weak neutral electrolytes such as borate at near neutral pH and room temperature, but this is generally not the case. Chromate offers the same film stability under these particular conditions, but as shown in the examples below, with any changes in pH or temperature dramatic changes in the behavior of Al can take place.

Figure 1 shows the effect of pH on the development of the oxide film. At pH 3.9 and 7.0 the passive film grows rapidly during the first cycle. The film continues to thicken with each cycle reducing the current. However, at pH 9 after the first formation of the film the subsequent cycles show large currents above -1 V and a distinct repetitive hysteresis. The repetitive nature

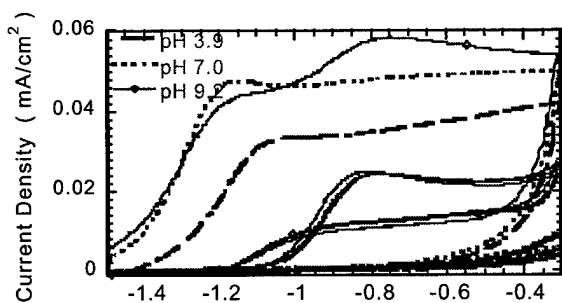

Figure 1. Cyclic polarization of pure Al in 0.5 M K_2CrO_4 at 20 °C and pH 3.9, 7.0 and 9.2.

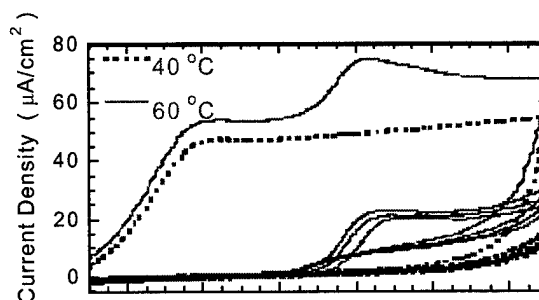

Figure 2. Cyclic polarization of pure abraded Al in 0.5 M K_2CrO_4 , pH 7.0 at 40 and 60 °C.

of the currents demonstrates that the passive film dissolves in the slightly alkaline chromate solution. During pitting of Al in dilute chloride solutions the increase pH when chromate is present may lead to dissolution of the passive film where the pH is elevated and contribute to a drop in potential to where pitting will not take place.

The effect of chromate is due to the presence of the monochromate. The dichromate is the stable species at neutral and acidic pH and also at higher temperatures. With temperature, at 60

°C the shape of the curve changes dramatically and produces effects distinctly similar to results at 20 °C with a pH of over 9 due to the monochromate.

5.4.2 The Source of Electrochemical Noise During Pitting Corrosion

Transients in either potential or current measured respectively at the open circuit corrosion potential have been interpreted in terms of passivity breakdown, pit propagation and repassivation processes. When pitting occurs in stainless steels, the kinetics can be derived from the cathodic characteristics of the passive surface during initiation, propagation, and repassivation. With Al, the correlation with the electrochemical behavior of the passive surface during pitting has not been clearly elucidated. There are sharp potential transients with periods of 1-5 seconds that have been interpreted in terms of metastable pits but it has not been at all clear why the corrosion potential of Al tends to meander with a frequency of about 1/50 Hz.

Figure 3 is an example of the behavior of Al in 50 mM NaCl. Two separated and interconnected Al samples were used and the current flowing between them was monitored. The potential increases with time. At times before 300 s, a few sharp transients occur on both surfaces. After that, the current indicates chaos and the potential begins to meander.

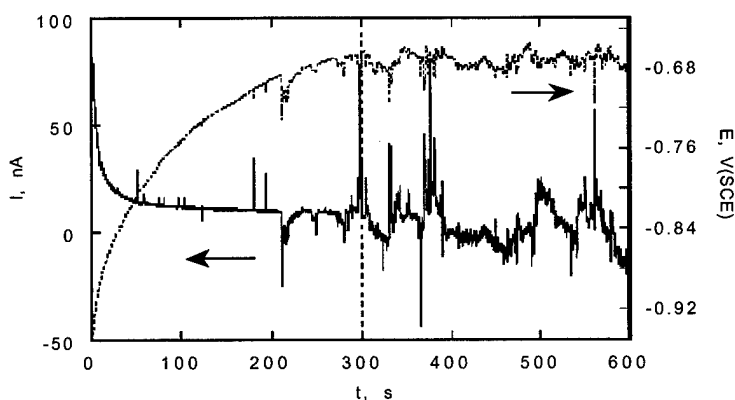

Figure 3. Electrochemical noise measurement for Al in 50 mM NaCl.

Figure 4 is an example of the current flowing between three separated surfaces in agar gel with 50 mM NaCl. The gel contained a wide range pH indicator to locate active pits. Up to 150 s, area 3 was pitting as shown by the anodic current and an observed single pit. Areas 1 and 2 showed the same cathodic currents. After 150 s a pit appeared on surface 2. The use of the three interconnected surfaces and pH visualization showed that up to 150s single meta-stable pits produced the transients similar to stainless steels. However, when more than one active pit was present, the currents flowing increased dramatically between the pits and not to areas that were fully passive.

Hence, the meandering and rapid transient kinetics processes during Al pitting are dominated by the interaction between active pits and the within the pits and not meta-stable events. The pit growth transients are caused by tunnel process within active pits.

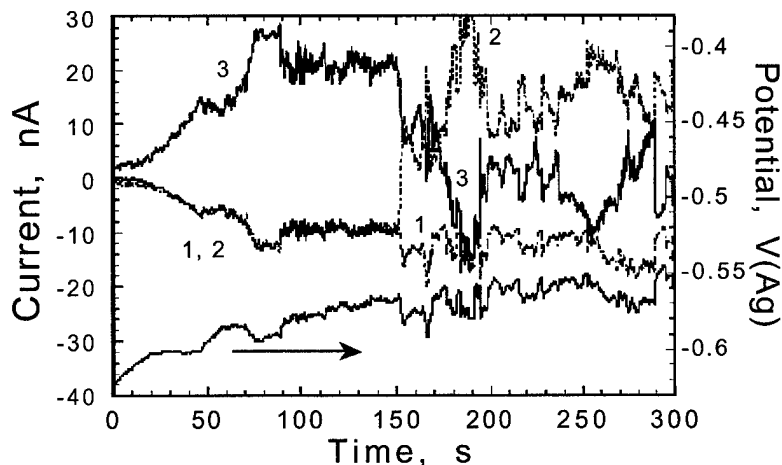

Figure 4. Electrochemical noise measurement for 3 Al samples in agar gel with 50 mM NaCl.

5.4.3 In situ XANES Study of Chromate Conversion Coatings Formation on Al and Al Alloys

X-ray absorption near-edge structure (XANES) offers a powerful method for the *in-situ* study of the inhibiting effects of chromate in solutions and the chromate conversion coatings (CCC) films. The ratio Cr(VI)/Cr(total) is obtained from the ratio of the Cr(VI) pre-edge peak height at 5993 eV to the total absorption edge height. Alodine solution was brought in contact with the specimen when a very thin membrane was inflated and the reaction with the sample was stopped when the cell was deflated by drawing the membrane in close contact with the surface. The cell is shown in Figure 5.

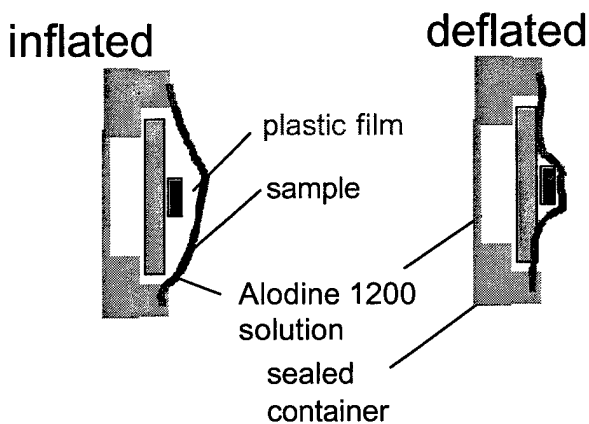

Figure 5. The cells designed to obtain XANES spectra of the stepwise growth of the CCC film on Al and its alloys.

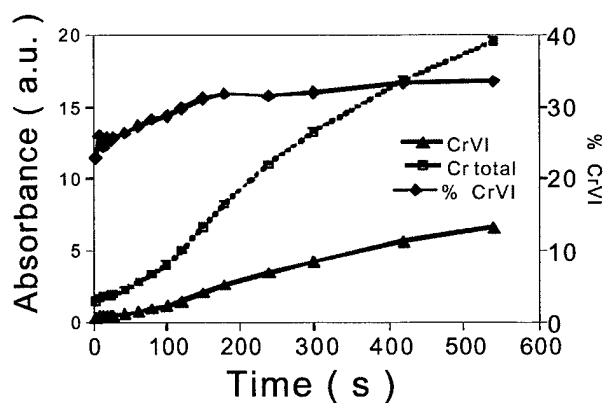

Figure 6. The buildup of Cr(VI), Cr(total) and % Cr(VI) on AA2024 with contact time.

Figure 6 shows the buildup of the Cr(VI), the total Cr, and the %Cr(VI) obtained from these values. The buildup of the CCC layer continues to increase up to 10 minutes for AA2024. For

AA1100 the total Cr levels off after about 300s. Generally the %Cr(VI) stays approximately constant after 200 s. The %Cr(VI) is initially high but decreases with time for AA1100, increases with time for AA2024 and remains approximately constant with time for AA7075. Considering that the differences were due to differences in Cu content in the alloys, XANES measurements were performed on a series of binary Al-Cu alloys (0.2-4 % Cu). All the Cu alloys exhibited initial high concentrations of Cr(VI) at the beginning of solution immersion that decreased for the first 300 s. Hence, the changes in Cr(VI) concentration is independent of Cu content. However, the amount total Cr continued to increase with time and this behavior appears to be a function of the Cu in the alloy and prevents the formation of a limited thickness of CCC.

5.5 Technical Summary of the Group at State University of New York at Stony Brook

5.5.1 Radiation damage of chromate conversion coatings during x-ray photoelectron spectroscopy

The recent discovery of photochemical reduction of Cr(VI) to Cr(IV) (and subsequently to Cr(III)) during XPS analysis of chromate-containing surfaces had complicated the process of surface analysis and had, in fact, brought into question the accuracy of many previous XPS measurements of Cr speciation. The reduction of CrO_4^{2-} is greatly accelerated by the presence of surface hydrocarbons originating from either the rotary pump or diffusion pump in the vacuum system. However, elimination of all sources of hydrocarbons from rotary and diffusion pumps has been found to reduce the photochemical reduction of hexavalent chromium in CrO_4^{2-} to below measurable levels. This has been accomplished through the use of sorption pumps for rough pumping and replacement of diffusion pumps with ion pumps.

Chromate conversion coatings (CCC) contain well-hydrated trivalent chromium oxides with varying amounts of hexavalent chromium oxides. The water and hydrocarbons in commercial CCCs adversely affects the stability of Cr(VI) during exposure to soft x-rays. The breakdown of $\text{Cr}_2\text{O}_7^{2-} \cdot 2\text{H}_2\text{O}$ to CrO_4^{2-} , CrO_3 , and $\text{Cr}(\text{OH})_3/\text{CrOOH}$ was found to occur during XPS analysis. Use of hydrocarbon-free pumping techniques and cooling of the sample stage with liquid nitrogen during analysis resolved the problem. Similarly, cooling a chromate conversion coated alloy samples with liquid nitrogen provided for a more accurate determination of the Cr(VI)/Cr(III) in the coating. Although some reduction of Cr(VI) to the intermediate Cr(IV) was observed. The susceptibility of Cr(VI) in CCC to reduction is attributed to cyanide and other organics such amides.

Using the ultra-clean vacuum pumping practice recently developed, it was possible to prevent photochemical reduction over the periods needed for XPS analyses. The medium weight (coating density = $54 \text{ mg}/\text{ft}^2$) chromate conversion coatings on AA2024-T3 studied under liquid nitrogen cooled and hydrocarbon-free pumping conditions, showed that hexavalent chromium forms ~ 50% of the total Cr species. Under conventional analysis conditions, only ~32% of the Cr species appear to be hexavalent due to photoreduction, which agrees well with most other studies. Chromium spectra obtained from XPS of the chromate conversion coatings on AA2024-T3 alloys have for the first time been fitted with six species of chromium compounds, thereby providing a highly accurate determination of the chromium composition. No evidence of beam damage to CCC components was found by synchrotron infrared spectroscopy (SIRS) or extended x-ray analysis of fine structure (EXAFS).

5.5.1.1 *References:*

1. "Causes and prevention of photochemical reduction of hexavalent chromium during x-ray photoelectron spectroscopy", S. V. Kagwade, C. R. Clayton and G. P. Halada, *Surf. Interface Anal.*, **31**, 442–447 (2001).

2. "Development of a Technique to Prevent Radiation Damage of Chromate Conversion Coatings During X-Ray Photoelectron Spectroscopic Analysis", D. Chidambaram, G. P. Halada and C. R. Clayton, *App. Surf. Sci.*, **181**, 283-295 (2001).

5.5.2 Studies on the Surface Preparation of AA2024-T3

Variable angle x-ray photoelectron spectroscopy (VAXPS) indicated the presence of copper, which corresponds to other reports of Cu redistribution across a dissolving AA2024-T3 surface. It is also possible that the Cu is a contaminant from the polishing processes, since there are polishing suspensions that contain traces of copper. Acetone, when used as a degreasing agent for copper in the presence of ambient light and water vapor, was shown using x-ray Photoelectron Spectroscopy (XPS) to slowly react to form acetic acid. This reaction did not occur in the absence of light. This suggested that copper acted as a photocatalyst for the reaction between acetone and water vapor. Hence the effects of acetone and isopropanol were studied on AA2024-T3 because they are widely used as cleaning agents as a part of surface preparation and AA2024-T3 indicated the presence of surface copper. Using electrochemical polarization and XPS, it was shown that acetone reacts with a bare surface of AA2024-T3 in the presence of 0.5M NaCl solution to compromise passivity of the alloy and form aluminum acetate and copper chloride. Fourier transform infrared microspectroscopy at National Synchrotron Light Source (NSLS) of the Brookhaven National Laboratory (BNL) was also used to aid in identification of surface species. Hundreds of individual FTIR spectra were taken over a range of wavelengths and on a certain area. Maps were then made by windowing different regions of the spectra, such as the hydroxyl- and cyano- bonds. These bonds were found to be heterogeneously distributed across the surface. The same method showed that pits in 2024-T3 cleaned with acetone and then exposed to humid salt environments contained copper acetates, which supports earlier work on the role of acetone in pit initiation. A model for this is shown in fig 1. As a result of this work, it is recommended that unanodized aluminum alloys bearing copper should not be cleaned with acetone for applications in an environment containing aqueous NaCl.

5.5.2.1 *References:*

1. "The Effect of Acetone Cleaning on the Corrosion Characteristics of AA2024-T3 in a Mist of 0.5 M NaCl, S. V. Kagwade, C. R. Clayton," *Passivity and Its Breakdown*, P. M. Natishan, H. S. Isaacs, M. Janik-Czachor, V. A. Macagno, P. Marcus, and M. Seo (Ed), Proceedings Volume 97-26, p.631, The Electrochemical Society, Pennington, NJ (1997).
2. "Photochemical Reaction of Organics on Copper and Copper-Containing Aluminum Alloys", C. R. Clayton, G. P. Halada, and S. V. Kagwade, *Critical Factors in Localized Corrosion III*, R. G. Kelly, P. M. Natishan, G. S. Frankel and R. C. Newman (Eds.) Proceedings Volume 97-17, p.223, ECS, Pennington, NJ (1999).
3. "The Influence of Acetone Degreasing on the Corrosion Behavior of AA2024-T3", S. V. Kagwade, C. R. Clayton, D. Chidambaram, M. L. Du, and F. P. Chiang, *J. Electrochem. Soc.*, **147**, 4125-4130 (2000)
4. "Photochemical Breakdown of Acetone on Copper", S. V. Kagwade, C. R. Clayton, D. Chidambaram and G. P. Halada, *Electrochimica Acta*, **46**, 2337-2342 (2001).

5. "Infrared Microspectroscopic Studies on the Pitting of AA2024-T3 Induced by Acetone Degreasing", D. Chidambaram and G. P. Halada, *Surface and Interface Analysis*, **31**, 1056-1059 (2001).

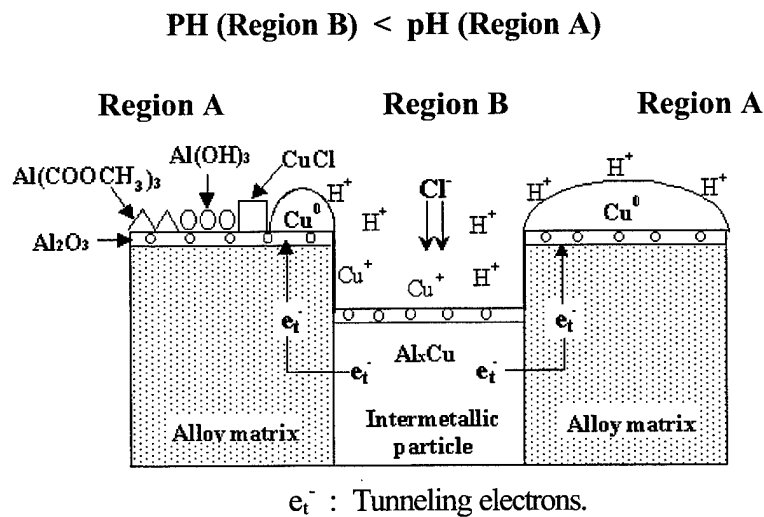

Fig. 1. Schematic of the mechanism for the deposition of copper on the surface of AA2024-T3 rinsed with acetone and isopropanol and exposed to a mist of 0.5 M NaCl solution.

5.5.3 Effect of Surface Pretreatments of AA2024-T3 on the Composition of Chromate Conversion Coatings

Anodized films of 7-150 nm thickness (as measured by ellipsometry), formed in a neutral borate buffer, were exposed to chromate-containing solutions and studied by surface analytical techniques to establish the influence of oxide thickness on the degree of chromate reduction. A 70nm anodized film was grown and exposed to a hexavalent chromium solution (neutral 10mM K_2CrO_4 for 1 hr at room temperature). XPS analysis showed that this film contained solely trivalent Cr species. Ultra-clean practices on photoreduction of Cr(VI) were followed during XPS analysis.

The presence of residual contaminants (e.g. cleaning agents, metal working fluid, ink) affected the distribution of activator compounds (e.g. ferricyanide) in a CCC. A nascent CCC retained most of the surface chemical features (bound hydrocarbons, heterogeneity of CN, bound water) of the pretreated substrate. The cyanide complex on the outermost surface of the nascent CCC was identified, by reference to FT-IR standards, as Cr(III)-Fe-CN₆.

The effects of various pretreatments to AA2024-T3 were also studied. These treatments include various chemical treatments, mechanical treatments, and electropolishing. Several of the treatments resulted in concentration of Cu at the surface, but there was no correlation between the Cu concentration and polarization resistance. The influence of a number of surface pretreatments to AA2024-T3 on the properties of the CCC subsequently formed was studied

by using the cold Alodine conversion coating (CACC) approach. In this approach, the sample is exposed to cold Alodine bath ($T < 5^{\circ}\text{C}$) for a period of seconds, thereby forming only a very thin film of conversion coating. The nature of oxide film resulting from the pretreatments and its influence on the total amounts of hexavalent chromium in these coatings was also investigated using XPS and x-ray analysis near edge spectroscopy (XANES). Electrochemical Impedance Spectroscopy (EIS) was also performed on the various pretreated alloy samples to evaluate the polarization resistance of the various oxide films. The Cr(VI)/Cr(III) ratio varied with the method of surface preparation. The composition of the surface film formed on AA2024-T3 varied significantly with the type of pretreatment. The thickness of the film varies inversely with the amount of $\text{Al}(\text{OH})_3$ in the surface film. Results indicate there could exist an inverse correlation between the polarization resistance of the pretreated AA2024-T3 and hexavalent chromium content in the CCC later formed on it. There also appears to be a direct correlation between the ratio of $\text{Al}(\text{OH})_3/\text{Al}_2\text{O}_3$ in the pretreated sample and the amount of hexavalent chromium present in the CCC. This could also be due to the fact that stable Al(III)-Cr(VI) compounds being formed in the pits, scratches or "valleys" residual after the pretreatment, as explained later.

A collaborative work on organochromates in polymer coating systems with Granata (Lehigh/FAU) aimed to determine: (a) whether chromate pigments react with resins to enhance barrier properties, (b) the dependency of CCC/polymer interface stability on pretreatment and primer and the pigmentation of the was also important, (c) similarities in the inhibitory mechanism of chromate in the paint vs. a CCC. Using SIRS at NSLS, aliphatic hydrocarbons and epoxides were found to be concentrated near the alloy/coating interface. Chromate species in low chromate coatings (828 and 828/3141) were concentrated near the alloy/coating interface, likely due to diffusion from the chromate conversion coating. Chromate in the higher chromate concentration coatings (828+10% CrO_4 and DEFT) are distributed throughout the coating. The addition of chromate to the 828 coating appeared to cause dilution and spreading of epoxide from the alloy/coating interface, which was attributed to the interaction of pigment chromate with the epoxy

5.5.3.1 References:

1. "Effect of Surface Pretreatments on Chromate Conversion Coatings" D. Chidambaram, C. R. Clayton, G. P. Halada and Jeffery R. Kearns, in *State-of-the-Art Application of Surface and Interface Analysis Methods to Environmental Material, Interactions*, D.R. Baer, C.R. Clayton, G.P. Halada, and G.D. Davis, Eds, PV 2001-01, The ECS Proceedings Series, Pennington, NJ (2001).
2. Micro XANES Study of Chromate Conversion Coating Homogeneity and Aging on AA2024-T3 (Beamline X26A)," G. Halada, J. R. Kearns, C. R. Clayton, M. W. Kendig, S. Jeanjaquet, R. D. Granata, and Grace-Shea McCarthy, National Synchrotron Light Source Activity Report 1998, National Technical Information Service, Springfield, VA, 1998.

5.5.4 Composition of Intermetallic Compounds, Thin Film Analogs of Intermetallic Constituents and Chromate Conversion Coatings Formed on them and Effects of aging on these coatings

Secondary ion mass spectroscopic (SIMS) mapping of alodine-treated 2024-T3 showed that the coating contains small amounts of all of the major alloying elements (Fe, Cu, Mn, Mg) that are inhomogeneously distributed across the surface. A variety of surface analytical techniques were used to characterize bulk samples of intermetallic compound analogs given a cold alodine coating, as described above. Differences were observed in the surface films formed on Al_2Cu and Al_2CuMg samples. It was also shown that the Cr concentration and distribution on intermetallic compounds is different from that on matrix regions.

The combination of dynamic SIMS and SIRMS revealed dissimilarities in the depth distribution of CCC components. The results support findings that the CCC is inhomogeneously distributed across the AA2024-T3 surface. Potassium appeared to form an insoluble salt on the CCC surface thus increasing heterogeneity.

Several highly homogeneous thin films of intermetallic compounds found on AA2024-T3 alloy were created by femtosecond and excimer laser ablation. These thin film analogs were exposed to different chemical environments and then characterized by various surface sensitive techniques including SIMS and SIRMS. The nascent CCC formed on the thin film analog surfaces was characterized to reveal the influence of IMC on CCC structure and composition. In a second set of experiments the thin film analogs were exposed to CCC accelerators such as ferricyanide ($\text{Fe}(\text{CN})_6^{3-}$) in order to better understand CCC formation.

Surface chemical data have been developed to refine an existing model for the Chromate Conversion Coatings (CCC) formed on the AA2024-T3 surface. It was necessary to develop samples of large areas containing compositional homogenous thin films of the various IMCs found on the AA2024-T3 surface in a two-step process. First, disks of IMC compositions were formed by Reactive Arc Melting (RAM). SEM/EDAX and XRD results revealed that these RAM analogs were very close to the desired compositions, exhibiting local areas of compositional variation only at grain boundaries. In the second stage, femtosecond laser ablation of the RAM IMCs disks was found to produce homogenous thin films. These thin films were used to analyze the behavior and formation of CCC on IMCs and Sanchem treated AA2024-T3. SIMS depth profile revealed significant variations of CCC film formation and minor constituent composition derived from underlying IMCs. The SIMS results also indicated that the CCC formed on the θ phase was about 9% and S phase was about 15 % of the average thickness of the CCC formed on the AA2024-T3 surface. The CCC thickness on the $\text{Al}_{20}\text{Cu}_2(\text{MnFe})_3$ was found to be variable having thin and thick islanded structure. These results indicate that the thickness of the CCC appears to diminish with the increasing Cu content of the substrate. $\text{Fe}(\text{CN})_6^{3-}$ retention increased with Cu content of the substrate inhibiting the Al^{3+} production for CCC formation. A comprehensive model for this is shown in fig 2.

An explanation for the CCC aging phenomenon, known to delay commercial coating production, was sought by a combination of XANES, SIRS, and EXAFS analyses. Chromate reduction was not a significant factor to CCC aging over a 24-hr period, but surface dehydration and structural change were correlated and causative. A reduction in surface Cr(VI)/ Cr(III) ratio was observed over a longer aging period (35 days).

The influence of the structure of CCC formed on AA2024-T3 and on IMC constituents of AA2024-T3 as a function of aging was studied. EXAFS, XANES and contact angle measurements were used to monitor the structural changes and surface wetness respectively of the CCC with time. It was observed that the different IMCs have little effect on the structural changes that occur in the CCC, though in all cases, a slight decrease in the Cr(VI) to Cr(III) ratio occurred during the first 24 h following coating. EXAFS data in all cases indicated that the CCC is similar to the Cr mixed oxide compound proposed by McCreery et al. and that there is an increase in ordering in the CCC structure with time. There was an increase in hydrophobicity of CCC on intermetallic thin films within 24 h of aging as observed by contact angle measurements. The CCC structure seems to have a similar behavior when formed on both individual and galvanic coupled IMCs.

5.5.4.1 Reference

1. "Spatially-Resolved Microchemical Analysis of Chromate Conversion Coated Aluminum Alloys and Constituent Intermetallic Particles", G. P. Halada, C. R. Clayton, M. J. Vasquez, and J. R. Kearns, M. W. Kendig, S. L. Jeanjaquet, G. G. Peterson, G. Shea McCarthy, G. L. Carr, G. P. Williams, and L. M. Miller, *Critical Factors in Localized Corrosion III*, R. G. Kelly P. M. Natishan, G. S. Frankel and R. C. Newman (Eds.) Proceedings Volume 98-17, p.139, ECS, Pennington, NJ (1999).
2. "Composition of Surface Treated Thin Film Analogs of Intermetallic Constituents in AA2024-T3", M. J. Vasquez, G. P. Halada, C. R. Clayton and J. P. Longtin, in *Corrosion and Corrosion Prevention of Low Density Metals and Alloys*, B.A. Shaw and R.G. Buchheit, Eds, PV 2000-23, p57, The ECS Proceedings Series, Pennington, NJ (2001).
3. "Studies on the Structure and Formation of Chromate Conversion Coatings on Thin Films of Copper-Containing Intermetallic Constituents in AA2024-T3", M. J. Vasquez, G. P. Halada, C. R. Clayton", M. J. Vasquez, G. P. Halada and C. R. Clayton, in *State-of-the-Art Application of Surface and Interface Analysis Methods to Environmental Material, Interactions*, D.R. Baer, C.R. Clayton, G.P. Halada, and G.D. Davis, Eds, PV 2001-01, The ECS Proceedings Series, Pennington, NJ (2001).
4. "Hydrophobicity and Structural Stability During Aging of Chromate Conversion Coatings on Al Alloys", C. R. Clayton, G. P. Halada, M. J. Vasquez, J. R. Kearns, D. Chidambaram, and R.D. Granata, *Passivity and Localized Corrosion*, M. Seo, B.MacDougall, H. Takahashi and R.G. Kelly (Eds.) Proceedings Volume 99-27, p.290, The Electrochemical Society, Pennington, NJ (1999).
5. "Effects of Aging on Chromate Conversion Coatings Formed on AA2024-T3 and Some Intermetallic Constituents", M. J. Vasquez, G. P. Halada, C. R. Clayton and J. P. Longtin, in *Corrosion and Corrosion Prevention of Low Density Metals and Alloys*, B.A. Shaw

and R.G. Buchheit, Eds, PV 2000-23, p101, The ECS Proceedings Series, Pennington, NJ (2001).

6. "Study of Chromate Conversion Coatings Formed on AA2024-T3 and Thin Film Analogs of Intermetallic Constituents", M. Vasquez, G. P. Halada, C. R. Clayton and J. P. Longtin, Submitted to *Journal of Electrochemical Society* (2001).
7. "Synchrotron Infrared Microspectroscopy of Chromate Conversion Coated Interfaces", M. Vasquez, J. R. Kearns, G. P. Halada and C. R. Clayton, Submitted to *Surface and Interface Analysis* (2001).
8. "Spatially Resolved Microchemical Analysis of Chromate Conversion Coated AA2024-T3", M. Vasquez, J. R. Kearns, G. P. Halada and C. R. Clayton, Submitted to *Surface and Interface Analysis* (2001).
10. "Application of Synchrotron Spectroscopic Techniques to the Study of Protective Corrosion Layers", M. Vasquez, G. P. Halada and C. R. Clayton, Submitted to *Electrochimica Acta* (2001). *Review paper.*

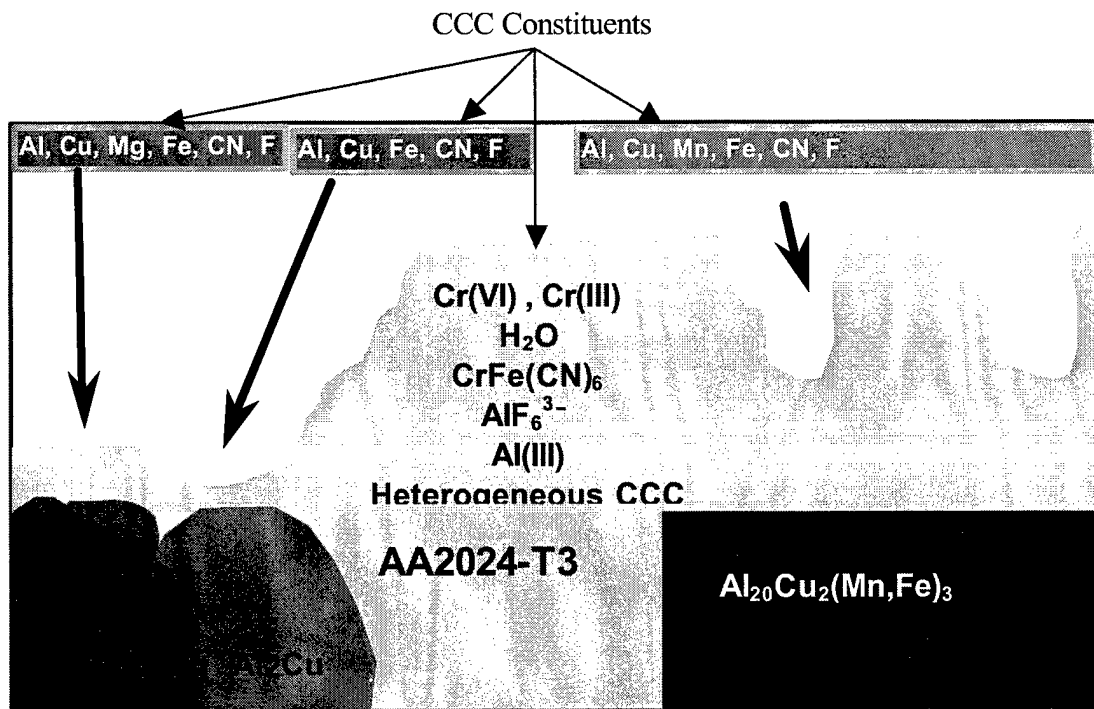

Fig. 2. Model for composition of Chromate Conversion Coating on AA2024-T3

5.5.5 Bipolar Mechanism for Chromate-Induced Repassivation of Active Sites on Aluminum and Repassivation behavior of Chromate Conversion Coated AA2024-T3.

A novel investigation of the passive film formed on AA1060 has been made to determine whether the interaction of CrO_4^{2-} on an Al alloy is analogous to MoO_4^{2-} on stainless steel. Aluminum hydroxide was first formed by immersion of ion cleaned AA1060 in water and then exposed to chromate and chloride solutions. Both chromate and chloride ions were seen to lead to a structural change in the hydrated aluminum anodic film consistent with deprotonation or dehydroxylation. Chromate adsorption appears to induce deprotonation of the hydrated aluminum anodic film consistent with the bipolar model. Cr(VI) enrichment in the valleys is consistent with the possible formation of an Al(III)-Cr(VI) compound according to the McCreery pit repassivation model. A new duplex model incorporating both the Sato-bipolar model and McCreery-pit repassivation model was proposed and is shown in fig. 3.

The electrochemical behavior of the intermetallic particles when exposed to individual chemicals found in chromate conversion coating solutions such as dichromate and ferricyanide were studied in order to better understand the corrosion process occurring on AA2024-T3. To model the AA2024-T3 matrix, intermetallic particles were also individually coupled with Al (99.995%) in some cases prior to electrochemical studies. Open Circuit Potential (OCP) measurements and potentiodynamic polarization were performed on these systems in 0.05 M NaCl solution. The electrochemistry of AA2024-T3 appeared to be dominated by that of Al_2Cu , with and without chromate. This indicated that poor chromate coverage of Al_2Cu on AA2024-T3 leads to localized attack at Al_2Cu particles. Ferricyanide is observed to have minimal effect in terms of both corrosion potential and current on all systems.

To elucidate whether the interaction of $\text{Cr}_2\text{O}_7^{2-}$ on aluminum alloy surfaces is in certain aspects analogous to that of MoO_4^{2-} on stainless steels, the electrochemical behavior of AA2024-T3 and two intermetallic particles Al_2Cu and Al_2CuMg were studied with and without pretreatments with molybdate solution. These results were compared with those performed with a pretreatment using a similar concentration of dichromate solution. In general, chromate is observed to inhibit the cathodic kinetics in aerated 0.05 M NaCl while molybdate has no effect. However, repassivation by molybdate is observed to be much faster than that by dichromate. The corrosion potential of Al_2Cu is not significantly affected by chromate or molybdate and both reduce the corrosion current only marginally. The electrochemistry of AA2024-T3 and Al_2Cu appear to be similar with and without chromate or molybdate. Al_2Cu developed a bluish-brown film on the surface after cathodic polarization in 0.05M NaCl. Using SIMS, this film was found to be enriched in the amount of copper compared to unpolarized Al_2Cu .

Self-healing properties of chromate conversion coating have been associated with migration of hexavalent Cr to actively corroding sites. Pure Al (99.9995%) was exposed to 0.025 M dichromate solution for 5min. The sample was then immersed in 0.05M NaCl and scratched. The repassivation of a scratch was then studied using OCP, SIRMS and SIMS. Results indicated that the dichromate ions had high mobility. The slow migration of Cr(VI) ions from the

protected surface to the scratch was observed to result in repassivation as seen from the steady increase in the potential in 0.5 M NaCl solution.

This work was then extended to explore the repassivation of a scratch on a chromate conversion coated AA2024-T3 using OCP measurements and SIRMS. Results indicated that hexavalent chromium had migrated to the scratched area.

5.5.5.1 References:

1. "On the Bipolar Mechanism for Chromate-Induced Repassivation of Active Sites on Chromate Conversion Coated Aluminum Alloys", C. R. Clayton, G. P. Halada, D. Chidambaram, and M. J. Vasquez, in *Passivity and Localized Corrosion*, M. Seo, B. MacDougall, H. Takahashi and R.G. Kelly (Eds.) PV 99-27, p.249, ECS, Pennington, NJ (1999).
2. "On the Electrochemical Behavior of Dichromate and Molybdate Treated Intermetallic Particles Present in AA2024-T3", D. Chidambaram, C. R. Clayton and G. P. Halada, in *Corrosion and Corrosion Prevention of Low Density Metals and Alloys*, B.A. Shaw, R.G. Buchheit and J. P. Moran, Eds, PV 2000-23, p69, ECS, Pennington, NJ (2001).
3. "Studies on the Repassivation Behavior of Aluminum Exposed To dichromate Solution", D. Chidambaram, C. R. Clayton and G. P. Halada, in *State-of-the-Art Application of Surface and Interface Analysis Methods to Environmental Material, Interactions*, D.R. Baer, C.R. Clayton, G.P. Halada, and G.D. Davis, Eds, PV 2001-01, The ECS Proceedings Series, Pennington, NJ (2001).

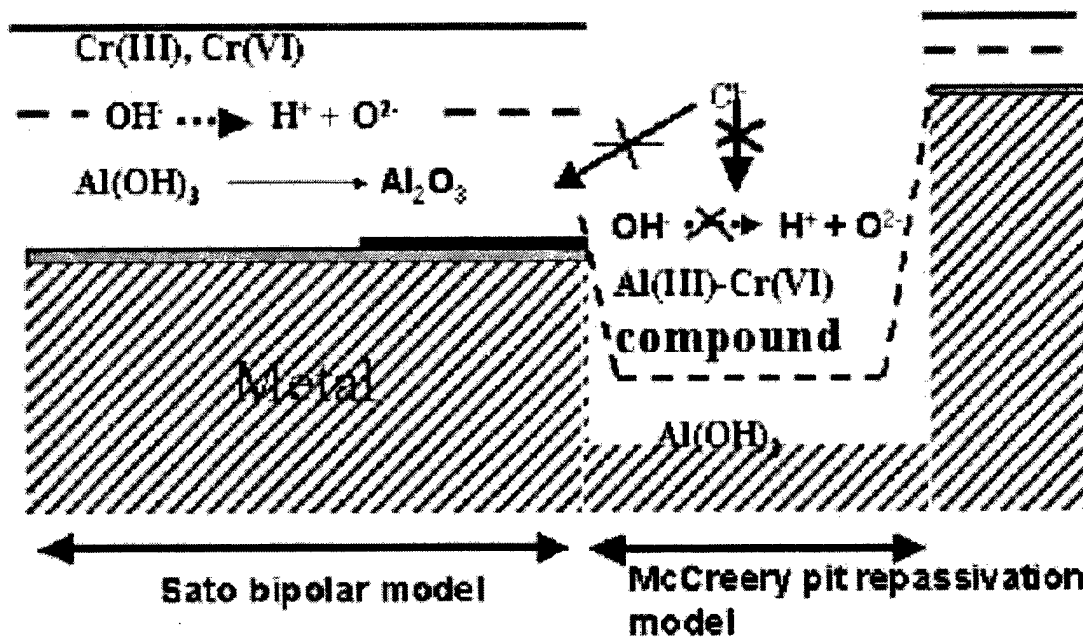

Fig 3. A new duplex model incorporating both the Sato-bipolar model and McCreery-pit repassivation model for passivity of aluminum.

5.6 Technical Summary of the Group at University of Erlangen and Max Planck Institute

Part of our work over the past 5-6 years has focussed on in-situ measurements of active filiform filaments on AA2024-T3 using the Scanning Kelvin Probe (SKP) technique. In these studies, SKP has been successfully used to identify the anodic head of an FFC filament, thereby supporting the accepted mechanism of 'anodic undermining' to describe filiform advancement. Furthermore, SKP can be used to observe changes in FFC behaviour under varying atmospheric conditions, providing yet further evidence as to the importance of oxygen in the corrosion mechanism.

One drawback of the standard SKP technique is the inability to resolve potential differences between intermetallics and the substrate in a commercial alloy such as AA2024-T3. To overcome this difficulty, the Scanning Kelvin Probe Force Microscopy (SKPFM) was employed. The major requirement for successful SKPFM resolution of intermetallics is an ultrathin (nanometer range) coating under which FFC can progress. With SKPFM, not only were intermetallics observable, but in-situ measurements could be carried out on alloy, as well as model samples. This SKPFM analysis provides evidence of the important role that Cu, as an alloy component, plays in the progression of FFC. The following report summarizes these results.

Other results which are not included in this report include:

- FFC growth rates decreased as the number of surface pretreatments applied increased.
- Copper and iron enrichments appeared on the alloy surface following Sanchem or Sanchem + CCC pretreatments
- The Sanchem pretreatment was not entirely effective at removing all intermetallics
- SKPFM analysis of CCC treated samples showed evenly distributed spots of high potential which, from TOF-SIMS analysis, may exist due to Cu and Fe surface enrichments.
- XPS and TOF-SIMS analysis showed that Cl enrichment existed in an active FFC head, which supports the electrochemical model for FFC corrosion.
- Pigmented coatings drastically reduce the widespread nature of FFC and resulting corrosion is much deeper than with the usual FFC.
- Chromate originating from pigments is much more mobile and deposited on Cu-containing intermetallics.
- A combination of pigmented coatings and the Sanchem pretreatment greatly increased the coating adhesion.

5.6.1 Filiform corrosion experiments – Tracking FFC

5.6.1.1 *Sample preparation and experimental procedure*

Aluminum alloy 2024-T3 samples were mechanically polished to 1 μm (diamond suspension before coating with Dicumylbisphenol A (DCBA), which was applied via spin-coating as an ultrathin film (applicable thickness 40-400 nm). FFC was initiated by placing a dilute NaCl or HCl solution in a scratch which pierced the coating. The samples were then stored at approx. 85% relative humidity.

5.6.1.2 *Scanning Kelvin Probe (SKP) measurements*

Some of the samples have been investigated with the SKP directly after coating and scratching. The measured corrosion potentials were taken as a reference for the uncorroded metal / polymer interface. Once FFC appeared, SKP measurements were performed at the same humidity as that in the storage chamber to ensure that the growing conditions for the FFC tracks were not altered. After the initiation of FFC, maps of the corrosion potential distribution were measured in intervals, if the sample showed visible delamination.

Such a FFC advancement track is illustrated in Figure 1. A potential hollow (about 30 to 50 mV lower than the surrounding intact interface) at the very front of the FFC track can be seen from the inserts in the potential map. This appears to be the active head of the track, where Al dissolution takes place. This potential hollow was not observed in every measurement, indicating that it may oscillate. The rest of the FFC track showed almost constant corrosion potentials between 100-150 mV_{SHE}. The direction of track growth is determined by the position of the potential hollow, as can be seen by looking at the growth progress at later times (Fig. 1).

5.6.2 Filiform corrosion experiments – Atmospheric Changes

5.6.2.1 *Sample preparation and experimental procedure*

All experiments and measurements were completed with polished samples coated with a "standard" transparent polyurethane resin or a epoxy-amine polymer film (10 to 100 μm). In order to examine atmospheric changes, N₂ was used to eliminate oxygen from the measurement cell. A relative humidity of approx. 85% was maintained.

5.6.2.2 *Scanning Kelvin Probe Investigations*

The most obvious difference in the results of the SKP measurements between the thin (DCBA, 400 nm) and the standard (> 10 μm) coatings is, that the potential hollow measured at the active head is much larger both in width and "depth" than with the thicker coatings. Another feature observed with the standard coatings is an intermediate potential region behind the head, approx. 100 mV anodic to the front part of the active head. The areas around this two-step potential hollow show almost the same corrosion potentials (Fig. 2, "air"), whether they are covered with corrosion products (inactive tail) or not (intact metal-coating interface). This observation is different from that on the sample with the thin DCBA film, where the tail of corrosion products

was characterized by the most anodic potentials and the intact interface showed potentials just slightly anodic to those of the active head.

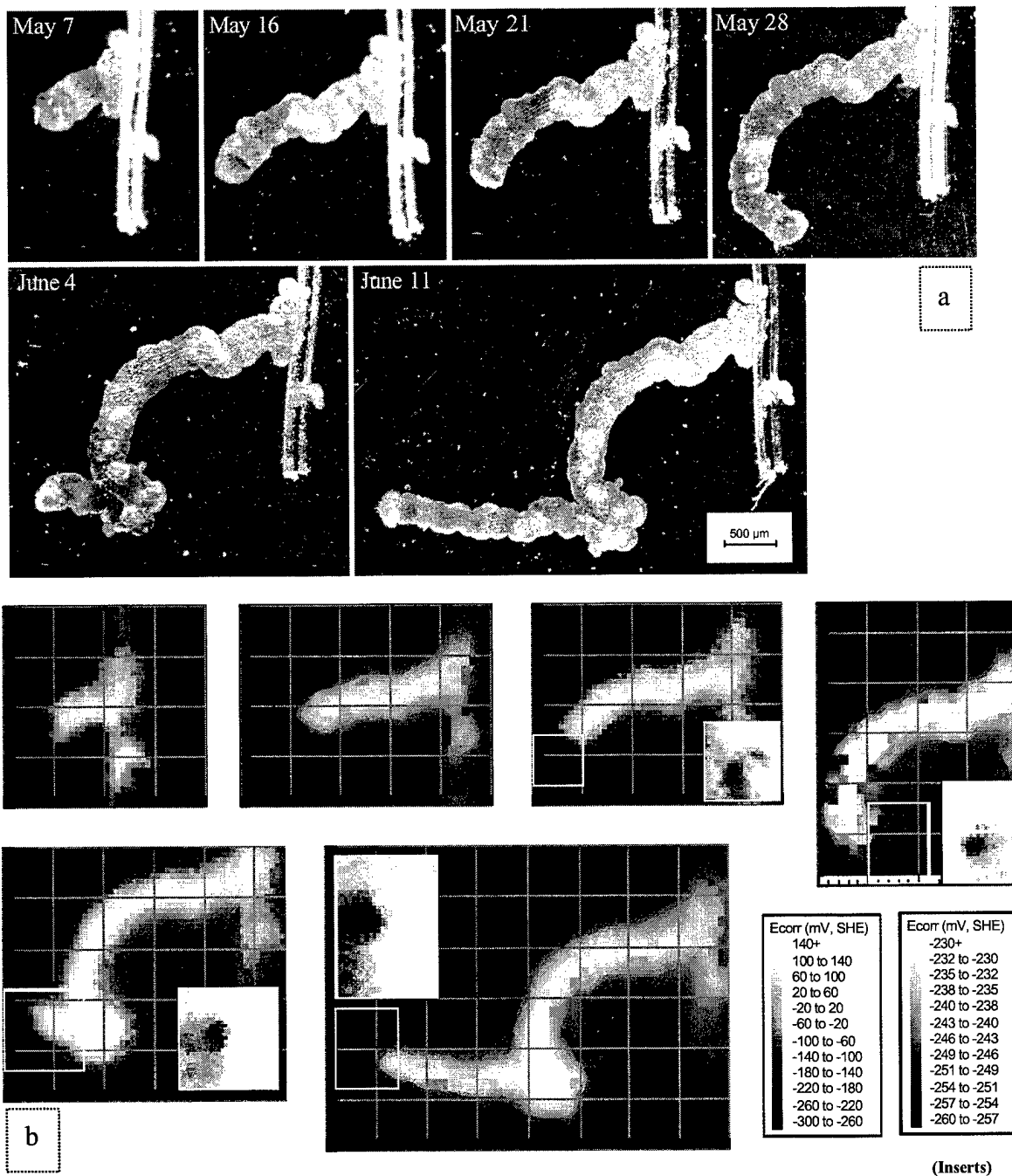

Figure 1: a) Photographs of FFC track growth on Al 2024 coated with 400 nm DCBA. b) corresponding corrosion potential distributions

Atmospheric corrosion can only persist in the presence of oxygen. Figure 2 illustrates the change in the potential maps once oxygen was eliminated from the atmosphere. The potential decreased over the whole interface after the exchange of the atmosphere from air to nitrogen gas. The intact area around the FFC track changed only slightly, the track itself showed dramatic changes, so the shape of the track became clearly visible from the potential distribution. The characteristic two-plateau potential hollow at the active head vanished in the nitrogen atmosphere indicating that the corrosion process had stopped. This clearly illustrates the marked difference in the surface activity between the actively corroding FFC filament and the unaffected regions surrounding the filament. Those reactive surfaces, which were exposed by filiform corrosion, experienced an immediate change in the presence of nitrogen from oxygen reducing sites to inactive ones. The reason for the differences in corrosion potentials along the tail cannot be explained satisfactory yet, but the different degrees of hydration and chloride concentration probably play major roles.

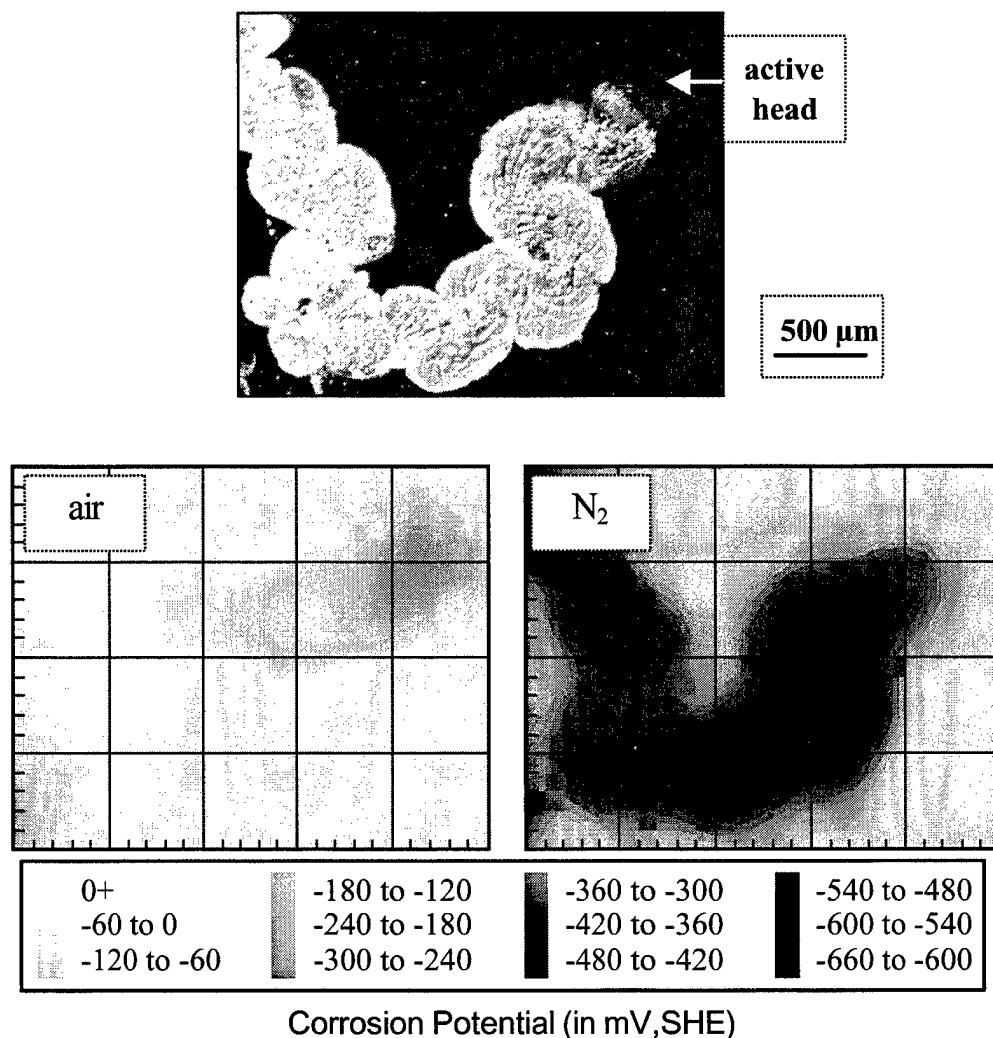

Figure 2: SKP measurements during an atmosphere change from air to N₂ of a FFC track on AA2024-T3, 50 μm epoxy-amine. Top: Photograph of the track.

5.6.3 Development of Al-Cu Model Samples

5.6.3.1 *Sample preparation*

By using photolithography (mask, photoresist coating, etc.), a pattern was deposited on polished aluminum samples (99.999%). The mask used contained 53 different arrays of squares. The size of the squares (5, 10 and 50 μm) and the horizontal and vertical spacing between the squares (5 to 200 μm) were varied. After the patterns were created on the samples, copper was deposited (thickness 200-300 nm) using physical vapor deposition. AES profiling through one of the Cu dots revealed the presence of an oxide coating between the Al substrate and the Cu dots.

Filiform corrosion was initiated by placing CaCl_2 crystals within the Cu dot regions of the model samples and then coating with a thin polyurethane acrylate coating (~500 nm). Samples were stored as previously mentioned.

5.6.3.2 *Scanning Kelvin Probe Force Microscopy Investigations*

Different types of corrosion resulted from this treatment, included FFC filaments that grew outside of the Cu region and blister-like corrosion. Why the FFC filaments do not always continue along the Cu regions is not yet clear which leads to the assumption that more than one parameter is responsible for FFC.

Figures 3-5 highlight some of the in-situ SKPFM scans which best show the behavior of the copper dots under corrosion conditions. In Figure 3, what appeared to be a FFC head encompassed four Cu dots. The potential image of Fig. 3 illustrates a dark, anodic head on the edge of two Cu dots, which have a similarly negative potential in comparison with a bright cathodic tail including two Cu dots of the same potential.

Similar to Fig. 3, Figure 4 illustrates a potential FFC head that has just approached two Cu dots, which were thereby activated and demonstrated a more negative potential. The two Cu dots found outside the corroded area maintained a positive potential to the Al surface as expected. A clear anodic FFC head is not recognizable in this image, since this head was just outside of the scanned area (seen in subsequent scans).

Once corrosion had passed over a certain area, the Cu dots lost their well-defined square structure. This is seen in Figure 5 and was confirmed by optical microscopy (Figure 6). The potential image of Figure 5 suggests that the Cu dots may have been partially broken away during the aggressive corrosion attack, but then were immediately redeposited due to the negative potential of the Al substrate (see dotted lines in the potential image of Fig. 5). The potential of all Cu dots within the corroded region remained positive to the substrate surface.

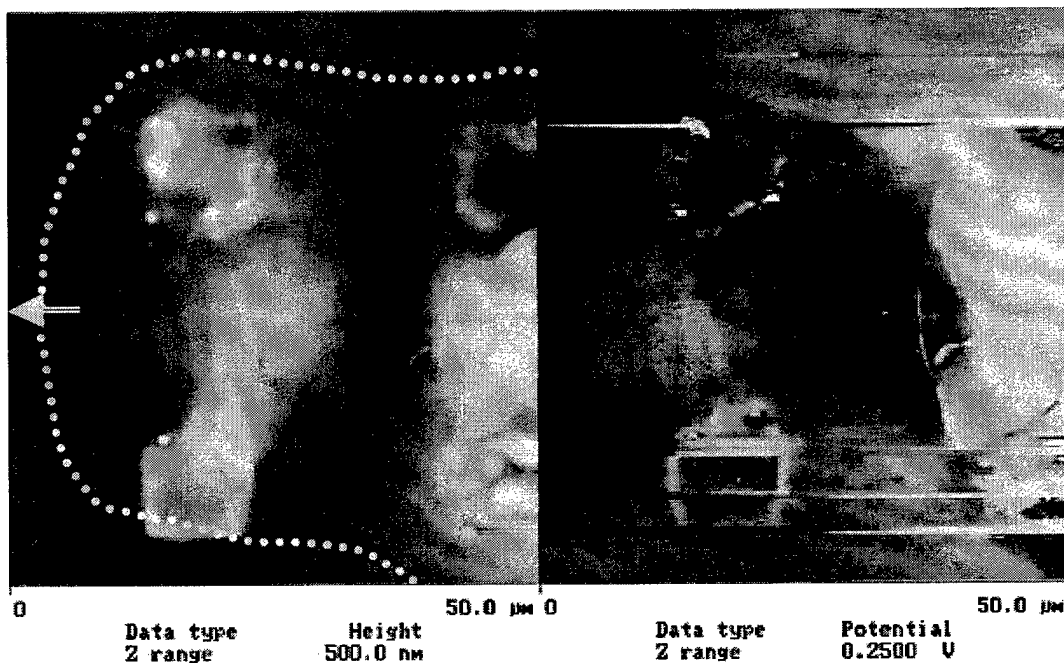

Figure 3: In-situ SKPFM analysis of a possible FFC head on a model sample (left – topography; right – potential distribution; corrosion direction is proceeding towards the left-hand side of the image)

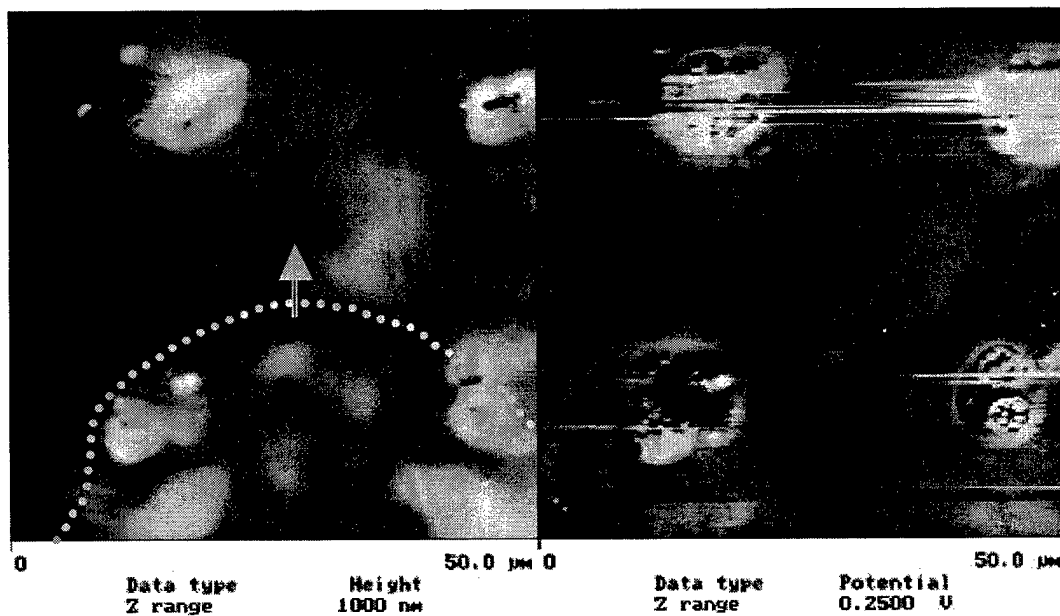

Figure 4: In-situ SKPFM analysis of a possible FFC head on a model sample (left-topography, right-potential distribution; corrosion direction is proceeding towards the top of the image)

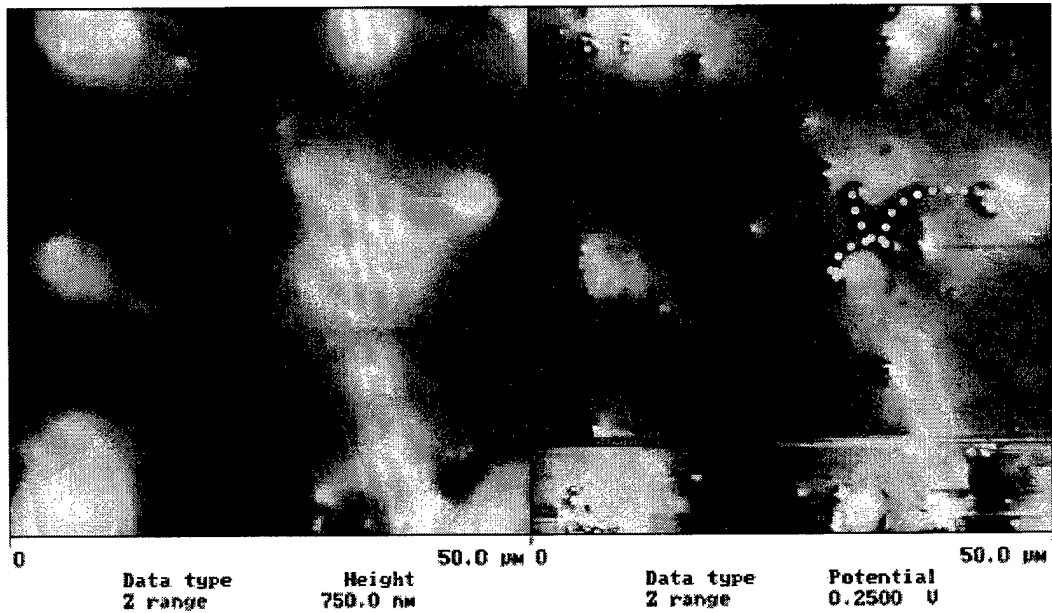

Figure 5: In-situ SKPFM analysis of a corroded region on a model sample (left – topography, right – potential distribution)

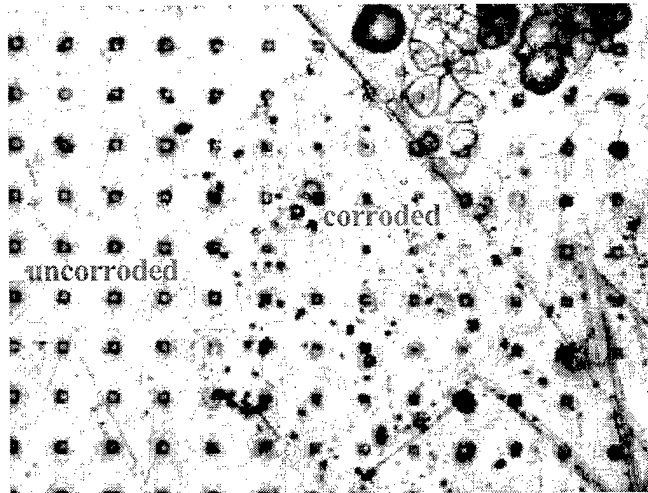

Figure 6: Optical image of corrosion, SKPFM scans of Figure 5 taken from within corroded region in this image

5.7 Technical Summary of the Group at Lehigh/Florida Atlantic University

Electrochemical impedance, adhesion and positron free-volume studies were undertaken to detail the role of chromate in a protective coating system.

5.7.1 Electrochemical Impedance Spectroscopy – Static Immersion Studies.

The goal of this study was to use electrochemical impedance spectroscopy (EIS) to study the effects of environmental exposure on the protective chromate system for aerospace service, the role of chromate in the conversion coating and in the paint. EIS was employed to investigate an epoxy coating on a CCC Al 2024-T3 panel, with and without inhibitor pigment (SrCrO_4) and to investigate a commercial paint, supplied by Deft, Inc., Irvine, CA, on CCC Al 2024-T3 panels. EIS is a valuable technique for the characterization of organic coatings on metal substrates. The technique can extract mechanistic information about coating/metal interface phenomena from the impedance spectrum. Easily extracted low-frequency impedance values (Z_{if}) measure barrier and transport properties for coated aluminum exposed to corrosive solutions. For example, an impedance value of 10^{10} ohm-cm² measured at low frequency is expected to indicate a good protective coating. Of particular interest was to determine the mechanisms by which chromate enables good protective coating properties. This determination was pursued by fabrication of specimens designed to test specific modes by which chromate functions in protective coatings. Variation of chromate location within the coating system, substrate preparation, coating types and environmental factors allowed the mechanism of chromate inhibition in protective organic coating systems to be detailed.

EIS measurements were made on four different systems of epoxy coated on CCC panels. The specimens were coated with 1) Resin 828 (low permeability), 2) Resin 736 (high permeability), 3) a mixture 50-50 of Resins 828 and 736 (medium permeability), and 4) Deft (commercial) paint. The coatings 1 - 3i were also admixed with inhibitor (5% SrCrO_4). A hole defect was made in specific samples (800 μm -diameter hole to metal substrate) using a flat ended milling tool. Four electrolyte systems were used: 1) K_2SO_4 , 2) $\text{KCl} + \text{K}_2\text{SO}_4$, 3) $\text{K}_2\text{SO}_4 + \text{SrCrO}_4$, and 4) $\text{KCl} + \text{K}_2\text{SO}_4 + \text{SrCrO}_4$.

Details of the corrosion inhibition mechanism of chromate in polymer coatings were resolved by study of sets of specimens with intentional defects, differing polymeric properties and control of the inhibitor locations. EIS is capable of monitoring the progress of the corrosion process, particularly for specimens with defects. Achieving adequate inhibition by chromate was observed to varied in time from immediate (minutes) to over a year. The inhibition mechanism was consistent with transport and reaction of chromate to form a protective film as detailed by McCreery, Frankel and other members of the MURI team.

Key findings: i) Chromate enhanced protective properties of even moderately good barrier coatings in the absence of obvious physical defects. ii) In quiescent aqueous environments, coatings with significant physical defects were inhibited by chromate more slowly in the

presence of chloride. iii) A topcoat enhanced the chromate inhibition by restricting transport of chromate away from a physical defect. iv) Cyclic exposure conditions that include a drying interval may enhance chromate inhibition by increasing the chromate concentration during the dry cycle—The effect decreases the total amount of soluble chromate necessary for inhibition.

5.7.2 Electrochemical Impedance Spectroscopy – Cyclic Exposure Studies.

EIS was used to study the effects of environmental exposure on the protective chromate system, the role of chromate in the conversion coating and chromate in the paint. This study extends the investigation using static exposure conditions and to cyclic exposure conditions. In particular, EIS was employed to investigate an epoxy coating on CCC Al 2024-T3 panels, with and without inhibitor (SrCrO_4) and with or without surface treatments.

Two types of cyclic exposures were performed for durations of 60 cycles using a Caron Environmental Chamber, Model 6030. The first cyclic exposure (with no salt dip) consisted of exposing specimens to 6 h at 50°C and 100% relative humidity (RH), wet phase, followed by 18 h at 60°C and 50% RH, dry phase. Cycling was performed on a 5 cycles/week schedule, keeping the chamber at the dry phase settings over the weekends. EIS scans were performed several times throughout the exposure, immersing the panels in distilled water for 1 h prior to starting the measurements. Specimens with intentional defects generally exhibited increases in impedance values with time. Specimens without defects showed little change in impedance over time. The presence of a topcoat did not produce any discernible differences in the impedance spectra. The second cyclic exposure (with salt dip) incorporated a 15 min salt dip after the 6 h at 100% RH, which resulted in 17.75 h at 50%RH. The salt solution used was composed of sodium chloride, calcium chloride, and sodium carbonate in the following weight percent ratios: 0.5% NaCl, 0.1% CaCl_2 , 0.075% NaHCO_3 . Additionally, this exposure was performed on a 7 cycles/week schedule. Initial and final impedance scans were performed as well as adhesion tests.

From the impedance data no detectable change in impedance occurred during the cyclic exposures. Differences were observed in the adhesion behaviors as described in the subsequent section.

5.7.3 Adhesion Studies – Cyclic Exposure

The goal of this study is to determine the effects of environmental exposure and the role of chromate in protective coating system adhesion. The approach is to determine the adhesion mechanisms by which chromate enables good protective organic coating properties. This goal is pursued by fabrication of specimens as described in the previous section and exposure to the same cyclic conditions. Variation of chromate location within the coating system, substrate preparation, coating types and environmental factors allowed for detailing the mechanism of chromate inhibition in protective organic coatings systems.

ASTM Standard Method D 3359 (crosscut tape test) was followed to evaluate the adhesive performance of the coatings. Adhesion results showed that specimens that did not contain

pigmentation actually performed better those with pigmentation. These results agree with previous testing (described in the following section) that showed specimens exposed to 150°F temperature performed better when no pigmentation was present. The adhesion loss was greater in the case of the distilled water immersion versus the cyclic test. This greater loss may be attributed to the absence of osmotic material (salts). Exposure to lower salt environments enhances osmotic water build up at the substrate/coating interface leading to greater wet adhesion loss in specimens with soluble chromate (CCC and/or pigment).

As a secondary study, infrared spectroscopy was performed using a Midac 2000 infrared spectrometer with a horizontal ATR accessory. The infrared analysis showed a change in the absorbance spectra had occurred after exposure. The natures of these changes are still under investigation. However, a comparison of the changes between coatings with and without chromate pigmentation showed very little difference.

The key finding in this study was that pigment solubility parameters affecting the osmotic pressure in a protective coating can have a strong influence on the adhesion of the coating. There is support for the selection of an inhibitor that has sufficient solubility for effective inhibition without causing osmotic blistering or severe osmotic adhesion losses.

5.7.4 Adhesion Studies – Static Exposure

Adhesion tests such as the microindentation test and the tape test were used for measuring the adhesion properties of polymer coatings on chromate converted 2024 T3 Al substrates.

Three different types of chromate conversion coatings with lower, medium (normal), and high chromate concentrations on aluminum substrates were studied. These substrates were also coated with epoxies to further protect the surfaces. Some epoxy coatings contained strontium chromate. After subjecting the substrates to water immersion tests at room temperature or higher temperature, all coatings with strontium chromate had much better adhesion properties when compared to those without. In most cases, the chromate conversion coatings with medium chromate weight were better than those with low or high chromate weight and those without chromate pretreatment.

It was also observed that the adhesion increased after a certain period of exposure in most cases. Also, the roughness or surface morphology was different in each kind of substrate: There was no direct relationship found in the adhesion data. It indicated that mechanical interlocking was not the main factor affecting the adhesion strength in our experiments.

Key findings: 1) An indentation-induced debonding test can be used to determine the adhesive strength of polymer coating/substrate. The adhesion measurements are reproducible and simple. The test appears acceptable in establishing trends in the adherence of a given coating/substrate system and in comparing adherence between different coating/substrate combination. 2) From the SEM images and the dry indentation test data, we suggest that mechanical interlocking is not the main factor affecting the adhesion strength in our experiments. 3) The strontium chromate

mixed within the polymeric top coating certainly improved adhesion properties, which were seen from the results of tape and indentation tests in room temperature or 150°F immersion. 4) The tape test was good as a semi-quantitative determination that the coating adhesion was adequate. However, it was unable to distinguish between coatings at higher levels of adhesion. 5) In most cases, the adhesion of polymeric coatings on MCCC (normal) substrates had the best overall properties and the non-chromated and HCCC substrates were the poorest. All of these samples seem to increase their adhesion after a certain period of exposure following an initial decrease.

5.7.5 PALS

PALS is used as a probe of the free volume characteristics of material structures. Infusion and interaction of species through protective coatings are first steps in material degradation. Observing the changes and detailing the protective coating behaviors from the viewpoint of non-invasive measurement of free volume properties provides useful information which is not likely obtainable by other methods. A series of studies were undertaken to develop, adapt and use this method to understand better the role of chromate in paint on aluminum aerospace alloys.

5.7.5.1 PALS Study 1. Water/Void Interactions with Chromate Pigment

Positron Annihilation Lifetime Spectroscopy (PALS) was used to measure the free volume cavity sizes and free volume fractions before and after saturation with liquid water for two epoxy coatings that exhibited different degrees of protection as measured by EIS. Different relationships were found between the equilibrium volume fraction of water absorbed and the dry relative free volume fraction of the two coatings. It was determined that water expanded the free volume cavities of the less-protective polymer, creating additional volume (pathways) and allowing easy migration of water to the coating-metal interface. PALS results suggest that concentration and oxidation-reduction effects due to chromium species can be observed directly in the nanostructure of protective polymer coatings materials. For example, intermediate lifetimes of 0.8-0.9 ns were found in specimens containing chromate (Epoxy G + SrCrO₄, 1% and 5%). These lifetimes were related to interfacial space between the epoxy matrix and SrCrO₄ particles. The free volume cavity sizes increased after exposure to SO₂.

5.7.5.2 PALS Study 2. Chromate Pigment Interfacial Voids

The purpose was to investigate the change in the structure and properties of the polymer coating / CCC system as interactions took place with reactants. One part of this study was to observe the behavior of chromium ions with polymer free volume using positron annihilation lifetime spectroscopy (PALS). In this study, we demonstrated that the method of continuous analysis of lifetime spectra helped to distinguish two different types of annihilation and trapping by determining the fraction of positron annihilation at the interface of the inorganic pigment (SrCrO₄)/organic epoxy and the thin film epoxy/substrate. To find the lifetime distributions (correlated with free volume cavities) in different materials such as organic polymers and inorganic composites, the following samples were evaluated in this study: i) Aluminum substrate (alloy 2024-T3). ii) Alloy 2024-T3 with CCC treatment. iii) Kapton material (polyimide, Dow

Chemical Corp.). iv). A composite of SrCrO₄ pigment in epoxy. v) Epoxy 828 cured with Epon 3141 polyamide.

PALS spectra were analyzed using POSITRONFIT and CONTIN programs. One to five lifetime distributions were found by CONTIN. To simplify discussion, the lifetime axes were divided into five regions. i) Region one, 0.05 - 0.15 ns, is related to p-Ps annihilation region and positron free annihilation in single crystal metals such as Cu and Ni. The average lifetime of 0.075 ns was related to p-Ps self-annihilation. No significant structural information is associated with this shortest lifetime. ii) The second region is related to free annihilation of positrons with valence electrons in reductant/oxidant materials or core electrons in metals. The lifetime distributions of Al, chromium conversion coating (CCC) and SrCrO₄ were observed in this region from 0.15 - 0.25 ns. A shift in the lifetime distribution for the Al was found with CCC. The positron free annihilation in SrCrO₄ powder gives one lifetime distribution, with the distribution shifted toward the higher lifetime region (0.25 ns). iii) The third region is related to Kapton, a polymer with a single lifetime. A single lifetime distribution with an average lifetime of 0.38 ns was observed. The single lifetime was due to free annihilation of positrons, and this established a range of 0.25 - 0.5 ns for free positron annihilation in organic or polymer material with an amorphous structure. iv) The fourth region is a short lifetime region for o-Ps formation and annihilation, 0.5 - 1.5 ns, corresponding to the interfacial molecular space between pigment particles and polymer resin. v) The fifth region is the long lifetime region for o-Ps formation and annihilation, > 1.5 ns, corresponding to larger cavities within the bulk polymer phase.

Annihilation of positrons in the chromate pigment was differentiated from that in the polymer. Furthermore, annihilation of o-Ps in the bulk polymer was differentiated from that of the interface between the chromate pigment and the polymer. These findings enable non-invasive evaluation of these phases as a function of environmental exposure or corrosion behavior.

5.7.5.3 PALS Study 3. Chromate Pigment Electrolyte Interactions

In this study, the response of these interfacial regions to electrolyte exposure is evaluated with PALS. Lifetime distributions of free volume cavities were determined, before and after exposure to 0.02M K₂SO₄ with 0.002M KCl in the following samples. i) A polymer/inhibitor composite of SrCrO₄ pigment in Epoxy 828/Epon 3141 (no Al substrate) and ii) AA2024-T3 coated with approximately 45 mg/ft² chromate conversion coating and 83 μm of Epoxy 828/Epon 3141.

PALS was performed on the specimens. The spectra were analyzed using POSITRONFIT and CONTIN programs. After exposure to the electrolyte, the interfacial free volume distribution centered at approximately 20 Å³ vanished. This change is attributed to the filling of interfacial free volume with water or ions. Ions diffuse through polymer much more slowly than do water molecules. The complete disappearance of the distribution centered at 20 Å³ suggests that water diffused to the interface and solvated Cr(VI) in the interfacial free volume, which resulted in fast o-Ps annihilation. The alternative explanation is water filling the interfacial free volume, which

should result in a significant decrease of the distribution but not necessarily its disappearance. A similar change is observed for specimens of epoxy on the CCC panels. In this case, the disappearance of the distribution is attributed to water solvating Cr(VI) ions in the chrome conversion coating, which helps transport the ions to interfacial free volume sites where rapid o-Ps annihilation occurs. Non-invasive evaluation of a chromate inhibited polymer system has been demonstrated for exposure to corrosive electrolyte.

5.7.5.4 PALS Study 4. Chromate Pigment Concentration Effects on Voids

In this study, measurements were made on epoxy specimens containing different ratios of SrCrO₄ to determine navovoid interfacial changes as a function of inhibitor loading. Also, data analysis methods were modeled to explore the resolution capabilities of the PALS technique.

The detailed studies of chromate pigment in epoxy indicated a strong relationship of structural properties to corrosion protection that may be unique to the pigment. Free volume decreased 30% linearly with pigment concentration (0-33%), which creates a coating with fewer voids for ion transport. Systematic evaluations of PALS measurements and data analysis methods relevant to chromate/polymer studies have been performed and indicate: i) The CONTIN routine is more sensitive than POSITRONFIT routine and provides more consistent results. ii) Lower regulation options in the CONTIN routine should be used for reasonable results. iii) Lifetime distribution was more reliable and related to actual positron annihilation lifetime.

5.7.5.5 PALS Study 5. Chromate Pigment and Ion Interactions with Voids

In this study, the PALS sensitivity to free volume interaction with diffusing ions was evaluated. PALS measurements were performed on Al 2024, CCC-treated and coated with Deft paint. The sample was exposed in K₂SO₄+KCl+SrCrO₄ for three years then EIS and PALS were measured in the exposure area and in an adjacent area that was not exposed to electrolyte.

The PALS spectra were analyzed by CONTIN and PALS 1000 programs specifying three and four lifetimes for the unexposed area and to three lifetimes for the exposed area. The interfacial free volume was obtained by CONTIN analysis of the PALS spectrum for epoxy and pigment mixture, as well as for the DEFT paint on CCC Al panel. During the exposure the interfacial free volume interacted with ions diffusing through the coating to the interface. The positrons (ortho-positronium) localized at the interface interacted with ions that had filled the free volume during exposure and were annihilated. This result indicated that the intermediate lifetime was due to the interfacial free volume between coating and substrate, which filled due to exposure. This indicates that the ions find pathways to the interface, interact with interfacial free volume, fill the voids and become available for corrosion/passivation or other interfacial reactions.

6 Publications

6.1 Peer reviewed publications

Frankel

P. Schmutz, V. Guillaumin, S. Lillard, J. Lillard and G. S. Frankel, "Influence of Dichromate Ions on Corrosion Processes on Pure Magnesium," in preparation.

E. Akiyama, A. J. Markworth, J. K. McCoy, G. S. Frankel, L. Xia, and R. L. McCreery, "Storage and Release of Soluble Hexavalent Chromium from Chromate Conversion Coatings on Al Alloys; Kinetics of Release," submitted to *J. Electrochem. Soc.*, 11/01.

G. S. Frankel and R. L. McCreery, "Inhibition of Al Alloy Corrosion by Chromates," accepted for publication in *Interface*, 10/01.

P. Leblanc and G. S. Frankel, "A Study of Corrosion and Pitting Initiation of AA2024-T3 Using Atomic Force Microscopy" accepted for publication in *J. Electrochem. Soc.*, 11/01.

D. Lu, P. Schmutz and G. S. Frankel, "Effect Of Chromate On Open Circuit Pit Growth In Al Thin Films" accepted for publication in *Corrosion*, 9/01.

Q. Meng, T. Ramgopal and G. S. Frankel, "The Influence of Inhibitor Ions on Dissolution Kinetics of Al and Mg Using Artificial Crevice Technique," accepted for publication in *Electrochem. Solid-State Lett.*, 11/01.

J. Zhao, L. Xia, A. Sehgal, D. Lu, R. L. McCreery, and G. S. Frankel, "Effects of Chromate and Chromate Conversion Coatings on Corrosion of AA2024-T3," *Surface and Coatings Technology*, **140**, 51-57 (2001).

V. Guillaumin, P. Schmutz, and G. S. Frankel, "Characterization of Corrosion Interfaces by the Scanning Kelvin Probe Force Microscopy Technique" *J. Electrochem. Soc.*, **148**, B163-173 (2001).

L. Xia, E. Akiyama, G. S. Frankel, and R. L. McCreery, "Storage and Release of Soluble Hexavalent Chromium from Chromate Conversion Coatings: Equilibrium Aspects of Cr^{VI} Concentration," *J. Electrochem. Soc.*, **147**, 2556 (2000).

D. Devecchio, P. Schmutz, and G. S. Frankel, "In situ AFM Scratching as an Analog to Metal CMP," *Electrochem. Solid-State Lett.*, **3** 90 (2000).

P. Schmutz and G. S. Frankel, "Influence of Dichromate Ions on Corrosion of Pure Aluminum and AA2024-T3 in NaCl Solution Studied by AFM Scratching," *J. Electrochem. Soc.*, **146**, 4461 (1999).

E. Akiyama and G. S. Frankel, "The Influence of Dichromate Ions on Al Dissolution Kinetics in Artificial Crevice Electrode Cells," *J. Electrochem. Soc.*, **146**, 4095 (1999).

A. Sehgal, D. Lu, and G.S. Frankel, "Pitting in Aluminum Thin Films; Supersaturation and Effects of Dichromate Ions," *J. Electrochem. Soc.*, **145**, 2834 (1998).

J. Zhao, G. S. Frankel, and R. L. McCreery, "Corrosion Protection of Untreated AA2024-T3 in Chloride Solution by Chromate Conversion Coating Monitored with Raman Spectroscopy", *J. Electrochem. Soc.*, **145**, 2258 (1998).

P. Schmutz and G. S. Frankel, "Characterization of AA 2024-T3 by Scanning Kelvin Probe Force Microscopy", *J. Electrochem. Soc.*, **145**, 2285 (1998).

P. Schmutz and G. S. Frankel, "Corrosion Study of AA2024-T3 by Scanning Kelvin Probe Force Microscopy and *In Situ* AFM Scratching", *J. Electrochem. Soc.*, **145**, 2295 (1998).

G. S. Frankel, "Pitting Corrosion of Metals; A Review of the Critical Factors," *J. Electrochem. Soc.*, **145**, 2186 (1998).

McCreery

W. J. Clark and R. L. McCreery, "Inhibition of Corrosion-related Reduction Processes via Chromium Monolayer Formation," submitted to *J. Electrochem. Soc.*, 9/01

W. J. Clark, J. D. Ramsey, R. L. McCreery, G. S. Frankel, "A Galvanic Corrosion Approach to Investigating Chromate Effects on Aluminum Alloy 2024-T3," submitted to *J. Electrochem. Soc.*, 4/01.

J. Ramsey, L. Xia, M. Kendig, R. McCreery, "Raman spectroscopic Analysis of the Speciation of Dilute Chromate Solutions", *Corr. Sci.*, 43(8), 1557 (2001).

L. Xia, E. Akiyama, G. S. Frankel, and R. L. McCreery, "Storage and Release of Soluble Hexavalent Chromium from Chromate Conversion Coatings: Equilibrium Aspects of Cr^{VI} Concentration," *J. Electrochem. Soc.*, **147**, 2556 (2000).

W. R. McGovern, P. Schmutz, R. G. Buchheit, and R. L. McCreery, *J. Electrochem. Soc.*, **147**, 4494 (2000).

L. Xia and R. L. McCreery, "Structure and function of ferricyanide in the formation of chromate conversion coatings on aluminum aircraft alloy," *J. Electrochem. Soc.*, **146**, 3696 (1999).

J. D. Ramsey and R. L. McCreery, "In situ Raman microscopy of chromate effects on corrosion pits in aluminum alloy," *J. Electrochem. Soc.*, **146**, 4076 (1999).

L. Xia and R. L. McCreery, "Chemistry of a chromate conversion coating on aluminum alloy AA2024-T3 probed by vibrational spectroscopy," *J. Electrochem. Soc.*, **145**, 3083 (1998).

J. Zhao, G. S. Frankel, and R. L. McCreery, "Corrosion Protection of Untreated AA2024-T3 in Chloride Solution by Chromate Conversion Coating Monitored with Raman Spectroscopy", *J. Electrochem. Soc.*, **145**, 2258 (1998).

Isaacs

Chromate in conversion coatings: A XANES study of its concentration and mobility. C. S. Jeffcoate, H. S. Isaacs, A. J. Aldykiewicz, Jr., and M. P. Ryan. *J. Electrochem. Soc.*, 147(2), 540-47 (2000).

H. S. Isaacs, G. Adzic, C. S. Jeffcoate, "Visualizing Corrosion", *Corrosion*, **56**, 971 (2000).

H. Lee, F. Xu, C. S. Jeffcoate, and H. S. Isaacs, "Cyclic Polarization Behavior of Aluminum Oxide Films in Near Neutral Solutions," *Electrochem. Solid-State Lett.*, **4**, B31 (2001).

Kendig

M. Kendig, D. Hardwick, and M. Cunningham, "Role of Corrosion Inhibiting Pigments on the Electrochemical Kinetics of a Copper -Containing Aluminum Alloy," submitted to *J. Electrochem. Soc.*

J. Waldrop and M. Kendig, "Nucleation of Chromate Conversion Coating on Aluminum 2024-T3 Investigated by Atomic Force Microscopy," *J. Electrochem. Soc.*, 145(1), L11 (1998).

M. Kendig, R. Addison, S. Jeanjaquet, "The Influence of Oxo-Cr(VI) Species on the Zeta Potential in the Porous Oxide of Anodized Aluminum", *J. Electrochem. Soc.*, 146(12), 4419 (1999).

M. Kendig, R. Addison, S. Jeanjaquet, "Adsorption of Ce(III) on Anodized Al", *Electrochemical and Solid State Letters*, 3(6), 266-267 (2000).

M. Kendig, S. Jeanjaquet, R. Addison and J. Waldrop, "Role of Hexavalent Chromium in the Inhibition of Corrosion of Aluminum Alloys", *Surf. Coat. Tech.*, 140(1), 58 (2001).

J. Ramsey, L. Xia, M. Kendig, R. McCreery, "Raman spectroscopic Analysis of the Speciation of Dilute Chromate Solutions", *Corr. Sci.*, 43(8), 1557 (2001).

M. Kendig and S. Jeanjaquet "Cr(VI) and Ce(III) Inhibition of Oxygen Reduction on Copper", in revision, submitted to *J. Electrochem. Soc.* (2001).

Clayton

- C. R. Clayton and G. P. Halada, "The Application of Laboratory and Synchrotron-based Spectroscopic Techniques to the Study of Passive Films and Corrosion Protective Layers", *Zairyo-To-Kankyo (Corrosion Engineering)*, **50**, 364-372, (2001).
- S. V. Kagwade, C. R. Clayton, D. Chidambaram, M. L. Du, and F. P. Chiang, "The Influence of Acetone Degreasing on the Corrosion Behavior of AA2024-T3", *J. Electrochem. Soc.*, **147**, 4125-4130 (2000)
- S. V. Kagwade, C. R. Clayton, D. Chidambaram and G. P. Halada, "Photochemical Breakdown of Acetone on Copper", *Electrochim. Acta*, **46**, 2337-2342 (2001).
- S. V. Kagwade, C. R. Clayton and G. P. Halada, "Causes and prevention of photochemical reduction of hexavalent chromium during x-ray photoelectron spectroscopy", *Surf. Interface Anal.*, **31**, 442-447 (2001).
- D. Chidambaram and G. P. Halada, "Infrared Microspectroscopic Studies on the Pitting of AA2024-T3 Induced by Acetone Degreasing", *Surf. Interface Anal.*, **31**, 1056-1059 (2001).
- D. Chidambaram, G. P. Halada and C. R. Clayton, "Development of a Technique to Prevent Radiation Damage of Chromate Conversion Coatings During X-Ray Photoelectron Spectroscopic Analysis", *App. Surf. Sci.*, **181**, 283-295 (2001).
- M. Vasquez, G. P. Halada, C. R. Clayton and J. P. Longtin, "Study of Chromate Conversion Coatings Formed on AA2024-T3 and Thin Film Analogs of Intermetallic Constituents", submitted to *J. Electrochem. Soc.* (2001).
- M. Vasquez, J. R. Kearns, G. P. Halada and C. R. Clayton, "Synchrotron Infrared Microspectroscopy of Chromate Conversion Coated Interfaces", submitted to *Surf. Interface Anal.*, (2001).
- M. Vasquez, J. R. Kearns, G. P. Halada and C. R. Clayton, "Spatially Resolved Microchemical Analysis of Chromate Conversion Coated AA2024-T3", submitted to *Surf. Interface Anal.*, (2001).
- M. Vasquez, G. P. Halada and C. R. Clayton, "Application of Synchrotron Spectroscopic Techniques to the Study of Protective Corrosion Layers", Submitted to *Electrochim. Acta* (2001). *Review paper.*

Stratmann

W. Schmidt; M. Stratmann, "Scanning Kelvinprobe Investigations of Filiform Corrosion on Aluminum Alloy 2024-T3," *Corr. Sci.*, **40**, 1141, 1998.

G. Grundmeier; W. Schmidt; M. Stratmann, „Corrosion protection by organic coatings: electrochemical mechanism and novel methods of investigation,“ *Electrochimica Acta*, **45**, No. 15/16, 2515, 2000.

J. Vander Kloet; M. Stratmann; A.W. Hassel, “Characterization of Pretreated Aluminum Alloy 2024-T3,” in preparation.

J. Vander Kloet; W. Schmidt; M. Stratmann; A.W. Hassel “The Role of Chromate in Filiform Corrosion Inhibition,” in preparation.

6.2 Publications in conference proceedings

Frankel

Y. Baek and G. S. Frankel, "Electrochemical Quartz Crystal Microbalance Study of Corrosion of Phases in AA2024-T3," in *Corrosion and Corrosion Protection*, J. D. Sinclair, E. Kalman, M. W. Kendig, W. Plieth, and W. H. Smyrl, eds, PV 2001- 22, The ECS Proceedings Series, Pennington, NJ (2001).

P. Leblanc, V. Laget and G. S. Frankel, "Corrosion Studies of AA2024-T3 Using Scanning Kelvin Probe Force Microscopy," in *State of the Art Application of Surface and Interface Analysis Methods to Environmental Material Interactions, in Honor of James E. Castle's 65th Year*, D.R. Baer, C.R. Clayton, G.P. Halada, and G.D. Davis, Eds, PV 2001-01, The ECS Proceedings Series, Pennington, NJ (2001).

G. S. Frankel and P. Leblanc, "Studies of Corrosion using Scanning Kelvin Probe Force Microscopy and AFM Scratching," Proceedings of 12th Asia Pacific Corrosion Control Conference, Seoul, 10/01.

G. S. Frankel, "Localized Corrosion of Metals; A Review of the Rate-Controlling Factors in Initiation and Growth," in *Passivity of Metals and Semiconductors*, M. B. Ives, J. L. Luo, and J. R. Rodda, eds., The Electrochemical Society Proceedings Volume 99-42, p. 445 (2001).

P. Schmutz and G. S. Frankel, "Characterization of Potential Inhomogeneities on Passive Surfaces by Scanning Kelvin Probe Force Microscopy," in *Passivity of Metals and Semiconductors*, M. B. Ives, J. L. Luo, and J. R. Rodda, eds., The Electrochemical Society Proceedings Volume 99-42, p. 537 (2001).

G. Frankel, "Techniques for Assessment of Localized Corrosion," in *Localized Corrosion*, G. S. Frankel and J. R. Scully, eds., Proceedings of NACE 2001 Research Topical Symposium.

D. Lu, P. Schmutz and G. S. Frankel, "Open Circuit Pit Growth In Al Thin Films," in *Second Intl. Symp. on Pits and Pores*, P. Schmuki, ed., The Electrochemical Society Proceedings Volume (2000).

V. Guillaumin, P. Schmutz and G. S. Frankel, "Scanning Kelvin Probe Force Microscopy and Auger Electron Spectroscopy Studies of Passive Surfaces," in *Localized In-Situ Methods for Investigating Electrochemical Interfaces*, A. C. Hillier, M. Seo, and S. R. Taylor, eds, The Electrochemical Society Proceedings Volume 99-28, p. 339-350, (1999).

D. Devecchio, P. Schmutz, and G. S. Frankel, "A New Approach for the Study of Chemical Mechanical Polishing," in *Third International Symposium on Chemical Mechanical Polishing in IC Device Manufacturing*, Y. A. Arimoto, R. L. Opila, C. Reidsema Simpson, K. B. Sundaram and Y. Homma, eds, The Electrochemical Society Proceedings Volume 99-37, p. 293-300, (1999).

E. Akiyama, L. Xia, R. McCreery, A. Markworth, and G. S. Frankel, "Release of Chromate Ions from Chromate Conversion Coatings on Al Alloys," in *International Symposium in Honor of Professor Norio Sato: Passivity and Localized Corrosion*, R. G. Kelly, B. MacDougall, M. Seo and H. Takahashi, eds, The Electrochemical Society Proceedings Volume 99-27, p 300-309, (1999).

Kendig

M. Kendig and R. Buchheit, "Corrosion Inhibition of Al and Al Alloys by Hexavalent Cr Compounds. A Mechanistic Overview", 'Surface Conversion of Aluminum and Ferrous Alloys for Corrosion Resistance', R. Buchheit, M. R. Jaworoski, P. D. Chalmer, eds., Research Topical Symposium, Corrosion/2000, NACE, Houston, TX, USA (2000).

M. Kendig, "Mechanism of Corrosion Protection of Aluminum and its Alloys by Chromate", to be published in the Proceedings of the SAMPE (2001).

M. Kendig, R. Buchheit, H. Guan, R. Leard "Electrochemical Aspects of Dealloyed Al₂CuMg" Proceedings of the Electrochemical Society, April 2001.

M. Kendig, S. Jeanjaquet and Y. Chung, "The Influence of Macroscopic Surface Area on Electrochemical Impedance of Al 2024-T3", Proceedings of the Electrochemical Society, 2001.

Isaacs

H. S. Isaacs and G. Adzic, "Kinetics of Pitting Corrosion in Gels" in *Pits and Pores II*, P. Schmuki, D. J. Lockwood, Y. H. Ogata, H. S. Isaacs, Eds., The Electrochemical Soc. Inc., Proceedings Vol. 2000-25, p. 495, 2001.

H. S. Isaacs, G. Adzic, C. Jeffcoate, and M.P. Ryan, "Scanning Volta Potentials of Metals In Irradiated Air," in *Scanning Probe Techniques for Materials Characterization at Nanometer Scales*, D. C. Hansen, H. S. Isaacs, K. Sieradzki, Eds. The Electrochemical Soc. Inc., Proceedings Vol. 2000-35, 2001.

V. Laget, C. Jeffcoate, H. S. Isaacs, and R. G. Buchheit, "Thermal Stability and Aging Characteristics of Chromate Conversion Coatings on Aluminum Alloy 2024-T3," Proc. Vol. 196th Meeting of the Electrochemical Society, Inc., Corrosion and Corrosion Control in Saltwater Environments Symp., Honolulu, Hawaii, Oct. 17-22, 1999.

H. S. Isaacs, F. Xu, and C. S. Jeffcoate, "Dissolution of oxide films on aluminum in near neutral solutions," Proc. Vol. 196th Meeting of the Electrochemical Society, Inc., Passivity and Localized Corrosion Symp., Honolulu, Hawaii, Oct., 1999.

C. S. Jeffcoate, H. S. Isaacs, J. Hawkins, G. Thompson, "The Effect of Chromate Concentration on the Repassivation of Corroding Aluminum," in *Critical Factors in Localized Corrosion III*, Fall Meeting of The Electrochemical Society, Boston, MA, (1998).

C. S. Jeffcoate and H. S. Isaacs "Chromate as an inhibitor for Aluminum," in Proceedings of Research in Progress Symposium, Corrosion '99, NACE, (1999).

C. S. Jeffcoate, M. P. Ryan, G. P. Bierwagen, and H. S. Isaacs, "Current Density Mapping of Coated Aluminum Alloys During Corrosion in Aqueous Electrolyte," Fall Meeting of The Electrochemical Society, Boston, MA, (1998).

H.S. Isaacs and A.J. Aldykiewicz, "Distribution of Chromium Species in Chromate Conversion Coatings," Abstract No. 114, The Electrochemical Society 193rd Meeting, May 3-8, 1998 - San Diego, California.

K. Sasaki, H. Isaacs, and P. Levy, "Insights into Electrochemical Noise of Aluminum in Chloride Environments" The Electrochemical Society, Meeting. San Francisco, CA, Sept 2-7, 2001

K. Sasaki, and H. Isaacs, "Investigating the Origins of Chromate Inhibition on Corrosion of Aluminum and Its Alloys by Electrochemical Noise Measurements" The Electrochemical Society, Meeting. - San Francisco, CA, Sept 2-7, 2001

K. Sasaki, H. Isaacs, C. Jeffcoate, H. Lee, and V. Srinivasamurthi, "In-situ XANES Study of Formation of Chromate Conversion Coatings on Aluminum and Its Alloys" The Electrochemical Society, Meeting. San Francisco, CA, Sept 2-7, 2001

H. Lee and H. Isaacs "Effects of Anion, pH, and Temperature on Dissolution Behavior of Aluminum Oxide Films," The Electrochemical Society, Meeting. San Francisco, CA, Sept 2-7, 2001

H. Isaacs, "In Situ Studies of Corrosion Using X-ray absorption Near Spectroscopy and Fluorescence Techniques," The Electrochemical Society, 199th Meeting, Washington, DC,

March, 2001.

H. Lee, H. Isaacs, and F. Xu, "Cyclic Polarization Behavior of Aluminum Oxide Films in Near Neutral Solutions," The Electrochemical Society, 199th Meeting, Washington, DC, March, 2001.

H. Isaacs, "In Situ Studies of Corrosion Using X-ray Absorption Near Spectroscopy and Fluorescence Techniques," The Electrochemical Society, 199th Meeting, Washington, DC, March, 2001.

H.S. Isaacs and G. Adzic, "Determination of Kinetics of Pitting Corrosion in Jells with pH Indicators," The Electrochemical Society, 198th Meeting, Phoenix, October, 2000

K. Sasaki, H. Isaacs, and P. Levy, "Insights into Electrochemical Noise of Aluminum in Chloride Environments" The Electrochemical Society, Meeting. San Francisco, CA, Sept 2-7, 2001

K. Sasaki, and H. Isaacs, "Investigating the Origins of Chromate Inhibition on Corrosion of Aluminum and Its Alloys by Electrochemical Noise Measurements" The Electrochemical Society, Meeting. - San Francisco, CA, Sept 2-7, 2001

K. Sasaki, H. Isaacs, C. Jeffcoate, H. Lee, and V. Srinivasamurthi, "In-situ XANES Study of Formation of Chromate Conversion Coatings on Aluminum and Its Alloys" The Electrochemical Society, Meeting. San Francisco, CA, Sept 2-7, 2001

H. Lee and H. Isaacs, "Effects of Anion, pH, and Temperature on Dissolution Behavior of Aluminum Oxide Films," The Electrochemical Society, Meeting. San Francisco, CA, Sept 2-7, 2001

H. Isaacs, "In Situ Studies of Corrosion Using X-ray absorption Near Spectroscopy and Fluorescence Techniques," The Electrochemical Society, 199th Meeting, Washington, DC, March, 2001.

H. Lee, H. Isaacs, and F. Xu, "Cyclic Polarization Behavior of Aluminum Oxide Films in Near Neutral Solutions," The Electrochemical Society, 199th Meeting, Washington, DC, March, 2001.

Stratmann

A. W. Hassel, J. Vander Kloet, W. Schmidt, M. Stratmann "In-situ SKP Investigation and ToF-SIMS Analysis of Filiform Corrosion on Aluminium Alloy 2024-T3," Proceedings of the Japan Society of Corrosion Engineering, Materials and Environments, 48, 2001.

M. Stratmann, J. Vander Kloet, W. Schmidt, A.W. Hassel, "Investigations into the Role of Copper in AA2024-T3 Aluminium Alloys on Filiform Corrosion Advancement and the Role of Chromium in Corrosion Inhibition," 63rd AGEF Seminar, Düsseldorf, April 20-21, 2001.

J. Vander Kloet; W. Schmidt; A.W. Hassel, M. Stratmann, "Filiform Investigations on Aluminum Alloy 2024-T3," Electrochemical Society Proceedings, San Francisco 2-7, 2001.

Clayton

S. V. Kagwade, C. R. Clayton, "The Effect of Acetone Cleaning on the Corrosion Characteristics of AA2024-T3 in a Mist of 0.5 M NaCl," in *Passivity and Its Breakdown*, P. M. Natishan, (Eds), Proceedings Volume 97-26, The Electrochemical Society, Pennington, NJ, p. 631, 1997.

G. P. Halada, C. R. Clayton, M. J. Vasquez, and J. R. Kearns, M. W. Kendig, S. L. Jeanjaquet, G. G. Peterson, G. Shea McCarthy, G. L. Carr, G. P. Williams, and L. M. Miller, "Spatially-Resolved Microchemical Analysis of Chromate Conversion Coated Aluminum Alloys and Constituent Intermetallic Particles," in *Critical Factors in Localized Corrosion III-In Honor of Jerome Kruger's 70th Birthday*, R. G. Kelly and G. S. Frankel (Eds.) Proceedings Volume 97-26, p. 300, The Electrochemical Society, Pennington, NJ (1999).

G. Halada, J. R. Kearns, C. R. Clayton, M. Vasquez, M. W. Kendig, and S. L. Jeanjaquet, "Synchrotron Infrared Microspectroscopy (SIRS) of Chromate Conversion Coatings on Aluminum-bearing Intermetallic Compounds (Beamline U4IR)," in *National Synchrotron Light Source Activity Report 1998*, National Technical Information Service, Springfield, VA, 1998.

G. Halada, J. R. Kearns, C. R. Clayton, M. W. Kendig, S. Jeanjaquet, R. D. Granata, and Grace-Shea McCarthy, "Micro XANES Study of Chromate Conversion Coating Homogeneity and Aging on AA2024-T3 (Beamline X26A)," in *National Synchrotron Light Source Activity Report 1998*, National Technical Information Service, Springfield, VA, 1998.

C. R. Clayton, G. P. Halada, and S. V. Kagwade, "Photochemical Reaction of Organics on Copper and Copper-Containing Aluminum Alloys," in *Critical Factors in Localized Corrosion III-In Honor of Jerome Kruger's 70th Birthday*, R. G. Kelly and G. S. Frankel (Eds.) Proceedings Volume 97-26, p.300, The Electrochemical Society, Pennington, NJ (1999).

C. R. Clayton, G. P. Halada, M. J. Vasquez, J. R. Kearns, D. Chidambaram, and R.D. Granata, "Hydrophobicity and Structural Stability During Aging of Chromate Conversion Coatings on Al Alloys, in *Passivity and Localized Corrosion An International Symposium-In Honor of Professor Norio Sato*, M. Seo, B.MacDougall, H. Takahashi and R.G. Kelly (Eds.) Proceedings Volume 99-27, p. 290, The Electrochemical Society, Pennington, NJ (1999).

C. R. Clayton, G. P. Halada, D. Chidambaram, and M. J. Vasquez, "On the Bipolar Mechanism for Chromate-Induced Repassivation of Active Sites on Chromate Conversion Coated Aluminum Alloys," in *Passivity and Localized Corrosion An International Symposium-In Honor of Professor Norio Sato*, M. Seo, B. MacDougall, H. Takahashi and R.G. Kelly (Eds.) Proceedings Volume 99-27, p. 249, The Electrochemical Society, Pennington, NJ (1999).

D. Chidambaram, C. R. Clayton and G. P. Halada, "On the Electrochemical Behavior of Dichromate and Molybdate Treated Intermetallic Particles Present in AA2024-T3", in *Corrosion and Corrosion Prevention of Low Density Metals and Alloys*, B.A. Shaw, R.G. Buchheit and J. P. Moran, Eds, PV 2000-23, p69, The ECS Proceedings Series, Pennington, NJ (2001).

M. J. Vasquez, G. P. Halada, C. R. Clayton and J. P. Longtin, "Composition of Surface Treated Thin Film Analogs of Intermetallic Constituents in AA2024-T3", in *Corrosion and Corrosion Prevention of Low Density Metals and Alloys*, B.A. Shaw and R.G. Buchheit, Eds, PV 2000-23, p57, The ECS Proceedings Series, Pennington, NJ (2001).

M. J. Vasquez, G. P. Halada, C. R. Clayton and J. P. Longtin, "Effects of Aging on Chromate Conversion Coatings Formed on AA2024-T3 and Some Intermetallic Constituents", in *Corrosion and Corrosion Prevention of Low Density Metals and Alloys*, B.A. Shaw and R.G. Buchheit, Eds, PV 2000-23, p101, The ECS Proceedings Series, Pennington, NJ (2001).

D. Chidambaram, C. R. Clayton, G. P. Halada and J. R. Kearns, "Effect of Surface Pretreatments on Chromate Conversion Coatings" in *State-of-the-Art Application of Surface and Interface Analysis Methods to Environmental Material, Interactions: In Honor of James E. Castle's 65th Year*, D.R. Baer, C.R. Clayton, G.P. Halada, and G.D. Davis, Eds, PV 2001-01, The ECS Proceedings Series, Pennington, NJ (2001).

M. J. Vasquez, G. P. Halada, C. R. Clayton", M. J. Vasquez, G. P. Halada and C. R. Clayton, "Studies of The Structure and Formation of Chromate Conversion Coatings on Thin Films of Copper-Containing Intermetallic Constituents in AA2024-T3", in *State-of-the-Art Application of Surface and Interface Analysis Methods to Environmental Material, Interactions: In Honor of James E. Castle's 65th Year*, D.R. Baer, C.R. Clayton, G.P. Halada, and G.D. Davis, Eds, PV 2001-01, The ECS Proceedings Series, Pennington, NJ (2001).

D. Chidambaram, C. R. Clayton and G. P. Halada, "Studies on the Repassivation Behavior of Aluminum Exposed to Dichromate Solution", in *State-of-the-Art Application of Surface and Interface Analysis Methods to Environmental Material, Interactions: In Honor of James E. Castle's 65th Year*, D.R. Baer, C.R. Clayton, G.P. Halada, and G.D. Davis, Eds, PV 2001-01, The ECS Proceedings Series, Pennington, NJ (2001).

Granata

M.M. Madani, R.M. Simmons, K.M. Mann, Y.M. Sigonney, R.R. Miron and R.D. Granata, "Chromate Inhibition of Polymer-Coated Aluminum Alloy 2024-T3," Fall (2000) Meeting of the Electrochemical Society, Phoenix, AZ, in *Corrosion And Corrosion Prevention of Low Density Metals and Alloys*, B.A. Shaw, R.G. Buchheit, J.P. Moran, eds., The Electrochemical Society, Pennington, NJ, 2001, ISBN 1566772907, pp.114-23.

M.M. Madani, R.R. Miron, R.D. Granata, "Interfacial Free Volume Measurements of Epoxy on Aluminum by PALS," *Proceedings of ANTEC'99*, Society of Plastic Engineers, New York, NY, May 3, 1999.

M.M. Madani and R.D. Granata, "Free Volume Changes in Water Containing Cr(VI) and Cr(III) Using PALS," in Positron Annihilation ICPA-11, Proceedings of the 11th International Conference on Positron Annihilation, Kansas City, Missouri, USA, May, 1997, *Materials Science Forum* Vols. 255-257, Trans Tech Publications, Uetikon-Zuerich, Switzerland, 369-71 (1997).

7 Interactions/Transitions

7.1 Participation/Presentation at Meetings, Conferences, Seminars

Frankel

G. S. Frankel, "Studies of Corrosion using Scanning Kelvin Probe Force Microscopy," 12th Asia-Pacific Corrosion Control Conference 2001, Seoul, Korea, 10/10/01, **Plenary Lecture**.

Y. Baek and G. S. Frankel, "Electrochemical Quartz Crystal Microbalance Study of Corrosion of Phases in AA2024-T3," The Electrochemical Society Fall Meeting, San Francisco, September, 2001.

G. S. Frankel, "Scanning Kelvin Probe Force Microscopy and AFM Scratching Studies of Corrosion," Departmental Colloquium Series, MSE, OSU, 5/18/01.

P. Leblanc, V. Laget and G. S. Frankel, "Corrosion Studies of AA2024-T3 Using Scanning Kelvin Probe Force Microscopy," The Electrochemical Society Spring Meeting, Washington, DC, March, 2001.

D. Lu and G. Frankel, "Open Circuit Pit Growth in Al," ECS Meeting, Phoenix, 10/26/00.

P. Schmutz, V. Guillaumin, D. Devecchio, G. S. Frankel, "Scanning Kelvin Probe Force Microscopy Studies of Corrosion," ACS Meeting, Washington, DC, 8/23/00, **Invited Talk**.

G. S. Frankel, "Activities in the Fontana Corrosion Center," Luoyang Ship Materials Research Institute, Qingdao, 8/4/00, Institute for Corrosion and Protection of Materials, Shenyang, 8/8/00, Corrosion and Protection Centre, University of Science and Technology Beijing, 8/10/00. **Invited Talk.**

P. Schmutz, V. Guillaumin, and G. S. Frankel, "Scanning Kelvin Probe Force Microscopy Studies of Passive Surfaces," MRS Meeting, San Francisco, 4/00. **Invited Talk.**

D. Devecchio, P. Schmutz, and G. S. Frankel, "A New Approach for the Study of Chemical Mechanical Polishing," 1999 ECS Fall Meeting, Honolulu, 10/21/99.

G. S. Frankel, "Localized Corrosion of Metals: A Review of the Critical Factors in Initiation and Growth," Passivity-8, Jasper, Canada, 5/99, **Keynote address.**

E. Akiyama, G. S. Frankel, L. Xia, and R. L. McCreery, "Release of Chromate Ions from Chromate Conversion Coatings," Research in Progress Symposium, NACE Corrosion99, San Antonio, 4/26/99. **Invited Talk.**

P. Schmutz, V. Guillaumin, and G. S. Frankel, "Scanning Kelvin Probe Force Microscopy Studies in Corrosion," NACE 2000, Corrosion in Progress Symposium, Orlando, 3/00. **Invited Talk.**

P. Schmutz, V. Guillaumin, and G. S. Frankel, "Scanning Kelvin Probe Force Microscopy and AES Study of Passive Alloy," 1999 ECS Fall Meeting, Honolulu, 10/21/99.

P. Schmutz, V. Guillaumin, D. DeVecchio and G. S. Frankel, "Characterization of Corrosion Processes on Passive Aluminum Surfaces by Atomic Force Microscopy Scratching," ASM meeting, Cincinnati, 11/99. **Invited Talk.**

P. Schmutz, V. Guillaumin, D. DeVecchio and G. S. Frankel, "Characterization of Corrosion Processes on AA2024-T3 Surfaces by Scanning Kelvin Probe Force Microscopy," ASM meeting, Cincinnati, 11/99. **Invited Talk.**

P. Schmutz and G. S. Frankel, "Study of Localized Corrosion of Al and Al Alloys by AFM Scratching," Research in Progress Symposium, NACE Corrosion99, San Antonio, 4/26/99. **Invited Talk.**

P. Schmutz and G. Frankel, "Characterization of Alloy AA2024-T3 by Scanning Kelvin Probe Force Microscopy," Research in Progress Symposium, NACE Corrosion 98, San Diego, 3/25/98.

G. S. Frankel, "Mechanism of Al Alloy Corrosion and the Role of Chromate Inhibitors", Cleveland section meeting of The Electrochemical Society, 12/9/98.

G. S. Frankel, P. Schmutz, E. Akiyama, W. Zhang, D. Lu, and A. Sehgal, "Effects of Chromate Ions on Localized Corrosion of Al and Al Alloys," AFRL Workshop on Advanced Metal Finishing Techniques for Aerospace Applications, Keystone, CO, 8/27/98, **Invited Talk**.

G. S. Frankel, "Scanning Kelvin Probe Force Microscopy", Aqueous Corrosion Gordon Conference, New London, NH, 7/7/98, **Invited Talk**.

P. Schmutz, A. Sehgal, and G. S. Frankel, "Effects of Chromate Ions on Pitting of AA1100-0 and AA2024-T3," ECS Spring Meeting, San Diego, 5/98.

G. Frankel, "Novel Applications of Scanning Probe Microscopy to the Study of Localized Corrosion," Penn State University Department of Engineering Science and Mechanics Colloquium, 4/8/98, **Invited Talk**.

P. Schmutz and G. S. Frankel, "Characterization of AA 2424-T3 by Scanning Kelvin Probe Force Microscopy," Research in Progress Symposium, NACE Corrosion 98, San Diego, 3/98.

G. S. Frankel, "Mechanism of Al Alloy Corrosion and the Role of Chromate Inhibitors", Special Seminar, MIT, 12/1/97.

G. S. Frankel, "Mechanism of Al Alloy Corrosion and the Role of Chromate Inhibitors", Central Michigan ECS Local Section Meeting, Midland Michigan, 10/29/97.

P. Schmutz, J. Zhang, and G. S. Frankel, "Studies of Pitting Corrosion of Al and Al Alloys", Swiss Federal Technical Institute, Zurich, Switzerland, 8/26/97.

P. Schmutz, J. Zhang, and G. S. Frankel, "Studies of Pitting Corrosion of Al and Al Alloys", Ecole Polytechnique, Lausanne, Switzerland, 8/22/97.

G. S. Frankel, "Pitting Corrosion: A Review of the Critical Factors", Spring ECS Meeting, Montreal, 5/97, **Keynote Talk**.

G.S. Frankel, "Effects Of Inhibitor Ions On The Growth Of Pits In Thin Film Aluminum," D. Lu, A. Sehgal, Fall ECS Meeting, San Antonio, 10/10/95, **Invited Talk**.

McCreery

J. D. Ramsey, R. L. McCreery, "In-situ Raman Microscopy of Chromate Effects on Corrosion Pits in Aluminum Alloy", Pittcon 99, Orlando, March 9, 1999.

L. Xia, R. L. McCreery, "Structure and Function of Ferricyanide in the Formation of Chromate Conversion Coatings on Aluminum Aircraft Alloy", Pittcon 99, Orlando, March 5, 1999.

R. L. McCreery, L. Xia, "Ferricyanide Speciation and Ferricyanide Acceleration Mechanism in Chromate Anticorrosion Coatings Probed by Vibrational Spectroscopy", Electrochemical Society National Meeting, Seattle, May 4, 1999.

R. L. McCreery, J. D. Ramsey, "In-situ Raman Microscopy of Chromate Effects on Corrosion Pits in Aluminum Alloy", Electrochemical Society National Meeting, Seattle, May 4, 1999.

R.L. McCreery, "Chemistry of Chromate Conversion Coatings on Aluminum Alloy 2024-T3: Formation, Structure Active Protection", 2000 Gordon Research Conference on Aqueous Corrosion, **Invited Talk.**

R. L. McCreery, "Formation of Chromate Conversion Coatings on Al-Cu-Mg Intermetallic Compounds and Alloys", Pittcon 2000, New Orleans.

J. Zhao, R.L. McCreery and G. S. Frankel, "Raman Spectroscopy Studies of Corrosion" ACS Meeting, Washington, DC, 8/23/00, **Invited Talk.**

J. Ramsey, R. L. McCreery, W. McGovern, R. Buchheit, "Probing the Corrosion Inhibition Mechanism of Chromium(VI) Oxides with Raman Spectroscopy", Pittcon 2000, New Orleans.

W. Clark, R. L. McCreery, "Oxygen Reduction Inhibition by Chromate and Organic Films on Aluminum Aircraft Alloy", Pittcon 2001, New Orleans.

Isaacs

H.S. Isaacs and A.J. Aldykiewicz, "Distribution of Chromium Species in Chromate Conversion Coatings," Spring Meeting of The Electrochemical Society, San Diego, California, 1998.

C. S. Jeffcoate, H. S. Isaacs, J. Hawkins, G. Thompson, "The Effect of Chromate Concentration on the Repassivation of Corroding Aluminum, " Fall Meeting of The Electrochemical Society, Boston, MA, (1998).

C. S. Jeffcoate and H. S. Isaacs "Chromate as an inhibitor for Aluminum," Research in Progress Symposium, Corrosion '99, NACE, (1999).

C. S. Jeffcoate, M. P. Ryan, G. P. Bierwagen, "Current Density Mapping of Coated Aluminum Alloys During Corrosion in Aqueous Electrolyte," H. S. Isaacs, Fall Meeting of The Electrochemical Society, Boston, MA, (1998).

H. S. Isaacs, G. Adzic, and C. S. Jeffcoate, "Corrosion of Aluminum" 2000 Spring Meeting of the Materials Research Society, San Francisco, April 24-28, 2000. **Invited talk.**

H. S. Isaacs, "Studying Corrosion Processes with X-Ray Absorption Techniques,"

14th International Corrosion Congress, Cape Town, Sept. 28, 1999. **Invited talk.**

H. S. Isaacs, "Effect of Anions on the Behavior of Passive Films on Metals." Israel Institute of Technology, Haifa, May 21, 2000. **Invited talk.**

H. S. Isaacs, G. Adzic, and C. S. Jeffcoate, "Visualizing Corrosion" University of Utah, Aug. 11, 2000. **Invited talk.**

H. S. Isaacs, F Xu., and C. S. Jeffcoate, "Dissolution of oxide films on aluminum in near neutral solutions," Fall Meeting of the Electrochemical Society, Honolulu, HI, 1999.

H. S. Isaacs, C. S. Jeffcoate, N. A. Missert., and J. C. Barbour, "Ionic current mapping techniques and applications to aluminum-copper corrosion." Fall Meeting of The Electrochemical Society Honolulu, HI, Oct. 1999.

H. S. Isaacs, "Visualizing Corrosion Processes" Whitney Award Lecture, NACE2000, Orlando, 3/00. **Invited talk.**

H. Lee, H. Isaacs, and F. Xu, "Cyclic Polarization Behavior of Aluminum Oxide Films in Near Neutral Solutions," Spring Meeting of The Electrochemical Society, Washington, DC, 2001.

H. Isaacs, "In Situ Studies of Corrosion Using X-ray Absorption Near Spectroscopy and Fluorescence Techniques," The Electrochemical Society, 199th Meeting, Washington, DC, March, 2001.

K. Sasaki, H. Isaacs, and P. Levy, "Insights into Electrochemical Noise of Aluminum in Chloride Environments" Fall Meeting of The Electrochemical Society, Meeting. San Francisco, CA, 2001.

K. Sasaki, and H. Isaacs, "Investigating the Origins of Chromate Inhibition on Corrosion of Aluminum and Its Alloys by Electrochemical Noise Measurements," Fall Meeting of The Electrochemical Society, San Francisco, CA, 2001

H. Lee and H. Isaacs, "Effects of Anion, pH, and Temperature on Dissolution Behavior of Aluminum Oxide Films" Fall Meeting of The Electrochemical Society, Meeting. San Francisco, CA, 2001

Kendig

M. Kendig, R. Addison, S. Jeanjaquet and E. Cheng, "Piezo-Electrochemical Response of Chromate Sealed Anodized Aluminum", Research in Progress Symposium, Corrosion '98.

M. Kendig, S. Jeanjaquet, R. Addison and J. Waldrop, "Role of Hexavalent Chromium in the Inhibition of Corrosion of Aluminum Alloys", DoD Metal Finishing Workshop, August 1998.

M. Kendig, S. Jeanjaquet, E. Cheng, M. Elhamid, H. Pickering, "Inhibition of Cathodic Reactions on Iron – The Synergism of Zn and Benzotriazole", Extended Abstract, 193rd Meeting of the Electrochemical Society, San Diego, CA (1998).

M. Kendig and S. Jeanjaquet, "Inhibition of Electrochemical Reactions on Cu-Rich Aluminum Intermetallics", Extended Abstract, Accepted for Presentation at the 194th Meeting of the Electrochemical Society, Boston, MA (1998).

M. Kendig, R. Addison, and S. Jeanjaquet, "Piezo-electrokinetic (PEK) Determination of the pH of Zero Charge for Anodized Aluminum Oxide Films", Extended Abstract Accepted for Presentation at the 194th Meeting of the Electrochemical Society, Boston, MA (1998).

M. Kendig, R. McCreery, J. Ramsey, Lin Xia, "Speciation Of Oxo-Chromium(VI) Anions And The Corrosion Inhibition Of Al Alloys", presented at the Fall 1999 Meeting of the Electrochemical Society.

M. Kendig, S. Jeanjaquet and Y. Chung, "The Influence of Macroscopic Surface Area on Electrochemical Impedance of Al 2024-T3", to be presented at the Fall Meeting of the Electrochemical Society.

M. Kendig, S. Jeanjaquet, R. Buchheit, H. Guan, R. Leard and J. Frankel "Electrochemical Aspects of Dealloyed (Cu,Mg)Al₂", to be presented at the Fall 2000 Meeting of the Electrochemical Society.

M. Kendig and R. Buchheit, "Corrosion Inhibition of Al and Al Alloys by Hexavalent Cr Compounds. A Mechanistic Overview", 'Surface Conversion of Aluminum and Ferrous Alloys for Corrosion Resistance', R. Buchheit, M. R. Jaworoski, P. D. Chalmer, eds., Research Topical Symposium, Corrosion/2000, NACE, Houston, TX, USA (2000).

M. Kendig, "Localized Corrosion of Al Alloys", Seminar at Ohio State University, May 2000.

M. Kendig, "Piezo Electrokinetic Investigation of Chromate Adsorption on Anodized Aluminum", University of Virginia Seminar, October 1999.

M. Kendig, Jeanjaquet, Buchheit, Guan and Leard, "Electrochemical Aspects of Dealloyed (Cu, Mg) Al₂", Abstract No 274, Fall 2000.

M. Kendig, S. Jeanjaquet and Y. Chung, "The Influence of Macroscopic Surface Area on Electrochemical Impedance of Al 2024-T3, Abstract No. 299, Fall 2000.

Clayton

S. V. Kagwade, C. R. Clayton, M. L. Du, and F. P. Chiang, "The Effect of Acetone Cleaning on the Corrosion Behavior of AA2024-T3 in a Mist of 0.5 M NaCl", Abstract 393, 192nd Electrochemical Society Meeting; Paris; France, August 31-Sept. 5, 1997.

C. R. Clayton, G. P. Halada and S. V. Kagwade, "Factors Influencing the Reduction of Hexavalent Chromium during X-ray Photoelectron Spectroscopy", Abstract VT+FP+AS-TuA9, 44th American Vacuum Soc. National Symposium; San Jose CA; October 20-24, 1997.

C. R. Clayton, S. V. Kagwade, G. P. Halada, and J. R. Kearns, "Photochemical Stability of Chromates and Conversion Coatings on Aluminum Alloys", Abstract 113, 193rd Electrochemical Society Meeting; San Diego CA; May 3-8, 1998.

J. R. Kearns, S. V. Kagwade, G. P. Halada, C. R. Clayton, S. L. Jeanjaquet and M. W. Kendig, "Surface Pretreatments for Chromate Conversion Coating on AA2024-T3 Alloy", Abstract 116, 193rd Electrochemical Society Meeting; San Diego CA; May 3-8, 1998.

G. P. Halada, J. R. Kearns, M. E. Monserrat, M. J. Vasquez, C. R. Clayton, S. Jeanjaquet and M. W. Kendig, "Influence of Surface Chemistry on Electrochemical Behavior of Intermetallic Particles in AA2024-T3", Abstract 133, 193rd Electrochemical Society Meeting; San Diego CA; May 3-8, 1998.

G. P. Halada, J. R. Kearns, and C. R. Clayton, G. L. Carr, G. P. Williams and L. M. Miller, "Synchrotron FTIR Analysis of Surface-Treated AA2024-T3, Abstract No. 199, 194th Electrochemical Society Meeting; Boston MA; November 1-6, 1998

J. R. Kearns, C. R. Clayton, G. P. Halada, R. McCreery, G. Shea-McCarthy, L. M. Miller, "Speciation and Stability of Compounds in Conversion Coatings on Aluminum Alloys by XPS and Synchrotron Techniques," Abstract No. 204, 194th Electrochemical Society Meeting; Boston MA; November 1-6, 1998.

M. J. Vasquez, G. P. Halada, C. R. Clayton, J. R. Kearns, "Thin-Film Analogs of Intermetallic Particle Compositions in AA2024-T3," Abstract No. 205, 194th Electrochemical Society Meeting; Boston MA; November 1-6, 1998.

C. R. Clayton, S. V. Kagwade, and G. P. Halada, "Photochemical Reaction of Organics on Copper and Copper-Containing Aluminum Alloys, Abstract No. 250, 194th Electrochemical Society Meeting; Boston MA; November 1-6, 1998.

G. P. Halada, J. R. Kearns, C. R. Clayton, M. W. Kendig and S. Jeanjaquet, "Surface Composition of Intermetallic Precipitates in AA2024-T3," Abstract No. 231, 194th Electrochemical Society Meeting; Boston MA; November 1-6, 1998.

G. P. Halada, C. R. Clayton, M. J. Vasquez, D. Chidambaram, J. R. Kearns, R. D. Granata, G. L. Carr and L. M. Miller, "Role of Organochromates in Polymer Coatings for Aerospace

Applications Assessed by Grazing-Angle Far-Infrared Microspectroscopy,” Session C1- Corrosion and Prevention in Air and 195th Electrochemical Society Spring 1999 in Seattle WA May 2-7, 1999.

C. R. Clayton, G. P. Halada, M. J. Vasquez, D. Chidambaram, J. R. Kearns, R. D. Granata, S. H. McKnight, G. Shea McCarthy and G. L. Carr, “The Effect of Aging in Air on the Surface Composition and Structure of Chromate Conversion Coated Aluminum Alloys,” 195th Electrochemical Society Spring 1999 in Seattle WA May 2-7, 1999.

C. R. Clayton, G. P. Halada, M. J. Vasquez, J. R. Kearns, D. Chidambaram, and R.D. Granata, “Hydrophobicity and Structural Stability During Aging of Chromate Conversion Coatings on Al Alloys”, Abstract No 512, 196th Electrochemical Society Meeting; Honolulu, Hawaii; October 17-22, 1999.

C. R. Clayton, G. P. Halada, D. Chidambaram, and M. J. Vasquez, “On the Bipolar Mechanism for Chromate-Induced Repassivation of Active Sites on Chromate Conversion Coated Aluminum Alloys”, Abstract No. 531, 196th Electrochemical Society Meeting; Honolulu, Hawaii; October 17-22, 1999.

G. P. Halada, C. R. Clayton, M. J. Vasquez, J. R. Kearns, D. Chidambaram, and R.D. Granata, “Heterogeneity in Commercial Coating Systems for Aerospace Applications”, Abstract No. 615, 196th Electrochemical Society Meeting; Honolulu, Hawaii; October 17-22, 1999.

S.V. Kagwade, C.R. Clayton, M.L. Du and F.P. Chiang, “The Effect of Acetone Cleaning on the Corrosion Behavior of AA2024-T3 in a Mist of 0.5M NaCl”, Display No. 0008, 1999 Tri-Service Conference on Corrosion, Myrtle Beach, SC; November 15-19, 1999.

J. R. Kearns, S.V. Kagwade, G.P. Halada, S.L. Jeanjaquet and M.W. Kendig, “Surface Pretreatments for Chromate Conversion Coatings on AA2024-T3 Alloy”, Display No. 0009, 1999 Tri-Service Conference on Corrosion, Myrtle Beach, SC; November 15-19, 1999.

G. P. Halada, C. R. Clayton, M. J. Vasquez, J. R. Kearns, D. Chidambaram, R.D. Granata, and J.K. Hirvonen, “Heterogeneity in Commercial Coating Systems for Aerospace Applications”, Abstract No. 1630, 1999 Tri-Service Conference on Corrosion, Myrtle Beach, SC; November 15-19, 1999.

M. J. Vasquez, G. P. Halada, C. R. Clayton, “Composition of Surface Treated Thin Film Analogs of Intermetallic Constituents in AA2024-T3”, Abstract No. 211, 197th Electrochemical Society Meeting; Toronto, Ontario, Canada; May 14-19, 2000.

D. Chidambaram, M. J. Vasquez, C. R. Clayton, and G. P. Halada, “Study of the Electrochemical Behavior of Intermetallic Particles in AA2024-T3”, Abstract No. 212, 197th Electrochemical Society Meeting; Toronto, Ontario, Canada; May 14-19, 2000.

D. Chidambaram, C. R. Clayton and G. P. Halada, "On the Electrochemical Behavior of Dichromate and Molybdate Treated Intermetallic Particles Present in AA2024-T3", Abstract No. 282, The 198th Meeting of the Electrochemical Society, Phoenix, Arizona; October 22-27, 2000.

M. J. Vasquez, G. P. Halada, C. R. Clayton and J. P. Longtin, "Composition of Surface Treated Thin Film Analogs of Intermetallic Constituents in AA2024-T3", Abstract No. 281, The 198th Meeting of the Electrochemical Society, Phoenix, Arizona; October 22-27, 2000.

M. J. Vasquez, G. P. Halada, C. R. Clayton and J. P. Longtin, "Effects of Aging on Chromate Conversion Coatings Formed on AA2024-T3 and Some Intermetallic Constituents", Abstract No. 286, The 198th Meeting of the Electrochemical Society, Phoenix, Arizona; October 22-27, 2000.

G. P. Halada and C.R. Clayton, "Applications of Synchrotron Infrared Microspectroscopy (SIRMS) to Corrosion, Contamination and Coatings", Abstract No. 156, The 199th Meeting of the Electrochemical Society, Washington, D.C.; March 25-30, 2001.

D. Chidambaram, C. R. Clayton, G. P. Halada and J. R. Kearns, "Effect of Surface Pretreatments on Chromate Conversion Coatings" Abstract No. 167, The 199th Meeting of the Electrochemical Society, Washington, D.C.; March 25-30, 2001.

M. J. Vasquez, G. P. Halada, C. R. Clayton", M. J. Vasquez, G. P. Halada and C. R. Clayton, "Studies of The Structure and Formation of Chromate Conversion Coatings on Thin Films of Copper-Containing Intermetallic Constituents in AA2024-T3", Abstract No. 170, The 199th Meeting of the Electrochemical Society, Washington, D.C.; March 25-30, 2001.

D. Chidambaram, C. R. Clayton and G. P. Halada, "Studies on the Repassivation Behavior of Aluminum Exposed to Dichromate Solution", Abstract No. 173, The 199th Meeting of the Electrochemical Society, Washington, D.C.; March 25-30, 2001.

D. Chidambaram, "Infrared Studies on Aluminum Alloy 2024-T3", (*Invited*) Users Workshop & Meeting - National Synchrotron Light Source, Brookhaven National Laboratory, Upton, NY; May 25, 2001.

Stratmann

W. Schmidt; M. Stratmann, „Scanning Kelvinprobe Investigations of Filiform Corrosion on Aluminum," 193rd Electrochemical Society Meeting; San Diego, CA, May 1998.

W. Schmidt; M. Stratmann, "Corrosion of Polymer Coated Aluminum Alloys," Annual MURI Meeting, Florida, Jan 1999.

M. Stratmann; J. Vander Kloet; W. Schmidt; A.W. Hassel, "Investigations into the Role of Copper in AA2024-T3 Aluminium Alloys on Filiform Corrosion Advancement and the Role of Chromium in Corrosion Inhibition," Annual MURI Meeting, Florida, Jan. 2001.

M. Stratmann; J. Vander Kloet; W. Schmidt; A.W. Hassel, "Investigations into the Role of Copper in AA2024-T3 Aluminium Alloys on Filiform Corrosion Advancement and the Role of Chromium in Corrosion Inhibition," 63rd AGEF Seminar, Düsseldorf, April 20-21, 2001.

J. Vander Kloet; W. Schmidt; A.W. Hassel, M. Stratmann, "Filiform Investigations on Aluminum Alloy 2024-T3," Electrochemical Society Annual Conference, San Francisco, Sept 2-7, 2001.

A. W. Hassel, J. Vander Kloet, W. Schmidt, M. Stratmann "In-situ SKP Investigation and ToF-SIMS Analysis of Filiform Corrosion on Aluminium Alloy 2024-T3," 48th Meeting of the Japan Society of Corrosion Engineering, Materials and Environments, Sapporo, Japan, Sept 26-28, 2001.

Granata

R.D. Granata, "Methods of Quantitative Coatings Evaluation - Testing the Better Mouse Trap," Coatings Workshop Office of Naval Research/Naval Surface Warfare Center – Carderock Detachment, August 16, 2001, Myrtle Beach, SC, Invited Speaker.

M.M. Madani, R.M. Simmons, K.M. Mann, Y.M. Sigonney, R.R. Miron and R.D. Granata, "Chromate Inhibition of Polymer-Coated Aluminum Alloy 2024-T3," Fall (2000) Meeting of the Electrochemical Society, Phoenix, AZ, Paper 287.

M.M. Madani, Y.M. Sigonney, R.D. Granata and R.R. Miron, "Electrochemical Impedance Study of Chromate Inhibition on Polymer-Coated Aluminum Alloy 2024-T3," Spring (2000) Meeting of the Electrochemical Society, Toronto, Canada, Paper 123.

M.M. Madani, R.R. Miron, R.D. Granata, "CONTIN Analysis of PALS for Interface Free Volume Measurements," *Proceedings of the American Physical Society*, Atlanta, GA, March 26, 1999.

R.D. Granata, "Non-Electrochemical Methods of Quantitative Coatings Evaluation," Coatings Workshop Office of Naval Research/Naval Surface Warfare Center – Carderock Detachment, Bethesda, MD, October, 1999, Invited Speaker.

R.D. Granata, R.R. Miron and M.M. Madani, "Electrochemical Impedance Study of Chromate Inhibition on Epoxy-Coated Al Alloy 2024-T3," 1998 Fall Meeting of The Electrochemical Society, Boston, MA, 11/5/98.

R.D. Granata, R.C. MacQueen, R.R. Miron, H.L. Vedage and M.M. Madani, "PALS Free Volume Studies of Protective Polymer Coatings," *CORROSION'97 Conference: Research in Progress Symposium*, NACE, March, 1997.

M.M. Madani and R.D. Granata, "Free Volume Changes in Water Containing Cr(VI) and Cr(III) Using PALS," in Positron Annihilation ICPA-11, Proceedings of the 11th International Conference on Positron Annihilation, Kansas City, Missouri, USA, May, 1997.

7.2 Consultative and Advisory Functions

Numerous.

7.3 Transitions

The MURI team has developed interactions on closely related projects that strongly leverage the MURI funds. Several funding opportunities in the area of Al alloy corrosion and inhibition have developed in the past years, and the MURI team members have taken advantage of them to broaden the scope of work in their respective groups. Strategic Environmental Research and Development Program (SERDP) has funded several activities in areas related to the topics of interest to the Air Force. One SERDP program is on a topic that is very similar to that of this MURI, the role of chromate inhibition of Al alloys. The PI of the SERDP program is R. Buchheit at OSU, and G. Frankel and R. McCreery are participants in the SERDP program. The co-location of the SERDP and MURI programs has ensured that there were no blatant duplication of effort, and, as mentioned, leverages the funds. Stony Brook is involved in another SERDP project with ARL on degradation of polymeric coatings used in military applications. G. Frankel has funds from AFOSR for another project on Al alloy localized corrosion kinetics. The results of that project relate closely to the MURI work. H. Isaacs is a team member on a DoE BES funded effort based at Sandia National Labs on the production and study of Al samples with controlled defects.

The artificial scratch technique that was developed in this work has been used by R. Buchheit's group at OSU to assess the ability of Ce-based inhibitors to exhibit active corrosion inhibition in a fashion similar to how chromates act.

A rapid test for screening inhibitor effectiveness was developed in this program by Rockwell Science Center and used to screen a number of inhibitors in a proprietary Boeing supported IRAD program. From the results we have identified a pre-commercial non-chromate pigment for possible use in a novel Boeing Advanced Performance Coatings (APC) concept.

The work on PEK analysis of Ce adsorption on anodized Al performed at Rockwell Science Center supports the Boeing development program in this area.

Based upon suggestions by FAU, the PALS 1000 (temperature-controlled positron annihilation lifetime spectrometer) has been modified by the vendor (Perkin-Elmer, Inc.) to enhance physical ruggedness and to improve high resolution measurements for multiphase polymeric coatings.

Agere Inc. and Standard MEMS Inc. directly benefited from aspects of research findings at State University of New York Stony Brook.

8 New discoveries, inventions, and patent disclosures

Three invention disclosures were submitted at Rockwell Science Center:

98SC123 "Smart Tape for Sensing Hidden Corrosion"

99SC103 "Ferrate-Based Corrosion Inhibitors"

01SC052 "Rapid Test of the Efficacy of Corrosion Inhibitors for 2000 Series Al Alloys"

9 Honors/Awards

G. Frankel was promoted to the rank of Professor, 2000.

G. Frankel was awarded the H. H. Uhlig Educators Award from NACE, 2000.

G. Frankel was awarded the following OSU College of Engineering Awards: Harrison Faculty Award, 2000; Lumley Research Award, 1999; Research Accomplishment Award, 1997.

G. Frankel was elected to and served as chairman of the 2000 Gordon Conference on Aqueous Corrosion.

Richard L. McCreery received the 2000 Analytical Division award in Electrochemistry from ACS.

Richard L. McCreery was named Dow Professor of Chemistry, 1998.

Clive R. Clayton promoted to Leading Professor, 2001.

Marvin J. Vasquez received W. Burghardt Turner Dissertation Fellowship (2001-2002).

G. P. Halada received a Stony Brook award for innovative teaching.

Murat Basaram, High School student was a semifinalist in the Intel competitions for "The Use of Reactive Arc Melting and Thin Film Deposition Techniques to Make Analogs of Intermetallic Particles Found in Aerospace Aluminum Alloy (AA2024-T3)" for his work at Stony Brook.

Hugh Isaacs received the Whitney Award from NACE, 2000.

Hugh Isaacs was awarded NACE and ECS fellowships in 1996.

Martin Stratmann was hired as Scientific Member and Director at Max-Planck-Institut für Eisenforschung in Düsseldorf, 2000.

Richard Granata was hired as Professor of Ocean Engineering at Florida Atlantic University, 1999