

AFRL-SN-WP-TR-2001-1053

**ELECTRONIC WARFARE (EW)
RECEIVER AND PROCESSING
CONCEPTS EVALUATION PROGRAM
(RAPCEval 2)**

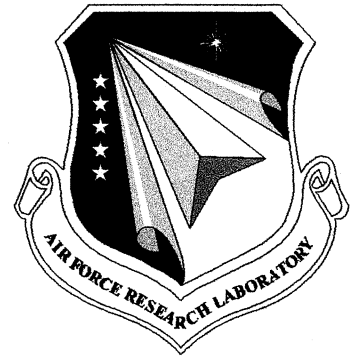

DR. W. THOMAS BASS

**MERCER ENGINEERING RESEARCH CENTER
A UNIT OF MERCER UNIVERSITY
135 OSIGIAN BOULEVARD
WARNER ROBINS, GA 31088**

MAY 2001

FINAL REPORT FOR PERIOD 01 APRIL 2000 – 11 MAY 2001

Approved for public release, distribution unlimited.

**SENSORS DIRECTORATE
AIR FORCE RESEARCH LABORATORY
AIR FORCE MATERIEL COMMAND
WRIGHT-PATTERSON AIR FORCE BASE, OH 45433-7318**

NOTICE

USING GOVERNMENT DRAWINGS, SPECIFICATIONS, OR OTHER DATA INCLUDED IN THIS DOCUMENT FOR ANY PURPOSE OTHER THAN GOVERNMENT PROCUREMENT DOES NOT IN ANY WAY OBLIGATE THE US GOVERNMENT. THE FACT THAT THE GOVERNMENT FORMULATED OR SUPPLIED THE DRAWINGS, SPECIFICATIONS, OR OTHER DATA DOES NOT LICENSE THE HOLDER OR ANY OTHER PERSON OR CORPORATION; OR CONVEY ANY RIGHTS OR PERMISSION TO MANUFACTURE, USE, OR SELL ANY PATENTED INVENTION THAT MAY RELATE TO THEM.

This report is releasable to the National Technical Information Service (NTIS). At NTIS, it will be available to the general public, including foreign nations.

THIS TECHNICAL REPORT HAS BEEN REVIEWED AND IS APPROVED FOR PUBLICATION.

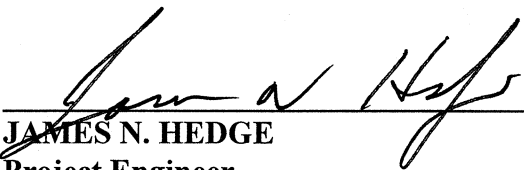

JAMES N. HEDGE
Project Engineer
Applied Aperture & Receiver Branch
RF Sensors Technology Division
Sensors Directorate

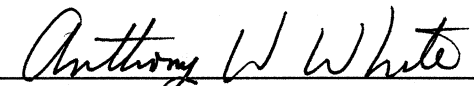

ANTHONY W. WHITE
Chief
Applied Aperture & Receiver Branch
RF Sensors Technology Division
Sensors Directorate



WILLIAM E. MOORE
Chief
RF Sensors Technology Division
Sensors Directorate

Do not return copies of this report unless contractual obligations or notice on a specific document requires its return.

REPORT DOCUMENTATION PAGE

Form Approved
OMB No. 0704-0188

Public reporting burden for this collection of information is estimated to average 1 hour per response, including the time for reviewing instructions, searching existing data sources, gathering and maintaining the data needed, and completing and reviewing the collection of information. Send comments regarding this burden estimate or any other aspect of this collection of information, including suggestions for reducing this burden, to Washington Headquarters Services, Directorate for Information Operations and Reports, 1215 Jefferson Davis Highway, Suite 1204, Arlington, VA 22202-4302, and to the Office of Management and Budget, Paperwork Reduction Project (0704-0188), Washington, DC 20503.

1. AGENCY USE ONLY (Leave blank)		2. REPORT DATE MAY 2001	3. REPORT TYPE AND DATES COVERED Final 04/01/2000 – 05/11/2001	
4. TITLE AND SUBTITLE ELECTRONIC WARFARE (EW) RECEIVER AND PROCESSING CONCEPTS EVALUATION PROGRAM (RAPCEval 2)			5. FUNDING NUMBERS C: F09603-93-G-0012 PE: 62204 PR: 7633 TA: 11 WU: AM	
6. AUTHOR(S) DR. W. THOMAS BASS				
7. PERFORMING ORGANIZATION NAME(S) AND MERCER ENGINEERING RESEARCH CENTER A UNIT OF MERCER UNIVERSITY 135 OSIGIAN BOULEVARD WARNER ROBINS, GA 31088			8. PERFORMING ORGANIZATION REPORT NUMBER MR000511.01-RV-01	
9. SPONSORING/MONITORING AGENCY NAME(S) AND SENSORS DIRECTORATE AIR FORCE RESEARCH LABORATORY AIR FORCE MATERIEL COMMAND WRIGHT-PATTERSON AIR FORCE BASE, OHIO 45433-7318 POC: JAMES N. HEDGE, AFRL/SNRP (937) 255-6127 EXT. 4349			10. SPONSORING / MONITORING AGENCY REPORT NUMBER AFRL-SN-WP-TR-2001-1053	
11. SUPPLEMENTARY NOTES				
12a. DISTRIBUTION / AVAILABILITY STATEMENT Approved for public release, distribution unlimited.			12b. DISTRIBUTION CODE	
13. ABSTRACT (Maximum 200 words) The EW Receiver and Processing Concepts Evaluation Program (RAPCEval 2) tasks have provided analytical support for current research for the Electronic Signal Measurement (ESM) group at Air Force Research Laboratory (AFRL). Tasks initiated under OPTION 3 of the contract of this program provided analysis for inputs and countermeasures for electronic receivers of radar, electro-optic, infrared, and ultraviolet systems. Research has been performed under the direction of the Joint Program Research Standards Committee, composed of members from Wright-Patterson AFB, Warner Robins AFB, Mercer University, and Mercer Engineering Research Center. The report includes research presentations from graduate students and a research presentation by a university faculty member. Topics included are represented by the keyword list on this same page.				
14. SUBJECT TERMS error correction, Reed-Solomon, transform domain communication, signal processing, phased-array antenna, multipath, collision avoidance, ATRCB, autofocus, phase errors			15. NUMBER OF PAGES 186	
			16. PRICE CODE	
17. SECURITY CLASSIFICATION OF REPORT UNCLASSIFIED	18. SECURITY CLASSIFICATION OF THIS PAGE UNCLASSIFIED	19. SECURITY CLASSIFICATION OF ABSTRACT UNCLASSIFIED	20. LIMITATION OF ABSTRACT SAR	

TABLE OF CONTENTS

<u>Section</u>	<u>Page</u>
1. EXECUTIVE SUMMARY	1
2. INTRODUCTION.....	2
2.1 EW RECEIVER EFFORT	2
2.2 EW PROCESSING EFFORT	2
2.3 EW EXCITER EFFORT	2
2.4 EW ANTENNA EFFORT	2
3. SCOPE	3
4. RESEARCH SUPPORT.....	4
5. PROJECT ACTIVITY.....	5
5.1 STEERING COMMITTEE, MAY 2001	5
5.1.1 <i>Meeting Minutes</i>	5
5.1.2 <i>Agenda</i>	7
5.1.3 <i>Attendance Roster</i>	8
5.1.4 <i>Overview of the Program</i>	9
5.1.5 <i>Presentation by Houston Jones</i>	21
5.1.6 <i>Presentation by Mark Napier</i>	61
5.1.7 <i>Presentation by Zoran Sevarlic</i>	95
5.1.8 <i>Presentation by Bill Elliott</i>	141
5.2 REPORT BY DR. BEHNAM KAMALI	162
6. CONCLUSIONS AND PLANS FOR FUTURE ACTIVITY.....	174
LIST OF ABBREVIATIONS AND ACRONYMS	176

1. EXECUTIVE SUMMARY

This report describes work accomplished under contract Option 4 of the Electronic Warfare (EW) Receiver and Processing Concepts Evaluation Program (RAPCEval 2). The Air Force Research Laboratory (AFRL) awarded this contract. This branch of AFRL is located at Wright-Patterson Air Force Base (WPAFB), Ohio. Work was completed on the RAPCEval 1 contract in October 1996, and the basic contract for RAPCEval 2 was initiated in November 1996. The project includes four options and has maximum duration of 60 months from the date of award. The Option 4 task of this program was awarded to Mercer Engineering Research Center (MERC) in 2000. This report describes work accomplished on the contract from April 1, 2000 through May 11, 2001. In support of the contract, a number of activities and projects have been initiated. Some of these are complete, and many more are continuing. A number of activities have spawned new directions for investigative effort.

The Program Research Standards Committee (PRSCComm), established at the outset of the Basic task, has continued to meet regularly and has provided valuable guidance and suggestions both as to the direction of students involved in the effort, and the scope and emphasis of the research efforts in general. Current membership of this committee represents the AFRL, Robins Air Force Base, Mercer University, and MERC. The specific members are listed in another section of this report (Section 4, Research Support).

One meeting of the PRSCComm was held during contract Option 4. A number of student research reviews were presented and were approved by the PRSCComm in the course of these meetings (see Section 5, Project Activity). Valuable discussion and suggestions were provided for directing and focusing the students' work. In addition, several committee members suggested ways to reduce the scope or better focus research efforts. Frequently, unanticipated or unknown resources and techniques were pointed out for the benefit of the students. Another item included is a brief report summarizing research by Dr. Behnam Kamali, who has advised a number of the RAPCEval student theses. To become better acquainted with research topics of interest to AFRL, Dr. Kamali last year traveled to Dayton, Ohio, to discuss with AFRL researchers research directions of mutual interest. Having chosen transfer domain communication for further study, Dr. Kamali spent several weeks in the summer of 2000 brushing up on the topic, including the study of several theses furnished by AFRL. This is the basis for the included report. We expect several students in the future to be able to conduct research in that area with Dr. Kamali's direction.

Students engaged in the RAPCEval program have continually enjoyed fruitful contact with knowledgeable personnel at the AFRL in their respective areas of interest. They have also interacted with experienced colleagues at Robins Air Force Base (AFB), employees of MERC, Mercer University School of Engineering faculty, and various representatives of industry.

The RAPCEval contract has stimulated gratifying communication and collaborative research effort among students, university faculty, MERC personnel, and personnel at the AFRL, Warner Robins AFB and industry. All parties have expressed satisfaction with the contract results.

2. INTRODUCTION

These tasks specify requirements for analytical and research support of in-house research at the AFRL in the Sensors Division (SNR). There is increasing sophistication, quantity, and mobility of hostile radars, such as anti-aircraft missile (AAM), surface-to-air missile (SAM), and anti-aircraft artillery (AAA) fire control systems. The EW receivers for radar, electro-optic, infrared, ultraviolet missile warning, and electronic countermeasures need operational upgrades to allow penetrating aircraft acceptable survivability. This encourages maintenance of in-house laboratories to support development, to evaluate concepts, and to test new receivers, processors, and software.

2.1 EW Receiver Effort

Complex EW environments have caused employment of numerous receiving systems. Augmentation of in-house capability for evaluation, novel concept development, and exploitation of new technology is needed. Computer-aided simulation of new systems and concepts can save resources. New high-speed analog-to-digital (A/D) converter technology may allow input frequencies to be digitized in base-band before the crystal video detector, possibly allowing real-time digitized frequency, pulse width, and pulse amplitude. Advancing materials technology for infrared (IR)/ultraviolet (UV)/radio frequency (RF) energy offers the possibility of augmented and combined sensors. Investigation of these materials is needed to reduce the kind and number of avionics needed in combat. Advances in signal filtering and discrimination, in both hardware and software, may allow enhancement of fielded EW systems.

2.2 EW Processing Effort

A modern EW system must face an increasing number of hostile multimode threats. Sensors to intercept such threats now include radar warning and electronic intelligence systems. Information from these sensors must be processed, the threat identified, and appropriate countermeasures initiated to counter these threats. An augmentation of in-house capability is required to evaluate processor hardware and software, to exploit novel ideas, and to investigate advanced concepts such as artificial intelligence to determine the nature of the threat, and what countermeasures, if any, to employ.

2.3 EW Exciter Effort

Digital exciters are being developed to provide a flexible active electronic countermeasures (ECM) asset against a wide variety of modern threats. The need exists to evaluate the various exciter architectures, advance and develop unique concepts, and advance the digital exciter technology base. The novel concepts and technologies must be evaluated for effectiveness against the proposed application.

2.4 EW Antenna Effort

The role of antennas as the “eyes and ears” of the sensor suites continues to make RF antenna technology development vital to the Air Force mission. Airborne antenna apertures of the future will be low cost, broadband, low radar cross section (RCS), and multifunction in nature to earn their way onto platforms where space is at a premium.

3. SCOPE

The overall program consists of a basic task and four options that are the conglomerate of different work efforts and technologies within the EW arena. Detailed descriptions are given as follows:

- Basic Task - The Basic task will provide the tasks necessary to analyze software and hardware approaches to perform the exploratory development of EW technology in these hardware technology areas: radar, laser, IR, and UV. The task will analyze receiver and exciter technology to generate ECM signals to improve ECM system performance. In addition, the scope of the Basic task will include signal-processing technology related to the hardware.
- Option 1 - These tasks will be those necessary to analyze receiver technology for application to modern digital spectrum estimation techniques in order to improve EW/signal intelligence (SIGINT)/electronic intelligence (ELINT)/IR/electro-optical (EO) receiver performance.
- Option 2 - This option consists of those tasks necessary to identify high risk design areas for an EW/SIGINT/ELINT/IR/EO hardware approach, to perform exploratory design assessments for selected functions, and to determine the degree of parallel processing achievable.
- Option 3 - This option is “reserved” and will not be funded.
- Option 4 - These tasks are those essential to EW/SIGINT/ELINT/IR/EO hardware and signal processing including, but not limited to, pulse-deinterleaving, parametric extraction, and threat identification.

It should be noted that software generated under this contract is not government owned.

4. RESEARCH SUPPORT

For support of the overall contract, a PRSComm was established. Membership for this committee was most recently updated March 1997. Current members are as follows:

- from the AFRL at WPAFB,
 - Mr. Nicholas Pequignot (the program manager for AFRL)
 - Mr. Emil R. Martinsek
 - Mr. Norman A. Toto
 - Dr. Duane A. Warner
 - Mr. Paul J. Westcott

- from Warner Robins Air Logistics Center (WR-ALC),
 - Mr. Steve Strawn (the program manager for WR-ALC)
 - Mr. John LaVecchia
 - Mr. Phil Oliver
 - Mr. Ches Rehburg
 - Mr. Larry Sheets

- from Mercer University and MERC,
 - Dr. Tom Bass (the program manager for MERC)
 - Dr. David Barwick (chairman of the standards committee)
 - Dr. Aaron Collins (Mercer University)
 - Dr. Behnam Kamali (Mercer University)
 - Dr. Paul MacNeil (Mercer University).

The EW Receiver and Processing Concepts Evaluation Program was awarded to MERC by WPAFB/AFRL under contract F09603-93-G-0012-0017. This contract is administered through WR-ALC. The overall program has a funding ceiling of \$499,940. Incremental funding will be accomplished via a series of contract options. The basic contract is \$99,998, Option 1 is \$99,998, Option 2 is \$99,998, Option 3 is "reserved," and Option 4 is \$49,998.

Funds have been provided for the basic program, Option 1, Option 2, and Option 4.

5. PROJECT ACTIVITY

5.1 Steering Committee, May 2001

5.1.1 Meeting Minutes

EW Receiver and Processing Concepts Evaluation Program Program Research Standards Committee Meeting

Minutes - 3 May 2001

A meeting of the Program Research Standards Committee (PRSComm) for the RF/Receiver and Processing Concepts Evaluation Program (RAPCEval) was hosted by Mercer Engineering Research Center (MERC) on May 3, 2001 at 1:30 p.m. Committee members present were Tom Bass, Dave Barwick, James Hedge, Behnam Kamali, Paul MacNeil, Phil Oliver, and Nick Pequignot. Also present were several representatives from Mercer University faculty and the Center, personnel from Warner Robins Air Force Base, and Tuskegee University, and four students, who presented talks. All of the talks were presentations of research in progress, although initial proposals by new students are expected in the near future.

After a brief welcome by Dave Barwick, Tom Bass introduced the students who were scheduled to speak: Houston Jones, Mark Napier, Zoran Sevarlic, and Bill Elliot. Tom highlighted briefly some accomplishments of students who have completed the program. During these remarks, Nick Pequignot noted that two new representatives from The Air Force Research Laboratory (AFRL) would be joining the Steering Committee to replace two retiring members, Emil Martinsek and Norman Toto. Those joining the Committee are Tony White and James Hedge. James will become program manager, replacing Nick Pequignot in that capacity.

Houston Jones began his presentation on error correction in a multipath fading environment at 1:55. The fading effect is experienced in the wireless environment and is due to both multipath and Doppler effects. Mr. Jones has used ACOLADE simulation software to define baseline performance of QPSK modulated signals without the use of error correction technique. Subsequently he has added Reed-Solomon coding, convolutional codes, and concatenating codes to the baseline in order to gauge the error correcting effectiveness of each. The data that he has collected has enabled him to demonstrate interesting conclusions as to the comparable effectiveness of the three techniques and the SNR required to achieve a specified bit error rate.

The next speaker, Mark Napier, began at 2:30 to describe his work on the use of Reed-Solomon encoding to improve a proposed aircraft collision avoidance system. After consulting with Lincoln Laboratory, Mark realized that channel fading is not normally a concern in the aircraft operating environment. Rather, a common source of burst errors arises from the possibility of signals arriving from multiple aircraft at the same time. These types of burst

errors, called FRUIT, are to be incorporated into the simulation model. The validation portion of the research will be completed based on testing for correction of these error types.

At 3:20, Zoran Sevarlic began describing his work on the correction of phase errors with autofocus techniques. The work stems from the fact that a certain frequency spectrum useful in identifying a signal source becomes blurred due to aircraft motion. The autofocus techniques of interest are ways of correcting for second and third order terms in the Doppler shift of the frequency, as the signal is clear when only linear terms are present. This work is in an early state, but appears promising. Similar work has been done at AFRL, and Nick Pequignot recommended that efforts be made to communicate with those who have been involved in earlier efforts. Earlier efforts to reach the appropriate parties had not yet yielded any fruitful contact.

At 4:20, Bill Elliot began his presentation on a modified near-field technique for supporting the phased array antenna system. Bill noted that lack of equipment in the field limits the capability to detect failures in individual antenna elements. Bill has found that faults can be detected by constructing characteristic plots of the return when one element is presumed to have failed. When sufficient differences are noticed between such plots and a baseline signature, the faulty element can be detected. The data gathered thus far indicates this to be a useful approach to enhancing the testing capability with no significantly increased dedication of test equipment.

During the discussion period, for the benefit of the visiting scholars, Nick Pequignot described some of the emphases of the program in more detail than had been presented earlier. He encouraged them to visit AFRL and indicated he would be glad to provide any additional help that might be needed. He commented further in regard to the communication in regard to the phase correction problem. Tom Bass committed to follow through on this matter. The meeting was adjourned at 5:00 p.m.

5.1.2 Agenda

AGENDA

RAPCEval Steering Committee Meeting

Thursday, May 3, 2001 - 13:30 P.M.

Mercer Engineering Research Center
135 Osigian Boulevard, Warner Robins, Georgia 31088

Renew Acquaintances - Refreshments	13:30
Welcome & Introductions - Dave Barwick	13:35
RAPCEval Program Overview - Tom Bass	13:40
Student Presentations	
Houston Jones - <i>Error Correction in a Multipath Environment</i>	13:50
Mark Napier - <i>Application of Reed-Solomon Encoding to Improve Proposed Collision Avoidance System Based on Civilian ATCRBS</i>	14:20
Break (non-cleared personnel to go on MERC tour)	14:50
Zoran Sevarlic - <i>Use of Auto-focus Techniques in the Correction of Phase Errors in Radar Signals</i>	15:00
Break (non-cleared personnel return for 15:40 talk)	15:30
Bill Elliott - <i>A Modified Near-Field Technique for Supporting Phased Array Antenna Systems</i>	15:40
Discussions & New Business - Tom Bass	16:10
Adjournment	16:45

5.1.3 Attendance Roster

The attendees for this meeting, together with their organizations and contact information, are listed in Table 1.

Table 1. RAPCEval Attendance Roster – May 3, 2001, MERC

#	Name	Organization	Phone	Email Address
1	Tom Bass	MERC	478-953-6800	bass_wt@mercer.edu
2	Houston Jones	Advent (LR)	478-926-8207	houston.jones@robins.af.mil
3	Charles Bass	MERC	478-953-6800	cbass@merc.mercer.edu
4	Skip Finnigan	MERC	478-953-6800	sfinnigan@merc.mercer.edu
5	Mark Napier	Scientific Atlanta	770-236-6980	mark.napier@sciatl.com
6	Phil Oliver	WR-ALC/LNERT	478-926-2588	phil.oliver@robins.af.mil
7	C Arthur Crowell	WR-ALC/LNERT	478-926-2588	arthur.crowell@robins.af.mil
8	Legand Burge	Tuskegee Univ.	334-727-8355	lburge@tusk.edu
9	Behnam Kamali	Mercer Univ.	478-301-2415	kamali_b@mercer.edu
10	Nick Pequignot	AFRL/SNRP	937-255-6127 x4235	nicholas.pequignot@wpafb.af.mil
11	James Hedge	AFRL/SNRP	937-255-6127 x4349	james.hedge@wpafb.af.mil
12	Heshmat Aglan	Tuskegee Univ.	334-727-8857	aglanh@tusk.edu
13	David T Barwick	MERC	478-953-6800	dbarwick@merc.mercer.edu
14	Paul E MacNeil	Mercer Univ.	478-301-2185	macneil_pe@mercer.edu
15	John Synder	CSA	478-328-3012	snyder125@home.com
16	Jack Tehan	MERC	941-575-4867	jtehan@isni.net
17	Jeng-Nan Juang	Mercer Univ.	478-301-2574	juang_jn@mercer.edu
18	Mark Campbell	WR-ALC	478-926-7716	mark.campbell@robins.af.mil
19	Zoran Sevarlic	WR-ALC	478-926-7718	zoran.sevarlic@robins.af.mil
20	Kevin Barnett	Mercer Univ.	478-301-2112	barnett_kd@mercer.edu
21	Douglas Moody	ARINC	478-322-4616	dmoody@arinc.com
22	Bill Elliott	WR-ALC/LYSTD	478-926-3359	bill.elliott1@robins.af.mil
23	Larry Grosberg	WR-ALC/LNERT	478-926-2588	lawrence.grosberg@robins.af.mil
24	Sammie Giles	Tuskegee Univ.	334-727-8995	giless@tusk.edu

5.1.4 Overview of the Program

An overview of the RAPCEval Program was presented at this meeting by Dr. Tom Bass, Chief Scientist at MERC.

It is reproduced on the next 11 pages.



**EW RECEIVER AND PROCESSING
CONCEPTS EVALUATION PROGRAM
(RAPCEval) OVERVIEW**

**May
2001**

RAPCEval STEERING COMMITTEE MEETING

1:30 P.M., May 3, 2001
Mercer Engineering Research Center



**EW RECEIVER AND PROCESSING
CONCEPTS EVALUATION PROGRAM
(RAPCEval) OVERVIEW**

**May
2001**

GENERAL INFORMATION

★ **Contracts:**

1. WR-ALC/AFRL #F09603-93-G-0012-0017
2. Veridian #F33615-99-D-1447, Subcontract
D00022-DSC0107
3. EWTA (EW Techniques Analysis) #F33615-
97-C-1103, Research Order #VI

★ **Contract Values and Dates:**

1. \$349,964 - end date 12 June, 2001
2. \$ 42,500 - end date: closed April 2001
3. \$ 60,000 - end date 14 February, 2002



EW RECEIVER AND PROCESSING CONCEPTS EVALUATION PROGRAM (RAPCEval) OVERVIEW

May
2001

PROGRAM STATUS

- ★ Graduate Research Joint Support:
by Mercer University, Air Force Research Lab
(Dayton), Warner Robins Air Logistics Center and
various industry contributors
- ★ Successful research projects:
master's degree completion by 15 RAPCEval
students
- ★ Ongoing research:
projects underway by 7 current graduate students



**EW RECEIVER AND PROCESSING
CONCEPTS EVALUATION PROGRAM
(RAPCEval) OVERVIEW**

**May
2001**

PROGRAM STATUS

- ★ RAPCEval Research is *Useful*:
all research is approved by the project steering committee to be of value to the Air Force
- ★ RAPCEval Research upholds *Academic Credentials*:
the university and the student's graduate committee approves the research



**EW RECEIVER AND PROCESSING
CONCEPTS EVALUATION PROGRAM
(RAPCEval) OVERVIEW**

**May
2001**

PROGRAM RESEARCH STANDARDS COMMITTEE MEMBERS

★ **AF RESEARCH LAB**
Nick Pequignot (PM)
Aaron Linn
Emil R. Martinsek
Norman A. Toto
Duane A. Warner

★ **WR-ALC**
Steve Strawn (PM)
Phil Oliver
Ches Rehburg
Larry Sheets
TBD

★ **MERCER UNIVERSITY**
Aaron Collins
Behnam Kamali
Paul MacNeil

★ **MERC**
David Barwick (Chmn)
Tom Bass (PM)



EW RECEIVER AND PROCESSING CONCEPTS EVALUATION PROGRAM (RAPCEval) OVERVIEW

May
2001

Graduates & References to Reports

1. *Mark Astin*, "Application of Parallel Computing Techniques to the RAD Algorithm," (classified) AFRL-SN-WP-TR-1998-1088
2. *Henderson Benjamin*, "Selection of Reed Solomon Codes Using Neural Networks," AFRL-SN-WP-TR-1998-1056, p. 131
3. *Steve Boswell*, "AAR-47 Missile Warning Signal Analysis via Fuzzy Logic and Neural Networks," forthcoming report, Summer 2001
4. *Ron Brinkley*, "Burst Error Correction with Reed-Solomon Codes," AFRL-SN-WP-TR-1999-1115, p. 254



EW RECEIVER AND PROCESSING CONCEPTS EVALUATION PROGRAM (RAPCEval) OVERVIEW

May
2001

Graduates & References to Reports

5. *Peter Bryant*, "Rotational Doppler Algorithm Development,"
patent pending
6. *Mark Campbell*, "Auto-Regressive Spectral Analysis - EW
Applications," WL-TR-94-1057
7. *Randy Ford*, "Passive Location via Evolutionary Genetic
Algorithms," AFRL-SN-WP-TR-2000-1085
8. *Claus Franzkowiak*, "Four-Pulse Primary RAD Filter
Development," (classified) AFRL-SN-WP-TR-1998-1087



EW RECEIVER AND PROCESSING CONCEPTS EVALUATION PROGRAM (RAPCEval) OVERVIEW

May
2001

Graduates & References to Reports

9. *Neal Garner*, "Error Correction and Prediction for Improved Communication of Time and Time Measurements," WL-TR-96-1161
10. *Joseph Kelley*, "A Parameter Determination Alternative for RAD Analysis," (classified) WL-TR-95-1005
11. *Joseph Kelley*, "MultiGroup Simultaneous RAD Parameter Selection," (classified) WL-TR-97-1094
12. *Max Roesel*, "Agile RF/PRI Radar Analysis via RAD," (classified) WL-TR-95-1020



EW RECEIVER AND PROCESSING CONCEPTS EVALUATION PROGRAM (RAPCEval) OVERVIEW

May
2001

Graduates & References to Reports

13. *Dave Schuler*, "Comparison of Algorithms for Geolocation of Radar Signals," WL-TR-96-1161
14. *Tracy Tillman*, "Hardware Implementation for an Advanced Pulse Processing Algorithm," (classified), AFRL-SN-WP-TR-1998-1085
15. *Kirk Wright*, "Object-Oriented Modeling of the AN/ALQ-172," (classified) AFRL-SN-WP-TR-1998-1086



**EW RECEIVER AND PROCESSING
CONCEPTS EVALUATION PROGRAM
(RAPCEval) OVERVIEW**

**May
2001**

TODAY'S STUDENT PRESENTATIONS

- ★ *Houston Jones* – “Error Correction in a Multipath Environment”
- ★ *Mark Napier* – “ Application of Reed-Solomon Encoding to Improve Proposed Collision Avoidance System Based on Civilian ATCRBS”
- ★ *Zoran Sevarlic* – “Use Of Autofocus Techniques In The Correction Of Phase Errors In Radar Signals”
- ★ *Bill Elliott* – “Use of Autofocus Techniques in the Correction of Phase Errors in Radar Signals”



**EW RECEIVER AND PROCESSING
CONCEPTS EVALUATION PROGRAM
(RAPCEval) OVERVIEW**

**May
2001**

CURRENT STUDENT RESEARCH

1. *Bill Elliott* – Near-field Phase-Array Antenna
2. *Kerwin Holmes* - GPS Enhancement
3. *Houston Jones* – Multipath Error Correction
4. *Mark Napier* - IFF Improvement
5. *Zoran Sevarlic* – Radar Phase Processing Improvements
6. *John Snyder* – Radar Phase Processing – Genetic Approach
7. *Wes Stinehelfer* - GPS Wavelet Processing

5.1.5 Presentation by Houston Jones

The student briefing presented by Houston Jones at this meeting is reproduced on the next 39 pages.



**EW RECEIVER AND PROCESSING
CONCEPTS EVALUATION PROGRAM
(RAPCEval)**

Houston Jones
MSEE Program
Final

RESEARCH PROGRESS REPORT

Houston Jones
WR-ALC/LR
System Engineer

Date Approved: October 1998

Projected Completion Date: July 2001

Research Topic:

ERROR CORRECTION IN A MULTIPATH FADING ENVIRONMENT



**EW RECEIVER AND PROCESSING
CONCEPTS EVALUATION PROGRAM
(RAPCEval)**

Houston Jones
MSEE Program
Final

RESEARCH PROGRESS REPORT

Houston Jones

WRALC/LR
System Engineer

Background and Experience:

Education: BS from Jacksonville State University(Mathematics)

BEE from Auburn University

MSA from Georgia College (Management)

Pursuing MSE with emphasis in Electrical Engineering- 29 semester hours completed

WR/ALC: U2 Management Directorate

Research Topic: ERROR CORRECTION IN A MULTIPATH FADING ENVIRONMENT



**EW RECEIVER AND PROCESSING
CONCEPTS EVALUATION PROGRAM
(RAPCEval)**

Houston Jones
MSEE Program
Final

ERROR CORRECTION IN A MULTIPATH FADING ENVIRONMENT

PROBLEM STATEMENT

Wireless communication systems operate in an environment that causes fast envelope fluctuation relative to that of the expected value of the received signal. In this environment, reflecting objects and objects in motion can cause the received signal to fade. Fading induces errors that, if not corrected, can cause the received signal to differ from the transmitted signal.



**EW RECEIVER AND PROCESSING
CONCEPTS EVALUATION PROGRAM
(RAPCEval)**

Houston Jones
MSEE Program
Final

ERROR CORRECTION IN A MULTIPATH FADING ENVIRONMENT

RESEARCH OBJECTIVES

Evaluate the performance of a QPSK modulated signal with no error correcting codes in a multipath fading environment

Investigate the performance of a QPSK modulated signal with various error correcting codes in a multipath fading environment

Block Code

Convolutional Code

Concatenated Code

Evaluate IS 95 CDMA signal in a multipath fading environment



**EW RECEIVER AND PROCESSING
CONCEPTS EVALUATION PROGRAM
(RAPCEval)**

Houston Jones
MSEE Program
Final

ERROR CORRECTION IN A MULTIPATH FADING ENVIRONMENT

Major Accomplishments

Received ACOLADE simulation software
Modeled IS 95 CDMA Reverse Channel

- No error control codes and AWGN channel
- Convolutional error control codes and AWGN channel
- No error control codes and multipath channel
- Convolutional error control codes and multipath channel

Modified models to find simulation that is “workable”



**EW RECEIVER AND PROCESSING
CONCEPTS EVALUATION PROGRAM
(RAPCEval)**

Houston Jones
MSEE Program
Final

ERROR CORRECTION IN A MULTIPATH FADING ENVIRONMENT

Major Accomplishments (cont.)

Modeled QPSK Modulated Signal

- Reed-Solomon Error Control Coding and AWGN channel
- Reed-Solomon Error Control Coding and multipath channel
- Convolutional Error Control Coding and AWGN channel
- Convolutional Error Control Coding and multipath channel
- Concatenated Error Control Coding and AWGN channel
- Concatenated Error Control Coding and multipath channel



**EW RECEIVER AND PROCESSING
CONCEPTS EVALUATION PROGRAM
(RAPCEval)**

Houston Jones
MSEE Program
Final

ERROR CORRECTION IN A MULTIPATH FADING ENVIRONMENT

Major Accomplishments (cont.)

Modeled IS 95 CDMA Reverse Channel

Convolutional error control codes and AWGN channel

Convolutional error control codes and multipath channel



**EW RECEIVER AND PROCESSING
CONCEPTS EVALUATION PROGRAM
(RAPCEval)**

Houston Jones
MSEE Program
Final

ERROR CORRECTION IN A MULTIPATH FADING ENVIRONMENT

Technical Overview and Progress Achieved

Fading -- small scale fading

Time Spreading due to multipath

Flat Fading -- multipath delay spread is less than symbol time
Frequency Selective Fading -- multipath delay spread is
greater than symbol time

Time Variant due to motion (Doppler Spread)

Fast Fading -- Channel fading rate is greater than symbol rate
Slow Fading -- Channel fading rate is less than symbol rate



**EW RECEIVER AND PROCESSING
CONCEPTS EVALUATION PROGRAM
(RAPCEval)**

Houston Jones
MSEE Program
Final

ERROR CORRECTION IN A MULTIPATH FADING ENVIRONMENT

Technical Overview and Progress Achieved

Research areas (Complete)

Error control codes

Performance analysis in Rayleigh environment

Block codes

Reed Solomon codes (255,223)

Convolutional codes

Rate 1/2, constraint length 7

Concatenated codes

Reed Solomon codes + Convolutional codes

Convolutional Code (IS 95)

Rate 1/3, constraint length 9



EW RECEIVER AND PROCESSING CONCEPTS EVALUATION PROGRAM (RAPCEval)

Houston Jones
MSEE Program
Final

ERROR CORRECTION IN A MULTIPATH FADING ENVIRONMENT

Reed-Solomon Codes

Encoder takes a block of data and adds redundant or parity bits, these bits are used by the receiver to detect and correct transmission errors.

Code length is $n = 2^m - 1$ in symbols each of m bits

m is the word length in bits

random error correcting capability in symbols $t = (n - k)/2$ $2t = n - k$

number of data symbols $k = n - 2t$

number of parity symbols is $n - k$, (code length - number of data symbols)

Code Rate $R_c = k/n$

Symbol Error -- One symbol error occurs when 1 bit is wrong or any number of bits including all the bits in a symbol are wrong



EW RECEIVER AND PROCESSING
CONCEPTS EVALUATION PROGRAM
(RAPCEval)

Houston Jones
MSEE Program
Final

ERROR CORRECTION IN A MULTIPATH FADING ENVIRONMENT
Reed-Solomon Codes

Burst Error Correction

Reed-Solomon codes have the capability to correct burst errors of length equal to t consecutive symbols

Maximum guaranteed error correction capability

Single burst $b = m(t - 1) + 1$

Double burst $b = m[\lfloor t/2 \rfloor - 1] + 1$

Triple burst $b = m[\lfloor t/3 \rfloor - 1] + 1$



EW RECEIVER AND PROCESSING CONCEPTS EVALUATION PROGRAM (RAPCEval)

Houston Jones
MSEE Program
Final

ERROR CORRECTION IN A MULTIPATH FADING ENVIRONMENT Convolutional Codes

Generated by passing the information sequence through a binary shift register

Decoded using the Viterbi algorithm

A maximum-likelihood decoder

It identifies the code sequence with the highest probability of matching the transmitted sequence based on the received sequence

Soft-decision decoding can give a coding gain of 2 to 3 dB over the hard-decision Viterbi decoder over an additive white Gaussian noise channel. A performance increase of 9 dB is possible on fading channels



**EW RECEIVER AND PROCESSING
CONCEPTS EVALUATION PROGRAM
(RAPCEval)**

Houston Jones
MSEE Program
Final

**ERROR CORRECTION IN A MULTIPATH FADING ENVIRONMENT
Convolutional Codes**

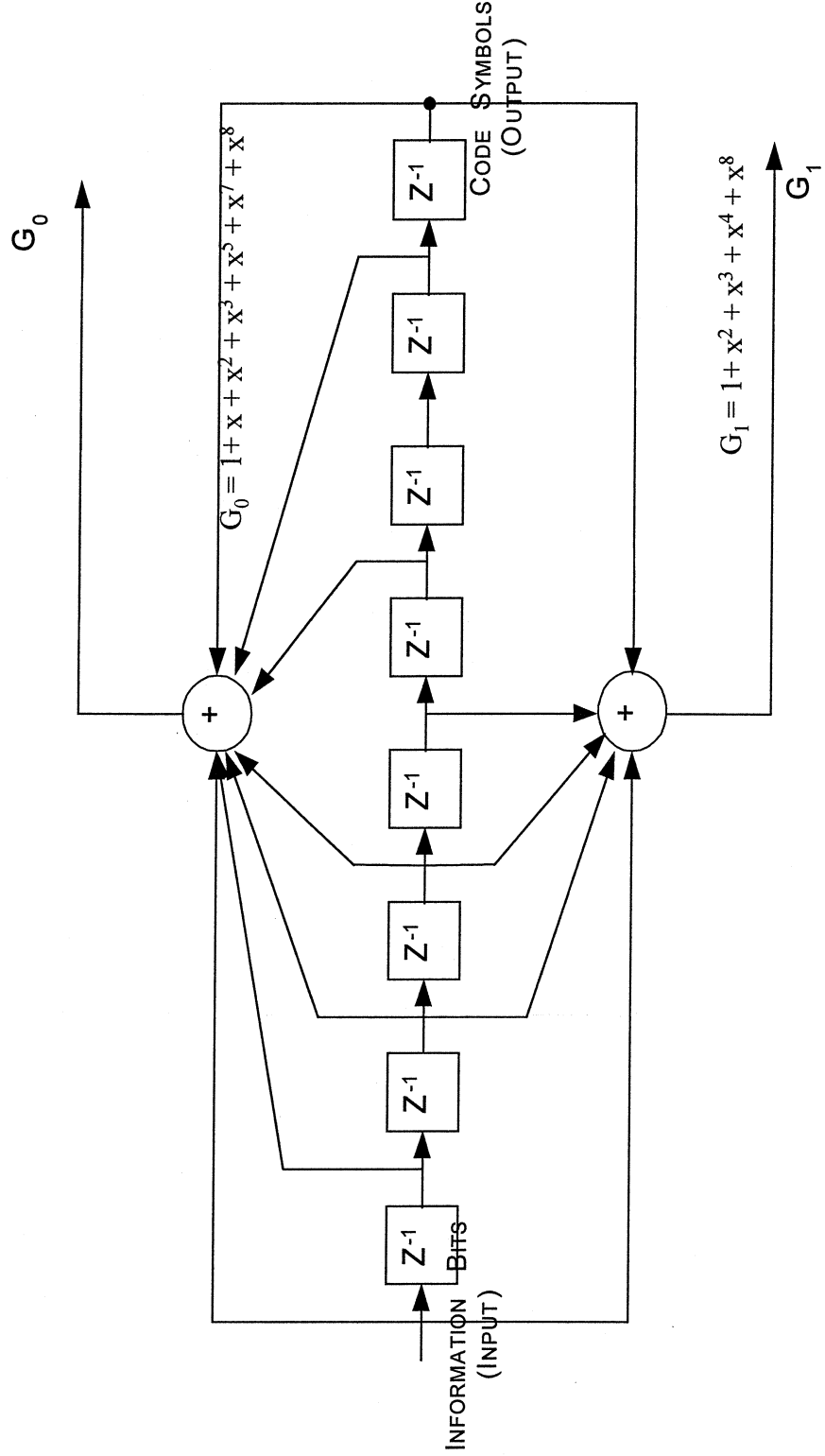



EW RECEIVER AND PROCESSING
CONCEPTS EVALUATION PROGRAM
(RAPCEval)

Houston Jones
MSEE Program
Final

ERROR CORRECTION IN A MULTIPATH FADING ENVIRONMENT

Simulation Results

<i>Channel Modulation</i>	<i>Coding</i>	<i>SNR(dB) for BER = 1×10^{-5}</i>	<i>Coding Gain(dB) at BER = 1×10^{-5}</i>
AWGN	QPSK	None	9.6
		Reed-Solomon	7.5
		Convolutional	5.0
		Concatenated	3.8
IS 95		Convolutional	7.25
			2.1
			4.6
			5.8
			2.35



**EW RECEIVER AND PROCESSING
CONCEPTS EVALUATION PROGRAM
(RAPCEval)**

Houston Jones
MSEE Program
Final

ERROR CORRECTION IN A MULTIPATH FADING ENVIRONMENT

Simulation Results (Cont.)

<i>Channel</i>	<i>Modulation</i>	<i>Coding</i>	<i>SNR(dB) for BER = 1X10⁻⁵</i>	<i>Coding Gain (dB) at BER = 1X10⁻⁵</i>
Rayleigh	QPSK	None		
	Doppler = Low		7.3	-
	Doppler = Med		14.6	-
	Doppler = High		16	-
Reed-Solomon				
	Doppler = Low		14.15	3.15
	Doppler = Med		12.2	2.4
	Doppler = High		11.85	4.15



**EW RECEIVER AND PROCESSING
CONCEPTS EVALUATION PROGRAM
(RAPCEval)**

Houston Jones
MSEE Program
Final

ERROR CORRECTION IN A MULTIPATH FADING ENVIRONMENT

Simulation Results (Cont.)

<i>Channel</i>	<i>Modulation</i>	<i>Coding</i>	<i>SNR(dB) for BER = 1X10⁻⁵</i>	<i>Coding Gain(dB) at BER = 1X10⁻⁵</i>
Rayleigh	QPSK			
Convolutional [1/2, 7]				
	Doppler = Low		10	7.3
	Doppler = Med		7.65	6.95
	Doppler = High		7.25	8.75



**EW RECEIVER AND PROCESSING
CONCEPTS EVALUATION PROGRAM
(RAPCEval)**

Houston Jones
MSEE Program
Final

ERROR CORRECTION IN A MULTIPATH FADING ENVIRONMENT

Simulation Results (Cont.)

<i>Channel Modulation</i>	<i>Coding</i>	<i>SNR(dB) for BER = 1×10^{-5} at BER = 1×10^{-5}</i>	<i>Coding Gain(dB)</i>
Rayleigh	QPSK		
	Concatenated		
	Doppler = Low	7.3	10
	Doppler = Med	6.5	8.1
	Doppler = High	7.2	8.8
IS 95	Convolutional [1/3, 9]		
	Doppler = Low	10.3	7
	Doppler = Med	10.1	4.5
	Doppler = High	8.9	6.5



**EW RECEIVER AND PROCESSING
CONCEPTS EVALUATION PROGRAM
(RAPCEval)**

Houston Jones
MSEE Program
Final

ERROR CORRECTION IN A MULTIPATH FADING ENVIRONMENT
Conclusions

Convolutional codes provide good BER performance and coding gain for noisy channels

Reed-Solomon codes provide good BER performance with moderate coding gain for noisy channels

Concatenated codes provided best BER performance and coding gain for noisy channels



EW RECEIVER AND PROCESSING CONCEPTS EVALUATION PROGRAM (RAPCEval)

Houston Jones
MSEE Program
Final

ERROR CORRECTION IN A MULTIPATH FADING ENVIRONMENT

Conclusions

Carefully selected error correcting codes can be used to improve performance of an uncoded bit stream transmitted over Gaussian and multipath channel

In general SNR required to achieve a BER of 1×10^{-5} decreases as Doppler frequency increases

Concatenated codes produced the best overall performance -- SNR required for a specified BER and coding gain

Reed-Solomon codes had the weakest multipath performance of the codes that were analyzed

IS 95 achieved the most consistent results over the range of multipath signals



**EW RECEIVER AND PROCESSING
CONCEPTS EVALUATION PROGRAM
(RAPCEval)**

Houston Jones
MSEE Program
Final

ERROR CORRECTION IN A MULTIPATH FADING ENVIRONMENT

Conclusions

Convolutional codes provide good BER performance and coding gain for noisy channels

Reed-Solomon codes provide good BER performance with moderate coding gain for noisy channels

Concatenated codes provided best BER performance and coding gain for noisy channels



**EW RECEIVER AND PROCESSING
CONCEPTS EVALUATION PROGRAM
(RAPCEval)**

Houston Jones
MSEE Program
Final

ERROR CORRECTION IN A MULTIPATH FADING ENVIRONMENT

Conclusions

Low SNR (< 4.5 dB) the convolutional and concatenated codes outperformed the Reed-Solomon code and the IS 95 system

Reed-Solomon code outperformed the IS 95 system < 5 dB



**EW RECEIVER AND PROCESSING
CONCEPTS EVALUATION PROGRAM
(RAPCEval)**

Houston Jones
MSEE Program
Final

ERROR CORRECTION IN A MULTIPATH FADING ENVIRONMENT

Contributions

Investigated and evaluated the performance of the following
error correcting codes --

Block Code--Reed-Solomon (255,223)

Convolutional Code -- Rate 1/2 Constraint Length 7

Concatenated Code --Reed-Solomon + Convolutional
Channels

AWGN

Fading

For each code investigated --

Wide range of multipath components

Wide range of Doppler frequencies



**EW RECEIVER AND PROCESSING
CONCEPTS EVALUATION PROGRAM
(RAPCEval)**

Houston Jones
MSEE Program
Final

ERROR CORRECTION IN A MULTIPATH FADING ENVIRONMENT
Additional Research Topics

Develop a software model to evaluate different error correcting codes in a cellular environment

Explore the use of turbo codes for application in a wireless environment

Define conditions for best use of different types of error correcting codes

Define codes and application

Block

Convolutional

Turbo

Concatenated

Multipath, space, cellular, CDs,



**EW RECEIVER AND PROCESSING
CONCEPTS EVALUATION PROGRAM
(RAPCEval)**

Houston Jones
MSEE Program
Final

ERROR CORRECTION IN A MULTIPATH FADING ENVIRONMENT

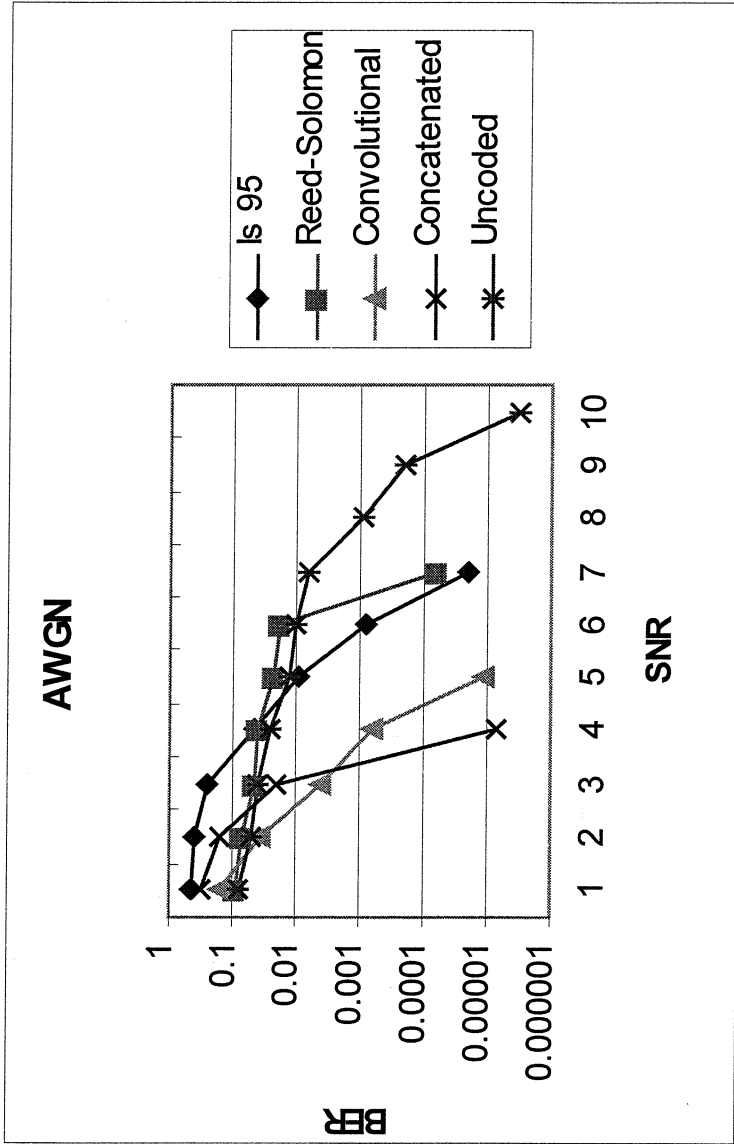

Coded and Uncoded Systems with AWGN Channel



**EW RECEIVER AND PROCESSING
CONCEPTS EVALUATION PROGRAM
(RAPCEval)**

Houston Jones
MSEE Program
Final

ERROR CORRECTION IN A MULTIPATH FADING ENVIRONMENT

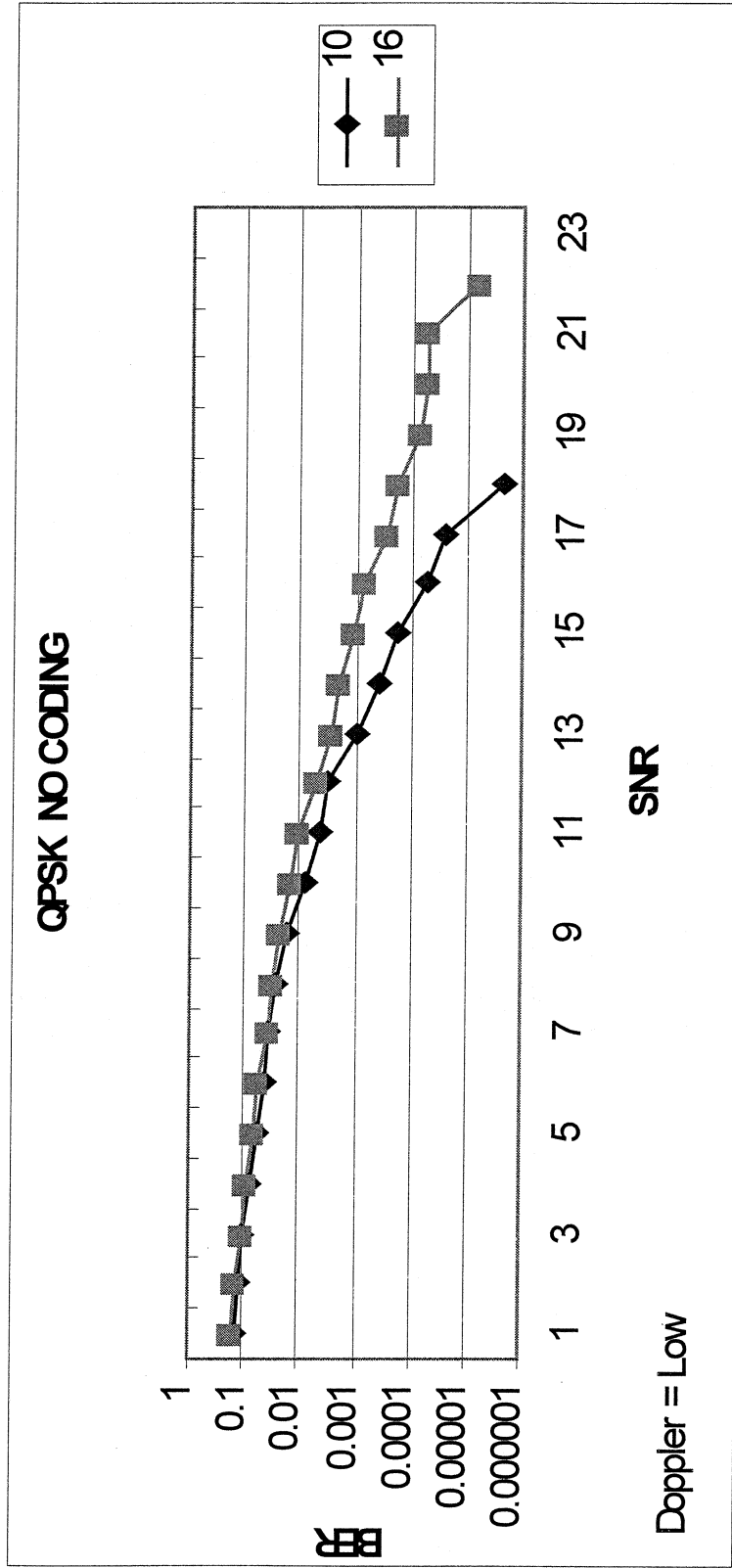

QPSK No Coding Doppler = Low



**EW RECEIVER AND PROCESSING
CONCEPTS EVALUATION PROGRAM
(RAPCEval)**

Houston Jones
MSEE Program
Final

ERROR CORRECTION IN A MULTIPATH FADING ENVIRONMENT

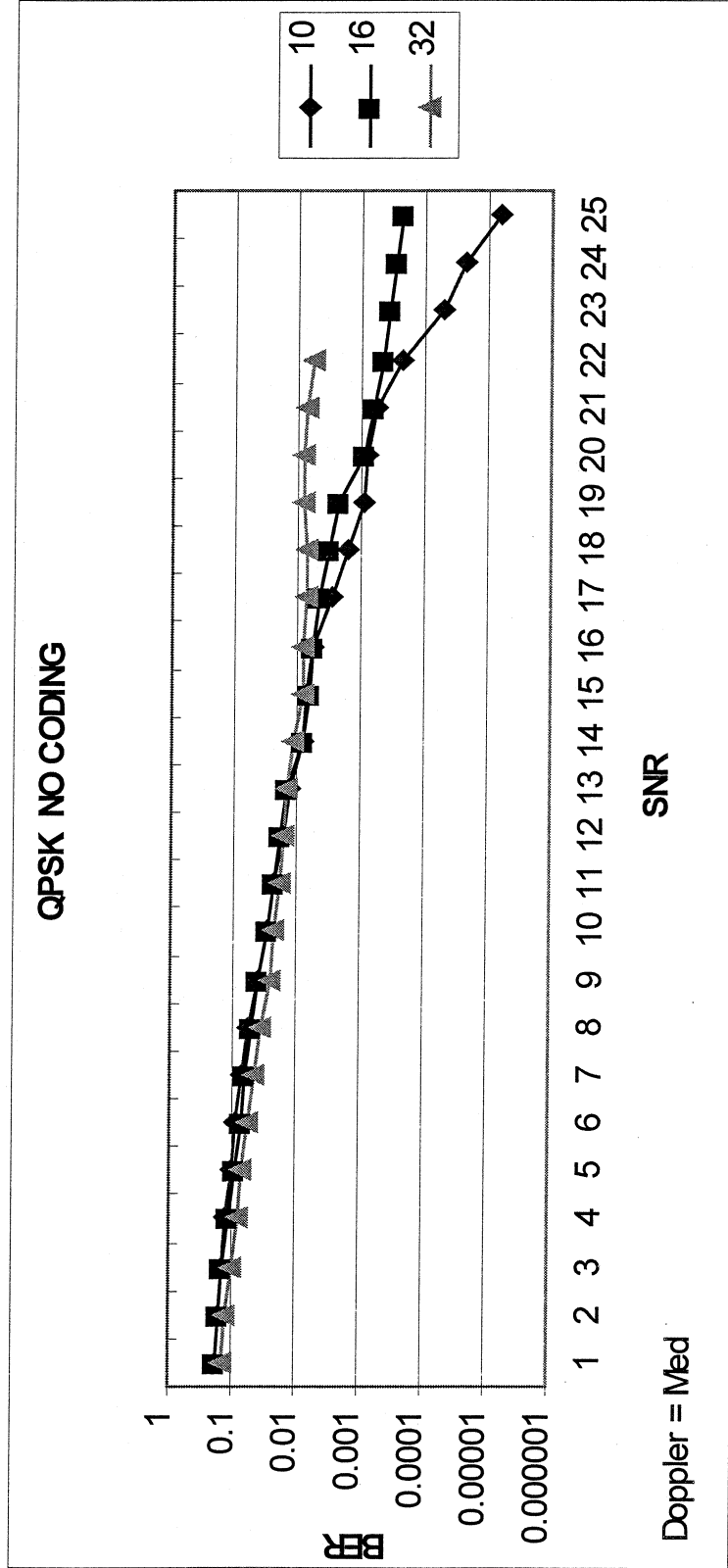



**EW RECEIVER AND PROCESSING
CONCEPTS EVALUATION PROGRAM
(RAPCEval)**

Houston Jones
MSEE Program
Final

ERROR CORRECTION IN A MULTIPATH FADING ENVIRONMENT

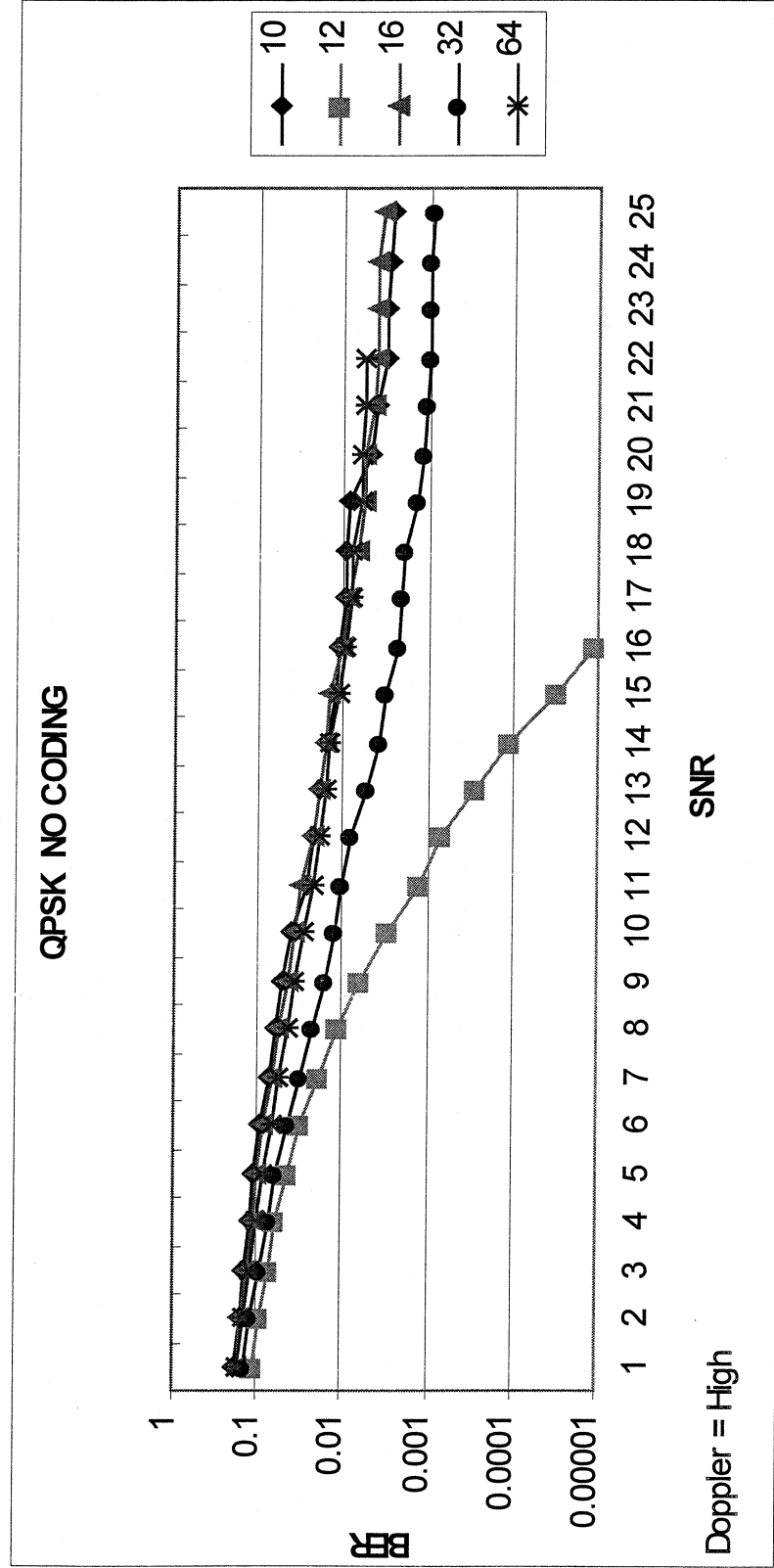

QPSK No Coding Doppler = High



EW RECEIVER AND PROCESSING CONCEPTS EVALUATION PROGRAM (RAPCEval)

Houston Jones
MSEE Program
Final

ERROR CORRECTION IN A MULTIPATH FADING ENVIRONMENT

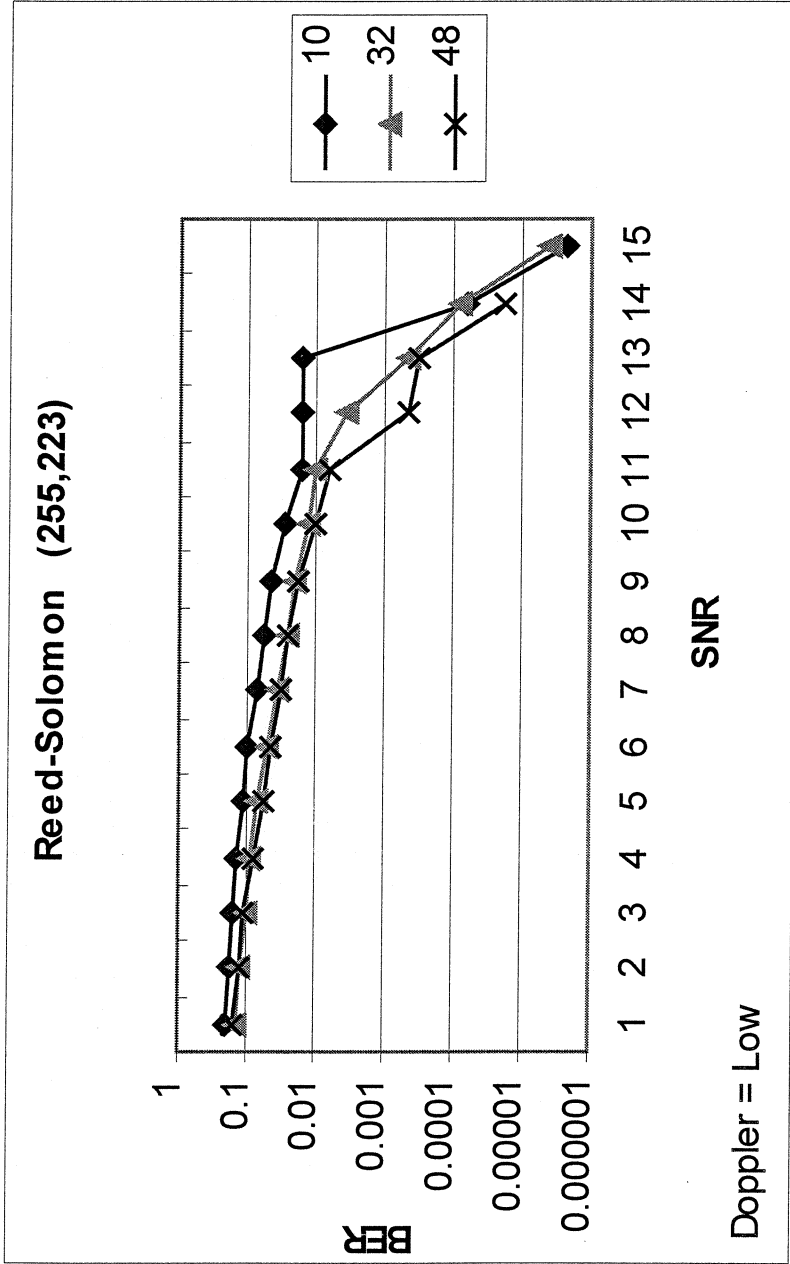

Reed-Solomon (255,223) Doppler = Low



**EW RECEIVER AND PROCESSING
CONCEPTS EVALUATION PROGRAM
(RAPCEval)**

Houston Jones
MSEE Program
Final

ERROR CORRECTION IN A MULTIPATH FADING ENVIRONMENT

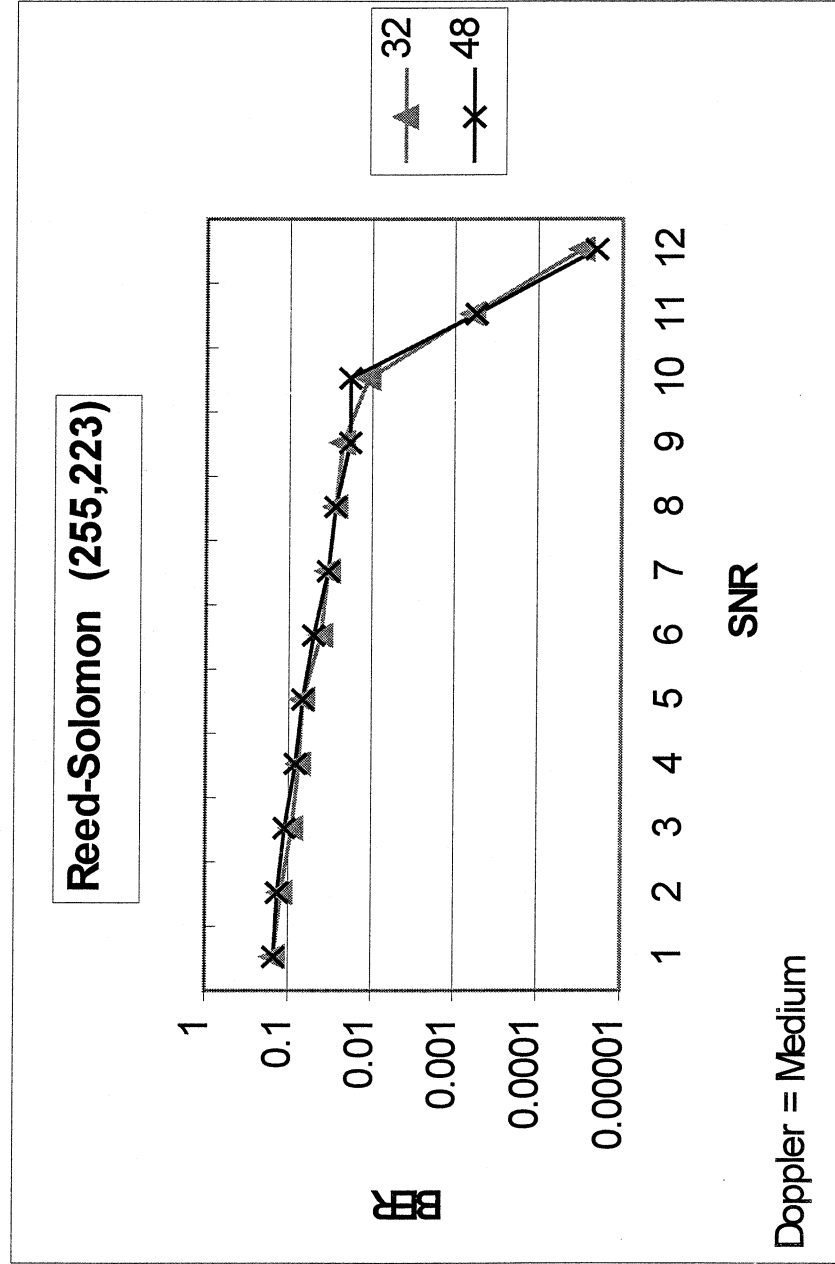



**EW RECEIVER AND PROCESSING
CONCEPTS EVALUATION PROGRAM
(RAPCEval)**

Houston Jones
MSEE Program
Final

ERROR CORRECTION IN A MULTIPATH FADING ENVIRONMENT

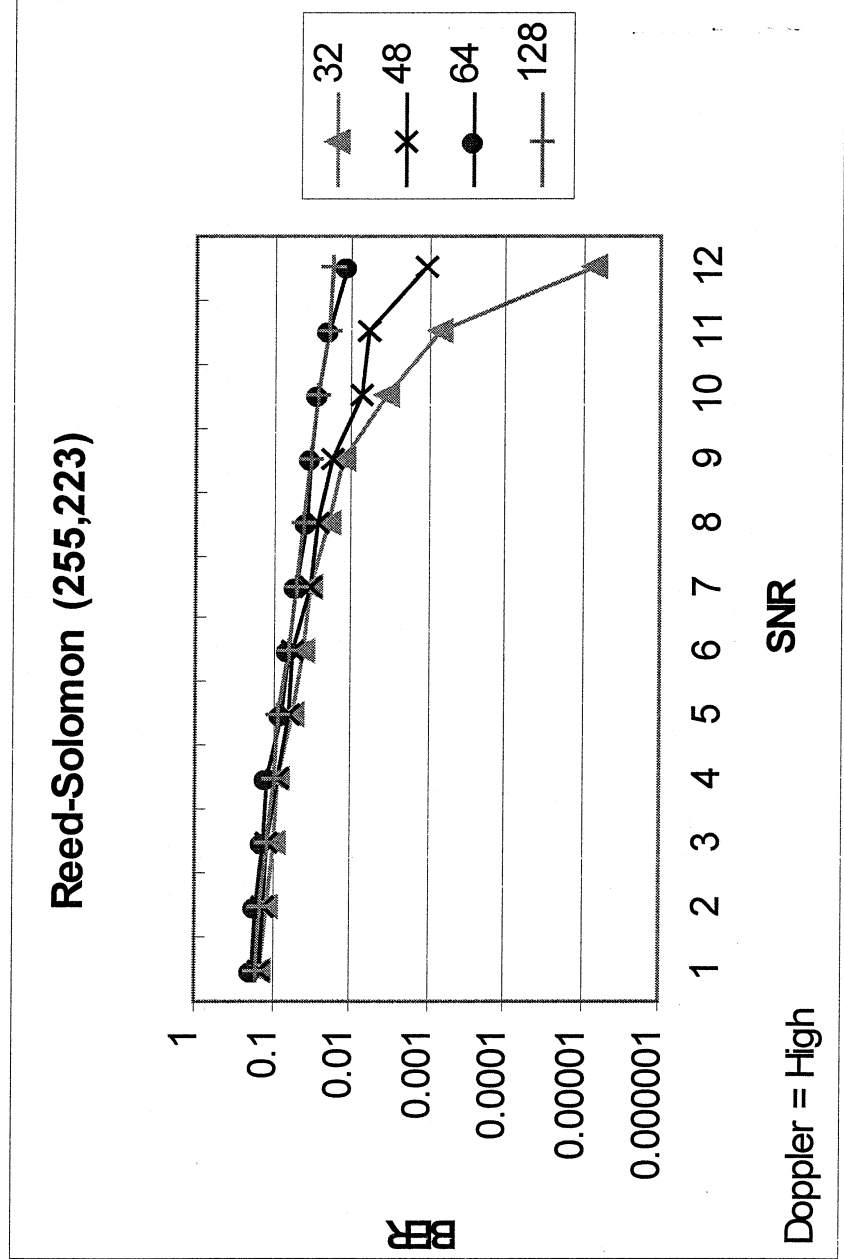

Reed-Solomon (255,223) Doppler = High



**EW RECEIVER AND PROCESSING
CONCEPTS EVALUATION PROGRAM
(RAPCEval)**

Houston Jones
MSEE Program
Final

ERROR CORRECTION IN A MULTIPATH FADING ENVIRONMENT

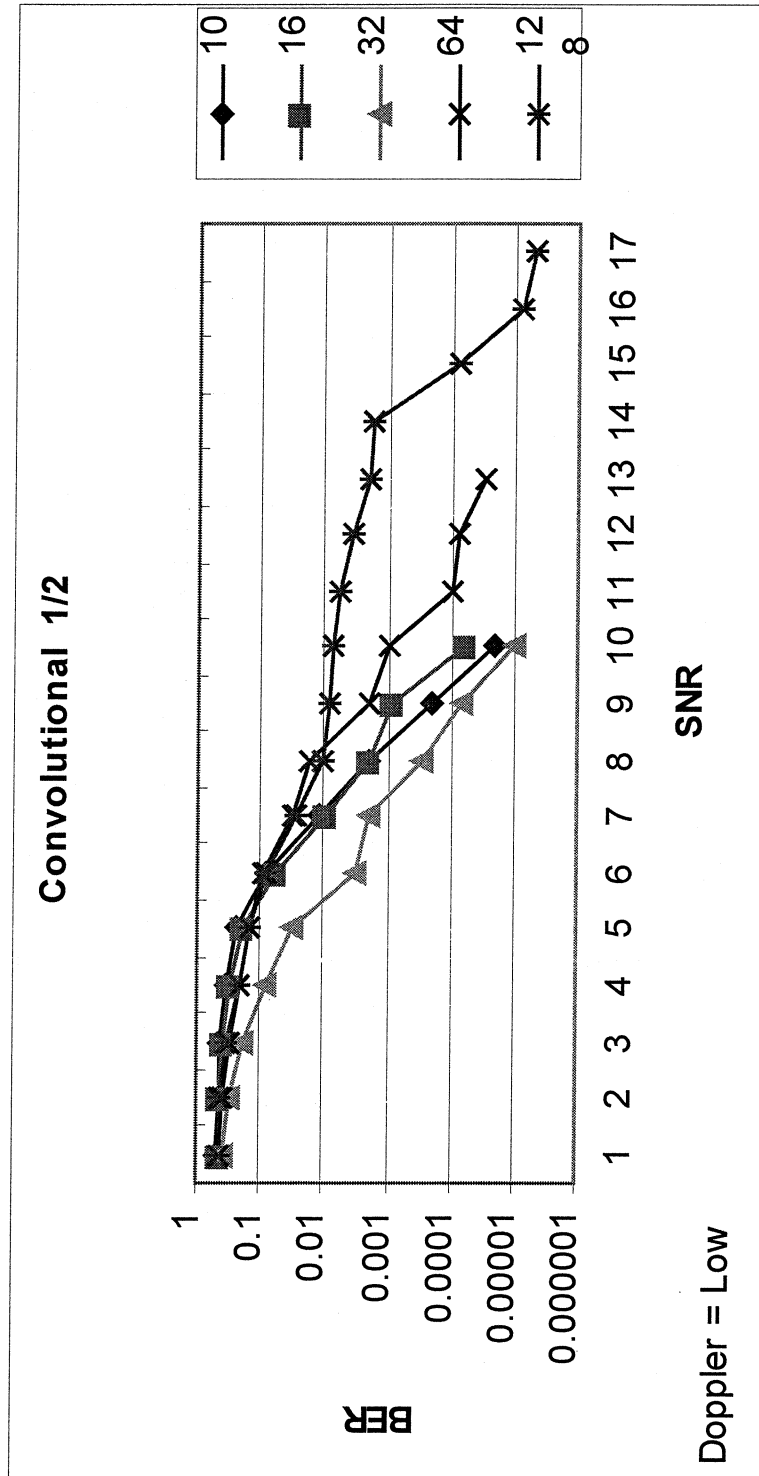

Convolutional Rate 1/2 Doppler = Low



**EW RECEIVER AND PROCESSING
CONCEPTS EVALUATION PROGRAM
(RAPCEval)**

Houston Jones
MSEE Program
Final

ERROR CORRECTION IN A MULTIPATH FADING ENVIRONMENT

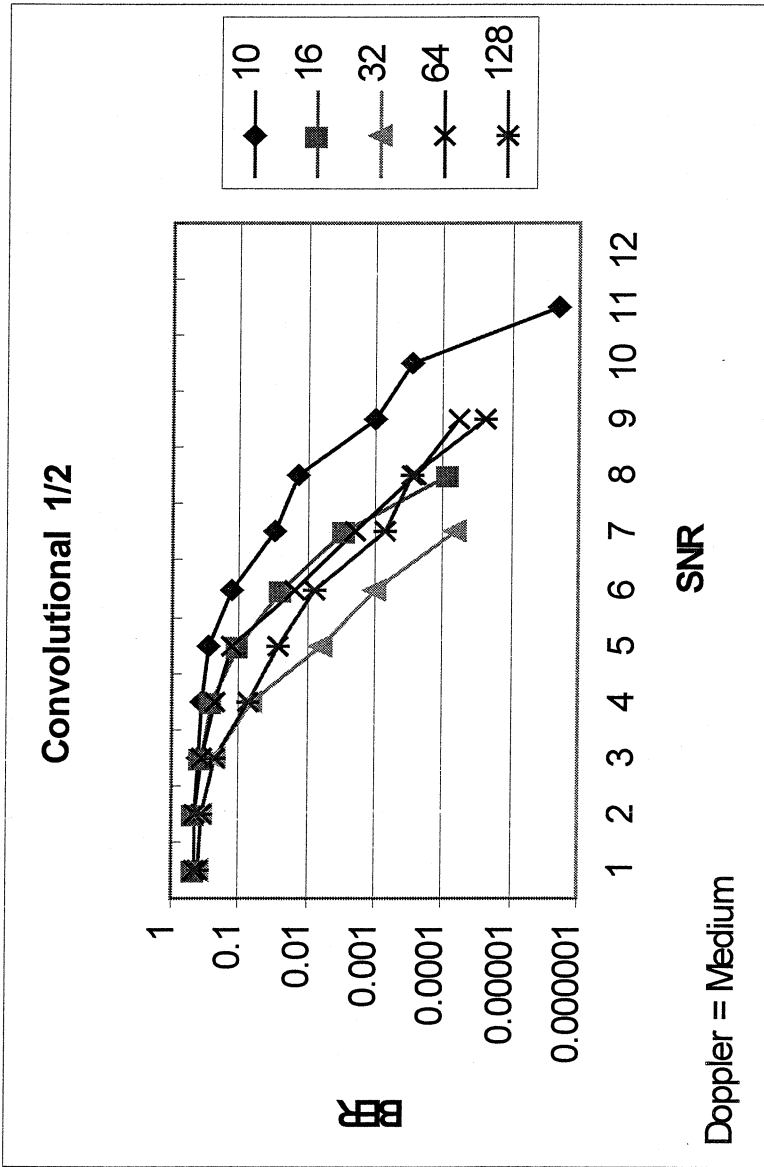



EW RECEIVER AND PROCESSING CONCEPTS EVALUATION PROGRAM (RAPCEval)

Houston Jones
MSEE Program
Final

ERROR CORRECTION IN A MULTIPATH FADING ENVIRONMENT

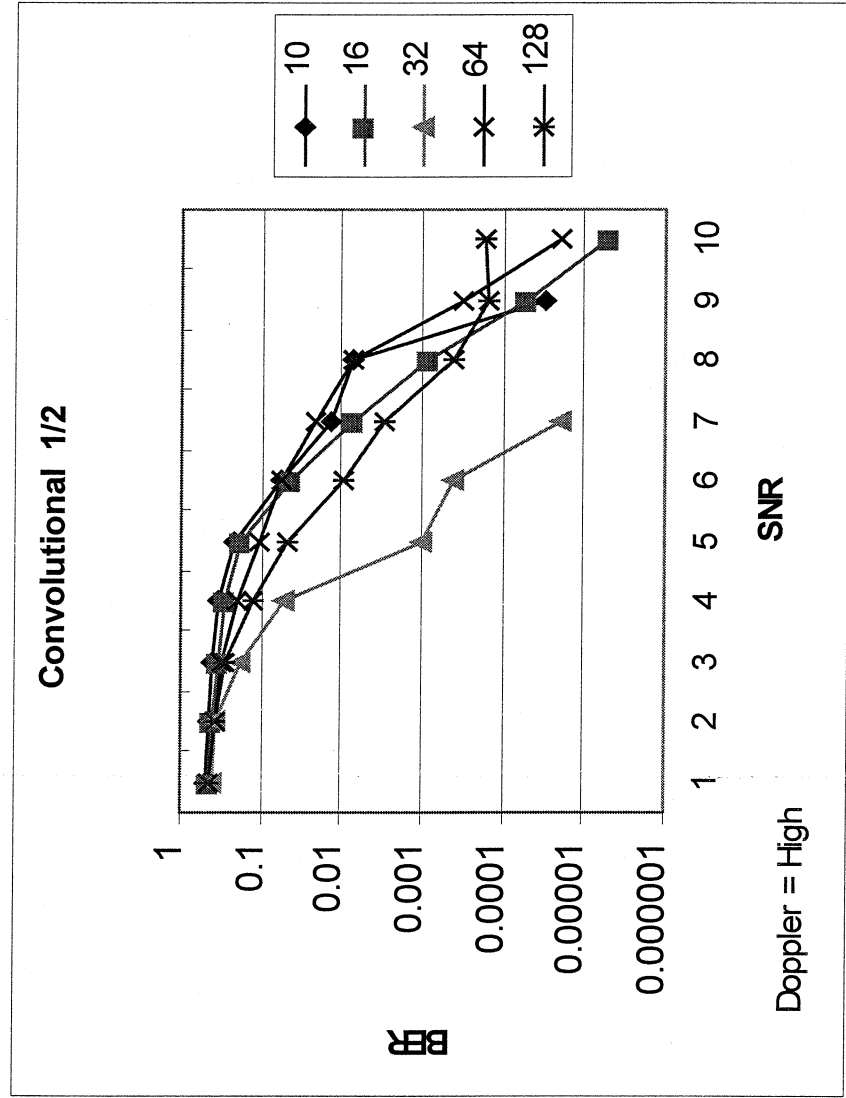



**EW RECEIVER AND PROCESSING
CONCEPTS EVALUATION PROGRAM
(RAPCEval)**

Houston Jones
MSEE Program
Final

ERROR CORRECTION IN A MULTIPATH FADING ENVIRONMENT

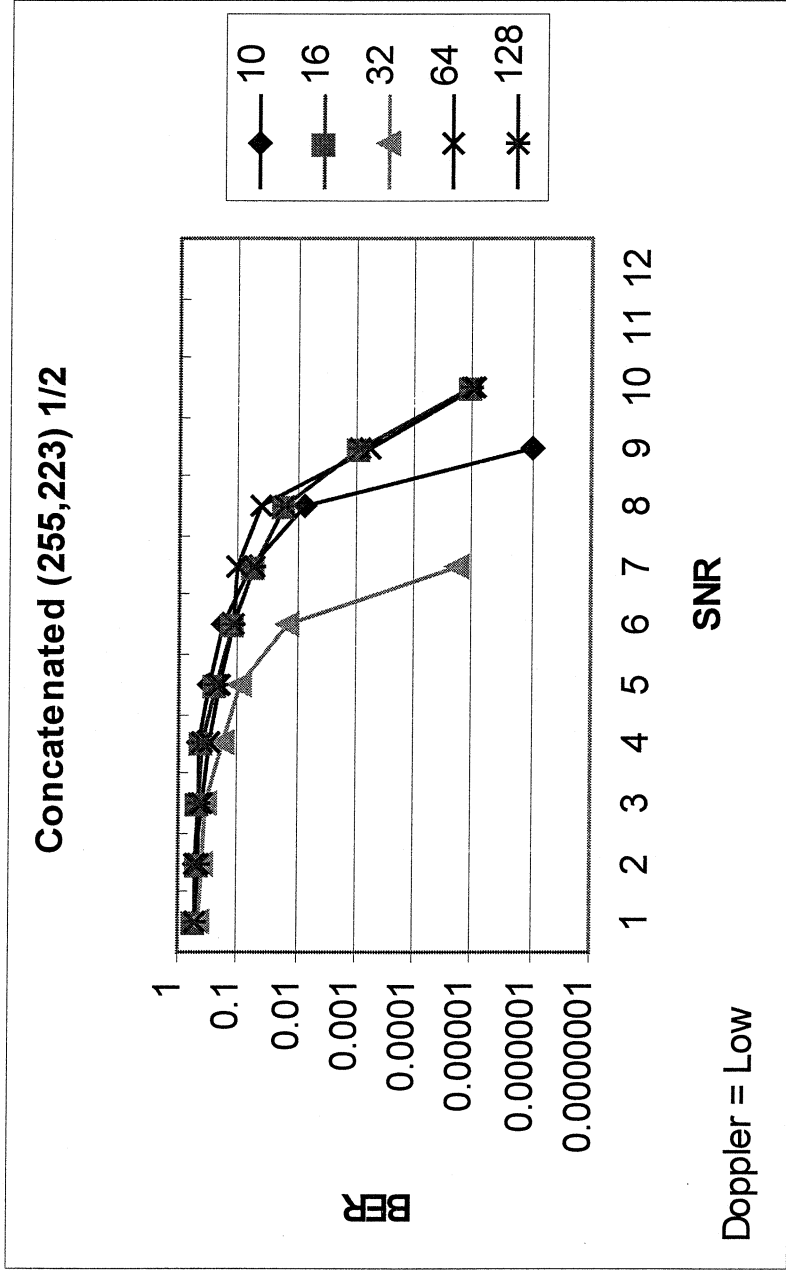

Concatenated RS (255,223) Convolutional 1/2 Doppler = Low



**EW RECEIVER AND PROCESSING
CONCEPTS EVALUATION PROGRAM
(RAPCEval)**

Houston Jones
MSEE Program
Final

ERROR CORRECTION IN A MULTIPATH FADING ENVIRONMENT

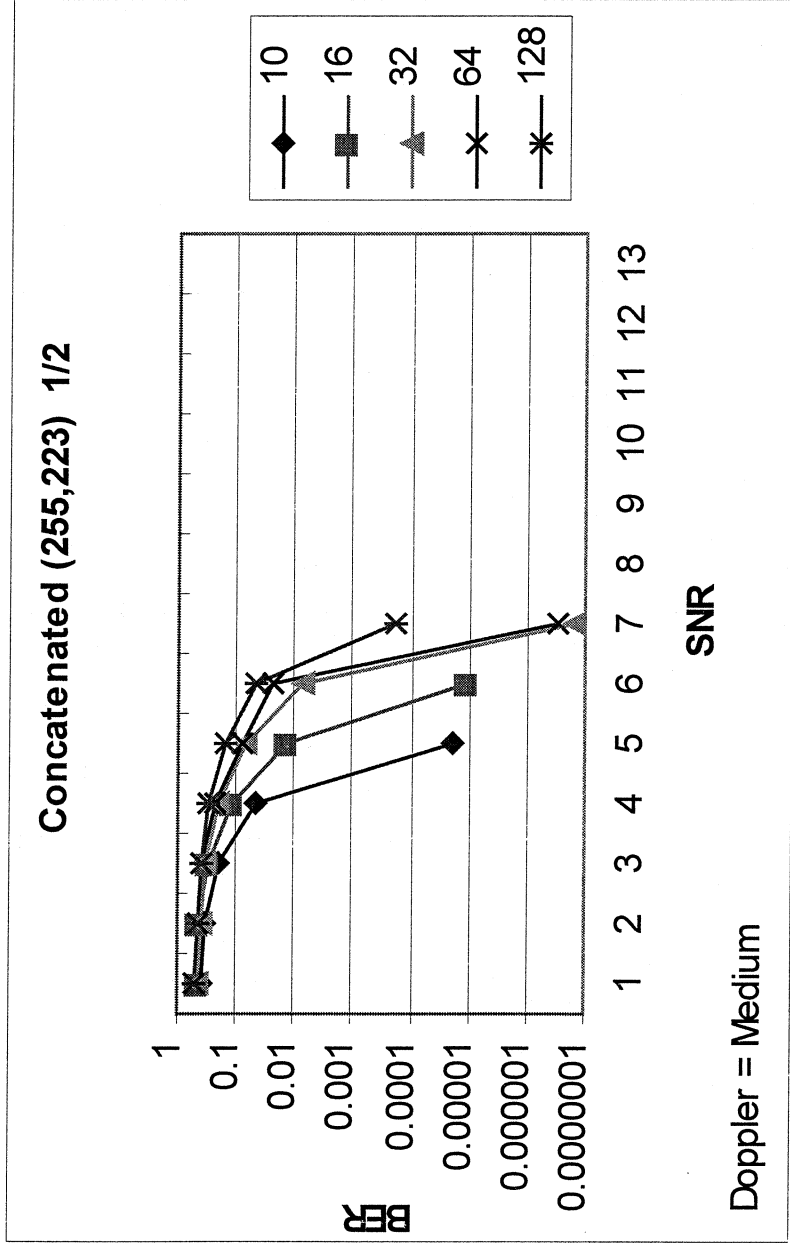

Concatenated RS (255,223) Convolutional 1/2 Doppler = Medium



**EW RECEIVER AND PROCESSING
CONCEPTS EVALUATION PROGRAM
(RAPCEval)**

Houston Jones
MSEE Program
Final

ERROR CORRECTION IN A MULTIPATH FADING ENVIRONMENT

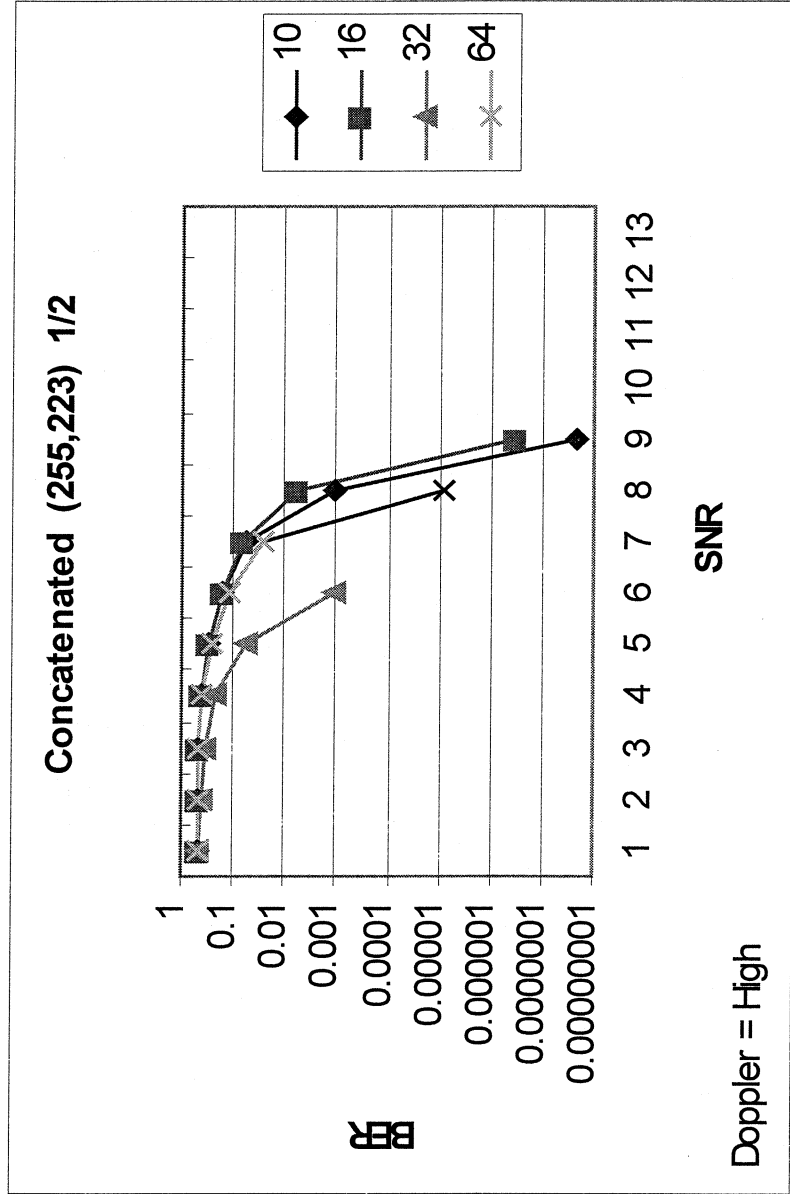

Concatenated RS (255,223) Convolutional 1/2 Doppler = High



**EW RECEIVER AND PROCESSING
CONCEPTS EVALUATION PROGRAM
(RAPCEval)**

Houston Jones
MSEE Program
Final

ERROR CORRECTION IN A MULTIPATH FADING ENVIRONMENT

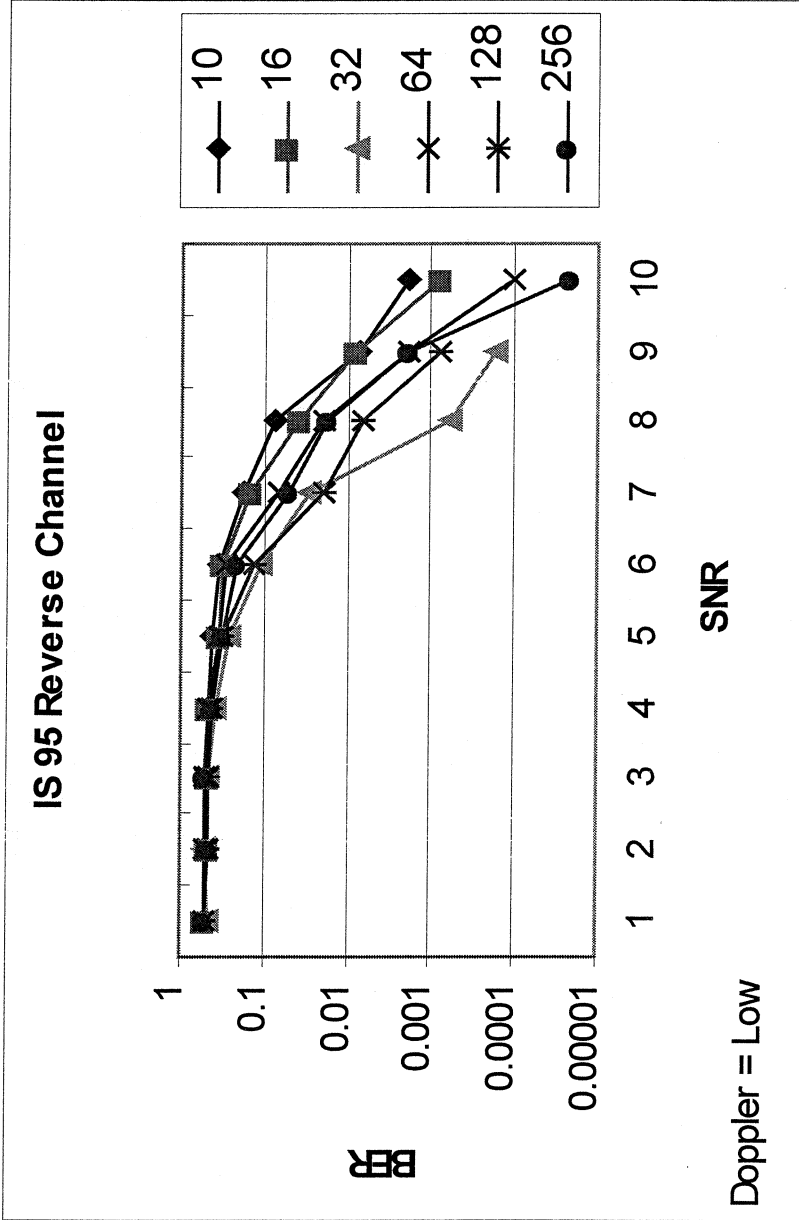

IS 95 Reverse Channel Doppler = Low



**EW RECEIVER AND PROCESSING
CONCEPTS EVALUATION PROGRAM
(RAPCEval)**

Houston Jones
MSEE Program
Final

ERROR CORRECTION IN A MULTIPATH FADING ENVIRONMENT

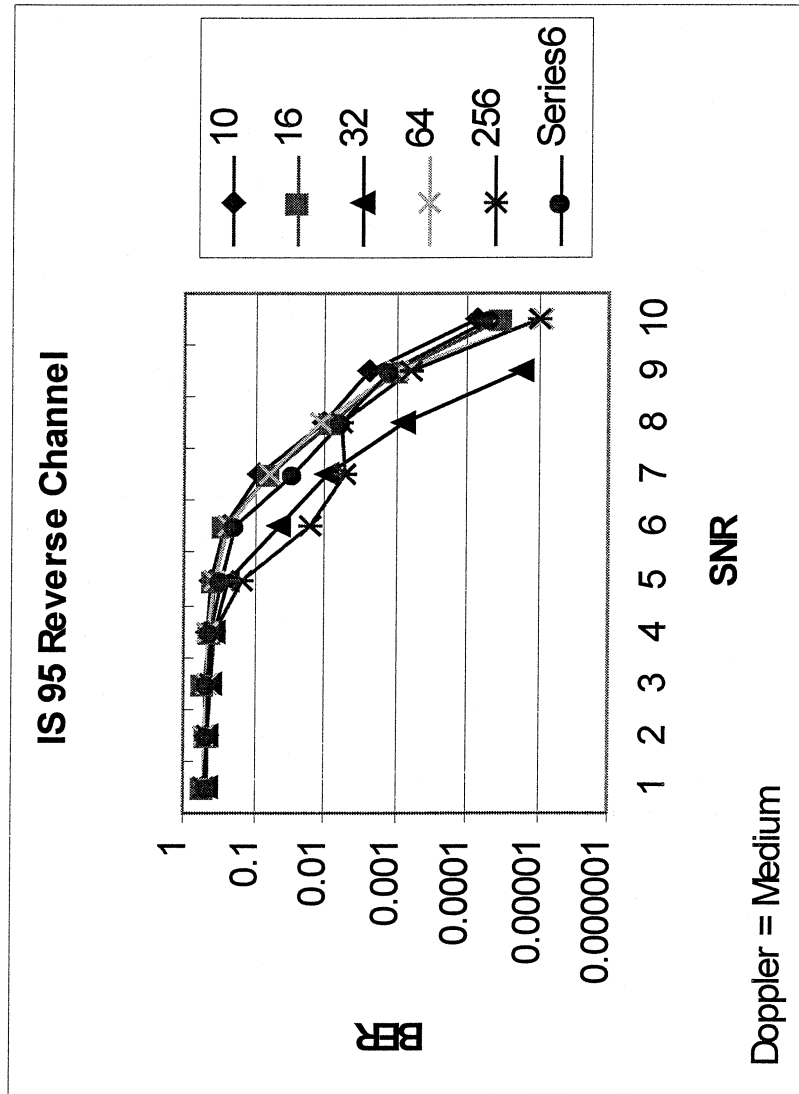

IS 95 Reverse Channel Doppler = Medium



EW RECEIVER AND PROCESSING CONCEPTS EVALUATION PROGRAM (RAPCEval)

Houston Jones
MSEE Program
Final

ERROR CORRECTION IN A MULTIPATH FADING ENVIRONMENT

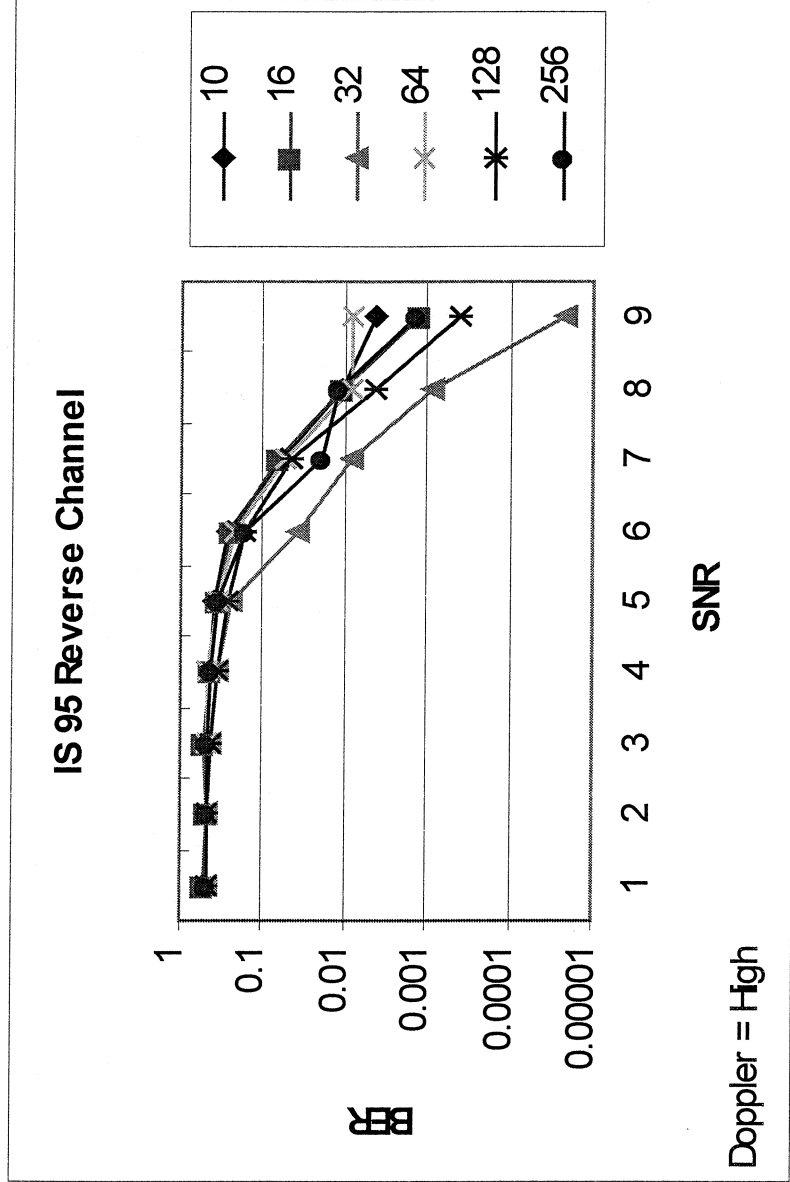

IS 95 Reverse Channel Doppler = High

5.1.6 Presentation by Mark Napier

The student briefing presented by Mark Napier at this meeting is reproduced on the next 33 pages.



EW RECEIVER AND PROCESSING CONCEPTS EVALUATION PROGRAM (RAPCEval)

Mark Napier
Presentation
5/3/2001

RESEARCH PRESENTATION

David M. Napier

Scientific Atlanta

ASIC Engineer, Digital Subscriber Group

Background and Experience:

Education: BSCPE from North Carolina State University.

Pursuing MSEE with emphasis in Digital

Communications - 32 Semester hours completed.

Scientific Atlanta:

Digital and Analog Electronics Design, ASIC design and test.

Research Topic:

*APPLICATION OF REED-SOLOMON ENCODING TO IMPROVE PROPOSED
COLLISION AVOIDANCE SYSTEM BASED ON CIVILIAN ATCRBS*



**EW RECEIVER AND PROCESSING
CONCEPTS EVALUATION PROGRAM
(RAPCEval)**

Mark Napier
Presentation
5/3/2001

OUTLINE

- ★ Quick System Overview
- ★ Channel Analysis and Results
- ★ Hardware Decoder
- ★ Work in Progress
- ★ Conclusions



EW RECEIVER AND PROCESSING CONCEPTS EVALUATION PROGRAM (RAPCEval)

Mark Napier
Presentation
5/3/2001

*APPLICATION OF REED-SOLOMON ENCODING TO IMPROVE PROPOSED
COLLISION AVOIDANCE SYSTEM BASED ON CIVILIAN ATCRBS*

Introduction

The civilian aircraft transponders are based on a WWII IFF (Information Friend or Foe) system. It is intended for ground-based ATCRBS (Air Traffic Control Radar Beacon System) use and in general no information is available to aircraft not using air traffic control services. TCAS provides major air carriers with collision avoidance information but is an expensive system that has very limited capacity. A distributed collision avoidance system using GPS (Global Positioning System) would be inexpensive and highly reliable.



EW RECEIVER AND PROCESSING CONCEPTS EVALUATION PROGRAM (RAPCEval)

Mark Napier
Presentation
5/3/2001

The current system interrogates aircraft on 1030 MHz. The transponders respond on 1090 MHz with mode 3A (squawk code), mode C (squawk altitude), or various mode S (squawk ID) messages depending on the interrogation sequence received and the transponder's capability. It transmits at a peak power output of 250 watts. It uses pulse shaping such that the transmitted power at plus or minus 25 MHz is down by 60 dB [TSO C74C]. The receiver circuit has a threshold sensitivity of -70 dBm.

A proposed scheme[1] would use current transponder technology to transmit at random intervals GPS position and velocity along with barometric altitude in addition to the normal mode 3 A/C responses. If widely used, any aircraft with a compatible receiver could have a cockpit display showing other aircraft in the area. The new system has been named "Tail Light," analogous to the tail light in a car at night or in the fog.

The proposed system would use the mode S downlink format signaling which is a PPM (Pulse Position Modulation) scheme with a 1 Mbit/s rate. A "1" is defined to be a 0.5 us burst followed by 0.5 us of off time. A "0" is defined to be 0.5 us of off time followed by a 0.5 us burst. The message is preceded by a 8 us sync pulse. Either 56 (single length) or 112 (double length) bits of data follow.



EW RECEIVER AND PROCESSING CONCEPTS EVALUATION PROGRAM (RAPCEval)

Mark Napier
Presentation
5/3/2001

For the double length message, 40 bits have been assigned for Forward Error Correction (FEC) using Reed-Solomon encoding. Since this is a short message, the optimal burst error capability is obtained[2] with a 5-bit $t=4$ or RS(31,23) code. This code can correct a 16-bit worst case burst error.

8

Also, if erasure information can be provided by the receiver a burst error of 36 bits can be corrected effectively doubling the error correction capability[3]. Note that with PPM a simple system for obtaining erasure information is available. Since "00" and "11" are not defined, any bit received with these sequences should be flagged as an erasure. As these bits are arranged into 5-bit words for the decoder, the word would be marked as an erasure.

The proposed system would be a benefit for general aviation which lacks a cost effective solution for collision avoidance. The FEC scheme proposed would greatly enhance overall system reliability. Lastly, the RS(31,23) decoder would be useful for any mobile system that uses short (61-155 bits) bursts of data.



EW RECEIVER AND PROCESSING CONCEPTS EVALUATION PROGRAM (RAPCEval)

Mark Napier
 Presentation
 5/3/2001

Tail Light Short Format Message, 56 bits.

Field	Length	Description
Preface	5 bits	TBD, possible DF27 or 11010 base 2.
Latitude	12 bits	Minutes and tenths (MM.M). Precision is 0.1 minutes = 600 feet. Period is 59.9' = 60 NM. The first byte, tens of minutes, only ranges from 0 through 5, thus doesn't use the MSB. Set that bit to 0 for north, and 1 for south. 3 numbers, 12 bits.
Longitude	12 bits	Similar to latitude. Set the MSB of the tens of minutes byte to 0 for west and 1 for east. From 70 through 80 degrees latitude send ones of degrees through whole minutes (DMM). Above 80 degrees send whole degrees only (DDD) and put the E/W bit in the otherwise unused first bit of the hundreds of degrees. 3 numbers, 12 bits.
Altitude	10 bits	From Altitude Encoder.
Speed	8 bits	10 knots precision, up to 990 knots. 2 numbers, 8 bits.
Course	8 bits	10 degrees precision, 000-350 degrees true. Use the otherwise unused MSB of the hundreds of degrees to include the validity flag. 2 numbers, 8 bits.
Parity	1 bit	Single parity bit for message.



EW RECEIVER AND PROCESSING CONCEPTS EVALUATION PROGRAM (RAPCEval)

Mark Napier
Presentation
5/3/2001

Tail Light Long Format Message, 112 bits.

Field	Length	Description
Preface	5 bits	TBD, possible DF26 or 11010 base 2.
Latitude	16 bits	Ones of degrees, minutes and tenths (DMM.M). Precision is 0.1 minutes = 600 feet. Period is 9 degrees, 59.9 minutes = 600 NM. The second byte, tens of minutes, only ranges from 0 through 5, thus doesn't use the MSB. Set that bit to 0 for north, and 1 for south. 4 numbers, 16 bits.
Longitude	16 bits	Similar to latitude. Set the MSB of the tens of minutes byte to 0 for west and 1 for east. From 70 through 80 degrees latitude send tens of degrees through whole minutes (DDMM). Above 80 degrees send whole degrees and tens of minutes (DDDM). 4 numbers, 16 bits.
Altitude	10 bits	From Altitude Encoder.
Speed	12 bits	000-999 knots. If the craft is traveling over 999 knots, send 999, don't blindly drop the leading byte and send 000. 3 numbers, 12 bits.
Course	12 bits	000-359 degrees true. Use the otherwise unused MSB of the hundreds of degrees to include the message validity flag. 3 numbers, 12 bits.
Stuff Bit	1 bit	TBD
FEC Parity	40 bits	RS(31,23) code. 5 bit symbols, t = 4.



EW RECEIVER AND PROCESSING CONCEPTS EVALUATION PROGRAM (RAPCEval)

Mark Napier
Presentation
5/3/2001

Channel Analysis and Results

Mode S airborne transmissions use Pulse Position Modulation (PPM). In PPM each bit interval T is broken up into two slots. A "10" in an interval represents a logic "1" and a "01" represents a logic "0". The reception of the pulse at each of these slot locations can be treated individually. Since the receiver uses envelope detection this is essentially On Off Keying (OOK). For each of these pulses there exists a probability ρ that pulse will be received in error. For OOK the pulse error rate can be approximated by the following equation:

$$\rho = \frac{1}{2} \exp\left(-\frac{1}{2} \frac{E_b}{N_0}\right),$$

where E_b is the energy per bit and N_0 is the noise spectral density at the receiver[6]. Note this is also the equation for noncoherent FSK. However, since OOK only transmits half of the time, it requires twice the peak power level for the same error performance as FSK.

If the error probability ρ is assumed to operate on a binary symmetric channel, then $(1 - \rho)$ is the probability of no error.



EW RECEIVER AND PROCESSING CONCEPTS EVALUATION PROGRAM (RAPCEval)

Mark Napier
Presentation
5/3/2001

Binary Symmetric Channel

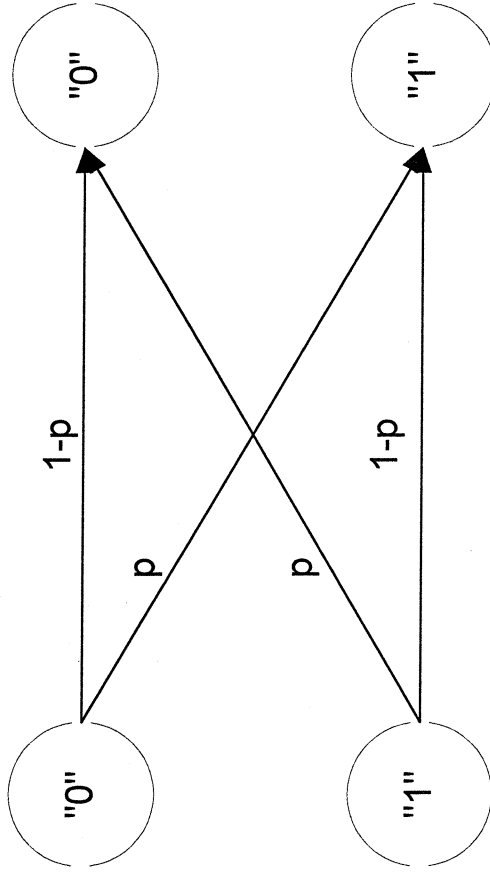

“p” is the probability of making an error.



EW RECEIVER AND PROCESSING CONCEPTS EVALUATION PROGRAM (R A P C E v a l)

Mark Napier
Presentation
5/3/2001

For PPM the two starting conditions are “10” or “01”. If the same assumption for binary symmetry is made for both bit positions, then applying Bayes’ theorem leads to three possibilities:

$p_{ce} = \rho^2$ p_{ce} is the probability of bit error where
both pulses are incorrect.

$p_{cs} = 2\rho(1-\rho)$ p_{cs} is the probability of bit erasure where
one pulse is incorrect.

$p_{cc} = (1-\rho)^2$ p_{cc} is the probability of a correct bit
where both pulses are correct.



EW RECEIVER AND PROCESSING CONCEPTS EVALUATION PROGRAM (RAPCEval)

Mark Napier
Presentation
5/3/2001

Probability of error and erasure.

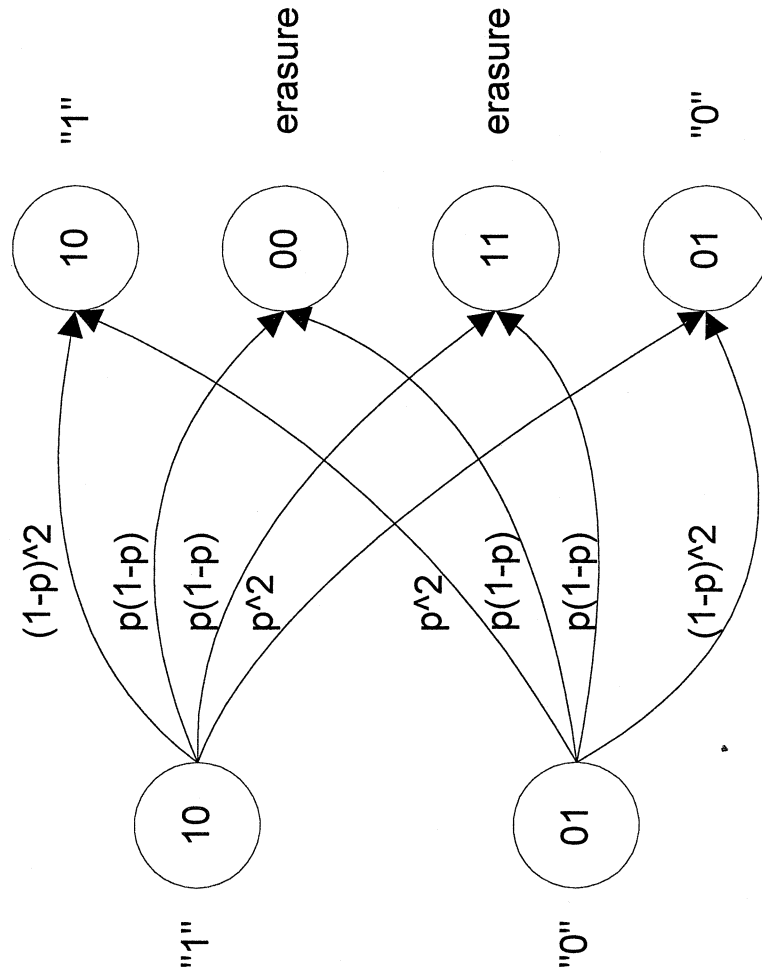



EW RECEIVER AND PROCESSING CONCEPTS EVALUATION PROGRAM (RAPCEval)

Mark Napier
Presentation
5/3/2001

Probability of bit errors and erasures.

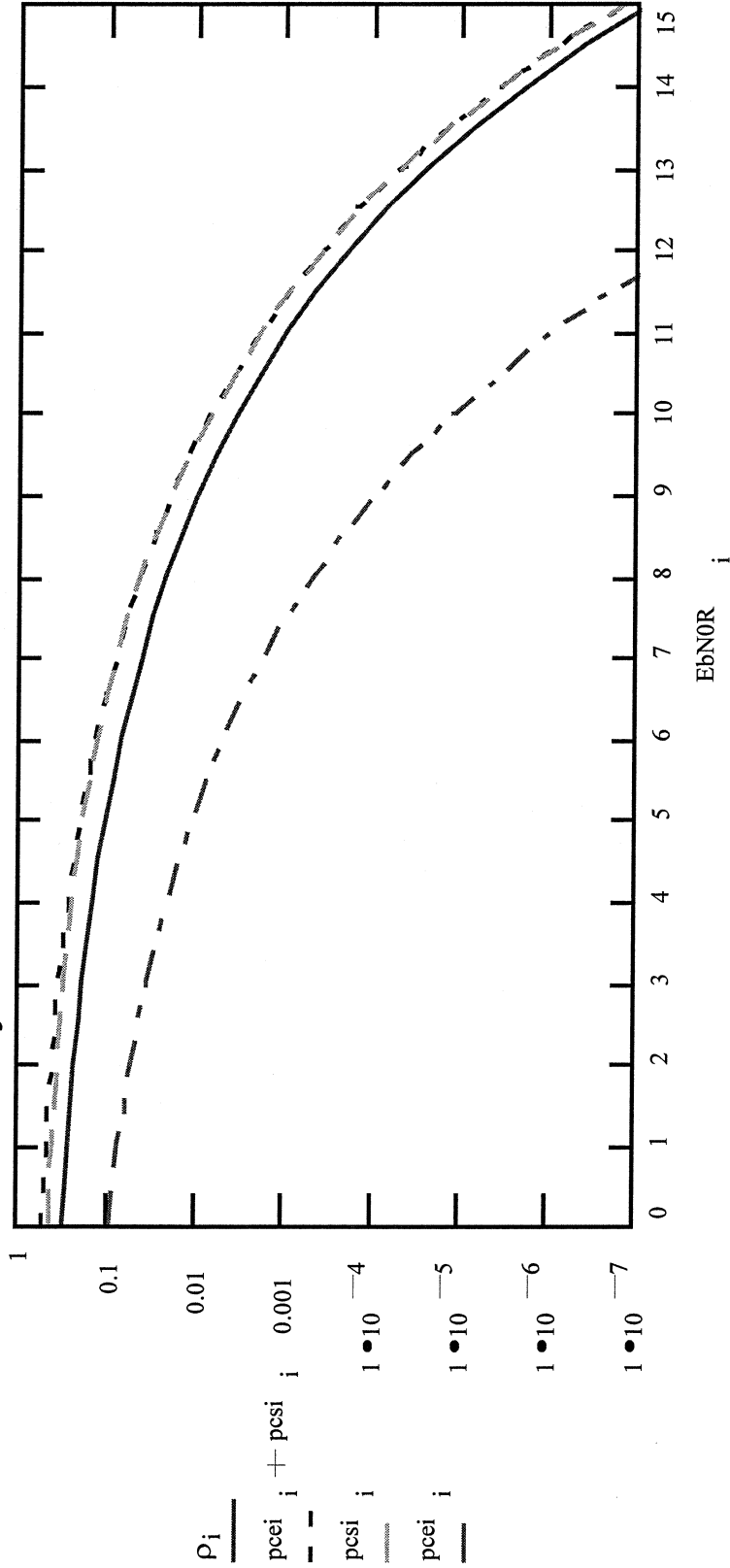

Half bit error rate (ρ), channel bit error rate (pce), and channel bit erasure rate (pcs) versus dB E_b/N_0 .



EW RECEIVER AND PROCESSING CONCEPTS EVALUATION PROGRAM (RAPCEval)

Mark Napier
 Presentation
 5/3/2001

Taillight uses a parity bit to help detect errors in the 56 bit short packet. The parity bit will catch all odd numbers of bit errors not detected as bit erasures. Therefore the probability of receiving an undetected error P_{ue} is the sum of all combinations of even numbers of error bits with the rest of the packet containing correct bits. If n equals the number bits in a short packet this can be expressed as:

$$P_{ue} = \sum_{i=1}^{n/2} \binom{n}{2i} p c e^{2i} p c c^{(n-2i)}, \quad \text{where } P_{ue} \text{ is the probability of an undetected bit error.}$$

P_{ue} can be expressed directly in term of ρ as:

$$P_{ue} = \sum_{i=1}^{n/2} \binom{n}{2i} \rho^{4i} (1-\rho)^{2(n-2i)},$$

where $\binom{n}{m} = \frac{n!}{m!(n-m)!}$ is the number of combinations of n things taken m at a time.

$$P_{de} = p c c^n = (1-\rho)^{2n}, \quad \text{where } P_{de} \text{ is the probability of a detected error.}$$



EW RECEIVER AND PROCESSING CONCEPTS EVALUATION PROGRAM (RAPCEval)

Mark Napier
Presentation
5/3/2001

Short Format (56 bit) Packet Error Performance

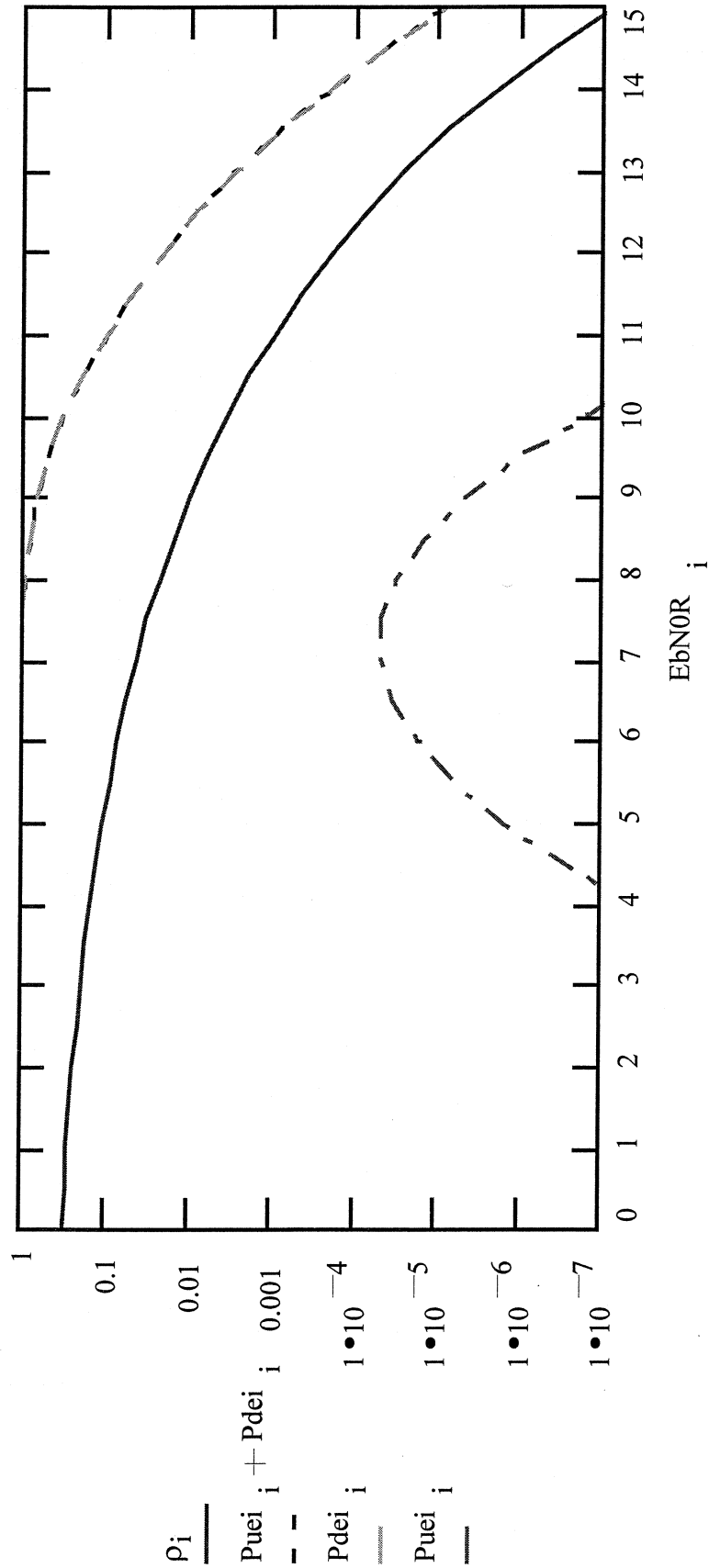

Half bit error rate (ρ), detected packet error rate (P_{de}), and undetected packet error rate (P_{ue}) versus dB E_b/N_0 .



EW RECEIVER AND PROCESSING CONCEPTS EVALUATION PROGRAM (RAPCEval)

Mark Napier
Presentation
5/3/2001

The 112-bit format message is protected by a RS(23,15) code word. This code word contains eight 5-bit parity symbols. Given that $m = 5$ bits, the symbol error and erasure probabilities are given[7] by:

$$p_s = 1 - (1 - pcs)^m,$$

where p_s is the probability of a symbol error and

$$p_e = (1 - pcs)^m - (1 - pce - pcs)^m,$$

where p_e is the probability of a symbol erasure.



EW RECEIVER AND PROCESSING CONCEPTS EVALUATION PROGRAM (RAPCEval)

Mark Napier
Presentation
5/3/2001

5-Bit Symbol Error Performance

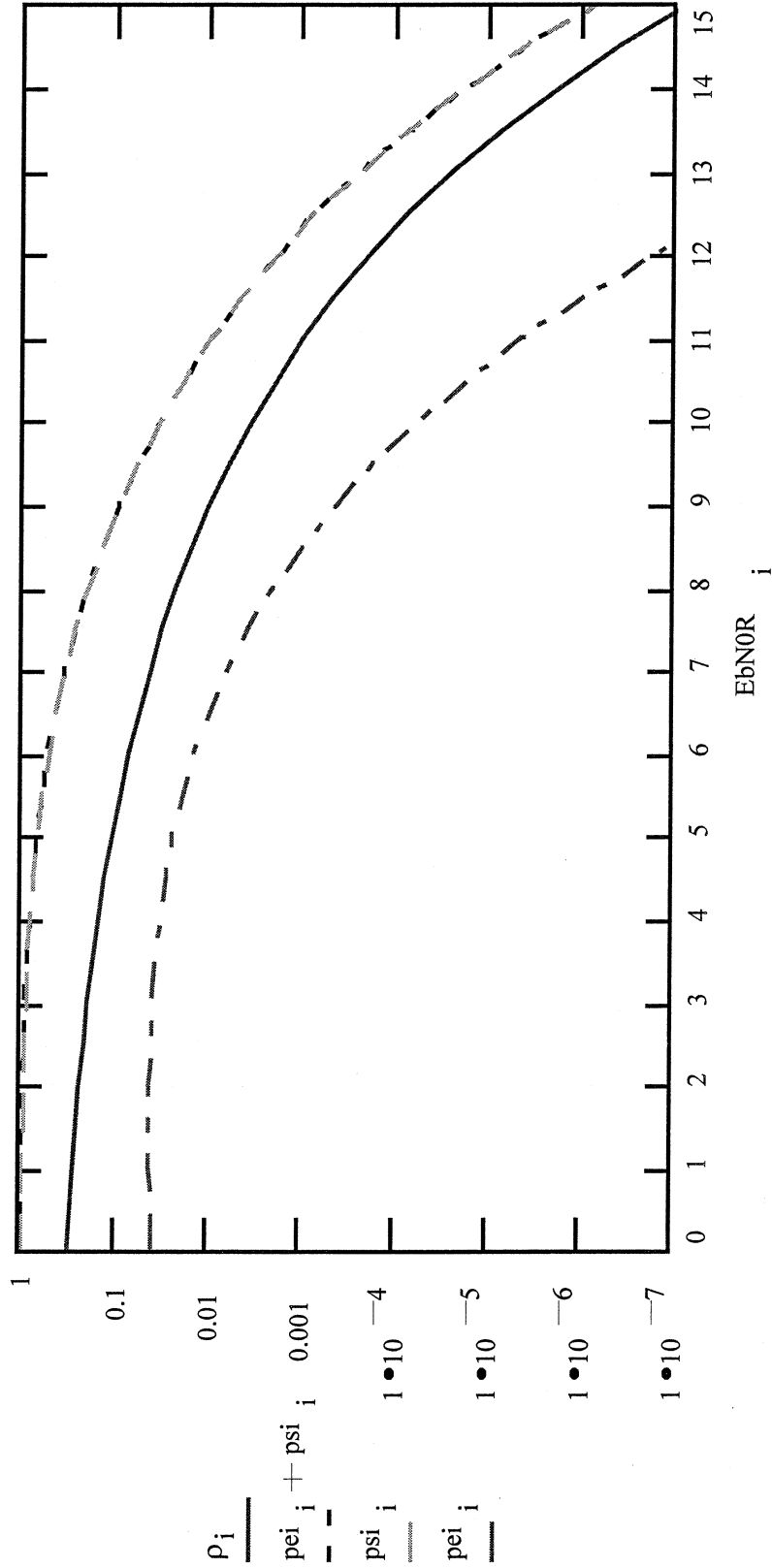

Half bit error rate (ρ), symbol error rate (pe), and symbol erasure rate (ps) versus dB E_b/N_0 .



EW RECEIVER AND PROCESSING CONCEPTS EVALUATION PROGRAM (RAPCEval)

Mark Napier
 Presentation
 5/3/2001

Equations[7] that predict the performance for an errors only RS(23,15) code:

$$P_c = \sum_{j=0}^{d_{\min}-1} \binom{n}{j} [(pe + ps)^j [1 - (pe + ps)]^{n-j}] \quad \text{Probability of receiving a correctable packet.}$$

$$A_j = \binom{n}{j} (2^m - 1)^j \sum_{i=0}^{j-d_{\min}} (-1)^i \binom{j-1}{i} 2^{m(j-i-d_{\min})} \quad \text{Number of weighted } j \text{ code words.}$$

$$P_k^j = \sum_{r=0}^k \binom{j}{k-r} \binom{n-j}{r} \left[\frac{pe+ps}{2^m-1} \right]^{j-k+r} \left[1 - \left(\frac{pe+ps}{2^m-1} \right) \right]^{k-r} [1 - (pe + ps)]^{n-j-r} (pe + ps)^r$$

Probability received
code word is distance
k from a weighted j
code word.

$$P_e = \sum_{j=d_{\min}}^n A_j \sum_{k=0}^{d_{\min}-1} P_k^j \quad \text{Probability of decoder error.}$$

$$P_f = 1 - P_c - P_e \quad \text{Probability of decoder failure or detecting an uncorrectable code word.}$$



EW RECEIVER AND PROCESSING CONCEPTS EVALUATION PROGRAM (RAPCEval)

Mark Napier
 Presentation
 5/3/2001

Long Format (112 bits) Errors Only RS Packet Error Performance

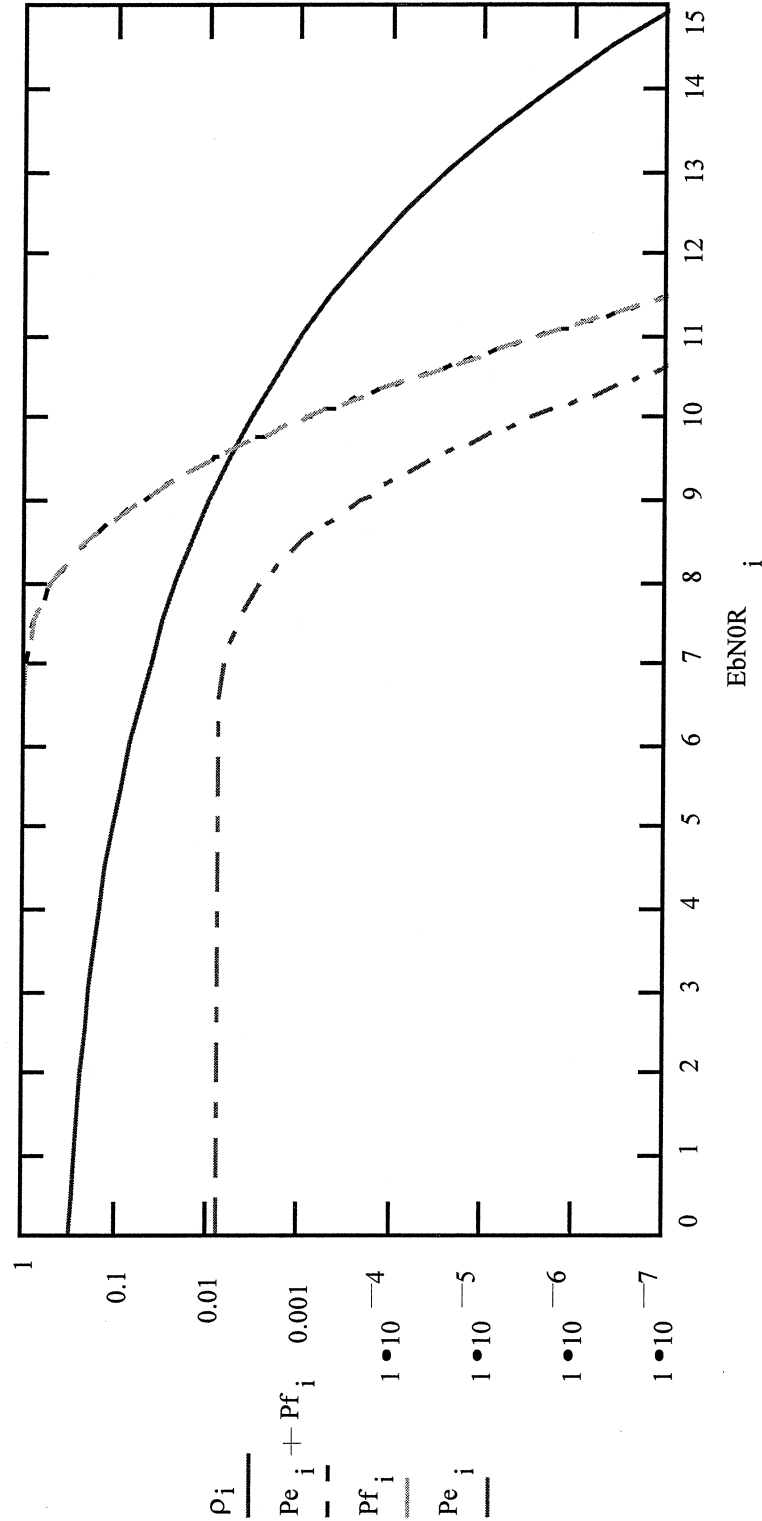

Half bit error rate (ρ), undetected packet error rate (P_e), and detected packet error rate (decoder failure P_f) versus dB E_b/N_0 .



EW RECEIVER AND PROCESSING CONCEPTS EVALUATION PROGRAM (RAPCEval)

Mark Napier
 Presentation
 5/3/2001

Equations[7] that Predict the Performance for an Errors and Erasures RS(23,15) Code

$$P_c = \sum_{v=0}^{d_{\min}-1} \sum_{w=0}^{d_{\min}-2v-1} \binom{n}{v} \binom{n-v}{w} [(1-ps-pe)^{v-v-w} ps^w pe^v]$$

Probability of receiving a correctable packet.

$$A_j = \binom{n}{j} (2^m - 1) \sum_{i=0}^{j-d_{\min}} (-1)^i \binom{j-1}{i} 2^{m(j-i-d_{\min})}$$

Number of weighted j code words.

$$Q_{d_{\min}}^j = \sum_{v=0}^{\lfloor \frac{d_{\min}-1}{2} \rfloor} \sum_{w=0}^{d_{\min}-2v-1} \sum_{x=0}^{\lfloor \frac{d_{\min}-2v-w-1}{2} \rfloor} d_{\min-2v-w-2x-1} \sum_{y=0}^{d_{\min-2v-w-2x-1} - \lfloor \frac{d_{\min}-2v-w-2x-y-1}{2} \rfloor}$$

Probability that the received code word falls into a decoding sphere surrounding a weighted j code word.

$$\binom{n-j}{v} \binom{n-j-v}{w} \binom{j}{x} \binom{j-x}{y} \binom{j-x-y}{z} \left[(2^m - 1)^v (2^m - 2)^y \left(\frac{pe}{2^m - 1} \right)^{j+v-y-z} ps^{w+y} (1-ps-pe)^{n-j-v-w+z} \right]$$

$$P_e = \sum_{j=d_{\min}}^n A_j Q_{d_{\min}}^j \quad \text{Probability of decoder error.}$$

$$P_f = 1 - P_c - P_e \quad \text{Probability of decoder failure or detecting an uncorrectable code word.}$$



EW RECEIVER AND PROCESSING CONCEPTS EVALUATION PROGRAM (RAPCEval)

Mark Napier
 Presentation
 5/3/2001

Long Format (112 bits) Errors and Erasures RS Packet Error Performance

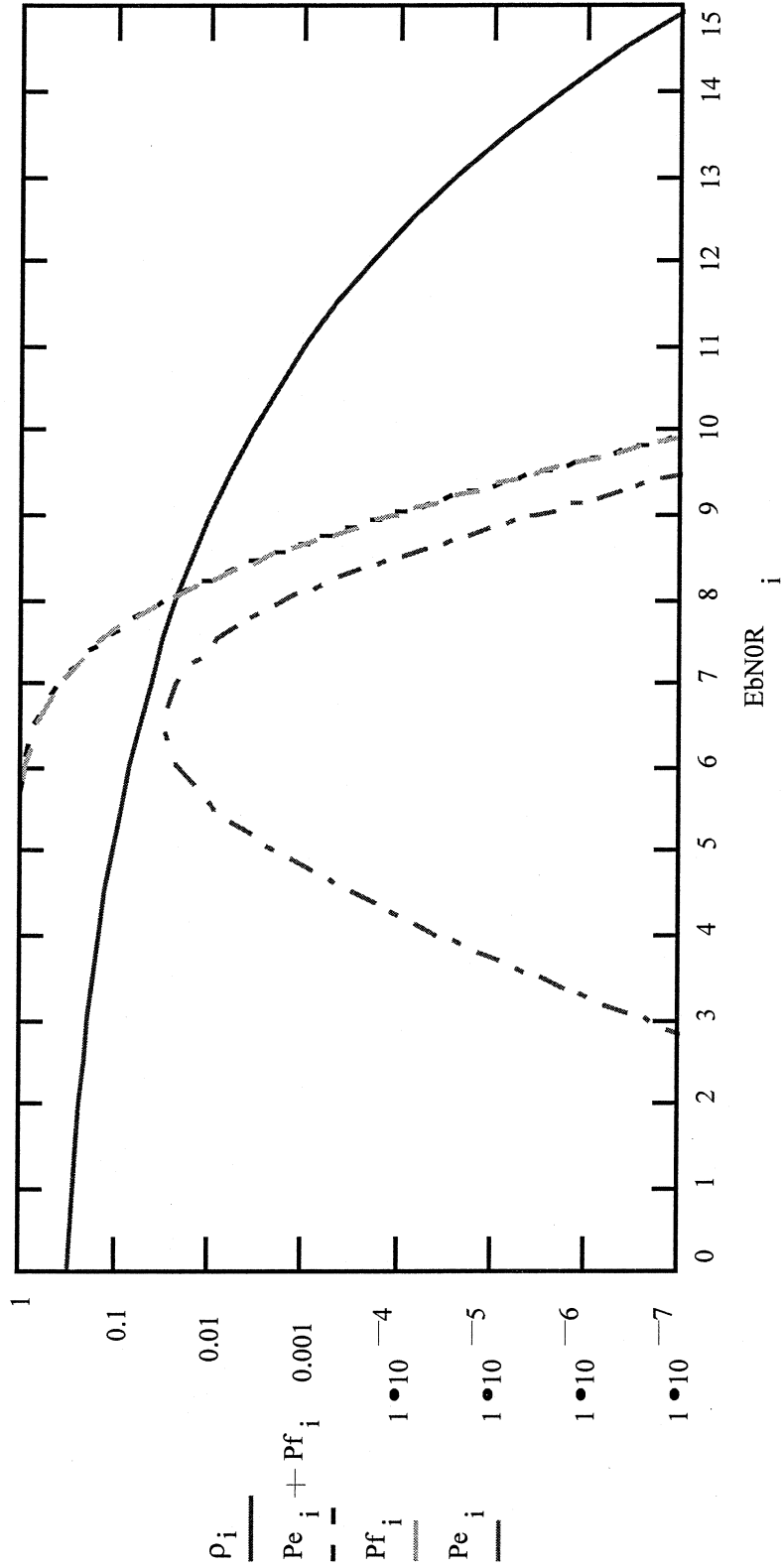

Half bit error rate (ρ), undetected packet error rate (P_e), and detected packet error rate (decoder failure P_f) versus dB E_b/N_0 .



EW RECEIVER AND PROCESSING CONCEPTS EVALUATION PROGRAM (RAPCEval)

Mark Napier
Presentation
5/3/2001

MTL Performance Gain

A Reed-Solomon code is primarily used for burst error correction. However, in this case because of the inherent redundancy of the PPM signaling, a significant coding gain is realized. A transponder normally has a minimum triggering level (MTL) set so that it will respond at some power level where 90% of the packets can be received without error. This power level is reduced with coding.

- * The 56-bit MTL $E_b/N_0 = 10.99$ dB.
- * The 112-bit errors only RS MTL $E_b/N_0 = 8.77$ dB.
- * The 112-bit errors and erasures RS MTL $E_b/N_0 = 7.61$ dB.



EW RECEIVER AND PROCESSING CONCEPTS EVALUATION PROGRAM (RAPCEval)

Mark Napier
Presentation
5/3/2001

Simulation to Verify RS(23,15) Performance

An errors and erasures decoder based on an algorithm presented by Jeng[3] has been prototyped in C. The C prototype has been tested and verified with over 100 million random vectors with random combinations of errors and erasures. As implemented it is a RS(31,23) code that has been shortened by assuming that the first eight symbols are zeros.

The C prototype has also served as a test bench to simulate and verify the calculated performance. The half bit error probability is used to generate random error vectors. These vectors are then used to generate symbol errors and erasures with the same statistics as the channel would generate at a given power level. The results correlate exactly with the predicted results.



EW RECEIVER AND PROCESSING CONCEPTS EVALUATION PROGRAM (RAPCEval)

Mark Napier
Presentation
5/3/2001

Simulation Results

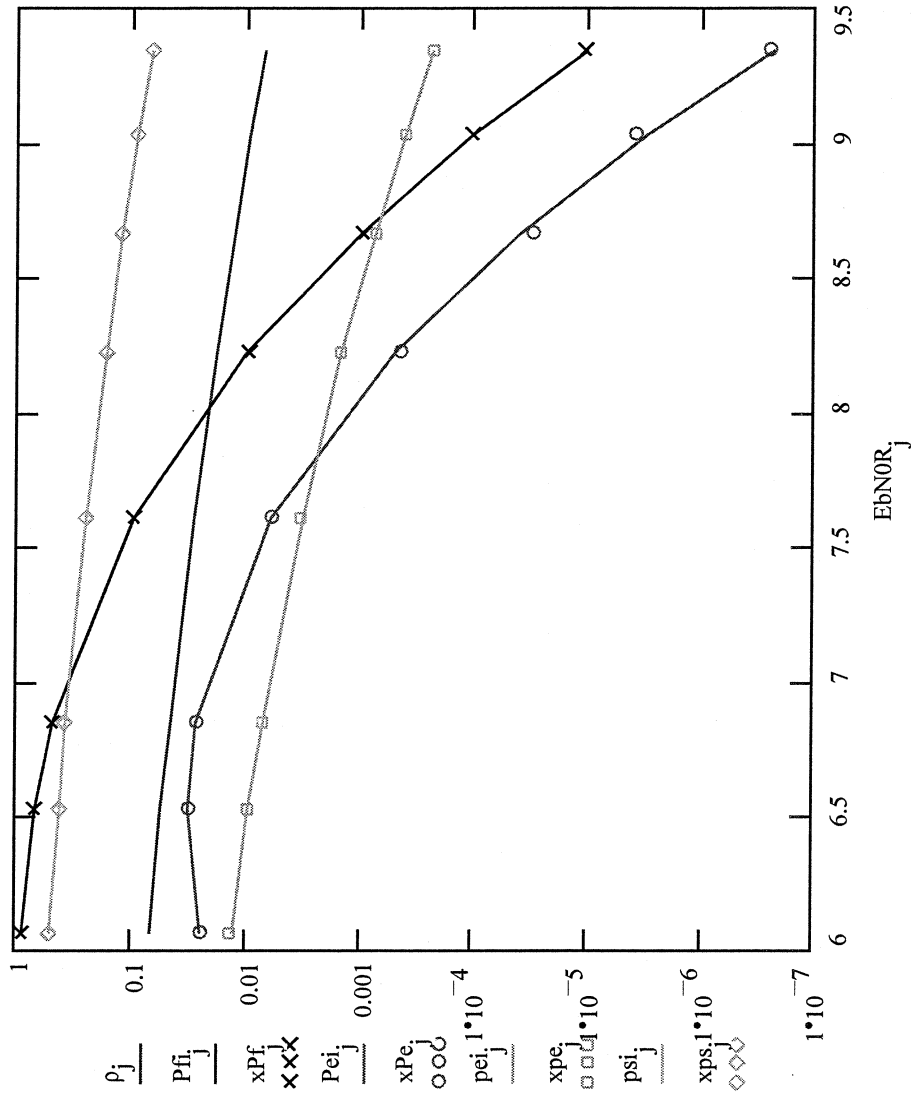

Half bit error rate (ρ), Calculated and simulated decoder failure rate (P_{fi} and xP_{fj}), decoder error rate (P_{ei} and xP_{ej}), symbol error rate (pej and xpe_j), and symbol erasure rate (psi and xps) versus E_b/N_0 .



EW RECEIVER AND PROCESSING CONCEPTS EVALUATION PROGRAM (RAPCEval)

Mark Napier
Presentation
5/3/2001

Verilog RS(23,15) Hardware Decoder

The Reed-Solomon (23,15) errors and erasures decoder has been implemented in Verilog. It is based on an algorithm presented by Jeng[3] as a RS(31,23) code that has been shortened by assuming that the first eight symbols are zeros.

It has been verified in a Verilog simulation with over 10 million random vectors.

This code can be readily synthesized to gates and implemented in either an ASIC or an FPGA. The hardware required is relatively modest and it will fit into an inexpensive FPGA. Also the architecture is easily scalable for any other RS code.



**EW RECEIVER AND PROCESSING
CONCEPTS EVALUATION PROGRAM
(RAPCEval)**

Mark Napier
Presentation
5/3/2001

Reed-Soloman (31,23) Encoder (Shortened)

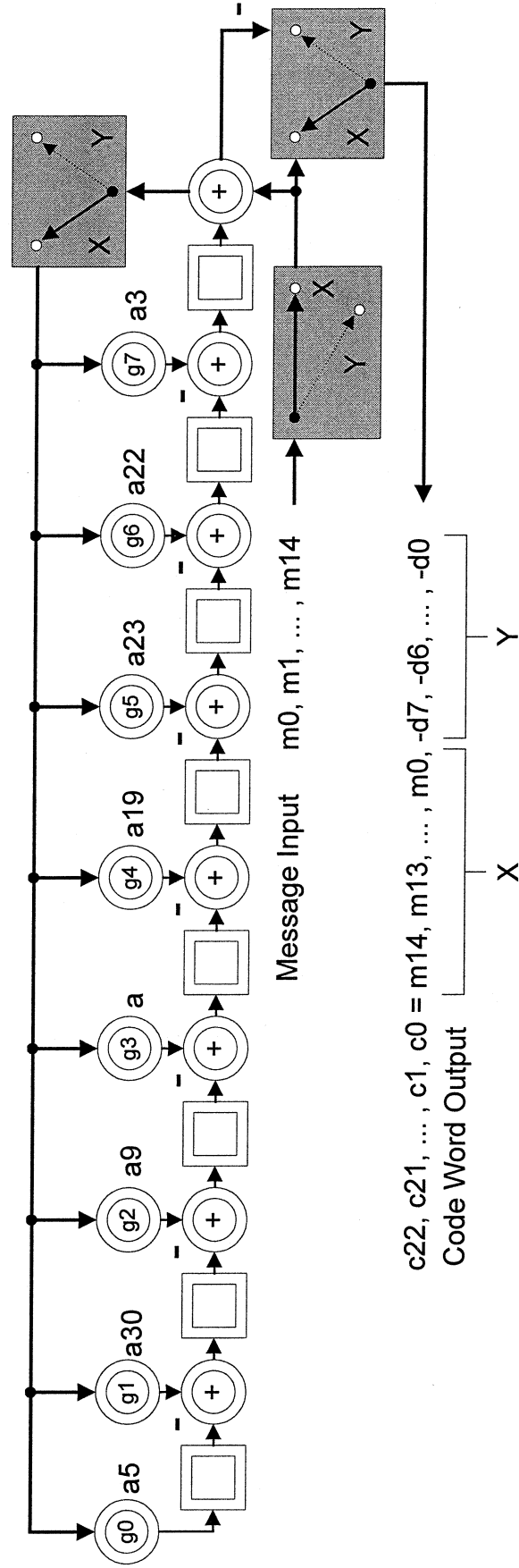



EW RECEIVER AND PROCESSING CONCEPTS EVALUATION PROGRAM (RAPCEval)

Mark Napier
Presentation
5/3/2001

Reed-Solomon (23,15) Decoder

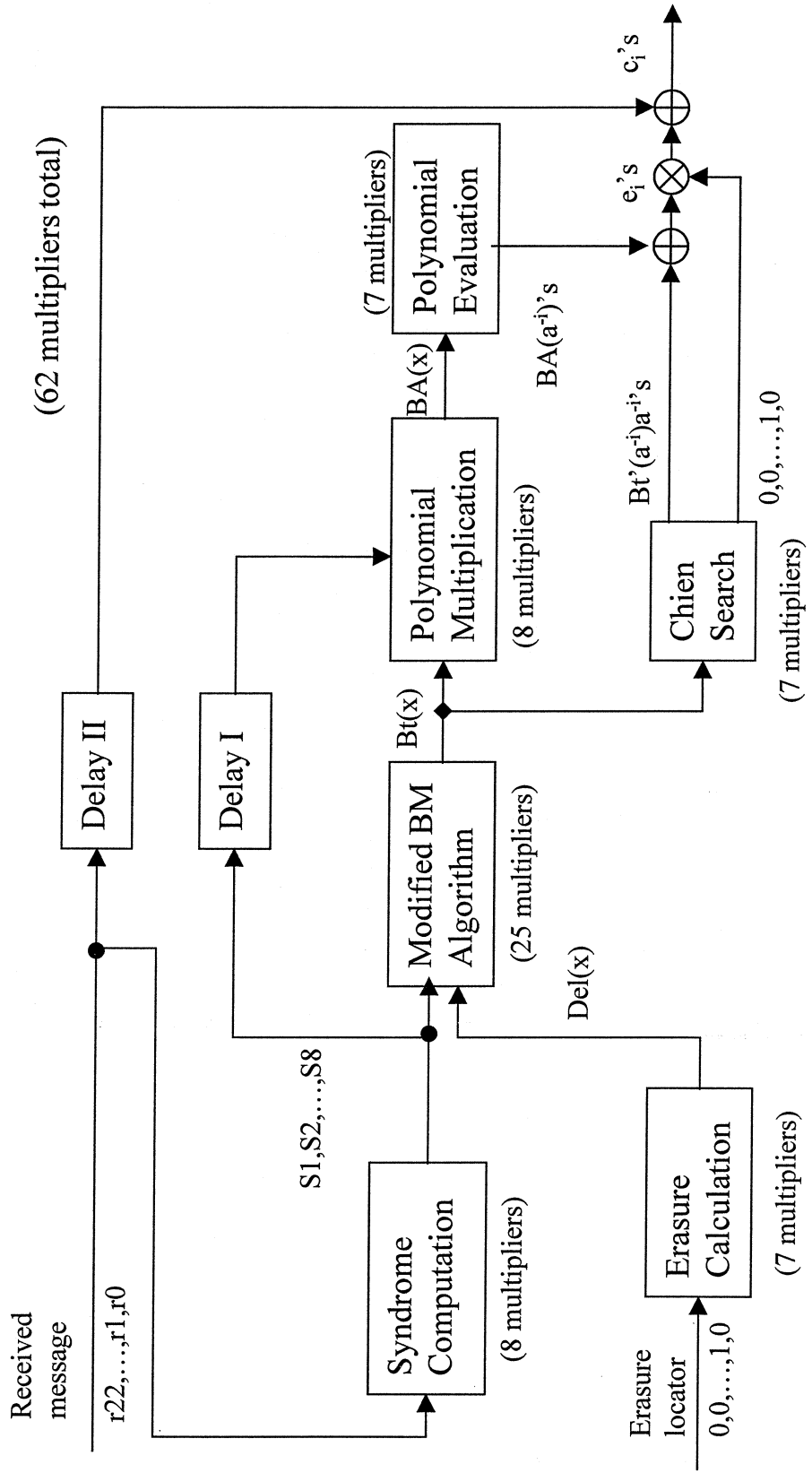



EW RECEIVER AND PROCESSING CONCEPTS EVALUATION PROGRAM (RAPCEval)

Mark Napier
Presentation
5/3/2001

APPLICATION OF REED-SOLOMON ENCODING TO IMPROVE PROPOSED COLLISION AVOIDANCE SYSTEM BASED ON CIVILIAN ATCRBS

Work In Progress

Based on information provided by Lincoln Laboratory[4][5] and a phone conversation with Dr. Orlando, the emphasis of the simulation will be altered somewhat. Since the Mode S channel is operated at a high SNR and under line-of-sight conditions, channel fading is not a normal concern, and the BER is very low. However there is another more common source of burst errors. Mode 3A/C replies from other aircraft that interfere are named FRUIT (False Replies Unsynchronized in Time). These burst errors will be simulated using the C test bench.

As a prediction take note that each 5-bit RS symbol occupies 5 us. Also note that the Mode 3A/C reply can last at most 25.1 us and can only effect six 5-bit symbols worst case. The RS(23,15) code will be very effective at correcting these burst errors.



EW RECEIVER AND PROCESSING CONCEPTS EVALUATION PROGRAM (RAPCEval)

Mark Napier
 Presentation
 5/3/2001

Mode 3/A and Mode C Reply Waveform[8]

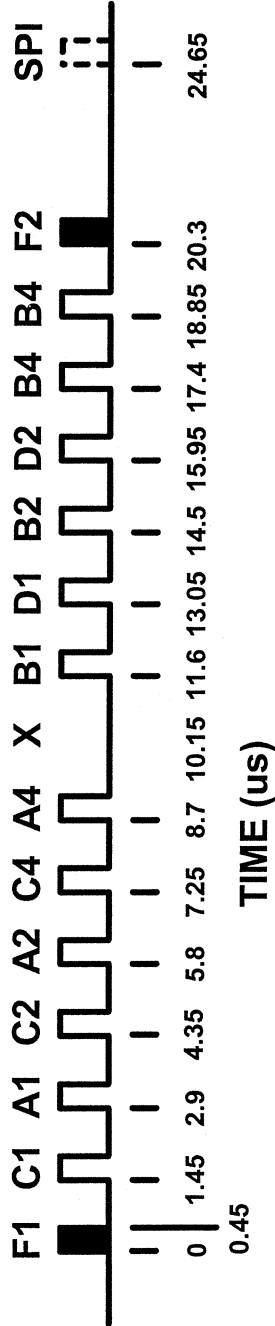

Overlapping FRUIT - False Replies Unsynchronized In Time.



EW RECEIVER AND PROCESSING CONCEPTS EVALUATION PROGRAM (RAPCEval)

Mark Napier
Presentation
5/3/2001

Mode A Packet - Four -
digit squawk code from
front panel is encoded in
octal form.

Mode C Packet -
Identical to Mode A
packet. Altitude encoded
on 10 bits of the digit
values.

Bit	Description
F1	1 st Framing Bit - 1
C1	3 rd Digit 1's Value
A1	1 st Digit 1's Value
C2	3 rd Digit 2's Value
A2	1 st Digit 2's Value
C4	3 rd Digit 4's Value
A4	1 st Digit 4's Value
X	No Transmit - 0
B1	2 nd Digit 1's Value
D1	4 th Digit 1's Value
B2	2 nd Digit 2's Value
D2	4 th Digit 2's Value
B4	2 nd Digit 4's Value
D4	4 th Digit 4's Value
F2	2 nd Framing Bit - 1
X	No Transmit - 0
X	No Transmit - 0
SPIP	Special Purpose ID Pulse; Front Panel Ident. Button.



**EW RECEIVER AND PROCESSING
CONCEPTS EVALUATION PROGRAM
(RAPCEval)**

Mark Napier
Presentation
5/3/2001

Conclusions

- ★ The RS code gives significant reliability improvements.
- ★ It should also correct for most overlapping FRUIT.
- ★ The RS(23,15) engine will fit into inexpensive hardware.
- ★ This particular implementation is readily adaptable for other RS codes.



EW RECEIVER AND PROCESSING CONCEPTS EVALUATION PROGRAM (RAPCEval)

Mark Napier
Presentation
5/3/2001

References:

- [1] Peshak, B. Keith; <http://www.gtwn.net/~keith.peshak/taillight.htm>
- [2] B. Kamali, "Some new Outlooks on Burst Error Correction Capabilities of Reed-Solomon Codes with Applications in Mobile-Communications," Proceedings of IEEE VTC'98, Ottawa, Canada, May 1998, pp. 343-347
- [3] J. H. Jeng and T. K. Truong, "On Decoding of Both Errors and Erasures of a Reed-Solomon Code Using an Inverse-Free Berlekamp-Massey Algorithm," IEEE Transactions on Communications, VOL. 47, NO. 10, Oct. 1999, pp. 1488-1494
- [4] V. A. Orlando, "Mode S Beacon System: A Functional Overview," Project Report ATC-150, Rep. NO. DOT/FAA/PM-89/7, Lincoln Lab. M.I.T., 29 August 1989
- [5] V. A. Orlando and P. R. Drouilhet, "Mode S Beacon System: Functional Description," Project Report ATC-42 Rev. D, Rep. NO. DOT/FAA/PM-86/19, Lincoln Lab. M.I.T., Aug. 1986



EW RECEIVER AND PROCESSING CONCEPTS EVALUATION PROGRAM (RAPCEval)

Mark Napier
Presentation
5/3/2001

References Continued:

- [6] B. Sklar, *Digital Communications Fundamentals and Applications*, Prentice-Hall Inc., New Jersey, 1988.
- [7] Stephen B. Wicker, *Error Control Systems for Digital Communication and Storage*, Prentice-Hall Inc., New Jersey, 1988.
- [8] TSO-C74c, *Airborne ATC Transponder Equipment*, F.A.A Aircraft Certification Service, Washington, DC, 1973

5.1.7 Presentation by Zoran Sevarlic

The student briefing presented by Zoran Sevarlic at this meeting is reproduced on the next 45 pages.



RECEIVER AND PROCESSING
CONCEPTS EVALUATION PROGRAM
(RAPCEval)

Zoran Sevarlic
INTERIM
2001 MAY

CORRECTION OF PHASE ERRORS WITH AUTOFOCUS
RESEARCH THESIS INTERIM PRESENTATION

May 3, 2001

Zoran Sevarlic

USAF/WR-ALC, LYSFR

Background and Experience:

Education: BSEE from University of Memphis
Pursuing MSEE - 30 hours completed
Current Job: F-15 Software Engineer

Research Topic:

*USE OF AUTOFOCUS TECHNIQUES IN THE CORRECTION
OF PHASE ERRORS IN RADAR SIGNALS*



**RECEIVER AND PROCESSING
CONCEPTS EVALUATION PROGRAM
(RAPCEval)**

Zoran Sevarlic
INTERIM
2001 MAY

CORRECTION OF PHASE ERRORS WITH AUTOFOCUS

INTRODUCTION

- ★ Problem statement
- ★ Modeling and measuring phase error
- ★ Compare model with real data
- ★ Various Autofocus techniques
- ★ Conclusions
- ★ Further research



RECEIVER AND PROCESSING
CONCEPTS EVALUATION PROGRAM
(RAPCEval)

Zoran Sevarlic
INTERIM
2001 MAY

CORRECTION OF PHASE ERRORS WITH AUTOFOCUS

PROBLEM STATEMENT

- ★ Smearing Doppler lines create problems identifying signals
- ★ Ownship or target maneuvers contribute to smeared Doppler filters



RECEIVER AND PROCESSING
CONCEPTS EVALUATION PROGRAM
(RAPCEval)

Zoran Sevaric
INTERIM
2001 MAY

CORRECTION OF PHASE ERRORS WITH AUTOFOCUS

INTRODUCTION

- ★ Defocus comes from the assumption that phase of target return is linear (i.e., constant Doppler)
- ★ In the frequency domain, phase errors:
 - Smear signal energy across more filters
 - Reduce signal amplitude
- ★ Autofocus is a signal-based motion-compensation technique that reduces phase nonlinearity



RECEIVER AND PROCESSING
CONCEPTS EVALUATION PROGRAM
(RAPCEval)

Zoran Sevarlic
INTERIM
2001 MAY

CORRECTION OF PHASE ERRORS WITH AUTOFOCUS

MODELING PHASE DISTORTION

$$s(t) = e^{j2\pi(ft + d_2t^2 + d_3t^3 + n(t))}$$

d_2 2nd order phase delay

d_3 3rd order phase delay

$n(t)$ Gaussian noise



RECEIVER AND PROCESSING CONCEPTS EVALUATION PROGRAM (RAPCEval)

Zoran Sevarlic
INTERIM
2001 MAY

CORRECTION OF PHASE ERRORS WITH AUTOFOCUS

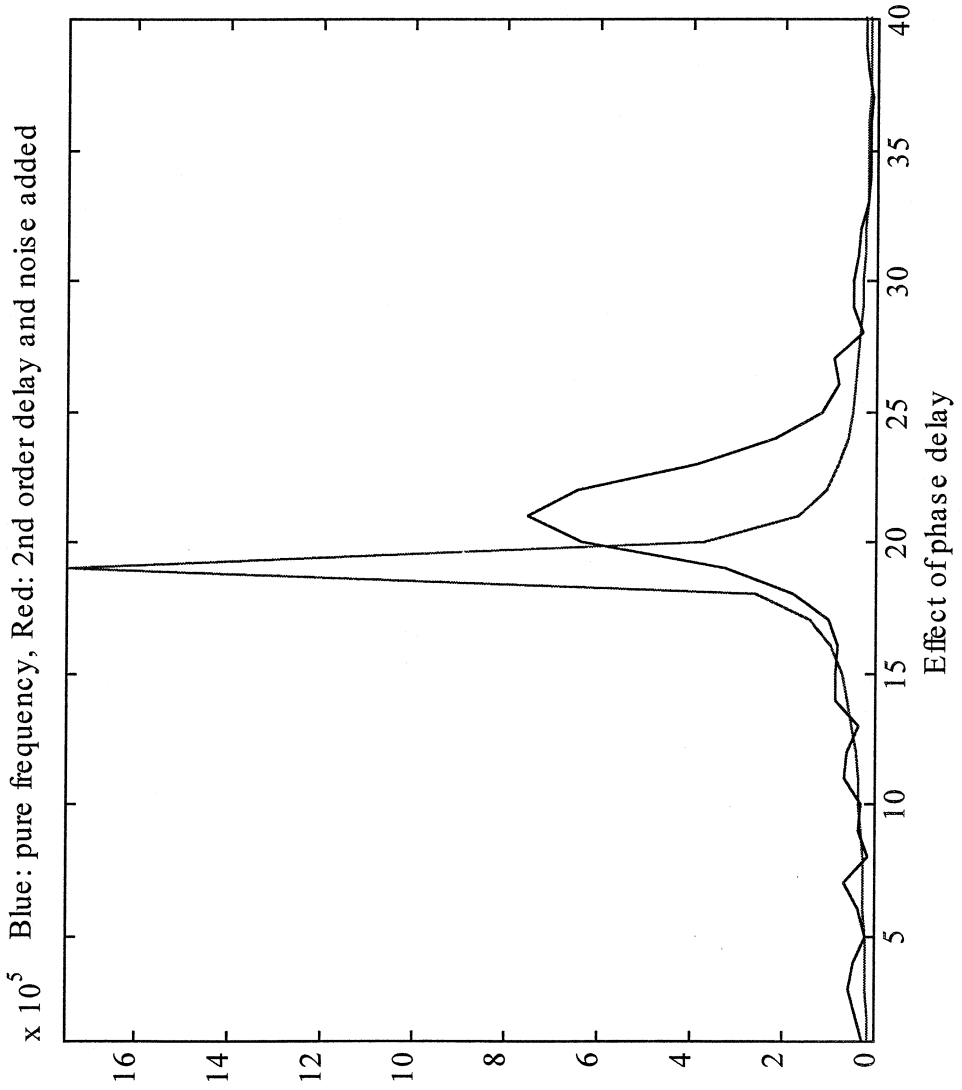

- ★ Simulated smearing of synthetic "skin" data
- ★ Amplitude reduced
- ★ Energy spread over multiple filters



RECEIVER AND PROCESSING CONCEPTS EVALUATION PROGRAM (RAPCEval)

Zoran Sevarlic
INTERIM
2001 MAY

CORRECTION OF PHASE ERRORS WITH AUTOFOCUS

x 10³ Blue: pure frequency, Red: 2nd & 3rd order delays and noise added

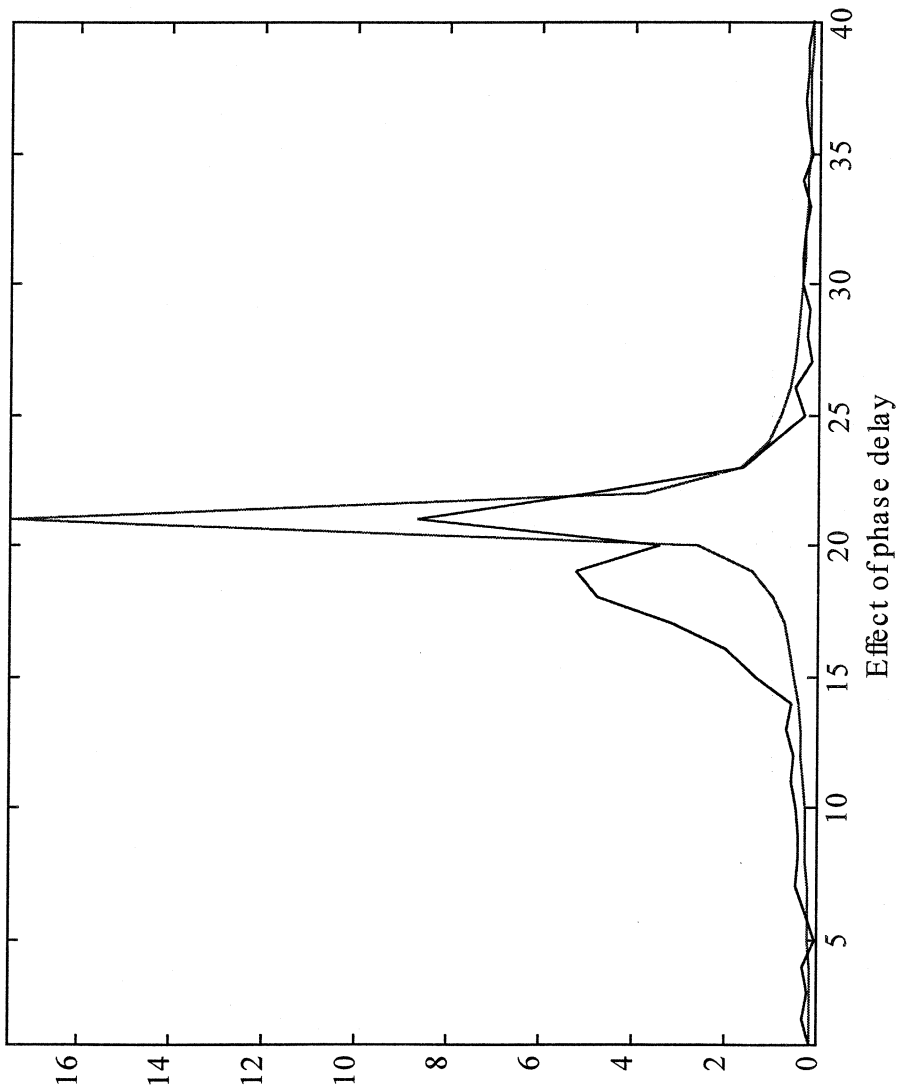

★ In addition to spreading, 3rd order "skews" the spreading



RECEIVER AND PROCESSING
CONCEPTS EVALUATION PROGRAM
(RAPCEval)

Zoran Sevarlic
INTERIM
2001 MAY

CORRECTION OF PHASE ERRORS WITH AUTOFOCUS

PHASE CHARACTERISTICS

- ★ Frequency is the derivative of phase and is analogous to LOS velocity
- ★ Slow targets have phase plots with smaller angles than fast ones
- ★ Constant velocity results in a phase plot with a constant slope
- ★ Changing velocity shows up as nonlinear phase
- ★ Acceleration is 2nd order phase nonlinearity
- ★ Jerk (derivative of acceleration) is 3rd order phase term



RECEIVER AND PROCESSING CONCEPTS EVALUATION PROGRAM (RAPCEval)

Zoran Sevarlic
INTERIM
2001 MAY

CORRECTION OF PHASE ERRORS WITH AUTOFOCUS

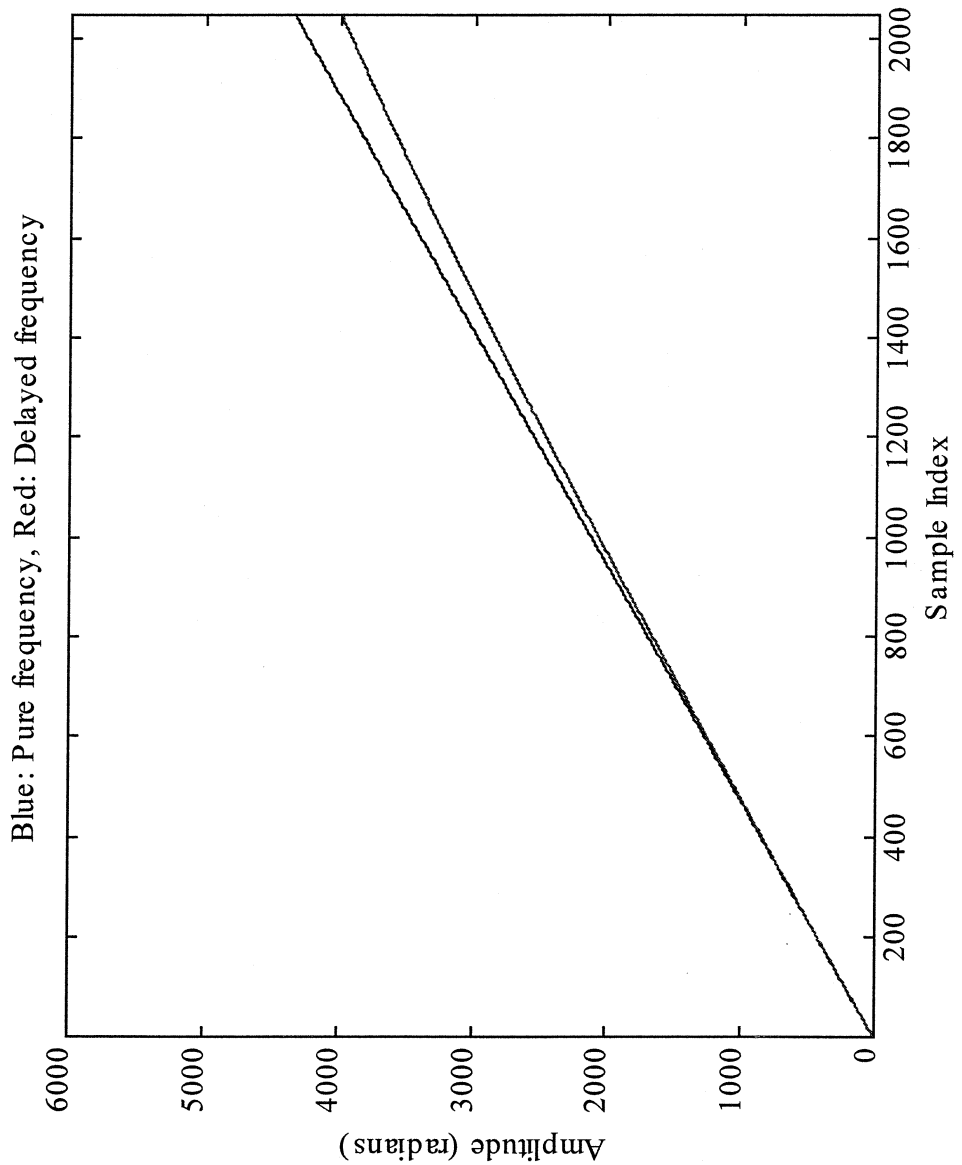

- ★ Trace of phase over time
- ★ Red line shows effects of non-linearity



RECEIVER AND PROCESSING CONCEPTS EVALUATION PROGRAM (RAPCEval)

Zoran Sevarlic
INTERIM
2001 MAY

CORRECTION OF PHASE ERRORS WITH AUTOFOCUS

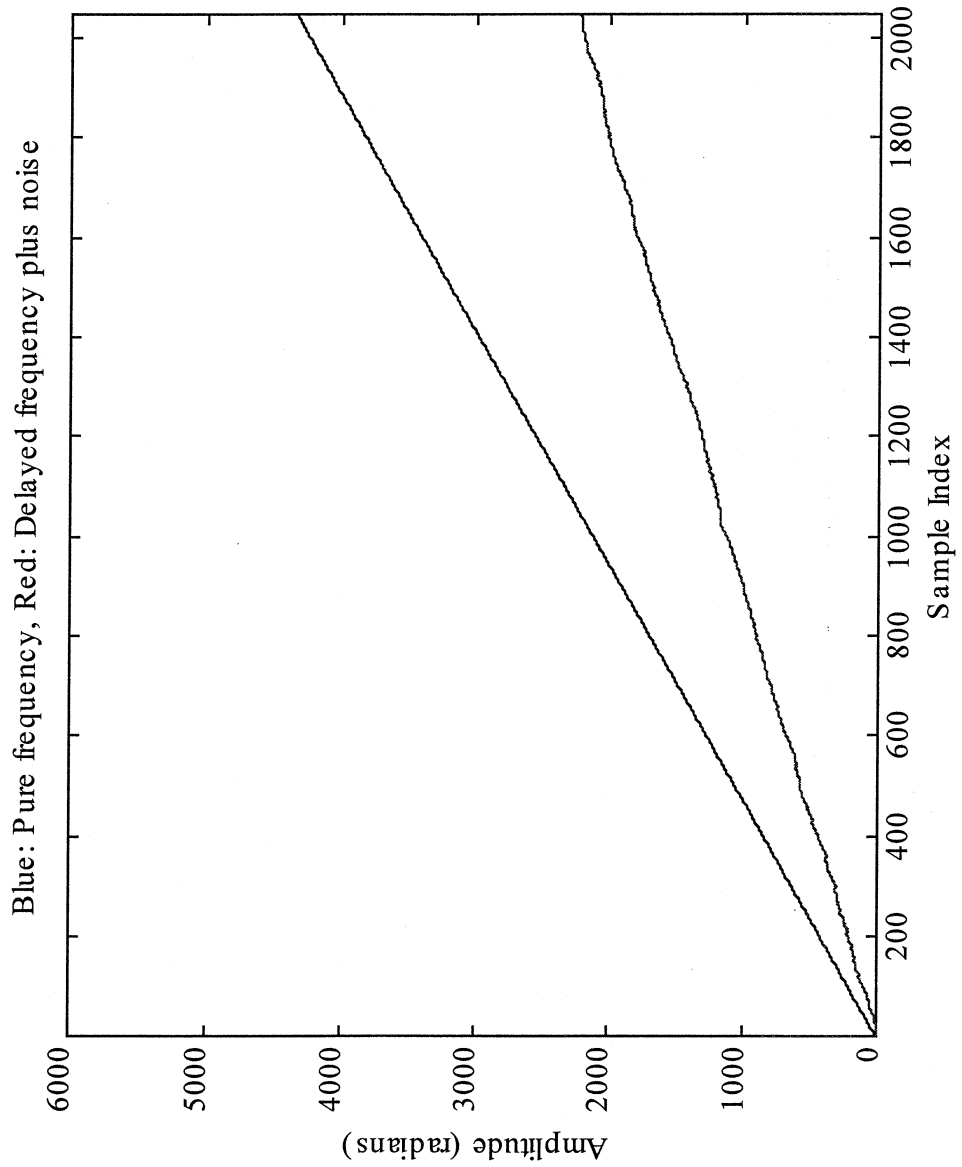



RECEIVER AND PROCESSING
CONCEPTS EVALUATION PROGRAM
(RAPCEval)

Zoran Sevarlic
INTERIM
2001 MAY

CORRECTION OF PHASE ERRORS WITH AUTOFOCUS

REAL DATA

- ★ Collection time: 70 ms Sampling rate: 30 KHz
- ★ 30 KHz/2048 filters = 15 Hz per filter
- ★ For X band: 1 ft/sec = 20 Hz
- ★ Change in velocity during 70 msec with $A = 1$ g:
 - $(32 \text{ ft/sec} / \text{sec}) \times 70 \text{ msec} = 2.24 \text{ ft/sec}$
- ★ Change in frequency:
 - $2.24 \text{ ft/sec} \times 20 \text{ Hz/ft/sec} = 44.8 \text{ Hz}$
- ★ Amount of smearing:
 - $44.8 \text{ Hz} \times 1 \text{ filter/15 Hz} = 3 \text{ filters}$



RECEIVER AND PROCESSING CONCEPTS EVALUATION PROGRAM (RAPCEval)

Zoran Sevarlic
INTERIM
2001 MAY

CORRECTION OF PHASE ERRORS WITH AUTOFOCUS

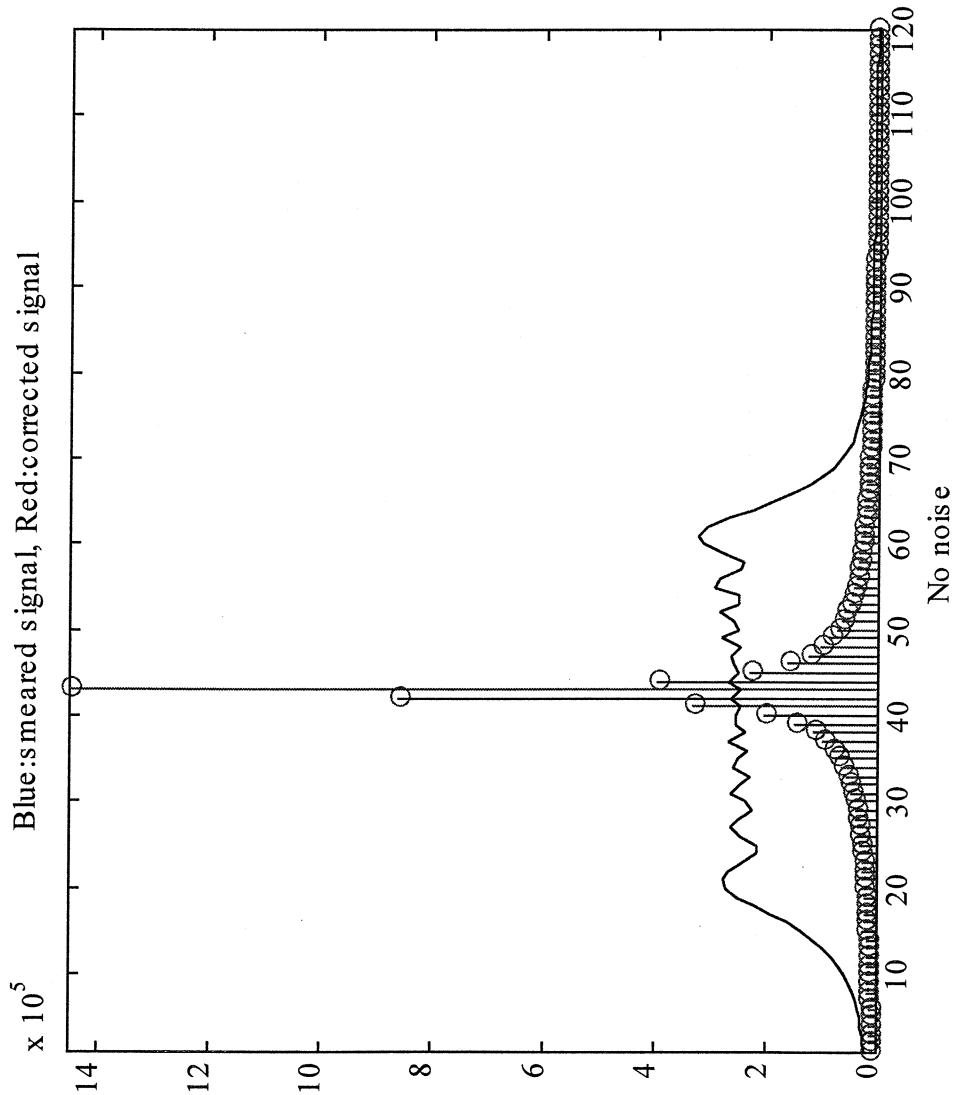

- ★ Synthetic data w/ exaggerated smearing
- ★ Calculate motion parameters (velocity, acceleration, jerk) from phase
- ★ Compensating for motion parameters yields correction (red)



RECEIVER AND PROCESSING CONCEPTS EVALUATION PROGRAM (RAPCEval)

Zoran Sevarlic
INTERIM
2001 MAY

CORRECTION OF PHASE ERRORS WITH AUTOFOCUS

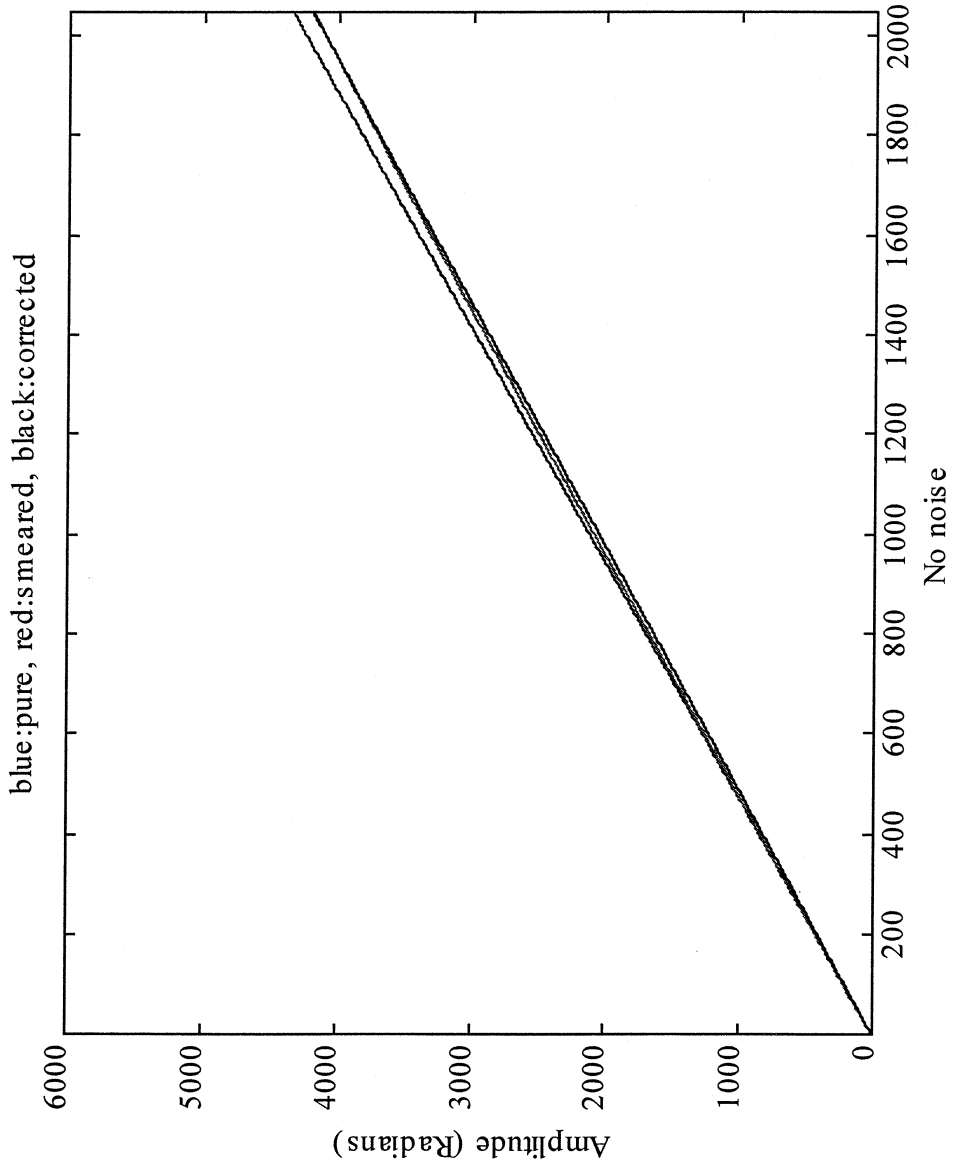

- ★ Synthetic data
- ★ Same signals as previous slide showing phase being “straightened out” after correction
- ★ Note: frequency is shifted for entire aperture



RECEIVER AND PROCESSING CONCEPTS EVALUATION PROGRAM (RAPCEval)

Zoran Sevarlic
INTERIM
2001 MAY

CORRECTION OF PHASE ERRORS WITH AUTOFOCUS

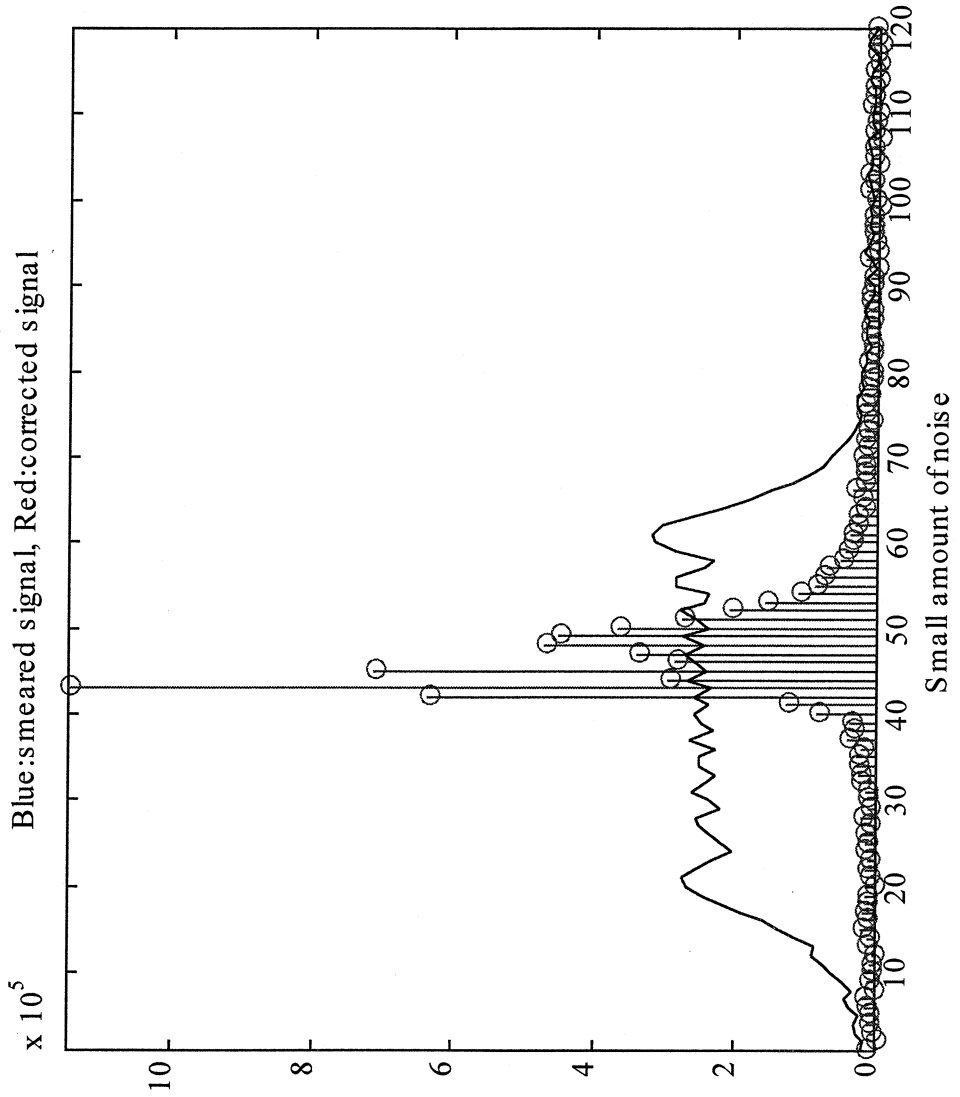

- ★ Synthetic data
- ★ Adding noise to model reduces the amount of correction



RECEIVER AND PROCESSING CONCEPTS EVALUATION PROGRAM (RAPCEval)

Zoran Sevarlic
INTERIM
2001 MAY

CORRECTION OF PHASE ERRORS WITH AUTOFOCUS

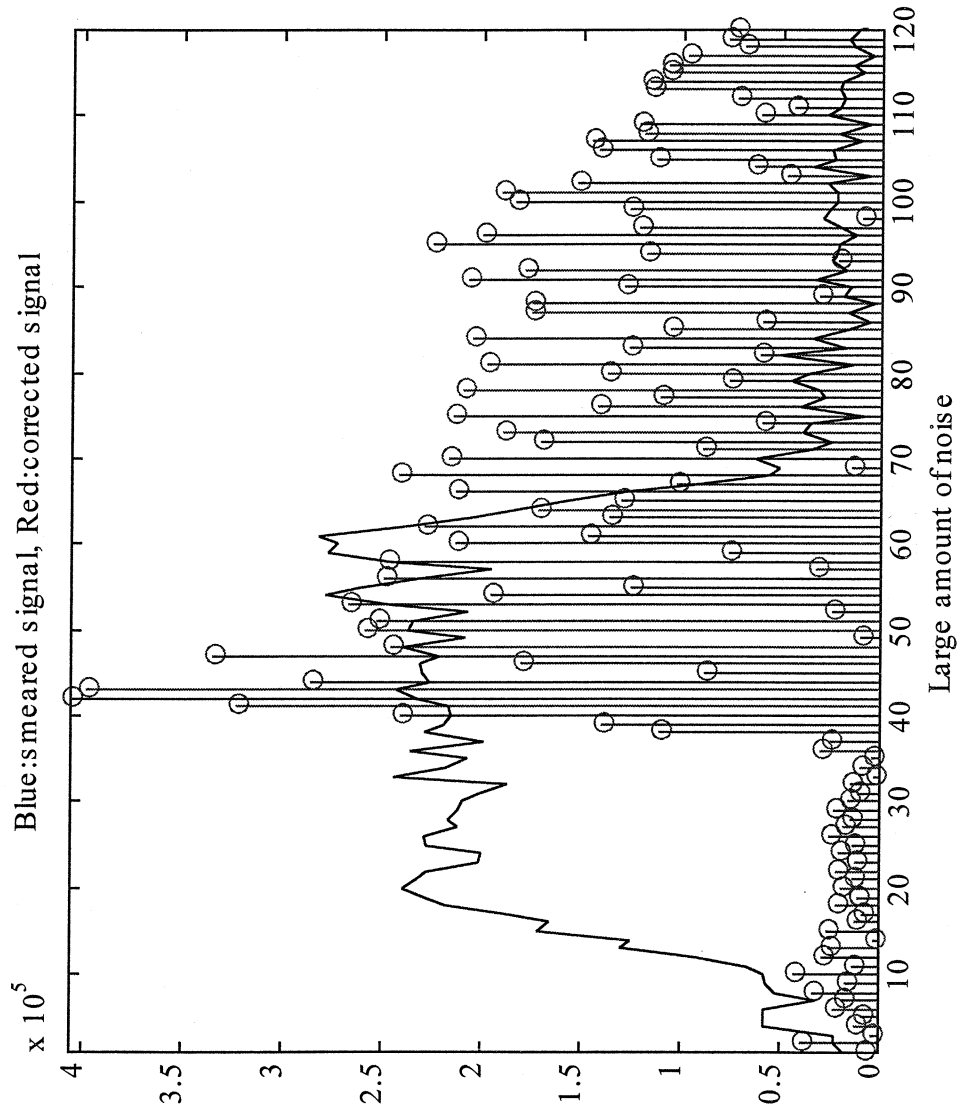

- ★ Synthetic data
- ★ Adding a large amount of noise causes algorithm to fail completely



RECEIVER AND PROCESSING CONCEPTS EVALUATION PROGRAM (RAPCEval)

Zoran Sevarlic
INTERIM
2001 MAY

CORRECTION OF PHASE ERRORS WITH AUTOFOCUS

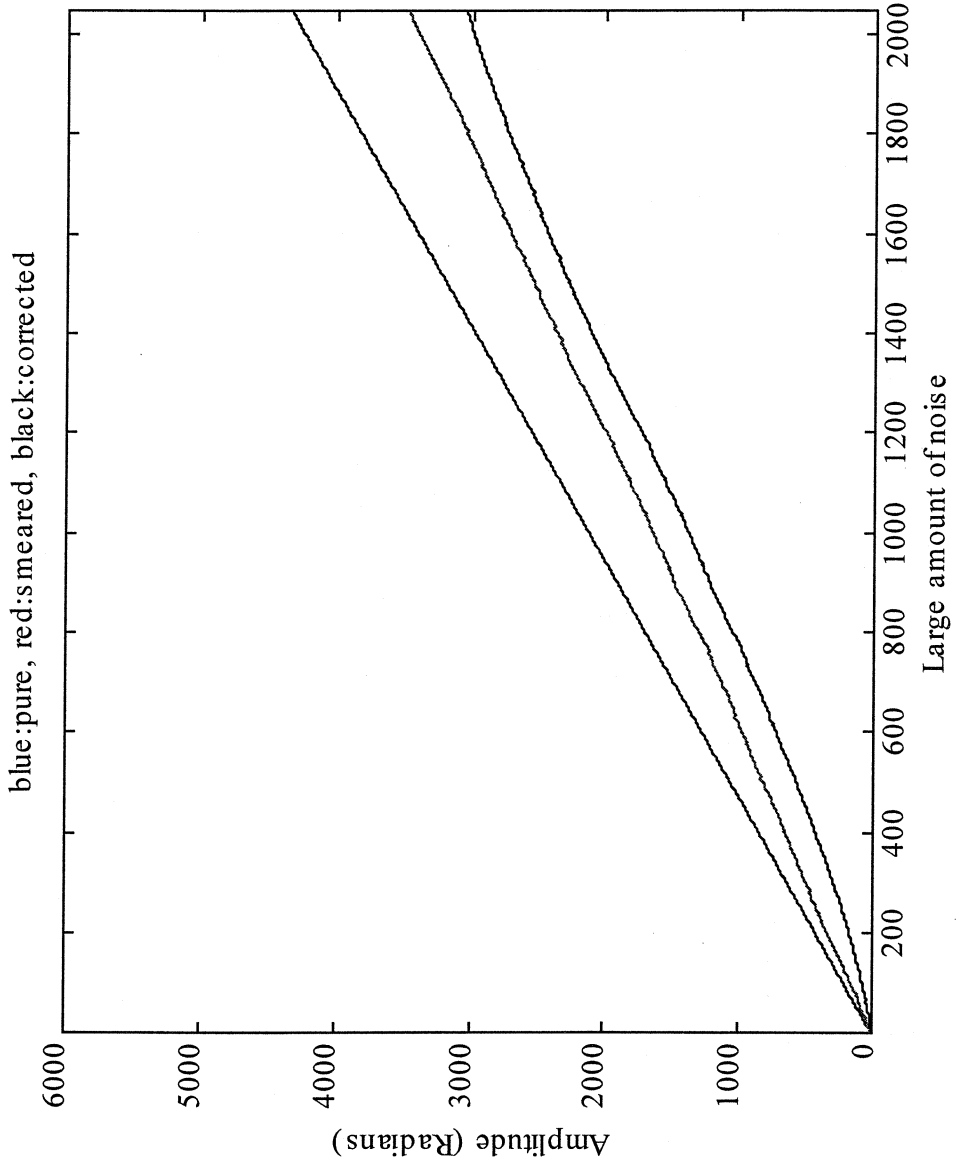

- ★ Synthetic data
- ★ Phase is now meaningless
- ★ Too much noise makes the phase information meaningless.



RECEIVER AND PROCESSING CONCEPTS EVALUATION PROGRAM (RAPCEval)

Zoran Sevarlic
INTERIM
2001 MAY

CORRECTION OF PHASE ERRORS WITH AUTOFOCUS

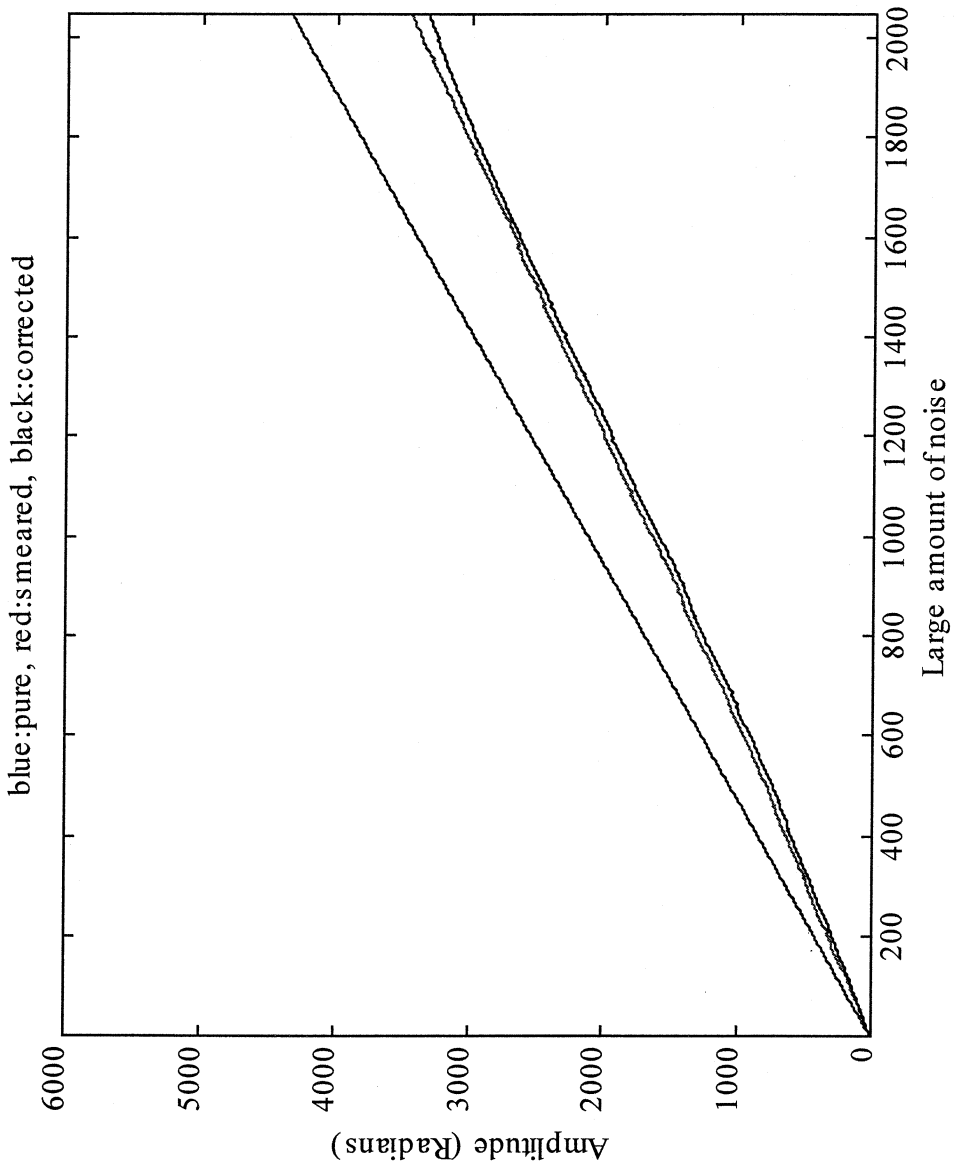

- ★ Synthetic data
- ★ Doing another run of the previous scenario shows how noisy phase causes random results



RECEIVER AND PROCESSING CONCEPTS EVALUATION PROGRAM (RAPCEval)

Zoran Sevarlic
INTERIM
2001 MAY

CORRECTION OF PHASE ERRORS WITH AUTOFOCUS

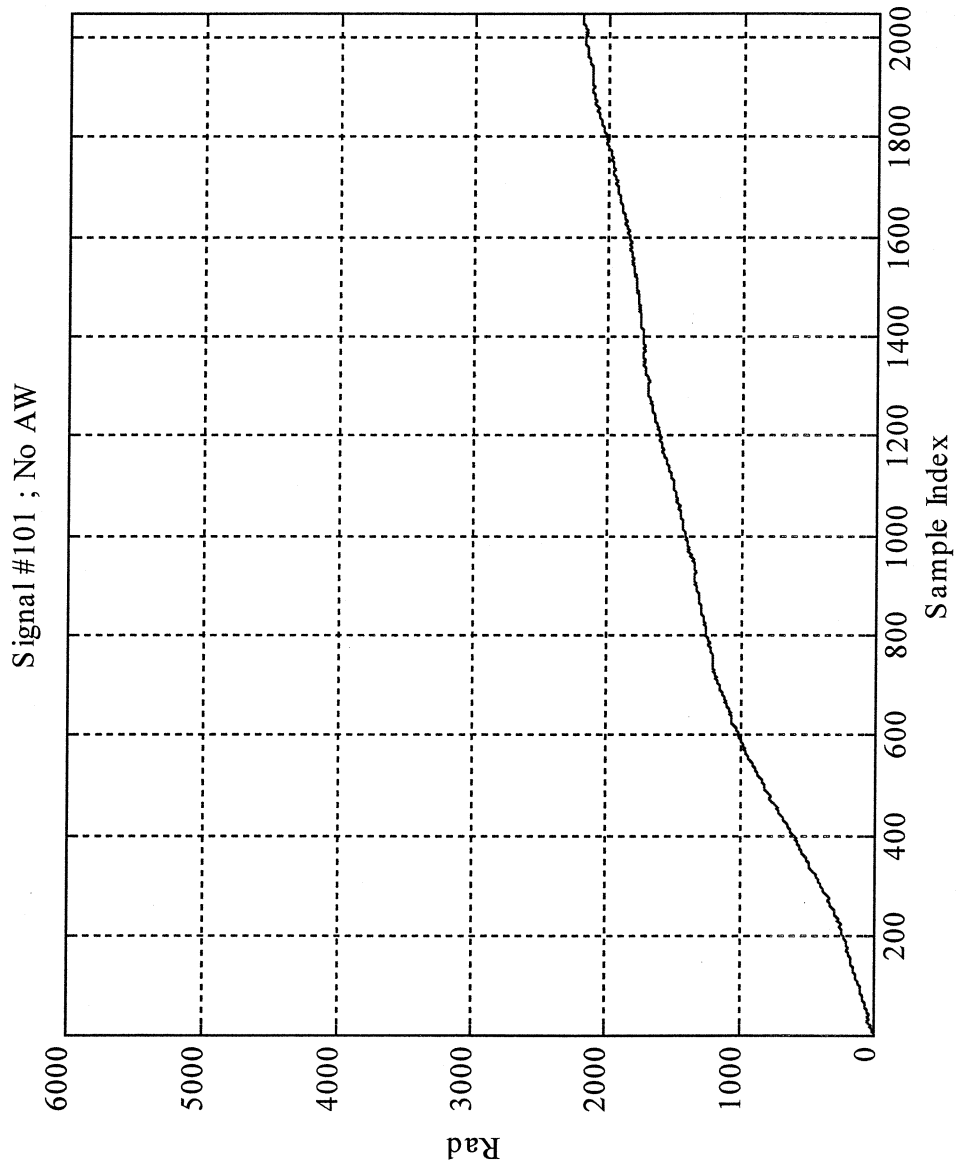

★ Real signal
showing noisy
phase



RECEIVER AND PROCESSING CONCEPTS EVALUATION PROGRAM (RAPCEval)

Zoran Sevarlic
INTERIM
2001 MAY

CORRECTION OF PHASE ERRORS WITH AUTOFOCUS

Signal #2106 ; No AW

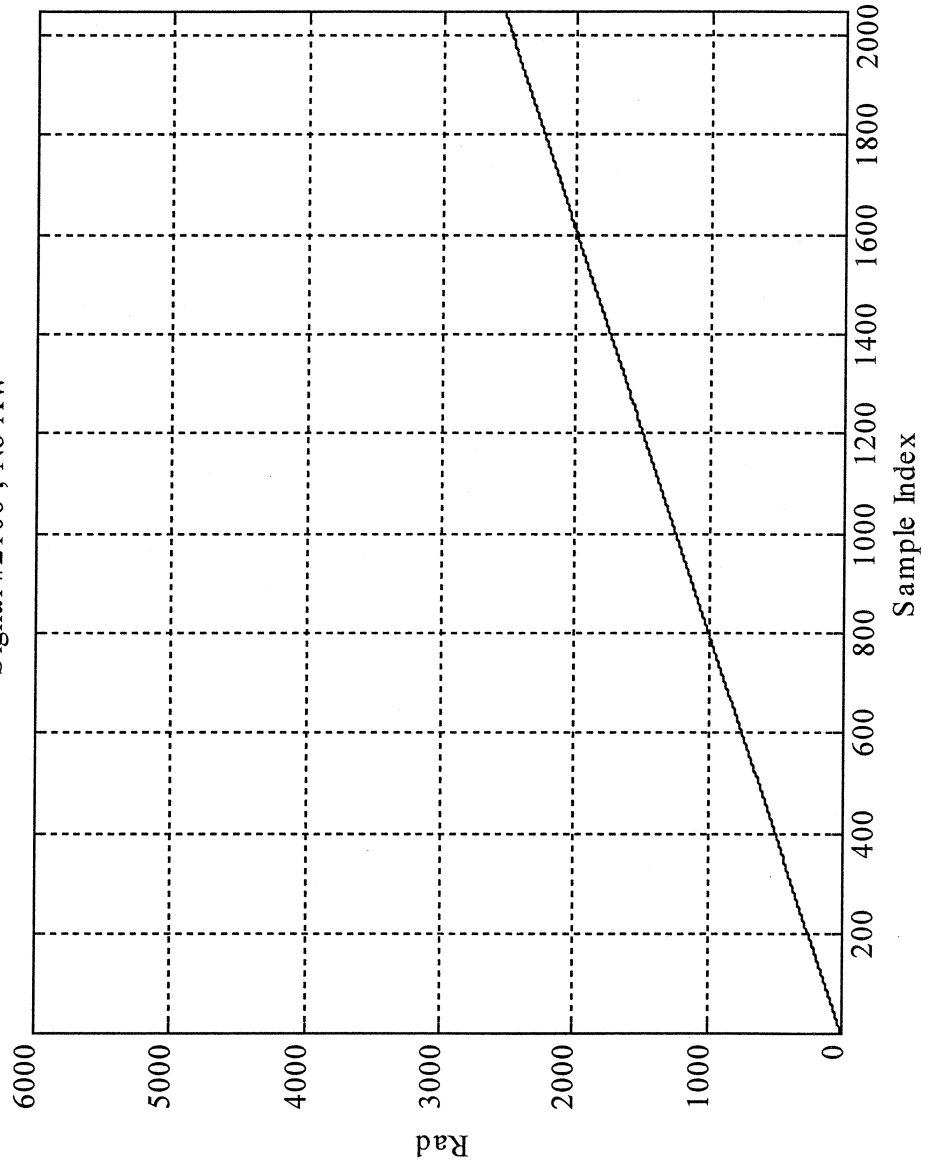

★ Real signal
showing "well-
behaved" phase



RECEIVER AND PROCESSING CONCEPTS EVALUATION PROGRAM (RAPCEval)

Zoran Sevarlic
INTERIM
2001 MAY

CORRECTION OF PHASE ERRORS WITH AUTOFOCUS

$\times 10^5$ Blue:orig Sig#2106; Maxfilter:405 ; No AW; BW=27 drift=-6

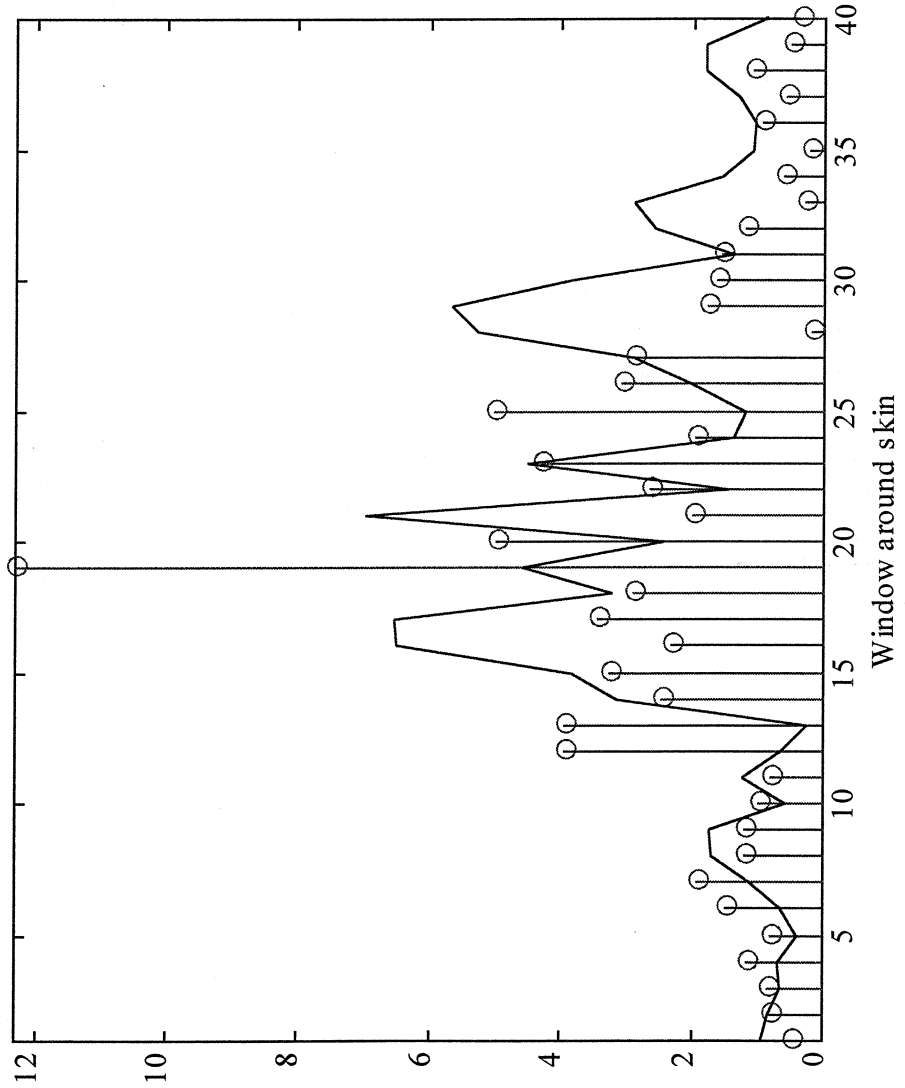

★ De-smearing of signal with well-behaved phase is possible using just the phase information



RECEIVER AND PROCESSING
CONCEPTS EVALUATION PROGRAM
(RAPCEval)

Zoran Sevarlic
INTERIM
2001 MAY

CORRECTION OF PHASE ERRORS WITH AUTOFOCUS

Signal #3125 ; No AW

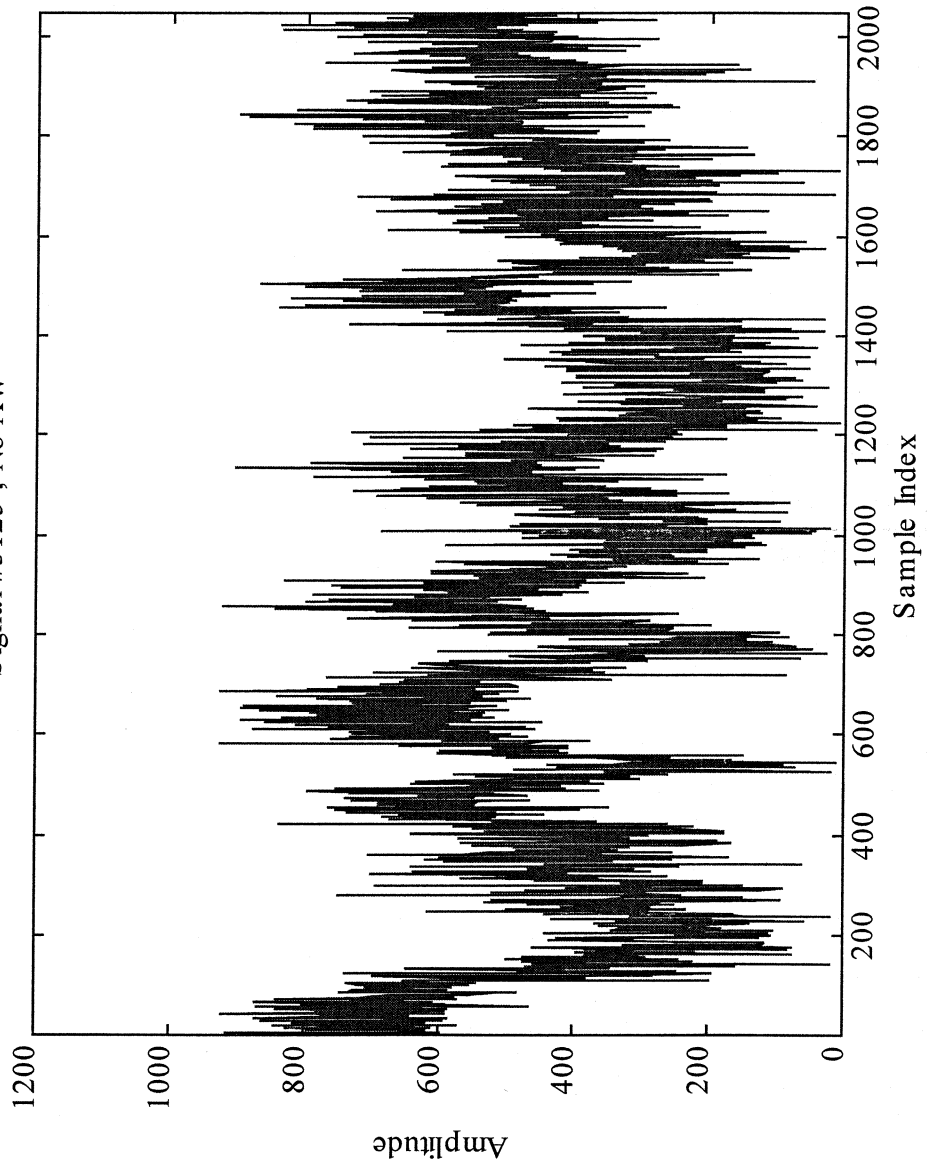

★ Amplitude of
typical real signal



RECEIVER AND PROCESSING
CONCEPTS EVALUATION PROGRAM
(RAPCEval)

Zoran Sevarlic
INTERIM
2001 MAY

CORRECTION OF PHASE ERRORS WITH AUTOFOCUS

Signal #2106 ; No AW

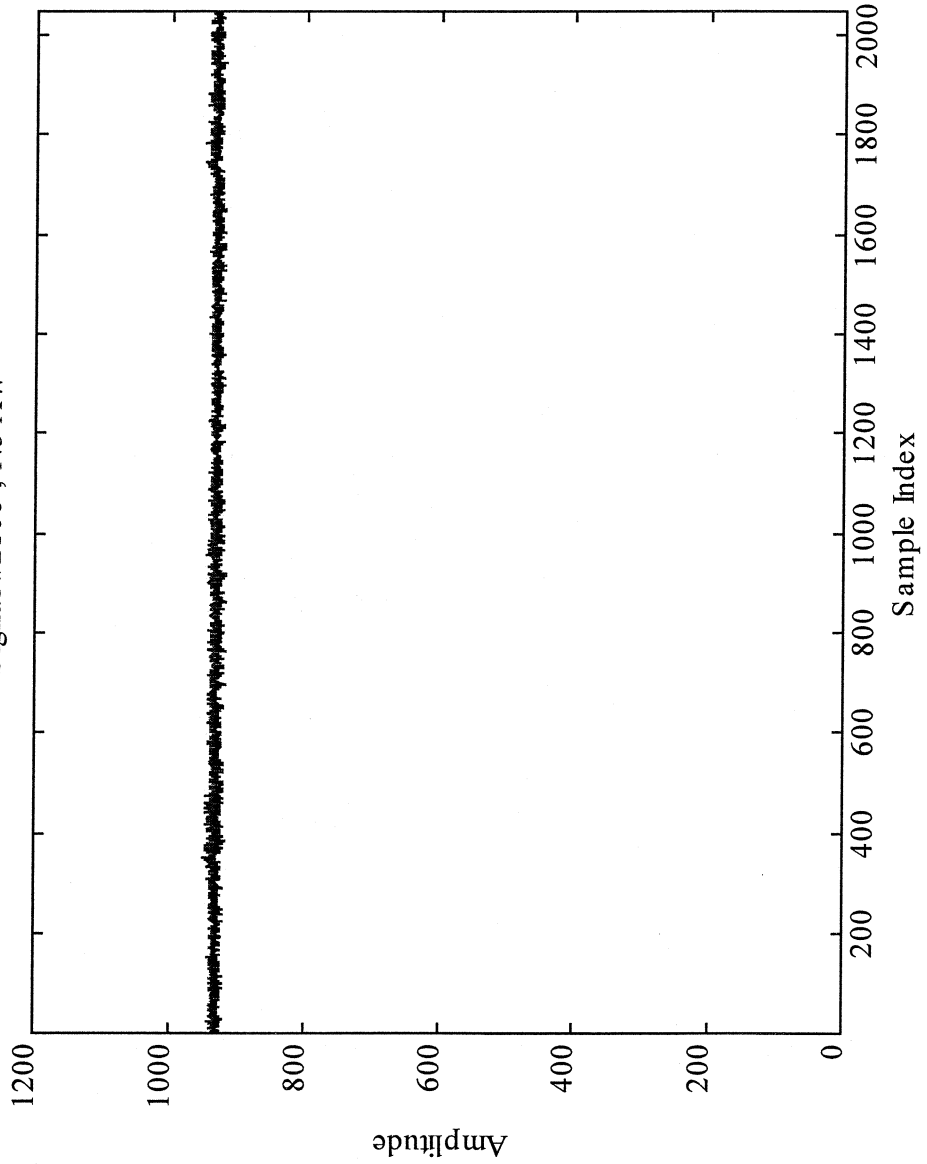

- ★ Amplitude of "well-behaved phase" signal
- ★ Phase is only well-behaved when the SNR is high



RECEIVER AND PROCESSING CONCEPTS EVALUATION PROGRAM (RAPCEval)

Zoran Sevarlic
INTERIM
2001 MAY

CORRECTION OF PHASE ERRORS WITH AUTOFOCUS

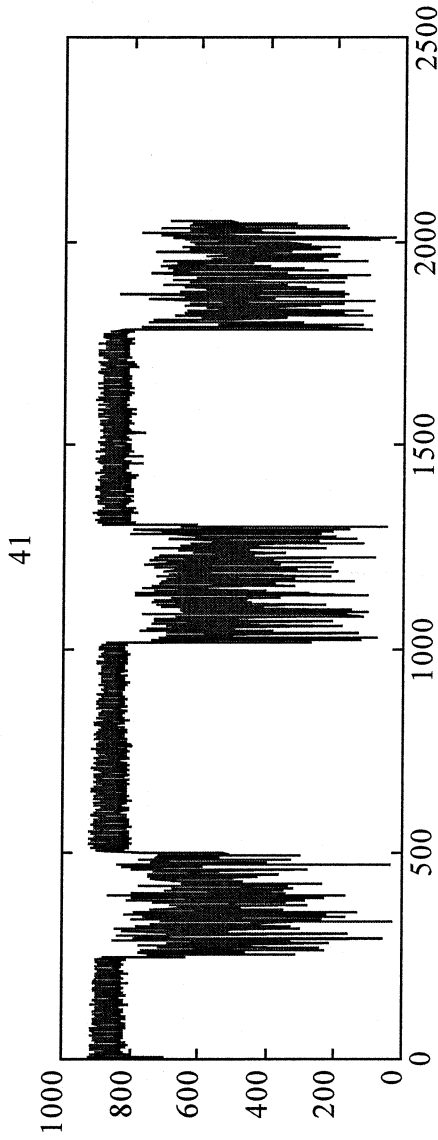

★ Amplitude and phase of real signal with "well-behaved" segments

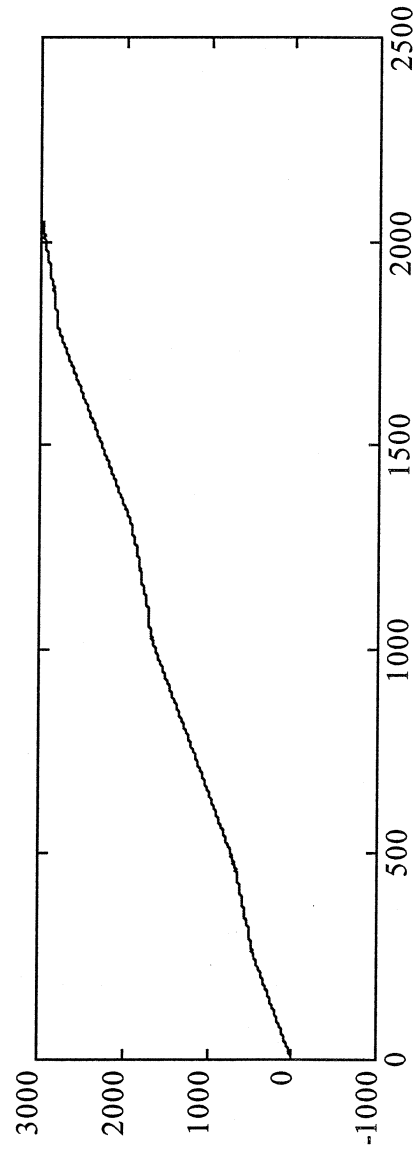



RECEIVER AND PROCESSING
CONCEPTS EVALUATION PROGRAM
(RAPCEval)

Zoran Sevarlic
INTERIM
2001 MAY

CORRECTION OF PHASE ERRORS WITH AUTOFOCUS

ADVANTAGES OF PHASE-ONLY TECHNIQUE

- ★ Some combination of noise filtering, phase unwrapping, and segmentation may yield acceptable results
- ★ Phase-only method is attractive as it does not require FFTs



RECEIVER AND PROCESSING
CONCEPTS EVALUATION PROGRAM
(RAPCEval)

Zoran Sevarlic
INTERIM
2001 MAY

CORRECTION OF PHASE ERRORS WITH AUTOFOCUS

PROBLEMS WITH PHASE-ONLY

- ★ Phase is usually too noisy
- ★ Noise greater than π from sample to sample requires unwrapping of the phase angle
- ★ Angle = $\arctan(I/Q)$ is discontinuous function
- ★ Computing phase requires calculating arctan of angles which is computationally intensive
- ★ Searching for well-behaved segments of phase requires additional processing time



RECEIVER AND PROCESSING
CONCEPTS EVALUATION PROGRAM
(RAPCEval)

Zoran Sevarlic
INTERIM
2001 MAY

CORRECTION OF PHASE ERRORS WITH AUTOFOCUS

PHASE GRADIENT

$$\text{Velocity: } \dot{\phi}(n) = \frac{\text{imag}(E^*(n) \dot{E}(n))}{|E(n)|^2}$$



RECEIVER AND PROCESSING
CONCEPTS EVALUATION PROGRAM
(RAPCEval)

Zoran Sevarlic
INTERIM
2001 MAY

CORRECTION OF PHASE ERRORS WITH AUTOFOCUS

PHASE GRADIENT

- ★ An alternative way of deriving frequency information is to use the phase gradient technique
- ★ Advantages:
 - Continuous function (no need for unwrapping)
 - No arctan calculations
- ★ Disadvantages:
 - May require filtering to reduce noise
- ★ May be tried in Matlab if time permits



RECEIVER AND PROCESSING
CONCEPTS EVALUATION PROGRAM
(RAPCEval)

Zoran Sevarlic
INTERIM
2001 MAY

CORRECTION OF PHASE ERRORS WITH AUTOFOCUS

BASIC AUTOFOCUS ALGORITHM

- ★ Step 1: Calculate motion parameters C (2nd order acceleration) and D (3rd order jerk)
- Autofocus techniques differ in this first step

- ★ Step 2: Compensate for motion:

$$\text{exp2} = \exp(j * 2 * \pi * C * i * i) ;$$

$$\text{exp3} = \exp(j * 2 * \pi * D * i * i * i) ;$$

$$\text{corrected}(i) = \text{iq}(i) * \text{exp2} * \text{exp3} ;$$

Compensation step is common to all techniques



RECEIVER AND PROCESSING
CONCEPTS EVALUATION PROGRAM
(RAPCEval)

Zoran Sevarlic
INTERIM
2001 MAY

CORRECTION OF PHASE ERRORS WITH AUTOFOCUS

PHASE DIFFERENCE TECHNIQUE

- ★ For 2048 I and Q samples, divide into three overlapping 1024 samples subapertures X, Y, Z
- ★ Form two complex subaperture products X^*Y and Y^*Z
- ★ Perform FFTs: $\text{FFT}(X^*Y)$ and $\text{FFT}(Y^*Z)$
- ★ Measure shift in spectrum peaks (T1, T2)
- ★ Compute phase error coefficients (C, D) from:

$$C = (T1+T2) / (4 * (512) * (1024)) ;$$

$$D = (T1-T2) / (6 * (512) * (1024)) ;$$



RECEIVER AND PROCESSING CONCEPTS EVALUATION PROGRAM (RAPCEval)

Zoran Sevarlic
INTERIM
2001 MAY

CORRECTION OF PHASE ERRORS WITH AUTOFOCUS

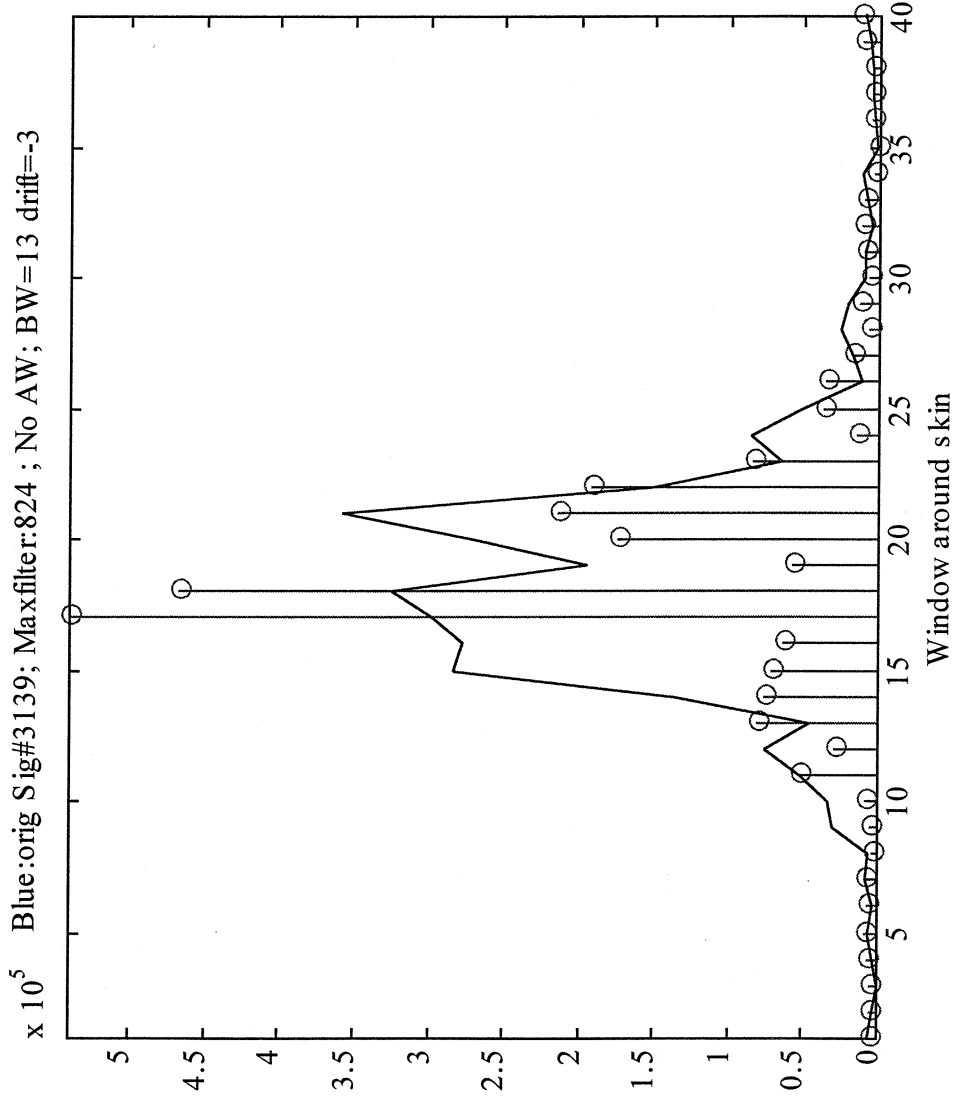

★ Real signal (blue)
shown with
correction (red)
using phase
difference
technique



RECEIVER AND PROCESSING
CONCEPTS EVALUATION PROGRAM
(RAPCEval)

Zoran Sevarlic
INTERIM
2001 MAY

CORRECTION OF PHASE ERRORS WITH AUTOFOCUS

PHASE DIFFERENCE

- ★ Advantages:
 - Works best on SAR maps with no prominent point
 - Requires 2 FFTs for 2nd and 3rd order correction
- ★ Disadvantages:
 - Can be thrown off by noisy multiple prominent points
 - Filtering sometimes required to improve results



RECEIVER AND PROCESSING
CONCEPTS EVALUATION PROGRAM
(RAPCEval)

Zoran Sevarlic
INTERIM
2001 MAY

CORRECTION OF PHASE ERRORS WITH AUTOFOCUS

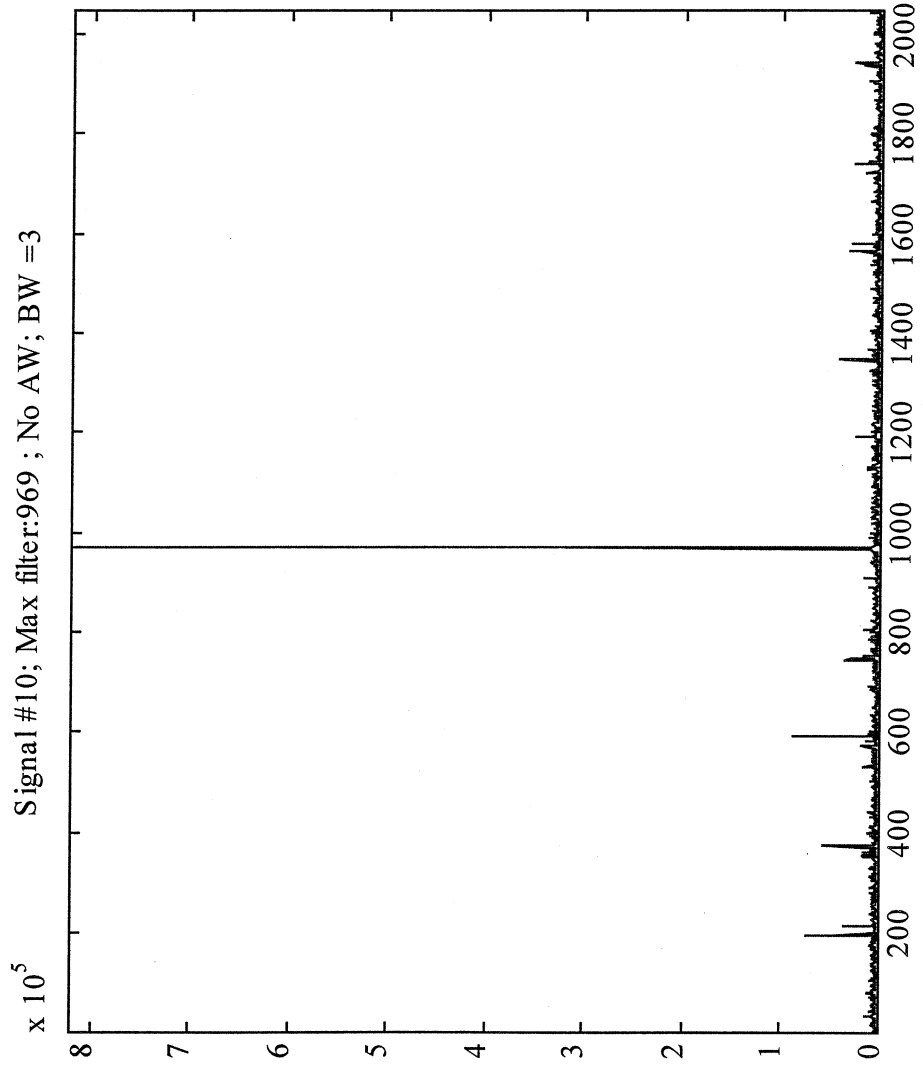



RECEIVER AND PROCESSING CONCEPTS EVALUATION PROGRAM (RAPCEval)

Zoran Sevarlic
INTERIM
2001 MAY

CORRECTION OF PHASE ERRORS WITH AUTOFOCUS

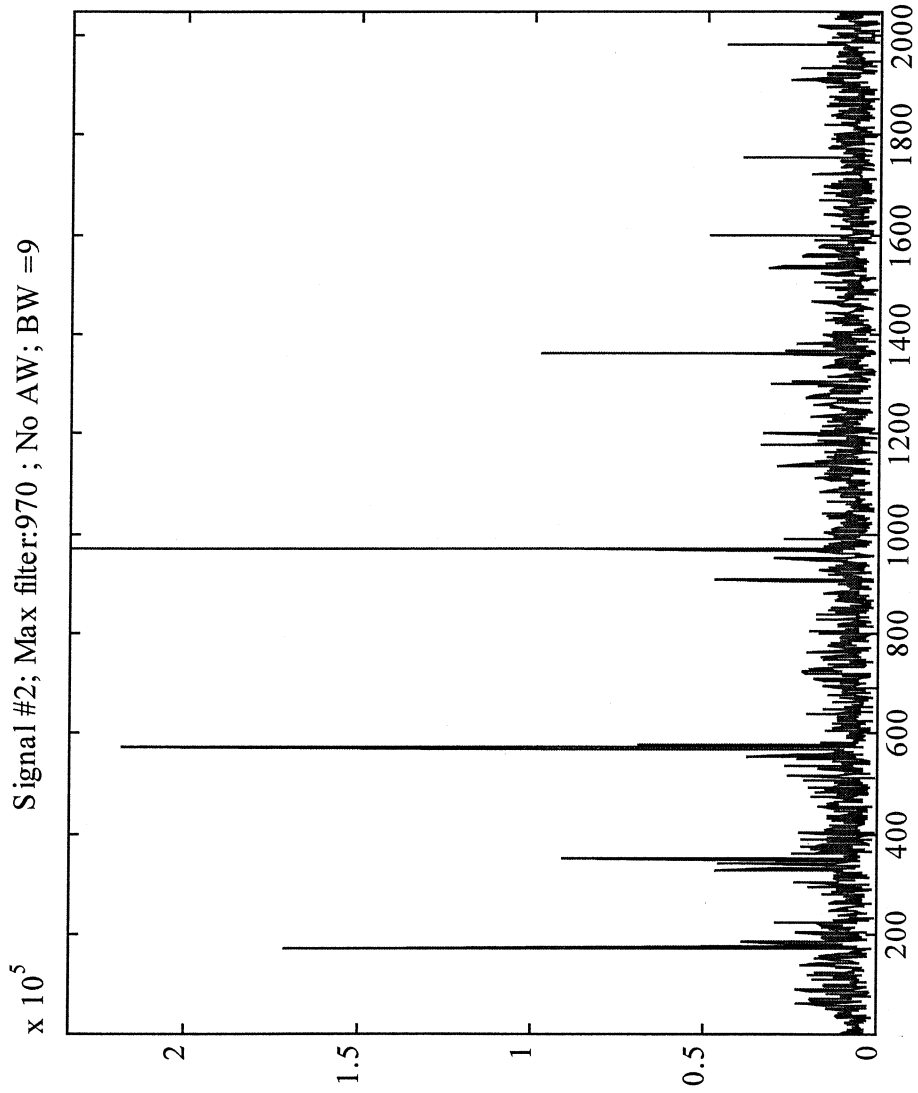

★ PSD of another
signal showing
multiple
prominent points
which are subject
to “jitter”



RECEIVER AND PROCESSING CONCEPTS EVALUATION PROGRAM (RAPCEval)

Zoran Sevarlic
INTERIM
2001 MAY

CORRECTION OF PHASE ERRORS WITH AUTOFOCUS

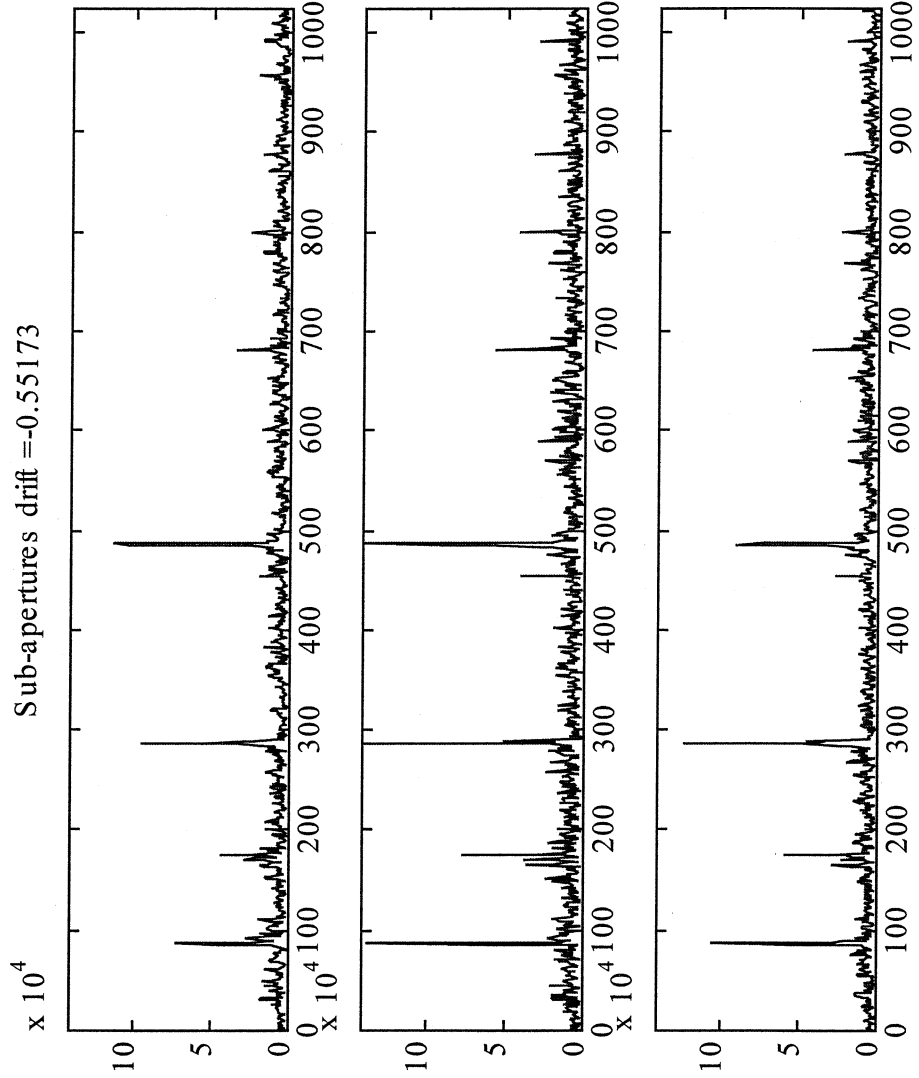

★ 3 subapertures of
previous signal
showing what
jitter does to the
prominent point



RECEIVER AND PROCESSING CONCEPTS EVALUATION PROGRAM (RAPCEval)

Zoran Sevarlic
INTERIM
2001 MAY

CORRECTION OF PHASE ERRORS WITH AUTOFOCUS

TECHNIQUE FAVORED

- ★ Most promising technique takes advantage of the following:
 - Target returns signals that contain very prominent skin
 - The prominent point exhibits a drift over time which corresponds to the target maneuver
- ★ This hybrid approach does not require filtering of noise since prominent point is so much greater than noise
- ★ Instead of filtering, windowing is used to isolate prominent point



RECEIVER AND PROCESSING
CONCEPTS EVALUATION PROGRAM
(RAPCEval)

Zoran Sevarlic
INTERIM
2001 MAY

CORRECTION OF PHASE ERRORS WITH AUTOFOCUS

HYBRID TECHNIQUE

- ★ Hybrid of Map Drift technique and Prominent Point Processing Technique
- ★ Normal Prominent Point technique finds the path of the prominent point over the entire aperture thus requiring many FFTs
- ★ Since computing 2nd and 3rd order motion parameters only requires 3 points in time, hybrid technique uses only 3 FFTs
- ★ Hybrid technique would probably not work on SAR maps with no prominent points



RECEIVER AND PROCESSING CONCEPTS EVALUATION PROGRAM (RAPCEval)

Zoran Sevarlic
INTERIM
2001 MAY

CORRECTION OF PHASE ERRORS WITH AUTOFOCUS

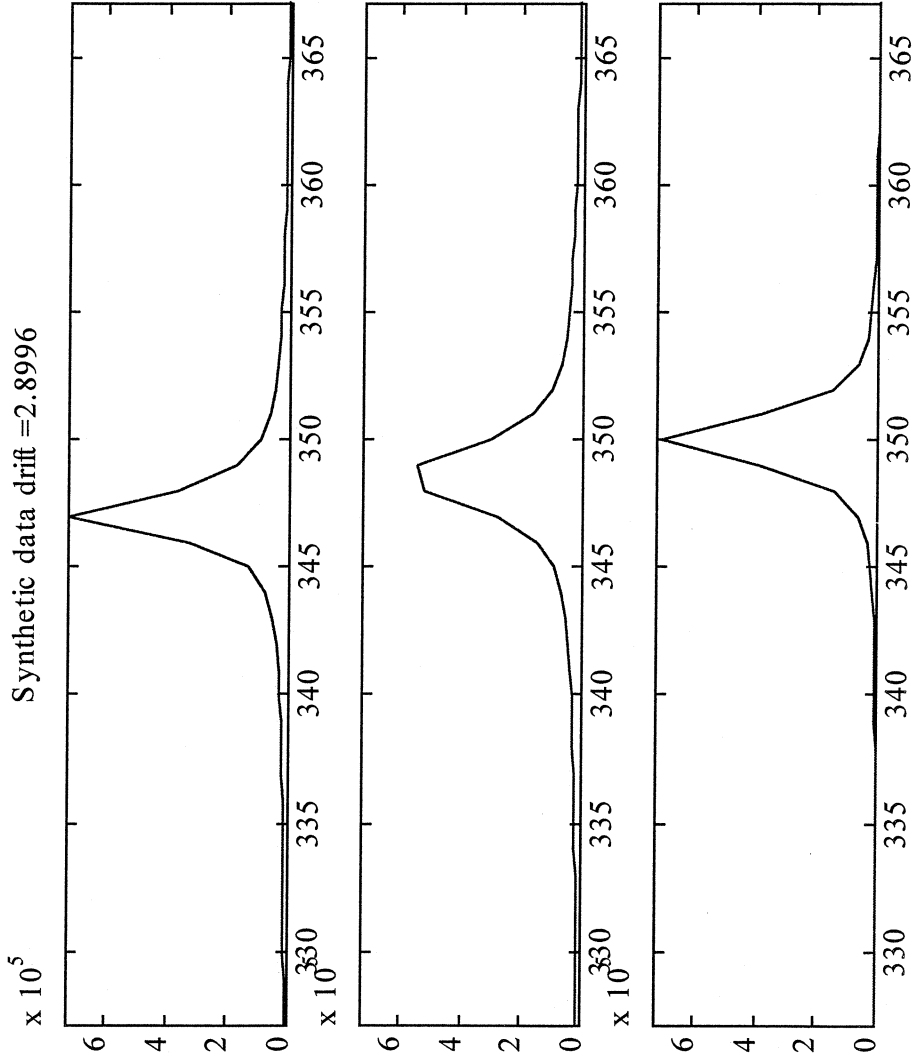

1. Take FFTs of three overlapping subapertures
2. Compute frequency drift (offset)
3. Derive C and D motion parameters from this drift



RECEIVER AND PROCESSING CONCEPTS EVALUATION PROGRAM (RAPCEval)

Zoran Sevarlic
INTERIM
2001 MAY

CORRECTION OF PHASE ERRORS WITH AUTOFOCUS

$\times 10^5$ Blue:orig Sig#Syn; Maxfilter:694 ; No AW; BW=15 drift=-2

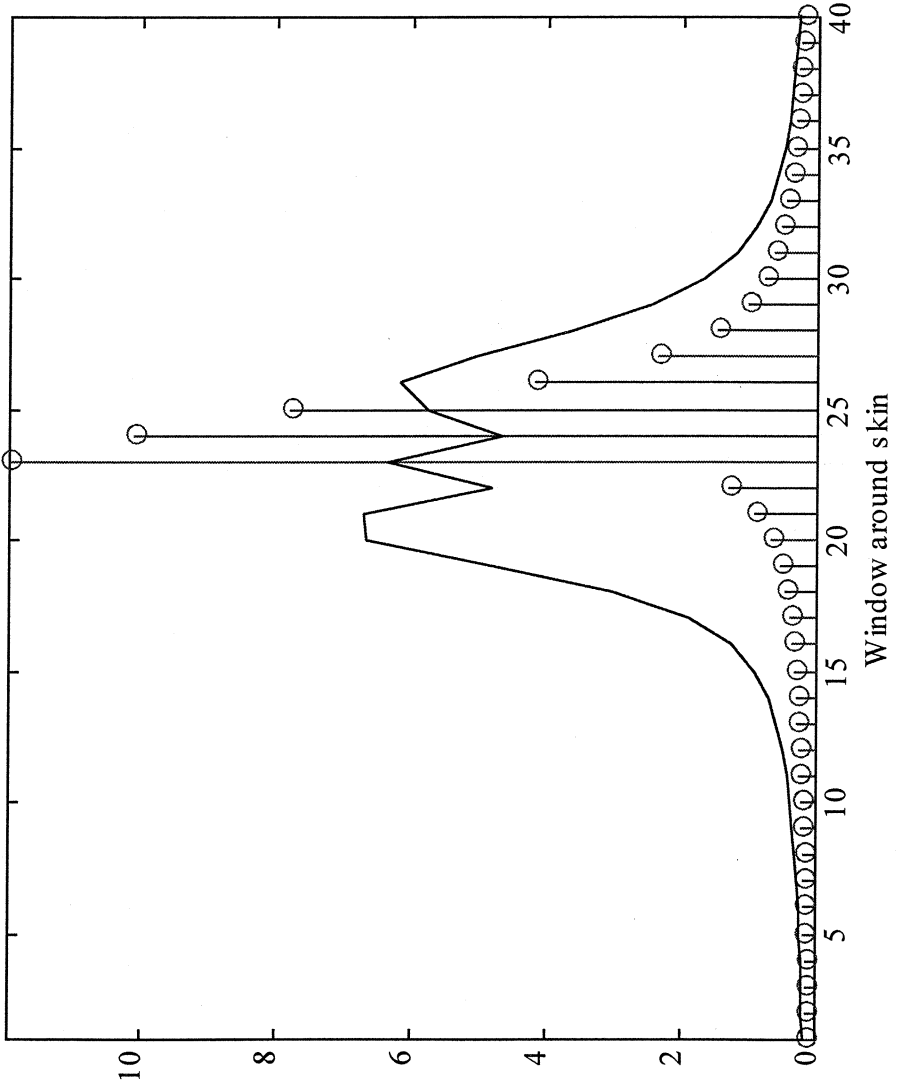

★ Result of
applying
correction (red)
for synthetic data
using "hybrid"
technique



RECEIVER AND PROCESSING CONCEPTS EVALUATION PROGRAM (RAPCEval)

Zoran Sevarlic
INTERIM
2001 MAY

CORRECTION OF PHASE ERRORS WITH AUTOFOCUS

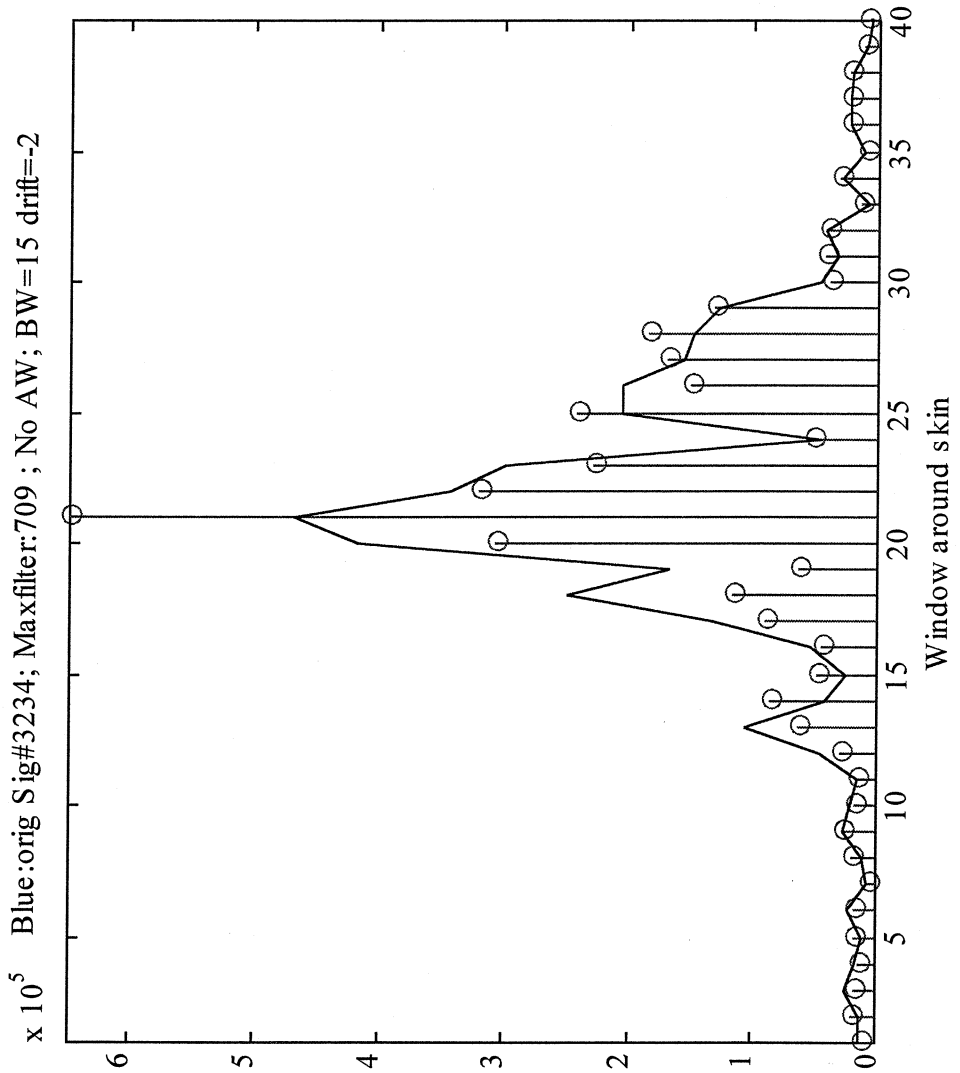

★ Result of
applying
technique to real
data using
“hybrid”
technique



RECEIVER AND PROCESSING
CONCEPTS EVALUATION PROGRAM
(RAPCEval)

Zoran Sevarlic
INTERIM
2001 MAY

CORRECTION OF PHASE ERRORS WITH AUTOFOCUS

MEASURING SMEARING

- ★ Measure BW using the 95% signal energy method
- ★ Measure drift of frequency over collection time
- ★ Measure signal bandwidth (BW) using the -3 dB method



**RECEIVER AND PROCESSING
CONCEPTS EVALUATION PROGRAM
(RAPCEval)**

Zoran Sevarlic
INTERIM
2001 MAY

CORRECTION OF PHASE ERRORS WITH AUTOFOCUS

COMPARING RESULTS

(70 signals)	Hybrid	Phase diff.
% amp better	35.71%	34.42%
% amp worse	14.28%	22.85%
% amp much better	8.57%	11.42%
% amp much worse	1.42%	11.42%



RECEIVER AND PROCESSING
CONCEPTS EVALUATION PROGRAM
(RAPCEval)

Zoran Sevarlic
INTERIM
2001 MAY

CORRECTION OF PHASE ERRORS WITH AUTOFOCUS

EMULATION

- ★ “Hybrid” technique has just been implemented in WR emulator
- ★ Results compare with MATLAB results
- ★ Preliminary testing with large numbers of signals is promising but much more testing and analysis is needed



RECEIVER AND PROCESSING
CONCEPTS EVALUATION PROGRAM
(RAPCEval)

Zoran Sevarlic
INTERIM
2001 MAY

CORRECTION OF PHASE ERRORS WITH AUTOFOCUS

CONCLUSIONS

- ★ Three autofocus techniques have been successfully implemented in MATLAB
- Hybrid prominent point technique appears to be the most promising
- ★ One autofocus technique (“hybrid”) has been successfully implemented in the emulator
- ★ Observation:
 - Not all “smearing” is caused by maneuvers



RECEIVER AND PROCESSING CONCEPTS EVALUATION PROGRAM (RAPCEval)

Zoran Sevarlic
INTERIM
2001 MAY

CORRECTION OF PHASE ERRORS WITH AUTOFOCUS

NEXT STEPS

- ★ More testing with MATLAB simulation
- ★ Statistical analysis of results
- ★ More testing with emulator (estimate the % of samples with significant target/ownship maneuver vs. % improvement)
- ★ Time permitting:
 - Implement phase gradient in MATLAB
 - Explain cases where algorithm appears not to work
 - Find solution or check conditions before application, if possible
 - Identify other causes of smearing
 - Find better method of measuring prominent point centroid



**RECEIVER AND PROCESSING
CONCEPTS EVALUATION PROGRAM
(RAPCEval)**

Zoran Sevarlic
INTERIM
2001 MAY

CORRECTION OF PHASE ERRORS WITH AUTOFOCUS

FURTHER RESEARCH

- ★ A good phase unwrapping technique is needed
- ★ Find filtering methods that reduce noise for better calculation of motion parameters
- ★ Determine sources of and ways to improve smearing caused by other phenomena

5.1.8 Presentation by Bill Elliott

The student briefing presented by Bill Elliott at this meeting is reproduced on the next 20 pages.



**RF RECEIVER AND PROCESSING
CONCEPTS EVALUATION PROGRAM
(RAPCEval)**

R. Elliott
FINAL
05/3/2001

**A MODIFIED NEAR-FIELD TECHNIQUE
FOR SUPPORTING THE
PHASED-ARRAY ANTENNA SYSTEM**

Richard W. Elliott, Jr.

WR-ALC/LYSTD
Robins AFB, GA



**RF RECEIVER AND PROCESSING
CONCEPTS EVALUATION PROGRAM
(RAPCEval)**

R. Elliott
FINAL
05/3/2001

**A MODIFIED NEAR-FIELD TECHNIQUE FOR SUPPORTING
THE PHASED-ARRAY ANTENNA SYSTEM**

PROBLEM STATEMENT

We are not detecting many Phased-Array Antenna System (PAAS) faults in the field due to the limited testing capability available in the field.



RF RECEIVER AND PROCESSING CONCEPTS EVALUATION PROGRAM (RAPCEval)

R. Elliott
FINAL
05/3/2001

Change with Faulty Element

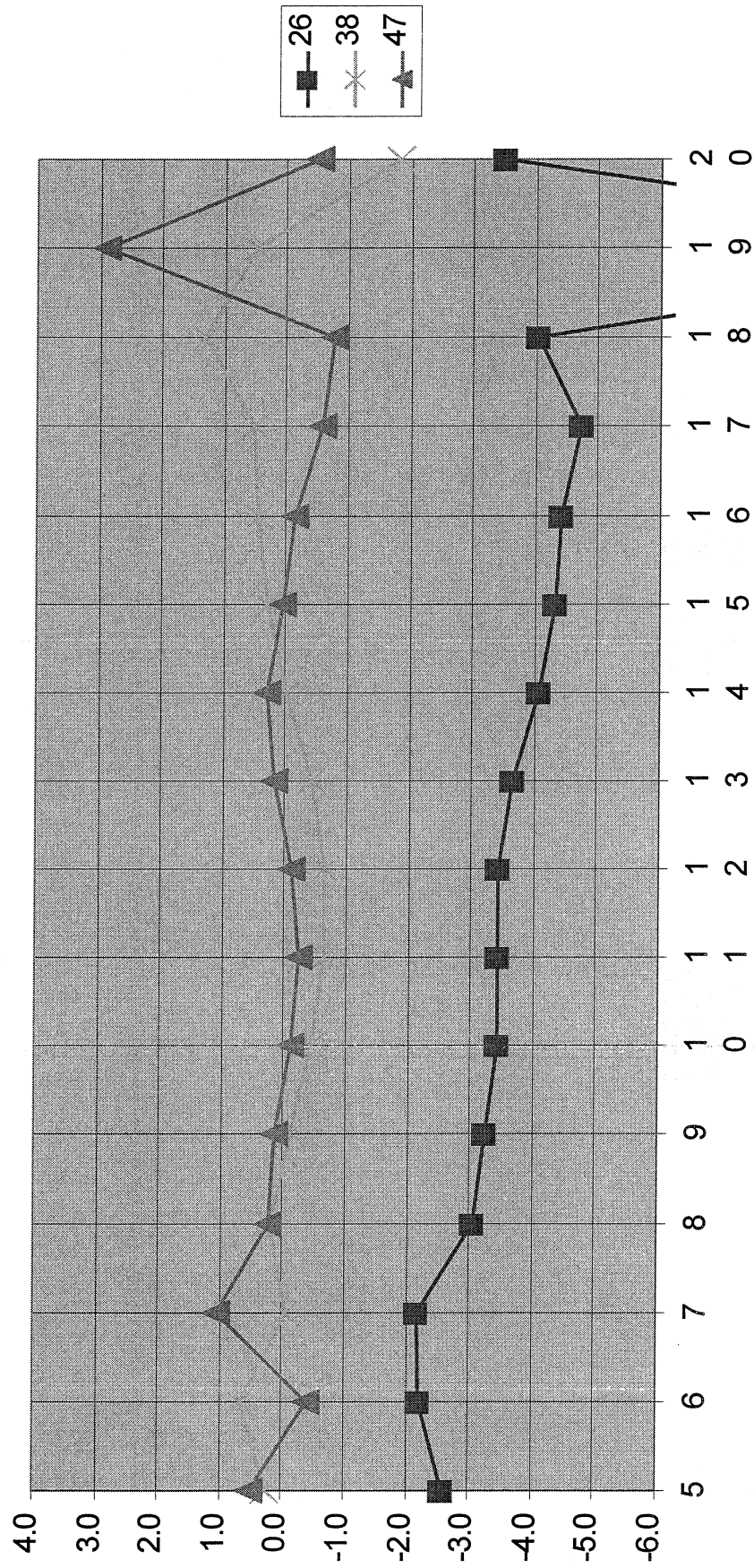



RF RECEIVER AND PROCESSING
CONCEPTS EVALUATION PROGRAM
(RAPCEval)

R. Elliott
FINAL
05/3/2001

A MODIFIED NEAR-FIELD TECHNIQUE FOR SUPPORTING
THE PHASED-ARRAY ANTENNA SYSTEM

PROPOSED METHOD OF INVESTIGATION

- ★ NEC-4 Software Modeling of the Antenna
 - Far-field verification on tester
 - Modified near-field estimates
- ★ Measure good and bad antenna patterns
 - Build a test jig
 - Verify near-field estimates.



**RF RECEIVER AND PROCESSING
CONCEPTS EVALUATION PROGRAM
(RAPCEval)**

R. Elliott
FINAL
05/3/2001

Antenna Elements and NEC Model

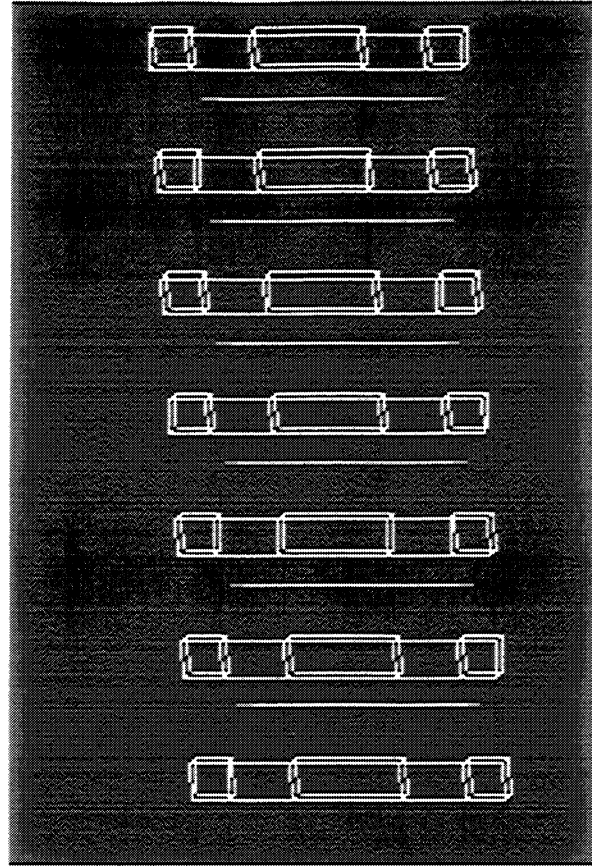
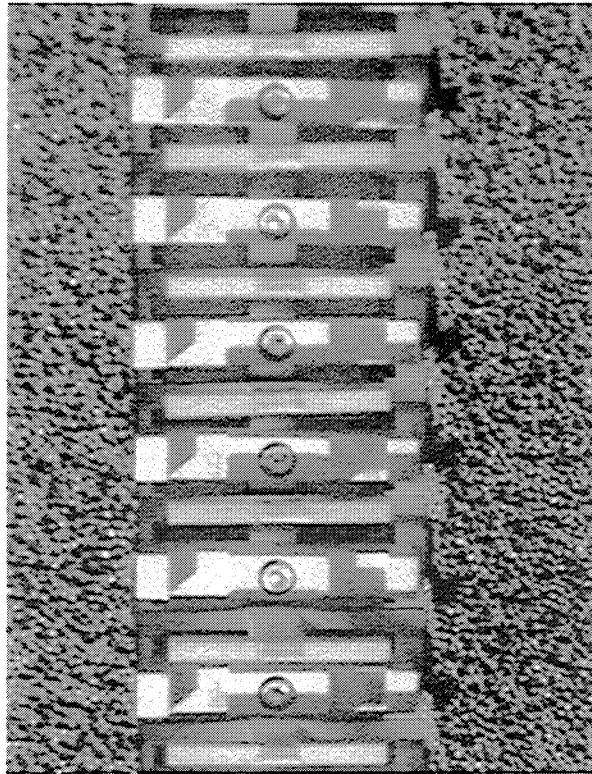



**RF RECEIVER AND PROCESSING
CONCEPTS EVALUATION PROGRAM
(RAPCEval)**

R. Elliott
FINAL
05/3/2001

Analyze Antenna Currents

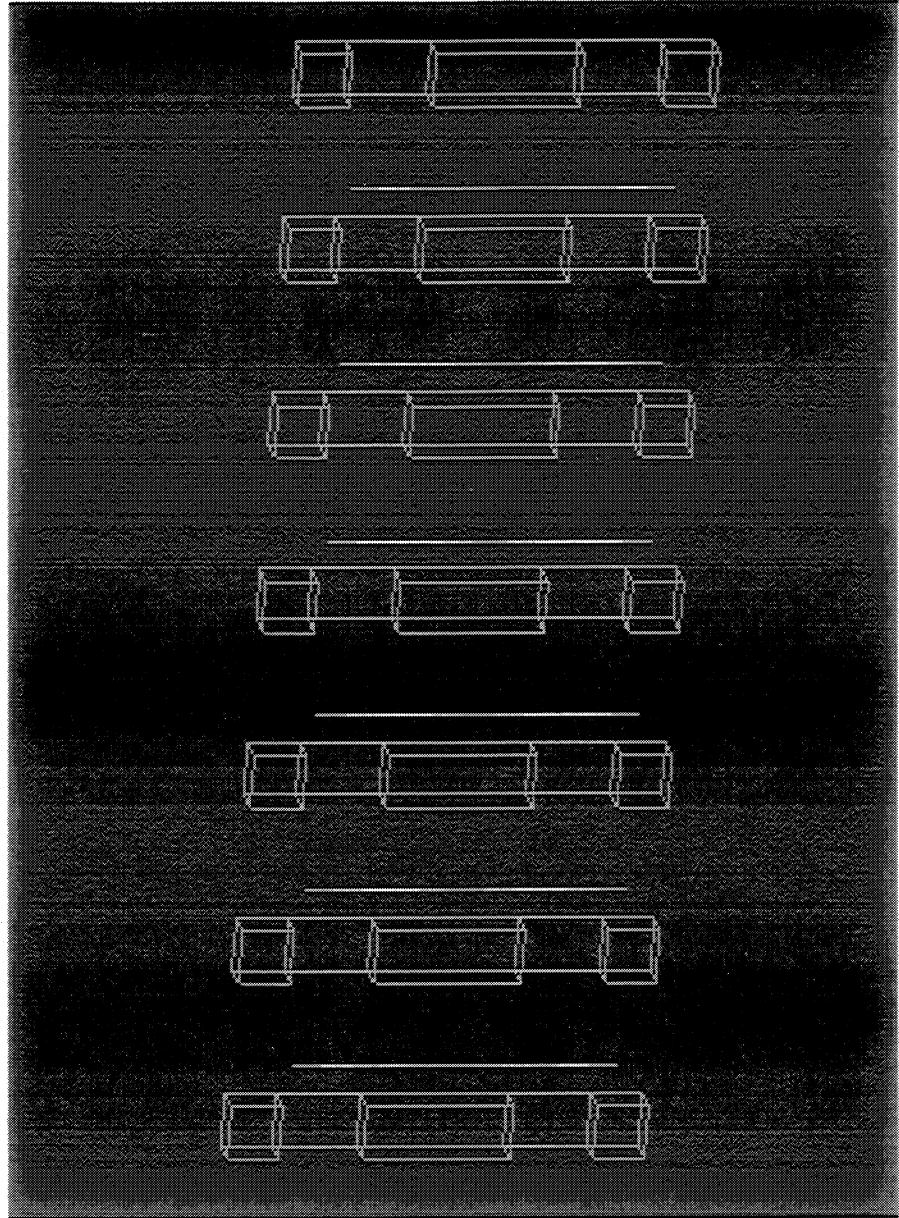



**RF RECEIVER AND PROCESSING
CONCEPTS EVALUATION PROGRAM
(RAPCEval)**

R. Elliott
FINAL
05/3/2001

Final Working NEC Model

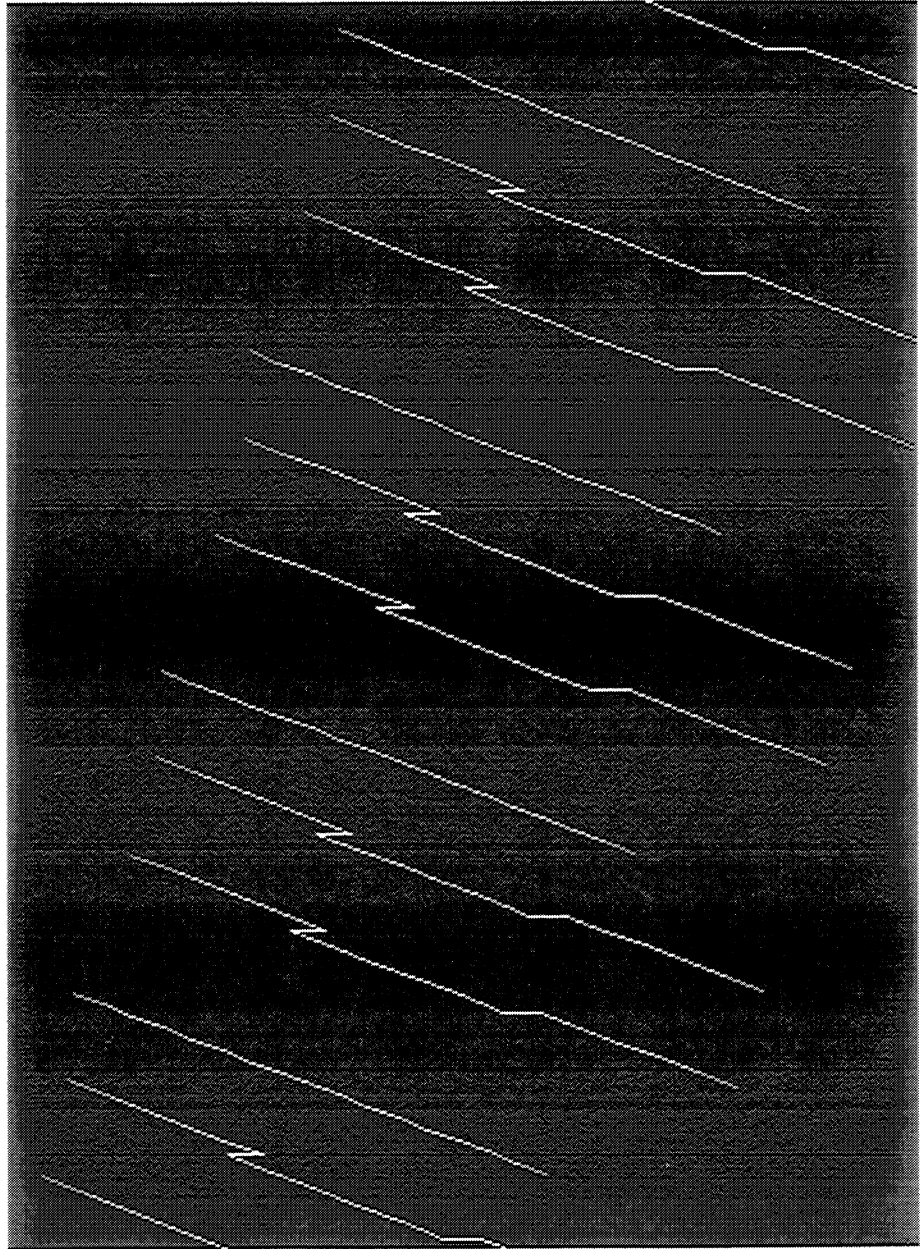

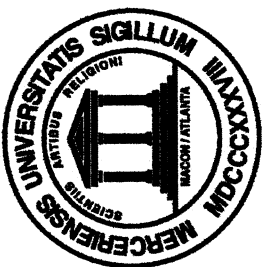

**RF RECEIVER AND PROCESSING
CONCEPTS EVALUATION PROGRAM
(RAPCEval)**

R. Elliott
FINAL
05/3/2001

NEC Antenna Pattern

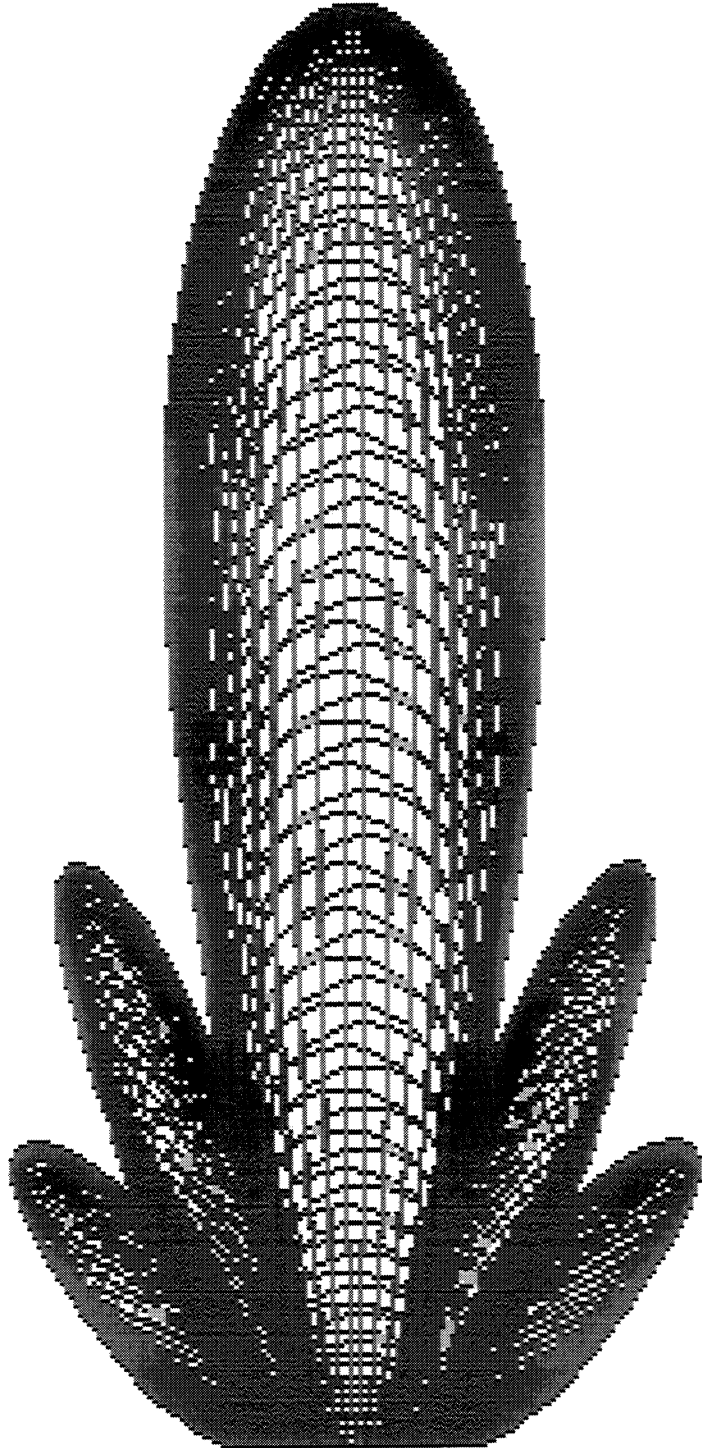



RF RECEIVER AND PROCESSING
CONCEPTS EVALUATION PROGRAM
(RAPCEval)

R. Elliott
FINAL
05/3/2001

A MODIFIED NEAR-FIELD TECHNIQUE FOR SUPPORTING
THE PHASED-ARRAY ANTENNA SYSTEM

FAR-FIELD VERIFICATION RESULTS

- ★ Side lobe level (left only)
 - Tester is -13.35 dB down from peak
 - NEC is -13.38 dB down from peak
- ★ NEC null angle within 0.5° of tester



**RF RECEIVER AND PROCESSING
CONCEPTS EVALUATION PROGRAM
(RAPCEval)**

R. Elliott
FINAL
05/3/2001

Right Lobe Antenna Test Problem

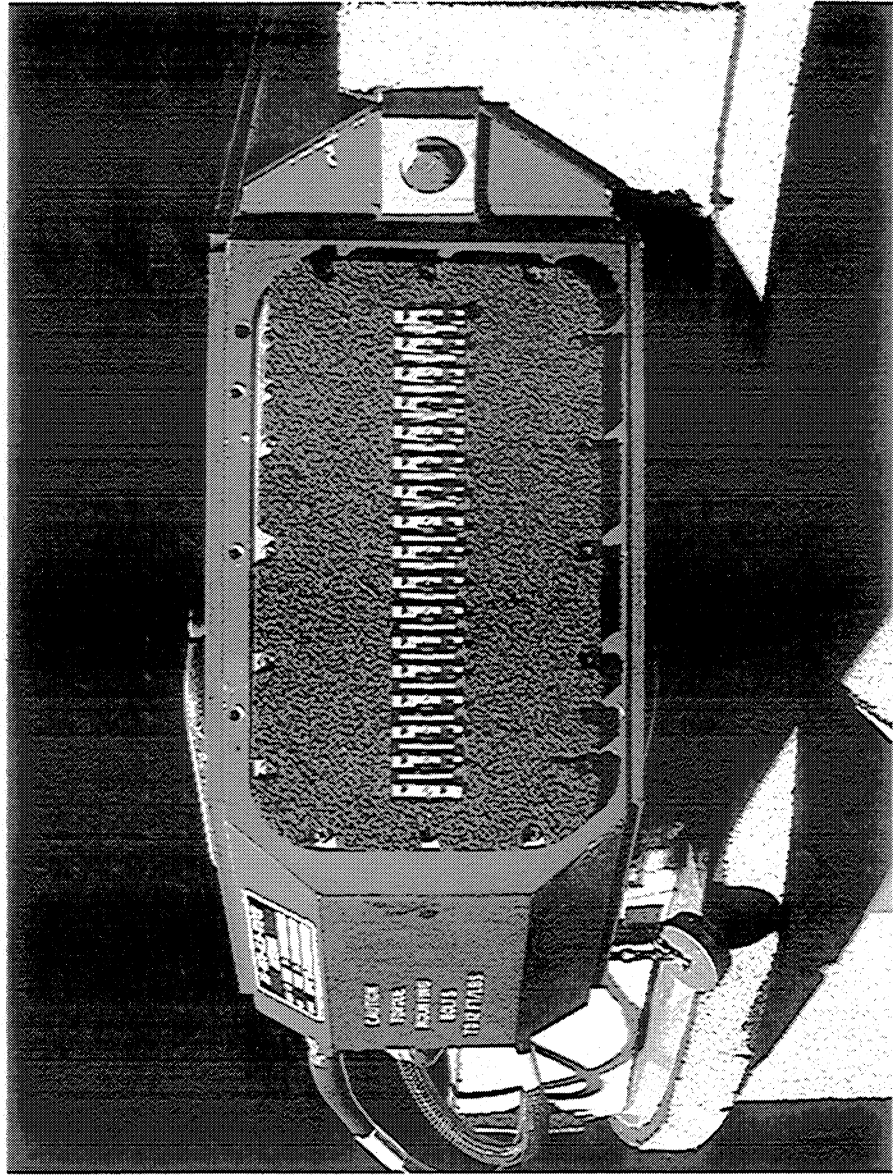



**RF RECEIVER AND PROCESSING
CONCEPTS EVALUATION PROGRAM
(RAPCEval)**

R. Elliott
FINAL
05/3/2001

Relative Power Out of PAAS Elements

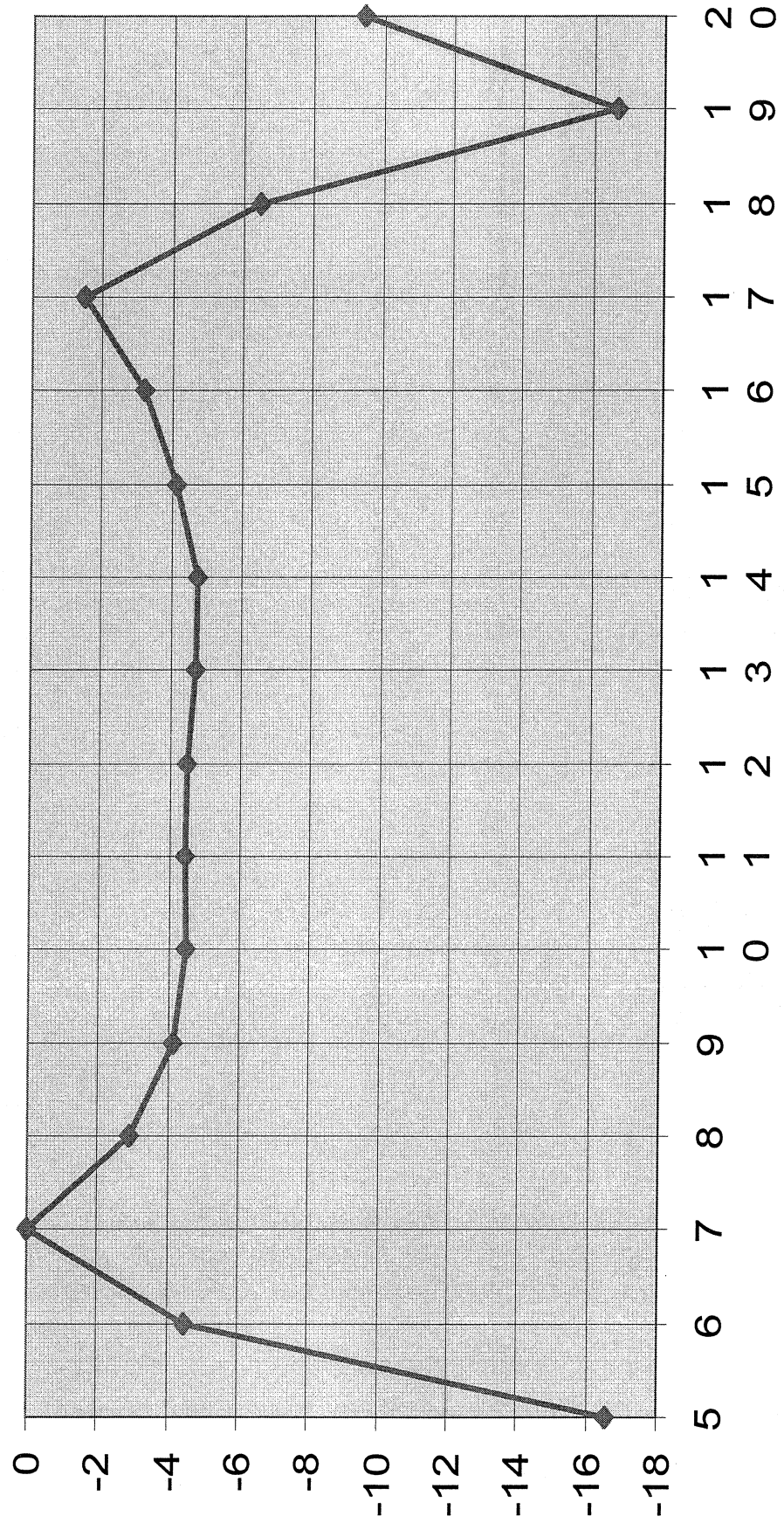



**RF RECEIVER AND PROCESSING
CONCEPTS EVALUATION PROGRAM
(RAPCEval)**

R. Elliott
FINAL
05/3/2001

Antenna Test Setup

2.
5.
8.
11.
14.
17.
20.
23.
26.
29.
32.
35.
38.
41.
44.
47.

+ Boresight

+ Offset



**RF RECEIVER AND PROCESSING
CONCEPTS EVALUATION PROGRAM
(RAPCEval)**

R. Elliott
FINAL
05/3/2001

Near-Field Differences from X=0

X	5.00	6.00	7.00	8.00	9.00	10.00	11.00	12.00	13.00	14.00	15.00	16.00	17.00	18.00	19.00	20.00
0.00	0.0	0.0	0.0	0.0	0.0	0.0	0.0	0.0	0.0	0.0	0.0	0.0	0.0	0.0	0.0	0.0
0.01	-0.4	-0.2	0.7	0.1	0.3	0.1	-0.3	-0.4	0.1	0.5	0.2	-0.1	-1.4	-1.5	4.9	-1.4
0.02	-0.8	-0.3	0.5	0.2	0.5	0.2	-0.2	-0.2	-0.1	0.0	0.0	0.0	-0.6	-0.1	2.4	-1.9
0.03	-0.5	0.0	0.1	-0.1	0.0	0.0	0.0	0.0	0.2	0.5	0.2	-0.2	-0.8	-1.5	2.2	0.4
0.04	0.1	0.6	0.5	0.0	0.0	-0.1	-0.6	-0.6	-0.1	0.3	0.1	0.1	-0.3	-0.1	4.8	-2.0
0.05	-0.1	0.8	0.3	0.5	0.8	0.5	0.1	0.0	0.0	0.2	-0.1	-0.5	-1.9	-1.9	1.5	-1.0
0.06	-1.4	-0.1	1.3	0.4	0.6	0.5	0.4	0.4	0.8	1.1	1.0	1.0	0.7	0.6	3.6	-0.2
0.07	-3.2	-2.4	0.8	-1.3	-1.3	-1.3	-1.7	-1.5	-1.3	-0.9	-1.0	-1.2	-1.7	-1.7	3.6	-2.0
0.08	-5.1	-6.1	-1.9	-4.5	-4.7	-5.1	-5.5	-5.7	-5.5	-5.3	-5.5	-5.5	-6.4	-3.8	-2.4	-14.0
0.09	-7.0	-10.7	-4.7	-8.4	-8.7	-9.5	-9.9	-10.4	-10.1	-10.3	-10.1	-10.3	-10.9	-7.7	4.3	-16.6
0.10	-8.4	-15.1	-7.2	-12.0	-12.5	-13.4	-13.9	-14.5	-14.2	-14.6	-14.5	-14.8	-15.1	-12.8	-5.8	-21.3
0.11	-9.7	-19.0	-9.5	-15.0	-15.7	-16.5	-17.1	-17.6	-17.6	-17.9	-18.3	-18.5	-18.9	-15.5	-7.7	-17.5
0.12	-10.9	-22.1	-11.4	-17.4	-18.2	-18.9	-19.7	-20.1	-20.4	-20.4	-21.4	-21.3	-22.2	-17.0	-9.7	-16.7
0.13	-12.0	-24.7	-13.0	-19.3	-20.3	-20.8	-21.9	-22.0	-22.6	-22.4	-24.0	-23.5	-25.0	-18.4	-11.5	-17.1
0.14	-13.0	-26.9	-14.4	-20.9	-22.1	-22.4	-23.6	-3.6	-24.4	-24.0	-26.0	-25.3	-27.3	-19.7	-13.0	-18.1



RF RECEIVER AND PROCESSING CONCEPTS EVALUATION PROGRAM (RAPCEval)

R. Elliott
FINAL
05/3/2001

Near-Field Differences at $X = 0.05$ m

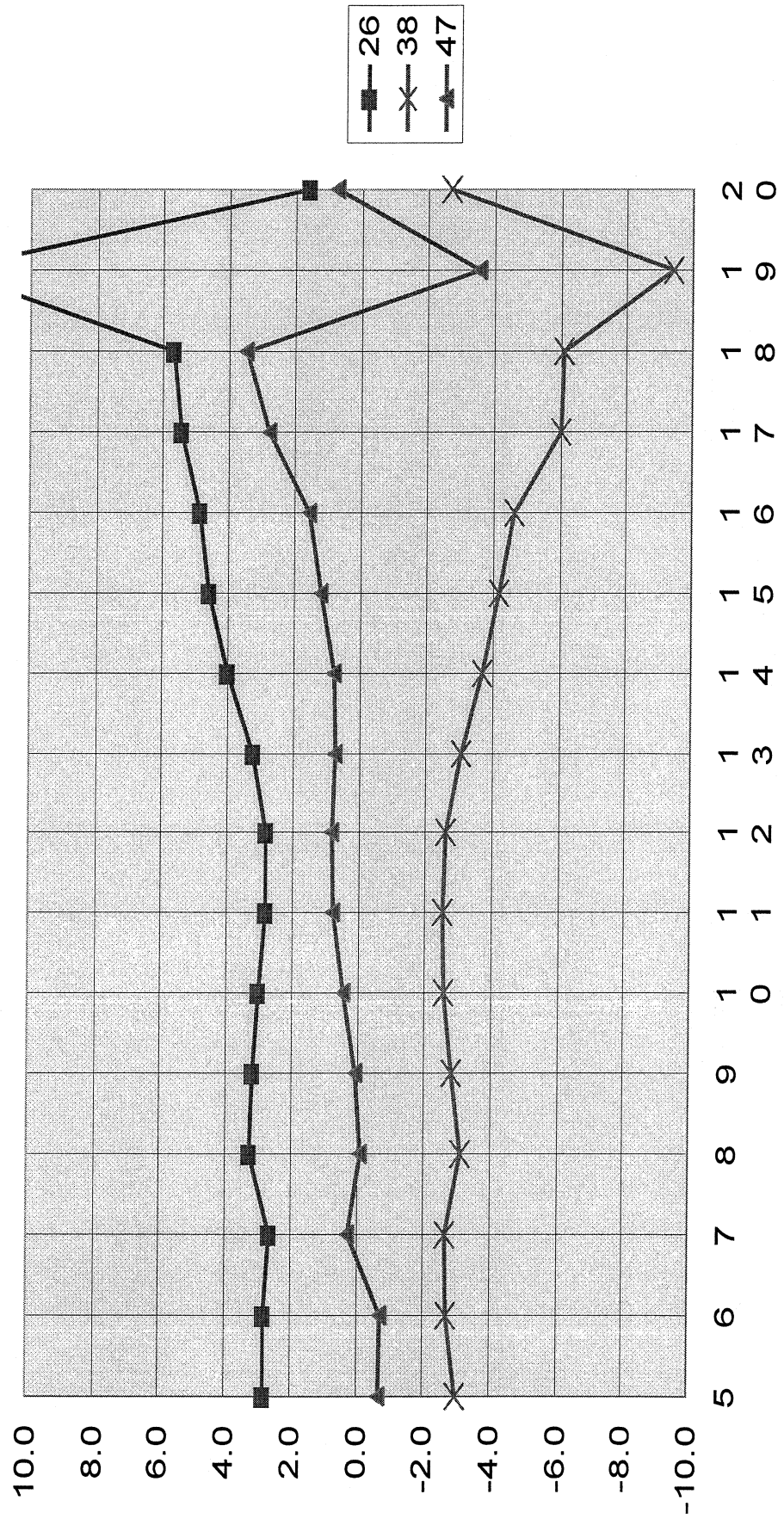



RF RECEIVER AND PROCESSING CONCEPTS EVALUATION PROGRAM (RAPCEval)

R. Elliott
FINAL
05/3/2001

Near-Field Differences at $X = 0.07$ m

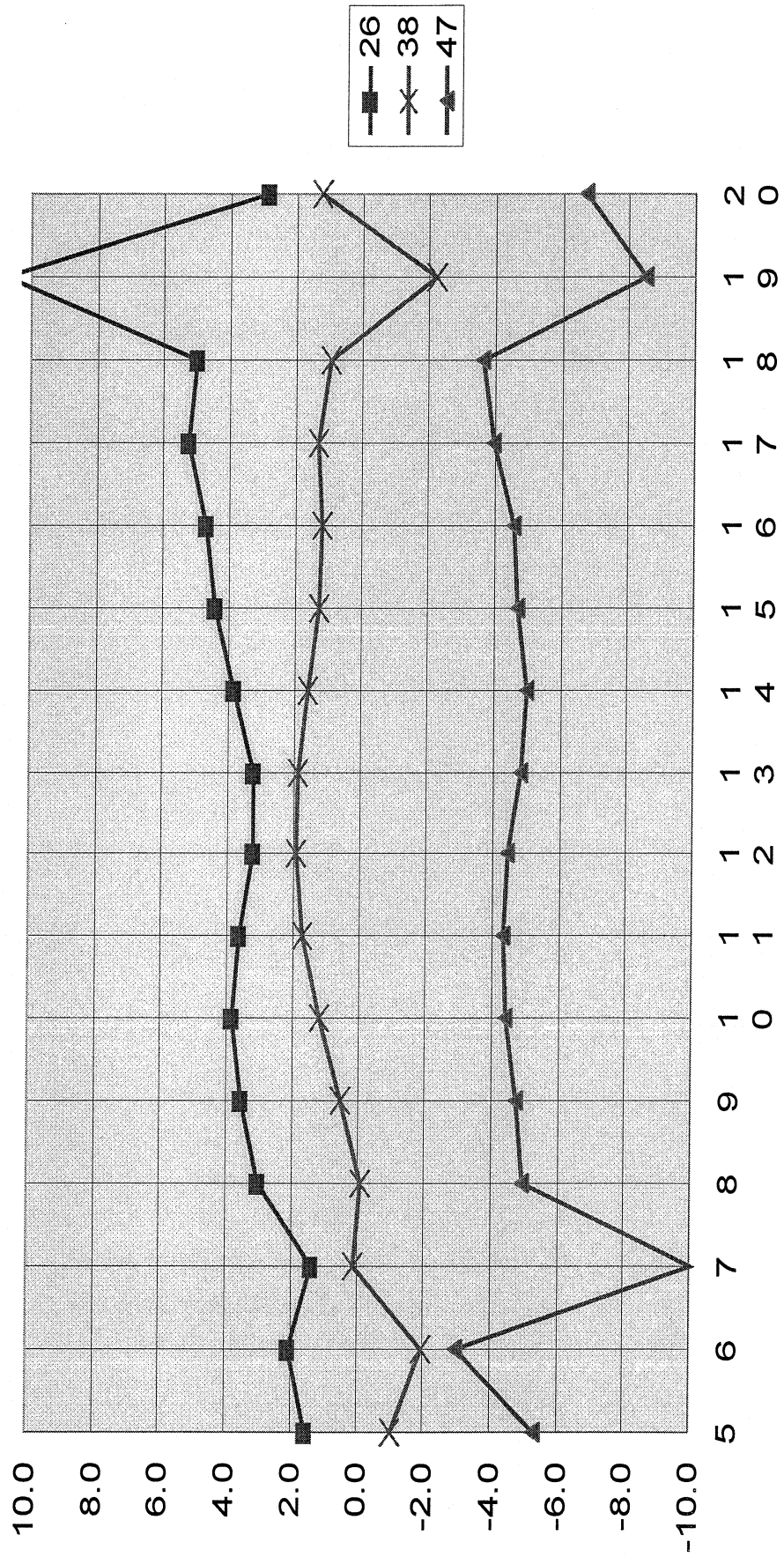



**RF RECEIVER AND PROCESSING
CONCEPTS EVALUATION PROGRAM
(RAPCEval)**

R. Elliott
FINAL
05/3/2001

Near-Field Differences at $X = 0.09$ m

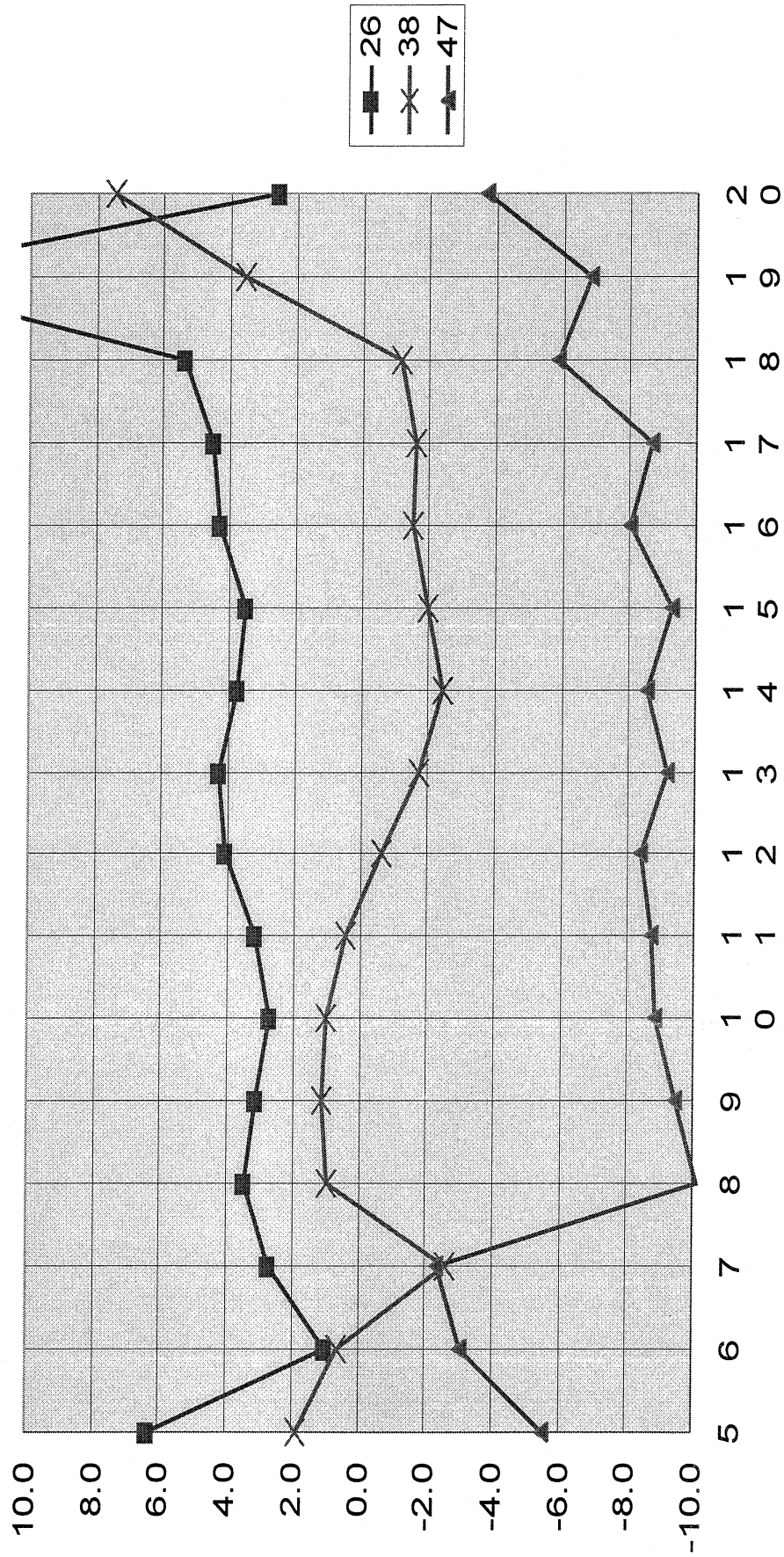



RF RECEIVER AND PROCESSING CONCEPTS EVALUATION PROGRAM (RAPCEval)

R. Elliott
FINAL
05/3/2001

Near-Field Differences at X = 0.11 m

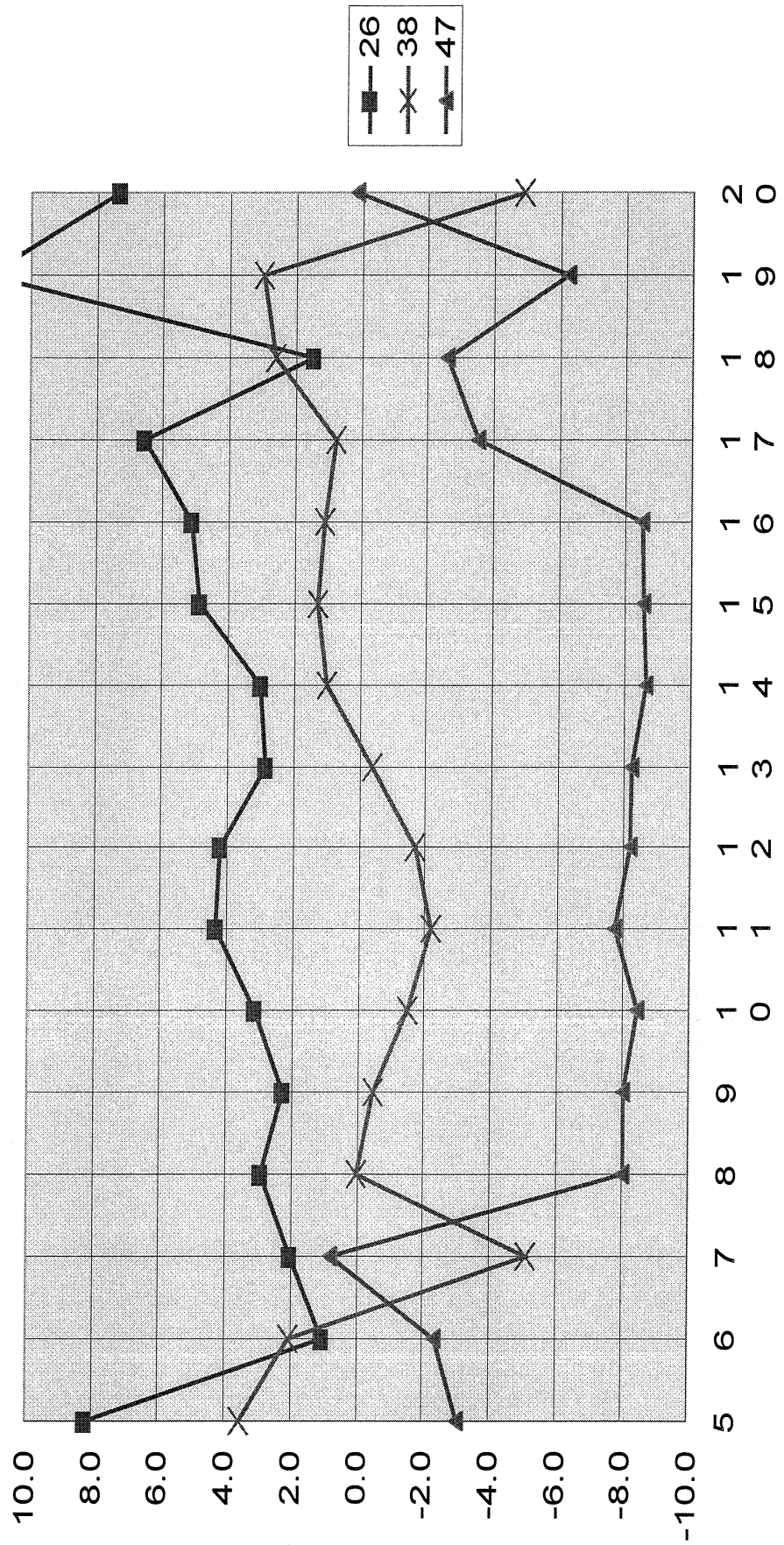



RF RECEIVER AND PROCESSING
CONCEPTS EVALUATION PROGRAM
(RAPCEval)

R. Elliott
FINAL
05/3/2001

Conclusion

- ★ Detection of additional faults is possible using this method.
- ★ Phase measurements are not necessary. The power levels alone will work.
 - Present equipment cannot measure phase.
- ★ More than one probe offset might be needed to detect some element failures.
- ★ More computer power is not needed to compare to element fault signatures.
- ★ Fault signatures are distinctive enough to aid depot to speed troubleshooting.



**RF RECEIVER AND PROCESSING
CONCEPTS EVALUATION PROGRAM
(RAPCEval)**

R. Elliott
FINAL
05/3/2001

Clean Up

- ★ Finish Verifying in the chamber
- ★ Present formal recommendations to equipment specialist
- ★ Finalize thesis



**RF RECEIVER AND PROCESSING
CONCEPTS EVALUATION PROGRAM
(RAPCEval)**

R. Elliott
FINAL
05/3/2001

Future Areas

- ★ Test right side of antenna
- ★ Build dipole calibration antenna
- ★ Build and test model for slot elements of AN/ALQ-182
PAAS
- ★ Build and test models for other general types of
antennas

5.2 Report by Dr. Behnam Kamali

A report generated by Dr. Behnam Kamali, of Mercer University School of Engineering, Electrical Engineering Department, is reproduced here on the next 11 pages.

Transform Domain Communications Systems; Algorithms, Implementation, and Open Areas

Behnam Kamali, Ph.D., P. E.

A Brief Report Submitted to Air Force Research Laboratory at
Wright-Patterson AF Base

March 22, 2001

1. Introduction

The operation of transform domain communications systems (TDCS) hinges on the idea of signal spectral shaping based on collected sample data that characterizes the spectral composition of the surrounding environment. The spectral shaping is primarily carried out in the transform domain. Accordingly, the spectrum of TDCS signal is synthesized to avoid interfering band of frequencies. Major applications, envisioned for TDCS, are combating intentional interference (jamming), and providing low probability of signal interception (LPI).

Traditionally spread spectrum (SS) techniques are applied for suppression of both unintentional and intentional interference for military as well as commercial applications. In some cases the interference immunity that is afforded by SS systems provides a sufficient degree of interference suppression. In other cases where more sophisticated and powerful jamming schemes are involved, SS methods alone may not provide the desired level of interference cancellation [1]. Under these circumstances, one needs to complement SS signaling with other signal processing techniques such as interleaving, diversity, and forward error correction (FEC) [2]. Yet when multiple jamming is encountered, SS techniques fall short of providing sufficient protection for the signal. This deficiency has led to other antijamming techniques such as time domain and frequency domain filtering.

Time domain filtering estimates the jamming signal and removes it from the received signal. The difficulty in implementation of time domain filters arises from the fact that the precise values of amplitude, phase, and frequency of the interfering signal must be estimated. It has been demonstrated that when time domain filters can be designed and implemented, they are very effective against narrowband jamming in which the bandwidth of the interfering signal is no more than 10 percent of that of the system. Time domain filtering, even if it can be properly implemented, fails against other forms of interference and multiple jamming [1].

In *transform domain filtering*, precursor of TDCS, frequency domain processing is employed to implement a notch filter that removes the interfering signals by adjusting the position of notches. However, while eliminating interfering energies, transform domain filters also remove parts of the useful signal, which would degrade the error performance of the system.

Time domain and frequency domain filtering techniques undertake the jamming rejection problem at the receiver side. This can affect the information-bearing signal as well, which leads to signal distortion. Besides, the filtering techniques are effective only against tone and narrowband jammers.

In transform domain communications, the signal is designed at the transmitter such that the jamming frequencies are avoided altogether. In this manner the receiver notch filters excise jamming energies without degrading the information-bearing signal [3].

2. Transform Domain Communications Systems

There are a number of techniques that may be employed to improve the performance of direct sequence spread spectrum (DS-SS) systems against interference and jamming, without requiring additional RF bandwidth for the system. Chief among these techniques is transform domain communication approach. Several transform domains, such as Fourier, discrete cosine, and wavelet have been investigated and tested by various researchers; however, the scope of this report is limited to Fourier transform domain.

Transform domain communications systems distinguish themselves from conventional RF communications systems, primarily, by virtue of the fact that communication signals are synthesized in the frequency domain. The magnitude spectrum of the signal is synthesized in the transform domain by essentially using the same techniques that are employed in transform domain adaptive filters. A second major difference is that TDCS does not employ carrier modulation techniques, although digital data modulates the generated signal. The TDCS is a wideband system and employs pseudorandom codes to generate its noise like signals. However, the purpose of the pseudorandom code is not to spread the spectrum of the signal, as is the case in DS-SS systems, but rather to provide random phase.

One impetus behind Fourier domain popularity for TDCS applications, is the availability of fast and efficient DSP algorithms for computation of direct and inverse Fourier transform [4]. Figure 1 illustrates a general functional block diagram of a Fourier transform domain communication system.

The promise of TDCS is to avoid interference by designing signal waveforms that are essentially orthogonal (or quasi-orthogonal) to all jamming signals in the communication channel. However, it should be noted that a given communication technique, including TDCS, might be quite successful to combat certain type of jamming but ineffective to cope with the others.

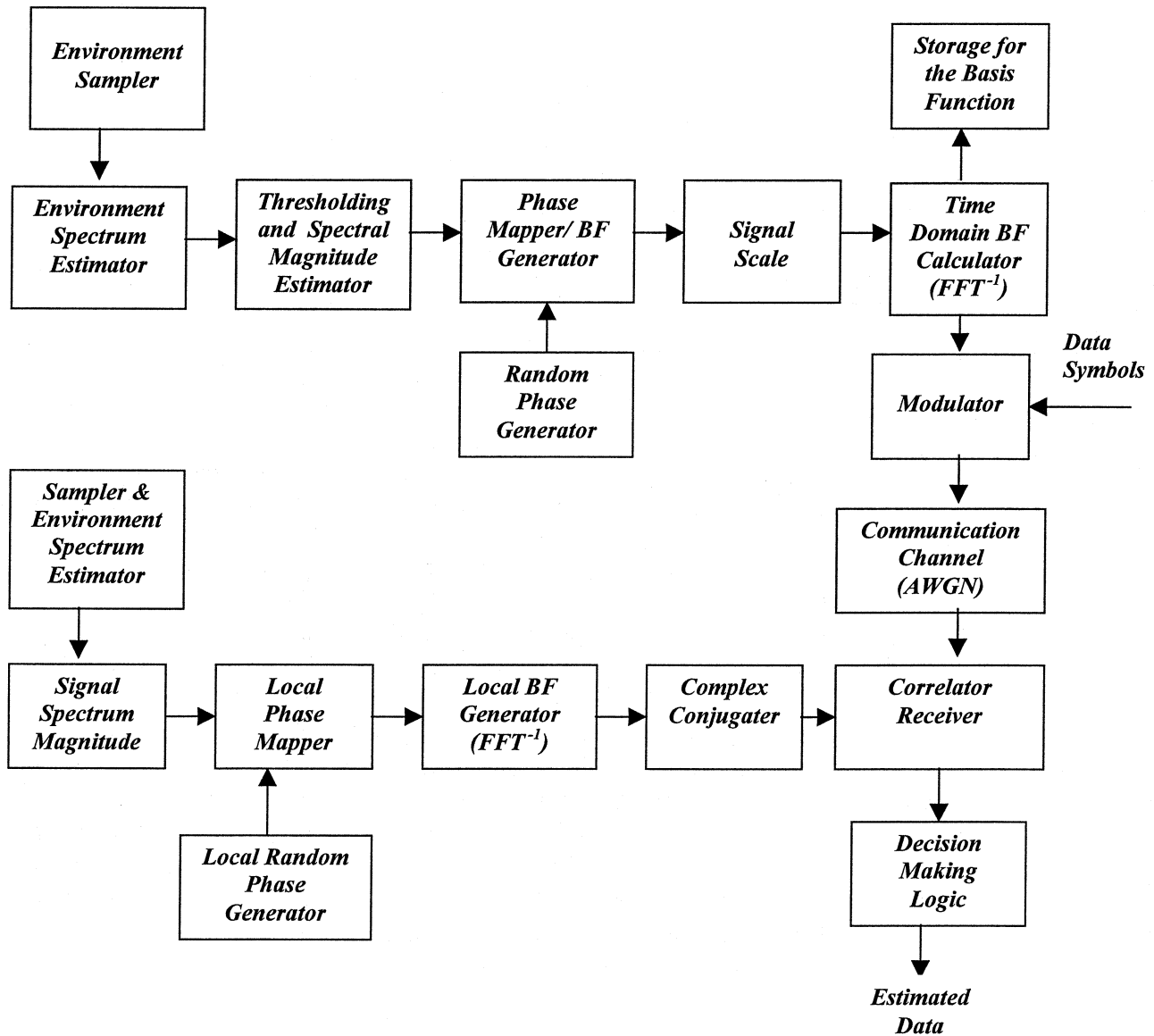

Figure 1: A Functional Block Diagram of a Fourier Transform Domain Communication System; the Transmitter and the Receiver are assumed to observe the same Environmental PSD.

There are three or four jamming techniques in common use. In *barrage noise* or *wideband jamming*, which is the most benign form of jamming threat, the interferer transmits bandlimited white Gaussian noise whose power spectral density covers the entire target system bandwidth. The effect of wideband jamming is simply raising the channel noise floor, and thereby reducing the signal-to-noise ratio of the jammed signal. *Pulse jammer* transmits wideband Gaussian noise much like a barrage noise jammer, but for a short period of time with higher power. In this case a particular bit of data is degraded or unaffected depending on whether the jamming source is “on” or “off” at the time of the bit transmission through the channel. *Partial band* or *narrowband jamming*

refers to the technique in which the jammer concentrates its entire available power in a band that overlaps a small portion of the target system bandwidth. This is perhaps the most commonly applied jamming strategy, for it could be more disruptive than a broadband jammer to a target system, while it is easier to implement. A special case of narrowband jammer is the *single-tone* jammer, which transmits unmodulated carrier signal whose frequency is within the bandwidth of the target signal. *Multiple-tone* jammer uses several tones, which share the total available power. This is a quite effective jamming against frequency hopping (FH) signaling. *Swept-tone* jamming consists of a single-tone jammer whose carrier frequency hops from one value to the other.

Unlike conventional digital communication systems for which symbols are designed and processed in the time domain, TDCS signals are primarily synthesized in the transform domain. At the transmitter a *sampler* (that consists of an antenna, a bandpass filter, and a quantizer) samples the electromagnetic environment over the bandwidth within which the system operates. The digitized samples are fed to a spectrum estimator to determine the band of frequencies that is occupied by interfering signals. The time domain samples are used to estimate the power spectral density (PSD) of the local environment. This is a critical function of TDCS transmitter (and perhaps receiver as well) since the quality of communication is directly dependent upon how accurately the environmental PSD is estimated.

The estimated spectrum is used to separate “quiet” frequency bands from the bands that are occupied by potential interferers. This is accomplished by comparing the magnitude of various parts of the estimated PSD with a selected “threshold” level. The parts, whose magnitude falls below the threshold level, identify the idle frequency bands that are available for signal transmission. The *signal spectral magnitude estimator* then synthesizes the spectrum of the TDCS waveform by including clear frequencies in the signal spectrum and notching out the jammed bands. In this manner the system will have a natural interference and jamming suppression characteristics.

The *random phase generator* produces complex random phase vectors to be point multiplied by the magnitude of the signal spectrum in the *phase mapper* block. The spectrum of the *basis function (BF)* then appears at the output of the phase mapper. The inclusion of complex random phase is required to ensure that the BF has a noiselike shape in the time domain [4]. The resultant spectrum is scaled and inverse Fourier transformed, perhaps using an inverse FFT algorithm, to produce an N-sample time domain version of the BF. This signal is similar to a white noise random process, i.e., the autocorrelation function of this signal is approximately an impulse function. This implies that time cross correlation between the BF and its time-shifted versions is very low, i.e., the BF and its time-shifted versions are nearly orthogonal. It should be noted that as the spectral shape of the surrounding environment varies, the BF is periodically and accordingly changed. Critical to reliable communications via a TDCS is that the receiver know what BF has been used for each transmitted symbol. This process of adapting the BF according to the changes of local electromagnetic activities renders the system to have a bursty mode as opposed to continuous transmission mode.

Two classes of *modulation* schemes have been used in description and operational characterization of transform domain communications systems. In *antipodal modulation*, the basis function and the negative of the BF represent the basic binary symbols. This signaling is similar to BPSK and NRZ baseband modulations, which with coherent detection provides the best error performance among all binary modulation schemes [5]. *Cyclic shift keying* (CSK) is a modulation scheme that uses the BF and its circular shifted versions to represent basic digital symbols. Since these functions are nearly orthogonal, the CSK modulation is approximately an orthogonal signaling method. Although the error performance of orthogonal modulation schemes is inferior to that of antipodal modulation, CSK has an important advantage over antipodal modulation. With CSK it is possible to go beyond binary signaling and obtain higher level of modulation. Thus, one can select M CSK waveforms to carry k bits of data simultaneously. The waveforms are cyclically shifted forms of the basis function. As the number of waveforms, M , is increased the orthogonality of the waveforms is curtailed. This places the final limit on the number of data bits, k , which can be transmitted with each CSK waveform.

A fundamental limitation of TDCS is that both receiver and transmitter must come up with the same power spectral density (PSD) for the environment surrounding the system. There are two possibilities that one might apply to achieve this objective. First, the transmitter provides the receiver with sufficient direct or indirect information related to the spectral shape of the transmitter surrounding environment. Second, the distance between the transmitter and receiver is strictly limited to that of providing the same spectral shape. This implies that spectral estimation algorithms must be the same in the transmitter and the receiver. In Figure 1 it is assumed that the spectrum observed at receiver and at the transmitter have identical shape. Note that the complex conjugation process is not required if the BF is real.

3. Principal Algorithms Required for the Implementation of TDCS

A key algorithm in the operation and implementation of reliable transform domain communication systems is the method of estimation of the local environment PSD. This algorithm directly affects the antijamming properties of the system. It is a well-known result that a spectral estimation technique may be effective in combating certain forms of jamming but inadequate against others [6]. The most straightforward, and perhaps the simplest spectral estimation algorithm results by using the *Periodogram* technique. Periodogram uses the direct Fourier transform of the sample data to estimate the shape of the PSD of a continuous signal. This estimator takes the square of magnitude of the signal Fourier transform, as its estimation of the signal PSD [7]. A problem with this algorithm is that it does not always produce a smooth estimate. In TDCS applications, this complicates the thresholding process that follows the PSD estimation.

A spectral estimation model is said to be an *autoregressive* (AR) model of order p if its estimate may be put into a square magnitude of a rational function of frequency with p poles and no zeros, as given in equation 1.

$$\hat{S}(\omega) = \left| \frac{b_0}{1 + a_1 e^{-j\omega} + a_2 e^{-j2\omega} + \dots + a_p e^{-jp\omega}} \right|^2 \quad (1)$$

This “all pole” model is particularly appropriate for estimation of spectra, which contain sharp peaks but not sharp notches [8].

A spectral estimator is said to have moving average (MA) model of order q , if the estimate can be represented by a square magnitude of a polynomial function of frequency of degree q , as represented in equation 2.

$$\hat{S}(\omega) = \left| b_0 + b_1 e^{-j\omega} + b_2 e^{-j2\omega} + \dots + b_q e^{-jq\omega} \right|^2 \quad (2)$$

This “all zero” estimator is particularly suitable for the estimation of spectra that contain sharp notches but not sharp peaks.

In a number of applications, including transform domain communication system, the underlying power spectral density contains sharp peaks as well as sharp notches. In these cases neither the AR nor the MA model is adequate for spectral estimation. A model that is capable of efficiently estimating the PSD is the autoregressive moving average (ARMA) model. The estimate in this case takes on the form of magnitude square of a rational function of frequency, as provided in equation 3.

$$\hat{S}(\omega) = \left| \frac{b_0 + b_1 e^{-j\omega} + b_2 e^{-j2\omega} + \dots + b_q e^{-jq\omega}}{1 + a_1 e^{-j\omega} + a_2 e^{-j2\omega} + \dots + a_p e^{-jp\omega}} \right|^2 \quad (3)$$

It is noted that AR and MA models are special cases of ARMA model. Although ARMA models is the estimator of choice for almost all applications, owing to simplicity of algorithm implementation, many prefer to apply MA or AR model [8].

Other available methods of spectral estimation include Levin’s maximum likelihood estimation algorithm, Lee’s spectral matching method, and singular value decomposition (SVD) technique.

The functional assignment to various parts of the PDS of the surrounding environment, and therefore the magnitude spectrum of the basis function, has a number of effects on signaling for TDCS. For instance, orthogonality of the BF is affected by the functions that are used to synthesize the magnitude of the PSD of local surroundings [6]. A method that is commonly used is to assign rectangular functions with two levels of unity and zero for occupied and idle frequency bands, respectively. This composition is known as ideal rectangular spectrum. Realization of a PSD containing rectangular parts may not be practical for real applications. Besides, a more gradual transition may prove beneficial in some other respects [6]. Alternative shapes that may be considered include sinc and

raised cosine pulses. A closely related algorithm is the selection of a procedure for the thresholding process.

The phase mapping procedure is another important algorithm affecting the performance of TDCS. It is this process that transforms the wideband signal into a random process that has spectral properties similar to that of a white noise. A pseudorandom noise sequence, generated by a linear feedback shift register (LFSR) circuit, is used to produce random phase vectors. These vectors possess noise like properties, i.e., phase values have a uniform distribution over the range of $[0, \pi)$ [9]. Maximal length codes (*m-sequence*) may be used for this purpose. A LFSR circuit containing n memory cells is capable of generating pseudorandom codes of period $2^n - 1$. From a possible n outputs r outputs are selected for the mapping process. After each mapping, the circuit is shifted s times. The number of phase values, N , required for point-to-point mapping is equal to the length of the BF. Thus, when the mapping is carried out using *m*-sequences, there are four parameters involved in the phase coding process, namely n , N , r , and s [6,9,10].

Like in any digital communication system, the modulation format that is used for TDCS has direct effect on the system error performance. Antipodal modulation is superior to orthogonal signaling in terms of power efficiency, or equivalently system error performance. However, the required bandwidth for orthogonal signaling in a Fourier transform based TDCS is not a function of M . M -ray CSK can be used to improve the spectral efficiency of system; however, as M is increased the orthogonality of the signal set is compromised which degrades the overall performance of the system. This places the final restriction on the number of data bits that can be carried with each waveform.

4. A Summary of Previously Conducted Research at AFIT

The first of the three MS theses on TDCS produced at AFIT is "Design and Simulation of a Transform Domain Communication System," by Radcliffe [6]. He developed a MATLAB-based Monte Carlo simulation model to study the performance of TDCS in various jamming environments. Conventional DS-SS system is selected as the baseline for performance comparison. The model is produced based on four assumptions, namely, the channel is AWGN, multipath propagation does not exist and the propagation delay is known to the system, and receiver and transmitter are synchronized.

Radcliffe shows that under the aforementioned assumptions, TDCS offers a significant performance improvement over DS-SS in a number of jamming scenarios. For the most part, a 10th order autoregressive model is used for spectral estimation, although periodogram is also applied for the spectral estimation when a swept-tone jammer is present. With the AR estimator he finds that a threshold value of 40 percent of the peak of the estimate provides notch width that matches the corresponding jamming band. He studies TDCS performance in the presence of wideband, partial band, and tone jammers. Since the effect of wideband jammers is to raise noise floor of the system, TDCS does not offer performance improvement over DS-SS. He demonstrates that, using BCSK modulation, TDCS can defeat tone and multiple tone jammers. Applying antipodal modulation, he further shows that TDCS is rather effective against partial band jamming.

He includes several jammer bandwidths from 10 percent to 90 percent of the signal bandwidth, and finds that TDCS performs better against the wide partial band jammers [6,11].

Swackhammer, adopting Radcliffe's MATLAB model, studied the possibility and merits of applying TDCS in a multiple access environment (MAE). The channel access technique that is proposed is very similar to that of conventional DS-SS code division multiple access (CDMA). Since TDCS signals undergo a phase coding process, in which the code is generated by a linear feedback shift register circuit, several TDCS signals may be generated using distinct phase codes and transmitted simultaneously through the channel. The BFs are generated in this fashion are "quasi-orthogonal." He demonstrates that the BFs must have low cross-correlation values, otherwise interference and crosstalk degrade the error performance of the multiple access network. One important Swackhammer's finding is that there is a relationship between BFs, cross correlation and their length, N . He shows that as the length of the BFs is increased, the cross correlation between them decreases, and therefore the error performance of the network improves. He finds an estimate for bit error rate of the system based on the mean squared value of the cross correlations, and shows that it closely approximates the MATLAB based simulated bit error performance for MAE [9, 12].

The research conducted by Radcliffe and Swackhammer assume perfect synchronization. Therefore, no issue related to synchronization process, which is perhaps the most complicated part of any digital communications system, was addressed in these works. Roberts, adopting the findings of the previous works, took on the issue of evaluation of various initial synchronization (acquisition) techniques for TDCS and their effects on the system error performance [10].

Roberts used combinations of two synchronization code words (identical symbols, and nonidentical symbols), three different initial acquisition techniques, namely direct time correlation, German's method, and phase correlation technique, and finally two different detection schemes, i.e., threshold and peak detection, in his evaluations. His results demonstrate that under a fixed probability of false alarm (0.01), detection probability of 0.9 is possible at the input SNR of -23 dB when peak detection is used, and at the input SNR of -21 when threshold detection is applied. He also shows that, with threshold detection, the direct time correlation technique offers the best performance when the input SNR is below -12 dB. For input SNR above -12 dB and with threshold detection, he concludes, German's method provides the best performance. It is a well-known result that the length of synchronization codeword has direct effect on detection probability. Roberts determines that for TDCS, doubling the codeword length, decreases the SNR for a given probability of detection by 3 dB.

5. Open Areas and Recommendations for Future Research

5.1 Spectral Estimation

Estimation of the local environment PSD is a key to construction of reliable TDCS. It has been shown that no single algorithm can defeat all forms of jamming. For instance, the AR model works well against barrage and partial band jamming; however, it is ineffective against swept-tone jammers [6]. One estimation model that has not been applied and may provide good interference avoiding properties against all forms of jamming games is the ARMA model. Should the ARMA model fail to provide a universal antijamming capability, then an adaptive technique should be applied. Other methods that are available include SVD and Lavin's ML estimation method.

5.2 Spectral Shaping Functions

The functions that may be used for the composition of the estimation of the local environment PSD, which determines the magnitude spectrum of the BF, include rectangular, sinc, and raised cosine pulses. What are the effects of pulse shape on the overall performance of a TDCS? Is there a single pulse shape that works best against a particular jamming technique? Is there a pulse shape that is optimum against all types of jamming?

5.3 Random Phase Coding

In a number of studies m-sequence has been used to produce random phase vectors. Since phase coding plays an important role in shaping the basis function, it is worthwhile to look into other pseudorandom code generators. Perhaps Gold and Kasami codes are the prime candidates for this trial. How does the code-generating mechanism affect the overall performance of the system? Is there a code that is optimum for this application?

5.4 Modulation Formats

Modulation is a key signal processing in the implementation of TDCS. Unlike conventional digital communication systems, TDSC does not apply carrier modulation. Antipodal and orthogonal signaling have been proposed and studied for data modulation in TDCS. Other possible modulation schemes need be explored for this application. It is recommended that modulation schemes that are a combination of antipodal and orthogonal signaling be examined for TDCS application. For instance, a quaternary modulation scheme that consists of the following four signals may prove beneficial.

$$\begin{aligned} s_1(t) &= x_{bf}(t) & s_2(t) &= -s_1(t) = -x_{bf}(t) \\ s_3(t) &= x_{bf}\left(\left(t - \frac{T}{2}\right)\right)_T & s_4(t) &= -s_3(t) = -x_{bf}\left(\left(t - \frac{T}{2}\right)\right)_T \end{aligned}$$

This signal set is composed of two antipodal waveform sets that are orthogonal to each other. As such this signaling technique is similar to conventional QPSK. It is proposed that the error performance of this modulation scheme be evaluated and compared to that of QCSK. The generalization of this idea might provide an avenue to overcome the limitation placed on M in M-CSK modulation. The generalized signaling scheme may be represented with the functions given below.

$$\begin{aligned}
 s_1(t) &= x_{bf}(t) & s_2(t) &= -s_1(t) \\
 s_3(t) &= x_{bf}\left(\left(t - \frac{T}{M}\right)\right)_T & s_4(t) &= -s_3(t) \\
 s_5(t) &= x_{bf}\left(\left(t - \frac{2T}{M}\right)\right)_T & s_6(t) &= -s_5(t) \\
 &\bullet & & \\
 &\bullet & & \\
 s_{2M-1}(t) &= x_{bf}\left(\left(t - \frac{(M-1)T}{M}\right)\right)_T & s_{2M}(t) &= -s_{2M-1}(t)
 \end{aligned}$$

5.5 TDCS for Multipath Channels

It is apparent that the military applications of TDCS are mostly directed towards systems that are in motion. Commercial applications in mobile communications are also conceivable for TDCS. To start the study of TDCS performance over multipath fading channels, one may consider the following models:

1. Two-Ray Model
2. Flat Fading with Rayleigh Distribution
3. Flat Fading with Ricean Distribution

5.6 Error Control Coding

Channel coding may be added to TDCS signals to improve error performance or power efficiency of the system. It is recommended that the study of application of channel coding to TDCS be broken up to the following scenarios:

1. Single-channel TDCS with a simple BCH code (perhaps a single error correcting Hamming code) using either antipodal or binary CSK modulation.

2. Single-channel TDCS with MCSK modulation and a word-oriented code, perhaps a simple Reed-Solomon code.
3. Study of the potential performance improvement in a multiple access TDCS when channel coding is added to the system.
4. Study of the benefits of channel coding in TDCS mobile communications systems.

6. References

- [1] L. B. Milstein, "Interference Rejection Techniques in Spread Spectrum Communications," Proceedings of the IEEE, pp. 657-671, June 1988.
- [2] R. L. Peterson, et al., "Introduction to Spread Spectrum Communications," Prentice Hall, 1995.
- [3] C. F. Andren, et al., "Low Probability of Intercept Communications Systems," Harris Corporation, U.S. Patent 5 029 184, 1991.
- [4] J. P. Stephens, et al., "Interference Avoiding Transform Domain Based Communication Systems," unpublished article, Air Force Research Laboratory, Wright-Patterson AFB.
- [5] B. Sklar, "Digital Communications; Fundamental and Applications," second edition, Prentice Hall, 2001.
- [6] R. A. Radcliffe, "Design and Simulation of a Transform Domain Communication System," MS thesis AFIT/GE/ENG/96D-16, Airforce Institute of Technology Wright-Patterson AFB, Dayton, OH, 1996.
- [7] A. Schuster, "On the Investigation of Hidden Periodicities with Applications to a Supposed 26 day period of Meteorological Phenomena," Terrestrial Magnetism, vol. 3, pp. 1341, March 1898.
- [8] J. A. Cadzow, "Spectral Estimation: an Overdetermined Rational Model Equation Approach," Proceedings of the IEEE, Vol. 70, No. 9, September 1982.
- [9] P. J. Swackhammer, "Design and Simulation of a Multiple Access Transform Domain Communication System," MS thesis AFIT/GE/ENG/99M-28, Airforce Institute of Technology Wright-Patterson AFB, Dayton, OH, 1999.
- [10] M. L. Roberts, "Synchronization of a Transform Domain Communication System," MS thesis AFIT/GE/ENG/00M-15, Airforce Institute of Technology Wright-Patterson AFB, Dayton, OH, 2000.
- [11] R. A. Radcliffe and G. C. Gerace, "Design and Simulation of a Transform Domain Communication System," MILCOM'97, October 1997.
- [12] P. J. Swackhammer, et al., "Performance Simulation of a Transform Domain Communications System for Multiple Access Applications," MILCOM'99, November 1999.

6. Conclusions and Plans for Future Activity

The RAPCEval program participants have agreed on the success of this program and the quality of the results that have been produced to date. A very satisfying feature of the work has been the stimulation of cooperation among various engineering communities and their fruitful interaction. Students, university faculty, and government and private sector engineers have united in the common attack on a number of priority Air Force EW concerns. The students' masters' degree research has focused on topics that have immediate impact on the transitioning of new and improved software and hardware technologies into fielded systems.

Fifteen master's degrees have been awarded at the time of this report. The title of each report is listed in Table 2 together with availability information.

Table 2. Masters Degrees Awarded and Related Reports

<i>#</i>	<i>Author</i>	<i>Report Title</i>	<i>Security</i>	<i>Availability</i>
1	Mark Astin	"Parallelization of the RAD Filter"	Classified	Obtain from AFRL/SNRP – Document AFRL-SN-WP-TR-1998-1088
2	Henderson Benjamin	"Neural Network System That Selects Reed-Solomon Codes for a Specific Application"	Unclassified	Obtain from AFRL/SNRP: Document AFRL-SN-TR-1999-1115, Section 5.4
3	Steve Boswell	"Application of a Neural Network with a Fuzzy Logic Controller to Identify Target Signals and Reduce False Alarms"	Unclassified	Submitted Spring 2001 to AFRL; printing in process
4	Peter Bryant	"Rotational Doppler Technique for Geolocation"	Classified	Patent Pending by Mercer University – distribution to follow issue of patent
5	Ron Brinkley	"Burst Error Correction with Reed-Solomon Codes"	Unclassified	Obtain from AFRL/SNRP: #AFRL-SN-TR-1999-1115, Section 5.4
6	Mark Campbell	"Auto-Regressive Spectral Analysis - EW Applications"	Unclassified	Obtain from AFRL/SNRP: #WL-TR-94-1057, Appendix E
7	Randy Ford	"Comparison of Differential Evolution to the Simplex Method in Optimization during Passive Emitter Location"	Unclassified	Obtain from AFRL/SNRP: Document AFRL-SN-WP-TR-2000-1085, Section 5.5

Table 2. Masters Degrees Awarded and Related Reports (Concluded)

#	Author	Report Title	Security	Availability
8	Claus Franzkowiak	“Four-Pulse RAD Filter Extension”	Classified	Obtain from AFRL/SNRP – Document AFRL-SN-WP-TR-1998-1087
9	Neal Garner	“Error Correction and Prediction for Improved Communication of Time and Time Measurements”	Unclassified	Obtain from AFRL/SNRP: Document WL-TR-96-1161, Appendix D
10	Joseph Kelley	“A Parameter Determination Alternative for RAD Analysis”	Classified	Obtain from AFRL/SNRP, WPAFB, Document WL-TR-95-1005
11	Joseph Kelley	“Multi-Group Simultaneous RAD Parameter Selection”	Classified	Obtain from AFRL/SNRP, WPAFB, Document WL-TR-97-1094
12	Max Roesel	“Agile RF/PRI Radar Analysis via RAD”	Classified	Obtain from AFRL/SNRP, WPAFB, Document WL-TR-95-1020
13	Dave Schuler	“Comparison of Algorithms for Geolocation of Radar Signals”	Unclassified	Call MERC for access – requires establishment of “need-to-know” status
14	Tracy Tillman	“Hardware Implementation for Advance Pulse Processing Algorithm”	Classified	Obtain from AFRL/SNRP, WPAFB, Document AFRL-SN-WP-TR-2000-1007
15	Kirk Wright	“Object-Oriented Modeling of the AN/ALQ-172”	Classified	Obtain from AFRL/SNRP - Document AFRL-SN-WP-TR-1998-1086

LIST OF ABBREVIATIONS AND ACRONYMS

AAA – Anti-Aircraft Artillery
AAM – Anti-Aircraft Missile
A/D – Analog-to-Digital
AFIT – Air Force Institute of Technology
AFRL – Air Force Research Laboratory
AFRL/SNR – Air Force Research Laboratory/Sensors Division
AR – Autoregressive
ARMA – Autoregressive moving average
ASIC – Application Specific Integrated Circuit
ATCRBS – Air Traffic Control Radar Beacon System
AWGN – Additive White Gaussian Noise
BCH – Bose Chaudhuri Hocquenghem
BER – Burst Error Rate
BF – Basis function
BPSK – Binary Phase Shift Keying
BSEE – Bachelor of Science and Electrical Engineering
BW - Bandwidth
CDMA – Code division multiple access
CSK – Cyclic shift keying
DSP – Digital Signal Processor
DS-SS – Direct sequence spread spectrum
ECM – Electronic Countermeasures
ELINT – Electronic Intelligence
EO – Electro-Optical
EW – Electronic Warfare
EWTA – Electronic Warfare Techniques Analysis (contractual vehicle)
FEC – Forward Error Correction
FFT – Fast Fourier transform
FH – Frequency Hopping

FPGA – Field Programmable Gate Array
GPS – Global Positioning Satellite
IEEE – Institute of Electrical and Electronics Engineers
IFF – Information Friend or Foe
IR – Infrared
LFSR – Linear feedback shift register
LOS – Line of Sight
LPI – Low probability of interception
M-CSK – Mary Cyclic Shift Keying
MERC - Mercer Engineering Research Center
MA – Moving average
ML – Maximum Likelihood
MSEE – Master’s of Science and Electrical Engineering
MTL – Minimum Triggering Level
NEC – Numerical Electromagnetic Code
NRZ – Non-Return to Zero
NTIS – National Technical Information Service
OOK – On Off Keying
PAAS – Phased Array Antenna System
PDS – Power Spectral Density
PPM – Pulse Position Modulation
PRSCComm – Program Research Standards Committee
PSD – Power spectral density
QCSK – Quadrature Cyclic Shift Keying
QPSK – Quadrature Phase Shift Keying
RAPCEval – Receiver and Processing Concepts Evaluation Program
RAD – Random Agile Deinterleave
RCS – Radar Cross Section
RF – Radio Frequency
RS – Reed-Solomon
SAM – Surface-to-Air Missile

SAR – Segmentation and Reassembly

SIGINT – Signal Intelligence

SNR – Signal-to-noise ratio

SS – Spread Spectrum

SVD – Singular value decomposition

TDCS – Transform domain communication systems

UV - Ultraviolet

WPAFB – Wright-Patterson Air Force Base

WR-ALC - Warner Robins Air Logistics Center

