



UNITED STATES AIR FORCE RESEARCH LABORATORY

MAXPAC Test Program Final Presentation

Joseph Morris

Aerojet
Propulsion Division
P.O. Box 13222
Sacramento CA 95813-6000

December 1996

Final Report for the Period July 1996 to December 1996

20011002 057

Approved for public release; distribution is unlimited.

Human Effectiveness Directorate
Biodynamics and Protection Division
Biodynamics and Acceleration Branch
2800 Q Street BLDG 824 RM 206
Wright-Patterson AFB OH 45433-7947

NOTICES

When US Government drawings, specifications of other data are used for any purpose other than a definitely related Government procurement operation, the Government thereby incurs no responsibility nor any obligation whatsoever, and the fact that the Government may have formulated, furnished, or in any way supplied the said drawings, specifications or other data, is not to be regarded by implication or otherwise, as in any manner licensing the holder or any other person or corporation, or conveying any rights or permission to manufacture, use, or sell any patented invention that may in any way be related thereto.

Please do not request copies of this report from the Air Force Research Laboratory. Additional copies may be purchased from:

National Technical Information Services
5285 Port Royal Road
Springfield, Virginia 22161

Federal Government agencies registered with the Defense Technical Information Center should direct requests for copies of this report to:

Defense Technical Information Center
8725 John J. Kingman Rd STE 0944
Ft. Belvoir, VA 22060-6218

TECHNICAL REVIEW AND APPROVAL

AFRL-HE-WP-SR-2001- 0006

This report has been reviewed by the Office of Public Affairs (PA) and is releasable to the National Technical Information Service (NTIS). At NTIS, it will be available to the general public, including foreign nations.

This technical report has been reviewed and is approved for publication.

FOR THE DIRECTOR

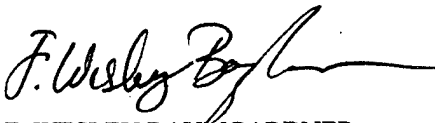

F. WESLEY BAUMGARDNER
Acting Chief, Biodynamics and Protection Division
Human Effectiveness Directorate
Air Force Research Laboratory

REPORT DOCUMENTATION PAGE

Form Approved
OMB No. 0704-0188

Public reporting burden for this collection of information is estimated to average 1 hour per response, including the time for reviewing instructions, searching existing data sources, gathering and maintaining the data needed and completing and reviewing the collection of information. Send comments regarding this burden estimate or any other aspect of this collection of information, including suggestions for reducing this burden, to Washington Headquarters Services, Directorate for Information Operations and Reports, 1215 Jefferson Davis Highway, Suite 1204, Arlington, VA 22202-4302, and to the Office of Management and Budget, Paperwork Reduction Project (0704-0 188), Washington, DC 20503

| | | | |
|--|---|--|---|
| 1. AGENCY USE ONLY (Leave Blank) | | 2. REPORT DATE December 1996 | 3. REPORT TYPE AND DATES COVERED Final - July to December 1996 |
| 4. TITLE AND SUBTITLE MAXPAC Test Program Final Presentation | | 5. FUNDING NUMBERS Contract: F41624-95-C-6014 PE: 63231F PR: 2830 TA: 283068 WU: 28306820 | |
| 6. AUTHOR(S) Joseph Morris | | 8. PERFORMING ORGANIZATION REPORT NUMBER | |
| 7. PERFORMING ORGANIZATION NAME(S) AND ADDRESS(ES) Veridian Engineering, Inc. Human Effectiveness Group 5200 Springfield St., Suite 200 Dayton OH 45431-1285 | | Aerojet Propulsion Division P.O. Box 13222 Sacramento CA 95813-6000 | |
| 9. SPONSORING/MONITORING AGENCY NAME(S) AND ADDRESS(ES) Human Effectiveness Directorate Biodynamics and Protection Division Biodynamics and Acceleration Branch 2800 Q ST BLDG 824 RM 206 Wright-Patterson AFB OH 45433-7947 | | 10. SPONSORING/MONITORING AGENCY REPORT NUMBER AFRL-HE-WP-SR-2001-0006 | |
| 11. SUPPLEMENTARY NOTES | | | |
| 12a. DISTRIBUTION/AVAILABILITY STATEMENT Approved for public release; distribution is unlimited. | | 12b. DISTRIBUTION CODE | |
| 13. ABSTRACT (Maximum 200 words) This report summarizes the results of a United States Air Force funded effort to demonstrate the Multi-Axis Pintle Attitude Control (MAXPAC) system. The MAXPAC system is a spin-off of the Fourth Generation Escape Systems Technology Demonstration Program. MAXPAC uses four discrete, pintle-controlled rocket nozzles to provide variable thrust in three axes. The intent is to provide an under-seat retrofit for the Advanced Concept Ejection Seat (ACES) II replacing the current pitch stabilization rocket with the three-axis stabilization MAXPAC. | | | |
| 14. SUBJECT TERMS Escape system, pintle-control, stabilization | | 15. NUMBER OF PAGES 57 | |
| | | 16. PRICE CODE | |
| 17. SECURITY CLASSIFICATION OF REPORT Unclassified | 18. SECURITY CLASSIFICATION OF THIS PAGE Unclassified | 19. SECURITY CLASSIFICATION OF ABSTRACT Unclassified | 20. LIMITATION OF ABSTRACT UNLIMITED |

This page intentionally left blank.

PREFACE

This report was prepared under contract F41624-95-C-6014, Task 62, Engineering Support of Biodynamics Research – Crew Escape Technologies (CREST) Demonstration Support. The Prime Contractor for this effort was Veridian Engineering, Inc., Dayton, OH and the major subcontractor was Aerojet – Propulsion Division of Sacramento CA.

This Final Report summarizes the results of a United States Air Force funded effort during the period July through December 1996 to demonstrate the Multi-Axis Pintle Attitude Control (MAXPAC) system. The MAXPAC system is a spin-off of the Fourth Generation Escape System Technology Demonstration program. The intent of the program was to provide an under-seat retrofit for the Advanced Concept Ejection Seat (ACES) II replacing the current pitch stabilization rocket with the three-axis stabilization MAXPAC.

THIS PAGE INTENTIONALLY LEFT BLANK

Table of Contents

| | |
|--|----|
| AGENDA..... | 1 |
| MAXPAC OVERVIEW..... | 2 |
| MAXPAC TEST ARTICLE DESIGN REVIEW..... | 4 |
| MAXPAC TEST DATA REVIEW AND GROUND TEST GROUNDING ISSUES.... | 21 |
| CONCLUSIONS AND RECOMMENDATIONS..... | 53 |

This page intentionally left blank.

'96 MAXPAC MOTOR TEST PROGRAM FINAL PRESENTATION



- **AGENDA**
 - ✦ **MAXPAC OVERVIEW**
 - ✦ **PROGRAM OBJECTIVES AND STATUS**
 - ✦ **REVIEW OF TEST ARTICLE DESIGN**
 - ✦ **KISTLER LOAD TABLE DESCRIPTION**
 - ✦ **PROOF TEST RESULTS**
 - ✦ **TEST DATA REVIEW AND GROUND TEST GROUNDING ISSUES**
 - ✦ **CONCLUSIONS & RECOMMENDATIONS**

GENCORP
AEROJET



MAXPAC OVERVIEW

JOE MORRIS

**MAXPAC MOTOR TEST
PROGRAM OBJECTIVES**



| OBJECTIVE | STATUS |
|---|----------|
| DESIGN & ANALYSIS | CMPLT |
| MOTOR ASSEMBLY AND BENCH TESTING | CMPLT |
| TEST PLANS | CMPLT |
| GROUND STATIC MOTOR TESTS | CMPLT |
| REPORTING: MONTHLY TECHNICAL & BUDGET, MOTOR TEST QUICKLOOK | CMPLT |
| MEETINGS: KICK-OFF, TRR, AND FINAL PRESENTATION | 66% CMPT |



GENCORP
AEROJET

MAXPAC TEST ARTICLE DESIGN REVIEW

BILL BARNETTE

HEAVYWEIGHT MOTOR CONFIGURATION

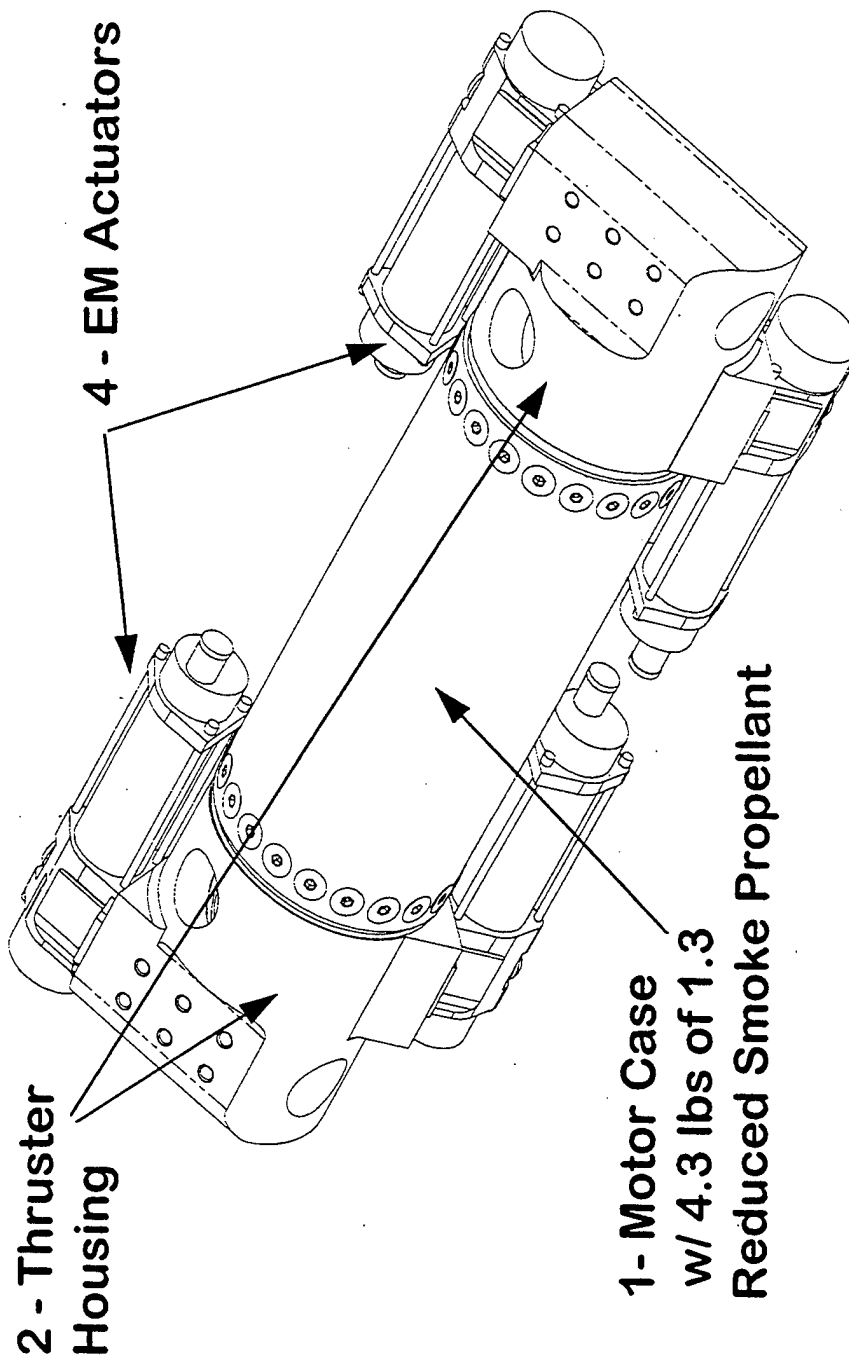

GENCORP
AEROJET

MAXPAC PINTLE MODULE ASSEMBLY



PRECISIONS, CONCEPTIONS, FABRICATIONS, REVISIONS, ET, 1977-1980, GENCORP

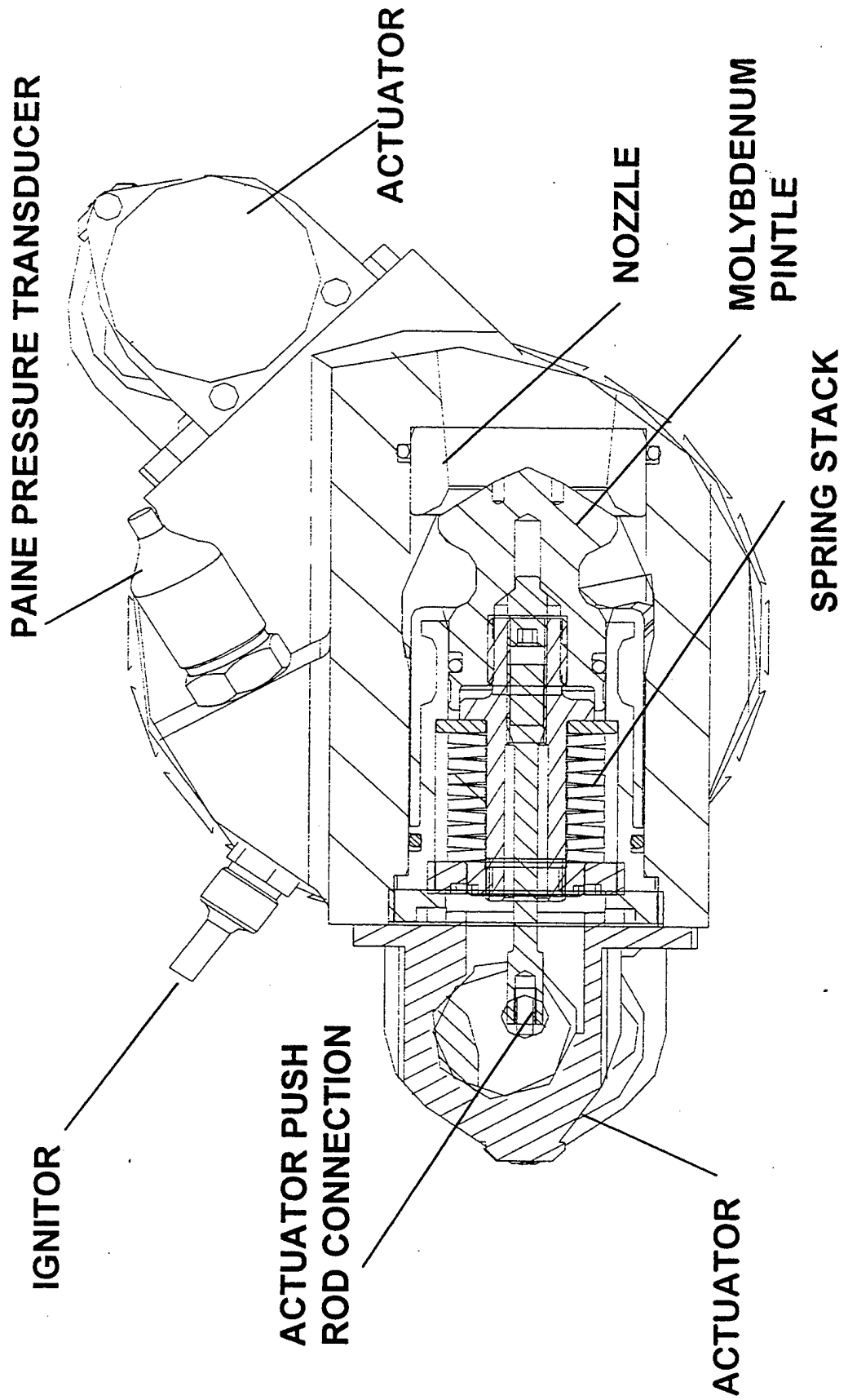

MAXPAC PINTLE MODULE

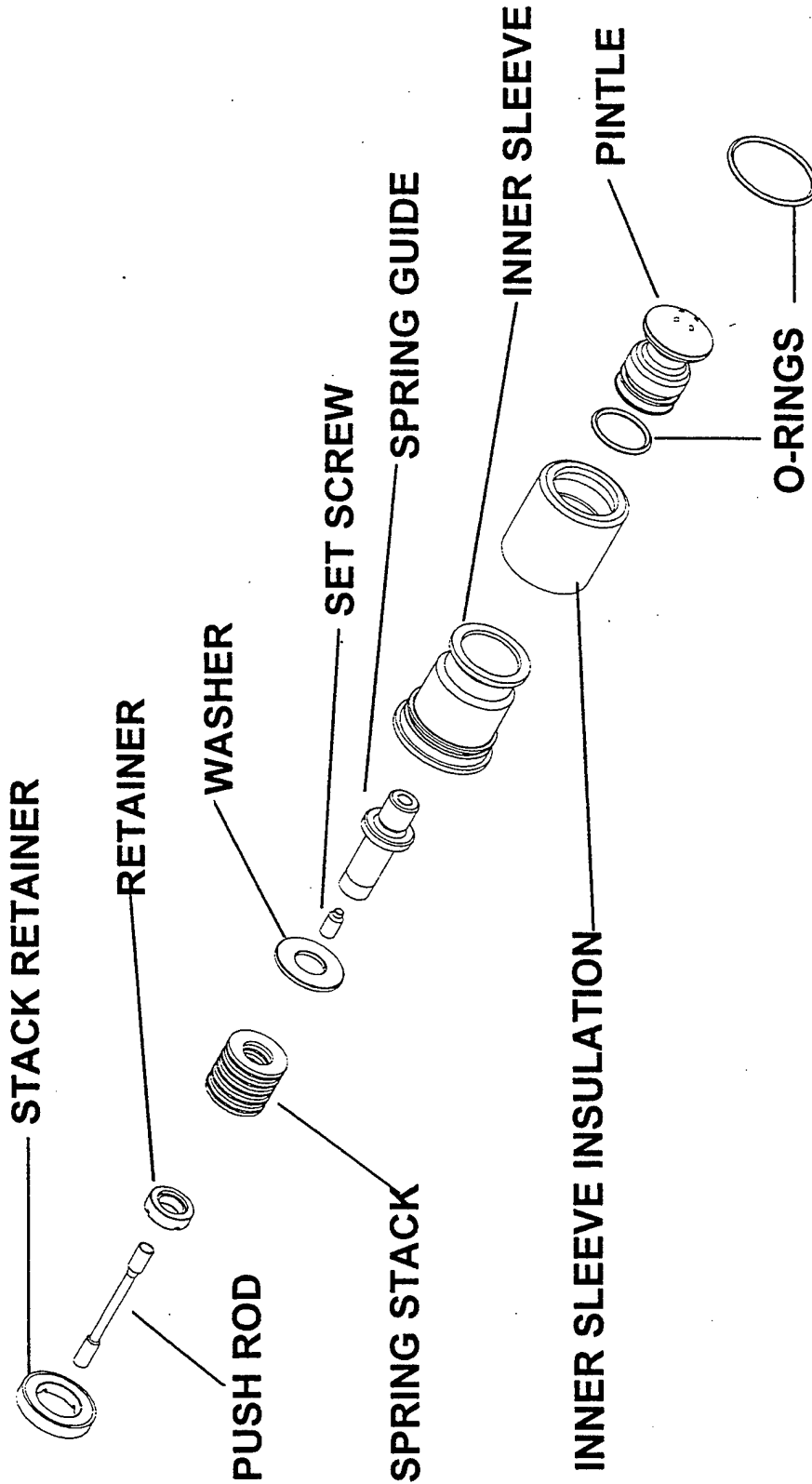

MAXPAC IGNITER

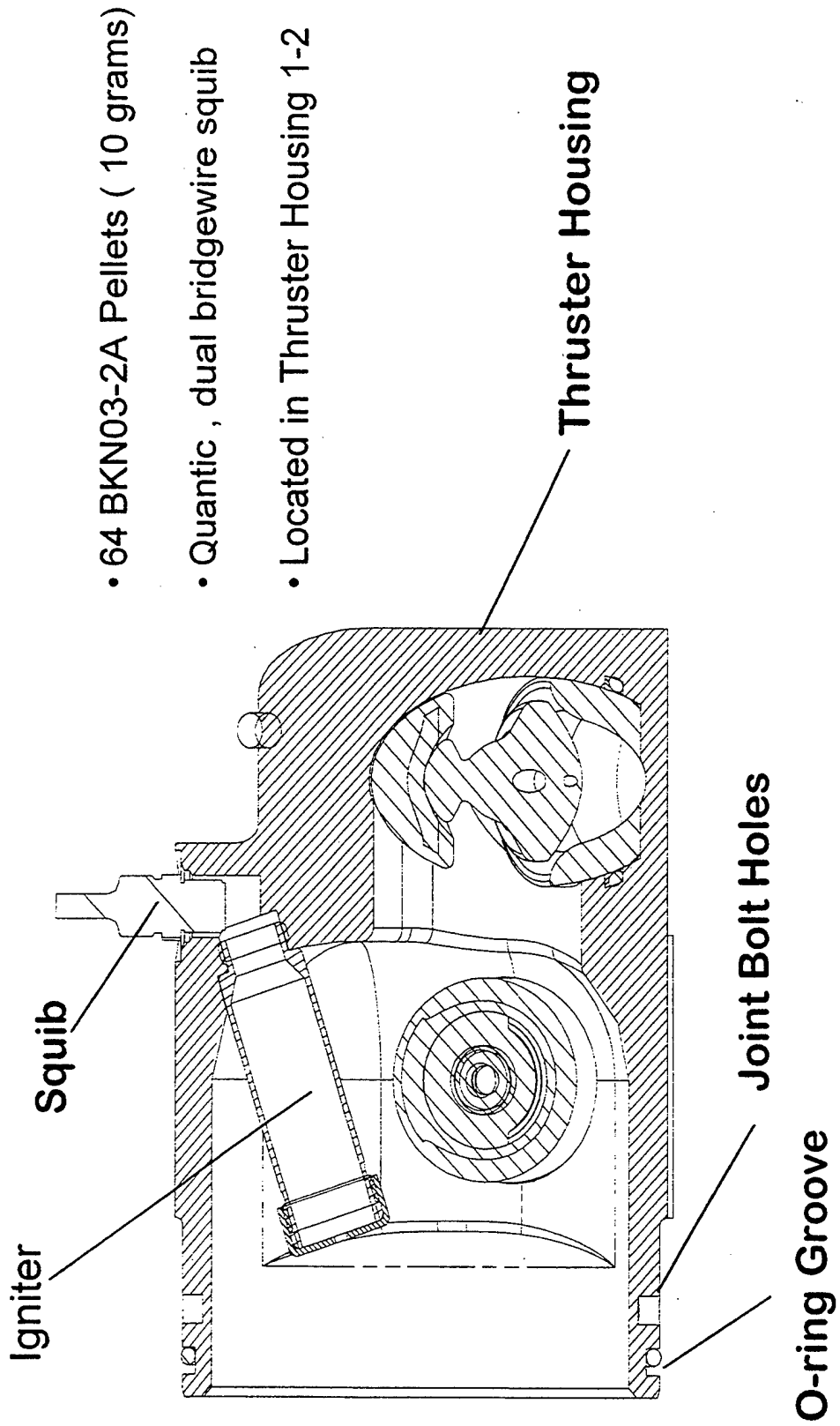

THRUSTER HOUSING, INSIDE VIEW

Small vertical text, likely a drawing number or reference code.

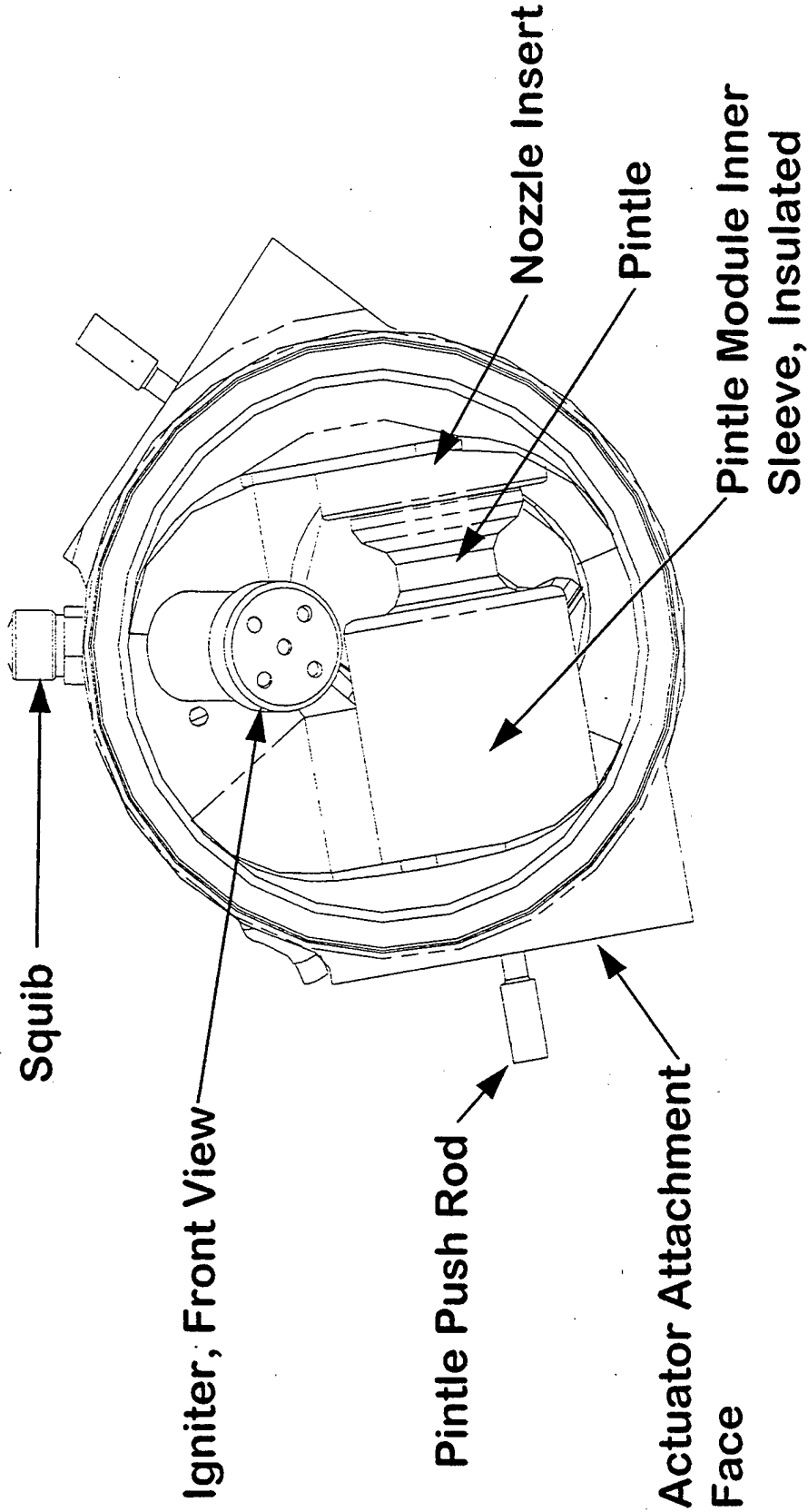



MAXPAC PROPELLANT

- 4.3 Pounds of Modified ANB-3679, Developed on the ARS Program
- Reduced Smoke, Hazards Class 1.3
- 7- Fin Grain Design, Full Length
- Elastomer Liner for Propellant to Case Bonding
- ~9.0 inches Long, ~ 3.8" OD, ~0.8" ID, ~ 0.3" Fin Gap

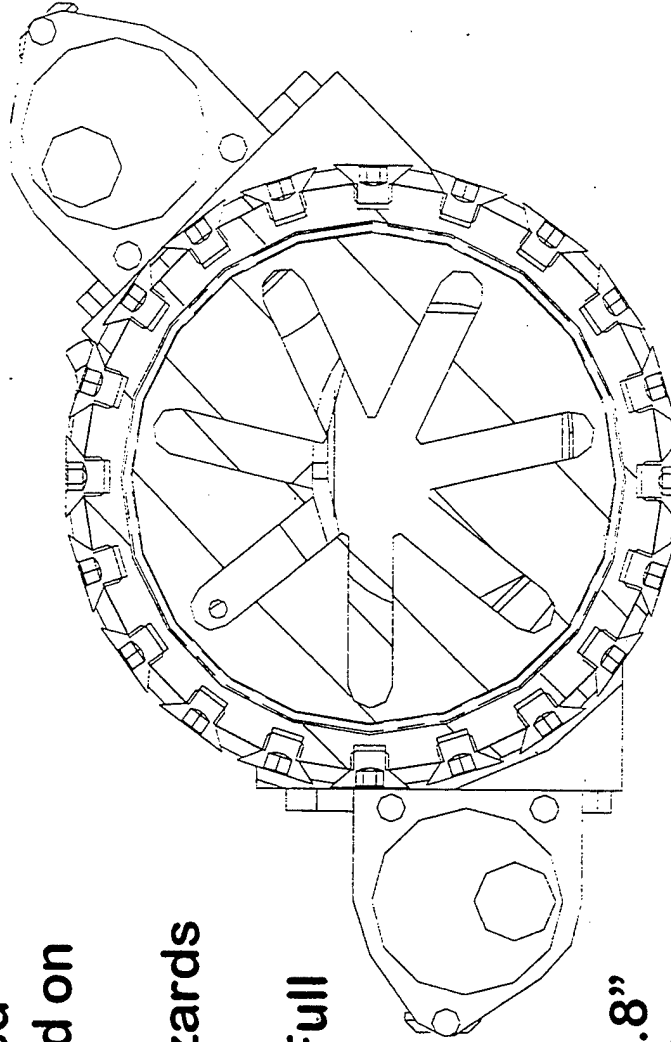

MAJOR COMPONENTS

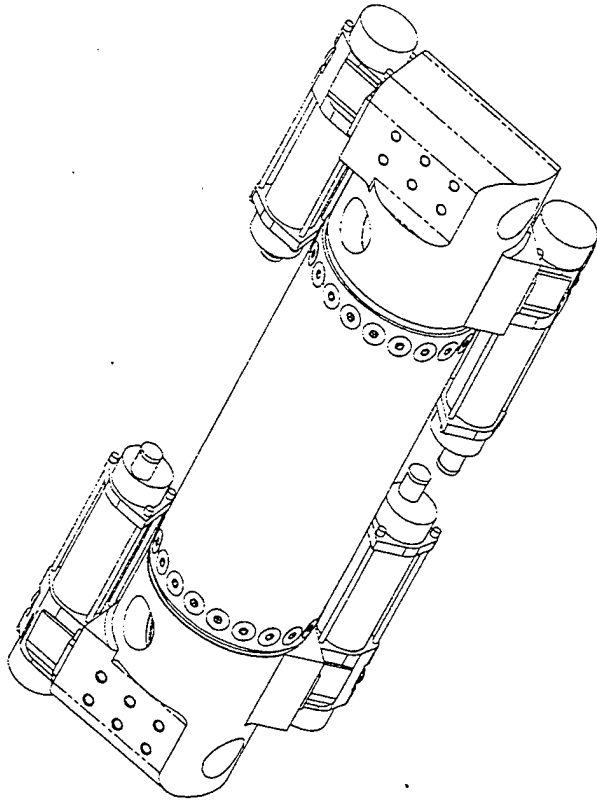

- 4- Electro-Mechanical Actuators
 - ✦ 150 VDC, 40 Amp
 - ✦ Stall Load >300 Lbf
 - ✦ Stroke > 0.22", > 120 Hz
- 1- Quad Actuator Controller
- 2- 5K Flightweight Paine Pressure Transducers, PN 177398
- 2- 5K Taber Pressure Transducers, Facility Equipment
- Kistler Load Measuring Table
- Motor Hold Down Brackets



CONTROLS

- **Control Logic in "C"**
- **EDACS (Engineering Data Acquisition and Control)**
 - » **Pentium 90MHz**
 - » **National Instruments Data Acquisition Boards**
 - » **Ectron Strain Gage Amplifiers**
 - » **Validyne Amplifiers**
 - » **Ordnance Firing Circuit**
- **Sample Rate of 400 Samples / Second**
- **Backup Data on Separate PC486/50**



CONTROL LOGIC

- **MAXPAC Control Logic Identical to 4TH GEN Initial Testing Logic**
- **Two Paine Amplified Pressure Transducers for Control**
- **Transducer Logic Checks for Bad Transducer**
- **Thrust Commands Limited to Available System Thrust**
- **Initial Pintle Positions at Spring 0-Load Point**
- **Versatron Actuators**
 - » **120 Hz Bandwidth**
 - » **15 Inches / Second**
 - » **360 lbf**
 - » **140 VDC @ 40 amps**

CONTROL LOGIC



- **MAXPAC Control Logic Identical to 4TH GEN Initial Testing Logic**
- **Two Paine Amplified Pressure Transducers for Control**
- **Transducer Logic Checks for Bad Transducer**
- **Thrust Commands Limited to Available System Thrust**
- **Initial Pintle Positions at Spring 0-Load Point**
- **Versatron Actuators**
 - » **120 Hz Bandwidth**
 - » **15 Inches / Second**
 - » **360 lbf**
 - » **140 VDC @ 40 amps**

MAXPAC GROUND TESTING ELECTRICAL INTERFACE

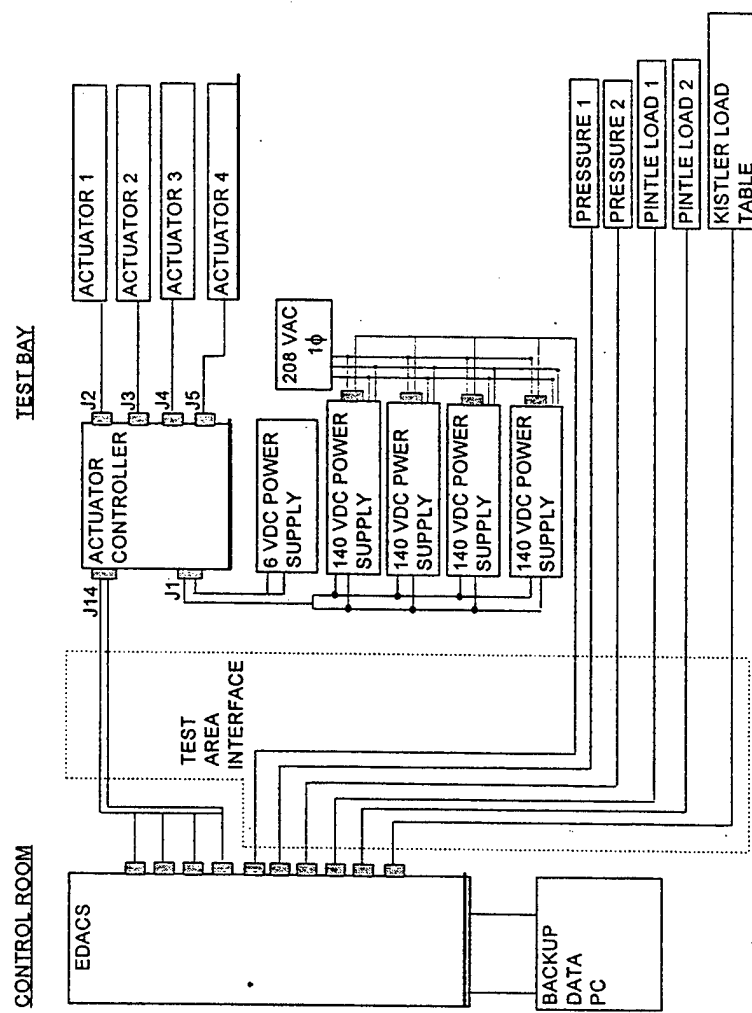

MAXPAC INSTRUMENTATION LIST



| Function | Name | Range | Notes |
|--------------------------------|------------------|-------------------|---------------|
| Chamber Pressure | PC - 1 & 2 | 0 - 5,000 psia | 2Paines-2Tbrs |
| Igniter Circuit Current | II - 1 | TBD amps | |
| Pintle Actuators (1-4) Current | IAP-1 thru IAP-4 | 0 -40 amps | |
| Pintle Actuators (1-4) Voltage | EAP-1 thru EAP-4 | 0 - 1400 volts | |
| Pintle #1 Actuator Command | CAP-1 thru CAP-4 | 0 - 10 volts | |
| Pintle Position | PP-1 thru PP-4 | 0 - 0.25 inch | |
| Forces along X, Y Axes | FX, FY | ± 4496 lbf | Tests 2 & 3 |
| Forces along Z Axis | FZ | -4496 to 8993 lbf | Tests 2 & 3 |
| Moments about X, Y Axes | MX, MY | ± 369 ft-lbs | Tests 2 & 3 |
| Moments about Z Axis | MZ | ± 738 ft-lbs | Tests 2 & 3 |

KISTLER LOAD

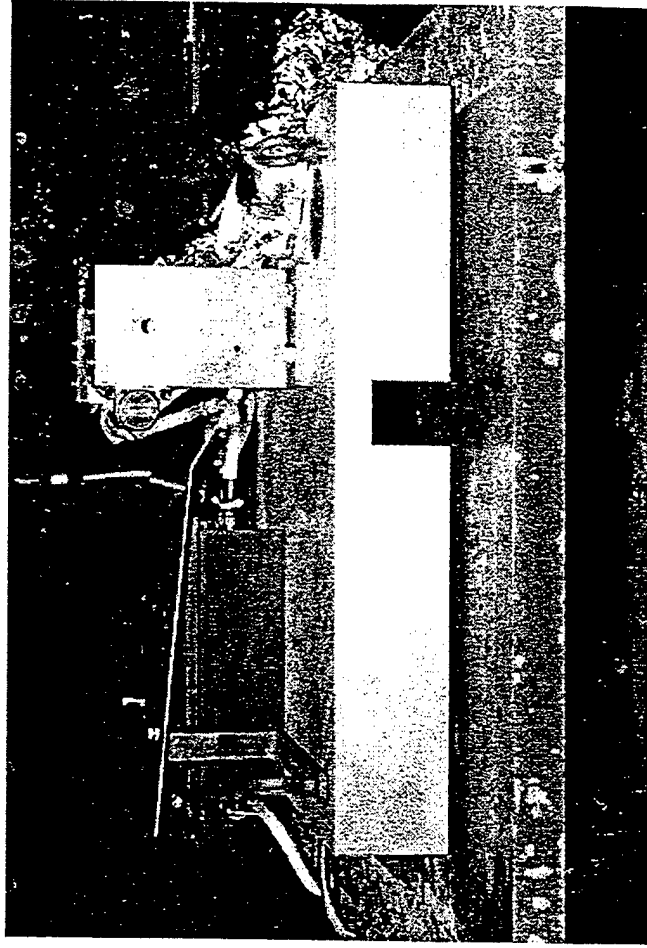

- Multi-component Force Plate Provides 3 Orthogonal Components Of Force, Fx, Fy, & Fz
- $F_x \& y = + 4496$ lbf; $F_z = -4496$ to 8993 lbf
- High Frequency due to Stiffness
- 4 - 3 axis Quartz Type Load Cells
- Micro-Processor/ Amplifier, Determines Moments and Resultant Forces

GENCORP
AEROJET

KISTLER LOAD TABLE REAR VIEW

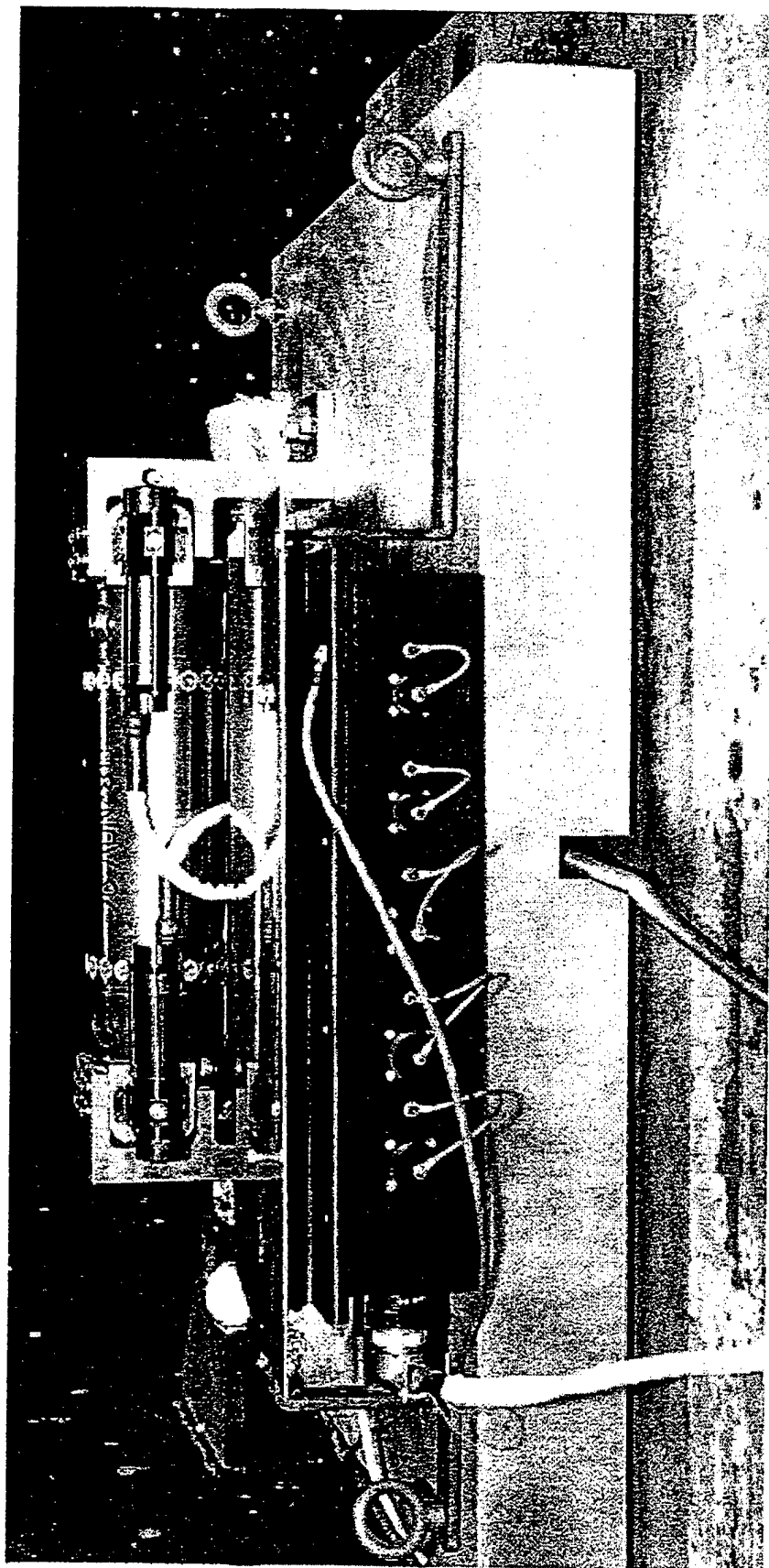

PROOF TEST CRITERIA & RESULTS



Approved for Release by NSA on 05-08-2013 pursuant to E.O. 13526

- **Hydro-Proof Test**
 - ✦ Motor Assembled as Planned with Nozzle Plugs
 - ✦ Max Pressure 4600 psi
- **Motor Held Target Pressure for 60 Seconds**
- **Joint Failed- Bolts Pulled from Bolt Hole: Bolt L/D was to Small, < 0.7 Critical Ratio**

20- 1/4" x 28 screws
1/8 Long

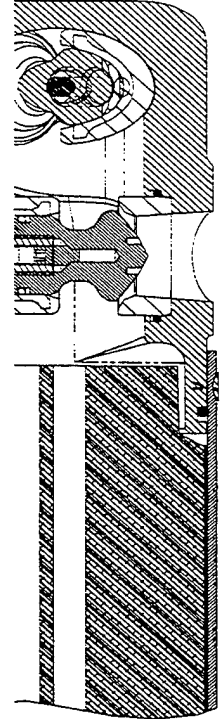
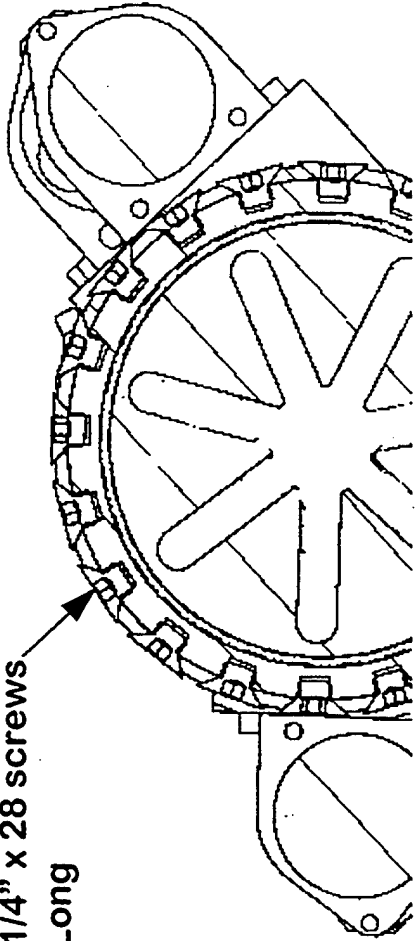

Posttest Bolt Centerline
Pretest Centerline

MOTOR CASE JOINT NEAR TERM FIX



- Brainstorming Session Lead to Near Term Fix
 - ✦ Salvage Existing Hardware
 - ✦ Must Use Larger Bolts
 - ✦ Drill Through Thruster Housing To Acquire More Length
 - ✦ Bond in Stainless Steel Shim
 - ✦ Coat Shim Joint with vulcanized rubber
 - ✦ Consequently Increased L/D
- Long Term Fix, Redesigned Joint, Probably Lockwire

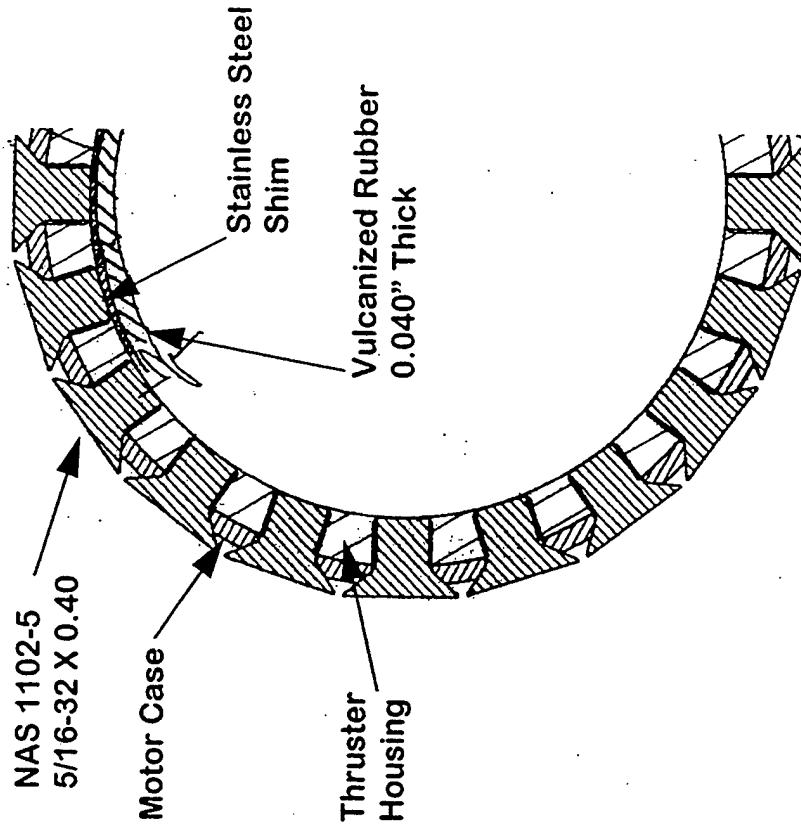

**GENCORP
AEROJET**



MAXPAC TEST DATA REVIEW AND GROUND TEST GROUNDING ISSUES

KEVIN PETERSON

MAXPAC TEST 100 RESULTS



- Pressure Rise Normal on Number 1 Side
- Pressure Port Blocked on Number 2 Side
- Pressure Dropped Due to Abort
- Pressure Rise at End When Pintles Moved to No Load Point

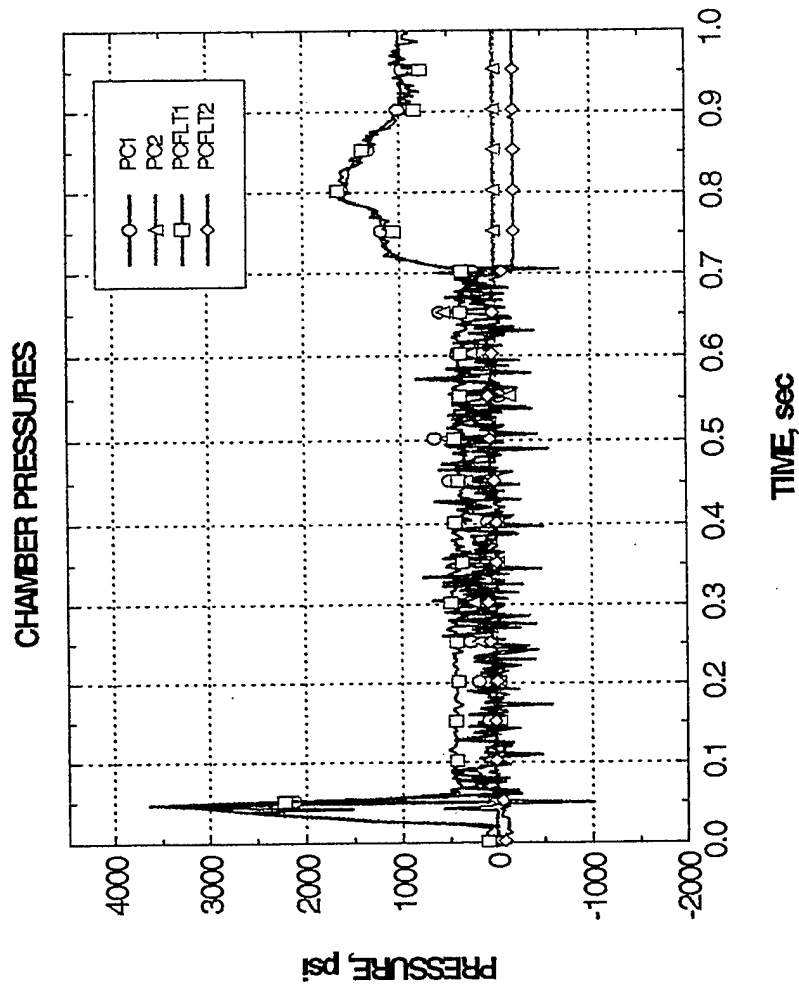



MAXPAC TEST 100 RESULTS

- Control Pressure
2 Thrown Out Due
to Delta PC > 200
for 6 Continuous
Samples
- Control Pressure
1 Thrown Out Due
to 3 Continuous
Samples of
PC < -150 or
PC > 5000
- Both Transducers
Bad, Test Aborted

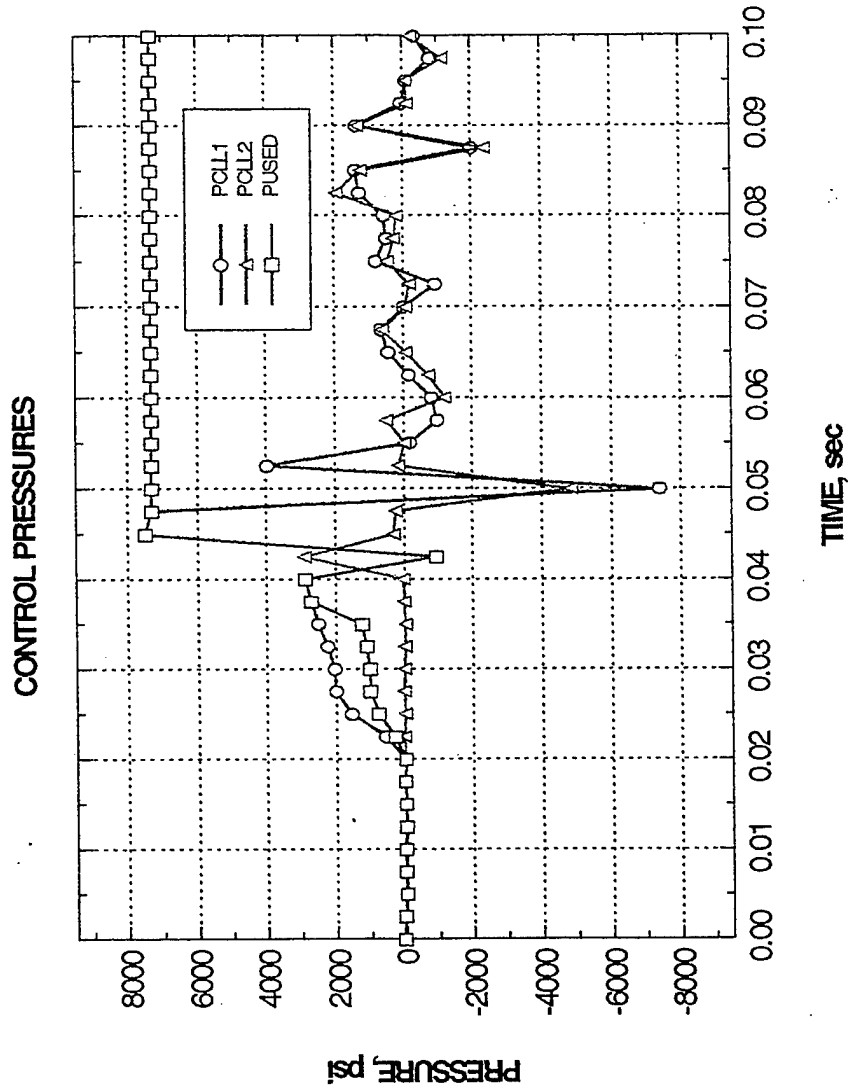

MAXPAC TEST 100 RESULTS



- Pressure Transducer
1 Failure Caused by
Noise
- Noise Occurred
When Actuator
Current Increased

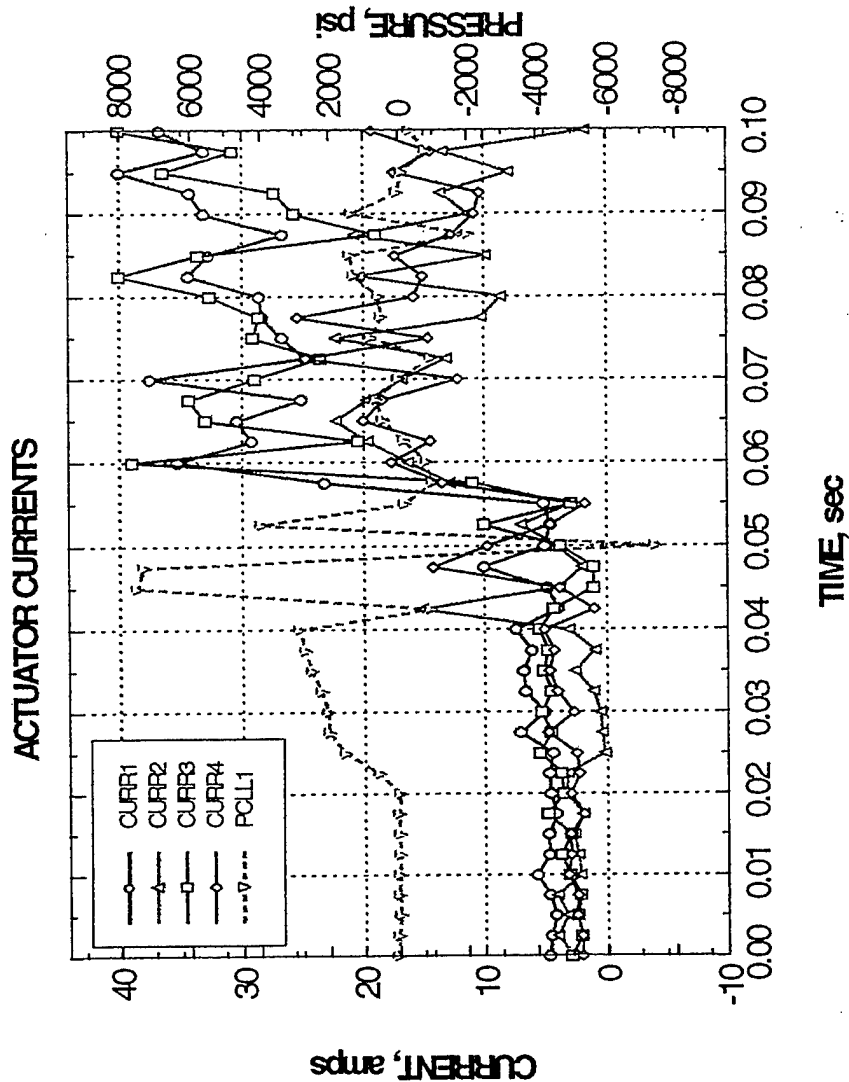



MAXPAC NOISE ISSUES

- **Noise on Pressure Transducer Feedback Signals**
 - ✦ **Both The Facility Tabers And The Paine Flight Transducers**
- **Noise Appeared When Actuators Energized**
- **Noise Increased With Increased Actuator Current Draw**
- **Noise Caused Abort on Test 100**



Noise Elimination Solutions

- Versatron Suggested Batteries for Actuator Power
 - ✦ Noise Significantly Reduced, But Not Eliminated
- Next Step, Grounding
 - ✦ Common Ground Between Actuator Controller and D/A Card
 - ✦ Common Ground Between Signal Conditioners
 - ✦ Tied Actuator Controller Case to Earth Ground
 - ✦ Tied All Shields to Instrumentation Ground
- Noise Reduced to Acceptable Level on Taber Transducers
(± 10 psi)



GENCORP
AEROJET

MAXPAC TEST 200 RESULTS

DUTY CYCLE

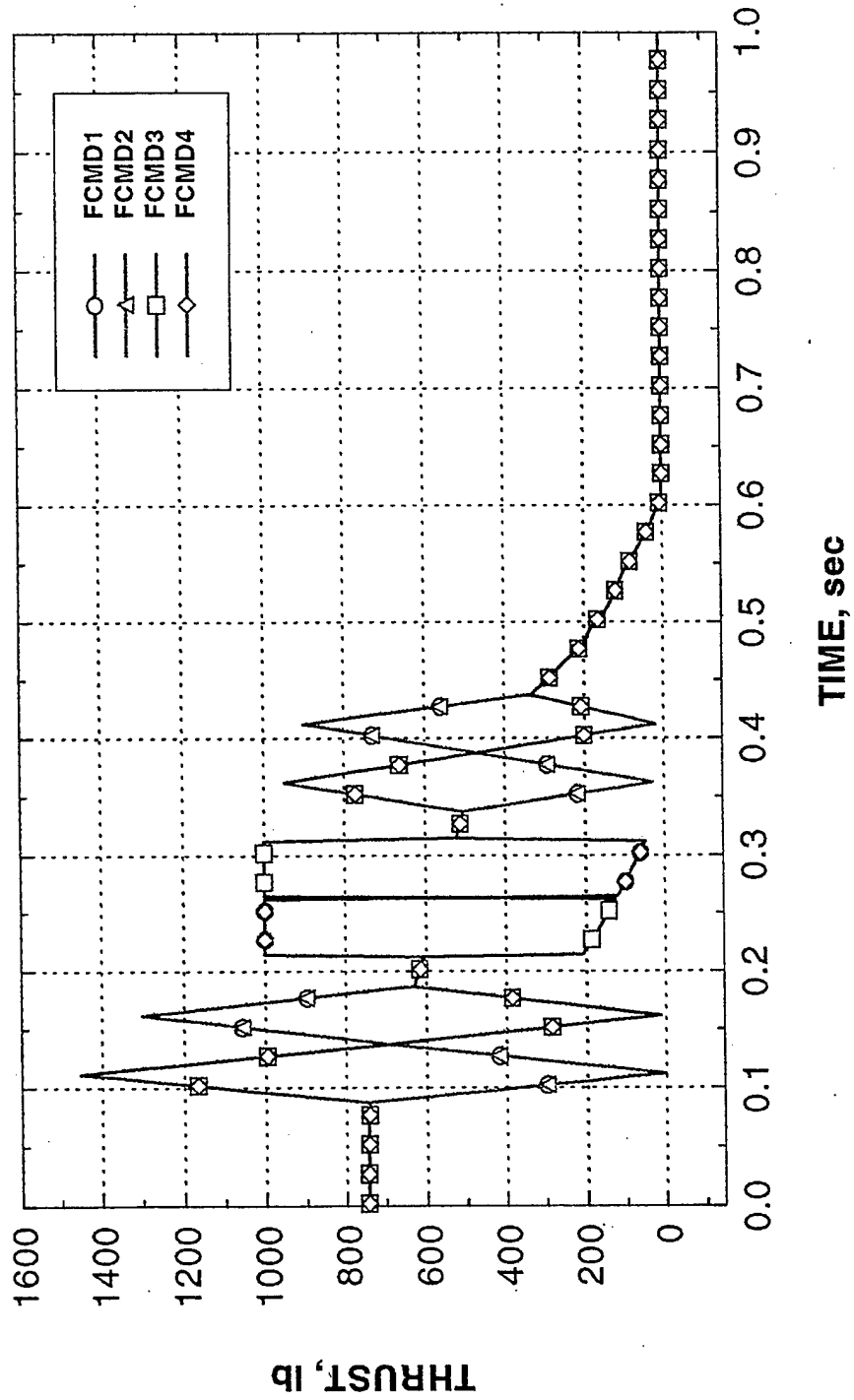

MAXPAC TEST 200 RESULTS



- Noise Effectively Eliminated
- Paine Flightweight Transducers Matched Facility Tabers
- Pressure Variations of 500 psi
- Burn Time Approximately 0.1 sec < Predicted
- ✦ Possibly Burn Rate Variation

TABER AND PAINE TRANSDUCERS

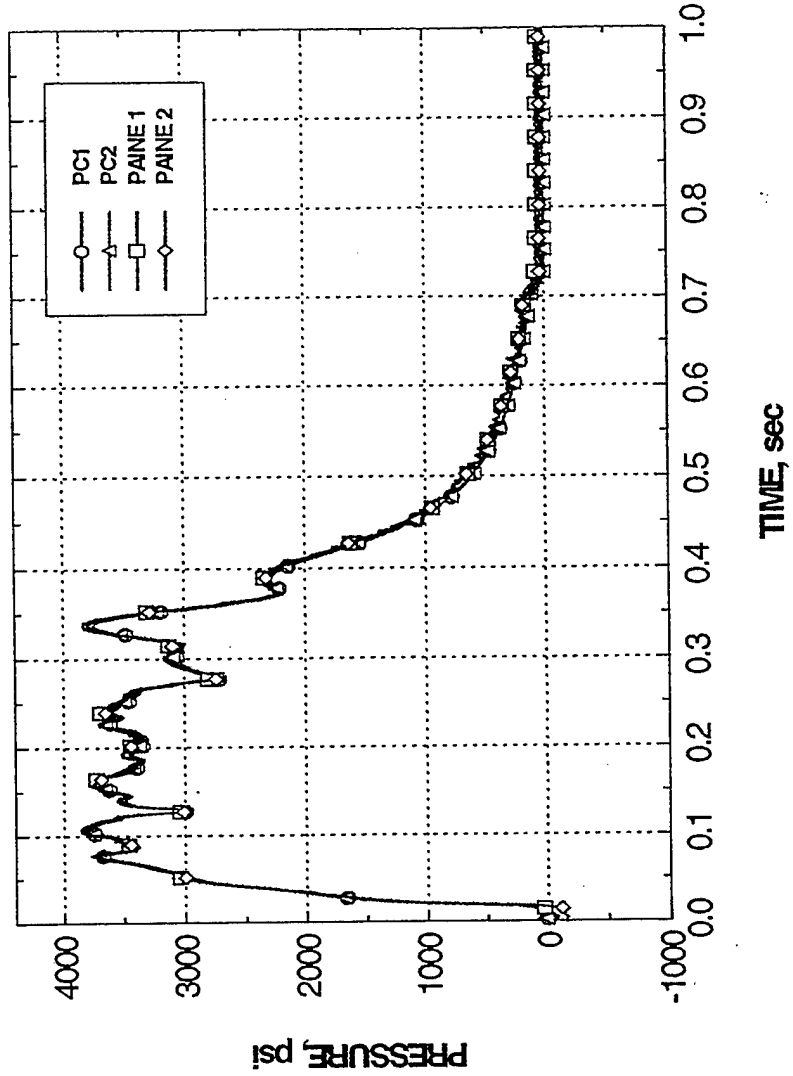

MAXPAC TEST 200 RESULTS



- Pintles Followed Commands
- Springs Appear to Work as Designed
- Cause of Spikes in Data Unknown
 - ✦ Noise
 - ✦ Spring Effects
- Pintle 2 Sticks After 0.3 seconds
 - ✦ Evidence of Igniter Welding

PINTLE POSITIONS

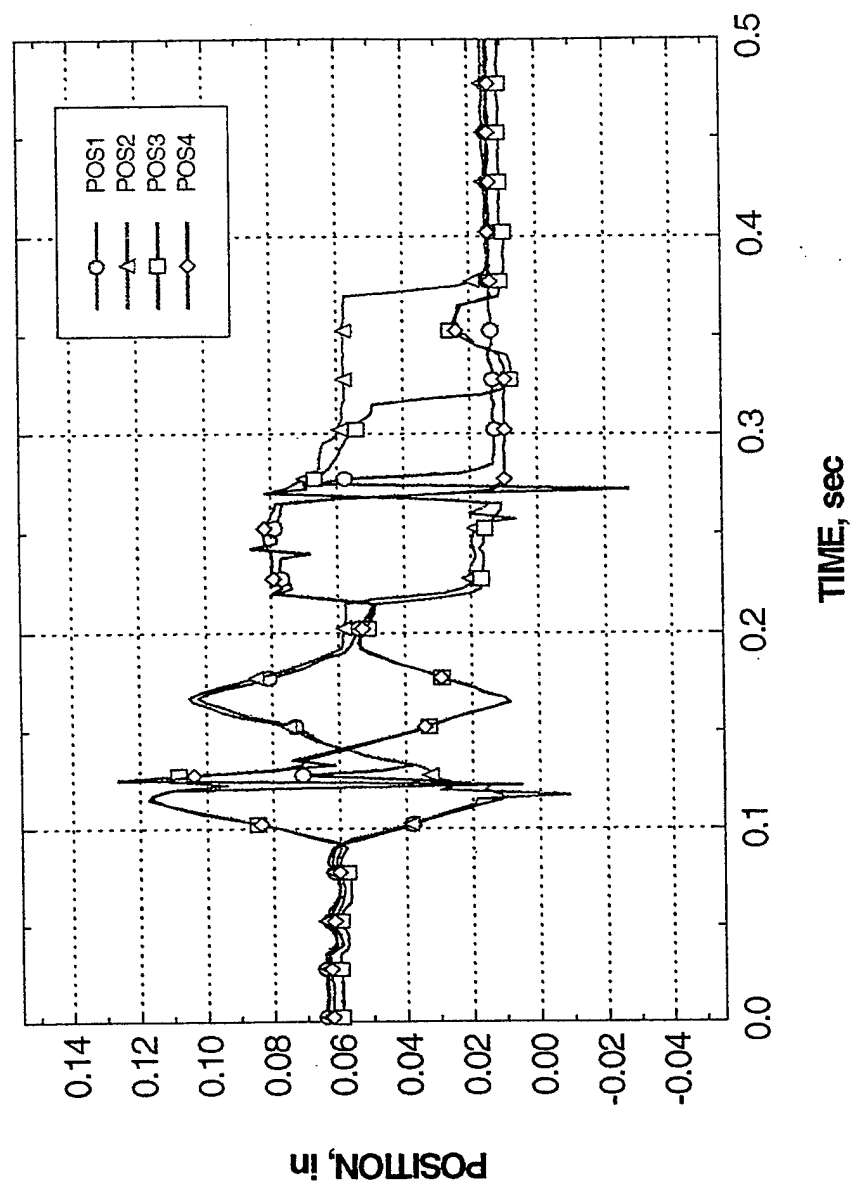

MAXPAC TEST 200 RESULTS



- Theoretical Pintle Loads Kept Below 200 lbs

CALCULATED PINTLE LOAD #1

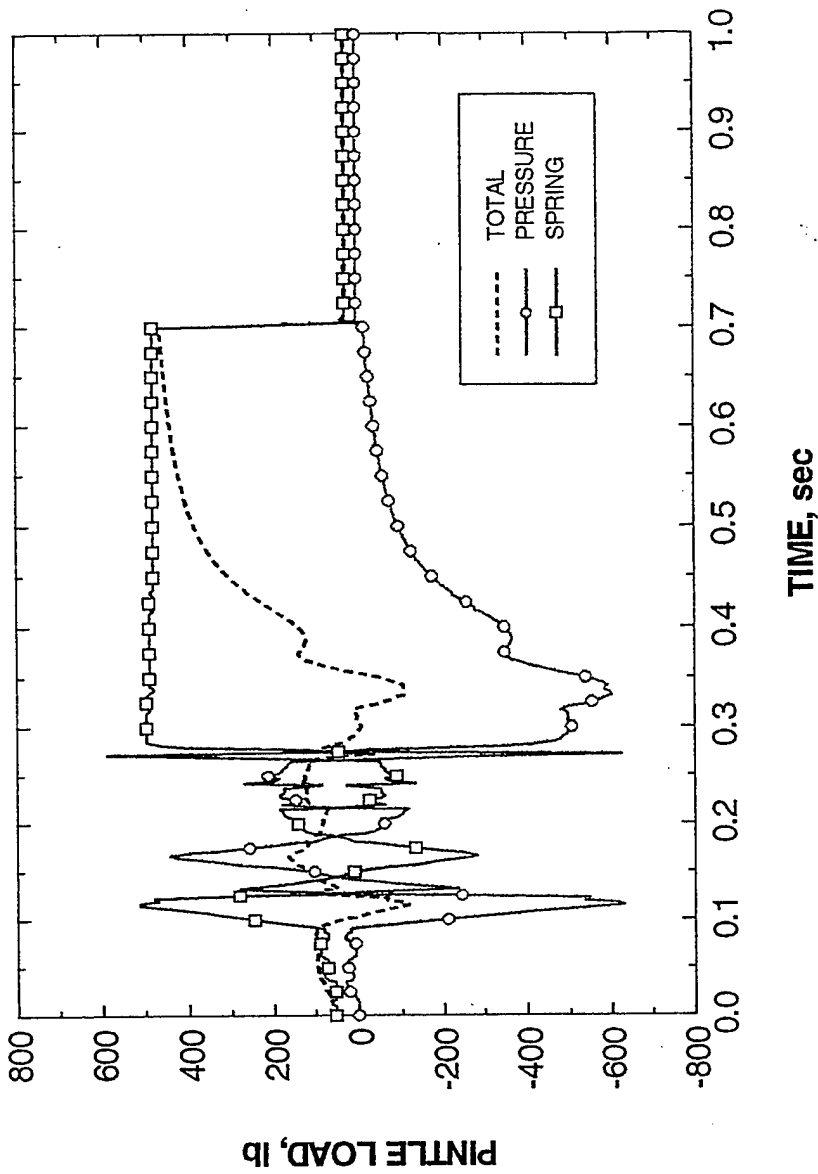



GENCORP.
AEROJET

MAXPAC TEST DATA

Kistler Load Table

- A Multicomponent Force Plate
 - ✦ Consists of Four Tri-Axis Load Cells
 - Separate Multichannel Charge Amplifier
 - Outputs the Following Measurements
 - ✦ Fx1+2 X-Axis Load Cell 1 & 2
 - ✦ Fx3+4 X-Axis Load Cell 3 & 4
 - ✦ Fy1+4 Y-Axis Load Cell 1 & 4
 - ✦ Fy2+3 Y-Axis Load Cell 2 & 3
 - ✦ Fz1 Z-Axis Load Cell 1
 - ✦ Fz2 Z-Axis Load Cell 2
 - ✦ Fz3 Z-Axis Load Cell 3
 - ✦ Fz4 Z-Axis Load Cell 4
 - ✦ 1/2 Fx 1/2 X-Axis Thrust
 - ✦ 1/2 Fy 1/2 Y-Axis Thrust
 - ✦ 1/4 Fz 1/2 Z-Axis Thrust
 - ✦ 1/4 Mx 1/4 Moment About X-Axis
 - ✦ 1/4 My 1/4 Moment About Y-Axis
 - ✦ 1/4 Mz 1/4 Moment About Z-Axis

MAXPAC TEST 200 RESULTS



X-AXIS THRUST

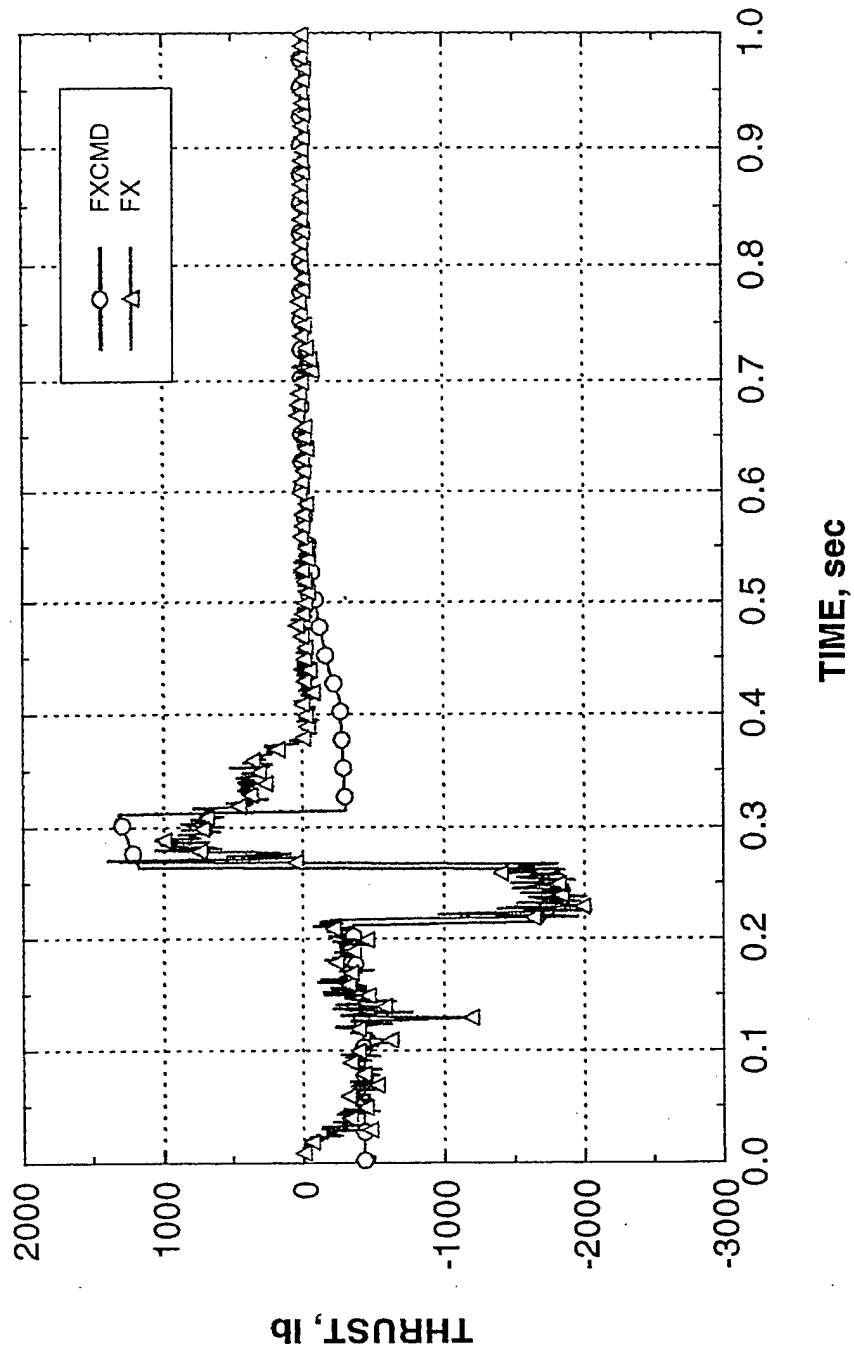



GENCORP
AEROJET

MAXPAC TEST 200 RESULTS

Z-AXIS THRUST

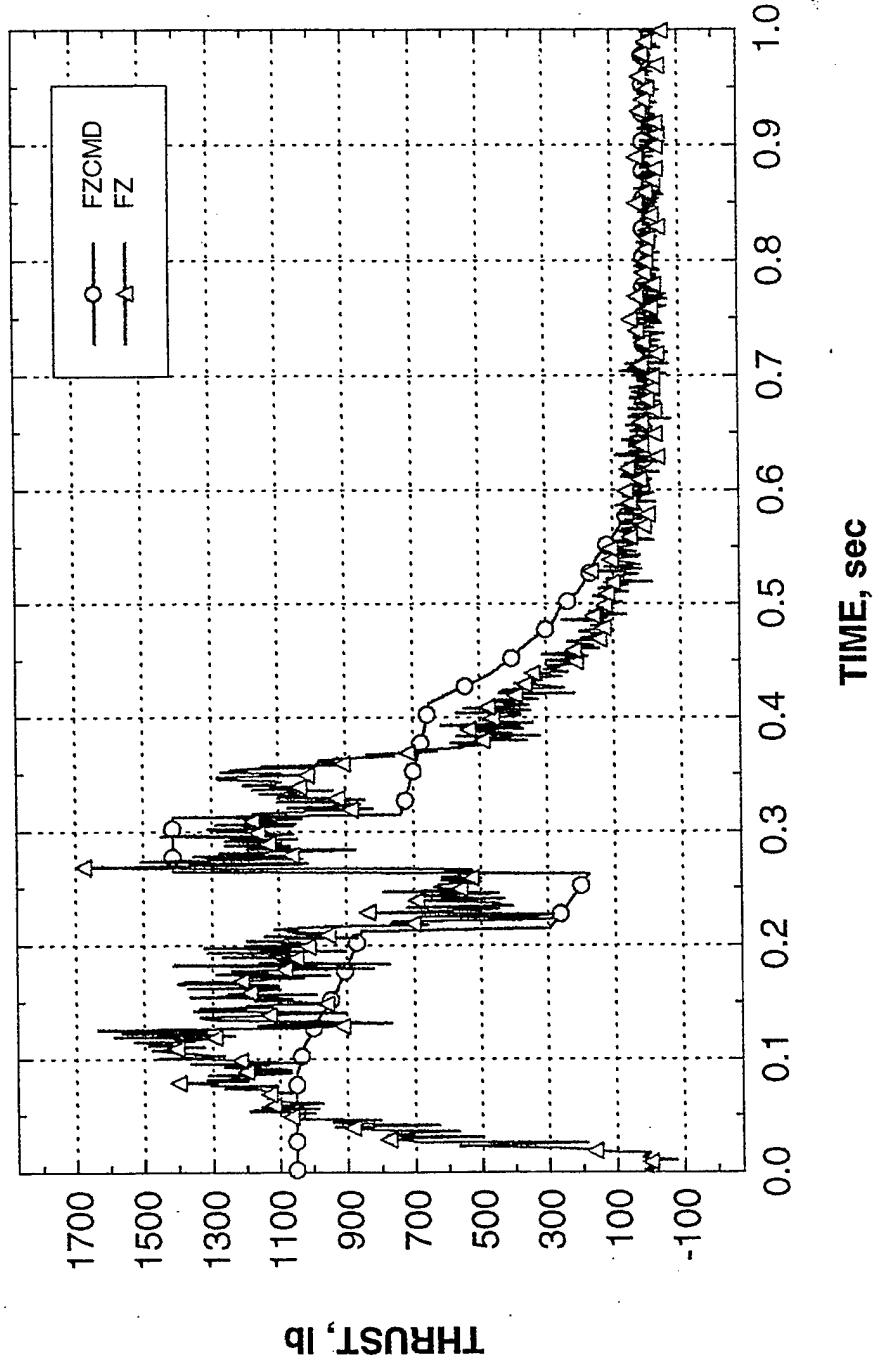

MAXPAC TEST 200 RESULTS



X-AXIS MOMENT

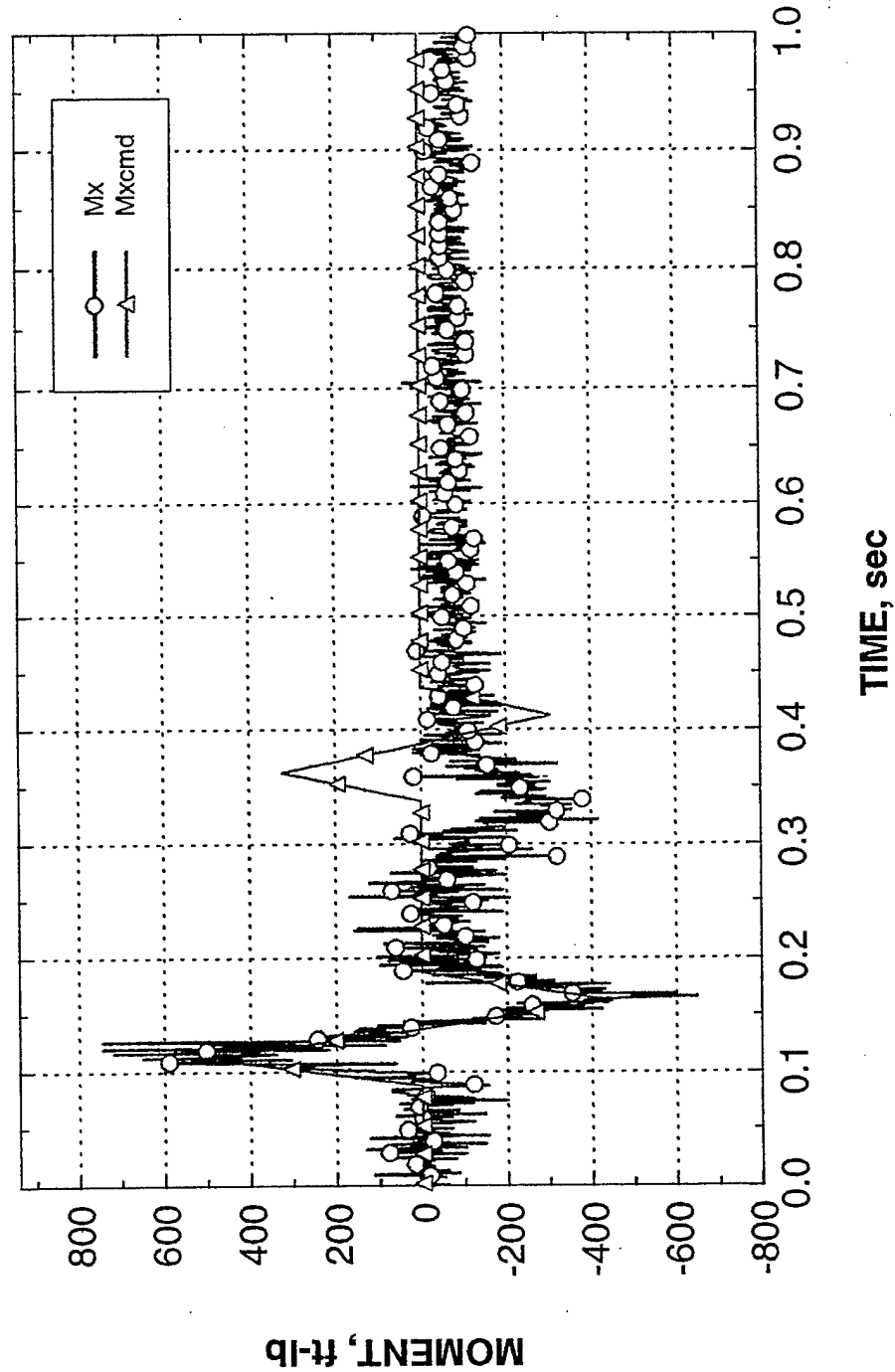



**GENCORP
AEROJET**

MAXPAC TEST 200 RESULTS

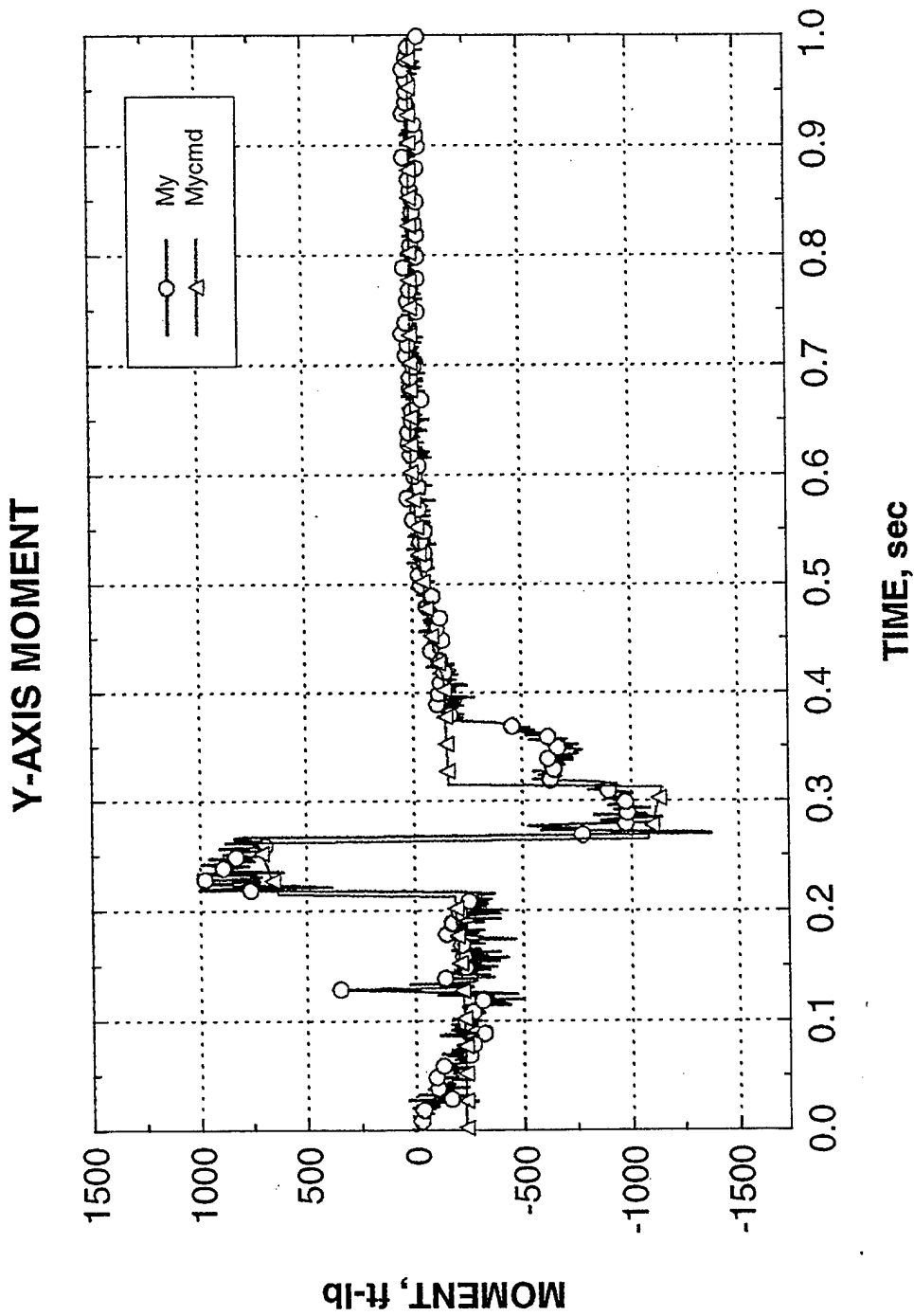

MAXPAC TEST 200 RESULTS



Z-AXIS MOMENT

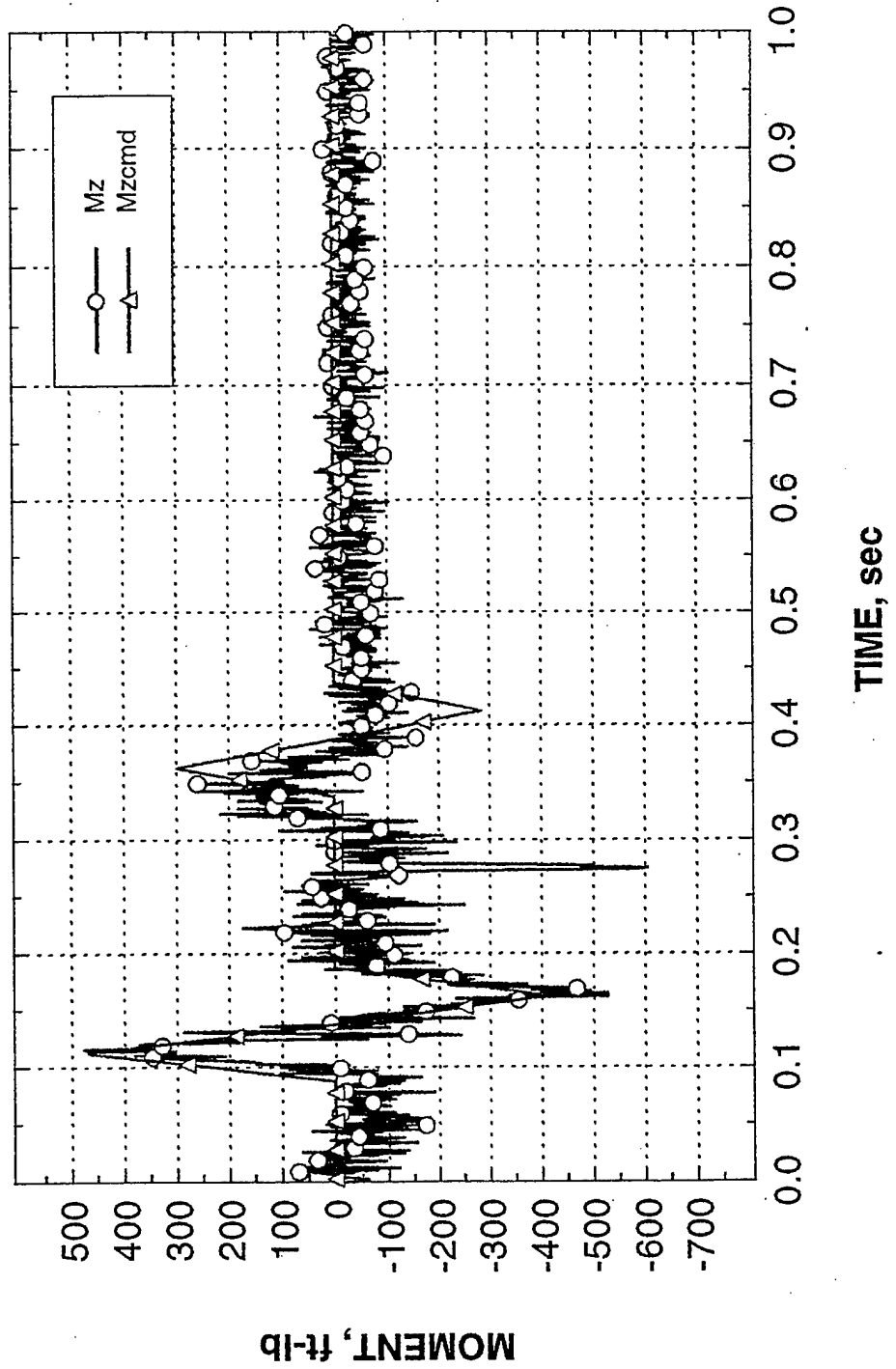



GENCORP
AEROJET

MAXPAC TEST 200 RESULTS

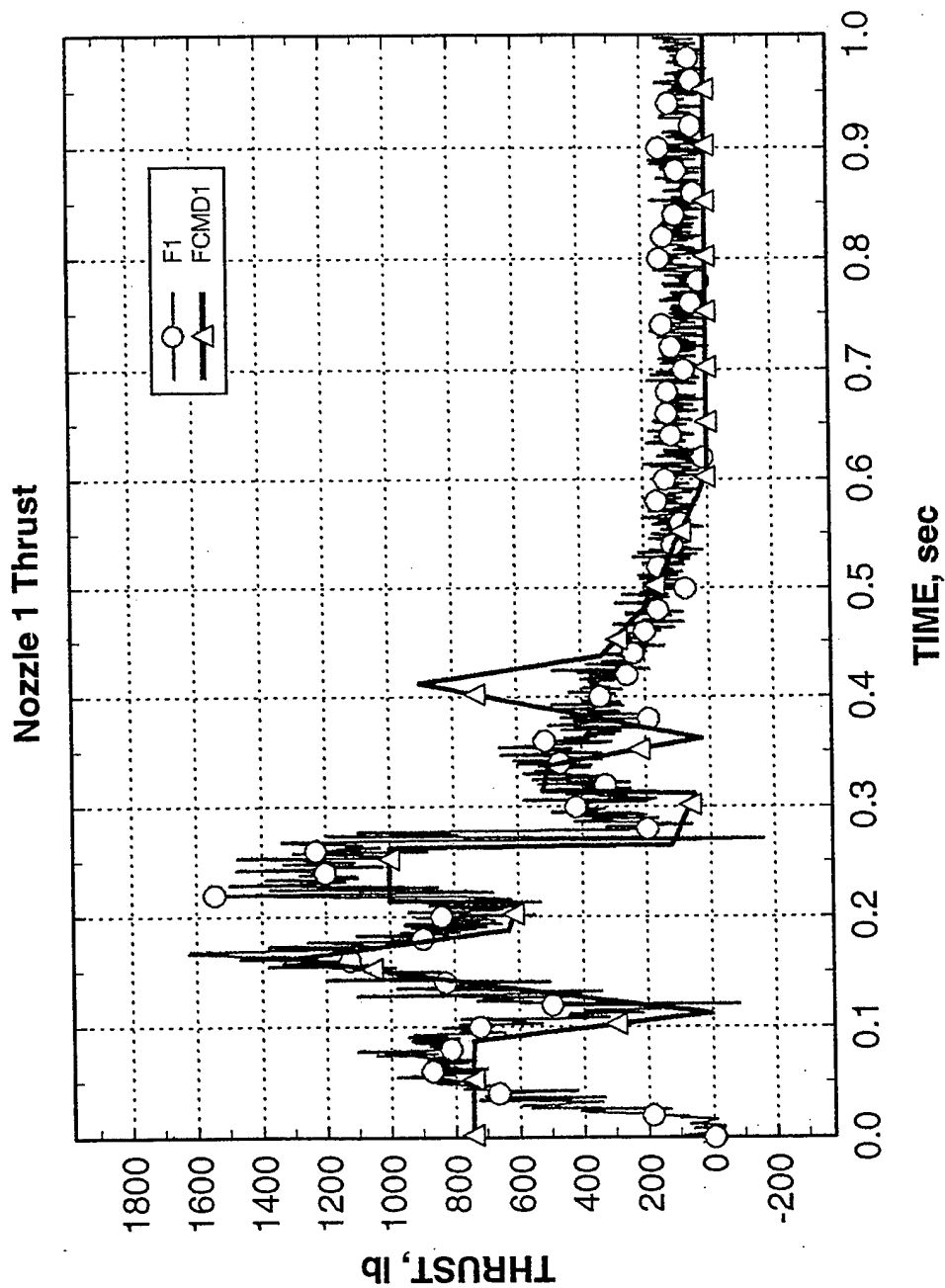



GENCORP
AERDJET

MAXPAC TEST 200 RESULTS

Nozzle 2 Thrust

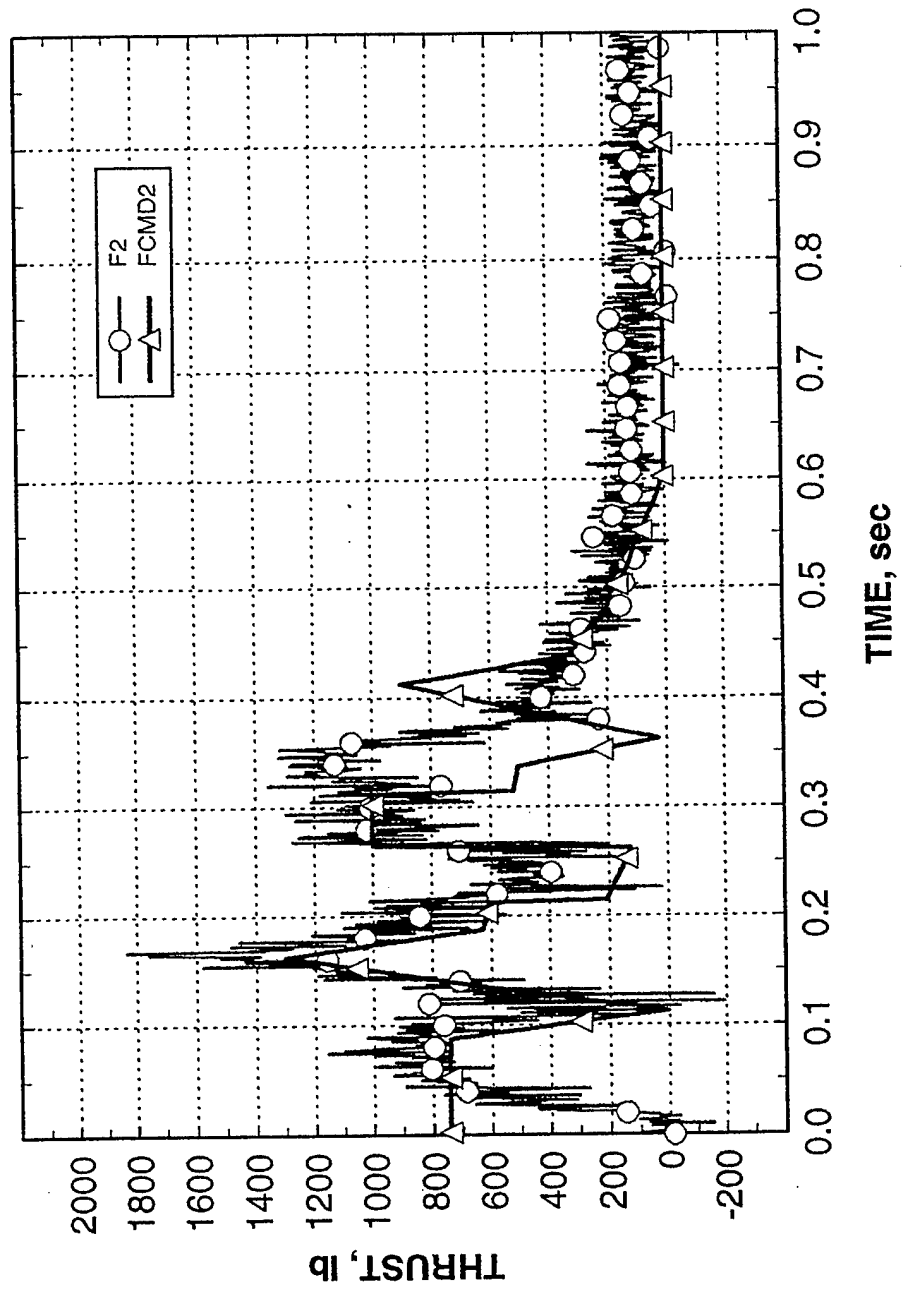

MAXPAC TEST 200 RESULTS



Nozzle 3 Thrust

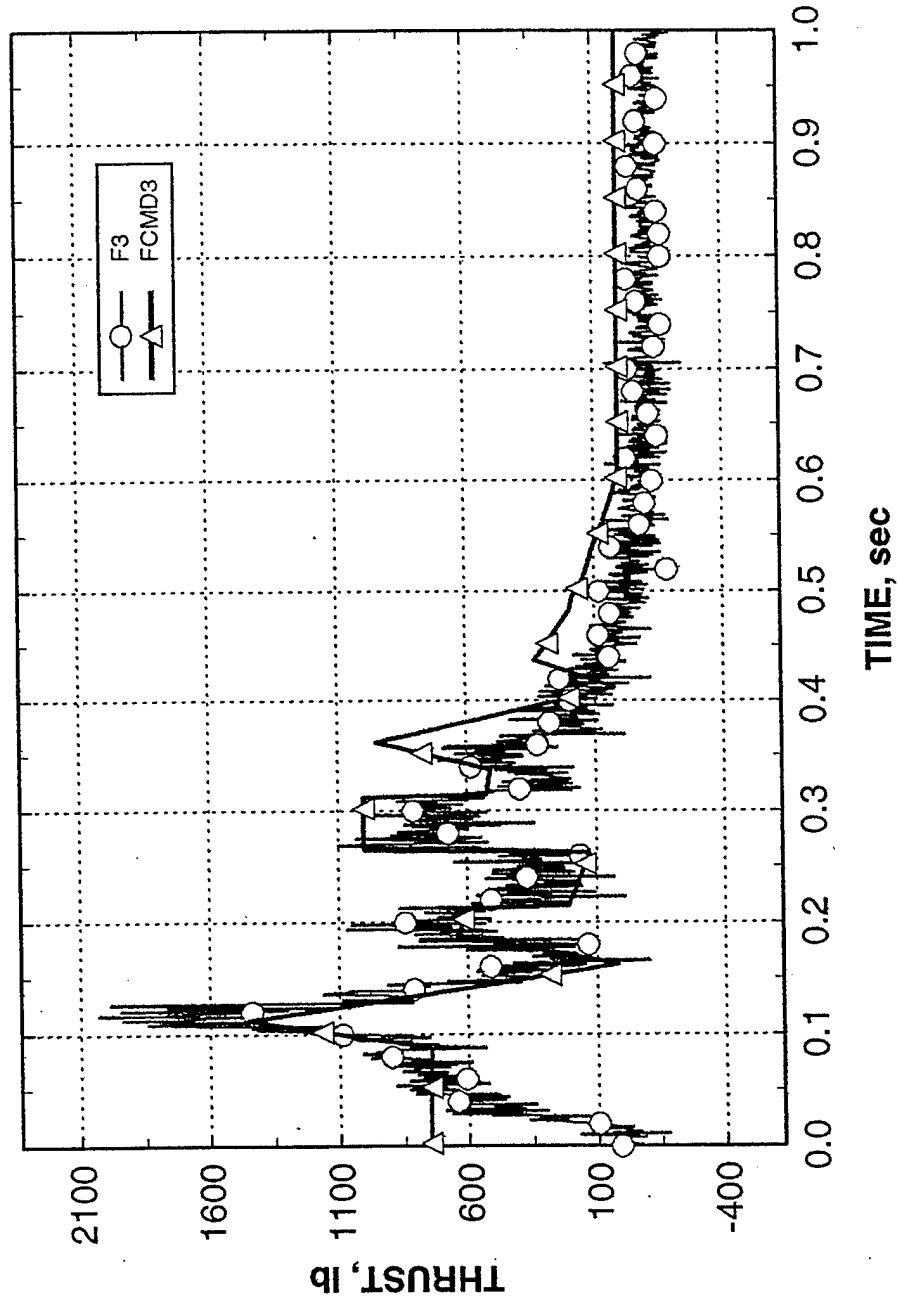

MAXPAC TEST 200 RESULTS



Nozzle 4 Thrust

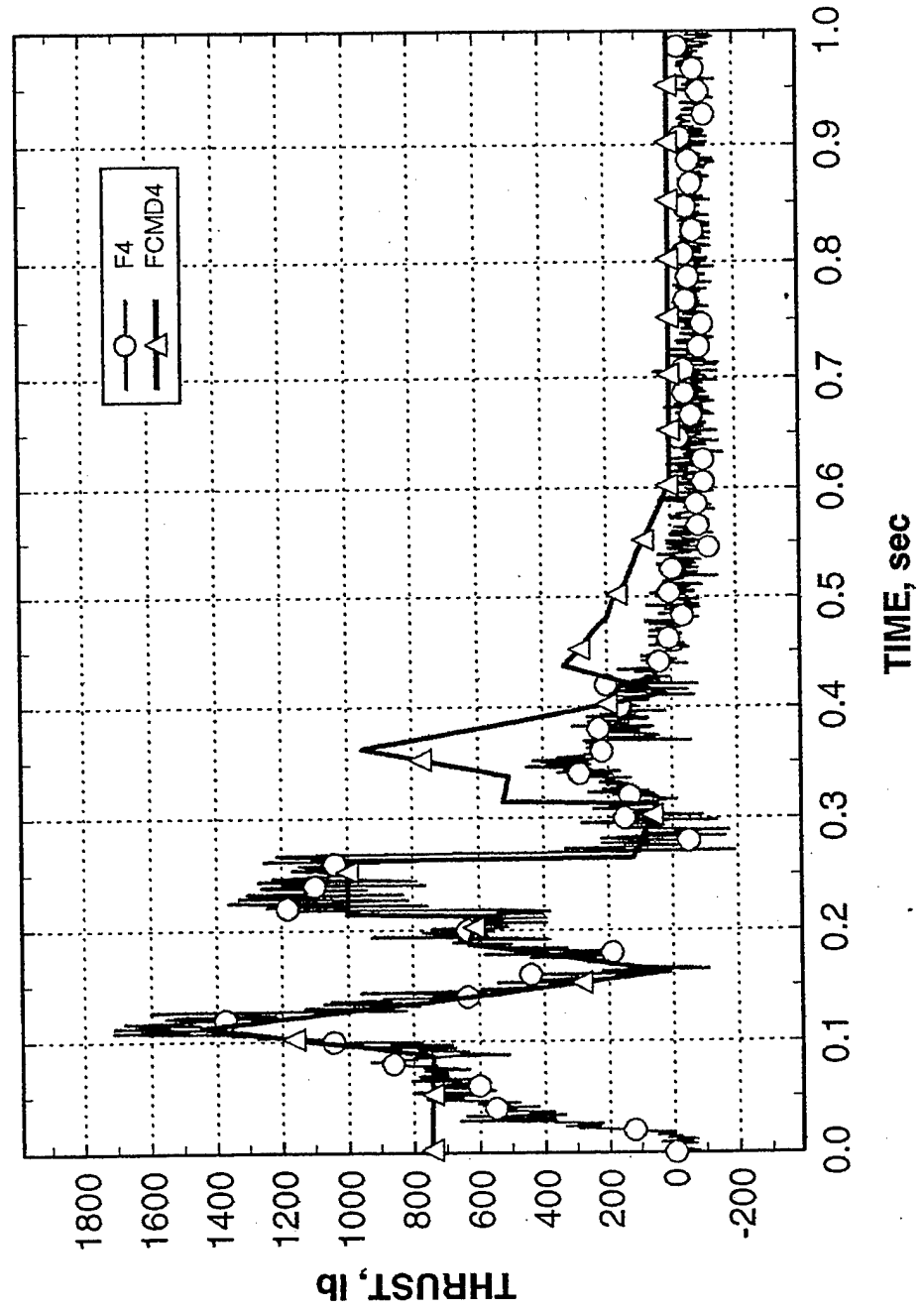



**GENCORP
AEROJET**

MAXPAC TEST 300 RESULTS

THRUST COMMANDS

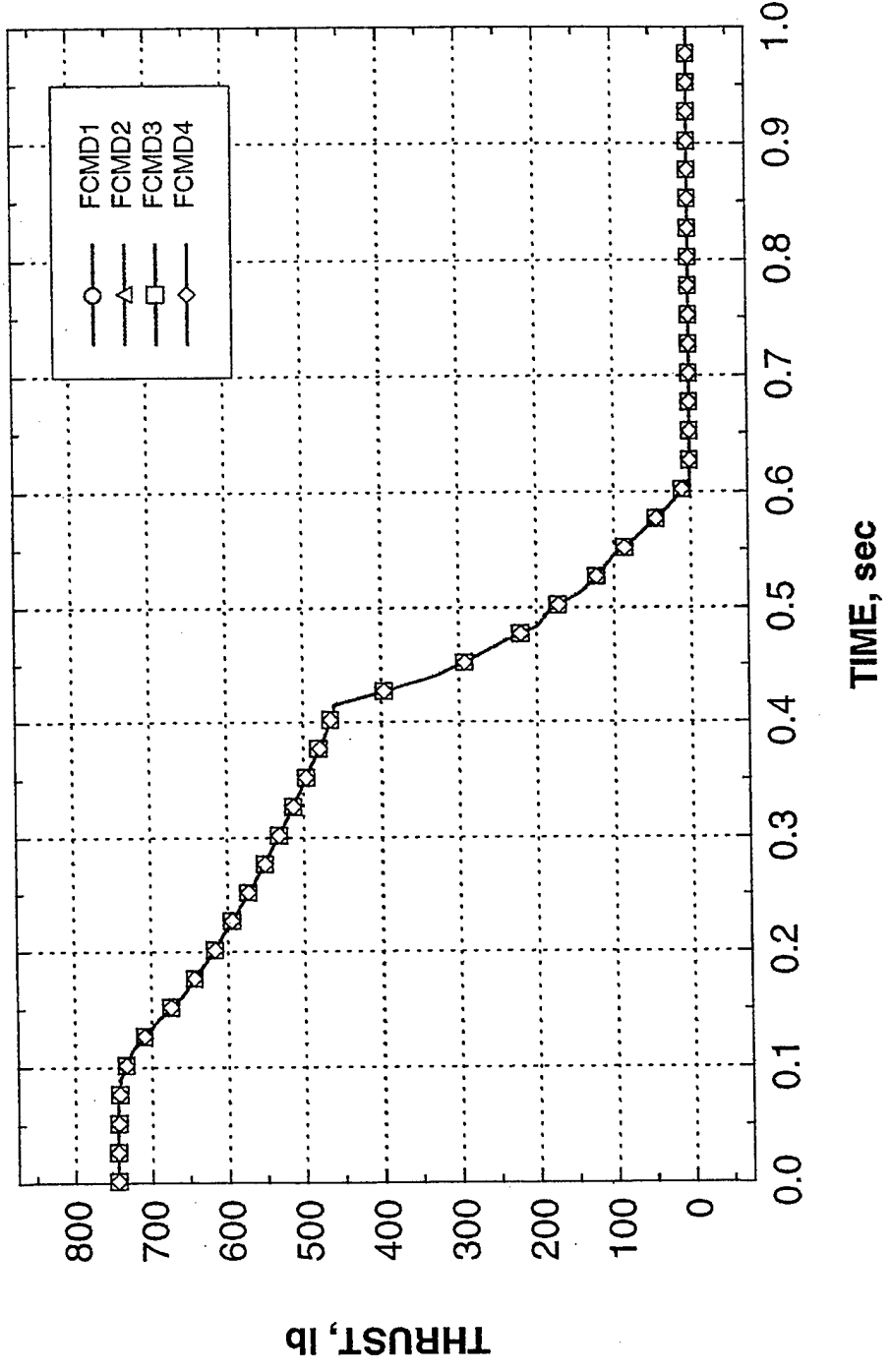

MAXPAC TEST 300 RESULTS



TABER AND PAINE TRANSDUCERS

- Paine Flightweight Transducers Matched Facility Tabers
- Pressure Variations of 300 psi
- Burn Time Approximately 0.1 sec < Predicted
- ✦ Possibly Burn Rate Variation

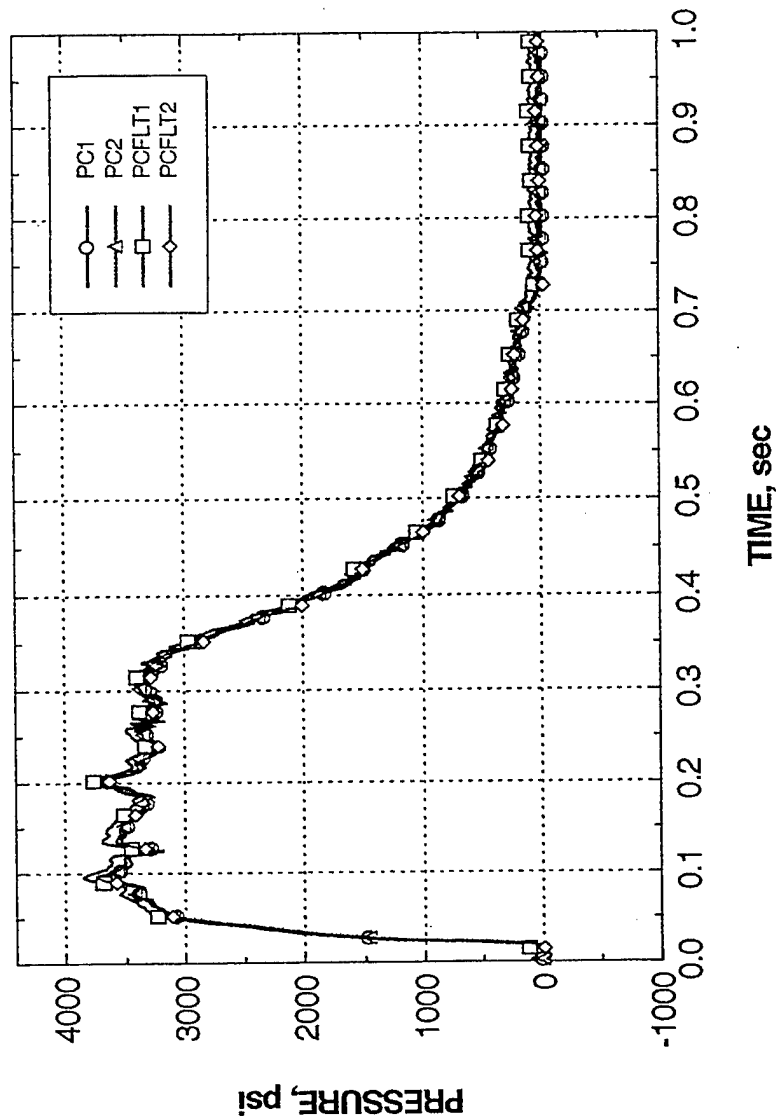



GENCORP
AEROJET

MAXPAC TEST 300 RESULTS

X-AXIS THRUST

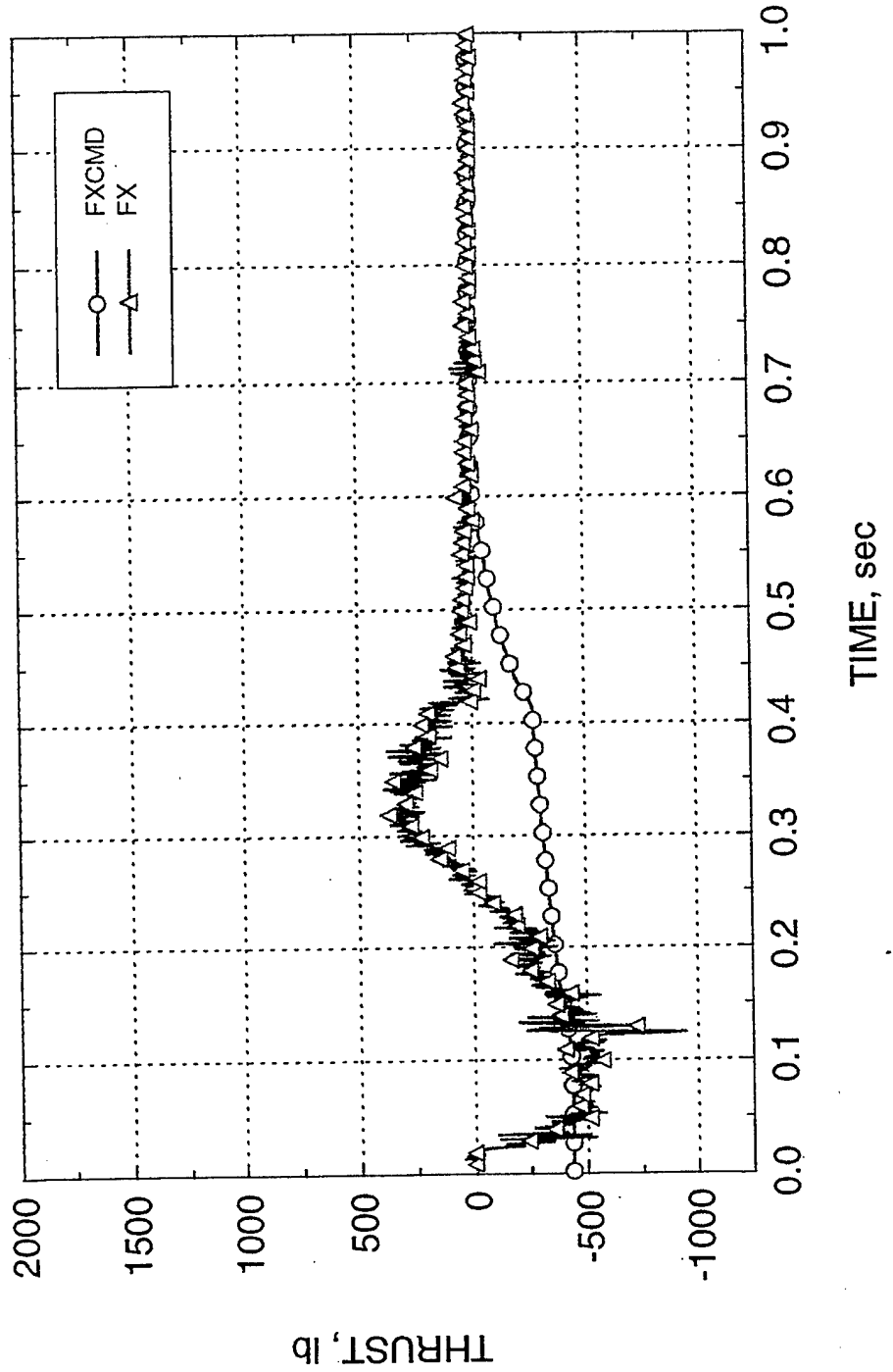



GENCORP
AEROJET

MAXPAC TEST 300 RESULTS

Z-AXIS TRUST

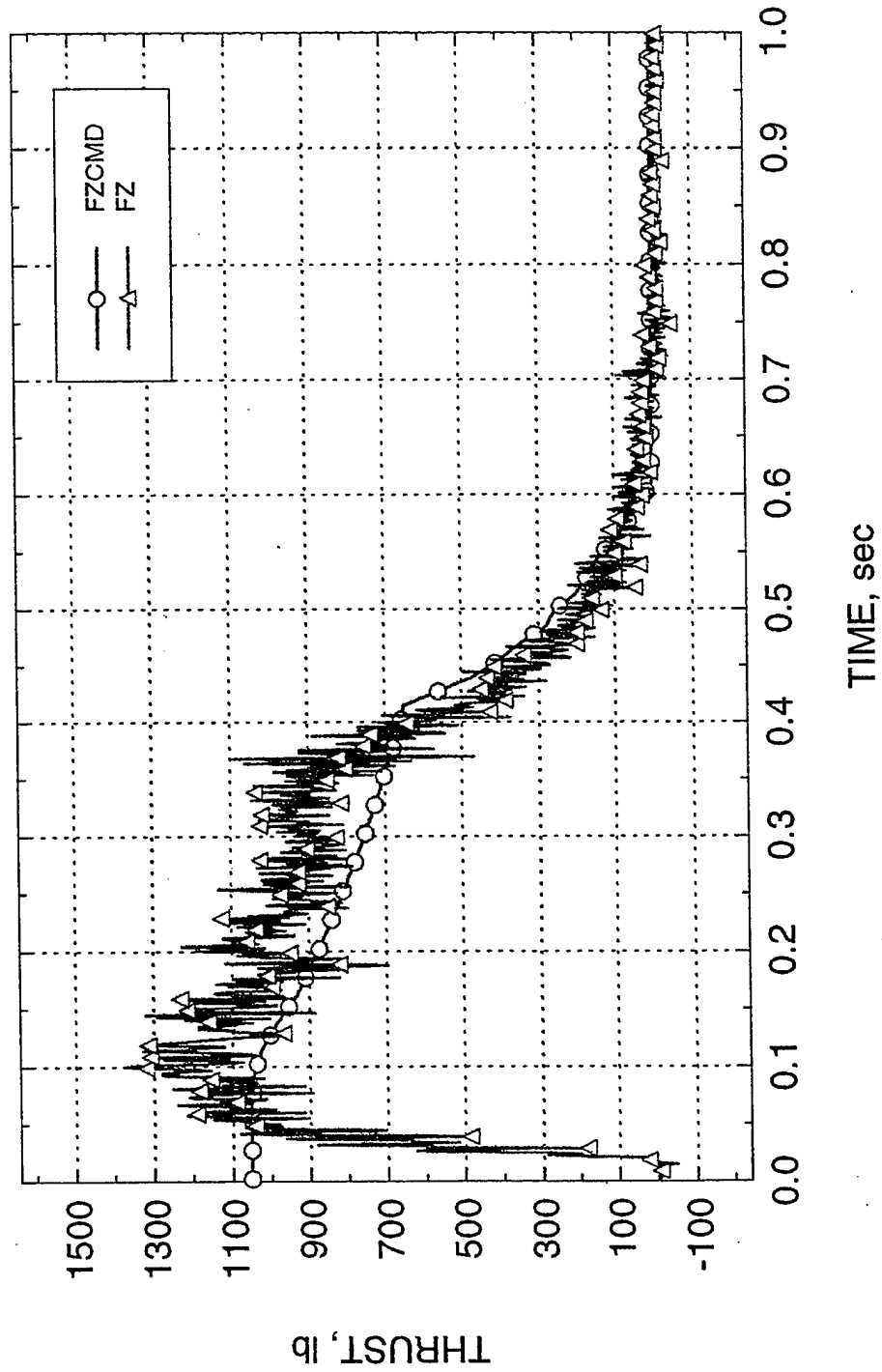



**GENCORP
AEROJET**

MAXPAC TEST 300 RESULTS

X-AXIS MOMENT

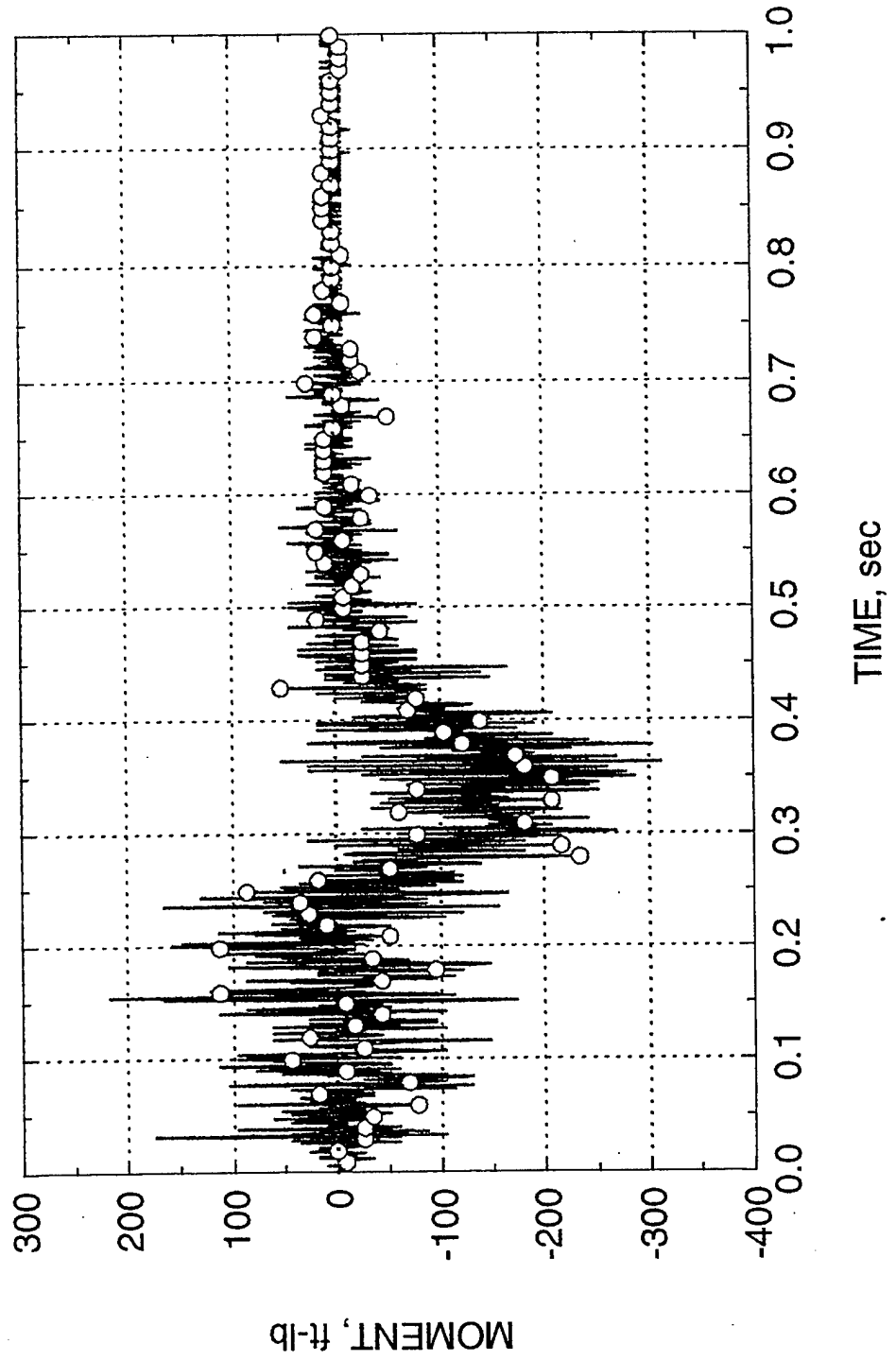



GENCORP
AEROJET

MAXPAC TEST 300 RESULTS

Y-AXIS MOMENT

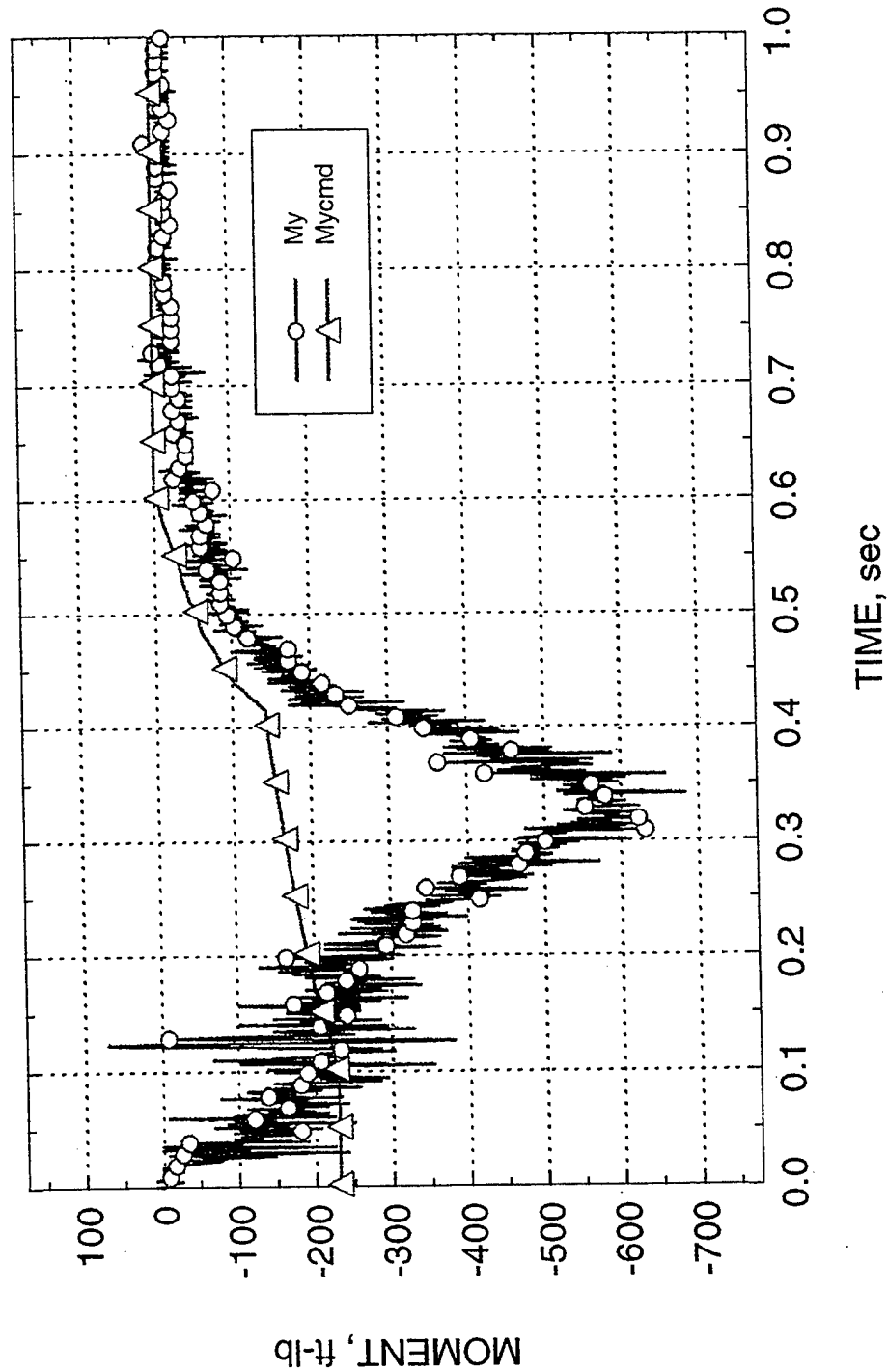



MAXPAC TEST 300 RESULTS

GENCORP
AEROJET

Z-AXIS MOMENT

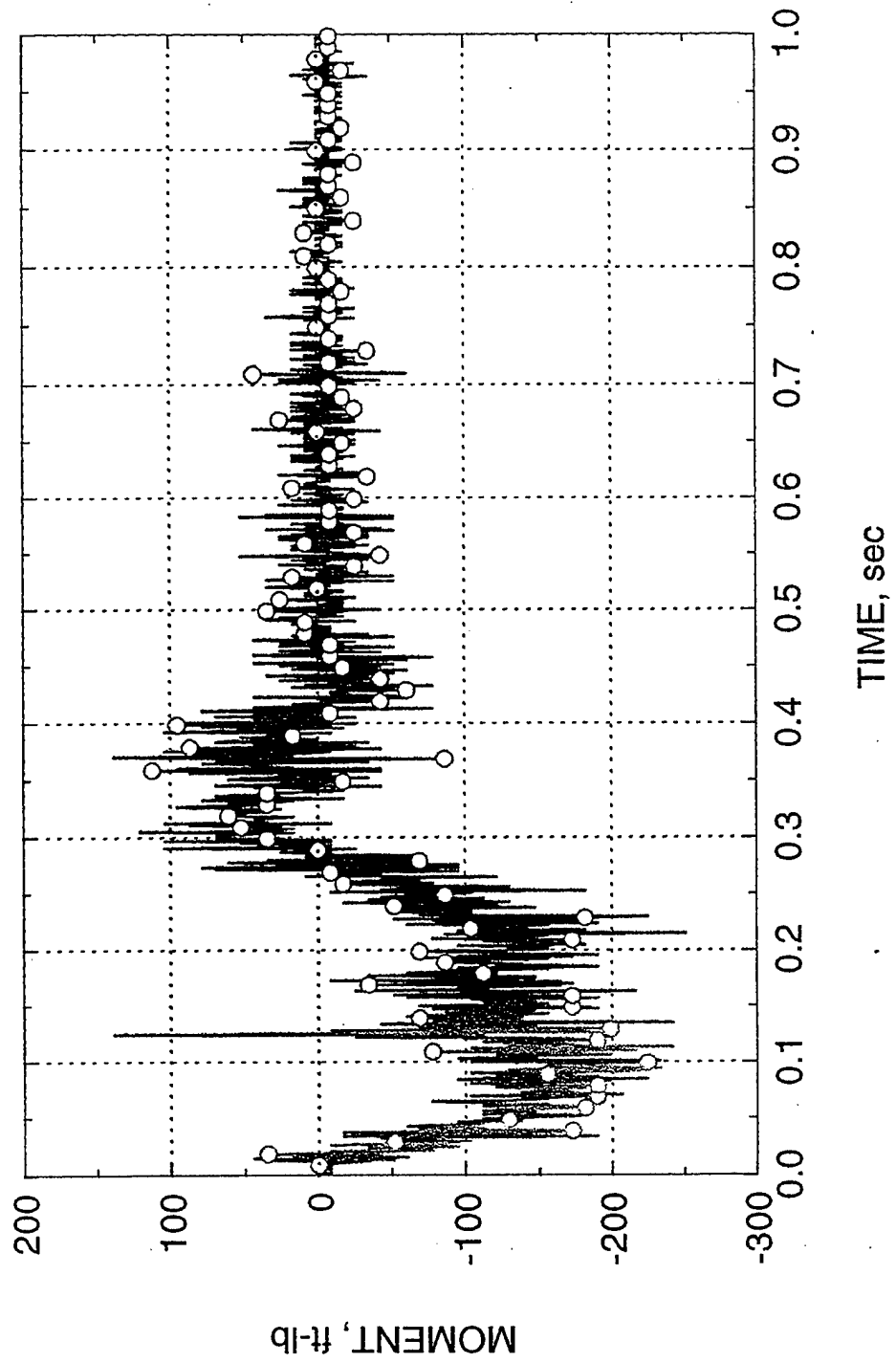



MAXPAC TEST 300 RESULTS

GENCORP
AEROJET

Nozzle 1 Thrust

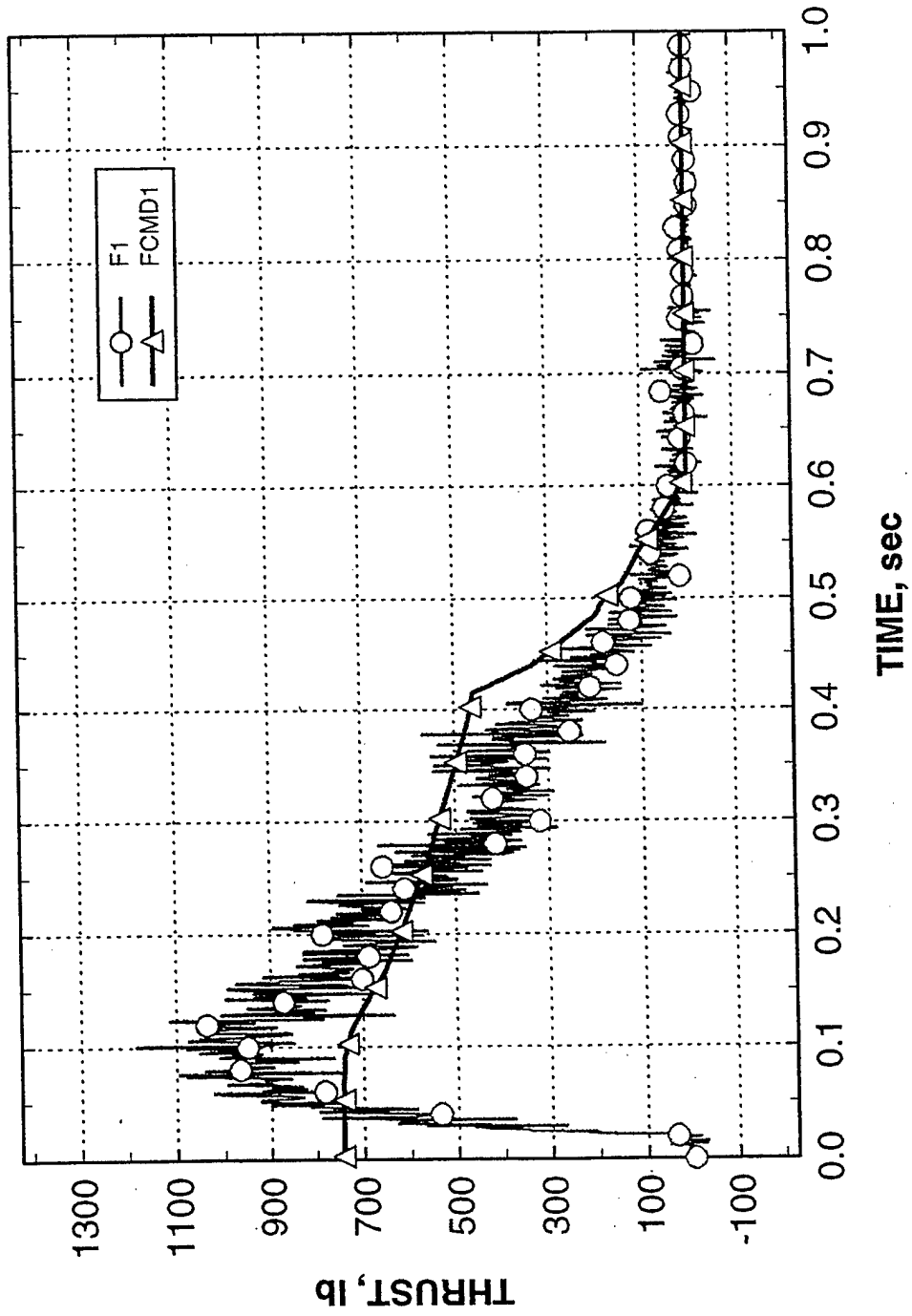



GENCORP
AEROJET

MAXPAC TEST 300 RESULTS

Nozzle 2 Thrust

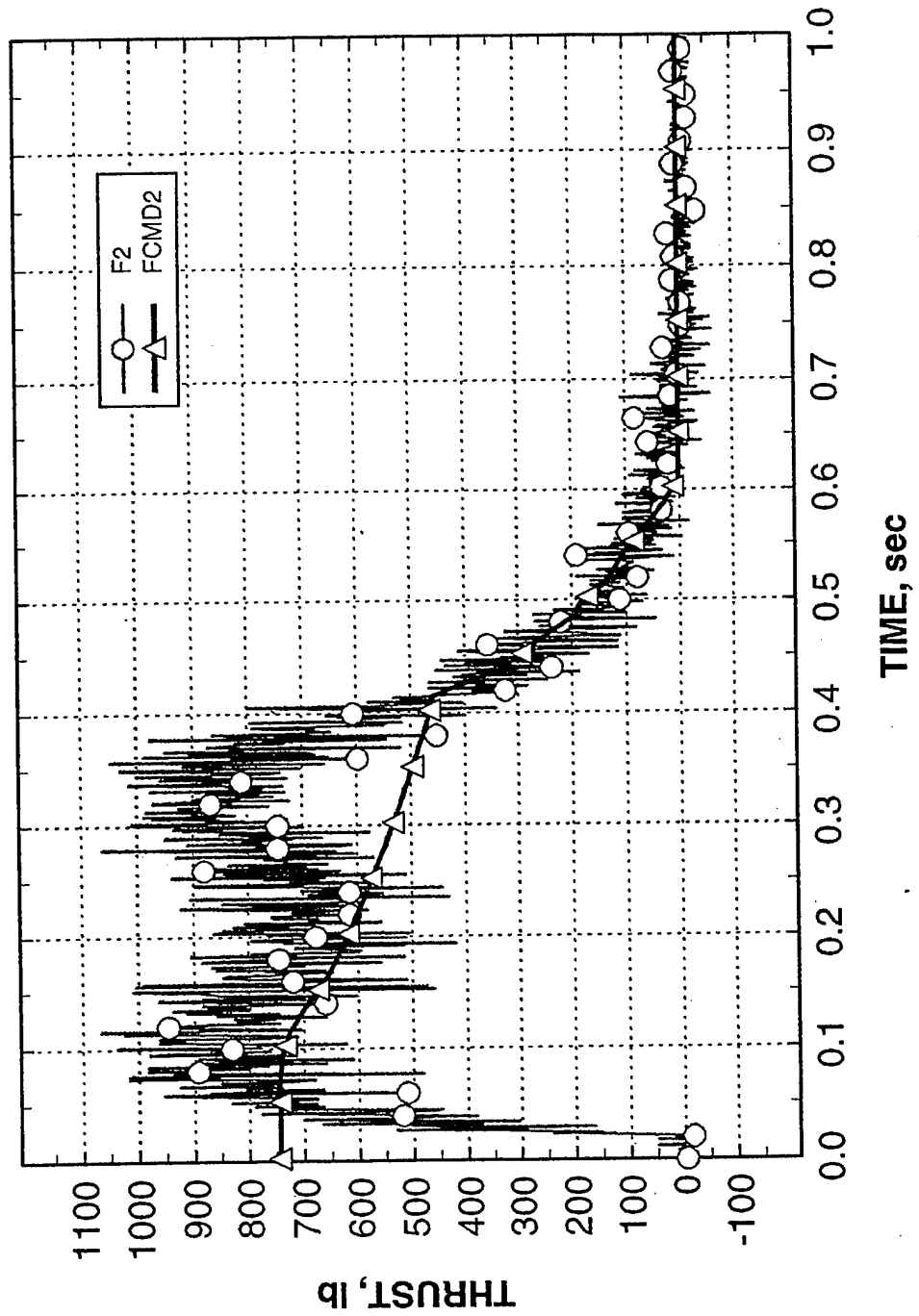



GENCORP
AEROJET

MAXPAC TEST 300 RESULTS

Nozzle 3 Thrust

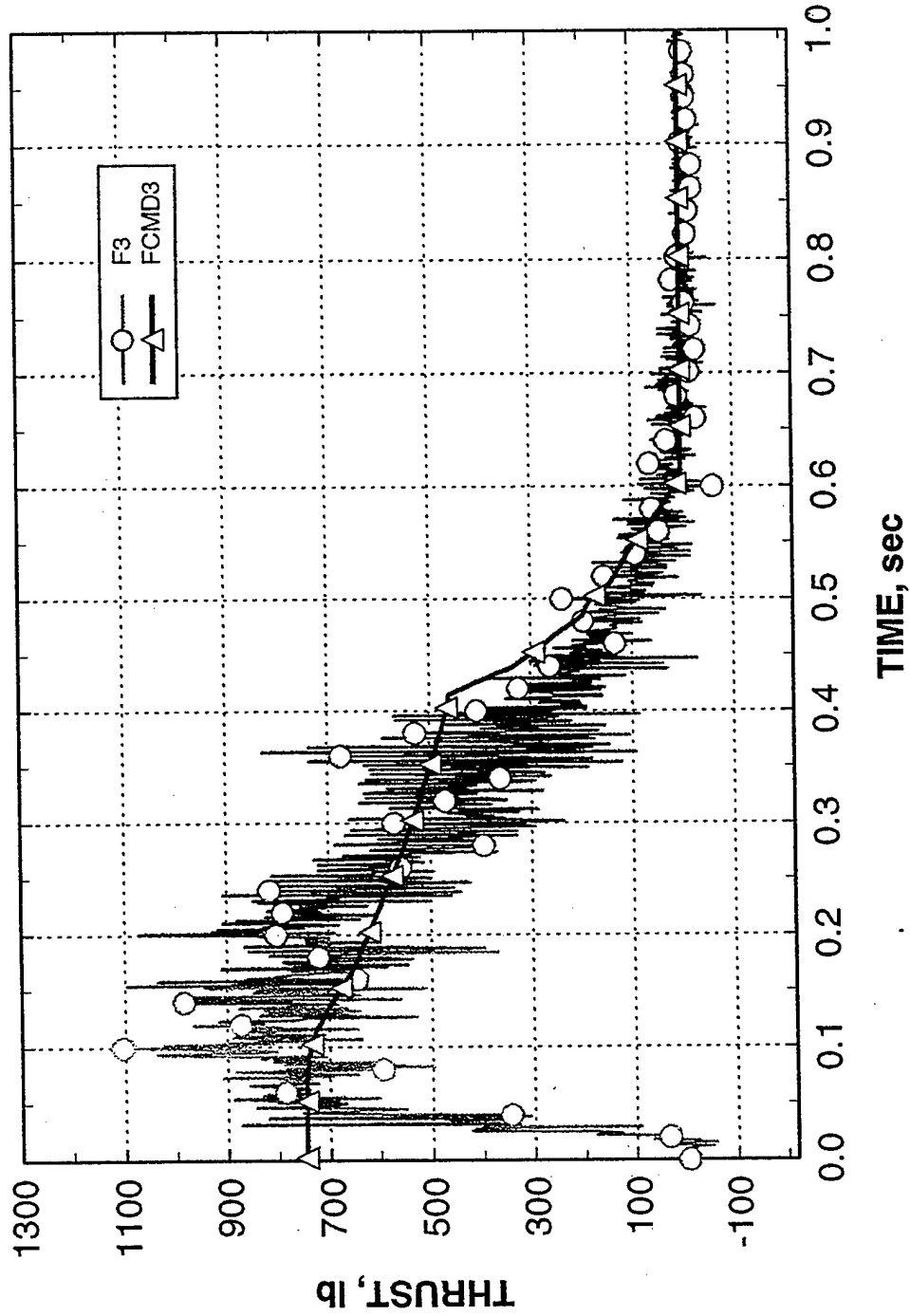



MAXPAC TEST 300 RESULTS

**GENCORP
AEROJET**

Nozzle 4 Thrust

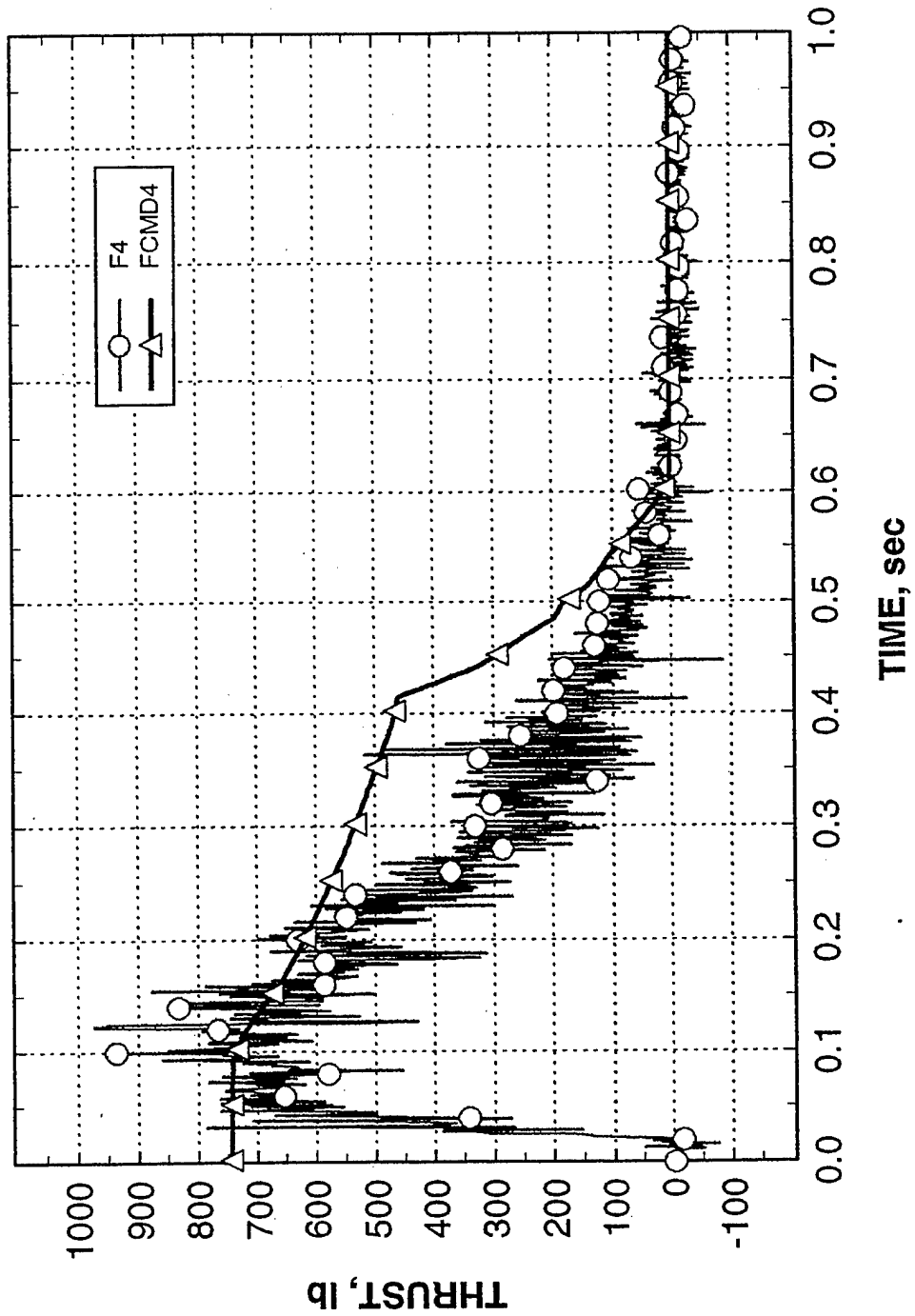



CONCLUSIONS & RECOMMENDATIONS

● CONCLUSIONS

- ✦ ALL PROGRAM OBJECTIVES WERE ACHIEVED
- ✦ SOME HARDWARE MODIFICATIONS WERE NECESSARY TO ACCOMPLISH MOTOR TESTING
- ✦ NEAR TERM CASE JOINT FIX WORKED AS PLANNED
- ✦ KISTLER FORCE MEASURING TABLE PERFORMED AS DESIRED
- ✦ TEST 2 & 3 PROVIDED CRITICAL DATA ILLUSTRATING THAT THE MAXPAC ROCKET MOTOR DOES PROVIDE THE THRUST LEVELS AND RESPONSE TIMES NECESSARY

● RECOMMENDATIONS

- ✦ REDESIGN CASE JOINT AND HYDROTEST
- ✦ CONDUCT COMPONENT MATERIAL SWAPOUT TESTS RE: WEIGHT REDUCTION
- ✦ CONDUCT 4 OR 5 GROUND TESTS DEMONSTRATING SYSTEM INTEGRATION, (ROCKET MOTOR, EPAC AND SEAT)
- ✦ PREPARE FOR SLED TESTING IN SUMMER OF '97