

AU/ACSC/028/2000-04

AIR COMMAND AND STAFF COLLEGE

AIR UNIVERSITY

DEPUTY OPERATIONS GROUP COMMANDER FOR
MAINTENANCE -- DOGM

“BANDAID OR SOLUTION?”

by

Clifton D. Blanks, Major, USAF

A Research Report Submitted to the Faculty

In Partial Fulfillment of the Graduation Requirements

Advisor: Lieutenant Colonel Steven O. Purtle

Maxwell Air Force Base, Alabama

April 2000

DISTRIBUTION STATEMENT A
Approved for Public Release
Distribution Unlimited

20010924 070

DISTRIBUTION A:

Approved for public release; distribution is unlimited.

Air Command and Staff College
Maxwell AFB, Al 36112

Disclaimer

The views expressed in this academic research paper are those of the author and does not reflect the official policy or position of the US government or the Department of Defense. In accordance with Air Force Instruction 51-303, it is not copyrighted, but is the property of the United States government.

Contents

	<i>Page</i>
DISCLAIMER	ii
ILLUSTRATIONS	v
TABLES	vi
PREFACE	vii
ABSTRACT.....	viii
INTRODUCTION	1
The DOGM Concept	1
Conceptual Framework.....	2
BACKGROUND	4
Maintenance Prior To Reorganization.....	4
The Objective Wing.....	6
Additional Factors	8
Talk of Realignment	9
The Birth of the DOGM	10
Continuing Debate.....	11
MAIN BODY.....	13
The Survey.....	13
Development.....	13
Population and Sample Size	14
Return Rates	15
Position	15
Operations.....	15
Maintenance.....	15
Overall	15
Analysis of Survey Responses.....	16
Satisfaction and the Likert Scale	16
Average.....	16
Major Focus Areas.....	17
Benefits.....	18
Problems	19

Clearly Understood Responsibilities	20
Necessary Authority	21
Chain of Command Issues	22
Personality Dependent	23
Factors Influencing DOGM Success	24
Recommended Changes	25
CONCLUSIONS.....	29
Satisfaction	29
Recommended Changes	31
More Clearly Define DOGM Responsibilities	31
Give the DOGM More Authority	32
Senior Leader Perspective	33
Closing Remarks.....	34
DEPUTY OPERATIONS GROUP COMMANDER FOR MAINTENANCE (DOGM)	
SURVEY.....	37
GLOSSARY	40
BIBLIOGRAPHY.....	41

Illustrations

	<i>Page</i>
Figure 1. Maintenance Prior To Reorganization.....	5
Figure 2 Objective Wing Maintenance Organization	7

Tables

	<i>Page</i>
Table 1 - Survey Return Data	15
Table 2 - Satisfaction Ratings	16
Table 3 - Responses to Recommended Changes Question	26

Preface

I am a career USAF aircraft maintainer who has spent many years on the flight line—both before and after reorganization to the objective wing structure. I am not a “hardliner” who feels that the only true maintenance system is one led by a Deputy Commander for Maintenance (DCM). I can see some utility in both organizational constructs. The genesis for this research project was my fascination with the Deputy Operations Group Commander for Maintenance (DOGM) and how differently the interactions in the Operations Group (OG) could be based on the personalities of both the DOGM and the OG commander. I did not begin this project with a specific thesis that I was trying to prove. I was curious to discover the experiences of the rest of the Air Force and find out if they were satisfied with the DOGM concept.

I received considerable help from many talented people, both at ACSC and out in the field. Encouragement from my research advisor to focus on the critical aspects of the project early in the academic year kept me on track. I could not have completed the project without the help of Maj Mack Breeland, project officer at ACC when the DOGM concept was fielded. However, the biggest thanks go out to all of those in the field who took time during their busy days to complete the survey with candid responses.

This research project does not identify the “final solution” but should be viewed as the first step to improving DOGM effectiveness. What remains is for our functional experts at HQ AF or the Major Commands (MAJCOMs) to evaluate the possibilities and make an informed decision on the future of the DOGM concept.

Abstract

There is considerable debate across the Air Force on the best way to functionally organize flight line aircraft maintenance. The latest organizational iteration has placed a lieutenant colonel aircraft maintainer in the Operations Group as the Deputy Operations Group Commander for Maintenance (DOGM). The purpose of this research is to determine the unit (base) level satisfaction with the DOGM concept and to capture suggestions from the field to improve the DOGM's effectiveness. With no formal research on this new duty position, the primary instrument for data collection was a survey drafted by the research author and sent to senior operations and maintenance leaders at fourteen bases in Air Combat Command, United States Air Forces in Europe, and Air Education and Training Command. Satisfaction results showed an overall rating just above neutral as measured using a five-point Likert scale. Survey comments indicated a perceived lack of clearly defined responsibilities in the maintenance instructions and insufficient authority vested in the position were the most important factors detracting from DOGM effectiveness. There were a number of recommendations from survey respondents aimed at improving the position's effectiveness. Some were as simple as including DOGM responsibilities in 21-101 maintenance series instructions. Other suggestions involved significant structural changes to the objective wing organization to increase the formal authority of the DOGM. The paper concludes with some general recommendations based on survey results.

Part 1

Introduction

“Just say ‘No’ to Ops,”¹ was a phrase coined by a flight line maintenance officer in 1989 to try to build pride within his aircraft maintenance unit (AMU). The message, only partially tongue in cheek, was that AMU leadership was not going to allow “Operations” to drive up sortie rates without proper regard for the impact on “Maintenance.” Imagine their chagrin two years later with the advent of the objective wing when ownership of flight line maintenance was moved to the Operations Group. Many maintainers considered this change tantamount to “letting the fox loose in the hen house.”

The DOGM Concept

Since 1991, the objective wing structure has evolved while adapting to changes brought on by military draw down. The latest organizational iteration of the objective wing places a senior level maintenance manager in the Operations Group -- the Deputy Operations Group Commander for Maintenance, or DOGM. His charge is to “provide support, technical expertise and increase maintenance manpower to the Ops Group Commander.”² Little other defining guidance was given to the field, and there are currently no Air Force (AF) or Major Command (MAJCOM) maintenance instructions that specifically delineate the responsibilities of the DOGM.

Despite the fact that the objective wing structure has been in place for several years, there is still considerable discussion across the AF about the best way to functionally organize flight line maintenance. Although the DOGM positions have been fielded for three years now, there have been no formal studies on its effectiveness and very little written about the overall satisfaction with the concept. This lack of information on what many still consider to be a fairly contentious subject was the genesis for this research effort. The intent is not to add fuel to the “bring back the Deputy Commander for Maintenance” fire. The focus is much narrower. The goals are to gain some insight on field level satisfaction with the DOGM concept and to identify potential changes that could make the position more effective. These goals led to the following research questions:

1. To what extent are field level operations and maintenance leaders satisfied with the effectiveness of the DOGM?
2. What types of changes can be made to the current concept to make it more effective?

Conceptual Framework

The conceptual framework for the paper is straightforward. Part Two is a discussion of background information with a focus on the factors leading to the creation of the DOGM. It will not be an in-depth discussion of maintenance organization. However, it would be impossible to discuss the issues facing the DOGM and aircraft maintenance today without reviewing some of the essentials of maintenance organization prior to the objective wing and follow its evolution over the past eight years. This section will set the stage for subsequent discussions.

The major instrument for data collection for this project was a detailed survey sent out to selected operations and maintenance leaders in fighter wings across much of the AF. Part Three is an explanation of the survey to include a discussion of survey development, population and

sample size, and an analysis of the results in each of the major topical areas. I'll conclude in Part Four with a brief review of the findings and analysis of the survey results, tie them back to the research questions, and offer a recommendation on what, if anything, should be done to improve DOGM effectiveness.

Notes

¹ Major James Ayers, OIC, 309 AMU. September 1989. Homestead Air Force Base, Florida.

² Message. 020700Z APR 96. US Air Force. From PACAF LG to command OG and LG CCs. 2 April 1996.

Part 2

Background

In the beginning there was the Chief of Maintenance who ruled the kingdom known as the maintenance complex. For the subjects, the maintenance complex was more than a place--it was a state of mind.

— Lieutenant Colonel James D. Pauley, Jr., USAF
Air Force Journal of Logistics

Lieutenant Colonel Pauley's statement captures much of the mystique that surrounded the Chief of Maintenance, or Deputy Commander for Maintenance (DCM) as the position had come to be known, prior to the reorganization to the objective wing structure. In a short conversation, the DCM might be referred to with admiration, reverence, or fear--but always with a certain measure of respect. They stood for much more than just quality maintenance. Aircraft maintainers saw the DCM as the one standing behind them who would ultimately "draw the line in the sand" if Operations, or anyone else, tried to do something that would adversely affect aircraft maintenance.

Maintenance Prior To Reorganization

The wing organizational structure prior to reorganization had three deputy commanders--one each for Maintenance, Operations, and Resource Management. The flying squadrons and operations support functions were assigned under the Deputy Commander for Operations (DCO)

while aircraft and the maintenance personnel were aligned under the DCM. The typical aircraft maintenance complex had a Component Repair Squadron (CRS), an Equipment Maintenance Squadron (EMS), and an Aircraft Generation Squadron (AGS). The flight line maintainers were assigned to the AGS in aircraft maintenance units (AMUs).

Each AMU was responsible for the aircraft maintenance for a specified flying squadron. These personnel were not assigned to the fighter squadrons per se, but functioned as a matrixed organization with the common goal of combat readiness. According to Air Force Regulation (AFR) 66-5, Production Oriented Maintenance Organization, an AMU was a “semiautonomous production element that has the responsibility for the launch, service, on equipment repair, and recovery of primary assigned aircraft.”¹ A typical AFR 66-5 maintenance organization can be seen in Figure 1 below.

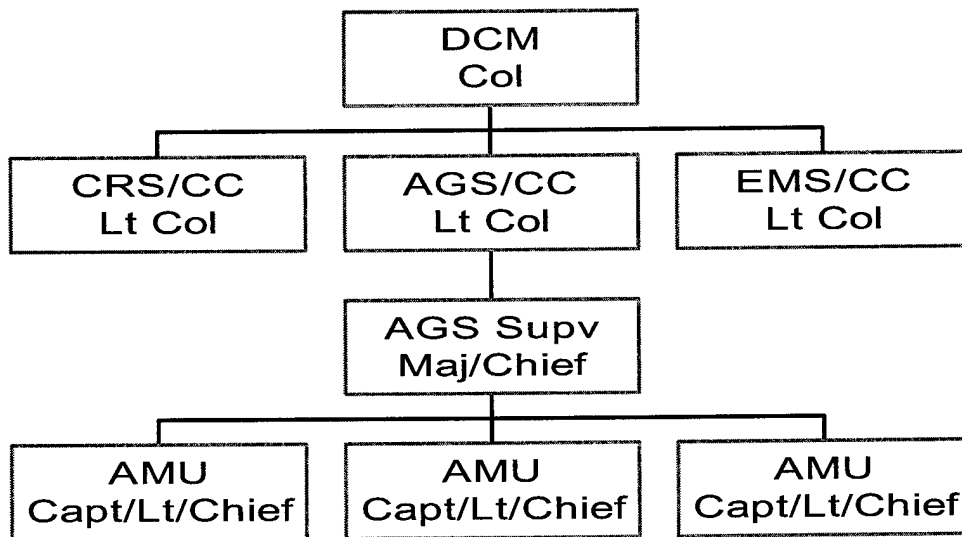

Figure 1. Maintenance Prior To Reorganization²

Again referring to AFR 66-5, the DCM was responsible for “management of the entire maintenance complex” and his authority was delegated directly from the wing commander. More specifically, he was to ensure that the maintenance performed was “timely and of high

quality.” The AGS commander was charged with giving “direction and guidance for the effective operation of the unit maintenance effort.” This was exercised through the AGS Maintenance Supervisor who managed the assigned resources to accomplish the maintenance and was responsible to the commander for the “technical supervision and maintenance production of the squadron.” Management of specific maintenance functions was delegated to the AMU Chief.³ The AMUs were “semiautonomous” as prescribed in the regulation, but served under the maintenance umbrella of the DCM.

The Objective Wing

In 1990, Chief of Staff of the Air Force (CSAF) General Merrill McPeak directed tactical fighter wings to become “more responsive to the operational warfighting mission and also achieve some economies of scale in manpower savings and organizational efficiencies.”⁴ The 347th Fighter Wing was selected as the test base for one form of realignment and was tasked to develop a plan that allowed for the “disestablishment of the Aircraft Generation Squadron, significant manpower savings in the maintenance complex, and increased efficiency and scale of operations in an operational theater.”⁵ Their efforts were the genesis for the organizational structure that we operate under today. (See Figure 2)

Under the Objective Wing, the Tri-deputy system was disassembled and aircraft maintenance was split between the Operations Group (OG) and the Logistics Group (LG). The LG became responsible for the off-equipment aircraft maintenance, inheriting the EMS and CRS. The OG became the owner of the aircraft themselves, and significant portions of the AGS, to include the AMUs. Many of the old DCM responsibilities from AFR 66-5 were now applicable to both the LG and the OG. Specifically, both commanders became responsible for ensuring

high quality aircraft maintenance was performed in a timely manner, and that maintenance capabilities were considered in the development of the flying program.⁶

Flight line maintainers who previously resided in AMUs were now assigned to flying squadrons themselves. The flying squadron commander became responsible for maintenance on his assigned aircraft. This alignment was consistent with the organizational structure of a flying squadron deployed to an operational theater with the “on-scene commander responsible for all maintenance personnel and all assigned maintenance actions.”⁷ Officers from AMUs moved to become Officers-In-Charge of Sortie Generation and Sortie Support Flights. AGS Supervision was gone, but a field grade maintenance position, the Squadron Maintenance Officer (SMO), was added to flying squadrons as the organizational equivalent of the operations officer. The SMO is “responsible to the squadron commander for maintenance production” and manages the maintenance resources necessary to accomplish the mission.⁸

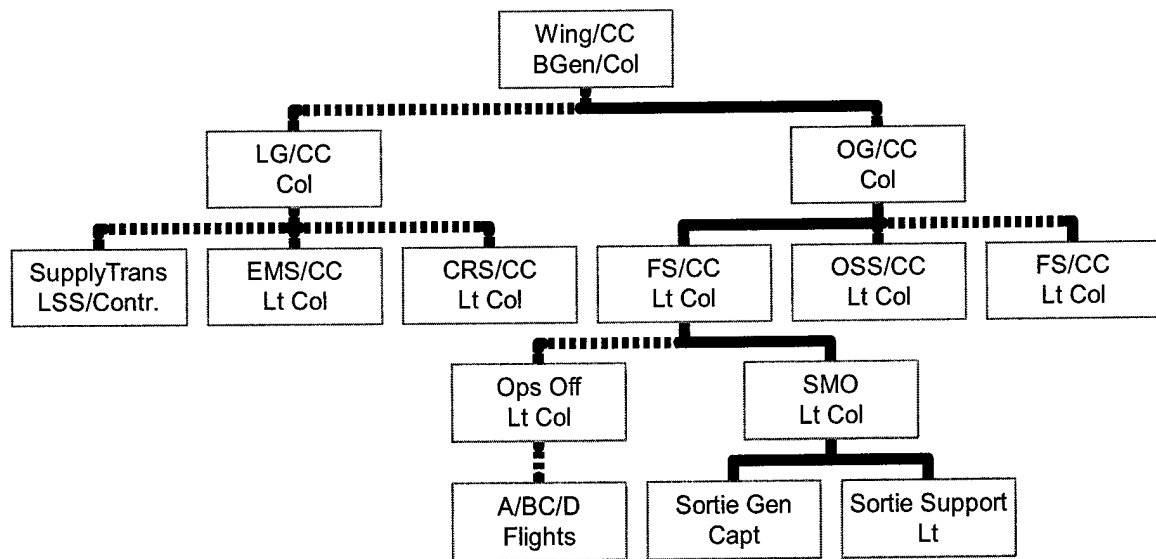

Figure 2 Objective Wing Maintenance Organization

(Solid line represents new flight line maintenance chain of command.)

There were those who believed, like General McPeak, reorganizing to train the way we deploy and fight would increase combat capability and unit cohesion.⁹ Many aircraft maintainers became concerned that without a DCM maintenance priorities and training could be sacrificed with the pressure to fly sorties day-to-day. They argued that the new organization would lead to “reduced combat capability (ability to generate)” and “increased safety of flight problems.”¹⁰

Additional Factors

There were several other dynamics that affected aircraft maintenance at the time. The movement away from compliance-type inspections and some realities of the SMO position had an impact on aircraft maintenance and ultimately helped set the stage for the implementation of the DOGM. Gone were the days of the Maintenance Standardization and Evaluation Team (MSET) or Maintenance Standardization and Assistance Team (MSAT) visits to help validate the strengths and weaknesses of unit level maintenance. Also, Inspector General (IG) teams were moving away from Unit Effectiveness Inspections (UEIs) to Quality Air Force Assessments (QAFAs). This paper is not the place to discuss the Air Force quality movement, but suffice to say there was less emphasis on compliance-type inspections at about the same time the DCM position was abolished and much of the flight line maintenance supervisory structure was significantly changed.

As previously mentioned, the SMO position was created to be “organizationally equivalent” to the flying squadron operations officer.¹¹ Although the original manning billets called for lieutenant colonels, they proved to be very hard to fill for several reasons. First, lieutenant colonel maintenance officer manning was approximately 60 percent in the early 1990s. After filling priority headquarters staff positions and squadron commander openings, there were not

enough lieutenant colonels left to fill all SMO positions. Second, many lieutenant colonels felt that becoming a SMO was a backwards step, especially those who had already been squadron commanders.¹² This was because many viewed the SMO positions as the organizational equivalent of the AMU OICs under the previous system.

After the Objective Wing test in the 347th Tactical Fighter Wing, Col Paul Dilling, the LG remarked, "I argue that one of the toughest jobs a maintenance officer will fulfill is that of the flying squadron maintenance officer. He will be the best that you have..."¹³ However, the reality was that many of our best lieutenant colonels were staying away and that most of the SMO positions were being filled by majors and in some cases captains.¹⁴ Many could argue that "organizational equivalence" with the flying squadron operations officer was never achieved.

Talk of Realignment

In the years following reorganization, there has been a growing unrest in the maintenance community. In addition to the decline in compliance-type inspections and the problems with manning the SMO positions, there were growing concerns over declining mission capable (MC) rates across the fleet and the limited maintenance experience of most OGs and flying squadron commanders.¹⁵ Although no one was blaming the declining MC rates solely on the reorganization, it was one of the issues that helped fuel the talk of returning to the AGS and DCM concept. Work on realignment packages began at several MAJCOMs.

Since General McPeak was the catalyst for the Objective Wing, he would not allow any major changes under his reign¹⁶. However, once General Fogelman moved from Commander of Air Mobility Command (AMC) to his new position as CSAF, he allowed AMC to realign flight line maintenance back to an AGS concept, but under the LG. When other MAJCOMs began submitting packages advocating similar realignments, the word came from HQ AF that General

Fogelman wanted a consolidated position on this issue across the combat air forces (CAF). For the realignment plan to be approved, the 4-Stars from Air Combat Command (ACC), United States Air Forces in Europe (USAFE), Pacific Air Forces (PACAF), and Air Education and Training Command (AETC) all had to agree on the concept. As the action officer from ACC remarked, "I'll tell you, it's not easy to the 4-Stars to agree."¹⁷ And they never did.

The Birth of the DOGM

With hopes for realignment fading, the focus turned to an alternative--the DOGM. Several bases had already assigned field grade maintenance officers to the Operations Group, many in the Operations Support Squadron (OSS) as the Deputy, or Operations Officer. After coordination between the MAJCOMs, the decision was made to add a second Operations Group deputy and the concept was approved by the CSAF.

In a message to the field stating his position on the newly created DOGM position, the ACC Commander (COMACC) stated:

Creating a second Ops Group deputy with a strong maintenance background will bring essential balance to the Ops Group and provide the commander with a clear focus on fleet health issues, maintenance training, and daily integration of the maintenance effort. The creation of this new deputy position is not intended in any way to alter Ops squadron responsibilities for managing basic maintenance planning, production, and training. It is designed to enhance the Ops Group Commander's ability to execute his ultimate responsibility of providing clear guidance and oversight for organizational maintenance and the wing flying operation.¹⁸

A PACAF/LG message on the DOGM position contained similar guidance. Additionally, it included a list of proposed responsibilities that were later incorporated into command level maintenance instructions but were removed approximately one year later. The responsibilities included attending the daily maintenance scheduling meeting, developing local procedures for things such as supply and red ball maintenance, facilitating resolution of conflicting maintenance

requirements with flying squadron commanders, periodically reviewing limiting factors and shortfalls of mobility simulation requests, developing procedures for the wing depot-level assistance program, and managing the end-of-runway and joint oil analysis programs.¹⁹

There were indications in some message traffic and in the rationale provided for the Organization Change Request that the addition of the DOGM could enhance maintenance discipline and standardization and provide "improved oversight and functional guidance of flight line maintenance activities."²⁰ However, that philosophy never made it into the maintenance instructions, even during the short time specific DOGM responsibilities were included. The rationale given for not including specific guidance was that responsibilities were not broken out for other deputy positions and therefore wouldn't be for the DOGM. It would be up to the respective OGs to delegate responsibilities as they see fit.²¹

Continuing Debate

The debate over appropriate organization and control of flight line maintenance continues across much of the Air Force today. Recent realignment proposals from several MAJCOMs have caused stirrings that have many believing there may be significant changes on the horizon. A USAFE Maintenance Organizational Structure Assessment led to a proposal that was sent to the CSAF in September 1999. As a result, the CSAF directed his staff to conduct a review of logistics processes and report back to him by September 2000²² This review could cause significant changes to the DOGM position or its elimination if there is a return to the DCM concept. However, preliminary indications from the staff are that our current CSAF, General Ryan, does not favor major changes to the existing organizational structure.²³ Therefore, it appears as though the DOGM, or a position quite similar, may be with us for awhile.

Notes

- ¹ Air Force Regulation (AFR) 66-5. *Production Oriented Maintenance Organization*. 15 July 1979, page 9-1, paragraph 9-1.
- ² Based on the organizational structure outlined in Chapters Two and Nine in AFR 66-5.
- ³ Air Force Regulation (AFR) 66-5. *Production Oriented Maintenance Organization*. 15 July 1979, pgs 1-4 to 1-5, paragraph 1-17.
- ⁴ Michels, Maj Joseph B. "Tactical Fighter Wing Reorganization: The Implications for the Maintenance Officer." *Air Force Journal of Logistics*. Vol XVI, No. 2, page 21.
- ⁵ Ibid, page 21.
- ⁶ Air Combat Command Instruction (ACCI) 21-101. *Objective Wing Aircraft Maintenance*. 2 October 1998, page 38, paragraphs 2.3.1 and 2.3.3.
- ⁷ Michels, Maj Joseph B. "Tactical Fighter Wing Reorganization: The Implications for the Maintenance Officer." *Air Force Journal of Logistics*. Vol XVI, No. 2, page 22.
- ⁸ Air Combat Command Instruction (ACCI) 21-101. *Objective Wing Aircraft Maintenance*. 2 October 1998, page 42, paragraph 2.6.
- ⁹ Rine, Maj Joseph R., Jr. "The Maintenance Officer Role in the Objective Wing Organization." *Air Force Journal of Logistics*. Vol XVI, No. 2, page 24.
- ¹⁰ Ibid, page 24.
- ¹¹ Michels, Maj Joseph B. "Tactical Fighter Wing Reorganization: The Implications for the Maintenance Officer." *Air Force Journal of Logistics*. Vol XVI, No. 2, page 22.
- ¹² Electronic mail correspondence from Maj Mack Breeland former staff officer Maintenance Policies and Procedures Branch HQ ACC. 7 November 1999.
- ¹³ Michels, Maj Joseph B. "Tactical Fighter Wing Reorganization: The Implications for the Maintenance Officer." *Air Force Journal of Logistics*. Vol XVI, No. 2, page 22.
- ¹⁴ Electronic mail correspondence from Maj Mack Breeland former staff officer Maintenance Policies and Procedures Branch HQ ACC. 7 November 1999.
- ¹⁵ Ibid.
- ¹⁶ Ibid.
- ¹⁷ Ibid.
- ¹⁸ Message. 071421Z MAR 97. US Air Force. From COMACC to subordinate wings. 7 March 1997.
- ¹⁹ Message. 020700Z APR 96. US Air Force. From PACAF LG to command OG and LG CCs. 2 April 1996.
- ²⁰ Goddard, Maj Gen Richard N., ACC Director of Logistics. Memorandum. To HQ ACC/XP. Subject: Organizational Change Request, 29 December 1995.
- ²¹ Electronic mail correspondence from Maj Mack Breeland former staff officer Maintenance Policies and Procedures Branch HQ ACC. 7 November 1999.
- ²² Message. 041638Z JAN 00. US Air Force. From USAFE CC to subordinate wings. 4 January 2000.
- ²³ Electronic mail correspondence from Chief Fred McGregor, Maintenance Policies and Procedures Branch, HQ ACC. 17 March 2000.

Part 3

Main Body

We have worked the DOGM's responsibility at the OG level and even find ourselves at odds with wing leadership (through inputs from the LG who is at odds with the concept) and cannot use MAJCOM guidance to justify our position.

— Survey Respondent #120

With so little written on a concept that is just three years old, the only way to capture the type of candid opinion expressed by the senior operations group leader in the quotation above is through the use of an anonymous field survey. The initial part of this section is devoted to how the survey was developed, a look at the target population and sample size, and a discussion of return rates. Subsequently, each of the major topical areas will be addressed individually and in greater detail.

The Survey

Development

The survey was drafted by the research project author with the assistance of several career aircraft maintainers attending Air Command and Staff College in residence during Academic Year 2000. After a limited pilot test to validate the survey, it was submitted and approved by HQ AF in early December 1999. The author recognizes and accepts a certain fighter aircraft bias in the survey. His background is exclusively fighter maintenance and that certainly affected survey

development. However, as previously documented, since AMC realigned back to an AGS concept under the LG, the DOGM issue is predominantly, though not exclusively, a fighter aircraft issue. The approved survey was submitted to bases in ACC, AETC, and USAFE in early December 1999. (Survey questionnaire at Appendix A)

Population and Sample Size

There are fifty-two active duty fighter squadrons in ACC, PACAF, and USAFE assigned at nineteen different bases, and eleven fighter squadrons assigned at two bases in AETC.¹ The survey was designed to be administered to OGs, LGs, DOGMs, fighter squadron commanders, SMOs, and fighter squadron superintendents (Chief Master Sergeants.) With sixty-three fighter squadrons at twenty-one bases and the targeted positions listed above, the overall survey population is approximately 250 personnel. Of note, surveys were accepted, but not actively solicited, from individuals who had previously served in one of the targeted positions since the inception of the DOGM. Their inputs are just as valid for content, but make it very difficult to determine the exact population of the survey.

Surveys were distributed through single points of contact, typically the DOGM, at 14 bases in ACC, USAFE, and AETC. Time and distance created communication difficulties that resulted in no surveys being distributed to bases in PACAF. This led to an approximate sample size of 180, almost 75 percent of the target population. In addition to the surveys being filled out by personnel not currently holding one of the listed positions, it was impossible to determine how many personnel were TDY or on leave when the surveys were administered at their bases. Therefore, it was not possible to determine exact numbers for sample size and return rates. Approximations in these cases will not detract from the usefulness of the survey.

Return Rates

A total of seventy-six surveys were returned, seventy-five of those scoreable in most categories. Accounting for a sample size in excess of 180 personnel, the return rate for the survey was approximately 40 percent. A breakdown of the surveys returned, by position, is shown in Table 1.

Table 1 - Survey Return Data

Position	Surveys Returned		
OG	7		
LG	7	Operations	19
DOGM	11	Maintenance	57
FS/CC	12	Overall	76
SMO	22		
Chief	17		

Source: Compilation of returned surveys.

There were noticeably more surveys returned for those with maintenance backgrounds (LGs, DOGMs, SMOs, and Chiefs). To some degree this is to be expected since approximately two-thirds of the target population have maintenance backgrounds. However, the data indicates that 75 percent of the survey questionnaires returned were from maintainers as opposed to 66 percent had the return rates been equal across the field. There are several possible reasons for this modest disparity. First, when queried, many wings indicated that a disproportionate number of fighter squadron commanders (FS CCs) were deployed. Second, as many of the comments on the surveys highlighted, this is much more of a passionate issue for aircraft maintainers.²

There will be little formal statistical analysis of the survey data. Most questions were designed to lead to opinions, not to generate responses that could be rigorously tabulated. As such, the author is satisfied with the number of surveys returned and will take into account any bias created by having proportionately more surveys from maintenance than from operations.

Analysis of Survey Responses

The sections that follow address each of the major issues included in the survey questions. With only two exceptions the questions will be dealt with in the order in which they appeared in the survey. Question 3 on satisfaction will be addressed first, and Question 4 on recommended changes will be analyzed last.

Satisfaction and the Likert Scale

3. What is your overall satisfaction with what adding the DOGM has done for wing level aircraft maintenance?

Extremely Dissatisfied	Dissatisfied	Neutral	Satisfied	Extremely Satisfied
1	2	3	4	5

Field level satisfaction with the DOGM concept was measured using an intensity question and a five-point Likert scale. The question was written very general in nature and was designed to be used as a rough gauge and a starting point for subsequent discussion. The number of responses for each rating are shown by position in Table 2 below.

Table 2 - Satisfaction Ratings

Position/Rating	1	2	3	4	5	Average
OG	0	0	0	4	3	4.43
LG	0	3	2	1	1	3.00
DOGM	2	2	3	3	0	2.70
FS/CC	0	1	3	2	5	4.00
SMO	1	7	3	6	4	3.24
Chief	1	8	3	5	2	3.00
Operations	0	1	3	6	8	4.17
Maintenance	4	20	11	15	7	3.05
Overall	4	21	14	20	15	3.32

Source: Compilation of returned surveys.

Table 2 shows an overall rating just above neutral at 3.32 and a noticeable disparity between Maintenance and Operations. It appears the OGs are the most satisfied with the DOGM concept. All of the OG ratings were four or five and resulted in the highest average at 4.43. Returning for a moment to verbiage in the COMACC message cited previously, the DOGM concept “is designed to enhance the Ops Group Commander’s ability to execute his ultimate responsibility of providing clear guidance and oversight for organizational maintenance and the wing flying operation.”³ If the OGs are this satisfied with what the DOGMs are doing for them, then one could argue that the concept is on target.

However, Maintenance satisfaction numbers are significantly lower. Interestingly enough, though the OGs are the most satisfied, their DOGMs are the least satisfied with the current concept. Could the lower rating from maintainers stem from a lingering resistance to aligning flight line maintenance under Operations? How much of it could be from concern over perceived deficiencies in aircraft maintenance management and what the DOGM position could be contributing and is not? The answers to these questions are difficult to determine, but analysis of the remainder of the survey questions will provide at least part of the answer.

Major Focus Areas

- 1. What are the major focus areas of the DOGM in your wing? (for example: maintenance discipline, standardization, shared resource allocation, scheduling, training, deployment oversight, reviewing unit maintenance, others)*
- 2. What SHOULD the focus areas be? (Please briefly explain the differences.)*

As previously noted, there is little regulatory guidance outlining the responsibilities of the DOGM. The first two questions on the survey had two purposes; to draw out information on what areas the DOGMs were focusing their attention and to find out if disparities existed between the DOGMs focus and where the respondents thought they should be focusing.

As you can see, there is a list of “for example” answers provided. The intent was not to necessarily focus responses in these areas alone, but to give the respondents a frame of reference from which to start. In answering these two questions, there was no limit to the number of items that could be identified.

The survey results did not support the anticipated disparity between the two questions. There were only a few cases where the answers differed significantly. There are at least three possible reasons for this result. First, there is no perceived disparity in the field between what the DOGM is doing and what people believe the DOGM should be doing. Second, lack of clear guidance on DOGM responsibilities may have made it more difficult for people to answer the question. Finally, in some cases it appeared that the design of these survey questions may have limited the breadth of response.

However, there was still interesting information to garner from the responses to these questions. The “for example” responses fell very evenly into two distinct tiers. Maintenance discipline, standardization, shared resource allocation, and reviewing unit maintenance appeared on 60 percent of the returned questionnaires. These were clearly the items that most personnel believed to be the important DOGM focus areas. Scheduling, training, and deployment oversight appeared on approximately 40 percent of the surveys. All of these items could logically be deemed as important focus areas for the DOGM.

Benefits

5. How does the DOGM benefit your organization?

“He is the voice of reason to the OG on maintenance issues, and gives the OG credibility to the maintenance community.”⁴

“In this organization, not one bit.”⁵

The quotations above are from two field grade officers from the same base. Although they represent an extreme, they are indicative of the wide range of opinion on what appears to be a straightforward question. While the satisfaction ratings outlined previously show there is not overwhelming approval of the DOGM concept, they do indicate that there is some satisfaction with what the DOGMs have added to maintenance in the Operations Group. Question 5 focused on those benefits.

The most common responses to this "open" question, one without any limited or "for example" responses, highlighted maintenance oversight and expertise and shared resource allocation as benefits attributed to the DOGM. Over 25 percent of the respondents mentioned maintenance oversight and expertise at the group level as a benefit. Unfortunately, many of those answers came with the caveat in the form of "would" or "should" and mentioned a lack of DOGM responsibility and authority. This mention of authority and responsibility will be a recurring theme and will be discussed in more detail later in this paper.

Approximately 20 percent identified shared resource allocation and determination of priorities among squadrons as benefits. This answer came with no caveats and appears to be the area where the DOGMs are having the most positive impact. Ten percent of the respondents mentioned coordinating with outside agencies such as MAJCOMs or depots as a benefit. Roughly 10 percent of those responding answered this question with "none" or "very little."

Problems

6. *Describe any problems created by the addition of the DOGM. (Please briefly explain)*

"The DOGM has frustrated the chain of command. Too many masters. The question is often asked 'who the hell owns maintenance?'"⁶

The above response from a DOGM highlights the biggest problem area identified by the survey. The positioning of the DOGM and his relationship with the SMOs and the FS/CCs was identified as a problem by over 25 percent of those surveyed in this "open question." This issue will be dealt with in greater detail in the Chain of Command section of the paper. Approximately 20 percent of the responses dealt with the recurring issue of lack of authority for the DOGM position and 20-25 percent of those surveyed responded with "little" or "none." The 5 percent range of response was created when some respondents stated "little" or "none" and then went on to describe a problem area.

Clearly Understood Responsibilities

7. Are the responsibilities of the DOGM clearly understood within your organization? From operating instructions or as delineated by group commander. (Please explain)

"The Air Force created this position, but to date has not clearly articulated the duties and responsibilities associated with the DOGM."⁷

The quote, from a sitting DOGM, is indicative of much of the frustration surrounding the lack of clear guidance on DOGM responsibilities. This was one of the decided messages that surfaced in the survey. All of the responses to this question fell into one of three categories; "yes," "no," and "yes, but."

Twenty-two percent of the responses fell clearly into the "yes" category and 41 percent clearly into the "no" category. The remaining 37 percent of the respondents began their answers in the affirmative but added phrases such as "only somewhat," "not by everyone," or "requires more specific guidance." Although it would be unrealistic to anticipate that everyone would clearly understand the responsibilities of a position, the fact that almost 80 percent either don't know or don't believe the guidance is adequate appears to be quite high. The issue of more

specific guidance on DOGM responsibilities will surface again in subsequent sections of the paper.

Necessary Authority

8. *Does the DOGM have the authority to affect aircraft maintenance in the operations group? (Please explain)*

“No and he shouldn’t. The SQ CC should be the only one who has that, exercised through the SMO.”⁸

“SQ/CCs still run their own squadron maintenance but the wise SQ/CC should listen to a voice of reason...”⁹

“Only if it pleases the zipper suits. Authority to do the ‘right thing’ is virtually non-existent.”¹⁰

The three quotations above only begin to capture the wide range of opinions on the authority of the DOGM. A few in operations have the same opinion that is expressed by the FS/CC in the first quote. Many in operations believe the DOGM can provide needed maintenance expertise to the senior leaders in the group as phrased by the OG in the second quote. And, many maintainers feel the DOGM does not have enough authority to enforce necessary decisions, though few would have expressed it as candidly as did the maintainer in the final quote.

Once again, all the scorable responses fell into one of three categories. Thirty-eight percent of those surveyed believed the DOGM has the authority to affect maintenance in the operations group, 44 percent indicated “yes, but,” and 18 percent were definite that the DOGM did not. The “yes” and “yes, but” numbers were higher than anticipated, especially when compared to the large percentage of personnel who advocated increasing the DOGMs authority in survey question four. This issue will subsequently be discussed in detail, but merited mentioning now for comparison purposes.

Analysis yielded several reasons for the “yes, but” responses. Approximately 35 percent believed that the DOGM could affect maintenance, but the authority was too limited to have the necessary impact. This was especially true of aircraft maintainers. An additional 25 percent indicated that the authority of the DOGM was predicated on his ability to build rapport with the senior operations and maintenance leaders in the wing or the personality of the OG. A final factor impacted the number of “yes” responses. One-half of the outright “yes” responses were clustered among only four bases. At three of the bases, responses indicated that the OG had very clearly delineated the responsibilities and authority for aircraft maintenance within their groups.

As the responses showed, there is a wide range of opinion on what authority the DOGM really has, and what he should have. The situation might be clearer if the operating instructions were more specific, and definitive guidance from an OG to his key leaders definitely helps. However, the authority issue is related to the question of structure and the chain of command.

Chain of Command Issues

9. Are there any communication or ‘chain of command’ issues created by the addition of the DOGM? (Please briefly explain)

“Conflicts between the DOGM and the flying squadron commanders often place the SMOs in a no win position.”¹¹

“Sometimes the MAs (SMOs) forget who their boss is. It’s the SQ/CC not the DOGM.”¹²

No other survey question returned a stronger message from the field than did this one on the chain command. The two quotations above, the first from a sympathetic Chief and the second from a FS/CC, capture the essence of the dilemma. The very structure of the organization and the placing of the DOGM creates a situation that can be challenging for the DOGMs and the FS/CCs and quite frustrating for some of the SMOs. The DOGM is a deputy, working for the OG, and not in the chain of command of the FS/CCs and the SMOs. However, as the senior

maintainer in the group, he has a certain degree of influence over aircraft maintenance and maintainers. And, as noted by one SMO in the survey, "The DOGM and the SQ/CC don't always have the same priorities."¹³

Almost 80 percent of the respondents indicated there were chain of command problems created by the addition of the DOGM. There are those that might argue that no deputy positions are in the direct chain of command, regardless of the organization, and this situation is no different. However, as several respondents pointed out, what makes this situation different is the dynamics of dealing with maintenance issues in the Operations Group. Operators are exposed, but not trained, to handle challenging maintenance issues. The real expertise in the group normally lies with the DOGM.

Although the DOGM can certainly do a lot of things to help the SMOs, when there are contentious issues and potential conflict between the DOGM and the FS/CC, the SMOs are put in a very difficult situation. One LG, a former DOGM, remarked about SMOs, "Who do I listen to in a dilemma of conscience, the voice of experience or the FS/CC...my boss?"¹⁴

Some issues already identified with authority and responsibility clearly exacerbate the chain of command problems resulting from the lack of clear lines of authority and responsibility within the maintenance structure of the Operations Group. Is there a better organizational alignment? Can some things be done to lessen the chain of command dilemma for the SMOs? Those are questions to be dealt with later in the paper.

Personality Dependent

10. Would you say this system with the DOGM is more or less 'personality dependent' than the organizational setup prior to the objective wing reorganization? (Please explain)

“More. The old 66-5/66-1 structures established clear lines of responsibility/authority. A DOGM’s success today largely depends on how much leeway the OG gives them and how well they get along with the Ops Squadron CCs.”¹⁵

“Definitely more. Reason is the effectiveness of this job is totally based on the leadership and diplomacy skills of the incumbent. [The] Old organization had the formal chain of responsibility with authority to fall back on in the absence of charismatic leadership.”¹⁶

This survey question provided the clearest majority with 96 percent of respondents indicating the current system was more personality dependent. As shown in the two quotes above, most responses pointed to the lack of clear lines of responsibility and authority as the root cause. As one SMO noted, “Now, a force of personality must exist for the DOGM to effect substantive change.”¹⁷

There were also survey responses that pointed to the personality of the OG as being critical to success. In the absence of necessary guidance, how and even if the OG clearly defines and communicates the rules of engagement between key group leaders is vital. As with several of the previous issues, it appears that responsibility and authority, or the lack thereof, play a major role in determining the level of personality dependency of the system.

Factors Influencing DOGM Success

11. What do you feel is the most important factor influencing the overall effectiveness of the DOGM? (Please explain)

“Give him what he needs to do the job--authority!”¹⁸

“Without written guidance, the position is completely dependent on the personality of the DOGM and the expertise/background that he/she brings to the position.”¹⁹

The overwhelming response to this question was authority; nearly 50 percent of the respondents included authority or backing from the OG in their answers. No other “open-ended” question in the survey had a single response with such a great percentage. These are not new

themes for this paper. What did arise in this question that hadn't been brought out previously was the issue of the importance for the DOGM to have the necessary knowledge, background, and/or expertise for the job. Comments on this subject area ranged from weapons system knowledge, to communications expertise, to a proper flight line background. One deputy LG warned that there are, "too many opportunities to place inexperienced Lt Cols as DOGMs with manpower shortages."²⁰ So, in addition to backing the DOGM with the proper authority, OGs should ensure the position is vested in someone with the right background and expertise.

Recommended Changes

4. *If you could make a change to the current DOGM concept, what would it be? (Please explain)*
- a. *More clearly define DOGM responsibilities, through AF or MAJCOM instructions.*
 - b. *Have greater delineation of responsibilities within your organization.*
 - c. *Give the DOGM more responsibility/authority over aircraft maintainers and/or maintenance policies within the operations group.*
 - d. *Abolish the position, it is an unnecessary hindrance.*
 - e. *No changes are necessary, everything is fine as is.*
 - f. *Other _____.*

"Spell out, in detail, responsibility/authority and who works for him. Everyone else has this."²¹

"Give the DOGM more authority, i.e. separate the idea of Ops over the DOGM, give him/her the freedom to say 'No Way.'"²²

"We need to put some structure/standardization back into aircraft maintenance—the DOGM is a bandaid that's effective at some wings, not so effective at others. Create an AGS in the OG and put an O-5 in command of it."²³

"The only way to improve this position is to bring back the old DCM. Until then, you will have an O-6 operator writing an O-5 maintainer's performance report."²⁴

The four quotations above capture the essence of the overall response to the survey question on recommended changes. The wording in the question did not specifically prohibit more than one response, and approximately one-fourth of the respondents marked two or three choices. This did not affect the validity of the data captured, however it will keep the figures in the table

below from totaling 100 percent. In the columns below, the first number is the total responses and the second the percentage, each within a given category. The message for more authority and greater definition of DOGM responsibilities is clear.

Table 3 - Responses to Recommended Changes Question

Responses	Total #/%	Operations #/%	Maintenance #/%
A	28 - 38%	3 - 17%	25 - 45%
B	13 - 18%	3 - 17%	10 - 18%
C	36 - 49%	3 - 17%	33 - 59%
D	3 - 4%	0 - 0%	3 - 5%
E	10 - 14%	9 - 50%	1 - 2%
F	11 - 15%	3 - 17%	8 - 14%

Source: Compilation of returned surveys.

Giving the DOGM more authority and responsibility, Response C, was easily the most popular response chosen by 49 percent of the respondents. However, there appears to be a significant disparity between operations and maintenance on this issue. Nearly 60 percent of the maintainers identified the need for more authority, while only three operators, 17 percent, chose that response. The prevailing response among operators was E, no changes necessary. An even 50 percent of those in operations chose that answer. On the contrary, only one maintainer thought the best option was to leave the system as is; a former SMO within weeks of becoming a DOGM.

Response F, "other", in most cases indicated a call for more authority. Four of the answers from maintainers flatly called for the return of the DCM. However, much more interesting were the five responses, including two from Operations, that cited the need to return to some type of AGS concept with the maintainers working in a single squadron. This is not a surprising answer from the maintainers. However, these answers from operators means that when combined with

their answers to Response C, that nearly one-third recognize the need to increase the formal authority given to the senior maintenance person in the Operations Group.

Based on previous survey questions, it was not surprising that Response A, more clearly defining DOGM responsibilities, got strong support. Again, there was some disparity between Operations and Maintenance, but not as significant as the distinction on the responses for more authority. Finally, there were only three of seventy-four scorable responses that advocated abolishing the position, Response D. All were from maintainers who typically felt, "It is a bandaid approach to a lack of senior maintenance knowledge in the operations group."²⁵

Because some respondents included their second and third choices and others did not, it is difficult to draw definitive conclusions from merely a statistical comparison. However, a few interesting trends were evident. The strong backing for the choices involving increasing authority and defining responsibilities seemed to validate earlier survey data. And despite an Operations and Maintenance variance, when taken in aggregate, nearly one-third of the operators surveyed believed the best improvement choice involved an increase in authority. Finally, the percentage of operators who believed the system was fine and needed no changes corresponds well with the high satisfaction ratings identified previously in the survey.

There are noticeable satisfaction rating differences between some positions, and also certain disparities between Operations and Maintenance on several of the key issues. What remains is to tie the data back to the survey questions, seek logical conclusions based on the data, and determine what meaningful recommendations can be made to those who can affect a positive change.

Notes

¹ *The Military Balance 1999-2000*. Oxford University Press, 1999.

² Author's opinion based on survey data.

³ Message. 071421Z MAR 97. US Air Force. From COMACC to subordinate wings. 7 March 1997.

⁴ Survey #379. Response to question 5.

⁵ Survey #383. Response to question 5.

⁶ Survey #150. Response to question 6.

⁷ Ibid. Response to question 1.

⁸ Survey #260. Response to question 8.

⁹ Survey #379. Response to question 8.

¹⁰ Survey #389. Response to question 8.

¹¹ Survey #381. Response to question 6.

¹² Survey #363. Response to question 6.

¹³ Survey #377. Response to question 6.

¹⁴ Survey #80. Response to question 9.

¹⁵ Survey #201. Response to question 10.

¹⁶ Survey #80. Response to question 10.

¹⁷ Survey #10. Response to question 10.

¹⁸ Survey #389. Response to question 11.

¹⁹ Survey #350. Response to question 11.

²⁰ Survey #230. Response to question 11.

²¹ Survey #371. Response to question 4.

²² Survey #375. Response to question 4.

²³ Survey #201. Response to question 4.

²⁴ Survey #362. Response to question 4.

²⁵ Survey #90. Response to question 4.

Part 4

Conclusions

The objective wing structure does not work--the DOGM position was created in a response to that failure. It is not a fix--it's a bandaid.

Survey Respondent #24

The DOGM is the reason that we have one great team and not four separate teams going in different directions.

Survey Respondent #280

As you can see from the quotations above from two maintainers, opinions are mixed on the utility of the DOGM concept. It's time to review the research questions in light of the survey data and look for some meaningful conclusions.

Satisfaction

1. To what extent are field level operations and maintenance leaders satisfied with the effectiveness of the DOGM?

With an overall rating of just over 3.3, satisfaction can be categorized as just above neutral on the 5-point Likert scale. Although it is not possible to make sweeping generalizations about the entire population based on a single survey, with over seventy-five completed surveys and a return rate of approximately 40 percent, it is possible to make some assumptions of overall opinion that will facilitate meaningful discussion.

Noticeable from the satisfaction ratings is a significant difference in the opinions of operators and maintainers. The high ratings for Operations overall and OGs specifically are positive. However, it was difficult to discern whether their satisfaction was based on their belief that the current DOGM concept was "on target" or if it was merely an improvement to not having a senior maintainer in the group at all. There were OGs who believed some positive changes could be made to the current system, yet still indicated their satisfaction with ratings of four or five.

Additionally, one would think that even "satisfied" operators might be concerned if too many experienced maintenance leaders had significantly different opinions on the DOGM concept. Of particular interest are the ratings from the DOGMs themselves. They were the lowest of any group surveyed and the only ones on the "dissatisfied" side of neutral. Although some of their survey responses relayed that they were having a positive impact, few believed that they had the necessary influence to make the position what it needed to be.

With overall Maintenance ratings a full point lower than Operations, one would have to wonder why. There were admittedly a few maintainers who appeared to still harbor some resentment that flight line maintenance had been moved under Operations¹, but their numbers constituted less than ten percent of the sample population. More importantly, from the vast majority of respondents who provided well thought out rationale as to their lack of overall satisfaction, two major themes emerged; inadequate guidance on DOGM responsibilities and lack of authority to have the necessary impact. With only lukewarm satisfaction and the preponderance of comments concentrated in two major areas, some important improvement areas should emerge as the focus turns to the second research question.

Recommended Changes

2. What changes can be made to the current concept to make it more effective?

Although some benefits were identified from the implementation of the DOGM, the majority of the respondents did not believe the position was what it could be. The very structure of the organization can place the DOGM and FS/CC at odds and the SMO in a difficult situation because there is not always a clear understanding of the maintenance lines of authority. The survey revealed the situation is exacerbated by maintenance instructions that are too vague and a lack of authority vested in the DOGM. There is not consensus on whether the DOGM should be an advisor only or given some formal authority. Addressing the issues of responsibility and authority should help clarify the issues for those trying to make the concept work.

More Clearly Define DOGM Responsibilities

The message from the field on this issue was clear. Almost 80 percent of the survey respondents did not feel the current guidance on DOGM responsibilities was adequate. As indicated in the previous section of the paper, in so many instances when given an opportunity to explain their survey responses, lack of clear definition of DOGM responsibilities emerged.

“Written job descriptions in AF instructions are so vague to be useless...simply looks like a laundry list of additional duties. Ability of the DOGM to perform is pretty much based on the personality of the OG.”²

The opinion above from a current DOGM is a reflection of the frustration expressed by many in the survey. Greater definition of DOGM responsibilities in AF and/or MAJCOM instructions would go a long way in alleviating this frustration. Better job definition and more clearly defined roles would also be an important first step in easing the tension that can exist between DOGMs and FS/CCs when the organizational structure and competing priorities put them at odds.

As mentioned previously, it is the position of those at headquarters not to specify job responsibilities for those in deputy positions. For a deputy LG and even a deputy OG for operations this rationale may work fine. However, for the DOGM the situation is different. What makes this situation unique are the dynamics of dealing with maintenance issues in the Operations Group. Operators are exposed, but not really trained, to handle challenging maintenance issues. The maintenance expertise in the group resides in the DOGM position, but there is not clear understanding of the DOGM's role. When the message from the field is so strong, there should be little real controversy from the Headquarters' perspective to making changes to the 21-101 series maintenance instructions. What will not be as easy to address is the issue of DOGM authority.

Give the DOGM More Authority

Choosing the appropriate role for the DOGM and giving the requisite authority to accomplish those responsibilities will be more of a challenge. The central issue facing Air Force leadership is whether the DOGM should fill some sort of advisory role for the OG or should have greater authority to affect aircraft maintenance in the Operations Group.

A clear majority of maintainers surveyed indicated the need for more authority for the DOGM. Among FS CCs, opinions were split. Some remarked, "Absolutely not!"³ while others believed "The DOGM needs command over the maintenance he is responsible for."⁴ More of the senior operations leaders surveyed saw the need for more authority in one form or another.

Though not within the scope of this project to categorically define the best option to increase DOGM authority, some survey respondents provided enough detail to identify potential solutions. Only four maintainers overtly called for restoring the DCM. The recommendation that appeared with the most frequency advocated a return to an AGS type organization. Some

believed leaving the maintainers in the Operations Group and creating a large flight line maintenance squadron was the best option. Others called for placing the maintainers in a large squadron within the Logistics Group. Still some indicated it did not matter under which group they were assigned as long as maintenance was functionally aligned under a maintenance commander.

Is there some way to make the SMOs and maintenance in the Operations Group more responsible to the DOGM without making major structural changes? One option that surfaced in a number of surveys was to make the DOGM a colonel. Since most operations group deputies are full colonels, many believed the DOGM, as an lieutenant colonel, was not perceived as a full deputy. They believed this perception was affecting their authority and consequently their ability to positively influence maintenance. One DOGM wrote, "If you are not seen by the squadron commanders as a full up Deputy, you are simply an advisor."⁵ A similar opinion was expressed by several senior operators, including this colonel who wrote, "The DOGM must be co-equal with the OG/CD (Operations Group Deputy for Operations)."⁶ Making the DOGM an O-6 could go along way to changing the perception that the DOGM is not a full deputy and that maintenance is not given adequate consideration in the Operations Group.

Senior Leader Perspective

In a final attempt to validate the need to address the areas of clarifying responsibilities and increasing the authority of the DOGM, the survey responses of the most experienced unit level leaders were reviewed separately. The target population for this analysis were the O-6s. Because including rank was not a requirement on the survey, only eight respondents could be positively identified as coming from a full colonel; five from Operations and three from

Maintenance. Of these eight, only one felt the concept needed no changes. The remaining seven all made recommendations concerning responsibility or authority, and most cited both.

“The DOGM should have a charter that gives him the authority within the OG complex to ensure results, rather than making input only.”⁷

“Clear lines of authority. The DOGM is typically a graduated squadron commander and should outrank and have authority over all squadron SMOs and CCs. As such, when they say something it should be regarded as coming from the mouth of the OG.”⁸

The comments from the LG and OG above capture the sentiment expressed by the majority of their peers in the survey. Their remarks correctly identify the heart of the problem—the lack of clear lines of authority. In many organizations, it’s a confused relationship between the DOGM, FS/CCs, and SMOs. In the field, they see the shortcomings and are feeling the frustration of the current DOGM set up and recognize the need to make some changes.

Closing Remarks

There are many challenges facing OGs today, not the least of which is the responsibility for flight line maintenance in a very dynamic environment. At bases where there was broad based satisfaction with the DOGM concept, there appeared to be a central theme. In the absence of adequate higher headquarters guidance, the OGs were very specific within their organizations on what they expected the relationship to be between their key personnel. The message to OGs, although simple, is critical. With the current organizational mix, and a DOGM position that is not universally understood, it is imperative that you meet face-to-face with your commanders and your deputies and leave no doubt as to your wishes relative to their working relationships. They all need to know your expectations on their responsibilities and the boundaries of their authority as it relates to aircraft maintenance.

There are at least two challenges for higher headquarters relating to the DOGM situation. First, there needs to be serious reconsideration given to the policy of not specifying responsibilities for the DOGM. All of the survey data indicates there would be little controversy over this action and the potential benefits are considerable. Even if nothing is done to increase the authority of the DOGM, it would be beneficial to clearly delineate their responsibilities.

The second item is the real challenge. The Air Force needs to make a decision on the role of the DOGM. Many perceive this position as a "bandaid" and not nearly as beneficial as it could be given proper authority. Though beyond the scope of this paper to make an informed, specific recommendation, enough survey respondents, both Operations and Maintenance, saw the need for increased authority that it warrants serious consideration from higher headquarters.

Though initially created as a compromise when the MAJCOMs couldn't agree on realignment proposals, the DOGMs are having an impact. However, many view the position as little more than a bandaid created to assuage those concerned with trusting operations with control of flight line maintenance. They don't believe the DOGM has been accorded full deputy status and see the need for more authority for them to be able to effectively advocate maintenance concerns in the Operations Group.

The challenges facing Air Force leaders today is as great as any time in the recent past. Expeditionary deployment requirements to places across the globe are surfacing faster than the old requirements are going away. With a smaller force and an aging fleet, the mission does not get any easier and cooperation between the operations and maintenance disciplines is vital. The most junior officer who completed a survey captured the idea best.

"The health of the entire USAF fleet demands a proactive, can't-have-it-all type mentality on the part of the maintenance AND ops communities. We, as maintainers, need to better understand the pilot communities' wants and needs and they need to understand ours."

To facilitate cooperation and to ensure maintenance concerns are advocated and understood, the DOGM, or some senior maintenance leader if not the DOGM, is needed as long as there are flight line maintainers assigned to the Operations Group. Maintenance and Operations leaders in the field, through their survey responses, have made it clear that there needs to be some fundamental changes addressed concerning the authority of the DOGM and how their responsibilities are communicated in the maintenance instructions. This paper is only the first step in addressing those issues. What remains is for our experts at headquarters to take the next step and make the position more effective.

Notes

- ¹ Author's opinion based on sentiments expressed in survey responses.
- ² Survey #361. Response to question 4.
- ³ Survey #260. Response to question 4.
- ⁴ Survey #386. Response to question 4.
- ⁵ Survey #361. Response to question 5.
- ⁶ Survey #379. Response to question 11.
- ⁷ Survey #270. Response to question 2.
- ⁸ Survey #120. Response to question 11.
- ⁹ Survey# 10. Response to question 4.

Appendix A

Deputy Operations Group Commander for Maintenance (DOGM) Survey

Air Command and Staff College Research Project
USAF SCN: 99-99

1. What are the major focus areas of the DOGM in your wing? (for example: maintenance discipline, standardization, shared resource allocation, scheduling, training, deployment oversight, reviewing unit maintenance, others)

2. What SHOULD the focus areas be? (Please briefly explain the differences.)

3. What is your overall satisfaction with what adding the DOGM has done for wing level aircraft maintenance?

Extremely Dissatisfied	Dissatisfied	Neutral	Satisfied	Extremely Satisfied
1	2	3	4	5

4. If you could make a change to the current DOGM concept, what would it be? (Please explain)
- g. More clearly define DOGM responsibilities, through AF or MAJCOM instructions
 - h. Have greater delineation of responsibilities within your organization
 - i. Give the DOGM more responsibility/authority over aircraft maintainers and/or maintenance policies within the operations group
 - j. Abolish the position, it is an unnecessary hindrance

- k. No changes are necessary, everything is fine as is
- l. Other _____

5. How does the DOGM benefit your organization?

6. Describe any problems created by the addition of the DOGM? (Please briefly explain)

7. Are the responsibilities of the DOGM clearly understood within your organization? From Operating Instructions or as delineated by group commander. (Please explain)

8. Does the DOGM have the authority to affect aircraft maintenance in the operations group? Is the authority written? Implied from group commander?(Please explain)

9. Are there any communication or 'chain of command' issues created by the addition of the DOGM? (Please briefly explain)

10. Would you say this system with the DOGM is *more* or *less* 'personality dependent' than the organizational setup prior to the objective wing reorganization? (Please explain)

11. What do you feel is the most important factor influencing the overall effectiveness of the DOGM? (Please explain)

12. What is your current position? OG LG DOGM FS/CC SMO Chief

In the last 3 years, have you held any of the other positions listed above? If so, which one(s)?

Glossary

ACC	Air Combat Command
AETC	Air Education and Training Command
AF	Air Force
AFR	Air Force Regulation
AGS	Aircraft Generation Squadron
AMC	Air Mobility Command
AMU	Aircraft Maintenance Unit
CAF	Combat Air Forces
COMACC	Commander, Air Combat Command
CRS	Component Repair Squadron
CSAF	Chief of Staff of the Air Force
DOGM	Deputy Operations Group Commander for Maintenance
EMS	Equipment Maintenance Squadron
IG	Inspector General
LG	Logistics Group, also used for Logistics Group Commander
MAJCOM	Major Commands
MSAT	Maintenance Standardization and Assistance Team
MSET	Maintenance Standardization and Evaluation Team
OG	Operations Group, also used for Operations Group Commander
OSS	Operations Support Squadron
PACAF	Pacific Air Forces
QAFA	Quality Air Force Assessment
SMO	Squadron Maintenance Officer
UEI	Unit Effectiveness Inspection
USAFE	United States Air Forces in Europe

Bibliography

- Message. 020700Z APR 96. US Air Force. From PACAF LG to command OG and LG CCs, 2 April 1996.
- Message. 071421Z MAR 97. US Air Force. From ACC/CC to command wing CCs, 7 March 1997.
- Message. 061800Z AUG 96M. US Air Force. From ACC/CC to AETC, PACAF, and USAFE CCs, 6 August 1996.
- Message. 221643Z NOV 99. US Air Force. From HQ USAF/IL to MAJCOM LGs, 22 November 1999.
- Message. 121910Z JAN 00. US Air Force. From ACC/CV to AIG 7151 CCs. 12 January 2000.
- Message. 041638Z JAN 00. US Air Force. From USAFE/CC to command CCs. 4 January 2000.
- AFR 66-5. *Production Oriented Maintenance Organization*, July 1979.
- TAC/USAFE/PACAF/AFRESR 66-5. *Production Oriented Maintenance Organization*, March 1991.
- ACCI 21-101. *Objective Wing Aircraft Maintenance*. July 1997.
- ACCI 21-101. *Objective Wing Aircraft Maintenance*. October 1998.
- USAFEI 21-101. *Objective Wing Aircraft Maintenance*. January 1999.
- Michels, Joseph B., Maj, PhD, CPI, USAF. *Tactical Fighter Wing Reorganization. The Implications for the Maintenance Officer*. Air Force Journal of Logistics. Vol XVI, No. 2, pgs 21-23. Summer 1992.
- Rine, Joseph R., Jr., Maj, USAF. *The Maintenance Officer Role in the Objective Wing Organization*. Air Force Journal of Logistics. Vol XVI, No. 2, pg 24. Summer 1992.
- Pauly, James D., Jr., Lt Col, USAF. *Aircraft Maintenance Career Field*. Air Force Journal of Logistics. Vol XIX, No. 1, pgs 24-25, 31. Spring 1995.
- Goddard, Maj Gen Richard N., Director of Logistics, Air Combat Command. To HQ ACC/XP. Subject: Organization Change Request - HQ ACC requests Maintenance Management Office be established under the Operations Group Commander, 29 December 1995.