

---

## PHASE-LOCKED FIBER LASER ARRAY

Gregg Switzer

AdvR, Inc.  
910 Technology Blvd.  
Suite K  
Bozeman, MT 59718

April 2001

Final Report

APPROVED FOR PUBLIC RELEASE; DISTRIBUTION IS UNLIMITED.

20010907 121



**AIR FORCE RESEARCH LABORATORY**  
Directed Energy Directorate  
3550 Aberdeen Ave SE  
**AIR FORCE MATERIEL COMMAND**  
**KIRTLAND AIR FORCE BASE, NM 87117-5776**

---

AFRL-DE-TR-2001-1035

Using Government drawings, specifications, or other data included in this document for any purpose other than Government procurement does not in any way obligate the U.S. Government. The fact that the Government formulated or supplied the drawings, specifications, or other data, does not license the holder or any other person or corporation; or convey any rights or permission to manufacture, use, or sell any patented invention that may relate to them.

This report has been reviewed by the Public Affairs Office and is releasable to the National Technical Information Service (NTIS). At NTIS, it will be available to the general public, including foreign nationals.

If you change your address, wish to be removed from this mailing list, or your organization no longer employs the addressee, please notify AFRL/DELO, 3550 Aberdeen Ave SE, Kirtland AFB, NM 87117-5776.

Do not return copies of this report unless contractual obligations or notice on a specific document requires its return.

This report has been approved for publication.



DR. KENNETH D. SHAW  
Project Manager

FOR THE COMMANDER



THOMAS ALLEY, Lt Col, USAF  
Chief, Solid State Laser Branch



DR. EARL GOOD  
Director, Directed Energy Directorate

# REPORT DOCUMENTATION PAGE

Form Approved  
OMB No. 0704-0188

Public reporting burden for this collection of information is estimated to average 1 hour per response, including the time for reviewing instructions, searching existing data sources, gathering and maintaining the data needed, and completing and reviewing this collection of information. Send comments regarding this burden estimate or any other aspect of this collection of information, including suggestions for reducing this burden to Department of Defense, Washington Headquarters Services, Directorate for Information Operations and Reports (0704-0188), 1215 Jefferson Davis Highway, Suite 1204, Arlington, VA 22202-4302. Respondents should be aware that notwithstanding any other provision of law, no person shall be subject to any penalty for failing to comply with a collection of information if it does not display a currently valid OMB control number. PLEASE DO NOT RETURN YOUR FORM TO THE ABOVE ADDRESS.

|   |                                    |   |  |   |  |
|---|------------------------------------|---|--|---|--|
| <b>1. REPORT DATE (DD-MM-YYYY)</b><br>04-19-2001  |                                    | <b>2. REPORT TYPE</b><br>Final Technical Report |  | <b>3. DATES COVERED (From - To)</b><br>March 2000 - April 2001        |  |
| <b>4. TITLE AND SUBTITLE</b><br>Phase-Locked Fiber Laser Array  |                                    |   |  | <b>5a. CONTRACT NUMBER</b><br>F29601-00-C-0077                        |  |
|   |                                    |   |  | <b>5b. GRANT NUMBER</b>   |  |
|   |                                    |   |  | <b>5c. PROGRAM ELEMENT NUMBER</b><br>65502F                           |  |
| <b>6. AUTHOR(S)</b><br>Dr. Gregg Switzer  |                                    |   |  | <b>5d. PROJECT NUMBER</b><br>3005                                     |  |
|   |                                    |   |  | <b>5e. TASK NUMBER</b><br>D0  |  |
|   |                                    |   |  | <b>5f. WORK UNIT NUMBER</b><br>DD                                     |  |
| <b>7. PERFORMING ORGANIZATION NAME(S) AND ADDRESS(ES)</b><br>AdvR, Inc.<br>910 Technology Blvd.<br>Suite K<br>Bozeman, MT 59718   |                                    |   |  | <b>8. PERFORMING ORGANIZATION REPORT NUMBER</b>                       |  |
| <b>9. SPONSORING / MONITORING AGENCY NAME(S) AND ADDRESS(ES)</b><br>AFRL/DELO<br>3550 Aberdeen Ave, SE<br>Kirtland AFB, NM 87117-5776   |                                    |   |  | <b>10. SPONSOR/MONITOR'S ACRONYM(S)</b>                               |  |
|   |                                    |   |  | <b>11. SPONSOR/MONITOR'S REPORT NUMBER(S)</b><br>AFRL-DE-TR-2001-1035 |  |
| <b>12. DISTRIBUTION / AVAILABILITY STATEMENT</b><br>Approved for public release; distribution unlimited.  |                                    |   |  |   |  |
| <b>13. SUPPLEMENTARY NOTES</b>  |                                    |   |  |   |  |
| <b>14. ABSTRACT</b><br>We present a rugged method for controlling the phase of multiple, continuous wave (cw) laser beams using a compact device for coherent addition of radiation. The concept employs an array of electro-optically controlled waveguides in Potassium Titanyl Phosphate (KTP). The phase of each beam is controlled by altering the index of refraction of each waveguide in the array with an individually addressable voltage. A fiber array containing 16 single mode fibers is aligned to an array of KTP waveguides with an average coupling efficiency of 50%. Pi phase shifts are achieved with voltages as low as 30V. This technique provides a direct path to adding up an arbitrary number of low power fiber lasers and/or fiber amplifiers to obtain a high-power output. Furthermore, KTP is transparent from 350nm to 4500nm, so the device will work with many different kinds of lasers. |                                    |   |  |   |  |
| <b>15. SUBJECT TERMS</b><br>Phase-locking, Electro-optic, waveguides, coherent beam addition  |                                    |   |  |   |  |
| <b>16. SECURITY CLASSIFICATION OF:</b>  |                                    |   | <b>17. LIMITATION OF ABSTRACT</b><br>Unlimited | <b>18. NUMBER OF PAGES</b><br>18                                      | <b>19a. NAME OF RESPONSIBLE PERSON</b><br>Dr. Kenneth Shaw       |
| <b>a. REPORT</b><br>Unclassified  | <b>b. ABSTRACT</b><br>Unclassified | <b>c. THIS PAGE</b><br>Unclassified             |  |   | <b>19b. TELEPHONE NUMBER (include area code)</b><br>505-846-6956 |

(This page intentionally left blank.)

## TABLE OF CONTENTS

|  | <u>Page</u> |
|--|-------------|
| INTRODUCTION   | 1           |
| METHODS AND DISCUSSION   | 2           |
| TASK 1: FABRICATE AN ARRAY OF WAVEGUIDES IN KTP                            | 2           |
| TASK 2: COUPLE FIBER ARRAYS INTO AND OUT OF<br>THE WAVEGUIDES              | 3           |
| TASK 3: DEMONSTRATE ELECTRO-OPTICAL CONTROL<br>OF MULTIPLE BEAMS           | 4           |
| TASK 4: PREPARE DESIGNS FOR A SCALED UP DEVICE<br>AND FEEDBACK ELECTRONICS | 8           |
| TASK 5: PREPARE FOR PHASE II IMPLEMENTATION                                | 9           |
| CONCLUSIONS  | 11          |

## FIGURES

| <u>Figure</u> |  | <u>Page</u> |
|---------------|--|-------------|
| 1.            | View of waveguides embedded in KTP.  | 2           |
| 2.            | Positioning system used to align the waveguides to 16-fiber array.                           | 3           |
| 3.            | Measured coupling efficiency for each KTP waveguide.   | 4           |
| 4.            | Positions of the electrodes relative to the KTP waveguides.                                  | 4           |
| 5.            | Photo of a glass submount used for electro-optic control.                                    | 5           |
| 6.            | Completed submount with KTP crystal attached.  | 6           |
| 7.            | Set up for coupling light into and out of a single KTP waveguide.                            | 6           |
| 8.            | Set up of the HeNe interferometer used to measure electro-optic response.                    | 7           |
| 9.            | Oscilloscope trace showing phase control.  | 8           |
| 10.           | A design prototype device for coherent addition of radiation using the KTP phase controller. | 8           |
| 11.           | Mechanical drawing of the positioning and packaging platform for the phase control module.   | 10          |

## **Introduction.**

A variety of Air Force applications, including IR countermeasures, laser radar, and remote sensing would be greatly enhanced with higher-power continuous wave (cw) laser sources than are currently available. An attractive approach to achieving high-power cw lasers is to coherently combine multiple laser beams. Coherent combination has a primary advantage of being readily scalable so that an arbitrary number of low power lasers and optical amplifiers can be combined in phase to obtain a high power output.

A key problem with *all* coherent beam addition systems is precise phase control of multiple beams at the combined output. During the Phase I effort at AdvR Inc., an electro-optically controlled array of waveguides embedded in a Potassium Titanyl Phosphate (KTP) substrate that can adjust the phases of multiple laser beams was developed. The device developed in this Phase I effort is compact, with the waveguides spaced as closely as optical fibers can be packaged on a silicon optical bench. This technology promises to yield a device that is much smaller than competing technologies such as piezo-electric based devices.

## Methods and Discussion.

The objective of the Phase I project was to demonstrate the feasibility of adjusting the phase of light as it passes through a KTP waveguide using electro-optical control. To accomplish this, the following tasks were set forth in the Phase I proposal:

- Task 1.* Fabricate an array of waveguides in KTP.
- Task 2.* Couple fiber arrays into and out of the waveguides.
- Task 3.* Demonstrate electro-optic phase control of multiple beams.
- Task 4.* Prepare designs for a scaled up device and feedback electronics.
- Task 5.* Prepare for Phase II implementation.

The summary of the results for each of these tasks will now be presented.

*Task 1.* The first task for the SBIR Phase I was to fabricate an array of channel waveguides in KTP. Waveguide design and photolithography were performed at the Cornell Nanofabrication Facility (CNF). The waveguides were embedded into the patterned KTP chips using an ion exchange method, which was performed at AdvR. A photo of the end facet (left) and the top surface (right) of a KTP chip with ion-exchanged waveguides are shown in figure 1. Waveguides with widths of 3, 4 and 5  $\mu\text{m}$  were fabricated. The spacing between waveguides of matching widths is 127  $\mu\text{m}$ , which matches the fiber-to-fiber spacing of the input and output fiber array.

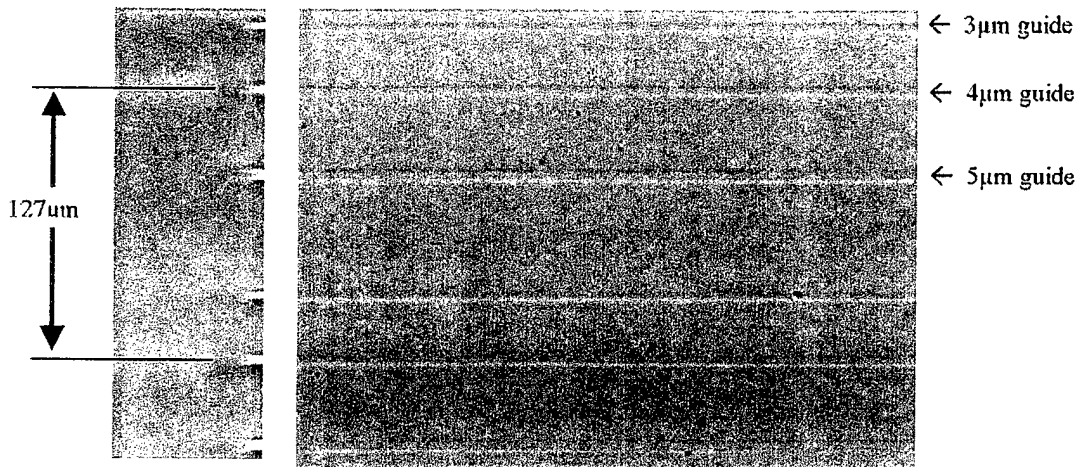

**Figure 1.** End view (left) and top view (right) of the waveguides embedded in KTP.



*Task 2.* The second task of the SBIR phase I was to couple a fiber array into and out of the waveguides. An array of 16 fibers was delivered from ACT Microdevices. Each fiber is precisely spaced from its neighbor by  $127\mu\text{m}$  using silicon V-groove technology. The fiber array was successfully coupled to the waveguide array in a KTP crystal using a HeNe laser as the illumination source. First, the coupling efficiency of the #1 fiber into the waveguide was optimized, then the #16 fiber was rotated into place and its coupling was optimized. This automatically coupled all other fibers, #2-15, into the waveguide array. The KTP crystal containing the waveguides (left), the fiber array (right), and positioning equipment is shown in figure 2. Line up was monitored under a microscope.

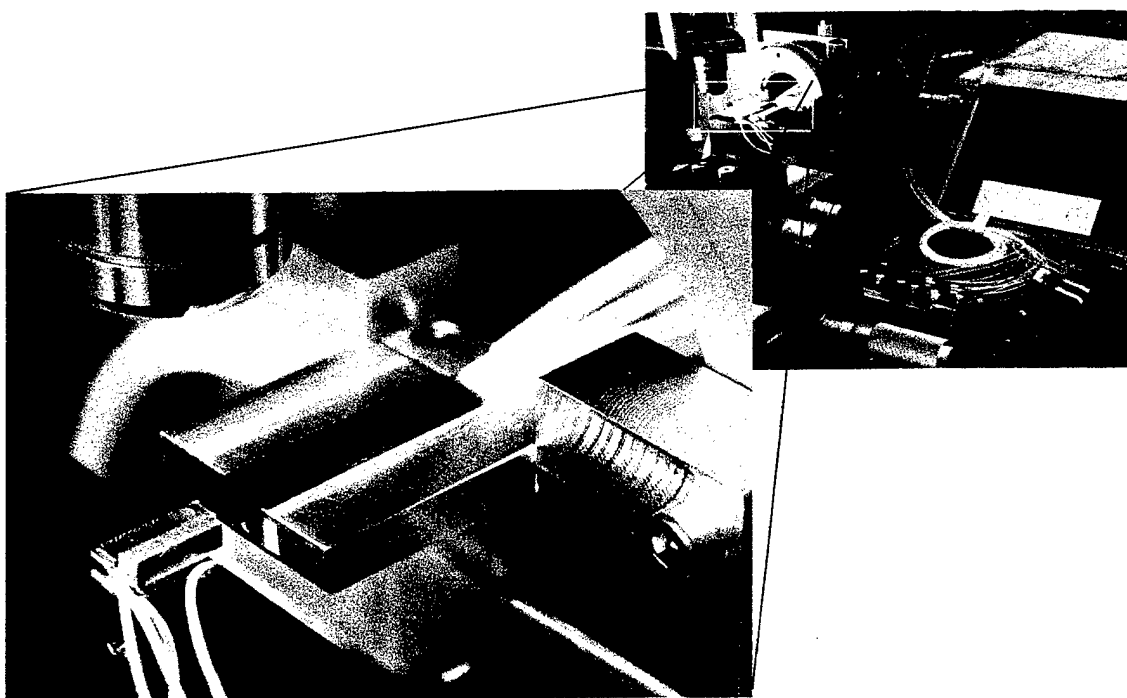

**Figure 2.** Positioning system used to align the array of waveguides in the KTP chip with the 16 fiber array.

Using this setup, an average coupling efficiency of 50% was obtained as shown in figure 3. Good coupling is expected because the numerical aperture of the waveguides in the KTP closely matches the numerical aperture of the single mode fibers. Variations in the coupling efficiencies are attributed to the multimode behavior of the 1060nm single mode fiber array transmitting the 633nm light from the HeNe. Smaller variations in coupling efficiencies are expected when operating at 1060nm.

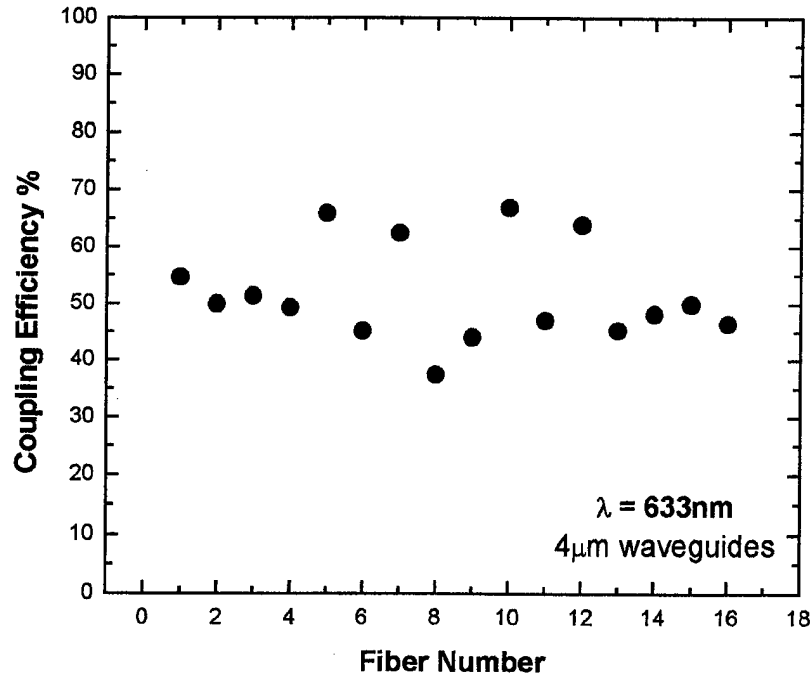

**Figure 3.** Measured coupling efficiency for each KTP waveguide using the setup in figure 2. A HeNe laser at 633nm was used as the illumination source for these measurements.

*Task 3.* The third task for the SBIR phase I was to demonstrate electro-optic phase control of multiple beams. An electric field was directed across an individual waveguide by placing the crystal over a glass submount containing microelectrodes. The most efficient way to direct the electric field across an individual waveguide was to place both the positive and ground electrode on the surface of the KTP waveguides rather than on opposite sides of the chip, as shown in figure 4.

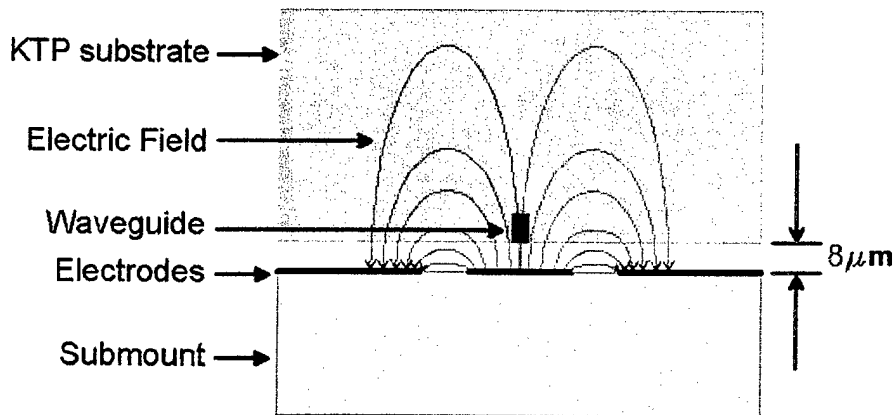

**Figure 4.** Schematic showing the position of the electrodes relative to a KTP waveguide.

The micro-electrodes, shown in figure 5, were designed at AdvR. The design pattern was transferred to glass substrates using contact lithography at Revtek, Inc. The substrates measure 1x10x11mm and contain gold electrodes. The electrodes were wire-bonded to small ceramic jumpers that could be soldered to standard wire and connected to a voltage supply. The KTP chip rests on top of the electrodes with its top surface face down.

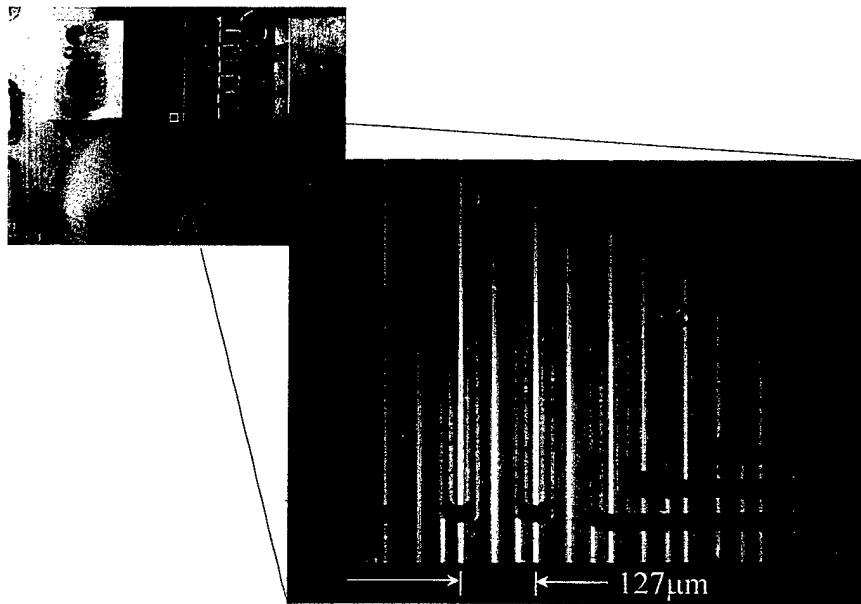

**Figure 5.** A glass submount containing many electrodes was used to direct an electric field across an individual KTP waveguide for electro-optic control.

The waveguides were aligned over the electrodes under a microscope and epoxied in place with UV cure epoxy. A specialized apparatus was developed to both accurately align the waveguides with the electrodes and compress the epoxy before curing. The completed electro-optic Phase Control Module (PCM) is shown in figure 6.

The PCM was placed in one arm of a Mach Zehnder interferometer to measure the phase shift of a single waveguide. Light from a HeNe laser was coupled into a selected waveguide in the PCM using standard microscope objectives as shown in figure 7. A schematic of the Mach Zehnder interferometer setup is shown in figure 8. A HeNe laser beam was split using a beam splitter. One arm was coupled into and out of a single KTP waveguide contained in the PCM. This arm of the interferometer was recombined with the reference arm to form circular interference fringes. An aperture was used to select the center fringe and the light was then imaged onto a photodiode. These

measurements determined the voltage requirements needed to control the phase of each individual waveguide.



**Figure 6.** The completed submount with KTP crystal attached (top left) and an expanded view of the waveguides (white) overlapping the electrodes (bottom right). This forms the Phase Control Module (PCM)

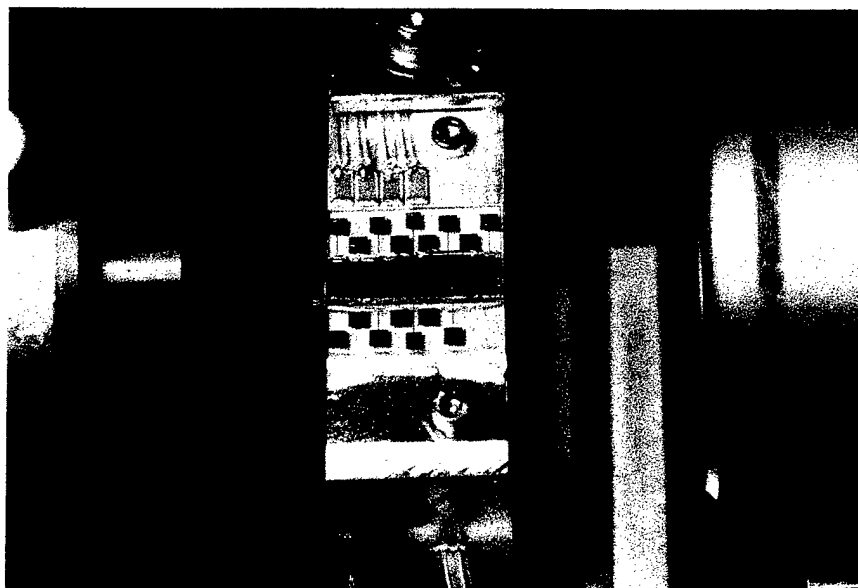

**Figure 7.** Light was coupled into a single waveguide attached to a glass submount (center) using a 15x microscope objective (left). Light diverging from the output of the waveguide was gathered and collimated using a 50x, far field microscope objective.

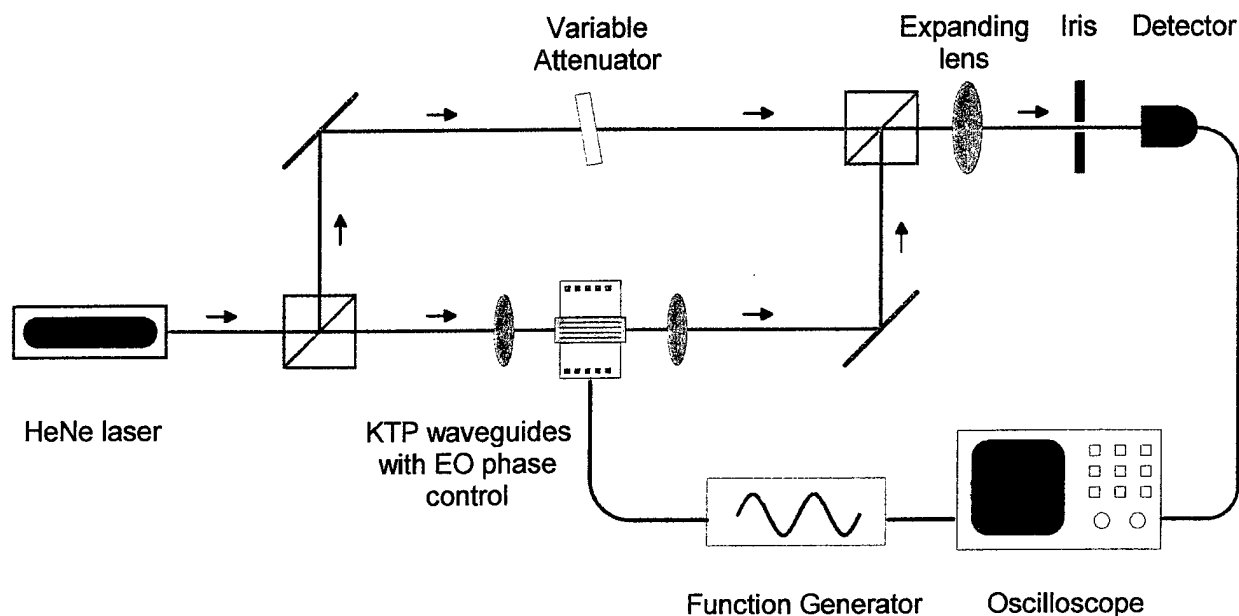

**Figure 8.** Set up of the Mach Zehnder interferometer used to measure the electro-optic phase control of a single KTP waveguide. This setup was used to measure phase shift as a function of applied voltage. Additionally, this setup was used to measure the level of cross talk between neighboring waveguides.

As the voltage to the PCM was changed, the phase of the radiation passing through the PCM varied accordingly, thereby shifting the fringe pattern. The phase shift as a function of applied voltage was quantitatively determined by simultaneously monitoring both the photodiode output and the applied voltage with a dual channel oscilloscope. Pi-phase shifts were measured by applying 30V to the PCM. Typical phase shift data is shown in figure 9.

The peak-to-peak drive voltage on this plot was set to a value somewhat larger than  $V_{\pi}$ . It should be noted that no measurable electro-optic crosstalk between neighboring optical waveguides was seen. In addition, cross talk was not expected because the spacing between the electrodes is 25 times greater than the electrode to waveguide spacing. Simultaneous electro-optic control of multiple waveguides required the PCM to be fiber coupled to a fiber array. The combination of fiber coupling and electro-optic control will be simultaneously demonstrated in the Phase II effort.

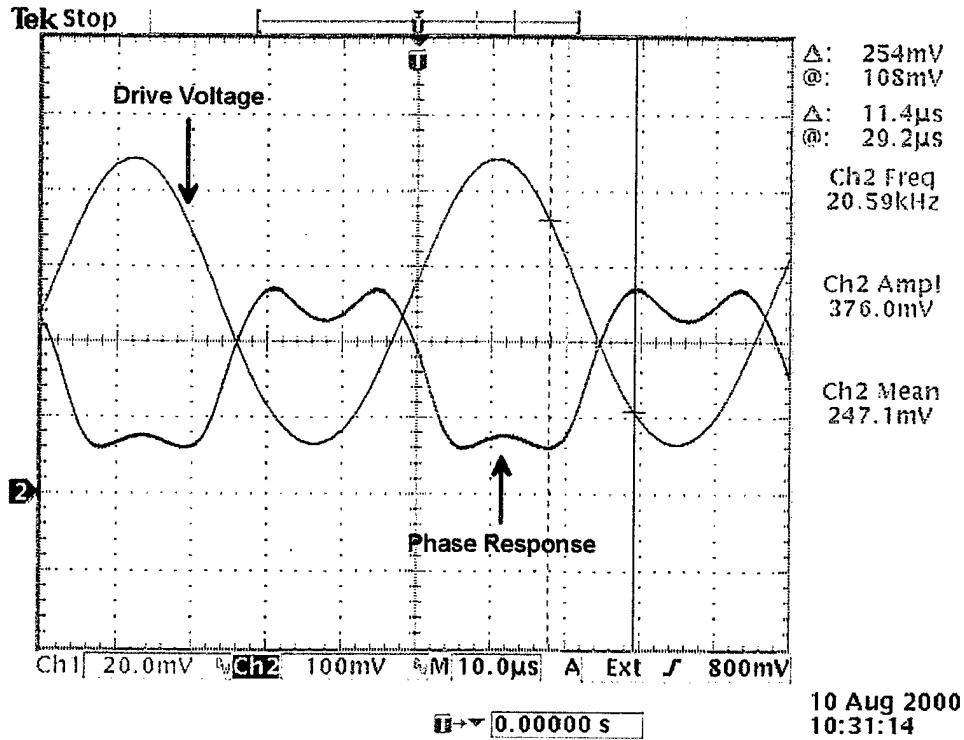

**Figure 9.** Oscilloscope trace of the drive voltage to a Phase Control Module (top trace) and the intensity of a single fringe imaged onto a photodiode (bottom trace). A  $\pi$  phase shift occurs when the photodiode output goes from a maximum to a minimum.

*Task 4.* Prepare designs for a scaled up device and feedback electronics. Figure 10 shows a prototype system for coherent addition of multiple beams.

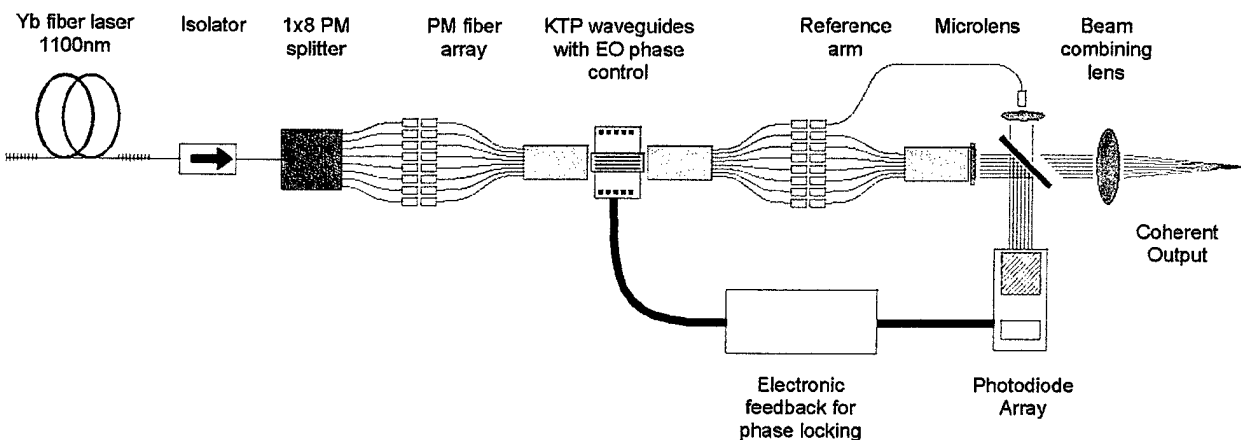

**Figure 10.** Schematic of a prototype laser system with feedback electronics for coherent addition of radiation. This system, proposed in the Phase II, uses the KTP phase controller developed during the Phase I effort.

The output from a master oscillator (Yb fiber laser) is divided into eight laser beams. The phase of each beam can be adjusted by an electro-optically controlled waveguide in the KTP crystal. The driving voltage is controlled by a feedback loop from a phase front sensor in order to add all seven arms coherently. The system shown above can be readily scaled to high power by splicing in a polarization-maintaining (PM) Yb fiber amplifier to each fiber before the output fiber array.

The proposed system is a fundamental building block for the high power laser being developed by the Air Force based on coherent beam addition. The low voltage phase controller will make precise manipulation of the combined phase front of the output beam possible. Thus, the beam can be configured to tightly focus its energy onto a distant target and allow for atmospheric corrections with excellent beam quality not achievable by conventional methods. It is important to note that this concept can be scaled to accommodate more than 8 beams, providing the ability to reach very high output power. Furthermore, the basic structure can be adapted to other wavelengths, thus expanding the range of commercial applications.

*Task 5.* Prepare for Phase II implementation. In the Phase II effort, we will fabricate a compact, robust, low-voltage phase controller based on this technology. A detailed CAD drawing for the positioning and packaging platform for the Phase Control Module, developed during the Phase I effort, is shown in figure 11. This platform will allow for fine  $x$ ,  $y$ , and  $z$  translation as well as tilt and rotation of each fiber array. Coarse alignment of the silicon array to the waveguides will be performed under a microscope. Fine alignment will be achieved by optimizing the coupling efficiency of the first and last fiber in the array. All the fibers in between will automatically be coupled.

It is important to note that this coupling scheme will scale to any number of fibers because only the first and last fiber in the array needs to be coupled. In addition to the positioning capabilities of this mounting system, it will also be designed such that the fiber arrays can be precisely locked in place. A cover will be fabricated to protect the entire assembly. Thus, the positioning system will also serve as a robust package for the PCM. This approach will simplify the packaging and allow for fine-tuning the alignment of the delivered device by the end user.

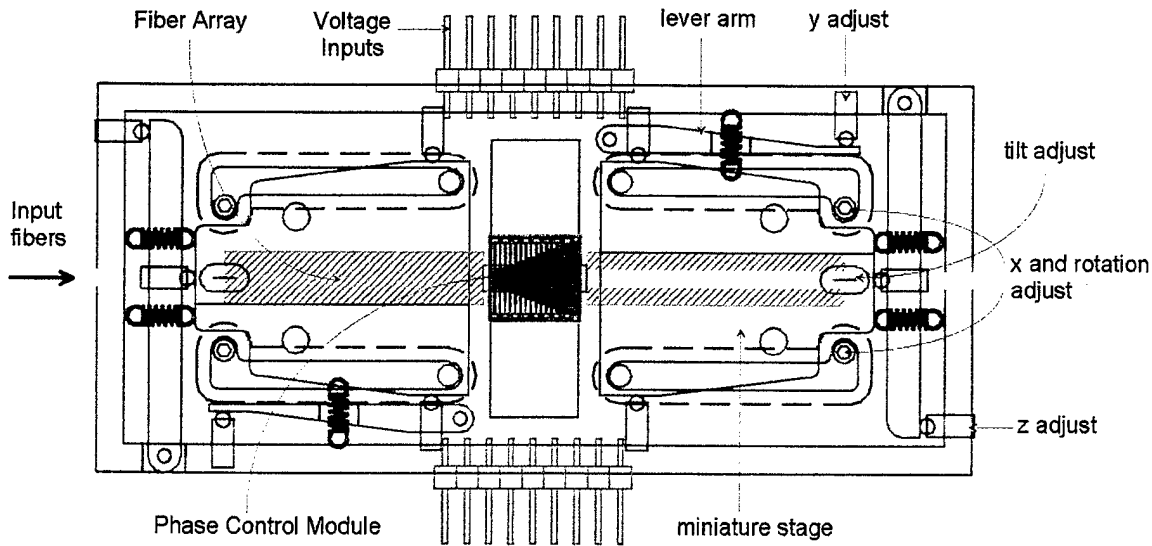

**Figure 11.** Mechanical drawing of the positioning and packaging platform for the Phase Control Module. Actual size of the pigtailed device will be slightly smaller than this drawing, measuring 4 x 1.75 x 0.75 inches.

The fiber coupled PCM will be implemented into the coherently recombined fiber laser system shown in figure 10. During the preparation of the Phase II proposal, commercial vendors were identified that could supply the remaining components of the laser system including:

- Yb fiber laser, 5W, 1100nm, narrow linewidth with polarized output
- High power, PM, fiber pigtailed isolator
- 1x8 PM fiber splitters, terminated with FC/APC connectors
- 8-fiber arrays with PM fibers, polished silicon V-groove, 250 $\mu$ m spacing
- Microlens array and single lens to collimate and overlap fiber array output
- Optics, photodiode array, and feedback electronics for phase sensing and control.

The entire system must maintain the polarization of the master oscillator to be recombined coherently at the output. Each component will be connected to the system using standard FC/APC connectors. This modular design allows for easy replacement and testing of individual components.



## **Conclusions.**

In addition to demonstrating useful electro-optic phase control, the obstacles of fabricating the phase controlling device were overcome. With the prototype system developed during the Phase I effort,  $\pi$  phase shifts were achieved with voltages as low as 30V and an average coupling efficiency of 50%. Thus, the Phase I effort not only demonstrated that electro-optic phase control is feasible, but it also demonstrated that the proposed technology can be efficiently coupled to a fiber array.

## DISTRIBUTION LIST

DTIC/OCP  
8725 John J. Kingman Rd, Suite 0944  
Ft Belvoir, VA 22060-6218 1 cy

AFSAA/SAMI  
1570 Air Force Pentagon  
Washington, DC 20330-1570 1 cy

AFRL/VSIL  
Kirtland AFB, NM 87117-5776 2 cys

AFRL/VSIH  
Kirtland AFB, NM 87117-5776 1 cy

AdvR, Inc.  
910 Technology Blvd., Suite K  
Bozeman, MT 59718 1 cy

Official Record Copy  
AFRL/DELO/Dr. Kenneth D. Shaw 2 cy