

UNITED STATES AIR FORCE RESEARCH LABORATORY



HIGH PERFORMANCE PAPER WHITE- AND FULL-COLOR REFLECTIVE DISPLAYS

Thomas F. Fiske
Jennifer Colegrove
Alan Lewis
H. Tran
Haiji Yuan
John Gunther
Gongjian Hu

dpiX LLC
3406 HILLVIEW AVENUE
PALO ALTO CA 94304

Louis D. Silverstein

VCD SCIENCES, INC.
9695 E. YUCCA STREET
SCOTTSDALE AZ 85260

Gregory P. Crawford
L.-C. Chein
Chris Bowley

BROWN UNIVERSITY
ENGINEERING DIVISION
PROVIDENCE RI 02912

Jack R. Kelly

KENT STATE UNIVERSITY
LIQUID CRYSTAL INSTITUTE
KENT OH 44242-0001

JUNE 2001

FINAL REPORT FOR THE PERIOD 13 SEPTEMBER 1996 TO 12 JUNE 1999

Approved for public release, distribution unlimited.

Human Effectiveness Directorate
Crew System Interface Division
2255 H Street
Wright-Patterson AFB, OH 45433-7022

20010905 093

NOTICES

When US Government drawings, specifications, or other data are used for any purpose other than a definitely related Government procurement operation, the Government thereby incurs no responsibility nor any obligation whatsoever, and the fact that the Government may have formulated, furnished, or in any way supplied the said drawings, specifications, or other data, is not to be regarded by implication or otherwise, as in any manner licensing the holder or any other person or corporation, or conveying any rights or permission to manufacture, use, or sell any patented invention that may in any way be related thereto.

Please do not request copies of this report from the Air Force Research Laboratory. Additional copies may be purchased from:

National Technical Information Service
5285 Port Royal Road
Springfield, Virginia 22161

Federal Government agencies and their contractors registered with the Defense Technical Information Center should direct requests for copies of this report to:

Defense Technical Information Center
8725 John J. Kingman Road, Suite 0944
Ft. Belvoir, Virginia 22060-6218

TECHNICAL REVIEW AND APPROVAL

AFRL-HE-WP-TR-2001-0099

This report has been reviewed by the Office of Public Affairs (PA) and is releasable to the National Technical Information Service (NTIS). At NTIS, it will be available to the general public.

This technical report has been reviewed and is approved for publication.

FOR THE COMMANDER

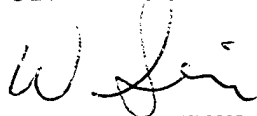

WILLIAM C. SIMON, Lt Col, USAF, BSC
Deputy Chief, Crew System Interface Division
Air Force Research Laboratory

REPORT DOCUMENTATION PAGE

Form Approved
OMB No. 0704-0188

Public reporting burden for this collection of information is estimated to average 1 hour per response, including the time for reviewing instructions, searching existing data sources, gathering and maintaining the data needed, and completing and reviewing the collection of information. Send comments regarding this burden estimate or any other aspect of this collection of information, including suggestions for reducing this burden, to Washington Headquarters Services, Directorate for Information Operations and Reports, 1215 Jefferson Davis Highway, Suite 1204, Arlington, VA 22202-4302, and to the Office of Management and Budget, Paperwork Reduction Project (0704-0188), Washington, DC 20503.

1. AGENCY USE ONLY (Leave blank)	2. REPORT DATE June 2001	3. REPORT TYPE AND DATES COVERED FINAL REPORT 13 September 1996 - 12 June 1999	
4. TITLE AND SUBTITLE HIGH PERFORMANCE PAPER-WHITE AND FULL-COLOR REFLECTIVE DISPLAYS		5. FUNDING NUMBERS C: F33615-96-2-1940 PE: 62708E PR: ARPA TA: AA WU: 13	
6. AUTHOR(S) *Thomas G. Fiske, Jennifer Colegrove, Alan Lewis, H. Tran, Haiji Yuan, John Gunther, Gongjian Hu; **Louis D. Silverstein; ***Gregory P. Crowdord, L.-C. Chein, Chris Bowley; **** Jack R. Kelly			
7. PERFORMING ORGANIZATION NAME(S) AND ADDRESS(ES) * dpiX LLC, 3406 Hillview Avenue, Palo Alto CA 94304 ** VCD Sciences, 9695 E. Yucca Street, Scottsdale AZ 85260 *** Brown University, Engineering Division, Providence RI 02912 **** Kent State University, Kent OH 44242-0001		8. PERFORMING ORGANIZATION	
9. SPONSORING/MONITORING AGENCY NAME(S) AND ADDRESS(ES) Air Force Research Laboratory Human Effectiveness Directorate Crew System Interface Division Air Force Materiel Command Wright-Patterson AFB OH 45433-7022		10. SPONSORING/MONITORING AFRL-HE-WP-TR-2001-0099	
11. SUPPLEMENTARY NOTES			
12a. DISTRIBUTION/AVAILABILITY STATEMENT Approved for public release, distribution is unlimited		12b. DISTRIBUTION CODE	
13. ABSTRACT (<i>Maximum 200 words</i>) This report documents work performed by a team led by dpiX LLC to develop fabrication technology for a paper-white, video-rate, full-color reflective display technology based on holographically formed polymer dispersed liquid crystal (HPDLC) displays. The fabrication of HPDLC devices was optimized with numerous controlled experiments and simulations. Proper materials selection in combination with fabrication process improvements enabled achievement of high peak reflectance and increased spectral reflectance bandwidth, which, together, yielded dramatic improvements in photopic reflectance. A novel method was proposed and tested to fabricate and model off-axis diffusely reflecting HPDLC cells with extended viewing angles. A method of stacking multiple HPDLC films between a single set of substrates was demonstrated, which allowed fabrication of white devices with increased photopic reflectance and broader reflective bandwidths. It was also demonstrated that HPDLC mirrors can be integrated into an electronic color image acquisition system to enhance color performance and decrease cost of video cameras.			
14. SUBJECT TERMS Full Color Reflective Display, Paper-White Display, Video-Rate, Viewability, Holographically Formed Polymer Dispersed Liquid Crystal			15. NUMBER OF PAGES 24
			16. PRICE CODE
17. SECURITY CLASSIFICATION OF REPORT Unclassified	18. SECURITY CLASSIFICATION OF THIS PAGE Unclassified	19. SECURITY CLASSIFICATION OF ABSTRACT Unclassified	20. LIMITATION OF ABSTRACT Unlimited

This Page Intentionally Left Blank

CONTENTS

ABSTRACT (SF 298).....	i
LIST OF FIGURES.....	iv
FOREWORD.....	v
PREFACE.....	vi
ACKNOWLEDGEMENTS.....	vi
1. SUMMARY.....	1
2. INTRODUCTION.....	2
3. METHODOLOGY AND GOALS.....	3
4. RESULTS AND DISCUSSION.....	4
5. CONCLUSIONS.....	12
6. RECOMMENDATIONS.....	12
7. LIST OF SYMBOLS, ABBREVIATIONS, AND ACRONYMS	14
APPENDICES	
A. LIST OF PUBLICATIONS RELATED TO THIS DARPA-SPONSORED PROGRAM	15
B. LIST OF PATENTS RELATED TO THIS DARPA-SPONSORED PROGRAM.....	17

LIST OF FIGURE CAPTIONS

- Figure 1.** Measured performance improvement in both the peak reflectance and photopic reflectance over the course of the program.....4
- Figure 2.** Measured spectra of dpiX' red, green, and blue HPDLCs, with reference to a perfect specular reflector as 100%.....5
- Figure 3.** Measured electro-optical performances of HPDLCs with different recipes and curing conditions for 4 micron thick cells.....6
- Figure 4.** Illustration of viewing angle extension for HPDLCs using our proprietary techniques in our experiments.....7
- Figure 5.** Examples of the measured spectra for a set of red, green, blue HPDLCs that offers excellent color gamut and balanced white point.....8
- Figure 6.** Measured chromaticity coordinates for dpiX's red, green, and blue HPDLCs, and dpiX's demonstration display, compared to that of a color CRT with a standard P22 phosphor set, and state-of-art commercial color reflective LCD from Sharp used in their color PDA Zaurus.....9
- Figure 7.** Measured electro-optic response of an HPDLC sample. Fast switching speeds of $\tau_{on} = 0.750$ ms and $\tau_{off} = 0.08$ ms have been measured for this sample.....10
- Figure 8.** SEM Micrographs of an HPDLC at 30kX (left) and at 43kX (right).....11
- Figure 9.** SEM Micrographs of an HPDLC at 65kX (left) and at 35kX (right).....11

FOREWORD

This Cooperative Agreement No. F33615-96-2-1940 was selected under Defense Advanced Research Projects Agency (DARPA) Broad Agency Announcement (BAA) 97-42, entitled "High Definition Systems." This Cooperative Agreement between the government and dpiX LLC required each to provide 50% of the total project funding level of \$5.5M over 33 months from 13 September 1996 through 12 June 1999. The government share of the funding, \$2.75M was provided by DARPA. The Cooperative Agreement was managed by the Air Force Research Laboratory as DARPA Agent.

VCD Sciences Inc. was a subcontractor to dpiX to provide expertise on ambient light management and optical modeling, both for reflective displays.

Brown University was a sub-contractor to dpiX under this DARPA supported program to develop new materials formulations. The subcontract fully supported Christopher Bowley who was a graduate student under Prof. Greg Crawford. The university-industry collaboration was very beneficial to both parties. Christopher Bowley was awarded an Society for Information Display (SID) Graduate Student travel award to attend the SID Symposium in San Jose, May 1999, and present the paper entitled *Electro-optic Investigations of H-PDLCs: The effect of Monomer Functionality on Display Performance*. He was also awarded a Materials Research Society (MRS) Graduate Student Gold Medal Award at the MRS Spring Meeting in San Francisco, April 1999, for his DARPA funded holographically-formed polymer dispersed liquid crystal (HPDLC) research.

dpiX LLC also worked very closely with the Liquid Crystal Institute (LCI) at Kent State University, and supported the PhD graduate student, Jenny Colegrove from LCI working under Prof. Jack Kelly, to work on the HPDLCs full time. She has presented at the SPIE AeroSense'99 in April and was commended by audiences as one of the best presentations at the conference.

It is clear that both the display community and the materials community have a lot of interest in the R&D work dpiX LLC has carried out so far, including AFRL/MLPJ.

A detailed list of journal and proceedings publications reporting work accomplished under this DARPA-sponsored Cooperative Agreement is provided in Appendix. A. A similar list of patents is provided in Appendix B.

This report was assembled, formatted, and edited by Dr. Darrel G. Hopper of the Air Force Research Laboratory in his role as DARPA Agent based on materials from several sources, mainly the final quarterly report from dpiX dated 30 July 1999 and other dpiX material, with additions to the front matter and appendix sections where necessary for completeness.

A color version of this report is available upon request from AFRL/HECV, 2255 H Street, Building 248, Wright Patterson AFB OH 45433-7022.

PREFACE

The purpose of this effort was to develop a color, low-power, reflective liquid crystal display. Unlike conventional liquid crystal displays, the reflective display technology does not require backlighting which makes it very attractive in portable display applications where power conservation is critical. The illustration below shows the reduction in power consumption with typical numbers when the backlight is eliminated. The work involved development of polymer dispersed liquid crystal (PDLC) materials and cell structures via interferometric processes. Holographically formed PDLC (HPDLC) material is compatible with active matrix addressing as a future pathway to high resolution. The HPDLC material is unique among reflective display technologies in providing video rate potential in a low power device. Image quality possible with HPDLC material can enable practical full-color reflective mode displays.

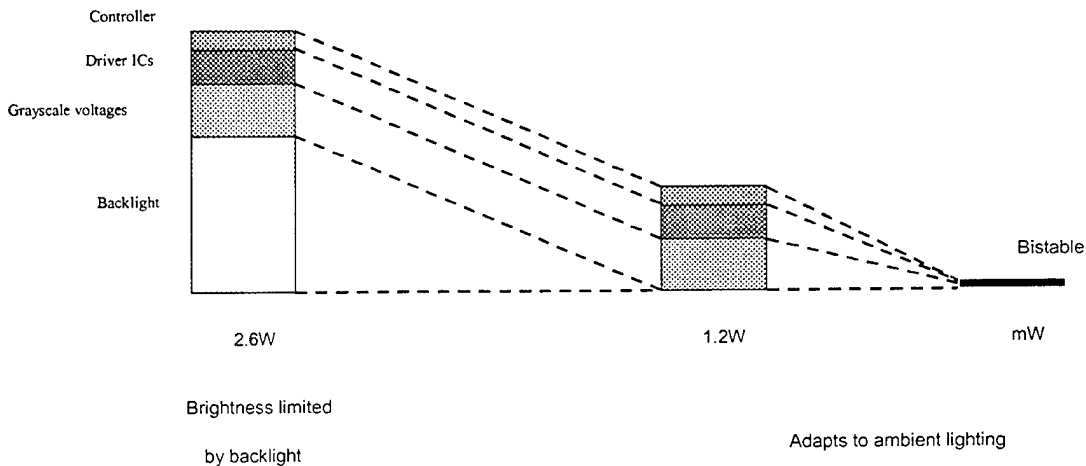
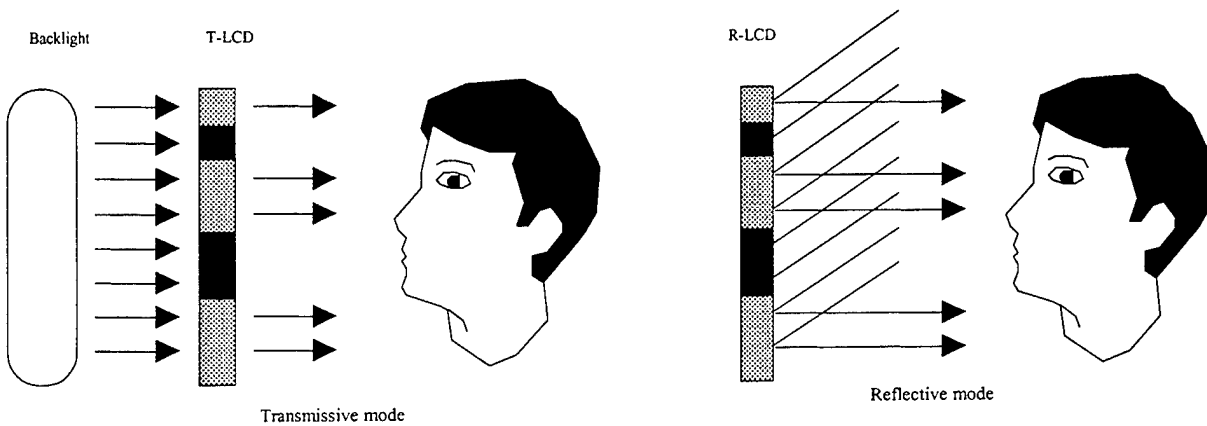

ACKNOWLEDGEMENTS

We gratefully acknowledge the partial financial support from the Defense Advanced Research Projects Agency (DARPA) under Cooperative Agreement Number F33615-96-2-1940. We thank the Air Force DARPA Agent, Dr. Darrel Hopper, and grant monitor, Mr. Frederick Meyer, of the Air Force Research Laboratory (AFRL) for their support throughout the project.

1. SUMMARY

This program has focused primarily upon fundamental materials and cell structure development of holographically formed polymer dispersed liquid crystals (HPDLCs) for reflective display applications. The main achievements include the following:

- * Achieved over four times brighter reflective HPDLC displays during effort (see Figure 1).
- * Demonstration of HPDLC cells with over 75% peak reflectance (see Figure 2).
- * Development and demonstration of materials packages with reduced drive voltages (V₉₀ from over 300 V to less than 50 V) (see Figure 3).
- * Demonstration of HPDLCs with extended viewing angles without surface glare and back scattering (see Figure 4).
- * Development of novel techniques for adjusting the color of HPDLC cells through the adjustment of the curing system. This allows less material handling and better electro-optic curve uniformity for all colors (see Figure 2).
- * Demonstration of fully tunable reflected wavelengths through blue, green, and red spectra from 450 nm to 650 nm (see Figure 2).
- * Demonstration of the widest color gamut ever published for reflective displays (see Figures 5 and 6). The chromaticities of individual R,G, B HPDLC cells are highly saturated and while some loss in saturation is observed in a prototype stacked display, the gamut remains the largest reported for a reflective display. Improvements in stacking techniques and HPDLC cells are expected to allow the stacked structure to approach the performance of the individual cells more closely.
- * Achieved sub-millisecond switching, faster than needed for video applications (see Figure 7).
- * Completion of preliminary design and simulations of high voltage active matrix for HPDLC reflective displays.
- * Successfully used scanning electron micrographs (SEMs) to monitor and modify HPDLCs for better optical and electro-optical performances (see Figures 8 and 9).

In addition, models and simulation tools were developed for HPDLC design.

2. INTRODUCTION

2.1 Overview

This report documents work performed by a team led by dpiX LLC to develop fabrication technology for a paper-white, video-rate, full-color reflective display technology based on holographically formed polymer dispersed liquid crystal (HPDLC) displays. It was also demonstrated that HPDLC mirrors can be integrated into an electronic color image acquisition system to enhance color performance and decrease cost of video cameras.

2.2 Fabrication, Operation, Design Trades

An HPDLC device is formed by polymerizing a thin mixture of monomer and liquid crystal (LC) materials to form a permanent interference pattern. Polymerization in the planes of constructive interference of two laser beams (light layers during exposure) forces the LC material to separate into droplets in the planes of destructive interference (dark layers during exposure). The laser wavelength and exposure geometry determines the pitch of the resulting LC layers. The resulting layered structure of polymer-rich layers and liquid crystal-rich layers gives rise to an optical index modulation which gives Bragg reflection. Illumination of the resulting device with incoherent light results in reflection from the layers in accordance with the Bragg reflection model. If the layers are formed roughly parallel (perpendicular) to the substrate the resulting device is a reflective display (notched transmission filter). A 10° diffuser is (not) placed in one laser beam during exposure for diffuse (specular) samples. HPDLC material typically is 4-8 μm thick comprising alternating pairs of polymer and LC layers on a pitch of about 200 nm.

The liquid crystal material within the droplets has an isotropic distribution so that with no field applied the display is normally in the reflective state. When an electric field is applied the director of the LC material aligns parallel to the field (for an LC material with a positive dielectric anisotropy). With the proper choice of material parameters, the index modulation is thereby reduced or eliminated in the layered structure which then produces a transmissive state, and arriving light passes to the black absorbing layer on the back of the display. This type of display is "normally white." The electric field is applied as AC rather than just DC to avoid "burn-in" as some LC molecules would become attached in a permanent alignment under a permanent field.

There is a trade-off in HPDLC device design between reflectivity and switching speed. The number of Bragg layers is directly related to the reflectivity and wavelength selectivity (both highly desirable) but is also directly related to the switching voltage required (highly undesirable). The efficiency of the individual Bragg layers (LC layers) also determines the number required. Surfactants in the LC material lower the attachment energy at the LC-polymer boundary, lower operational voltage, and increase switching speed (1ms on, 2-15 ms off).

2.3 Applications

Theoretically, an HPDLC display might have the following properties—simultaneously: (1) readable in all ambient lighting conditions with a minimum contrast ratio of 2:1; (2) able to match print magazine image quality by providing essentially unlimited gray scale and color; (3) scalable in size at both the display and pixel level; (4) capable of full motion video rate

(combined on/off times are typically 3 ms for green, 14 ms for blue, and 15 ms for red); (5) portable due to low power via reflective operation using ambient illumination where available; and (6) able to become a flexible display on plastic or thin steel substrate inherently resistant to breakage. The HPDLC is, theoretically, the panacea for direct view mobile and vehicle display applications. Miniature versions might eventually be used in projection displays.

Electronic shutters for windows based on PDLC material have been commercialized. Thus, a product base already exists to support some aspects of the development of more complex PDLC devices such as displays based on HPDLC structures.

Technology challenges for HPDLC include reducing the drive voltage required (now 90 V) and decreasing the pixel size (now about 1 mm) in test samples to create high information content displays. Large pixels may find application in jumbo displays.

3. METHODOLOGY AND GOALS

The methodology was to initiate and iteratively improve processes, materials, recipes, and display performance of HPLCD devices. Key performance parameters—such as reflectance, driving voltage, contrast ratio, viewing angle, and color saturation—were to be simultaneously optimized from focused efforts. Holographic techniques for forming PDLC displays were to be optimized. During the effort a novel method was proposed and tested to fabricate and model off-axis diffusely reflecting HPDLC cells with extended viewing angles.

The fabrication of HPDLC devices was optimized with numerous controlled experiments and simulations. Proper materials selection in combination with fabrication process improvements was expected to enable achievement of high peak reflectance and increased spectral reflectance bandwidth, which, together, would yield dramatic improvements in photopic reflectance.

Paper-white HPDLC display material systems were developed by first developing separate monochrome red, green, and blue panels, and then, white panels. The materials to be examined were to offer superior reflectivity and contrast ratio, and retain the response speed necessary for video reproduction. It was understood that these cells were likely to require a more complex high voltage active matrix array for addressing.

Color gamut and white reflectance were to be examined for full color HPDLC devices. Addressing schemes were to be considered in designing the test structures.

An evaluation was to be made of the engineering and manufacturing issues associated with the future development of a high resolution version of a HPDLC display.

A method of stacking multiple HPDLC films between a single set of substrates was to be demonstrated to allow fabrication of white devices with increased photopic reflectance and broader reflective bandwidths.

4. RESULTS AND DISCUSSION

A list of journal and proceedings publications reporting work accomplished under this DARPA-sponsored Cooperative Agreement in additional detail is provided in Appendix A.

4.1 Performance Improvement in Reflectance

Figure 1 shows the improvement in both the peak reflectance and photopic reflectance over the course of the program. As can be seen from Figure 1, the progress has been rapid and the gain in brightness is more than four times over a period of two years. The brightness within the viewing cone (which can be tailored for specific applications, see below for more details) that was achieved is typically several times brighter than what is available commercially today.

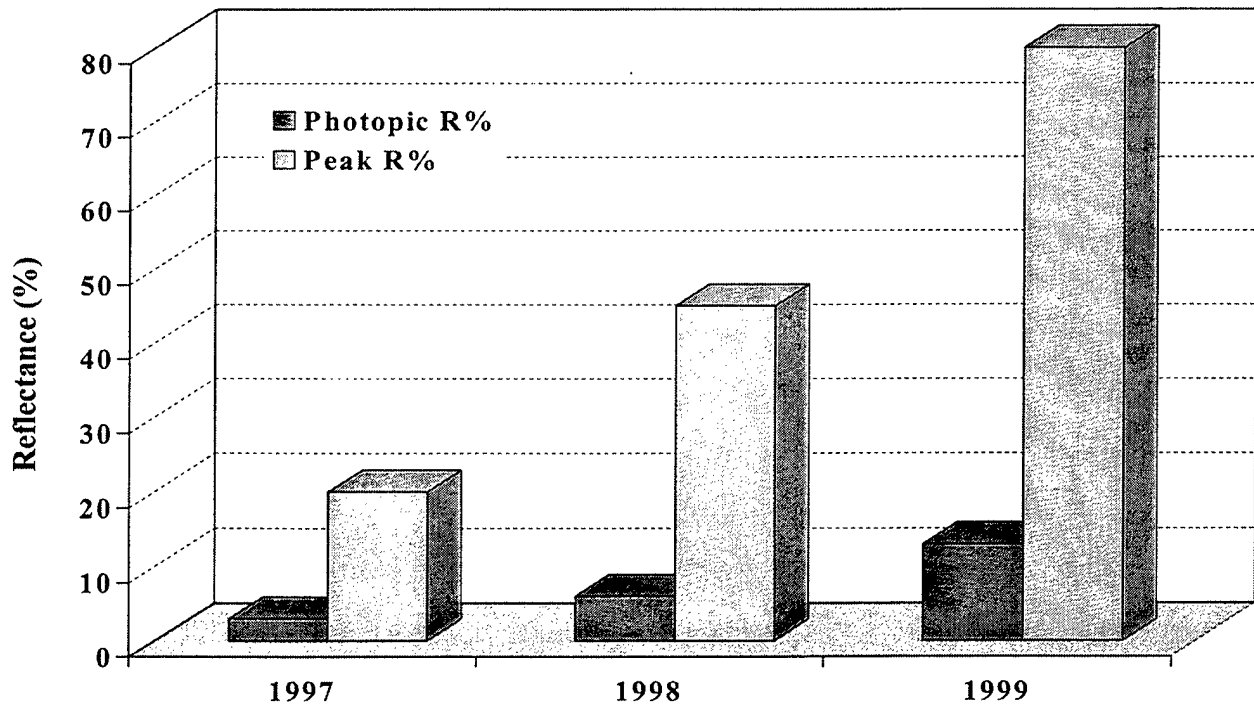

Figure 1. Measured performance improvement in both the peak reflectance and photopic reflectance over the course of the program.

The significant improvements in reflectance have been achieved through focused efforts in both process and materials improvements during the course of the program. The efforts have resulted in robust HPDLC fabrication setups, processes, and many new mixtures that are suitable for highly reflective HPDLC displays. For each new material or recipe, extensive optimizations were carried out by preparing the mixtures with different concentrations and curing them with different conditions. Figure 2 shows some examples of the reflection spectra measured from the HPDLC displays made through the program, including some old and relatively new ones.

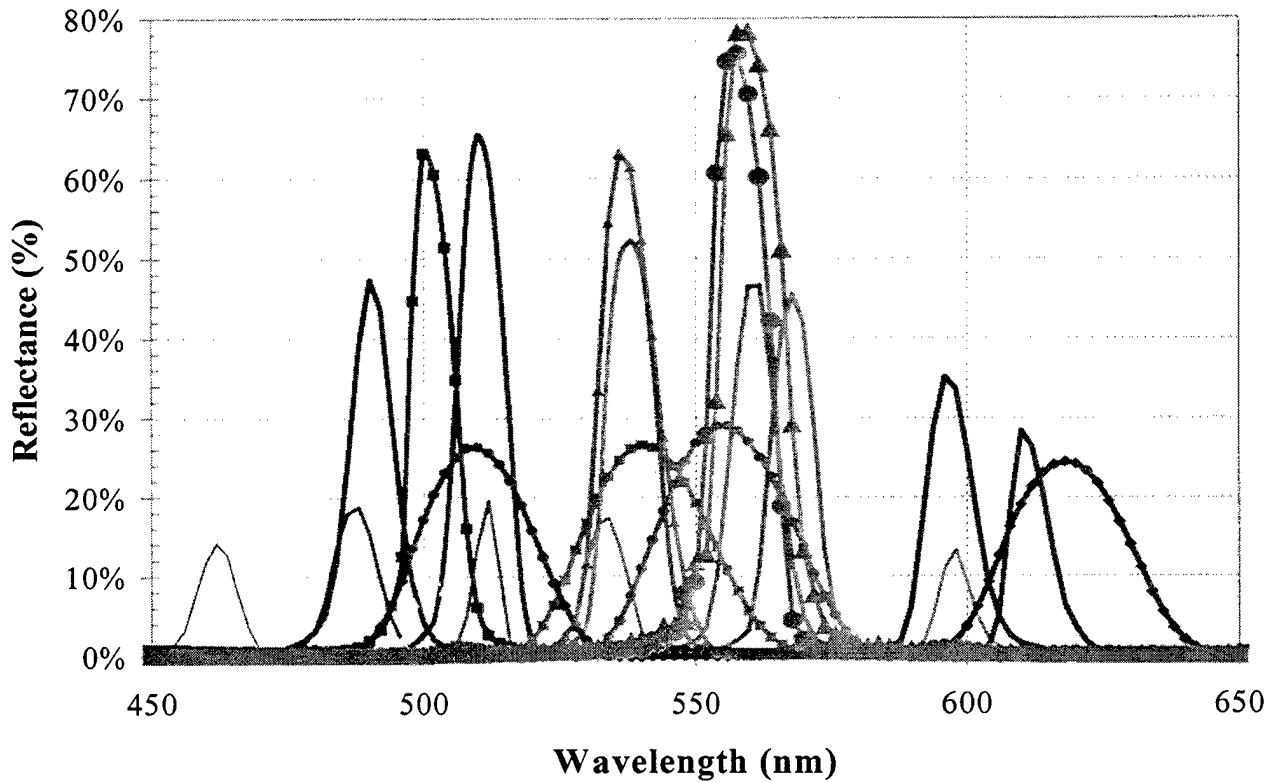

Figure 2. Measured spectra of dpiX red, green, and blue HPDLCs, with reference to a perfect specular reflector as 100%.

4.2 Performance Improvement in Driving Voltage and Contrast Ratio

Efforts have been made through materials search, recipe formulation, and fabrication process changes to reduce the driving voltage and increase contrast ratio. Figure 3 summarizes the measured electro-optical performances of HPDLCs with different recipes and curing conditions for 4 μm thick cells. First, the selections of right LC and polymer materials helped to lower the driving voltage V_{90} from 80 $\text{V}/\mu\text{m}$ to 40 $\text{V}/\mu\text{m}$; then the addition of right surfactants has further reduced V_{90} down to $\sim 10 \text{ V}/\mu\text{m}$ as shown in Figure 3. Further reduction in V_{90} is expected with continued efforts in these two directions. It is clear from Figure 3 that the high contrast ratio of greater than 50:1, which is several times higher than the commercially available reflective LCDs today, has been achieved through efforts during the course of the program.

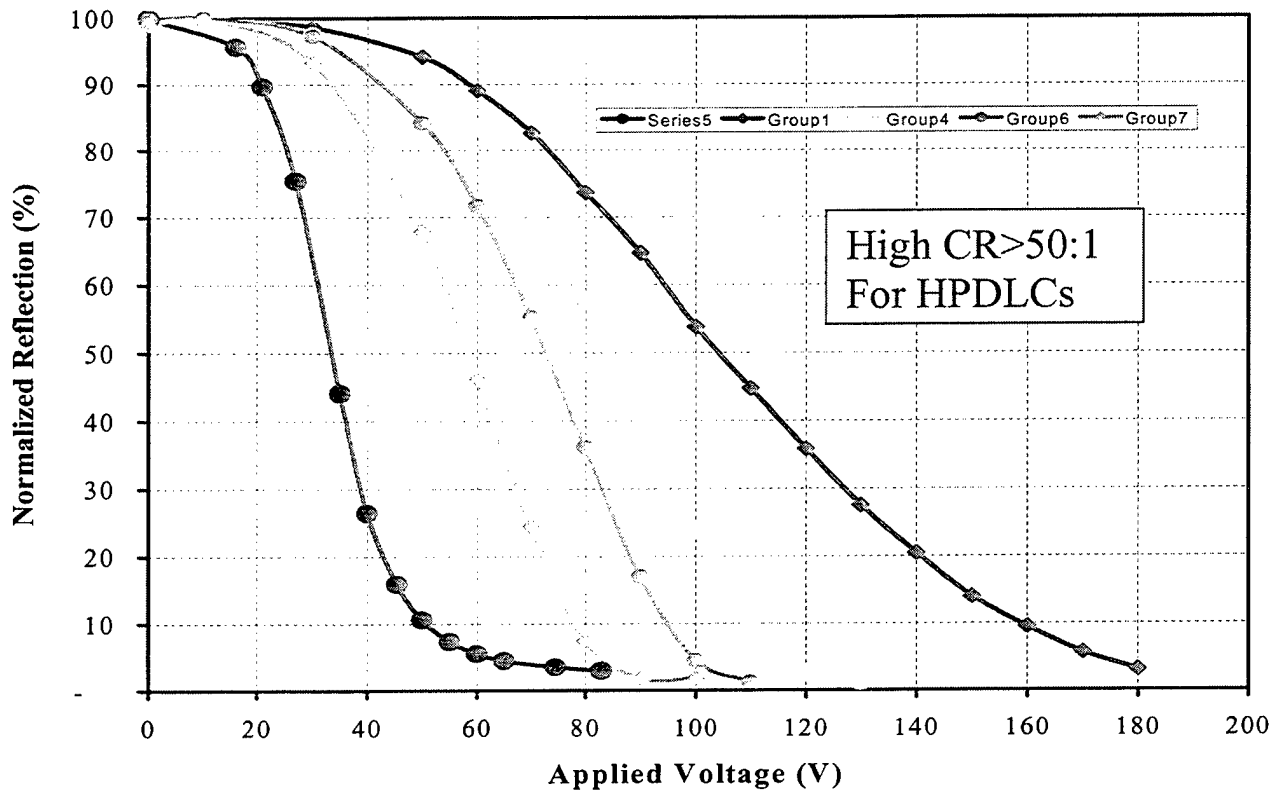

Figure 3. Measured electro-optical performances of HPDLCs with different recipes and curing conditions for 4 μm thick cells.

4.3 Performance Improvement in Viewing Angle

Typically speaking, standard HPDLCs have very high specular reflectance once right materials and process are used. However, standard HPDLCs also have very narrow viewing angle because they are based on the multi-layer Bragg reflection principle. Efforts have been made through dpiX proprietary fabrication techniques to improve the viewing angle of HPDLCs during this program. The proprietary techniques enable the viewing angle to be tailored for specific applications—a useful feature. In some applications, such as personal digital assistants (PDAs), the priority for large viewing angle is low, and the dpiX approach offers relatively narrow angle with rather concentrated distribution of the available light (high gain reflection). In other applications, such as electronic maps, the dpiX approach offers large area and multiple users the relative large viewing angle they require. Figure 4 shows one example of such viewing angle extension for HPDLCs in these experiments.

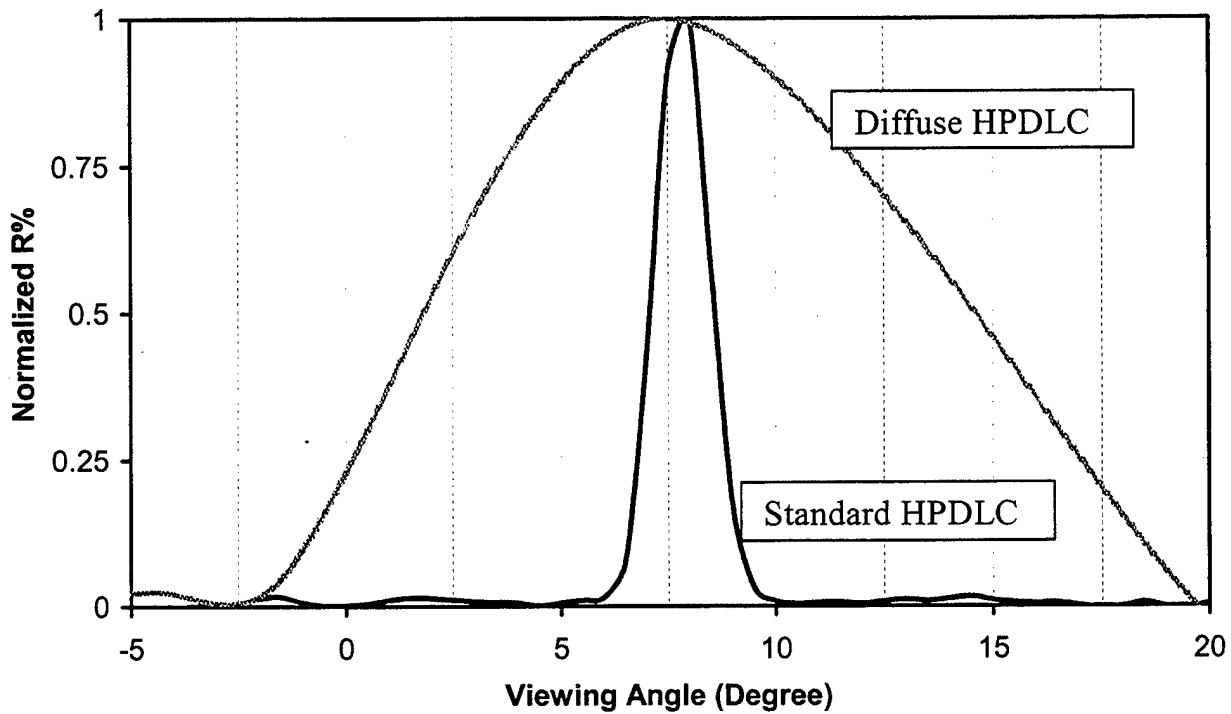

Figure 4. Illustration of viewing angle extension for HPDLCs using proprietary techniques in the dpiX experiments.

4.4 Performance Improvement in Color Saturation

Individual HPDLCs offer excellent color saturation at specific colors predetermined through laser curing setup and materials selections. To produce multi-color or full-color reflective LCDs, several layers of HPDLCs are needed. In addition, to achieve a balanced white point, peak wavelengths of these layers and their reflectance have to be chosen correctly. Numerous computer simulations and stacking experiments have been carried out to achieve full-color displays with excellent color gamut and balanced white point. Figure 5 shows an example of the measured spectra of a set of red, green, and blue HPDLCs that offers such requirements. Additional care has also been taken to minimize the scattering from each HPDLC layer and the interface reflections between sub-layers, which could reduce the color saturation. The end result of these numerous efforts is a full-color HPDLC reflective display with the widest color gamut ever reported.

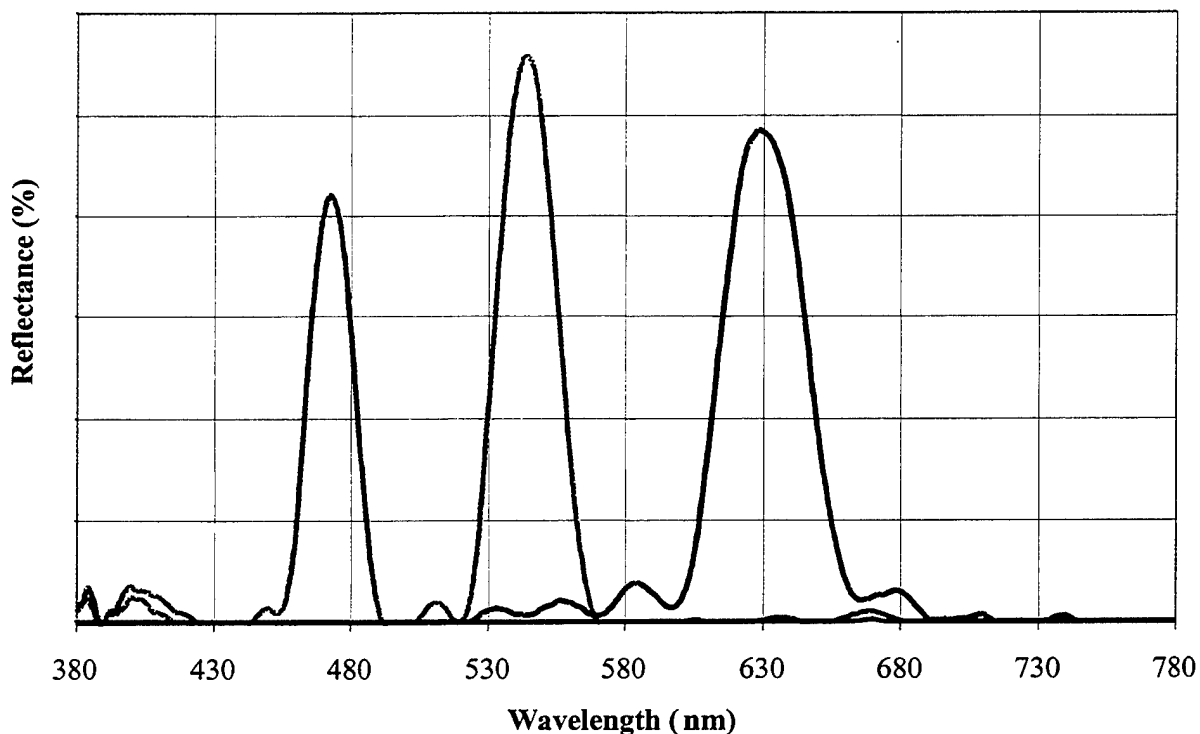

Figure 5. Examples of the measured spectra for a set of red, green, and blue HPDLCs that offers an excellent color gamut and a balanced white point.

Figure 6 shows the measured chromaticity coordinates for dpiX's red, green, and blue HPDLCs, and dpiX's demonstration display, compared to that of a color CRT with a standard P22 phosphor set at the optimum condition, and a state-of-the-art commercial color reflective LCD from Sharp used in their color PDA Zaurus. The dpiX HPDLC color display demo shows a much wider color gamut than the state-of-the-art commercially available color reflective displays.

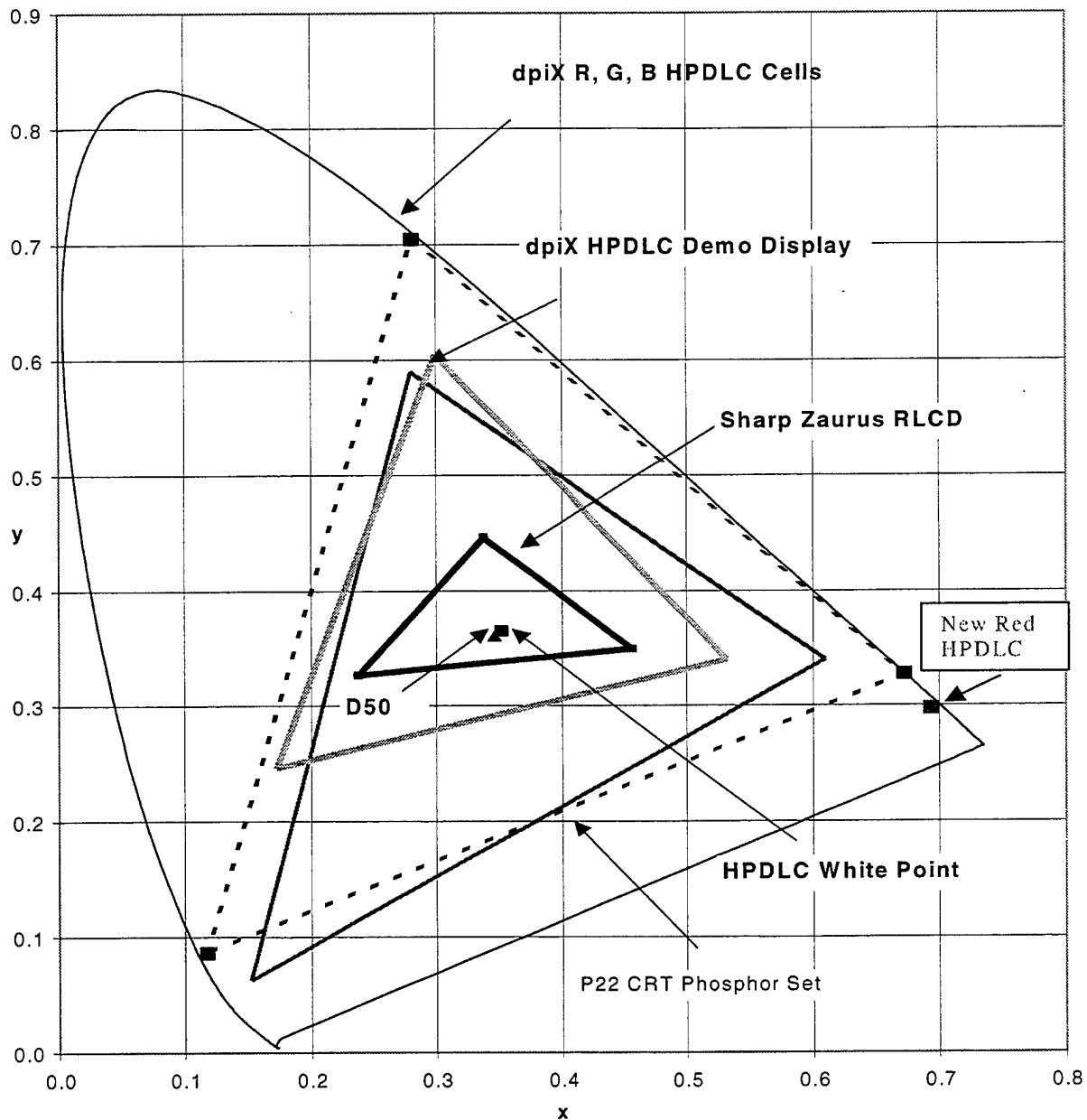

Figure 6. Measured chromaticity coordinates for dpiX's red, green, and blue HPDLCs and the dpiX demonstration display, compared to that of a color CRT with a standard P22 phosphor set, and a state-of-the-art commercial color reflective LCD from Sharp used in their color PDA Zaurus.

4.5 Measured Fast Switching Times and Scanning Electron Micrograph Pictures

In addition to reflectance, transmittance, and absorption measurements, the switching behaviors of these new HPDLC cells were also measured. Figure 7 shows an example of such measurement. The oscilloscope trace shows very fast sub-millisecond turn-ON and turn-OFF times for these higher efficiency HPDLCs.

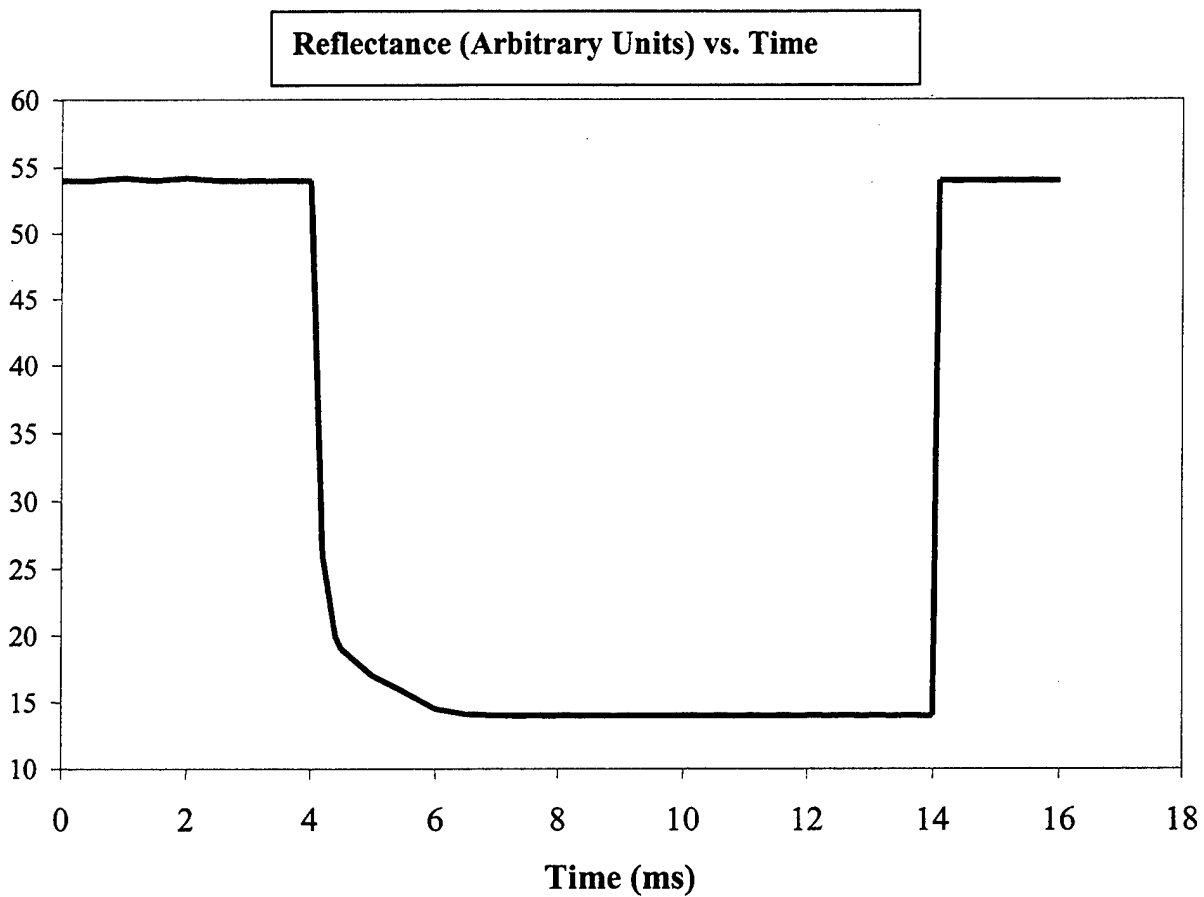

Figure 7. Measured electro-optic response of an HPDLC sample. Fast switching speeds of $\tau_{on} = 0.75$ ms and $\tau_{off} = 0.08$ ms have been measured for this HPDLC sample.

During the course of this program numerous SEM pictures were taken to help understand the morphologies of the HPDLCs fabricated, and to correlate them to optical and electro-optical performance. Figures 8 and 9 show some examples of such SEM pictures. The Bragg layered structure of alternating LC-rich layers (filled with dark cavities in the SEM pictures) and polymer-rich layers (filled with brighter colored polymers in the SEM pictures) is very evident.

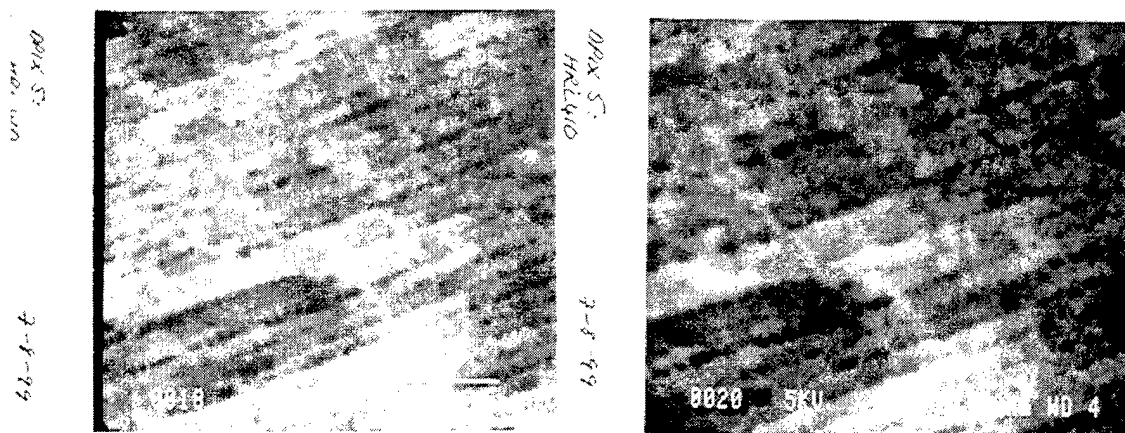

Figure 8. SEM Micrographs of an HPDLC at 30kX (left) and at 43kX (right).

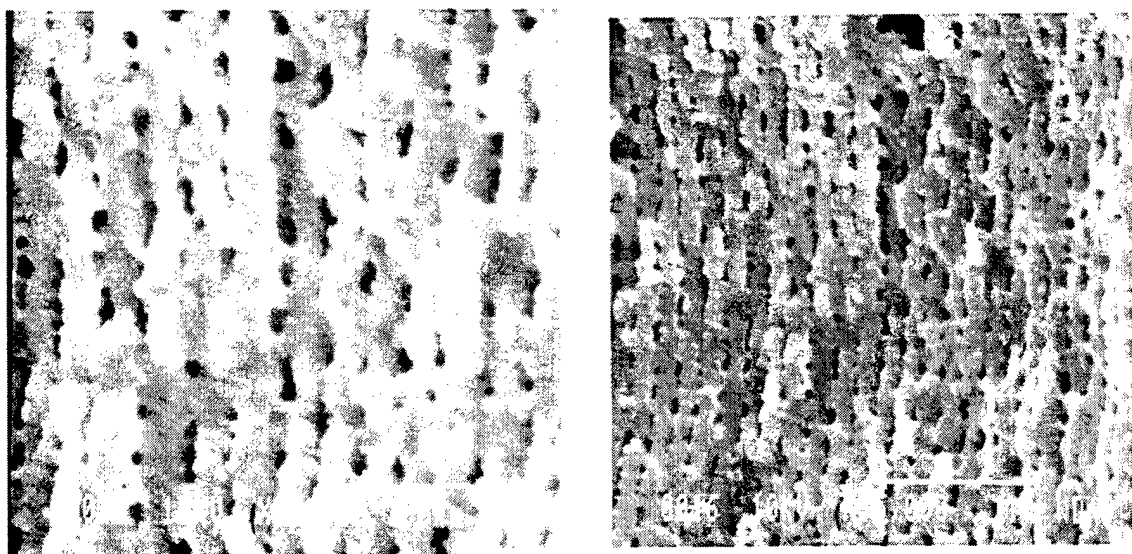

Figure 9. SEM Micrographs of an HPDLC at 65kX (left) and at 35kX (right).

5. CONCLUSIONS

The fabrication of HPDLC devices was optimized with numerous controlled experiments and simulations. Proper materials selection, in combination with fabrication process improvements, enabled achievement of high peak reflectance and increased spectral reflectance bandwidth, which together, yielded dramatic improvements in photopic reflectance. A novel method was proposed and tested to fabricate and model off-axis diffusely reflecting HPDLC cells with extended viewing angles. A method of stacking multiple HPDLC films between a single set of substrates was developed, which allowed fabrication of white devices with increased photopic reflectance and broader reflective bandwidths. It was also demonstrated that HPDLC mirrors can be integrated into an electronic color image acquisition system to enhance color performance and decrease cost of video cameras.

6. RECOMMENDATIONS

Future steps needed to realize a viable display technology include the following: (a) the further increase of HPDLC reflection efficiency and viewing angles, (b) the fabrication of HPDLC displays with active matrix backplanes; and (c) the demonstration of HPDLC displays on flexible substrates. Specific recommendations are as follows:

6.1 Increase Viewing Cone

Efforts need to be focused on the integration of the holographic diffusing structures with the holographically formed HPDLC structure. The basic concept has been successfully demonstrated (see Figure 4) and the recommended effort would concentrate on improving the efficiency of the system and exploring the trade off between viewing angle, photopic reflectance, and subjective viewability. For example, in a hand held device, one tends to adjust one's viewing angle for maximum visibility; simply broadening the viewing angle at the expense of other display characteristics is not necessarily the best trade-off. On the other hand, increased viewing cone is definitely a requirement for a large display to show uniform performance across the whole display.

6.2 Develop Coating Techniques

HPDLC materials are inherently mechanically stable and need not depend on a supporting substrate to maintain their structure. In this sense, they are similar to PDLC materials, and this characteristic supports formation of large area displays. However, in order to achieve this, coating techniques must be developed. It is recommended that several approaches be explored, including blade and roller coating techniques. A manual coater could be used for this purpose. Coating process development might include, for example, establishing suitable wetting techniques and optimization of the HPDLC recipe for coating.

6.3 Develop New Exposure Methods

One of the limitations of current HPDLC fabrication techniques, in which the whole display is exposed to the laser at the same time, is the extension to larger displays. If the laser beam is enlarged, exposure times either become very long (making it difficult to maintain coherence stability) or the required laser power becomes impractical. An alternative approach is recommended for investigation: namely, the use of linearly-expanded laser beams and movement of the substrate during laser exposure for large area displays.

6.4 Formation of HPDLC Displays of Thin and Flexible Substrates

The formation of HPDLC layers on very thin glass and flexible plastic substrates should be investigated. Issues that must be resolved include, for example, maintaining adequate mechanical rigidity and uniform HPDLC film thickness during exposure.

6.5 Develop Transfer Techniques

One attractive approach for fabricating large area HPDLC displays on either flexible or rigid substrates, or for building stacked HPDLC structures, is to transfer HPDLC sheets from a formation substrate to the final display.

6.6 HPDLC Materials and Process Development

Development and optimization of monomer initiator liquid crystal systems for improved reflectance and reduced drive voltage should continue.

7. LIST OF SYMBOLS, ABBREVIATIONS, AND ACRONYMS

AC	Alternating current
AFRL	Air Force Research Laboratory
BAA	Broad Agency Announcement
CR	Contrast ratio
CRT	Cathode ray tube
DARPA	Defense Advanced Research Projects Agency
DC	Direct Current
HDS	High Definition Systems
HPDLC	Holographically formed polymer dispersed liquid crystal
LC	Liquid crystal
LCD	Liquid crystal display
LCI	Liquid Crystal Institute (of Kent State University)
MRS	Materials Research Society
PDA	Personal digital assistant
PDLC	Polymer dispersed liquid crystal
RGB	Red, Green, Blue
SEM	Scanning electron micrograph
SPIE	International Society for Optical Engineering (previously known as Society of Photo-Optical Instrumentation Engineers)
V	Volt
V90	Voltage that reduces reflectance to 10% of its initial value under zero voltage

APPENDIX A.

LIST OF PUBLICATIONS RELATED TO THIS DARPA-SPONSORED PROGRAM

1. "The Effect of Monomer Functionality on HPDLC Performance and Aging," J. Colegrove, T. Fiske, A. Lewis, H. Yuan, C. Bowley, G.P. Crawford, J. Kelly, and L. Silverstein, *2001 SID International Symposium Digest of Technical Papers*, Volume XXXII, pp. 962-965 (2001).
2. "Expanded viewing-angle reflection from diffuse holographic-polymer dispersed liquid crystal films," M. J. Escuti, P. Kossyrev, G.P. Crawford, T.G. Fiske, J. Colegrove, and L.D. Silverstein, *Applied Physics Letters*, 77 (26), pp. 4262-4264 (December 2000).
3. "Diffuse H-PDLC Reflective Displays: An Enhanced Viewing-angle Approach," M.J. Escuti, P. Kossyrev, C.C. Bowley, S. Danworaphong, G.P. Crawford, T.G. Fiske, J. Colegrove, L.D. Silverstein, A. Lewis, and H. Yuan, *2000 SID International Symposium Digest of Technical Papers*, Volume XXXI, pp. 766-773 (2000).
4. "Technology of stacking HPDLC for Higher Reflectance," J. Colegrove, J.R. Kelly, T. Fiske, A. Lewis, H. Yuan, H. Tran, G.P. Crawford, and L.D. Silverstein, *2000 SID International Symposium Digest of Technical Papers*, Volume XXXI, pp. 770-773 (2000).
5. "H-PDLC Color Separation Device for Image Capture Systems," T.G. Fiske, L.D. Silverstein, J. Colegrove, and H. Yuan, *2000 SID International Symposium Digest of Technical Papers*, Volume XXXI, pp. 1134-1137 (2000).
6. "Advances and applications for color HPDLC reflective technologies," T. Fiske, J. Colegrove, A. Lewis, H. Tran, L. Silverstein, G.P. Crawford, J.R. Kelly, in *Cockpit Displays VII: Displays for Defense Applications*, Proceedings of SPIE, Volume 4022, pp. 105-109 (2000).
7. "Improving the Voltage Response of Holographically Formed Polymer Dispersed Liquid Crystals (H-PDLCs)," submitted to *Molecular Crystals and Liquid Crystals*, C. C. Bowley, P. Kossyrev, S. Danworaphong, J. Colegrove, J. Kelly, T. Fiske, H. Yuan, and G. P. Crawford, (to be published).
8. "Drive-Voltage Reduction for HPDLC Displays," J. Colegrove, H. Yuan, T. Fiske, S.-T. Wu, J.R. Kelly, C. Bowley and G.P. Crawford, *Proceedings of the International Display Workshop(IDW'99)*, pp. 105-109 in Shendai, Japan (December 1999).
9. "Electro-Optic Investigations of H-PDLCs: The Effect of Monomer Functionality on Display Performance," C. C. Bowley, A. K. Fontecchio, G. P. Crawford, and H. Yuan, *1999 SID International Symposium Digest of Technical Papers*, Volume XXX, 958-961 (1999).

10. "HPDLC color reflective displays," H. Yuan, J. Colegrove, G. Hu, T. Fiske, A. Lewis, J. Gunther, L. Silverstein, C. Bowley, G. Crawford, L. Chien, and J. Kelly, in *Cockpit Displays VI: Displays for Defense Applications*, Proceedings of SPIE, Volume 3690, pp. 196-216 (1999).
11. "Reflection from dual-domains in a holographically-formed polymer-dispersed liquid crystal material," Chris C. Bowley, Gregory P. Crawford, and H. Yuan, *Appl. Phys. Lett.*, Volume 74, Number 21, pp. 3096-3098 (1999).
12. "Effect of Monomer Functionality on Performance of Holographically-formed Polymer Dispersed Liquid Crystals," A. K. Fontecchio, C. C. Bowley, and G. P. Crawford, *Molecular Crystals and Liquid Crystals* (1999).
13. "Advances in Holographic Polymer Dispersed Liquid Crystal Technology," C. C. Bowley, A. K. Fontecchio, J. J. Lin, H. Yuan, and G. P. Crawford, *MRS Symposium Proceedings*, p. 559 (1999).
14. "High Efficiency Color Reflective Displays with Extended Viewing Angle," H. Yuan, G. Hu, T. Fiske, A. Lewis, J. E. Gunther, L. D. Silverstein, C. Bowley, G. P. Crawford, L.-C. Chien, and J. R. Kelly, *Proceedings of the 18th International Display Research Conference*, p. 1135 (1998).
15. "Dual-domain Reflection from Holographically-formed PDLCs," C. C. Bowley, H. Yuan, and G. P. Crawford, *Proceedings of the 18th International Display Research Conference*, p. 851 (1998).
16. "Morphology of Holographically-formed Polymer Dispersed Liquid Crystals (H-PDLC)," Chris C. Bowley, Haiji Yuan, and Gregory P. Crawford, *Molecular Crystals and Liquid Crystals* (1998).

APPENDIX B.

LIST OF PATENTS RELATED TO THIS DARPA-SPONSORED PROGRAM

"Holographically formed reflective display, liquid crystal display and projection system and methods of forming the same"

Inventors: Silverstein, Louis D. (Scottsdale, AZ), Fiske, Thomas G. (Campbell, CA); Crawford, Greg P. (Providence, RI);

Assignee: Xerox Corporation (Stamford, CT)

Application No. 792268 filed January 31, 1997

US Patent 6,133,971 issued October 17, 2000

"Broadband reflective display, and methods of forming the same"

Inventors: Crawford, Greg P. (Providence, RI); Fiske, Thomas G. (Campbell, CA); Silverstein, Louis D. (Scottsdale, AZ)

Assignee: Xerox Corporation (Stamford, CT)

Application No. 792269 filed January 31, 1997

US Patent 5,875,012 issued February 23, 1999

"Paper-white reflective display and methods of forming the same"

Inventors: Crawford, Greg P. (Providence, RI); Fiske, Thomas G. (Campbell, CA); Silverstein, Louis D. (Scottsdale, AZ)

Assignee: Xerox Corporation (Stamford, CT)

Application No. 792307 filed January 31, 1997

US Patent 6,130,732 issued October 10, 2000

"Solid-state image capture system including H-PDLC color separation element"

Inventors: Silverstein, Louis D. (Scottsdale, AZ), Fiske, Thomas G. (Campbell, CA); Haiji Yuan, Haiji (Cupertino, CA);

Assignee: Xerox Corporation (Stamford, CT)

Application No. 221995 filed December 29, 1998

US Patent 6,166,800 issued December 26, 2000

"HPDLC devices with optical power"

Inventors: Colegrove, Jennifer K. (Mountain View, CA); Fiske, Thomas G. (Campbell, CA); Tran, Hanh (San Jose, CA); Silverstein, Louis D. (Scottsdale, AZ)

Assignee: dpiX LLC (Palo Alto, CA)

US Patent Application No. 09/571,749 filed May 15, 2000

"Novel technology of stacking HPDLC for higher reflectance"

Inventors: Colegrove, Jennifer K. (Mountain View, CA); Fiske, Thomas G. (Campbell, CA); Tran, Hanh (San Jose, CA); Crawford, Greg P. (Providence, RI); Silverstein, Louis D. (Scottsdale, AZ)

(Scottsdale, AZ)

Assignee: dpiX LLC (Palo Alto, CA)

US Patent Application #09/571,581 filed May 15, 2000

"Liquid crystal display device incorporating an active holographic translector"

Inventors: Silverstein, Louis D. (Scottsdale, AZ); Fiske, Thomas G. (Campbell, CA); Colegrove, Jennifer K. (Mountain View, CA);

Assignee: dpiX LLC (Palo Alto, CA)

New US Patent Application, Lyon & Lyon Docket No. 253/003