

WSTIAC

Volume 2, Number 3

July 2001

WEAPON SYSTEMS TECHNOLOGY INFORMATION ANALYSIS CENTER



Contents

Combat Hybrid Power System.....	1
Director's Corner.....	3
FYI.....	8
Smart Weapons Training Seminar.....	10
Calendar of Events.....	11

WSTIAC is a DoD Information Analysis Center Sponsored by the Defense Technical Information Center and Operated by IIT Research Institute



Combat Hybrid Power System CHPS

by Ghassan Khalil and Terence Burke
US Army TACOM

The CHPS Program started in 1995 as a partnership between DARPA and TACOM to investigate and demonstrate the feasibility of an integrated combat vehicle system. This system was designed for a 15-ton wheeled vehicle which would include an ETC gun, EM armor, would meet the mobility requirement of future combat vehicles and also be transportable in a C-130. Although the concept is designed for a notional 15-ton vehicle, all technologies developed under the CHPS are to be scalable from 4 to 40 tons vehicle weight.

The reasons behind this program reside mainly in the fact that future vehicles have to be smaller, lighter, more deployable, more agile, more lethal and more survivable than the current fleet of vehicles. Studies have shown that the state of the art technologies used in conventional vehicles are not adequate for meeting all these requirements. The amount of electric power will have to be increased from a few kilowatts to megawatt levels. Consequently energy storage to meet the electric power demand onboard the vehicle becomes critical and is beyond what standard auxiliary power units (APUs) can provide. Therefore, new enabling technologies had to be identified, developed and demonstrated in an integrated system, as they would function in a combat vehicle. Based on that, the CHPS program was introduced in two phases. Phase I consisted of identifying the best possible design to achieve the program goals and was carried out by three separate teams of contractors, government engineers and academia experts. The second phase consisted of three parts: assessing the state of development of the identified technologies in Phase I and pursuing the development of those technology candidates with the most promising potential; demonstrating the developed technologies in a System Integration Lab (SIL); and developing and validating virtual prototype models to evaluate future combat vehicles at different weight classes and for various mission scenarios.

CHPS Concept

CHPS is an integrated power management and distribution system that can deliver power to high pulse loads and continuous loads simultaneously according to a programmable control precedence.

(Continued on page 2)

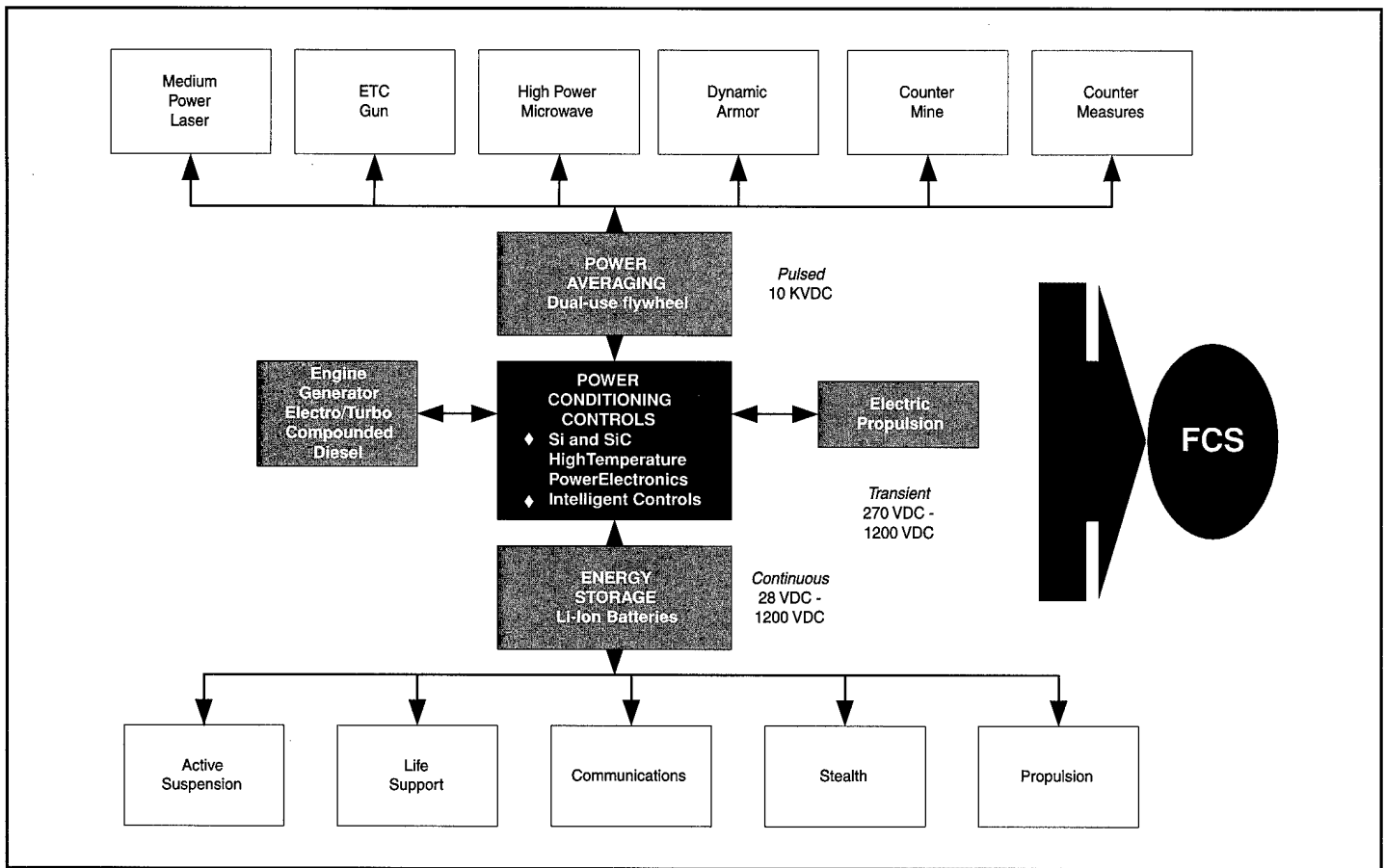

Figure 1: CHPS Concept

This concept is shown schematically in Figure 1.

The prime power is derived from two sources, the engine-generator and the energy storage system. The power split is programmed and balanced according to the duty cycle dictated by the mission scenario. For the CHPS program, a mission scenario was developed, based on user's input and on existing duty cycles, to establish a requirement definition for the notional 1.5-ton vehicle. This was particularly useful for continuous loads, such as propulsion. For pulse power, a combination of flywheel and capacitor Pulse Forming Network was initially considered which required a 300 kW flywheel development program. This was later removed from the program due to funding constraints.

Technology Development

Among the technologies identified in Phase I, Silicon Carbide (SiC), Lithium Ion batteries, high speed flywheel, high energy density capacitors, in-hub electric traction motors, advanced Silicon inverter with repackaged IGBT and electric turbo-compounding were believed to be the most important ones that could be developed and demonstrated by the year 2004. Other technologies such as fuel cells, matrix inverters, and switch reluctance motors were considered longer term and subject to evaluation pending further development.

The high-speed flywheel and the SiC were initially linked together in the program. The flywheel was to be developed by UT-CEM, and a SiC inverter controlling the operation of the flywheel was to be developed by Northrop Grumman. Extensive work was required for each. As mentioned earlier, the flywheel was removed from the CHPS program because of funding constraints. However, because of the potential of SiC as an enabling technology, the SiC devices originally intended for the 300 kW SiC inverter, were kept and used to develop a 150 kW SiC DC-DC converter consisting of three modules at 50 kW each.

Although the high speed flywheel for the ETC gun was cancelled, another load averaging flywheel with a 2kw-hr capacity was leased from Magnet Motor of Germany, and used in the SIL to evaluate its performance as a mechanical battery with fast energy discharging characteristics.

Silicon Carbide

Silicon carbide (SiC) is an emerging semiconductor material with properties that can greatly improve the performance of power devices. Silicon carbide, with crystal quality suitable for electronic devices, first became commercially available in large quantities from Cree Research, Inc. in 1989. Even in the

(Continued from page 2)

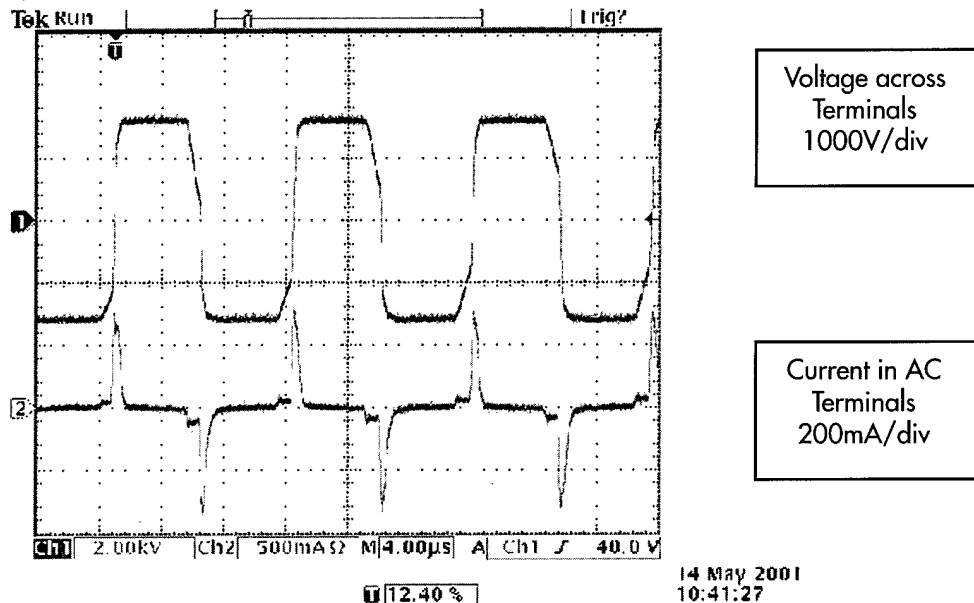

Figure 2: CHPS High Voltage SiC Rectifier operating at 3200V and 83 kHz, no load.

relatively early stages of material development, prototype silicon carbide power devices demonstrated an impressive potential by operating at much higher temperatures and power densities than silicon devices, and by efficiently controlling current at high voltages and high switching rates not possible with currently available silicon devices. Cree Research reports reliable operation of silicon carbide thyristors at over 900° F. Fast, efficient silicon carbide rectifiers have reduced inverter losses by >10% while operating at 100 kHz and 300 volts. Figure 2 shows the CHPS SiC rectifier operating at 83 kHz and 3200 V. The combination of these capabilities offers the possibility of performing electric motor control, power conversion and thermal management with systems that are, arguably, 70-80% smaller. This addresses the main challenge for future Army hybrid electric combat vehicles - how to fit high power systems for continuous and pulsed power on a mobile vehicle.

Advances in a number of areas are needed, to ultimately realize silicon carbide's full potential: SiC material growth, power device design, power converter design, development of capacitors and magnetics, packaging and thermal management. By targeting key developments in inverter design and packaging, the CHPS program aims to build a high power silicon carbide based converter using currently available silicon carbide materials and prototype devices. In the course of the program, Northrop Grumman demonstrated the highest powered all-silicon carbide motor drive at approximately 50 W. The challenging goal of the CHPS program is to demonstrate a 50,000 W dc-dc converter module. The program addresses all efforts needed to achieve high-temperature high-frequency operation using available silicon carbide gate-turn-off thyristor (GTO) devices. This difficult task is further compounded by the fact that available devices are only about 0.04" square.

A high voltage dc-dc converter was chosen to charge the pulse power energy store, a high voltage (10kV) capacitor bank. The improved low-loss high frequency switching capability and the high operating temperature of silicon carbide are expected to dramatically reduce the size of the power converter while maintaining or improving the capacitor charging rate and frequency. Volume reduction is due to reduced transformer and snubber capacitor size associated with high frequency operation, and to high power density device operation and packaging. The overall volume is expected to be reduced to approximately 10-20% of a comparable silicon-based converter. It is also expected to reduce size of the thermal management system by a factor of 5. High temperature capability facilitates more efficient heat transfer by increasing the temperature difference between heat sink and ambient, and also allows for higher power operations for short duration. For the first time, a compact air-cooled system may be feasible.

The converter will be supplied from the main dc voltage bus (nominally 500 VDC). Each 50 kW module will produce about 3300 VDC. Modules can be stacked to achieve the higher voltages and power levels required in a fielded system. Improved SiC device performance is expected to allow module operation at 100 kHz (and 50 kW). Each module is composed of three sections: 1) a 500V H-bridge inverter, 2) a high-frequency transformer, and 3) a high-speed high voltage (10kV) rectifier. The H-bridge will operate at junction temperatures up to 250° C.

In order to achieve 50 kW, Northrop Grumman developed low-inductance packaging capable of operating more than 80 of these devices in parallel. Devices are "sandwiched" between high thermal conductivity ceramic substrates. Because

(Continued on page 4)

(Continued from page 3)

of the high operating temperature, the thermal expansion of the sandwich materials must be closely matched to the silicon carbide. Reliable high temperature brazing, and reliable high-temperature insulation, capable of withstanding much higher electric fields and high frequency, are significant related advancements.

Silicon carbide has material properties that make it a power device designer's dream, but a manufacturer's nightmare. Compared to silicon, its thermal conductivity is 2-3 times higher, bandgap is about 3 times higher, and critical field is almost an order of magnitude higher. These properties allow designers to design devices that can operate at 600° C vs. 125° C, and have 100x the power density. It offers the near-term possibility to make devices that can operate at 3000V, 300 A/cm², 100kHz, 200° C, and to shift the thermal limitation from the device to the packaging. Although material quality has improved steadily, usable area is still limited by "killer" defects known as "micropipes" or "micropores." The presence of a single defect will significantly reduce device blocking voltage. These defects occur in high concentrations, on the order of 25 - 100 cm², but selected wafers may have as little as 5/cm². The distribution of micropipes is non-uniform, so selected areas of the highest quality wafers may have significant area (1 cm²) with no micropipes. Using this approach, Cree Research has reported large-area (cm²) devices. Otherwise, in order to achieve a suitable yield of high-performance devices, small devices must be used.

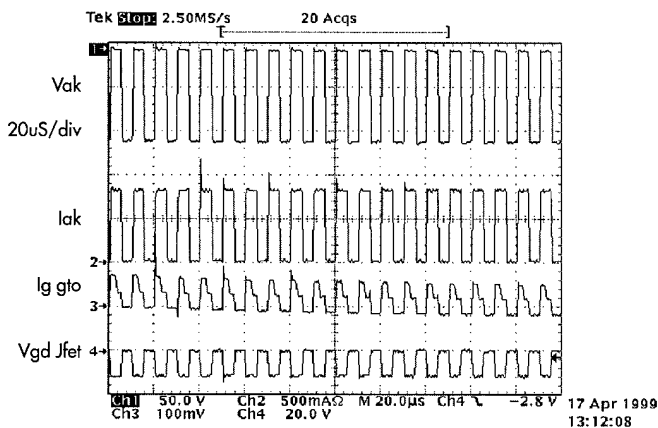

Figure 3: CHPS SiC GTO operating at 100 kHz, 100V and .75 A

As a result, current rating is limited to 2-5 A per device, and many devices must operate in parallel to make a high current module. At the time devices were fabricated for the CHPS program, a good yield could be obtained by using 1 mm x 1 mm device size. With recent improvements, 2 x 2 or even 3mm x 3mm devices are possible. This effective 4-9 time improvement in current rating will greatly simplify power module fabrication.

Today, GTO's and rectifiers are the most reliable silicon carbide devices demonstrated at high power and voltage. Ultimately, more efficient "majority carrier" silicon carbide device structures can be used at high powers. Silicon carbide FETs can be expected to have comparable performance to silicon IGBTs and GTOs, with improvements in operating frequency and efficiency. SiC GTOs have demonstrated both high temperature and high frequency operation at high voltage. Figure 3 shows operation of the CHPS SiC GTO at 100 kHz and 100V. The GTO has drawbacks with respect to control and conduction loss. In silicon, its diode-like conduction characteristic is superior, particularly at very high power. However, the wide-bandgap characteristic of silicon carbide makes the minimum possible forward voltage drop of the SiC GTO 2.7 volts rather than 0.7 volts, significantly higher than silicon. Northrop Grumman is the prime subcontractor, but device development was also performed by GE CRD, both under the DARPA MegaWatt Switch Program, and later by Cree Research, Inc., in part under a joint DARPA-ONR program.

Batteries

Lithium Ion Batteries: Several types of batteries were considered, from inexpensive lead acid to Lithium polymer, which is still in development. The Li-Ion battery was selected due to its potential as a pulse power source and its high energy density which can exceed that of a lead acid battery by a factor of three.

The power density of the Li-Ion battery can exceed that of the lead acid by about an order of magnitude. Figure 5 illustrates one interesting feature of these batteries. It demonstrates that the current passing capability increases with temperature as the internal resistance of the battery decreases.

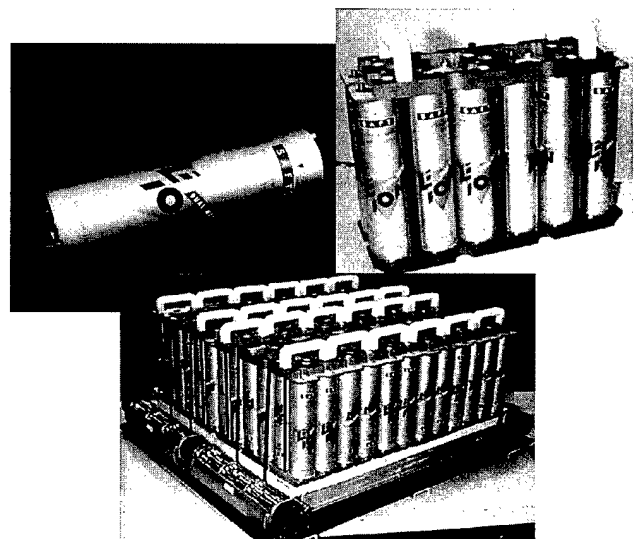

Figure 4: CHPS Li Ion Batteries

(Continued on page 5)

(Continued from page 4)

Nominal Voltage [V]	3.6
Capacity at C/2 rate [Ah]	30
Specific energy [Wh/kg]	105
Energy density [Wh/l]	235
Specific Power [W/kg]	1100 See Note 1
Power Density [W/l]	2140
Self Discharge	<1.5% per Month
Diameter [mm]	54
Case Height [mm]	208 max
Weight [g]	1050
Volume [dm ³]	0.5

NOTE 1: 50% SOC 18S Pulse Discharge & Instantaneous Pulse Regeneration
 NOTE 2: Energy density and power density are at the cell level, not at the module or pack.

Traction Motors

The electric motors used in the CHPS notional vehicles are advanced design AC induction motors as shown in Figure 6. These motors have been designed with improved internal cooling circuits to increase their torque capability, allowing the vehicle to develop a tractive effort to weight ratio of 1.3 ($t_e/w_t=1.3$) on a transient basis. The motors shown in figure 6 are used in tandem for tracked vehicles or individually mounted on the axle for wheeled vehicle applications. Currently, each axle has one drive motor making the CHPS notional vehicle a 3x6. Ideally, motors in a hybrid wheeled vehicle should be installed in each wheel to capitalize on the flexibility of component arrangement and their packaging density. Furthermore, the in-hub motors provide pivot and skid steer capability and also add redundancy to the drive system. In-hub motors must be of pancake type configuration as shown in Figure 7. They must be light weight and have high torque density so as not to add too much weight to the unsprung mass and compromise the mobility of the vehicle. The motor shown in Figure 7 is an axial gap permanent magnet motor that will be evaluated in the CHPS program for in-hub application.

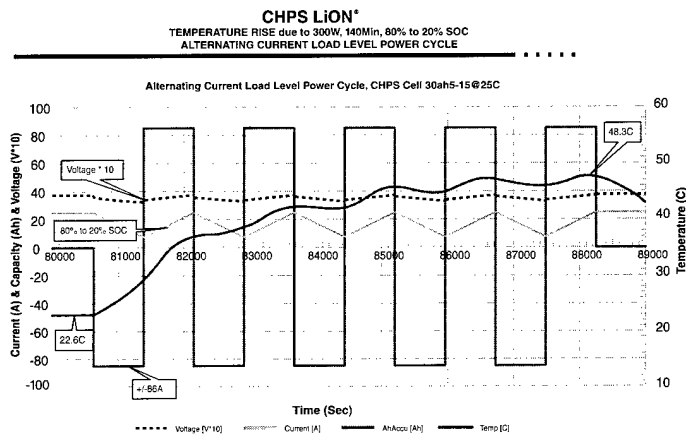

Figure 5: Current passing capability

Pulse Forming Network (PFN)

The high auxiliary electric power demand required by electric weapons (ETC gun and Directed Energy Weapons: HEL and Microwaves) must have a PFN to deliver the pulse power to the load. PFNs must be sufficiently compact to be integrated into a combat vehicle. This depends on the state of development of high voltage and high current capacitors and the thermal management. In the interim, CHPS used existing PFN from the Defense Special Weapons Agency (now the Defense Threat Reduction Agency) that had capacitors with energy densities on the order of 0.3 j/cc. New development of film capacitors and upgraded PFN is in progress. These will be evaluated in CHPS to investigate their potential for pulse power applications. The new capacitors will have energy density on the order of 2.5 j/cc. In the long term, film capacitor developers believe they can reach energy densities higher than 10 joules/cc.

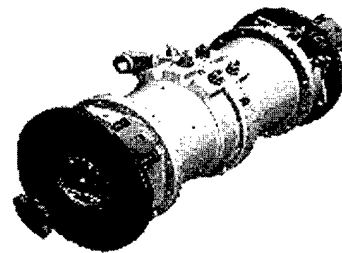

Figure 6: AC induction motor.

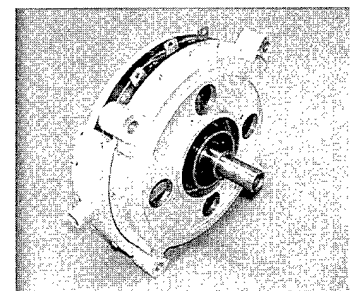

Figure 7: In-hub axial gap permanent magnet motor.

Electric Turbo Compounded Prime Mover

Turbocompounding is not a novel idea. Earlier efforts demonstrated some payoffs, but only at certain portions of the speed and load range, particularly at the higher end. For a military vehicle (hybrid in particular) the turbocompounding benefit is potentially significant. The heat energy, which is normally dissipated, can be used to drive a generator and produce electrical energy, thus increasing the efficiency of the prime power by 10 to 12%. A study of this concept was

(Continued on page 6)

(Continued from page 5)

conducted under the CHPS (Figure 8) The thermodynamic analysis proved, if nothing else, that this is a concept worth pursuing in the lab. However, just as in the case of the flywheel, this portion of the program had to be cancelled because of insufficient funding. We will use the previous analysis as a baseline to explore and validate the efficiency increase from exhaust heat energy.

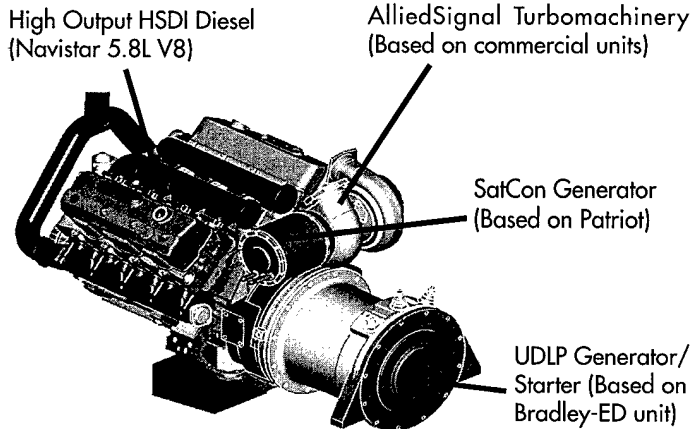

Figure 8: Electric Turbocompounding

Advanced High Temperature Si Inverter

The Silicon inverter is an intermediate solution to the hybrid electric drive thermal management problem while SiC power semiconductors remain in the development stage. The size of the cooling system in commercially available semiconductor devices, such as IGBTs, is not acceptable for combat vehicle applications. The main reason is the junction operating temperatures of the switching devices (125° C) and the coolant inlet temperature (65° C) at the base plate of the IGBT. The

temperature difference between the base plate and the junction is due to the several electrical insulating layers between the base and the junction. The advanced inverter developed under the CHPS program uses IGBTs that have been repackaged without some of the insulation which contributes to the temperature difference (DT). This inverter allows the coolant temperature to rise to 90° C thus reducing the cooling system size by approximately 50%.

The System Integration Lab (SIL)

The SIL shown in Figure 9 is a lab facility where all components and subsystems that make up the combat hybrid power system can be integrated and validated. Full power and energy storage with real loads and/or load simulators are assembled, as they would function in a combat vehicle. These subsystems include the ETC gun and EM armor load emulator, the PFN, the Li-Ion battery bank, engine/generator, flywheel, traction motors, and controllers operating within a power management and distribution architecture, with the associated thermal management, grounding, shielding and all ancillaries.

The SIL is designed to be reconfigurable to evaluate different concepts and different component technologies. It is located at UDLF's facilities in San Jose. It is open and available for government contractors to test their hardware, particularly for the Future Combat Systems (FCS) contracts. The SIL was completed in 1999, and demonstrated with the components and systems described above. The feasibility of the CHPS concept shown in Figure 1 was also demonstrated. Simultaneous power delivery for pulse and continuous loads was also demonstrated. This represents shooting an ETC gun mounted on a combat vehicle turret while moving the vehicle at high speed, i.e. fire on the move maneuvers.

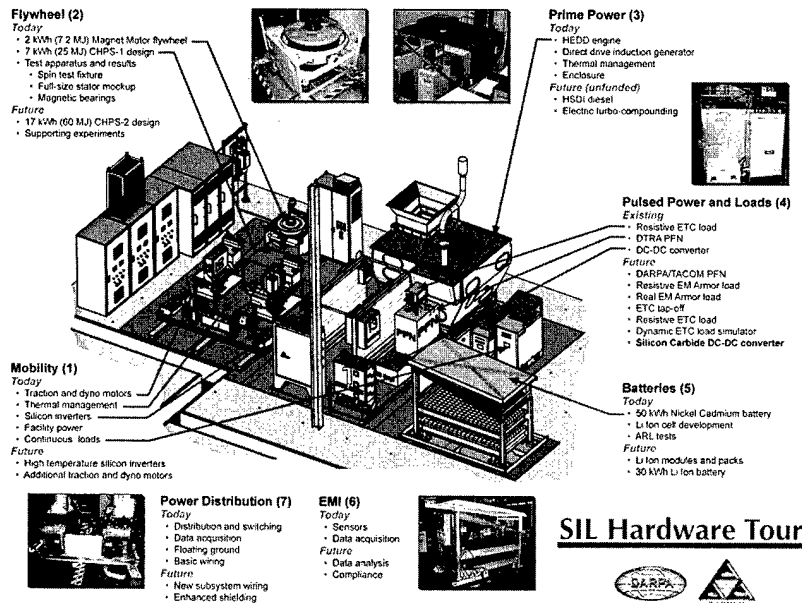
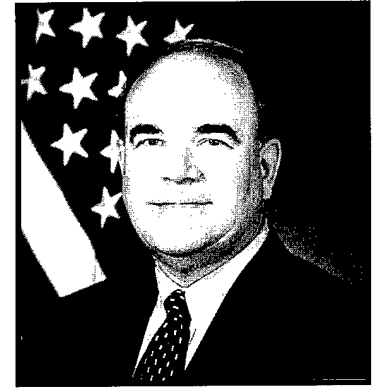

Figure 9: The System Integration Lab (SIL)

Director/Chief Scientist's Corner

A View from Washington

by Dr. Wes Kitchens



The Office of the Deputy Under Secretary of Defense (Science and Technology) has increased its focus on electric armament and protection technologies because of a growing realization that electric technologies will play a critical role in many future weapons systems and platforms, helping DoD achieve warfighter requirements within acceptable cost and risk parameters. The WSTIAC worked closely with the DUSD(S&T) Weapons Systems Directorate to plan and conduct an Electric Armament and Protection Technology Workshop that was held 26-29 March 2001 at the Institute for Defense Analyses in Alexandria, VA. This workshop was co-organized with the relevant Reliance Panels: Weapons, Ground and Sea Vehicles and Air Platforms.

This workshop assessed the state-of-the-art of current electric armament/protection technology programs and identified critical future needs. The goals of the workshop were to:

- ◆ Identify technology gaps;
- ◆ Identify integration issues;
- ◆ Explore technology opportunities;
- ◆ Identify cross-cutting themes for possible joint/collaborative programs; and
- ◆ Enhance Reliance.

Eighty-seven electric armament and protection technology experts, representing the Service Labs (Army, Navy and Air Force), DoD Agencies, warfighting and requirements organizations, DIA, DOE, industry and academia participated in this workshop.

The workshop consisted of 1½ days of plenary sessions, with presentations that covered the threat, DoD requirements for electric armament and protection technology, current ground, sea and air electric armament and protection technology programs (including funding levels and future plans) and related DOE Laboratory programs. The Workshop attendees were each assigned to one of three technical panels: Electric Armament and Lethality Technology, Electric Protection Technology and Enabling Technology. These three technical panels met simultaneously for one day to deliberate and address the following questions with respect to their assigned technology area:

- ◆ Do we have the right S&T goals;
- ◆ What are the technology opportunities;
- ◆ What, if any, are the impediments and speed bumps;
- ◆ Is our emphasis correct;
- ◆ What gaps exist in the current S&T programs;
- ◆ What is the technology readiness level;
- ◆ When can the technology be fielded;
- ◆ Is the current funding profile adequate;
- ◆ What program/funding changes do you recommend; and
- ◆ What are the opportunities for joint/collaborative programs.

Panel outbriefings on the last half day gave each technical panel chair an opportunity to present their panel's response to the above questions.

The findings and recommendations from the workshop included:

- ◆ Electric technology offers considerable potential to reduce the size & weight of ground, sea and air platforms and significantly increase warfighting capabilities;
- ◆ There are opportunities to enhance current electric-armament and protection technology programs and accelerate the application of this technology to ground, sea and air platforms;
- ◆ Common thread is dependence on enabling/component technology maturity; but, there is a lack of critical mass, both individually & collectively; and
- ◆ Intellectual/industrial base in enabling technologies is very fragile.

The current issue of the *WSTIAC Newsletter* features an article by Messrs. Gus Khalil and Terry Burke, Army Tank-Automotive and Armaments Command, that discusses Army and DARPA initiatives to develop a test bed for evaluating electric technologies for future ground combat vehicles.

We welcome your feedback about the *WSTIAC Newsletter* and solicit your suggestions for future topics you would like to see included. You can reach me by Email at wkitchens@itri.org or by phone at (703) 933-3317. ◆

FYI

Free Electron Lasers

FREE ELECTRON LASERS FOR WARSHIPS

Naval Postgraduate School Department of Physics
Distinguished Professor W. B. Colson

The Navy needs an effective and surgical defensive weapon against short-range missiles. Recently, it has become clear that we may need to defend ships against small boats without resorting to exploding our warheads near civilians.

Naval Postgraduate School Research Volume 11, Number 2 June 2001
(*NPS Research Newsletter* is published tri-annually by the Office of the Associate Provost and Dean of Research.)

<http://web.nps.navy.mil/~code09/newsletters/Jun01ResNews.pdf>

FREE ELECTRON LASER DEVELOPMENT FOR DIRECTED ENERGY

CDR Roger D. McGinnis, United States Navy
Doctor of Philosophy in Physics – December 2000

This dissertation investigates power requirements for a Free Electron Laser (FEL) to burn through various missile radome materials. It also includes computer simulation results for several FEL system configurations designed to achieve maximum power while maintaining strict energy spread constraints. The method used to determine power requirements to burn through materials was to use the Thomas Jefferson National Accelerator Facility Free Electron Laser to conduct material damage experiments. As the laser was improved and increased in power, the laser spot sizes on the target materials were increased while maintaining a constant irradiance. The key results from these experiments included determining minimal spot sizes that can be used for future experiments, and validations that an irradiance level of 10 kW/CM² can burn through most missile radome materials in a few seconds. The computer simulations involved changing various parameters of an FEL such as electron energy levels, pulse lengths, magnetic field strengths, desynchronism, as well as several other parameters, to determine the best possible configuration to achieve the desired power levels and energy spread requirements for development of a megawatt size FEL. The results indicated that for the proposed designs, both the required power and the required energy spread limit can be met. Available from DTIC as ADA387898.

(Continued on page 10)

Planning a Conference or Seminar?

WSTIAC can assist with technical support:

- ◆ Call for papers
- ◆ Announcements
- ◆ Local arrangements
- ◆ Author kits/paper selection
- ◆ Registration
- ◆ Security, meals, transport
- ◆ Exhibits, receptions
- ◆ Proceedings

The WSTIAC Newsletter is the current awareness publication of the Weapon Systems Technology Information Analysis Center (WSTIAC). WSTIAC, a Department of Defense (DoD) Information Analysis Center (IAC), is administratively managed by the Defense Information Systems Agency (DISA), Defense Technical Information Center (DTIC) under the DoD IAC Program. The Contracting Officer's Technical Representative (COTR) for WSTIAC is Mr. H. Jack Taylor, ODUSD (S&T), Defense Pentagon, Washington, D.C. 20301-3080, (703) 588-7405. IIT Research Institute operates WSTIAC, which services Government, industry, and academia as a Center of Excellence in Weapon Systems Technology.

WSTIAC Director: Dr. Wes Kitchens
703.933.3317,
Email: wkitchens@iitri.org

Database Inquiries: Vakare Valaitis
703.933.3362
Email: vvalaitis@iitri.org

Internet: <http://iac.dtic.mil/wstiac/>

All data and information herein reported are believed to be reliable; however, no warrant, expressed or implied, is to be construed as to the accuracy or the completeness of the information presented. The view, opinion, and findings contained in this publication are those of the author(s) and should not be construed as an official Agency position, policy, or decision, unless so designated by other official documentation.

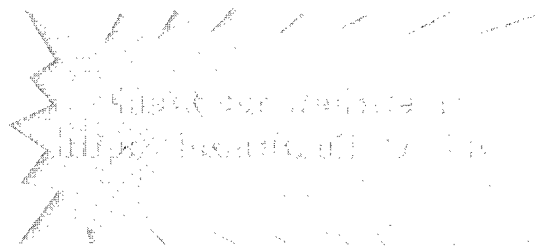

Smart Weapons Training Seminar Offered at Your Location

WSTIAC can conduct its 2½ day Smart Weapons Training Seminar at your location during 2001 to reduce your travel time and cost. This seminar has been presented to hundreds of students over the past decade. This is a very cost effective way to provide smart weapons training to up to 35 people at your site.

Seminar Scope:

The Weapon Systems Technology Information Analysis Center (WSTIAC) developed this 2½ day Smart Weapons Training Seminar to provide a comprehensive understanding of smart weapons and related technologies. This seminar is aimed at providing general knowledge about smart weapons technology and a source of current information on selected U.S. and foreign smart weapons, to include system description, concept of employment, performance characteristics, effectiveness and program status.

Seminar Objectives:

The seminar's objective is to inform materiel and combat developers, systems analysts, scientists, engineers, managers and business developers about smart weapons to include: State of the art of representative U.S. and foreign smart weapon systems; Employment concepts; Smart weapons related systems, subsystems, and technologies; and Technology trends.

Seminar Sponsors:

- ◆ DUSD(S&T) Weapons
- ◆ Defense Technical Information Center(DTIC)
- ◆ Joint Technical Coordinating Group Munitions
- ◆ Effectiveness (Smart Munitions Working Group)

About the Seminar:

This seminar was originally developed for the U.S. Army Command and General Staff College in Fort Leavenworth, Kansas. It has proven to be enormously popular with attendees from both government and industry. The seminar is updated annually to include current information about the latest technology and capability upgrades being made to representative US and foreign smart weapon systems. Instructors include: Dr. Wes Kitchens, WSTIAC Director and former DDR&E Director for Weapons Technologies; Mr. Mark Scott and Mr. Hunter Chockley, IITRI Science Advisors; and Mr. Mike Holthus, foreign weapons expert at the National Ground Intelligence Center.

Security Classification:

The security classification of this seminar is SECRET (U.S. Citizens Only).

Fee:

The fee for conducting this Smart Weapons Training Seminar at your location is \$25K for up to 35 students, payable by MIPR, purchase order or government credit card. ◆

**Please call Mrs. Shirley Hardy
at (256) 382-4756 or
email shardy@iitri.org
for more information and a brochure
with seminar details.**

Virtual Prototype

The virtual prototype model was developed by SAIC and UT-CEM to evaluate new concepts in components and architectures for future combat vehicles. It provides information on the feasibility of various mission scenarios in a virtual environment. This tool is intended to guide the development of critical technologies and their integration into a notional vehicle, thus creating a hardware/driver in the loop. The models are to be validated with the SIL hardware test data. The virtual prototype models take into consideration all design and integration elements of the vehicle, including grounding, EMI shielding and thermal management. The 15-ton virtual prototype system is shown in figure 10.

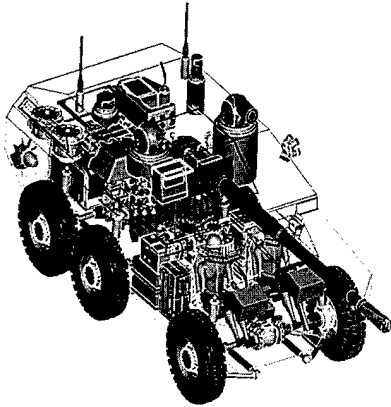

Figure 10: Virtual Prototype

Summary

The CHPS technology development program is very unique. It is the first attempt to put a power integration system that includes both pulse and continuous power under one architecture and one power management system. The SIL facility provides the means to validate emerging technologies and to verify their viability in a vehicle system environment. The results obtained from the CHPS provides adequate support to other Army programs, and provides decision makers with the proper technical information necessary for the right technology choices. ♦

About the Authors:

Ghassan Khalil holds a M.Sc in Mechanical engineering from Wayne State University. He joined TACOM in 1985 working in the propulsion area, mainly drivetrain. He has been the team leader of the electric drive team since 1989. Previously he worked for Ford Motor Company in the area of powertrain test and evaluation. He has worked with six NATO nations on the development and demonstration of hybrid electric drives. He is chairman of the International committee on All Electric Combat Vehicles (AECV) and has been a member of the Society of Automotive Engineers for over twenty years.

Terence Burke received the Ph.D. in Electrical Engineering at Rutgers Univ. in 1993. He joined the U.S. Army TACOM in 1997, and has worked on the development of SiC power devices and packaging, and systems application of SiC power devices. He is the CHPS SiC IPT lead. He previously worked in Pulsed Power at the Army Research Lab. (88-97), in the areas of laser-activated switching devices, high-Tc superconductors, and SiC thyristors. He holds patents for AlGaAs/GaAs opto-thyristors, laser-activated semiconductor switches, and nano-particle generation. ♦

FYI (Continued from page 8)

Spectrum Management

Investigation of the Feasibility of Accommodating the International Mobile Telecommunications (IMT) 2000 Within the 1755-1850 MHz Band 9 February 2001

The 1755-1850 MHz band is used for critical national defense systems such as telemetry, tracking, and commanding of satellite systems (i.e., GPS, Milstar, and Defense Support Program (DSP), among others); precision guided munitions; tactical radio relay communication systems; air combat training systems; targeting; intelligence; and the real-time delivery of voice, video, and data information to warfighters and their commanders. The band may be auctioned off in the United States to the next generation of public cell phones – also referred to as Third Generation, or International Mobile Telecommunications 2000.

<http://www.ntia.doc.gov/ntiahome/threeg/33001/dodassessment.pdf>

Targeting: Lethal and Nonlethal

The current issue of *Field Artillery Magazine* features a number of interesting articles on the topic of targeting. *Field Artillery* is a bimonthly magazine published by the US Army Field Artillery, Fort Sill, Oklahoma.

<http://sill-www.army.mil/FAMAG/>. ♦

WSTIAC Wants Your Contributions

We hope you find this issue of the WSTIAC Newsletter useful and interesting.

You can help us to better serve you by your contributions, such as:

- ♦ Your comments on what you liked and disliked about the Newsletter
- ♦ Your suggestions for WSTIAC data products and services
- ♦ Technical articles, opinion pieces, tutorials, news releases or letters to the Editor for publication in the Newsletter

To contact WSTIAC, use any of the ways listed on the back cover, or use the feedback form on the WSTIAC webpage.

We welcome your contributions. ♦

Calendar of Events

Upcoming Conferences and Courses

7-9 August 2001

The Millennium Attrition Symposium
Michigan Technological University

For additional information:

Contact Dr. Bruce Fowler

Email: bruce.fowler@rdec.redstone.army.mil

13-16 August 2001

Small Arms Conference
Little Rock, AR

For additional information:

Email: djenks@ndia.org

[http://register.ndia.org/interview/
register.ndia?~Brochure~1610](http://register.ndia.org/interview/register.ndia?~Brochure~1610)

14-16 August 2001

4th Annual Testing and Training Symposium
Orlando, FL

For additional information:

Email: pedmonson@ndia.org

[http://register.ndia.org/interview/
register.ndia?~Brochure~1070](http://register.ndia.org/interview/register.ndia?~Brochure~1070)

21-23 August 2001

Smart Weapons Training Seminar
Huntsville, AL

For additional information:

Call Shirley Hardy at 256.382.4756

Email: shardy@iitri.org

<http://wstiac.iitri.org/NewsAndEvents/swcann.html>

29-30 August 2001

3rd Air and Space Protection Conference
U.S. Air Force Laboratory
Kirtland AFB, NM

For additional information:

<http://www.aochq.org/>

10-13 September 2001

Joint Undersea Warfare Technology Conference
Groton, CT

For additional information:

Email: kwilliams@ndia.org

[http://register.ndia.org/interview/
register.ndia?~Brochure~124](http://register.ndia.org/interview/register.ndia?~Brochure~124)

11-14 September 2001

ION GPS-2001 Meeting
Salt Palace Convention Center
Salt Lake City, Utah

For additional information:

<http://www.ion.org/meetings/gps2001cfa.html>

24-26 September 2001

Combat Vehicles
Ft. Knox, KY

For additional information:

Email: hjmason@ndia.org

[http://register.ndia.org/interview/
register.ndia?~Brochure~162](http://register.ndia.org/interview/register.ndia?~Brochure~162)

8-11 October 2001

2001 Insensitive Munitions and Energetic Materials
Cité Mondiale
Bordeaux, France

For additional information:

Email: imemts@clubmurat.com

[http://register.ndia.org/interview/
register.ndia?~Brochure~255](http://register.ndia.org/interview/register.ndia?~Brochure~255)

29 October - 2 November 2001

6th Annual Expeditionary Warfare Conference (EWC)
Bay Point Marriott Resort and Conference Center
Panama City, FL

For additional information:

Email: adekleine@ndia.org

[http://register.ndia.org/interview/
register.ndia?~Brochure~270](http://register.ndia.org/interview/register.ndia?~Brochure~270)

26-29 November 2001

Interservice/Industry Training, Simulation
and Education Conference I/ITSEC
Orange County Convention Center
Orlando, FL

For additional information:

Email: bmcdaniel@ndia.org

[http://register.ndia.org/interview/
register.ndia?~Brochure~225](http://register.ndia.org/interview/register.ndia?~Brochure~225)



Information Request

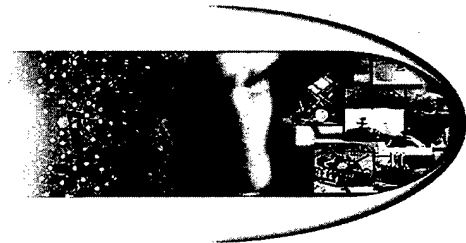

Please return this form to...
IIT Research Institute/WSTIAC
ATTN: Publication Department
215 Wynn Drive, Suite 101
Huntsville, AL 35805

or fax...
256.382.4701

- Checkboxes for adding name to newsletter, sending technical area task information, general information, correcting address, and sending subscriber information/publications list.

Name:
Organization:
Address: Telephone:
Fax:
E-mail:

Please also add my name to the following mailing lists:

- Checkboxes for MTIAC (Manufacturing Technology Quality), RAC (Reliability Maintainability and Processes), AMPTIAC (Advanced Materials and Testing), MSIAC (Modeling and Simulation), and IATAC (Information Assurance).



215 Wynn Drive, Suite 101
Huntsville, AL 35805

1901 N. Beauregard Street, Suite 400
Alexandria, VA 22311

Nonprofit Organization
U.S. Postage Paid
Huntsville, AL
Permit No. 4

Inside this issue...

CHPS
Director's Corner
FYI
Smart Weapons Training Seminar
Calendar of Events

4*1*****5-DIGIT 22060
PAT MAWBY
DEFENSE TECHNICAL INFO CENTER
OCP
8725 JOHN J KINGMAN RD STE 944
FORT BELVOIR VA 22060-6218

