

TRADOC BULLETIN NO 12
31 AUGUST 1979

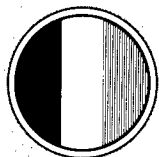
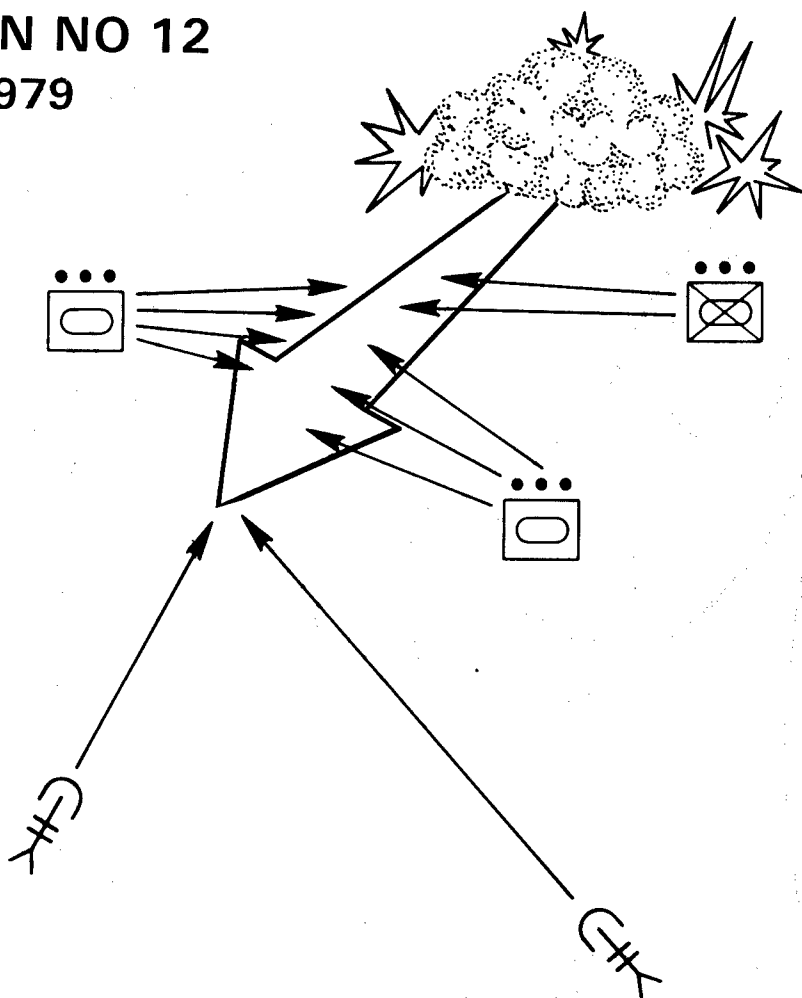

BATTLE REPORT

COMBAT VEHICLE ENGAGEMENTS

20010803 040

REPORT DOCUMENTATION PAGE

Form Approved
OMB No. 0704-0188

Public reporting burden for this collection of information is estimated to average 1 hour per response, including the time for reviewing instructions, searching existing data sources, gathering and maintaining the data needed, and completing and reviewing the collection of information. Send comments regarding this burden estimate or any other aspect of this collection of information, including suggestions for reducing this burden, to Washington Headquarters Services, Directorate for Information Operations and Reports, 1215 Jefferson Davis Highway, Suite 1204, Arlington, VA 22202-4302, and to the Office of Management and Budget, Paperwork Reduction Project (0704-0188), Washington, DC 20503.

1. AGENCY USE ONLY <i>(Leave blank)</i>	2. REPORT DATE 31 AUGUST 1979	3. REPORT TYPE AND DATES COVERED FINAL	
4. TITLE AND SUBTITLE TRADOC BULLETIN 12. BATTLE REPORT: COMBAT VEHICLE ENGAGEMENTS		5. FUNDING NUMBERS	
6. AUTHOR(S)		8. PERFORMING ORGANIZATION REPORT NUMBER	
7. PERFORMING ORGANIZATION NAME(S) AND ADDRESS(ES) HQ U.S. ARMY TRAINING AND DOCTRINE COMMAND ATTN: ATDOC-DDD FORT MONROE VIRGINIA 23651		10. SPONSORING / MONITORING AGENCY REPORT NUMBER	
9. SPONSORING / MONITORING AGENCY NAME(S) AND ADDRESS(ES)		10. SPONSORING / MONITORING AGENCY REPORT NUMBER	
11. SUPPLEMENTARY NOTES See TRADOC Bulletin 11 dated 2 March 1979			
12a. DISTRIBUTION / AVAILABILITY STATEMENT APPROVED FOR PUBLIC RELEASE; DISTRIBUTION IS UNLIMITED.		12b. DISTRIBUTION CODE	
13. ABSTRACT <i>(Maximum 200 words)</i> Recent technological advances have led to armor developments which substantially improve armored vehicle protection against both kinetic and chemical energy projectiles. Such armor is normally found on the front of modern tanks. So engage enemy tanks from flanks and rear. Locate battle positions along the flanks of enemy avenues of approach to allow flank and rear shots. Flank positions also place the enemy at a disadvantage because he must divide his attention in three directions--to the front and sides. Since engagement ranges are usually shorter from flank positions, there is a better chance of hitting the target. Also, more enemy targets will normally be in range. Discussion includes the tube-launched, optically tracked, wire-guided antitank missile (TOW); Dragons; Tanks; Mines and obstacles.			
14. SUBJECT TERMS		15. NUMBER OF PAGES 13	
17. SECURITY CLASSIFICATION OF REPORT UNCLASSIFIED		16. PRICE CODE	
18. SECURITY CLASSIFICATION OF THIS PAGE UNCLASSIFIED	19. SECURITY CLASSIFICATION OF ABSTRACT UNCLASSIFIED	20. LIMITATION OF ABSTRACT UNLIMITED	

UNITED STATES ARMY
TRAINING AND DOCTRINE COMMAND

BULLETIN NO 12

**BATTLE REPORT:
COMBAT VEHICLE ENGAGEMENTS**

Battle reports are used to disseminate lessons learned about how to fight on the modern battlefield. Data derived from observations, simulations, tests, and/or other evaluations are in the form of TRADOC bulletins entitled "**Battle Reports.**" These reports convey important developments of immediate interest to TRADOC agencies and to field commanders. They provide interim guidance until their content can be integrated into appropriate How-To-Fight, How-To-Support, or other doctrinal publications.

TRADOC centers, schools, agencies, and field commanders are encouraged to submit material for inclusion in future battle reports to HQ TRADOC, ATTN: ATDOC-DDD, Fort Monroe, VA 23651.

Contents

	Page
INTRODUCTION	2
TOWs	2
DRAGONS	5
TANKS	6
MINES AND OBSTACLES	9

Introduction

Recent technological advances have led to armor developments which substantially improve armored vehicle protection against both kinetic and chemical energy projectiles. Such armor is normally found on the front of modern tanks. So engage enemy tanks from flanks and rear.

Locate battle positions along the flanks of enemy avenues of approach to allow flank and rear shots. Flank positions also place the enemy at a disadvantage because he must divide his attention in three directions—to the front and sides.

Since engagement ranges are usually shorter from flank positions, there is a better chance of hitting the target. Also, more enemy targets will normally be in range.

TOWs

(Tube-launched, optically tracked, wire-guided antitank missile)

Position TOWs to kill enemy armored vehicles from the flanks. Avoid shooting TOWs at the front of enemy tanks. Remember, the gun on an attacking tank is usually pointed in the direction the tank is moving—to the front.

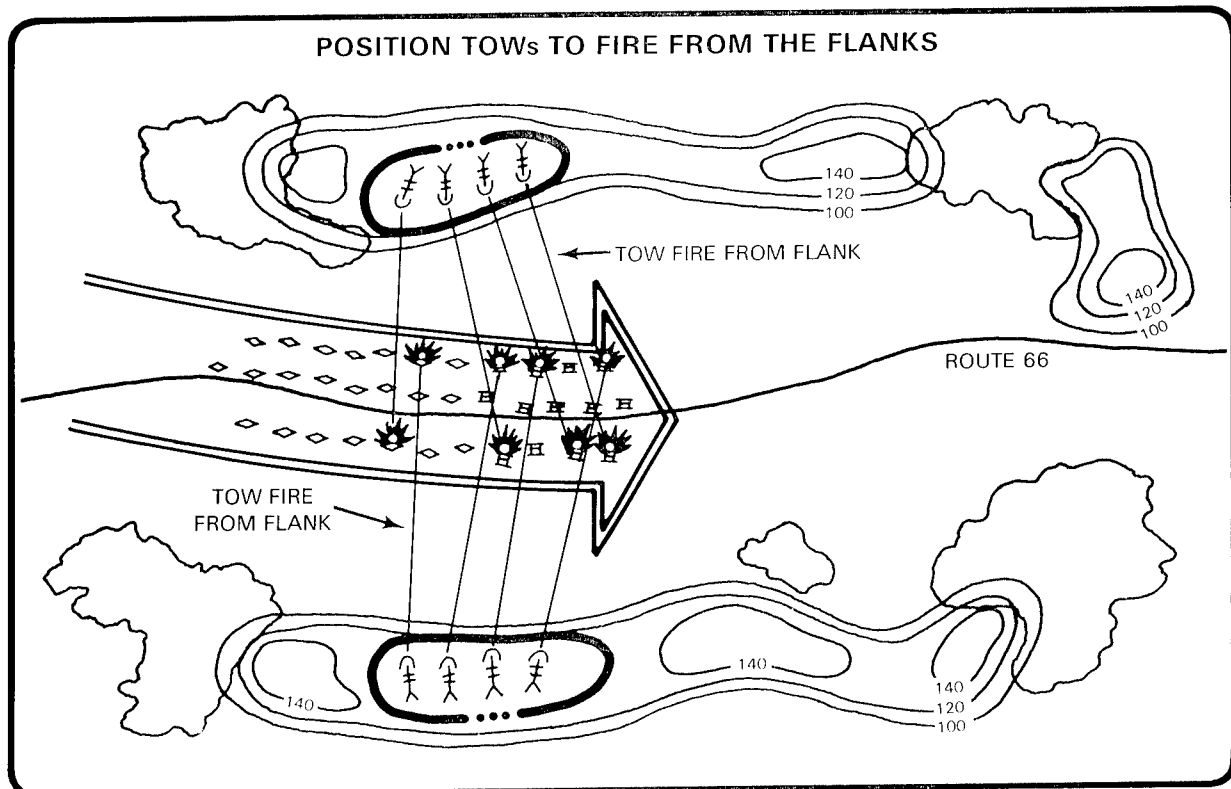

If you shoot from the flanks, the enemy tank will have trouble seeing you.
If the enemy can't see you, he can't shoot you so hit him in his blind area.

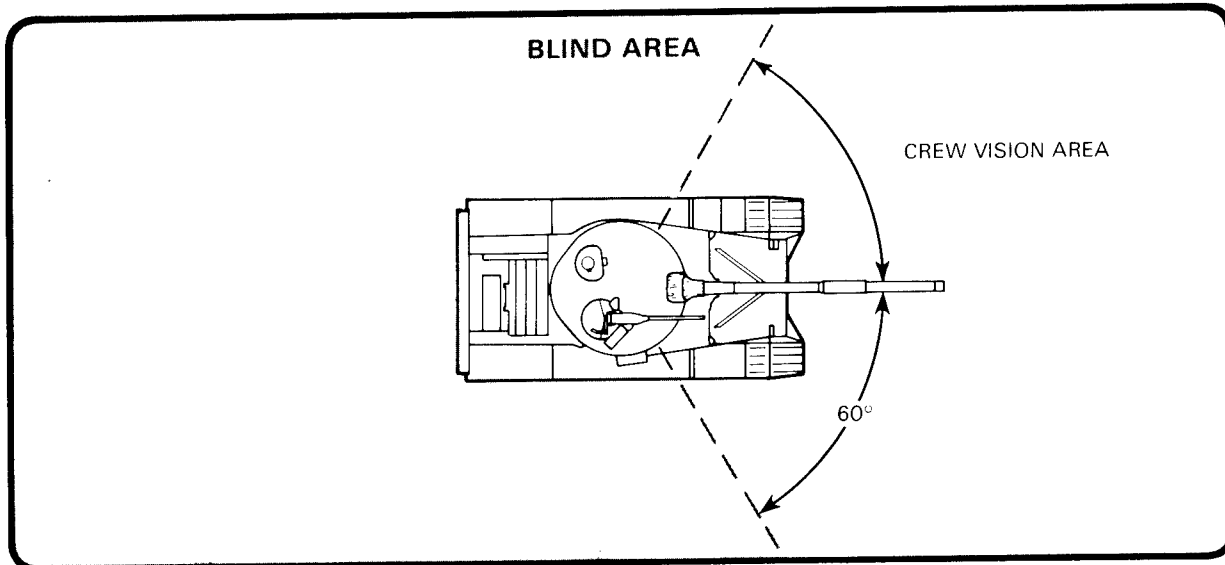

Use hide positions for TOWs when not firing. *This means you must use observers to find targets and call TOW vehicles forward to firing positions.*

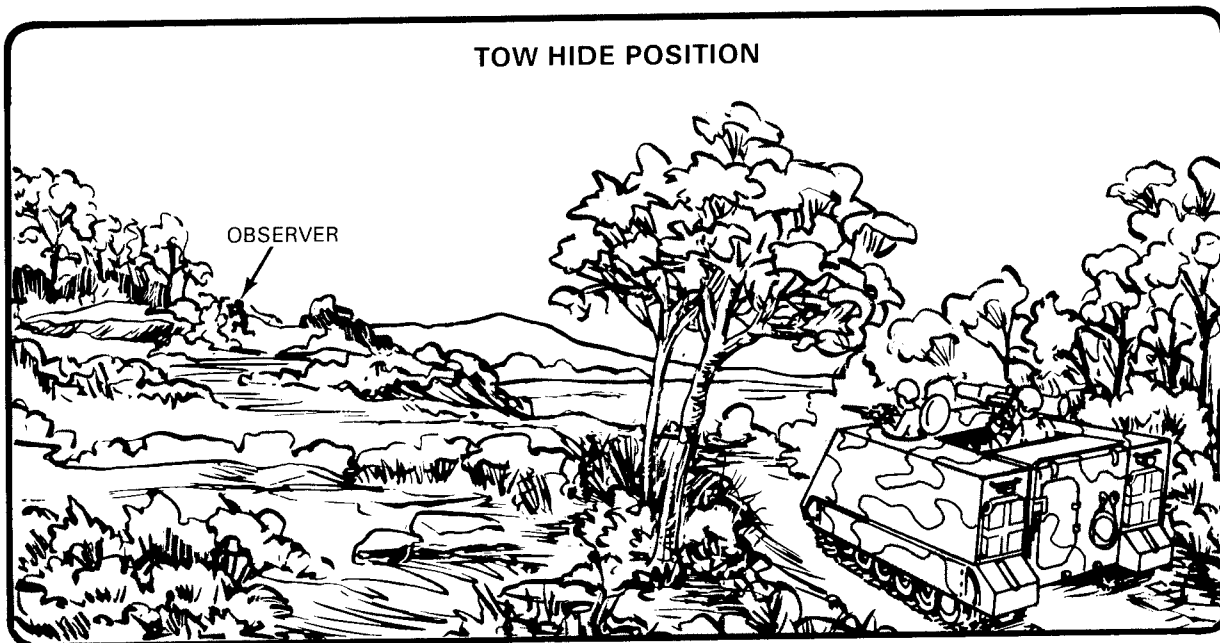

Prepare TOW firing positions so that TOW vehicles can move into them rapidly. *Make sure these positions have cover, concealment, and covered routes of withdrawal.*

Select alternate positions so they can be used if primary positions are smoked.

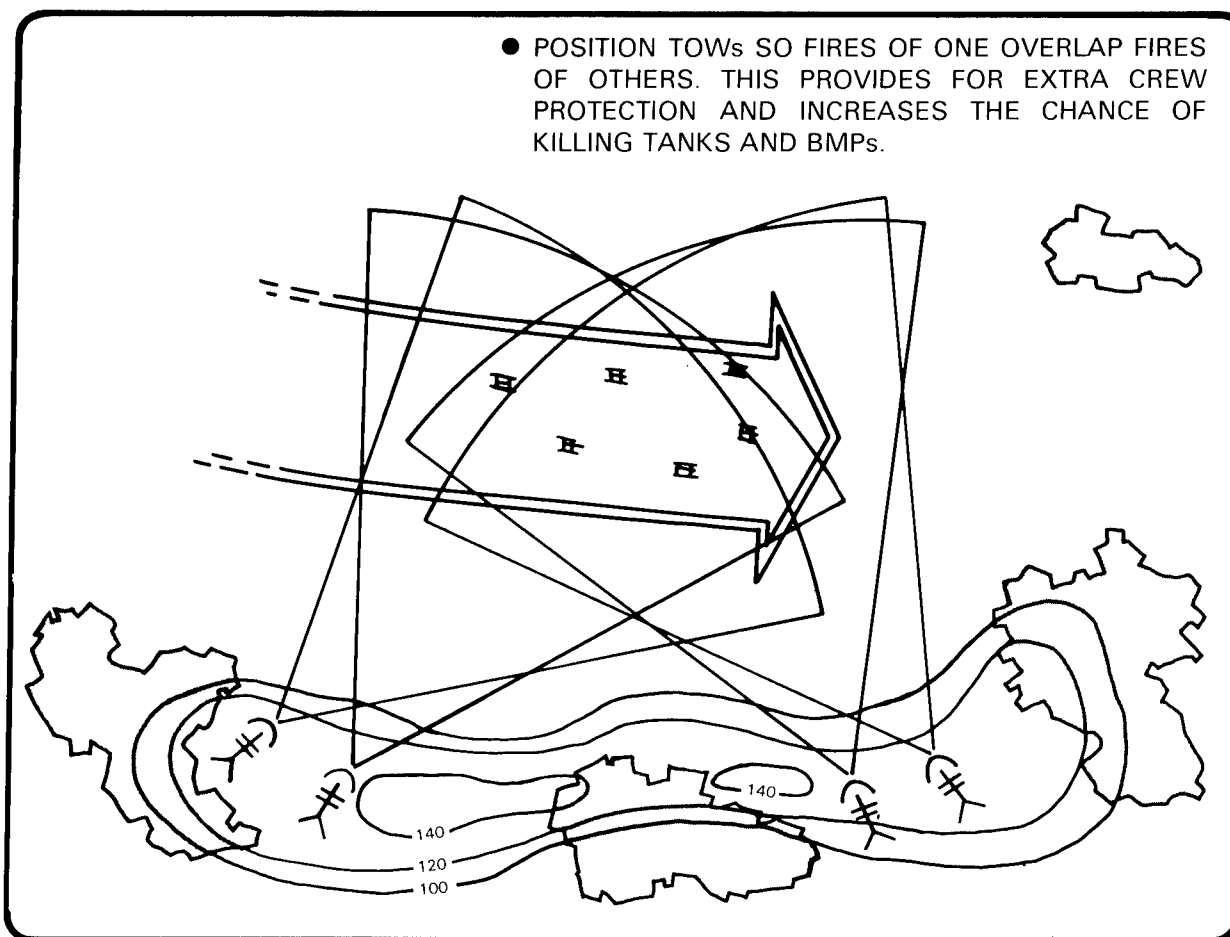
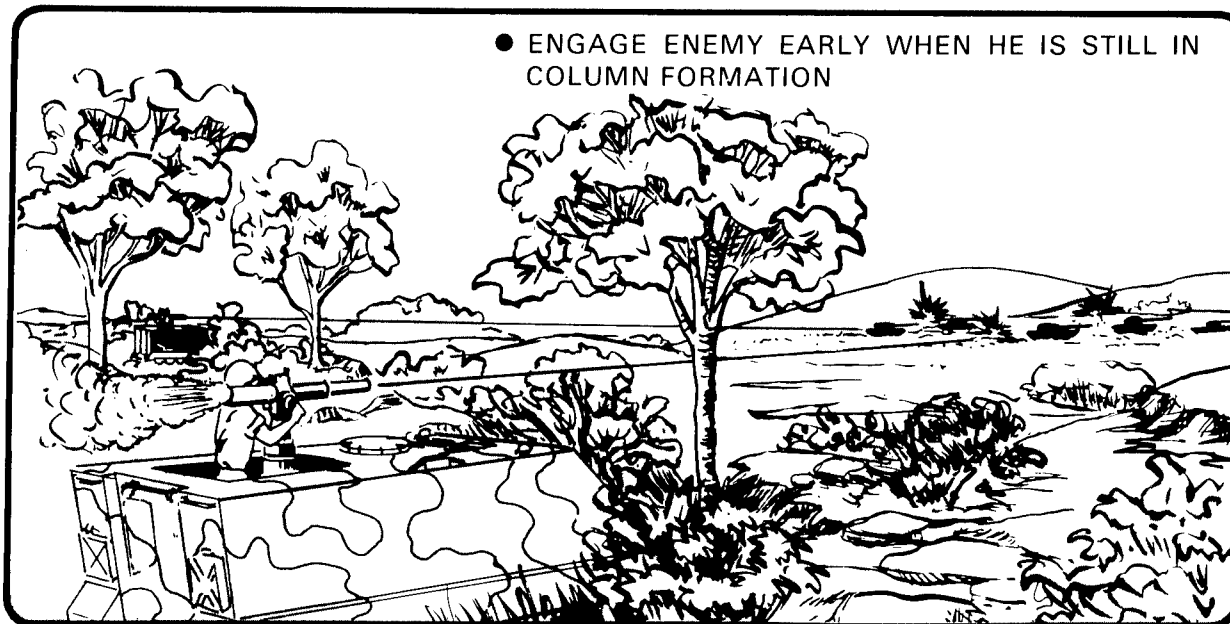

Dragons

Put Dragons in areas that have good cover and concealment. *Since Dragons are ground mounted, crew protection depends on a well-prepared position.*

Position Dragons to kill enemy tanks from flanks and rear. First, kill tanks and BMPs that present the greatest threat, then the others.

Position Dragons so that fires of one overlap fires of others. Position Dragons to kill tanks and BMPs attacking other Dragon positions.

Select alternate positions that can be reached by covered routes. Move to these alternate positions when primary positions are smoked or discovered.

Select covered withdrawal routes that allow a quick return to fighting vehicles.

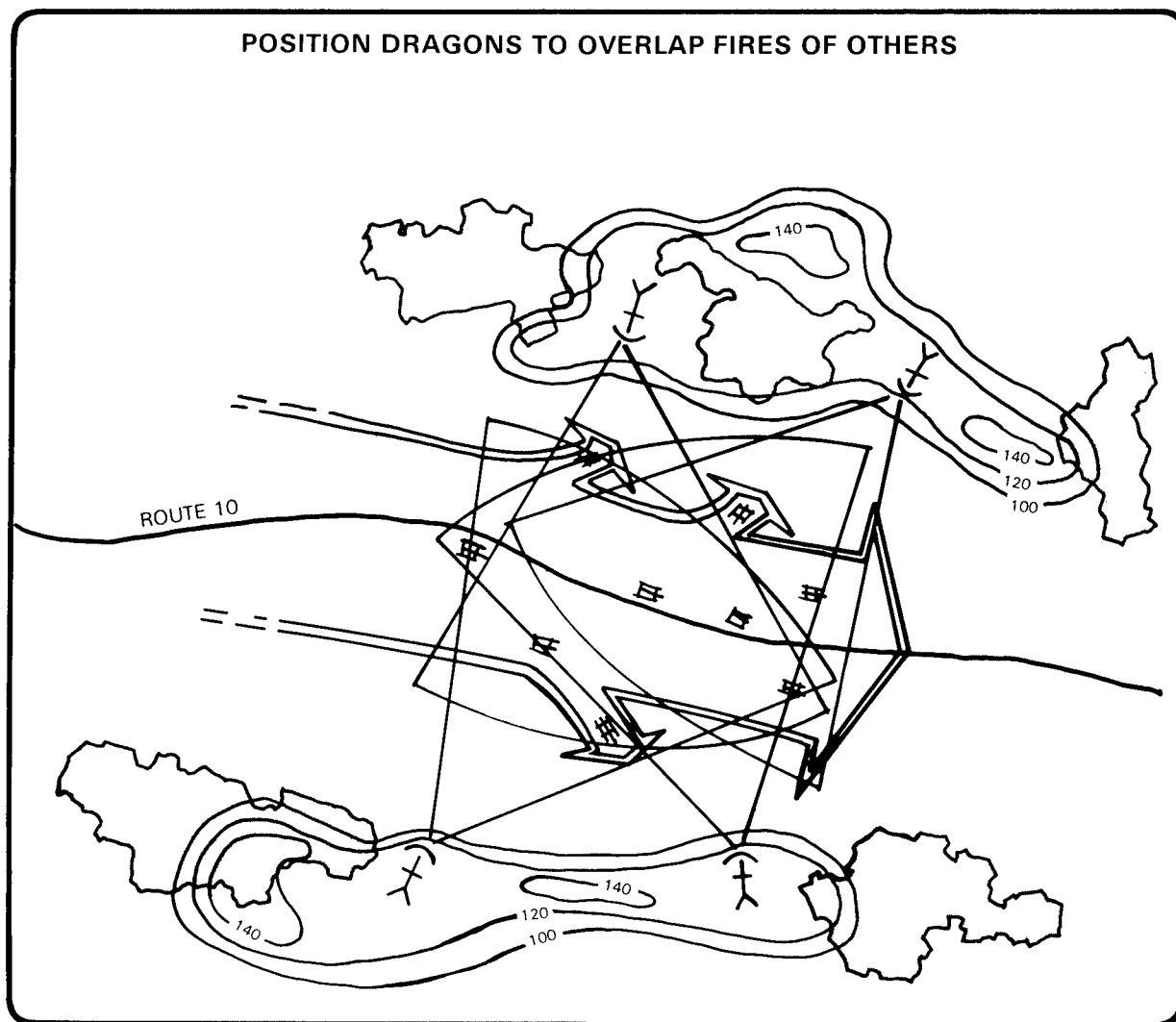

Tanks

Use the armor protection and mobility of tanks to move quickly between hastily prepared positions in front of and on flanks of the enemy.

Position tanks across the avenue of approach as well as the flanks. As the enemy approaches the battle position, tanks across the avenue of approach engage at maximum range. When the enemy moves within range of the tanks and antitank guided missiles (ATGM) located on flanks, the weapons engage.

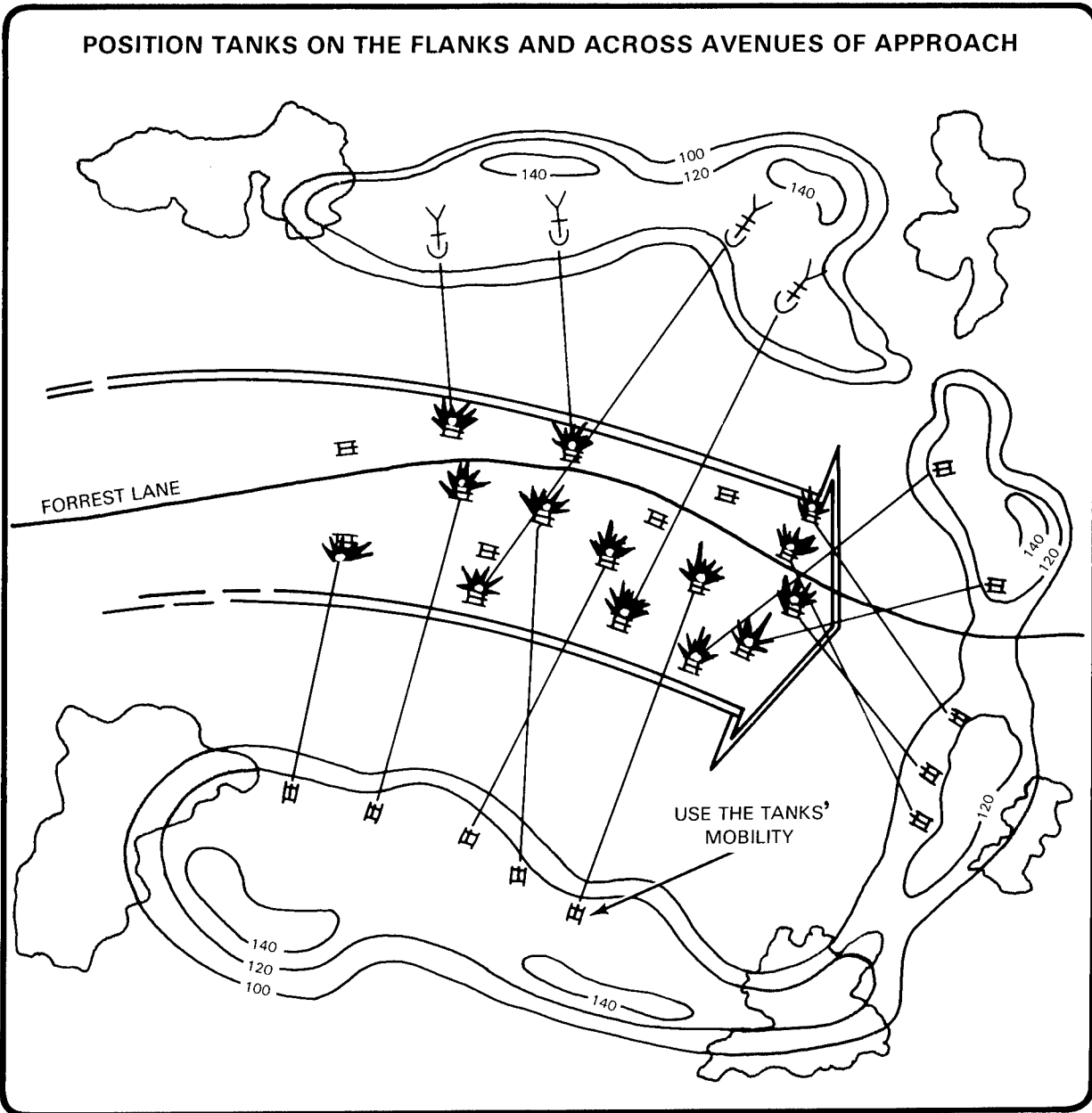

Use crossfire when you're astride enemy avenues of approach.

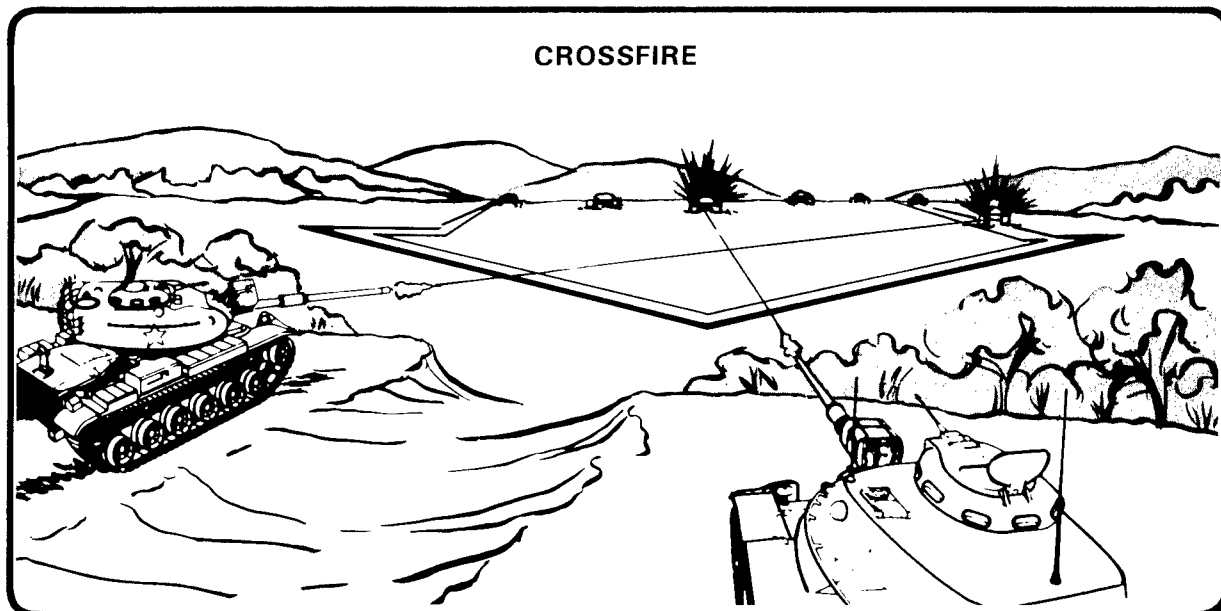

Use depth fire when you're positioned on the flanks.

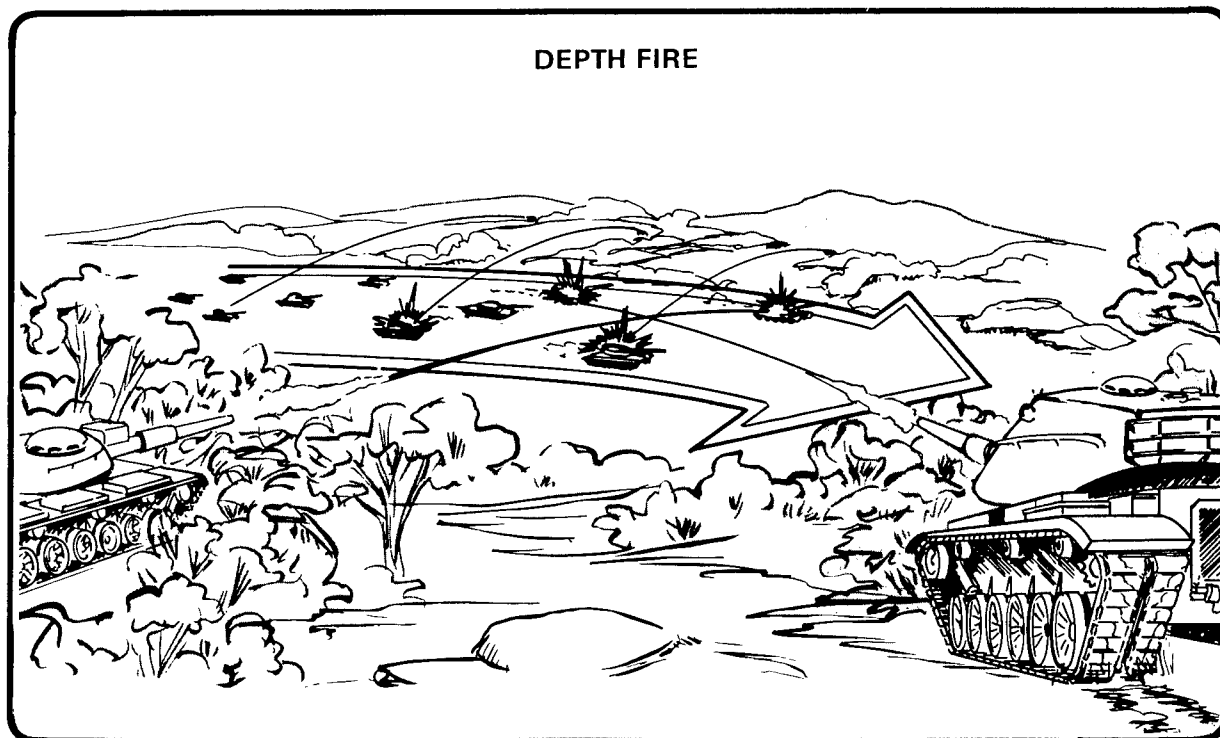

Position tanks on either flank of an avenue of approach so that their fires overlap. *Overlapping fires increase the chances of killing all enemy tanks.* Position tanks so they can move rapidly between positions. Move tanks along covered routes to positions where they can counterattack the enemy with fire.

Select alternate positions that can be reached by covered routes. Move to these alternate positions when primary positions are smoked.

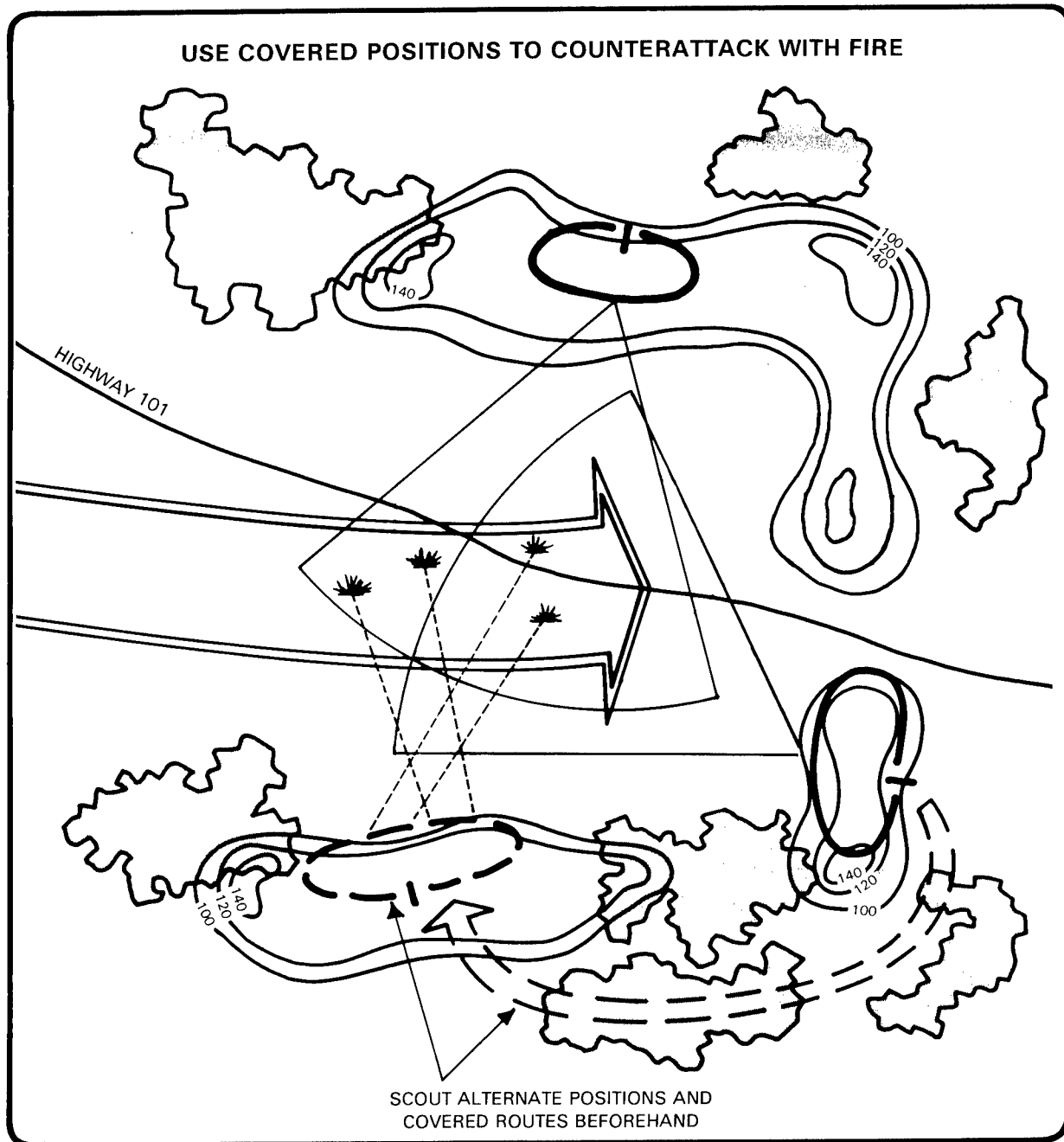

Mines and Obstacles

When tanks and ATGMs cannot be positioned for flank shots because of terrain, use mines and obstacles to make the enemy change direction so his flanks are exposed.

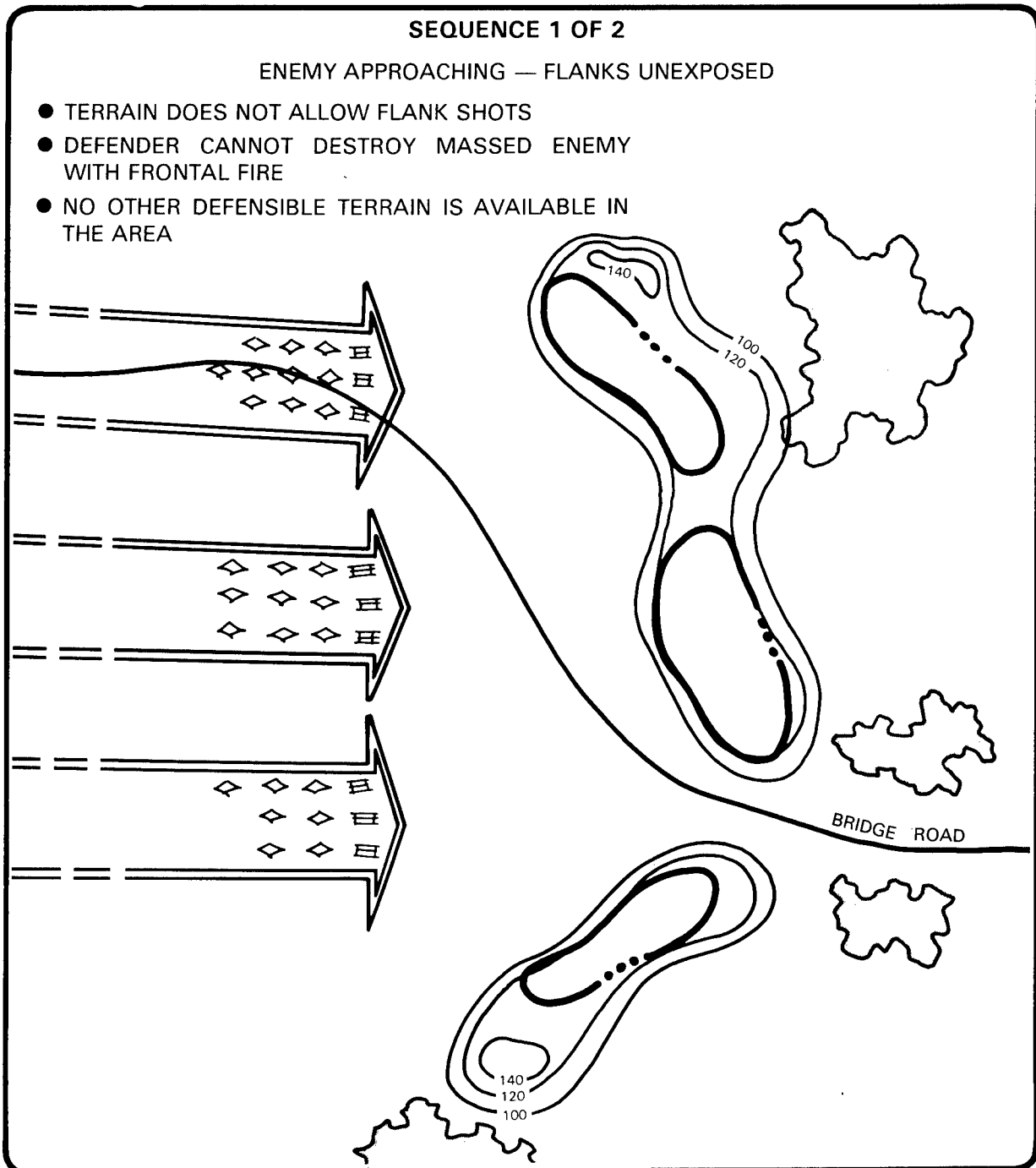

SEQUENCE 2 OF 2

ENEMY DIRECTION CHANGED — MINES HAVE EXPOSED FLANK

- MASS FIRES ON ENEMY MINE ROLLERS AND PLOWS TRYING TO MAKE LANES THROUGH MINEFIELDS
- PLACE MINES AT RANGES WHERE BOTH TANKS AND TOWs CAN KILL ENEMY ARMORED VEHICLES

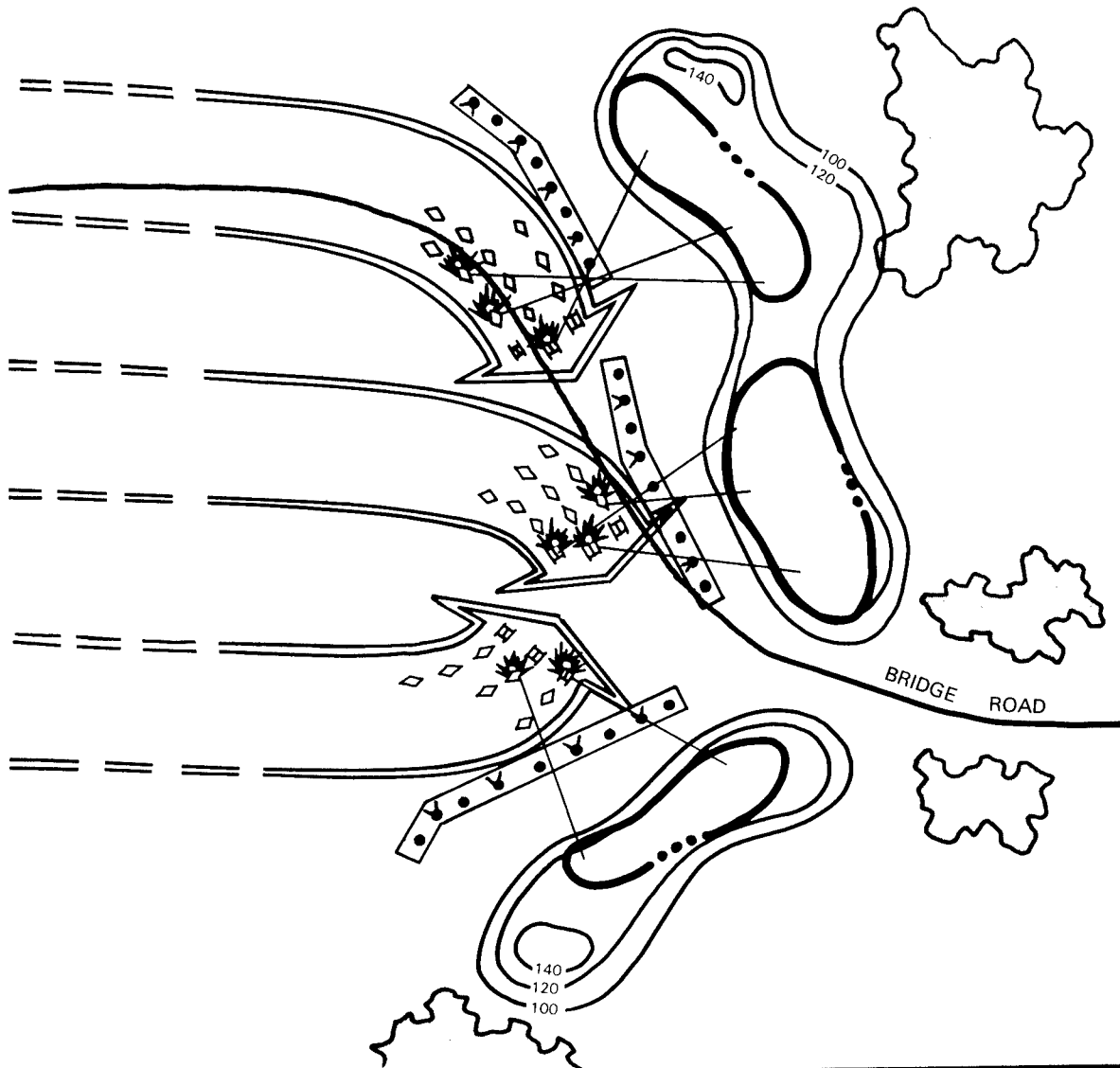

Ordering TRADOC Bulletins

A series of TRADOC Bulletins is being published by HQ TRADOC to provide commanders with timely technical information on weapons, tactics, and training techniques. The bulletins are not intended to supplant doctrinal publications, but to supplement how-to-fight material with data derived from tests, intelligence, or other sources which probe "why?"

TRADOC Bulletins are developed by HQ TRADOC, using the most comprehensive and current military and civilian data available. Army Training and Evaluation Programs (ARTEP), Field Manuals (FM), and Training Circulars (TC) continue to be the primary training references. TRADOC Bulletins supplement them with an explanation of why we are training in a given manner. TRADOC Bulletins should enable commanders to better stimulate and motivate subordinates to understand why we train the way we do.

TRADOC Bulletins are cataloged in DA Pamphlet 310-3 (Index of Doctrinal, Training and Organizational Publications). The series is numbered consecutively, and each TRADOC Bulletin is announced at the time of printing in the information bulletin distributed to all pinpoint account holders by the US Army AG Publications Center.

Additional copies can be requisitioned from the US Army AG Publications Center, Baltimore, MD 21220.

DA Pamphlet 310-10 explains the pinpoint distribution system and how to establish or update an existing account at the US Army AG Publications Center.

TRADOC BULLETIN 12

31 AUGUST 1979



DONN A. STARRY
General, United States Army
Commanding

DISTRIBUTION:

Active Army, USAR, and ARNG: To be distributed in accordance with DA Form 12-11B, Requirements for TRADOC Training Bulletins (Qty rqr block no 432).

Additional copies can be requisitioned from the US Army Adjutant General Publications Center, 2800 Eastern Boulevard, Baltimore, MD 21220.

FEEDBACK — YOUR TURN

TRADOC Bulletins are designed to present timely information on weapons, tactics, and training to units in the field. Bulletins focus on the "why" or rationale for our doctrine. Your response to the questionnaire will help us stay on target.

1. Rank _____ Branch _____ Type Unit _____
 Component _____ (Act, NG, Res)
2. **Are you located at:**
 _____ Company level
 _____ Battalion level
 _____ Brigade level
 _____ Other (specify)
3. **Where did you see this bulletin?**
 _____ Company dayroom
 _____ Orderly room
 _____ Library
 _____ Other (specify)
4. **Did this bulletin (check any or all):**
 _____ Give you info you didn't know before?
 _____ Help in training?
 _____ Provide you with info you received before?
 _____ Convince you that you should do something differently?
5. **Which leaders/soldiers in your units do you think will make best use of this bulletin?**
 _____ E3/E4 _____ PLT LDR _____ BN STAFF
 _____ E5/E6 _____ 1ST SGT _____ BN CDR
 _____ PLT SGT _____ CO CDR _____ OTHER
6. **How will this bulletin be used in your unit?**
7. **Which of these Bulletins have you read?**
 _____ #1 (C) Range and Lethality of US and Soviet Antiarmor Weapons (U)
 _____ #1 (U) Range and Lethality of US and Soviet Antiarmor Weapons
 _____ #2 (C) Soviet ATGMs: Capabilities and Countermeasures (U)
 _____ #2 (U) Soviet ATGMs: Capabilities and Countermeasures
 _____ #3 (C) The Soviet RPG-7 Antitank Grenade Launcher (U)
 _____ #3 (U) The Soviet RPG-7 Antitank Grenade Launcher
 _____ #4 (C) Soviet ZSU 23-4: Capabilities and Countermeasures (U)
 _____ #5 (U) Training with LAW
 _____ #6 (U) Countersurveillance and Camouflage
 _____ #7 (U) The BMP: Capabilities and Limitations
 _____ #9 (U) Infantry Fighting Positions
 _____ #10 (U) Soviet Main Battle Tank: Capabilities and Limitations
 _____ #11 (U) Battle Report: Small Unit Tactics
8. **What other types of Bulletins would help you?**
9. **Other comments:**