

**RUSSIAN AEROSPACE AGENCY**  
Federal State Enterprise  
**Experimental Design Bureau**  
*"Fakel"*

---

181, Moscovsky prosp, Kaliningrad, ,  
236001, Russia  
Fax: 8-(0112) 538-472



**FINAL REPORT ON PROJECT #1590**

**“DEVELOPMENT OF SMALL SPT DEMO MODEL”**

**Project Duration: 01.11.1999 - 30.04.2000.**

**Project Manager:**

**Dr. Arkhipov Boris A.**  
Tel. +7 0112 456600

**Collaborator: Airforce Phyllips Laboratory,  
AFRL/PRRS 4 Draco Drive, CA,USA, 93523**

**Partner: European office of Aerospace Research and Development (EOARD)  
223/231 Old Marylebone Road, London, UK, NW1 5TH**

20010806 098

AQ FOI-11-2188

# REPORT DOCUMENTATION PAGE

Form Approved OMB No. 0704-0188

Public reporting burden for this collection of information is estimated to average 1 hour per response, including the time for reviewing instructions, searching existing data sources, gathering and maintaining the data needed, and completing and reviewing the collection of information. Send comments regarding this burden estimate or any other aspect of this collection of information, including suggestions for reducing this burden to Washington Headquarters Services, Directorate for Information Operations and Reports, 1215 Jefferson Davis Highway, Suite 1204, Arlington, VA 22202-4302, and to the Office of Management and Budget, Paperwork Reduction Project (0704-0188), Washington, DC 20503.

1. AGENCY USE ONLY (Leave blank)		2. REPORT DATE 16-March-2001	3. REPORT TYPE AND DATES COVERED Final Report	
4. TITLE AND SUBTITLE Development Of The Small SPT Demo Model			5. FUNDING NUMBERS ISTC Registration No: 1590	
6. AUTHOR(S) Dr. Boris Arkhipov				
7. PERFORMING ORGANIZATION NAME(S) AND ADDRESS(ES) EDB Fakel. 181 Moskovsky prospekt Kaliningrad (obl.) 236001 Russia			8. PERFORMING ORGANIZATION REPORT NUMBER N/A	
9. SPONSORING/MONITORING AGENCY NAME(S) AND ADDRESS(ES) EOARD PSC 802 BOX 14 FPO 09499-0200			10. SPONSORING/MONITORING AGENCY REPORT NUMBER ISTC 99-7004	
11. SUPPLEMENTARY NOTES				
12a. DISTRIBUTION/AVAILABILITY STATEMENT Approved for public release; distribution is unlimited.			12b. DISTRIBUTION CODE A	
13. ABSTRACT (Maximum 200 words)  This report results from a contract tasking EDB Fakel. as follows: Technical proposal/description of work to achieve the objective of work according to the project it is necessary to solve the following tasks: <input type="checkbox"/> -To develop, manufacture and test the laboratory model of small SPT with thrust efficiency >0.2 under specific impulses (800-1000s) and power consumption ~100 W. Emphasis will be placed upon maximising thrust @ 100 W instead of specific impulse; <input type="checkbox"/> -To manufacture the xenon flow controller (XFC) for the small SPT; <input type="checkbox"/> - To develop, manufacture and test the cathode laboratory model for the small SPT; <input type="checkbox"/> -To integrate the small SPT with cathode and XFC and to provide integrated tests; <input type="checkbox"/> -To prepare technical description and integrated small SPT unit (with cathode and XFC), test at Fakel and to deliver this unit to Edwards AFB for testing. <input type="checkbox"/> Fakel representative will participate in some of the testing at Edwards AFB. Once the tests are complete, the thruster unit will be left at Edwards AFB but will not be re-engineered or disassembled and then reassembled. <input type="checkbox"/> Facilities/Equipment <input type="checkbox"/> To fulfil the tasks presented in Part B, most of the work will conducted at Fakel. Fabrication will be conducted at Fakel's manufacturing capabilities. The test facilities are as follows: <input type="checkbox"/> -the vacuum chamber with diameter not less then 0.9 m and length not less than 1.5 m for the integrated thruster unit tests. <input type="checkbox"/> - the vacuum chamber with diameter not less than 0.5 m and length not less than 1 m for the autonomous cathode and XFC tests. <input type="checkbox"/> -Dynamic pressure during the thruster unit test is to be lower than 3 x 10 <sup>-5</sup> Torr by Xe. <input type="checkbox"/> The thruster will then be tested at Edward's AFB SPT test facility. Fakel assumes no liability for the chamber. <input type="checkbox"/> Schedule of Reports/Deliveries <input type="checkbox"/> Milestone 1 <input type="checkbox"/> Sow acceptance and contract signing. Delivery of design drawings and test plan. <input type="checkbox"/> Payment \$10,000 <input type="checkbox"/> Milestone 2 <input type="checkbox"/> Small SPT unit manufacturing and testing at Fakel <input type="checkbox"/> Time movement: 3 months <input type="checkbox"/> Deliveries: Small SPT unit and its technical results at Fakel <input type="checkbox"/> Payment: \$10,000 within 1 month after delivery <input type="checkbox"/> Milestone 3 <input type="checkbox"/> Small SPT unit testing in USA <input type="checkbox"/> Time movement: 6 months <input type="checkbox"/> Deliveries: Final report - written in conjunction with Edwards personnel based upon their test results <input type="checkbox"/> Payment: \$25,000 within 1 month after report submission				
14. SUBJECT TERMS EOARD			15. NUMBER OF PAGES 15	
			16. PRICE CODE N/A	
17. SECURITY CLASSIFICATION OF REPORT UNCLASSIFIED	18. SECURITY CLASSIFICATION OF THIS PAGE UNCLASSIFIED	19. SECURITY CLASSIFICATION OF ABSTRACT UNCLASSIFIED	20. LIMITATION OF ABSTRACT UL	

## INTRODUCTION

A wide range of scientific and applied tasks can be solved by means of small and micro spacecraft. This trend is now being realized in TechSat21 program. If spacecraft mass is 100 kg then propulsion system should have a mass of ~ 10 kg and a power of about 100 W. For this purpose electric thrusters of various types can be used. The use of small stationary plasma thruster (SPT) is promising. Demonstration test results of such a thruster are adduced in this report.

After the first stage of the demonstration test [2] the anode unit, cathode unit and flow control unit were assembled as a monoblock unit – a small SPT. The purpose of testing was to check the small SPT for compliance with the 1590p project requirements:

- full power - 100 W;
- anode efficiency (without taking into account the cathode flow rate) > 20%;
- specific impulse (without taking into account the cathode flow rate) > 800 s.

## STRUCTURE DESCRIPTION

Overall and mounting dimensions of the small SPT are shown in Fig. 1. The thruster unit consists of the SPT-25 anode unit, the BNK-0.5 heaterless cathode, the FCU-0.5 flow control unit and a common plate. Mass of the thruster unit is 740g. General view of the small SPT laboratory model is shown in Fig. 2.

Electropneumatic circuit diagram of the test is shown in Fig. 3. To initiate the discharge in the heaterless cathode the ignition unit laboratory model was used.

## TEST RESULTS

Fig. 4 shows the view of operating thruster.

The volt-ampere characteristic at the 3 levels of flow rate are adduced in Table 1. Operating time at final test was 9 h.

# RESULTS FINALS TESTES

Volt-ampere characteristic at 3 level flow rate Table 1

N	Ud	Id	F	~Ud	Ic	Uc	PFCU	Ift	Uft	Ucg	G	Pv	Na	Nu	Ispa	Ispu	Efa	Efu
V	A	A	mN	V	A	V	kPa	A	V	V	mg/s	Torr	W	W	s	s	%	%
1	92	0,630	2,23	3,60	1,30	0,605	110	2,39	0,97	13,9	0,62	4,7E-05	58,7	61,8	428	367	8,0	6,5
2	101	0,650	2,72	3,00	1,30	0,605	110	2,39	0,97	13,9	0,62	4,7E-05	66,4	69,5	522	447	10,5	8,6
3	110	0,655	3,19	2,65	1,30	0,600	110	2,39	0,97	14,1	0,62	4,7E-05	72,8	75,8	611	524	13,1	10,8
4	120	0,645	3,48	2,65	1,30	0,600	110	2,39	0,97	14,6	0,62	4,7E-05	78,2	81,2	668	572	14,6	12,0
5	129	0,645	3,9	3,00	1,30	0,600	110	2,39	0,97	14,9	0,62	4,7E-05	84,0	87,0	748	641	17,0	14,1
6	141	0,650	4,32	4,00	1,30	0,595	110	2,39	0,97	15,1	0,62	4,7E-05	92,4	95,4	828	709	19,0	15,7
7	150	0,660	4,68	4,20	1,30	0,595	110	2,39	0,97	15,2	0,62	4,7E-05	99,8	102,8	898	770	20,7	17,2
8	160	0,675	4,98	4,40	1,30	0,605	110	2,39	0,97	14,9	0,62	4,7E-05	108,8	111,8	955	818	21,4	17,9
9	171	0,695	5,27	5,80	1,30	0,610	110	2,39	0,97	14,5	0,62	4,7E-05	119,6	122,7	1011	867	21,9	18,3
10	180	0,710	5,27	30,00	1,30	0,610	110	2,39	0,97	13,9	0,62	4,7E-05	128,6	131,6	1011	867	20,3	17,0
11	191	0,725	5,25	36,00	1,30	0,615	110	2,39	0,97	13,6	0,62	4,7E-05	139,3	142,3	1006	863	18,6	15,6
12	200	0,740	5,42	38,00	1,30	0,615	110	2,39	0,97	13,3	0,62	4,7E-05	148,8	151,8	1039	891	18,6	15,6
1	100	0,740	3,11	2,75	1,30	0,630	110	2,11	0,84	12,5	0,69	4,9E-05	74,8	77,3	537	460	11,0	9,1
2	120	0,730	4,05	2,70	1,30	0,625	110	2,11	0,84	13,2	0,69	4,9E-05	88,4	90,9	697	598	15,7	13,1
3	150	0,750	5,32	4,70	1,30	0,625	110	2,11	0,84	13,5	0,69	4,9E-05	113,3	115,8	917	786	21,1	17,7
4	170	0,790	6,01	4,20	1,30	0,630	110	2,11	0,84	13,2	0,69	4,9E-05	135,1	137,6	1035	887	22,6	19,0
1	140	0,540	3,56	2,00	1,30	0,640	110	2,82	1,17	16,7	0,56	4,3E-05	76,4	80,4	755	647	17,2	14,0
2	150	0,550	3,85	3,20	1,30	0,635	110	2,82	1,17	16,4	0,56	4,3E-05	83,3	87,3	817	701	18,5	15,2
3	160	0,560	4,14	4,80	1,30	0,640	110	2,82	1,17	16,6	0,56	4,3E-05	90,4	94,4	880	754	19,8	16,2
4	170	0,580	4,29	22,00	1,30	0,645	110	2,82	1,17	15,9	0,56	4,3E-05	99,4	103,4	911	781	19,3	15,9
5	181	0,590	4,1	34,00	1,30	0,645	110	2,82	1,17	15,4	0,56	4,3E-05	107,6	111,6	869	745	16,2	13,4
6	191	0,605	4,24	38,00	1,30	0,645	110	2,82	1,17	15,2	0,56	4,3E-05	116,4	120,4	901	772	16,1	13,4
7	200	0,615	4,44	39,00	1,30	0,645	110	2,82	1,17	15,0	0,56	4,3E-05	123,8	127,8	942	808	16,6	13,8
8	209	0,625	4,64	40,00	1,30	0,650	110	2,82	1,17	14,8	0,56	4,3E-05	131,5	135,5	984	843	17,0	14,2
9	220	0,640	4,78	41,00	1,30	0,650	110	2,82	1,17	14,5	0,56	4,3E-05	141,6	145,6	1015	870	16,8	14,0

List of parameters adduced in Table 1:  $U_d$  - discharge voltage;  $I_d$  - discharge current;  $F$  - thrust;  $\sim U_d$  - discharge voltage oscillation;  $I_c$  - magnetic coil current;  $U_c$  - coil voltage;  $P_{FCU}$  - pressure at the FCU inlet;  $I_{tt}$  - thermothrottle current;  $U_{tt}$  - thermothrottle voltage;  $U_{cg}$  - cathode-to-ground voltage;  $G$  - total Xenon flow rate;  $P_v$  - pressure in the vacuum chamber (by air);  $N_a$  - anode unit power;  $N_u$  - total power of the SPT unit;  $I_{spa}$  - specific impulse without taking into account the cathode flow rate;  $I_{spu}$  - specific impulse;  $E_{fa}$  - thruster efficiency;  $E_{fu}$  - total efficiency of the thruster unit.

$I_{spa}$ ,  $I_{spu}$ ,  $E_{fa}$ ,  $E_{fu}$ ,  $N_a$  and  $N_u$  parameters were calculated in accordance with the equations adduced in the report [2]. Main parameters have agreed with ones obtained previously.

## CONCLUSION

1. The scheduled work has been executed in full.
2. Small SPT parameters comply with the requirements specified.
3. An ignition unit is supplied as part of small SPT. The small SPT is prepared for demonstration test at Customer's facilities.

## REFERENCES

1. R.A. Spores, M. Bircan, The USAF Electric Propulsion Program. IEPC-99-009.
2. Presentation and demonstration test of flow control system and the cathode for the small SPT. Technical report. (Project 1590p)

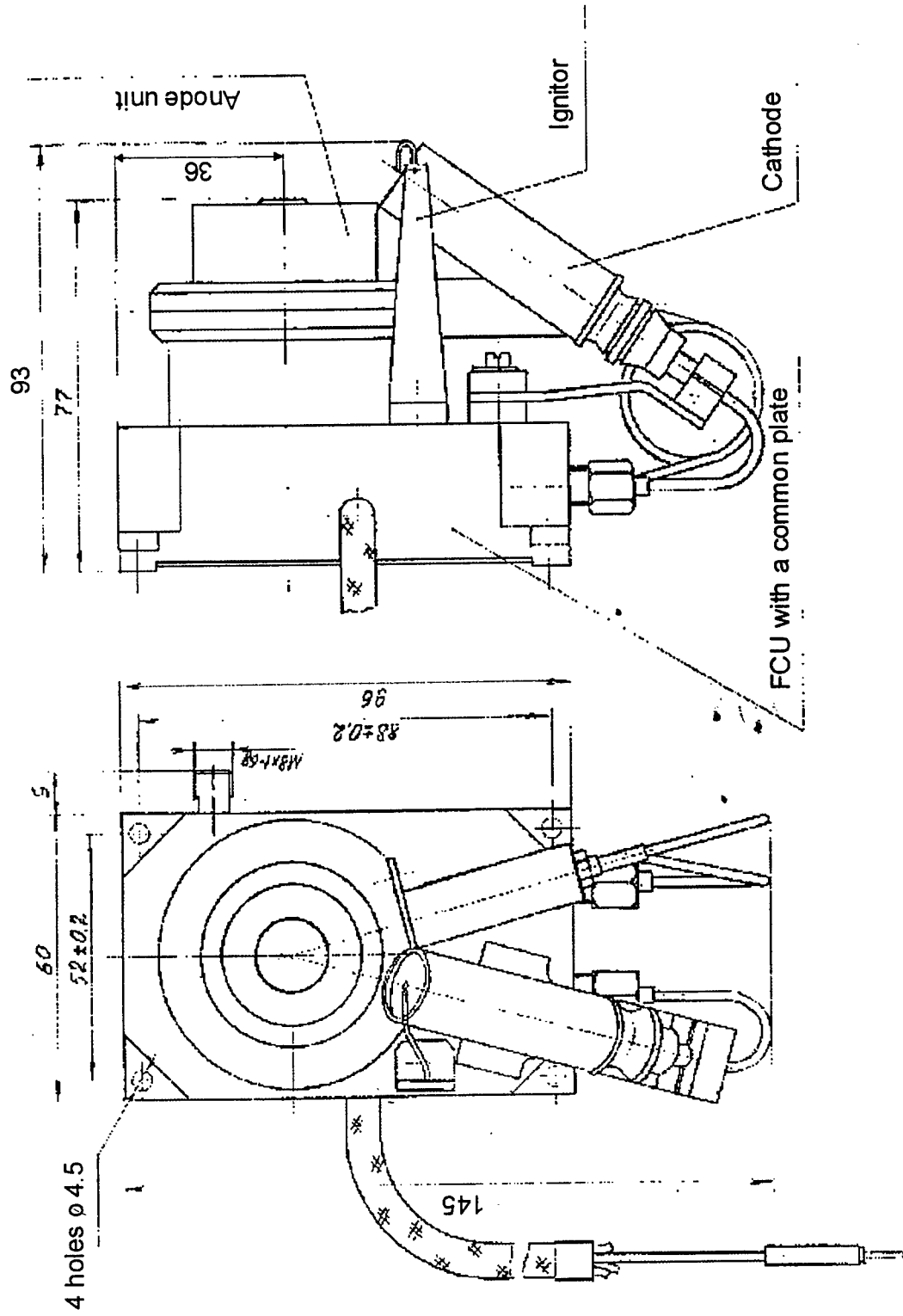

Fig. 1 Overall dimensions of small SPT

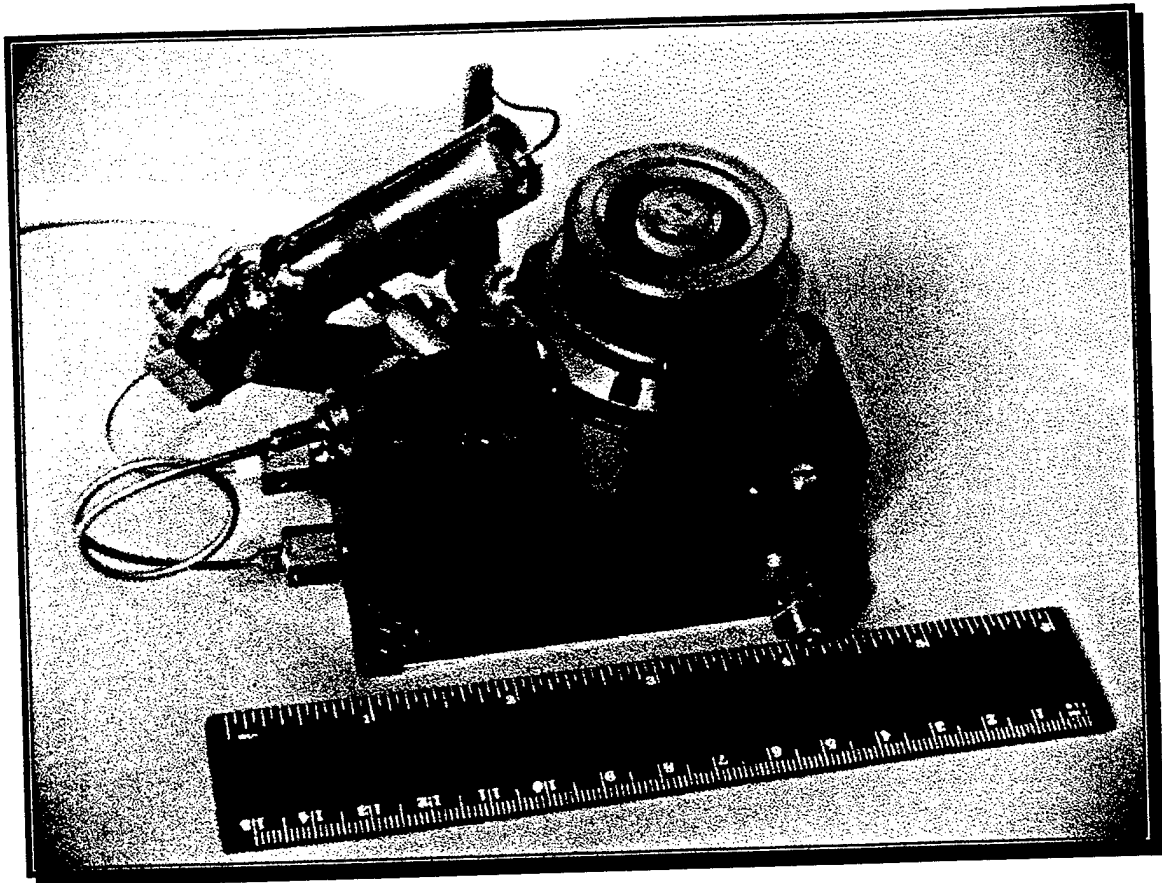

Fig. 2 Small SPT general view

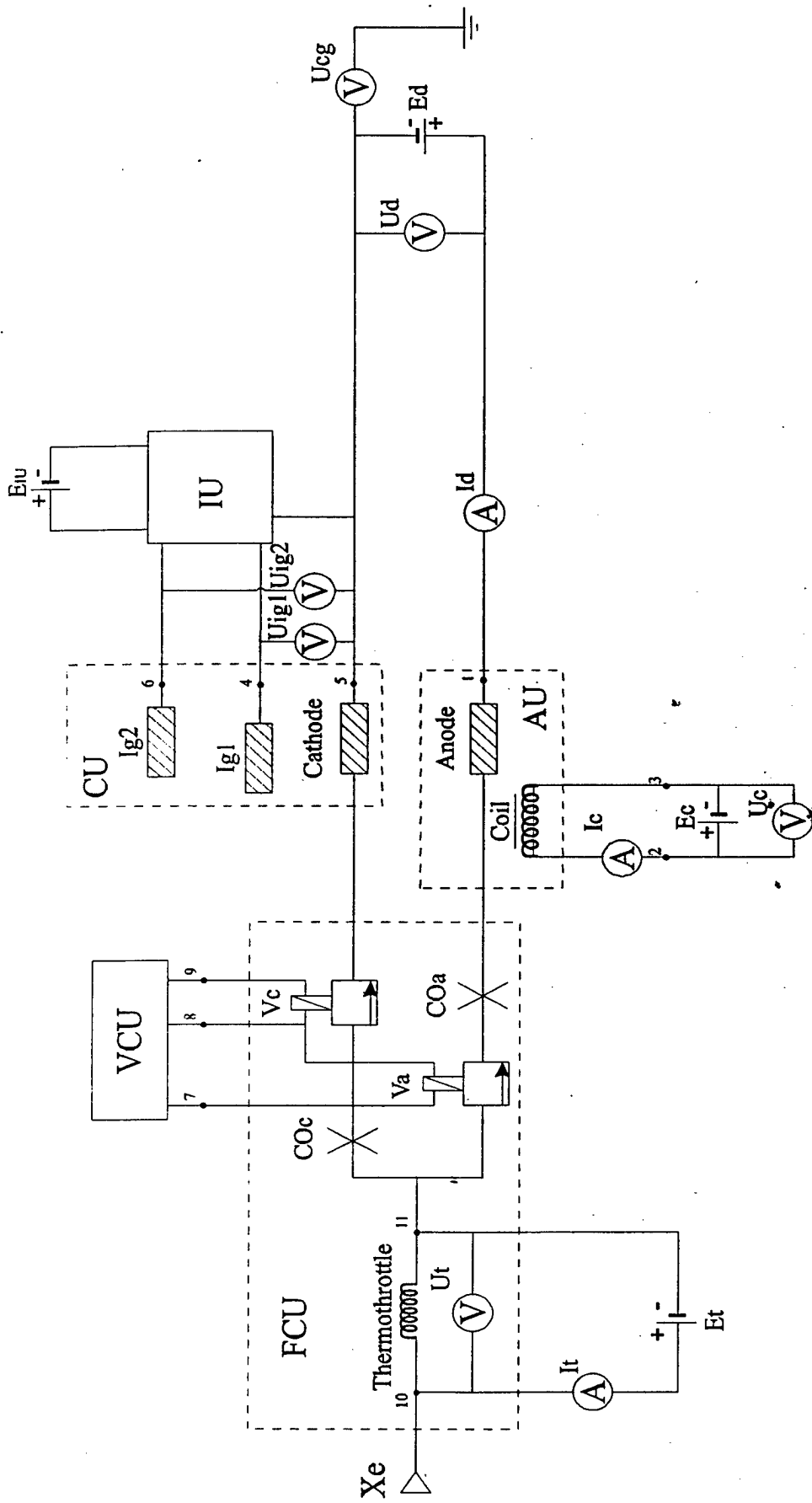

Fig.3. Pneumoelectric circuit diagram of the small SPT-25  
 FCU - flow control unit, CU - cathode unit, VCU - valve  
 control unit, IU - ignition unit, AU - anode unit



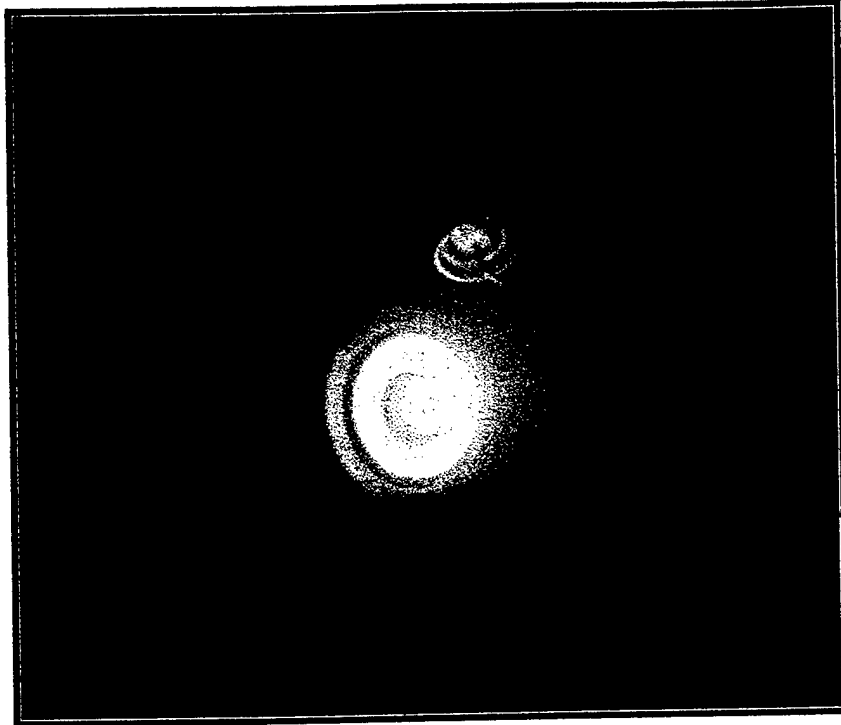
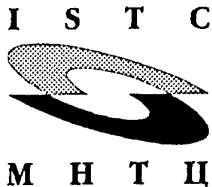

Fig. 4 View of operating thruster

INTERNATIONAL  
SCIENCE AND TECHNOLOGY  
CENTER

Luganskaya ulitsa, 9  
PO Box 25, 115516 Moscow,  
Russian Federation  
Tel: +7 (095/501) 797-6010  
Fax: +7 (095/501) 797-6047  
E-mail: [istcinfo@istc.ru](mailto:istcinfo@istc.ru);  
<http://www.istc.ru>



МЕЖДУНАРОДНЫЙ  
НАУЧНО-ТЕХНИЧЕСКИЙ  
ЦЕНТР

Луганская улица, 9  
А/Я 25, 115516 Москва,  
Российская Федерация  
Тел: +7 (095/501) 797-6010  
Факс: +7 (095/501) 797-6047  
E-mail: [istcinfo@istc.ru](mailto:istcinfo@istc.ru);  
<http://www.istc.ru>

## ISTC PROJECT COMPLETION STATEMENT

#1590p

### TITLE OF THE PROJECT:

Development of Small SPT Demo Model

### EXECUTIVE DIRECTOR'S STATEMENT:

The aforementioned ISTC project is completed. The consolidated Cost Statement has been audited and the overhead payment has been released. Please find enclosed a copy of:

1. Summary of the Final Project Report;
2. Evaluation by the Secretariat of the Final Project Report;
3. Consolidated Cost Statement.

A handwritten signature in black ink, appearing to read 'Michael Kröning', is written over a horizontal line.

Michael Kröning, Executive Director

Date: 30.11.20

**EVALUATION FORM FOR FINAL REPORTS OF ISTC PROJECTS**

Project Attributes	
<b>Project Number</b>	1590p
<b>Project Title</b>	Development of Small SPT Demo Model
<b>Leading Institute</b>	Experimental Design Bureau Fakel, Kaliningrad, Kaliningrad Reg., Russia
<b>Project Manager</b>	Arkhipov Boris
<b>O.C.D.</b>	01 November 1999
<b>Duration</b>	4 months
<b>Total Budget</b>	\$ 35,000
<b>Funding Parties</b>	United States Air Force / The European Office of Aerospace Research and Development, London, UK
<b>ISTC Project Manager</b>	S. Karabashev
<b>ISTC Deputy Executive Director</b>	S. Zykov
Major Technical Accomplishment	
<b>I. Accomplishment of all tasks of the Work Plan</b>	
<p>The main results of the project can be summarized as follows:</p> <ol style="list-style-type: none"> <li>1) A small SPT(stationary plasma thruster) demo model was developed, manufactured and tested.</li> <li>2) The small SPT demo model consists of:               <ul style="list-style-type: none"> <li>- SPT-25 laboratory model of the thruster;</li> <li>- Cathode;</li> <li>- Flow control unit (FCU).</li> </ul> </li> <li>3) Each part of the small SPT demo model has successfully undergone autonomous tests and the declared performance level has been confirmed.</li> <li>4) The assembled small SPT demo model has undergone demonstration tests and showed compliance with specified requirements, as follows:               <ul style="list-style-type: none"> <li>- thrust efficiency <math>\eta_r \geq 0.2</math>, calculated without cathode mass flow rate;</li> <li>- specific impulse (800-1000)s, calculated without cathode mass flow rate;</li> <li>- power ~100W.</li> </ul> </li> <li>5) The small SPT demo model was delivered to the Partner for demonstration tests.</li> </ol>	

<b>II. Published Papers, Presentations, Trips (Conferences, Meetings).</b>
Data obtained in the project have not been published
<b>III. Collaboration between CIS Institutes.</b>
The project was performed by one Institution.
<b>IV. Partnership with Foreign Institutes.</b>
This is a partner project.
<b>V. Technology Implementation Plan.</b>
This is a partner project.
<b>Financial Monitoring</b>
The audited Consolidated Cost Statement is attached.
Overhead payment has been made in accordance with the results of the final audit.
<b>Equipment and Materials</b>
In total \$990.39 was spent on materials
<b>Technical Monitoring</b>
I. On-site monitoring was performed at the Experimental Design Bureau Fakel. No major deviations from the Work Plan or ISTC project management regulations were identified.
<b>Other Comments</b>

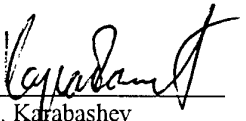
  
 S. Karabashev  
 Senior Project Manager  
 Date: 20.11.007

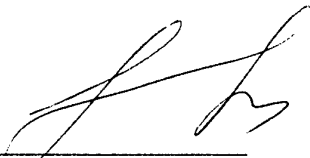
  
 S. Zykov  
 Deputy Executive Director  
 Date: 21.11.00

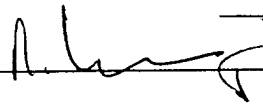
<b>I S T C</b>  <b>M H T U</b>	<b>International Science and Technology Center</b> <b>Vendor Payment Request</b>		
Invoice Number:	IN-P - 1590	ADM or Project Num.	P 1590
For Institute/City	CDB "Fakel" , Kaliningrad		QR
Payee Name and Address:	_____		
Contract/Invoice Num.	_____		
Details	Overhead Disbursement		
Terms	(Single PMT/ Multy stage PMT)		
Amount to be Paid and Distributed	\$	407.95	Currency
Requested by Allotment Manager	_____		Date
Title/Name	Dr. Michael Kroening, ED		 3, 11, 00

*Accounting Information (to be filled by Finance Office Staff)*

Budget Control Officer			
Title/Name			
Date Received		Invoice Number:	
ACCPAC input (AP-Invoice- Document Type = Invoice; Purchase=Bank ACCT)			
Job-Phase- Category	Amount	Account Num For Admin Only	Amount
P1590 - ZY - 7AA1	407.95		
-	-		
-	-		
-	-		
-	-		
Exchange Rate :		TOTAL \$	407.95
Input Date		; Batch Num	Inputted by
<b>Payment Processing</b>			
Bank Code (Check one)	BTC	CONV/DOLL	CONV/RUB
Date	_____	Amount	_____ USD/RBL
DETAILS			
BATCH Num	Initial	PMT Approved: Initial Date	
ACCPAC input		(AP-Payment- Document Type =Manual Check)	
Input Date	; Batch Num	Check Num	Inputted by

Institute CDB Fakel, Kaliningrad

Project 1590

**FINAL FINANCIAL REPORT BY AUDIT. ADJUSTMENTS.**

Reporting period: November, 01, 1999 - April, 30, 2000

QR

	Cost Category	Accumulated Cost per Recipient Report		Accumulated Cost per Audit		Adjustments	
		(1)	(2)	(1)	(2)	(1)	(2)
1	GRANT PAYMENTS						
	Category - I		21,500.00		21,500.00		0.00
	Category - II		9,400.00		9,400.00		0.00
	Category - III						
	Category - IV		920.00		920.00		0.00
	Total Grant Payments		31,820.00		31,820.00		0.00
2	Equipment:						
1	Modifications						
2	Capital Equipment						
3	Non-Capital Equipment						
4	Leased Equipment						
5	Maint & Repair						
	Including VAT						
	Total Equipment						
3	MATERIALS						
1	Materials	470.04	990.39	470.04	990.39	0.00	0.00
2	Supplies						
3	Safety Devices						
4	Other						
	Including VAT						
	Total Materials	470.04	990.39	470.04	990.39	0.00	0.00
4	BANK FEES	3.35	135.50	3.36	141.35	0.01	5.85
5	OTHER DIRECT COSTS						
1	Technological Energy						
2	Reports/Publishing						
3	Communications						
4	Admin. Supplies						
5	Other						
	Including VAT						
	Total ODC						
6	TRAVEL/PER DIEM						
	Local-Russia-CIS	429.60		432.66		3.06	
	Outside CIS						
	Total Travel & Per Diem	429.60		432.66		3.06	
7	Exchange rates gains/losses	-7.65	6.31	-10.72	6.31	-3.07	0.00
8	Overhead		0.00		738.66		738.66
	TOTAL	895.34	32,952.20	895.34	33,696.71	0.00	744.51
	TOTAL VAT INCLUDED						
	GRANDTOTAL		33,847.54		34,592.05		744.51

Remarks: \* (1) - Cash flow through Recipient Account

\*\* (2) - Cash flow through ISTC

ISTC Auditor  
Timur Timerbaev*Т. Тимурбаев*

30 OCT 2000

Institute CDB Fakel, Kaliningrad

Project 1590

## FINAL FINANCIAL REPORT BY AUDIT. RESIDUALS

Reporting period: November, 01, 1999 - April, 30, 2000

QR

Cost Category	Budget TOTAL		Accumulated Cost		Funds Residuals	
	(1)	(2)	(1)	(2)	(1)	(2)
1 GRANT PAYMENTS						
Category - I		21,500.00		21,500.00		0.00
Category - II		9,000.00		9,400.00		-400.00
Category - III						
Category - IV		720.00		920.00		-200.00
Total Grant Payments		31,220.00		31,820.00		-600.00
2 Equipment:						
1 Modifications						
2 Capital Equipment						
3 Non-Capital Equipment						
4 Leased Equipment						
5 Maint & Repair						
Including VAT						
Total Equipment						
3 MATERIALS						
1 Materials	0.00	1,000.00	470.04	990.39	-470.04	9.61
2 Supplies						
3 Safety Devices						
4 Other						
Including VAT						
Total Materials	0.00	1,000.00	470.04	990.39	-470.04	9.61
4 BANK FEES	4.50	157.50	3.36	141.35	1.14	16.15
5 OTHER DIRECT COSTS						
1 Technological Energy						
2 Reports/Publishing	500.00		0.00		500.00	
3 Communications						
4 Admin. Supplies						
5 Other						
Including VAT						
Total ODC	500.00		0.00		500.00	
6 TRAVEL/PER DIEM						
Local-Russia-CIS	400.00		432.66		-32.66	
Outside CIS						
Total Travel & Per Diem	400.00		432.66		-32.66	
7 Exchange rates gains/losses			-10.72	6.31	10.72	-6.31
8 Overhead		0.00		738.66		-738.66
TOTAL	904.50	32,377.50	895.34	33,696.71	9.16	-1,319.21
TOTAL VAT INCLUDED						
GRANDTOTAL		33,282.00		34,592.05		-1,310.05

Remarks: \*(1) - Cash flow through Recipient Account

\*\* (2) - Cash flow through ISTC

ISTC Auditor  
Timur Timerbaev*Т. Тимурбаев*

30.04.2000

Наименование Рабочей Бумаги	<b>РАСЧЕТ СУММЫ НАКЛАДНЫХ РАСХОДОВ К ВЫПЛАТЕ</b>
Проверку проводил: Тимурбаев Т.Ф.	
Дата: 22 июня 2000 г.	

Проект 1590 P  
 Институт ОКБ "Факел", гор. Калининград QR

	Сумма	Формула	Комментарий
Всего произведено затрат (1)	895.34	k	Включая: сумму накладных расходов в сумме \$ 730,00 + остаток на счете \$ 8,66 (см. разъяснения ниже)
Всего произведено затрат (2)	33.696.71	l	
Итого <b>ФАКТИЧЕСКИХ</b> прямых затрат по проекту	34.592.05	m=k+l	
Итого <b>ПЛАНОВЫХ</b> прямых затрат по проекту	32.562.00	n	

**Если фактических прямых затрат больше, чем плановых  $m > n$**  I

Общая стоимость проекта	35.000.00	o	
Затраты (1) подлежащие компенсации	0.00	t	
Остаток средств на счете	0.00	d	
Начисленные Накладные	0.00	u=o-m	
<b>Накладные расходы + компенсация по прямым затратам к выплате</b>	<b>0.00</b>	<b>p=u+t-d</b>	

**Если фактические прямые затраты меньше или равны, плановым  $m \leq n$**  II

Плановые накладные расходы	2.438.00	r	
Затраты (1) подлежащие компенсации	895.34	t	
Остаток средств на счете	8.66	d	Остаток на банковском счете (российские рубли) составил RUB 247.67. Курс МНТЦ на 01.04.2000 составляет 28.60 руб. за \$ 1.
Начисленные Накладные *	407.95	u=r	
<b>Накладные расходы + компенсация по прямым затратам к выплате</b>	<b>1,294.63</b>	<b>s=u+t-d</b>	

<b>Общая экономия средств по проекту **</b>		$x=o-m-u$	Сэкономленные средства перечислены на УСС (130110) соответствующих сторон
---	--	-----------	---

\* Использован следующий расчет:  $35.000.00 - 33.862.05 - 730.00 = 407.95$ , где **35,000.00** общая стоимость проекта, **33,862.05** расходы проекта за весь период. **730.00** - часть суммы *накладных расходов*, уже использованных ОКБ "Факел" для отправки экспериментальных образцов коллаборатору проекта 1590.

\*\* Реально экономии по проекту нет: формула ISTC F-A8 не учитывает \$ 730.00, а также \$ 8.66 (см. ссылку \*)

*Т. Тимурбаев*