

REPORT DOCUMENTATION PAGE

Form Approved
OMB NO. 0704-0188

Public Reporting burden for this collection of information is estimated to average 1 hour per response, including the time for reviewing instructions, searching existing data sources, gathering and maintaining the data needed, and completing and reviewing the collection of information. Send comment regarding this burden estimate or any other aspect of this collection of information, including suggestions for reducing this burden, to Washington Headquarters Services, Directorate for Information Operations and Reports, 1215 Jefferson Davis Highway, Suite 1204, Arlington, VA 22202-4302, and to the Office of Management and Budget, Paperwork Reduction Project (0704-0188), Washington, DC 20503.

| | | |
|----------------------------------|---------------------------------|---|
| 1. AGENCY USE ONLY (Leave Blank) | 2. REPORT DATE Dec. 29, 2000 | 3. REPORT TYPE AND DATES COVERED FINAL 01 Jul 00 - 31 Dec 00 |
|----------------------------------|---------------------------------|---|

| | |
|---|--|
| 4. TITLE AND SUBTITLE Prototype of On-Chip Signal Processing for Handheld Chemical Agent Sensors | 5. FUNDING NUMBERS DAAD19-00-1-0437 |
|---|--|

| |
|---|
| 6. AUTHOR(S) Charles S. Ih & Baohua Zhuang |
|---|

| | |
|--|--|
| 7. PERFORMING ORGANIZATION NAME(S) AND ADDRESS(ES) University of Delaware | 8. PERFORMING ORGANIZATION REPORT NUMBER |
|--|--|

| | |
|--|---|
| 9. SPONSORING / MONITORING AGENCY NAME(S) AND ADDRESS(ES) U. S. Army Research Office P.O. Box 12211 Research Triangle Park, NC 27709-2211 | 10. SPONSORING / MONITORING AGENCY REPORT NUMBER ARO 41488.0-CH-II |
|--|---|

11. SUPPLEMENTARY NOTES
The views, opinions and/or findings contained in this report are those of the author(s) and should not be construed as an official Department of the Army position, policy or decision, unless so designated by other documentation.

| | |
|---|-------------------------|
| 12 a. DISTRIBUTION / AVAILABILITY STATEMENT Approved for public release; distribution unlimited. | 12 b. DISTRIBUTION CODE |
|---|-------------------------|

13. ABSTRACT (Maximum 200 words)

Two systems of the on-chip signal processing for handheld chemical agent sensors have been investigated. The principle of one on-chip signal processing is dependent on the resistance changes of the chemical sensor or chemical materials. The other principle is dependent on the impedance test. One prototype was built and delivered. The other three prototypes can be demonstrated. Two detection/amplification concepts were explored. The resolution of the relative resistance measurement is better than 10⁻⁶. Suggestions for the future development are proposed.

20010222 014

| | |
|-------------------|---------------------|
| 14. SUBJECT TERMS | 15. NUMBER OF PAGES |
| | 16. PRICE CODE |

| | | | |
|---|--|---|----------------------------------|
| 17. SECURITY CLASSIFICATION OR REPORT UNCLASSIFIED | 18. SECURITY CLASSIFICATION ON THIS PAGE UNCLASSIFIED | 19. SECURITY CLASSIFICATION OF ABSTRACT UNCLASSIFIED | 20. LIMITATION OF ABSTRACT UL |
|---|--|---|----------------------------------|

Final Report

On

Prototype of On-Chip Signal Processing for Handheld Chemical Agent Sensors

Dec. 29, 2000

Submitted to

Director

U.S. Army Research Office

ATTN: AMXRO-ICA

P.O. Box 12211

Research Triangle Park, NC 27709-2211

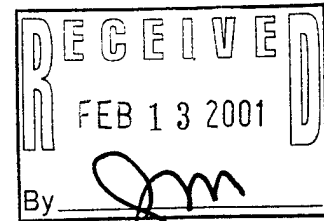

2001 FEB 12 PM 4: 17

By Charles S. Ih & Baohua Zhuang

Department of Electrical & Computer Engineering

University of Delaware

Newark DE 19716

Abstract

Two systems of the on-chip signal processing for handheld chemical agent sensors have been investigated. The principle of one on-chip signal processing is dependent on the resistance changes of the chemical sensor or chemical materials. The other principle is dependent on the impedance test. One prototype was built and delivered. The other three prototypes can be demonstrated. Two detection/amplification concepts were explored. The resolution of the relative resistance measurement is better than 10^{-6} . Suggestions for the future development are proposed.

41488

Primary Goals

The primary goals related to the study of the **Prototype of on-chip signal processing for handheld chemical agent sensors** are the following:

1. To investigate the detector/ amplifier techniques for chemical agent sensors.
2. To demonstrate the feasibility of the signal processing unit.
3. To design and build a prototype of the on-chip signal processing for handheld chemical agent sensors.
4. To test the signal processing prototype with the chemical agent sensors using conductive polymer developed at the Army Research Laboratory in Aberdeen, Maryland.
5. To deliver a prototype of the signal conditioning and amplifying device that is suitable for handheld applications for evaluation purposes.

Summary of accomplishment

1. Investigated two detection/amplification approaches. One of the on-chip signal processing approach is to detect the resistance changes of the chemical sensor. The other is to evaluate the impedance changes of the chemical sensors.
2. Demonstrated the on-chip signal processing concepts using the Lock-in Amplifier Model 128, fabricated by *EG&G* Company.
3. Designed and fabricated four prototypes of on-chip signal processing unit for handheld chemical agent sensors:
 - (1) CST-2 Chemical Sensor Resistance Tester
 - (2) CSIT-1 Chemical Sensor Impedance Tester
 - (3) CST-1 AC Chemical Sensor Resistance Tester
 - (4) Miniature Chemical Sensor Alarm
4. Tested three Prototypes (1) to (3) with the chemical agent sensors using conductive polymer developed at the Army Research Laboratory in Aberdeen, Maryland.
5. One prototype CST-2 Chemical Sensor Resistance Tester was delivered and the other three have been demonstrated. The resolution of the relative resistance measurement is better than 10^{-6} . The sizes are 3.25" x 4.38" x 1.5" for the Prototypes (1) to (3), and 1.38" x 2.12" x 0.58" for Prototype (4).
6. More advanced signal processing methods have been suggested in anticipation in rapid improvement of the CMOS technology.

1. Introduction

The development of chemical agent sensors capable of discrimination of different analytes, toxins, and bacteria has become increasingly important for military, environmental, medicinal, food processing/evaluation, health and safety, remote sensing, and chemical processing applications. A recent advance in modern microelectronics is the ability of micro chemical laboratory and bio-sensors on a chip [1]. It has made many new applications in chemical and bio-sensors practical, such as hand-held devices for detecting different chemical agents in air and in water. There have been many studies of different sensing mechanisms including using conductive polymers for detecting gases [2], using a polymer-coated sensing thermopile to detect Enthalpy changes [3]. However, there is little effort in developing integrated signal processing discriminating systems on the same chip. Because the sensor signals in many micro sensors are extremely small, special signal processing circuits are needed to bring the signals out to provide useful information for the users. Increasing the measuring accuracy and decreasing noise is of paramount importance for the on-chip signal-processing unit. In our studies, we investigated two special detection/amplification techniques and built four prototypes. One prototype was delivered and the other three have been demonstrated. The resolution of the relative resistance measurement is better than 10^{-6} . Miniaturization promises to bring hand-held chemical agent sensors into many critical application fields. CMOS-technology offers the possibility to pack the sensor active part and signal processing electronics on one single chip. With the fast pace of the CMOS technology development, miniaturization for many elaborated systems will be possible. Suggestions have been made for future on-chip signal processing developments.

2. Basic Test Principles

(1) DC or AC Wheatstone Bridge method

Because characteristic changes of the polymer upon exposure to an analyte resulting in the resistance changes of the polymer film, this enables a direct low-power electrical signal readout to be used as the sensing signal. The resistance change is the resistance deviation δR . To measure the relative resistance deviation $\delta R/R$ of the polymer film before, during, and after exposure to various analytes, the well known DC or AC Wheatstone Bridge method is the most precise and the easiest way. By using the Wheatstone bridge a sensitive resistive transducer can be made. The basic principle of the Wheatstone Bridge method is shown in Fig. 1.

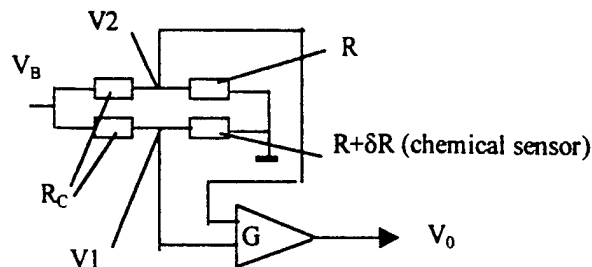

Fig. 1 Schematic of Wheatstone Bridge

The basic equations for calculation:

$$V_0 = G(V_2 - V_1) = GV_B \frac{\frac{R_c}{R} \frac{\delta R}{R}}{\left(\frac{R_c}{R} + 1\right)\left(\frac{R_c}{R} + 1 + \frac{\delta R}{R}\right)}$$

$$\frac{\delta R}{R} = \frac{-V_0(\alpha + 1)^2}{GV_B\alpha - E_0(\alpha + 1)}, \quad \alpha = \frac{R_c}{R}$$

V_B is the voltage of the source which can be DC voltage source or AC voltage source.

(2) AC Quasi-balanced Bridge method[4]

In addition to resistance changes, the absorption of analyte molecules into the chemically sensitive polymer layer (film) may lead to changes in its relative dielectric constant. This results in both resistance and capacitance changes or impedance change. By measuring the impedance changes, these will add new dimension in discriminating different analytes. The AC Quasi-balanced Bridge is an impedance measurement method. Using this method the resistance and capacitance of the test sensor can be analyzed. There are many different methods and techniques for measuring the impedance, such as the null (balance) type bridge which requires adjustments to measure the impedance, and the meter method which measures voltage and the current. Meters are faster and easier to use, but the bridge method is more accurate and has far more dynamic range. In this project we take advantage of the lock-in amplifier. An AC Quasi-balanced Bridge method is used. The basic principle of the AC Quasi-balance Bridge method is shown in Fig.2.

The Bridge consists of a resistance potentiometer R_p (a Sliding resistive Wire), an unknown Z (chemical sensor), and a known standard resistance R_{st} . The individual bridge elements are then Z , R_s , $(1-x)R_p$, and xR_p . A sinusoidal voltage V_s with required frequency, ω , is applied to the bridge. V_d the potential difference between the point of the potentiometer and the node formed by the resistance R_s and the impedance Z , is taken as the output of the sensor.

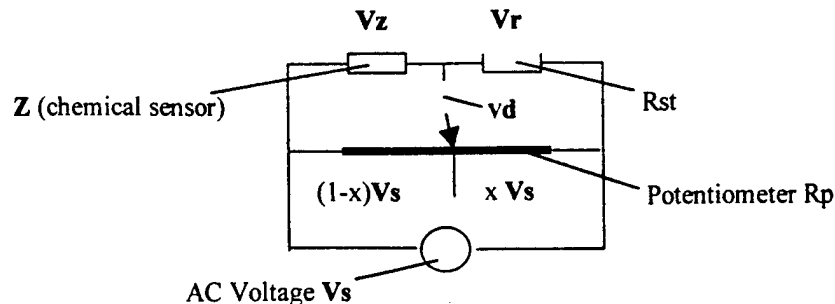

Fig.2 Schematic of the AC Quasi-balanced Bridge method

The two Quasi-balanced points are obtained on the bridge by varying the center position of the potentiometer. If the impedance to be measured is capacitive, the balance conditions are that the voltage V_d is in quadrature ($\phi=90^\circ$) with the source voltage V_s and in quadrature with V_z , the voltage across impedance Z . The phase-sensitive detector (PSD) will indicate zero, when V_d is in quadrature with V_z and in quadrature with V_s . For the first quasi-balanced point, let the setting of the potentiometer x be m (i.e., V_d and V_z are in quadrature) and for the second, be n (i.e., V_d and V_s are in quadrature). When $x=n$. Let $Z=Rs+jXs=Rs+1/j\omega Cs$ in the series-equivalent representation of the impedance. R_s and X_s can be calculated by the following equations.

$$R_s = R_{st} \frac{m(1-n)(1-m)}{(1-n)m^2 + n - m}$$

$$X_s = -\frac{\sqrt{\frac{n-m}{1-n}}(1-n)(1-m)}{(1-n)m^2 + n - m}$$

If the impedance to be measured is a pure resistor R , the present scheme (shown in Fig.2) becomes a simple Wheatstone bridge with AC excitation. When the bridge is balance the V_d is reduced to zero. At this point $x=m=n$ and

$$R = R_{st} \frac{1-m}{m}$$

3. Detection/Amplification on-chip

Because the signal to noise ratio of the low-level signal produced by the resistance bridge circuit or the impedance bridge circuit is small, the on-chip signal processing with signal amplification is the core technique in our studies. We introduced two special detection/amplification methods.

(1) On-chip low-noise differential instrumentation amplifier[5]

To measure relative resistance deviation, we must convert $\delta R/R$ to voltage V_0 . The instrumentation amplifier (IA) is an on-chip differential amplification device with very high input impedance, shown in Fig.3. The signals of the resistance bridge were amplified by the differential amplifier while the common-mode disturbance was canceled. Thus the difference amplifier provides the ability to reject common-mode signal components (such as noise or undesired DC offsets) while amplifying the differential-mode components. We use the two op-amp buffers to provide impedance isolation between bridge transducers, while to increase the input impedance of the differential amp.

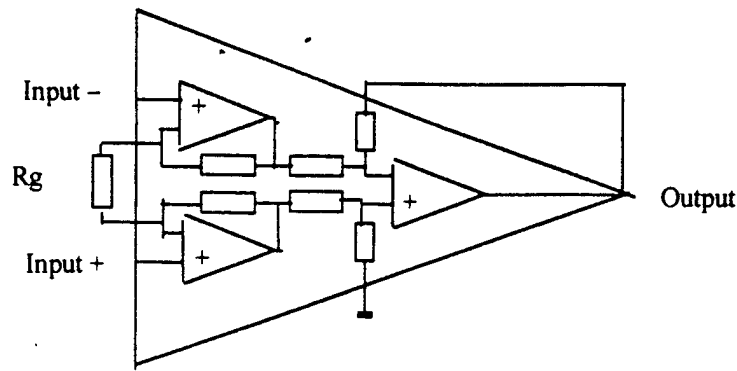

Fig. 3 Block diagram representation of IA.

(2) On-chip Difference Amplifier and Lock-in Amplifier[6]

The combination of the difference amplifier and lock-in amplifier is suitable for conversion of $\delta R/R$ to voltage V_0 in the AC bridge, shown in Fig.4.

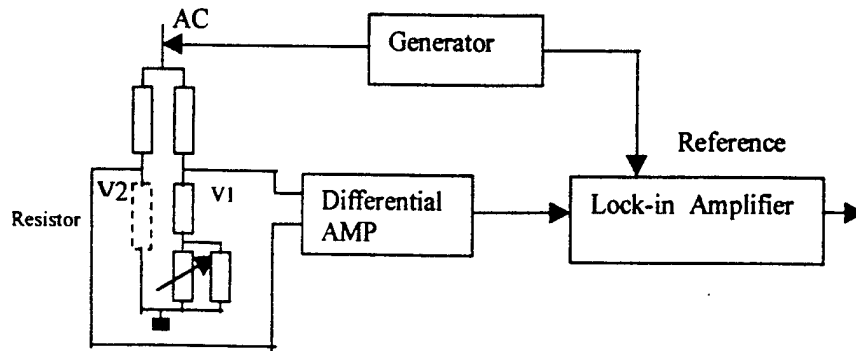

Fig. 4 AC bridge with difference amplifier and lock-in amplifier

The low-level signals amplified by differential amplifier will still have the low frequency noise components, such as temperature-dependent drift. Lock-in amplifiers are able to measure signals accompanied by relatively high levels of noise and interference. The principle of the lock-in amplifier is shown in Fig. 5.

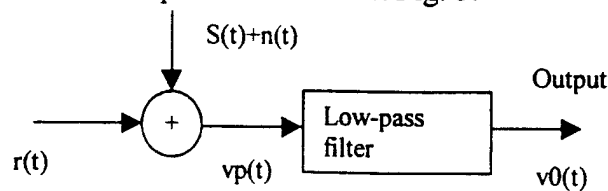

Fig.5 Lock-in amplifier with synchronous phase sensitive detected.

$$v_p(t) = r(t)[s(t) + n(t)]$$

where $s(t)$ is the signal to be measured, $r(t)$, reference signal, and $n(t)$ represents the entire disturbance due to additive noise and interference.

Assume:

$$s(t) = \sqrt{2}V_S \cos[\omega_S t + \phi_S]$$

$$r(t) = \sqrt{2}V_R \cos[\omega_R t + \phi_R]$$

$$V_P(t) = V_S V_R \cos[(\omega_S + \omega_R)t + \phi_S + \phi_R] + V_S V_R \cos[(\omega_S - \omega_R)t + \phi_S - \phi_R]$$

If $\omega_S = \omega_R$, $\phi = \phi_S - \phi_R$, the output of the low-pass filter is the phase sensitive response in a form of DC:

$$V_O = KV_S V_R \cos[\phi]$$

It is clearly that the asynchronous signals such as noise and interference components give rise to an alternating response in the form of "beat" frequency product. The rejection of a large part of the background noise spectrum is inherent in the operation of a synchronous detector and that the frequency selectivity of the detector is governed by the properties of the low-pass filter.

$$\frac{SNR_O}{SNR_I} = \frac{B_I}{B_O}$$

where, B_I is the bandwidth of white noise, and B_O is the bandwidth of the low-pass filter. SNR_O and SNR_I are the signal to noise ratio of output and input, respectively.

For the synchronous type, if v_S and v_R in quadrature ($\phi = 90^\circ$) $V_O = 0$.

4. Construction of Prototypes

For this short-term and low budget project we took advantages of the commercial on-chip amplifiers to build the prototypes.

(1) CST-2 Resistive Chemical Sensor (delivered)

INA114 Precision Instrumentation Amplifier, product of Burr-Brown Inc., is used as the on-chip signal processing. The scheme is shown in Fig.6

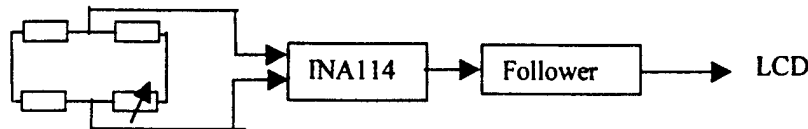

Fig.6 Scheme of CST-2

(2) CSIT-1 Impedance Chemical Sensor

The combination of the difference amplifier OP2227 and the lock-in amplifier AD630 is used as the on-chip detection/amplification unit and as the readout circuit of the potentiometer n and m values. The scheme is in Fig. 7.

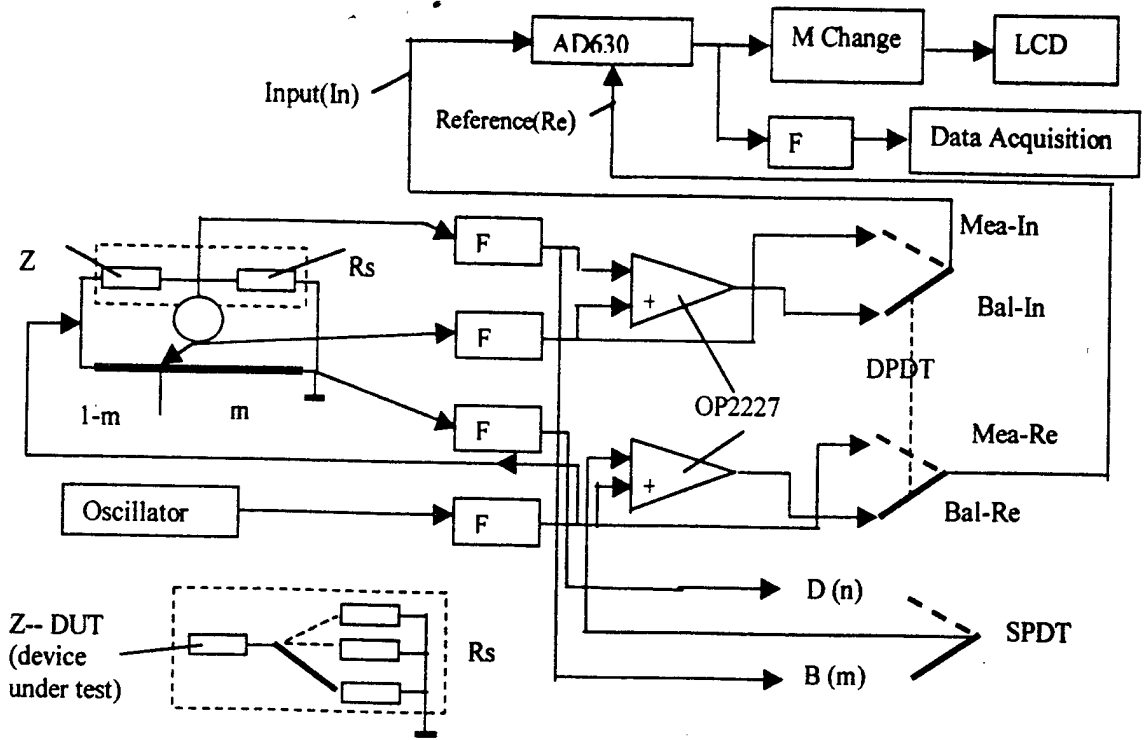

Fig. 7 Scheme of CSIT-1

(3) CST-1 AC Resistive Chemical Sensor

The combination of the difference amplifier OP2227 and the lock-in amplifier AD630 is used as the on-chip detection/amplification unit. The output of the amplifier is input to the Data acquisition board CIO-DAS 1601/12. The tested results can be directly input into Excel program package by download DAS-wizard software. The data analysis and graphic can be performed. The scheme is shown in Fig. 8.

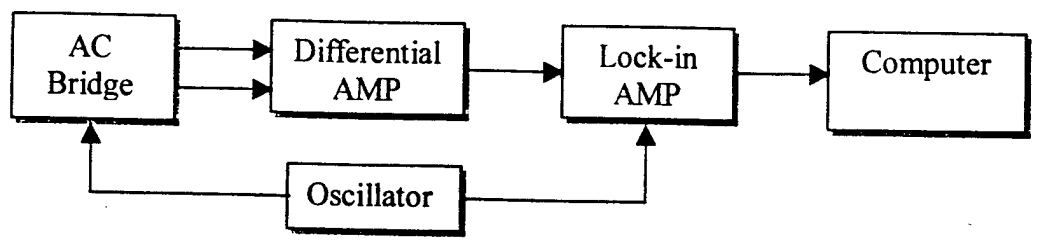

Fig. 8 Scheme of CST-1

(4) Miniature Chemical Sensor Alarm

A minimized prototype with DC bridge is assembled using the single supply ICs as on-chip signal processing unit. The combination of the single supply instrumentation amplifier INA122 & comparator TLC372 is show in Fig. 9. It is in a 2"x 1" box with battery.

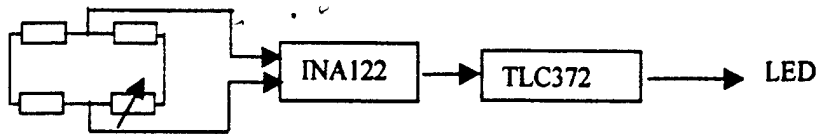

Fig. 9 Scheme of Chemical Sensor Alarm

5. Future work

Three on-chip processing systems for hand-held chemical agent sensors are suggested.

- (1) Chemical agent sensor array with resistance network test system. This system can be developed as an “electronic nose” or “electronic tongue”.
- (2) Embedded Micro-controller controlled chemical agent sensor system.
- (3) Wireless chemical agent sensor system.

References

- [1] J. De Gaspari 2000 *Mechanical Engineering*(January), 57-59, User-friendly sensors.
- [2] M.S.Freund and H.S. Lewis 1995 Proceedings of National Academy of Science of USA 92 2652-2656. A chemically diverse conducting polymer-based “electronic nose”.
- [3] Paper of *Proceedings of SPIE* #3857
- [4] M.A. Atmanand, V.Jagadeesh Kumar, and Vempati G K. Murti, *IEEE Transactions on Instrumentation and measurement*, A microcontroller-Based Quasi-Balanced Bridge for the Measurement of L,C and R, Vol.45,No.3 June 1996
- [5] Rizzoni, Principles and applications of electrical engineering, 1993
- [6] Meade, Lock-in amplifiers: Principles and applications, 1983