

**Naval Air Warfare Center Weapons Division
Radio Frequency Science and Technology Network
Report for Fiscal Year 1999**

by
P. L. Overfelt
Research Department

S. R. Kujiraoka
Weapons Instrumentation Division

and

W. E. Katzenstein
Information Warfare Systems Division

SEPTEMBER 2000

Approved for public release; distribution is unlimited.

NAVAL AIR WARFARE CENTER WEAPONS DIVISION
China Lake, CA 93555-6100

DEFO QUALITY ASSURANCE

DATA QUALITY ASSURANCE

20001030 048

FOREWORD

This report documents the activities of the Naval Air Warfare Center Weapons Division's Radio Frequency Science and Technology Network during fiscal year 1999. This work was funded by NAWCWD Discretionary Core Science and Technology funding.

This report was reviewed for technical accuracy by Sam Ghaleb (Code 473200D).

DR. JOHN FISCHER
Research Department
29 August 2000

REPORT DOCUMENTATION PAGE

Form Approved
OMB No. 0704-0188

Public reporting burden for this collection of information is estimated to average 1 hour per response, including the time for reviewing instructions, searching existing data sources, gathering and maintaining the data needed, and completing and reviewing the collection of information. Send comments regarding this burden estimate or any other aspect of this collection of information, including suggestions for reducing this burden, to Washington Headquarters Services, Directorate for Information Operations and Reports, 1215 Jefferson Davis Highway, Suite 1204, Arlington, VA 22202-4302, and to the Office of Management and Budget, Paperwork Reduction Project (0704-0188), Washington, DC 20503.

1. AGENCY USE ONLY <i>(Leave blank)</i>		2. REPORT DATE <p style="text-align: center;">September 2000</p>	3. REPORT TYPE AND DATES COVERED <p style="text-align: center;">Summary; fiscal year 1999</p>	
4. TITLE AND SUBTITLE Naval Air Warfare Center Weapons Division Radio Frequency Science and Technology Network Report for Fiscal Year 1999			5. FUNDING NUMBERS	
6. AUTHOR(S) P. L. Overfelt, S. R. Kujiraoka, W. E. Katzenstein				
7. PERFORMING ORGANIZATION NAME(S) AND ADDRESS(ES) Naval Air Warfare Center Weapons Division China Lake, CA 93555-6100			8. PERFORMING ORGANIZATION REPORT NUMBER <p style="text-align: center;">NAWCWD TM 8304</p>	
9. SPONSORING/MONITORING AGENCY NAME(S) AND ADDRESS(ES)			10. SPONSORING/MONITORING AGENCY REPORT NUMBER	
11. SUPPLEMENTARY NOTES				
12a. DISTRIBUTION/AVAILABILITY STATEMENT Approved for public release; distribution is unlimited.			12b. DISTRIBUTION CODE	
13. ABSTRACT <i>(Maximum 200 words)</i> <p>(U) This report documents the activities of the NAWCWD Radio Frequency (RF) Science and Technology (S&T) Network for fiscal year 1999. During fiscal year 1999, the RF Network continued to support the work of individual scientists and engineers via the Core Science and Technology funding provided by the NAWCWD Discretionary program, and continued to provide increased communication among its membership by initiating RF web site development by holding a second retreat. The RF Network continues to be the only NAWCWD network with full participation between the Pt. Mugu and China Lake sites.</p>				
14. SUBJECT TERMS RF S&T Network Radio frequency science and technology network S&T network			15. NUMBER OF PAGES <p style="text-align: center;">66</p>	
			16. PRICE CODE	
17. SECURITY CLASSIFICATION OF REPORT <p style="text-align: center;">UNCLASSIFIED</p>	18. SECURITY CLASSIFICATION OF THIS PAGE <p style="text-align: center;">UNCLASSIFIED</p>	19. SECURITY CLASSIFICATION OF ABSTRACT <p style="text-align: center;">UNCLASSIFIED</p>	20. LIMITATION OF ABSTRACT <p style="text-align: center;">SAR</p>	

CONTENTS

Acknowledgement.....	1
Introduction.....	3
Mission Statement of RF S&T Network.....	3
RF Network Voting Membership.....	4
Summary of FY99 Activities.....	4
Overview of the FY99 RF Core S&T Program.....	5
Downselect Process for FY99 Core S&T Proposals.....	5
Core RF S&T Projects Funded During FY99.....	6
FY99 RF Network Web Site Development.....	7
RF Network Web Site Prototype Template.....	7
RF Network Second Retreat.....	9
RF Network Future Directions.....	10
Summary and Conclusions.....	12
References.....	14
Appendixes:	
A. FY99 RF Net Proposal Total Scores.....	A-1
B. Proposals of FY99 RF Network Core S&T Projects.....	B-1
C. Final Reports for FY99 Core S&T Projects.....	C-1
D. RF S&T Network Retreat Minutes.....	D-1
Distribution.....	E-1

ACKNOWLEDGMENT

The authors wish to thank Mr. Frank Markarian and Dr. Karen Higgins for their continued financial support via NAWCWD Core Science and Technology Discretionary Funding.

This page intentionally left blank.

INTRODUCTION

The Naval Air Warfare Center Weapons Division (NAWCWD) Radio Frequency (RF) Science and Technology (S&T) Network was created at the beginning of fiscal year 1997 (Reference 1) and has been functioning since that time as one of NAWCWD's eight Science and Technology Networks. Its primary mission is to serve the RF portion of the NAWCWD community by promoting communication among RF scientists and engineers (S&Es), providing information and guidance on technical issues related to many diverse types of RF work, and overseeing RF Core Science and Technology (Core S&T) discretionary funding. The RF Network serves approximately 160 members at the Pt. Mugu and China Lake sites and is composed of S&Es from 4.0 (the Research and Engineering Competency) and 5.0 (the Test and Evaluation Competency). The network is administered by a Chair, West Katzenstein (Code 452310D); a Technical Facilitator, Pam Overfelt (Code 4T4100D); and a Pt. Mugu Site Lead, Scott Kujiraoka (Code 543E00E). All decisions are made by a network voting group of approximately 20 members who each represent a particular RF area or functionality.

MISSION STATEMENT OF RF S&T NETWORK

The purpose of the NAWCWD RF S&T Network is to serve the NAWCWD RF community by providing:

- a forum to promote communication
- information on RF activities, technical capabilities, facilities, experience, and knowledge
- guidance in the form of counsel and advisors
- a strategic vision of current and future RF technology opportunities and needed capabilities
- recommendations to sponsors to support development of needed RF technology at NAWCWD

so that the RF community can:

- benefit from the full spread of resources
- maintain a common vision of NAWCWD strengths, weaknesses, opportunities and threats
- cooperate in the marketing, planning, and execution of projects
- develop needed capabilities in a coordinated and focused manner

RF NETWORK VOTING MEMBERSHIP

The RF Network supports an RF constituency of approximately 160 scientists and engineers. A subset of this constituency constitutes the voting membership of the RF Network. The voting membership is determined by the goal of balanced representation across sites and across competencies and by the level of activity demonstrated by members. The voting group is composed of approximately equal numbers of scientists and engineers (S&Es) from the Pt. Mugu and China Lake sites. A majority vote of those present at any given meeting decides on any issue being discussed.

In fiscal year 1999 (FY99) the RF Network voting membership remained the same as in the two previous years. However by the end of FY99 several of the older voting members decided to retire, and several new members were added to the list. However these new members did not become active until FY00 and thus the members responsible for all decisions in FY99 are as shown in Reference 1.

SUMMARY OF FY99 ACTIVITIES

During FY99 the activities of the RF Network fell into the following general categories:

1. **Video teleconferences (VTCs) involving the Pt. Mugu and China Lake sites.** The VTCs had the objectives of technical presentations, communication, and execution of network business in the areas of Core S&T Project management, Web Page Development, and planning.

2. **Management of the RF Core S&T resources.** Principal activities included developing technical guidance, issuing the call for proposals, defining and executing a

downselect process, and providing a mid-year review of progress made by the principal investigators.

3. **Development of an RF Web Site.** During the year it became clear that a RF Web Site would provide significant support to the RF community and that it would be necessary to dedicate appropriate resources to its development and maintenance.

4. **Network Retreat.** The main objectives were to establish future directions for the Network and to plan for the FY00 effort.

5. **Communication of RF Network activities.** This included a mid-year review to center management and a report documenting network activities during FY99.

More detail on these activities is provided in the following sections of this report.

OVERVIEW OF THE FY99 RF CORE S&T PROGRAM

DOWNSELECT PROCESS FOR FY99 CORE S&T PROPOSALS

This is a summary of the RF Network process used to choose Core S&T proposals for FY99.

In the last quarter of FY98, the RF Network sent out a call for Core S&T proposals and received many more proposals than it could possibly fund. All proposals were sent out to the voting group so that everyone could read them before the discussion meeting. A meeting was held where all proposals were discussed and downselected until 11 proposals were obtained that the members felt deserved to be voted on. Proposals were immediately discarded if (1) they were not Core S&T in nature; (2) they were not specifically RF in nature; (3) much more work was proposed than could possibly be accomplished with \$20,000 to \$25,000; or (4) they clearly belonged under another Network.

A second meeting was held where the 11 remaining proposals were discussed. A scoring sheet was made up and distributed to the voting group, with each proposal allowed a total of 20 points maximum: 10 for technical merit/originality and 10 for transition potential to external funding. The summarized final scores of the 11 proposals are contained in Appendix A. The first column is the shortened proposal name, the second column is the Principal Investigator, the next 12 columns are the 12 evaluators' scores, and the last column contains the final averaged score for each proposal. Voting

members were encouraged to abstain if they were unfamiliar with the material covered by a given proposal. If any of the voting members were themselves Principal Investigators of a proposal, they naturally abstained from voting on their own proposals.

The RF Network Chair, West Katzenstein, a selected voting group member, and the RF Network Technical Facilitator, Pam Overfelt, totaled up the scores, averaged them, and then chose the five proposals with the highest scores and let everyone know the results. All specific evaluators and their evaluations remained confidential except for the Chair and the Facilitator; however the numbers from the evaluations were made available to anyone who wanted access. Because the RF Network believes that feedback is extremely important, all the comments that were made on the individual proposals by the members of the voting group were sent back to each PI separately.

FY99 was the first year that the RF Network received many more proposals than it could fund, and thus it was the first year that the Network needed to have a documented selection process to ensure fairness. After talking with those scientists and engineers who participated in this process, the most important factors seemed to be that the process was set ahead of time, it was publicized in detail, and it was carried out as promised.

CORE RF S&T PROJECTS FUNDED DURING FY99

In FY99 the RF Network received (after a \$10,000 cut at the midyear accounting) a total of \$110,000 of discretionary funding. Out of this amount, the RF Network funded five Core S&T projects at \$20,000 each and kept \$10,000 for network administration.

The five Core S&T projects funded by the RF Network in FY99 were:

- Infrared Transparent, Electrically Conductive Coatings for RFI/EMI Mitigation and Reduced Radar Cross Section on Aircraft Sensor Windows, Canopies, and Missile Domes, by Linda Johnson and Mark Moran (References 2 through 4)
- Fractal Antennas for Multiband/Broadband Use, by Pam Overfelt (References 5 and 6)
- Radiation from Antennas Flush-Mounted on Photonic Band Gap Structures, by Merle Elson (Reference 7)
- Surface Wave (Wire/Laser) Induced RF Path, by Dan Garcia and Ron Skatvold
- Low Noise Exciter for Millimeterwave Seekers, by Curt Kidner

Four of these projects were worked on by the respective Principal Investigators throughout FY99. It was determined that Kidner's Low Noise Exciter for Millimeterwave Seekers project could not be carried out with the amount of money available and that performing the experiment with a substitution of much less expensive material instead of the original material needed would not provide adequate information. Thus this funding was returned back to the RF Network.

The original proposals for each project are contained in Appendix B. The final reports detailing each project's progress and accomplishments are contained in Appendix C. The Surface Wave (Wire/Laser Induced) RF Path project by Ron Skatvold and Dan Garcia did not send in a final report.

FY99 RF NETWORK WEB SITE DEVELOPMENT

At the RF S&T Retreat and at several VTC meetings, the topic of how to inform the RF community about the RF capabilities at NAWCWD was discussed. It was determined that the best approach to accomplish this goal was to create a RF Web Page. At this site, sponsors could research the NAWCWD resources (both personnel and facilities) available to them. Other RF engineers and scientists could also use it to gather information on the latest technological advances in their respective fields. The active members of the RF S&T Network could use it to become informed on the latest activities sponsored by the Network. It was decided to direct specific funding to web site development, to be a funded priority during FY00. Below are the FY99 accomplishments made toward setting up this Web Page.

RF NETWORK WEB SITE PROTOTYPE TEMPLATE

Piotr Adamski (Code 454510E) completed the prototype RF Network web site template and installed it temporarily on a private server. Initial verification of the site layout by the RF Network members has been accomplished via this address. The template included the Masthead graphic, the RF Network logo, and a prototype menu system. Status is described below.

Masthead Graphic

Masthead graphic design has been completed and shown to all active RF Network members. No comments were made concerning modifications, so it will be the official masthead graphic of the NAWCWD RF Network organization.

RF Network Logo

The official logo design has been completed and shown to all active RF Network members. The logo was approved and is now the official logo of the RF Network organization. Figure 1 presents the logo.

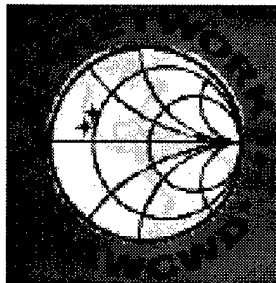

FIGURE 1. RF S&T Network Logo.

Prototype Menu System

The prototype web site design has been presented with fully functional menu selection that allows the user to view the layout of each page template. The menu, along with a brief description of each selection, is shown below:

1. News - Mission Statement, minutes from the monthly VTC meetings, call for proposals, and any news relating to RF technology
2. Database - Database of NAWCWD personnel (Who's Who)
3. Test Facilities and Capabilities - Database of the RF test facilities and capabilities at NAWCWD
4. Marketing Assistance - Listing of technical thrusts, potential sponsors

5. Technical Proposals - Current RF Network submitted proposals as well as past RF Network funded proposals
6. Current Opportunities - Available training, symposia, and conferences, along with upcoming meetings
7. Technical Reports - Technical reports related to RF technology
8. Related Web Links - Collection of useful web sites (vendors, antenna research)

Permanent Web Site Navy Security Approval Process

Piotr Adamski applied for web site approval on a NAWCWD secured server, and the final approval was given in mid November 1999.

Software Development Tools Acquisition

The Dreamweaver Studio 99 software has been purchased. This software was used to create the current web site template, and it will be used for further development efforts. In addition, several books helpful in database design processes have been purchased.

RF NETWORK SECOND RETREAT

The RF S&T Network had its original Retreat on 19 May 1997 at the Pt. Mugu site. At that time, the Mission Statement and Strategic Business Vision (SBV) for RF Technology at NAWCWD were formed. A second all-day Retreat was conducted on 28 September 1999 at the China Lake site to refocus the SBV of the Network as well as to mature our relationships as a team. A long-term goal for the SBV is to guide the Network toward support of RF activities at NAWCWD. With this SBV in place, the network can provide guidance to the community in support of the preparation of solicited proposals that promote advanced RF technology.

Since the Network was founded three years ago, it seems that most of the funds have gone into the administration and funding of proposals that advanced technology in the RF field. It was mentioned that the Network should also be a place where NAWCWD scientists and engineers can interact to exchange ideas.

Below is the list of topics covered during the Retreat:

1. Reiterate (Core) S&T Definition
2. Future Directions
 - a. Monthly VTC meetings
 - b. Development of the RF Web Page
 - c. Facilities tours
 - d. Create and maintain a calendar of RF S&T Network events
 - e. Establishment of technical seminars
 - f. Future Retreats
3. Proposals
 - a. Down-select process
 - b. Trade-off between project size and number of projects to be funded
 - c. Expand Pt. Mugu participation
4. FY00 Funding
5. Open Forum

A detailed account of the Retreat is contained in Appendix D. Future directions for the RF Network are discussed below.

RF NETWORK FUTURE DIRECTIONS

Based on its overall objective of supporting the RF community, in FY99 the RF Network continued to place significant priority on defining and refining its future role. This was particularly evident in the focused list of retreat topics that the voting members developed in preparation for the retreat, in the high level of participation and energy that was realized at the retreat, and in the constructive plans and recommendations that were generated at the retreat.

The key recommendations for future directions resulting from the retreat are summarized below.

1. **Place renewed focus on networking.** This key function of the network was somewhat diminished during FY99 due to funding cuts. In order to compensate for

funding cuts, resources were directed away from networking and in favor of protecting the Core S&T projects. The following specific recommendations were developed:

- a. Increase the priority of developing the RF Web Page and ensure that it is adequately funded. In the past web page development was expected to occur using a large component of volunteer labor. This is not realistic.
- b. Hold regularly scheduled monthly VTCs.
- c. Host tours between sites as a funded network activity.

2. **Increase the level of technical exchange.** Technical exchange was also diminished during FY99, due to funding cuts. The following specific recommendations were developed:

- a. Schedule regular technical seminars at the monthly VTCs.
- b. Build and maintain a calendar of current events to go on the RF Web Page.
- c. Post technical presentations on the Web Page.
- d. Post video displays of facility tours on the Web Page.

3. **Improve the process for selecting Core S&T proposals.** Members were generally pleased with the process used in FY99 but concerned that it did not achieve balance between the two sites. An improved process was developed that supports the cultures and business bases of both sites. In this process, all proposals are first screened for appropriateness for RF Core S&T funding and to be sure that they fall within the announced funding guidelines. All proposals are then evaluated by all voting members, using a predetermined rating process. The China Lake proposal ranked highest by China Lake voting members is chosen to be funded. Likewise, the Pt. Mugu proposal ranked highest by Pt. Mugu voting members is chosen to be funded. This guarantees that at least one proposal at each site chosen by voting members of that site will be funded. The remaining proposals from both sites are ranked as one lot, based on each proposal's being evaluated by all voting members, as described above. Proposals are funded in order of their ranking at the pre-determined level of funding, until the total funding available is committed.

SUMMARY AND CONCLUSIONS

During FY99 the RF Network focused its efforts in a number of areas, with the major thrust of managing the Core S&T projects. As resources were reduced by center management, it was decided to take money away from Network administration in order to leave the project funding intact. This was carried out but not without a price. The network held fewer meetings in FY99, had fewer presentations, and in general sacrificed its communications and networking functions in favor of funding Core S&T projects.

During FY99, the Network achieved complete parity between the Pt. Mugu and China Lake sites, with approximately equal numbers of S&Es from both sites participating in the voting group. The lead for the Pt. Mugu Site passed to Scott Kujiraoka upon the retirement of Harry Franz (the former lead).

Throughout the year, the Network acted as a clearinghouse for requests concerning information on RF from those needing technical support, and it also brought together RF engineers and scientists in need of funding with those who had work to offer.

The Network began the process of creating an official web site. Activities from previous years were documented in a Technical Memorandum (Reference 1).

A number of recommendations for future directions were developed at a retreat hosted late in FY99. These included specific steps to create a renewed focus on networking, activities to increase the level of technical exchange, and an improved process for funding Core S&T proposals that will better reflect the cultures and business bases of both sites.

A number of payoffs continue to result from the activities of the RF Network:

1. **Participation at both sites.** The RF Network has a total constituency of about 160 scientists and engineers.
2. **Core S&T projects provide needed capabilities with high transition rates.** These projects capitalize on a "bottom-up" response to thrusts and guidance from the Network and are chosen using a peer selection process.
3. **The RF Network nurtures communication and trust within the RF community.**

4. **The RF Network provides a corporate point of contact for RF support.** The Network has linked customers with RF experts and has linked under-funded engineers with customers.

5. **RF scientists and engineers can interact with customers from a corporate view.** The Network helps make S&Es aware of NAWCWD RF people capabilities and RF facilities.

6. **NAWCWD has greater strength in its relationships with other organizations.**

It is strongly recommended that the level of funding for the RF S&T Network be increased to support a better mix and level of networking and Core S&T activities.

REFERENCES

1. Naval Air Warfare Center Weapons Division. *Activities of the Naval Air Warfare Center Weapons Division Radio Frequency Science and Technology Network During Fiscal Years 1997 – 1998*, by P. L. Overfelt, W. E. Katzenstein, and S. R. Kujiraoka. China Lake, CA, NAWCWD, November 1998. (NAWCWD TM 8185, publication UNCLASSIFIED.)
2. M. B. Moran and L. F. Johnson. "Carbon-Nitride, Diamond-Like-Carbon and Silicon-Based Films Synthesized by Electron Cyclotron Resonance Chemical Vapor Deposition," *Mat. Res. Soc. Symp. Proc., Properties and Processing of Vapor-Deposited Coatings*, Boston, MA, 30 November - 4 December 1998. (Invited paper, paper and proceedings UNCLASSIFIED.)
3. L. F. Johnson and M. B. Moran. "P-Type CuAlO_2 and Other IR-Transparent, Electrically-Conductive Coatings Deposited by Magnetron Sputtering," *Mat. Res. Soc. Symp. Proc., IR Semiconductor Materials and Devices*, Boston, MA, 30 November - 4 December 1998. (Paper and proceedings UNCLASSIFIED.)
4. M. B. Moran and L. F. Johnson. "Silicon-Carbon Alloys Synthesized by Electron Cyclotron Resonance Chemical Vapor Deposition," *Proc. SVC*, Chicago, IL, 19-22 April 1999. (Paper and proceedings UNCLASSIFIED.)
5. P. L. Overfelt. "Analytic Series Solutions for Decomposition of the Dipole Field Into Homogeneous and Evanescent Parts," *Phys. Rev. E* (submitted 1999).
6. Naval Air Warfare Center Weapons Division. "Two Approaches to Single Element Fractal Antenna Analysis," by P. L. Overfelt. China Lake, CA, NAWCWD, October 1999. (NAWCWD memo 3900, 4T4120D/001; White Paper submitted to the Office of Naval Research; paper UNCLASSIFIED.)
7. J. M. Elson. "Calculation of Radiation From a Long Antenna Situated on a Photonic Crystal Substrate," *IEEE Trans. on Antennas Propag.* (submitted 1999).

Appendix A

FY99 RF NET PROPOSAL TOTAL SCORES

This page intentionally left blank.

FY99 RF Net Proposal Total Scores

Proposal	Investigator	Eval 1	Eval 2	Eval 3	Eval 4	Eval 5	Eval 6	Eval 7	Eval 8	Eval 9	Eval 10	Eval 11	Eval 12	Final Score (Avg)
Crossover	Sailor	5	9	3	8	16	15	14	8	8	17	8	14	10.417
Isolation	Wang	13	15	2	10	18	2	10	6	17	13	13	17	11.333
RF Path	Skatvoid	18	14	1	8	16	3	9	13	15	20	A	A	11.700
Pol. Div.	Ryken	15	12	0	7	A	A	12	4	15	15	9	16	10.500
Frac. Ant.	Overfelt	18	12	11	18	19	5	15	A	15	18	20	19	15.454
PBG Ant.	Eison	18	14	2	A	A	8	18	15	17	16	12	15	13.500
IF Harmonic	Schiavone	5	15	0	10	15	1	10	2	9	13	15	A	8.636
Frac. Arrays	Tran	15	14	1	14	A	0	15	10	12	13	15	14	11.182
Pol. Comp.	Roush	10	15	2	8	15	1	13	7	14	16	5	15	10.083
IR Coatings	Johnson	20	16	15	20	19	8	17	17	18	15	18	20	16.917
Low Noise	Kidner	18	16	6	15	A	10	16	14	14	13	12	A	12.182

A= abstain

The final score was averaged by dividing by the number of people who voted on a given proposal. The maximum score from an individual evaluator was 20 points; 10 for originality/technical merit and 10 for transition potential.

For FY99 the RF Net can fund 5 projects at \$20,000 per project.

The results for proposals submitted to the RF Net for FY99 are shown above. The top 5 are:

- (1) Infrared Transparent, Electrically Conductive Coatings for RF/EMI Mitigation and Reduced Radar Cross Section on Aircraft Sensor Windows, Canopies and Missile Domes - Johnson/Moran
- (2) Fractal Antennas for Multiband/Broadband Use - Overfelt/Leese
- (3) Radiation From Antennas Flush-Mounted on Photonic Band Gap Structures - Eison
- (4) Low Noise Exciter for mmW Seekers - Kidner/Afendykiw
- (5) Surface Wave (Wire/Laser Induced) RF Path - Skatvoid/Garcia

This page intentionally left blank.

Appendix B

PROPOSALS OF FY99 RF NETWORK CORE S&T PROJECTS

(The reports contained in this appendix are reproduced in facsimile.)

This page intentionally left blank.

PROJECT 1
RF NETWORK CORE S&T PROPOSAL

Project Title: Infrared Transparent, Electrically Conductive Coatings for RFI/EMI Mitigation and Reduced Radar Cross Section on Aircraft Sensor Windows, Canopies and Missile Domes

Date: 1 Sep 98 **FY:** 99 **\$K:** \$20K **Continuing Project:** 2nd year

Investigators: Linda Johnson (4B1100D, x1422, 0.15 Manyears),
 Mark Moran (4B1100D, X8942, 0.10 Manyears)

OBJECTIVE

Develop electrically-conductive, durable coatings for the external surfaces of infrared (IR) sensor windows and missile domes to shield the internal electronics from electromagnetic and radio frequency interference (EMI/RFI) and to reduce the radar cross section (RCS). Measure the electrical properties and microwave transmittance of these new thin-film materials to assess their potential use as radar antenna elements, radar-absorbing-material (RAM) backplanes and frequency-selective antenna windows.

BACKGROUND AND NEED

Microwave and radio frequency (RF) electromagnetic interference (EMI) in the 200MHz to 40GHz range can severely degrade the performance of an IR seeker by producing electronic noise in the internal components. Current EMI-shielding solutions for sensor windows and missile domes employ micromesh coatings made from soft metals like gold or copper deposited directly onto the transparency. Off-axis-seeker performance would improve if the grid structure could be eliminated and replaced with a continuous coating of an IR-transparent electrical conductor. However, there are fundamental reasons based on free electron theory why IR transparency and EMI shielding are difficult to obtain with a continuous coating. All of the commonly used transparent conductive oxides (TCOs) like indium tin oxide (ITO) are n-type semiconductors with carrier densities on the order of 10^{20} to 10^{21} cm^{-3} . IR transparency with these n-type semiconductors is not possible because free electron conduction places a reflective plasma resonance at wavelengths longer than about 2 μm . Recently, the first example of a TCO with p-type conduction was demonstrated [Kawazoe, et al. *Nature* **389**, p. 939 (1997).] Kawazoe's group used laser ablation to deposit thin films of CuAlO_2 exhibiting p-type conduction. The existence of a p-type TCO is an important result. The high effective hole

mass of the p-type carriers in CuAlO_2 should shift the plasma frequency to longer wavelengths.

To save weight and volume on airborne radar, there is a need to develop synthetic RAM that can be used in thin-film form and can provide radar absorption over a wide frequency range. Most current RAM are ferrite-based and need to be several centimeters thick to provide adequate absorption. In addition, ferrite-based RAM tend to have narrow frequency response. An Artificial Ferrite RAM (AFRAM) can be designed to provide adequate radar absorption over a broad frequency range. A typical AFRAM is a patterned multilayer structure comprised of alternating thin-film layers of magnetic metal and ferrite materials in which the magnetic film layers are segmented into small platelets. To provide adequate radar absorption, the RAM needs to have large and nearly equal values for the dielectric constant, ϵ , and magnetic permeability, μ . The layered delafossite structure of naturally occurring CuFeO_2 mimics that of a synthetic AFRAM. In addition, CuFeO_2 is highly magnetic and electrically conductive and, therefore, should have excellent broadband radar absorption properties.

PROGRESS

The first demonstration of a p-type TCO for use in the mid- and long-wave IR is a significant accomplishment and dismisses a 20-year-old belief that IR transparency and conductivity cannot be accomplished with a continuous coating. Continuous films of reactively sputtered copper aluminum oxide (CuAl_xO_y) were deposited using a new automated research coating (ARC) system. The copper-rich CuAl_xO_y films are p-type conductors, transmit over 70% at wavelengths as long as 26 μm and have sheet resistance values only 54 times higher than the EMI shielding requirement of 10 Ω/sq . The enhanced electrical conductivity of the CuAl_xO_y film is attributed to the d-orbital bonding between the Cu and Al provided by the stacked delafossite crystalline structure. The IR absorption bands at 1390 and 1450 cm^{-1} are tentatively assigned to Cu-Al stretching modes involving d-orbital bonds. It is difficult to control the composition of the CuAl_xO_y films because they are deposited by co-sputtering in a reactive-oxygen-argon gas from high-purity-Al and -Cu targets that gradually oxidize and change sputter rate during the coating run. Surface analysis of the films confirmed that the Al-sputter rate decreases more rapidly than the Cu-sputter rate as the targets oxidize. To overcome this fabrication issue, hot-pressed CuAlO_2 targets are being developed by Sienna Technologies, Inc. under a Phase I Small Business Innovative Research (SBIR) contract. Seven hot-pressed targets of varying chemical composition have been delivered. Films deposited in the ARC system from the CuAlO_2 targets so far have been Al_2O_3 -rich and are very resistive. The composition of the latest CuAlO_2 target appears to be closer to stoichiometric. Transparent, conductive films may soon be achieved by doping with a small amount of metal from a second pure metal target like platinum or palladium. Conductive films have

been deposited by sputtering from a magnesium-doped CuAlO_2 target but the films are not transparent. Finally, Sienna has successfully fabricated the CuFeO_2 powders and a small hot-pressed target (1cm x 1cm x 1.5mm). Preliminary data shows that the CuFeO_2 is electrically conductive, magnetic and very hard. Efforts to fabricate a 2-inch-diameter target for the ARC are continuing. The radar absorption properties of the small CuFeO_2 target will soon be determined using a microwave spectrometer at the University of Washington (UW). The microwave spectrometer at UW will be very useful for determining the radar absorption spectrum for all of the targets and films fabricated in this project.

Work on the metal borides continues. Adding a third metal to TiB_2 leads to a good trade of conductivity for transparency. TiB_x films have resistivities of less than 0.0002-cm and could replace softer gold in mesh designs.

POTENTIAL BUSINESS THRUSTS

New RAM for UCAV reconnaissance radar, Signature Control, Precision Strike

This page intentionally left blank.

PROJECT 2
DISCRETIONARY FUNDS REQUEST FORM

Circle One: B&P MSI Core S&T IR Dept. Priority #

Project Title: Fractal Antennas for Multiband/Broadband Use

Principal Investigators: P. L. Overfelt

FY: 99 \$K: 30

<u>Code</u>	<u>Ext.</u>	<u>Bldg/Room</u>	<u>Dept. FMA</u>	<u>Workyears (1750 Hrs)</u>
4B1000D	9-3958	SSL/S50	D. Cody	0.30

OBJECTIVE

To investigate wire/aperture antennas composed of fractal geometries and determine whether or not fractal geometries can produce electrically small antennas of high efficiency and broad bandwidth; also to determine whether or not certain shrunken single-element fractal antennas have higher gain than their Euclidean full-sized counterparts.

NEED AND BACKGROUND

Fractal geometry is an extension of Euclidean geometry. In fractal geometry a complex structure is built up through the repetition of a specific design (often called a generator) on a series of different size scales. Thus it becomes possible to describe a variety of self-similar objects which possess structure at all scales. An emerging area of research, fractal electrodynamics, involves combining fractal geometries with Maxwell's equations as a means of solving a new class of propagation, radiation, and scattering problems. The application of concepts from fractal geometry to describe self-similar radiating structures is of interest. These self-similar radiating structures are called *fractal antennas* [1-4].

Under many circumstances (for example frequency hopping) it would be advantageous to have an antenna that resonates not at just one frequency but at a number of different frequencies which are not necessarily harmonics of the lowest frequency [1,5]. It has been shown experimentally (although there is no coherent fractal electrodynamic theory to explain these results) that (1) wire, slot, and other types of antennas shaped like multi-iteration fractals resonate; (2) a class of the above can radiate; (3) certain fractals can shrink the size of an antenna [1]. Two outstanding characteristics of fractal antennas that have emerged from experimental work are: (A) When shaped into

islands, fractals *do not* experience significant drops in radiation resistance for their size (area) as do Euclidean shapes. (B) The perimeters of the fractals do not correspond to the lengths expected from the measured resonant frequencies. Instead the lengths are always longer [1,2]. Thus some effective velocity change of the wave caused by the fractal nature of the antenna seems to occur. This is not an effect which is a property of geometric fractals - it is an effect which is a property of fractals only when they are considered as radiators [6].

It is also of great interest to have broadband antennas for multi-function aperture applications. Multi-iteration fractal antennas have the possibility of achieving resonances that fall within a few percent of one another producing "resonance clusters". Resonance clusters extend down into the frequency regime where the antenna is electrically small yet this approach requires no matching network. Resonances become clustered closer together and lower in frequency as the number of fractal iterations increases making higher iteration fractals more attractive for broadband electrically small performance. Provided the radiation resistance of the resonances in a cluster is similar, the effect is that of a continuous series of resonances which resemble a single resonance of broad bandwidth. This is a completely new way to obtain broadband antennas.

APPROACH

Because of both numerical and experimental results on the Sierpinski gasket antenna [5], i.e., the fact that its frequency bands are log-periodically spaced by a factor of two (the same scale factor relating self-similar structures on the fractal shape itself), it has been concluded that the self-similarity properties of the fractal structure can be translated to its electromagnetic behavior. Thus we wish to consider analytical/numerical means of solving Maxwell's equations on fractal boundaries which radiate and allow prediction of the radiator's resonance frequencies, radiation pattern, bandwidth (if clusters are present), gain, and other electromagnetic behaviors.

EXPECTED RESULTS

We expect to provide a definitive answer to whether or not efficient electrically small broadband antennas with reasonable gain can be achieved using multi-iteration fractal geometries as radiators.

EXTERNAL RELATIONSHIPS

This work is directly applicable to the ongoing ONR effort on multi-function RF apertures, AMRFS. It is also applicable to two of the NAWCWD major thrust areas, (1) Integration with the 21st Century Battlespace (C4ISR), and (2) Uninhabited Combat Aerial Vehicles (UAV/UCAV) in the area of secure communications, including secure sensors, secure data links, and antijam capability. The above effort is a fundamental research effort that could be the beginning phase of a potentially integrated program including exploratory and advanced development. This is a new and emerging technology that has not been adequately studied by other government or private sector laboratories.

REFERENCES

1. N. Cohen, "Fractal Antennas: Part 1", *Communications Quarterly*, pp. 7-22, Summer (1995).
2. N. Cohen, "Fractal Antennas: Part 2", *Communications Quarterly*, pp. 53-66, Summer (1996).
3. N. Cohen and R. Hohlfield, "Fractal Loops and the Small Loop Approximation", *Communications Quarterly*, pp. 77-81, Winter (1996).
4. D. H. Werner and P.L. Werner, "Frequency independent features of self-similar fractal antennas", *Radio Science*, 31, 1331-1343 (1996).
5. C. Puente-Baliarda, et al, "On the behavior of the Sierpinski gasket multiband fractal antenna", *IEEE Trans. Antennas Propagat.*, AP-46, 517-524, April (1998).
6. M.V. Berry, "Diffractionals", *J. Phys. A*, 12, 781-797 (1979).

This page intentionally left blank.

**PROJECT 3
DISCRETIONARY FUNDS REQUEST FORM**

Circle one: B&P MSI CORE S&T Date: August 1998

Project Title: Radiation From Antennas Flush-Mounted on Photonic Band Gap Structures

Principal Investigator: J. Merle Elson Funding Requested FY-99: \$20K
Code 4B4000D Ext: 939-1429 Bldg/Room: ML/1419 Dept. FMA D Cody

OBJECTIVE

To develop a theory which can be used to predict the radiation pattern of an antenna which is flush-mounted on a photonic band gap (PBG) structure consisting of lossless dielectric material. The frequency of operation shall be within the band gap and consequently, the PBG is 100% reflective. Of particular interest is the possibility of coupling into surface wave modes supported by the PBG structure.

NEED AND BACKGROUND

A need for flush mounted antennas exists because of stealth and aerodynamic requirements. However, from the communication standpoint, such requirements can impose inefficient and incompatible compromises when engineering and designing antennas. An antenna or antenna array mounted on a dielectric substrate tends to radiate most of the transmitted energy into the dielectric and a metallic reflector is very absorbing. A properly designed photonic crystal array, constructed of lossless dielectric material, can function for EM waves like an electronic crystal can function for electrons: i.e., a frequency band gap can exist. This means that an antenna operating at a frequency within the band gap cannot radiate into the PBG structure. The periodicity of the PBG structure is on the order of a wavelength and fabrication is feasible for use in the radar regime.

The PI has published two papers on the interaction of EM waves with PBG structures: (1) M. Elson and P. Tran, "Coupled-mode calculation with the R-matrix propagator for the dispersion of surface waves on a truncated photonic crystal," *Phys. Rev. B* **54**, pp. 1711-1715 (1996) and (2) M. Elson and P. Tran, "Band structure and transmission of photonic media: A real-space finite-difference calculation with the R-matrix propagator," in Photonic Band Gap Materials, NATO ASI Series E: Applied Sciences Vol. 315, ed. C. M. Soukoulis, pp. 341-354 (1996).

APPROACH

Referring to the schematic below, we will model a PBG structure as a periodic array of square (or round) dielectric rods of infinite length (perpendicular to page) and infinitely periodic in x -direction. The dimension in the z -direction can be either semi-infinite or finite. We will perform a theoretical calculation to determine the band gap of a PBG structure. For this PBG structure, a long antenna (denoted by black dot) operating at a frequency within the band gap will be situated on the PBG surface and the radiation pattern calculated. We will also look for possible coupling to surface wave modes which might be supported by the PBG structure. We will use an integral equation solution to Maxwell's equations and solve these equations numerically. Numerical results will be generated for several PBG configurations.

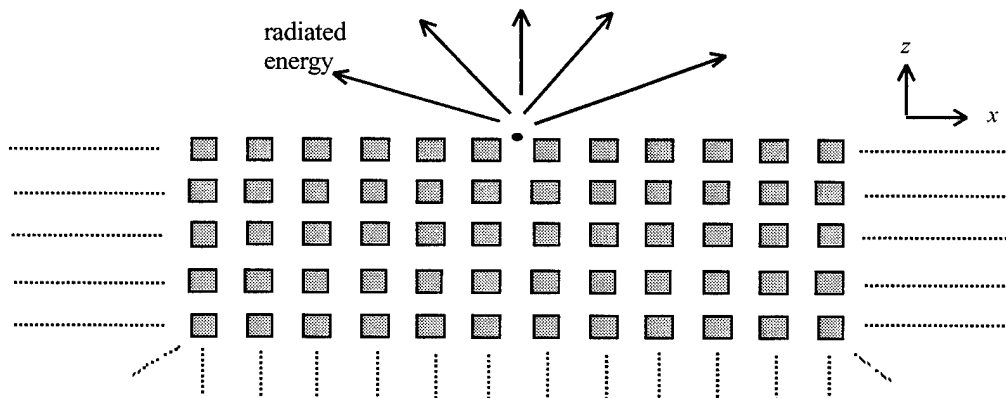

EXPECTED RESULTS

We expect to determine the radiation pattern of an antenna array which is flush mounted on a PBG structure. Milestones include, theory development, numerical results, and computer code and documentation.

EXTERNAL RELATIONSHIPS

DARPA, Elliot Brown, Eli Yablonovich (UCLA)

PROJECT 4
DISCRETIONARY FUNDS REQUEST FORM

Circle One: B&P MSI Core S&T IR Dept. Priority #

Project Title: Surfacewave (Wire/Laser Induced) RF Path

Principal Investigator: Ron Skatvold/Dan Garcia **FY:** 99 **\$K:** 25
 Code Ext. Bldg./Room Dept. FMA Man-years (1750 Hrs)
 472210D 939-8915 1400/B17 Pam Siberberg .3

OBJECTIVE

The objective is to investigate and develop a special class of surface wave transmission line that has the potential to revolutionize radar applications.

NEED AND BACKGROUND

In the early 1950's, the development of a surface wave transmission line was developed. This transmission line called a G-Line, guided RF energy on a single dielectric coated wire. The advantages included the ease of stringing a single wire and RF transmission losses were very low. A simple transducer located at each end of the strung wire provided the transition from the guided mode to TEM coaxial cable. The theory describing the guided electromagnetic fields on the dielectric coated wire as a transmission line was well developed. The guided fields were almost entirely confined to the wire and there was very little radiation.

The prominent application discussed here is not the transmission (forward transfer function), but the reflection characteristics. That is, using a single transducer and measuring the reflection characteristic at the end of the wire where it intersects with a discontinuity, a radar function is derived that specifically directs the reflected point with no backlobes or sidelobes, which are generally associated with radars that use antennas. In recent developments, it has been shown that the conductive path, similar to the coated wire, can be induced with lasers. An obvious question is, if a laser induced path guided the RF for radar applications, why not use the characteristics of the laser by itself as the radar (ladar)? Good question! The intent here is to investigate the scattering or reflection characteristic at the RF frequency, not the laser frequency. A good example is a bunker radar. The frequency of the radar must penetrate the ground at some depths and still contend with clutter and potential jamming. Using the laser induced path, the RF radar

could be precisely pin pointed and the reflection characteristics at the discontinuity (the ground) examined in the time (distant) domain while avoiding unwanted clutter and jammers.

APPROACH

The approach for this effort is to exploit the use of the G-Line transmission line for small handheld or mobile radars for localized applications. The development will focus on the scattering characteristics at the point where the G-Line intersects with a discontinuity. Also, propagation analysis will be developed to exploit the use of a laser induced path. This work will be coordinated with a proposal submitted to the EO-Net to investigate the laser path.

EXPECTED RESULTS

If proven successful, this blending of laser and RF technology could revolutionize radar for targeting and weapons delivery.

EXTERNAL RELATIONSHIPS

EO-Net

PROJECT 5
DISCRETIONARY FUNDS REQUEST FORM

Circle one: B&P MSI Core S&T Div. Priority #:

Project Title: Low Noise Exciter for mmW Seekers

Date of proposal: 9/1/98 **FY:** 99 **\$K:** 20

Project Leaders	Code	Ext.	Location	MYrs
Curtis Kidner	472220D	939-8259	Mich Lab/ S45	0.2
Marko Afendykiw	472220D	939-2845	Mich Lab/ S41	0.1

OBJECTIVE

To demonstrate a resonator critical technology for the synthesis of very low phase noise mmW frequency reference.

NEEDS AND BACKGROUND

Future high performance mmW systems, such as in hit-to-kill TBMD systems, phased arrays and precision guided weapons will require extremely low phase noise exciters to minimize the effects of sidelobes and clutter. State-of-the-art in low-noise frequency exciters use an architecture based on frequency addition and multiplication, with the critical low noise element being extremely stable single-frequency oscillators. For future mmW systems, this exciter architecture will not suffice. The added noise power of seeker compatible Ka-band amplifiers, demonstrated under Marko's supervision, is better than the phase noise performance of the current exciter technology.

The critical technology for a low phase noise exciter is a very high Q ($>10^6$) resonator. A design called "magic mirrors" was recently reported that has the potential to achieve the required Q. Using this technique, an unloaded Q of 5×10^5 was observed at 18 GHz. Theory predicts that with further work the cavity is capable of achieving the required Q.

APPROACH

The cavity will be theoretically studied and designed using an electromagnetic field simulation package (HFSS). An appropriate design will be chosen, and a prototype resonator will be fabricated and tested in house.

EXPECTED RESULTS

Demonstrate a Ku-band resonator with $Q > 10^6$.

This page intentionally left blank.

Appendix C

FINAL REPORTS FOR FY99 CORE S&T PROJECTS

(The reports contained in this appendix are reproduced in facsimile.)

This page intentionally left blank.

PROJECT 1
FY99 RF NETWORK PROGRESS REPORT

Linda F. Johnson and Mark B. Moran
Naval Air Warfare Center Weapons Division

BREAKDOWN OF FUNDING

In FY99 this project received \$50K of 6.2-direct funding from the Office of Naval Research (ONR) in addition to \$20K of Core S&T funding from the RF Network. After fabricating and analyzing more than 200 films in the past two years, it is difficult to provide an exact breakdown of what was accomplished with each source of funding. However, the investigators did try to comply with ONR guidelines which state that 6.2 funds should be used to develop materials for a particular application while discretionary Core S&T funds can be used for a variety of purposes including basic research, training and attending conferences. The goals of the 6.2-funded effort were very specific; optimize the CuAl_xO_y films for transparency in the mid-wave infrared (IR), achieve a sheet resistance of 10 ohms/cm² or lower, deposit optimized films onto sapphire substrates and measure the durability in suitable rain- and sand-erosion tests. The goals of the Core S&T project were much less specific and included understanding why the films exhibited enhanced electrical conductivity along with optical transparency at a variety of wavelengths from the visible to the far IR. To comply with ONR guidelines, the \$50K of 6.2-direct funds were used on more applied aspects like trouble-shooting equipment problems, purchasing materials and supplies, and contracting for analytical services that are not available in-house like electron spectroscopy for chemical analysis (ESCA). In contrast, Core S&T funds were used to address more fundamental 6.1-basic-research issues like understanding the relationship between the electro-optical properties and the molecular structure of the CuAl_xO_y films. In addition, Core S&T funds were used to cover the investigators' labor while they received training on the center's new atomic force microscope (AFM). The AFM was used recently to reveal important features in the microstructure of one of the most electrically conductive films. Core S&T funds also covered labor charges while the principal investigator attended the *Fall 98 Materials Research Society Meeting* where a paper was presented.

ADDITIONAL BACKGROUND INFORMATION

A novel class of complex metal oxides that have potential as transparent conductive oxides (TCOs) for electro-magnetic-interference (EMI) shielding on IR-seeker windows and missile domes has been identified. They also have potential as durable, lightweight radar absorbing materials (RAM) that in thin-film form could absorb strongly over a

broad range of microwave and radio frequencies. These complex metal oxides exhibit the rhombohedral (R3m) crystalline structure of naturally occurring delafossite, CuFeO_2 . The general chemical formula is ABO_2 where A is a monovalent metal (Me^{+1}) like Cu, Ag, Au, Pt, or Pd while B is a trivalent metal (Me^{3+}) like Al, Fe, Ti, Cr, Co, Ni, Cs, Rh, Ga, Sn, In, Y, La, Pr, Nd, Sm, or Eu. Not all combinations are possible. For example, Pt is stable with only Co so only PtCoO_2 is possible. Pd is stable only with Cr, Co or Rh so PdCrO_2 , PdCoO_2 or PdRhO_2 are the only possible compounds.

Single crystals of delafossite metal oxides exhibit very anisotropic electrical properties. Specifically, the electrical conductivity is very high in the direction perpendicular to the c-axis and is orders of magnitude lower in the c-direction. In the delafossite-type structure shown in Figure 1, the long axis of the diagram corresponds to the c-axis. It is easy to see how very anisotropic electrical behavior could result from this atomic arrangement. Perpendicular to the c-axis, there are layers of A^+ cations, one-atomic dimension in thickness, that are essentially metallic in nature. The A-atom metallic layers are sandwiched by and covalently bound to layers of octahedrally coordinated B^{3+} ions by O-A-O dumb-bells. The sheets of metallic layers enhance electrical conductivity in the direction perpendicular to the c-axis while the oxygen atoms retard electrical conductivity in the direction parallel to the c-axis.

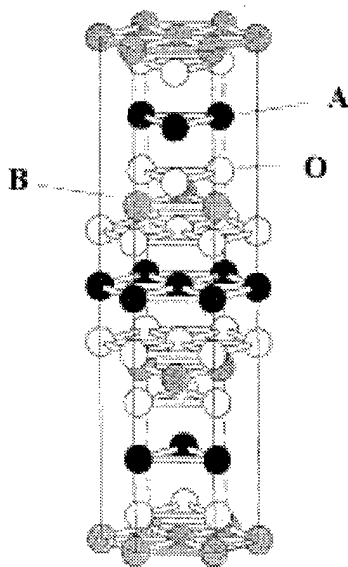

Figure 1. Arrangement of atoms in the delafossite-type structure [From M. Tanaka, et al, *Physica B*, Vol. 245, pp. 157-163 (1998).]

Except for recent work on laser-ablated thin-films of p-type CuAlO_2 [Kawazoe, et al. *Nature*, Vol. 389, p. 939 (1997)], only bulk powders and single crystals of the delafossite metal oxides have been studied. In addition, there have been no attempts to understand the molecular structure and chemical composition in terms of Fourier transform infrared (FTIR) or electron spectroscopy for chemical analysis (ESCA) except for recent work on sintered powders of PdCoO_2 [M. Tanaka, et al, *Physica B*, Vol. 245, pp. 157-163 (1998).] ESCA reveals information about the ionic charge and valence state of an atom in a molecule; the binding energy shifts to a higher value as the valence state or ionic charge increases. FTIR spectroscopy reveals information about molecular bonds and bond order; stretching frequencies shift to higher energies with increasing bond order and to lower energies with increasing mass. Understanding the chemical bonds and atomic valencies in the metal oxide delafossites will lead to a more detailed understanding of the distribution of electron density. An understanding of the distribution of electron density is needed to predict properties like optical absorption, electrical conductivity and magnetic susceptibility. Better understanding of molecular and electronic band structure will increase the chances for developing new and improved materials for a variety of applications including photovoltaics, superconductors, RAM and EMI-shielding. Without the support of the RF Network, the investigators would not have been able to spend as much time on the fundamental aspects of this research. A better understanding of the relationship between the electro-optical properties and the molecular structure of the delafossites has also made marketing this effort easier.

PROGRESS

Thin films of CuAl_xO_y were deposited by reactive magnetron co-sputtering from the high-purity-metal targets. Fourier transform infrared (FTIR) and electron spectroscopy for chemical analysis (ESCA) were used to understand the relationship between the electro-optical properties and the molecular structure of the CuAl_xO_y films. Weak FTIR absorption bands at 1470 and 1395 cm^{-1} (6.80 and $7.17\mu\text{m}$) are present only in films that exhibit enhanced electrical conductivity. When these bands are absent, the CuAl_xO_y films have high values of resistivity. It is possible that the enhanced conductivity of sputter-deposited CuAl_xO_y films could be a result of the overlapping d-orbitals on neighboring Cu^{1+} atoms in the plane perpendicular to the c-axis of the delafossite unit cell. Overlapping d-orbitals also would explain why the sputter-deposited CuAl_xO_y films absorb strongly in the visible. Another possibility is that the 1470 and 1395 cm^{-1} bands involve vibrational modes of the entire Cu-O-Al-O-Cu sequence along the c-axis of the delafossite unit cell. Cuprous oxide (Cu_2O) absorbs strongly at 609 cm^{-1} ($16.4\mu\text{m}$). Randomly oriented Al_2O_3 has a strong absorption centered at about 670 cm^{-1} ($14.9\mu\text{m}$) with shoulders at 560 and 750 cm^{-1} (17.9 and $13.3\mu\text{m}$). The fact that the frequencies of the 1470 and 1395 cm^{-1} bands are about twice those of the major phonons in Cu_2O and Al_2O_3 is significant and indicates that these modes probably have some double-bond character.

Double bonds tend to enhance electron mobility. Understanding the origin of the bands at 1470 and 1395cm^{-1} could accelerate the development of CuAl_xO_y as a wide bandgap conductive oxide since the bands are clearly associated with enhanced electrical conductivity and carrier mobility. In FY00, the investigators plan to deposit films of CuFeO_2 , CuYO_2 and CuCrO_2 in addition to continuing the optimization of the CuAlO_2 films. As the mass of the trivalent metal atom increases from that of Al (26 amu) to that of Y (89 amu), it should be possible to correlate the frequency shifts in the FTIR spectra and assign the 1470 and 1395cm^{-1} bands to double-bond-stretching modes with greater certainty.

Figure 2 is a high-resolution-ESCA spectrum for one of the CuAl_xO_y films with the highest electrical conductivity and the most IR transparency. The spectrum has been de-convolved into three distinct peaks with the Cu 3p1 peak at 79.36eV contributing about 12%, the Cu 3p3 peak at 77.43eV contributing about 28.5% and the Al 2p peak at 74.76eV contributing about 59.5%. Without standards, ESCA is only semi-quantitative. However, the high-resolution ESCA spectrum clearly shows that the film is Al-rich. More quantitative compositional analysis was obtained using inductively coupled plasma (ICP) emission spectroscopy. The ICP data indicates a Al:Cu ratio of about 2:1. Even with a very non-stoichiometric composition, the CuAl_xO_y film is very conductive and IR transparent with a sheet resistance of 246ohm/cm^2 , a resistivity value of 0.0051ohm-cm and a peak transmission of 67% at a wavelength of $3.6\mu\text{m}$. The broad phonon absorption in the FTIR spectrum of the CuAl_xO_y film resembles that of randomly oriented Al_2O_3 indicating that the excess Al is bonded to oxygen. An excess of Al-O bonds should make the CuAl_xO_y films extremely durable since Al_2O_3 is a very hard material. However, too many Al-O bonds will eventually degrade the electrical conductivity.

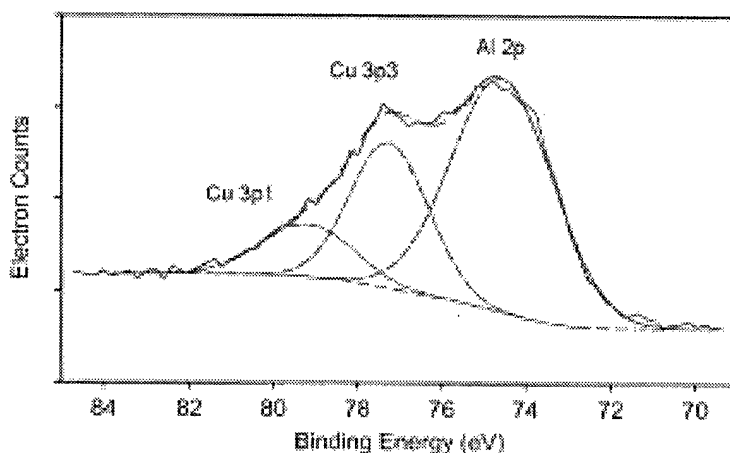

Figure 2. High-resolution ESCA spectrum of a CuAl_xO_y film showing the de-convolved peaks for Cu 3p1 at 79.36eV , Cu 3p3 at 77.43eV and Al 2p at 74.76eV .

Atomic force microscopy (AFM) and high-resolution electron microscopy (HREM) indicate that magnetron-sputter-deposited CuAl_xO_y is not a single-phase material. A second Cu-rich phase appears to be contributing to the enhanced electrical conductivity. Figure 3 is an AFM showing topographical-height information for a CuAl_xO_y film deposited onto a glass microscope slide. The image is fairly typical of an inorganic metal oxide showing small grains of material with diameters in the range of 10 to 80 nm.

Figure 4 is the identical field of view shown in Figure 3 but with electric-potential information displayed. This mode of operation is called electric force microscopy (EFM) and involves applying a potential to the tip of the probe and measuring the bias induced on the sample. The EFM mode can only be used on samples that are electrically conductive. If an area on the sample is electrically conductive, no bias is induced and the measured surface potential is zero. If an area on the sample is electrically insulating, a bias will be induced and the measured surface potential will have a non-zero value. In the EFM shown in Figure 4, the dark areas correspond to areas that are electrically conductive and the light areas correspond to areas that are electrically insulating. In general, the larger grains appear to be more conductive than the smaller grains, suggesting that the larger grains involve a second Cu-rich phase. It is likely that the Cu-rich grains are a result of diffusion of a 100-Å-thick layer of copper that was deposited onto the substrate and then over-coated with about 3000 Å of CuAl_xO_y .

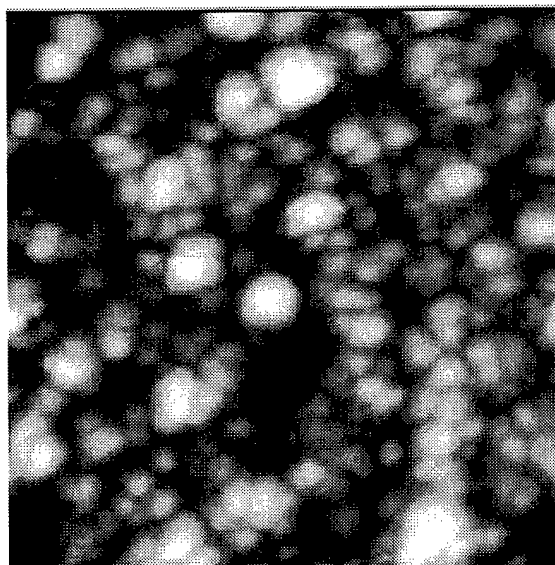

Figure 3. Atomic force micrograph (134,000X) displaying topographical-height information for a CuAl_xO_y film deposited onto a glass microscope slide. The white features have a maximum height of about 90nm. The field of view is 500 x 500nm.

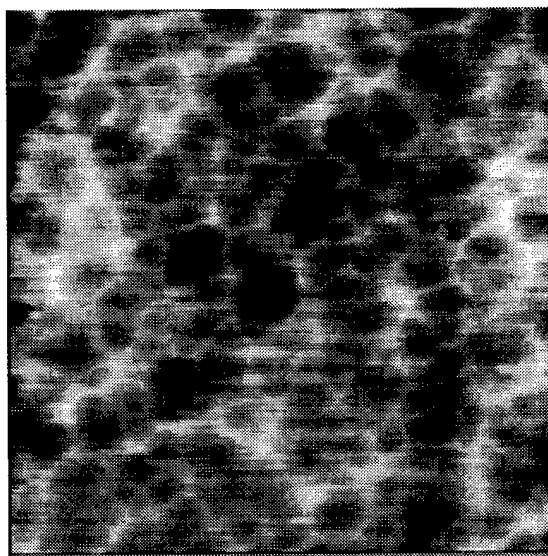

Figure 4. Electric force micrograph (134,000X) displaying electric-potential information for the surface of a CuAl_xO_y film deposited onto a glass microscope slide. The black areas are electrically conductive and the white areas are electrically insulating. The identical field of view is shown in Figure 3.

Like the AFM images shown in Figure 3 and 4, the HREM images shown in Figures 5 and 6 also indicate that the CuAl_xO_y consists of islands of cubic-copper crystallites in a Cu-Al-O matrix. Electron energy loss spectroscopy (EELS) was used to show that the dark spots in the bright field image in Figure 5 are cubic-copper crystallites. Figure 6 is simply a dark field image where the light spots are now the cubic-copper crystallites.

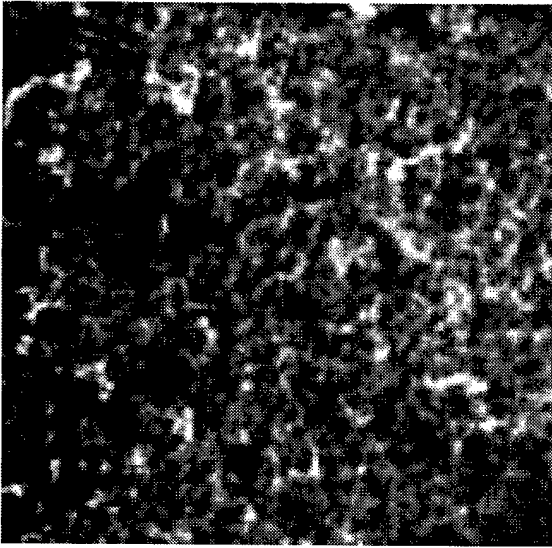

Figure 5. High-resolution electron micrograph (150,000X) of a CuAl_xO_y film (bright field image).



Figure 6. High-resolution electron micrograph (150,000X) of a CuAl_xO_y film (dark field image).

PROJECT 2
FRACTAL RADIATORS FOR MULTIBAND/BROADBAND USE
PROGRESS IN FISCAL YEAR 1999

P. L. Overfelt
Research Department

This project was divided into two parts, an engineering part and a mathematical analysis part. The engineering part of the project focused on "band-limited" fractals or prefractals [1] (the iteration number is always finite) and on obtaining an answer to the question, "Can an electrically small fractal antenna radiate more efficiently and with greater bandwidth (or at least operate at multiple frequencies) than its Euclidean geometry counterpart?" The answer is a qualified yes.

It is well known that electrically large loops and electrically long wires are good radiators in general, and correspondingly that electrically small loops and electrically short wires are much poorer radiators in general. Unfortunately for many missile and aircraft applications, the space available for the antenna is both physically and electrically very small.



In terms of Euclidean geometry, electrically long wires or large loops which are "good" radiators take up correspondingly large areas. This can be seen by considering Table 1. In Table 1 it is apparent that for any planar Euclidean shape, its area is proportional to its perimeter squared. Thus as its perimeter increases, the amount of area it requires increases also. So it is virtually impossible when considering only Euclidean shapes to create an electrically small but still "good" radiator without resorting to matching networks, etc.

This relationship is not true for many planar fractal shapes. In Table 2, the first three iterations of the square Koch island fractal are shown. Between the zeroth iteration and the first iteration of this planar fractal shape, it is shown that its perimeter increases by 50% while its area decreases by 25%. Between the zeroth and second iterations, its perimeter has increased by more than 250% while its area has decreased by approximately 40%. Thus because of its "area-filling" nature, a fractal radiator can be electrically long but still take up much less area than its Euclidean counterpart. Depending on the number of fractal iterations taken (we assume that there is always some finite upper limit to this type of "band-limited" fractal), it is also possible to operate the fractal antenna at a number of different frequencies whereas the typical electrically small antenna is usually resonant and can operate at only one frequency.

The problem of mutual coupling between different parts of the fractal shape was considered. It was determined that the nature of the coupling depends on the distance between sections and the individual geometry of the specific structure [2]. By modeling the fractal shape as an array of dipole elements, the role of the propagating and evanescent wave fields of a dipole source has been considered [3].

For a finite number of iterations of a fractal shape, the object produced is simply a collection of line segments with finite measurable length. These objects formed *en route* to a true fractal object are the “band-limited” fractals or prefractals from above. The mathematical analysis portion of the project focused on true fractals where infinite numbers of iterations are assumed. It was determined that there are possible direct fractal solutions to Maxwell’s equations if the definition of a solution to a partial differential equation (PDE) is relaxed somewhat. When the concept of generalized functions (for example, the Dirac delta function is one of the best known examples of a generalized function is employed [4,5]), it can be shown that under certain conditions, the complex Weierstrass-Mandelbrot function (which is a true fractal) is also a generalized solution to the Helmholtz equation and Maxwell’s equations [6]. It has been shown also that a Fourier series can be decomposed (at least formally) into an infinite sum of Weierstrass-Mandelbrot functions [7].

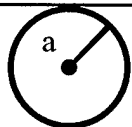
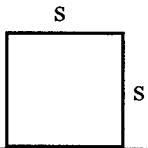
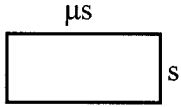
TABLE 1. Perimeter vs Area for Planar Euclidean Shapes.

Shape		Area	Perimeter	Relationship
Circle		πa^2	$2\pi a$	$A = \frac{P^2}{4\pi}$
Square		s^2	$4s$	$A = \frac{P^2}{16}$
Rectangle ($\mu > 1$)		μs^2	$2s(1+\mu)$	$A = \frac{\mu}{4(1+\mu)^2} P^2$
Equilateral Triangle		$\frac{\sqrt{3}}{4} s^2$	$3s$	$A = \frac{1}{12\sqrt{3}} P^2$

As the perimeter increases, the area must increase.

TABLE 2. Perimeter vs Area for the Square Koch Island Fractal.

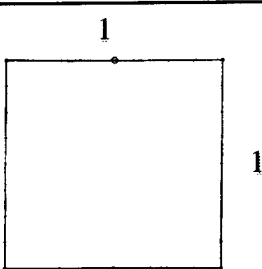
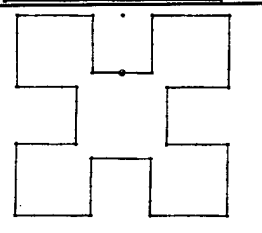
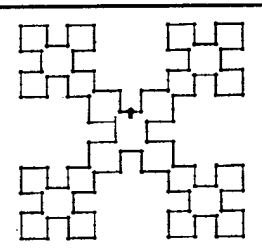
	Iterations	Perimeter	Area
	0	4.0	1.0
	1	6.0	0.75
	2	10.5	0.59375

REFERENCES

1. P. S. Addison, *Fractals and Chaos* (Institute of Physics Publishing, London, 1997).
2. P. L. Overfelt, "Two Approaches to Single Element Fractal Antenna Analysis" (White Paper), NAWCWD Memo 3900, 4T4120D/001, Office of Naval Research, Oct. (1999).
3. P. L. Overfelt, "Analytic series solutions for decomposition of the point-dipole field into homogeneous and evanescent parts", in progress, Nov. (1999).
4. E. Zauderer, *Partial Differential Equations of Applied Mathematics* (Wiley, New York, 1983).
5. M. J. Lighthill, *Introduction to Fourier Analysis and Generalized Functions* (Cambridge University Press, London, 1964).

6. P. L. Overfelt, "Weierstrass-Mandelbrot functions as generalized solutions to Maxwell's equations", NAWCWD Memo 3900, 4T41200D/004 (Feb., 2000).
7. P. L. Overfelt and D. J. White, "On decomposing a Fourier series into a sum of Weierstrass-Mandelbrot functions", NAWCWD Memo 3900, 4T4120D/005 (Mar., 2000).

PROJECT 3
CALCULATION OF RADIATION FROM A LONG ANTENNA
MOUNTED ON A PHOTONIC CRYSTAL SUBSTRATE

J. Merle Elson
Naval Air Warfare Center Weapons Division
Research Department
Computational Sciences Division
China Lake, CA 93555

ABSTRACT

Perfectly Matched Layer (PML) boundary conditions and the R-matrix propagator algorithm are used with a finite-difference frequency-domain modal-expansion approach to calculate antenna radiation. The antenna is mounted adjacent to a finite-sized photonic crystal (PC) substrate. Because of the PC periodicity, frequency band gaps can exist in analogy with electronic crystals. When the antenna is driven at a frequency within the band gap, the PC is an excellent reflector. Numerical results for antenna gain are given.

1. INTRODUCTION

We model a photonic crystal (PC) as shown by the schematic of Fig. 1. The square-cross-section dielectric rods have permittivity ϵ_r and are embedded in a background medium of permittivity ϵ_b . The top layer of the PC from $z = L_c$ to $z = L_c + h$ is the antenna layer with permittivity ϵ_b except for the antenna, which has permittivity ϵ_a . The gray areas near the left and right x limits are the Berenger Perfectly Matched Layer (PML) [1] absorbing regions which simulate an infinite spatial domain and facilitate numerical calculation by preventing unwanted reflection from the edges of the computational domain.

The overall dimensions of the PC are typically many wavelengths in length and because of the periodic nature of the PC, we know that solutions will generally contain evanescent as well as propagating waves. The R-matrix propagator method [2-6] is numerically stable and well suited for problems having computational domain sizes that are many wavelengths in dimension. In this paper we summarize an implementation of Berenger's PML formalism with the R-matrix method.

2. MAXWELL'S EQUATIONS AND PML LAYERS

Referring to the PC-antenna schematic in Fig. 1, the horizontal dashed lines separate regions (sublayers) which are z invariant. Within any sublayer we can find solutions to Maxwell's equations and the R-matrix algorithm is then used to relate solutions between various sublayers. The rectangular antenna lies flush with the top layer of the PC and the antenna current will be assumed to have only a y component. The superstrate $z \geq L_x + h$ and substrate $z \leq 0$ regions are homogeneous and vacuum.

In the context of a finite-difference-time-domain approach, Berenger [1] incorporated impedance-matched absorbing boundary layers into Maxwell's equations. The present work is done in the frequency domain, but we similarly incorporate absorbing layers in the vicinity of the x limits of the PC region. We assume $\exp(-i\omega t)$ time dependence and all dielectric media to be intrinsically loss free. Described in more detail in Ref. [6], we find that for electric polarization along the direction of the antenna (y direction), the electric field satisfies the second order differential equation given by

$$\frac{\partial^2 E_y(x, z)}{\partial z^2} = -\frac{i\omega}{c} \frac{4\pi}{c} J_y(x) - \left(\frac{\omega}{c}\right)^2 \epsilon(x) E_y(x, z) - \frac{\epsilon(x)}{\epsilon_x(x)} \frac{\partial}{\partial x} \left[\frac{1}{\mu_x(x)} \frac{\partial E_y(x, z)}{\partial x} \right] \quad (1)$$

where $J_y(x)$ is the antenna current and we define $\epsilon_x(x) = \epsilon(x) + 4\pi i \sigma_x(x)/\omega$ and $\mu_x(x) = 1 + 4\pi i \sigma_x^*(x)/\omega$. We have made simplifying assumptions about the material parameters where the permittivity $\epsilon(x)$, electric $\sigma_x(x)$, and magnetic $\sigma_x^*(x)$ conductivity, are independent of coordinate z . Since the material parameters in Eq. (1) are z -invariant, then solutions to Eq. (1) will be valid in any z -invariant region of the PC structure. Outside of any PML region, the $\sigma_x = \sigma_x^* = 0$, and Eq. (1) reduces to the usual wave equation. The antenna current is also independent of z and is zero everywhere except in the topmost layer. Impedance matching requires that we set $\sigma_x/\epsilon = \sigma_x^*$.

The finite difference part of this work comes from discretizing the x dimension into N segments each having length $\Delta x = L/N$ and writing the x derivatives in Eq. (1) as a centered finite-difference approximation. This yields

$$\begin{aligned} \frac{\partial^2 E_y(x, z)}{\partial z^2} = & -\frac{i\omega}{c} \frac{4\pi}{c} J_y(x) - \left(\frac{\omega}{c}\right)^2 \epsilon(x) E_y(x, z) \\ & - \frac{\epsilon(x)}{\Delta x^2 \epsilon_x(x)} \left\{ \frac{E_y(x + \Delta x, z) - E_y(x, z)}{\mu_x(x + \Delta x/2)} + \frac{E_y(x - \Delta x, z) - E_y(x, z)}{\mu_x(x - \Delta x/2)} \right\} \end{aligned} \quad (2)$$

The x coordinate is now a discrete variable, but the z coordinate remains a continuous variable. Since Eq. (2) is valid at any one of N discrete points x , we have N coupled

differential equations to solve for each sublayer. Considering all N differential equations together for any sublayer, the coupled equation system may be concisely written in matrix form as

$$\frac{\partial^2 E(z)}{\partial z^2} = \mathbf{M}E(z) + \Phi \quad (3)$$

where $\Phi = -4\pi\omega J_y(x)/c^2$. The $N \times N$ square matrix \mathbf{M} is obtained from Eq. (2) and in Eq. (3), explicit x dependence notation and y component notation has been omitted and is understood. The electric field $E(z)$ and source term Φ are N -element column vectors where each element corresponds to a discrete coordinate x . Since \mathbf{M} and Φ are independent of z , the solution for the fields in any z invariant region is straightforward by diagonalization of \mathbf{M} as $\mathbf{S}^{-1}\mathbf{M}\mathbf{S} = \lambda^2$, and this yields the modal solutions

$$E(z) = \mathbf{S}(\exp(\lambda z)\mathbf{C}_+ + \exp(-\lambda z)\mathbf{C}_-) - \mathbf{M}^{-1}\Phi \quad (4)$$

$$B(z) = \left(\frac{ic}{\omega}\right)\mathbf{S}\lambda(\exp(\lambda z)\mathbf{C}_+ - \exp(-\lambda z)\mathbf{C}_-) \quad (5)$$

The λ and $\exp(\pm\lambda z)$ are $N \times N$ diagonal matrices. Matrix λ has non-zero elements that are the square roots of the eigenvalues λ^2 . The non-zero elements of $\exp(\pm\lambda z)$ are exponential terms and \mathbf{C}_\pm are column vectors of constants. The \mathbf{R} matrix algorithm provides the relationship between the field solutions across many sublayer boundaries including the superstrate and substrate. The final linear equation system is written

$$\begin{pmatrix} \mathbf{I} - \mathbf{R}_{11}(L_z + h)\hat{\mathbf{Z}}^- & -\mathbf{R}_{12}(L_z + h)\hat{\mathbf{Z}}^+ \\ -\mathbf{R}_{21}(L_z + h)\hat{\mathbf{Z}}^- & \mathbf{I} - \mathbf{R}_{22}(L_z + h)\hat{\mathbf{Z}}^+ \end{pmatrix} \begin{pmatrix} E(0) \\ E(L_z + h) \end{pmatrix} = - \begin{pmatrix} -\mathbf{R}_{12}(L_z)(\mathbf{r}_{11}(h) - \mathbf{R}_{22}(L_z))^{-1}\mathbf{M}_a^{-1}\Phi \\ (\mathbf{I} - \mathbf{r}_{21}(h)(\mathbf{r}_{11}(h) - \mathbf{R}_{22}(L_z))^{-1})\mathbf{M}_a^{-1}\Phi \end{pmatrix} \quad (6)$$

where \mathbf{I} is the identity matrix, \mathbf{Z}^\pm are impedance matrices [6], $\hat{\mathbf{Z}}^\pm = \mathbf{F}\mathbf{Z}^\pm\mathbf{F}^{-1}$, and \mathbf{F} is a Fourier transform matrix. The \mathbf{R}_{ij} and \mathbf{r}_{ij} are \mathbf{R} matrices. [6] Equation (6) may be solved to yield the real-space electric field E distribution along the $z = 0$ and $z = L_z + h$ interfaces. From the electric field E solutions to Eq. (6) for $z = 0$ or $z = L_z + h$, we can calculate the angular distribution of reflected and transmitted energy.

3. NUMERICAL RESULTS

For numerical analysis, we consider the PC-antenna configuration shown in Fig. 1 where the dielectric rods have permittivity $\epsilon_a = (9,0)$, the background is $\epsilon_b = (1,0)$, and the wire antenna is $\epsilon_w = (-100,30)$. The period of the PC in the x and z directions is $a = 1.87\lambda$ and the side dimension of the square rods is given by the fill factor of 0.156 or $w = 0.395a$.

The PC consists of 37 periods in the x direction or $L_x = 37a$ and 6 whole periods in the z direction or $L_z = 6a$. The dimensions of the rectangular antenna are width 0.5λ and height 0.2λ . The discretization $N = 701$ yielding a spatial resolution of $\Delta x = L_x/N = 0.0987\lambda$. The PML region on each side of the PC consists of 30 layers for a total thickness of $30\Delta x$. The band structure diagram in Fig. 2 shows that the band gap for an infinite PC approximately spans $\omega/c = 0.32(2\pi/a) \rightarrow 0.43(2\pi/a)$. In Fig. 3, we show a normalized radiation pattern calculated for a frequency $\omega/c = 0.38(2\pi/a)$, which is within the band gap. The normalizing is done by calculating the radiation pattern with the PC removed and then dividing these corresponding values into the corresponding radiation pattern calculated with the PC not removed. In this way, we really calculate antenna gain. Since the frequency is within the band gap and there is no transmitted radiation. For comparison, the dotted line shows the calculated result for reflected radiation with the PC replaced by a thick metal film having the same permittivity as the wire antenna. This radiated intensity is slightly less than that for the PC because of absorption by the metal.

4. CONCLUSIONS

We have calculated the radiation pattern from a long antenna that is flush mounted atop a finite-sized photonic crystal substrate. The photonic crystal is modeled by a finite sized array of square dielectric rods. The lateral limits of the array are truncated with perfectly matched absorption layers. Modal expansion solutions to Maxwell's equations are obtained in the frequency domain using the R-matrix propagator and finite difference derivative approximations.

The numerical results indicate that for a frequency within the band gap, the radiation pattern is very similar to that for a metallic substrate. This indicates that use of a PC in place of a metal would emulate the radiation characteristics of a metal substrate, but the big advantage would be preventing potential heat damage. It has been estimated that heat absorption for a PC relative to a Cu metal substrate would be about two orders of magnitude less. [7]

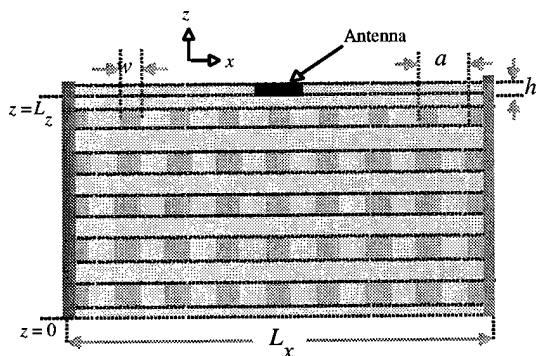

Figure 1. Schematic showing modeling of photonic crystal (PC) and antenna. The crystal is periodic in both the x and z directions. The dark shaded squares are the dielectric rods of side width w and the antenna is the black rectangle, of thickness h , in the topmost layer.

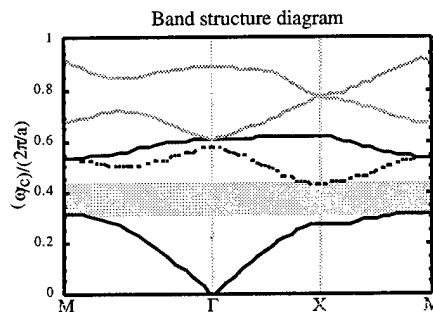

Figure 2. Band structure diagram for a two-dimensional PC with the electric field polarized parallel to the rods. The PC parameters are the same as in Fig. 1 except the dimensionality is extended to infinity in the x and z directions. The horizontal shaded area indicates a complete band gap.

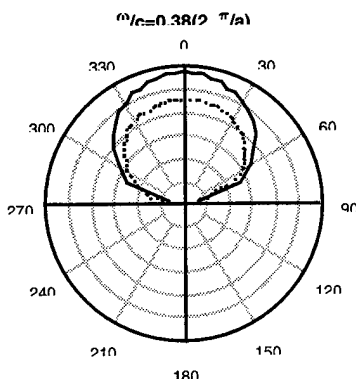

Figure 3. Calculated antenna gain versus radiation angle relative to an isolated wire antenna at frequency $\omega/c = 0.38(2\pi/a)$, which is within the band gap. The normalization values associated with the isolated antenna are obtained by omitting the PC structure and calculating the radiation pattern when the wire antenna is surrounded by free space. The solid curve corresponds to a PC configuration as shown in Fig. 1. For comparison, the dotted curve shows the corresponding calculation where the PC region $z \leq L_z$ is replaced by a metal with permittivity identical to that of the antenna.

REFERENCES

- [1] Jean-Pierre Berenger, "A perfectly matched layer for the absorption of electromagnetic waves," *J. Comp. Phys.* 114, pp. 185-200 (1994); Jean-Pierre Berenger, "Three-dimensional perfectly matched layer for the absorption of electromagnetic waves," *J. Comp. Phys.* 127, pp. 363-379 (1996).
- [2] J. M. Elson, and P. Tran, "Dispersion and diffraction in photonic media: A different modal expansion for the **R**-matrix propagation technique," *J. Opt. Soc. Am. A* 12, 1765-1771 (1995).
- [3] J. M. Elson, and P. Tran, "Coupled mode calculation with the **R**-matrix propagator for the dispersion of surface waves on a truncated photonic crystal," *Phys. Rev. B* 54, 1711-1715 (1996).
- [4] J. M. Elson, and P. Tran, "Band structure and transmission of photonic media: a real-space finite-difference calculation with the **R**-matrix propagator," in *Photonic Band Gap Materials*, Vol. 315, *NATO Advanced Study Institute Series E: Applied Sciences*, edited by C. M. Soukoulis (Kluwer, Dordrecht, 1996), pp. 341-354
- [5] Lifeng Li, "Multilayer modal method for diffraction gratings of arbitrary profile, depth, and permittivity," *J. Opt. Soc. Am. A* 10, pp. 2581-2591 (1993).
- [6] J. M. Elson, "Calculation of radiation from a long antenna that is situated on a photonic crystal substrate," submitted to IEEE AP.
- [7] E. R. Brown, O. B. McMahon, C. D. Parker, C. Dill III, K. Agi, and K. J. Malloy, "Microwave applications of photonic crystals", in *Photonic Band Gap Materials*, Vol. 315, *NATO Advanced Study Institute Series E: Applied Sciences*, edited by C. M. Soukoulis (Kluwer, Dordrecht, 1996), pp. 355-375

PROJECT 4
SURFACE WAVE (WIRE/LASER INDUCED)
RF PATH

Ron Skatvold and Dan Garcia

The authors did not submit any progress in FY99 for this project.

PROJECT 5
LOW NOISE EXCITER FOR MILLIMETERWAVE SEEKERS

Curt Kidner

This project was not carried out. Its funding was returned to the RF Network.

This page intentionally left blank.

Appendix D

RF S&T NETWORK RETREAT MINUTES

(The reports contained in this appendix are reproduced in facsimile.)

This page intentionally left blank.

**RF S&T NETWORK
RETREAT MINUTES
9/28/99**

Time: 0900 - 1630.
Place: NAWS Conference Center, China Lake.
Attendees:

China Lake: West Katzenstein, Pam Overfelt, Tex Hoppus, Don Bowling,
Mike Neel, and Ron Skatvold.
Point Mugu: Scott Kujiraoka, Marv Ryken, and Piotr Adamski

(Note: These minutes document the ideas, concerns and issues generated at the RF S&T Retreat. They are to be used as only a beginning for future discussion of the topics covered herein. Some conclusions from the topics addressed will have to be derived at a later date.)

Purpose-

The purpose of the all day Retreat was to refocus the direction of the Network as well as determine a spend-plan for FY00. Since the Network was founded three years ago, it seems that most of the funds went into the administration and funding of proposals that advanced technology in the RF field. It was mentioned that the Network should also be a place where NAWCWD Scientists and Engineers could get together to exchange ideas and 'network.' Below is the list of topics that were covered during the Retreat.

- 1). List of issues to be discussed during the Retreat
- 2). Reiterate (Core) S&T Definition
- 3). Future Direction
- 4). Down-selecting of Proposals Process
- 5). FY00 Funding
- 6). Open Forum

1). Issues Discussed-

In order to give the most benefit to the attendees, everyone was asked to list the issues that they most wanted to discuss during the retreat. Below is that list (it should be noted that not all issues were discussed, but they are listed here as possible topics in future VTCs or Retreats): (Note: These topics are not listed in any particular order.)

- A). RF/Microwave technician talent depletion problem
- B). Basic capability work around ideas (e.g. where to go to get good circuit board manufacturers)

- C). Facility support by management
- D). RF Network involvement in SBIR
- E). Proposal funding amount / # of proposals to fund
- F). Mechanism for ideas exchange
- G). Direction of Network
- H). Proposal Down-select Process
- J). RF Website Discussion
- K). Definition of Network
- L). RF Network Operations
- M). Meetings
- N). Generation of Ideas (See also F)
- P). Direction of Proposals
- Q). How to achieve more individual participation in the Network
- R). How to get more funding for the Network
- S). How to promote teaming
- T). Joint RF Network Project
- U). Enhance Pt. Mugu's participation in the Network
- V). Refocus on Networking
- W). Marketing of Skills

2). Reiterate RF S&T Network Definition-

Next, the attendees were asked what function the RF S&T Network should provide. Listed below are the items mentioned:

- A). Internal Networking- Develop and sustain interest in RF seminars, VTCs, Web Page, and other topics of the RF S&T.
- B). External Focus- Keep sponsors informed on direction of Network (Keep ROI, Return-On-Investment, in mind).
- C). Facilities Familiarization – Conducted tours so the members of the RF Network are familiar with the facilities and capabilities at both Pt. Mugu and China Lake.
- D). People Familiarization – Ensuring that the members of the RF Community know people who are working in the different areas of RF.
- E). Dedicate more funding to 'networking.'
- F). How do we network.
- G). Corporate Awareness – Letting IPTs know the capabilities of the people that comprise the RF Network.
- H). Teaming – The Network should team together to accomplish its' goals
- J). Administration of Core S&T Funds.
- K). Setting up a future retreats to discuss some current technical problems affecting current on-going NAWCWD programs.

- L). Discuss ideas for Proposals prior to submission, using the Network as a "sounding board."
- M). The prospect of Joint Projects (Teaming, see also H).
- N). How to respond to external requests for support.
- P). Providing the RF Community with Useful Tools (e.g. Website links, Vendor info, Seminars, FAQs).
- Q). Transition of proposals to direct funding.

3). Future Direction-

The Retreat attendees were then instructed to provide ideas on how the Network could accomplish the issues listed in Section 2 above. The five main topics were:

- A). Monthly VTC Meetings
- B). Development of the RF Web Page
- C). Facilities Tours
- D). Create and maintain MS Outlook Calendar for the RF S&T Network events
- E). Establishment of Technical Seminars
- F). Future Retreats.

A). Monthly VTC Meetings- A standard time to hold the monthly VTCs was decided upon. The first Tuesday of the month from 9-11am has been adopted. A possible list of activities that the VTC should include is:

- Technical Presentations
- List of Upcoming Seminars
- Monthly Review of Web Page Highlights
- List of Personnel
- Organizational Charts (Who's Who)
- Highlights of Facilities, Available Tools
- Discussion of technical current events/problems affecting the RF Community
- Open Forum

At the next VTC, the RF S&T Network should be briefed on "Who's doing what." In other words the Structure of the Network, where and who funds the network, etc.

Action Item: Scott K. to add "Who's doing what" to the next VTC agenda.

It was also mentioned that VTC participation would increase if a member could use their desktop PC to view the monthly meetings. Also, the use of Meeting Maker in Outlook would help to 'Ping' members about the monthly VTC.

Action Item: Ron S. to look into the possibility of transmitting the monthly meetings via PC in addition to the VTC.

B). RF Web Page- Piotr Adamski has established the shell of the RF Web Page on a temporary server. He is currently working on transferring it to a permanent site as well as building up the database. A page was suggested to include the e-mail addresses of the entire RF Network.

Action Item: Piotr A., Pam O. and Marv R. will need to come up with a form to be sent to the Members for information that will be placed in the Who's Who section of the RF Network Web Page.

C). Facility Tours- In order to make the RF Community aware of the resources available at both Pt. Mugu and China Lake, Facility Tours were mentioned as a means of accomplishing that goal. There are three different resources as well as three different types of tours that could be taken. The three resources are:

- i). People
- ii). Capabilities (Hardware, Software, and Analysis)
- iii). Facilities (Special Measurements)

The three different types of tours are:

- i). Live Tour
- ii). Live Camera
- iii). Video Tape

(Note: Live Camera and Video Tape are a means whereby people who were unable to attend the provided tours could benefit from them at a later date.)

It was decided that at least one or two live tours of Pt. Mugu and China Facilities would be arranged in FY00. If resources are available, the other two types of tours will be considered. At a future VTC, attendees will be asked what facilities they would like to see.

Action Item: Scott K. to include discussion of tours in the agenda of next VTC.

D). Create & Maintain Calendar for the Year- It would be helpful if a calendar that contained all of the RF S&T Network activities could be listed so that any member could view it. Some of the activities would include VTCs, Seminars, Tours, Midyear Review, Retreats, and Brainstorming Sessions. The calendar could use MS Outlook and it would be available through the Web Page.

Action Item: West K., Pam O., Scott K., and Piotr A. to look into setting up the calendar and incorporating it into the Web Page.

E). Establishment of Technical Seminars- Technical Seminars are another way for RF S&T members to benefit from the Network. Topics would be solicited from the members at the next VTC as well as on the Web Page. These seminars could be given by members internal to the Network (similar to the Technical Presentations that have been previously given at past RF S&T VTC meetings. Also, guests external to the Network could be invited to speak at a VTC meeting.

Action Item: Scott K. to add discussion of Technical Seminars to the next VTC agenda.

F). Future Retreats- The possibility of additional retreats was discussed. These retreats would be used as brainstorming sessions to discuss solutions to current problems as they relate to technology thrusts. They could also be used to generate ideas for future joint proposals for FY01.

4). Down-selecting of Proposals Process-

The following process was agreed upon for the selection to fund FY00 RF S&T Proposals.

- A). One proposal chosen from Pt. Mugu and voted on by Pt. Mugu members only.
- B). One proposal chosen from China Lake and voted on by China Lake members only.
- C). The rest of the proposals will be selected 'at large' by the entire Voting Group.
- D). The proposals will be evaluated as follows:
 - 10 points (maximum) for Technical Merit
 - 10 points (maximum) for Transition to Direct Funding Potential
- E). The high and low scores given to each proposal will be thrown out.
- F). There will be four (4) proposals funded at \$19K apiece.

Next year, a guidance statement as well as a pre-screening process for proposals will be instituted. It will approximately start in the April-May timeframe.

5). FY00 Funding-

The RF S&T is tentatively funded for \$120K. The breakdown of the funding is shown below.

A).	Proposals	4@\$19K	\$76K
B).	Web Page		\$20K
C).	Tours	2@\$5K	\$10K
D).	Administration		<u>\$14K</u>
	Total		\$120K

6). Open Forum -

The last few minutes of the Retreat were used to discuss any general/closing thoughts that each attendee had. A listing of these thoughts are annotated below.

- A). Mentoring of talent to prevent loss of capability.
- B). How should people gain access to the Web Site, and who should it be restricted to.
- C). What is the definition of the Core S&T Thrusts
- D). How do we refocus the Network to be useful to the RF engineer
- E). Work the issue of Pt. Mugu's participation in the Network
- F). Tours are important to familiarize RF Engineers with the capabilities of NAWCWD not just China Lake or Pt. Mugu.
- G). The Network responsibility is to give Frank Markarian (the Network's sponsor) the tools that he needs to secure more funding for the RF Network.
- H). Appreciation of the dedication and energy of the Retreat participants and thankful to see that the Retreat addressed the issue of identifying the concerns of the RF S&T Network successfully.

Adjournment-

West Katzenstein adjourned the meeting at 1630. The next meeting will be at the VTC on Friday 22 Oct. 1999 to discuss the FY00 proposals.

Respectfully submitted,

Scott Kujiraoka
West Katzenstein
Pam Overfelt

For the sake of conciseness, the Action Items from the Retreat are enumerated below:

- I). **Action Item 1:** Scott K. to add "Who's doing what" to the next VTC agenda.
- II). **Action Item 2:** Ron S. to look into the possibility of transmitting the monthly meetings via PC as well as VTC.
- III). **Action Item 3:** Piotr A., Pam O. and Marv R. will need to come up with a form to be sent to the Members for information to be placed in the Who's Who section of the RF Network Web Page.
- IV). **Action Item 4:** Scott K. to include discussion of tours in the agenda of next VTC.
- V). **Action Item 5:** West K., Pam O., Scott K., and Piotr A. to look into setting up the calendar and incorporating it into the Web Page.
- VI). **Action Item 6:** Scott K. to add discussion of Technical Seminars to the next VTC agenda.

This page intentionally left blank.

INITIAL DISTRIBUTION

5 Naval Air Warfare Center, Patuxent River

Air-4.5.5.5

- J. Asvestas (1)
- J. Laska (1)
- M. Palamar (1)
- J. Stamm (1)
- S. Tabet (1)

60 Naval Air Warfare Center Weapons Division, Point Mugu

Code 4KL200E, P. McPartland (1)

Code 41K130E, K. Becker (1)

Code 411000E

- B. Berry (1)
- R. Blattel (1)
- S. Clay (1)
- L. Deshotel (1)
- J. Fisher (1)
- R. Gierut (1)
- F. Gutierrez (1)
- D. Lindemann (1)
- M. Makuch (1)
- C. Moncrief (1)
- J. Montemayor (1)
- O. Olivares (1)
- M. Schallheim (1)
- D. Sticht (1)
- J. Wallis (1)

Code 41130GE, J. Williams (1)

Code 45D000E, J. Foss (1)

Code 45T000E, B. Diehl (1)

Code 452100E, J. Hurley (1)

Code 452200E, R. Eyzaguirre (1)

Code 454000E, A. Kinghorn (1)

Code 454110E

- N. Adamyk (1)
- M. Fitz (1)
- D. Johnson (1)
- T. Yip (1)

Code 454200E, S. Hynds (1)

Code 4542200E

- A. Chen (1)
- P. Milham (1)
- T. Van Nguyen (1)

Code 454230E

- T. Anderson (1)
- C. Nguyen (1)
- D. Nguyen (1)

2 Defense Technical Information Center, Fort Belvoir

1 Northrop-Gumman, Ridgecrest, CA (J. Pettitt)

Code 454300E, H. Banks (1)

Code 454310E

D. Melton (1)

D. Rothberg (1)

M. Ryken (1)

P. Sailer (1)

Code 454320D

C. Bradley (1)

C. Dean (1)

T. Sohn (1)

Code 454400E, D. Tran (1)

Code 454510E, P. Adamski (1)

Code 454520D, L. Barak (1)

Code 47HV00E, J. Brownell (1)

Code 474500E

D. Hilliard (1)

K. Oh (1)

Code 48E000E

K. Bendot (1)

S. Nguyen (1)

Code 483300E, G. Kennedy (1)

Code 484900E, T. Huynh (1)

Code 5C0000E, A. Vines (1)

Code 5C1000E, D. Banks (1)

Code 534300E, B. Oberg (1)

Code 539400E, B. Rasnick (1)

Code 543100E

S. Kujiraoka (1)

R. Davis (1)

Code 560000E, B. Gilmer (1)

Code 763000E, I. Martinez (1)

NAWCWD TM 8304

ON-SITE DISTRIBUTION

- | | |
|--|---|
| 2 Code 400000D
K. Higgins (1)
D. Janiec (1) | 1 Code 454210D, P. TerHeun |
| 1 Code 4J4000D, E. Fujiwara | 7 Code 455500D
J. Garrett (1)
D. McCauley (1) |
| 1 Code 4KEJ00D, S. Johnson | D. Price (1) |
| 1 Code 4KK100D, J. Riggs | R. Schad (1) |
| 3 Code 4TB000D, J. Fischer | T. Smith (1) |
| 1 Code 4TL000D, Technical Library | A. Thomas (1) |
| 3 Code 4T1000D
B. Clark (1)
T. Loftus (1)
F. Markarian (1) | J. Weeks (1) |
| 1 Code 4T4100D, D. Decker | 3 Code 470000D
B. Campell (1)
A. Mickelsen (1)
S. O'Neil (1) |
| 2 Code 4T4110D
L. Johnson (1)
M. Moran (1) | 1 Code 47BE0D, D. Burdick |
| 3 Code 4T4120D
L. Desandre (1)
D. Marrs (1)
C. Yoo (1) | 1 Code 47CA31D, M. Mumford |
| 1 Code 4T42A0D, D. Harris | 1 Code 47GN00D, G. Craig |
| 1 Code 4T4220D, J. Stenger-Smith | 1 Code 47HC00D, D. Wilkerson |
| 1 Code 4T4300D, T. Boggs | 2 Code 47HH00D
R. Fowler (1)
C. Hauser (1) |
| 4 Code 4T4400D
M. Elson (1)
C. Schwartz (1)
P. Tran (1)
J. Van Wieren (1) | 1 Code 471600D, G. Hewer |
| 3 Code 45T000D
P. Bott (1)
R. Hintz (1)
W. Tanaka (1) | 1 Code 471700D, P. Bowen |
| 2 Code 452300D
M. Boyd (1)
B. Perrine (1) | 1 Code 472000D, J. McCalester |
| 10 Code 452310D
M. Anderson (1)
P. DeRuiter (1)
M. Frisbee (1)
W. Katzenstein (1)
K. Koch (1)
B. May (1)
J. Otto (1)
G. Roush (1)
R. Schramm (1)
H. Wang (1) | 1 Code 472A00D, M. Stringham |
| 3 Code 452320D
D. DeKruiger (1)
O. McNiel (1)
D. Roth (1) | 1 Code 472100D, A. Hickle |
| 1 Code 452350D, F. Armogida | 1 Code 472400D, R. Perrine |
| 2 Code 4541200D
Collier (1)
C. Gillespie (1) | 4 Code 473100D
R. Chew (1)
J. Kerns (1)
J. Piri (1)
R. Skatvold (1) |
| | 4 Code 473200D
M. Afendykiw (1)
S. Ghaleb (1)
C. Kidner (1)
F. Schiavone (1)
T. Williams (1) |
| | 5 Code 473300D
N. Bling (1)
E. Kandell (1)
D. Miller (1)
D. Paolino (1)
F. Schiefen (1) |
| | 2 Code 473400D
M. Neel (1)
S. Rogala (1) |
| | 1 Code 474100D, D. Garcia |
| | 1 Code 474200D, J. Gustafson |
| | 1 Code 476000D, C. Porter |
| | 1 Code 478C00D, D. Thompson |
| | 1 Code 535200D, W. Swinford |