

REPORT DOCUMENTATION PAGE

AFRL-SR-BL-TR-00-

88

Public reporting burden for this collection of information is estimated to average 1 hour per response including gathering and maintaining the data needed, and completing and reviewing the collection of information, including suggestions for reducing this burden, to Washington Headquarters Collection of Information, including suggestions for reducing this burden, to Washington Headquarters Collection of Information, including suggestions for reducing this burden, to Washington Headquarters Davis Highway, Suite 1204, Arlington, VA 22202-4302, and to the Office of Management and Budget, Paperwork Project (0704-0188).

0592

g data sources, r aspect of this 1215 Jefferson 20503.

1. AGENCY USE ONLY (Leave blank)		2. REPORT DATE		3. REPORT TYPE AND DATES COVERED Final - 1 March 1995 - 31 August 1998	
4. TITLE AND SUBTITLE FUNDAMENTAL MODEL FOR PREDICTING LIFETIME PERFORMANCE OF HIGH PERFORMANCE POLYMERIC MATERIALS				5. FUNDING NUMBERS F49620-95-1-0216	
6. AUTHOR(S) Dr. James M. Carruthers					
7. PERFORMING ORGANIZATION NAME(S) AND ADDRESS(ES) Purdue University West Lafayette, IN 47907-1283				8. PERFORMING ORGANIZATION REPORT NUMBER	
9. SPONSORING/MONITORING AGENCY NAME(S) AND ADDRESS(ES) AFOSR/NL 801 North Randolph Street, Room 732 Arlington, VA 22203-1977				10. SPONSORING/MONITORING AGENCY REPORT NUMBER	
11. SUPPLEMENTARY NOTES					
12a. DISTRIBUTION AVAILABILITY STATEMENT APPROVED FOR PUBLIC RELEASE: DISTRIBUTION UNLIMITED				12b. DISTRIBUTION CODE	
13. ABSTRACT (Maximum 200 words) 1H, 2H, 3C and 15N solid state NMR techniques were used to investigate high performance polyimide resins. Solid state 15N NMR appears to be the most sensitive technique to the chemical reactions involved in the cure and degradation of polyimide resins. The AFR700 cure reaction pathways are very similar to amine cured bismaleimide chemistry and appears to be much more complex than PMR type systems. The AFR backbone is relatively robust under hydrolytic conditions. The AFR700 end-groups in the cured polymer are not stable under these conditions. A large volume MAS probe has been built for operation at 9.4 Tesla. The probe will spin a 10 mm zirconia rotar at 4 kHz. The mechanical design is easily scaled to even larger systems. This 10 mm probe requires only one-fourth the time to acquire the same signal-to-noise ratio as a commercial 5mm probe.					
14. SUBJECT TERMS POLYMERIC, HIGH-PERFORMANCE				15. NUMBER OF PAGES 39	
				16. PRICE CODE	
17. SECURITY CLASSIFICATION OF REPORT Unclas		18. SECURITY CLASSIFICATION OF THIS PAGE Unclas		19. SECURITY CLASSIFICATION OF ABSTRACT Unclas	
20. LIMITATION OF ABSTRACT					

20001109 005

Final Technical Report
on AFOSR Grant No. F4960-95-0216

**Fundamental Models for Predicting Lifetime Performance
of High Performance Polymeric Materials**

P.I. - James M. Caruthers
School of Chemical Engineering
Purdue University
West Lafayette, IN 47907-1283

Table of Contents

Abstract		ii
1.0	Introduction	1
1.1	Solid State NMR Studies of Polyimide Resins	1
1.2	Development of a Large Volume MAS NMR Probe	3
2.0	Summary of Results and Discussion	4
2.1	Solid State NMR Studies of Polyimide Resins	4
2.2	Development of a Large Volume MAS NMR Probe	7
3.0	Conclusions	13
3.1	Solid State NMR Studies of Polyimide Resins	13
3.2	Development of a Large Volume MAS NMR Probe	13
References		14
Appendix A	First Year Progress Report	16
Appendix B	Second Year Progress Report	20
Appendix C	Third Year Progress Report	23
Appendix D	Technical Drawings of MAS Probe	28

Abstract

The principle objective of this research program has been to develop rational methods for prediction of the lifetime performance of high temperature polymer matrix composites. The methods used to achieve this goal have focused on using solid state NMR techniques to clearly define and understand the actual network structure found in high temperature polyimides and to investigate how this structure is affected by environmental factors such as heat and humidity. A major finding of this project is that the final network structure of AFR700-type polymers is very similar to that observed for amine cured bismaleimide oligomers. This finding is significantly different from what had been previously reported in the literature for this type of polymer and for what has been recently reported for PMR type polymers.

A second goal of the project has been to develop a large-volume MAS (magic angle spinning) probe to perform natural abundance ^{15}N NMR experiments on high temperature polyimide type polymers. The purpose of this probe is to minimize or eliminate the requirement for isotopic enrichment of these high temperature polymers, which is extremely expensive and impractical for investigating typical formulations and components. This probe has been constructed for use at 9.4 Tesla and will spin a loaded 10 mm zirconia rotor at 4 kHz for several days with no signs of wear. The probe has demonstrated a factor of two improvement in signal to noise using natural abundance glycine.

1.0 Introduction

The primary objective of the Purdue effort is to begin development of physically realistic models for predicting the lifetime performance of the polymer matrix resin used in high temperature structural composites. The development of physically realistic models requires a detailed knowledge and understanding of the basic network structure and the processes involved in its formation and degradation. The main effort of this research has been directed toward using solid state NMR to investigate the cure and degradation of these high temperature polyimide resins and to develop better methods for this purpose. As part of our efforts, we provide solid state NMR support for research at the Air Force Research Laboratories - Wright Patterson (Dr. David Curliss) and for research at Prairie View A&M University (Dr. Paul Biney - PI).

This final report contains a limited introduction and background information on recent solid state NMR studies of polyimide resins and the development of large volume MAS probes for use at high magnetic fields. A summary of the important results from this investigation is provided in the next section, followed by conclusions and suggestions for further work. The first three annual reports are included in appendixes A - C for reference and detailed technical drawings of critical parts of the large volume probe are provided in appendix D.

1.1 Solid State NMR Studies of Polyimide Resins

In recent years, a variety of polyimides have been synthesized with the aim of improving certain physical properties.^{1,2} The successful synthesis of a polyimide depends on the choice of monomer components as well as the specific synthetic method. Thus, the reaction mechanisms and the final network structure depend significantly upon the specific components and the cure conditions used. Norbornene end-capped polyimide resins, which include PRM-15 and AFR700, are widely used in high temperature applications because they are relatively easy to process and exhibit good thermo-oxidative stability. However, mechanistic information on these particular systems has been somewhat limited due to their intractable physical properties. Considerable information about the chemistry and kinetics of polyimide formation and degradation have been uncovered in recent years, however, there are still many issues that remain unresolved. A fundamental understanding of all aspects of the cure and degradation processes has been lacking due to the complexity of the problem. In order to address these issues, knowledge of the specific molecular network structure is absolutely necessary as a basis for understanding the observed physical properties and the degradation mechanisms.¹⁻⁴

Meador et al.⁵ has used specifically labeled PMR-15 monomers and solid-state ¹³C NMR to address the cross-link structure in this system under normal cure conditions. They observed that the main cross-link mechanism is polymerization of the double bond of the nadic end cap. They believed that only about 15% of the cross-linked products could result from a reverse Diels-Alder mechanism in this system. They also found evidence that a small amount (< 5%) of the methylene group in MDA participates in the cross-link structure. However, they suggest that all of the cross-link products could have come from a biradical mechanism. It is interesting to note that even though radical mechanisms are prevalent in imide chemistry and several stable radical species have been observed,⁶ NMR remains a very useful and powerful tool in the investigation of these systems. While reactive amine groups may play only a minor role in the PMR-15 system due to the stoichiometry of the formulation, they will have considerably more importance in the cure and degradation of the AFR700 system.

Several recent papers have focused on the effects of hydrolytic degradation in polyimide systems.⁷⁻⁹ Polyimides have relatively high permeabilities to water vapor due in part to the polar imide group. More importantly, absorbed water affects the physical properties, such as mechanical and dielectric properties, as well as the long-term stability of the polymer. Water is believed to play a major role in the thermal degradation of PI's at high temperatures.⁸

The importance of thermo-oxidative degradation and stability is reflected by numerous recent publications and reviews.¹⁰⁻¹¹ General correlations can be made between PI stability and the primary network structure, the effects of reactive end group terminations, and environmental factors which can enhance degradation mechanisms. Quite often the secondary structure of the polymer may be the determining factor in the polymer stability by limiting the diffusion of reactive species or by generating new cross-link points or even by reorganizing the molecular backbone structure upon oxidation. With regard to primary structure, the stability of a polyimide system appears to depend more on the diamine structure than on the dianhydride structure. The diamine structure is believed to have higher localized electron density and thus be a more likely site for oxidative degradation. It has been observed that during the thermolysis of polyimides chain cleavage originates in the imide ring, while oxidative cross-linking originates at unreacted amine fragments.¹⁰

Oxidative degradation of the PMR-15 system has recently been examined in some detail by Meador et al.¹¹ using ¹³C labeled nadic ester and MDA. This study provides the first direct evidence for the type of degradation occurring at the nadic end-cap and shows that the end-cap is severely oxidized within several hours in air. The methylene bridge of MDA is also readily oxidized first to a ketone and then to an ester or acid. These results were correlated with weight

loss studies, which indicate that the most rapid weight loss appears to come from oxidation of the nadic end-cap. A particularly interesting result was that in the absence of air, the NMR as well as FTIR spectra show no change for up to 120 hours at temperature. As expected, spectra of the oxidized material are quite complex, even with the specific ^{13}C labels, and absolute peak assignments remain to be made.

In summary, tremendous advances have been made recently in understanding the chemical and physical processes that take place during the cure and degradation of polyimides. However, the evidence and the understanding are incomplete for many systems. As discussed below, the cure chemistry of the AFR700 system appears to be much more complex than either the MPBM/MDA¹²⁻¹³ or PMR-15^{5,11} systems. Clearly, many of the chemical processes, both during cure and degradation, occur at the nitrogen in these systems. Therefore, it is not surprising that ^{15}N solid state NMR has provided valuable information to understand these processes.

1.2 Development of a Large Volume MAS NMR Probe

Solid state ^{15}N NMR methods are particularly useful in investigating the cure and degradation mechanisms of nitrogen-containing polymers, since the nitrogen atom is directly involved in many of these reactions.¹⁴ The ^{15}N isotope is a spin 1/2 nucleus with a rather large chemical shift range and relatively small chemical shift anisotropy which yields simple, well resolved spectra in most cases. The nitrogen chemical shift is quite sensitive to its local chemical environment, which permits observation of the different nitrogen-containing functional groups present in the sample. However, the ^{15}N isotope is only about 0.3% naturally abundant and has a low gyromagnetic ratio which results in relatively poor sensitivity. Several days to weeks are required to achieve acceptable signal-to-noise, S / N in an ^{15}N NMR experiment with approximately 100 milligrams of polymer at natural abundance. There are techniques for improving this situation however, since the signal is directly proportional to the number of nuclei being observed. Furthermore, the signal to noise ratio increases as the square root of the number of times the signal is acquired.

Two methods are typically employed to improve the signal/noise ratio.¹⁵⁻¹⁸ Increase the number of nitrogen-15 atoms in a fixed sample size via isotopic enrichment, or increase the sample volume being observed and thus the total number of ^{15}N nuclei. Since very few compounds of interest are commercially available with specific ^{15}N labeling, isotopic enrichment is almost always a very

time consuming and expensive process, requiring custom syntheses with costs of \$150 to over \$1000 per gram. A sample with 100% isotopic labeling reduces the NMR experiment time to several hours, which allows one to evaluate a variety of parameters during sample cure and degradation. Although the information obtained with isotopic labeling has proven quite valuable, the costs can become prohibitive, especially when one wishes to examine real world samples.

The logical alternative is to increase the signal by increasing the sample volume.^{17, 18} Although there are some practical limits on the actual sample size that can be placed into the bore of a superconducting magnet, one should be able to obtain a timesavings comparable to that obtained with isotopic enrichment. A large sample volume magic angle spinning, MAS, probe has been constructed in this laboratory and will be described in the following sections. The development of this large volume probe will provide information on many different systems without resorting to isotopic enrichment - saving a great deal of time and money.

2.0 Summary of Results and Discussion

2.1 Solid State NMR Studies of Polyimide Resins

Observations by ^{15}N NMR indicate that the cure chemistry of AFR700B type resins may be similar to that observed for BMI / MDA systems.^{12, 13} The two stage cure of an ^{15}N labeled AFR700 oligomer ($n=2$) is shown in Figure 1. In the as-pressed state, the backbone nitrogen resonances occur at 140 ppm, and the succinimide and amide resonances occur at 160 and 120 ppm, respectively. After the cure and post-cure stage, we see that the succinimide resonance at point A has decreased substantially and that a relatively large amide or amic acid resonance has formed at approximately 100 ppm (point B). An amine resonance at 25 ppm (point C) is also formed. Although the data shown here is not quantitative, it does show that the cure mechanisms of the AFR700 system may be similar to those observed for the BMI system. At first, this may appear somewhat surprising in light of the ^{13}C NMR evidence on PMR-15 reported by Meador,⁵ however, the one important difference is the existence of the reactive amine group in the AFR700 formulation.

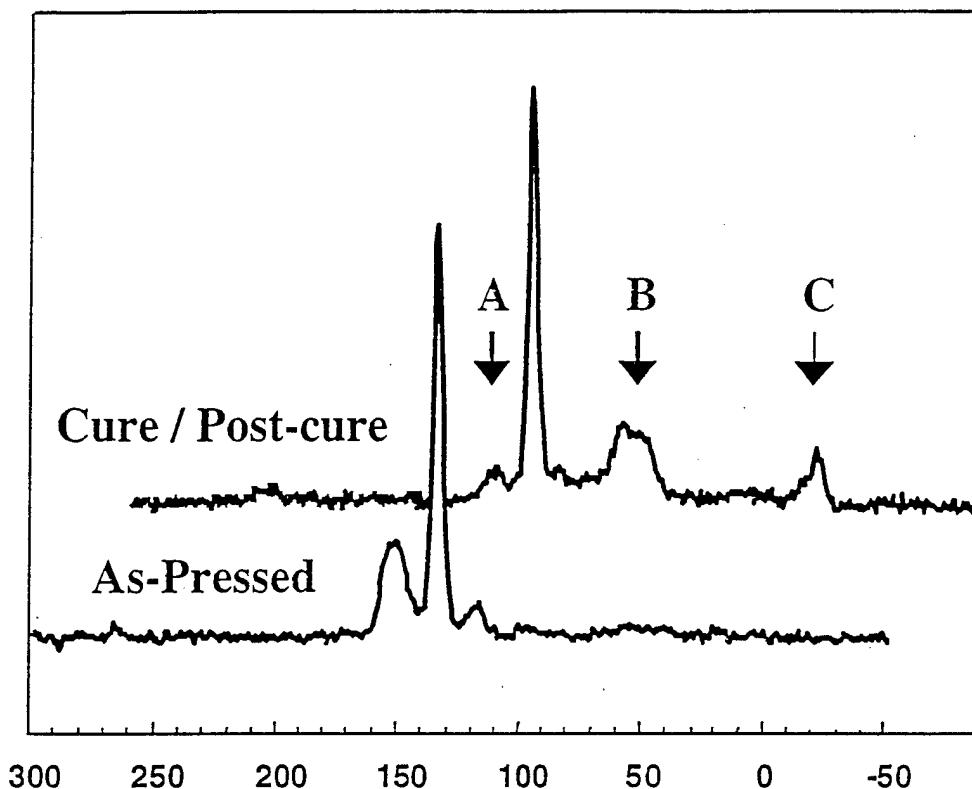

Figure 1. Solid state ^{15}N CPMAS NMR of a cured AFR700B oligomer ($n=2$).

The hydrolytic degradation of the AFR700 oligomer,¹³ described in the cure section above, indicates that the end-caps are quite susceptible to degradation. The hydrolytic degradation of two AFR700 resins is shown in Figure 2 along with the conditions for water saturation. In Figure 2A, the main resonance at 140 ppm is due to the fully labeled backbone nitrogens. These spectra show that the backbone appears to be relatively unaffected by these degradation conditions. The arrow in Figure 2A points to an amide or amic acid, which is formed within the first 2 hours and represents less than 5% of the total nitrogen. The spectra in Figure 2B are for an AFR700B oligomer ($n=2$) in which only the end-group nitrogens are labeled. The arrows in these spectra clearly show a decrease in the succinimide group at 160 ppm and an increase in the amic acid region at 120 – 100 ppm. Surprisingly, the amine resonance does not show significant changes under these conditions. Absolute identification of the resonance at 120 ppm remains unresolved. Furthermore, it may be that the amine resonance remains relatively unchanged due to the fact that it is in equilibrium with some other component. Finally, this data does establish which degradation mechanisms may be important, but is preliminary and is not quantitative. Quantitative data must be collected in order to establish trends or to correlate the data with other physical properties.

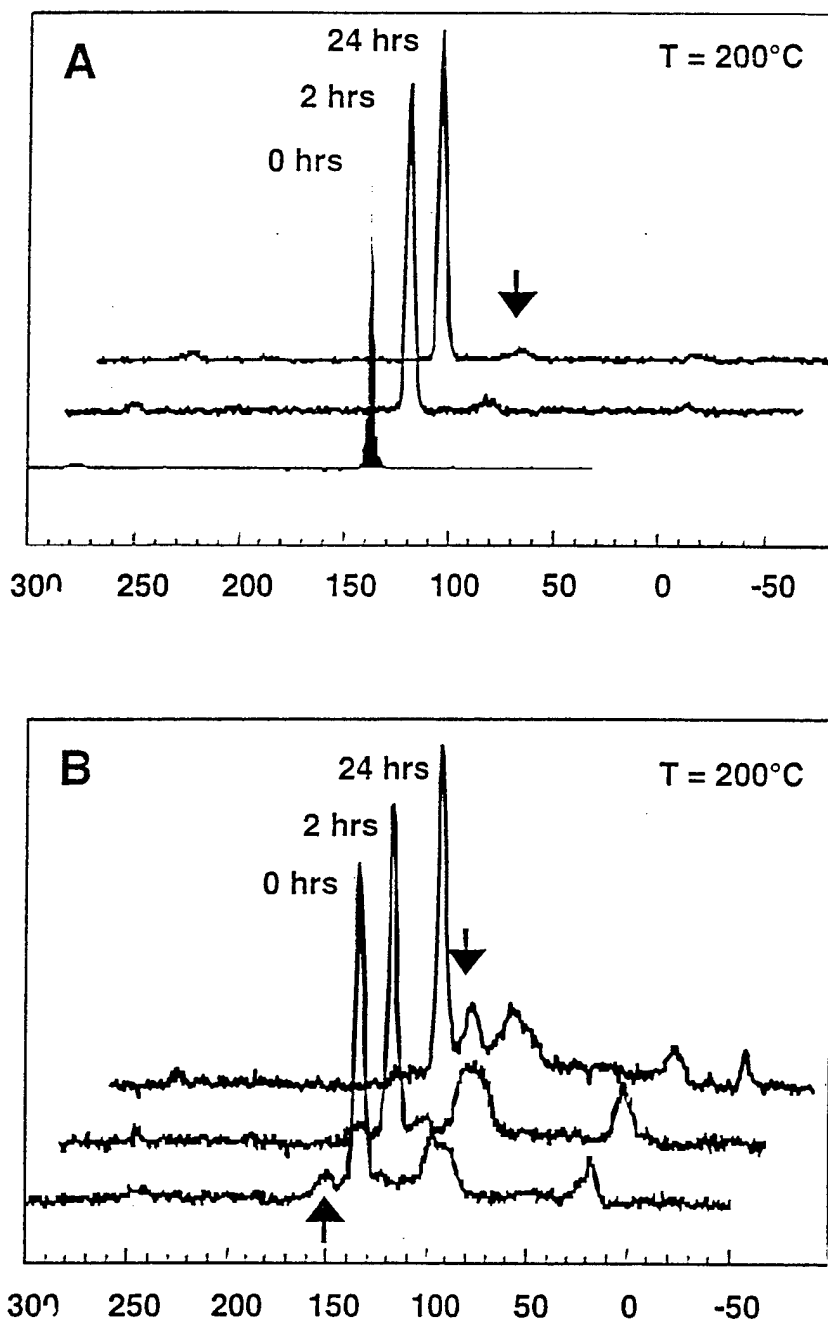

Figure 2. Solid-state ^{15}N CPMAS NMR spectra of hydrolytic degradation of fully labeled AFR700B (A) and end group labeled AFR700B $n=2$ oligomer (B).

2.2 Development of a Large Volume MAS NMR Probe

As part of the No-Cost Extension following the Third Year Report, the probe was completely redesigned and rebuilt. This was largely due to the observed performance limitations discussed in the Third Year Report. The original spinning assembly was scaled up from a design published by Doty.^{19, 20} This design is not particularly efficient for spinning rotors with large volume and mass. The new design is similar to that described by Pines, et al.²¹ but utilizes a Bernoulli air-bearing and a Beams-type^{22, 23} turbine on each end of the rotor. Technical drawings for this design are included in Appendix D. This type of drive/bearing assembly coupled with the double bearing supporting the body of the rotor as used by Doty and Pines provides extremely stable high speed spinning of this large volume/mass rotor. Indeed, the observed spin rate stability appears to be better than 0.25% over several hours. In addition, the maximum spin rate for a 10 mm diameter rotor increased from 1 kHz to 4 kHz. This is a significant improvement in the spin rate performance and is near the physical limit for the high strength zirconia rotor. The spin rate performance should now be sufficient for most ¹⁵N spectra.

The new design required extensive modifications to the existing probe and required several new components to be machined. Many of these modifications were made in-house, while some of the critical precision components were machined by Precision Engineering.²⁴ The new housing was machined from Delrin[®]. The stator is shaped like a spool and the ends make a press fit in the housing. This provides a larger area for mounting single or possibly multiple coils. The stator is machined from Macor[®] machinable glass ceramic or a boron nitride ceramic and is somewhat fragile. Thus, the housing is expanded slightly by heating with hot water before inserting the stator. At room temperature, the stator and housing provide an air tight seal for the main bearing air. The housing endcaps transfer the drive gas to the turbine and provides another air bearing at each end of the rotor. These endcaps are sealed to the housing with o-rings to reduce drive air loss. The large gas exhaust holes for the drive and bearing air are critical to the spin rate performance. New turbine rotor endcaps were machined from Vespel[®]. Several flute designs were investigated and the reader is referred to a more detailed discussion by Beams.^{22, 23} The length of the rotor endcaps also affects the spin rate performance. This length was adjusted so that there was approximately 0.010 inches for the rotor to move along the axis of rotation, as the rotor essentially floats inside the stator when spinning. These modifications were tested in the bench spinner prior to incorporation into the probe body.

Once the mechanical system was complete, the RF system was also integrated into the probe. This required a new circuit board for a single tuned, broadband circuit optimized for operation at 40 MHz. A new observe coil was made from 6 turns of high purity, gold-coated copper ribbon and wound on the outside of the stator. The coil dimensions were approximately 13.7 mm diameter by 7.7 mm in length. This results in an inductance of approximately 490 nH. The coil was tuned and matched with parallel / series high voltage variable capacitors. Mounting contacts for these high voltage capacitors were made from 0.3 mm thick high purity copper foil and designed to reduce the self-inductance of the capacitors according to the manufacturers directions. The completed circuit was optimized for ^{15}N operation with a tuning range of approximately 50 MHz.

The completed probe assembly was tested for mechanical and RF operations. The probe housing was set mechanically to approximately 54 degrees from vertical and the probe will spin a well balanced, fully loaded rotor up to 4 kHz. A 5 mm tube of CDCl_3 inserted into the 10 mm zirconia rotor was used for shimming during the initial installation and setup of the probe. Shimming is the term used for optimizing the B_0 field homogeneity over the sample volume. This sample was shimmed to a full width at half maximum (FWHM) of 2.4 Hz with a nearly ideal Lorentzian line-shape. At 0.55% and 0.11% of full intensity, the measured line-widths were 47.6 Hz and 138 Hz compared to the ideal Lorentzian line-widths of 45.9 Hz and 102 Hz. This deuterium, ^2H , line-shape is shown in Figure 3. The ^2H 90-degree pulse width was calibrated at relatively low power on this sample, because the high power ^2H amplifier was not available. The 90-degree pulse width was approximately 15 microseconds, us, under these conditions and the calibration is shown in Figure 4.

In order to set the sample rotation axis precisely at the magic angle, the probe is required to tune to the resonant frequency of ^{79}Br at 100.4 MHz.²⁵ Although alternative quadrupolar nuclei have been suggested for use in adjusting the magic angle, the ^{79}Br nucleus of potassium bromide, KBr , has provided the best sensitivity. The resonant frequency was adjusted by soldering a second coil in parallel with the sample coil to reduce the overall inductance and increase the resonant frequency. A rotor was packed with KBr and spun at 4 kHz. The ^{79}Br centerline was set on resonance and the angle was carefully adjusted to observe the most rotational echoes in the free induction decay, FID. More than 40 rotational echoes were observed for longer than 8 milliseconds, ms. This observation indicates that the rotation axis is within ± 0.1 degree of the magic angle and is similar to the performance observed for a commercial 5 mm MAS probe.

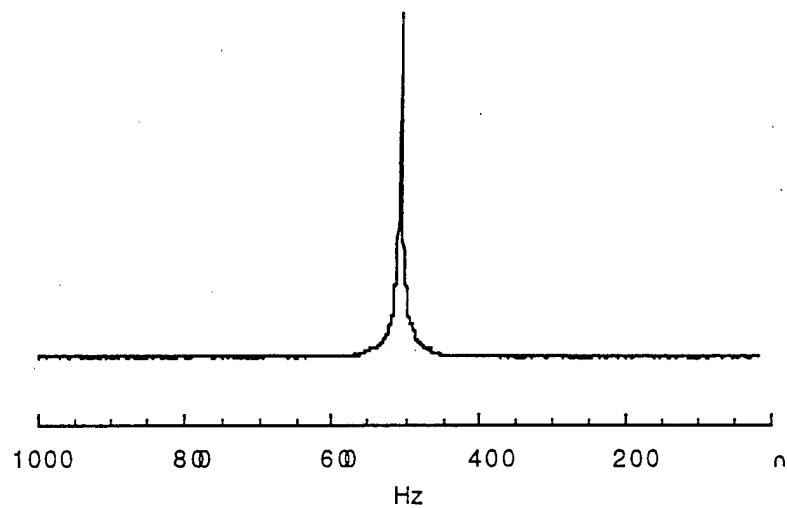

Figure 3. 10 mm MAS ^2H line-shape after shimming the probe as described in the text.

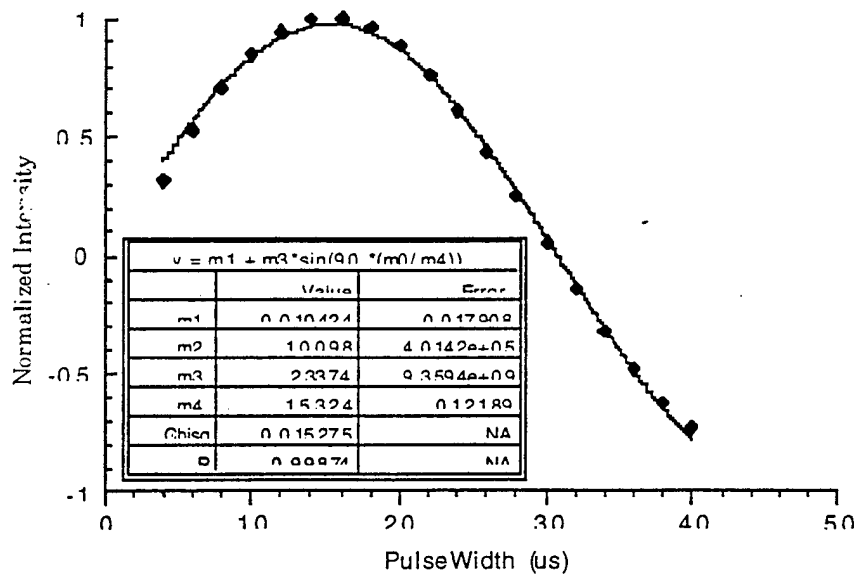

Figure 4. 10 mm MAS ^2H Pulse Width Calibration

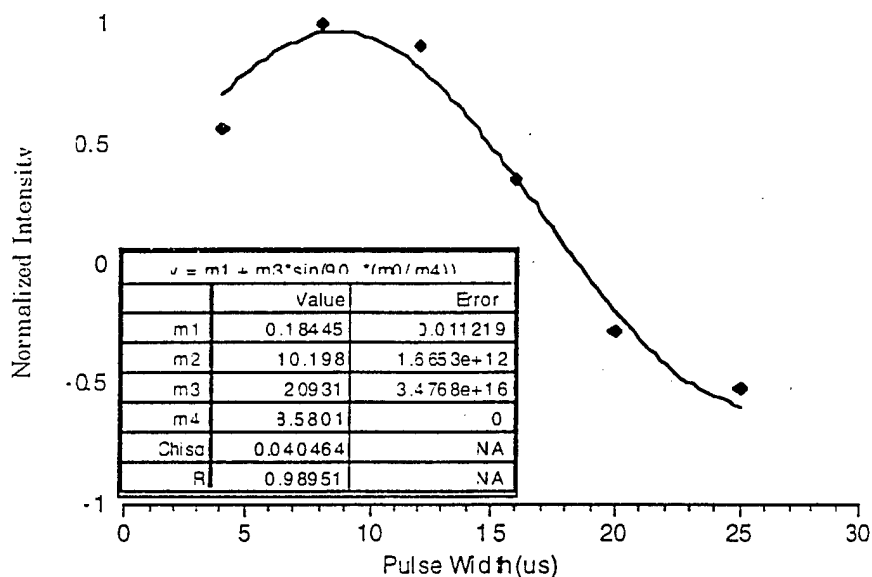

Figure 5. 10 mm MAS ^{15}N Pulse Width Calibration

After shimming and setting the magic angle, the probe was tested at ^{15}N frequency. All tests will be compared to the performance of a commercial 5 mm MAS probe. Conditions for these tests will be identical, as much as possible, except for the variable under investigation. A sample of approximately 20% ^{15}N labeled glycine in natural abundance glycine was prepared. This sample was used to measure the ^{15}N 90-degree pulse width calibration in order to reduce the overall time for the measurement. The 10 mm probe built for this investigation produced a 90-degree pulse width of 8.5 us with approximately 250 watts rf power, which corresponds to a rf field strength of approximately 30 kHz. This is much less than the 90-degree pulse width at ^2H frequency and indicates that the probe is indeed optimized for operation at ^{15}N frequency. Furthermore, this pulse width is only slightly longer than that observed for the 5 mm commercial probe of 5.2 us with similar power, which corresponds to a rf field strength of 48 kHz. The field strength of either probe is sufficient for testing and the 90-degree pulse width of either probe may be reduced significantly by increasing the available rf power. This option is not possible with the current instrument, so these pulse widths were used in all further experiments.

The T_1 relaxation of the nitrogen nucleus can be very long, especially in a crystalline sample. An attempt to measure the nitrogen T_1 relaxation time in

natural abundance glycine using a cross polarization technique in the 5 mm MAS probe resulted in a perfectly exponential decay of only 0.25 seconds. This is most likely due to the large negative NOE of the nitrogen nucleus and the short 10 second pulse delay used in the cross polarization experiment. The actual T1 was estimated to be approximately 60 seconds by running several experiments with different pulse delays. Therefore, a pulse delay of 300 seconds was used for the remaining experiments. To illustrate the importance of T1 in quantitative measurements, two single pulse experiments were performed using the 90-degree pulse width for each probe and only a 5 second pulse delay. Nearly twenty thousand pulses were acquired and the absolute signal intensity was the same for each probe, even though the 10 mm probe contained more than 8 times the amount of sample. The signal-to-noise ratio in the 10 mm probe, on the other hand, was nearly double that of the 5 mm probe. This observation is the result of saturation. However, when the 300 second pulse delay was used on these samples, the absolute signal intensity as well as the signal-to-noise ratio in the 10 mm probe was more than double that in the 5 mm probe. This result means that 4 times fewer scans, and thus one-fourth of the time, are required for the 10 mm probe to achieve the same signal-to-noise as the 5 mm probe. These results are illustrated in Figure 6. Both spectra were obtained under identical conditions: 50 kHz sweep width, 512 scans, 300 second pulse delay, 1024 complex data points, and identical gain values. Although these results are significant, the increase in the signal-to-noise ratio for the 10 mm probe is somewhat less than expected, based on the total amount of sample. This is most likely due to the relatively short sample coil in the 10 mm probe. Recall that it is only about 7.7 mm in length, while the sample rotor is nearly 18 mm in length, which means that more than half of the sample lies outside the sample coil. Since the rf field strength falls off rapidly outside of a solenoid coil, it is not surprising then that observed signal-to-noise has only increased by a factor of two. Although this project has ended, the probe remains a vital part of these investigations and modifications are in progress to improve its performance even further.

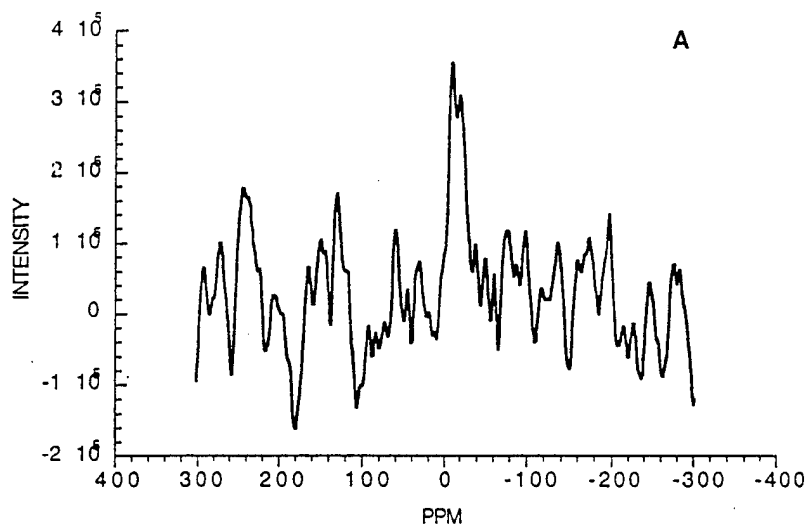
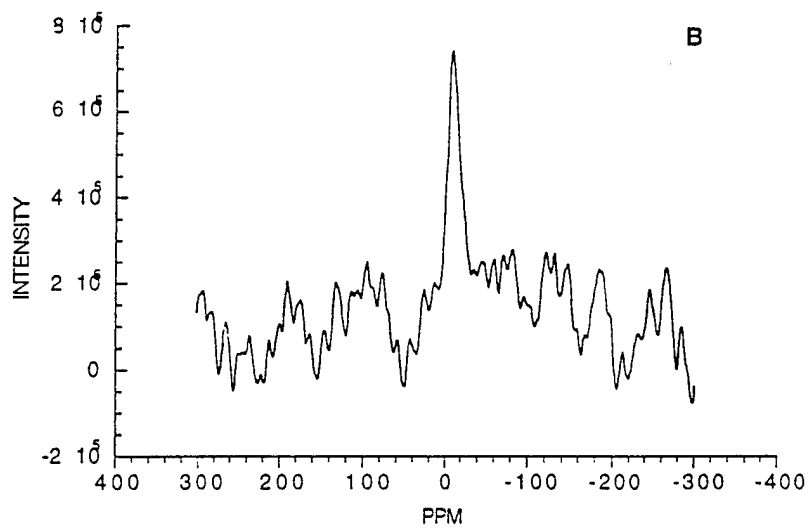

Figure 6. ^{15}N Single pulse NMR spectra of natural abundance glycine from (A) 5 mm MAS probe and (B) 10 mm MAS probe

3.0 Conclusions

3.1 Solid State NMR Studies of Polyimide Resins

^1H , ^2H , ^{13}C , and ^{15}N solid state NMR techniques were used to investigate high performance polyimide resins.

Solid State ^{15}N NMR appears to be the most sensitive technique to the chemical reactions involved in the cure and degradation of polyimide resins.

The AFR700 cure reaction pathways are very similar to amine cured bismaleimide chemistry and appears to be much more complex than PMR type systems.

The AFR700 backbone is relatively robust under hydrolytic conditions.

The AFR700 end-groups in the cured polymer are not stable under these conditions.

3.2 Development of a Large Volume MAS NMR Probe

A large volume MAS probe has been built for operation at 9.4 Tesla.

The probe will spin a 10 mm zirconia rotor at 4 kHz.

The mechanical design is easily scaled to even larger systems.

This 10 mm probe requires only one-fourth the time to acquire the same signal-to-noise ratio as a commercial 5 mm probe.

References

1. "Polyimides," D. Wilson, H. D. Stenzenberger, P. M. Hergenrother, eds., Chapman and Hall, New York, 1990.
2. "Polyimides: Fundamentals and Applications," M. K. Ghosh and K. L. Mittal, eds., Marcel Dekker, Inc., New York, 1996.
3. T. Takekoshi in "Polyimides: Fundamentals and Applications," M. K. Ghosh and K. L. Mittal, eds., Marcel Dekker, Inc., New York, 1996.
4. J. M. Sonnett and T. P. Gannett in "Polyimides: Fundamentals and Applications," M. K. Ghosh and K. L. Mittal, eds., Marcel Dekker, Inc., New York, 1996.
5. Meador, M. B., Johnston, J. C., Cavano, P. J., *Macromolecules*, **1997**, 30, 515.
6. Ahn, M. K., Stringfellow, T., Fasano, M., Bowles, K., Meador, M. A., *J. Polym. Sci., Part B*, **1993**, 31, 831.
7. Xiang, Z. D., Jones, F. R., *Composites Sci. and Tech.*, **1997**, 57, 451.
8. K. Okamoto in "Polyimides: Fundamentals and Applications," M. K. Ghosh and K. L. Mittal, eds., Marcel Dekker, Inc., New York, 1996.
9. Paplham, W. P., Brown, R. A., Salin, I. M., Seferis, J. C., *J. Appl. Polym. Sci.*, **1995**, 57, 133.
10. J. A. Cella in "Polyimides: Fundamentals and Applications," M. K. Ghosh and K. L. Mittal, eds., Marcel Dekker, Inc., New York, 1996.
11. Meador, M. B., Johnston, J. C., Cavano, P. J., Frimer, A. A., *Macromolecules*, **1997**, 30, 3215.
12. Curliss, D. B., Cowans, B. A., Caruthers, J. M., *Macromolecules*, **1998**, 31(20), 6776.
13. Curliss, D. B., Cowans, B. A., presented at the 40th Rocky Mountain Analytical Conference, Denver, CO, July 26th 1998.
14. Murphy, P. D., Di Pietro, R. A., Lund, C. J., Weber, W. D., *Macromolecules*, **1994**, 27, 279.
15. "Experimental Pulse NMR: A Nuts and Bolts Approach," E. Fukushima, S. B. W. Roeder, Addison-Wesley Publishing Co., Reading, Massachusetts, 1981.

16. "Biomedical Magnetic Resonance Technology," C-N Chen, D. I. Hoult, IOP Publishing Ltd., New York, New York, 1989.
17. Pugmire, R. J., Jiang, Y. J., Solum, M. S., Grant, D. M., *Bull. Magn. Reson.*, **1989**, 144.
18. Zhang, M., Maciel, G. E., *J. Magn. Reson.*, **1989**, 85, 156.
19. Doty, F. D., Ellis, P. D., *Rev. Sci. Instrum.*, **1981**, 52, 1868.
20. Doty, F. D., Inners, R. R., Ellis, P. D., *J. Magn. Reson.*, **1981**, 43, 399.
21. Eckman, R., Alla, M., Pines, A., *J. Magn. Reson.*, **1980**, 41, 440.
22. Beams, J. W., Pickels, E. G., *Rev. Sci. Inst.*, **1935**, 6, 299.
23. Beams, J. W., *J. Appl. Phys.*, **1937**, 8, 795.
24. Precision Engineering, Lafayette, Indiana, 47905.
25. Frye, J. S., Maciel, G. E., *J. Magn. Reson.*, **1982**, 48, 125.

Appendix A

First Year Progress Report

Fundamental Models for Predicting Lifetime Performance of High Performance Polymeric Material

J.M. Caruthers
School of Chemical Engineering
Purdue University
West Lafayette, IN 47907-1283

The primary objective of the Purdue effort is to develop and validate physically realistic models for predicting the lifetime performance of polymer matrix resins used in high temperature structural composites. Funding for this program arrived in March 1995, and this report describes the research that has been performed during the initial 6 months of the project. The primary activity has been to use ^{15}N solid state NMR to study the state of cure and hydrolytic degradation of polyimide polymers, where this work was undertaken in collaboration with Dr. David Curliss of the Materials Laboratory at WPAFB. A summary of our preliminary findings is given below.

Solid State NMR Studies of AFR Polyimide Resins

The solid state NMR spectra of ^{15}N labeled AFR700B was examined in the fully imidized, as cured, and post cured states. All spectra show a large imide peak as the major component, while post-cured sample shows small amount of amide nitrogen as well. Because of the large number of imide nitrogens in the backbone, there was a need to increase the sensitivity of endcap nitrogens to backbone nitrogens, since it is postulated that the imide groups in the endcaps may be particularly sensitive to hydrolytic degradation. The use of ^{15}N labeled AFR700II (n=2) oligomer should improve sensitivity of the ^{15}N spectra to reactions occurring at endcaps. Spectra of the imidized AFR700II show a large imide resonance as well as evidence for succinimide, secondary and tertiary amides and secondary amines. In the fully cured material, the spectra show only the imide resonance, however, spectra of the post-cured material shows a large imide resonance as well as a small amount of amide nitrogen. Preliminary investigation using triple resonance probe with ^1H decoupling was initiated in an attempt to improve ^{15}N NMR spectra of AFR resins.

^{13}C CPMAS NMR was investigated as a tool to study the degradation of unlabeled AFR700B, since unlabeled materials are much easier to obtain and far less expensive than isotopically enriched materials. The optimum cross polarization parameters were determined for an unreacted, a control and degraded samples. Although spectra are broad, resonances for carbonyl and aromatic carbons can be distinguished. AFR700B oligomer (n=2) made with

^{13}C labeled norbornene endcaps was prepared to examine what reactions the endcaps undergo during cure and post-cure conditions. ^{13}C CPMAS spectra of powder samples imidized for 12 hrs at 100 °C show a large ^{13}C resonance due to the labeled c2 carbon at approximately 50 ppm, and also show resonances associated with the aromatic carbon backbone. However, samples post-cured for 1 hr at 400 °C under N_2 and for 8 hrs at 400 °C also under N_2 show no evidence of the ^{13}C labeled carbon at 50 ppm. The labeled carbon may have become aromatic or olefinic in nature, resulting in resonances overlapping with the natural abundance aromatic resonances. However, there also appears to be an overall loss in signal intensity, which cannot be accounted for at this time. Because of the large chemical shift anisotropy of the aromatic carbons and the strong ^{19}F - ^{13}C dipole coupling, a relatively broad featureless spectrum is observed. In summary, ^{13}C CPMAS provides poor spectra for determining the extent of cure and/or degradation in AFR700B type materials.

^1H NMR was used to probe the amount of water in AFR700B samples following various hydrothermal treatments. Proton spectra show a broad single resonance for the polymer superimposed on a sharp resonance for the water. Although the spectra are sensitive to the amount of water present, the ^1H solid state NMR does not appear to be sensitive to the material degradation. Subsequently, ^2H NMR was used to follow degradation of AFR700B using D_2O . Samples saturated at room temperature show only a narrow resonance corresponding to unbound D_2O . A saturated sample was dried under vacuum at 110 C for 16 hrs, and the ^2H NMR spectrum shows a powder pattern which was motionally narrowed. This type of pattern would be expected for D_2O , which is strongly bound to the polymer and can only undergo restricted rotations. This signal essentially disappears upon exposure to air overnight. This is most likely due to H-D exchange with moisture in the air. Another sample was degraded in D_2O for 8 hrs at 205 °C and then dried under vacuum. This sample shows a ^2H powder pattern similar to that for the previous sample, indicating that there are sites in the cured polymer and in the degraded polymer that can strongly and perhaps irreversibly bind water.

Development of Large Volume CPMAS NMR Probe

A large volume CPMAS Probe is being developed in order to use naturally abundant ^{15}N rather than being required to always isotopically enrich the polyimides. The successful construction of a large volume CPMAS probe would significantly reduce the amount of synthetic chemistry required to make materials and allow for evaluation of commercial formulations of aerospace polyimides.

We have begun this probe development activity by examining current magic angle spinning probe designs for both mechanical and electrical requirements. Precision drawings for critical mechanical parts of the probe have been produced, and construction of the mechanical parts of the probe body/support structure has begun. A double-tuned resonance circuit for testing the performance of individual components was assembled, and it was discovered that the traditional Teflon dielectric capacitors are inherently unsuitable in the high frequency section of the circuit. A source for alternative tunable capacitors with a lower voltage capability, but a higher self-resonant frequency, has been identified and new capacitors have been ordered. Development of a double tuned circuit at 400 MHz remains a challenge and will be a major activity in next years research program.

Appendix B

Second Year Progress Report

Fundamental Models for Predicting Lifetime Performance of High Performance Polymeric Materials

J.M. Caruthers
School of Chemical Engineering
Purdue University
West Lafayette, IN 47907-1283

The primary objective of the Purdue effort is to develop and validate physically realistic models for predicting the lifetime performance of the polymer matrix resin used in high temperature structural composites. As part of our effort we also provide solid state NMR support for research at Wright Laboratories Material Laboratory (Dr. David Curliss-PI) and research at Prairie View A&M (Dr. Paul Biney-PI).

^{15}N Solid State NMR

^{15}N solid state NMR is being used to directly observe the cure and degradation of high temperature polyimides that are currently used in a variety of Air Force applications. The majority of the effort has been focused on developing a large volume magic angle spinning probe so that solid state NMR experiments can be performed using natural abundance ^{15}N rather than isotopically enriching the polyimide precursor materials. This will also enable the investigation of commercial resins, where isotopic enrichment is not possible. The large volume spinning assembly has been constructed. We have also constructed a double tuned circuit for ^{15}N at 40 MHz and at 400 MHz for decoupling ^1H , and we believe that this is the first time a large volume probe that resonates at 400 MHz has been constructed. The complete double tuned circuit with the spinning assembly is currently being assembled and should be ready for testing in the near future.

^{15}N NMR with isotopically enriched polyimide precursors has been used to study hydrolytic degradation in various polyimide systems including AFR700B resins. These studies have provided information on what are the most chemically label sites, which provides guidance in new resin development for environmentally hostile Air Force applications. A publication detailing our solid state NMR studies to date has been prepared and submitted for publication.

Model Network Synthesis

In service applications polymer matrix materials undergo mechanical relaxation simultaneously with chemical degradation; however, there currently is no comprehensive framework for materials, where the state of the material is changing chemically during mechanical relaxation. As a first step in developing the requisite framework we have synthesized a special prepared epoxy resin, where the extent of network formation can be stopped at any predetermined degree of cure. Specifically, one or more of the active hydrogens in diaminodiphenylsulphone (DDS) has been blocked with a methyl group; thus, when the methylated DDS is cured with a standard DGEBA epoxy resin a partially cured, but thermally stable, network is formed. The complete thermal and mechanical response of these model network polymers has been measured. Work will now proceed on measuring the mechanical behavior of systems, where the network changes during the course of the deformation. These experiments will determine if deformation in a chemically curing/degrading material is just a simple combination of the responses of the chemically stable intermediates or if there a more complex coupling between deformation and the rate of chemical reaction. Although there has been considerable anecdotal information that deformation can accelerate reactions in polymer solids, this model system will for the first time allow direct examination of the coupling between deformation and the rate of reaction. These studies have considerable implications on the development of rational accelerated aging methodologies for polymer matrix resins used in Air Force applications, where the material will be subjected to simultaneous chemical and deformation fields during their 20-plus service lifetime.

Appendix C

Third Year Progress Report

Fundamental Models for Predicting Lifetime Performance of High Performance Polymeric Materials

J.M. Caruthers
School of Chemical Engineering
Purdue University
West Lafayette, IN 47907-1283

The primary objective of the Purdue effort is to begin development of physically realistic models for predicting the lifetime performance of the polymer matrix resin used in high temperature structural composites. As part of our efforts we provide solid state NMR support for research at Wright Laboratories - Material Laboratory (Dr. David Curliss) and research at Prairie View A&M University (Dr. Paul Biney-PI).

Solid State NMR Studies of AFR700B Polyimide Resins

Solid state ^{15}N NMR techniques were used to examine newly synthesized ^{15}N labeled model polyimide precursor compounds based on a nadimide, a 6FDA, and a maleimide, where these model compounds were subsequently formulated to endcap an AFR700B resin oligomer ($n=2$). Solid state NMR was used to follow the cure kinetics and degradation reactions of these oligomers, where the oligomer formulation provides greater sensitivity for observation of reactions occurring at the endcaps. All spectra were acquired with a cross polarization sequence and thus relative areas may not be quantitative; however, the increased sensitivity as a result of the cross polarization does allow a more definitive determination of the reaction pathways for the cure reaction and hydrolytic degradation.

The cure reaction was followed at both 150 and 200 °C. As with previous investigations, the major component observed during the cure was the imide; however, significant amounts of both amide and amine were also observed. This indicates that the ring opening amidation reaction and the Michael addition reaction both occur to a much greater extent at the endcaps than along the imide backbone. When fully cured the endcaps are nearly all in the imide form.

Preliminary hydrothermal degradation experiments on these materials show a wide variety of degradation products, including amides and amines. Although these results have not been fully quantified as yet, it appears that nearly a third of the endcap nitrogens have reacted during degradation compared to only a few percent total degradation in a fully labeled system. These systems are currently being studied in more detail in order to better quantify these results.

The key finding is that the reactivity during cure and hydrolytic degradation of the terminal imide linkage in AFR700 resins is substantially different from the backbone imide linkages in this resin. The information has provided significant guidance in the design of new resin systems, which are currently being developed at Wright Laboratories. These results were presented in part at the SAMPE Technical Conference in November of 96.

Development of Large Volume ^{15}N MAS Probe

We have continued development of the large volume ^{15}N MAS probe in order to eliminate the costly and time consuming step of synthesizing ^{15}N labeled materials. A stand-alone bench spinner was built around the prototype stator in order to test and evaluate the stator and rotor performance. In addition, this bench spinner can later be used to spin pack powder samples to insure that they will spin well in the probe. With the prototype stator, we were able to spin a 10 mm diameter rotor greater than 1 kHz. While this is adequate for testing purposes, it is probably not sufficient for ^{15}N MAS spectra. The stator design has been reevaluated and changes are being implemented for improved spinning capability.

Specific details concerning the stator redesign are as follows: A new stator was designed with part of the bearing area relieved in order to reduce friction. This stator was made from Macor[®] machinable glass ceramic by an outside contractor. Close examination showed that stator contains one large and several smaller cracks. Tests in the bench spinner housing indicate that the stator may still work mechanically; however, the structural integrity of the stator remains compromised and will likely result in premature failure of the part. A new stator is currently being machined with a new contractor that has more experience in working with Macor[®]. Additional design modifications were made to the Delrin housing for increasing gas input and exhaust, since there appears to be some friction on the bottom rotor cap at the support contact. After spinning for some time, the Kel-F rotor caps show considerable wear. This is not surprising since the rotor and sample have a total mass of nearly 7 grams. An additional air bearing is needed to support the mass of the rotor and sample and to reduce friction on the rotor endcaps. Modification of the housing endcaps to provide an air bearing at these points is in progress. The modifications discussed above will also be incorporated in the probe and will include openings for electrical feed-thru's and for the magic angle adjustment mechanism. We anticipate that these improvements will enable a sufficient rate of rotation for measurement of the ^{15}N spectra.

We have succeeded in making a double tuned circuit using a large volume coil; however, tests indicate that the large coil becomes very inefficient at high

frequencies (i.e. 400 MHz). Since proton decoupling is not necessary for many of the types of nitrogen of interest, we have opted to initially incorporate a single tuned, large volume, broadband circuit into the probe for observation of ^{13}C to ^{15}N (100 to 40 MHz at 9.4T) without decoupling. This circuit incorporates high voltage variable capacitors and will require rebuilding the circuit board, several probe body components, and new electrical standoff for the capacitors. The redesigned circuit should be completed in the near future and will then be incorporated with the redesigned stator assembly.

Model Thermoset Synthesis and Characterization

When used as structural components in actual applications, polymer matrix materials typically undergo simultaneous chemical reaction and mechanical relaxation; however, there is currently no comprehensive framework for materials where the polymer structure is changing chemically during mechanical relaxation. The objective of this part of the project is to begin developing an appropriate nonlinear viscoelastic constitutive model that includes a fundamentally reasonable description of the reaction mechanism and kinetics.

As a first step towards developing and validating an appropriate constitutive framework for polymeric materials undergoing simultaneous mechanical relaxation and chemical reaction, we have prepared a special epoxy resin, where the extent of network formation can be 'stopped' at any predetermined degree of cure. Specifically, one or more of the active hydrogen in diamino-diphenyl-sulfone (DDS) has been blocked with a methyl group; consequently, a partially cured yet thermally stable network results when DDS is cured with a diglycidyl-ether of bis-phenol A (DGEBA) di-epoxide. The complete mechanical and thermal properties of these 'partially cured' epoxy thermoset polymers can now be measured.

The T_g of cured resin decreased from 132 °C to 121 °C as the curing agent was changed from pure DDS to the methylated diamine. Using DSC we have also measured the time dependent enthalpy relaxation during heating for a series of six different methylated and unmethylated DDS curing agents as a function of both annealing temperature and annealing time. Somewhat unexpectedly the enthalpy relaxation does not exhibit universal behavior when the enthalpy relaxation is normalized to the glass transition temperature of each material, indicating that the extent of cure affects not just the T_g of the resin but the details of the relaxation response as well. The data is currently being fit to the traditional Tool-Narayanswamy model in order to determine how the extent of cure affects both the shape of the relaxation spectra as well as its temperature and volume dependence. Once we are able to describe the enthalpy relaxation behavior of each of these chemically stable epoxies, we will then measure the enthalpy relaxation of a curing system to assess if it can be modeled as just the

evolution of a series of chemically stable systems. This study will provide key information in determining just what type of constitutive structure is needed to describe systems that are undergoing simultaneous chemical reaction and viscoelastic relaxation.

Appendix D

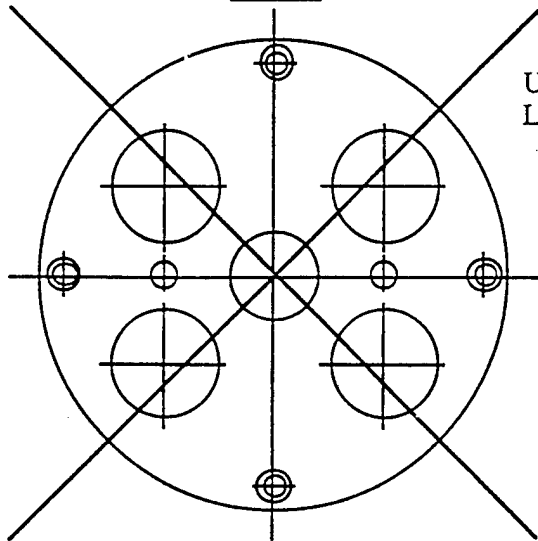
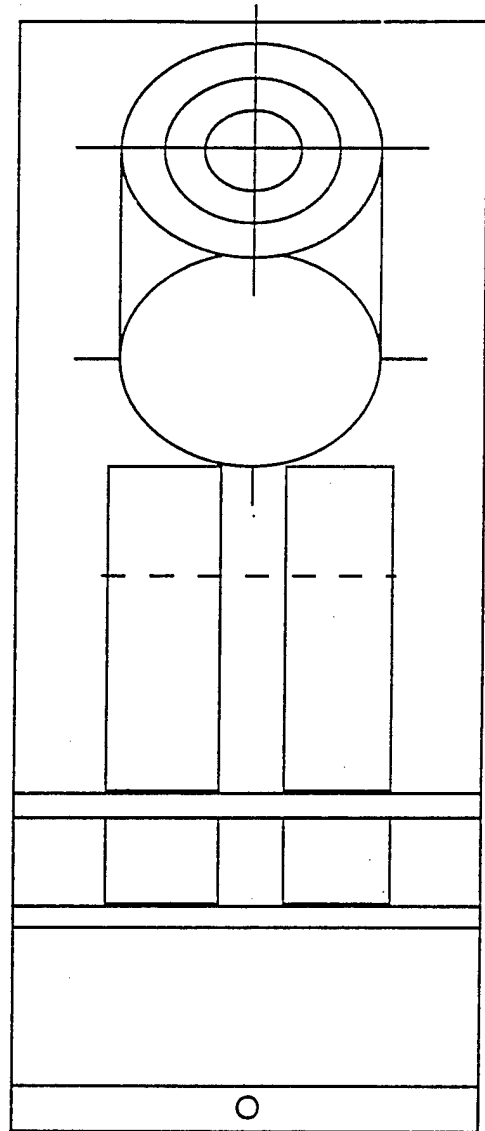
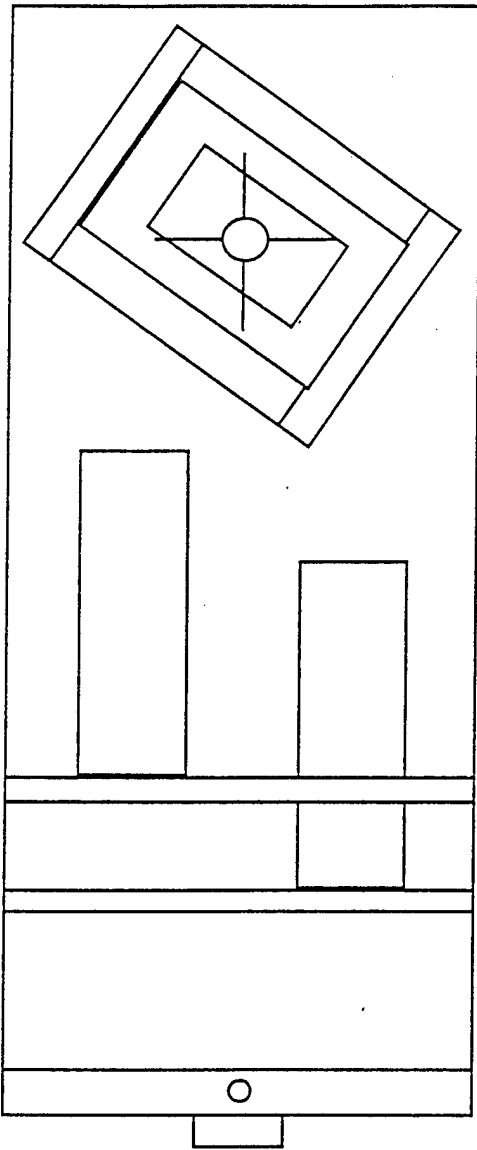

Upper Probe Body
Layout & Assembly

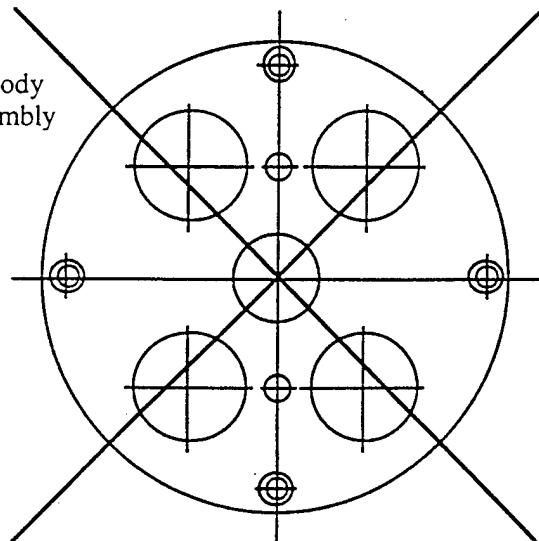

Lower Flange /
Support Ring
Scale 1" = 1"

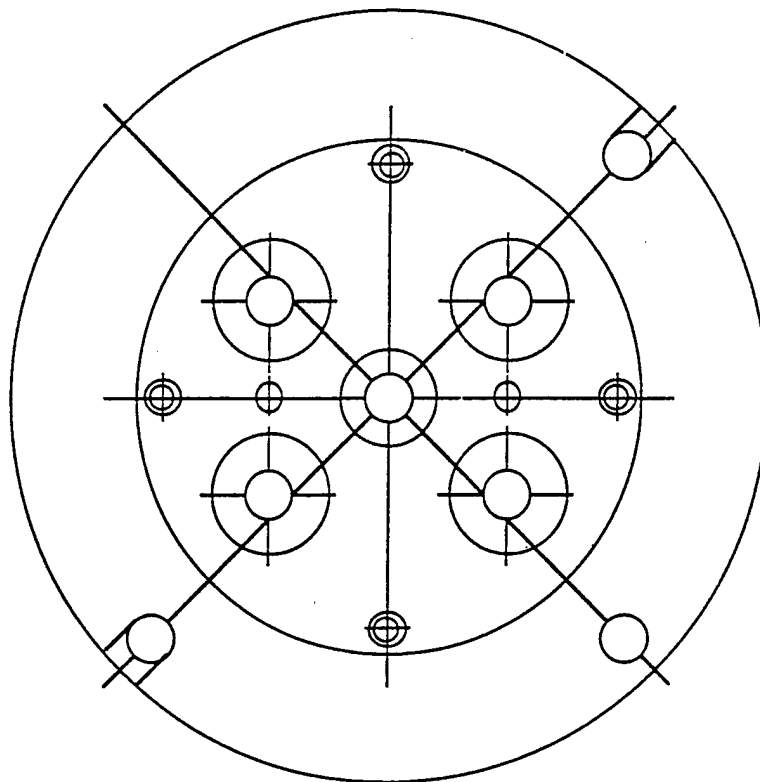

Upper Flanges
2 required
Scale 1" = 1"

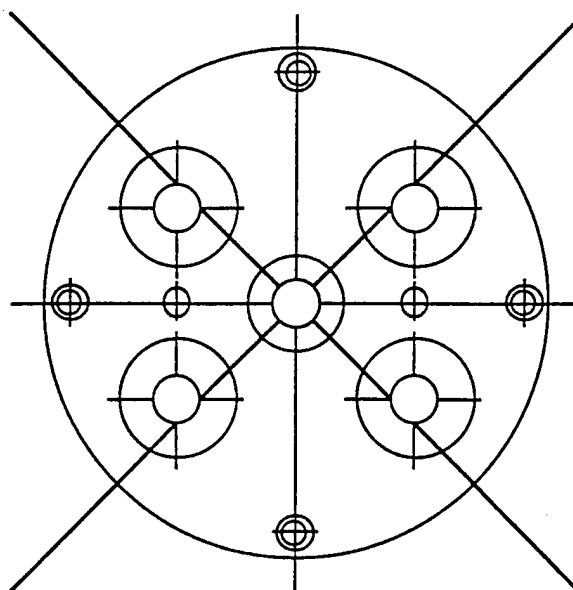

Delrin Housing
Cross-Section
Scale 0.5" - 1"

All dimensions are
 ± 0.001 in. unless
specified.

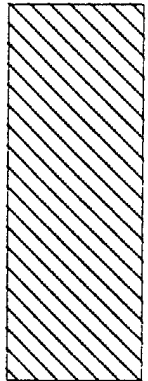
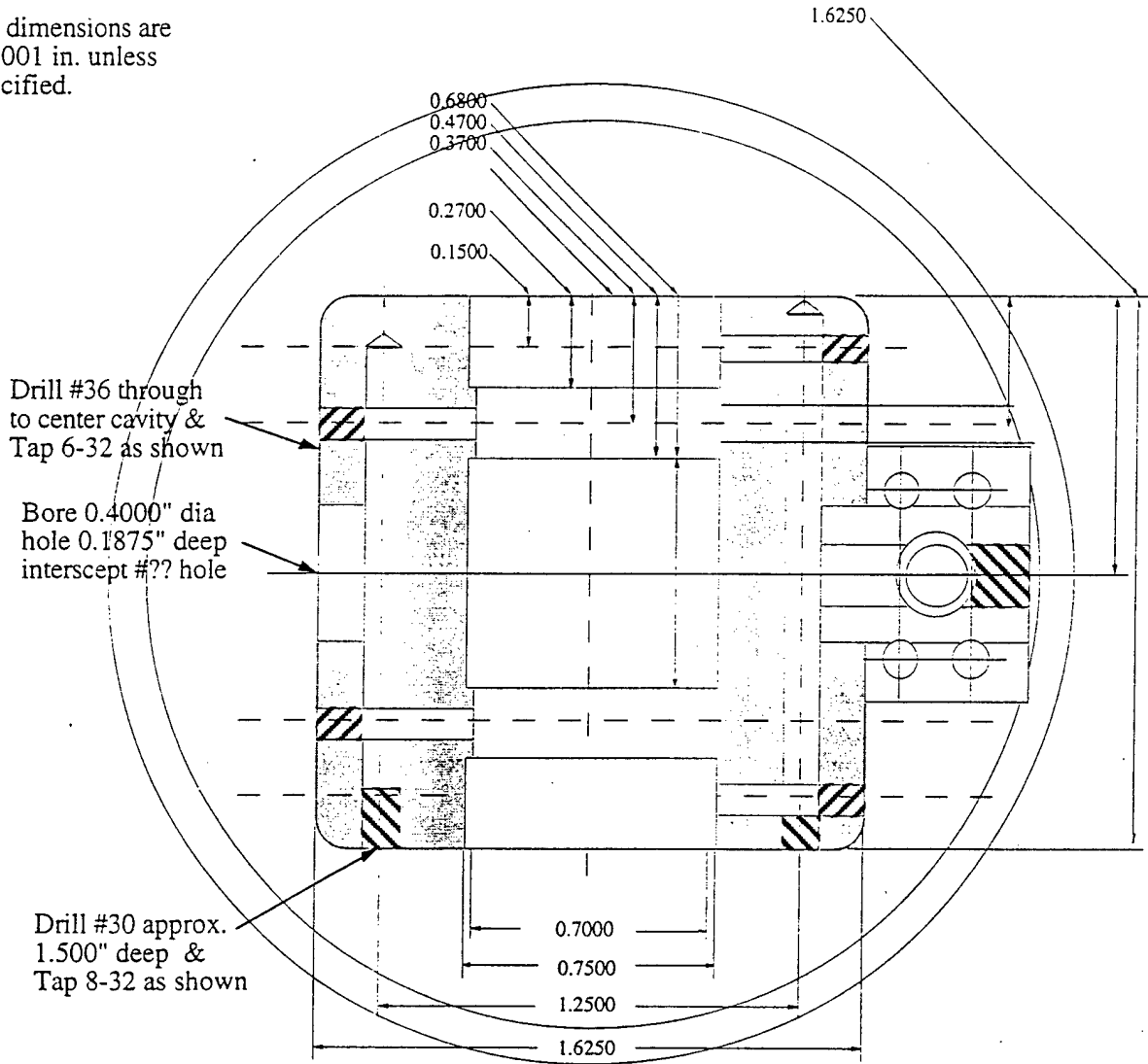

BAC 06/05/98

Delrin Housing
 Front View
 Scale 0.5" - 1"

All dimensions are
 ± 0.001 in. unless
 specified.

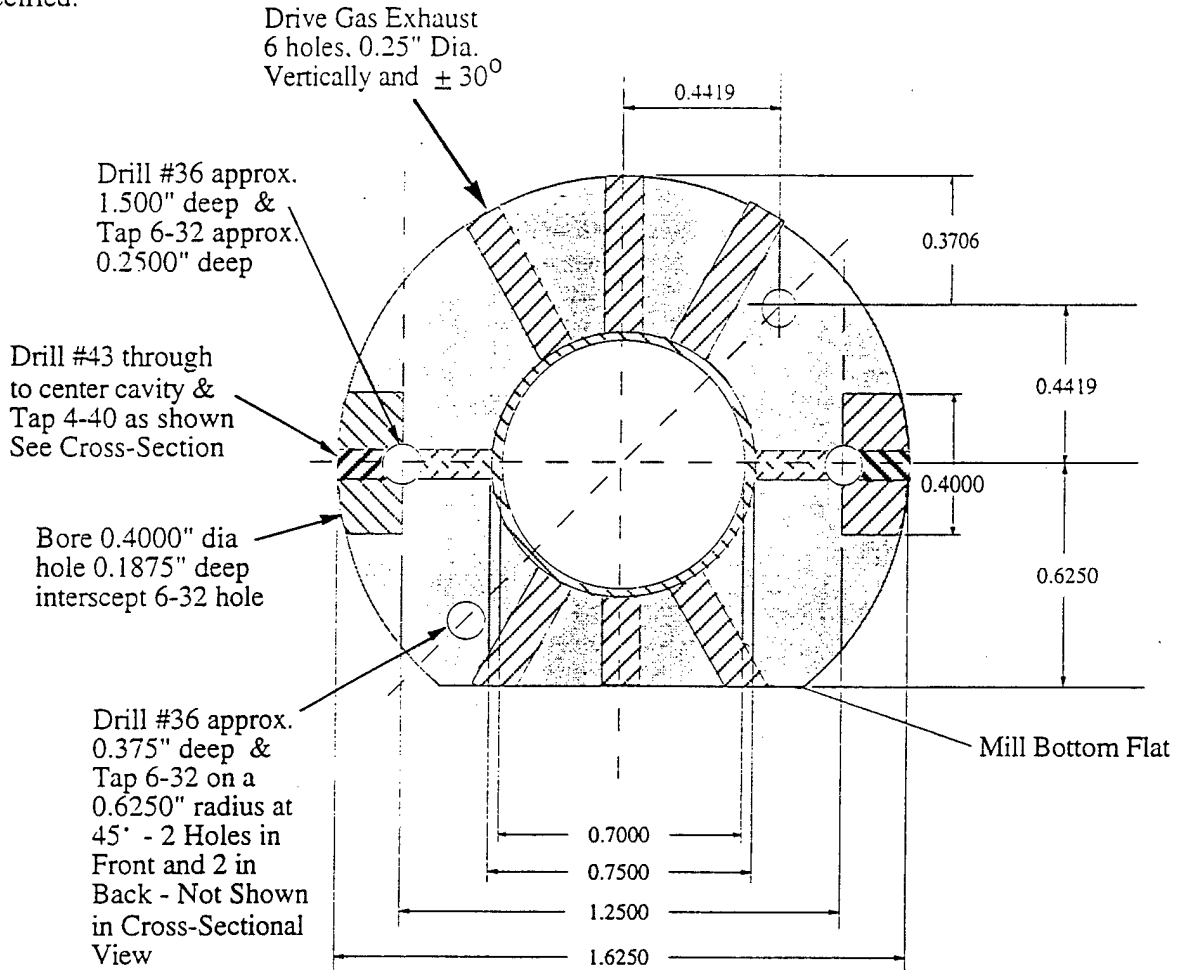

BAC 06/05/98

Delrin Housing
Side View
Scale 0.5" - 1"

All dimensions are
 ± 0.001 in. unless
specified.

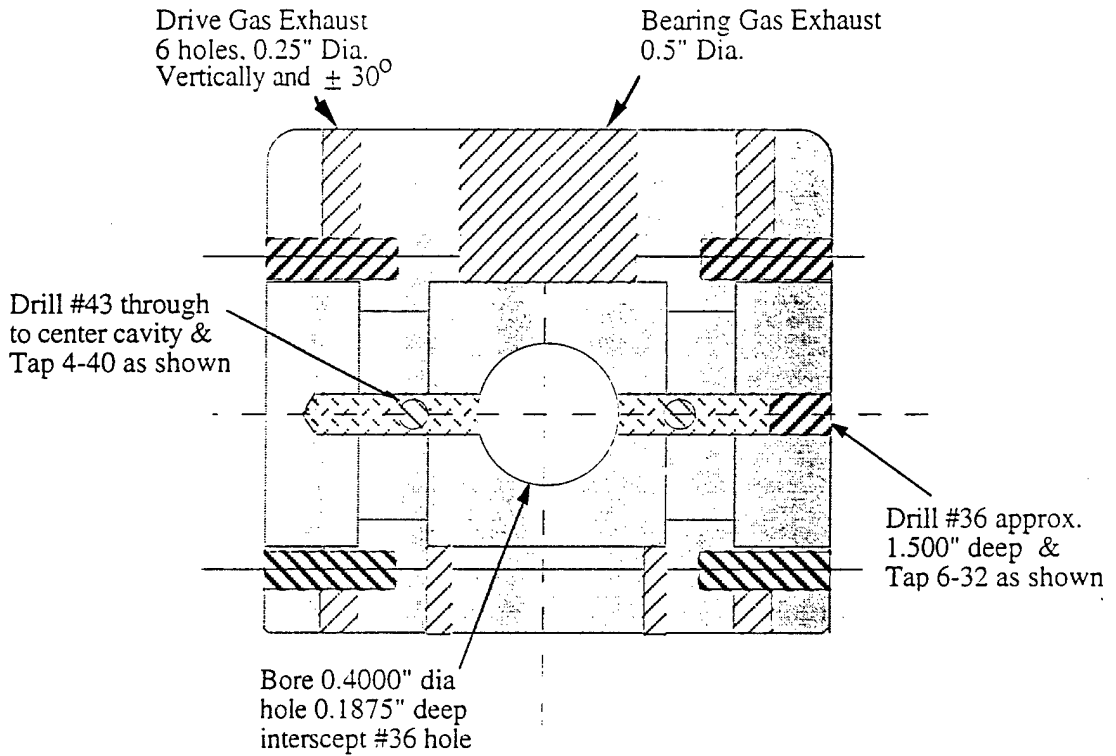

BAC 06/05/98

LVMAS STATOR
for 10mm Dia. Rotor

All dimensions are
+0.001 in. unless
specified. Radius
outer corners.

Cross-sectional View
(Scale 1" = 0.5")

Materials:
1 Phos Bronze
1 Macor

Bearing gas exit holes.
Three rows of six holes
0.0625 in. diameter
equally spaced around
circumference

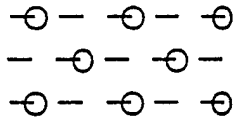

Bearing Gas Holes
see detail front
view.

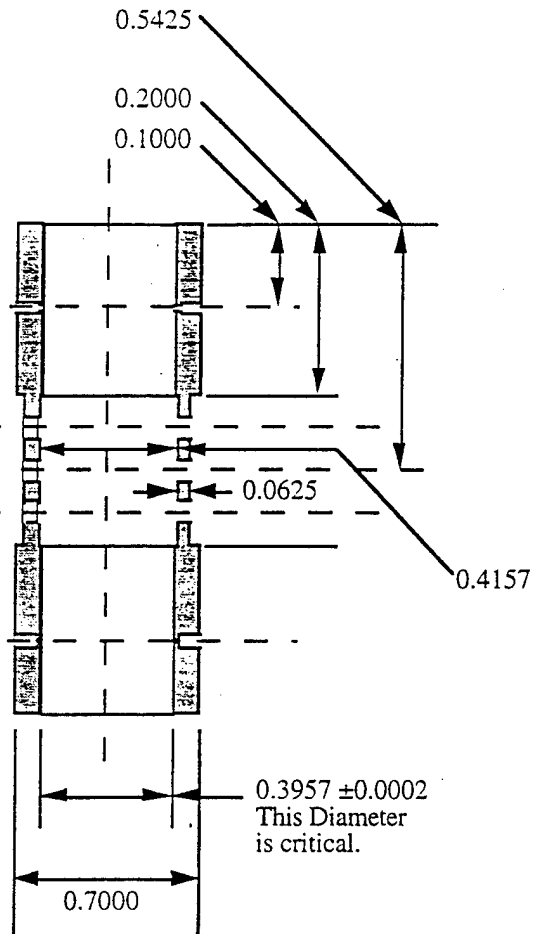

Front View (Scale 1" = 0.25")

Bearing Groove
approx 0.1 deep

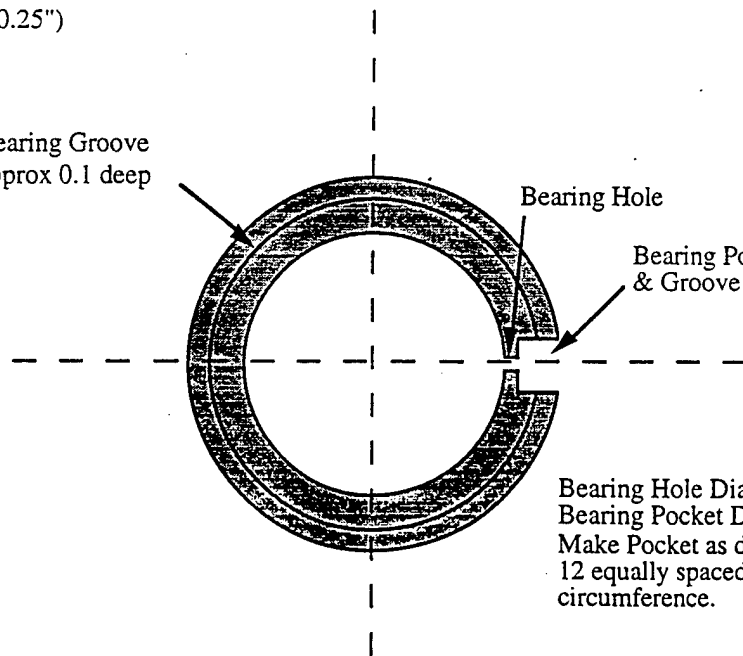

Bearing Hole Dia. is 0.0135 (#80)
Bearing Pocket Dia. is 0.0810 (#46)
Make Pocket as deep as possible.
12 equally spaced about
circumference.

BAC 07/16/98

HOUSING CAP
for 10mm Dia. Rotor

Cross-sectional View
(Scale 0.5" = 1")

All dimensions are
+0.001 in. unless
specified. Radius
outer corners.

Matl.
2 MACOR
2 Phosphor Bronze

Note: Rings with both right and
left offset must be made for top
and bottom so that driving direction
is the same.

Drive Air Supply Ring
0.125 wide and as deep
as possible

Drive Air Supply must
line up with Housing Supply

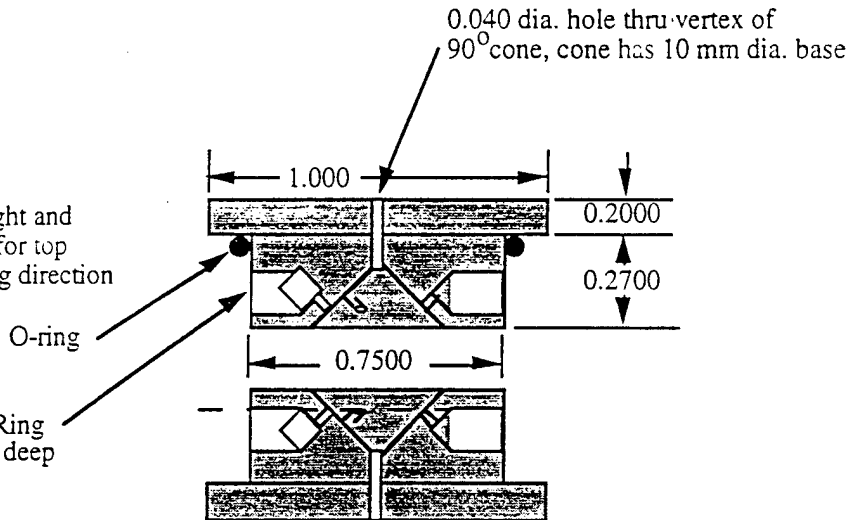

Front View (Scale 0.5" = 1")

Drive Hole Diameter is 0.0200 (#76)
6 equally spaced about circumference.
Offset must be on the same side on
each end. **Make drive pocket as
deep as possible. Pocket does not
have flat bottom.

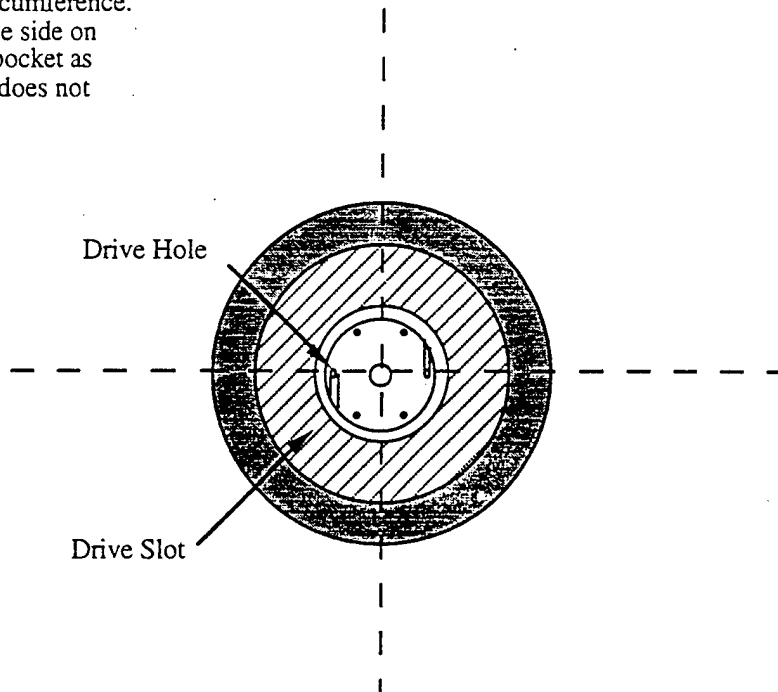

BAC 07/06/98

ROTOR CAP
for 10mm Dia. Rotor

Cross-sectional View
(Scale 0.5" = 1")

All dimensions are
+0.001 in. unless
specified. Radius
outer corners.

Matl. Vespel

Note: Both right and left offset
must be made for top and bottom so
that driving direction is the same.

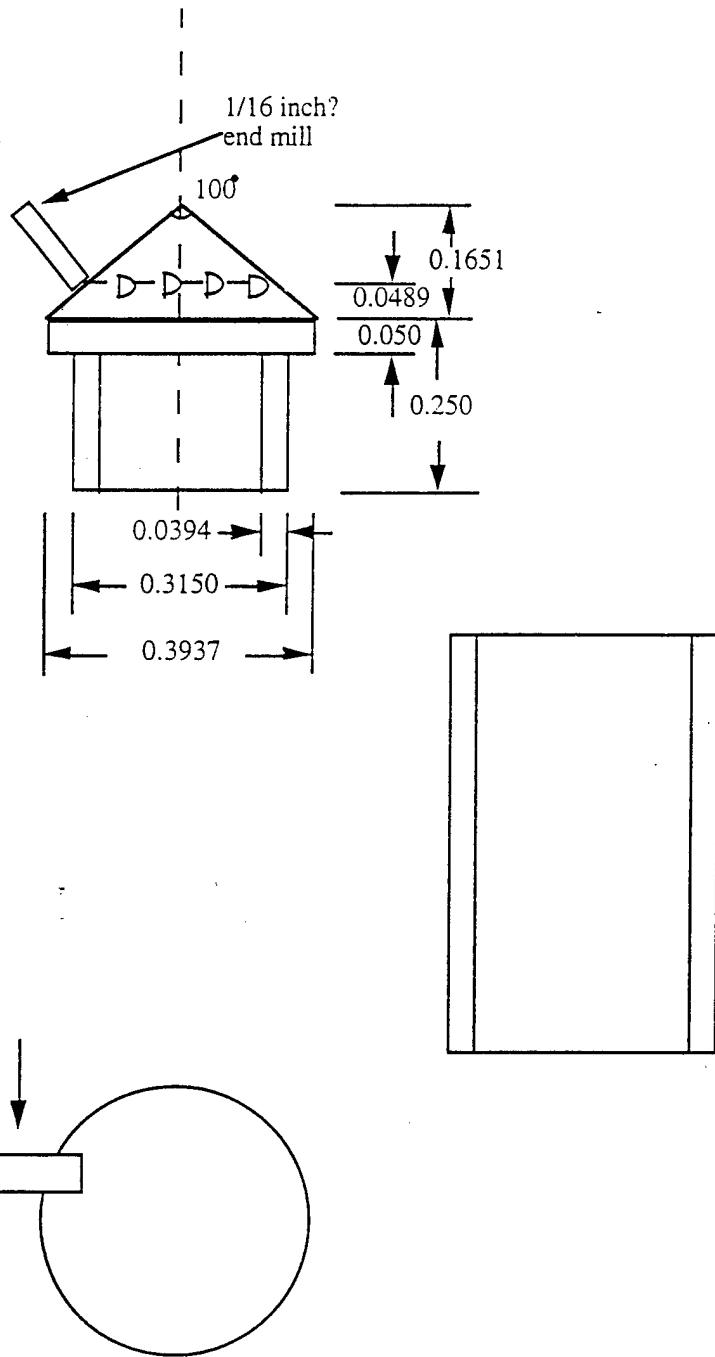

BAC 08/10/98