

AD_____

Award Number: DAMD17-96-C-6069

TITLE: Breast Cancer Center Support Grant

PRINCIPAL INVESTIGATOR: Marc Lippman, M.D.

CONTRACTING ORGANIZATION: Georgetown University
Washington, DC 20057

REPORT DATE: September 1999

TYPE OF REPORT: Annual

PREPARED FOR: U.S. Army Medical Research and Materiel Command
Fort Detrick, Maryland 21702-5012

DISTRIBUTION STATEMENT: Approved for public release
distribution unlimited

The views, opinions and/or findings contained in this report are those of the author(s) and should not be construed as an official Department of the Army position, policy or decision unless so designated by other documentation.

DTIC QUALITY INSPECTED 4

20001027 010

PII Redacted

REPORT DOCUMENTATION PAGE

Form Approved
OMB No. 074-0188

Public reporting burden for this collection of information is estimated to average 1 hour per response, including the time for reviewing instructions, searching existing data sources, gathering and maintaining the data needed, and completing and reviewing this collection of information. Send comments regarding this burden estimate or any other aspect of this collection of information, including suggestions for reducing this burden to Washington Headquarters Services, Directorate for Information Operations and Reports, 1215 Jefferson Davis Highway, Suite 1204, Arlington, VA 22202-4302, and to the Office of Management and Budget, Paperwork Reduction Project (0704-0188), Washington, DC 20503

1. AGENCY USE ONLY (Leave blank)		2. REPORT DATE September 1999	3. REPORT TYPE AND DATES COVERED Annual (01 Sep 98 - 31 Aug 99)	
4. TITLE AND SUBTITLE Breast Cancer Center Support Grant			5. FUNDING NUMBERS DAMD17-96-C-6069	
6. AUTHOR(S) Marc Lippman, M.D.				
7. PERFORMING ORGANIZATION NAME(S) AND ADDRESS(ES) Georgetown University Washington, DC 20057 e-mail: lippmanm@gunet.georgetown.edu			8. PERFORMING ORGANIZATION REPORT NUMBER	
9. SPONSORING / MONITORING AGENCY NAME(S) AND ADDRESS(ES) U.S. Army Medical Research and Materiel Command Fort Detrick, Maryland 21702-5012			10. SPONSORING / MONITORING AGENCY REPORT NUMBER	
11. SUPPLEMENTARY NOTES				
12a. DISTRIBUTION / AVAILABILITY STATEMENT Approved for public release distribution unlimited				12b. DISTRIBUTION CODE
13. ABSTRACT (Maximum 200 Words) This document represents the annual report for our Breast Cancer Center Support Grant. Our grant consists of five areas, three projects and two cores. Projects include: Project 1 - Impact of Genetic Testing for Breast Cancer Susceptibility; Project 2 - A Coordinated Approach to Breast Cancer Diagnosis; and Project 3 - Development of Novel Antiangiogenic Therapies in Metastatic Breast Cancer. These projects are supported by Core 1 - Patient Accession Core, and Core 2 - Cancer Clinical and Economic Outcomes Evaluations Core. During the project period, each of the cores have been fully functional, and each of the projects continues to meet its objectives. Detailed summaries of the work in progress is provided in each of the project areas. Taken together, we believe that these projects, supported by their appropriate cores, have been successful in meeting their statements of work, and in fulfilling their scientific objectives during the granting period.				
14. SUBJECT TERMS Breast Cancer Center			15. NUMBER OF PAGES 231	
			16. PRICE CODE	
17. SECURITY CLASSIFICATION OF REPORT Unclassified	18. SECURITY CLASSIFICATION OF THIS PAGE Unclassified	19. SECURITY CLASSIFICATION OF ABSTRACT Unclassified	20. LIMITATION OF ABSTRACT Unlimited	

FOREWORD

Opinions, interpretations, conclusions and recommendations are those of the author and are not necessarily endorsed by the U.S. Army.

___ Where copyrighted material is quoted, permission has been obtained to use such material.

___ Where material from documents designated for limited distribution is quoted, permission has been obtained to use the material.

___ Citations of commercial organizations and trade names in this report do not constitute an official Department of Army endorsement or approval of the products or services of these organizations.

___ In conducting research using animals, the investigator(s) adhered to the "Guide for the Care and Use of Laboratory Animals," prepared by the Committee on Care and use of Laboratory Animals of the Institute of Laboratory Resources, national Research Council (NIH Publication No. 86-23, Revised 1985).

For the protection of human subjects, the investigator(s) adhered to policies of applicable Federal Law 45 CFR 46.

___ In conducting research utilizing recombinant DNA technology, the investigator(s) adhered to current guidelines promulgated by the National Institutes of Health.

___ In the conduct of research utilizing recombinant DNA, the investigator(s) adhered to the NIH Guidelines for Research Involving Recombinant DNA Molecules.

___ In the conduct of research involving hazardous organisms, the investigator(s) adhered to the CDC-NIH Guide for Biosafety in Microbiological and Biomedical Laboratories.

Marc Lippman MQ 10/4/95
PI - Signature Date

TABLE OF CONTENTS

Front Cover

Standard Form 298

Foreword

Table of Contents.....	1
Principal Investigator's Introduction.....	2
Project 1	
<i>Impact of Genetic Testing for Breast Cancer Susceptibility.....</i>	3
Project 2	
<i>A Coordinated Approach to Breast Cancer Diagnosis.....</i>	9
Project 3	
<i>Development of Novel Antiangiogenic Therapies in Metastatic Breast Cancer....</i>	19
Core 1	
<i>Patient Accession Core.....</i>	30
Core 2	
<i>Cancer Clinical and Economics Core.....</i>	38

Appendix Packet

PRINCIPAL INVESTIGATOR'S INTRODUCTION

Since the inception of our Breast Cancer Center Grant, the participants have worked closely with one another to achieve the goals of the grant. As described within our report, **Project 1 (Impact of Genetic Testing For Breast Cancer Susceptibility)** provides data, which are the first to document predictors of uptake in a high-risk clinically-based population. These results suggest that cancer worries may motivate testing use. **Project 2 (A Coordinated Approach to Breast Cancer Diagnosis)** is actively recruiting patients and gathering data on patients with both benign and malignant disease, despite having encountered significant patient test scheduling. The overall goals of **Project 3 (Development of Novel Antiangiogenic Therapies in Metastatic Breast Cancer)** are to evaluate the effects of angiogenic inhibitors in prospective clinical trials in breast cancer patients. We have now successfully completed a randomized phase I/II study of thalidomide, which has provided insights into the relative lack of activity of high dose (800-1200 mg) and standard dose (200 mg) thalidomide. Furthermore, we have finished a Phase I trial that has provided more information regarding our proposal to conduct a randomized trial regarding whether TNP-470 contributes added benefit to the chemotherapeutic agent, paclitaxel.

Outstanding efforts have also been demonstrated by the two cores support by this award. Based on an analysis of **Core 1 (Patient Accession Core)** experience, and a review of other successful and unsuccessful efforts at minority clinical trials accrual, the LCC is proposing to expand minority accrual to breast cancer research trials. This will be accomplished by expanding an existing network of oncology office practices, and their affiliated internist, ob/gyn and surgical practices. In addition, **Core 2 (Cancer Clinical and Economic Outcomes Evaluation Core)** is extending the state-of-the-art science of conducting outcomes research by composing a unique cross-disciplinary research team with the methodological expertise to evaluate the costs and benefits of new and existing cancer services. Detailed information about each of the projects, and the two cores which support them, is provided on the following pages.

PROJECT 1: IMPACT OF GENETIC TESTING FOR BREAST CANCER SUSCEPTIBILITY

I. INTRODUCTION: Up to 10% of breast/ovarian cases are due to an alteration in the BRCA1 or BRCA2 genes. Women who have an alteration in either of these genes have an estimated 55-85% risk of developing breast cancer and a 15-60% chance of getting ovarian cancer. Other cancers also occur with increased frequency in gene carriers, such prostate cancer. First-degree relatives of individuals with a BRCA1 or BRCA2 mutation have a 50% chance of carrying the altered gene. Thus, men may also derive clinically significant information from genetic testing for themselves and their family members.

This study is designed to gather data on the determinants of testing uptake, as well as the medical and psychological implications of genetic counseling and testing. We are also interested in learning about individuals who decline such counseling and testing and how this choice impacts their well-being and medical decision-making. (Note: For brevity, this program is referred to as CARE, Cancer Assessment and Risk Evaluation.) The specific aims of this project are as follows:

- 1) to identify determinants of who decides to undergo BRCA1/2 testing;
- 2) to evaluate the short- and long-term impact of BRCA1/2 testing on quality of life;
- 3) to evaluate the impact of genetic testing on prevention and surveillance practices;
- 4) to identify early predictors of psychological morbidity and nonadherence among participants in genetic testing programs; and
- 5) to develop a preliminary model to estimate the costs of BRCA1/2 testing per quality-adjusted life years ahead.

II. BODY

A. Accrual and Uptake of BRCA1/2 Testing

1. Major sources of recruitment include Georgetown internal providers, relatives of individuals who test positive, and external providers.

2. To date, **773** individuals have completed the initial baseline phone interview (a 40% increase over last year). Approximately **93%** of the individuals who completed baselines are Caucasian and **6%** are minorities (see PAC for detailed race breakdown). Of note, **690** individuals participated in a pre-test genetic counseling session. **68%** were probands and **32%** were relatives of a positive individual. Of the relatives who completed a pre-test session, **76%** were females and **24%** were males.

3. Of the 690 individuals who completed an initial genetic counseling session, **563** (82%) chose to get tested and receive their results. Result outcomes are summarized below:

BRCA 1/2 Positive - **172**
BRCA 1/2 Mutation Negative - **221**
BRCA 1/2 True Negative - **103**

BRCA 1/2 Result of Unknown Significance - 41
Partial Negatives (BRCA1 or BRCA2 negative for full testing)- 26

4. We have conducted an analysis of the predictors of testing decisions. This study revealed that women with higher levels of cancer worries were more likely to receive test results, while those with high levels of spiritual faith were less likely.

B. Psychosocial Impact of Testing

1. To date, **598** individuals completed the 1 month follow-up interview; **471** have completed the 6 month interview; and **354** have completed the final 12 month interview. These numbers include those who decline testing at or before their initial genetic counseling visit and the follow-up after results are given in a second genetic counseling session.

2. A preliminary analysis has shown that unaffected carriers of BRCA1/2 mutations report higher levels of carrier worries at 6-month follow-up than noncarriers, but not higher levels of general distress symptoms.

C. Preliminary model on the cost-effectiveness of counseling and testing for BRCA1/2 susceptibility mutations in high risk women.

A detailed report of progress on this aim can be found in the report for Core #2: The Cancer Clinical and Economic Outcomes Core.

1. Costs: A large portion of the costs in this cost-effectiveness analysis will be the costs of providing genetic counseling and testing of women who are at risk of having a mutation. Bill Lawrence and co-investigators on this proposal performed a cost analysis of providing counseling and full BRCA1/2 gene sequencing to women in the CARE program. This analysis included the cost of the personnel time, materials, and included participant time and caregiver costs. We calculated the cost of providing standard genetic counseling (without testing) to probands to be \$205; adding testing and disclosure of results to this counseling increased total costs to \$2050. While the cost of counseling and testing together exceeded \$2000, the cost of providing the counseling (including disclosure of results) comprised only 16% of the total cost. We conclude from this analysis that: 1) while counseling is an important part of a genetic evaluation, it has a low cost relative to testing; and 2) since the cost of counseling is a small part of the overall cost of counseling and testing, replacement of detailed genetic counselor counseling with a shorter time of physician counseling would not significantly lower costs. In addition to the cost of testing and counseling, the cost of treatment of cancer will be needed for the full cost-effectiveness analysis. We are currently working with the National Cancer Institute to obtain costs of breast cancer treatment using Surveillance, Epidemiology, and End-Results (SEER) - Medicare linked cost data.

2. Quality of Life: We measure cost-effectiveness in this study in units of dollars per quality-adjusted life years (QALYs) saved. To express outcomes in QALYs, we incorporate both expected survival and health utilities, or participant's preferences for the health outcomes of interest (e.g. having a prophylactic mastectomy, or having localized breast cancer). A detailed report of our quality of life survey work and a table of preliminary utility values for the health states of interest can be found in the Core #2 report. Briefly, while we have been

interviewing participants to determine health utilities using two assessment methods, the time trade-off assessment (TTO) and the linear rating scale assessment (LRS), we have found that while the LRS has been a reliable instrument for telephone surveys, the TTO has not been. We have thus terminated the TTO assessments, and collecting utilities for health states by LRS.

3. Cost-Effectiveness: We use a computer simulation model to determine cost effective-ness of BRCA1/2 counseling and testing, simulating a cohort of high risk women who either undergo counseling and testing, counseling alone, or no counseling or testing. We have finished programming the base computer model, and are currently working on finishing the formal meta-analyses for parameter estimates and completing cost data collection. Preliminary findings based upon estimated parameter values can be found in the Core # 2 report.

III. KEY RESEARCH ACCOMPLISHMENTS

- Uptake: These data are the first to document predictors of uptake in a high-risk clinically based population. These results suggest that cancer worries may motivate testing use. This is important because the self-selection process may result in a more highly distressed group of participants. The finding that spiritual faith deters testing is of interest and warrants further investigation.
- Impact: Thus far, substantial adverse psychological effects have not been observed in individuals who pursue genetic testing, including those with positive test results. However, our data are the first to show significant effects of testing on cancer worries. Investigation of the quality of life impact of these effects is ongoing.
- Cost: The costs for genetic counseling are low relative to the costs involved in BRCA1/2 testing. Thus, findings derived from cost analyses in this research setting suggest that, in clinical practice, replacement of comprehensive genetic counselor counseling with a shorter time of physician counseling would not significantly lower overall costs.

IV. REPORTABLE OUTCOMES

A. Manuscripts and Abstracts from Project Data

Audrain J, Schwartz MD, Lerman C, Hughes C, Peshkin BN, Biesecker B. Psychological distress in women seeking genetic counseling for breast-ovarian cancer risk: the contributions of personality and appraisal. Annals of Behavioral Medicine. 1997; 19:370-377.

Benkendorf JL, Peshkin BN, Lerman C. Impact of genetic information and genetic counseling on public health. In Khoury MJ, Burke W, Thomson E (eds.), Genetics and Public Health: Translating Advances in Human Genetics into Public Health Action. NY: Oxford University Press, in press.

Brunet JS, Ghadirian P, Rebbeck TR, Lerman C, et al. Effect of smoking on breast cancer in carriers of mutant BRCA1 or BRCA2 genes. Journal of the National Cancer Institute. 1998; 90(10):761-6.

Frank TS, Manley SA, Olopade OI, ...Isaacs C, Peshkin B, et al. Sequence analysis of BRCA1 and BRCA2: Correlation of mutations with family history and ovarian cancer risk. Journal of Clinical Oncology. 1998; 16:2417-2425.

Ganguly T, Citron M, Stott J, Isaacs C, Peshkin B, Godmilow L, Weber B, Ganguly A. Novel BRCA mutations in African American individuals with breast and ovarian cancer. American Journal of Human Genetics. 1998; 63(4)Supp:366.

Hughes C, Lynch H, Durham C, Snyder C, Lemon S, Narod S, Fulmore C, Main D, Lerman C. Communication of BRCA1/2 test results in hereditary breast cancer families. Cancer Research Therapy and Control, in press.

Isaacs C, Peshkin B, Benkendorf J, Hughes C, Lerman C. Interest in testing for BRCA1: correlation between patient risk and desire for testing. Proceedings of the American Society of Clinical Oncology. 1996; 15:329.

Isaacs C, Peshkin B, Reutenauer J, Reed M, Main D, Lerman C. Cancer screening practices in women from high risk breast cancer families. Proceedings of the American Society of Clinical Oncology. 1997; 17:1916.

Isaacs C, Peshkin BN, Lerman C. Evaluation and management of women with a strong family history of breast cancer. In Harris JR, Lippman ME, Morrow M, Hellman S (eds.), Diseases of the Breast (2nd edition). Philadelphia, PA: J.B. Lippincott, in press.

Jernstrom H, Lerman C, Ghadirian P, Lynch H, et al. Pregnancy increases the risk of early breast cancer in BRCA1 and BRCA2 carriers. Lancet, in press.

Lerman C, Peshkin BN, Hughes C, Isaacs C. Family disclosure in genetic testing for cancer susceptibility: Determinants and consequences. Journal of Health Care Law and Policy 1998; 1(2):353-372.

Lerman C, Peshkin BN. Psychosocial issues in BRCA1/2 testing. In Bowcock AM (ed.), Breast Cancer: Molecular Genetics, Pathogenesis, and Therapeutics (Contemporary Cancer Research series). NJ: Humana Press, 1999 (pp. 247-266).

Peshkin BN, Lerman C, Isaacs C, Brown KM, de Leon A, Abbaszadegan MR. A detection panel of prevalent mutations in BRCA1/2 genes is sensitive and cost effective in an initial screen of high risk patients. Proceedings of the American Association of Cancer Research. 1998; 39:3232.

Peshkin BN, Lerman C. Genetic counseling for hereditary breast cancer. Lancet. 1999; 353:2176-2177.

Qwang-Gohrke S, Weikel W, Risch H, Vesprini D, Abrahamson J, Lerman C, et al. Intron variants of the p53 gene are associated with increased risk for ovarian cancer but not in carriers of BRCA1 or BRCA2 germline mutations. British Journal of Cancer, in press.

Schwartz M, Hughes C, Roth J, Main D, Peshkin B, Isaacs C, Kavanagh C, Lerman C. Racial differences in use of BRCA1/BRCA2 genetic testing in high risk breast cancer probands. Annals of Behavioral Medicine. 1999; 21:S182.

Shattuck-Eidens D, Oliphant A, McClure M, ...Isaacs C, Peshkin B, Lippman ME, et al. BRCA1 sequence analysis in women at high risk for susceptibility mutations: Risk factor analysis and implications for genetic testing. Journal of the American Medical Association. 1997; 278:1242-1250.

Tonin P, Weber B,Y, Offit K, ...Lerman C, Peshkin B, et al. Frequency of recurrent BRCA1 and BRCA2 mutations in Ashkenazi Jewish breast cancer families. Nature Medicine. 1996; 2(11):1179-1183.

B. Other Reportable Outcomes

1. Registry development. With funding from other grants, participants in the CARE program are invited to contribute to our Familial Cancer Registry. This registry is a repository for blood and tumor DNA, as well as pathology reports. A database containing risk factor information has also been developed. Data from CARE participants have been contributed, along with data from several other sites, to determine the effects of oral contraceptives, cigarette smoking, parity, Tamoxifen, prophylactic surgery, and other factors on cancer risks in mutation carriers (see publication list).

2. Funding applied for based on this work. Based on this work, funding has been awarded for an NCI supported study, "Comparing Models of Counseling for BRCA1/2 Testing." This randomized study is evaluating the impact of psychosocial telephone counseling versus standard genetic counseling in female mutation carriers. High-risk individuals ascertained through the CARE program may also be invited into the NCI funded "Cancer Genetics Network." This is a grant for infrastructure that will enable researchers to have access to interested participants for cancer genetics studies. In addition, a subcontract was recently awarded by NIH to study the efficacy of prophylactic mastectomy and oophorectomy in mutation carriers.

3. Training supported by this award. Since 1998, three genetic counseling students from two accredited programs (National Human Genome Research Institute and University of Michigan) completed clinical rotations at Georgetown University. Under the close supervision of the genetic counselors, these individuals had an opportunity to observe and take part in the genetic counseling of research participants. In addition, a medical oncologist from Modena, Italy completed an 8 week fellowship granted by the UICC and began a research project about the clinicopathologic features of breast cancers in women with BRCA1/2 mutations.

V. CONCLUSIONS

A. **Summary:** Our findings show that a majority of individuals who complete a screening interview opt to participate in genetic counseling and testing. There do not appear to be significant adverse psychological effects as a result of participation in genetic counseling and testing, even among those who test positive. Data obtained from this study have also been used to estimate the costs of providing genetic counseling and testing, which may be useful in clinical practice. We are continuing to evaluate the decision-making patterns of participants with respect to medical options and family

disclosure. In addition, through the registry and other funded projects, we hope to gain a better understanding of the genetic-epidemiology of hereditary breast cancer and the efficacy of prevention strategies.

B. Recommendations

- Continue current recruitment of study subjects referred from Georgetown providers and private practice providers, as well as family members of known mutation carriers.
- Continue to increase recruitment of minority subjects.
- Continue cost-effectiveness modeling and utilities analysis.
- The last year of the study will focus primarily on collection of follow-up data and analysis of data regarding psychological and medical implications of BRCA1/2 testing.

PROJECT 2: A COORDINATED APPROACH TO BREAST CANCER DIAGNOSIS

I. INTRODUCTION: This project focuses on developing improved paradigms for breast cancer diagnosis using new methods of imaging and molecular markers of neoplasia measured in nipple aspirate fluid. The ultimate objective of such research is to reduce the number of unnecessary biopsies by improving the specificity and positive predictive value of diagnostic methods.

Currently, there are two parts of the imaging evaluation of women with possible breast cancer. These are called screening and diagnosis. In the first, the patient has a mammogram with two views of each breast obtained and may also have clinical breast examination. If any suspect region is found on the screening mammogram, then the patient proceeds to the second part. In the second part, a radiologist uses those imaging methods that are available to determine whether or not this suspect lesion is real, and whether the positive predictive value is great enough that biopsy is indicated.

Currently, approximately 10% (range 4-14 %) of women having a screening mammogram are called back for diagnostic mammography. In the diagnostic workup, special mammographic views such as compression spot views, magnification views or special mammographic projection views may be obtained. The patient may also have sonography and or breast magnetic resonance imaging with gadolinium. In some centers imaging with ^{99m}Tc Sestamibi may be used. This radiotracer labeled agent, approved by the FDA, localizes in breast cancer and some benign lesions.

After a full diagnostic workup, many patients are excluded from needing biopsy, but approximately 1/3 to 1/4 still need a biopsy. Of those who have a biopsy, 17-32% will have cancer based on the characteristics of the initial suspect region (some findings are more suspicious than others). With some patterns, the likelihood of cancer is close to 100%. But this still means that at least 2/3 of those having biopsy will not have cancer. This project, A Coordinated Approach to Breast Cancer Diagnosis (CABCAD) is designed to establish statistically supported criteria so that some of those women who now have biopsy and who are then found to have only benign disease, could be safely followed without biopsy.

II. BODY: In the CABCAD protocol, women with a suspect lesion identified by screening mammography and/or clinical breast examination and who have had a current standard diagnostic workup with the recommendation of biopsy are recruited into the study. Each woman who agrees is then studied with both advanced imaging methods and with experimental methods. The standard methods are breast MRI with gadolinium enhancement and nuclear scanning with ^{99m}Tc Sestamibi. At the time the study was initiated, Sestamibi was still an experimental agent for breast cancer evaluation. It is now FDA approved. Some of the women had had sonography as part of their standard breast imaging evaluation. The experimental procedures incorporated into the original protocol were digital mammography, and elastography, and (in pre-menopausal women) nipple fluid was aspirated for cytogenetic analysis. In the original protocol, the Sestamibi imaging was imaged with both a standard gamma camera and with a prototype high sensitivity high resolution dedicated breast gamma camera.

Each of these tests was selected because it looks at a different biological spectrum of disease. The digital mammogram looks at anatomy, the sonography looks at tissue texture, the elastography

evaluates hardness, the MRI evaluates microvasculature, the Sestamibi evaluates an unknown factor that is related to p-glycoprotein and mitochondrial localization probably based on molecular charge of the Sestamibi, the nipple aspirate fluid looks at cytogenetic lesions indicating biological change in the epithelium. Of the available imaging studies likely to be useful in this differentiation, only positron emission tomography is not included because its great expense would likely preclude its eventual clinical application for this purpose.

III. PROGRESS: In the first year there was a long delay caused by disagreements between the consent forms as approved by the Georgetown University Institutional Review Board and the US Army Human Subjects requirements. Multiple versions were submitted until we arrived at one form acceptable to both. Project 2, was therefore officially started June 30, 1997. Since that time, we have initiated the protocol and have recruited 186 women into it. In the initial start up phase, scheduling problems were encountered so that not all patients could have all studies. The situation has recently improved, but scheduling problems became very severe in January, 1999 because of increased clinical demand on the MRI system. During much of the first part of this year delays in scheduling were 2-3 weeks, thus many women would have their biopsy prior to any chance of having the MRI. After intense negotiation that started in February, we were (starting in August) able to achieve a weekly 2 hour time slot for breast MRI research on the neural computational science research MRI system and the scheduling problem for MRI has resolved. Recently, there have been cutbacks in technologists available for sestamibi studies making scheduling more difficult, but this has not yet impacted the study. In addition, our clinical coordinator left in June and it has taken several months to fill that position which is now filled. Due to all these problems, we fell somewhat behind schedule, but are now in a catch-up mode. We currently have capability for 3 breast MRI exams a week and two Sestamibi exams per week. We are working to increase the capacity for Sestamibi. At this rate, we will be able to meet the required recruitment needs within the available time for the study. We will be working in this year to increase the recruitment rate slightly so that we are left with six months at the end of the four year project for data analysis.

Table 1 indicates the number of patients recruited into each arm of the study and the biopsy results to date.

Table 1: Biopsy Results of Patients Evaluated

Biopsy Results	No. Patients	Percent
Cancer	20	11
DCIS	8	4
LCIS	3	1
Atypical hyperplasia	7	4
Fibroadenoma	18	10
Other benign	59	32
Results pending	46	25
No biopsy performed in spite of original recommendation for biopsy and biopsy pending	23	13
Total Evaluated	184	100

The goal of this study is to try to find women with suspect lesions requiring biopsy that do not have cancer. Cancer was found in 11% and DCIS in 4% of women going to biopsy. Because the goal is to find features on imaging studies that indicate that the disease is a benign process, we need many benign cases for our analysis and consider this an appropriate ratio of benign to malignant lesions. The patients that have been recruited thus far are representative of the population of women who go for breast biopsy at Georgetown University Medical Center.

For the 184 patients evaluated to date, **Table 2** demonstrates our success in completing the diagnostic studies and the reasons that studies were not conducted.

Table 2: Results of Procedures being Utilized

Procedure	Participants	Comments
Nipple aspirate fluid	12 of 183 (6%)	NAF attempted on 75 patients. Of these, 40 were post-menopausal (only 1 yielded fluid). Of the 35 premenopausal women, 13 had never been pregnant, 3 had had extensive prior breast surgery, 4 yielded no fluid, and 4 yielded insufficient fluid for processing
MRI	104 of 186 (56%)	22 excluded by criteria 5 refused 10 too large 24 not done due to scheduling problems on scanner
Nuclear Sestamibi imaging on Standard Gamma Camera	151 of 186 (81%)	7 refused 8 no available time on machine
Ultrasound	58 of 186 (31%)	Not part of original protocol

Due to continuing scheduling problems, many patients were unable to be scheduled for all studies. The situation should now improve as new approaches are being used in each area. We have encountered sufficient problems with the breast dedicated gamma camera, that we have stopped using it. The updated model that was going to be used to replace the original camera, still has major limitations and the manufacturer has stopped development. The elastography measurements were stopped when the physician developer of this system left Georgetown and took his system with him. Up until the time that he left, he was unable to provide us with interpreted data on the hardness of lesions. Ultrasound examinations as part of this project were discontinued on his departure, but have now resumed.

Some patients are refusing to undergo certain procedures in the protocol. The causes of refusal are being noted as we believe that issues influencing patient unwillingness to have the study will be an

important factor if these methods are determined to be important in the benign/malignant decision. This data is being recorded along with other indices of patient satisfaction with the study, to be used in cost-effectiveness and quality of life analyses conducted in conjunction with the Cancer Clinical and Economic Outcomes Evaluation Core (Core 2).

The low yield in the nipple aspirate studies reflects the large proportion of post-menopausal women, lack of success with women who have not had a prior pregnancy, and continued high refusal rate (52 of 186 patients, 28%). The continued difficulties with scheduling have meant that the clinical coordinator still was often rushed in the procedure. This is critical because experience of other investigators using the NAF procedure suggests that two of the key requirements are for the woman to feel relaxed, and to have sufficient time for adequate milking of the breast. Although we have attempted to obtain fluid from post-menopausal patients, the yield (1 of 40) indicates this is not an appropriate group. Investigators who have had reasonable success rates with this group typically require more time to attempt the aspiration procedure multiple times. As a means of possibly improving our results with the NAF approach, we are planning an in-service in October when we will have a clinical coordinator who conducts NAF sampling in Dr. Susan Love's Breast Clinic. She will show us the procedures they have used, although she has stressed the importance of adequate time.

Findings on imaging studies:

- | | |
|--|--|
| 1. Invasive Breast Cancer: 20 cases. | MRI: Positive in 8, negative in 2. Not done in 10.
Sestambi: Positive in 10, negative in 6, Not done in 4. |
| 2. DCIS : 8 cases. | MRI: Positive in 3, negative in 3, Not done in 2.
Sestamibi: Positive in 5, negative in 2, patient motion in 1. |
| 3. Atypical Ductal Hyperplasia: 7 cases | MRI: Positive in 1, negative in 6
Sestamibi: Positive in 1, negative in 4. Not done in 2. |
| 4. Fibroadenoma: 18 cases | MRI: Positive in 1, benign in 12, not done in 5.
Sestamibi: Positive in 5, negative in 9, not done in 4. |
| 5. Other benign: 59 cases | MRI: Positive in 5, Indeterminate in 2, Benign in 20, 32 not done
Sestamibi: Positive in 9, equivocal in 4, Benign in 17, 29 not done |
| 6. Other small group categories: LCIS 3 cases. Papillomas 7. | |

A. New research information that is relevant to this study

1. Comparative evaluation of conventional vs. digital mammography: We have completed additional prospective evaluation of the digital mammography system that we are using in this protocol. We evaluated this system in a series of 134 cases which included 23 cancer cases. Six

radiologists with no prior experience with digital mammography were, on average, better at distinguishing benign and malignant lesions on the digital images than on conventional high quality original mammograms. This result did not achieve statistical significance with this sample size, but the trend is clearly shown in Table 4. The data has been presented in the SPIE Medical Imaging Conference in February, 1997 and published in their proceedings. An updated analysis was presented at the Third International Conference on Digital Mammography, Nijmegen, Netherlands, June, 1998.

Table 3 demonstrates the average true positive fraction at each false positive fraction for the six readers in a study comparing 24 cancers and 25 lesions that at biopsy were shown to be benign. Digital and conventional images were compared.

Table 3

Reader	#1	#2	#3	#4	#5	#6	Average
Digital	0.600	0.656	0.735	0.697	0.462	0.643	0.633
Screen-film	0.609	0.616	0.556	0.575	0.495	0.644	0.583
p-value	0.923	0.637	0.085	0.069	0.741	0.992	

Table 3 shows the individual ROC areas under the ROC curves for each of the six readers as well as the average of these six values. The digital system is on average, better, but these results do not reach statistical significance with this relatively small sample size.

There have been additional publications on digital mammography performed elsewhere. These articles have all be based on variations of the Storage Phosphor technique that we have been using or an alternate method we demonstrated and reported on in 1993. Findings by Hundertmark, Cowen, Funke, and Perlet agree with our basic findings that this method of digital mammography is equivalent to conventional mammography. An article by Kheddache indicates that the system is not as good as screen film conventional mammography. We have been unable to find any publications of clinical series done with other methods for digital mammography. Non-published information suggests that the three competing systems under test have not shown clinical advantages compared to screen film conventional mammography, but may be equivalent. The FDA recently rejected the application of the Trex Medical digital mammography system as not having been shown to be equivalent to conventional mammography. Because studies done by us and others have shown current technology digital mammography to provide no advantages over high quality conventional mammography, we have discontinued digital mammography acquisition. We are currently performing pilot work under contract with Siemens Corporate Research to determine whether their proprietary image processing of 50 micron pixel digitized mammograms can disclose breast cancer in women in whom the cancers were not mammographically visible. Selected women in CABCAD will be candidates for inclusion in this pilot study if their original mammogram is available, is of high quality, does not show a cancer, and the woman has a cancer that can be precisely localized and sized based on other imaging methods.

2. FDA approval for Sestamibi: At the time of the original grant submission, ^{99m}Tc Sestamibi had not completed evaluation by the FDA for use as a breast cancer imaging agent. This evaluation has now been completed and Sestamibi has received FDA approval for this purpose.

There have been additional studies published comparing the accuracy of breast MRI and Sestamibi. In order for any test or group of tests to meet the requirements for avoiding breast biopsy, very high negative predictive values are necessary. Results reported by Palmedo show a NPV for Sestamibi of 83% and for MRI of 75%. Fenlon reports NPV for Sestamibi of 95% and for MRI of 91%. Helbich reports NPV of 81% for Sestamibi and 98% for MRI. Helbich's results are unusually good for NPV of MRI and less than usually reported for Sestamibi, for uncertain reasons. It is likely that the variability of results reflect different characteristics of the patients included in each study. Because of this, we are recording in our database detailed information about the clinical and mammographic findings in each case. As we analyze our data according to the multiple features recorded in the Breast Imaging Reporting and Data System (BI-RADS) and descriptions of the palpable abnormality, we expect to better define breast lesion characteristics that would indicate those patients in whom MRI and/or Sestamibi would be expected to have sufficiently high NPV to permit follow-up rather than requiring biopsy. The study correlating sestamibi with BIRADS characteristics on the mammogram is currently being analyzed for presentation in Spring, 2000 and publication.

It is clear from the data acquired so far that the choice of an appropriate method for presenting breast biopsies for benign disease will require a careful assessment of the information available from the mammogram and ultrasound. A flow chart of our results is likely to be based on BIRADS criteria and ultrasound descriptors as we do not anticipate a simple answer to the problem. If this effort developing this flow chart is successful, we would then be able to provide a flow chart such that one could say that if one has a mammographic lesion with the following group of BIRADs criteria, then MRI and/or Sestamibi would likely provide the best information to help avoid a biopsy; or alternatively, that for a lesion with those characteristics, neither method would be expected to provide sufficient added information so that biopsy could be avoided. Similar results would also be provided for palpable lesions based on their characteristics.

B. Changes in protocol

1. We have eliminated the experimental test of sono-elastography. In the first year of the protocol, the investigator of this technique was unable to provide us with an interpretation of his data. He has left the institution so that the machine for elastography is no longer available.
2. We have suspended the use of the breast sized dedicated gamma camera because of technical problems in its operation. The inventor of this system had indicated that a new system was being built and would become available. He has now indicated that the newer system will not perform to meet our requirements and that he has stopped development.
3. We are joining in a grant proposal with another investigator (Harry Barrett, PhD, University of Arizona) regarding a differently designed high resolution gamma camera. Should that project be funded (It received a NIH Score of 111), the new experimental camera might become available in the last year of this project. This new small field of view camera has a resolution of 0.2mm, a high enough resolution that the only feature degrading the image would be patient motion and scatter within the breast. Because of its small field of view, accurate positioning would be achieved by ultrasound performed in the Nuclear Medicine facility immediately prior and in the same position used for the Sestamibi imaging.

4. We have added high-resolution ultrasound to the protocol. The investigative work by ATL Corporation has shown that high resolution ultrasound can in some instances provide improved assignment of breast masses into benign and malignant categories. This technology is only recently available to us and we have incorporated it into the protocol. We have also added Doppler measurements of blood flow in breast lesions. Data available from the literature leaves uncertainty as to its benefit in differentiating breast cancer from benign masses. We will be testing the hypothesis that by combining the doppler information with the descriptors of the mammogram and ultrasound findings that this method may provide new information allowing improved differentiation of benign and malignant lesions. In addition to this project, we have started to acquire pilot data to test a new hypothesis: In a woman with an identified breast cancer, the concern is that there may be a second primary cancer or that the extent of the cancer may be larger than that identified by mammography. MRI has been recommended as a method for better defining the extent of tumor and the presence of second primary lesions. As a pilot project we will be comparing whole breast ultrasound to MRI for the measurement of the extent of tumor and for the presence of second primaries.

5. Other technologies under investigation: We are in discussions with TransScan Medical (Ramsey, NJ), a company that has developed a method to record electrical activity from the breast and from breast cancer. Data acquired by TransScan recently led to FDA approval of this device for improving the decision between BIRADS 3 and low grade BIRADS 4 lesions. During this past summer, we had the machine at Georgetown and did extensive tests of it related to electronic reliability and to develop a phantom to better understand how it works. We found that the machine could indeed detect both benign and malignant lesions in the breast, but that the electrical reliability of the machine's measurements were different from actual electrical values input into the machine and varied under different test situations. The company has offered us 24 months use of the updated model of the machine for incorporation into this project. Once confirmed with a written contract, TransScan will be incorporated into this project. The data submitted to the FDA indicated that the combination of TransScan with Mammography increases the specificity of mammography and that this effect is greatest in women under the age of 50. It is therefore a good fit for inclusion in this project.

Tables 4 and 5: Data submitted by TransScan to the FDA in the Approval Process. TransScan received FDA approval June, 1999.

	Sensitivity	Specificity
TransScan Alone	69%	45%
Mammography alone	82%	39%
TransScan and Mammography	86%	51%

	Sensitivity	Specificity
Under 50 yrs	81%	76%
Over 50 yrs	76%	66%

Dr Freedman is working with Genex Technologies, Kensington, MD, as a consultant to their SBIR in the development of a method for recording tactile information from the breast. The system is currently capable of detecting the inclusions in breast palpation training phantoms, but it is unclear at this time

how much characterization of the lumps will be possible. The phase 2 SBIR application has been filed and if funded, research on this system will continue.

6. We are providing data from the breast MRIs obtained as part of this study to our research partners at Catholic University: Joseph Wang, PhD and his PhD student Kelvin Wood for their work on a US Army funded project to improve the visualization of breast cancer on breast MRI examinations through 3D visualization methods and change detection.

C. Changes in Personnel: Miriam Mullins, the Research Coordinator submitted her resignation in June, 1999, after completion of her Nursing studies. After a careful search, Anita Sarcone, RT, a senior Sonographer with extensive research experience was recruited as her successor. This has allowed us to incorporate new ultrasound methods into the protocol at no additional charge for imaging studies. She will be learning breast MRI to solve the problem of technologist availability for breast MRI. Susan Ascher, MD, who was previously responsible for the Breast MRI portion of this project, has moved on to other research activities and has been replaced by Matthew Freedman, MD.

D. Clinical and Economic Outcomes: We are collecting information on patient satisfaction, test acceptability, and costs using materials developed by Core 2.

E. Data acquisition and analysis: We are recording data as acquired. We perform routine demographic analysis of the study. Because of the small number of cases to data, we have not yet performed a statistical analysis of the imaging features being found.

IV. CONCLUSIONS: Project 2, A Coordinated Approach to Breast Cancer Diagnosis is actively recruiting patients and is gathering data on patients with both benign and malignant disease. We have encountered significant scheduling problems based on cutbacks in Medical Center technical personnel and equipment availability. We are progressively addressing these problems and have at least partial solutions to them that should allow us adequate availability for this study. The previous clinical coordinator has resigned and after a delay, an excellent replacement has been found. The results of the correlation of Sestamibi with mammographic BIRADS categories are being analyzed and are being prepared for presentation and publication. We have added high resolution ultrasound and doppler measurements to our protocol and are exploring as a pilot project its substitution for MRI for the detection of second breast primary tumors and measurements of disease extent. We have changed several aspects of the protocol based on new knowledge. For the MRI evaluation we have changed to a high resolution single breast technique. We have modified the ROC statistical design to reflect the change to an evaluation of the involved breast only. We have eliminated the acquisition of digital mammography having shown that it provided no new information. We are, however, studying the potential benefit of image processing of digitized mammography for the detection of breast cancers not visible on conventional mammography. We are working to acquire a new supplier of a high resolution gamma camera for breast Sestamibi studies. Overall, the project is proceeding adequately, providing data that we expect will provide a flow chart for the work-up of suspect lesions in the breast based on categorization by BIRADS and ultrasound descriptors.

V. REFERENCES

- American College of Radiology Breast Imaging Reporting and Data System (BIRADS). American College of Radiology, Reston VA 1993
- Cowen AR, Launders JH, Jadav M, et al. Visibility of microcalcifications in computed and screen-film mammography *Phys Med Biol* 1997. 42: 1533-1548 (only abstract reviewed)
- Fenlon HM, Phelan NC, O'Sullivan P, et al. Benign versus malignant breast disease: comparison of contrast enhanced MR imaging and Tc-99m tetrofosm scintimammography. *Radiology* 1997; 205:214-220
- Freedman M, Steller Artz D, Hogge J, Zuurbier RA, Jafroudi H, Lo S-CB, Mun SK. An ROC Study of Screen Film Mammography and Storage Phosphor Digital Mammography: Analysis of Non-Concordant Classifications. Implications for the approval of digital mammography systems. *Proc. SPIE Medical Imaging 1997*. Harold Kundel Editor. 3606:281-291
- Funke M, Breiter N, Hermann KP, et al. Storage phosphor direct magnification mammography in comparison with conventional screen-film mammography—a phantom study. *Br. J. Radiol* 1998; 71: 528-534. (only abstract reviewed).
- Haddad B, McCormack S, Young H, Trock B, et al. Molecular cytogenetic screening of epithelial breast cells in nipple aspirate fluid by comparative genomic hybridization. *Proc Amer Assoc Cancer Res* 1998; 39:334-335.
- Helbich TH, Becherer A, Trattnig S, et al. Differentiation of benign and malignant breast lesions: MR imaging versus Tc-99m sestamibi scintimammography. *Radiology* 1997; 202:421-429.
- Hundertmark C, Breiter N, Hermann KP, et al. Digital magnification mammography in computed radiography. Initial clinical results. *Radiologie* 1997; 37:597-603. (Only English language abstract reviewed)
- Kallioniemi OP, Kallioniemi A, Sudar D, et al. Comparative genomic hybridization for molecular cytogenetic analysis of solid tumors. *Science* 1992; 258:818-821.
- Kheddache S, Kvist H, Digital mammography using storage phosphor plate technique—optimizing image processing parameters for the visibility of lesions and anatomy. *Eur J Radiology* 1997. 24:237, 244. (only abstract available)
- Kuhl CK, Bieling H, Gieseke J et al. Breast neoplasms: T2* Susceptibility-contrast first pass perfusion MR imaging. *Radiology* 1997; 202:87-95
- Palmedo H, Grunwald F, Bender H, et al. Scintimammography with technetium-99m methoxyisobutylisonitrile: comparison with mammography and magnetic resonance imaging. *Eur J Nucl Med* 1996, 23: 940-946

Perlet C, Becker C, Sittek H et al. A comparison of digital luminescence mammography and conventional film-screen system: preliminary results of clinical evaluation. *Eur J Med Res* 1998 3:165-171. (only abstract available)

Roebuck JR, Cecil KM, Schnall MD et al. Human breast lesions: Characterization with Proton MR Spectroscopy. *Radiology* 1998; 209: 269-275

Vecchio SD, Ciarmiello A, Pace L, et al. Fractional retention of technetium-99m-sestamibi as an index of p-glycoprotein expression in untreated breast cancer patients. *J Nuclear Medicine* 1997. 38:1348-1351

Paper arising from MRI data: Lawrence WF, Liang W, Mandelblatt JS, Gold KF, Freedman M, Ascher SM, **Trock BJ**, Chang P Serendipity in diagnostic imaging: magnetic resonance imaging of the breast. *J Natl Cancer Inst* 1998;90:1792-800.

PROJECT 3: DEVELOPMENT OF NOVEL ANTIANGIOGENIC THERAPIES IN METASTATIC BREAST CANCER

I. INTRODUCTION: The overall purpose of this proposal is to evaluate the clinical benefits of inhibitors of angiogenesis in regards to improving the care of patients with breast cancer. We are complementing these clinical trials with studies of the quality of life of participating patients, as well as with studies of the cost effectiveness of application of these agents in comparison to standard care. As described in our original proposal, several possible angiogenic inhibitors are available for study. We selected two of these agents for our studies: the fumagillin derivative, TNP-470; and the sedative, thalidomide. Both had been shown to have anti-neovascular and anti-neoplastic properties in preclinical studies, and phase I studies of these drugs were either completed or underway at the time of our original proposal.

Clinical trials directed toward accomplishment of our goals and aims are now nearly complete. We have completed a Phase II study of thalidomide and reported the preliminary results at a national meeting, and a manuscript describing the final results is being prepared. Patient accrual to a Phase I pilot study of TNP-470 in combination with paclitaxel is complete, and followup of participating patients is ongoing. We are now considering whether our preliminary results justify a phase III trial in which paclitaxel plus TNP470 will be compared to paclitaxel alone. The following sections will describe our progress to date, as well as problems we have encountered and the actions we have taken to resolve them.

II. BODY

A. HYPOTHESIS/PURPOSE: We hypothesize that incorporation of well-tolerated antiangiogenic agents into standard treatment regimens for breast cancer will increase progression free survival, improve quality of life and, due to fewer treatment related side effects, decrease health care costs. Because these agents are unlikely to result in objective, measurable tumor regressions, we feel it is necessary to develop innovative trial designs to document their efficacy.

B. TECHNICAL OBJECTIVES: These objectives were to be met by a collaboration between the clinical investigators in Project 3 and the investigators from the Quality of Life and Clinical Economics Core. This section of the Annual Report will only cover Technical Objective 1. The other two will be covered in the Report describing the results from the Core.

- 1.** To evaluate the antitumor activity of novel, non-cytotoxic antiangiogenic agents for the treatment of metastatic breast cancer in Phase II and Phase III trials. These studies will increase the availability of investigational agents to minority and under served patient populations with metastatic breast cancer.
- 2.** To evaluate the impact on quality of life of non-cytotoxic antiangiogenic agents in a diverse spectrum of patients with metastatic breast cancer.
- 3.** To evaluate the cost-effectiveness of non-cytotoxic antiangiogenic agents in patients with metastatic breast cancer.

C. OVERVIEW OF CLINICAL TRIALS OF ANTI-ANGIOGENESIS: In our initial proposal, we planned two separate clinical trials of anti-angiogenic agents. In the first, we proposed to test the activity of the angiogenic inhibitor, TNP-470, using a novel trial design. In a second study, we proposed to test the efficacy of oral thalidomide, in a randomized phase II clinical trial. After some initial adjustments in trial design, we have now we have completed accrual to a Phase I study of the combination of weekly paclitaxel plus TNP470, and we have completed a Phase II trial of thalidomide trial. The pre-clinical data and rationale for these studies was fully presented in our update last year. The following sections review our progress in these two studies, to date.

Figure 1 illustrates our current clinical trial plan:

Year/Month	1998			1999								2000				
	10	11	12	1	2	3	4	5	6	7	8	9	10	11	12	1..
Thalidomide		Abstract Presented at American Society of Clinical Oncology, Atlanta, GA, May 1999						Manuscript being prepared describing clinical, pharmacokinetic, and correlative science results			Submit Data for Publication					
TNP/Paclitaxel Pilot		Clinical Phase I trial opened and fully accrued									Ongoing patient followup	Submit results to national meeting for presentation				
Randomized Trial	Re-considering initiation of prospective randomized trial of weekly paclitaxel plus TNP470, given results of Phase I trial and correlative science suggesting lack of synergistic or additive clinical or anti-angiogenic activity.															

1.0 Studies of TNP470 and paclitaxel. In a previous report, we provided evidence that the combination of TNP470 and paclitaxel is of interest. Prior Phase I studies with TNP470 alone demonstrated that the plasma half life of TNP470 is very short. Preclinical evidence suggests that paclitaxel might prolong the half-life of TNP470, presumably by reducing hepatic clearance. Moreover, paclitaxel alone has demonstrated anti-angiogenic activity. Finally, recent studies from other sites have demonstrated that paclitaxel can be administered weekly with an excellent safety profile.

Revised Research Plans. Taken together, these results suggested that the combination of paclitaxel and TNP-470 might result in both direct tumor cell cytotoxicity due to the paclitaxel and, more germane to this proposal, to additive and perhaps synergistic suppression of angiogenesis due to both drugs. However, the precise dose, schedule and toxicities of combining these two agents have not been determined.

We therefore proposed to delay initiation of a randomized trial while we performed a pilot phase I clinical study to determine whether weekly administration of paclitaxel, coupled with simultaneous TNP-470, is safe, and to determine the MTD of TNP470 when delivered in combination with paclitaxel. The endpoints we will use to make this decision include pharmacokinetics (TNP-470 levels), toxicities, convenience of drug delivery, and overall cost of administration.

As proposed in our last update, the pilot trial of weekly paclitaxel and TNP470 was performed in patients with any metastatic malignancy that is refractory to standard therapy or for whom paclitaxel would be considered appropriate therapy. However, we preferentially placed any patient with breast cancer for whom paclitaxel was a reasonable treatment option on this Phase I trial. We chose this strategy for the following reasons: 1) there is no reason to believe that the toxicities and pharmacokinetics observed in patients with other solid tumors would not be applicable to patients with breast cancer; 2) paclitaxel is active in many malignancies, and the schedule to be tested is novel and may have even greater activity than that used in the standard clinical setting; and 3) wider eligibility hastened our ability to complete this pilot and move on with the breast cancer-specific randomized trial.

We are now considering a randomized trial comparing paclitaxel vs. paclitaxel plus TNP-470 in patients with metastatic breast cancer, using the paclitaxel and TNP470 dose and schedule selected from the pilot. However, in the interest of patient concern, we have not proceeded with this trial due to the relative lack of apparent enhanced efficacy of the combination of paclitaxel and TNP470 as it was delivered in this Phase I trial.

We are requesting ongoing support as previously awarded to complete followup of patients on the Phase I trial, and to complete analysis of the results. The trial was partially supported by TAP Pharmaceuticals. However, the research nurse supported by the DOD is actively participating in regards to the quality of life and cost effectiveness analyses, which are not funded by TAP. Therefore, data management and other responsibilities of the research nurse, including QOL and CEA will be entirely supported by DOD funds.

Clinical Trial Results: Pilot Trial of Paclitaxel and TNP-470 II. Weekly 1 hr Infusion Paclitaxel plus TNP-470. In anticipation of initiating a prospective randomized trial of paclitaxel with or without TNP-470, we performed a Phase I study of the optimal dose of this combination of drugs, using a relatively novel schedule. We simultaneously studied circulating anti-angiogenic activity in serum of patients receiving this combination.

Eligible patients who signed the consent form were administered TNP 470 as a 4-hour infusion on day 1. Paclitaxel was administered starting on day 8 as a 1-hour infusion, followed by TNP-470 as a 4-hour infusion. The second and subsequent cycles were administered at 1 week intervals from the first day of Paclitaxel infusion. For each cycle, Paclitaxel was administered as a 1 hour infusion with TNP-470 given as a 4-hour infusion on the same day as Paclitaxel treatment. All treatment was done on an outpatient basis.

Figure 2. Treatment Plan for paclitaxel plus TNP-470.

	First Cycle					Subsequent Cycles			
	D1	D8	D15	D22	D29	D1	D8	D15	D22
TNP-470	X	X	X	X		X	X	X	
Paclitaxel		X	X	X		X	X	X	

Progress to Date: As of September 15, 1999, 22 patients have entered into this Phase I trial. Patient characteristics are provided in Table 1.

Table 1. Characteristics of patients entered onto Phase I trial of paclitaxel + TNP-470.

Dose Level	Disease	Gender	Age	Race
I	Cervical Cancer	F	49	Caucasian
	Anal Cancer	M	52	Caucasian
	Cancer of Unknown Origin	M	50	Caucasian
II	Ovarian Cancer	F	43	Hispanic
	Breast Cancer	F	44	Caucasian
	Breast Cancer	F	75	Caucasian
III	Breast Cancer	F	64	Caucasian
	Lung Cancer	F	52	Caucasian
	Mesothelioma	M	66	Caucasian
IV	Lung Cancer	F	66	Caucasian
	Carcinoid Tumor	M	36	Asian
	Prostate Cancer	M	52	Caucasian
	Ovarian Cancer	F	56	Caucasian
	Cervical Cancer	F	43	Caucasian
	Breast Cancer	F	45	Caucasian
	Cancer of Unknown origin	M	51	Caucasian
	Soft Tissue Sarcoma	M	71	Caucasian
V	Lung Cancer	F	54	Caucasian
	Cholangiocarcinoma	F	74	Caucasian
	Lung Cancer	F	34	Caucasian
VI	Ovarian Cancer	F	54	Caucasian
	Lung Cancer	M	52	Hispanic

Toxicities: Toxicity data are available for patients enrolled in Dose Levels 1-4 and are summarized in Table 3. Predominant toxicities consisted of fatigue (mild), nausea/vomiting, diarrhea, hair loss and myelosuppression believed to be due to Paclitaxel. One patient on dose level 3 and two patients on dose level 4 developed peripheral neuropathy attributable to Paclitaxel. One of these patients (on dose level 4) required reduction in the dose of Paclitaxel. Dose level 4 was therefore expanded to include a total of 6 evaluable patients. One patient on dose level 3 developed ocular scotomas shortly following drug infusion. This patient was removed from study due to recurrence of scotomas on re-treatment. Since ocular scotomas have been previously reported with Paclitaxel, this toxicity was felt to be attributable to Paclitaxel. One patient each on dose levels 1 and 3 developed lightheadedness/dizziness, and one patient on dose level 4 developed decreased memory and difficulty finding words. Such toxicities have been previously observed with TNP-470 treatments. Toxicity data on patients on dose levels 5 and 6 is currently being collected.

Table 3. Toxicities for patients enrolled in Phase I trial of paclitaxel and TNP-470.

Toxicity	Dose Level					
	1 TNP-470 (88.5) Taxol (70)	2 TNP-470 (88.5) Taxol (80)	3 TNP-470 (133) Taxol (80)	4 TNP-470 (133) Taxol (90)	5 TNP-470 (177) Taxol (90)	6 TNP-470 (177) Taxol (100)
Nausea/Vomiting	1	0	0	3	Data	Data
Diarrhea	0	0	1	2	Being	Being
Fatigue	1	2	2	3	Collected	Collected
Anorexia	0	0	0	2		
Mucositis	1	0	0	0		
Leukopenia	1	0	0	2		
Anemia	1	1	1	0		
Thrombocytopenia	1	0	0	0		
Lightheadedness/ Dizziness	1	0	1	0		
Myalgia	0	1	0	1		
Depression	0	1	2	0		
Hair Loss	0	0	0	1		
Peripheral Neuropathy	0	0	1	2		
Ocular Scotomas	0	0	1	0		
Decreased Memory	0	0	0	1		
Difficulty Finding Words	0	0	0	1		

Pharmacokinetics: Serial plasma samples have been collected from these patients. Plasma pharmacokinetics of TNP-470 are being performed by TAP pharmaceuticals. Plasma pharmacokinetics of paclitaxel will be performed at the bioanalytical laboratory at Georgetown University. These studies are underway, and they will be reported in our next Annual Report.

Biologic Assay for Anti-angiogenic Activity in Plasma: An endothelial cell proliferation assay is being utilized to study the biologic activity of this drug combination. Preliminary data indicate that paclitaxel and TNP-470 may have additive anti-angiogenic activity. Sample analysis is ongoing at this time. Final results will be reported in our next Annual Report.

Summary of TNP-470 Pilot Studies. In summary, preclinical data suggest that the combination of paclitaxel and TNP-470 might be additive if not synergistic as a result of prolonged half-life of TNP-470 and additive anti-angiogenic activities. We performed this pilot, Phase I study to determine if the combination of the two drugs, delivered weekly, was tolerable, and to determine the MTD. In that regard, toxicity data collected thus far show that the combination of TNP-470 and paclitaxel is well tolerated up to a dose of 133 mg/m² of TNP-470 and 90 mg/m² of paclitaxel. The DLT is peripheral neuropathy.

We are now considering whether to proceed to a prospective randomized trial. Although the phase I trial was not performed to determine efficacy, our overall impression was that the combination did not

result in substantially higher response rates than we might have expected in this population. However, because this was a phase I study with a very heterogenous group of patients, many of whom were heavily pre-treated, we cannot say that the combination is not sufficiently exciting to proceed. Therefore, we continue to plan to use the pharmacokinetic and correlative science data to guide our decision to mount an expensive phase III study.

Pharmacokinetic analysis will reveal if paclitaxel has any effect on the half-life of TNP-470. Preliminary data from the biologic assay of a few patients suggest an additive anti-angiogenic effect of this drug combination. However, further analysis of collected samples is required to confirm this observation.

Of note, based on results of this study and a second phase I study of TNP-470, we are now considering a modification of this trial design. An ongoing phase I trial at our institution is evaluating TNP-470 given by a continuous 120-hour infusion. Future plans include exploring the possibility of combining weekly paclitaxel with a 120-hour infusion of TNP-470. This trial would be a limited study of 10 patients to determine the toxicities of continuous infusion TNP-470 over 120 hours, using the MTD established in the ongoing phase I, with weekly paclitaxel. We anticipate that this study will open in Spring, 2000, pending completion of the ongoing Phase I continuous infusion and the pharmacokinetic and biologic assays from the recently closed Pilot Phase I study of weekly paclitaxel plus TNP-470.2.

2.0 Phase II Clinical Trial of Thalidomide with Pharmacologic and Growth Factor Monitoring. Overview. As described in our initial proposal, the sedative thalidomide has been shown to have potent anti-angiogenic activity in preclinical models. Indeed, it has recently been approved for clinical use in this country for non-neoplastic diseases, with the caveats necessary to avoid exposure to pregnant women.

We therefore chose to pursue a randomized Phase II study of thalidomide in patients with breast cancer. We have now fully completed accrual and follow up of patients on this trial. We reported the clinical results in our last Annual Report, and they were presented in abstract form at the American Society of Clinical Oncology Annual Meeting in May, 1999 (Atlanta GA). The following is a progress report of the clinical and correlative science aspects of this study. The QOL, and cost studies are not yet sufficiently mature to report.

Phase II Evaluation of Thalidomide in Patients with Metastatic Breast Cancer Patients accrued to Thalidomide: Twenty eight patients were been accrued at the four centers (Table 4). Fourteen patients were accrued on each of the two dose levels. All patients were women with metastatic breast cancer (24 Caucasian, 3 African American, 1 Hispanic).

Dose	Georgetown	Dana Farber	Chicago	Duke	Total
200mg	6	4	3	1	14
800mg	9	3	2	0	14
Total	15	7	5	1	28

Patient Characteristics

Characteristic	200mg	800mg
Age		
30-40	1	3
41-50	7	2
51-60	5	4
61-70	0	4
71-85	1	1
Prior Chemotherapy regimens		
0-1	2	2
2-3	12	12
ABMT	3	2
Number of Hormonal Therapy		
0-1	7	5
2-4	7	9
Site of Disease		
Bone Only	1	0
LN only	3	1
Liver Only	1	1
Chest Wall	1	0
2-4	8	12

Patient Outcome and Dose modifications: All patients have been removed from the study due to progressive disease except two patients. The first was removed due to grade 3 peripheral neuropathy and the second refused to continue treatment on study due to mild side effects (refused dose reduction). One patient at the 200mg dose required dose reduction due to grade 3 neuropathy. At the 800mg dose, four patients had to reduce dose to 600mg and two patients to 400mg, all due to neurotoxicity (somnolence). Three patients continued at the 800mg dose with no changes.

Duration of treatment: At the 200mg level, one patient was taken off study at 2 weeks and a second patient at 4 weeks from starting treatment due to progressive disease. Ten patients were taken off at 8 weeks due to progressive disease at the time of staging. Two patients went beyond the first 8 weeks staging, one was removed from study at 11 weeks due to G3 neuropathy and the second at 16 weeks due to progressive disease at the time of staging.

At the 800mg level, two patients were removed from study at 4 weeks, one due to progressive disease and the second refused to continue treatment due to side effects (also, refused dose reduction). For patients were taken off study at six weeks due to progressive disease and eight patients were taken off at 8 weeks due to progressive disease. None of the patients at the 800mg continued beyond the first eight weeks of treatment.

Adverse Events: Only one patient was removed from the study due to grade 3 neurotoxicity (peripheral neuropathy). This patient was on the 200mg dose and was removed at week 11. The main dose limiting toxicity was somnolence (grade 2) requiring dose reduction at the 800mg dose level. The dose was reduced from 800 mg to 600mg for four patients, and from 800 mg to 400mg dose for two patients. The other adverse events did not require dose reduction or removal from the study.

Adverse Event	Number of Patients Treated at:		Total
	200mg	800mg	
Constipation	3	10	13
Somnolence	4	8	12
Fatigue	6	6	12
Peripheral neuropathy	5	4	9
Dizziness and Instability	2	4	6
Dry Mouth	2	6	8
Skin rash	1	2	3
Nausea	0	2	2
Anorexia	1	1	2
Arrhythmia	1	0	1
Neutropenia	1	1	2
Headaches	1	0	1

Efficacy/Response to Treatment: Response: No patient achieved partial or complete response.

Time to Treatment Failure/Progression. In addition to determining response, we also prospectively assessed evidence of failure to progress at eight weeks, with the assumption that to do so in a group of patients with previously progressive disease would indicate activity of the drug. Two patients at the 200mg dose had stable disease at the 8 weeks staging. The first patient had reduction in the hilar and mediastinal lymphadenopathy (only site of disease) by 47% at the 8 weeks staging. However, at the 16 weeks staging, she had progressive disease at that site and was removed from the study. The second patient had chest wall disease that was slowly progressing on no treatment over the last twenty months before starting thalidomide. At the 8 weeks staging she had stable disease, she was removed from the study at week 11 due to grade 3 peripheral neuropathy.

Thirteen patients at the 800mg dose had progressive disease at 8 weeks or before, and none went beyond the first 8 weeks. One patient refused to continue treatment beyond week 4 due to side effects and refused dose reduction

Correlative Science: Circulating Angiogenic Factor Levels. At base line, five of 27 (18.5%), six of 27 (22.2%), and 13 of 27 (48.1%) patients had elevated levels (\geq mean + 1SD in normal population) of bFGF, VEGF, and TNF- α respectively. Serial bi-weekly changes in serum bFGF, VEGF, TNF- α and MMP-9 are illustrated in Figure 1. Patients were only included in this analysis if their marker levels were elevated at some point (baseline or follow up). Non-informative patients (patients whose marker levels were never above a cut off of the mean +1 SD of a normal population) were not included. A change of 25% or more from baseline to follow-up was considered to represent a real (biologic) difference. Changes in circulating bFGF and VEGF levels appeared random and no describable, consistent pattern could not identified. In contrast, TNF- α levels increased by \geq 25% in 14 of 21 (67%) informative patients from baseline to week 2. Furthermore, several TNF- α levels continued to increase

in several patients. Fourteen of 20 (70%) patients had rising TNF- α levels by $\geq 25\%$ and no one had decreased levels by $\geq 25\%$ from baseline to week 4.

Figure 1. TNF-alpha Levels During Thalidomide Treatment. Open Circles=800 mg/day. Closed Circles= 200 mg/day. X=Uninformative Patients (TNF=alpha levels never above normal cutoff).

Of note, the only patient who did not have rising TNF- α levels was the single patient that experienced a near partial response. The precise significance of this observation, if any, is unclear. Pharmacokinetic data are still being analyzed.

Thalidomide Trial: Summary. We conclude that thalidomide at 800 mg/day had no detectable activity in this setting. Furthermore, it was only moderately tolerable, mostly due to somnolence and other neurotoxicities. According to our prospectively written criteria, at least one patient, and perhaps two, failed to progress at 8 weeks on the lower dose. Therefore, thalidomide may have some activity in patients with metastatic breast cancer, but it must be considered minimal, at best. We have elected not to proceed with further accrual, since our conclusion is that the activity of thalidomide in this patient population, if it exists, is too small to justify ongoing administration to patients. The only discernable trend in angiogenic growth factors was a consistent rise in TNF- α levels after treatment, which, incidentally, was not observed in the single patient who experienced a near partial response. Otherwise, the results of angiogenesis assays failed to provide any real insight into why thalidomide

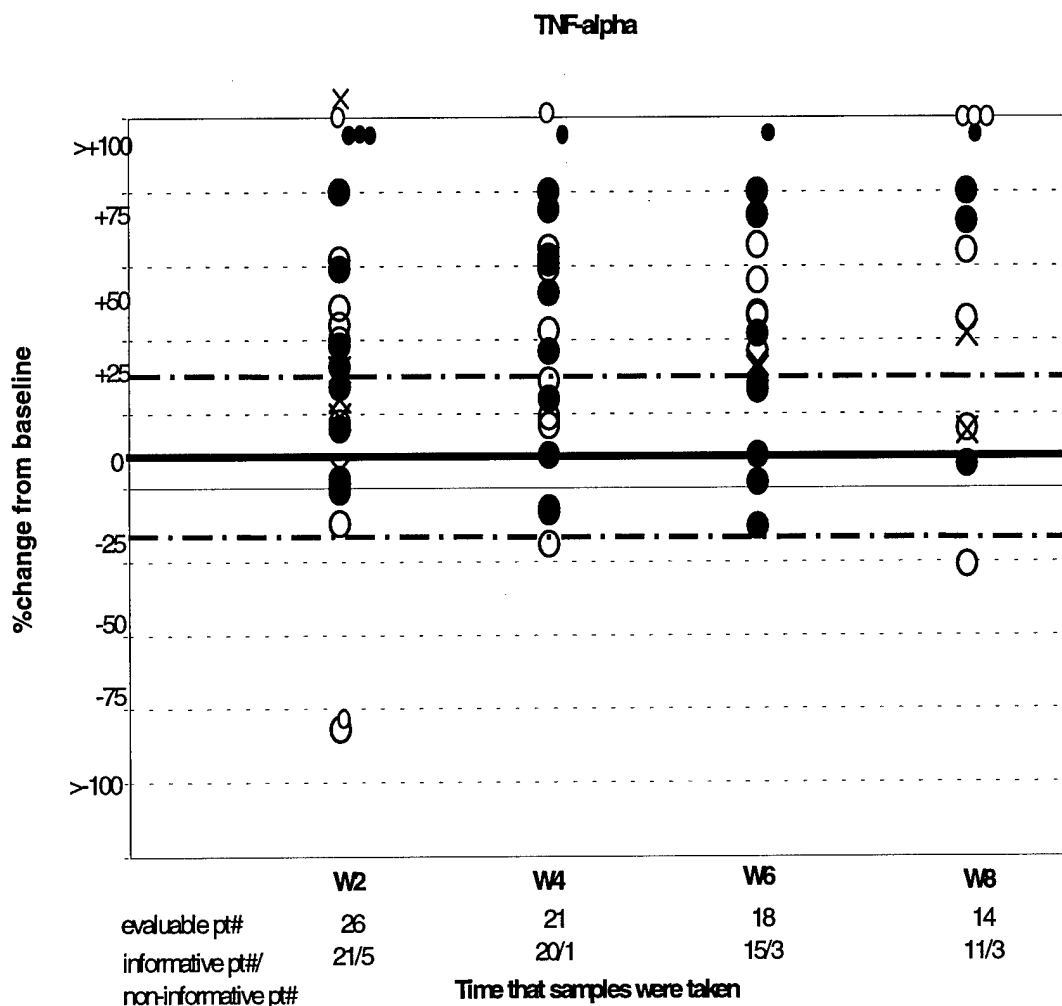

was not more active against metastatic breast cancer in this setting. Circulating levels of thalidomide are now being determined to be certain that the pharmacokinetics in this population are not different from those in the normal population. However, it seems unlikely, since drowsiness was observed as expected, and toxicities were greater in the 800 mg/day arm, suggesting that adequate drug levels were achieved. Pilot QOL and cost analyses will be discussed in the Core sections of this Report.

III. KEY RESEARCH ACCOMPLISHMENTS

- Completed Phase I study of TNP-470 plus paclitaxel
- Completed Phase II study of thalidomide

IV. REPORTABLE OUTCOMES (1, 2)

- Baidas S, Isaacs C, Crawford J, Winer E, Fleming G, Harris L, Pluda J, Hawkins M, Lippman L and Hayes DF. A phase II evaluation of thalidomide in patients with metastatic breast cancer. Proceedings of the American Society of Clinical Oncology. 1999; 18:125a. (see Appendix)
- Baidas S, Winer E, Fleming G, Harris L, Pluda J, Crawford J, Isaacs C, Hanfelt J, Flockhart D, Johnson M, Yamauchi H, Hawkins M, Lippman M and Hayes DF. A phase II evaluation of thalidomide in patients with metastatic breast cancer. in preparation

V. OVERALL SUMMARY: As stated, the overall goals of this project are to evaluate the effects of angiogenic inhibitors in prospective clinical trials in patients with breast cancer. We have now successfully completed a randomized phase I/II study of thalidomide, which has provided insights into the relative lack of activity high dose (800-1200 mg) and standard dose (200 mg) thalidomide.

Furthermore, we have finished a Phase I trial that has provided more information regarding our proposal to conduct a randomized trial regarding whether TNP-470 contributes added benefit to the chemotherapeutic agent, paclitaxel.

Although thus far we have failed to observe an apparent efficacy benefit with either of these strategies, these data are of critical importance to the research community. The hypothesis that angiogenesis inhibition will be an effective treatment for cancer continues to be highly controversial, both in the lay and scientific press. Our results suggest that, at least, thalidomide as a single agent is not an effective treatment for metastatic breast cancer. Our study also provides tolerability data for investigators who might wish to pursue high dose thalidomide. These observations may be useful if thalidomide is to be studied either in combination with other agents or in other diseases, such as Kaposi's sarcoma and multiple myeloma, in which some activity has now been reported.

We continue to maintain an interest in TNP 470 and, ultimately and if justified, a randomized trial of this agent with paclitaxel. TNP 470 has remarkable anti-angiogenic activity in pre-clinical models. Rather than conclude that it is not active clinically, we await pharmacokinetic data to determine if drug levels are unfavorable unless TNP-470 is delivered over long periods of time or very frequently. A phase I trial of TNP 470 delivered as a continuous infusion over 5 days is now ongoing at Lombardi.

After completion of this trial, we are considering another phase I trial of the combination of this agent as a continuous infusion with weekly paclitaxol. If the results of that phase I trial are promising, then we will pursue the prospective randomized clinical trial of paclitaxel, with or without TNP 470.

VI. APPENDIX (included in full packet following annual report text)

Appendix 1: Abstract - A PHASE II EVALUATION OF THALIDOMIDE IN PATIENTS WITH METASTATIC BREAST CANCER.

CORE 1: PATIENT ACCESSION CORE

I. INTRODUCTION: The overall goal of the Patient Accession Core (PAC) has been to promote and facilitate increased participation, in current and proposed Lombardi Cancer Center Breast Center research protocols, by patients and high-risk women who have historically had difficulty accessing and benefiting from cancer prevention, diagnostic and treatment trials. Two particular groups of patients and high-risk women have been the focus of these outreach efforts: 1) medically underserved populations, particularly African-American and elderly patients and 2) high-risk individuals who are members of health maintenance organizations (HMOs).

The following is an account of the Year 3 efforts directed toward meeting the objectives specified for the Patient Accession Core of the Department of Defense-funded Breast Cancer Research Center of the Lombardi Cancer Center. As noted in last year's progress report, the PAC has been engaged in activities different from those specified in the original proposal. As such, these are described within the discussion of original objectives or in the conclusion of this section. The specific aims of the proposed PAC have been as follows:

- **Expand Lombardi's established links with the community-based Washington D.C. organizations and primary care clinics already serving the needs of the area's medically underserved.** This was done by forming a Community Advisory Board and a Clinic Advisory Board to the Lombardi Breast Cancer Research Center in order to review community-based education, protocol promotion, clinical referral, and patient transportation mechanisms. Our limited minority accrual experience in the first two years of the PAC caused us to modify this approach and subcontract with a social marketing firm (Matthews Media Group) to promote participation in the DOD-funded CARE study, and to a lesser extent the CABCAD study.
- **Expand Lombardi's links with local and national Health Maintenance Organizations (HMO) serving the greater Washington D.C. area.** This was done by forming an HMO advisory board to the Lombardi Breast Cancer Center to review HMO member education, protocol promotion and clinical referral mechanisms and to participate in evaluating cost-effectiveness data from HMO members participating in breast cancer diagnosis and treatment trials at the Lombardi Center. Based on rapid and repeated turnover of Managed Care Organization leadership, making it difficult to negotiate referral arrangements, in the 03-year we began to focus on HMO's with a larger medically underserved patient population.
- **Expand Lombardi's existing breast cancer education materials and health promotion programs** by making them available through the information superhighway (e.g. the Internet) for HMO members and by basing these materials and programs in medically underserved community settings. All LCC protocols are being posted on our Website, and MMG developed CARE promotion materials that were disseminated through primary care clinics, HMO's and community organizations.
- **Provide cultural awareness and sensitivity training to Lombardi Breast Cancer Center clinicians** involved with prevention, diagnostic and treatment research protocols to ensure

supportive patient care for all patients on clinical trials. Two training sessions were held in the 02-year.

- **Provide free transportation**, with the Lombardi Cancer Center van, for medically underserved patients for whom transportation to, and/or parking in, Georgetown may represent a barrier. Accrual has been so limited that this issues ahs not arisen.

II. PROGRESS REPORT 1998-1999

A. Community Outreach Initiatives

Community Advisory Board (CAB): During Year III, the Community Advisory Board was not reconvened, based on the lack of referrals being generated by member organizations during the first two years. During the two meetings held in Year II, CAB members were alerted that the PAC would be contracting with an independent company to support the patient recruitment efforts for clinical research. Lenora Johnson, the PAC coordinator, solicited potential candidates for the contract at that time. CAB members were also informed of the PAC plans to offer training workshops in cultural awareness and sensitivity to LCC staff members working with patients in clinical trials. An overview of the training workshop was shared with members of the CAB.

Primary Care Clinic Advisory Board: Just as with the CAB, the Primary Care Clinic Advisory Board was not reconvened during Year III. For community-based primary clinics there have been two paramount challenges to recruitment. The first was our inability to provide services to Spanish speaking populations (two of the clinics on the board provide health services to Hispanic communities) and the second was developing efficient referral methods for clinic clinicians.

In response to the concern for meeting the needs of Hispanics, PAC worked with Dr. Caryn Lerman on a proposal to broaden the range of the CARE program by procuring a bilingual genetic counselor and the capacity to provide CARE services off site in community settings. All of the clinics belonging to the PAC advisory board submitted letters of support for that proposal and it was funded. While identifying a bilingual genetic counselor was difficult, clinic board members had felt it was necessary that women whose native language is Spanish should be counseled in the Spanish language. The Cancer Genetics Network support made this possible, however resources for Spanish-speaking patient accrual only recently were put in place. A recent cooperative agreement grant application submission to the National Cancer Institute, with the Washington Hospital Center and five primary care clinics serving D.C.-area Hispanics, may provide five years of financial support to continue and extend the DOD Breast Cancer Research Center efforts to involve this hard-to-reach population in breast cancer research.

B. HMO Advisory Board: PAC staff members have redirected their approach in Year III to reaching managed care organizations with a large medically underserved (Medicaid) population. During Year II PAC staff had met with Linda Meili, RN, MS, ONC, Coordinator for Managed Care Programs, Lombardi Cancer Center and Patricia Robinson, Senior Account Manager, Managed Care Department - GUMC. It is believed that a cooperative strategy for reaching managed care organizations may prove more successful. Also, given the legislative attention relating to broadening opportunities for managed care membership participation in clinical research trials, it is believed that

the provision of an informational session (seminar, presentation, symposium) for leaders of area managed care organizations may be of interest. PAC staff will continue to work with LCC and GUMC staff to develop and implement effective ways of reaching out to the dynamic managed care system.

With respect to year III activities, Dr. Kerner met with Cecile A. Comrie, Associate Director for Health Education and Wellness for the D.C. Chartered Health Plan. With 25,000 D.C. Medicaid participants, Chartered represents the largest Medicaid Managed Care Organization in the D.C. region. The enrollee population is almost exclusively African and Latin American. MMG made the initial contact with Chartered, and set up a system to have the five Chartered outreach workers collect family history of breast or ovarian cancer during their regular family visits. Started in March 1999, this system produced approximately 90 family history forms turned in over a six-month period. This volume was well below the daily number of family visits conducted by Chartered (n=60). Moreover, fewer than five of the families for whom history forms were collected were found to be eligible for inclusion in the DOD-supported CARE study.

Chartered has requested more health education information about genetic testing and counseling for its members, and has also requested some form of incentive payment for its outreach workers when they find eligible patients. In response to these requests, the LCC Division of Cancer Prevention and Control health education staff will be meeting with Chartered Health Education staff to plan new health education programs for Charter members on genetic testing and counseling for breast cancer. In addition, we have included a \$50 incentive payment in the 04-year budget to Chartered for each patient enrolled on a designated Breast Cancer Research Center study, up to 150 enrollees.

C. Breast Cancer Education Plan: It was originally intended that the Breast Cancer Resource Committee (BCRC) would develop and promote a campaign around the topic of clinical trials participation for African American women. Half way through the 02 year, BCRC decided that it would not be in their best interest to enter into a contractual agreement with LCC. As such, PAC released a Request for Proposals to identify another provider for this service. Proposals were narrowed to three strong candidates. After review of the proposals by PAC staff and Breast Cancer Center investigators the decision was made to award the subcontract to Matthews Media Group, Inc. (MMG) located in Rockville, Maryland.

MMG has a track record in recruiting patients to clinical research trials. They have worked with the National Cancer Institute in developing materials and systems to aid the recruitment process. In addition, MMG has established a network throughout the metropolitan area consisting of clinics and providers that are supportive of clinical research trials and willing to work collaboratively to set up referral processes for desired study populations.

The sites where they have gained trust, and through which they have been able to accrue, include:

- Area C Chest Clinic
- Arlington County Chest Clinic
- Community for Creative Non-Violence Clinic
- D.C. General Hospital
- *La Clinica del Pueblo*
- *Spanish Catholic Center*
- Upper Cardozo Community Clinic
- *Woodridge Neighborhood Clinic*
- *Zacchaeus & Bread for the World*

The italicized clinics are those already represented on the PAC Clinic Advisory Board. Given that MMG had the capacity for on-site study promotion and accrual, we believed that a potentially better use of DOD funds for patient accrual would be to broaden MMG's contractual role in patient recruitment for the Breast Cancer Research Center trials. DOD approved expanding the MMG contract further by re-budgeting the Year 3 and 4 year funds for the salary plus fringe benefits of the 50% health educator/PAC Coordinator and using these funds to expand the patient accrual contract with Matthews Media Group.

Monthly meetings were set up between MMG, PAC and CARE study staff. During these meetings, MMG reviewed their social marketing approaches to outreach and education of D.C. Region African American populations. MMG focused their recruitment efforts on the CARE protocol, and a target of 100 eligible patients within the 03-year was set. As noted above, MMG was unable to achieve this goal. Based on the barriers identified by MMG and the CARE study's more successful experience with focusing its recruitment in oncology practice settings, LCC and MMG mutually agreed to end the MMG subcontract at the end of the 03 year. At LCC's request, MMG provided the PAC with a Final Project report that outlined the barriers faced and the lessons learned from the one-year MMG experience. A copy of this report can be found in the Appendix Section.

D. Cultural Awareness Training: Education For Quality Living (EQL), an agency based here in Washington DC, conducted a focus group and a series of in-depth interviews in Year 2 to obtain data which would enable them to tailor an existing workshop to the specific needs of LCC staff members. That data was compiled and reported on (poster presentation) at the Cancer and Literacy conference offered by the Moffitt Cancer Center in Florida on April 30th, 1998. The results were appended to last year's progress report.

The *Culture & Health* workshop was offered as a pilot to 12 staff members in June 1998. PAC staff worked with EQL to revise the workshop based upon feedback of this workshop in preparation for a September 1998 workshop. The major changes included a focus on research staff members and greater input from participants with respect to their personal experiences with cancer rather than depend on EQL for that input. No additional workshops were proposed or held in Year III.

E. Patient Transportation Support: Originally, the plan was to utilize the Lombardi Cancer Center van to pick up a group of patients at their referring hospital or clinic site. The logistics of such an endeavor were complicated in that the CARE and CAB/CAD studies require two to four hours of time for each individual to complete their sessions, and only one woman may attend a counseling session or receive diagnostic testing at one time.

To address transportation barriers, alternate mechanisms were put in place for provision of parking and taxi vouchers. It was expected that many of the women referred from the primary care clinics to the CARE and CAB/CAD studies would need to take taxis to get to Georgetown. A system is already in place, for the CAB/CAD study, where women who need to take a taxi are identified during the intake session over the telephone and asked to call a taxi service under contract with Georgetown University Medical Center. When the patient arrives at Lombardi Cancer Center, the project coordinator for the study meets her taxi and provides the driver with a voucher. Likewise, when the patient leaves to go home, a taxi is called and a voucher is provided.

F. Additional Patient Accrual Efforts

Lombardi Extramural Research Consortium (LERC): During the first year of the PAC, additional recruitment efforts were developed at the recommendation of the senior investigators and the Cancer Center's administration. The most intense effort has been the coordination between the PAC and the LCC Extramural Research Consortium. LERC is designed to provide community-based oncology practices the opportunity to deliver research protocol care from a community office setting. As such patients wishing to be considered for a research study can have the protocol care delivered in the comfort of their own oncologist office practice, without having to travel into a Georgetown. The LERC committee meets on a monthly basis, to evaluate new protocols where the LCC PI has requested LERC accrual, and to review accrual, data collection and data management performance of the individual office practices.

This committee has consisted of two representatives from PAC, Dr. Jon Kerner (Associate Director for Prevention and Control) and Lenora Johnson (Senior Health Educator), Dr. John Marshall (Associate Director for Extramural Research, Clinical Research Management Office and Associate Professor of Medicine), and Jan Hewitt (Sponsored Clinical Research Coordinator). This group meets monthly with the LERC staff (1 FTE nurse, 1 FTE data manager) to coordinate those efforts underway to increase research referrals from external sources; namely oncology physicians' practices. To date, the activities of this group has:

- secured funding from the Lombardi Cancer Center to provide additional support for extramural research activities from the Director's shared resources allocations
- conducted focus groups among local community and private practice oncologists and surgeons to identify barriers to partnering for the purpose of clinical trial recruitment
- developed protocol-specific patient information sheets for all community-based cancer patients that have been considered for accrual to LCC clinical trials open to LERC physicians.

The LERC has successfully established a network of four D.C. and three Virginia community office practices which accrued 36 cancer patients (19 breast cancer patients) from July 1, 1998 through June 30, 1999. One of these practices has a relatively large number of Hispanic patients, but none to date have had a significant number of African American patients. Based on the relatively good patient accrual experienced by LERC, in relation to the community outreach and social marketing approaches, Dr. Kerner and Dr. Marshall have agreed to merge the resources of the LERC and the PAC into the Lombardi Education And Research Network (LEARN). The mission of LEARN will be:

- to expand the network of community-based oncology practices that accrue patients to LCC clinical trials, with a targeted effort to add community practices that have a significant number of African American and/or Latin American patients.
- to educate community physicians and their patients about the benefits of participating in new LCC protocols as they are reviewed and approved by the LCC Clinical Research Committee, the GUMC Institutional Review Board, and the LEARN steering committee.

- to educate LCC physician investigators and research staff about how best to recognize and reinforce community physician and patient involvement in LCC clinical trials.

To this end, we propose to take the final year of PAC funding through the DOD Breast Cancer Research Center and link it with LCC funding for LERC to hire a full time LEARN Coordinator. This individual will work with Drs. Kerner and Marshall to: 1) support existing oncology office practices in expanding their breast cancer patient accrual to LCC clinical trails; 2) identify and recruit new community office or hospital-based oncology practices to join LEARN; 3) work with LEARN practices to network out to their referring surgeons and internists to identify those interested in participating in LCC breast cancer prevention and early detection trials; and 4) work with targeted managed care organizations to get their affiliated physicians to participate in LEARN. Long-term support for this position and for LEARN will be based on the success of the LEARN expansion, the number of new and minority patients going on protocol, and the resources collected from sponsored research to which LEARN makes a significant patient accrual contribution.

Community Hospital Partnerships: PAC staff has been communicating with the Providence Hospital (NE Washington, DC) for more than 18 months for the purpose of working through a process for collaboration in clinical research studies. These communications have had a limited impact, in that the hospital CEO has not been involved, and that no one had been designated as Research Director for Providence Hospital. In July 1999, the CEO of Providence Hospital named David P. Milzman, MD as Director of Research for Providence Hospital. In August 1999, Dr. Kerner met with Dr. Milzman to discuss how best to proceed to involve Providence Hospital patients in the DOD Breast Cancer Research Center. Dr. Kerner and Dr. Marshall also plan to meet with Providence to discuss their oncologists joining LEARN.

Finally the PAC obtained a listing from the Maryland Tumor Registry of the ten Maryland hospitals that served the largest number of African American breast cancer patients in the state. Of the hospitals treating the 110 breast cancer cases in Montgomery and Prince George's counties in 1995, Prince George's Medical Center and Doctor's Hospital in Prince George's County treated the most patients. In Year IV, these hospitals will be approached by the LEARN Project Coordinator.

Physician Practices: PAC has developed a database of all oncologists and oncology surgeons in the Washington Metropolitan Area. The list is approximately 250 members in size, which includes multiple offices of a single practice. A letter was mailed to these practices that addresses referrals to clinical trials. A brochure that briefly explains clinical trials accompanied the letter along with the materials already developed and produced for each of the three Breast Cancer Research Center protocols. Twelve physicians responded with an interest in collaborating with GUMC for the purpose of collaborating in cancer treatment trials. Some of these practices have subsequently joined LEARN.

III. KEY RESEARCH ACCOMPLISHMENTS: Not Applicable

IV. REPORTABLE OUTCOMES: Despite considerable effort by the PAC staff to implement the minority patient recruitment plan, through extensive meetings and collaboration with the Community Advisory and Clinic Advisory Boards, and subcontracting to MMG the level of minority patient accrual, to date, has been less than anticipated.

The tables below represent accrual figures for Years 1-3 for the prevention and diagnostic studies.

Accrual Data for CARE Study

Racial/Ethnic Group	Year One		Year Two		Year Three	
	Baseline Only	Baseline & Education	Baseline Only	Baseline & Education	Baseline Only	Baseline & Education
African American	12	7	7	3	10	10
Caribbean or West Indian	0	0	1	0	2	1
White/non-Hispanic	218	161	162	114	337	327
Hispanic	1	1	2	2	6	4
Asian or Pacific Islander	1	1	1	1	2	1
Native American	0	0	1	1	1	1
Other	1	1	4	2	3	2
Unknown	1	0	0	0	0	0
Total	234	171	178	123	361	347
Total Minority Accrual	15 (6.4%)	9 (5.3%)	16 (9.0%)	9 (6.9%)	24 (6.6%)	20 (5.8%)

Accrual Data for CABCAD Study

Racial/Ethnic Group	Year One	Year Two	Year Three
White/non-Hispanic	46	80	37
African American	4	6	4
Hispanic	0	1	0
Asian or Pacific Islander	2	2	0
Other	1	1	0
Unknown	0	0	19*
Total	53	90	60
Total Minority Accrual	7 (13.3%)	10 (11.1%)	4 (6.7%-10.8%)*

*Depending on adjustment for missing race data.

V. CONCLUSIONS: Based on an analysis of this experience, and a review of other successful and unsuccessful efforts at minority clinical trials accrual, the LCC is proposing to expand minority accrual to breast cancer research trials by expanding an existing network of oncology office practices, and their affiliated internist, ob/gyn and surgical practices. We will focus on recruiting office practices that have a large minority patient population. In this manner, on-going relationships can be built where patients can be treated on protocol locally, and the trust and understanding engendered among community physicians and patients by the LEARN program can improve referral to Georgetown protocols where such referrals are necessary.

Given this clinical partnership strategy for minority patient recruitment, through established community-based office practices, the LCC PAC requests the authority to re-budget it's DOD

approved Year 4 funding for the 50% health educator and materials development (including carry over funds from Year 3) to support .62 FTE of the LEARN coordinator.

VI. REFERENCES: Not Applicable

VII. APPENDIX (included in full packet following annual report)

Appendix 1: Matthews Media Group Final Report

CORE 2: CANCER CLINICAL AND ECONOMIC OUTCOMES CORE

I. INTRODUCTION: This Cancer Clinical and Economic Outcomes Evaluation Core has constituted a multi-disciplinary research team (including oncology, nursing, primary care, economics, health services research, psychology, and biostatistics) with broad methodological expertise to conduct evaluations of the costs and outcomes of the new translational technologies evaluated in the three projects included in this Breast Cancer Center grant. Following a review of the general scope of work originally outlined for the Cancer Clinical and Economic Outcomes Evaluation Core (hereinafter referred to as the "Outcomes Core"), we present the progress made in completing our Year 3 objectives for each project, and outline our plans for the last year.

Scope of the Outcomes Core Research: The overarching mission of this Outcomes Core has been twofold: 1) to expand the technical capacity for outcomes evaluations for current and future research at the Lombardi Cancer Center; and 2) to provide expertise and support to the research projects included in the Breast Cancer Center. The Core technical aims are listed below:

1. To conduct cost-effectiveness analyses (CEAs) of each of the projects.
2. To evaluate the impact of tests or treatments on quality of life (QOL).
3. To evaluate the impact of the other Center Core, the Patient Accession Core (PAC).
4. To develop a centralized library of data for use in cancer outcomes research, and provide consultation to investigators on outcomes assessment for new initiatives.

II. BODY OF REPORT: Although the Outcomes Core evaluations are being done in a coordinated manner across all projects, for sake of clarity of presentation, the progress applicable to each project are presented separately. Table 1 presents an overview of our approach for each project. The narrative that follows highlights preliminary results from Year 3 and notes any additions/changes in approach. Finally, this section concludes with a summary of progress on cross-cutting activities (i.e., aims 3 and 4).

Table 1: Overview of Planned Project Specific Outcome Evaluations

	Project #1: Prevention: Genetic Testing	Project #2: Diagnosis: New Technologies	Project #3: Treatment: Novel Palliative Rx
Design	Observational Cohort	Case Series	Phase I, II studies and a Phase III RCT
Outcomes	QOL, Utility, QALYs	Cancers Detected, Delayed, and Missed	QOL, Utility
Costs	Direct and Time Costs	Direct and Time Costs	Direct, Time and Care-giver Costs
Economic Analysis	CEA Model	Cost per Case Diagnosed; Decision Analysis Model	CEA

A. Project #1: BRCA1/2 Genetic Testing: Develop an Exploratory Cost-Effectiveness Analysis (CEA), Combining Primary and Secondary Data, to Identify the Key Parameters Which Drive the Costs and Effectiveness of Genetic Testing and Counseling as a Strategy to Prevent Breast Cancer and Decrease Cancer Mortality among High-Risk Women: The specific objectives of Year 3 were to: 1) continue to collect primary data on patient-related costs of genetic testing, adherence to surveillance guidelines, and preferences for potential outcomes of genetic testing; 2) complete the review of secondary literature to define parameters in the natural history model; and 3) complete programming of the three-dimensional Markov simulation model (to model the simultaneous risk of breast and ovarian cancers, and death from other causes) that will be used to evaluate the cost-effectiveness of genetic testing and counseling. This section summarizes our Year 3 progress in completing these interim objectives.

1. Primary Data Collection: We have now collected data on utilities and time costs from 332 women. Table 2 shows preliminary results for utilities for the hypothetical states of health assessed. Results are presented as 0 (death) to 1 (excellent health) for the TTO, and 0 (death) to 100 (excellent health) for the LRS. To decrease respondent burden, participants randomly receive 2 TTO and LRS assessments for treatment of localized breast cancer (the first 3 scenarios in Table 2), and 1 from the remaining scenarios. Briefly, these preliminary results continue to show that participants tend to have higher utilities measured with the TTO compared to the LRS; this is consistent with other investigators' work (O'Leary, et al, 1995). The utilities for early breast cancer were quite high, especially with the TTO assessment, and the measures were not responsive to changes across the three modes of treatment. The LRS showed a decrease in the utility for in-breast recurrence although the TTO did not (decrease expected). Both assessments showed a large decrease in utilities for metastatic breast cancer and for advanced ovarian cancer.

Table 2. Preliminary Utility Data [Mean (s.d.)]

Scenario	N	LRS
Modified Radical Mastectomy*	221	82.4 (15.5)
BCS/Radiation Therapy*	227	83.5 (14.8)
Prophylactic Bilateral Mastectomy*	225	81.2 (14.9)
Prophylactic Bilateral Oophorectomy*	67	79.4 (17.5)
Breast Cancer Recurrence	77	75.1 (17.5)
Metastatic Breast Cancer	64	50.7 (17.1)
Ovarian Cancer	61	45.7 (23.5)
Current Health	55	82.2 (13.3)

* With early stage breast cancer.

Due to utility results that were higher than expected, we continued our efforts begun at the end of year 2 to validate the phone assessments with face-to-face utility interviews. For this evaluation, we sampled a subset of the 332 women who came to Georgetown for genetic counseling. To date, 22 women have undergone both a phone and face-to-face utility interview. In the face-to-face interview,

women receive the same three scenarios in the same order as assessed via the baseline phone interview. Correlation between the phone and face-to-face LRS assessments was 0.75, which we consider to be reasonable. The correlation between phone and face-to-face TTO assessments (Spearman rank correlation, used for skewed data) was 0.35. In open ended questioning, participants were able to relate an understanding of the hypothetical health states. Based upon this low correlation, we have dropped the telephone-administered TTO assessments from the interview.

We also continued to assess participants' current health using a utility index, or a survey that provides a societal utility for a participant's state of health. We have used a modification of the Health Utilities Index (HUI) (Feeny, et al., 1996), abbreviated by removing low-variation response items as determined by the breast cancer Patient Outcome Research Team results. The average HUI score for 276 participants was 0.83 (s.d. 0.0097), on a scale ranging from 0 (death) to 1 (excellent health). The HUI showed a significant decrease with age, with participants under age 40 averaging 0.87 and participants age 60 and older averaging 0.78. The HUI score for the participant's current health correlated moderately well with the LRS ($r=0.48$, $p=0.0003$) for the participants' current health.

The next portion of our work has included assessing the costs of counseling and testing. An important component of the overall cost of a BRCA1/2 testing program is the cost incurred in genetic counseling. We have completed this task, and have a manuscript summarizing our results under review (Appendix 1). Briefly, the results demonstrated that providing genetic counseling only to women at high risk of carrying a mutation cost on average \$207, while providing testing (full gene sequencing of BRCA1/2), counseling, and disclosure of results totaled \$2051. While the cost of counseling and testing together exceeded \$2000, the cost of providing the counseling (including disclosure of results) comprised only 16% of the total cost. We conclude from this analysis that: 1) while counseling is an important part of a genetic evaluation, it has a low cost relative to testing; and 2) since the cost of counseling is a small part of the overall cost of counseling and testing, replacement of detailed genetic counselor counseling with a shorter time of physician counseling would not significantly lower costs.

Finally, in Year 3 we requested and obtained age- and stage-specific treatment costs for breast cancer from the SEER-Medicare linked data; we are in the process of obtaining these data for ovarian cancer.

2. Analysis of Data to Develop Model Parameters: In Year 3 we completed the review of the literature to estimate the effects of all possible events that flow from the initial testing choices, the probability of each event, and the probability of transition from one state to the next. Using standardized data abstraction tools developed in Year 2, data were abstracted from the best designed and least biased studies available (e.g., well designed randomized clinical trials and observational studies, and administrative databases, such as SEER). We have also used meta-analytic techniques to derive effect size estimates (e.g., the expected cancer risk reduction associated with bilateral mastectomies). The final parameter values are included in Table 3. In Year 4 of the grant we will convert these data to probability distributions for use in the cost-effectiveness model Monte Carlo simulation. As can be seen from the table, the prevalence of BRCA1 is very dependent on the population examined, ranging from under 1% in the general population to almost 70% in some hereditary breast-ovarian cancer families. BRCA1/2 prevalence for the baseline cost-effectiveness analysis will be based upon data from Project #1; prevalence data in the table will be used for determining parameter distributions and for sensitivity analysis.

Table 3. Final Model Parameter Estimates

Parameter	Estimate (Range)	Sources
Initial Tree		
Prevalence of BRCA genes		
General population BRCA1	0.0045 (0.00 ~ 0.026)	Claus, 1991; Ford, 1995; Oddoux, 1996; Roa, 1996; Whittemore, 1997; Malone, 1998; Newman, 1998
High-risk population BRCA1	0.155 (0.0029 ~ 0.6875)	Offit, 1996; Hakansson, 1997; Shattuck-Eidens, 1997; Couch, 1996; Malone, 1998; Schubert, 1997; Whittemore, 1997; Ford, 1995; Struewing, 1997; Rebbeck, 1996; Langston, 1996; Zelada-Hedman, 1997; Newman, 1998; Roa, 1996
BRCA2	0.067 (0.00 ~ 0.273)	Neuhausen, 1996; Hakansson, 1997; Schubert, 1997; Lancaster, 1996; Struewing, 1997; Rebbeck, 1996; Oddeux, 1996; Roa, 1996
Sensitivity of full gene sequencing	98% (85 ~ 100%)	Myriad Genetic Laboratories, 1998
Specificity of full gene sequencing	99% (98 ~ 100%)	Myriad Genetic Laboratories, 1998
Probability of prophylactic bilateral mastectomy given BRCA+ results	0.023	Project I data
BRCA1 (+) vs BRCA2 (+)		Data to be provided by Project I
Probability of prophylactic bilateral oophorectomy given BRCA+ results	0.164	Project I data
BRCA1 (+) vs BRCA2 (+)		Data to be provided by Project I
Probability of prophylactic bilateral mastectomy and oophorectomy	0.063	Project I data
BRCA1 (+) vs BRCA2 (+)		Data to be provided by Project I
Probability of receiving Tamoxifen chemoprophylaxis, BRCA1/2 (+)	0.10	Data to be provided by Project I
Probability of intense breast cancer screening, BRCA1/2 (+)	0.650	Data to be provided by Project I
BRCA1/2 (-)		Data to be provided by Project I
Probability of usual breast cancer screening with no genetic tests in high risk population		Data to be provided by Project I
Probability of intense breast cancer screening with no genetic tests in high risk population		Data to be provided by Project I
Disease Initiation Model		
Population all-cause mortality	(0.001 ~ 0.059) [§]	Statistics Abstract of the United States, 1995
Breast cancer incidence		
Cumulative probability of BRCA1 (+)		
By 50 years old	0.50 (0.33 ~ 0.73)	Easton, 1995; Ford, 1994; Narod, 1995; Struewing, 1997; Whittemore, 1997

By 70 years old	0.74 (0.56 ~ 0.87)	
Cumulative probability of BRCA2 (+)		
By 50 years old	0.30 (0.28 ~ 0.32)	Schubert, 1997; Ford, 1998
By 70 years old	0.76 (0.67 ~ 0.84)	
BRCA1/2 (-)	(0.00001 ~ 0.00304)*	SEER, 1991-1995
After prophylactic bilateral mastectomy	0.0054	Hartmann, 1997
Ovarian cancer incidence		
Cumulative probability of BRCA1 (+)		
By 50 years old	0.18 (0.07 ~ 0.29)	Easton, 1995; Ford, 1994; Narod, 1995; Struewing, 1997; Whittemore, 1997
By 70 years old	0.40 (0.16 ~ 0.63)	
Cumulative probability of BRCA2 (+)		
By 50 years old	0.004	Ford, 1998
By 70 years old	0.27	
BRCA1/2 (-)	(0.00003 ~ 0.00063)*	SEER, 1991-1995
Surveillance[†]		
Breast cancer		
Mammography / CBE		
Sensitivity	82.8 % (74 ~ 88%)	Shapiro, 1988; Chamberlain, 1991; Miller, 1992; Fletcher, 1993
Specificity	98.7% (97.7 ~ 99.8%)	
Ovarian cancer		
Conventional transvaginal ultrasound		
Sensitivity	81.6% (0 ~ 100%)	Grover, 1995; DePriest, 1997; Bourne, 1993; van Nagell Jr., 1991; Franchi, 1995; Hata, 1992; Zantta, 1994; Weiner, 1992; DePriest, 1994;
Specificity	81.4 % (65.4 ~ 98.7%)	
Doppler transvaginal ultrasound		
Sensitivity	89.9% (75.7 ~ 100%)	Franchi, 1995; Hata, 1992; Kawai, 1992; Zanetta, 1994; Weiner, 1992; Caruso, 1996; Vuento, 1995; Kurjak, 1992; Tepper, 1995; Bourne, 1993
Specificity	86.9 % (52.8 ~ 99.2%)	

CA-125		
Sensitivity	79.7% (44.4 ~ 100%)	Franchi, 1995; Maggino, 1994; Jacobs, 1994; Helixsouer, 1993; Soper, 1990; Hata, 1992; Kawai, 1992; Zanetta, 1994; Peters, 1995; Gadducci, 1996; Weiner, 1992; Jacobs, 1992; Zurawski, 1990; Grover, 1995
Specificity	77.7 % (40.0 ~ 100.0%)	
Breast cancer treatment (Probability of getting certain types of treatment)		
Local/regional breast cancer		
Mastectomy	64.3% (37.4 ~ 85%)	Satariano, 1994; Young, 1996; Nattinger, 1996
Breast conserving surgery with radiation therapy	31.8% (15 ~ 51.1%)	Young, 1996; Satariano, 1994; Nattinger, 1996
Tamoxifen	13.4% (2 ~ 29%)	Kurtz, 1989; Quiet, 1995; Smith, 1994; Zissiadis, 1997; Kini, 1998; Haffty, 1991; Matthews, 1988; Hacene, 1990; Fourquet, 1989
Chemotherapy	14.1% (5 ~ 34%)	Recht, 1996; Kurtz, 1989; Quiet, 1995; Smith, 1994; Zissiadis, 1997; Kini, 1998; Haffty, 1991; Hacene, 1990; Fourquet, 1989
Breast cancer natural history		
Incidence of breast cancer by age and stage		SEER, 1990-1995
Probability of DCIS to invasive breast cancer	5% (yearly rate)	Page, 1982
Breast cancer treatment (Yearly breast cancer stage transition probabilities after treatment)		
DCIS to Local	1.2% (0.5 ~ 1.9%)	Fisher, 1993; Fowble, 1997
Local to Local	1.2% (0.37 ~ 2.8%)	Recht, 1996; Eberlein, 1990; Vicini, 1992; Kurtz, 1989; Zyl, 1995; Fisher, 1989; Smith, 1994; Pierce, 1992; Zissiadis, 1997; Kini, 1998; Horiguchi, 1997; Powles, 1995; Hacene, 1990
Local to Regional	1.6% (0.04 ~ 6.4%)	Recht, 1996; Zyl, 1995; Fisher, 1989; Smith, 1994; Pierce, 1992; Zissiadis, 1997; Horiguchi, 1997; Powles, 1995
Regional to Regional	3.5% (1.1 ~ 6.0%)	Cooke, 1995
Regional to Distant	6.0% (4.1 ~ 8.2%)	Cooke, 1995; Fisher, 1997; Hacene, 1990
Probability of local/regional recurrence after treatment of local or regional breast cancer	12.7% (3.3 ~ 35.9%)	Rutgvist, 1993; Kurtz, 1989; Jacobson, 1995; Quiet, 1995; Ferguson, 1982; Demicheli, 1996; Huseby, 1988; Fletcher, 1989; Ragaz, 1997; Arriagada, 1996; Kini, 1998; Haffty, 1991; Matthews, 1988; Fourquet, 1989; van Dongen, 1992; Lee, 1984; Orel, 1993

Probability of local recurrence given recurrence	28.4% (0 ~ 87.5%)	Fisher, 1993; Zyl, 1995; Fisher, 1996; Fisher, 1989; Smith, 1994; Pierce, 1992; Zissiadis, 1997; Horiguchi, 1997; Powles, 1995; Fowble, 1997
Probability of regional recurrence given recurrence	14.8% (0 ~ 50%)	
Probability of distant recurrence given recurrence	56.8% (6.3 ~ 90.8%)	
Median survival, distant stage of breast cancer (months)	20.2 (9.5 ~ 28)	Patanaphan, 1988; Koenders, 1992; Kimmick, 1991; Brincker, 1988; SEER, 1989-1994 [‡]
Ovarian cancer natural history		
Incidence of ovarian cancer by age and stage		SEER, 1990-1995
Ovarian cancer treatment (Yearly ovarian cancer stage transition probabilities after treatment)		
Local to Local	3.3% (2.6 ~ 4%)	Piver, 1988; Lentz, 1991
Local to Regional	8%	Wils, 1989
Regional to Regional NED	14.8% (5.7 ~ 22%)	Zylberberg, 1990; Hahn, 1985; Rubin, 1988; Tarraza, 1993
Regional to Regional	6.8% (6.5 ~ 6.9%)	Zylberberg, 1990; Hahn, 1985; Sigurdsson, 1983;
Regional to Distant	4.4%	Sigurdsson, 1983
Median survival, distant stage of ovarian cancer (months)	23.3 years	Munkarah, 1997; Piver, 1994; Omura, 1991; Goodman, 1992; Lund, 1990; Sutton, 1989; Akinkugbe, 1985; Chiara, 1994

§ Expected deaths over alive at specified age between 20 and 80 years old.

* Incidences of invasive breast or ovarian cancer in every 5 years from 20 to 85+ years old.

† Data summarize the accuracy of screening for breast cancer and screening or diagnosis for ovarian cancer.

‡ Derived from the 5-year survival rate of distant breast cancer.

3. Stochastic Simulation Model of Simultaneous Breast, Ovarian, and Other Cause Mortality: The model evaluates three strategies: genetic testing for BRCA1 mutations and counseling, counseling alone, and routine medical practice/surveillance. In terms of mapping primary data to the model, these three groups correspond respectively to the following groups in Project #1: women agreeing to testing and counseling, women counseled who decline testing, and women who decline testing and counseling. Figure 1 summarizes our basic modeling approach. The first decision point is whether or not a woman decides to having BRCA1/2 testing and/or counseling. If she accepts, she has a certain pre-test probability of testing positive for the mutation. Each pathway is also associated with certain probabilities of morbidity and mortality. For instance, there may be decrements in quality of life associated with knowledge of mutation positivity, or anxiety associated with evaluation of positive (and false-positive) early detection tests, or morbidity or mortality associated with undergoing prophylactic surgery. Ultimately, these paths would lead to death from breast or ovarian cancer or non-cancer related causes.

There are several unique aspects of this analysis that have guided our approach, including the facts that 1) the impact of genetic testing on survival (and costs) occurs distal to the intervention in Project #1, and 2) much of the data on the effectiveness of prevention and early detection strategies for mutation positive women are still uncertain. Thus, we have completed programming of a mathematical stochastic simulation model to extend the analysis time horizon; the best quality recent literature being reviewed; and sensitivity analyses will address the impact of uncertain parameters on cost-effectiveness results. Based on recent data, the model has also been updated to include a choice of tamoxifen use for prevention of cancer.

In Year 3, we developed the program for the decision model. We are using C++ programming language. We have included procedures to allow limited memories in the models (semi-Markov models), so that we may revise transition probabilities for cancer progression based upon past events (e.g. to allow higher progression rates if a patient has had a breast cancer recurrence). We have conducted preliminary data runs with the program and performed debugging. We have also begun to incorporate the effectiveness, utility, and cost data into the mathematical

Flow Diagram of BRCA 1/2 Natural History Model

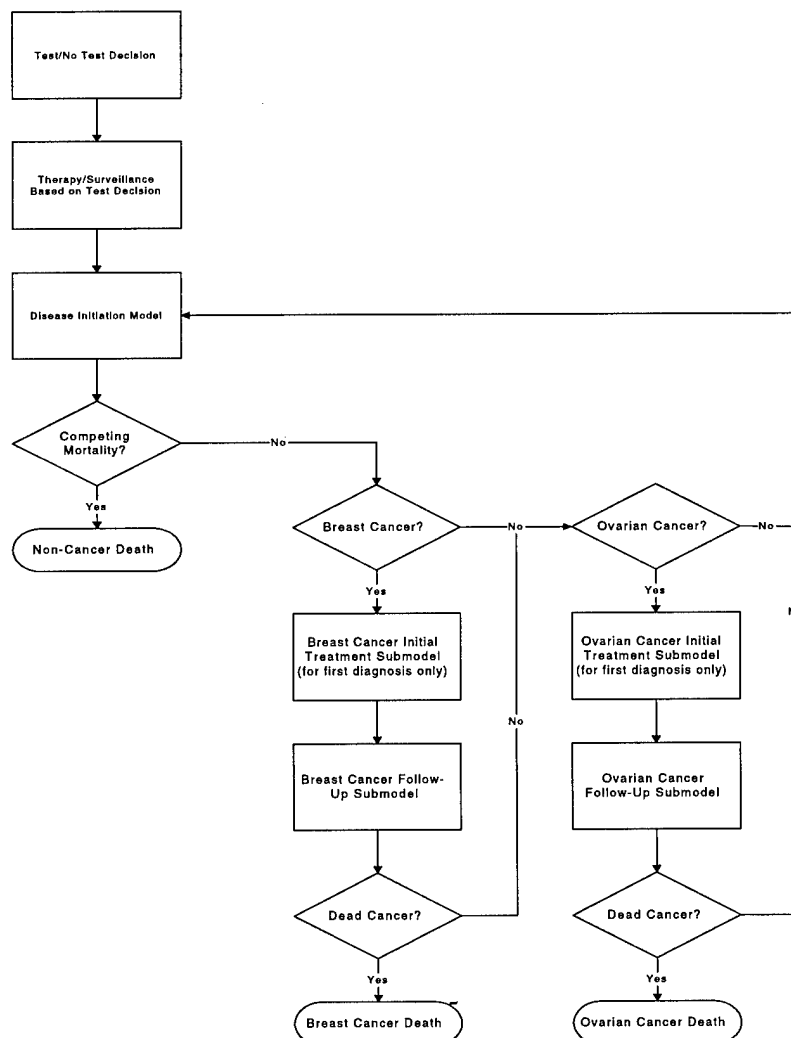

simulation model of the cost-effectiveness of genetic testing and counseling. In the final project year, we will complete analyses of all primary data (utilities, time and counseling costs, and surveillance practices), finalize all model parameters, validate the model, and complete the CEA primary and sensitivity analyses. A draft outlining the CEA paper is included in Appendix 1.

B. Project 2: Coordinated Approach to Breast Cancer Diagnosis: Technical Aim: Conduct an economic evaluation, develop a decision analysis model comparing the costs per cancer detected for new breast cancer diagnostic evaluation strategies, and assess test-related patient Satisfaction: Project #2 is prospectively enrolling a cohort of approximately 199 white and African-American women, from several DC-metropolitan area clinics, hospitals, and HMOs, who have abnormal breast physical examination, mammography, and/or standard sonography results and have been recommended to have a breast biopsy. The goals of the project include evaluating the accuracy of several simultaneously administered new technologies. We have collected satisfaction data on digital mammography, magnetic resonance imaging (Gd-DTPA enhanced MRI), nuclear medicine evaluation (Tc-99m-sestamibi scanning), special ultrasound evaluation (radio frequency elastography imaging), and nipple aspirate fluid (NAF) cytology. Please see Project #2 report for current and future status of imaging technology used in this project. Women with negative biopsies will receive 12-month follow-up mammography and CBE.

The Outcomes Core objectives for this project are to: 1) conduct an economic evaluation to compare the costs per cancer detected for each for each of the innovative diagnostic technologies; 2) using the general methods of decision analysis and modeling described above for the genetic testing project, use the primary data on test sensitivity, specificity, and costs, combined with natural history data (e.g., molecular markers in NAF), to develop a decision analysis model for hypothetical cohorts of women comparing the costs per intermediate outcome (correct early diagnosis, delayed diagnosis, and missed diagnosis) for alternative diagnostic tests (or combination of tests) and surgical excisional biopsy; and 3) to evaluate the acceptability of, and satisfaction with, the tests.

1. Satisfaction and Acceptability of Tests: In Year 3, we continued to collect primary data from women on their satisfaction with the tests. A short self-administered questionnaire is given to women by the project coordinator after completion of all tests. We measure two components of satisfaction with the diagnostic tests in Project #2, discomfort and embarrassment. To provide a relative standard, we asked the participants to rate discomfort of the tests compared to having a routine mammogram. To date, we have 95 survey respondents; 18 women have refused. Of these respondents, 48.4% reported a routine mammogram to be "extremely uncomfortable," and 84.2% considered mammograms to be "not embarrassing at all." Among those receiving the test, 93.8% of those receiving ultrasonography, 75% of those receiving MRI, 19.2% of those receiving digital mammography, 88.3% of those receiving sestamibi imaging, and 13.3% of those receiving a nipple aspirate found the procedure more comfortable than a mammogram. The procedure was less embarrassing than mammography for 17.3% of those receiving MRI, and 12.8% of those receiving sestamibi imaging.

We also ask participants to rate their overall satisfaction with participating in the study. We use a modification of the Medical Outcomes Study Visit Rating Questionnaire (Rubin, et al., 1993),

measuring satisfaction with the receiving the tests overall, with the technical skills of the staff, the personal manner of the staff, the convenience of getting the tests, the length of time spent waiting for the tests, and the explanation of what was done for the participants. On a scale from 0 to 100, where 100 represents the highest possible satisfaction score, the mean score was 95.8 (s.d. 7.64).

We have also used willingness to pay assessment as a measure of "process utility," or a measure of preference for the procedures a woman must undergo to achieve a health outcome. Our measures ask the participant how they think a woman would be willing to pay out of pocket to have one of the tests they experienced in Project #2 *instead of* a biopsy procedure. We asked this under two conditions: first, if the test was as accurate at diagnosing cancer as a biopsy; and second, if the test was almost (95%) as accurate as a biopsy. We asked participants to imagine the test was whichever test they would most prefer having, to avoid the respondent burden of asking about each test separately. Thus, the assessment provides the maximum the respondent would be willing to pay for any of the tests. Under conditions of equal accuracy to a biopsy, the 75 women who provided a response were willing to pay an average of \$257 to have a test instead of a biopsy (range \$0-\$2,000), with 25.3% of women not willing to pay any money out of pocket. The willingness to pay significantly decreased to an average of \$187 in the case of 95% accuracy (range \$0-\$2,000), with 33.3% of women not willing to pay any money (t-test $p=0.0002$). Based on this interim data, we conclude that women find the test preferable to biopsy, although a significant minority of participants would either be indifferent or prefer biopsy if the test were less accurate than biopsy for diagnosing cancer.

2. **Decision Analysis:** We have already developed a preliminary decision analysis model to calculate the incremental cost per cancer diagnosed (intermediate outcome) and years of life saved (final outcome) for the use of single and paired combinations of diagnostic tests for follow-up of an abnormal mammogram and/or clinical breast examination, compared to a surgical excisional biopsy. The strategies to be compared include digital mammography, sestamibi scan, breast ultrasound, and breast MRI, singly and in paired combination, compared to surgical excisional biopsy for follow-up of suspicious breast abnormalities (on mammogram [films interpreted as suspicious or positive for cancer] or clinical breast exam). We will examine two time frames: one short-term frame (through the completion of the diagnostic evaluation of the breast abnormality), and one long-term (from point of diagnostic evaluation through death). For the short-term time horizon of analysis, we will not discount results to present value; the long-term analysis will discount future costs and health effects at a rate of 3%.

The model will be also used to estimate the number of true positive and false negative diagnoses, based upon the prevalence of disease in the population. Figure 2, below, includes the preliminary decision tree for this model. In the final year, data for parameters in the model will be derived from Project #2, the published

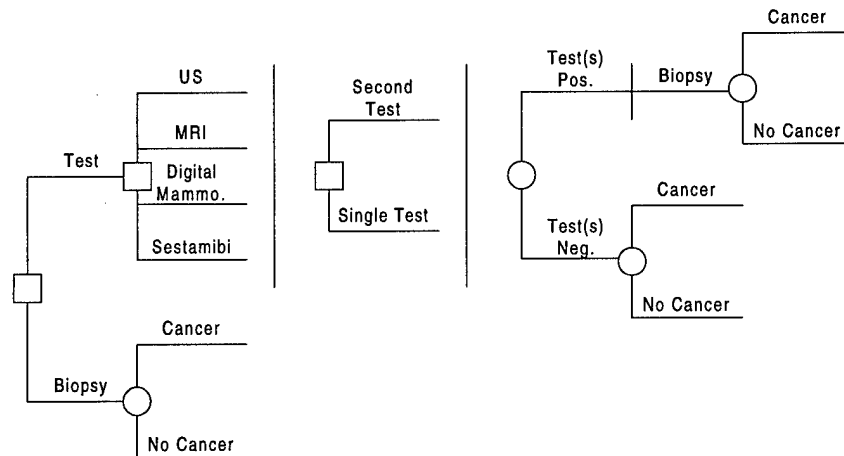

literature, other Outcomes Core related projects, and Dr. Hillner's (Advisor) prior research. An important goal of Project #2 (and the decision/CEA analysis) is to identify the optimal diagnostic algorithm for follow-up diagnostic testing for women with suspicious mammographic abnormalities or clinical breast examinations. This goal guided the development the decision model. All testing algorithms are compared to the gold standard diagnostic work-up of surgical excisional biopsy. We consider the four potential diagnostic tests in comparison to biopsy. For each test, the choice could be made to use the test alone, or add a second diagnostic test (of the remaining 3 tests). We have chosen to simplify the analysis by restricting consideration to single diagnostic tests or to paired combinations; in sensitivity analysis, we will examine more than two tests in combination. In the decision tree, women with screen-detected abnormalities may have palpable or non-palpable masses; diagnostic tests (or pairs of tests) may be interpreted as positive, negative, or indeterminate for a cancer; negative women will return to routine screening; women with falsely negative results will have delayed diagnosis; women with indeterminate results can either have other tests performed immediately or under-go interval re-screening (i.e., 3-4 months later); women who are positive may have cancer or not; etc. In this manner we will calculate the number of women correctly diagnosed with cancer, and the impact of test results on life expectancy.

We will also address two important issues in these analyses. First, the results of combinations of tests can be interpreted either in series or in parallel. If tests are performed in series, the first test is performed, and if positive, the second test is performed. If tests are performed in parallel, then both tests are performed, and if either test is positive then the woman is considered to have a positive diagnostic work-up, and a biopsy would be recommended. For our base analyses, we will assume parallel use of paired tests, as this strategy most closely matches the experimental conditions of Project #2 and maximizes the overall sensitivity of the combination of test pairs (i.e., minimizes the number of false negative diagnoses).

The second issue that must be addressed is that of conditional dependence of diagnostic accuracy between the tests. Typically in decision analyses, if two diagnostic tests are to be used, analysts assume conditional independence of test results (i.e. the results of the second test are independent of the findings of the first test). This approach is usually necessary because there are no data on test dependencies. In the case of Project #2, all four diagnostic tests are being performed for all

women, we can examine conditional dependence of test results. For instance, we can calculate the probability that an ultrasound will provide a true positive result given that a sestamibi scan was negative. We can then incorporate these conditional diagnostic accuracies into the model when we are examining paired combinations of tests, allowing for more clinically valid model results.

The costs for this decision model/CEA will include test costs and patient-related costs as measured in Project #2, and all downstream costs (from secondary sources). The general approach to estimating down-stream costs will be similar to that described for the CEA of BRCA1/2 genetic testing, above. Work completing the model and final analyses will be done in Year 4.

3. **Economic Evaluation:** Data for the economic evaluation of the diagnostic tests will be collected in the final year; analyses will be also completed in Year 4. We will use actual costs of the tests, including equipment and staff time; patient costs will be imputed from travel and test time (collected in the satisfaction survey, above).

4. **Other:** During the course of Project #2, a number of lesions were noted serendipitously on MRI that were not visualized on the index abnormal mammogram.. Since clinicians were concerned about the relevance of these lesions and their probability of being cancer, we constructed a decision model to estimate the probability that these serendipitous lesions were benign if the initial lesion was found to be benign. These results demonstrated that, under our baseline assumptions about the diagnostic accuracy of MRI and mammography, the probability of a lesion being malignant was extremely low. For instance, assuming sensitivity and specificity values of 95.6% and 68.6%, respectively, approximately four of 1000 55- to 59-year-old women with serendipitous lesions would be expected to have cancer (positive predictive value=0.44%). We conclude that immediate biopsy of such serendipitous lesions found on breast MRI would may not be required. The paper was featured in the Journal of the National Cancer Institute and accompanied by an editorial (Appendix 2).

C. **Project #3: RCTs of Novel Palliative Treatments for Metastatic Breast Cancer:** Project #3 has enrolled white and African-American men and women for a phase I trial of TNP-470 plus paclitaxel in metastatic cancer, in preparation for a phase III trial in metastatic breast cancer. We are providing descriptions of quality of life of trial participants; since this trial has accrued limited numbers, the QOL data will be considered preliminary to guide the measurement of the phase III trial (should the ongoing trial suggest that the phase III trial should be conducted). In addition, due to the limited accrual and the restriction to a phase I trial, it will not be feasible to reliably describe the quality-adjusted survival and costs per unit of clinical outcomes associated with these therapies. These data will be helpful in preparing for QOL and economic evaluation of larger scale trials based upon the current trial.

We are currently finishing data collection in this phase I trial. Data being collected include the FACT-B, a breast cancer specific health profile survey, the HUI (Feeny, 1996), a health utilities index providing societal preference for health, and the LRS assessment, a holistic assessment of a participant's preference for her state of health. The FACT-B measures health on 6 domains: physical well-being (PWB), social well-being (SWB), relationship with doctor (RWD),

emotional well-being (EWB), functional well-being (FWB), and additional breast cancer specific concerns (BCS). We also measure the Rotterdam Symptom Checklist (de Haes, et al., 1990), which provides a listing of possible symptoms, and a modified version of the Medical Outcomes Study Visit Rating Questionnaire (Rubin, et al, 1993), to assess satisfaction with participation in the trial.

D. Develop a Centralized Library of Data for use in Cancer Research on QOL, Utility, and Cost Measurement Tools and Approaches, and Provide Consultation to Investigators on the Incorporation of Such Tools into New Research Initiatives: The development of this comprehensive cancer outcomes library is occurring over the entire four years of the project, with most activity targeted for Years 3 and 4. We are still considering a private-public partnership to apply for an SBIR grant to make such a library available on the worldwide web and/or CD ROM. To date we have completed review of 29 QOL instruments. The format for data abstraction and samples of completed reviews for selected tools are included in Appendix 3.

1. Consultations: In Year 3 we continued providing consultations to Lombardi investigators on the use of outcomes measures in cancer research. One example of a successful consultation included the funding of a project exploring methods to measure the quality of life for patients and caregivers at the end of life. Appendix 4 contains the abstract and face sheet for this grant, and the summary of other consultation activities.

2. Outcomes Core Meetings: The Core has continued to meet regularly during Year 3 to discuss current activities and potential new directions. Minutes of these meetings are included in Appendix 6. In Year 3, the format of these meetings was expanded to include educational seminars for all Lombardi staff. A summary of the seminar series is included in Appendix 6.

3. Grant Submissions: In Year 3 Outcomes Core members have contributed to, or have been the lead investigators for 3 newly funded peer-reviewed grants that highlight cancer clinical and/or economic outcomes evaluations. Moreover, 14 new grant applications were submitted (Table 4). Note that Dr. Rowland has left Georgetown for a position at NCI; Dr. Taylor will provide QOLn and psychosocial expertise to the Core.

Table 4. New Active and Pending Outcomes Grants

Principal Investigator	Core Members	Title
<i>Active</i>		
Ganz	Rowland Mandelblatt Lawrence	Breast Cancer Preparing for Survivorship National Cancer Institute
Lippman	Burnett Lawrence Mandelblatt Taylor	Cancer Center Support Grant - Administrative Supplement to Study the Impact of Cancer on the Family National Cancer Institute
Schwartz	Lawrence	Interactive Decision-Aid for BRCA1/2 Mutation Carriers National Cancer Institute
<i>Pending</i>		
Adams-Campbell	Burnett Lawrence	A RCT to Enhance Mammography Utilization Among African- American Women National Cancer Institute
Ingham	Burnett Lawrence Mandelblatt Taylor	Cohort Study of Cancer Patient Caregiver Outcomes National Cancer Institute
Lawrence	Lawrence Mandelblatt Gold	BRCA Genetic Testing: A Primary Care Perspective National Cancer Institute
Lawrence	Lawrence Mandelblatt Gold	Breast Cancer Genetic Susceptibility Testing: A Primary Care Perspective Department of the Army
Lawrence	Lawrence Taylor Mandelblatt Gold	Preferences for Prostate Cancer Screening Outcomes Department of the Army
Lawrence	Lawrence Liang	Cost-Effectiveness of Bupropion for Smoking Cessation (Submitted to NCI as part of a P1 proposal - M Lippman, PI)
Lawrence	Lawrence	Cost-Effectiveness of <i>SLC6A3</i> Gene Testing to Direct Smoking Cessation Therapy (Submitted to NCI as part of a TTURC proposal - C Lerman PI)
Liang	Liang Mandelblatt Taylor	The Impact of Physician-Patient Communication on the Use of Screening Mammography among the Elderly Susan G. Komen Breast Cancer Foundation
Liang	Liang Mandelblatt Taylor	The Impact of Physician-Patient Communication on the Use of Screening Mammography among the Elderly Bayer Institute of Health Care Communication
Mandelblatt	Mandelblatt Lawrence	Decisions and Outcomes of Chemotherapy in the Elderly Cancer and Leukemia Group B
Mandelblatt	Mandelblatt Lawrence	Chemotherapy Outcomes for the Elderly Off and On Trial Cancer and Leukemia Group B
Mandelblatt	Mandelblatt	Ageing, Gene, Environment Interactions in the Risk of Having Breast Cancer Department of the Army
Marshall	Lawrence	Burden of Colorectal Cancer Care in a Managed Care Population
Sternas	Burnett	Breast Cancer: Counseling, Companions, and Quality of Life National Institute of Nursing Research

Core-Related Manuscripts

First Author	Core Members	Title	Status
Lawrence	Lawrence Liang Mandelblatt	Serendipity in Diagnostic Imaging: Magnetic Resonance Imaging of the Breast	Published <i>J Nat Cancer Inst</i>
Lawrence	Lawrence	Does Over the Counter Nicotine Replacement Therapy Improve Smokers' Life Expectancy	Published <i>Tobacco Control</i>
Lawrence	Lawrence Liang Mandelblatt	Cost of Genetic Counseling and Testing for BRCA1 and BRCA2 Breast Cancer Susceptibility Mutations	Under Review
Liang	Liang Lawrence Mandelblatt	An Exploratory Model of the Relationships Between Personal and Structural Factors and Patterns of Preventive Health Behaviors	Under Revision for <i>Preventive Med</i>

4. **Publications:** In Year 3, 2 papers were accepted for publication and 2 were submitted for peer review (Abstracts and Title pages are included in Appendix 1).

5. **Assess the Impact of the Patient Accession Core:** Based on the difficulty in attributing new minority accrual to the Patient Accession Core (PAC), we have revised our evaluation plan for this portion of the project. We will evaluate the overall costs of the PAC activities in relation to total LCC minority accrual in the period the PAC was active.

III. KEY RESEARCH ACCOMPLISHMENTS

- 2 Publications
- 14 grant submissions
- completion of Preliminary analyses

IV. REPORTABLE OUTCOMES

- 2 Publications
- 14 grant submissions
- Completion of Preliminary analyses
- 2 Presentations
- Development of junior faculty (Dr. Liang)
- Appointment of Dr. Mandelblatt as Vice Chair of the Clinical Economics Sub-Committee of the CALBG Cancer Control and Health Outcomes Committee
- Appointment of Dr. Lawrence as member of the Clinical Economics Sub-Committee of the CALBG Cancer Control and Health Outcomes Committee

V. CONCLUSIONS: The science of conducting outcomes research, including economic evaluations in oncology practice, is a relatively new discipline and one which is rapidly evolving. This Outcomes Core is extending the state-of-the-art by consisting a unique cross-disciplinary research team with the methodological expertise to evaluate the costs and benefits of new and existing cancer services. Incorporating clinical and economic outcomes into center-wide research focused on translating new advances from the laboratory to individuals, and from a cancer center to community-based hospitals, managed care organizations, and community groups is allowing Lombardi Cancer Center to expand its leadership position to informing on-going clinical, policy and resource allocation debates. As we continue balance efforts to contain costs while providing care that maximizes health and quality of life, cost-effectiveness and other outcomes analyses, such as those outlined in this Core, will be critical to understanding which treatments work best, under which circumstances, for which populations, and at what cost.

VI. REFERENCES

Cella DF, Tulsky DS, Gray G, et al: The functional assessment of cancer therapy (FACT) scale. development and validation of the general measure. *Journal of Clinical Oncology* 11;570-579, 1993.

DeHaes JCJM, van Knippenberg FCE, Neijt JP. Measuring psychological and physical distress in cancer patients: Structure and application of Rotterdam Symptom Checklist. *Brit J of Cancer* 1990; 62: 1034-1038.

Doyle DL. The 1996 Professional Status Survey. *Perspectives in Genetic Counseling*. 1996;18 (3 Suppl):1-8.

Feeny DH, Torrance GW, Furlong WJ. Health Utilities Index. In: Spilker B, ed. *Quality of life and pharmacoeconomics in clinical trials*, 2nd Ed. Lippincott-Raven, Philadelphia, 1996.

Froberg DG, Kane RL (1989). Methodology for measuring health-state preferences. II: Scaling methods. *Journal of Clinical Epidemiology*, 42, 459-71.

O'Leary JF, Fairclough DL, Jankowski MK, et al. (1995). Comparison of time-tradeoff utilities and rating scale values of cancer patients and their relatives: Evidence for a possible plateau relationship. *Medical Decision Making*, 15, 132-37.

Rubin HR, Gandek B, Rogers WH, Kosinski M, McHorney CA, Ware JE. Patients' ratings of outpatient visits in different practice settings. *JAMA*. 1993; 270:835-840.

Torrance GW. Utility approach to measuring health-related quality of life. *J Chronic Dis* 40;593-600,1987

VII. APPENDICES (included in full packet following annual report)

Appendix 1: Publications and Submitted Manuscripts

Appendix 2: Outline of Cost-Effectiveness of BRCA1/2 Counseling and Testing Manuscript

Appendix 3: Quality of Life Library – Sample Data Abstraction Form

Appendix 4: Active and Pending Grants (Year 3)

Appendix 5: Core Consultations

Appendix 6: Core Meeting Minutes and Core Seminar Schedule

APPENDIX PACKET

PROJECT 3

Appendix 1: Abstract

CORE 1

Appendix 1: Matthews Media Group Final Report

CORE 2

Appendix 1: Publications and Submitted Manuscripts

Appendix 2: Outline of Cost-Effectiveness of BRCA1/2 Counseling and Testing Manuscript

Appendix 3: Quality of Life Library – Sample Data Abstraction Form

Appendix 4: Active and Pending Grants (Year 3)

Appendix 5: Core Consultations

Appendix 6: Core Meeting Minutes and Core Seminar Schedule

DAMD17-96-C-6069

Marc E. Lippman, MD

Principal Investigator

Lombardi Cancer Center

Georgetown University Medical Center

September 30, 1999

PROJECT 3
Appendix 1

A PHASE II EVALUATION OF THALIDOMIDE IN PATIENTS WITH METASTATIC BREAST CANCER. S. Baidas, C. Isaacs, J. Crawford, E. Winer, G. Fleming, L. Harris, J. Pluda, M. Hawkins, M. Lippman, D.F. Hayes. Georgetown University, Washington D.C., Dana Farber, Boston MA, University of Chicago IL, Duke University, Durham NC, NCI-CTEP, Rockville MD. Supported by DOD cancer center grant DAMD 17-96-C-6069.

Angiogenesis is a critical factor for cancer growth and metastasis. Thalidomide is a well tolerated oral agent with antiangiogenic activity in the rabbit corneal micropocket assay. We conducted a phase II study of thalidomide in patients with metastatic breast cancer. The objectives of this study were to compare two dose levels (200 mg vs 800 mg) of thalidomide in regard to efficacy, as measured by time to progression, and safety. Fourteen patients were accrued to each arm. Most patients were heavily pre-treated. On the 800 mg arm, all patients had progressive disease at or before 8 weeks staging. The dose was reduced to 600 mg/day for 5 patients, and to 400 mg/day for 2 patients for extreme somnolence. Dosage for 1 patient was increased to 1000 mg/day and for 4 patients to 1200 mg/day. On the 200 mg arm, 2 patients had stable disease at 8 weeks. They remained on therapy for a further 8 weeks. One of these 2 patients was removed from the study at week 11 due to grade 3 neuropathy and the second had progressive disease at week 16. One patient's dose was decreased to 150 mg/day due to grade 3 neuropathy and then discontinued. The main dose limiting toxicities were somnolence (800 mg arm) and peripheral neuropathy. The other adverse events not requiring dose or schedule modifications included constipation, fatigue, dry mouth, dizziness, nausea, anorexia, headaches, skin rash and neutropenia. In summary no activity was detected at the 800 mg dose level and significant side effects were seen. At the 200 mg dose level, 2 patients had stable disease at 8 weeks and side effects were tolerable. Serum was collected every 2 weeks for pharmacokinetics and growth factors assays. We concluded that single agent thalidomide has little or no activity in this patient population. Further studies, including different patient populations and/or in combination with other agents should be performed at the 200 mg dose level.

Matthews Media Group, Inc.
6101 Executive Boulevard
Suite 300
Rockville, MD 20852
301.984.7191
301.984.7196 (Fax)
www.matthewsgroup.com



Communications and Public Relations

Patient Recruitment

Graphic Design

MEMORANDUM

TO: Jon Kerner, Ph.D.
Associate Professor of Medicine
Associate Director, Cancer
Prevention & Control
Lombardi Cancer Center
Georgetown University

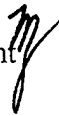
FROM: Molly Matthews, President 
Matthews Media Group

CC: Frances Heilig, MMG
Candice Clark, MMG

SUBJECT: Final Project Report

DATE: September 3, 1999

Jon, this is the final project report for Matthews Media Group's work with the Minority Recruitment to Breast Cancer Clinical Trials Project and the Cancer Assessment and Risk Evaluation (CARE) study for the Lombardi Cancer Center Patient Accession Core. We understand and respect your decision to pursue further CARE research accrual using Lombardi staff, and we wish you well in this approach.

As promised, we are forwarding 1) contact information that will help you transition recruitment activities in-house and 2) a summary of "lessons learned" that may assist in future protocol recruitment efforts. Some of this information has already been provided in memos and meetings, but is compiled here for handy reference.

First, the lessons learned, organized by the recruitment strategies we recommended.

Lessons Learned

As we stated before, the PAC and MMG--each highly experienced in recruiting patients into clinical trials--knew that the recruitment task was challenging. The challenges included: CARE protocol eligibility requirements; negative perceptions of genetic testing among some African Americans and lack of awareness among others, including health professionals; the relatively short recruitment timetable; and the modest contract budget, among other factors.

Targeted outreach, which boils down to effective relationships, offers the surest channel to overcome recruitment challenges. The relationships MMG pursued on behalf of CARE and which should be extended are those with oncology doctors, Chartered Health Plan and community resources.

Oncology Doctors

Lessons Learned:

Aside from a few associated with Georgetown, physicians provided little or no assistance to the CARE project. Both PAC and MMG agree that physician participation is vital in recruitment for a highly specialized protocol such as CARE. However, physician education is as necessary as community education. Because gene testing is still relatively new and controversial, many doctors, including oncologists, express apprehension about referring patients. Additionally, doctors may see participation as a no-benefit drain on their time to counsel and refer their patients to CARE.

Transition:

Continuing Medical Education units offered to educate medical staff on CARE would be useful in bringing more physicians on board.

Physician contact lists are attached for further PAC outreach.

Chartered Health Plan

Lessons Learned:

Collaborative efforts should yield a win/win for each partner. The Chartered Health Plan/CARE collaboration began with high expectations for both partners but didn't deliver enough benefits for Chartered Health. For example—

- We were unable to meet their request to place their logo on the point-of-service displays.
- Lack of an incentive plan for Chartered Health outreach workers.
- Patients who discussed the program with

Transition:

Collaboration must be nourished by high-level contacts. This partnership requires more direct contact from Lombardi, as one strong institutional partner to another.

MMG advised Chartered Health of the recruitment transition and scheduled a meeting between Lombardi and Chartered Health to discuss future CARE activities. A copy of the transition letter sent to Chartered Health and Lombardi is attached.

A CARE representative must be responsible for picking up referrals that are generated by outreach staff each week and talking with the Chartered Health contact to ensure the program is running smoothly. Picking up the referrals weekly and touching base with the partnership director adds a personal touch to the relationship.

The Chartered Health contact is:

Cecile Comrie
Assistant Director
Wellness Programs
(202) 408-2031

Community Outreach

Lessons Learned:

Lombardi should collaborate with organizations interested in health issues to build more relationships with African Americans and other communities of color long-term. In doing community outreach in churches, health centers, breast cancer support groups, and health fairs, MMG noted general lack of awareness of genetic counseling and testing in the African American community. Lombardi can help to increase awareness.

Why does that matter? Because such basic knowledge may make potential referral candidates more receptive when medical professionals approach them about being tested. Currently, there are barriers to participation because--

- Many women don't know their family history on cancer because this is an issue that many family members choose not to share.

- Many women who have survived breast or ovarian cancer believe their “healing” was a blessing from God. Digging into family history unnecessarily may be considered an act against faith in God. Such beliefs play a major role in African American Christian women who would not consider CARE or other research.
- Why does it matter? Many African American churches, as well as other civic/social/cultural organizations, have established health programs; some churches even have health ministries that assure members that good health care is consistent with their faith; i.e., pray and believe but also fully use the health resources available. This message was clearly communicated at an August church event where the CARE speaker was well received and collected 66 family history forms.
- Lombardi is not the first choice of African American women seeking cancer information. For example, Howard University, a community-based research organization, has a similar genetic testing and counseling program, and women of color may be more likely to participate in clinical research in what is considered a more nurturing, familiar environment. George Washington University has also made inroads into the community with its Mammovan and related media efforts.

Transition:

CARE recruitment requires an extensive education campaign to increase the level of awareness among health professionals and the community. Georgetown University as an institution needs to be more active in communities of color to build a level of trust.

Such involvement includes the opportunity to educate African Americans on the importance of participating in research, even when the benefits aren't treatment-related or directly beneficial. Although African American women have a higher rate of breast cancer mortality, they have an overall lower incidence. Many are aware of the importance of mammograms, but not of genetic counseling and testing. Lombardi can help communities understand the relationship of long-range research to advances in individual care.

Next Steps

We hope this summary provides points for further consideration and action to achieve your worthwhile goals. Please feel free to contact Frances Candice or me if you have questions or need additional information. Again, best wishes on the successful conclusion of the CARE project.

Enclosures:

HOSPITAL OUTREACH CONTACT LIST AND UPDATE

Starred hospitals have either agreed to display point-of-purchase or refer eligible patients

Holy Cross Hospital

1500 Forest Glen Rd.
Silver Spring, MD 20910

Contacts:

Evelyn Owuso
Director
Clinical Research Center
(301) 754-7552

Steve Shore
Executive Director
Cancer Program
(301) 754-7000

Status:

Access to patient population denied by the director of the clinical research center. Director presented CARE to several physicians to determine if there was interest in the program. Most physicians were specifically interested in treatment protocols. Collaboration at this time is not feasible.

Southern Hospital

7503 Surratts Rd.
Clinton, MD 20735

Contacts:

Beverly Mitchell
Oncology Nurse
Oncology Department
(301) 877-9681

Status:

A CARE protocol packet was mailed to Beverly Mitchell in May 1999. She agreed to present the CARE program to the Cancer Committee, but has not done so. Several follow-up calls made through the month of July to no avail.

***Shady Grove Adventist Hospital**

9901 Medical Center Drive
2 West / Medical Surgical Oncology
Rockville, MD 20850

Contacts:

Amy Seig/ Susan Heiffer
Nurse Manager
Surgical Oncology
(301) 279-6000

Status:

Amy Seig is responsible for presenting information to the hospital's cancer committee for approval. Made several attempts to contact her to determine level of interest in the CARE program. In the process of doing continuous follow-up calls, Suzanne Heiffer agreed to assist in the recruitment process, and MMG sent another CARE protocol summary and point of service display. Received one referral; referral had no known family history of breast or ovarian cancer.

Washington Adventist Hospital

Contacted Adventist's cancer program and learned hospital does not allow outside access to its cancer patients.

***Suburban Hospital**

8600 Old Georgetown Rd.
Bethesda, MD 20814

Contact:

Barbara Squiller
Clinical Research Associate
(301) 896-3899

Status:

Barbara Squiller agreed to present the CARE program at the hospital's cancer committee meeting in June. Although Ms. Squiller had an interest in the CARE program, she indicated the cancer committee might be apprehensive about participating, which turned out to be the case. However, received permission to place point of service display in the cancer center.

Doctors Community Hospital

Department of Nursing
8118 Good Luck Rd.
Lanham, MD 20706

Contact:

Cheryl Tom-Nelson, RN MSN
Oncology Nurse Educator
(301) 552-8579

Status:

Cheryl Tom-Nelson presented CARE to the hospital's cancer committee in May 1999. Cancer committee was very apprehensive about the CARE program. MMG advised Ms. Tom-Nelson to refer physicians to CARE staff to address the concerns of physicians. Contact also did not want a point of service display mailed to hospital.

Prince Georges Community Hospital

Made several calls to Prince Georges Community Hospital, but staff couldn't cite any cancer programs or outpatient oncology clinics within the hospital. MMG identified hospital-associated oncologists and mailed protocol summaries.

Laurel Regional Hospital

Laurel Regional Hospital has no oncology department or outpatient clinics of any kind and would not be a good referral source.

*Montgomery General Hospital

18101 Prince Phillip Dr.
Olney, MD 20832

Contacts:

Don Kreitlow/ Betty Frye
Director
Clinical Support Services
(301) 774-8725

Status:

Cancer center is no longer operational. After receiving a CARE protocol packet and point of service display, Betty Frye expressed strong interest in referring patients for the CARE program. No referrals have been received.

HOSPITAL-ASSOCIATED ONCOLOGISTS

In addition to hospital outreach, mailed CARE protocol summaries to the following hospital-associated oncologists in July. Follow-up to be done by CARE staff.

1. PHYSICIANS:

Jeremy Cook, MD
Leon Hwang, MD
Eugene Libre, MD
Daniel Rosenblum, MD

ADDRESS:

WRIT Building
104000 Connecticut Ave. #606
Kensington, MD 20895

TELEPHONE NUMBER:

301-942-2212

2. PHYSICIAN:

Shakun Malik, MD

ADDRESS:

Bethesda Medical Building
8218 Wisconsin Ave. #103
Bethesda, MD 20814

TELEPHONE NUMBER:

301-913-9556

3. PHYSICIAN:

Kenneth Miller, MD

ADDRESS:

Camalier Building
10215 Fernwood Rd.
Bethesda, MD 20817

TELEPHONE NUMBER:

301-774-6136

4. PHYSICIAN:

Stephen Newman, MD

ADDRESS:

Montgomery Professional Ctr.
19261 Montgomery Village Ave.
Gaithersburg, MD 20879

TELEPHONE NUMBER:

301-977-2000

5. PHYSICIAN:

Victor Preigo, MD

ADDRESS:

De Paul Building
160 Varnum St. NE #514
Washington, DC 20017

TELEPHONE NUMBER:

202-526-7008

6. PHYSICIAN:

J Garrett Reilly, MD

ADDRESS:

11510 Old Georgetown Rd.
Rockville, MD 20852

TELEPHONE NUMBER:

301-881-3940

7. PHYSICIAN:

Peter Sherer, MD

ADDRESS:

Connecticut Belair Medical Park
3947 Ferrara Dr.
Wheaton, MD 20906

TELEPHONE NUMBER:

301- 946-6420

8. PHYSICIANS:

Martin Wertz, MD
Thomas Bensinger, MD

ADDRESS:

7525 Greenway Ctr. Dr. Suite 205
Greenbelt, MD 20770

TELEPHONE NUMBER:

301-982-9800

9. PHYSICIANS:

David Haidak, MD
Kai-Yiu Yeung, MD

ADDRESS:

8926 Woodyard Rd. Suite 200
Clinton, MD 20735

TELEPHONE NUMBER:

301-868-7911

10. PHYSICIAN:

Lewis Dennis, MD

ADDRESS:

6201 Greenbelt Rd., Suite U-1
College Park, MD 20740

TELEPHONE NUMBER:

301-982-2900

11. PHYSICIAN:

Carolyn Hendricks, MD

ADDRESS:

2101 Medical Park Dr. Suite 210
Silver Spring, MD 20902-4053

TELEPHONE NUMBER:

301 681-5917

12. PHYSICIAN:

Clara Chan, MD

ADDRESS:

9801 Georgia Ave. Suite 337
Silver Spring, MD 20902-5276

PHONE NUMBER:

301-681-4600

CHARTERED HEALTH PLAN CONTACTS

In addition to mailing 175 protocol summaries and 120 point-of-service displays to associated metro-area physicians, called the following oncologists to determine the feasibility of patient referral.

Note: Starred physicians have been contacted with no response to date. The status of physicians that have been successfully contacted are indicated below.

1. PHYSICIAN:

*Robert Buras, MD

ADDRESS:

Georgetown University Medical Center
3800 Reservoir Rd., NW
PHC Bldg., 4th fl.
Washington, DC 20007

TELEPHONE NUMBER:

(202) 687-0481

2. PHYSICIAN:

*Richard Holt, MD

ADDRESS:

D.C. General Hospital
1900 Massachusetts Ave. SE
Washington, DC 20003

TELEPHONE NUMBER

(202) 675- 5647

3. PHYSICIAN:

*Marie Pennanen, MD

ADDRESS:

Georgetown University Medical Center
3800 Reservoir Rd., NW, PHC bldg., 4th Fl.
Washington, DC 20007

TELEPHONE NUMBER:

(202) 687-8595

4. PHYSICIAN:

*Theodore Tsangaris, MD

ADDRESS:

Georgetown University Medical Center
3800 Reservoir Rd. NW
PHC bldg., 4th Fl.
Washington, DC 20007

TELEPHONE NUMBER:

(202) 687-7389

5. PHYSICIAN:

Anatoly Drischillo, MD

ADDRESS:

Georgetown University Hospital
3800 Reservoir Rd., NW
Bles. bldg. Lower Level
Washington, DC 20007

TELEPHONE NUMBER:

(202) 784-3320

6. PHYSICIAN:

Gregory Gagnon, MD

ADDRESS:

GUMC Radiation Medicine
9711 Medical center Dr. Suite 111

TELEPHONE NUMBER:

(301) 762-5595

(Agreed to refer eligible patients)

7. PHYSICIAN:

Anu Gupta, MD

ADDRESS:

GUMC Radiation Medicine
10301 Democracy Ln.
Fairfax, VA 22030

TELEPHONE NUMBER:

(703) 934- 4450

(Agreed to refer eligible patients. Protocol summary must be re-sent)

8. PHYSICIAN:

William Harter, MD

ADDRESS:

Georgetown University Medical Center
Medical Center
3800 Reservoir Rd., NW
Washington, DC 20007

TELEPHONE NUMBER:

(202) 784-3320

(Currently referring eligible patients to CARE)

9. PHYSICIAN:

Michael Keuttal, MD

ADDRESS:

GUMC Radiation Medicine
10301 Democracy Ln.
Fairfax, VA 22030

TELEPHONE NUMBER:

(703) 934-4450

(No longer at location)

10. PHYSICIAN:

Kwok Lee, MD

ADDRESS:

GUMC Radiation Medicine
501 W Seventh St.
Frederick, MD 21701

TELEPHONE NUMBER:

(301) 694-5517

11. PHYSICIAN:

Jefferson Moulds, MD

ADDRESS:

GUMC Radiation Medicine
7501 Surratts Rd., Suite 101
Clinton, MD 20735

TELEPHONE NUMBER:

(301) 868-1100

12. PHYSICIAN:

Catherine Salem, MD

ADDRESS:

GUMC Radiation Medicine
7501 Surratts Rd, Suite 108
Clinton, MD 20735

TELEPHONE NUMBER:

(301) 868-1100

13. PHYSICIAN:

James Sitzman, MD

ADDRESS:

Georgetown University Medical Center
3800 Reservoir Rd., NW,
PHC building, 4th Fl.
Washington, DC 20007

TELEPHONE NUMBER:

(202) 687-0481

(No longer at location).

14. PHYSICIAN:

Paul Sugarbaker, MD

ADDRESS:

Sugarbaker Oncology
Associates P.C.
110 Irving St., NW
Suite CG-185
Washington, DC 20010

TELEPHONE NUMBER:

(202) 877-3908

(Patient population inappropriate for CARE recruitment. Specializes in GI oncology)

15. PHYSICIAN:

*Russell Hill, MD

ADDRESS:

1160 Varnum St., NE
Suite 300
Washington, DC 20017

TELEPHONE NUMBER:

(202) 269- 7121

16. PHYSICIAN:

Fitzroy Dawkins, MD

ADDRESS:

Howard University Physicians, Inc.
Department of Medicine
2041 Georgia Ave., NW
Suite 5100
Washington, DC 20060

TELEPHONE NUMBER:

(202) 865-1511

APPENDIX 1
Publications and Submitted Manuscripts

ARTICLES

Serendipity in Diagnostic Imaging: Magnetic Resonance Imaging of the Breast

William F. Lawrence, Wenchi Liang, Jeanne S. Mandelblatt, Karen F. Gold,
Matthew Freedman, Susan M. Ascher, Bruce J. Trock, Polun Chang

Background: Magnetic resonance imaging (MRI) of the breast has been proposed as a noninvasive diagnostic test for evaluation of suspicious ("index") lesions noted on mammography and/or clinical breast examination (CBE). However, women may have incidental ("serendipitous") lesions detected by MRI that are not found on mammography or CBE. To understand better whether or not biopsy procedures should be performed to evaluate serendipitous lesions, we estimated the breast cancer risk for women with this type of lesion. **Methods:** A decision analysis model was used to estimate the positive predictive value (i.e., the chance that a woman with a serendipitous lesion has cancer) of MRI for serendipitous lesions in women who had an abnormal mammogram and/or CBE suspicious for cancer (where a biopsy procedure is recommended). We restricted the analysis to data from women whose index lesions were noncancerous and used meta-analysis of published medical literature to determine the likelihood ratios (measures of how test results change the probability of having cancer) for MRI and the combination of CBE and mammography. The positive predictive value of MRI was calculated using the U.S. population prevalence of cancer (derived from registry data) and the likelihood ratios of the diagnostic tests. **Results:** Under a wide variety of assumptions, the positive predictive value of MRI was extremely low for serendipitous lesions. For instance, assuming sensitivity and specificity values for MRI of 95.6% and 68.6%, respectively, approximately four of 1000 55- to 59-year-old women with serendipitous lesions would be expected to have cancer (positive predictive value = 0.44%, 95% confidence interval = 0.24%–0.67%). **Conclusion:** In women with a suspicious lesion discovered by mammography and/or CBE that is found to be benign, serendipitous breast lesions detected by MRI are extremely unlikely to represent invasive breast cancer. Immediate biopsy of such serendipitous lesions may, therefore, not be required. [J Natl Cancer Inst 1998;90:1792–800]

Mammography and clinical breast examination (CBE) are the current standard measures for breast cancer screening and initial evaluation of breast signs and symptoms. The combination of mammography and CBE has a moderate sensitivity and high specificity for breast cancer. However, the positive predictive value of these tests for cancer, especially when done for screening and in young women, may be quite low, due to a low prior

probability of cancer. For example, in a large Canadian screening study, only 12% of women aged 40–49 years who were recommended to have a biopsy procedure as a result of an abnormal screening mammogram or CBE actually had breast cancer (1). An estimated 600 000 breast biopsies are performed annually in the United States (2); as many as 85% of these yield benign results (3–6). Thus, the potential economic and quality-of-life (7–12) impact of alternative diagnostic pathways could be substantial.

To reduce the number of biopsies performed on women who will ultimately be diagnosed with benign lesions, several intermediate diagnostic tests have been proposed (13,14). Such tests would need to have high sensitivity, so that there are few missed cancers, and ideally also have high specificity, so that women without breast cancer would not be required to undergo an unnecessary invasive procedure.

One test currently under investigation as an intermediate diagnostic test is magnetic resonance imaging (MRI) of the affected breast. Studies suggest that MRI will be quite sensitive but may not be very specific, with specificity as low as 30% (15). Also, MRI of the breast has been reported to show breast lesions not found on either the initial mammogram or CBE. We refer to these lesions as "serendipitous lesions"—lesions found incidentally in the work-up of another breast lesion (16). These lesions raise a diagnostic dilemma: If the MRI has a higher sensitivity than conventional procedures, then cancer, if present, would be more likely to be detected by the MRI than the mammogram; on the other hand, if the specificity is truly much lower, then these serendipitous lesions are much more likely to be false-positive lesions than if they were originally found on mammography or CBE. In addition, localizing these lesions for biopsy procedure would be quite difficult if other diagnostic modalities cannot detect them; in this case, an MRI-guided biopsy procedure may be necessary to ensure localization of the lesion.

Affiliations of authors: W. F. Lawrence, W. Liang, J. S. Mandelblatt, K. F. Gold (Cancer Clinical and Economic Outcomes Core, Lombardi Cancer Center), M. Freedman, S. M. Ascher (Department of Radiology), B. J. Trock (Molecular Epidemiology, Lombardi Cancer Center), Georgetown University Medical Center, Washington, DC; P. Chang, Institute of Public Health, National Yang-Ming University, Taipei, Taiwan.

Correspondence to: William F. Lawrence, M.D., M.S.I.E., Cancer Clinical and Economic Outcomes Core, Lombardi Cancer Center, Georgetown University Medical Center, 2233 Wisconsin Ave., Suite 430, Washington, DC 20007 (e-mail: lawrencw@gunet.georgetown.edu).

See "Notes" following "References."

© Oxford University Press

If the suspicious lesion that prompted MRI evaluation is found to be benign, what should be done diagnostically to evaluate these serendipitous breast lesions found on MRI? Using decision analysis and the best estimates from a comprehensive literature review, we estimate the positive predictive value of these serendipitous lesions found on MRI or the probability that women with serendipitous lesions truly have invasive breast cancer. These data, while preliminary, provide clinicians and patients with a framework for deciding on the appropriate work-up of unexpected breast lesions found by MRI.

METHODS

There are no published data that specifically address the question of risk of cancer in a serendipitous MRI lesion detected in the course of diagnostic evaluation of another abnormality on mammogram and/or CBE (the "index lesion"). We restrict our analysis to the situation where the index lesion is not malignant and calculate the probability that a woman with a serendipitous lesion has cancer based on biopsy results for the index lesions, age, race, and degree of cancer risk. Women with malignant index lesions are excluded from this analysis.

Decision Model

We used standard decision-analytic techniques (17) to model the sequence of events leading to the finding of a serendipitous lesion on MRI of the breast and to estimate the probability of cancer in the serendipitous lesion. We used a computer spreadsheet (Microsoft Excel v. 5.0 for Windows; Microsoft, Inc., Redmond, WA) for model construction.

As noted above, we define the index lesion as the lesion found on mammogram and/or CBE that prompted a recommendation for biopsy procedure and further evaluation. A serendipitous lesion represents a lesion seen on MRI that was not suspected by either the index mammogram or CBE.

The conceptual approach to the construction of the model is shown in Fig. 1. A woman having a biopsy procedure for the index lesion will either have a benign or a malignant lesion. We assume that if the index lesion is malignant, the clinician may wish to pursue the serendipitous lesions for the possibility of a multicentric cancer, and these women are excluded from this analysis. If the woman has an index lesion that is benign, we assume that her initial probability of cancer is the U.S. population average for her age and race. We also assume that the woman does not have a personal history of breast cancer; this history could raise her initial probability of disease. By definition, the mammogram and the CBE for this woman were negative in the area of the serendipitous lesion, which lowers the probability of cancer. Her probability of cancer given these prior negative tests is calculated using a Bayesian revision of probability (17) and is influenced by her probability of cancer before the test and the sensitivity and specificity of the index mammography and CBE. The positive MRI raises her probability of cancer; this probability is affected by the sensitivity and specificity of MRI. Thus, overall, our model calculates the probability of cancer given the positive MRI, a negative mammogram and CBE, and the initial probability of disease for women of different ages and races.

Model Parameters

We estimated three parameters for this model: the likelihood ratio positive of MRI, the likelihood ratio negative of the combination of mammography and CBE, and the initial prevalence of breast cancer. The likelihood ratio positive is the ratio of sensitivity to one minus the specificity and represents the degree to which a positive test raises the odds of diagnosis. The likelihood ratio negative is the ratio of one minus the sensitivity to specificity and represents the degree to which a negative test lowers the probability of disease. Meta-analyses were conducted to estimate the likelihood ratios of MRI and mammography and CBE. Meta-analysis is a technique that can be used to summarize the results of good-quality studies (18-23) performed in diverse settings and populations. Such analyses are useful for new diagnostic tests, such as MRI, when no one study has sufficient power to address a particular question, and for summarization of the data across multiple studies on potentially different populations with different diagnostic thresholds for a positive test.

Sensitivity and specificity of MRI. Data for the sensitivity and specificity of breast MRI, used to calculate the likelihood ratio positive, came from the pub-

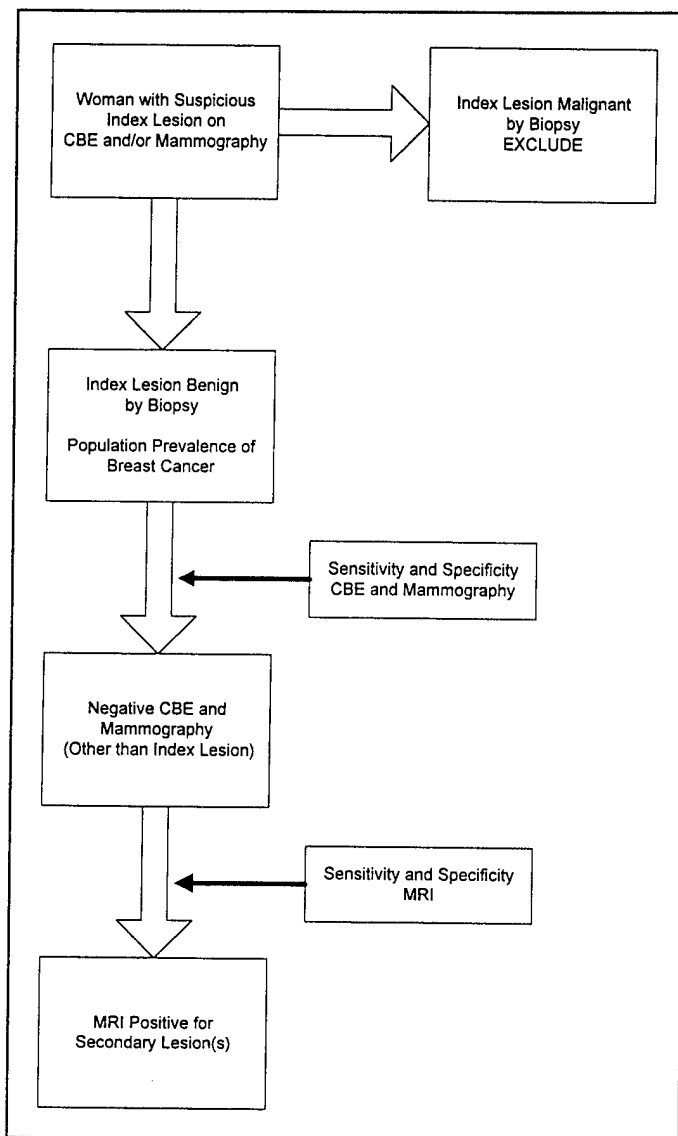

Fig. 1. Algorithm for calculating the positive predictive value of serendipitous breast magnetic resonance imaging (MRI) lesions. CBE = clinical breast examination.

lished medical literature. We performed a MEDLINE® (National Library of Medicine) search, from 1990 through 1997, using the terms "magnetic resonance imaging" and "breast neoplasms." We also searched references of relevant articles. Inclusion criteria for the abstraction of data from an article included the following: 1) sample size of 10 or greater; 2) data were available on MRI and breast cancer results; 3) the study sample consisted of women at risk for cancer, defined as having a suspicious finding on CBE and/or mammogram, but without known cancer at study entry; 4) the MRI readers were blinded to the final diagnosis; and 5) the article was written in English. We did not exclude articles in which the MRI readers had access to mammography or clinical examination data, since we assumed that in clinical practice the MRI reader would review these data when reading the MRI. For studies eligible for inclusion, the following data were abstracted: study design; patient selection; number and age of subjects; method for MRI; method for diagnosing breast cancer; and numbers of true-positive, false-positive, true-negative, and false-negative MRI results. Although this study is concerned with the diagnosis of invasive breast cancer, we include the diagnosis of ductal carcinoma *in situ* (DCIS) as a true-positive diagnosis for the purposes of calculating the sensitivity and specificity of MRI. This assumption results in a higher positive predictive value of MRI than would not including DCIS as a true-positive result; assuming otherwise would result lower the specificity of MRI, lowering the positive predictive value. Data could

not be found on the diagnostic accuracy of MRI in specific areas of the breast where the mammogram and CBE were negative. Thus, we assume that the sensitivity and specificity of MRI for the detection of breast cancer are the same for serendipitous lesions as they are for index lesions. Given the paucity of age-specific data, we also assume that the diagnostic accuracy of MRI is independent of age.

Sensitivity and specificity of mammography and CBE. Data for the diagnostic characteristics of CBE and mammogram were derived from the four major randomized trials of breast cancer screening that employed both CBE and two-view mammography (1,24-26). Although only one of these studies was conducted in the United States, we assume that the sensitivity and specificity of mammography and CBE are independent of the country in which the study was performed. Similar to MRI, data from these studies were abstracted to define true-positive, false-positive, true-negative, and false-negative results. We used the detection method (27) to calculate sensitivity of mammography and CBE. True positives were defined as screening-detected cancers, whether found by mammogram, CBE, or both. False negatives were defined as those who were diagnosed as having breast cancer in the interval between screening tests. False positives were defined as those participants undergoing biopsies for benign lesions. True negatives were those who did not clinically develop cancer during the study follow-up period. While probably not strictly true (28), we make the simplifying assumption that CBE and mammography combined test accuracy is independent of age. We examine this assumption in sensitivity analysis by calculating the effects of lower sensitivity for mammography and CBE for women under 50 years of age. While mammography may be less sensitive in this age group, these women also have a low prior probability of cancer. We also assume that the diagnostic accuracy of CBE and mammography is conditionally independent of that of MRI, conditioned on the presence or absence of cancer (29). Thus, for example, if a woman has cancer and a positive MRI, her probability that the CBE and/or mammogram are positive is the same as it would be if she had cancer but a negative MRI.

Breast cancer prevalence. Yearly incidence rates of breast cancer will underestimate breast cancer prevalence since not all breast cancer will be detected in the year following the onset of the cancer. Data for the baseline prevalence of undiagnosed breast cancer in the U.S. population were derived from a simulation model of the natural history of breast cancer (30,31). This model uses breast cancer incidence data from the Surveillance, Epidemiology, and End Results (SEER)¹ registry (32) as well as U.S. population data (33) to estimate the prevalence of cancer by age, race [as reported by Ries et al. (32): black, white, and total population], and incidence rate. We estimate prevalence of invasive breast cancer only; our data do not include the prevalence of DCIS in the population. Data from this model have been validated against Wisconsin and Iowa tumor registry data (30). That model was used to calculate a ratio of detected disease to undetected disease. Using this ratio, we then estimated the age- and race-specific prevalence of disease. We also calculated prevalences for "high-risk" women, using twice the average U.S. population incidence rates to represent those at high risk. We use this high-risk estimate to approximate the increased risk of having a first-degree relative with breast cancer (34-41) or of having previously had a biopsy showing benign breast disease (42-45).

Analysis

Meta-analysis. Using data from the literature of the sensitivity and specificity of the tests, we converted these data into likelihood ratios and pooled the data across studies using an analogue of a Mantel-Haenszel estimator. We use the ratio of the average sensitivities and complements of specificities to preserve the roles of the sensitivity and specificity in the calculation of the likelihood ratio in the estimator, and because this estimator is the closest analogue of the Mantel-Haenszel estimator of odds ratios (46). The estimator for the likelihood ratio positive for MRI (LR_{MRI+}) was calculated using the formula:

$$LR_{MRI+} = \frac{\left. \sum_{i=1}^{12} \frac{TP_i}{TP_i + FN_i} \right\} \text{ sensitivity}}{\sum_{i=1}^{12} \left[1 - \frac{TN_i}{TN_i + FP_i} \right] (1 - \text{specificity})}$$

where TP_i is the number of true-positive diagnoses for study i , FN_i is the number

of false negatives, TN_i is the number of true negatives, and FP_i is then number of false positives. The likelihood ratio negative for the combination of mammography and CBE ($LR_{MAM,CBE-}$) was calculated in a similar fashion (see below). We obtained the 95% confidence intervals (CIs) by using jackknife estimation and recalculating likelihood ratios, leaving one study out for each study in the analysis (47). The standard errors (SEs) of the means of the likelihood ratios (\overline{LRs}) were calculated using the following formula:

$$SE = \sqrt{\frac{n}{n-1} \times \sum_{i=1}^n [LR_i - \overline{LR}]^2}$$

where n is the number of studies in the analysis, and LR_i is the recalculated likelihood ratio leaving out study i . The 95% CIs were then calculated by:

$$95\% \text{ CI} = \overline{LR} \pm 1.96 \times SE.$$

Independent estimation of sensitivity and specificity of a diagnostic test using Mantel-Haenszel meta-analytic methodology may underestimate true sensitivity and specificity (48). Thus, we performed the meta-analysis on the likelihood ratios, to recognize the interdependence of these two measures of accuracy. Since underestimation of the sensitivity and specificity of MRI would result in an underestimation of the probability of disease given a positive MRI, we also examined the sensitivity and specificity of this test using the technique of the summary receiver-operating characteristic curve (48). This technique creates a receiver-operating characteristic (ROC) curve based on sensitivity and specificity data from multiple studies. This technique has the advantage, similar to our method of estimating likelihood ratios, of recognizing the interdependency of sensitivity and specificity. We also use this technique to test for homogeneity of the different MRI studies, looking for outliers on the summary ROC curve.

Positive predictive value of MRI. The probability of having cancer given a negative mammogram and CBE but positive MRI (the post-test probability) was calculated using the following equations:

$$\text{Post-test odds} = \text{pre-test odds} \times LR_{MAM,CBE-} \times LR_{MRI+}$$

where

$$\text{Pre-test odds} = \frac{\text{pre-test probability}}{1 - \text{pre-test probability}}$$

and post-test odds are converted to probability using the formula:

$$\text{Post-test probability} = \frac{\text{post-test odds}}{1 + \text{post-test odds}}$$

The post-test probability represents the positive predictive value of MRI given that the mammogram and CBE were negative in the area of the suspicious lesion found on MRI. We use a person-level analysis to calculate the positive predictive value of MRI as opposed to a lesion-level analysis; thus, the positive predictive value represents the probability that the woman has cancer given an MRI finding of a serendipitous lesion or lesions.

Monte Carlo simulations. We use Monte Carlo (49) stochastic simulations to calculate two-sided CIs for the positive predictive value of MRI, given starting age, race, and given that the mammogram, CBE, and index lesion biopsy are negative. In this simulation technique, each uncertain parameter (e.g., the likelihood ratio positive of MRI) is represented by a random variable that is chosen from a probability distribution reflecting the degree of uncertainty for that parameter. We used normal probability distributions to represent the three parameters in the model, each distribution was constrained to avoid illegal values. The probability of breast cancer and likelihood ratio negative of CBE and mammography were bounded between zero and one; the likelihood ratio positive for MRI was bounded as greater than or equal to one. The model was recalculated 5000 times

Table 1. Model parameters*

Parameter	Value	95% confidence interval†
Sensitivity of mammography and CBE	82.2%	
Specificity of mammography and CBE	98.8%	
Likelihood ratio negative of mammography and CBE‡	0.18	0.12–0.24
Sensitivity of MRI	95.6%	
Specificity of MRI	68.6%	
Likelihood ratio positive of MRI§	3.05	2.00–4.11

*CBE = clinical breast examination; MRI = magnetic resonance imaging.

†Confidence intervals are shown only for the likelihood ratios, the parameters used in the study.

‡The likelihood ratio negative is defined as the ratio of one minus sensitivity to specificity.

§The likelihood ratio positive is defined as the ratio of sensitivity to one minus specificity.

for each set of parameters using a Monte Carlo simulation software package (@Risk version 3.0 for Windows; Palisade Corp., Newfield, NY). The 95% CIs for the likelihood ratios are shown in Table 1.

Sensitivity analyses. To test the effects of uncertainty in model parameters on model results, we performed several sensitivity analyses. These analyses involve varying the model parameters over a range of values. We performed sensitivity analyses on the initial prevalence of disease, the sensitivity and specificity of mammography and CBE, and the sensitivity and specificity of MRI. We also examined the effect of assuming that the combined sensitivity of mammography and CBE was lower for younger women than for older women, using an approximate ratio of sensitivity of mammography in younger women to that of older women based on the medical literature (28,50–53).

RESULTS

Meta-analyses

The results of the literature search for the MRI parameters revealed 360 MEDLINE entries identified, of which 14 met eligibility criteria for use in the meta-analysis. After removal of duplicated data, we used 12 studies in the meta-analysis; these studies are summarized in Appendix Table 1. Sensitivity of the studies ranged from 91% to 100%. The studies showed a wide range of specificity, ranging from 37% to 89%.

Parameter estimates for the likelihood ratios used in the analysis are shown in Table 1. The sensitivity and specificity for mammography and CBE and for MRI are included for reader information; the likelihood ratios were used for the model analyses. As can be seen in Table 1, the summary measure of sensitivity of MRI is quite high, but that of specificity is modest. The summary likelihood ratio positive for MRI, 3.05, is reasonably small. In comparison, the likelihood ratio positive of mammography and CBE would be 68.5, due to the very high specificity of the combination of these two tests.

Fig. 2 shows the summary ROC curve for the MRI studies along with the operating points of these studies. The curve shown is a partial ROC curve to avoid extrapolation past the range of available data. While we combined studies using different MRI techniques, no study was an outlier on the regression used to create the curve, suggesting that no study was operating at a sensitivity and specificity significantly different from those combinations on the summary ROC curve.

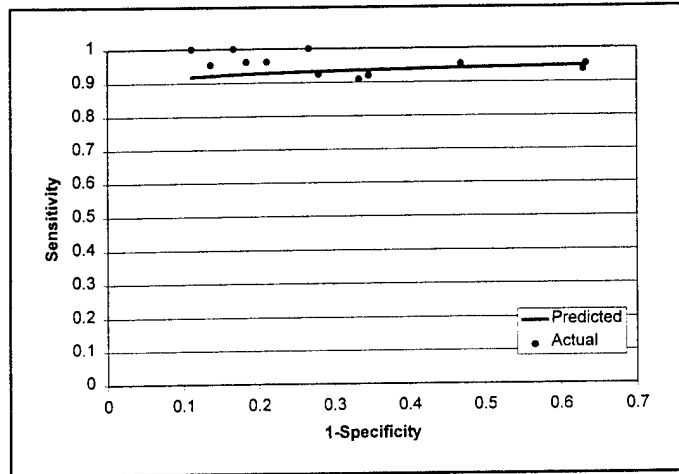

Fig. 2. Summary receiver-operating characteristic curve for magnetic resonance imaging (MRI) of the breast. This curve represents a weighted summary of the studies on the diagnostic accuracy of MRI for the detection of breast cancer.

Simulation Model Results

Table 2 shows the calculated initial prevalence of disease for the overall population, whites, blacks, and women at high risk. These figures represent roughly three times the SEER yearly incidence of disease. Among women having an abnormal mammogram (American College of Radiology categories 4 and 5) (54) and/or CBE who are recommended to have a biopsy procedure, where that biopsy is negative for cancer, the estimated positive predictive values of serendipitous lesions found on MRI are listed in Table 3. For our baseline analysis, the product of the likelihood ratio negative of mammography and CBE and the likelihood ratio positive of MRI is less than one. As a result, the age- and race-specific positive predictive values of MRI for serendipitous lesions are actually smaller than the initial prevalences of cancer shown in Table 2. Positive predictive values range from less than 1% chance of disease up to a high estimate of a 1.9% chance of cancer in an MRI lesion found in an 80-year-old high-risk woman. In general, the positive predictive value of MRI increases with age (Table 3). Older blacks tend to have a lower positive predictive value than older whites (although the CIs overlap), but the positive predictive values for blacks and whites under age 60 years are reasonably similar.

Table 2. Estimated age- and race-specific prevalence of breast cancer*

Age, y	Total, %	White, %	Black, %	High risk, %†
35–39	0.24	0.24	0.25	0.53
40–44	0.40	0.40	0.44	0.84
45–49	0.63	0.64	0.65	1.40
50–54	0.68	0.70	0.60	1.37
55–59	0.79	0.81	0.74	1.58
60–64	0.98	1.03	0.82	1.95
65–69	1.17	1.23	0.98	2.34
70–74	1.42	1.48	1.17	2.85
75–79	1.53	1.58	1.27	3.06
≥80	1.67	1.73	1.30	3.34

*Values expressed as a percentage; 1% would be equivalent to 1000 cancer cases per 100 000 women.

†A high-risk population is defined for this analysis as a population that has twice the age-specific incidence of breast cancer compared with the U.S. total population incidence.

Table 3. Age- and race-specific positive predictive values for cancer (with 95% confidence intervals [CIs]) for women with a serendipitous breast lesion found on MRI and a benign index lesion

Age, y	Predictive value, % (95% CI)			
	Total	White	Black	High risk*
35-39	0.13 (0.07-0.21)	0.13 (0.07-0.20)	0.14 (0.07-0.22)	0.29 (0.16-0.46)
40-44	0.22 (0.12-0.35)	0.22 (0.12-0.35)	0.24 (0.13-0.38)	0.46 (0.25-0.73)
45-49	0.35 (0.19-0.55)	0.35 (0.19-0.55)	0.36 (0.20-0.55)	0.78 (0.43-1.2)
50-54	0.38 (0.21-0.58)	0.39 (0.21-0.60)	0.33 (0.18-0.51)	0.76 (0.42-1.2)
55-59	0.44 (0.24-0.67)	0.45 (0.25-0.68)	0.41 (0.22-0.63)	0.88 (0.48-1.3)
60-64	0.54 (0.30-0.83)	0.57 (0.31-0.88)	0.45 (0.25-0.70)	1.1 (0.59-1.7)
65-69	0.65 (0.34-0.99)	0.68 (0.37-1.1)	0.54 (0.29-0.84)	1.3 (0.71-2.0)
70-74	0.78 (0.44-1.2)	0.82 (0.45-1.3)	0.65 (0.35-0.99)	1.6 (0.88-2.4)
75-79	0.84 (0.46-1.3)	0.87 (0.49-1.3)	0.70 (0.39-1.1)	1.7 (0.94-2.6)
≥80	0.93 (0.51-1.4)	0.96 (0.52-1.5)	0.72 (0.39-1.1)	1.9 (1.0-2.9)

*A high-risk population is defined for this analysis as a population that has twice the age-specific incidence of breast cancer compared with the U.S. total population incidence.

Sensitivity Analyses

Cancer prevalence. The relationship between the initial prevalence of cancer and the positive predictive value of MRI given a negative mammogram and CBE is shown in Fig. 3. Under our baseline conditions of diagnostic accuracy, the positive predictive value of MRI for a serendipitous lesion is less than the starting prevalence of cancer. This finding is explained by the fact that, under our baseline estimates of diagnostic accuracy, the finding of a negative mammogram and CBE lowers the probability of disease more than the finding of a positive MRI raises the probability.

Sensitivity and specificity of MRI. Fig. 4 shows a graph of

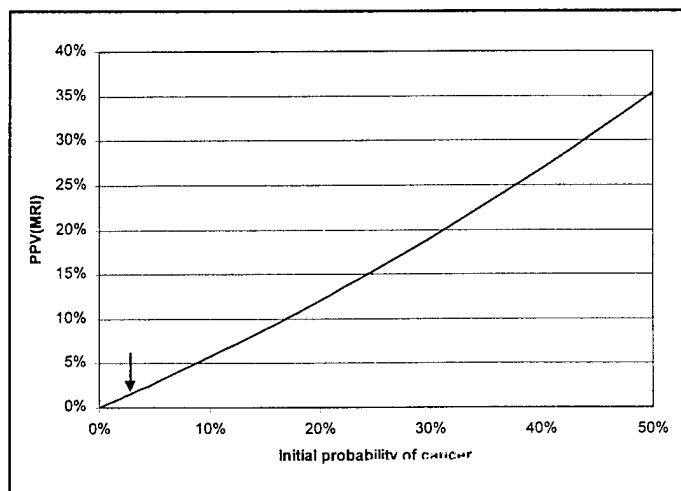

Fig. 3. Sensitivity analysis of the effect of initial prevalence of cancer on the positive predictive value (PPV) of magnetic resonance imaging (MRI), given a negative mammogram and clinical breast examination. The arrow marks the upper bound of the range of initial prevalences of cancer presented in Table 2.

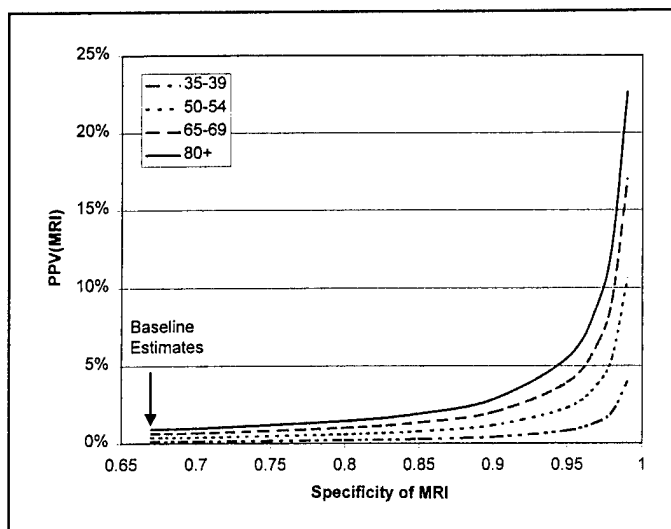

Fig. 4. Sensitivity analysis on the effect of specificity of magnetic resonance imaging (MRI) on the positive predictive value (PPV) of MRI, given a negative mammogram and clinical breast examination. Data are presented for four age groups of women at average population age-specific risk of breast cancer.

the specificity of MRI (for a constant sensitivity) versus the positive predictive value of the MRI, given a negative mammogram and CBE, for selected age groups. For women of all ages, if the specificity of MRI were lower than our baseline estimate, then the positive predictive value of the test would be lower; If the specificity of MRI were to improve, then the positive predictive value of the test would improve. For example, for an average 60-year-old woman to have a 5% chance of cancer with a positive MRI in this setting, the specificity of MRI would have to be more than 95%. For all ages for women at average population risk, the specificity of MRI would need to be at least 94% to raise the positive predictive value to 5%. Improving the sensitivity of MRI will also slightly improve the positive predictive value, but the analysis is not as dependent upon this parameter. We also varied the likelihood ratio positive of MRI across the range of values represented in the summary ROC curve in Fig. 2, bounded by the range of specificities seen in the analyzed studies. If the most specific point on the summary ROC curve is used, the likelihood ratio positive for MRI is 8.3, and the product of the likelihood ratios would be 1.5. Thus, if future use of MRI for a particular finding demonstrated a sensitivity and specificity at this point on the curve (92% and 89%, respectively), the positive MRI could raise the probability of cancer, for example from a pre-test probability of 1.5%–2.3% for a 75-year-old average woman in the population.

Sensitivity and specificity of mammography and CBE.

Fig. 5 shows a graph of the relation between the sensitivity of mammography and the positive predictive value of MRI. If mammography were more sensitive than our baseline estimate of 82%, the positive predictive value of MRI would be lower than estimated. As sensitivity of mammography and CBE decreases, the positive predictive value of the MRI increases, although even with a sensitivity of 40% for mammography and CBE, the positive predictive value of MRI does not reach 5% for average risk women. If the specificity of mammography and

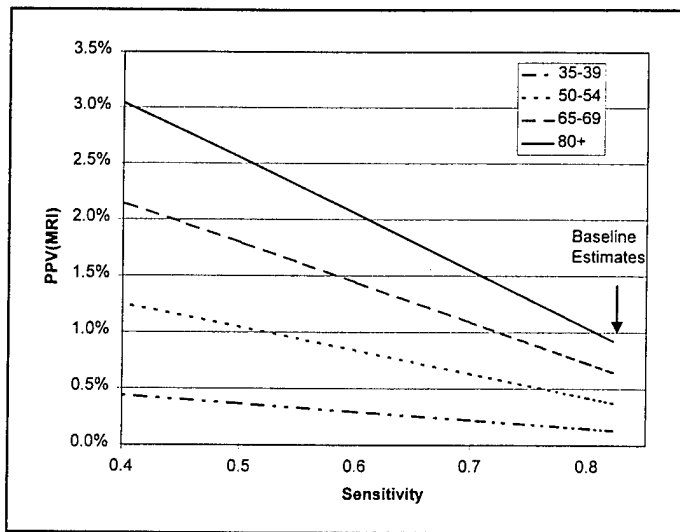

Fig. 5. Sensitivity analysis on the effect of sensitivity of mammography and CBE on the positive predictive value (PPV) of magnetic resonance imaging (MRI). Data are presented for four age groups of women at average population age-specific risk of breast cancer.

CBE decreases, then the positive predictive value will improve, although the analysis is much less dependent on changes in this value. We also examined the effect of our assumption that the sensitivity of mammography and CBE are independent of age. In this sensitivity analysis, we assumed that the combined sensitivity of mammography and CBE for woman younger than 50 years old was 0.8 times our baseline sensitivity. This assumption did not cause large changes; the positive predictive value of MRI ranged from 0.3% for an average 35- to 39-year-old woman to 1.5% for a 45- to 49-year-old high-risk woman. The product of the likelihood ratios for this sensitivity analysis was 1.1; so the combination of negative mammography and CBE did not largely raise the probability of disease for these women whose initial prevalence of disease is small.

DISCUSSION

We know of no other work that focuses on the issue of serendipitous breast lesions in women without known cancer. This work was initiated to help guide clinicians who were faced with decisions of whether or not to pursue serendipitous breast lesions found on MRI.

Our analysis has shown that the positive predictive value for cancer of serendipitous lesions found on MRI is quite low. There are several reasons that MRI has such low positive predictive values. First, the positive predictive value is affected by the probability of disease in the women who undergo the test. Overall, the general population prevalence of cancer is low.

Second, the mammogram and CBE add information to the MRI. The mammogram and CBE are, by definition, negative in the area that the serendipitous lesion was found. The fact that these two tests are negative lower the probability that a woman has cancer from her baseline. Our baseline estimates of the sensitivity and specificity of mammography and CBE suggest that the probability of cancer after these tests are negative is roughly one fifth the initial chance of cancer.

Finally, the lack of specificity of MRI contributes to the low

positive predictive value of this test. For our baseline estimates of diagnostic accuracy, the specificity of MRI would have to be 83% to have a positive predictive value of MRI for a serendipitous lesion equal to the initial prevalence of cancer. While the studies we examined uniformly reported sensitivity more than 90% for MRI, the specificity of MRI ranged from 37% (55,56) to 89% (57). We have found on meta-analysis that the specificity is quite low; however, should future MRI techniques preserve current sensitivity while greatly improving specificity, then the positive predictive value may become high enough to warrant an immediate biopsy procedure for further evaluation. If the sensitivity of future techniques is similar, then the positive predictive values for serendipitous lesions found using these MRI techniques can be approximated by finding the appropriate value for a woman's age and the technique's specificity on the graph in Fig. 4.

Sensitivity analyses show that the probability of cancer in these serendipitous lesions remains extremely low over a wide range of assumptions. As noted above, the analysis was perhaps most dependent on the specificity of MRI, with higher positive predictive values for higher specificity. However, to have the positive predictive value for a 50-year-old woman raised to 5%, for example, the specificity of MRI would have to be 98% given our baseline estimate of sensitivity. Also, the lower the sensitivity of mammography and CBE combined, the better the positive predictive value of MRI; however, the sensitivity of mammography and CBE would have to be 55% for MRI to have a positive predictive value of 1% for 50- to 54-year-old average-risk women.

There are several caveats that should be considered when evaluating our results. First, while our results are based on the best estimates of MRI performance from currently available medical literature, none of the studies specifically address MRI characteristics for incidental lesions. Ideally, future research would include a multicenter, consecutive case series in which all patients with serendipitous lesions and benign index lesions either had an excisional biopsy, an MRI-guided biopsy procedure, or close clinical follow-up to determine the probability of cancer in these serendipitous lesions.

Second, we are currently unable to test the validity of the assumptions underlying this model. However, over a broad range of assumptions, our conclusions that MRI has a very low positive predictive value for serendipitous lesions do not change.

Third, we use a person level analysis, instead of a lesion level analysis. We use this level of analysis to calculate the probability that a woman with a serendipitous finding has cancer, instead of the probability that an individual lesion has cancer. Although we are more interested in the former probability, it is difficult to estimate whether a systematic bias is introduced for women with multiple serendipitous lesions due to lack of data on the risk of cancer with multiple serendipitous lesions compared with a single lesion. If each lesion were statistically independent, then our results, which present data for an average woman with serendipitous lesions, would overestimate the probability of cancer in women with a single serendipitous lesion and underestimate the probability for women with multiple lesions. If the risk of cancer in each of multiple lesions is highly correlated, then the probability of cancer will be similar, regardless of the number of lesions.

Fourth, we are interested in the probability of finding invasive breast cancer in this study; we do not include DCIS in the calculation for positive predictive value. Many women who are diagnosed with DCIS by biopsy do not develop invasive breast cancer (58), although if DCIS is diagnosed then treatment is recommended (59). While the incidence of diagnosed DCIS is currently less than that of invasive cancer (32), an autopsy study (60) suggests that the prevalence of undetected DCIS may be larger than that of undetected invasive cancer. Thus, if DCIS were included, the positive predictive value of MRI would increase over our estimates due to an increase in the pretest probability of having disease, albeit by including lesions of more questionable significance than invasive cancers.

These results apply to women who are "typical members of the population." We include high-risk women, e.g., someone with a strong family history of cancer or with a previous history of a biopsy for benign breast disease. This analysis does not apply to someone for whom there is a very high prior probability of cancer. Excluded from this analysis would be women who have a BRCA1 or BRCA2 breast cancer genetic susceptibility mutation, which put women at much higher lifetime risk of cancer than those with a family history but without a susceptibility mutation (61,62). Also excluded in this analysis are those women who have a high clinical suspicion of having a cancer; for instance, if the serendipitous lesion were found in a woman who is being worked-up for findings suspicious for metastases in other organs or a woman who has known breast cancer or prior

breast cancer, the results of this analysis would not be applicable. Also, this analysis is specific to one point in time. There are currently no data on the positive predictive value of MRI for lesions that change over time. Lesions increasing in size on follow-up MRI, for example, may have a higher probability of being cancer than the one-time finding of a serendipitous lesion modeled here.

Finally, the optimal threshold positive predictive value for cancer for which a biopsy procedure of a suspicious lesion should be performed is not well established. This threshold probability would be dependent on a full evaluation of the risks and benefits of a biopsy procedure, for example, balancing the risks of an invasive procedure versus the consequences of potentially delaying diagnosis of a cancer. We provide the probabilities shown in Table 3 as data to assist clinicians and patients in making decisions about further evaluation of serendipitous MRI lesions. The results of this analysis indicate that the probability that a woman with serendipitous lesions found on MRI has breast cancer is lower than the approximately 15%–35% probability of finding cancer in women currently undergoing a biopsy procedure (3–6). Thus, it is unlikely that an immediate biopsy procedure would be the most beneficial strategy.

In summary, we have found that, in women with a suspicious lesion on mammogram and/or CBE found to be benign, serendipitous breast lesions found on MRI are extremely unlikely to be malignant. While the risk is certainly not zero, for a typical woman the probability of cancer in these lesions is low enough that an immediate biopsy procedure could be avoided.

Appendix Table 1. Summary of magnetic resonance imaging (MRI) studies* used in analysis

Year	Study (reference No.)	Level of analysis†	Sensitivity, %	Specificity, %	No. of patients	Contrast MRI techniques‡			Pre- and post-contrast comparison
						Precontrast	Dynamic imaging	Postcontrast	
1993	Cross et al. (55)	Lesion	95	37	41	RODEO	No	RODEO	No
1993	Harms et al. (56)	Lesion	94	37	30	RODEO	No	RODEO	No
1994	Boetes et al. (63)	Lesion	95	86	83	3D MP-RAGE	Turbo T1 SGE (60)	No	Subtraction
1994	Gilles et al. (64)	Person	95	53	144	T1 spin-echo	T1 spin-echo (6)	T1 spin-echo	Subtraction
1994	Turket et al. (65)	Lesion	100	83	35	T2 spin-echo; T1 spoiled GRASS	T1 spoiled GRASS (8)	3D T1 spoiled GRASS	No
1995	Stomper et al. (66)	Lesion	92	65	49	T1; T2 spin-echo; T1 SPGR	T1 SPGR (10)	No	Subtraction
1996	Heiberg et al. (67)	Lesion	100	73	56	25 patients: T1; T2 31 patients: 3D SPGR	3D SPGR (8)	No	Subtraction
1996	Obdeijn et al. (68)	Person	91	67	54	STIR	2D T1 SGE (3)	STIR	Subtraction
1996	Perman et al. (57)	Lesion	100	89	28	T1 Full Fourier	T1 Full Fourier 3D Dynamic Half Fourier (6)	No	No
1997	Bone et al. (69)	Breast	92	72	220	3D T1 SGE	No	3D T1 SGE	No
1997	Helbich et al. (70)	Lesion	96	82	66	65 patients: T2; 3D T1 SGE 3 patients: T2; Dynamic T1 SGE	65 patients: 3D T1 SGE (6) 3 patients: Dynamic T1 SGE (6)	No	Subtraction
1997	Nunes et al. (71)	Person	96	79	192	T1 spin-echo; T2 spin-echo	67 patients: 2D SPGR 125 patients: 3D SPGR	No	No

*All studies used machines with 1.5 Tesla MRI units except for Helbich's study where a 0.5 Tesla machine was used on three patients. All studies gave doses of gadolinium of 0.1 mg/kg body weight except for Boetes (0.2 mg/kg) and Obdeijn (20 mL for all patients).

†Level of analysis refers to the unit used for calculating sensitivity and specificity.

‡RODEO = rotating delivery of excitation off-resonance; MP-RAGE = magnetization-prepared rapid gradient echo; SGE = spoiled gradient echo; GRASS = gradient-recalled acquisition in the steady state; SPGR = spoiled gradient-recalled echo; STIR = short tau inversion recovery; 2D, 3D = 2 or 3 dimensional. Numbers in parentheses represent the numbers of times images were acquired.

REFERENCES

- (1) Miller AB, Baines CJ, To T, Wall C. Canadian National Breast Screening Study: 1. Breast cancer detection and death rates among women aged 40 to 49 years [published erratum appears in *Can Med Assoc J* 1993;148:718]. *CMAJ* 1992;147:1459-76.
- (2) Osteen RT, Cady B, Chmiel JS, Clive RE, Doggett RL, Friedman MA, et al. 1991 national survey of carcinoma of the breast by the Commission on Cancer. *J Am Coll Surg* 1994;178:213-9.
- (3) Winchester DP, Senen S, Immerman S, Blum M. A systematic approach to the evaluation and management of breast masses. *Cancer* 1983;51(12 Suppl):2535-9.
- (4) Yankaskas BC, Knelson MH, Abernathy ML, Cuttino JT Jr, Clark RL. Needle localization biopsy of occult lesions of the breast: experience in 199 cases. *Invest Radiol* 1988;23:729-33.
- (5) Cardena G, Eklund GW. Rate of compliance with recommendations for additional mammographic views and biopsies. *Radiology* 1991;181:359-61.
- (6) Goedde TA, Frykberg ER, Crump JM, Lay SF, Turetsky DB, Linden SS. The impact of mammography on breast biopsy. *Am Surg* 1992;58:661-6.
- (7) Layfield LJ, Chrischilles EA, Cohen MB, Bottles K. The palpable breast nodule. A cost-effectiveness analysis of alternate diagnostic approaches. *Cancer* 1993;72:1642-51.
- (8) Lindfors KK, Rosenquist CJ. Needle core biopsy guided with mammography: a study of cost-effectiveness. *Radiology* 1994;190:217-22.
- (9) Liberman L, Fahs MC, Dershaw DD, Bonaccio E, Abramson AF, Cohen MA, et al. Impact of stereotaxic core breast biopsy on cost of diagnosis. *Radiology* 1995;195:633-7.
- (10) Hillner BE, Bear HD, Fajardo LL. Estimating the cost-effectiveness of stereotaxic biopsy for nonpalpable breast abnormalities: a decision analysis model. *Acad Radiol* 1996;3:351-60.
- (11) Gram IT, Lund E, Slenker SE. Quality of life following a positive mammogram. *Br J Cancer* 1990;62:1018-22.
- (12) Parker RG. The "cost-effectiveness" of radiology and radiologists. *Radiology* 1993;189:363-9.
- (13) Frankel SD, Sickles EA. Morphologic criteria for interpreting abnormalities seen at breast MR imaging [editorial]. *Radiology* 1997;202:633-4.
- (14) Khalkhali I, Mena I, Diggles L. Review of imaging techniques for the diagnosis of breast cancer: a new role of prone scintimammography using technetium-99m sestamibi. *Eur J Nucl Med* 1994;21:357-62.
- (15) Heywang-Koebrunner SH. Diagnosis of breast cancer with MR—review after 1250 patient examinations. *Electromedica* 1993;61:43-52.
- (16) McNaughton Collins M, Ransohoff DF, Barry MJ. Early detection of prostate cancer. Serendipity strikes again. *JAMA* 1997;278:1516-9.
- (17) Sox HC, Blatt MA, Higgins MC, Marton KI. *Medical decision making*. Boston (MA): Butterworth-Heinemann; 1988.
- (18) Chalmers TC, Levin H, Sacks HS, Reitman D, Berrier J, Nagalingam R. Meta-analysis of clinical trials as a scientific discipline. I: Control of bias and comparison with large cooperative trials. *Stat Med* 1987;6:315-28.
- (19) Chalmers TC, Berrier J, Sacks HS, Levin H, Reitman D, Nagalingam R. Meta-analysis of clinical trials as a scientific discipline. II. Replicate variability and comparison of studies that agree and disagree. *Stat Med* 1987;6:733-44.
- (20) Sacks HS, Berrier J, Reitman D, Ancona-Berk VA, Chalmers TC. Meta-analyses of randomized controlled trials. *N Engl J Med* 1987;316:450-5.
- (21) L'Abbe KA, Detsky AS, O'Rourke K. Meta-analysis in clinical research. *Ann Intern Med* 1987;10:224-33.
- (22) Lau J, Ioannidis JP, Schmid CH. Quantitative synthesis in systematic reviews. *Ann Intern Med* 1997;127:820-6.
- (23) Olkin I. Statistical and theoretical considerations in meta-analysis. *J Clin Epidemiol* 1995;48:133-46.
- (24) Shapiro S, Venet W, Strax P, Venet L. Periodic screening for breast cancer: the Health Insurance Plan Project and its sequelae, 1963-1986. Baltimore (MD): The Johns Hopkins University Press; 1988.
- (25) Chamberlain J, Coleman D, Ellman R, Moss S, Thomas B, Price J, et al. Sensitivity and specificity of screening in the UK Trial of Early Detection of Breast Cancer. In: Miller AB, Chamberlain J, Daye NE, Hakama M, Prorok PC, editors. *Cancer screening*. Cambridge (U.K.): Cambridge University Press; 1991. p. 3-17.
- (26) Miller AB, Baines CJ, To T, Wall C. Canadian National Breast Screening Study: 2. Breast cancer detection and death rates among women aged 50 to 59 years [published erratum appears in *Can Med Assoc J* 1993;148:718]. *CMAJ* 1992;147:1477-88.
- (27) Fletcher SW, Black W, Harris R, Rimer BK, Shapiro S. Report of the International Workshop on Screening for Breast Cancer. *J Natl Cancer Inst* 1993;85:1644-56.
- (28) Kerlikowske K, Grady D, Barclay J, Sickles EA, Ernster V. Likelihood ratios for modern screening mammography: Risk of breast cancer based on age and mammographic interpretation. *JAMA* 1996;276:39-43.
- (29) Fryback DG. Bayes' theorem and conditional nonindependence of data in medical diagnosis. *Comput Biomed Res* 1978;11:423-34.
- (30) Chang P, Fryback DG. A simulation model of breast cancer natural history. *Med Decis Making* 1992;12:345.
- (31) Chang P, Fryback DG. Rethinking the benefits of breast cancer screening. *Med Decis Making* 1993;13:382.
- (32) Ries LA, Kosary CL, Hankey BF, Miller BA, Hurray A, Edwards BK, editors. *SEER Cancer Statistics Review, 1973-1994*. National Cancer Institute. NIH Publ No. 97-2789. Bethesda (MD); 1997.
- (33) U.S. Bureau of the Census. *Statistical abstract of the United States: 1996*, 116th edition. Washington (DC); 1996.
- (34) Colditz GA, Rosner BA, Speizer FE. Risk factors for breast cancer according to family history of breast cancer. For the Nurses' Health Study Research Group. *J Natl Cancer Inst* 1996;88:365-71.
- (35) Colditz GA, Willett WC, Hunter DJ, Stampfer MJ, Manson JE, Hennekens CH, et al. Family history, age, and risk of breast cancer. Prospective data from the Nurses' Health Study [published erratum appears in *JAMA* 1993;270:1548]. *JAMA* 1993;270:338-43.
- (36) Schwartz AG, King MC, Belle SH, Satariano WA, Swanson GM. Risk of breast cancer to relatives of young breast cancer patients. *J Natl Cancer Inst* 1985;75:665-8.
- (37) Slattery ML, Kerber RA. A comprehensive evaluation of family history and breast cancer risk. The Utah Population Database. *JAMA* 1993;270:1563-8.
- (38) Sattin RW, Rubin GL, Webster LA, Huzo CM, Wingo PA, Ory HW, et al. Family history and the risk of breast cancer. *JAMA* 1985;253:1908-13.
- (39) Parazzini F, La Vecchia C, Negri E, Franceschi S, Tozzi L. Family history of breast, ovarian and endometrial cancer and risk of breast cancer. *Int J Epidemiol* 1993;22:614-8.
- (40) Calle EE, Martin LM, Thun MJ, Miracle HL, Heath CW Jr. Family history, age, and risk of fatal breast cancer. *Am J Epidemiol* 1993;138:675-81.
- (41) Bain C, Speizer FE, Rosner B, Belanger C, Hennekens CH. Family history of breast cancer as a risk indicator for the disease. *Am J Epidemiol* 1980;111:301-8.
- (42) Dupont WD, Page DL. Breast cancer risk associated with proliferative disease, age at first birth, and a family history of breast cancer. *Am J Epidemiol* 1987;125:769-79.
- (43) Dupont WD, Page DL. Risk factors for breast cancer in women with proliferative breast disease. *N Engl J Med* 1985;312:146-51.
- (44) Carter CL, Corle DK, Micozzi MS, Schatzkin A, Taylor PR. A prospective study of the development of breast cancer in 16,692 women with benign breast disease. *Am J Epidemiol* 1988;128:467-77.
- (45) McDivitt RW, Stevens JA, Lee NC, Wingo PA, Rubin GL, Gersell D. Histologic types of benign breast disease and the risk for breast cancer. The Cancer and Steroid Hormone Study Group. *Cancer* 1992;69:1408-14.
- (46) Fleiss JL. *Statistical methods for rates and proportions*. New York (NY): John Wiley & Sons; 1981.
- (47) Rice JA. *Mathematical statistics and data analysis*. Pacific Grove (CA): Wadsworth & Brooks; 1988.
- (48) Littenberg B, Moses LE. Estimating diagnostic accuracy from multiple conflicting reports: a new meta-analytic method. *Med Decis Making* 1993;13:313-21.
- (49) Doubilet P, Begg CB, Weinstein MC, Braun P, McNeil BJ. Probabilistic sensitivity analysis using Monte Carlo simulation. A practical approach. *Med Decis Making* 1985;5:157-77.
- (50) Peer PG, Verbeek AL, Straatman H, Hendriks JH, Holland R. Age-specific sensitivities of mammographic screening for breast cancer. *Breast Cancer Res Treat* 1996;38:153-60.
- (51) Robertson CL. A private breast imaging practice: medical audit of 25,788 screening and 1077 diagnostic examinations. *Radiology* 1993;187:75-9.
- (52) Burhenne HJ, Burhenne LW, Goldberg F, Hislop TG, Worth AJ, Rebbeck PM, et al. Interval breast cancers in the Screening Mammography Program

- of British Columbia: analysis and classification. *AJR Am J Roentgenol* 1994;162:1067-71.
- (53) Tabar L, Fagerberg G, Chen HH, Duffy SW, Smart CR, Gad A, et al. Efficacy of breast cancer screening by age. New results from the Swedish two-country trial. *Cancer* 1995;75:2507-17.
- (54) D'Orsi CJ, Kopans DB. Mammographic feature analysis. *Semin Roentgenol* 1993;28:204-30.
- (55) Cross MJ, Harms SE, Cheek JH, Peters GN, Jones RC. New horizons in the diagnosis and treatment of breast cancer using magnetic resonance imaging. *Am J Surg* 1993;166:749-53.
- (56) Harms SE, Flamig DP, Hesley KL, Meiches MD, Jensen RA, Evans WP, et al. MR imaging of the breast with rotating delivery of excitation off resonance: clinical experience with pathologic correlation. *Radiology* 1993;187:493-501.
- (57) Perman WH, Heiberger EV, Herrmann VM. Half-Fourier, three-dimensional technique for dynamic contrast-enhanced MR imaging of both breasts and axillae: initial characterization of breast lesions. *Radiology* 1996;200:263-9.
- (58) Page DL, Dupont WD, Roger LW, Landenberger M. Intraductal carcinoma of the breast: follow-up after biopsy only. *Cancer* 1982;49:751-8.
- (59) The Steering Committee on Clinical Practice Guidelines for the Care and Treatment of Breast Cancer. The management of ductal carcinoma *in situ* (DCIS). *CMAJ* 1998;158 (Suppl 3):S27-34.
- (60) Welch HG, Black WC. Using autopsy series to estimate the disease "reservoir" for ductal carcinoma *in situ* of the breast: how much more breast cancer can we find? *Ann Intern Med* 1997;127:1023-8.
- (61) Easton DF, Ford D, Bishop DT, et al. Breast and ovarian cancer incidence in BRCA-1 mutation carriers. Breast Cancer Linkage Consortium. *Am J Hum Genet* 1995;56:265-71.
- (62) Wooster R, Bignell G, Lancaster J, Swift S, Seal S, Mangion J, et al. Identification of the breast cancer susceptibility gene BRCA2 [published erratum appears in *Nature* 1996;379:749]. *Nature* 1995;378:789-92.
- (63) Boetes C, Barentsz JO, Mus RD, van der Sluis RF, van Erning LJ, Hendriks JH, et al. MR characterization of suspicious breast lesions with a gadolinium-enhanced TurboFLASH subtraction technique. *Radiology* 1994;193:777-81.
- (64) Gilles R, Guinebretiere JM, Lucidarme O, Cluzel P, Janaud G, Finet JF, et al. Nonpalpable breast tumors: diagnosis with contrast-enhanced subtraction dynamic MR imaging [published erratum appears in *Radiology* 1994;193:285]. *Radiology* 1994;191:625-31.
- (65) Turkat TJ, Klein BD, Polan RL, Richman RH. Dynamic MR mammography: a technique for potentially reducing the biopsy rate for benign breast disease. *J Magn Reson Imaging* 1994;4:563-8.
- (66) Stomper PC, Herman S, Klippenstein DL, Winston JS, Edge SB, Arredondo MA, et al. Suspect breast lesions: findings at dynamic gadolinium-enhanced MR imaging correlated with mammographic and pathologic features. *Radiology* 1995;197:387-95.
- (67) Heiberger EV, Perman WH, Herrmann VM, Janney CG. Dynamic sequential 3D gadolinium-enhanced MRI of the whole breast. *Magn Reson Imaging* 1996;14:337-48.
- (68) Obdeijn IM, Kuijpers TJ, van Dijk P, Wiggers T, Oudkerk M. MR lesion detection in a breast cancer population. *J Magn Reson Imaging* 1996;6:849-54.
- (69) Bone B, Pentek Z, Perbeck L, Veress B. Diagnostic accuracy of mammography and contrast-enhanced MR imaging in 238 histologically verified breast lesions. *Acta Radiol* 1997;38(4 Pt 1):489-96.
- (70) Helbich TH, Becherer A, Trattning S, Leitha T, Kelkar P, Seifert M, et al. Differentiation of benign and malignant breast lesions: MR imaging versus Tc-99m sestamibi scintimammography. *Radiology* 1997;202:421-9.
- (71) Nunes LW, Schnall MD, Orel SG, Hochman MG, Langlotz CP, Reynolds CA, et al. Breast MR imaging: interpretation model. *Radiology* 1997;202:833-41.

NOTES

¹*Editor's note:* SEER is a set of geographically defined, population-based central tumor registries in the United States, operated by local nonprofit organizations under contract to the National Cancer Institute (NCI). Each registry annually submits its cases to the NCI on a computer tape. These computer tapes are then edited by the NCI and made available for analysis.

Supported by contract DAMD 17-96-C-6069, "Breast Cancer Support Contract," from the Department of the Army.

Manuscript received March 25, 1998; revised September 22, 1998; accepted September 25, 1998.

EDITORIALS

Serendipitous Breast Lesions on Magnetic Resonance Imaging: Why Is This Lesion Different From All Other Lesions?

Larry Kessler, R. James Brenner

Dr. Gamliel,¹ the local mammographer, refers a patient with a suspicious lesion that he doesn't think is cancer to the local magnetic resonance imaging (MRI) machine for a further test. The result confirms his suspicion: the lesion he had seen on mammography appears benign and there is no apparent worry. However, unexpected news arrived in the report: there is another lesion in the same breast that had not been detected by the initial mammogram. Dr. Gamliel is about to recommend surgical biopsy when his expert colleague says she has just read an article in the *Journal of the National Cancer Institute* about these lesions and the patient need not be sent for any invasive procedures. Astonished, Dr. Gamliel asks his colleague, "Why is this lesion different from all other lesions?" When his colleague has no satisfactory answer, he returns home to ponder the problem.

Dr. Gamliel sat down at dinner faced with the intriguing challenge of the question at hand and immediately recognized that he had four children who could help him formulate an answer. He gave them a copy of the paper by Lawrence et al. (1), published in this issue of the *Journal*, and decided to pose to each of them a single question that would, in part, address the initial question and help develop a more complete answer.

He asked his first-born son, the official at the country's most powerful regulatory agency: "What do the label and promotional claims of the MRI manufacturer say regarding incidental lesions?" (He did not like the label "serendipitous"—it just seemed to have the wrong connotation.)

The regulator addressed the problem thus: When the MRI machine came to us for review and approval, it not only promised a new era in diagnostic imaging but began to fulfill a niche in medical imaging not fully appreciated before the advent of the technology. However, MRI machines are approved only for general diagnostic use—no studies have been submitted to the Food and Drug Administration for any specific indication. Therefore, the manufacturer provides no guidance as to what to do with these findings or what they mean to the clinician. The industry looks to the clinical and public health community to provide research examining the risks and benefits of treating these lesions in order to refine their label, their equipment, and to aid in future development.

Next, Dr. Gamliel turned to his eldest daughter, the statistician, and asked, "Does this decision model give me enough information to confidently reject a recommendation for biopsy?"

The statistician responds: This study has numerous strengths, but some important weaknesses that must be acknowledged in order that we understand its implications. First, there are quite a few assumptions that underlie the composition of the model and its analysis. For example, the assumptions contained in the formula for post-test odds have a dramatic negative effect on the positive predictive value of MRI, and it is this low value that heavily influences the decision model. Other key assumptions include: the sensitivity and specificity of MRI for detection of breast cancer is the same for incidental as for index lesions and that diagnostic accuracy of clinical breast examination (CBE) and mammography is conditionally independent of MRI. The most important strength of this analysis lies in the direction it provides for future research and the identification of key parameters that must be measured in just such a study.

His other daughter is a skilled lawyer, and he poses the very difficult question, "What are my legal and ethical responsibilities in this particular case and in other similar cases?"

The lawyer ponders the problem and reminds her father of how Disraeli dismissed the usefulness of statistics. How can you not follow to completion the detection of an enhanced MRI lesion, however incidental it may be, she asks? It's one thing not to know something is there. But, once you have discovered clear evidence of some irregularity, once you tell the patient as you must ethically and legally, and once the possibility of cancer, even a remote one, has been raised with no other means of surveillance except biopsy or repeat MRI, you must take a serious look at that lesion. With no longitudinal studies to show the feasibility or benefit of "benign neglect," your statistics are not yet strong enough to defeat my claim of negligence based on the risk factors of my particular client. Unless my client is under a clinical protocol with the aim of following these apparently low-risk lesions

Affiliations of authors: L. Kessler, Office of Surveillance and Biometrics, Center for Devices and Radiological Health, Food and Drug Administration, Rockville, MD; R. J. Brenner, Tower Breast Imaging Center, University of California, Los Angeles.

Correspondence to: Larry Kessler, Sc.D., Office of Surveillance and Biometrics, Center for Devices and Radiological Health, Food and Drug Administration, 1350 Piccard Dr., Rockville, MD 20852.

See "Notes" following "References."

© Oxford University Press

and she is aware of the potential risks and benefits, the legal imperative here suggests that once you have made the referral to MRI you must deal with all the findings, positive or otherwise.

Finally, he turns to his youngest son, an exceptional clinician (a surgeon and radiologist) and asks, "Doesn't this lesion require the identical clinical attention that any other lesion found on MRI would dictate; do I have different clinical or ethical responsibilities in this particular case?"

The doctor appears conflicted about the situation, especially after hearing his siblings. He wants to entrust his patient's care to these statistics, after all he has a degree in public health, but it doesn't appear so simple, especially when he knows that delay in diagnosis of breast cancer is one of the most litigated claims in America. Look, he says, some of these "lesions" are dependent on menstrual cycles, so many represent benign proliferative disease. Yet, a few (admittedly a very few) are cancer, and if it's "my" cancer, it's my problem. The mammographic examination and CBE didn't show it the first time, just like some of those cancers metastatic to lymph nodes that are shown only on MRI. I'm not sure I can follow it with these more conventional tools the second time. Close follow-up, like my stock portfolio, may sound better than it really is. Therefore, the recommendation of the authors, that these lesions need not be subject to im-

mediate biopsy, while likely a reasonable scenario in the future, requires additional clinical study for validation.

Dr. Gamliel reclines in his chair, finishes his fourth cup of wine, and tries to summarize:

Thank you my children, your collective wisdom has persuaded me that we are at a starting point, not an end point. Truly, it is too early to decide the appropriate management of these incidental findings. The protocols have not been standardized, the information not much better than anecdotal, and no longitudinal studies of these lesions are available to establish a reasonable approach from a clinical perspective. Perhaps you will help me write a multicenter grant for the study of these incidental lesions, with a focus on a well-standardized protocol for longitudinal study. May we hope that future serendipity will not throw us such a difficult curve ball.

REFERENCE

- (1) Lawrence WF, Liang W, Mandelblatt JS, Gold KF, Freedman M, Ascher SM, et al. Serendipity in diagnostic imaging: magnetic resonance imaging of the breast. *J Natl Cancer Inst* 1998;90:1792-800.

NOTE

¹Dr. Gamliel is a fictitious character used to convey the editorial message.

Lest We Abandon Digital Rectal Examination as a Screening Test for Prostate Cancer

Joseph W. Basler, Ian M. Thompson

Until the mid-1980s, early detection for prostate cancer had only one tool—digital rectal examination (DRE). The tool is subjective with high interobserver variability (1,2), upward of 10% of prostates are considered abnormal, but only about 1%–2% of men examined are found to have disease. Even then, two thirds or more of the cancers discovered are found to be pathologically advanced (3). Perhaps more worrisome is the fact that, in one study, many men who ultimately died of prostate cancer had a normal DRE at the time of diagnosis (4).

Enter prostate-specific antigen (PSA) testing. There is no question that PSA testing has improved our ability to detect prostate cancer at an earlier clinical stage. PSA testing has 1) dramatically increased the number of tumors detected, 2) detected a population of tumors [stage T1c (5) that are by most measures clinically important, and 3) streamlined our metastatic evaluation of prostate cancer (e.g., identifying a class of patients for whom bone scans and even lymph node dissections may be unnecessary). By using PSA derivatives such as lower PSA thresholds for biopsy (e.g., 2.5 ng/mL for all men), age- and race-adjusted cutoffs, free/total PSA ratio (<25%), PSA/transition zone volume density, etc., the majority of prostate cancers can probably be detected serologically.

So what do we do with our clinical relic of times past? Do we discard DRE and perform our early diagnosis *en absentia*: merely ask the patient to have a blood test and never examine the patient? Reporting in this issue of the Journal, Schröder et al. (6) would have us believe so. They screened 10 523 men aged 54–76 years with three tests—DRE, measurement of PSA levels, and transrectal ultrasonography (TRUS). Using estimated disease prevalence, they determined the performance characteristics of DRE and PSA. Across the board, the performance of PSA was superior to DRE. However, we are not yet ready to dismiss DRE because of concerns with the study of Schröder et al. and a body of evidence supporting the value of DRE.

We have several criticisms of the methodology used by Schröder et al. (6) that directly affect the stated conclusions. 1)

Affiliations of authors: J. W. Basler, Division of Urology, University of Texas Health Sciences Center at San Antonio; I. M. Thompson, Division of Urology, University of Texas Health Sciences Center at San Antonio and Department of Surgery, Brooke Army Medical Center, Fort Sam Houston, TX.

Correspondence to: Ian M. Thompson, M.D., Division of Urology, University of Texas Health Sciences Center, 7703 Floyd Curl Dr., San Antonio, TX 78284-7845.

© Oxford University Press

**COST OF GENETIC COUNSELING AND TESTING FOR BRCA1 AND BRCA2
BREAST CANCER SUSCEPTIBILITY MUTATIONS**

William F. Lawrence, MD, MS¹, Beth N. Peshkin, MS², Wenchi Liang, PhD¹,

Claudine Isaacs, MD², Caryn Lerman, PhD², Jeanne S. Mandelblatt, MD, MPH¹

Cancer Clinical and Economic Outcomes Core, Division of Cancer Prevention and Control, and
Cancer Genetics, Lombardi Cancer Center, Georgetown University, Washington, D.C.

Correspondence and Requests for Reprints:

William F. Lawrence, M.D.

Cancer Clinical and Economic Outcomes Core

Lombardi Cancer Center

Georgetown University Medical Center

2233 Wisconsin Avenue, Suite 430

Washington, DC 20007

Phone: (202) 687-0817, Fax: (202) 687-0305, E-mail: lawrencw@gunet.georgetown.edu

Funded by: Contract DAMD 17-96-C-6069, "Breast Cancer Support Contract", from the
Department of the Army, and grant number 9 R01 HG01846-04 from the National Human
Genome Research Institute.

ABSTRACT

Purpose: Counseling and predictive testing are now available for the recently isolated BRCA1 and BRCA2 breast cancer susceptibility genes. We examined the societal costs of providing this counseling and testing to women at risk of having a breast cancer susceptibility mutation.

Methods: Genetic counselors in a research program prospectively monitored the time necessary to provide counseling and results disclosure. A time-motion study was used to determine time spent on phone calls, preparation, and documentation for counseling. Study participants were surveyed to determine travel time and need for dependent care during counseling. The test cost was calculated using the charge for full BRCA1/2 gene sequencing (Myriad Genetics, Inc.) divided by a charge-to-cost ratio of 1.4:1.

Results: Counselors spent an average of 4.2 hours providing genetic counseling for women at risk of having a susceptibility mutation. Genetic counseling without testing cost on average \$207, while counseling, testing, and disclosure of results totaled \$2051. Using physician-based counseling instead of genetic counselor-based counseling produced only small reductions in total costs; if a physician spent only 2% of the time that a counselor spends in providing counseling, the costs of counselign and testing would only be reduced by 9.1%.

Conclusions: While the cost of testing and counseling exceeded \$2000, the counseling portion of the cost comprised only 16% of the total cost. If testing becomes more common, costs would be expected to decrease due to economies of scale. The cost of detecting a mutation within a population of women is highly dependent on the prevalence of the mutation in the population.

Key Words: Cost analysis, Genetic counseling, BRCA1 susceptibility mutations, Hereditary breast cancer

INTRODUCTION

Recent advances in molecular genetics have lead to the isolation of the BRCA1 and BRCA2 breast cancer susceptibility genes [1,2]. Mutations in these genes may account for up to 10% of cases of breast cancer [3], and are observed in a significant proportion of families with multiple cases of breast and ovarian cancer [4]. Women who carry a BRCA1 or BRCA2 mutation have an estimated 55% to 85% lifetime risk of breast cancer, and a 15% to 60% risk of ovarian cancer [5-8]. Testing for mutations in these two genes is now available commercially.

Information obtained from genetic testing may enable women to make more informed decisions about their medical management. Women who test positive for a BRCA1 or BRCA2 mutation have several options for cancer screening and cancer risk reduction, although long-term studies demonstrating the efficacy of these strategies in mutation carriers are not yet available. Women could choose intensive surveillance, initiated at an early age, to maximize the chances of detecting a cancer early [9]. Based on recent clinical trial data, tamoxifen [10] or raloxifene [11] may be a consideration for breast cancer chemoprophylaxis, although data about the effects of these drugs in mutation carriers are not yet available. However, a recent study demonstrated that oral contraceptive use reduced the risk of ovarian cancer in women with a BRCA1 or BRCA2 mutation [12]. Women with a mutation may also opt to have a prophylactic mastectomy [13] and/or oophorectomy, to decrease the risk of breast and ovarian cancer, respectively. Several decision analyses [14,15] have suggested that a prophylactic mastectomy may prolong life approximately 3 to 4 years for a 30 year old woman with a BRCA1 susceptibility mutation.

BRCA1/2 genetic testing also has limitations and risks. Those testing positive may face

insurance or employment discrimination [16], and may encounter potentially high medical bills for cancer prophylaxis or surveillance due to their elevated risk of developing cancer. Women testing positive may also have higher levels of distress and anxiety than those testing negative [17]. Psychological distress may lead to avoidance of breast cancer screening [18,19], may interfere with comprehension of personal risk [20], and may impact on treatment or surveillance choices [21]. On the other hand, there may be psychological benefits to testing, especially for those persons in high risk families who test negative [22]. However, these individuals may feel falsely reassured that they will not get cancer [16] and therefore may be less likely to adhere to standard screening guidelines.

Counseling can assist women considering BRCA1/2 testing in making informed decisions about undergoing testing, as well as about possible surveillance and prophylactic options based upon the test result. Information about the probability of having a mutation, the risks and benefits of testing, and potential options if test results are positive is frequently provided by a genetic counselor or other appropriate clinician (such as oncology nurses, oncologists, or geneticists). Pre- and post-test genetic counseling, given its broad and complex nature, is time intensive. The amount of time and level of expertise necessary for adequate counseling, while necessary for informed decision making, would suggest that counseling is expensive; however, the cost of providing this counseling has not been well described. We examined the cost of providing genetic counseling for women at high risk for carrying a BRCA1/2 mutation within the settings of a research study. This study is part of an ongoing project evaluating the costs and outcomes of BRCA1/2 genetic counseling and testing.

Clinicians and women are interested in breast cancer genetic susceptibility testing [23-

25]. Clinicians have ordered BRCA1/2 testing outside of research settings [26], and some managed care organizations are covering part or all of the costs of these genetic tests [27]. As BRCA1/2 counseling and testing translates from research to clinical settings, it is important to better understand the costs involved in providing counseling and testing. In addition to examining the costs of testing and counseling within a research setting, we examine the potential impacts of direct physician counseling on the total costs.

METHODS

Study Population

Eligible subjects included women and men enrolled in a study prospective cohort study of BRCA1/2 testing. All study procedures were approved by the Georgetown University Institutional Review Board. Eligible participants had at least a 10% prior probability of carrying a mutation in either BRCA1 or BRCA2, consistent with published recommendations [28]. Participants were identified through both physician referrals and self referrals. After determining eligibility, participants completed a baseline telephone interview to collect data on family history, medical history, risk factors, and psychological well-being. After providing written informed consent, individuals participated in a pre-test counseling session (see below). Those opting for genetic testing provided a blood sample for mutation analyses, and results were disclosed during a subsequent genetic counseling session. Probands, the first individuals in a family to be offered testing, were women with a diagnosis of breast cancer (or in rare instances, men with a diagnosis of breast cancer) or ovarian cancer, often at a young age and in conjunction with a family history of these diseases. If a mutation was identified in the family, then male and

female relatives were invited to participate in the program. All genetic counseling and testing was offered free of charge to the participants. Follow-up interviews to assess the outcomes of testing are completed at 1, 6, and 12 months after testing (or declining test results). The present study focuses on testing collected at the pre-test interview and counseling visits.

Genetic Counseling Procedures and Content

The majority of participants completed genetic counseling visits with one of two board-eligible or board-certified masters-level genetic counselors; several were counseled by an oncology nurse with training in cancer genetics. Pre- and post-test genetic counseling was a required part of the study for those interested in testing. Individual disclosure sessions were performed with one of the genetic counselors, and in some cases, a medical oncologist. Regardless of the test result, the genetic counselor contacted the participant about two weeks after the result was given for an unstructured clinical follow-up telephone call.

The content of the genetic counseling sessions was standardized but not scripted for each participant. The following topics were addressed in the pre-test genetic counseling sessions: (1) a detailed review of the consultand's medical and family history, including compilation of a multi generation pedigree; (2) an overview of hereditary breast cancer and approach to risk assessment; (3) cancer risks associated with BRCA1 and BRCA2 mutations; (3) autosomal dominant inheritance and implications for relatives according to the pedigree; (4) options for medical management including surveillance and risk reduction; (5) the potential benefits, risks, and limitations of testing, including provisions for confidentiality; and (6) an exploration of the patient's anticipated response to test results and coping skills, plans for communication of test

results, and resources for support. The post-test session included a review of pertinent material from the first session, with a more tailored discussion of cancer risks, medical management options, risks to relatives, and coping strategies. Supportive counseling was provided as needed.

Measures

Data collected for the present analysis included time costs for counselors to provide counseling and costs for participants to receive counseling. The time necessary for a counselor to counsel a patient was derived from two sources. First, face-to-face counseling time was determined by prospectively recording the counseling time for a sample of 191 patients. Time data were recorded using a categorical scale (< 1 hour, 1-1.5 hours, > 1.5-2 hours, > 2-2.5 hours, > 2.5 hours). The midpoint of each category was used to estimate the time for each patient; the highest category was assumed to have a time of 2.5 hours. Second, counselors' telephone follow-up time and documentation time for counseling and phone calls were determined by monitoring the counselors' activities during a 3 week period. Activities tracked included the time required to provide in-person pre-test genetic counseling, disclosure of test results, telephone follow-up, in addition to the time spent preparing for the counseling session, and in documenting patient interactions, including genetic counseling summary notes for the chart and the patient. The program counseled both probands and relatives of probands who had known mutations. We based the counselor time costs on that of counseling probands; thus the cost of counseling that we calculate assumes no prior knowledge of mutations in the participant's family.

The time that participants spent traveling to the study site was determined by a written

survey administered to 186 women in the study. Time was recorded in categories of <10 minutes, 10-29 minutes, 30-59 minutes, 1-2 hours., >2 hours. Category midpoints were used as the estimated travel time. Participants were asked to specify a time if the highest category was chosen; this value was used if specified, and 2 hours was used if the value was not specified. The survey also asked participants whether they needed child or adult dependent care during the time that they were in counseling.

Data Analysis

To determine the resources necessary for providing genetic counseling and testing, we calculated the average national costs as opposed to the charges for providing these services. Costs considered in this analysis include: personnel costs, non-personnel related costs involved in providing counseling and testing, and patient costs of receiving counseling. We divided costs into two categories: those associated with genetic counseling, and the additional costs associated with genetic testing and disclosure of results. All costs are presented in 1998 dollars.

Personnel costs included the costs of the counselor's time and the time of clerical or receptionist staff. The time spent by the counselor in preparation, documentation, and telephone follow-up was estimated by determining the ratio of these times to time spent in face-to-face counseling, and then multiplying the face-to-face counseling time by these ratios. Cost of the counselor's time for one patient was determined by multiplying the total number of hours for face-to-face counseling, preparation, documentation, and phone calls spent by the counselor by the average hourly wage plus fringe benefit cost for genetic counselors, as determined by a national survey of genetic counselors [29,30]. This survey of 816 genetic counselors was

conducted in May, 1998. We estimated an hourly wage and fringe rate based upon average salary in the U.S., and assuming that the annual salary and fringe total was based upon 2,000 working hours per year.

The cost of clerical time was determined by estimate of the counselors, including time to assemble patient materials, type appointment letters, and review materials returned by patients for completeness. This time was multiplied by an average hourly cost based upon the median weekly earnings for clerical personnel [31]. Counselors' office space necessary for counseling was calculated using the cost to the institution of the counselors' office space, pro-rated for the time spent providing counseling services to one consultand.

We considered two main costs for the patient in receiving counseling: the costs of the time in counseling, including the travel time to reach the counselor's office, and the costs of providing short-term dependent care (if any) while the patient was at counseling. Time costs were determined using the average sex and age-specific hourly wage rates provided by the Bureau of Labor Statistics [32] for an employed woman of the average age of the cohort multiplied by the average counseling and travel times for the participants. Dependent care costs were estimated for those women reporting needing this care by taking the time necessary to receive counseling multiplied by an estimate of \$8 per hour.

Costs of testing and disclosure were calculated as follows. Personnel costs to provide testing and disclosure include the cost of the genetic counselor's time to disclose the results to the woman and the cost of a phlebotomist's time to draw blood for genetic testing. While a medical oncologist had previously been present with the counselor for disclosure of results to those who tested positive for a mutation, the program's current practice is to have the counselor

alone provide disclosure; thus, personnel costs included the counselor's time but not an oncologist's time. Phlebotomists were asked to estimate the time necessary to draw blood for genetic testing; this time was multiplied by the average salary plus fringe benefit cost for a phlebotomist at our institution. Participant costs were calculated in a similar fashion to those for the genetic counseling.

Non-personnel costs of testing included cost to the institution of phlebotomy materials and the cost of the test itself. The cost of testing is based upon the cost of providing full gene sequencing for BRCA1 and BRCA2; the cost of this test is estimated using the retail charge for commercially available full gene sequencing (Myriad Genetics, Inc., Salt Lake City, Utah) using an estimated government charge-to-cost ratio of 1.4:1.

We performed two sensitivity analyses to examine changes in our assumptions about the costs involved in counseling and testing. First, since the cost of testing is estimated from a retail charge, we examined the effects of varying the charge-to-cost ratio used to calculate the cost. Second, to examine the effects of physician counseling instead of genetic counselor-based counseling, we used an estimated physician salary of \$150,000 per year, plus a 23% fringe benefit rate, to calculate a representative hourly time cost for physician counseling. The cost of physician-based counseling and testing was then calculated as a function of the time spent by physicians compared to genetic counselors.

To examine the costs of screening in different populations, we estimated the cost of counseling and testing that would be necessary on average to find one BRCA1 or BRCA2 mutation in these populations. To perform this analysis, we first calculated the number needed to test to find a mutation, defined as the inverse of the prevalence of the mutations in the population

of interest. We assumed that counseling and testing would consist of full pre-test counseling as represented by the proband counseling in CARE, and that full gene sequencing followed by post-test counseling. Thus, the cost of finding a mutation is calculated by:

$$Cost = \frac{[Cost_{Counseling} + Cost_{Disclosure, Testing}]}{prevalence}.$$

RESULTS

Cohort Characteristics

Participants in the program had an average age of 47.3 years (s.d. 12.2). Of the 181 participants for whom data on time of counseling are available, 127 (70.2%) were affected either by breast or by ovarian cancer. One hundred twenty three participants (68.0%) were probands, and 58 were relatives of probands with known mutations. There were 161 women and 20 men in the study; only 3 of the males were probands. Genetic test results were available for 159 of these participants; 38 (23.9%) tested positive for a known deleterious BRCA1 or BRCA2 mutation.

Counseling Costs

Figure 1 shows the distribution of counseling times for the cohort by cancer status. On average, the counselors spent 1.64 hours (s.d. 0.40) of time in face-to-face counseling for each proband in the study, significantly longer than the average 1.33 hours (s.d. 0.43) spent counseling relatives ($p < 0.0001$ by two-tailed t-test). For this time spent with a proband, the counselors spent

approximately 0.47 hours in phone conversations with the participant, and another 2.15 hours preparing for and documenting the counseling, for a total time of 4.3 hours spent by the counselor in order to provide counseling for 1 participant. Costs of counselor time were calculated using a national average of salary plus fringe benefits of \$53,755 per year, or an average hourly rate of \$26.88 per hour. Using this rate, we calculate a total cost of counselors' time of \$114 per proband (Table 1).

The costs of clerical time and participant time are shown in table 2. These costs are based upon an estimate of 30 minutes of clerical time necessary for each proband counseled, and of an average of 5.51 time spent by participants undergoing counseling. An average of 14% of participants need a care-giver for a child or dependent adult during the counseling session. Non-personnel costs for counseling include the office space for the counseling session.

Testing Costs

The additional costs associated with receiving testing in addition to counseling are also listed in Table 1. Costs include the costs of the phlebotomist's time, estimated by our phlebotomists at 30 minutes average per person. This estimate encompassed time to complete test requisition forms and delivery of samples. For patients who opted to obtain their test results, an additional 0.60 hours (s.d. 0.29) of face-to-face counseling, on average, was required to disclose the result to the participant. The major cost of testing is the gene sequencing itself.

Sensitivity Analyses

Charge-to-Cost Ratio

Our baseline analysis assumes the charge of \$2400 and a charge-to-cost ratio of 1.4:1. If the charge-to-cost ratio is larger, representing a greater difference between the charge for the test and the cost of the test, then the cost of the test will be lower. If the charge-to-cost ratio is 2:1, then the cost of the test will be \$1200, and the total cost of counseling and testing will be \$1537, with the cost of the test comprising 78% of the total cost.

Physician Counseling

Our analysis examines the cost of having genetic counselors provide counseling and disclosure of results. What would happen to the cost of counseling and testing if physicians provided this counseling and disclosure instead of counselors? Table 2 shows the impact on costs of physicians providing counseling, as a function of the total time spent to provide counseling (including preparation, counseling, documentation, and follow-up phone calls), expressed as a percentage of the time spent by the genetic counselors in this study. Physician counseling, even if much shorter than counseling by a genetic counselor, does not have a large impact on total cost; even if the total physician time is 5 minutes, the total cost of testing and counseling are reduced only 9.1% below the baseline cost.

Cost of Finding a Mutation

Table 3 shows the average cost of counseling and testing needed to be performed to detect one susceptibility mutation in various populations; we assume for this analysis that the people tested do not have relatives with known mutations, so the cost is based upon counseling

and full gene sequencing. In our research setting of counseling high risk participants, the prevalence of a deleterious BRCA1 or BRCA2 mutation is 26%; therefore, on average, 4 participants need to be tested to find one mutation. At the other extreme, given the low prevalence of the mutation in otherwise unselected women in the general US population, 714 women would need to be tested on average to find a single mutation. Using our estimate of the cost of counseling and testing, the average cost of finding a mutation would be about \$8,600 for the high-prevalence CARE sample, but testing unselected women in the US population would cost approximately \$1.5 million to detect a mutation (Table 3).

DISCUSSION

There are potential benefits to testing individuals at high-risk for carrying a BRCA1 or BRCA2 mutation. However, there are also substantial costs associated with this testing, exceeding \$2000 for the combination of genetic counseling and testing. The major expense for this combination is the genetic test itself, for which we used the estimated cost of full gene sequencing. Currently, there are over 400 known or suspected deleterious mutations identified for the BRCA1 and BRCA2 genes [33]. Many families harbor "private" mutations that have never been reported before, but which are known to be deleterious. Full gene sequencing is considered to be the most sensitive method of detecting these mutations [34]. However, in certain populations, a few "founder" mutations appear to account for the majority of detectable alterations in BRCA1 and/or BRCA2. For example, common founder mutations have been reported in individuals of Ashkenazi Jewish [8], Icelandic [35], or French Canadian [36] descent.

Less expensive tests to detect these mutations are available. In addition, in most instances, relatives of an individual with a documented mutation can be tested only for the mutation found in their family. Judicious use of such tests may reduce the overall cost of testing. For instance, in Ashkenazi Jews, a less expensive panel to detect common founder mutations, followed by full gene sequencing if the test panel does not detect a mutation, may be a less costly method of detecting mutations. Also, if testing became more common, economies of scale may reduce the cost of full gene sequencing, eg. by allowing the tests to be run in larger batches decreasing the labor cost for each test in the batch.

The genetic counseling session represented only 10% of the total cost of counseling and testing. While counseling is a time-intensive procedure, requiring a total of 4.3 hours of the counselor's time, the cost of providing this counseling is small in relation to the cost of the test. Genetic counseling should be considered as part of the informed consent process, and helps to ensure that individuals make knowledgeable choices about testing. This process maximizes the likelihood that individuals will derive some benefits from testing, while minimizing the chances of adverse or unanticipated effects. Moreover, the potential to misinterpret test results exists [37] and could have substantial implications for patients and families. Women may prefer obtaining pretest counseling with a genetic counselor over either an oncologist or primary care physician, particularly if they desire to discuss psychosocial issues [38]. Therefore, we strongly advocate that genetic testing be performed only in conjunction with genetic counseling, consistent with other published recommendations [28,39]. In addition, given the time intensive and complex nature of such counseling, it is unlikely that offering such services will be feasible for most physicians. Thus, a referral to a genetic counselor or other specialized provider will be

necessary. Since the cost of the test is the largest part of the total cost of counseling and testing, representing 83% of the total, physician counseling would not result in a large reduction in costs even if much less time was spent by the physicians than by the counselors.

The average cost of finding a mutation in the population depends on the prevalence of the mutations in the populations. The values in Table 3 represent a large range of costs for finding a mutation; this large range is a consequence of the prevalence in the denominator of the equation to determine the average cost to find a mutation. As the prevalence approaches 0, the cost of finding a single mutation approaches infinity. While this study only examines costs, not effectiveness, it is unlikely that unselected counseling and testing of women in the general population will be cost-effective, since the cost of finding a mutation is so high that it is very unlikely that the benefit produced will justify the cost of counseling and testing.

Several caveats should be considered when evaluating our results. First, the costs calculated in this study are the costs associated with a research program, and not those of standard clinical practice. BRCA1 and BRCA2 gene testing is still generally considered a research tool, although the tests are now commercially available for use in clinical practice. As providing testing is a major portion of the costs, we do not expect the overall costs of counseling plus testing to change significantly in clinical practice unless the type of test used were to change. We are interested in costs in this study, not charges, to reflect the amount of resources (as measured by health care dollars) to provide counseling and testing. Our value used for the cost of full gene sequencing is an estimate based upon the model of using commercial testing. The cost of producing a product in private industry is generally not a matter of public record, so we are unable to provide an exact accounting of this cost. To estimate, we use an approximate

governmental charge-to-cost ratio. The estimate is similar to an accounted cost of full gene sequencing of the COL2A1 gene [40].

Second, our study evaluated counseling at only one location; content and delivery of counseling may differ at other locations, resulting in differing costs. While the content of genetic counseling for hereditary breast cancer is likely to have similar components in a clinical setting (Schneider), the risk level of the patient, sociodemographic factors such as education level, and protocols of individual centers may vary. For example, some centers have designed their clinics such that patients are seen by a multi disciplinary team including medical oncologists, genetic counselors, nurses, and psychologists [41-43]. In some cases, group sessions may be conducted for pretest education [22]; however, disclosure of test results should take place on an individual basis. Finally, while we considered the costs of the counseling and testing, the benefits are not fully described. Decision models would suggest that in those with a BRCA1/2 mutation prophylactic surgery may be beneficial [14,15,44], and that testing some high-risk women will improve their outcomes if they make decisions about prophylactic surgery based upon their test result [44].

In conclusion, genetic counseling and testing are associated with significant costs. If testing is considered, detailed accounting of the risks and benefits should be provided to the consultand; this counseling can be performed for a fraction of the cost of the test itself. Whether the costs of counseling and testing of women at risk for a mutation is justified by the benefits of these interventions has yet to be determined, and will be the subject of future work.

Acknowledgments:

We gratefully acknowledge the contributions of Tiffani DeMarco, MS and Barbara Brogan, RN, MS, for their work with patients in the CARE program, and to David Main, MS, and Carol Kavanagh, MA for statistical and programming assistance. We would also like to thank the participants of the CARE program.

REFERENCES

1. Miki Y, Swensen J, Shattuck-Eidens D, Futreal PA, Harshman K, Tavtigian S, et al. A strong candidate for the breast and ovarian cancer susceptibility gene BRCA1. *Science* 1994;266:66-71.
2. Wooster R, Bignell G, Lancaster J, Swift S, Seal S, Mangion J, et al. Identification of the breast cancer susceptibility gene BRCA2. *Nature* 1995; 378:789-92.
3. Claus EB, Schildkraut JM, Thompson WD, Risch NJ. The genetic attributable risk of breast and ovarian cancer. *Cancer* 1996; 77: 2318-24.
4. Frank TS, Manley SA, Olopade OI, Cummings S, Garber JE, Bernhardt B, et al. Sequence analysis of BRCA1 and BRCA2: correlation of mutations with family history and ovarian cancer risk. *J Clin Oncol* 1998; 16: 2417-25.
5. Easton DF, Ford D, Bishop T, and the Breast Cancer Linkage Consortium. Breast and ovarian cancer incidence in BRCA1-mutation carriers. *Am J Hum Genet* 1995; 56:265-71.
6. Ford D, Easton DF, Stratton M, Narod S, Goldgar D, Devilee P, Bishop DT, et al. Genetic heterogeneity and penetrance analysis of the BRCA1 and BRCA2 genes in breast cancer families. *Am J Hum Genet* 1998; 62:676-89.

7. Ford D, Easton DF, Bishop DT, Narod SA, Goldgar DE, and the Breast Cancer Linkage Consortium. Risks of cancer in BRCA1-mutation carriers. *Lancet* 1994; 343:692-5.
8. Struwing JP, Hartge P, Wacholder S, Baker SM, Berlin M, McAdams M, et al. The risk of cancer associated with specific mutations of BRCA1 and BRCA2 among Ashkenazi Jews. *N Eng J Med* 1997; 336:1401-8.
9. Burke W, Daly M, Garber J, Botkin J, Kahn MJE, Lynch P, et al. Recommendations for follow-up care of individuals with an inherited predisposition to cancer: II. BRCA1 and BRCA2. *JAMA* 1997; 277:997-1003.
10. Fisher B, Costantino JP, Wickerham DL, Redmond CK, Kavanah M, Cronin WM, et al. Tamoxifen for prevention of breast cancer: report of the National Surgical Adjuvant Breast and Bowel Project P-1 study. *J Natl Cancer Inst* 1998;90:1371-88.
11. Cummings SR, Norton L, Eckert S, Grady D, Cauley J, Knickerbocker R, et al. Raloxifene reduces the risk of breast cancer and may decrease the risk of endometrial cancer in postmenopausal women. Two year findings from the multiple outcomes of raloxifene evaluation (MORE) trial. *Proc Am Soc Clin Oncol* 1998; 17: 3 (abstract).
12. Narod SA, Risch H, Moslehi R, DørumA, Neuhausen S, Olsson H, et al. Oral contraceptives and the risk of hereditary ovarian cancer. *N Engl J Med* 1998;339:424-8.

13. Hartmann LC, Schaid DJ, Woods JE, et al. Efficacy of bilateral prophylactic mastectomy in women with a family history of breast cancer. *N Engl J Med.* 1999;340:77-84.
14. Schrag D, Kuntz KM, Garber JE, Weeks JC. Decision analysis— effects of prophylactic mastectomy and oophorectomy on life expectancy among women with BRCA1 or BRCA2 mutations. *N Engl J Med* 1997;336:1465-71.
15. Grann VR, Panageas KS, Whang W, Antman KH, Neugut AI. Decision analysis of prophylactic mastectomy and oophorectomy in BRCA1-positive or BRCA2-positive patients. *J Clin Oncol* 1998; 979-85.
16. Geller G, Botkin J, Green M, Press, N, et al. Genetic testing for susceptibility to adult-onset cancer: The process and content of informed consent. *JAMA* 1997;277:1467-1474.
17. Croyle RT, Smith KR, Botkin JR, Baty B, Nash J. Psychological responses to BRCA1 mutation testing: preliminary findings. *Health Psychology* 1997;16(1):63-72.
18. Kash KM, Holland JC, Halper MS, Miller DG. Psychological distress and surveillance behaviors in women with a family history of breast cancer. *J Natl Cancer Inst* 1992;84:24-30.
19. Lerman C, Daly M, Sands C, et al. Mammography adherence and psychological distress among women at risk for breast cancer. *J Natl Cancer Inst* 1993;85:1074-80.

20. Lerman C, Lustbader E, Rimer B, et al. Effects of individualized breast cancer risk counseling: A randomized trial. *J Natl Cancer Inst* 1995;87(4):286-292.

21. Stefanek ME. Bilateral prophylactic mastectomy: issues and concerns. *J Natl Cancer Inst Mono* 1995;17:37-42

22. Lerman C, Narod S, Schulman K, Hughes C, Gomez-Caminero A, Bonney G, et al. BRCA1 testing in families with hereditary breast-ovarian cancer: a prospective study of patient decision making and outcomes. *JAMA* 1996; 275:1885-92.

23. Tambor ES, Rimer BK, Strigo TS. Genetic testing for breast cancer susceptibility: Awareness and interest among women in the general population. *Amer J Med Gene* 1997;68:43-49.

24. Chaliki H, Loader S, Levenkron JC, Logan-Young W, Hall WJ, Rowley PT. Women's receptivity to testing for a genetic susceptibility to breast cancer. *Am J Public Health* 1995;85:1133-1135.

25. O'Malley MS, Klabunde CN, McKinley ED, Newman B. Should we test women for inherited susceptibility to breast cancer? What do NC primary care physicians think. *N C Med J* 1997;58(3):176-180.

26. Cho MF, Sankar P, Wolpe PR, Godmilow L. Commercialization of BRCA1/2 testing: practitioner awareness and use of a new genetic test. *Am J Med Genet* 1999; 83:157-163.
27. Atlantic Information Services. Weighing gene-based tests, therapies. *Managed Care Week*, November 23, 1998.
28. Statement of the American Society of Clinical Oncology: genetic testing for cancer susceptibility. *J Clin Oncol* 1996;14:1730-6.
29. Schneider KA, Kalkbrenner KJ. Professional Status Survey 1998. *Perspectives in Genetic Counseling* 1998;20:S1-S8.
30. Doyle DL. The 1996 Professional Status Survey. *Perspectives in Genetic Counseling*. 1996;18:1-8.
31. US Bureau of the Census. *Statistical Abstract of the United States:1998* (118th edition). Washington, DC, 1998.
32. Bureau of Labor Statistics. <http://stats.bls.gov/blshome.html>
33. Breast Cancer Information Core Database.
http://www.nhgri.nih.gov/Intramural_research/Lab_transfer/Bic

34. Shattuck-Eidens D, Oliphant A, McClure M, McBride C, Gupte J, Rubano T, et al. BRCA1 sequence analysis in women at high risk for susceptibility mutations: risk factor analysis and implications for genetic testing. *JAMA* 1997; 278: 1242-50.
35. Thorlacius S, Sigurdsson S, Bjarnadottir H, Olafsdottir G, Jonasson JG, Tryggvadottir L, et al. Study of a single BRCA2 mutation with high carrier frequency in a small population. *Am J Hum Genet* 1997; 60: 1079-84.
36. Tonin PN, Mes-masson A-M, Futreal PA, Morgan K, Mahon M, Foulkes WE, et al. Founder BRCA1 and BRCA2 mutations in French Canadian breast and ovarian cancer families. *Am J Hum Genet* 198; 63: 1341-51.
37. Giardello FM, Brensinger JD, Petersen GM, Luce MC, Hylind LM, Bacon JA, et al. The use and interpretation of commercial APC gene testing for familial adenomatous polyposis. *N Engl J Med* 1997; 336: 823-7.
38. Audrain J, Rimer B, Cella D, Garber J, Peshkin BN, Ellis J, et al. Genetic counseling and testing for breast-ovarian cancer susceptibility: what do women want. *J Clin Oncol* 1998;16:133-8.
39. McKinnon WC, Baty BJ, Bennett RL, Magee M, Neufeld-Kaiser WA, Peters KF, et al.

Predisposition genetic testing for late-onset disorders in adults: a position paper of the National Society of Genetic Counselors. *JAMA* 1997; 278: 1217-20.

40. Ganguly and Williams, 1997

41. McKinnon WC, Guttmacher AE, Greenblatt MS, Compas BE, May S, Cutler RE, et al. The familial cancer program of the Vermont Cancer Center: development of a cancer genetics program in a rural area. *Journal of Genetic Counseling* 1997; 6: 131-45.

42. Lemon SJ, Tinley ST, Fusaro RM, Lynch HT. Cancer risk assessment in a hereditary cancer prevention clinic and its first year's experience. *Cancer* 1997; 80: 606-13.

43. Schneider KA, Marnane D. Cancer risk counseling: how is it different? *Journal of Genetic Counseling* 1997; 6: 97-109.

44. Tengs TO, Winer EP, Paddock S, Aguilar-Chavez O, Berry DA. Testing for BRCA1 and BRCA2 breast-ovarian cancer susceptibility genes: a decision analysis. *Med Decis Making* 1998;18:365-75.

45. Malone KE, Daling JR, Thompson JD, O'Brien CA, Francisco LV, Ostrander EA. BRCA1 mutations and breast cancer in the general population: analyses in women before age 35 years and in women before age 45 years with first-degree family history. *JAMA* 1998;279:922-9.

46. Newman B, Mu H, Butler LM, Milikan RC, Moorman PG, King MC. Frequency of breast cancer attributable to BRCA1 in a population-based series of American women. *JAMA* 1998;279:915-21.

47. Whittemore AS, Gong G, Itnyre J. Prevalence and contribution of BRCA1 mutations in breast and ovarian cancer: results from three US population-based case control studies of ovarian cancer. *Am J Hum Genet* 1997;60:496-504.

Table 1. Costs of Genetic Counseling and Testing

Category	Cost
<i>Counseling Costs</i>	
Counselor costs	\$114
Ancillary personnel costs	\$7
Participant costs	\$80
Non-personnel costs	<u>\$7</u>
Total Counseling Costs	\$208
<i>Testing and Results Disclosure Costs</i>	
Counselor disclosure costs	\$42
Participant costs	\$72
Phlebotomist cost	\$7
Phlebotomy material, office space	\$8
Gene Sequencing	<u>\$1714</u>
Total Testing and Disclosure Costs	\$1843
Total Counseling + Testing Costs	\$2051

Table 2. Cost for Physician-Based Counseling and Testing

Total Time	% Time of Counselor	Cost	% Reduction of Cost*
1.06 hr.	25%	\$1997	2.6%
25 min.	10%	\$1948	6.9%
15 min	6%	\$1887	8.0%
5 min.	2%	\$1864	9.1%

* Reduction in cost compared to baseline analysis.

Table 3. Cost of Detecting a BRCA1 or BRCA2 Mutation*

Population	Mutation Prevalence	Reference	Cost to Detect Mutation
CARE	25.6%		\$8,582
Breast Cancer 21-44 y.o.	7.2%	[45]	\$28,489
Breast Cancer, unselected	2.6%	[46]	\$78,892
U.S. Population	0.14%	[47]	\$1,464,137

* Average cost of testing and counseling for women in the population of interest necessary on average to have one positive test for a BRCA1 or a BRCA2 mutation, assuming the use of full gene sequencing, and that the test is the gold standard diagnosis of a mutation.

Figure 1. Distribution of time taken to provide face-to-face genetic counseling to women at risk for carrying a BRCA1/2 breast cancer susceptibility mutation.

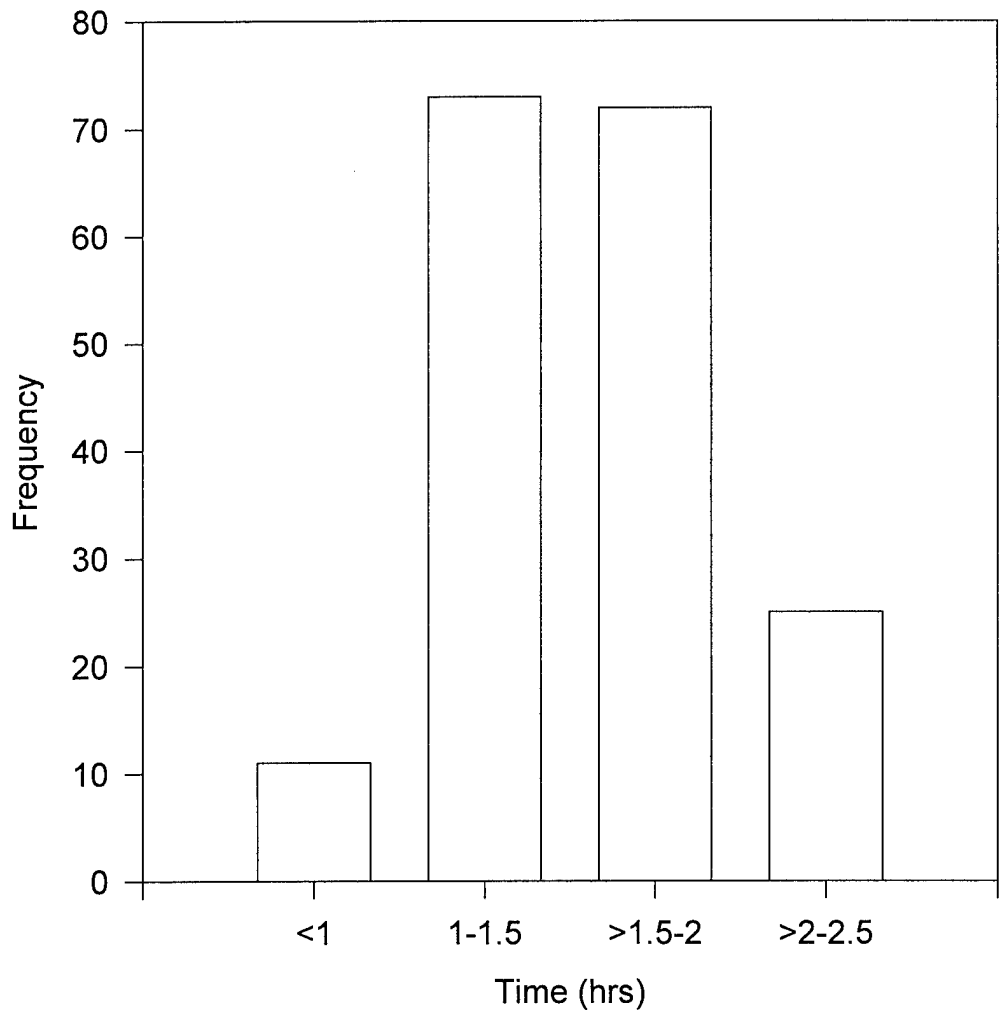

Does over-the-counter nicotine replacement therapy improve smokers' life expectancy?

William F Lawrence, Stevens S Smith, Timothy B Baker, Michael C Fiore

Abstract

Objective—To determine the public health benefits of making nicotine replacement therapy available without prescription, in terms of number of quitters and life expectancy.

Design—A decision-analytic model was developed to compare the policy of over-the-counter (OTC) availability of nicotine replacement therapy with that of prescription (R) availability for the adult smoking population in the United States.

Main outcome measures—Long-term (six-month) quit rates, life expectancy, and smoking attributable mortality (SAM) rates.

Results—OTC availability of nicotine replacement therapy would result in 91 151 additional successful quitters over a six-month period, and a cumulative total of approximately 1.7 million additional quitters over 25 years. All-cause SAM would decrease by 348 deaths per year and 2940 deaths per year at six months and five years, respectively. Relative to R nicotine replacement therapy availability, OTC availability would result in an average gain in life expectancy across the entire adult smoking population of 0.196 years per smoker. In sensitivity analyses, the benefits of OTC availability were evident across a wide range of changes in baseline parameters.

Conclusions—Compared with R availability of nicotine replacement therapy, OTC availability would result in more successful quitters, fewer smoking-attributable deaths, and increased life expectancy for current smokers.

(*Tobacco Control* 1998;7:364-368)

Keywords: smoking cessation, nicotine replacement therapy, over-the-counter sales, decision analysis

Introduction

Smoking cessation and prevention strategies hold tremendous potential to improve public health.¹ Smoking-attributable mortality is now estimated at more than 400 000 deaths per year and the health benefits of quitting at any age have been well documented.² Although over 70% of smokers would like to quit smoking,³ less than 5% of self-quitters successfully stop smoking for six months or more,⁴ a figure considerably lower than the 10-30% quit rates produced by smoking cessation programmes using prescription (R) nicotine replacement products (transdermal patches or

polacrilex gum).⁵⁻⁷ Although smoking cessation programmes are more efficacious than self-quitting, considerable evidence suggests that most smokers are reluctant to participate in cessation programmes.⁸⁻¹⁰ This suggests that making nicotine replacement products available outside formal cessation programmes may increase smoking cessation rates among American smokers. One strategy to make nicotine replacement products more available to self-quitters is to make them available over the counter (OTC).^{11 12}

In July 1996, the FDA first approved over-the-counter sales of one brand of nicotine patch.¹³ The patches appear to be a popular cessation aid; by the end of 1996, one brand of OTC nicotine patch, Nicoderm CQ, had sold over 3.2 million units (unpublished data, SmithKline Beecham, Inc.). Use of nicotine replacement therapy has been estimated to increase by over 150% since nicotine patches and nicotine gum have become available without prescription.¹⁴ An accurate estimate of the potential public health benefits of the policy of making nicotine replacement available without prescription depends upon formal analysis that models the anticipated benefit based upon specific, empirically derived assumptions. The current study used decision-analytic techniques to compare the public health impact of prescription with over-the-counter nicotine replacement therapy availability. The analyses used data on the estimated percentage of American smokers who would quit successfully per year, and on estimated reductions in smoking-attributable mortality, derived from sources available before nicotine replacement was available OTC in the United States, or from post-marketing surveillance after nicotine replacement was available without prescription.

Methods

We constructed a simulation model¹⁵ using a computer spreadsheet (Microsoft Excel for Windows version 5.0, Microsoft Corporation, Redmond, Washington) to compare the public health impact of making nicotine replacement therapy (NRT) by transdermal patch or by nicotine polacrilex gum available over the counter (OTC scenario) with the practice of prescription-only availability (R scenario). We used data from non-prescription availability Nicoderm patch studies conducted by Alza Corporation as proxy for over-the-counter nicotine replacement in general, due to the availability of over-the-counter data for this particular product. Outcomes determined for

Cancer Clinical and Economic Outcomes Core, Lombardi Cancer Center, Georgetown University Medical Center, Washington, DC, USA
W F Lawrence

Center for Tobacco Research and Intervention, University of Wisconsin Medical School, Madison, Wisconsin
S S Smith
T B Baker
M C Fiore

Correspondence to:
Dr WF Lawrence, Cancer Clinical and Economic Outcomes Core, Lombardi Cancer Center, 2233 Wisconsin Avenue, Suite 430, Washington, DC 20007, USA;
lawrencw@gunet.georgetown.edu

Table 1 Model parameters

Parameter	Value*	Sources
OTC scenario		
Probability of using NRT if attempting to quit	0.35	8, 14
Probability of quitting six months using NRT†	0.106	19
Rx Scenario		
Probability of using NRT if attempting to quit	0.14	8‡
Probability of quitting six months using NRT†	0.106	19
Both scenarios		
Probability of attempting to quit by any method	0.31	17§
Probability of quitting six months for those attempting without NRT†	0.049	4, 24
Markov models		
One-year probability of relapse for quitters in first two years	0.11	2¶
One-year probability of relapse for long-term quitters	0.024	2¶
Relative risk of death, current smoker to former smoker (age 18-29 years)	1.0	**
Relative risk of death for current smoker to former smoker (age ≥30 years)	Age and sex dependent (range: 1.2-2.5)	1, 17, 23††
One-year probability of death, former smoker	Age and sex dependent (range: 0.0051-0.18)	16

OTC = over the counter; NRT = nicotine replacement therapy.

*Values for table 1 are presented as the weighted average of values across age and sex strata.

†Based on self-reported continuous quit rates in OTC setting; see text.

‡Based on all reported NRT use (patch and gum) from Pierce *et al.* [8]

§Based on the 1992 National Health Interview Survey data from the National Center for Health Statistics on CD-ROM. These estimates were computed by Dr SS Smith, who is solely responsible for the accuracy and appropriateness of the calculations.

¶Estimates were based on two stage DEALE transformations [14] to estimate yearly relapse transition probabilities for short-term (1-2 year) and long-term quitters based on National Health and Nutrition Examination Survey data.

**No data were available for this age group, so we used a conservative assumption that the mortality was not increased in current smokers relative to former for those less than 30 years old.

††Estimates were derived from the Cancer Prevention Study II (CPS-II), using the above sources, as well as unpublished CPS-II data provided by MJ Thun (personal communication). Data are stratified by age and sex, but are independent of duration of abstinence for former smokers.

both the OTC and Rx scenarios included: (a) the total number of smokers who quit at six months; (b) overall smoking-attributable mortality; and (c) life expectancy of an average smoker using state-transition (Markov) modelling.

DATA SOURCES

Modelling required estimates derived from diverse sources. A MEDLINE literature search was conducted for relevant literature on model parameters. Whenever possible, effectiveness data was preferentially chosen over efficacy data. Population estimates were based on 1990 census data.¹⁶ In addition, several national sur-

veys were used to provide population-based estimates, including the 1990 and 1992 National Health Interview Surveys,^{17, 18} (NHIS) to provide estimates of smoking prevalence and smoking cessation attempts, and the National Health and Nutrition Examination Survey-I (NHANES-I) and the NHANES Epidemiologic Followup Survey² to provide the probability of smoking relapse.

Estimates of the rate of use of nicotine replacement in the OTC scenario were based on marketing surveillance of nicotine replacement therapy use, performed by Shiffman and colleagues.¹⁴ These investigators determined the ratio of use of nicotine products for non-prescription availability compared with prescription availability. We used this ratio multiplied by our estimates for prescription use of nicotine replacement therapy to calculate the rates of use in the over-the-counter setting.

Smoking cessation rates for NRT quitters under both scenarios were derived from a prospective trial of simulated non-prescription nicotine patch use.¹⁹ As noted, we use nicotine patch data as a proxy for nicotine replacement therapy in general, due to the availability of the data on over-the-counter use for this form of replacement. A prospective cohort study was conducted using 2367 participants recruited from public locations such as shopping malls; participants purchased patches at estimated retail price, and were followed up to determine quit rates. Participants lost to follow up in this study were considered to have relapsed. We assume for this analysis that the six-month quit rates for smokers using nicotine replacement was equivalent in the OTC and Rx scenarios. Post-marketing surveillance using retrospective cohort data on prescription nicotine patch use¹⁹ suggests that the six-month quit rate may actually be lower in the prescription setting. Thus, this assumption is a conservative one which will bias the analysis in favour of the prescription scenario by underestimating the over-the-counter public health benefit. We examine changes in this assumption in sensitivity analysis.

Whenever possible, age-specific and sex-specific data were used in the model. All quit rates are based upon self-reported continuous quit rates which were the most consistently available data. Table 1 provides a summary of parameters used for the baseline case for the model. (Parameter estimates stratified by age and sex from these studies are available in a technical report available on request from the authors.)

THE DECISION MODEL

A decision tree was constructed (figure 1) to estimate the number of current smokers who would quit long-term (six months) in the OTC and Rx scenarios for each age and sex stratum. In both scenarios, a smoker has a chance of making a quit attempt using nicotine replacement therapy, a chance of making a quit attempt without nicotine replacement, and a chance of not making a quit attempt. We assume for the baseline analysis that the total

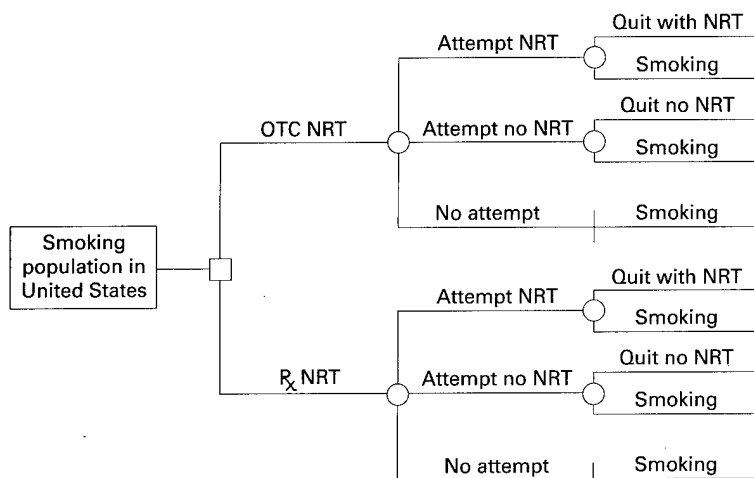

Figure 1 Decision tree for determining the public health benefits of the two scenarios of availability of nicotine replacement therapy. Public health benefits shown in the tree include the number of quit attempts and the number of long-term (six-month) quits. NRT = nicotine replacement therapy, OTC = over the counter, Rx = prescription.

Table 2 Baseline results

	R Scenario*	OTC Scenario†
Number of adult smokers in the United States	47 002 476	47 002 476
Number willing to try NRT per year	1 014 630	2 556 867
Willing to try NRT per year (%)	2.2	5.4
Quit rate of smokers using NRT at six months (%)	10.8	10.8
Number of quits using NRT at six months	109 685	276 405
Gain in number of quits for OTC scenario at six months	NA	91 151
Total number of quits at six months	420 330	511 480
Life expectancy of average smoker (years)	34.211	34.407
Gain in life expectancy for average smoker (years)	NA	0.196
Smoking-attributable mortality rate (based on six-month data) (deaths per year)	412 617	412 269
Reduction in smoking-attributable mortality rate (based on six-month data) (deaths per year)	NA	348 (0.1%)
Reduction in smoking-attributable mortality rate for OTC scenario (based on five-year data) (deaths per year)	NA	2940 (0.7%)

*Nicotine replacement therapy (NRT) available only by prescription.

†Nicotine replacement therapy available over the counter (OTC).

NA = not applicable.

chance of making a quit attempt by any method is the same for both scenarios. We also assume that any patterns in changes of use of other smoking cessation methods, such as behavioural counseling, would not significantly affect cessation rates for smokers quitting without nicotine replacement in either scenario of nicotine replacement availability. Both of these assumptions were examined in sensitivity analysis.

Markov state-transition models²⁰ were created to estimate the life expectancy of an average person in each stratum. Each model consisted of five states, representing: current smokers; those quitting for a year or less; those who have quit for one to two years; long-term quitters; and those who have died. These state transition models represent each smoker in the simulation as being in one of the five mutually exclusive states for any particular one-year period. Probabilities were calculated for a person in one state (for example, long-term quitter) to transition to any other state (such as smoking) in the following year. The three quit states allow representation of a lower relapse rate for longer term quitters (more than two years) compared with more recent quitters.² Mortality for current and former smokers was

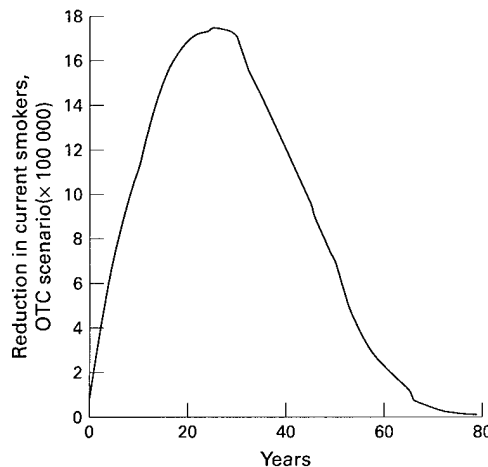

Figure 2 Reduction in the number of smokers in the over-the-counter (OTC) scenario compared with the prescription (R) scenario, over time. The reduction is based on the difference in current smokers between the two scenarios, adjusted to the population size of the OTC scenario, for the original cohort of 47 million adult smokers.

stratified by age and sex,^{1 18 21} however, data were not available to calculate this parameter for duration of cessation, so rates are independent of duration of abstinence for former smokers.

For each age and sex stratum, the initial distribution of cohort members across the states was determined by the outcome of the decision tree for that stratum. The model calculated life expectancy until the surviving members of the cohort reached age 100. Transition probabilities for the Markov models were age and sex dependent.

Results

BASELINE RESULTS

Major outcomes of the analysis are shown in table 2. Key findings are that making nicotine therapy available over the counter would result in approximately 1.1 million additional smokers attempting to quit using nicotine replacement therapy in the first six months, and an estimated 91 151 additional smokers would have quit at the end of six months. The number of additional quitters from the current cohort of smokers would continue to increase over time to a maximum of 1.7 million additional quitters at 25 years in the OTC scenario compared with the R scenario (figure 2).

Reclassifying nicotine therapy as non-prescription would also have a positive impact on life expectancy. Across the total cohort of more than 47 million smokers (including continuing smokers and eventual quitters), the average smoker could be expected to live 0.20 years (2.4 months) longer in the over-the-counter scenario than in the prescription scenario (table 2). The impact of permanently quitting smokers on gain in life expectancy on successful quitters is presented in table 3. On average, each of these new quitters will gain an average of 4.4 years of life compared with smokers who never quit. Thus, the average gain in life expectancy represents a large life expectancy gain that accrues to the small percentage of smokers who would quit in the non-prescription availability setting but not in the prescription setting.

Based on the proportion of quitters at six months in the OTC scenario compared with that in the R scenario, we estimated a reduction in the all-cause, smoking-attributable mortality rate of 348 deaths per year. At five years, our model predicts a decrease in the all-cause, smoking-attributable mortality rate of 2940 deaths per year for the over-the-counter scenario, due to the increased

Table 3 Gain in life expectancy* for smokers who successfully quit smoking

Age	Men	Women	Total
18-24	6.30	4.01	5.28
25-44	5.85	3.78	4.92
45-64	4.26	3.43	3.86
≥65	1.91	1.33	1.59
Total	5.22	3.47	4.41

*Gain in life expectancy (years) for individual smokers who successfully and permanently quit smoking today, compared with smokers who continue to smoke for the rest of their lives. Totals represent average life expectancy weighted by the number of people in each age and sex stratum.

Table 4 Sensitivity analyses

Parameter*	Gain in number of quits at six months (OTC scenario)	Gain in life expectancy† (OTC scenario)
Baseline	91 151	0.196
Change in probability of attempting to quit by any method (baseline average = 0.31)‡		
0.75 *baseline (average = 0.23)	68 363	0.163
1.25 *baseline (average = 0.39)	113 939	0.222
Two quit attempts per year for those attempting to quit by any method (baseline = 1 per year)	180 661	0.266
Relative chance of quit attempt by any method, OTC to R (baseline 1 to 1):		
0.9 to 1	40 003	0.108
1.1 to 1	142 299	0.280
1.3 to 1	244 595	0.437
Threshold value§: 0.79 to 1		
Probability of using NRT should a quit attempt be made (both scenarios; baseline average = 0.14 R, 0.36 OTC)‡		
0.5 *baseline (average = 0.07 R, 0.18 OTC)	45 576	0.104
0.75 *baseline (average = 0.11 R, 0.27 OTC)	68 363	0.152
1.25 *baseline (average = 0.18 R, 0.45 OTC)	113 939	0.238
Threshold value§: 0		
Relative chance of using NRT for those quitting in OTC scenario compared with chance of using NPT in R scenario (baseline average = 2.52 to 1)‡		
0.5 *baseline (average = 1.26 to 1)	15 592	0.035
0.8 *baseline (average = 2.02 to 1)	60 927	0.133
1.2 *baseline (average = 3.02 to 1)	121 375	0.257
Threshold value§: 0.40; *baseline (average = 1 to 1)		
Probability of a successful quit at six months for those attempting with NRT in the R scenario (OTC scenario probabilities held constant; baseline average = 0.106)‡		
1.25 *baseline (average = 133)	63 730	0.137
1.5 *baseline (average = 0.159)	36 309	0.080
2.0 *baseline (average = 0.212)	(18 534)	(0.029)
Threshold value§: 1.86; *baseline (average = 0.197)		
Probability of a successful quit at six months for those attempting with NRT in the OTC scenario (R scenario probabilities held constant; baseline average = 0.106)‡		
0.5 *baseline (average = 0.053)	(47 052)	(0.096)
0.75 *baseline (average = 0.080)	22 050	0.055
1.25 *baseline (average = 0.133)	160 252	0.326
Threshold value§: 0.66 *baseline (average = 0.070)		
Probability of a successful quit at six months for those attempting with NRT (baseline average 0.106 R, 0.106 OTC)‡		
1.2 *baseline in R scenario (average = 0.127) and, 0.8 *baseline in OTC scenario (average = 0.084)	13 933	0.037
Probability of a successful quit at six months for those attempting without NRT (baseline average = 0.049)‡		
0.8 *baseline (average = 0.039)	106 265	0.235
1.2 *baseline (average = 0.059)	76 037	0.160
2.0 *baseline (average = 0.098)	15 581	0.040
Threshold value§: 2.3; *baseline (average = 0.113)		
Probability of a successful quit at six months for fraction of those attempting without NRT but with non-pharmacological therapy in OTC scenario (baseline average = 0.049)‡		
0.75 *baseline (average = 0.037)	32 382	0.115
0 *baseline (average = 0)	(143 924)	(0.150)
Threshold value§: 0.41 *baseline (average = 0.020)		

NRT = nicotine replacement therapy; OTC = over the counter, R = prescription.

*Changes in parameters noted as a multiplier; *baseline represents the values of the parameter across age and sex strata multiplied by the number to achieve the result listed.

†Measured in average years of life gained for an individual smoker.

‡The weighted average is the average of the values across age and sex strata adjusted to the American adult smoking population. These numbers are provided for reader reference; the analyses were performed using adjustment of each of the strata by the multiplier listed.

§The threshold value is the value of the parameter at which the life expectancy is equal in both the R and the OTC scenarios.

number of quitters in this scenario compared with the prescription scenario (table 2). For the original cohort of 47 million smokers, this gap between the smoking attributable mortality in the non-prescription setting and the prescription setting would continue to widen for approximately 30 years.

SENSITIVITY ANALYSES

Results of the sensitivity analyses demonstrated that the model results were robust for a wide range of changes in the baseline parameters (table 4). The results were most sensitive to changes in the parameter values of the relative chance of making a quit attempt by any method, and the relative probabilities of a successful quit at six months for the OTC and R scenarios. If, for example, the smokers are 10% more likely to attempt to quit by any method in the OTC scenario compared with the R scenario, then the gain in number of quits at six months for the OTC scenario increases by 56% over baseline, and the gain in life expectancy for the OTC scenario increases

by 43%. Conversely, if either the chance of a successful quit at six months is either twice what we predict for the R scenario, or a half of what we predict for the OTC scenario, then the R scenario has more quitters and a better life expectancy.

Threshold values from the sensitivity analyses are also shown in table 4. Threshold values are the values of the model parameters at which there is no longer a life expectancy benefit for smokers in the non-prescription scenario compared with the prescription scenario. For example, if smokers were only 79% as likely (or less) to attempt to quit by any method in the OTC scenario compared with the R scenario, then the OTC scenario would not have a life expectancy advantage.

Discussion

Smoking is a major source of morbidity and mortality in the United States. Thus, policies that even modestly improve smoking cessation rates have the potential to yield large public health benefits. In this analysis, we show that

making nicotine replacement therapy using transdermal patches and nicotine gum available over the counter rather than prescription-only would result in a large increase in the number of successful quitters each year, a reduction in smoking-attributable mortality, and an increase in the life expectancy of smokers. The gain in life expectancy for an average smoker in the over-the-counter setting is 0.196 years; in comparison, the gain in screening 40-year-old men and 40-year-old women for hypertension would be an increase in life expectancy of 0.03 years and 0.01 years, respectively.²²

Sensitivity analyses demonstrate that the over-the-counter use has a relative benefit compared with prescription use under a wide variety of assumptions. Perhaps the area of greatest uncertainty within the analysis is the six-month effectiveness data for both prescription and non-prescription nicotine replacement therapy. Data are available on NRT-assisted quit rates⁵; these represent primarily efficacy results of clinical trials. In contrast, the analyses in this model used data estimating effectiveness of nicotine replacement under the OTC scenario. Surveillance data suggest that effectiveness of prescription-only patch use may have a 40% lower six-month success rate than we use for the baseline model.¹⁹ Potential quitters willing to use NRT as an over-the-counter medication may, on average, have fewer or less severe factors for relapse.²³ In contrast, smokers who seek cessation services (including NRT) through health-care providers may, on average, include people with a greater number or level of relapse risk factors.¹⁰ If the six-month cessation rate for prescription use nicotine therapy is lower than we have estimated, then the actual benefits would be greater than we have calculated. Even if the six-month cessation rates for non-prescription nicotine replacement therapy use are 20% worse than we have estimated, and that of the prescription nicotine replacement use 20% better than estimated, our model still predicts a small benefit for the non-prescription availability setting.

There are several caveats that should be considered when evaluating our results. First, there are no randomised clinical trial data linking NRT-based smoking cessation programmes to overall reduction in mortality. Next, we do not explicitly address the issue of adverse effects of nicotine replacement. Since the analysis only addresses mortality associated with smoking, we did not include adverse effects because death directly attributable to NRT therapy itself is an exceedingly rare event, and thus would not change the results of the analysis. Other adverse effects of nicotine replacement therapy—for example, skin irritation from the transdermal patch—tend to be transitory and produce little impact on overall health. Finally, we do not address the economic impact of making nicotine replacement available without prescription.

Overall, we have found that making nicotine replacement therapy available without prescription would result in substantial public

health benefit. By implementing a policy to make nicotine patches and gum available as over-the-counter medications for smoking cessation, the number of current smokers would significantly decrease over time, and smoking-attributable mortality would decline as well.

This study was funded by a grant from SmithKline Beecham. Dr Lawrence is supported in part by Contract DAMD 17-96-C-6069, "Breast Cancer Support Contract," from the Department of the Army. Dr Fiore has done consulting and public speaking for the following pharmaceutical companies: SmithKline Beecham, Ciba-Geigy, McNeil, and GlaxoWellcome.

- 1 US Department of Health and Human Services. *Reducing the health consequences of smoking: 25 years of progress. A report of the Surgeon General, 1989*. Rockville, Maryland: Public Health Service, Centers for Disease Control, Office on Smoking and Health, 1989. (DHHS Publication No (CDC) 89-8411.)
- 2 US Department of Health and Human Services. *The health benefits of smoking cessation. A report of the Surgeon General, 1990*. Rockville, Maryland: Public Health Service, Centers for Disease Control, Office on Smoking and Health, 1990. (DHHS Publication No (CDC) 90-8416.)
- 3 Gallup G Jr, Newport F. Many Americans favor restrictions on smoking in public places. *Gallup Poll Monthly* 1990;298:19.
- 4 Cohen S, Lichtenstein E, Prochaska JO, et al. Debunking myths about self-quitting: evidence from 10 prospective studies of persons who attempt to quit smoking by themselves. *Am Psychol* 1989;44:1355-65.
- 5 Fiore MC, Smith SS, Jorenby DE, et al. The effectiveness of the nicotine patch for smoking cessation: a meta-analysis. *JAMA* 1994;271:1940-7.
- 6 Silagy C, Mant D, Fowler G, et al. Meta-analysis on efficacy of nicotine replacement therapies in smoking cessation. *Lancet* 1994;343:139-42.
- 7 Orleans CT, Resch N, Noll E, et al. Use of transdermal nicotine in a state-level prescription plan for the elderly—a first look at "real-world" patch users. *JAMA* 1994; 271:601-7.
- 8 Pierce JP, Gilpin E, Farkas AJ. Nicotine patch use in the general population: results from the 1993 California Tobacco Survey. *J Natl Cancer Inst* 1995;87:87-93.
- 9 Fiore MC, Novotny TE, Pierce JP, et al. Methods used to quit smoking in the United States—do cessation programs help? *JAMA* 1990;263:2760-5.
- 10 Lichtenstein E, Hollis J. Patient referral to a smoking cessation program: who follows through? *J Fam Pract* 1992;34:739-45.
- 11 Marion Merrell Dow, Inc. *Nicoderm (Nicotine transdermal system) prescribing information*. Kansas City, Missouri: Marion Merrell Dow, 1991.
- 12 Fiore MC, Jorenby DE, Baker TB, et al. Tobacco dependence and the nicotine patch: clinical guidelines for effective use. *JAMA* 1992;268:2687-94.
- 13 Benowitz NL. Nicotine replacement therapy: what has been accomplished—can we do better? *Drugs* 1993;45:157-70.
- 14 Shiffman S, Gitchell J, Pinney JM, et al. Public health benefit of over-the-counter nicotine medications. *Tobacco Control* 1997;6:306-10.
- 15 Sox HC, Blatt MA, Higgins MC, et al. *Medical decision making*. Boston, Massachusetts: Butterworths, 1988.
- 16 US Department of Commerce. *Statistical abstract of the United States 1994*, 114th ed. Washington, DC: Department of Commerce, 1994.
- 17 US Centers for Disease Control. Cigarette smoking among adults—United States, 1990. *MMWR* 1992;41:354-5, 361-2.
- 18 US Centers for Disease Control. Cigarette smoking-attributable mortality and years of potential life lost—United States, 1990. *MMWR* 1993;42:645-9.
- 19 SmithKline Beecham, Marion Merrell Dow. *Supplement to FDA application 20-165 for approval of Nicoderm 21 mg/day, 14 mg/day, 7 mg/day*. Pittsburgh, Pennsylvania: SmithKline Beecham; Kansas City, Missouri: Marion Merrell Dow.
- 20 Beck JR, Pauker SG. The Markov process in medical prognosis. *Med Decision Making* 1983;3:420-58.
- 21 Thun MJ, Day-Lally C, Myers DG, et al. Trends in tobacco smoking and mortality from cigarette use in Cancer Prevention Studies I (1959-1965) and II (1982-1988). In: *Changes in cigarette-related disease risks and their implications for prevention and control*. Bethesda, Maryland: National Cancer Institute, 1997: chapter 4. (NCI Monograph No 8.)
- 22 Littenberg B, Garber AM, Sox HC. Screening for hypertension. *Ann Intern Med* 1990;112:192-202.
- 23 Killen JD, Fortmann SP, Kraemer HC, et al. Who will relapse? Symptoms of nicotine dependence predict long-term relapse after smoking cessation. *J Consult Clin Psychol* 1992;60:797-801. Hughes JR, Gulliver SB, Fenwick JW, et al. Smoking cessation among self-quitters. *Health Psychol* 1992;11:331-4.
- 24 Hughes JR, et al. Smoking cessation among self-quitters. *Health Psychol* 1992;11:331-4.

An Exploratory Model of the Relationships Between Personal and Structural Factors and Patterns of Preventive Health Behaviors

Submitted by

Wenchi Liang, Ph.D.*
Mona C. Shediac-Rizkallah, Ph.D.†
William F. Lawrence, M.D., M.S.E.*
David D. Celentano, Sc.D.‡
Jeanne S. Mandelblatt, M.D., M.P.H.§

* Cancer Clinical and Economics Outcomes Core, Vincent T. Lombardi Cancer Center, Georgetown University Medical Center, Washington, D.C.

† Department of Health Behavior and Education, American University of Beirut, Lebanon

‡ Department of Epidemiology, The Johns Hopkins School of Hygiene and Public Health, Baltimore, Maryland

§ Cancer and Aging Research, and Cancer Clinical and Economics Outcomes Core, Vincent T. Lombardi Cancer Center, Georgetown University Medical Center, Washington, D.C.

For correspondence and reprint requests, please contact:

Wenchi Liang, Ph.D.

2233 Wisconsin Avenue, NW, Suite 430

Washington, D.C. 20007

(202) 687-8937 (voice)

(202) 687-0305 (facsimile)

liangw@gunet.georgetown.edu

Funding: Supported in part by contract DAMD 17-96-C-6069, "Breast Cancer Support Contract,," from the Department of the Army.

Running title: Factors influencing preventive health behaviors

Word count: 3,468 (including Abstract)

Abstract

Background: Based on our conceptual framework, we investigated the influence of behavioral determinants on patterns of preventive health behaviors across age and gender groups.

Methods: The data (n=4,052) came from the 1990-1992 Maryland Behavioral Risk Factor Surveillance System surveys. Medical and cholesterol checkups, mammography, clinical breast examination (CBE), and Pap smear (PAP) tests for each gender and age (18-24, 25-39, 40-54, and 55+) group were determined by factor analysis. We used logistic regression to analyze the relationships between socioeconomic status, health status, marriage, family support, and sources of routine medical checkups (SRC) and behavioral clusters.

Results: Having health problems was associated with adherence to medical and cholesterol checkups among men; visiting an OB/GYN was related to PAP, CBE, and medical checkup behaviors among females 18-39 years of age. A higher household income was associated with cancer screening among females age 55 and older. Being married or not living alone was associated with getting checkups among younger males.

Conclusions: SES, health status, family support, and SRC explained variations in patterns of screening and checkup behaviors differentially across age and gender groups. Future research is needed to extend this model and include other key determinants, and to examine these relationships prospectively.

Key Words: Preventive health services/utilization; breast neoplasms/prevention and control; mass screening; age groups; sex; socioeconomic factors; marital status; health status; models, theoretical; cross-sectional studies

Introduction

Behavioral theories or models have been used to explain why people do or do not practice a variety of health behaviors. Applied psychological models emphasize the influences of individual cognitive and affective factors such as beliefs, attitudes, and fear;¹⁻³ while others have considered the influence from social and environmental contexts.⁴⁻⁷ Both approaches find significant associations between individual health behaviors and selected factors,⁸⁻¹⁰ suggesting that preventive health behaviors are determined not only by individual knowledge and perceptions, but also by external reinforcement and environmental conditions.

People seek care for or take actions that impact on several related behaviors. For example, having received a Pap smear is strongly associated with mammography use in older women.¹¹ Prior research also suggests that certain individual behaviors such as smoking and drinking are highly correlated,¹²⁻²¹ and that these associations vary according to age^{19,20} and gender.^{15,16} Our prior work²¹ indicates that behaviors involving health risks, cancer screening, and routine medical checkups tend to cluster into distinct groups, and these distinctions remain consistent across gender and age.

Most studies on determinants of health behaviors have only examined single rather than multiple health behaviors; it is not apparent why behaviors cluster into specific groups. One explanation is that behaviors similar in purpose and practice patterns are correlated. Cancer screening behaviors, for instance, depend on a doctor visit; on the other hand, smoking and drinking are mostly practiced for pleasure or experimentation among young people.^{14,20} No previous studies have examined the determinants of groups of screening and checkup behaviors, and whether these relationships vary across gender and age groups. Studies of individual

behaviors have identified determinants of Pap smear,²²⁻²³ mammography,²⁴⁻²⁶ and medical checkup behaviors,²⁷ including personal knowledge, demographic, and psychosocial variables, as well as social support, insurance coverage, and medical care settings. Differences in these determinants may explain variations in patterns of preventive health behaviors.

The purpose of this study was to examine the relationships between groups of routine checkup and cancer screening behaviors and personal characteristics and social context across gender- and age-specific samples. We developed a conceptual framework using components of behavioral models predicting individual behaviors to describe these relationships for related behaviors. We hypothesized that personal disease history would influence medical and cholesterol checkups, and that income levels and sources of routine medical care would predict cancer screening behaviors. We also hypothesized that behavioral clusters in different gender-age groups would have different determinants. In addition, an exploratory analysis was conducted between selective behaviors and predictor factors to test the conceptual framework.

Methods

Conceptual framework

The conceptual framework (Figure 1) used in this study was a modification of Green and Kreuter's⁷ and Anderson and Aday's²⁸ models that emphasize the importance of looking at predisposing, reinforcing, and enabling factors to predict health behaviors and utilities. We adapted McLeroy's ecological approach⁵ and categorized behavioral determinants as intrapersonal (e.g., knowledge and belief), interpersonal (e.g., family members and health professionals), and structural factors (e.g., health care facilities and law). In addition, we added age and gender as modifiers of behavioral clusters,²¹ and socioeconomic factors which directly

and indirectly influence behaviors.²⁹

Data and sample

We used survey data from the Behavioral Risk Factor Surveillance System (BRFSS) in Maryland from 1990 to 1992, after obtaining the approval by the internal review board for ethical considerations of studying human subjects. Briefly, the BRFSS is a nationwide annual telephone survey that collects information about health-related behaviors in randomly selected adults.³⁰ Non-institutional households in Maryland were selected by Waksberg's method of "multistage cluster design"³¹ for random digit dialing. Each cluster consisted of 100 telephone numbers, of which 3 were randomly selected. After reaching a household, a trained interviewer selected an adult age 18 and older for interview using the Kish respondent selection routine.³² The computer-assisted telephone interview system was used to facilitate respondent selection, data entry, and error correction. During 1990 to 1992, 5584 respondents completed the interview, of which 1532 (27%) observations were excluded due to missing data.

The final sample of 4052 respondents was divided into 8 groups based on gender and age (18-24, 25-39, 40-54, 55+) categories. We defined the younger adults as 18 to 24 years in order to capture their unique behavioral patterns as the result of peer influence and experimentalism suggested by the literature.³³ Based on exploratory analysis, we grouped age 40 to 54 and 55 and older to distinguish middle-aged and older adults from younger age groups.²¹

Clusters of screening and checkup behaviors

Age- and gender-specific screening and checkup behaviors were selected from the results of our previous research on the same population.²¹ Briefly, oblique rotated factor analysis was used to determine clusters from 11 behaviors, including the amount of exercise, current smoking,

alcohol consumption, fruit and vegetable consumption, seatbelt use, driving after drinking, and time since last medical checkup, cholesterol test, mammographic screening, clinical breast examination, and cervical cancer screening. Factor analysis showed 3 behavioral clusters for each gender-age group. Checkup and screening behaviors formed independent behavioral groups that were distinct from other behaviors, a phenomenon consistent across gender-age groups. Medical and cholesterol checkup behaviors clustered together for all male groups, and more people practiced both behaviors as age increased. Pap smear and clinical breast examinations correlated with medical checkups among all females except for those in the oldest age group. In the oldest female group, three women's cancer screening behaviors and medical and cholesterol checkups formed separate behavioral groups.

Factors predicting groups of health behaviors

Based on our conceptual framework, four types of factors were examined: socioeconomic factors, including race, education, employment status, and household income; intrapersonal factors, including obesity (body mass index equal or greater than 27.8 for males and 27.2 for females) and the presence of various health problems such as high blood cholesterol, high blood pressure, diabetes, hysterectomy, and breast problems or cancer; interpersonal factors, including marital status and size of the household; and the structural factor, represented by the source of routine medical checkups. These determinants are shown in Figure 1. Size of the household was used as a proxy for family support. Marriage was considered one form of social support,³⁴ and was coded as “never married,” “married or living together,” and “ever married” (including separated, divorced, or widowed) to evaluate its impact on preventive health behaviors. The source of routine checkups was defined as type of physician from which subjects

sought care, and were categorized into family/general, internist, obstetrician/gynecologist (OB/GYN), and others (including specialists).

Data analysis

The analyses were performed using SAS version 6.07.³⁵ Cases with missing data on the income variable were retained in the “missing” category. For each behavioral cluster, we conducted gender- and age-specific logistic regressions to examine the behavioral determinants. Ten logistic models were analyzed. Checkup and screening behaviors were dichotomized as either receiving this service within the past 12 months or not. The final multi-variate comparison was made between those who performed all of the behaviors clustered in one group and those who did not.

Results

Response rate

The overall survey response rate for the 1990-1992 BRFSS surveys was 82% (n=5584). Among these respondents, 1532 (27%) with missing data were excluded from analyses. Individuals with missing data were more likely to be older, female, nonwhite, retired or without jobs, with less household income, and lower education than the original sample. However, the frequency distributions of age, sex, race, income, education, and employment status in the final sample of 4052 was similar to that in the original sample. The level of household income was missing for 618 respondents; these subjects were generally older, had lower education and more often unemployed than those who reported their income level.

Descriptive analysis of the study population

The frequencies of the predictor variables for each gender and age group are summarized

in Table 1. The distribution of sociodemographic variables differed significantly across gender and age groups. Older age was associated with more prevalent health problems such as high blood pressure and diabetes but less obesity. More than one-third of the female respondents younger than 40 years old identified an obstetrician/gynecologist as their primary source of routine checkups; this proportion dropped to 7% among females age 55 and older. While the proportion visiting other types of doctors, like specialists, remained constant across age groups, the proportion visiting internists increased with age.

Determinants of behavioral patterns

Table 2 summarizes the significant determinants of behavioral clusters in each gender-age group. Briefly, among the intrapersonal factors, having health problems was significantly associated with checkup behaviors across all age and gender groups, and having breast problems was an important factor predicting women's cancer screening behaviors among older females (OR=2.44, 95% confidence interval 1.33 to 4.35). Interpersonal factors, such as household size and marriage, were associated with checkup behaviors among male ages 18-24 and 25-39 years, but were not significantly related to any behaviors among females. Having an OB/GYN as the source of routine checkups was associated with screening and checkup behaviors among females age 18-39, but was associated with less adherence to medical and cholesterol checkups among older females. Nonwhites were more likely to report checkup and screening behaviors, and economic factors such as income and employment predicted behaviors among females.

Testing of the conceptual framework

To test the conceptual framework and examine relationships among predictor variables, we selected the cluster of cancer screening behaviors among women age 55 and older, since most

predictors that were significant at the bivariate level (Table 3) became insignificant in the multivariate analysis. We found that employment status, education, size of the household and marital status indirectly influenced behaviors through household income (Figure 2). Living alone was associated with ever being married, and both were associated with low household income. On the other hand, living with another adult was associated with being married, and both were associated with high household income. Having high school or less education was associated with low income, but being employed was associated with high income. In addition, women with breast problems were more likely to visit OB/GYNs than those without breast problems, indicating the association between intrapersonal and structural factors.

Discussion

This is the first population-based study to our knowledge to examine multidimensional patterns of screening and checkup behaviors and their determinants across different ages and genders. Our results demonstrate that health behaviors are complex and vary among gender-age groups. In concordance with our conceptual framework, we found that variations in clusters of checkup and screening behaviors can partly be accounted for by variations in the influence of socioeconomic, intrapersonal, interpersonal, and structural factors across different gender-age groups. Among the factors tested in our study, the presence of health-related problems, such as high blood pressure and cholesterol, predict the cluster of medical and cholesterol checkups in all gender-age groups except for young men; and visiting an OB/GYN predicting Pap smear, CBE, and medical checkup behaviors among women 18 to 39 years of age, but not among females 40-54 years of age. The results support our second hypothesis that same behavioral clusters have different contributing factors in different gender-age groups.

The significant association between poorer health status and medical and cholesterol checkup behaviors among males coincides with the notion that males seek medical help when encountering diseases rather than being concerned with disease prevention.³⁶ However, because of the cross-sectional nature of the data, the relationship between health status and checkup behaviors may have an alternative explanation: Those who did not go for regular checkups may have less opportunity for conditions to be diagnosed.

The importance of the one structural factor we evaluated--the source of routine medical checkups--in the utilization of health services has been demonstrated in previous studies, especially among females. Hedegaard³⁷ studied factors associated with mammographic screening among low-income females 40 years and older and found that the number of visits was a stronger predictor of receiving a mammogram than race and age. Similar findings have been reported among women of reproductive age,³⁸ older women with regular physicians,¹¹ and women aged 55 to 74 covered by insurance.³⁹ Our finding of a positive association between having OB/GYNs as the source of routine checkups and receiving Pap tests, clinical breast examination, and medical checkups among age 18-39 females is consistent with the literature.⁴⁰⁻⁴¹ However, females age 55 and older who had OB/GYNs as their source of routine medical checkups practiced fewer medical and cholesterol checkup behaviors, compared to those who visited general physicians. Since visiting OB/GYNs is associated with more breast problems in this age group, it is very likely that OB/GYNs spend more time caring for older women's disease-specific needs and payed less attention to recommendations for routine medical checkups than general practice physicians.

Despite a history of underuse of preventive health services, nonwhites in our study

reported higher levels of checking and screening behaviors among middle-aged males and females. This is consistent with recent findings from the National Health Interview Survey.^{22, 42-43} For instance, use of Pap test and mammographic screening have been increasing throughout the past two decades, especially among African Americans. While whites have a higher percentage of ever having a Pap test, African Americans tend to have a higher rate of recent screening.^{22,43} The discrepancy in rates of mammographic screening between whites and nonwhites disappeared when comparing the 1992 to the 1987 national survey data.⁴³ Our findings and prior research demonstrate the fact that cancer screening programs targeting African American women have been successful in promoting cancer screening.⁴⁴

Income was significantly associated with the use of women's cancer screening services among older females, but not their checkup behaviors. This suggests that the relative high cost of women's health care involving mammography and lack of health insurance coverage remain obstacles to these preventive health behaviors. Blustein⁴⁵ has noted the importance of supplemental insurance coverage in predicting mammography use among Medicare beneficiaries. Starting in 1998, Medicare covered annual screening mammography, and has eliminated all copayments and deductibles. Therefore, barriers to mammography may be significantly reduced for women 65 years of age and older in the future.

Interpersonal factors, such as the size of the household and marital status, were significant predictors among age 18-24 and 25-39 males, but not among females. The positive association between household size and checkup behaviors among younger males implies that those who lived alone may have lacked information and encouragement to obtain regular medical visits, although no firm conclusion can be drawn from these data. Household size is a measure of

family influence, and its influence on health behaviors needs to be clarified by using more comprehensive measures of social support.³⁴ According to Umberson,⁴⁶ marriage provides an interpersonal bond for social control that leads spouses to be mutually responsible for one another's health and behaviors. This control is more often exercised by wives rather than husbands, which implies marriage may be more beneficial to males in terms of health. In addition, our finding of an indirect influence of marital status and household size in cancer screening behaviors through household income among women 55 years of age or older implies that these factors measure financial support from family members.

Several limitations of the study should be considered in evaluating our results. First, the cross-sectional BRFSS data do not allow us to draw causal relationships between behavioral patterns and their determinants, and the telephone survey is subject to recall, self-report, and selection biases.⁴⁷ We used a conceptual framework derived from prior behavioral models as the guide to interpret the results, but causal directions can only be established by using prospective data. Recall and selection biases were minimized since people accurately recall their most recent screening behaviors in the past year⁴⁸⁻⁴⁹ and the telephone coverage in Maryland is above 97%.⁵⁰ However, the overall 82% response rate for the BRFSS survey and the demographic differences between our final sample and the excluded respondents limit our ability to generalize the results to the Maryland population. The social desirability effect due to the self-report should also be taken into account, but it occurs less often in telephone surveys than in face-to-face interviews.⁴⁷

Second, dichotomizing health behaviors allowed us to compare only those who performed all the desirable behaviors to those who did not; therefore, no distinction between those who performed some of the desirable behaviors and those who performed none could be

made. However, index scales (defining the outcome as the number of desirable behaviors performed) have been criticized for their inability to demonstrate construct validity as the measure of risk behaviors, and might create difficulties in interpreting the results.⁵¹ Our simplified definitions of groups of behaviors minimized this ambiguity, and allowed us to examine the factors relating to optimal screening adherence.

Third, several important predictors are not available in this study. Two areas that were not included are of great importance: cognitive and affective attributes such as attitudes, knowledge, self-efficacy, stress, and fear; and additional domains of social support including supports from friends, family members, and peers, and emotional and informational support. In addition, we did not have enough information about structural variables, which are important correlates of preventive health behaviors. Types of health insurance and frequencies of health service utilization, for instance, have been found to modify screening and checkup behaviors,^{23,37-39} but were not measured in the BRFSS.

Since risk-taking and screening behaviors form distinct groups and have different determinants in different age and gender groups, our data suggest that effective health promotion programs will target multiple risk-taking or screening behaviors separately by age and gender. For instance, the messages to encourage older women to get breast and cervical cancer screening can be combined. Findings of the relationships between screening and checkup behaviors and their determinants also suggest that public health interventions should respond to non-adherent people differently in age- and gender-specific groups. For instance, to increase cancer screening behaviors among older women, one can target those with a low income; to promote checkup behaviors among young men, one would target those with little social support. Determinants that

are mutable, such as the source of routine checkups, could also be a focus of public health interventions. While encouraging OB/GYNs to recommend women's cancer screening behaviors may be important and effective, they should stress reaching older women. Interventions should also emphasize the roles of general or family physicians in promoting regular checkup and screening behaviors among their patients, particularly older women, which can be disseminated effectively during routine medical visits.

Our results also highlight the importance of considering age and gender differences in behavioral determinants. Although the same behavioral clusters may occur in different age-gender groups, their determinants and relative significance may not be the same. For example, having OB/GYNs as the primary source of medical checkups predicted the practice of Pap smears, clinical breast examination, and medical checkups among 18-24 and 25-39 year old females, but being nonwhites was the most significant predictor for these behaviors among age 25-39 females. Therefore, interventions should not only focus on OB/GYN's role, but should also target middle-aged and older white women.

In summary, behavioral patterns differ across ages and genders, and each behavioral cluster is influenced by different factors to varying degrees. Our proposed model suggests a comprehensive approach to examine the relationships between these health-related behaviors and their influences, and takes into account the modifying effect of age and gender. Prospective research is needed to examine the causal relationships between behaviors and factors, and include key elements such as social support and the health care environment, in addition to sociodemographic information.

ACKNOWLEDGMENTS

This article is based on doctoral research completed in the Faculty of Social and Behavioral Sciences, Department of Health Policy and Management, the Johns Hopkins School of Hygiene and Public Health.

The permission of the use of Maryland BRFSS data (1990-1992) came from Office of Public Health Assessment, Community and Public Health Administration, in the Maryland Department of Health and Mental Hygiene. We thank Dr. Norma Kanarek and Ms. Aylse Weinstein for their generous help on data management and background information.

References

1. Rosenstock IM. The health belief model and preventive health behavior. *Health Educ Monograph* 1974;2:354-86.
2. Fishbein M, Ajzen I. *Belief, Attitude, Intention and Behavior*, Reading, MA:Addision-Welsey, 1975.
3. Weinstein ND. The precaution adoption process. *Health Psychol* 1988;7:355-86.
4. Bandura A. *Social Foundation of Thought and Action: A Social Cognitive Theory*. Englewood Cliffs, NJ: Prentice Hall, 1995.
5. McLeroy KR, Bibeau D, Steckler A, Glanz K. An ecological perspective on health promotion programs. *Health Educ Q* 1988;15:351-77.
6. Ewart CK. Social action theory for a public health psychology. *Am Psychol* 1991 46:931-46.
7. Green LW, Kreuter MW. *Health Promotion Planning: An Educational and Environmental Approach*. Mountain View, California:Mayfield Publishing Company, 1991, 2nd edition.
8. Palank CL. Determinants of health-promoting behavior: A review of current research. *Nurs Clin North Am* 1991;26:815-32.
9. Montano DE, Thompson B, Taylor VM, Mahloch J. Understanding mammography intention and utilization among women in an inner city public hospital clinic. *Prev Med* 1997;26:817-24.
10. Diehr P, Koepsell T, Psaty BM, Wagner E, Curry S. Do communities differ in health behaviors? *J Clin Epidemiol* 1993;46:1141-9.
11. Mayer-Oakes SA, Archison KA, Matthias RE, Jong FJ, Lubben J, Schweitzer SO.

- Mammography use in older women with regular physicians: What are the predictors? *Am J Prev Med* 1996;12:44-50.
12. Williams AF, Wechsler H. Interrelationship of preventive actions in health and other areas. *Health Serv Rep* 1972;87:969-76.
 13. Langlie JK. Interrelationships among preventive health behaviors: A test of competing hypotheses. *Public Health Rep* 1979;94:216-25.
 14. Kannas L. The dimensions of health behavior among young men in Finland. *Int J Health Educ* 1982;24:146-55.
 15. Kronenfeld JJ, Goodyear N, Pate R, Blair A, Howe H, Parker G, et al. The interrelationship among preventive health habits. *Health Educ Res* 1988;3:317-23.
 16. Ungmack JA. Patterns of personal health practice: men and women in the United States. *Am J Prev Med* 1994;10:38-44.
 17. Harris DM, Guten S. Health-protective behavior: an exploratory study. *J Health Soc Behav* 1979;20:17-29.
 18. Tapp JT, Goldenthal P. A factor analytic study of health habits. *Prev Med* 1982;11:724-8.
 19. Hays R, Stacy AW, DiMatteo R. Covariation among health-related behaviors. *Addict Behav* 1984;9:315-8.
 20. Norman RMG. Studies of the interrelationships among health behaviors. *Can J Public Health* 1985;76:407-10.
 21. Liang W, Shediak-Rizkallah M, Celentano D, Rohde C. A population-based study of age and gender differences on patterns of preventive health behaviors. *Am J Prev Med*
 22. Norman SA, Talbott EO, Kuller LH, Krampe BR, Stolley PD. Demographic, psychological,

- and medical correlates of Pap testing: a literature review. *Am J Prev Med* 1991;7:219-26.
23. Bernstein AB, Thompson GB, Harlan LC. Differences in rates of cancer screening by usual source of medical care. Data from the 1987 National Health Interview Survey. *Med Care* 1991;29:196-209.
 24. Smith RA, Haynes S. Barriers to screening for breast cancer. *Cancer* 1992;67(7 Suppl.):1968-78.
 25. Stein JA, Fox SA, Murata PJ, Morisky DE. Mammography usage and the Health Belief Model. *Health Educ Q* 1992;19:447-62.
 26. Urban N, Anderson GL, Peacock S. Mammography screening: how important is cost as a barrier to use? *Am J Public Health* 1994;84:50-5.
 27. Rakowski W, Lefebvre RC, Assaf AR, Lasater TM, Carleton RA. Health practice correlates in three adult age groups: results from two community surveys. *Public Health Rep* 1990;105:481-91.
 28. Aday LA, Anderson RM. A framework for the study of access to medical care. *Health Serv Res* 1974;9:208-20.
 29. Adler NE, Boyce T, Chensney MA, Cohen S, Folkman S, Kahn RL, et al. Socioeconomic status and health. The challenge of the gradient. *Am Psychol* 1994;49:15-24.
 30. Remington PL, Smith MY, Williamson DF, Anda RF, Gentry EM, Hogelin GC. Design, characteristics, and usefulness of state-based Behavioral Risk Factor Surveillance: 1981-1987. *Public Health Rep* 1988;103:366-75.
 31. Waksberg JS. Methods for random digit dialing. *J Am Stat Assoc* 1978;73:40-6.
 32. Kish L. *Survey Sampling*. New York: John Wiley and Sons, 1965, pp. 396-404.

33. Astone NM, Joffe A, Alexander C, Kanarek N. The social and demographic correlates of smoking among young adults in Maryland. *Am J Prev Med* 1997;13(Suppl 2):25-9.
34. Cohen S, Syme SL. *Social Support and Health* New York: Academic Press, 1985.
35. SAS Institute Inc. *SAS/STAT® User's Guide, Version 6, Fourth Edition, Volume 1*. Cary, North Carolina: Institute Inc., 1989;779-88.
36. Verbrugge LM. Gender and health: an update on hypotheses and evidence. *J Health Soc Behav* 1985;26:156-82.
37. Hedegaard HB, Davidson AJ, Wright RA. Factors associated with screening mammography in low-income women. *A J Prev Med* 1996;12:51-6.
38. Wilcox LS, Mosher WD. Factors associated with obtaining health screening among women of reproductive age. *Public Health Rep* 1993;108:76-86.
39. McCarthy BD, Yood MU, MacWilliam CH, Lee MJ. Screening mammography use: The importance of a population perspective. *Am J Prev Med* 1996;12:91-5.
40. Frazier EL, Jiles RB, Mayberry R. Use of screening mammography and clinical breast examination among black, Hispanic, and white women. *Prev Med* 1996;25:118-25.
41. Mammon JA, Shediak MC, Crosby CB, Sanders B, Matanoski GM, Celentano DD. Inner-city women at risk for cervical cancer: behavioral and utilization factors related to inadequate screening. *Prev Med* 1990;19:363-76.
42. Pearlman DN, Rakowski W, Ehrich B. Mammography, clinical breast exam, and Pap testing: Correlates of combined screening. *Am J Prev Med* 1996;12:57-64.
42. Martin LM, Calle EE, Wingo PA, Heath Jr. CH. Comparison of mammography and Pap test use from the 1987 and 1992 National Health Interview Surveys: Are we closing the gaps?

Am J Prev Med 1996;12:82-90.

44. Hiatt RA, Pasick RJ. Unsolved problems in early breast cancer detection: Focus on the underserved. *Breast Cancer Res Treat* 1996;40:37-51.
45. Blustein J. Medicare coverage, supplemental insurance, and the use of mammography by older women. *N Engl J Med* 1995;332:1138-43.
46. Umberson D. Gender, marital status and the social control of health behavior. *Soc Sci Med* 1992;34:907-17.
47. Lavrakas PJ. *Telephone Survey Methods*. 2nd ed. Newbury Park, CA: Sage.
48. Zapka JG, Bigelow C, Hurley T, Ford LD, Egelhofer J, Cloud WM, et al. Mammography use among socio-demographically diverse women: The accuracy of self-report. *Am J Public Health* 1996;86:1016-21.
49. McGovern PG, Lurie N, Margolis KL, Slater JS. Accuracy of self-report of mammography and Pap smear in a low-income urban population. *Am J Prev Med* 1998;14(3):201-8.
50. Survey Sampling Institute Inc. 1995 report. Connecticut, USA.
51. Dean K, and Salem N. Detecting measurement confounding in epidemiological research: construct validity in scaling risk behaviors based on a population sample in Minnesota, USA. *J Epidemiol Community Health* 1998;52:195-9.

Table 1 Frequency distribution of study variables by gender and age.

Variable Name	Total	Gender		Age				
		Male	Female	18-24	25-39	40-54	55+	
<i>Socioeconomic factors</i>								
Race†§								
1. White	2998 (74%)	1323 (77%)	1,675 (73%)	255 (62%)	1068 (70%)	793 (75%)	882 (83%)	
2. Non-white	1054 (26%)	405 (23%)	649 (28%)	154 (38%)	455 (30%)	265 (25%)	180 (17%)	
Education†§								
1. Up to High school	1760 (43%)	698 (40%)	1062 (46%)	200 (49%)	562 (37%)	382 (36%)	616 (58%)	
2. Technical school or some college	926 (23%)	381 (22%)	545 (23%)	142 (35%)	359 (24%)	245 (23%)	180 (17%)	
3. College	797 (20%)	352 (20%)	445 (19%)	54 (13%)	388 (25%)	215 (20%)	140 (13%)	
4. Graduate school	569 (14%)	297 (17%)	272 (12%)	13 (3%)	214 (14%)	216 (20%)	126 (12%)	
Household income†§								
1. < 10,000	197 (5%)	50 (3%)	147 (6%)	38 (9%)	37 (2%)	23 (2%)	99 (9%)	
2. 10,000-14,999	194 (5%)	64 (4%)	130 (6%)	27 (7%)	58 (4%)	19 (2%)	90 (8%)	
3. 15,000-19,999	266 (7%)	98 (6%)	168 (7%)	57 (14%)	94 (6%)	40 (4%)	75 (7%)	
4. 20,000-24,999	440 (11%)	172 (10%)	268 (12%)	56 (13%)	162 (11%)	74 (7%)	148 (14%)	
5. 25,000-34,999	669 (17%)	271 (16%)	398 (17%)	52 (13%)	286 (19%)	172 (16%)	159 (15%)	
6. 35,000-49,999	786 (19%)	382 (22%)	404 (17%)	45 (11%)	378 (25%)	231 (22%)	132 (12%)	
7. ≥50,000	814 (20%)	387 (22%)	427 (18%)	61 (15%)	288 (19%)	307 (29%)	158 (15%)	
8. Missing	686 (17%)	304 (18%)	382 (16%)	73 (18%)	220 (14%)	192 (18%)	201 (19%)	
Employment status†§								
1. Employed	2775 (68%)	1310 (76%)	1465 (63%)	263 (64%)	1306 (86%)	895 (85%)	311 (29%)	
2. Unemployed	647 (16%)	146 (8%)	501 (22%)	145 (35%)	215 (14%)	150 (14%)	137 (13%)	
3. Retired	630 (16%)	272 (16%)	358 (15%)	1 (0.2%)	2 (0.1%)	13 (1%)	614 (58%)	

Table 1 (Continued) Frequency distribution of study variables by gender and age.

Variable Name	Total	Gender		Age				
		Male	Female	18-24	25-39	40-54	55+	
<i>Intrapersonal factors</i>								
Having high blood cholesterol§	743 (18%)	308 (18%)	435 (19%)	16 (4%)	146 (10%)	241 (23%)	340 (32%)	
Having high blood pressure§	825 (20%)	337 (20%)	488 (21%)	32 (8%)	142 (9%)	228 (22%)	423 (40%)	
Having diabetes§	201 (5%)	76 (4%)	125 (5%)	186 (4.8%)	6 (1%)	27 (2%)	103 (10%)	
Having hysterectomy§	416 (18%)	N/A	416 (18%)	1 (0.5%)	22 (3%)	136 (23%)	257 (41%)	
Having breast problem/cancer§	179 (8%)	N/A	179 (8%)	3 (1%)	68 (8%)	49 (8%)	59 (9%)	
Obesity§	940 (23%)	410 (24%)	530 (23%)	51 (12%)	305 (20%)	284 (27%)	300 (28%)	
<i>Interpersonal factors</i>								
Marital status†§								
1. Never been married	852 (21%)	406 (24%)	446 (17%)	327 (80%)	397 (26%)	82 (8%)	46 (4%)	
2. Married or living together	2223 (55%)	1036 (60%)	1187 (51%)	72 (18%)	881 (58%)	697 (66%)	573 (54%)	
3. Separated/divorced/widowed	977 (24%)	286 (17%)	691 (30%)	10 (2%)	245 (16%)	279 (26%)	443 (42%)	
Size of household (number of adults aged 18 or older)†§								
1. 1	1316 (32%)	485 (28%)	831 (36%)	87 (21%)	450 (30%)	300 (28%)	479 (45%)	
2. 2	2091 (52%)	937 (54%)	1154 (50%)	154 (38%)	929 (61%)	542 (51%)	466 (44%)	
3. ≥ 3	645 (16%)	306 (18%)	339 (15%)	168 (41%)	144 (9%)	216 (20%)	117 (11%)	
<i>Structural factor</i>								
Source of routine checkup§								
1. Family / general	2339 (58%)	1259 (73%)	1080 (46%)	269 (66%)	867 (57%)	574 (54%)	629 (59%)	
2. Internist	560 (14%)	239 (14%)	321 (14%)	14 (4%)	140 (9%)	173 (16%)	233 (22%)	
3. Others	518 (13%)	230 (13%)	288 (13%)	49 (12%)	184 (12%)	129 (12%)	156 (15%)	
4. OB/GYN (%female)	635 (27%)	N/A	635 (27%)	77 (36%)	332 (38%)	182 (30%)	44 (7%)	

† Significant gender differences (χ^2 test $p < 0.01$).§ Significant age differences (χ^2 test $p < 0.01$).

Table 2 Multiple logistic regression[§]: Significant determinants of each behavioral cluster by gender-age groups.

Behavioral cluster Gender-age group	n/N *(%)	Significant determinants	Odds ratio	95% C.I.	p
Medical checkup, Cholesterol test					
Male 18-24	41/192 (21.4%)	Two adults in the household	4.43	1.22 ~ 16.1	0.024
Male 25-39	213/644 (33.1%)	Some college or technical school	1.62	1.02 ~ 2.58	0.042
		Having high cholesterol	2.22	1.28 ~ 3.70	0.004
		Having high blood pressure	2.17	1.25 ~ 3.85	0.006
		Married	1.90	1.07 ~ 3.41	0.023
Male 40-54	228/459 (49.7%)	Non-white	2.04	1.25 ~ 3.34	0.004
		Having high blood pressure	1.85	1.14 ~ 3.03	0.014
Male 55+	313/433 (72.4%)	Having high cholesterol	1.75	1.04 ~ 2.94	0.035
		Having diabetes	2.41	1.25 ~ 9.09	0.017
		Internists for routine visits	1.89	1.02 ~ 3.52	0.044
Female 55+	481/629 (76.5%)	Having high cholesterol	4.76	2.86 ~ 8.33	0.0001
		Having high blood pressure	1.67	1.08 ~ 2.63	0.022
		Having diabetes	3.33	1.20 ~ 9.09	0.020
		OB/GYN for routine visits	0.40	0.19 ~ 0.84	0.016
Pap smear, Clinical breast examination, Medical checkup					
Female 18-24	136/217 (62.7%)	Income 25,000-34,999	0.18	0.04 ~ 0.78	0.022
		Income 35,000-49,999	0.14	0.03 ~ 0.70	0.017
		Income ≥ 50,000	0.21	0.05 ~ 0.82	0.025
		Income missing	0.24	0.07 ~ 0.88	0.032
		Having high blood pressure	5.56	1.25 ~ 25.0	0.024
		Internists for routine visits	7.00	2.27 ~ 21.4	0.001
		OB/GYN for routine visits	4.09	1.89 ~ 8.87	0.001
Female 25-39	603/879 (68.6%)	Non-white	2.09	1.47 ~ 2.98	0.0001
		OB/GYN for routine visits	1.63	1.16 ~ 2.29	0.005
Female 40-54	408/599 (68.1%)	(No significant predictors)			
Cholesterol test, Mammogram					
Female 40-54	264/599 (44.1%)	Non-white	1.61	1.06 ~ 2.44	0.027
		Not employed	0.64	0.41 ~ 0.99	0.046
		Having high cholesterol	1.96	1.27 ~ 2.94	0.002
Pap smear, Clinical breast examination, Mammogram					
Female 55+	295/629 (46.9%)	Income 35,000-49,999	3.65	1.58 ~ 8.39	0.002
		Income missing	2.34	1.19 ~ 4.62	0.014
		Having high cholesterol	1.37	1.14 ~ 2.33	0.008
		Having breast problems/cancer	2.44	1.33 ~ 4.35	0.004

* n=Number of respondents receiving all checking and/or screening in a behavioral cluster within the past 12 months; N=Total number of respondents in the gender-age group.

§ Logistic regression controlled for race, education, household income, employment status, disease history, obesity, marital status, size of household, and source of routine checkups. Each category was compared to the first category in the variable described in Table 1; having a disease or problem was compared to not having a disease or problem.

95% C.I. = The 95% confidence interval of the odds ratio. OB/GYN = Obstetrician/Gynecologist.

Table 3 Bivariate associations*: Factors significantly associated with Pap smear, mammography, and clinical breast examination among age 55 and older females.

Significant factor	Odds ratio	95% C.I.	p
Socioeconomic factor			
Income < 10,000	0.49	0.29 ~ 0.82	0.007
Income 25,000-34,999	0.55	0.35 ~ 0.85	0.008
Income 35,000-49,999	2.68	1.52 ~ 4.73	0.001
Income missing	1.50	1.00 ~ 2.25	0.049
High school or less education	0.69	0.50 ~ 0.95	0.023
Employed	1.47	1.03 ~ 2.11	0.036
Intrapersonal factor			
Having high cholesterol	1.61	1.15 ~ 2.22	0.005
Having breast problems/cancer	2.22	1.27 ~ 3.85	0.006
Interpersonal factor			
Married	1.75	1.27 ~ 2.41	0.001
Separated/Divorced/Widowed	0.59	0.43 ~ 0.81	0.001
One adult in the household	0.63	0.46 ~ 0.86	0.004
Two adult in the household	1.82	1.31 ~ 2.52	0.0003
Structural factor			
OB/GYN for routine visits	2.08	1.10 ~ 3.94	0.024

* Comparisons were made between having the factor and not having the factor. For example, women having household income less than \$10,000 were 0.49 times as likely as those whose income are equal or higher than \$10,000 to receive three women's cancer screening.

95% C.I. = The 95% confidence interval of the odds ratio. OB/GYN = Obstetrician/Gynecologist.

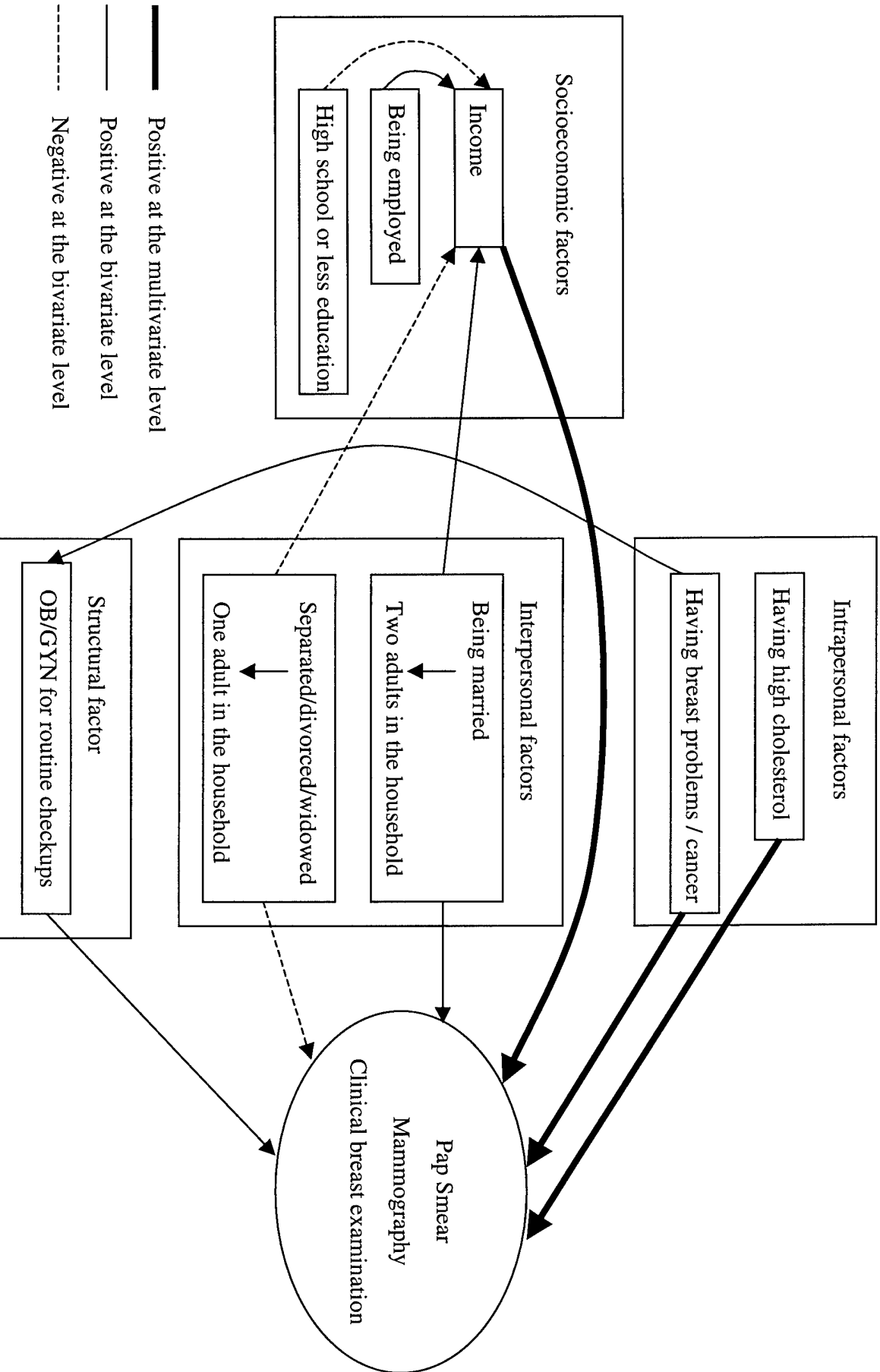

Figure 2 Significant relationships among behavioral determinants and between behavioral determinants and the cluster of cancer screening behaviors in females age 55 and older.

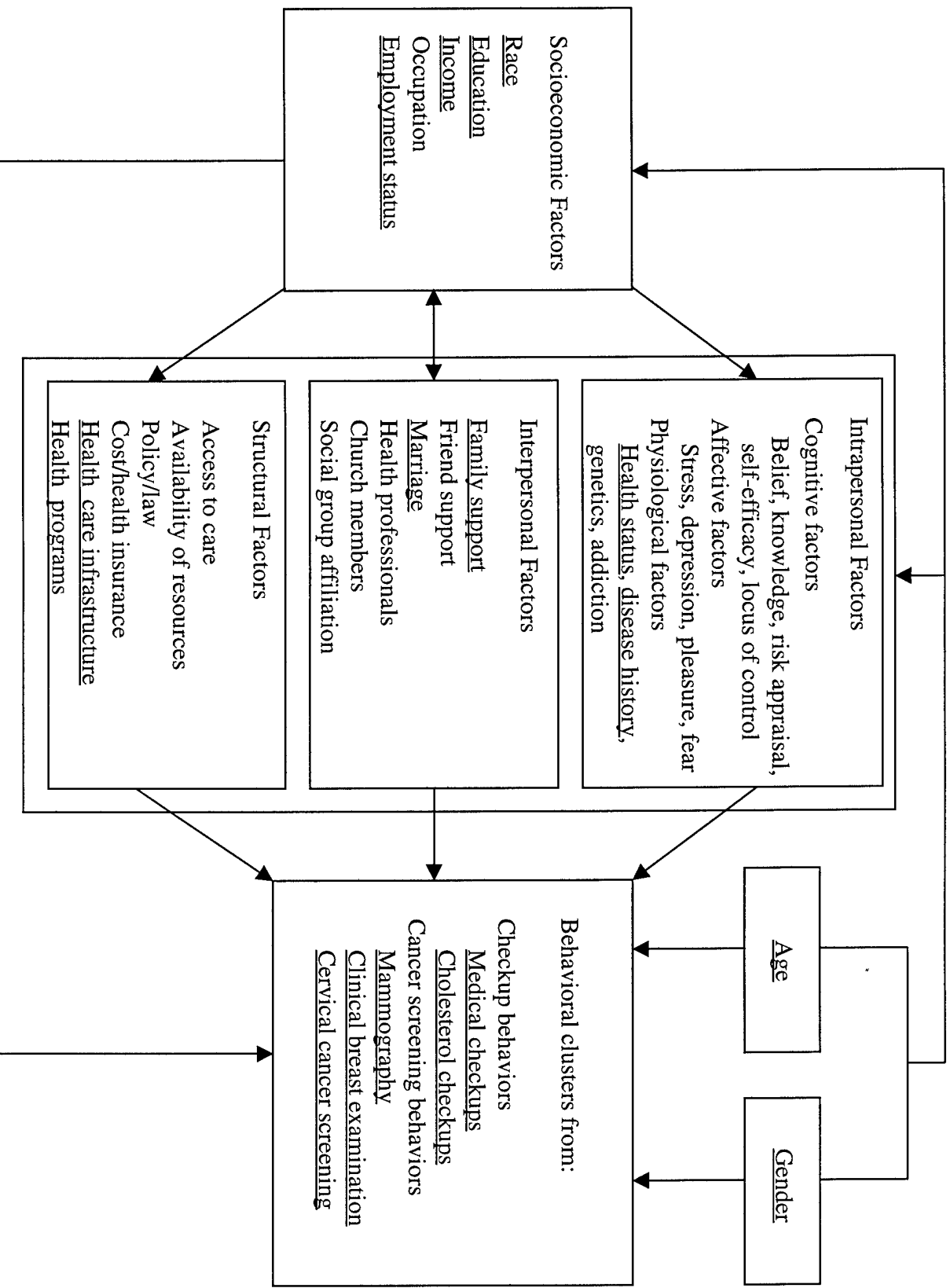

Figure 1 Conceptual framework for predicting groups of checkup and screening behaviors.

Note: Variables with underlines are examined in this study.

APPENDIX 2
Outline of Cost-Effectiveness of BRCA1/2 Counseling and Testing Manuscript

**COST-EFFECTIVENESS OF GENETIC COUNSELING AND TESTING FOR BRCA1
AND BRCA2 BREAST CANCER SUSCEPTIBILITY MUTATIONS FOR HIGH-RISK
WOMEN WITH AND WITHOUT BREAST CANCER**

INTRODUCTION

Recent advances in molecular genetics have led to the isolation of the BRCA1 and BRCA2 breast cancer susceptibility genes (Miki, 1994; Wooster, 1995). Mutations in these genes may account for up to 10% of cases of breast cancer (Claus, 1996), and are observed in a significant proportion of families with multiple cases of breast and ovarian cancer (Frank, 1998). Women who carry a BRCA1 or BRCA2 mutation have an estimated 55% to 85% lifetime risk of breast cancer, and a 15% to 60% risk of ovarian cancer (Easton, 1995; Ford, 1998; Ford, 1994). Testing for mutations in these two genes is now available commercially, and is starting to be used in clinical practice (Cho, 1999). Some insurers now cover part or all of the cost of counseling and testing for breast cancer genetic susceptibility in high-risk women (Atlantic Information Services, 1998).

Information obtained from genetic testing may enable women to make more informed decisions about their medical management. Women who test positive for a BRCA1 or BRCA2 mutation have several options for cancer screening and cancer risk reduction, although long-term studies demonstrating the efficacy of these strategies in mutation carriers are not yet available. Women could choose intensive surveillance, initiated at an early age, to maximize the chances of detecting a cancer early (Burke, 1997). Based on recent clinical trial data, tamoxifen (Fisher, 1998) or raloxifene (Cummings, 1999) may be a consideration for breast cancer chemoprophylaxis, although data about the effects of these drugs in mutation carriers are not yet available. Women with a mutation may also opt to have a prophylactic mastectomy (Hartmann, 1999) and/or oophorectomy, to decrease the risk of breast and ovarian cancer, respectively. Several decision analyses (Schrag, 1997; Grann 1997) have suggested that a prophylactic

mastectomy may prolong life approximately 3 to 4 years for a 30 year old woman with a BRCA1 susceptibility mutation.

While BRCA1 and BRCA2 susceptibility testing are accepted as a research tool, clinical trials have yet to be performed to test whether genetic counseling and testing reduce morbidity or mortality from breast and ovarian cancer in high risk women. In this study, we use decision analytic methods to estimate the costs and outcomes of such counseling and testing based upon available data. The simulation model created in this study is used to examine the cost-effectiveness of BRCA1/2 genetic counseling and testing in women who are at high risk of carrying a mutation.

METHODS

We created a computer simulation model to calculate the costs and outcomes of offering genetic counseling and BRCA1/2 testing to women at risk of carrying a susceptibility mutation in one of these genes, compared to offering counseling only, and to routine medical care. The model was programmed using the Visual C++ programming language (Microsoft, Inc., Redmond, WA).

The model is used for a cost-utility analysis, with the results presented in incremental cost-effectiveness ratios, with costs expressed in dollars and effects expressed as quality-adjusted life years (QALYs). We take a societal perspective in this analysis.

The simulation model uses a Monte Carlo stochastic simulation technique (Doubilet, et al., 1985) to test the cost-effectiveness of providing counseling and testing for longitudinal cohorts of women. This simulation technique allows us not only to calculate point estimates for costs and effects, but also to calculate confidence intervals for these outcomes incorporating the

uncertainty in our parameter estimates. For each counseling and testing alternative, 100,000 individuals were simulated; and the costs and outcomes averaged across the simulated cohorts.

Model Structure

The decision tree diagram representing the initial counseling and testing decision is shown in Figure 1. A simulated cohort of women undergo each counseling and testing alternative: counseling and testing, counseling only, and routine medical care (no counseling or testing). Each woman in the cohort may carry a BRCA1 or BRCA2 susceptibility mutation, with a probability equal to the prevalence of the mutations in the cohort. For those women undergoing counseling and testing, the test result may be positive for a BRCA1 susceptibility mutation, positive for a BRCA2 mutation, or negative for a susceptibility mutation. We assume for our baseline analysis that full gene sequencing of both the BRCA1 and BRCA2 genes is performed. We also assume that women will not have both mutations simultaneously. Indeterminate results from full sequencing are considered to be negative in our baseline analysis. The test result may be a true positive, true negative, false positive, or false negative test based upon whether or not the woman is carrying a mutation, and the sensitivity and specificity of the gene tests.

If a woman tests positive for a BRCA1 or BRCA2 mutation, then prophylactic and surveillance options shown in Figure 1 are chosen. The probability of choosing a particular option is based upon the choices of a cohort of women who have tested positive for a BRCA1/2 mutation (Lerman, XXX ref). At the time of data collection, breast cancer chemoprophylaxis with tamoxifen or raloxifene was not a widely available item, so we assumed that XX% of the

current cohort would choose chemoprophylaxis upon testing positive if this option were available. This assumption was subjected to sensitivity analysis.

[XXX Need something on distribution of other therapies here.]

The prophylactic options chosen affect the probability of developing breast or ovarian cancer; screening options affect the probability of detecting disease once it has developed. Disease development was modeled using a disease initiation Markov model (Beck and Pauker, 19XX). Figure 2 shows the longitudinal model of disease development. In this model, the probability of developing breast and/or ovarian cancer in any particular year is a function of the simulated woman's age and BRCA1/2 gene status; this probability is further modified by any prophylactic procedures chosen. This model also accounts for competing (non-cancer) mortality. We assumed that the probability for developing ovarian cancer was independent of the development of breast cancer, and vice-versa, due to lack of evidence to the contrary. We also assume that all ovarian cancer starts as localized disease; breast cancer can start either as localized invasive disease, or can start as ductal carcinoma in situ (DCIS) and potential progress to invasive disease.

Once a cancer develops, the disease may be detected either due to screening or due to clinical surfacing. If either cancer is not detected in a particular year, then the disease has a probability of progression to a more advanced stage. Once a cancer is detected, the disease is treated (XXX Fig 3?), which incurs a cost of treatment, and a loss in quality of life due to being diagnosed and with cancer. A woman treated for cancer has a chance of having the cancer recur at the same stage or progressing to a more advanced stage, and a chance of dying of the cancer if she has distant spread of the cancer. If a woman is diagnosed and treated for breast or ovarian

cancer, she also retains a chance of dying of a non-cancer cause, or of developing the other cancer.

Model Probabilities

For this cost-effectiveness simulation model, we modeled the occurrence of events of interest (e.g. development of breast cancer), and the costs and quality of life associated with these occurrences. In order to determine the probabilities of these events occurring in the simulated cohort of women, a MEDLINE search was conducted to determine parameters from the published literature, when possible.

[CARE parameters]

[progression of undetected disease]

Model Costs

The cost of providing counseling is based upon a time-motion study of counselors and patients in the Lombardi Cancer Center Cancer Genetics Program (Lawrence, 1999). The cost of testing for the baseline analysis is based upon the estimated cost to provide full gene sequencing of the BRCA1 and BRCA2 genes (Lawrence, 1999).

The cost of diagnosis and treatment of breast and ovarian cancer were derived from Surveillance, Epidemiology, and End-Results (SEER)- Medicare linked data, which links Medicare expenditure data to individuals in the SEER registry. From these data sets, we were able to obtain aggregate data on cost of cancer care by age, stage at diagnosis, and treatment phase. Treatment phase includes: 1) prediagnostic phase (XXX def), 2) Initial phase (XXX), 3)

continuing care phase (XXX), and terminal phase (XXX). Breast cancer SEER-Medicare data were provided by J. Warren (personal communication), and ovarian cancer data were provided by R. Etzioni (personal communication).

Model Utilities

Utilities for relevant health states were obtained by telephone survey of XXX women at high risk for having a BRCA mutation who were participating in the CARE program. Utilities are measures of preference for a state of health that allow an individual to place a valuation on the quality of life associated with a state of health. Utilities were obtained using a linear rating scale (LRS) assessment technique (Froberg and Kane, 1989) for the relevant breast and ovarian cancer outcomes. The average LRS for current health of those women without a history of breast or ovarian cancer was used to represent the utility of not having cancer in the model. These utilities were used as quality-adjustment weights with which to calculate outcomes in units of dollars per quality-adjusted life year.

Sensitivity Analyses

Sensitivity analyses, or varying a parameter over a range to determine the impact on the outcome was conducted for all variables. These analyses allow us to examine changes in the assumptions about the values of individual parameters. We report the analyses that had the largest impacts on model results.

RESULTS

Model Parameters

The parameters used in the model, as well as their 95% confidence interval, are shown in Table 1.

[Costs]

[Utilities]

Cost-Effectiveness of Counseling and Testing

[Women without cancer]

[Women with breast cancer]

Sensitivity Analyses

DISCUSSION

[Discussion of CE of counseling and testing]

[Comparison of cost-effectiveness to that of current funded programs]

[Comparison to other Decision and cost-effectiveness analyses (Schrag, Grann)]

[Sensitivity analyses – how robust is conclusion, and what areas for future research do these analyses point to]

[Strengths and limitations of study]

[Conclusion – Test or no, and if yes, then who do we test?]

APPENDIX 3
Quality of Life Library - Sample Data Abstraction Forms

FACIT-Functional Assessment of Chronic Illness Therapy (FACIT) Scales

Measure: Functional Assessment of Chronic Illness Therapy (FACIT) Scales; formerly Functional Assessment of Cancer Therapy (FACT) Scales

Contact Person: David Cella, PhD

Center on Outcomes, Research, and Education (CORE)
Evanston Northwestern Healthcare
1000 Central Suite, Suite 101
Evanston, IL 60201

Phone Number: (847) 570-1730

Fax Number: (847) 570-1735

Email: d-cella@nwu.edu

For permission of usage, subscales, manuals, and manuscripts contact:

Kimberly A Webster, M.A.
Director of Communications
Evanston Northwestern Healthcare
1000 Central Street, Suite 101
Evanston, IL 60201
Phone Number:(847) 570-1731
Fax Number: (847) 570-1735
email: k-webster@nwu.edu

Terms of Use: No charge to investigators willing to share applicable results, especially those results which further reliability and validity testing. Prior to including FACIT in a project, a *Project Information Form* must be completed. The new FACT manual and information on individual subscales may be purchased.

General or Disease Specific: The general form of the fact, FACT-G (27 items) can be further divided into cancer specific subscales:

		<u>Number of Items</u>
FACT-B-	For patients with Breast Cancer	9 + 27-->36
FACT-BI-	For patients with Bladder Cancer	12+27-->39
FACT-Br-	For patients with solid Brain Tumor	19+27-->46
FACT-C-	For patients with Colorectal Cancer	9+27--->36
FACT-CNS	For patients with cancer in the Central Nervous System	12+27-->39
FACT-Cx-	For patients with Cancer of the Cervix	15+27-->42
FACT-E	For patients with Esophageal cancer	17+27-->44
FACT-H&N-	For patients with Head and Neck cancer	11+27-->38
FACT-L-	For patients with Lung cancer	9 + 27-->36
FACT-O-	For patients with Ovarian cancer	12+27-->39
FACT-P-	For patients with Prostate cancer	12+27-->39
FACT-Pa	For patients with Pancreatic cancer	9+27--->36

Treatment specific subscales:

FACT-BMT- For patients undergoing Bone Marrow Transplant 23+27--->50

FACT-CRA-	Modifiers and/or retinoid treatment	17+27--->44
FACT-ES-	For patients with Endocrine Symptoms	18+27--->45
FACT-NTX-	For patients with Neurotoxicity from systemic chemotherapy	11+27-->38
FACT-Taxane-	For patients with Taxane toxicity	16+27-->43

Symptom specific subscales:

FAACT-	Functional Assessment of Anorexia/Cachexia Treatment	18+27-->45
FACT-An-	For patients with anemia and/or fatigue	20
FACIT-F-	FACIT-Fatigue and the stand alone Fatigue Scale	13+27-->50
FAIT-F-	Functional Assessment of Incontinence Therapy- Fecal	12+27-->39
FAIT-U-	Functional Assessment of Incontinence Therapy-Urinary	11+27-->39

Non-cancer specific scales:

FACIT-Sp-	FACIT-Spiritual Well-Being	12+27-->39
FACIT-Pal-	FACIT-Palliative Care	19+27-->46
FAHI-	For patients with HIV Infection	47 total (44 scored)
FAMS-	Functional Assessment of Multiple Sclerosis	59 total (44 scored)
FANLT-	Functional Assessment of Non-Life Threatening conditions	26 total

Domains for FACT-G (Version 4):

- Physical Functioning (7 items)
- Social Well Being (7 items)
- Emotional Well Being (6 items)
- Functional Well Being (7 items)

Administration Time: 5 minutes for the FACT-G and varying time between 5-10 minutes for other scales most of which include the FACT-G

Mode of Administration: It is designed for patient self-administration but it may also be administered in an interview.

Time Frame: Past 7 days

Scoring: 0-4 scale with 0 representing a response of "not at all" and 4 representing a response of "very much." Maximum possible score on the FACT-G is 108 with a higher score indicating a high QoL.

Preference Based: No.

Population used in:

- Metastatic Prostate Cancer Among Men of Lower Socioeconomic Status¹
- Spanish FACT including use on people with low literacy skills.²
- Women and men with physical disabilities and cancer, and women with traumatic and women with chronic physical conditions.³
- In a rural sample.⁴
- After prostatectomy or radiation therapy.⁵
- Long term survivors of Cancer.⁶

Reliability and Validity: (Version 2)

FACT-G

	Test/Retest Reliability	Internal Consistency (α)	Spanish Fact-Internal Consistency (α)
Physical Well Being	.88	.82	.82
Functional Well Being	.84	.69	.83
Social Well Being	.82	.74	.74
Emotional Well Being	.82	.80	.66
Relationship with Doctor	.83	.65	.75
Total Score	.92	.89	.89

Note: Relationship with Doctor does not appear in version 4
Sensitivity to change studies have also been conducted

Validity:

w/ Functional Living Index-Cancer	r=.80
w/Quality of Life Index	r=.74
w/Taylor Manifest Anxiety Scale	r=.57
w/Brief Profile of Mood States	r=.69
w/Eastern Cooperative Oncology Group	r=.56

Comments:

-The FACT-G has been translated into 30 languages. Specific subscales have also been translated into other languages.

-Complete information on FACIT can be found at [http:// www.facit.org](http://www.facit.org)

-Changes from version 3 to version 4 of the FACIT include:

- dropping the Relationship with Doctor Subscale. This subscale was associated with ceiling effects.
- subscale weighted items are exclusion.
- item rewording.
- item numbering
- scoring

-FACIT is written at a sixth grade reading level.

References:

Cella DF, Hernandez L, Bonomi AE, et al. Spanish Language Translation and Initial

Validation of the Functional Assessment of Cancer Therapy Quality-of-Life Instrument. *Med Care* 1998; 36(9): 1407-1418.

Cella DF, Tulsky DS; Gray G, et al. The Functional Assessment of Cancer Therapy Scale: Development and Validation of the General Measure. *J Clin Oncol* 1993; 11(3): 570-579.

References on specific modules:

Brady MJ, Cella DF, Fei M, et al. Reliability and Validity of the Functional Assessment of Cancer Therapy-Breast Quality-of-Life Instrument. *J Clin Oncol* 1997; 15(3): 974-986.

Weitzner MA, Meyers CA, Gelke CK, et al. The Functional Assessment of Cancer Therapy (FACT) Scale: Development of a Brain Subscale and Revalidation of the General Version (FACT-G) in Patients with Primary Brain Tumors. *Cancer* 1995; 75(5): 1151-1161.

Cella DF, Bonomi AE, Lloyd SR, et al. Reliability and Validity of the Functional Assessment of Cancer Therapy-Lung (FACT-L) Quality of Life Instrument. *Lung Cancer* 1995; 12: 199-220.

McQuellon RP, Russell GB, Cella DF, et al. Quality of Life Measurement in Bone Marrow Transplantation: Development of the Functional Assessment of Cancer Therapy-Bone Marrow Transplant (FACT-BMT) Scale. *Bone Marrow Transplantation* 1997; 19: 357-368.

Cella DF, Bonomi AE. The Functional Assessment of Cancer Therapy (FACT) and Functional Assessment of HIV Infection (FAHI) Quality of Life Measurement System. *Quality of Life and Pharmacoeconomics in Clinical Trials*. 2nd edition. Philadelphia: Lippincott-Raven Publishers, 1996.

List MA, D'Antonio LL, Cella DF, et al. The Performance Status Scale for Head and Neck Cancer Patients and the Functional Assessment of Cancer Therapy-Head and Neck Status: A Study of Utility and Validity. *Cancer* 1996; 77: 2294-2301.

Yellen SB, Cella DF, Webster KA, et al. Measuring Fatigue and Other Anemia-Related Symptoms with the Functional Assessment of Cancer Therapy (FACT) Measurement System. *Jour Pain and Symptom Management* 1997; 13(2): 63-74.

Fish LS, Lewis BE. Quality of Life Issues in the Management of Ovarian Cancer. *Seminars in Oncology* 1999; 26(1): 32-39.

Esper P, Mo F, Chodak G, et al. Measuring Quality of Life in Men with Prostate Cancer Using the Functional Assessment of Cancer Therapy-Prostate Instrument. *Urology* 1997; 50(6): 920-928.

D'Antonio LL, Zimmerman GJ, Cella DF, et al. Quality of Life and Functional Status Measures in Patients with Head and Neck Cancer. *Arch of Otolaryngology* 1996; 122: 482-487.

Cella DF. The Functional Assessment of Cancer Therapy-Anemia (FACT-An) Scale: A New Tool for the Assessment of Outcomes in Cancer Anemia and Fatigue. *Seminars in Hematology* 1997; 34(3): 13-19.

Cella DF, Dineen K, Arnason B, et al. Validation of the Functional Assessment of Multiple Sclerosis Quality of Life Instrument. *Neurology* 1996; 47: 129-139.

1 **Knight SJ, Chmiel JS, Kuzel T, Sharp L.** Quality of Life in Metastatic Prostate Cancer Among Men of Lower Socioeconomic Status: Feasibility and Criterion Related Validity of 3 Measures. *J Urol* 1998 Nov; 160(5):1765-9.

2 **Cella DF, Hernandez L, Bonomi AE, et al.** Spanish Language Translation and Initial Validation of the Functional Assessment of Cancer Therapy Quality-of-Life Instrument. *Med Care* 1998; 36(9): 1407-1418.

3 **Tate DG, Riley BB, Perna R; Roller S.** Quality of Life Issues Among Women with Physical Disabilities or Breast Cancer. *Arch Phys Med Rehabil* 1997 Dec; 78(12 Suppl 5):S18-25.

4 **Winstead-Fry P, Schultz A.** Psychometric Analysis of the Functional Assessment of Cancer

Therapy-General (FACT-G) Scale in a Rural Sample. *Cancer* 1997 Jun 15;79(12):2446-52

5 Shrader-Bogen CL, Kjellberg JL, McPherson CP, Murray CL. Quality of Life and Treatment Outcomes: Prostate Carcinoma Patients' Perspectives After Prostatectomy or Radiation Therapy. *Cancer* 1997 May 15;79(10):1977-86

6 Dow KH, Ferrell BR, Leigh S, Ly J, Gulasekaram P. An Evaluation of the Quality of Life Among Long-Term Survivors of Breast Cancer. *Breast Cancer Res Treat* 1996;39(3):261-73.

European Organization for Research and Treatment of Cancer Quality of Life Questionnaire Core 30 Items (QLQ-C30) + Supplemental Specific Modules

Measure: EORTC-QLQ-C30 + specific modules

Contact Person: EORTC Data Center
Quality of Life Unit
Ave.E.Mounier 83, Bte 11
B - 1200 Brussels
Belgium
Phone Number: 31-20-512-2481
Fax Number:: Belgium-(2)-7723545

Terms of Use: Written consent prior to use is required. If the instrument is used in a university-based investigation, it is free. Other uses are subject to royalty fees.

Disease Specific or General: EORTC-QLQ-C30 is cancer general but is designed to be used with a supplementary specific module (many modules are still under development).

QLQ-BR23-breast cancer module (23)
QLQ-LC13- lung cancer module (13)
QLQ-BN20- brain cancer module (20)
QLQ-CR38- colorectal cancer module (38)
QLQ-H&N35-head and neck cancer module (35)
QLQ-OE24-oesophageal cancer module (24)
QLQ-OV28-ovarian cancer module (28)
QLQ-S- survivors (45)
Bladder cancer module
Myeloma module
Pancreatic cancer module
Body Image module
High-dose Chemotherapy module
Leukemia module
Ophthalmic cancer module
Palliative care module
prostate cancer module

Domain: QLQ-C30 has 9 subscales.

6 functional scales: -physical
-role
-cognitive
-emotional
-social
-global QoL

3 symptom scales: -fatigue
-pain
-nausea and vomiting

+ single items assessing additional symptoms (dyspnea, sleep disturbance, constipation, diarrhea and financial impact).

Preference Based: No.

Mode of Administration: Self or interview administered.

Administration Time: 11 to 12 minutes for the QLQ-C30. No data available on the modules.

Time Frame: 7 questions are general time period questions, and 23 are “during the past week.”

Number of Items: 30 items in the QLQ-C30. The modules vary in length.

Scoring: Separate scores are calculated for the 9 subscales as well as the individual items. The scores can then be linearly transformed on a 0-100 scale with a higher score indicating higher QoL.

Reliability and Validity:

Reliability (from Aaronson et al.):

Internal Consistency:

	Before Treatment	After Treatment
Physical	.68	.71
Role	.54	.52
Cognitive	.56	.73
Emotional	.73	.80
Social	.68	.77
Global quality of life	.86	.89
Fatigue	.80	.85
Nausea and vomiting	.65	.73
Pain	.82	.76

Validity:

- inter-scale correlations: the strongest correlations occurred between the physical functioning, role functioning, and fatigue scales (.54 to .63). Considerable correlations were also found between the fatigue, emotional, and social functioning scales (>.40) . A weak correlation was found between the emotional functional scale and the physical and role functioning scales.

-Clinical Validity was also evaluated in terms of responsiveness to change in health status and known-group comparisons.

From McDowell et al.:

- the emotional functional scale correlated .71 with the Hospital Anxiety and Depression Scale.
- the physical functional scale correlated .73 with the Sickness Impact Scale, with a .58

correlation with the cognitive and fatigue scales, .55 with the role scale, and .48 with the emotional and social scales.

-with the CARES, there was a .71 correlation with the physical scales, a .56 with the emotional scales, .46 with the social scale, and .69 with the pain scale.

-the QLQ-C30 has also been compared with other instruments.

Population Used In:

- in patients with nonmetastatic breast carcinoma¹
- in gastric cancer patients²
- in patients with localized prostate cancer³
- for patients with multiple myeloma⁴
- in head and neck cancer patients⁵
- in Hodgkin's disease⁶
- in patients 70 and older with advanced non-small-cell lung cancer⁷
- in people with different age and gender⁸
- in patients with breast cancer^{9,10}
- in patients with esophageal cancer¹¹
- in patients with prostate cancer¹²
- in patients with brain cancer¹³
- in leukemia patients¹⁴
- in patients with malignant melanoma¹⁵
- in patients with lung cancer¹⁶
- in patients with ovarian cancer¹⁷
- in advanced colorectal cancer¹⁸

Comments:

-available in over 30 languages

-the weakest scale from a psychometric viewpoint was the role functioning scale.

It has been suggested that because it is a brief scale and limited to work and household activities, it should be expanded to a broader range of activities thus lending to a more variable range of responses.

-There are some reservations concerning the QLQ-C30s ability to discriminate between patients with different stages of disease though the manner in which this was determined may not be particularly useful predictor of current functioning levels (see Aaronson et al).

-The website <http://www.eortc.be/home/qol/> has information about the QLQ-C30 plus an order form to order a reference values manual and CD ROM.

References:

Aaronson NK, Ahmedzai S, Bergman B, et al. The European Organization for Research and Treatment of Cancer QLQ-C30: A Quality-of-Life Instrument for Use in International Clinical Trials in Oncology. *J of the National Cancer Institute* 1993; 85(5):55-65.

McDowell M, Newell B. The EORTC Quality of Life Questionnaire. In *Measuring Health: A Guide to Rating Scales and Questionnaires* (2nd edition). New York: Oxford University Press. 1996, pp 401-409.

Spranger MAG, Cull A, Groenvold M, et al. The European Organization for Research and Treatment of Cancer Approach to Developing Questionnaires Modules: An Update and Overview. *Quality of Life Research* 1998; 7(4): 291-300.

-
- ¹ **Macquart-Moulin G, Viens P, Genre D.** Concomitant chemoradiotherapy for patients with nonmetastatic breast carcinoma: side effects, quality of life, and organization. *Cancer* 1999 May 15;85(10):2190-9.
- ² **De Vita F, Orditura M, Auremma A, et al.** A pilot study of adjuvant chemotherapy with double modulation of 5-fluorouracil by methotrexate and leucovorin in gastric cancer patients. *Panminerva Med* 1999 Mar;41(1):35-8.
- ³ **Lilleby W, Fossa SD, Waehre HR, Olsen DR.** Long-term morbidity and quality of life in patients with localized prostate cancer undergoing definitive radiotherapy or radical prostatectomy. *Int J Radiat Oncol Biol Phys* 1999 Mar 1;43(4):735-43.
- ⁴ **Stead ML, Brown JM, Velikova G, et al.** Development of an EORTC questionnaire module to be used in health-related quality-of-life assessment for patients with multiple myeloma. European Organization for Research and Treatment of Cancer Study Group on Quality of Life. *Br J Haematol* 1999 Mar;104(3):605-11.
- ⁵ **Bjordal K, Hammerlid E, Ahlner-Elmqvist M, et al.** Quality of life in head and neck cancer patients: validation of the European Organization for Research and Treatment of Cancer Quality of Life Questionnaire-H&N35. *J Clin Oncol* 1999 Mar;17(3):1008-19.
- ⁶ **Flechtner H, Ruffer JU, Henry-Amar M, et al.** Quality of life assessment in Hodgkin's disease: a new comprehensive approach. First experiences from the EORTC/GELA and GHSG trials. EORTC Lymphoma Cooperative Group. Groupe D'Etude des Lymphomes de L'Adulte and German Hodgkin Study Group. *Ann Oncol* 1998;9 Suppl 5:S147-54.
- ⁷ Effects of vinorelbine on quality of life and survival of elderly patients with advanced non-small-cell lung cancer. The Elderly Lung Cancer Vinorelbine Italian Study Group. *J Natl Cancer Inst* 1999 Jan 6;91(1):66-72.
- ⁸ **Hjermstad MJ, Fayers PM, Bjordal K, Kaasa S.** Using reference data on quality of life--the importance of adjusting for age and gender, exemplified by the EORTC QLQ-C30 (+3). *Eur J Cancer* 1998 Aug;34(9):1381-9.
- ⁹ **McLachlan SA, Devins GM, Goodwin PJ.** Validation of the European Organization for Research and Treatment of Cancer Quality of Life Questionnaire (QLQ-C30) as a measure of psychosocial function in breast cancer patients. *Eur J Cancer* 1998 Mar;34(4):510-7.
- ¹⁰ **Sprangers MA, Groenvald M, Arraras JI, et al.** The European Organization for Research and Treatment of Cancer breast cancer-specific quality-of-life questionnaire module: first results from a three-country field study. *J Clin Oncol* 1996; 14:2756-68.
- ¹¹ **Blazeby JM, Alderson D, Winstone K, et al.** Development of an EORTC questionnaire module to be used in quality of life assessment for patients with oesophageal cancer. *Eur J Cancer* 1996; 32A:1912-7.
- ¹² **Borghede G, Sullivan M.** Measurement of quality of life in localized prostate cancer patients treated with radiotherapy. Development of a prostate cancer-specific module supplementing the EORTC QLQ-C30. *Qual Life Res* 1996;5:212-22.
- ¹³ **Osoba D, Aaronson NK, Muller M, et al.** The development and psychometric validation of brain cancer quality-of-life questionnaire for use in combination with general cancer-specific questionnaires. *Qual Life Res* 1996; 5:139-50.
- ¹⁴ **Watson M, Zittoun R, Hall E, et al.** A modular questionnaire for the assessment of longterm quality of life in leukaemia patients: the MRC/EORTC QLQ-LEU. *Qual Life Res* 1996; 5:15-9.
- ¹⁵ **Sigurdardottir V, Bolund C, Sullivan M.** Quality of life evaluation by the EORTC questionnaire technique in patients with generalized malignant melanoma on chemotherapy. *Acta Oncol* 1996; 35: 149-58.

¹⁶ **Bergman B, Aaronson NK, Ahmedzai S, et al.** The EORTC QLQ-LC13: a modular supplement to the EORTC Core Quality of Life Questionnaire (QLQ-C30) for use in lung cancer clinical trials. *Eur J Cancer* 1994; 30A: 635-42.

¹⁷ **Montazeri A; McEwen J; Gillis CR.** Quality of life in patients with ovarian cancer: current state of research. *Support Care Cancer* 1996 May;4(3):169-79.

¹⁸ **Hill M; Norman A; Cunningham D, et al.** Impact of protracted venous infusion fluorouracil with or without interferon alfa-2b on tumor response, survival, and quality of life in advanced colorectal cancer. *J Clin Oncol* 1995 Sep;13(9):2317-23.

Quality-Adjusted Time Without Symptoms of disease and Toxicity of treatment

Measure: Q-TWiST

Contact Person: Richard D. Gelber
Department of Pediatrics (Biostatistic)
Harvard Medical School of Public Health
and Dana-Farber Cancer Institute
44 Binney Street
Boston, Massachusetts 02115
email: gelber@hsph.harvard.edu

Terms of Use: N/A

General or Disease Specific: Cancer and AIDS General

Number of Items: N/A

Domain: Utility Instrument that makes comparisons in quality and quantity of life.

Administration Time: N/A

Mode of Administration: N/A

Time Frame: General

Scoring: (from Gelber et al.) "A weight of 0 indicates the period of time is as bad as death, and a weight of 1 indicates perfect health. Weights between 0 and 1 indicate degrees between these extremes. . .The Q-TWiST end point is obtained by adding the weighted periods of time (74)."

Preference Based: Yes.

Population Used In:

- in patients with metastatic prostate cancer¹
- in advanced prostate cancer²
- in patients undergoing treatment with Interferon³
- adjuvant therapy of patients with melanoma⁴
- adjuvant chemotherapy for breast cancer⁵⁶
- in patients with node-positive breast cancer⁷
- in operable breast cancer⁸
- in patients undergoing adjuvant radiation therapy and chemotherapy for resectable rectal cancer⁹
- in postmenopausal breast cancer¹⁰
- in patients with stage III colon cancer¹¹
- in small cell lung cancer¹²

Reliability and Validity: N/A

Comments:

- The Q-TWiST "is a statistical methodology designed to facilitate treatment comparisons highlighting quality-of-life oriented tradeoffs (Gelber in an email)."
- Can compare treatments in terms of QoL outcomes and in terms of survival.
- Formulas provided in Gelber et al, 1996.
- One of the biggest advantages that Q-TWiST has is that the results can be presented as threshold analysis in graphs or table of the weights of two treatments.
- The main disadvantage of Q-TWiST is that weights are assigned to a small number of discrete states.

References:

Gelber RD, Goldhirsch A, Cole BF. Evaluation of effectiveness: Q-TWiST. *Cancer Treatment Reviews* 1993; 19 (supp A): 73-84.

Gelber RD, Cole BF, Gelber S, Goldhirsch A. Quality of Life in Pharmacoeconomics in Clinical Trials (2nd edition). **Spilker B**, ed.. Philadelphia: Lippincott-Raven Publishers. 1996, pp.437-444.

Spilker B, ed. Quality of Life in Pharmacoeconomics in Clinical Trials (2nd edition). Philadelphia: Lippincott-Raven Publishers. 1996, pp.409-410.

- 1 **Rosendahl I, Kiebert GM, Curran D, et al.** Quality-adjusted survival (Q-TWiST) analysis of EORTC trial 30853: comparing goserelin acetate and flutamide with bilateral orchiectomy in patients with metastatic prostate cancer. *Prostate* 1999 Feb 1;38(2):100-9.
- 2 **Pummer K, Lehnert M, Stettner H, Hubner G.** Randomized comparison of total androgen blockade alone versus combined with weekly epirubicin in advanced prostate cancer. *Eur Urol* 1997;32 Suppl 3:81-5.
- 3 **Longo DL.** Interferon toxicity worse in retrospect; impact on Q-TWiST? Quality-Adjusted Time Without Symptoms or Toxicity. *J Clin Oncol* 1998 Nov;16(11):3716; discussion 3718.
- 4 **Agarwala SS, Kirkwood JM.** Adjuvant interferon treatment for melanoma. *Hematol Oncol Clin North Am* 1998 Aug;12(4):823-33.
- 5 **Glasziou PP, Cole BF, Gelber RD, et al.** Quality adjusted survival analysis with repeated quality of life measures. *Stat Med* 1998 Jun 15;17(11):1215-29.
- 6 **Bryson HM, Plosker GL.** Tamoxifen: a review of pharmacoeconomic and quality-of-life considerations for its use as adjuvant therapy in women with breast cancer. *Pharmacoeconomics* 1993 Jul;4(1):40-66.
- 7 **Trippoli S, Becagli P, Messori A.** Adjuvant cyclophosphamide, methotrexate and fluorouracil for node-positive breast cancer: a lifetime cost-utility analysis based on a modified Q-TWiST method [letter]. *Eur J Clin Pharmacol* 1997;53(3-4):281-2.
- 8 **Gelber RD, Goldhirsch A, Cavalli F.** Quality-of-life-adjusted evaluation of adjuvant therapies for operable breast cancer. The International Breast Cancer Study Group. *Ann Intern Med* 1991 Apr 15;114(8):621-8.
- 9 **Gelber RD, Goldhirsch A, Cole BF, et al.** A quality-adjusted time without symptoms or toxicity (Q-TWiST) analysis of adjuvant radiation therapy and chemotherapy for resectable rectal cancer. *J Natl Cancer Inst* 1996 Aug 7;88(15):1039-45.
- 10 **Gelber RD, Cole BF, Goldhirsch A, et al.** Adjuvant chemotherapy plus tamoxifen compared with tamoxifen alone for postmenopausal breast cancer: meta-analysis of quality-adjusted survival. *Lancet* 1996 Apr 20;347(9008):1066-71.
- 11 **Brown ML, Nayfield SG, Shibley LM.** Adjuvant therapy for stage III colon cancer: economics returns to research and cost-effectiveness of treatment. *J Natl Cancer Inst* 1994 Mar 16;86(6):424-30.
- 12 **Rosenthal MA, Webster PJ, Gebiski VJ, et al.** The cost of treating small cell lung cancer. *Med J Aust* 1992 May 4;156(9):605-10.

APPENDIX 4
Active and Pending Grants - Year 3

Department of Health and Human Services Public Health Service <h2 style="margin: 0;">Grant Application</h2> <p style="font-size: small; margin: 0;">Follow instructions carefully. Do not exceed character length restrictions indicated on sample.</p>	LEAVE BLANK-FOR PHS USE ONLY. <table border="1" style="width:100%; border-collapse: collapse;"> <tr> <td style="width:33%;">Type</td> <td style="width:33%;">Activity</td> <td style="width:33%;">Number</td> </tr> <tr> <td>Review Group</td> <td>Formerly</td> <td></td> </tr> <tr> <td colspan="2">Council/Board (Month, Year)</td> <td>Date Received</td> </tr> </table>	Type	Activity	Number	Review Group	Formerly		Council/Board (Month, Year)		Date Received
Type	Activity	Number								
Review Group	Formerly									
Council/Board (Month, Year)		Date Received								

1. TITLE OF PROJECT (Do not exceed 56 characters, including spaces and punctuation.)
Breast Cancer: Preparing for Survivorship

2. RESPONSE TO SPECIFIC REQUEST FOR APPLICATIONS OR PROGRAM ANNOUNCEMENT NO YES (If "Yes," state number and title)
 Number: _____ Title: _____

3. PRINCIPAL INVESTIGATOR/PROGRAM DIRECTOR

3a. NAME (Last, first, middle) Ganz, Patricia A.	3b. DEGREE(S) M.D.	3c. SOCIAL SECURITY NO.
3d. POSITION TITLE Professor	3e. MAILING ADDRESS (Street, city, state, zip code) UCLA Division of Cancer Prevention & Control Research 1100 Glendon Ave #711 Los Angeles, CA 90024-3511	
3f. DEPARTMENT, SERVICE, LABORATORY, OR EQUIVALENT School of Public Health		
3g. MAJOR SUBDIVISION Division of Cancer Prevention & Control Research (DCPCR)		
3h. TELEPHONE AND FAX (Area code, number and extension) TEL: (310) 825-3181 FAX: (310) 206-3566		E-MAIL ADDRESS: snavab@ucla.edu

4. HUMAN SUBJECTS <input type="checkbox"/> No <input checked="" type="checkbox"/> Yes	4a. If "Yes," Exemption no. or IRB approval date <input checked="" type="checkbox"/> Full IRB or <input type="checkbox"/> Expedited Review Pending	4b. Assurance of compliance no. M-1127	5. VERTEBRATE ANIMALS <input checked="" type="checkbox"/> No <input type="checkbox"/> Yes	5a. If "Yes," IACUC approval date	5b. Animal welfare assurance no. N/A
---	--	--	---	-----------------------------------	--

6. DATES OF PROPOSED PERIOD OF SUPPORT (month, day, year-MM/DD/YY) From 07/01/98 Through 06/30/02	7. COSTS REQUESTED FOR INITIAL BUDGET PERIOD 7a. Direct Costs (\$) \$498,049	7b. Total Costs (\$) \$567,367	8. COSTS REQUESTED FOR PROPOSED PERIOD OF SUPPORT 8a. Direct Costs (\$) \$1,929,032	8b. Total Costs (\$) \$2,147,441
--	--	---------------------------------------	---	---

9. APPLICANT ORGANIZATION Name University of California, Los Angeles Address The Regents of the University of California Division of Cancer Prevention & Control Research 405 Hilgard Avenue Los Angeles, CA 90095-1406	10. TYPE OF ORGANIZATION Public: → <input checked="" type="checkbox"/> Federal <input checked="" type="checkbox"/> State <input type="checkbox"/> Local Private: → <input type="checkbox"/> Private Nonprofit Forprofit: → <input type="checkbox"/> General <input type="checkbox"/> Small Business
	11. ORGANIZATIONAL COMPONENT CODE 13
	12. ENTITY IDENTIFICATION NUMBER 1956006143A1 Congressional District 29

13. ADMINISTRATIVE OFFICIAL TO BE NOTIFIED IF AWARD IS MADE Name Gina Barnett Title Grants Specialist Address 1400 PVUB Box 951406 Los Angeles, CA 90095-1406 Phone (310) 825-8561 FAX (310) 206-4996 E-Mail Address	14. OFFICIAL SIGNING FOR APPLICANT ORGANIZATION Name Gina Barnett Title Grants Specialist Address 1400 PVUB Box 951406 Los Angeles, CA 90095-1406 Phone (310) 825-8561 FAX (310) 206-4996 E-Mail Address
---	---

15. PRINCIPAL INVESTIGATOR/PROGRAM DIRECTOR ASSURANCE: I certify that the statements herein are true, complete and accurate to the best of my knowledge. I am aware that any false, fictitious, or fraudulent statements or claims may subject me to criminal, civil, or administrative penalties. I agree to accept responsibility for the scientific conduct of the project and to provide the required progress reports if a grant is awarded as a result of this application.	SIGNATURE OF PI/PPD NAMED IN 3a. (In ink. "Per" signature not acceptable.) 	DATE 10/28/97
--	--	-------------------------

16. APPLICANT ORGANIZATION CERTIFICATION AND ACCEPTANCE: I certify that the statements herein are true, complete and accurate to the best of my knowledge, and accept the obligation to comply with Public Health Service terms and conditions if a grant is awarded as a result of this application. I am aware that any false, fictitious, or fraudulent statements or claims may subject me to criminal, civil, or administrative penalties.	SIGNATURE OF OFFICIAL NAMED IN 14. (In ink. "Per" signature not acceptable.)	DATE
--	--	------

DESCRIPTION. State the application's broad, long-term objectives and specific aims, making reference to the health relatedness of the project. Describe concisely the research design and methods for achieving these goals. Avoid summaries of past accomplishments and the use of the first person. This description is meant to serve as a succinct and accurate description of the proposed work when separated from the application. If the application is funded, this description, as is, will become public information. Therefore, do not include proprietary/confidential information. **DO NOT EXCEED THE SPACE PROVIDED.**

Although considerable research attention has addressed the psychosocial concerns of breast cancer patients, little is known about the transition from active treatment to survivorship. Clinical experience and limited data suggest that this period can be particularly stressful. In this competing continuation, we propose to develop and evaluate a relatively low-cost psychoeducational preparatory intervention to facilitate this transition. The proposed study builds on our prior research program in quality of life and breast cancer.

In this multi-center study, we will register 1260 newly-diagnosed breast cancer patients from Los Angeles, Washington, D.C., and Kansas City, KS, one month after definitive surgery, and prospectively recruit them for participation in a randomized controlled trial (RCT) designed to test and evaluate three different intervention approaches for improving post-treatment patient outcomes. The interventions will occur after the completion of primary/adjuvant therapy. We expect to consent and randomize at least 630 women to one of 3 groups: (A) CONTROL CONDITION: standard written information (NCI publication "Facing Forward"); (B) MINIMAL INTERVENTION: control + videotape that models coping and addresses the transition from patient to survivor; and (C) HIGH INTENSITY INTERVENTION: minimal intervention + brief counseling (one in-person session with follow-up telephone call) + additional written materials. We hypothesize that a brief, preparatory intervention that includes counseling will be the most effective strategy for improving the quality of life during the transition for patient to survivor.

The specific aims of this application are: (1) to measure the impact of the 3 preparatory interventions on subsequent cognitive adaptation, and emotional, physical and interpersonal functioning, 2 and 6 months after the intervention; (2) to evaluate a model derived from self-regulation and stress and coping theories which postulates that promotion of realistic expectancies regarding the treatment transition and of specific approach-oriented coping strategies will serve as mediators of the intervention's effectiveness on adaptive outcomes; (3) to conduct an economic evaluation of the RCT strategies, and to calculate the incremental costs per unit change in specific dimensions of quality of life.

PERFORMANCE SITE(S) (organization, city, state)

University of California, Los Angeles
 University of Southern California, Los Angeles
 Georgetown University, Washington, D.C.
 University of Kansas, Lawrence

KEY PERSONNEL. See instructions on Page 11. Use continuation pages as needed to provide the required information in the format shown below.

Name	Organization	Role on Project
Patricia Ganz, MD	UCLA Schools of Medicine & Public Health	Principal Investigator
Thomas Belin, PhD	UCLA Departments of Psychiatry & Biostatistics	Co-Investigator
Gail Wyatt, PhD	UCLA Department of Psychiatry & Biobehavioral Science	Co-Investigator
Beth Leedham, PhD	UCLA School of Public Health	Project Director
Antronette Yancey, MD MPH	UCLA School of Public Health	Investigator
Beth Meyerowitz, PhD	University of Southern California	Co-P.I.
Julia Rowland, PhD	Georgetown University	Co-P.I.
Jeanne Mandelblatt, MD MPH	Georgetown University	Co-Investigator
John Lynch, MD	Medlantic Research Institute	Co-Investigator
Annette Stanton, PhD	University of Kansas	Co-P.I.
Carol Fabian, MD	University of Kansas	Co-Investigator
Robert Belt, MD	Oncology & Hematology Associates of Kansas City	Consultant

Department of Health and Human Services
Public Health Service

Grant Application

Follow instructions carefully.

Do not exceed character length restrictions indicated on sample.

LEAVE BLANK-FOR PHS USE ONLY

Type	Activity	Number
Review Group	Formerly	
Council/Board(Month/Year)	Date Received	

1. TITLE OF PROJECT (DO not exceed 56 characters, including spaces and punctuation.)
Interactive Decision - Aid for BRCA1/2 Mutation Carriers

2. RESPONSE TO SPECIFIC REQUEST FOR APPLICATIONS OR PROGRAM ANNOUNCEMENT NO YES (If "Yes" state number and title)
NEW INVESTIGATOR

3. PRINCIPAL INVESTIGATOR/PROGRAM DIRECTOR

3a. NAME (Last, first, middle) Schwartz, Marc	3b. DEGREE(S) Ph.D.	3c. SOCIAL SECURITY NO.
3d. POSITION TITLE Assistant Professor	3e. MAILING ADDRESS (Street, city, state, zip code) Lombardi Cancer Center Georgetown University Medical Center 2233 Wisconsin Avenue, NW - Suite 317 Washington, DC 20007-4104	
3f. DEPARTMENT, SERVICE, LABORATORY, OR EQUIVALENT Lombardi Cancer Center		
3g. MAJOR SUBDIVISION Georgetown University Medical Center		
3h. TELEPHONE AND FAX (Area code, number and extension) TEL: (202) 687-0185 FAX: (202) 687-8444	Schwartzm@gunet.georgetown.edu E-MAIL ADDRESS	

9-25-98 loc

4. HUMAN SUBJECTS <input type="checkbox"/> No <input checked="" type="checkbox"/> Yes	4a. If "Yes", Exemption no. or IRB approval date <input checked="" type="checkbox"/> Full IRB Expedite or <input type="checkbox"/> Review 02/19/98	4b. Assurance of Compliance M-1255	5. VERTEBRATE ANIMALS <input checked="" type="checkbox"/> No <input type="checkbox"/> Yes	5a. If "Yes," IACUC approval date	5b. Animal welfare assurance no.
---	---	---------------------------------------	--	-----------------------------------	----------------------------------

6. DATES OF PROPOSED PERIOD OF SUPPORT (month, day, year--MM/DD/YY) From 07/01/99 Through 06/30/04	7. COSTS REQUESTED FOR INITIAL BUDGET PERIOD 7a. Direct Costs (\$) 404,198 7b. Total Costs (\$) 594,815	8. COSTS REQUESTED FOR PROPOSED PERIOD OF SUPPORT 8a. Direct Costs (\$) 2,279,241 8b. Total Costs (\$) 3,169,643
---	---	--

9. APPLICANT ORGANIZATION Name Georgetown University Address 37th and O Streets, NW Washington, DC 20057	10. TYPE OF ORGANIZATION Public: <input type="checkbox"/> Federal <input type="checkbox"/> State <input type="checkbox"/> Local Private: <input checked="" type="checkbox"/> Private Nonprofit Forprofit: <input type="checkbox"/> General <input type="checkbox"/> Small Business	11. ORGANIZATIONAL COMPONENT CODE 01	12. ENTITY IDENTIFICATION NUMBER 1-530196603-A1 Congressional District DC
---	---	--------------------------------------	---

13. ADMINISTRATIVE OFFICIAL TO BE NOTIFIED IS AWARD IS MADE Name Lenny Fraser Title Grants and Contracts Officer Address Division of Research Grants and Contracts 4000 Reservoir Road, NW, Suite 177, Building D Washington, DC 20007 Telephone (202) 687-1366 FAX (202) 687-8263 E-Mail Fraserl@odrge.odr.georgetown.edu Address	14. OFFICIAL SIGNING FOR APPLICANT ORGANIZATION Name William J. Hartman Title Director Address Research and Technology Development Services 4000 Reservoir Road, NW, Suite 177, Building D Washington, DC 20007 Phone (202) 687-1390 FAX (202) 687-8263 E-Mail Address Hartmanj@odrge.odr.georgetown.edu
---	---

15. PRINCIPAL INVESTIGATOR/PROGRAM DIRECTOR ASSURANCE: I certify that the statements herein are true, complete and accurate to the best of my knowledge. I am aware that any false, fictitious, or fraudulent statements or claims may subject me to criminal, civil, or administrative penalties. I agree to accept responsibility for the scientific conduct of the project and to provide the required progress reports if a grant is awarded as a result of this application.	SIGNATURE OF P/PPD NAMED IN 3a. (In ink. "Per" signature not acceptable.) M - Schwartz	DATE 9/15/98
--	---	-----------------

16. APPLICANT ORGANIZATION CERTIFICATION AND ACCEPTANCE: I certify that the statements herein are true, complete and accurate to the best of my knowledge, and accept the obligation to comply with Public Health Service terms and conditions if a grant is awarded as a result of this application. I am aware that any false, fictitious, or fraudulent statements or claims may be subject to criminal, civil, or administrative penalties.	SIGNATURE OF OFFICIAL NAMED IN 14. (In ink. "Per" signature not acceptable.) [Signature]	DATE 9/27/98
--	---	-----------------

DESCRIPTION. State the application's broad, long-term objectives and specific aims, making reference to the health relatedness of the project. Describe concisely the research design and methods for achieving these goals. Avoid summaries of past accomplishments and the use of the first person. This description is meant to serve as a succinct and accurate description of the proposed work when separated from the application. If the application is funded, this description, as is, will become public information. Therefore, do not include proprietary/confidential information. **DO NOT EXCEED THE SPACE PROVIDED.**

Since the identification of the BRCA1 and BRCA2 breast cancer susceptibility genes, genetic testing has become increasingly widespread. Women who inherit a BRCA1/2 mutation have a 55%-85% lifetime risk of breast cancer. The primary medical decision facing these women is whether to have prophylactic mastectomy (breast removal) or to receive yearly mammograms. Since there are limited data on the effectiveness of these options among BRCA1/2 carriers, women are informed about the benefits and limitations of each and counseled to select an option that is most consistent with their personal preferences and values. Although a specific recommendation for surgery versus surveillance is not generally made, BRCA1/2 carriers who do not elect surgery are advised to obtain annual mammograms. Given the lack of clear guidelines for this decision, it is not surprising that medical decision-making is reported to be one of the most challenging and stressful consequences of receiving a positive BRCA1/2 gene test result, and a substantial proportion of carriers fail to adopt either option.

Therefore, the goal of this project is to develop and evaluate an interactive CD-ROM-based decision-aid for women who have recently received a positive BRCA1/2 gene test result. We propose a randomized trial among BRCA1 and BRCA2 mutation carriers in which we will compare standard genetic counseling (SGC) to an enhanced genetic counseling condition that consists of the individualized decision-aid (IDA) delivered in conjunction with standard genetic counseling. The IDA will be based, in part, on Subjective Expected Utility theory. Utility theory posits that in choosing between two alternatives (e.g., to have prophylactic mastectomy or annual mammography), individuals should choose the option that maximizes positive outcomes and minimizes negative outcomes. The value that an individual places on a particular health outcome is referred to as her *preference* or *utility*. Literature on decision-making in other medical contexts suggests that decision-aid interventions guided by Utility theory can promote informed decision-making and enhance psychological well-being. If effective, the IDA can easily be disseminated to BRCA1/2 carriers across the country and adapted for use with other populations with inherited risk for cancer.

PERFORMANCE SITE(S) (organization, city, state)
Georgetown University Medical Center, Washington DC
Mount Sinai School of Medicine, New York, NY

KEY PERSONNEL. See instructions on Page 11. Use continuation pages as needed to provide the required information in the format shown below.

Name	Organization	Role on Project
Marc Schwartz, Ph.D.	Georgetown University Medical Center	PI
Caryn Lerman, Ph.D.	Georgetown University Medical Center	Co-PI
Beth Peshkin, M.S.	Georgetown University Medical Center	Co-I
William Lawrence, M.D.	Georgetown University Medical Center	Co-I
Kevin Schulman, M.D.	Georgetown University Medical Center	Co-I
Lee-Jun Wong, Ph.D.	Georgetown University Medical Center	Co-I
Claudine Isaacs, M.D.	Georgetown University Medical Center	Co-I
Heiddis Valdimarsdottir, Ph.D.	Mt. Sinai School of Medicine	Co-PI (Site PI)
Christina Eng, M.D.	Mt. Sinai School of Medicine	Co-I
Karen Brown, M.S.	Mt. Sinai School of Medicine	Co-I

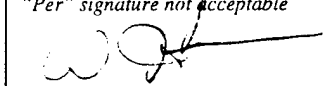
Department of Health and Human Services Public Health Service		LEAVE BLANK-FOR PHS USE ONLY	
Grant Application <i>Follow instructions carefully.</i> Do not exceed character length restrictions indicated on sample.		Type	Activity
		Review Group	Formerly
		Council/Board (Month/Year)	Date Received
1. TITLE OF PROJECT (DO not exceed 56 characters, including spaces and punctuation) CANCER CENTER SUPPORT GRANT			
2. RESPONSE TO SPECIFIC REQUEST FOR APPLICATIONS OR PROGRAM ANNOUNCEMENT <input type="checkbox"/> NO <input checked="" type="checkbox"/> YES (If "Yes" state number and title) ADMINISTRATIVE SUPPLEMENT TO STUDY THE IMPACT OF CANCER ON THE FAMILY			
3. PRINCIPAL INVESTIGATOR/PROGRAM DIRECTOR		New Investigator <input type="checkbox"/> Yes	
3a. NAME (Last, first, middle) Lippman, Marc, E.	3b. DEGREES MD	3c. SOCIAL SECURITY NO. <i>Provide on Form Page KK.</i>	
3d. POSITION TITLE Director	3e. MAILING ADDRESS (Street, city, state, zip code) Lombardi Cancer Center The Research Building Georgetown University Medical Center 3970 Reservoir Road NW Washington, DC 20007-2197		
3f. DEPARTMENT, SERVICE, LABORATORY, OR EQUIVALENT) Lombardi Cancer Center			
3g. MAJOR SUBDIVISION Medicine			
3h. TELEPHONE AND FAX (Area code, number and extension) TEL: (202) 687-2110 FAX: (202) 687-6402		E-MAIL ADDRESS lippmanm@gunet.georgetown.edu	
4. HUMAN SUBJECTS <input type="checkbox"/> No <input checked="" type="checkbox"/> Yes	4a. If "Yes", Exemption no. or IRB approval date Pending	4b. Assurance of Compliance Full IRB or Expedite Review M-1255	5. VERTEBRATE ANIMALS <input checked="" type="checkbox"/> No or <input type="checkbox"/> Yes
		5a. If "Yes" IACUC Approval	5b. Animal welfare assurance no.
6. DATES OF PROPOSED PERIOD OF SUPPORT (month, day, year—MM/DD/YY) From 10/01/99 Through 09/30/00	7. COSTS REQUESTED FOR INITIAL BUDGET PERIOD 7a. Direct Costs (\$) 100,000	7b. Total Costs (\$) 154,966	8. COSTS REQUESTED FOR PROPOSED PERIOD OF SUPPORT 8a. Direct Costs (\$) 100,000 8b. Total Costs (\$) 154,966
9. APPLICANT ORGANIZATION Name Georgetown University Address 37 & O Streets NW Washington, DC 20057		10. TYPE OF ORGANIZATION Public: → <input type="checkbox"/> Federal <input type="checkbox"/> State <input type="checkbox"/> Local Private: → <input checked="" type="checkbox"/> Private Nonprofit For profit: → <input type="checkbox"/> General <input type="checkbox"/> Small Business	
		11. ORGANIZATION CODE 01	
		12. ENTITY IDENTIFICATION NUMBER 1-530196603-A1	Congressional District DC
13. ADMINISTRATIVE OFFICIAL TO BE NOTIFIED IS AWARD IS MADE Name William J. Hartman Title Director Address Research and Technology Development Services 4000 Reservoir Road NW, Suite 177, Bldg D Washington, DC 20007-2197 Telephone: (202) 687-1390 Fax: (202) 687-8263 E-mail hartmanj@odrge.odr.georgetown.edu		14. OFFICIAL SIGNING FOR APPLICATION ORGANIZATION Name William J. Hartman Title Director Address Research and Technology Development Services 4000 Reservoir Road NW, Suite 177, Bldg D Washington, DC 20007-2197 Telephone: (202) 687-1390 Fax: (202) 687-8263 E-mail hartmanj@odrge.odr.georgetown.edu	
15. PRINCIPAL INVESTIGATOR/PROGRAM DIRECTOR ASSURANCE: I certify that the statements herein are true, complete and accurate to the best of my knowledge. I am aware that any false, fictitious, or fraudulent statements or claims may subject me to criminal, civil or administrative penalties. I agree to accept responsibility for the scientific conduct of the project and to provide the required progress report if a grant is awarded as a result of this application.		SIGNATURE OF PI/PD NAMED IN 3A. (In ink. "Per" signature not acceptable 	DATE 9/29/99
16. APPLICANT ORGANIZATION CERTIFICATION AND ACCEPTANCE: I certify that the statements herein are true, complete and accurate to the Best of my knowledge, and accept the obligation to comply with Public Health Service terms and conditions if a grant is awarded as a result of this application. I am aware that any false, fictitious, or fraudulent statements or claims may be subject to criminal, civil, or administrative penalties.		SIGNATURE OF PI/PD NAMED IN 14. (In ink. "Per" signature not acceptable 	DATE 5/11/99

DESCRIPTION. State the application's broad, long-term objectives and specific aims, making reference to the health relatedness of the project. Describe concisely the research design and methods for achieving these goals. Avoid summaries of past accomplishments and the use of the first person. This description is meant to serve as a succinct and accurate description of the proposed work when separated from the application. If the application is funded, this description as is, will become public information. Therefore, do not include proprietary/confidential information. **DO NOT EXCEED THE SPACE PROVIDED.**

As a consequence of recent advances in cancer detection and treatment many patients are living for long periods with advanced disease. Patients and families who are living with advanced disease may encounter emotional distress, increasing physical limitations, symptomatic discomfort, and financial hardship. For the caregivers, family members and friends providing unpaid patient care, emotional distress, increased morbidity, and higher risk of mortality may also extend beyond the patient's death.

Very little work has focused on the trajectory of caregiver burden, needs, distress, and health resource utilization in this population. This lack of data and other methodologic complications significantly limits the introduction and evaluation of interventions targeted to caregivers. To begin to fill this important gap in the quality of care for cancer patients and their families, a multidisciplinary research team from the Lombardi Cancer Center's Palliative Care program, Developmental Therapeutics (DT) Program, and Cancer Clinical and Economic Outcomes Core will use a conceptual framework of the caregiving experience to conduct a descriptive study of caregivers of seriously ill cancer patients in a population of caregivers of patients participating in phase I clinical trials, a population that is likely to have little formalized support and one is that unique to cancer centers. This study will primarily address methodologic issues associated with research in this population with the overall goal of the project being to develop a framework for subsequent intervention studies.

PERFORMANCE SITES (Organization, city, state)

Lombardi Cancer Center
Georgetown University Medical Center
The Research Building
3970 Reservoir Road NW
Washington, DC 20007-2197

KEY PERSONNEL. See instructions on Page 11. Use continuation pages as needed to provide the required information in the format shown

Name	Organization	Role on Project
Marc Lippman, MD	Georgetown University Medical Center	Principal Invest.
Jane Ingham, MBBS	Georgetown University Medical Center	Co-Investigator
Jeanne Mandelblatt, MD, MPH	Georgetown University Medical Center	Co-Investigator
Kathryn Taylor, PhD	Georgetown University Medical Center	Co-Investigator
K. Robin Yabroff, MBA	Georgetown University Medical Center	Co-Investigator
John Marshall, MD	Georgetown University Medical Center	Co-Investigator
Caroline Burnett, RN, ScD	Georgetown University Medical Center	Co-Investigator

Department of Health and Human Services Public Health Service Grant Application <i>Follow instructions carefully. Do not exceed character length restrictions indicated on sample.</i>	LEAVE BLANK—FOR PHS USE ONLY.		
	Type	Activity	Number
	Review Group		Formerly
	Council/Board (Month, Year)		Date Received

1. TITLE OF PROJECT
A RCT to Enhance Mammography Utilization Among African-American Women

2. RESPONSE TO SPECIFIC REQUEST FOR APPLICATIONS OR PROGRAM ANNOUNCEMENT NO YES (If "Yes," state number and title)
Number: PA-96-034 Title: Aging Women and Breast Cancer

3. PRINCIPAL INVESTIGATOR/PROGRAM DIRECTOR New Investigator YES

3a. NAME (Last, first, middle) Adams-Campbell, Lucile L. 3b. DEGREE(S) Ph.D.

3d. POSITION TITLE Professor 3e. MAILING ADDRESS (Street, city, state, zip code)

3f. DEPARTMENT, SERVICE, LABORATORY, OR EQUIVALENT Medicine Howard University Cancer Center
2041 Georgia Avenue, N.W.
Washington, D.C. 20060

3g. MAJOR SUBDIVISION Cancer Center

3h. TELEPHONE AND FAX (Area code, number and extension)
TEL: (202) 806-7697
FAX: (202) 667-1686 E-MAIL ADDRESS: ladams-campbell@howard.edu

4. HUMAN SUBJECTS	4a. If "Yes," Exemption no.	4b. Assurance of compliance no.	5. VERTEBRATE ANIMALS	5a. If "Yes," IACUC approval date	5b. Animal welfare assurance no.
<input type="checkbox"/> No <input checked="" type="checkbox"/> Yes	IRB approval date Pending	M1102	<input checked="" type="checkbox"/> No <input type="checkbox"/> Yes		

6. DATES OF PROPOSED PERIOD OF SUPPORT (month, day, year—MM/DD/YY) From 1/1/00 Through 12/31/05	7. COSTS REQUESTED FOR INITIAL BUDGET PERIOD 7a. Direct Costs (\$) 342,708	8. COSTS REQUESTED FOR PROPOSED PERIOD OF SUPPORT 7b. Total Costs (\$) 454,733 8a. Direct Costs (\$) 1,743,437 8b. Total Costs (\$) 2,026,885
--	---	--

9. APPLICANT ORGANIZATION
Name Howard University Cancer Center
Address 2041 Georgia Avenue, N.W.
Washington, D.C. 20060

10. TYPE OF ORGANIZATION
Public: Federal State Local
Private: Private Nonprofit
Forprofit: General Small Business

11. ORGANIZATIONAL COMPONENT CODE

12. ENTITY IDENTIFICATION NUMBER 1530204707A1
DUNS NO. (if available) Congressional District DC

13. ADMINISTRATIVE OFFICIAL TO BE NOTIFIED IF AWARD IS MADE Name Gary L. Harris, Ph.D. Title Assoc. Vice President for Research Address 2400 Sixth Street, N.W. P.O. Box 1071 Washington, D.C. 20059 Telephone (202) 806-5567 Fax (202) 806-5523 E-mail gharris@msrce.howard.edu	14. OFFICIAL SIGNING FOR APPLICANT ORGANIZATION Name Gary L. Harris, Ph.D. Title Assoc. Vice President for Research Address 2400 Sixth Street, N.W. P.O. Box 1071 Washington, D.C. 20059 Telephone (202) 806-5567 Fax (202) 806-5523 E-mail gharris@msrce.howard.edu
--	--

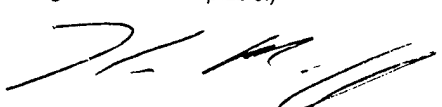
15. PRINCIPAL INVESTIGATOR/PROGRAM DIRECTOR ASSURANCE: I certify that the statements herein are true, complete and accurate to the best of my knowledge. I am aware that any false, fictitious, or fraudulent statements or claims may subject me to criminal, civil, or administrative penalties. I agree to accept responsibility for the scientific conduct of the project and to provide the required progress reports if a grant is awarded as a result of this application.	SIGNATURE OF PI / PD NAMED IN 3a. (In ink. "Per" signature not acceptable.) 	DATE 5/25/99
--	---	-----------------

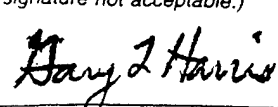
16. APPLICANT ORGANIZATION CERTIFICATION AND ACCEPTANCE: I certify that the statements herein are true, complete and accurate to the best of my knowledge, and accept the obligation to comply with Public Health Service terms and conditions if a grant is awarded as a result of this application. I am aware that any false, fictitious, or fraudulent statements or claims may subject me to criminal, civil, or administrative penalties.	SIGNATURE OF OFFICIAL NAMED IN 14. (In ink. "Per" signature not acceptable.) 	DATE 6/1/99
--	--	----------------

BB Principal Investigator/Program Director (Last, first, middle): [Principal Investigator/Prog Dir]

DESCRIPTION. State the application's broad, long-term objectives and specific aims, making reference to the health relatedness of the project. Describe concisely the research design and methods for achieving these goals. Avoid summaries of past accomplishments and the use of the first person. This description is meant to serve as a succinct and accurate description of the proposed work when separated from the application. If the application is funded, this description, as is, will become public information. Therefore, do not include proprietary/confidential information. **DO NOT EXCEED THE SPACE PROVIDED.**

In the last two decades, the death rate from breast cancer has fallen by about seven percent in women under 65. However, elderly African-American women have yet to realize any mortality reductions. In fact, in this period, elderly African-American women have experienced a 26% increase in mortality, despite having lower incidence of disease than their white counterparts. The lack of mortality reduction in elderly African-American women may be explained, in part, by the fact that mortality reductions assume regular, on-going screening. However, for all women, rates of regular, on-going screening mammograms remain below recommended levels. There are little data on methods to enhance regular, on-going breast cancer screening, and fewer data still on how to increase utilization of regular screening in elderly African-American women. To address this important gap in knowledge, Howard University Cancer Center and The Georgetown University's Division of Cancer Prevention and Control Cancer and the Cancer Clinical Outcomes and Economics Core of the Lombardi Cancer Center, Division of Cancer Prevention and Control, are collaborating on this important project. The primary goal of this multi-disciplinary, inter-institutional consortium is to conduct and evaluate a community-based 2 x 2 factorially designed randomized clinical trial (RCT) to increase regular screening rates. We will use the Preceed/Proceed Model as the theoretical framework to guide the design and analyses. A sample of over 4000 elderly African-American women, with a history of at least one previous mammogram, will be accessed by random-digit dialing and randomized to one of four arms: group counseling, tailored print reminders, a combination of counseling and tailored print reminders, and usual care as (control). The project has three primary aims: 1) To test the hypothesis that the Preceed/Proceed Model, which describes predisposing, enabling, and reinforcing factors, predicts regular screening; 2) To test the hypothesis that women who receive the combination of the tailored print communications and the community-based counseling will adhere to regular mammography screening (i.e., two films in two years) at significantly higher rates than those in the other three arms; 2a) To test the durability of the RCT effects on regular mammography screening over two years post-randomization; and 4) To use cost-effectiveness analyses to test the hypothesis that the combination of tailored print communication and community-based counseling will have the lowest incremental costs per additional woman adherent with return mammography than either intervention alone, or than the control. These data are critical to our success in reducing the disproportionately high breast cancer mortality and morbidity experienced by elderly African-American women.

PERFORMANCE SITE(S) (organization, city, state)

Howard University Cancer Center (HUCC)
2041 Georgia Ave. NW
Washington, D.C. 20060

Division of Cancer Prevention and Control/Lombardi Cancer Center (DCPC/LCC), Georgetown University
2233 Wisconsin Ave. NW Suite 400
Washington, D. C. 20007

KEY PERSONNEL. See instructions on Page 11. Use continuation pages as needed to provide the required information in the format shown below.

Name	Organization	Role on Project
Lucile Adams-Campbell, PhD	HUCC	PI
Caroline B. Burnett, RN, ScD	DCPC/LCC, Georgetown University	Co-PI, & (P.I., sub contract)
Personnel: HUCC		
Eva	HUCC	Co-Investigator
Paige McDonald, PhD	HUCC	Co-Investigator
Dionne Thorne MPH	HUCC	Health Educator
Project Coordinator (TBA)	HUCC	
Stat/RA, data entry (TBA)	HUCC	
Personnel: DCPC/LCC		
Jeanne Mandelblatt, MD, MPH	DCPC/LCC	Co-Investigator
Research Assistant (TBA)	DCPC/LCC	Support PI; coordinate activities with HUCC
Cancer Clinical Outcomes and Economics Core	DCPC/LCC	Provide CEA

AA

Department of Health and Human Services Public Health Service <h2 style="text-align: center;">Grant Application</h2> <p style="text-align: center;">Follow instructions carefully. Do not exceed character length restrictions indicated on sample.</p>	LEAVE BLANK--FOR PHS USE ONLY.		
	Type	Activity	Number
	Review Group	Formerly	
	Council/Board (Month, Year)		Date Received

1. TITLE OF PROJECT (Do not exceed 56 characters, including spaces and punctuation.)
Cohort Study of Cancer Patient Caregiver Outcomes

2. RESPONSE TO SPECIFIC REQUEST FOR APPLICATIONS OR PROGRAM ANNOUNCEMENT NO YES (If "Yes," state number and title)
 Number: NR-99-004 Title: Research on Care at the End of Life

3. PRINCIPAL INVESTIGATOR/PROGRAM DIRECTOR

3a. NAME (Last, first, middle) Ingham, Jane	3b. DEGREE(S) MBBS	3c. SOCIAL SECURITY NO. Provide on Form Page KK
3d. POSITION TITLE Assistant Professor of Medicine	3e. MAILING ADDRESS (Street, city, state, zip code) Lombardi Building, Podium Level, Corridor B 3800 Reservoir Road, NW Washington DC 20007	
3f. DEPARTMENT, SERVICE, LABORATORY, OR EQUIVALENT Lombardi Cancer Center		
3g. MAJOR SUBDIVISION Georgetown University Medical Center		
3H. TELEPHONE AND FAX (Area code, number and extension) TEL: 202-687-6563 FAX: 202-687-2886	E-MAIL ADDRESS: inghamj@gunet.georgetown.edu	

4. HUMAN SUBJECTS <input checked="" type="checkbox"/> No <input type="checkbox"/> Yes	4a. If "Yes" Exemption no. or IRB approval date Pending	4b. Assurance of compliance no. M-1255	5. VERTEBRATE ANIMALS <input checked="" type="checkbox"/> No <input type="checkbox"/> Yes	5a. If "Yes" IACUC approval date	5b. Animal welfare assurance no.
--	---	--	--	----------------------------------	----------------------------------

6. DATES OF PROPOSED PERIOD OF SUPPORT (month, day, year--MM/DD/YY) From 10/01/1999 Through 09/30/2002	7. COSTS REQUESTED FOR INITIAL BUDGET PERIOD 7a. Direct Costs (\$) 75,000	8. COSTS REQUESTED FOR PROPOSED PERIOD OF SUPPORT 7b. Total Costs (\$) 117,281 8a. Direct Costs (\$) 224,997 8b. Total Costs (\$) 351,276
---	---	---

9. APPLICANT ORGANIZATION Name Georgetown University Address 37th & O Streets, NW Washington, DC 20057	10. TYPE OF ORGANIZATION Public: <input type="checkbox"/> Federal <input type="checkbox"/> State <input type="checkbox"/> Local Private: <input checked="" type="checkbox"/> Private Nonprofit Forprofit: <input type="checkbox"/> General <input type="checkbox"/> Small Business
	11. ORGANIZATIONAL COMPONENT CODE 01
	12. ENTITY IDENTIFICATION NUMBER 1-53-019-6603-A1 DUNS NO. (if available)
	Congressional District DC

13. ADMINISTRATIVE OFFICIAL TO BE NOTIFIED IF AWARD IS MADE Name William J. Hartman Title Director Address Suite 177, Building D 4000 Reservoir Road, N.W., Washington, DC 20007 Telephone 202 687-1366 FAX 202 687-8263 E-Mail Address hartmanj@odrge.odr.georgetown.edu	14. OFFICIAL SIGNING FOR APPLICANT ORGANIZATION Name William J. Hartman Title Director, Research & Technology Development Serv. Address 4000 Reservoir Rd., NW Building D, Suite 177 Washington, DC 20007 Phone (202)687-1390 FAX (202)687-8263 E-Mail Address hartmanj@odrge.odr.georgetown.edu
---	--

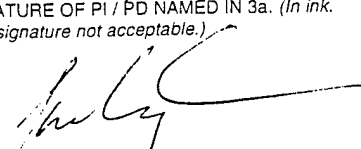
15. PRINCIPAL INVESTIGATOR/PROGRAM DIRECTOR ASSURANCE I certify that the statements herein are true, complete and accurate to the best of my knowledge. I am aware that any false, fictitious, or fraudulent statements or claims may subject me to criminal, civil, or administrative penalties. I agree to accept responsibility for the scientific conduct of the project and to provide the required progress reports if a grant is awarded as a result of this application.	SIGNATURE OF PI / PD NAMED IN 3a. (In ink. "Per" signature not acceptable.) 	DATE 5/19/99
---	---	------------------------

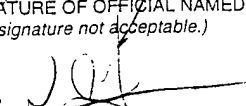
16. APPLICANT ORGANIZATION CERTIFICATION AND ACCEPTANCE: I certify that the statements herein are true, complete and accurate to the best of my knowledge, and accept the obligation to comply with Public Health Service terms and conditions if a grant is awarded as a result of this application. I am aware that any false, fictitious, or fraudulent statements or claims may subject me to criminal, civil, or administrative penalties.	SIGNATURE OF OFFICIAL NAMED IN 14. (In ink. "Per" signature not acceptable.) 	DATE 5/19/99
--	--	------------------------

DESCRIPTION. State the application's broad, long-term objectives and specific aims, making reference to the health relatedness of the project. Describe concisely the research design and methods for achieving these goals. Avoid summaries of past accomplishments and the use of the first person. This description is meant to serve as a succinct and accurate description of the proposed work when separated from the application. If the application is funded, this description, as is, will become public information. Therefore, do not include proprietary/confidential information. **DO NOT EXCEED THE SPACE PROVIDED.**

Despite recent advances in cancer detection and treatment, each year more than half a million cancer patients die from their disease. Patient's and families who are living with terminal cancer often encounter emotional distress, unmet needs, increasing physical limitations, symptomatic discomfort, and financial burdens. Despite the importance of caregivers in the care of patients with advanced cancer, there is a paucity of research describing the longitudinal outcomes of caregivers over the continuum of care from active patient illness to death, bereavement, and post bereavement.

To begin to fill these important knowledge gaps, a multidisciplinary research team from Lombardi Cancer Center will use a conceptual framework of the caregiving experience to conduct a longitudinal cohort study of caregivers of terminally ill cancer patients. The primary objectives of this study are to use a conceptual model of caregiving: 1) to describe caregiver burden and health outcomes over the continuum of care and 2) to address methodological issues associated with longitudinal research in this setting. We will conduct phased research to achieve these goals. In the first phase of the project, we will conduct six focus groups with individuals who are either active caregivers or bereaved. In the second phase of the project, we will use these data to conduct a longitudinal cohort study. The cohort will consist of nearly 300 caregivers of advanced gastrointestinal, lung, and breast cancer patients. Caregivers will be interviewed at enrollment, 2 and 4 months post-enrollment, and 3, 6, and 13 months post-bereavement.

The results of this project will serve as a framework for the development of future interventions to improve the quality of care for cancer patients and their families. In addition, approaches developed in this project should be broadly portable to studying the caregiver experience in caring for patients with other types of chronic and terminal illnesses.

PERFORMANCE SITE(S) (organization, city, state)

Lombardi Cancer Center, Georgetown University Medical Center

KEY PERSONNEL. See instructions on Page 11. Use continuation pages as needed to provide the required information in the format shown

Name	Organization	Role on Project
Jane Ingham, MBBS	Georgetown University Medical Center	PI
Jeanne Mandelblatt, MD, MPH	Georgetown University Medical Center	Co-Investigator
K. Robin Yabroff, MBA	Georgetown University Medical Center	Co-Investigator
Kathryn Taylor, PhD	Georgetown University Medical Center	Co-Investigator
Cheryl Arenella, MD	Northern Virginia Hospice	Consultant
Caroline Burnett, RN, ScD	Georgetown University Medical Center	Consultant
Daniel Hayes, MD	Georgetown University Medical Center	Consultant
Janice Krupnick, PhD	Georgetown University Medical Center	Consultant
John Marshall, MD	Georgetown University Medical Center	Consultant
Naiyer Rizvi, MD	Georgetown University Medical Center	Consultant

**PROPOSAL SUBMITTED IN RESPONSE
TO THE PROGRAM ANNOUNCEMENT
FOR THE
1999 PROSTATE CANCER RESEARCH PROGRAM**

**UNITED STATES ARMY MEDICAL RESEARCH
AND MATERIEL COMMAND**

PEER REVIEW REFERRAL PAGE

PROPOSAL TITLE: Preferences for Prostate Cancer Screening Outcomes

PRINCIPAL INVESTIGATOR: William F. Lawrence, MD, MS

KEYWORD DESCRIPTIVE TECHNICAL TERMS:

**Cancer prevention, Health preferences, Quality of life, Screening behaviors,
Population survey**

CONFLICT OF INTEREST CONSIDERATIONS: KEY PERSONNEL

NAME	DEGREE	DISCIPLINE	INSTITUTION	TITLE	ROLE
William Lawrence	MD	Internal Medicine	Georgetown Univ.	Assist. Prof.	P.I.
Kathryn Taylor	PhD	Psychology	Georgetown Univ.	Assist. Prof.	Co-PI
Jeanne Mandelblatt	MD	Internal Medicine	Georgetown Univ.	Assoc. Prof.	Investigator
Jon Kerner	PhD	Behavioral Science	Georgetown Univ.	Prof.	Investigator
Karen Gold	PhD	Biostatistics	Georgetown Univ.	Assist. Prof.	Investigator
John Lynch	MD	Urology	Georgetown Univ.	Prof.	Investigator
Wenchi Liang	PhD	Health Policy	Georgetown Univ.	Research Assoc.	Project Coordinator
Jackson Davis	MD	Urology		Urologist	Consultant
Ralph Turner	RN,PA	Nursing	Trifax Corp.	CEO	Consultant
Marilyn Schapira	MD	Internal Medicine	Medical College of Wisconsin	Assist. Prof.	Consultant

Submitted February/March 1999

TECHNICAL ABSTRACT

PROPOSAL TITLE: Preferences for Prostate Cancer Screening Outcomes
PRINCIPAL INVESTIGATOR: William F. Lawrence, MD, MS

In 1999, 179,000 men will develop and 37,000 men will die of prostate cancer. African-American men are more than twice as likely to die of this disease than white men. The high burden of prostate cancer morbidity and mortality makes this disease an attractive target for early detection efforts, particularly among African-American men. While tests are available to screen for this cancer, screening remains controversial, even in high-risk populations. In this situation, where the benefits of screening are uncertain, patient preference should guide the decision whether or not to screen. At present, however, there is a paucity of data on men's preferences for prostate cancer screening outcomes, and how these preferences influence men's screening behavior.

The goals of this research are two-fold. First, we use a conceptual model of preference theory and health service use as a novel approach to predict screening behavior, distress, and satisfaction with the screening decision in a population-based cohort of men. Second, we examine the impact of age and race on preferences for screening outcomes. To achieve these goals, we propose a longitudinal, population-based telephone survey of men in the District of Columbia metropolitan area, oversampling for areas with high proportion of African-American men. Data from this longitudinal cohort will be used to test the hypotheses that: 1) preferences for screening outcomes predict screening behavior, although age and race will be significant mediators of this relationship; 2) African-American men and older men, although at high risk for developing prostate cancer, will have lower preferences for screening than non-African-American men and younger men, respectively; and 3) men whose preferences are concordant with their screening behaviors will have lower distress and greater satisfaction compared to men whose preferences are discordant with their behaviors.

To test these hypotheses, we will conduct a random-digit-dial telephone survey of men in the District of Columbia and surrounding counties. Participants will include 1,000 men, stratified by race (African-American vs. non-African-American) and age (40-49, 50-64, 65-75 years). Participants will be asked about their prostate cancer screening preferences and about predisposing, enabling, and need factors that may potentially mediate the relationship between screening preferences and behaviors. A follow-up telephone survey will be conducted 15 months after the baseline, to determine study outcomes including screening behaviors, cancer-related distress, and satisfaction with the screening decision.

Because the utility of prostate cancer screening among asymptomatic men has not been demonstrated, even among those at high risk, the goal of this research is neither to encourage nor discourage prostate cancer screening. Rather, the goal is to understand further the relationship between men's preferences and behaviors, and to determine the mediating factors of this relationship. An understanding of the relationship between preferences and screening behaviors is essential to the development of interventions to assist men in making informed decisions consonant with their preferences for the potential screening outcomes.

**PROPOSAL SUBMITTED IN RESPONSE
TO THE BROAD AGENCY ANNOUNCEMENT
FOR
1999 BREAST CANCER PROGRAM**

**UNITED STATES ARMY MEDICAL RESEARCH
AND MATERIEL COMMAND**

PEER REVIEW REFERRAL PAGE

PROPOSAL TITLE: Breast Cancer Genetic Susceptibility Testing: A Primary Care Perspective

PRINCIPAL INVESTIGATOR: William F. Lawrence, MD, MS

KEYWORD DESCRIPTIVE TECHNICAL TERMS:

BRCA1/2 genetic testing, Cost-effectiveness analysis, Breast cancer prevention, Quality of life

CONFLICT OF INTEREST CONSIDERATIONS: KEY PERSONNEL

NAME	DEGREE	DISCIPLINE	INSTITUTION	TITLE	ROLE
William Lawrence	MD, MS	Internal Medicine	Georgetown Univ.	Assist. Prof.	P.I.
Caryn Lerman	PhD	Psychology	Georgetown Univ.	Professor	Investigator
Jeanne Mandelblatt	MD, MPH	Internal Medicine	Georgetown Univ.	Assoc. Prof.	Investigator
Claudine Isaacs	MD	Oncology	Georgetown Univ.	Assistant Prof	Investigator
Giovanni Parmigiani	PhD	Stat. & Decision Sci.	Duke Univ.	Assistant Prof.	Consultant

TECHNICAL ABSTRACT

PROPOSAL TITLE: Breast Cancer Genetic Susceptibility Testing: A Primary Care Perspective
PRINCIPAL INVESTIGATOR: William F. Lawrence, MD, MS

Recent studies have led to the identification of two breast cancer susceptibility genes, BRCA1 and BRCA2. Mutations in these genes may account for up to 10% of the 180,000 breast cancers diagnosed each year. Women carrying these mutations are at increased risk of both breast and ovarian cancers. While BRCA1/2 testing is currently considered a research tool, commercial tests are now available for use in clinical practice. Women and primary care providers have both expressed interest in breast cancer genetic testing; thus primary care providers represent great potential for use or misuse of such predictive testing. At present, there is a paucity of data on the risks, benefits, and costs of testing in primary care.

The goals of this research proposal are two-fold. First, we will extend a cost-effectiveness analysis of BRCA1/2 testing in high-risk women to include women in primary care settings. Second, we will use this extended model and current work in Bayesian analysis of the probability of being a BRCA1/2 mutation carrier to develop decision aids aimed at primary care providers and their patients to discuss the risks and benefits of testing. The technical objectives of the study are: 1) to extend a simulation model of the cost-effectiveness of BRCA1/2 testing in high-risk women to include women in primary care settings to identify women over a threshold risk who are most likely to benefit from testing at a reasonable societal cost, and to use effectiveness data from the model to detail expected cancer risk reduction, life expectancy, and quality-adjusted life expectancy outcomes for individual women identified as BRCA1/2 carriers; and 2) To translate the data from objective (1) into a format usable by primary care providers and their patients in joint decision making on BRCA1/2 testing, including translating the threshold level of risk identified for targeted testing into explicit family history based criteria, and developing a computer program which incorporates information from objective (1) with a woman's individual preferences for health states to provide individualized detailed health outcome information.

The investigators will modify an existing stochastic simulation model of the costs and outcomes of BRCA1/2 testing to examine 3 scenarios for women in primary care: offering testing to all women; identifying women at higher risk based on family history, and offering testing to these women; and do not test any women. Using this model, the threshold risk of carrying a mutation for which testing is cost-effective will be determined. We will use a Bayesian probability analysis to determine a set of family history criteria associated with the threshold level of risk. Health outcomes data from the model will be incorporated into a computer program to provide risk reduction, life expectancy, and individual level quality-adjusted life expectancy for women identified as carriers.

This study uses medical decision theory to develop an innovative approach to the evaluation of BRCA1/2 genetic testing, and develops a paradigm that will be widely applicable to other cancer genetic research issues. The simulation model will provide a novel combination of societal and individual perspectives on use of testing; we provide public health perspective data on the level of risk of carrying a mutation for which offering testing would be considered cost-effective, and provide individual perspective data incorporating women's preferences to estimate the quality-adjusted life expectancy of preventive and surveillance options for identified carriers. Future work will incorporate the decision aids into an educational intervention for primary care clinicians, and test the effectiveness of this intervention on clinician knowledge of breast cancer genetic susceptibility, attitudes towards testing, and genetic testing intentions and practices.

DESCRIPTION. State the application's broad, long-term objectives and specific aims, making reference to the health relatedness of the project. Describe concisely the research design and methods for achieving these goals. Avoid summaries of past accomplishments and the use of the first person. This description is meant to serve as a succinct and accurate description of the proposed work when separated from the application. If the application is funded, this description, as is, will become public information. Therefore, do not include proprietary/confidential information. **DO NOT EXCEED THE SPACE PROVIDED.**

Smoking is a major cause of avoidable morbidity and mortality in the United States. While over 70% of smokers would like to quit smoking, fewer than 10% succeed in quitting. Recently, the *SLC6A3* gene has been found to predispose smokers to nicotine dependence. A companion clinical trial (Project 2) proposed in this TTURC grant application will determine the efficacy of transdermal nicotine patches (TN) and nicotine nasal spray (NS) in smokers with protective and predisposing *SLC6A3* genotypes. However, the long-term health outcomes and costs of care associated with these cessation strategies are not known. To address this important gap, the investigators will use cost-effectiveness analysis to examine costs and outcomes of three strategies for smoking cessation: 1) using counseling and TN for all smokers making a quit attempt; 2) using counseling and NS for all smokers attempting to quit; and 3) gene testing all smokers making a quit attempt, and tailoring treatment such that those with protective genotypes receive counseling and TN, and those with predisposing genotypes receive counseling and NS. The specific aims of the study are 1) to collect health preference data from participants of a randomized clinical trial of NS versus TN to test the hypothesis that successful quitters have higher health-related quality of life than those making unsuccessful quit attempts, and 2) to perform a cost-effectiveness analysis incorporating health preference data from aim (1), longevity, and costs to test the hypothesis that using *SLC6A3* gene testing to tailor therapy will be cost-effective compared to treatment of all smokers with either TN or NS. The proposed study will have two components. First, health-preference data will be collected on at least 700 smokers enrolled in the clinical trial (Project 2). Second, a computer simulation model will be constructed which incorporates smokers' health preferences, clinical trial data from Project 2 on cessation rates for TN and NS stratified by gene status, and medical literature data on longevity based upon smoking status. This model will calculate the long-term costs and outcomes of the three cessation strategies. Results will be presented as incremental cost-effectiveness ratios with units of cost per quality-adjusted life year saved and cost per successful quit. The proposed study represents an innovative approach to the rapid assessment of *SLC6A3* gene testing. Data from this proposal will provide a framework for health policy guidelines that maximize the health of the smoking population for an acceptable cost.

PERFORMANCE SITE(S) (organization, city, state)

Georgetown University Medical Center, Washington, D.C.

KEY PERSONNEL. See instructions on Page 11. Use continuation pages as needed to provide the required information in the format shown

Name	Organization	Role on Project
William F. Lawrence, MD	Lombardi Cancer Center, Georgetown University	Principal Investigator
Wenchi Liang, PhD	Lombardi Cancer Center, Georgetown University	Project Coordinator

Cost-Effectiveness of *SLC6A3* Gene Testing to Direct Smoking Cessation Therapy**PI: William Lawrence, MD, MS****1. Specific Aims**

Smoking is a major cause of avoidable morbidity and mortality in the United States. While many current smokers are interested in quitting, and each year 30% of smokers attempt to quit, fewer than 10% succeed in quitting. Recently, the *SLC6A3* gene has been found to predispose smokers to nicotine dependence (Lerman, et al., 1999; Sabol, et al., 1999). A companion clinical trial (Project 2) proposed in this TTURC grant application will determine the efficacy of transdermal nicotine patches (TN) and nicotine nasal spray (NS) in smokers with protective and predisposing *SLC6A3* genotypes. However, the long term health outcomes and costs of care associated with these strategies are not known.

To address this important gap, the investigators will use cost-effectiveness analysis to examine outcomes and costs of three strategies for smoking cessation: 1) the strategy of using counseling and transdermal nicotine patches for all smokers making a quit attempt; 2) using counseling and nicotine nasal spray for all smokers attempting to quit; and 3) testing all smokers making a quit attempt, and tailoring treatment such that those with *SLC6A3*-9 (protective) genotypes receive counseling and transdermal nicotine, and those with *SLC6A3*-* (predisposing) genotypes receive counseling and nicotine nasal spray. Specifically, we aim to:

- 1) To collect quality of life data, measured by health preferences, from participants of a randomized clinical trial of nicotine nasal spray versus transdermal nicotine patches to test the hypothesis that successful quitters have higher health-related quality of life than those making unsuccessful quit attempts, and
- 2) To perform a cost-effectiveness analysis incorporating costs, longevity, and quality of life to test the hypothesis that using *SLC6A3* gene testing to tailor nicotine replacement therapy will be cost-effective compared to treatment of all smokers with either TN or NS. This cost-effectiveness analysis will examine outcomes and cost in terms of the intermediate outcomes of cost per successful quit, and in terms of long-term outcomes of cost per quality-adjusted life year (QALY) saved.

The major strength of this proposal is the development of a mathematical model of the longevity, quality of life, and health care costs for a simulated cohort of smokers which can extend findings from primary data collection. For instance, no clinical trial of smoking cessation interventions has followed the trial cohort until death to determine the effects of the interventions on longevity; such a longitudinal trial would not be feasible. In such situations, simulation modeling can be used to extend the scope of the analysis to populations, settings, and time horizons. This model allows a unique and innovative approach to assessment of the new technology of *SLC6A3* gene testing, allowing for rapid translation from a state-of-the-art clinical trial to clinical practice, should the costs of providing this technology be justified by its potential for benefit. In addition, we evaluate the outcomes for a new nicotine delivery system using nasal spray, comparing the costs and outcomes of this new technology to those of the current standard of therapy. Data from this proposal will provide a framework for clinical management guidelines and health policy decisions that maximize the health of the smoking population for an acceptable cost.

2. Background and Significance

2.1. Nicotine Replacement Therapy: Smoking cessation and prevention strategies hold tremendous potential to improve public health (Surgeon General, 1989). Over 47 million adults in the United States smoke, and smoking now accounts for over 400,000 deaths per year (Surgeon General, 1990). While over 70% of smokers would like to quit smoking (Gallup and Newport, 1990), less than 5% of self-quitters successfully stop smoking 6 months or more (Cohen, et al., 1989), and those in smoking cessation programs incorporating nicotine replacement products only offer 10-30% quit rates (Fiore, et al., 1994; Silagy, et al., 1994; Orleans, et al., 1994). With the high burden of smoking-associated morbidity and mortality, and the low success rates of smoking cessation programs, treatment tailoring based upon genetic predisposition has the potential to produce

CONTINUATION PAGE: STAY WITHIN MARGINS INDICATED

Project 5: Cost-Effectiveness of Different Approaches to Smoking Cessation**PIs: William Lawrence, M.D., Wenchi-Liang, Ph.D.****Specific Aims**

Smoking is a major cause of morbidity and mortality in the United States. While many current smokers are interested in quitting, actual quit rates either with or without pharmacologic therapy are poor for the smoking population as a whole. Recently, the FDA approved the use of sustained-release bupropion for smoking cessation. Given the magnitude of smoking-related health problems, any therapy which improves quit rates has potential for enormous public health benefit. Bupropion has been shown to improve 1-year quit rates, but the of using this therapy on long-term health outcomes and costs of care for smokers is not known.

To address this important gap, the investigators will use cost-effectiveness analysis to examine outcomes and costs of using bupropion in addition to the non-pharmacologic cessation strategies recommended in the recent Agency for Health Care Policy and Research (AHCPR) smoking cessation guidelines, both compared to the non-pharmacologic strategies alone and to nicotine replacement therapy. Specifically we aim:

- 1) To collect quality of life data from current and former smokers to test the hypothesis that former smokers have higher health-related quality of life than current smokers, and
- 2) To perform a cost-effectiveness analysis incorporating costs, longevity, and quality of life to test the hypothesis that using bupropion as an adjunct to non-pharmacologic cessation strategies is cost-effective compared to non-pharmacologic therapy alone and compared to nicotine replacement therapy.

Background and Significance

Smoking cessation and prevention strategies hold tremendous potential to improve public health¹. Over 47 million adults in the United States smoke, and smoking now accounts for over 400,000 deaths per year². While over 70% of smokers would like to quit smoking³, less than 5% of self-quiters successfully stop smoking 6 months or more⁴, and those in smoking cessation programs incorporating nicotine replacement products only offer 10-30% quit rates^{5,6,7}. With the high burden of smoking-associated morbidity and mortality, and the low success rates of smoking cessation programs, any intervention, such as bupropion, which is effective in increasing smoking cessation rates has the opportunity to produce a large public health benefit.

Several antidepressant medications have recently been found to improve quit rates, even for smokers who are not depressed^{8,9,10}. Short-term treatment with sustained-release bupropion (Zyban, Glaxo Wellcome) at a dose of 300 mg. per day was found to almost double the quit rate at one year compared to placebo¹¹. While bupropion has been shown to be effective in increasing quit rates, the cost-effectiveness of using bupropion is not known. This study will determine whether the use of bupropion improves health outcomes at a reasonable societal cost compared to other current cessation interventions. Other therapies in smoking cessation have been shown to be cost-effective, however, suggesting that use of bupropion could be. Nicotine patch therapy has been found to have an incremental cost-effectiveness ratio of \$1,600 to \$11,000 per life year saved^{12,13} compared to counseling alone; these cost-effectiveness ratios are well within the range of values considered "cost-effective". Cromwell and investigators¹⁴ found that following the AHCPR guidelines for smoking cessation, which include both counseling and nicotine replacement therapy, was cost-effective.

Pilot Study Design and Analysis

CONTINUATION PAGE: STAY WITHIN MARGINS INDICATED

AA

Department of Health and Human Services
Public Health Service

LEAVE BLANK--FOR PHS USE ONLY.

Grant Application

Follow instructions carefully.
Do not exceed character length restrictions indicated on sample.

Type	Activity	Number
Review Group	Formerly	
Council/Board (Month, Year)	Date Received	

1. TITLE OF PROJECT (Do not exceed 56 characters, including spaces and punctuation.)
Chemotherapy Outcomes for the Elderly Off & On Trial

2. RESPONSE TO SPECIFIC REQUEST FOR APPLICATIONS OR PROGRAM ANNOUNCEMENT NO YES (If "Yes," state number and title)
Number: PA-99-058 Title: DCTC Clinical Trials Cooperative Groups: Cancer in the Elder

3. PRINCIPAL INVESTIGATOR/PROGRAM DIRECTOR

3a. NAME (Last, first, middle) Mandelblatt, Jeanne	3b. DEGREE(S) M.D.	3c. SOCIAL SECURITY NO. Provide on Form Page KK.
3d. POSITION TITLE Director, Cancer and Aging Research	3e. MAILING ADDRESS (Street, city, state, zip code) Lombardi Cancer Center 2233 Wisconsin Ave, Ste.430 Washington DC 20007	
3f. DEPARTMENT, SERVICE, LABORATORY, OR EQUIVALENT Lombardi Cancer Center		
3g. MAJOR SUBDIVISION Cancer Prevention and Control		
3h. TELEPHONE AND FAX (Area code, number and extension) TEL: 202-687-0812 FAX: 202-687-0305	E-MAIL ADDRESS: mandelbj@gunet.georgetown.edu	

4. HUMAN SUBJECTS <input checked="" type="checkbox"/> No <input checked="" type="checkbox"/> Yes	4a. If "Yes" Exemption no. or IRB approval date Pending	4b. Assurance of compliance no. M-1255	5. VERTEBRATE ANIMALS <input checked="" type="checkbox"/> No <input type="checkbox"/> Yes	5a. If "Yes" IACUC approval date	5b. Animal welfare assurance no.
--	--	---	---	----------------------------------	----------------------------------

6. DATES OF PROPOSED PERIOD OF SUPPORT (month, day, year--MM/DD/YY) From 04/01/2000 Through 03/30/2005	7. COSTS REQUESTED FOR INITIAL BUDGET PERIOD 7a. Direct Costs (\$) 134,738	8. COSTS REQUESTED FOR PROPOSED PERIOD OF SUPPORT 7b. Total Costs (\$) 208,957 8a. Direct Costs (\$) 705,213 8b. Total Costs (\$) 1,098,898
---	---	--

9. APPLICANT ORGANIZATION Name Georgetown University Address 37th & O Streets, NW Washington, DC 20057	10. TYPE OF ORGANIZATION Public: <input type="checkbox"/> Federal <input type="checkbox"/> State <input type="checkbox"/> Local Private: <input checked="" type="checkbox"/> Private Nonprofit Forprofit: <input type="checkbox"/> General <input type="checkbox"/> Small Business	11. ORGANIZATIONAL COMPONENT CODE 01
	12. ENTITY IDENTIFICATION NUMBER 1-53-019-6603-A1 DUNS NO. (if available)	Congressional District DC

13. ADMINISTRATIVE OFFICIAL TO BE NOTIFIED IF AWARD IS MADE Name Val McFerrin Title Grants Officer Address Suite 177, Building D 4000 Reservoir Road, N.W., Washington, DC 20007 Telephone 202 687-1366 FAX 202 687-8263 E-Mail mcferrinv@odrge.odr.georgetown.edu	14. OFFICIAL SIGNING FOR APPLICANT ORGANIZATION Name William J. Hartman Title Director, Research & Technology Development Address 4000 Reservoir Rd., NW Building D, Suite 177 Washington, DC 20007 Phone (202)687-1390 (202)687-8263 FAX hartmanj@odrge.odr.georgetown.edu E-Mail Address
--	---

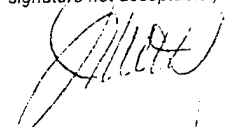
15. PRINCIPAL INVESTIGATOR/PROGRAM DIRECTOR ASSURANCE I certify that the statements herein are true, complete and accurate to the best of my knowledge. I am aware that any false, fictitious, or fraudulent statements or claims may subject me to criminal, civil, or administrative penalties. I agree to accept responsibility for the scientific conduct of the project and to provide the required progress reports if a grant is awarded as a result of this application.	SIGNATURE OF PI / PD NAMED IN 3a. (In ink. "Per" signature not acceptable.) 	DATE 5/20/99
---	---	-----------------

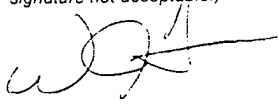
16. APPLICANT ORGANIZATION CERTIFICATION AND ACCEPTANCE: I certify that the statements herein are true, complete and accurate to the best of my knowledge, and accept the obligation to comply with Public Health Service terms and conditions if a grant is awarded as a result of this application. I am aware that any false, fictitious, or fraudulent statements or claims may subject me to criminal, civil, or administrative penalties.	SIGNATURE OF OFFICIAL NAMED IN 14. (In ink. "Per" signature not acceptable.) 	DATE 5/17/99
--	--	-----------------

The Institute of Medicine recently identified under use of chemotherapy is one of the key problems in the quality of cancer care. The randomized clinical trial (RCT) proposed in this CALGB project is designed to begin to address this issue by comparing standard chemotherapy to a new, potentially less toxic, regimen using capecitabine. This companion project will use the defined population of women eligible for the RCT **to compare the quality of life and satisfaction with treatment of 350 women treated off-trial and 350 treated within the RCT**. Standardized telephone interviews will be used to collect data at baseline and 6, 12, 18, and 24 months post-enrollment and records will be reviewed for clinical information. The aims of the study are: 1) To compare quality of life outcomes and satisfaction with treatment of women receiving chemotherapy off and on trial, controlling for local and systemic treatment, comorbidity, age, and other covariates; 2) To describe disease-free survival and competing causes of mortality; and 3) To evaluate predictors of RCT participation.

This companion proposal represents a novel opportunity to assess the effects of chemotherapy delivered in an RCT compared to usual care in a defined population of elderly women with breast cancer eligible for a chemotherapy RCT. Given that the average 80 year old woman with local or regional disease has a life expectancy of more than nine years and has a fair (>30%) probability of relapse in her life time, increased use of chemotherapy has the potential to decrease morbidity, and perhaps, mortality from this disease.

DESCRIPTION. State the application's broad, long-term objectives and specific aims, making reference to the health relatedness of the project. Describe concisely the research design and methods for achieving these goals. Avoid summaries of past accomplishments and the use of the first person. This description is meant to serve as a succinct and accurate description of the proposed work when separated from the application. If the application is funded, this description, as is, will become public information. Therefore, do not include proprietary/confidential information. **DO NOT EXCEED THE SPACE PROVIDED.**

The elderly, who represent half of the 185,000 new cases of breast cancer and two-thirds of the deaths, have failed to realize any of the benefits of recent mortality reductions seen among younger women. At present, over 40% of the elderly women diagnosed each year will have regional stages of disease, where chemotherapy can have survival benefits. However, actual chemotherapy treatment patterns diverge from consensus recommendations for the elderly. Patient preferences or strong comorbidities may be legitimate reasons to omit chemotherapy, while age would not. At present, we do not understand the reasons for the variations in practice among the elderly. Even with the recent National Institute of Aging and National Cancer Institute announcement for research in the elderly, it is unlikely that large scale randomized trials of broad elderly groups will be mounted in the near future to address this gap. Thus, Lombardi Cancer Center and the Cancer and Leukemia Group B (CALGB) propose to study a **large prospective, longitudinal, observational cohort of newly-diagnosed elderly breast cancer patients with regional disease. The primary goals of this project are to use a conceptual model based in preference theory to identify medical, socio-demographic, and psycho-social factors associated with patient preferences, chemotherapy decisions, and subsequent quality of life and satisfaction up to 3 years post-enrollment.** Careful attention will be paid to controlling for important confounders. Data will be collected from 1,300 women 4-6 six weeks after ascertainment in a standardized telephone interview; women will be re-interviewed 6 months, 1, 2 and up to 3 years following study entry. Records will be reviewed for clinical data. The specific goals are: 1) To evaluate factors associated with chemotherapy decisions, including age and comorbidity, and to compare the decisions of Blacks and Whites; 2) To examine the role of chemotherapy decisions in quality of life and satisfaction outcomes, controlling for covariates; 3) To describe the impact of comorbidity on ability to tolerate chemotherapy; and 4) To collect preliminary data on disease-free survival and competing causes of mortality. Large observational studies such as this are an efficient manner to obtain data on treatment decisions, course of therapy, and outcomes in general populations. However, given potential unmeasurable confounding, our results will need to be confirmed in clinical trials. In the interim, these data will fill important knowledge gaps in cancer in the elderly that will be broadly portable to efforts to improve the cancer outcomes of this population. This project will also provide the infrastructure for future CALGB and inter-group companion studies comparing outcomes of women who chose to participate in research protocols and those who seek routine care.

PERFORMANCE SITE(S) (organization, city, state)

Cancer & Leukemia Group B (CALGB) Central Office, Chicago, IL
Georgetown University Medical Center, Washington, DC

KEY PERSONNEL. See instructions on Page 11. Use continuation pages as needed to provide the required information in the format shown below.

Name	Organization	Role on Project
Jeanne Mandelblatt, MD, MPH	Georgetown University Medical Center	Principal Investigator
Daniel Hayes, MD	Georgetown University Medical Center	Co-Investigator
William Lawrence, MD, MSIE	Georgetown University Medical Center	Co-Investigator
Kathryn Taylor, PhD	Georgetown University Medical Center	Co-Investigator
Richard Schilsky, MD	Cancer & Leukemia Group B (CALGB) Central Office	Principal Investigator
Stephen George, PhD	Duke University Medical Center	Principal Investigator
Bercedis Peterson, PhD	Duke University Medical Center	Statistician
Margaret Borwhat, MS	Women's Cancer Advocacy Network	Consultant
Harvey Cohen, PhD	Duke University Medical Center	Consultant
Alice Kornblith, PhD	Memorial Sloan-Kettering Cancer Center	Consultant
Joanne Lamphere, DrPh	American Association of Retired Persons	Consultant
Hyman Muss, MD	Vermont Cancer Center	Consultant
Jane Weeks, MD	Dana-Farber Cancer Institute	Consultant

PROPOSAL COVER BOOKLET

MARKING INSTRUCTIONS

CORRECT MARK ●

INCORRECT MARKS ✓ X ●

• Use a No. 2 pencil for bubbles.

• Type or print in block letters in the non-bubble areas. (ink is acceptable.)

• Make solid marks that fill the circle completely.

• Make no stray marks on this form.

• Do not fold or tear this form.

1. Proposal Log Number (Leave blank.)

2. BAA Identifier and Proposal Category

ECRP-99, Idea Award

3. Proposal Category Code

(Enter the Proposal Category Code from the list provided in the Proposal Cover Booklet Instructions. Must agree with Proposal Category listed in question #2.)

1	1
2	2
3	3
4	4
5	5
6	6
7	7
8	8
9	9
0	0

4. Organization Code (Leave blank.)

1	2	3	4	5
6	7	8	9	0
1	2	3	4	5
6	7	8	9	0
1	2	3	4	5
6	7	8	9	0
1	2	3	4	5
6	7	8	9	0
1	2	3	4	5
6	7	8	9	0

5. Organization Name and Grants/Contracts Office Address

Organization Name: Georgetown University
 Street Address: Suite 177 Bldg. D
4000 Reservoir Rd NW
 City: Washington State: DC
 Country: USA Zip Code: 20007

6. Type of Organization (Enter the Type of Organization from the list provided in the Proposal Cover Booklet Instructions.)

E A B C D E F ● G H I J K L M N O P Q R S T U V W X Y Z

7. Principal Investigator

Last Name	First Name	MI
<u>Marcelo</u>	<u>Jeanne</u>	<u>S</u>

ABX bubble grid for automated data entry.



PLEASE DO NOT WRITE IN THIS AREA

30623

11. PI Address—Department Name (If none, leave blank. Use spaces as appropriate.)

Cancer and Aging Research

A
 B
 C
 D
 E
 F
 G
 H
 I
 J
 K
 L
 M
 N
 O
 P
 Q
 R
 S
 T
 U
 V
 W
 X
 Y
 Z
 0
 1
 2
 3
 4
 5
 6
 7
 8
 9



PLEASE DO NOT WRITE IN THIS AREA

30623

14. PI Address

City

Washington

Alphabetical grid for address entry with filled bubbles for 'Washington'.

15. PI Address

State

DC

Alphabetical grid for state entry with filled bubbles for 'DC'.

16. PI Address

Country

US

Alphabetical grid for country entry with filled bubbles for 'US'.

17. PI Address—Zip Code (Non-U.S. codes write in below.)

20007-

Grid for zip code entry with filled bubbles for '20007'.

International Postal Code

18. Principal Investigator's Phone Number (U.S. and Canada only. If you have an International Phone Number, please write in the number, starting with country code, below.)

202-687-0812

Grid for phone number entry with filled bubbles for '202-687-0812'.

International Phone Number

19. Principal Investigator's Fax Number (U.S. and Canada only. If you have an International Fax Number, please write in the number, starting with country code, below.)

Area Code

202	687	0305
0 0 0	0 0 0	0 0 0
1 1 1	1 1 1	1 1 1
2 2 2	2 2 2	2 2 2
3 3 3	3 3 3	3 3 3
4 4 4	4 4 4	4 4 4
5 5 5	5 5 5	5 5 5
6 6 6	6 6 6	6 6 6
7 7 7	7 7 7	7 7 7
8 8 8	8 8 8	8 8 8
9 9 9	9 9 9	9 9 9

International Fax Number

20. Principal Investigator's E-Mail Address (If available.)

mandeibj@gunet.georgetown.edu

21. Principal Investigator Demographics (Optional.)

Gender: Male Female

Ethnicity: (Select one)
American Indian Hispanic or Latino
Alaska Native Native Hawaiian or Other Pacific Islander
Asian White
Black or African American Other (Specify): _____

22. Key Personnel Demographics (Optional, select all that apply.)

Gender: Male Female

Ethnicity:
American Indian Hispanic or Latino
Alaska Native Native Hawaiian or Other Pacific Islander
Asian White
Black or African American Other (Specify): _____

23. Proposal Title (This may be up to 160 characters long.)

Aging, Gene, and Environment Interactions in the Risk of Having Breast Cancer

24. Total Funding Requested from the Government (Direct and Indirect Costs) for the Entire Proposed Period of Research (Whole U.S. dollar figures ONLY. Enter number flush with right-hand margin.)

\$	3	4	8	1	0	6	
0	0	0	0	0	0	0	0
1	1	1	1	1	1	1	1
2	2	2	2	2	2	2	2
3	3	3	3	3	3	3	3
4	4	4	4	4	4	4	4
5	5	5	5	5	5	5	5
6	6	6	6	6	6	6	6
7	7	7	7	7	7	7	7
8	8	8	8	8	8	8	8
9	9	9	9	9	9	9	9

25. Military/Civilian Collaboration (Mark the appropriate statement. If your proposal DOES represent a Military/Civilian Collaboration, fill in the full name of the Collaborating Organization.)

The proposed work DOES represent a Military/Civilian Collaboration. (Complete the following.)

Collaborating Organization: _____

Collaborating Organization Address: _____

The proposed work DOES NOT represent a Military/Civilian Collaboration.

26. Human Subjects

In the proposed work, will Human Subjects be used? Yes No

If yes, which Human Subjects will be used? (Select all that apply.)

- Minorities
- Military, Active Duty
- Military, Reserve
- National Guard
- Foreign
- Inpatient
- Outpatient
- Other (Specify): _____

27. Human Anatomical Substances

In the proposed work, will Human Anatomical Substances be used? Yes No

If yes, which Human Anatomical Substance(s) will be used? (Select all that apply.)

- Blood
- Cells
- DNA
- Established Cell Lines
- Primary Cell Lines
- Saliva
- Tissue
- Urine
- Other (Specify): _____

Can the Human Anatomical Substance(s) indicated above be traced to a specific donor? Yes No

28. Clinical Trials

Does the proposed work include Clinical Trials? Yes No

If yes, select the type of Clinical Trial(s) proposed (Select all that apply.)

- Investigational Drugs
- Investigational Devices
- Approved Drugs
- New Indications for Approved Drugs



PLEASE DO NOT WRITE IN THIS AREA

30623

29. Demographics of Human Test Subjects/Study Population of Interest

Does your research specifically target any particular segment of the population?

- Yes
- No
- Not applicable

If yes, please answer the following questions:

A. Gender of the Human Test Subjects/Study Population

Does your research *specifically target* any of the following categories?

- Male
- Female
- No target

B. Ethnicity of the Human Test Subjects/Study Population

Does your research *specifically target* any of the following ethnic/racial categories?

- | | |
|---|---|
| <input type="radio"/> American Indian | <input type="radio"/> Native Hawaiian or Other Pacific Islander |
| <input type="radio"/> Alaska Native | <input type="radio"/> White |
| <input type="radio"/> Asian | <input type="radio"/> Other (Specify): _____ |
| <input type="radio"/> Black or African American | <input checked="" type="radio"/> No target |
| <input type="radio"/> Hispanic or Latino | |

C. Age of the Human Test Subjects/Study Population

Does your research *specifically target* any of the following age ranges?

- | | |
|---|---|
| <input type="radio"/> Minor (under 18 years of age) | <input checked="" type="radio"/> 51-70 years of age |
| <input type="radio"/> 13-30 years of age | <input checked="" type="radio"/> Over 70 years of age |
| <input type="radio"/> 31-50 years of age | <input type="radio"/> No target |

D. General Income of the Human Test Subjects/Study Population

Does your research *specifically target* any of the following categories?

- Low income (less than \$30,000/year)
- Middle income (\$31,000-\$45,000/year)
- Upper income (greater than \$45,000/year)
- No target

E. General Demographic Target or Focus

Does your research *specifically target* any of the following categories?

- Underserved population(s)
- Underserved population(s)
- No target

33. Research Classification (Enter the Classification Code from the list provided in the Proposal Cover Booklet Instructions.)

40
 0
 1
 2
 3
 4
 5
 6
 7
 8
 9

34-38. Research Area (Enter the codes from the list provided in the Proposal Cover Booklet Instructions.)

34. Research Area Level 1

0217
 0
 1
 2
 3
 4
 5
 6
 7
 8
 9

35. Research Area Level 2

0257
 0
 1
 2
 3
 4
 5
 6
 7
 8
 9

36. Research Area Level 3

2300
 0
 1
 2
 3
 4
 5
 6
 7
 8
 9

37. Research Area Level 4

0000
 0
 1
 2
 3
 4
 5
 6
 7
 8
 9

38. Research Area Level 5

0
 1
 2
 3
 4
 5
 6
 7
 8
 9

39. Have you submitted another proposal in a different Proposal Category? (Do not include Proposals submitted to other programs or for previous years.)

Yes No

If yes, please enter the Proposal Category Code from the list provided for question #3 in the Proposal Cover Booklet Instructions.

0
 1
 2
 3
 4
 5
 6
 7
 8
 9

40. Administrative Representative Authorized to Conduct Negotiations. (Signature MANDATORY.)

Primary Contact
Name: William J. Hartman
Department: Research and Technology Development Services
Telephone Number: 202-687-1390
Fax Number: 202-687-8263
E-Mail Address: hartmanj@odrge.odr.georgetown.edu
Signature: [Signature] Date: 5/25/99

Secondary Contact
Name: William J. Hartman
Department: Research and Technology Development Services
Telephone Number: 202-687-1390
Fax Number: 202-687-8263
E-Mail Address: hartmanj@odrge.odr.georgetown.edu
Signature: [Signature] Date: 5/25/99

41. Institution's Official Proposal Control Number (If none, leave blank.)

[Empty box for Institution's Official Proposal Control Number]

42. Principal Investigator (Must match PI listed in question 7. Signature MANDATORY.)

Name: Jeanne S. Mandelblat, MD, MPH
Department: Lombardi Cancer Center
Signature: [Signature] Date: 5-19-99



**PROPOSAL SUBMITTED IN RESPONSE
TO THE BROAD AGENCY ANNOUNCEMENT
FOR
1999 BREAST CANCER PROGRAM**

**UNITED STATES ARMY MEDICAL RESEARCH
AND MATERIEL COMMAND**

PEER REVIEW REFERRAL PAGE

PROPOSAL TITLE: "Aging, Gene, Environment Interactions in the Risk of Having Breast Cancer"

PRINCIPAL INVESTIGATOR: *(full name including middle initial)*
Jeanne S. Mandelblatt, MD, MPH

KEYWORD DESCRIPTIVE TECHNICAL TERMS:
Breast Cancer, Aging, Gerontology, Telomerase, DNA Repair, Genetics

CONFLICT OF INTEREST CONSIDERATIONS: KEY PERSONNEL

NAME	DEGREE	DISCIPLINE	INSTITUTION	TITLE	ROLE
Jeanne Mandelblatt	MD, MPH	Geriatrics, Health Services, Epidemiology	Lombardi Cancer Center (LCC)	Associate Professor	PI
Bruce Trock	PhD	Molecular Epidemiology	"	Associate Professor	Co-Investigator
Robert Dickson	PhD	Cell Biology	"	Professor	Co-Investigator
Baljit Singh	MD	Pathology	Georgetown Univ Medical Center	Assistant Professor	Co-Investigator
Lodovico Balducci	MD	Oncology	H. Lee Moffitt Cancer Center	Program Leader	External Advisor
Margaret Borwhat	MS	Advocate	Women's Cancer Advocacy Network	Director	External Advisor
William Ershler	MD	Oncology/Basic Science	Institute for Advanced Studies in Aging and Geriatric Medicine	Director	External Advisor

**PROPOSAL SUBMITTED IN RESPONSE
TO THE BROAD AGENCY ANNOUNCEMENT
FOR
1999 BREAST CANCER PROGRAM**

**UNITED STATES ARMY MEDICAL RESEARCH
AND MATERIEL COMMAND**

PROPOSAL TITLE: "Aging, Gene, Environment Interactions in the Risk of Having Breast Cancer"

AWARD CATEGORY: *(indicate re-submission@ if appropriate)* IDEA Award

PRINCIPAL INVESTIGATOR: *(full name including middle initial)*

Jeanne S. Mandelblatt, MD, MPH

PHONE: (202) 687-0812

FAX: (202) 687-0305

ORGANIZATION: GEORGETOWN UNIVERSITY
LOMBARDI CANCER CENTER
37th and O Streets, NW
WASHINGTON, D.C. 20007
USA

CONTRACTING

REPRESENTATIVE: William J. Hartman

PHONE: (202) 687-1390

FAX: (202) 687-8263

PROPOSED START DATE: July 1, 2,000

TECHNICAL ABSTRACT

PROPOSAL TITLE: "Aging, Gene, Environment Interactions in the Risk of Having Breast Cancer"
PRINCIPAL INVESTIGATOR: Jeanne Mandelblatt, MD, MPH

In 1999, 185,000 women will develop breast cancer, and more than 43,000 will die of their disease. Almost 50% of these new cases and nearly two-thirds of the deaths will occur among the 13% of the female population that is aged 65 or more (hereinafter referred to as elderly). The elderly are also the fastest growing segment of the US population today; it is projected that by the year 2030, one in five women will be elderly. Thus, elderly women will account for an increasing absolute number of breast cancer cases in the next millennium. Despite these impressive biological and demographic profiles, little is known about the causes of breast cancer in the elderly. With few exceptions, the majority of research on cancer biology has been conducted in non-elderly populations. Indeed, until recently, the elderly have been excluded from cancer clinical trials and research protocols.

At present, we do not know how environmental, genetic, and aging processes might interact to produce the exponential increases in cancer risk seen with advancing age. Several environmental and genetic processes have been associated with the risk of having or developing breast cancer, including oxidative damage, faulty DNA repair, hormonal milieu, and p53, erb-B-2, and BRCA1/2 genetic mutations. Another potential risk factor for developing cancer may involve telomerase, where lack of inhibition of telomerase activity can lead to cell immortalization. Telomerase activity is also related to many processes of aging, including cell death, making it an interesting candidate marker for age-mediated carcinogenesis.

To begin to address gaps in our understanding of age-related components in the etiology of breast cancer, we are proposing to conduct a case-control study of 350 women newly diagnosed older women ages 40 and older with BRCA1/2 negative breast cancer and 350 controls with a negative breast biopsy to evaluate the roles of age, traditional risk factors, diet, oxidative damage, DNA repair, p53, erbB2, and telomerase activity in the risk of being diagnosed with cancer; we will also compare risks seen in older and younger cancer cases. This proposal builds on the nationally renowned breast cancer program at Lombardi Cancer Center, strong collaborative relationships, a solid infrastructure to support tissue and serum analyses, and a core of nationally recognized scientific and consumer advisors.

This proposal is innovative in its use of a multi disciplinary team focusing on an under-studied population- older women - and the application of state-of-the-art molecular genetics and histopathology techniques to explore previously unaddressed research questions. Data from this project will serve as a platform for future interventions to prevent breast cancer. In addition, the data on the risk of disease will also serve as a model for studying age-related response to treatment and prognosis. This type of research has the promise to ensure that scientific insights are translated from the laboratory into new research and clinical care paradigms for future generations of breast cancer patients.

PUBLIC ABSTRACT

PROPOSAL TITLE: "Aging, Gene, Environment Interactions in the Risk of Having Breast Cancer"
PRINCIPAL INVESTIGATOR: Jeanne Mandelblatt, MD, MPH

Cancer is a disease of the aged. In 1999, 185,000 women will develop breast cancer, and more than 43,000 will die of their disease. Nearly 50% of these new cases and nearly two-thirds of the deaths will occur among the 13% of the female population that is aged 65 or more; the median age of women with breast cancer is 70. The elderly are also the fastest growing segment of the US population today; it is projected that by the year 2030, one in five women will be elderly. Thus, elderly women will account for an increasing absolute number of breast cancer cases in the next millennium. Despite these impressive biological and demographic profiles, little is known about the causes of breast cancer in the elderly. With few exceptions, the majority of research on cancer biology has been conducted in non-elderly populations. Indeed, until recently, the elderly have been excluded from cancer clinical trials and research protocols.

Thus, at present, we do not know how putative environmental, genetic, and aging processes might interact to produce the exponential increases in cancer risk seen with advancing age. Is there a simple cumulative effect of cell damage over time? Are there specific gene-environment interactions that occur in an aging host? Do normal aging processes, such as programmed cell death, become repressed in the presence of oncogenes? Do older women with breast cancer have different distributions of biomarkers than younger cases?

To begin to address these critical questions, we are proposing to conduct a case-control study of 350 women newly diagnosed women 40 years with BRCA1/2 negative breast cancer and 350 controls with a negative breast biopsy to evaluate the roles of age, traditional risk factors, diet, oxidative damage, DNA repair, p53, and telomerase activity in the risk of being diagnosed with cancer; we will also compare the distribution of biomarkers in younger and older cases. This proposal builds on the nationally renowned breast cancer program at Lombardi Cancer Center, strong collaborative relationships, a solid infrastructure to support tissue and serum analyses, and a core of nationally recognized scientific and consumer advisors.

This proposal is innovative in its use of a multi disciplinary team focusing on an under-studied population- older women - and the application of state-of-the-art molecular genetics and histopathology techniques to explore previously unaddressed research questions. Data from this project will serve as a platform for future interventions to prevent breast cancer. In addition, the data on the risk of disease will also serve as a model for studying age-related response to treatment and prognosis. This type of research has the promise to ensure that scientific insights are translated from the laboratory into new research and clinical care paradigms for future generations of breast cancer patients.

Liang, W
Last name, first initial of Principal Investigator
POP99-003028

Komen I.D. #

SUSAN G. KOMEN BREAST CANCER FOUNDATION REQUEST FOR FUNDING FOR POPULATION SPECIFIC BREAST CANCER PROJECT

Principal Investigator: Wenchi Liang, Ph.D.
(Please indicate degree)

Title: Senior Research Associate

Institution: Georgetown University Medical Center, Lombardi Cancer Center,
Division of Cancer Prevention and Control

Address: 2233 Wisconsin Ave, NW, Suite 430

Washington, D.C. 20007

Phone: (202) 687-8937

Fax: (202) 687-0305

Email: Liangw@gunet.georgetown.edu

Please note: ALL correspondence will be addressed to the Principal Investigator at the address above.

Total amount requested: \$ 150,000.00

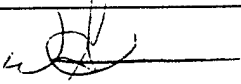
Approving institutional official:  3/25/99
Signature Date

Printed name and title of institutional official: William J. Hartman
Director
Printed name Title

Title of Project: The impact of physician-patient communication on the use of
screening mammography among the elderly

Target Population: Elderly women age 65 and older in the Metropolitan D.C. area

Subject Category Code: 4 Screening

(see code sheet, use only one code)

Komen office use only:	Committee Assignment: _____ Rating: _____
-------------------------------	--

(Photocopies of this form are acceptable.)

Grant: POP99

ABSTRACT

Please provide a short abstract, not to exceed 200 words, written in lay terms for release to the general public if this application is chosen for funding.

The Impact of Physician-Patient Communication on the Use of Screening Mammography Among The Elderly

Breast cancer is the most commonly diagnosed cancer and the second leading cause of cancer-related death among American women. Despite mammography's preventive value, elderly women underuse mammography. Doctors' recommendation is considered to be the most important factor for mammography use, but elderly patients receive less conversation time from their physicians than younger patients. Little is known about whether and how physician-patient communication affect elderly women's screening behavior.

To fill this gap in knowledge, we will examine and assess the role of physician-patient communication on elderly patients' mammography use. Female patients age 65 or older who are due for a mammogram in 6 months will be invited to participate. Actual communication will be audiotaped and analyzed. Patients' intention for a mammogram and actual mammography use during the follow-up period will be compared against communication styles. We expect that most elderly women play a passive role on communication, and a participatory communication style which encourages elderly women's involvement in discussion will significantly predict mammography use.

This research will contribute to theories linking communication and behavioral outcomes, and provide the scientific basis for future physician training and interventions to increase mammography use in our aging population with a high burden of illness.

Permission to publish:

Permission is hereby given to the Susan G. Komen Breast Cancer Foundation to publish the above abstract if this application is selected for funding.

Signature

Wenchi Liang

Date

3-22-99

Printed name

Wenchi Liang



GEORGETOWN UNIVERSITY MEDICAL CENTER

LOMBARDI CANCER CENTER
Research • Education • Treatment

The Impact of Physician-Patient Communication on the use of Screening Mammography Among the Elderly

Primary Investigator Name: Wenchi Liang, D.D.S., Ph.D.
Title/Position: Senior Research Associate
Cancer Clinical and Economic Outcomes Core
Division of Cancer Prevention and Control
Lombardi Cancer Center
Georgetown University Medical Center

[Redacted]

Telephone Number: 202-687-8937

Facsimile Number: 202-687-0305

PII Redacted

Co-Investigators: Jeanne S. Mandelblatt, M.D., M.P.H.
Kathryn Taylor, Ph.D.

Amount of Funds Requested: \$20,000

Duration of Research Study: 24 months

Location of Research: Georgetown University Medical Center
George Washington University Medical Center

I understand that the information relating to my research project contained in or transmitted with this Application is for the purpose of enabling the Bayer Institute to evaluate and consider my proposal for funding for the 1999 research grants.

Wenchi Liang 3-15-99
Applicant Signature Date

Marc E. Lippman, M.D. Director Lombardi Cancer Center
Name and title of official representing the institution

M. E. Lippman 3/15/99
Signature Date



TITLE: **The impact of physician-patient communication on the use of screening mammography among the elderly**

ABSTRACT:

Breast cancer is the most commonly diagnosed cancer and the second leading cause of cancer-related death among American women. Despite the proven value of mammography in reducing mortality from breast cancer, numerous reports show that elderly women receive mammography less often than other women. Medical visits and information from physicians significantly predict mammography use for all women, but elderly women are less likely to receive a physician recommendation for screening than younger women. Elderly patients generally take a passive role during medical visits, and receive less conversation time from their physicians than younger patients. Physician-patient communication and styles of communication have been shown to affect patients' satisfaction with care and compliance to medication, but there is a paucity of literature on communication in the elderly, and none that we are aware of that address the role of physician-patient communication on mammography use. It is highly possible that a participatory communication style which encourages elderly women's involvement in discussion will significantly increase elderly women's mammography use and satisfaction with care.

To fill this gap in knowledge and test this hypothesis, we use a conceptual framework to design and evaluate a prospective longitudinal study to examine preferred and actual communication styles between physicians and elderly female patients, and assess the role of communication on patients' subsequent mammographic screening behaviors. Female patients age 65 or older who are due for a mammography in 6 months will be accrued during a routine medical visit and asked to complete a questionnaire before and immediately after the visit; the follow-up telephone survey to assess actual behavior will be completed 9 months after the visit. Physicians' preferred styles of communication will also be assessed before actual communication. Physician-patient communication during the clinical encounter will be audio-recorded and coded by trained assistants. Patients' intention for a future mammogram will be assessed by self-report after the visit, and actual mammography screening behavior will be acquired from the telephone interview. The specific aims and hypotheses of the proposed research are:

1. To describe elderly women's self-reported preferred styles of physician-patient communication and to identify the determinants of preferences for communication;
2. To evaluate actual communication styles during medical encounters and the degrees to which patients' and physicians' characteristics influence communication;
3. To evaluate the impact of communication styles on elderly women's (a) intention to get a mammogram, (b) actual screening behavior in a 9-month follow-up period, and (c) satisfaction with care.

This proposed research will make important scientific, clinical, and policy contributions. First, knowledge about how interactions between elderly women and their physicians influence mammography use can contribute to theories linking communication, decision-making, and psychological and behavioral outcomes in a growing population with a high burden of illness. Second, information about desirable communication styles will be useful to physicians and health care organizations in enhancing clinical skills and quality of care. Third, the results can provide the scientific basis for future physician training and interventions to increase mammography use among the elderly in our aging society.

Attachment 2

1999 MERCK & CO., INC. QUALITY CARE RESEARCH FUND
PROPOSAL COVER SHEET

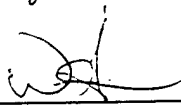
TITLE OF PROJECT	Burden of Colorectal Cancer in a Managed Care Population
PRINCIPAL INVESTIGATOR	John L. Marshall, MD
POSITION TITLE	Assistant Professor of Medicine
ORGANIZATION	Lombardi Cancer Center
ADDRESS	P Lombardi Georgetown University Medical Center 3800 Reservoir Rd Washington, DC 20007
PHONE NUMBER	(202) 687-2198
FAX NUMBER	(202) 687-4429
E-MAIL ADDRESS	Marshallj@gunet.georgetown.edu
AMOUNT REQUESTED YEAR ONE / TOTAL	\$ 266,120 / \$ 399,741
DATES OF PROPOSED PROJECT	10/01/99-3/31/01
SUBMITTED IN CATEGORY	<input type="checkbox"/> 1 <input checked="" type="checkbox"/> 2 <input type="checkbox"/> 3
COLLABORATIVE INSTITUTIONS	
SUBMISSION DATE	6/1/99
SIGNATURE OF PRINCIPAL INVESTIGATOR	
SIGNATURE AND TITLE OF OFFICIAL AT FORUM PARTICIPANT INSTITUTION	 William J. Hartman, Director

EXECUTIVE SUMMARY

DESCRIPTION. State the application's broad, **long-term objectives** and **specific aims**, stressing their applied significance, originality, and relevancy to the purpose of the Quality Care Research Fund. Describe concisely the **research design** and **methods** for achieving these goals and the **expected outcome/results**. Avoid summaries of past accomplishments and the use of the first person. This description is meant to serve as a succinct and accurate description of the proposed work when separated from the application. If the application is funded, this description, as is, will become public information. Therefore, do not include proprietary/confidential information. **DO NOT EXCEED 400 WORDS.**

Project Title: Burden of Colorectal Cancer in a Managed Care Population

Colorectal cancer represents a significant burden on individuals, their families, and the medical care system. To date, there has been little work describing the burden of colorectal cancer, or assessing the cost-effectiveness of colon cancer screening and prevention efforts in different health settings and populations. In this project, we propose to form an academic medical center and private non-profit partnership between the Lombardi Cancer Center and Kaiser Permanente Mid-Atlantic States (KPMAS). This multidisciplinary team will conduct a nested case-control study of 1,400 colorectal cancer patients and 1,400 controls to further the knowledge of the burden of colorectal cancer within a defined managed care population. The specific aims of the project are: 1) to describe the burden of colorectal cancer in a managed care population, including the impact on direct health care costs, out-of-pocket costs, quality of life, and satisfaction with care, and to evaluate the most influential factors of disease burden; and 2) to use the data on costs and quality of life to conduct a preliminary cost-effectiveness analysis of the impact of the use of cyclo-oxygenase 2 (COX-2) inhibitors on costs and outcomes from colorectal cancer in managed care settings. To accomplish these aims, we will identify all members of KPMAS entered into their administrative database with the diagnosis of colon or rectal cancer between 1/1/1997 and 12/31/1999, and an age- and sex-matched control for each case. Resource utilization and medical care costs of cases and controls will be determined from the KPMAS database. Eligible cases and controls will be interviewed to determine potential influential factors on burden of care, quality of life, out-of-pocket costs, and satisfaction with care. Quality of life and medical care costs will then be used in an analysis to determine the incremental cost-effectiveness of using COX-2 inhibitors for chemoprophylaxis in this population. This study extends prior work in the field by providing a thorough understanding of the burden of colorectal cancer in managed care settings in terms of direct medical costs, out-of-pocket costs, quality of life, and patient satisfaction. A better understanding of this disease burden will allow more accurate determination of the benefits of colorectal cancer screening and prevention.

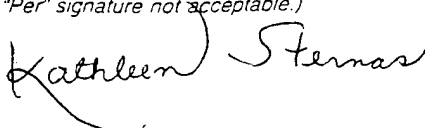
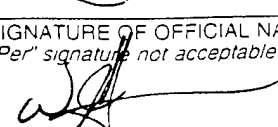
Department of Health and Human Services Public Health Service		LEAVE BLANK—FOR PHS USE ONLY.		
Grant Application <i>Follow instructions carefully. Do not exceed character length restrictions indicated on sample.</i>		Type	Activity	
		Review Group	Formerly	
		Council/Board (Month, Year)		Date Received
		1. TITLE OF PROJECT Breast Cancer: Counseling, Companions and Quality of Life		
2. RESPONSE TO SPECIFIC REQUEST FOR APPLICATIONS OR PROGRAM ANNOUNCEMENT <input type="checkbox"/> NO <input checked="" type="checkbox"/> YES (If "Yes," state number and title) Number: K01 (MRSDA-N) Title: Mentored Research Scientist Development Award - Nursing				
3. PRINCIPAL INVESTIGATOR/PROGRAM DIRECTOR New Investigator <input checked="" type="checkbox"/> YES				
3a. NAME (Last, first, middle) Sternas, Kathleen A.	3b. DEGREE(S) PhD, RN	3c. SOCIAL SECURITY NO. <i>Provide on Form Page KK</i>		
3d. POSITION TITLE Assistant Professor	3e. MAILING ADDRESS (Street, city, state, zip code) Georgetown University School of Nursing Box 571107 3700 Reservoir Rd., NW Washington, DC 20057-1107			
3f. DEPARTMENT, SERVICE, LABORATORY, OR EQUIVALENT School of Nursing				
3g. MAJOR SUBDIVISION School of Nursing				
3h. TELEPHONE AND FAX (Area code, number and extension) TEL: 202-687-7645 FAX: 202-687-5553	E-MAIL ADDRESS: sternask@gunet.georgetown.edu			
4. HUMAN SUBJECTS <input type="checkbox"/> No <input checked="" type="checkbox"/> Yes	4a. If "Yes," Exemption no. or IRB approval date pending	4b. Assurance of compliance no. <input type="checkbox"/> Full IRB or <input checked="" type="checkbox"/> Expedited Review	5. VERTEBRATE ANIMALS <input checked="" type="checkbox"/> No <input type="checkbox"/> Yes	
6. DATES OF PROPOSED PERIOD OF SUPPORT (month, day, year—MM/DD/YY) From: 4/1/2000 Through: 3/31/2003		7. COSTS REQUESTED FOR INITIAL BUDGET PERIOD 7a. Direct Costs (\$) 82,000.	8. COSTS REQUESTED FOR PROPOSED PERIOD OF SUPPORT 8a. Direct Costs (\$) 246,000. 8b. Total Costs (\$) 265,120	
9. APPLICANT ORGANIZATION Name: Georgetown University Address: 37th and O Streets, NW Washington, DC 20057		10. TYPE OF ORGANIZATION Public: <input type="checkbox"/> Federal <input type="checkbox"/> State <input type="checkbox"/> Local Private: <input checked="" type="checkbox"/> Private Nonprofit Forprofit: <input type="checkbox"/> General <input type="checkbox"/> Small Business		
		11. ORGANIZATIONAL COMPONENT CODE 01		
		12. ENTITY IDENTIFICATION NUMBER 1-530196603-A1 DUNS NO. (if available)		
		Congressional District DC		
13. ADMINISTRATIVE OFFICIAL TO BE NOTIFIED IF AWARD IS MADE Name: Trudy Bright Title: Grants and Contracts Administrator Address: Division of Research Grants & Contracts 4000 Reservoir Rd., NW Washington, DC 20007 Telephone: 202-687-1227 Fax: 202-687-8263 E-mail: Bright@ODRGE.ODR.Georgetown.edu		14. OFFICIAL SIGNING FOR APPLICANT ORGANIZATION Name: William Hartman Title: Director of Research & Technology Address: Development Services 4000 Reservoir Rd., NW Washington, DC 20007 Telephone: 202-687-1390 Fax: 202-687-8263 E-mail: Hartman@ODRGE.ODR.Georgetown.edu		
15. PRINCIPAL INVESTIGATOR/PROGRAM DIRECTOR ASSURANCE: I certify that the statements herein are true, complete and accurate to the best of my knowledge. I am aware that any false, fictitious, or fraudulent statements or claims may subject me to criminal, civil, or administrative penalties. I agree to accept responsibility for the scientific conduct of the project and to provide the required progress reports if a grant is awarded as a result of this application.		SIGNATURE OF PI / PD NAMED IN 3a. (In ink. "Per" signature not acceptable.)  DATE: 5/17/99		
16. APPLICANT ORGANIZATION CERTIFICATION AND ACCEPTANCE: I certify that the statements herein are true, complete and accurate to the best of my knowledge, and accept the obligation to comply with Public Health Service terms and conditions if a grant is awarded as a result of this application. I am aware that any false, fictitious, or fraudulent statements or claims may subject me to criminal, civil, or administrative penalties.		SIGNATURE OF OFFICIAL NAMED IN 14. (In ink. "Per" signature not acceptable.)  DATE: 5/27/99		

DESCRIPTION: State the application's broad, long-term objectives and specific aims, making reference to the health relatedness of the project. Describe concisely the research design and methods for achieving these goals. Avoid summaries of past accomplishments and the use of the first person. This description is meant to serve as a succinct and accurate description of the proposed work when separated from the application. If the application is funded, this description, as is, will become public information. Therefore, do not include proprietary/confidential information. DO NOT EXCEED THE SPACE PROVIDED.

>The candidate's long-term career goal is to develop the skills to become an independent nurse-researcher in cancer prevention and control with a primary focus on testing intervention strategies to improve quality of life. Related career development objectives include: 1) Develop a research agenda that targets key factors for nurse-based interventions namely, appraisal (meaning), coping, resources, and personal and situational factors; 2) Develop a strong theoretical knowledge base in cancer prevention and control and related sciences including biostatistics and epidemiology, psychosocial sciences, and health intervention; 3) Explore ethical issues related to providing care, treatments, and support to women with breast cancer; 4) Explore the use of computers and nursing informatics in conducting future breast cancer research. This proposal is consistent with the candidates' immediate and long-term career goals. We will validate a model derived from Lazarus and Folkman's stress-appraisal-coping theoretical framework which identifies factors which place women at risk for poor quality of life after breast cancer, and evaluate two interventions, a specialized breast cancer educational counseling program with a support companion (SBCEP) and a traditional breast cancer educational counseling program (TBCEP) on improving the quality of life of 200 African-American and Caucasian women, ages 30 to 80, with stages I or II breast cancer. Women will be recruited from a local hospital. The impact of age and treatment with and without chemotherapy will be studied. The specific aims are to: 1) Describe the appraisals (meanings), coping, resources, situational and personal factors, and quality of life of women with Stages I or II breast cancer; 2) Validate a model derived from Lazarus and Folkman's stress-appraisal-coping framework which identifies factors which place women at risk for poor quality of life after breast cancer; and 3) Evaluate and compare two interventions, the SBCEP which includes a supportive companion and traditional care (TBCEP) on improving the quality of life among women with breast cancer. The hypothesis predicts that there will be no significant differences between the SBCEP and TBCEP randomized groups in pre-test measures of appraisal, coping, resources including social support, and quality of life, but there will be significant differences between the SBCEP and TBCEP in post test measures of these variables. It is predicted that the experimental intervention (SBCEP) will have more positive effects on quality of life than the control intervention of traditional care (TBCEP).

PERFORMANCE SITE(S) (organization, city, state)

School of Nursing
Lombardi Cancer Center
Georgetown University
3700 Reservoir Road NW
Washington, DC 20007

Holy Cross Hospital
1500 Forest Glen Road
Silver Spring, MD 20910

KEY PERSONNEL. See instructions on Page 11. Use continuation pages as needed to provide the required information in the format shown below.

Name	Organization	Role on Project
Kathleen A. Sternas	Georgetown Univ. School of Nursing	Candidate
Caroline Burnett	Lombardi Cancer Center	Sponsor (mentor)
Jeanne Mandelblatt	Georgetown Univ. School of Nursing	Advisor
Karen Gold	Lombardi Cancer Center	Biostatistician (consultant)
Kate Taylor	Department of Biostatistics	Advisor
Virginia Saba	Lombardi Cancer Center	Advisor
Carol Taylor	Georgetown Univ. School of Nursing	Advisor
	Georgetown Univ. School of Nursing	Advisor
	Center for Clinical Bioethics	

APPENDIX 5
Core Consultations

**CANCER CLINICAL AND ECONOMIC OUTCOMES CORE CONSULTATION
REPORT**

Core Personnel: Burnett

Person Consulting: Sternas

Date of Consult:

Reason for Consultation: Assistance with development of K-01 proposal "Breast Cancer: Counseling, Companions, and Quality of Life" for NINR submission

Time Spent: Approx 6 days

Potential for funding: K-01 award submitted

CANCER CLINICAL AND ECONOMIC OUTCOMES CORE CONSULTATION REPORT

Core Personnel: Lawrence, Mandelblatt, Liang, Yi, Gold

Person Consulting: John Marshall, MD

Date of Consult: 6/99

Reason for Consultation: Assistance with development of "Burden of Colon Cancer in a Managed Care Population". The Core will act as a consulting shared resource in the grant, and be responsible for quality of life survey development and administration to colon cancer patients and controls. The Core would also be responsible for conducting a preliminary cost-effectiveness analysis using QOL data obtained in the survey to determine cost-effectiveness of using COX-2 inhibitors for colon cancer chemoprevention

Time Spent: Approx 14 person-days in proposal preparation

Potential for funding: Submitted to Merck and Co., total grant direct costs approx. \$400,000

**CANCER CLINICAL AND ECONOMIC OUTCOMES CORE CONSULTATION
REPORT**

Core Personnel: Lawrence

Person Consulting: M. Cairo, Bone Marrow Transplant Program

Date of Consult: 7/99

Reason for Consultation: Assistance with cost of running a pilot cord-blood storage unit for potential cord-blood stem cell transplants.

Time Spent: Approx 1 hour

Potential for funding: Currently under discussion, may have future proposal to DOD

CANCER CLINICAL AND ECONOMIC OUTCOMES CORE CONSULTATION REPORT

Core Personnel: Mandelblatt, Gold

Person Consulting: A. Bierman, AHCPR

Date of Consult: 8/99

Reason for Consultation: Consult to Dr. Bierman, Agency for Health Care Policy and Research (AHCPR), for statistical and outcomes consultation for guidance with an AHCPR analysis of the Medicare Health of Seniors (HOS) Study. The Core will be assisting with the analytic design to help determine the impact of race, gender, and socioeconomic status on health status in elderly people in managed care organizations.

Time Spent: Approx 10 personnel days

Potential for funding: Direct contract with AHCPR, \$3000

CANCER CLINICAL AND ECONOMIC OUTCOMES CORE CONSULTATION REPORT

Core Personnel: Lawrence, Liang, Burnett, Yi

Person Consulting: J. Silsby, CRFA

Date of Consult: 7/99

Reason for Consultation: Conduct a feasibility study of a multiphasic cancer screening van in the Metropolitan D.C. area, to potentially include breast, cervical, prostate, colon, and skin cancer screening. Feasibility study is to include logistics of screening in a mobile unit, effectiveness of screening, estimated costs of screening, and distribution of costs by payor.

Time Spent: Approx 10 person-days as of 9/1/99

Potential for funding: Contract in development for \$9800 from Cancer Research Foundation of America

APPENDIX 6
Core Meeting Minutes and Core Seminar Schedule

Cancer Clinical and Economic Outcomes Core
Bimonthly Meeting
2:30 p.m. ~ 3:30 p.m. 9/15/98
CPC 4th floor Conference Room

Members

Jeanne Mandelblatt, MD, MPH;* William Lawrence, MD, MSIE;* Caroline Burnett, RN, ScD;* Karen Gold, PhD;* Jack Hadley, PhD; Claudine Isaacs, MD; Lenora Johnson, MPH, CHES; Wenchi Liang, DDS, PhD;* Julia Rowland, PhD; Kate Taylor, PhD

** Attendees*

Next Meeting: November 17, 1998 (Tuesday), 2:30 ~ 3:30 pm	
Person	Assignments/Tasks
Bill	Circulate the schedule for the Core Lecture Series
Bill	Circulate the Shared Resources booklet

DoD Breast Cancer Studies

a. BRCA1/2 (CARE)

As of August 31, 1998, 75, 109, and 139 patients have completed the utility interviews (Time Trade-Off and HUI) at baseline, 6-month followup, and 12-month followup, respectively. Preliminary analysis found little variation in utility scores, and the correlations between TTO and HUI to be insignificant. We expect to see differences in utilities between baseline and 6-month followup as a result of intervention (genetic counseling).

Reliability and validity of the survey instruments are tested through a second face-to-face interview conducted by Audra Doss during the visit for genetic counseling. Our goal is to complete 20 interviews and analyze the correlation between telephone and face-to-face interviews. Based on the current data, the correlations are 0.4 for TTO and 0.9 for LRS. The low correlation of 0.4 may result from different modes of survey administration, real changes in the short period of time, or low reliability of the instrument.

b. CAB/CAD

Sixty-six completed surveys have been entered and analyzed.

The manuscript "Serendipity in diagnostic imaging: Magnetic Resonance Imaging of the breast" has been accepted by Journal of the National Cancer Institute, and will be published on December 2, 1998.

c. Palliative Treatments (Thalidomide / TNP-470 with Taxol)

The Thalidomide study was closed early because no patients responded to the medication after 8 weeks of followups. Cost and satisfaction surveys were collected from 5 patients at baseline and/or various points of followups.

The TNP-470 and Taxol study began to recruit patients in July. Six patients have received the treatment. Wenchi and Jenny Crawford (the research nurse) will check and make sure every patient receives baseline and followup surveys at every visit.

DoD Annual Renewal Report (End of September, 1998)

The annual renewal report has been sent to Joy Beveridge on September 14, and will be distributed at the next meeting on November 17.

Core Lecture Series

The Core lecture series will focus on methodological issues for cost-effectiveness, medical decision-making, utilities, etc., and how they can be applied to other areas of studies. It will be a bimonthly lecture, conducted by one of the Core members each time. Tentatively the lecture will run 45 minutes, right after our Core meeting. Another option is to combine this series with Wednesday Lecture Series.

Members have signed up for the lecture topics. Please refer to the attached file for the list. Anyone who is interested to present other topics should contact Bill for details. The schedule for the lecture series will be distributed as soon as the time, place, and format are finalized.

Marc Lippman suggested this series to be incorporated with oncology fellowship program, or put to marketing. It may also grow into a independent fellowship in the future.

Revenue Generation: Shared resource issues -- Core funding

Bill distributed the draft introduction of our Core that will be put in the Shared Resources book (see attached file). Bill will attend the next meeting about shared resources on September 30, and distribute the book to everyone.

Cancer Clinical and Economic Outcomes Core
Bimonthly Meeting
2:30 p.m. ~ 3:30 p.m. 11/17/98
CPC 4th floor Conference Room

Members

Jeanne Mandelblatt, MD, MPH;* William Lawrence, MD, MSIE;* Caroline Burnett, RN, ScD;* Karen Gold, PhD;* Jack Hadley, PhD; Claudine Isaacs, MD; Lenora Johnson, MPH, CHES; Wenchi Liang, DDS, PhD;* Julia Rowland, PhD;* Kate Taylor, PhD*

** Attendees*

Next Meeting: January 21, 1999 (Thursday), 2:00 ~ 3:30 pm	
Person	Assignments/Tasks
-----	-----
Bill	Core lecture: Cost effectiveness analysis in cancer prevention

DoD Breast Cancer Studies

a. BRCA1/2 (CARE)

From 9/1/98 to 11/15/98, 44, 20, 30 patients have completed the utility interviews (Time Trade-Off and HUI) at baseline, 6-month followup, and 12-month followup, respectively. The total number of completed surveys increase to 119, 129, and 169.

Wenchi is drafting a proposal for requesting the use of SEER-Medicare linked database to the NCI. We will use these data to estimate the life-time cost of breast cancer care for women with primary breast cancer according to the age and cancer stage at diagnosis. The estimated costs will be used in the BRCA cost-effectiveness analysis model.

b. CAB/CAD

Additional 12 patients completed the Satisfaction surveys.

The training manual of survey administration is under review. Bill and Wenchi will discuss this manual with Bruce and Miriam Mullins once it is finalized. It is suggested that if patients do not have time to fill out the survey at the end of the visit, the study coordinator can ask them to complete the survey later and mail them back to Georgetown.

c. Palliative Treatments: TNP-470 with Taxol

Nine patients have been scheduled to receive the treatment since the study began in July, 1998. This study will steadily recruit 3 cancer patients for treatment each month.

Core Lecture Series

The Core lecture series will start in January, 1999. It will be a bimonthly lecture, conducted by one of the Core members each time. Ultimately, we plan to make this lecture available to the public such as physicians and clinical researchers. We decided to extend the Core meeting to one and half hours, and use the last 45 minutes for the lecture. Kathy will distribute the 1999 schedule to everyone.

Revenue Generation: Shared resource issues -- Core funding

We do not have any new consults. We still need to figure out the optimal way to calculate the costs of consultation for each project--either by support to the Core or by support to be added in the grant.

Cancer Clinical and Economic Outcomes Core

Bimonthly Meeting

2:00 p.m. ~ 3:30 p.m. 1/21/99

CPC 4th floor Conference Room

Members

Jeanne Mandelblatt, MD, MPH; William Lawrence, MD, MSIE; Caroline Burnett, RN, ScD; Karen Gold, PhD; Jack Hadley, PhD; Claudine Isaacs, MD; Lenora Johnson, MPH, CHES; Wenchi Liang, DDS, PhD; Julia Rowland, PhD; Kate Taylor, PhD; Bin Yi, MS

Lecture: Topic: Cost-effectiveness in cancer prevention
Speaker: William Lawrence, MD, MSIE

DoD Breast Cancer Studies

- a. BRCA1/2 (CARE)
 - 38 baselines, 13 6-month f/u, 14 12-month f/u (11/16/98 ~ 1/15/99)
 - Time Trade-Off questions dropped from CARE surveys (1/4/99)
 - BRCA model
 - Cost of breast cancer care from SEER-Medicare linked data
- b. CAB/CAD
 - 18 additional completed surveys
 - Survey data entered into the computer database
 - Revised survey forms: Removed digital mammography & Sonography tests
- c. Palliative Treatments (TNP-470 with Taxol/Thalidomide)
 - 14 recruited in the TNP study; 7 remained on study as of 1/20/99
 - No specific projected accrual, possibly 30 patients at the rate of 3 per month
 - Thalidomide data mostly entered to the database (near completion)

Schedule for 1999 Core Lecture Series

William Lawrence	January 21
Julia Rowland	March 25
Kathryn Taylor	May 27
Caroline Burnett	July 22
Karen Gold	September 23
Wenchi Liang	November 18

New grants

CALGB grant

Agenda for next meeting (March 25)

**Cancer Clinical and Economic Outcomes Core
Bimonthly Meeting**

2:00 p.m. ~ 3:30 p.m. 3/25/99

CPC 4th floor Conference Room

Members

Jeanne Mandelblatt, MD, MPH; William Lawrence, MD, MSIE; Caroline Burnett, RN, ScD; Karen Gold, PhD; Jack Hadley, PhD; Claudine Isaacs, MD; Lenora Johnson, MPH, CHES; Wenchi Liang, DDS, PhD; Julia Rowland, PhD; Kate Taylor, PhD; Bin Yi, MS

DoD Breast Cancer Studies

- a. BRCA1/2 (CARE)
 - 38 baselines, 13 6-month f/u, 14 12-month f/u (11/16/98 ~ 1/15/99)
 - Time Trade-Off questions dropped from CARE surveys (1/4/99)
 - BRCA model
 - Cost of breast cancer care from SEER-Medicare linked data
- b. CAB/CAD
 - 18 additional completed surveys
 - Survey data entered into the computer database
 - Revised survey forms: Removed digital mammography & Sonography tests
- c. Palliative Treatments (TNP-470 with Taxol/Thalidomide)
 - 14 recruited in the TNP study; 7 remained on study as of 1/20/99
 - No specific projected accrual, possibly 30 patients at the rate of 3 per month
 - Thalidomide data mostly entered to the database (near completion)

Schedule for 1999 Core Lecture Series

William Lawrence	January 21
Julia Rowland	March 25
Kathryn Taylor	May 27
Caroline Burnett	July 2
Karen Gold	September 23
Wenchi Liang	November 18

New grants

CALGB grant

Agenda for next meeting (May 27)

Cancer Clinical and Economic Outcomes Core
Bimonthly Meeting

2:00 p.m. ~ 3:30 p.m. 5/27/99

Suite 400 Conference Room

Members

Jeanne Mandelblatt, MD, MPH; William Lawrence, MD, MSIE; Caroline Burnett, RN, ScD; Karen Gold, PhD; Jack Hadley, PhD; Claudine Isaacs, MD; Wenchi Liang, PhD; Julia Rowland, PhD; Kate Taylor, PhD; Bin Yi, MS

Lecture: Topic: Health-Related Quality of Life in the PLCO Screening Trial:
The Impact of Baseline Screening Results.
Speaker: Kate Taylor, Ph.D.

DoD Breast Cancer Studies (Update: 1/16/99 ~ 5/21/99)

- a. BRCA1/2 (CARE)
 - 113 baselines, 64 6-month f/u, 34 12-month f/u
 - BRCA model

- b. CAB/CAD
 - 21 more patients participated.
 - Miriam Mullins (the Coordinator) will leave her job on 5/28; no replacement is finalized yet.

- c. Palliative Treatments (TNP-470 with Taxol)
 - A total of 19 patients have received the treatment
 - Survey data will be entered as soon as the LCC finds a new data entry person to resume Galina's job (She is leaving in two weeks).

New Consults

1. Care-Giver Burden of Terminal Ill Patients (Jane Ingham)

2. Burden of Colorectal Cancer in a Managed Care Population (John Marshall)

This study is sponsored by Merck Pharmaceutical Co. who is interested in burden of colorectal cancer care in the Managed Care population. Jeanne, Bill, and Karen will be responsible for cost analysis, quality of life, and satisfaction with care. Patients will be contacted for a telephone survey; medical records will be reviewed for their background information. This consult will also include a cost-effectiveness modeling that assesses the impact of chemoprophylaxis with cyclo-oxygenase 2 (COX-2) inhibitor on costs and outcomes of colorectal cancer.

3. Intervention to Improve Mammography Adherence (Caroline Burnett)

This NIH-funded study is aimed to use a community-based intervention to increase the use of regular mammography in African American women. Howard University leads this project. GUMC is under the contract to evaluate the adherence of mammography at year 1 and 2 follow-ups (Caroline) and cost-effectiveness of the program (Bill).

4. Cost Analysis of Cord Blood Banking (Mitchell Cairo)

It's a \$500,000 pilot grant from the U.S. Department of Navy to look at the cost-effectiveness of Cord Blood Banking by different methods.

Schedule for 1999 Core Lecture Series

Caroline Burnett	July 22
Karen Gold	September 23
Wenchi Liang	November 18