

**GROUND MOTION EFFECTS FROM NUCLEAR EXPLOSIONS:  
A REVIEW OF DAMAGE EXPERIENCE  
AND PREDICTION METHODS**

Fred Holzer

June 2, 1971

Prepared for U.S. Atomic Energy Commission under contract No. W-7405-Eng-48



**LAWRENCE  
RADIATION  
LABORATORY**  
University of California  
**LIVERMORE**

**Reproduced From  
Best Available Copy**

**DISTRIBUTION STATEMENT A**  
Approved for Public Release  
Distribution Unlimited

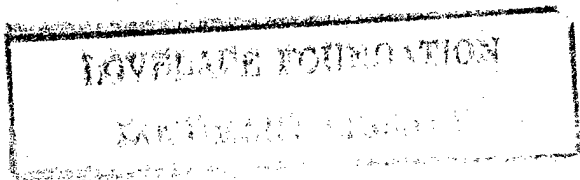

TID-4500, UC-35  
Nuclear Explosions—  
Peaceful Applications

**Lawrence Radiation Laboratory**

UNIVERSITY OF CALIFORNIA

LIVERMORE

94550

UCRL-51062

**GROUND MOTION EFFECTS FROM NUCLEAR EXPLOSIONS:  
A REVIEW OF DAMAGE EXPERIENCE  
AND PREDICTION METHODS**

Fred Holzer

MS. date: June 2, 1971

## Contents

Abstract . . . . .	1
Introduction . . . . .	1
Correlation of Damage with Peak Surface Velocities . . . . .	2
Damage Correlation with Response Spectrum Amplitude . . . . .	7
Ground Motion and Spectrum Prediction . . . . .	13
Acknowledgments . . . . .	22
References . . . . .	23
Distribution . . . . .	24

# GROUND MOTION EFFECTS FROM NUCLEAR EXPLOSIONS: A REVIEW OF DAMAGE EXPERIENCE AND PREDICTION METHODS

## Abstract

Ground motion from nuclear explosions can damage one- and two-story buildings when surface velocities are as low as 0.1 to 0.2 cm/sec, while high explosive blasting experience had previously suggested a threshold of between 5 and 10 cm/sec. Subsequent studies indicate that this damage correlates best with the average amplitude of the pseudo absolute acceleration (PSAA) in the 0.05 to 0.2 sec period range. Present data indicate a damage threshold of about 10 cm/sec<sup>2</sup>, while at PSAA's of about 1000 cm/sec<sup>2</sup>,

damage to over half of the buildings can be expected. This damage is architectural in nature, consisting predominantly of cracked interior plaster, cracked brittle masonry walls, and damaged chimneys; about two-thirds of the Rulison damage was of this nature. The use of this damage prediction method requires the correct prediction of response spectra. The accuracy of such predictions has been greatly improved by employing frequency dependent yield and depth scaling.

## Introduction

From the inception of the Plowshare Program it has been recognized that understanding and predicting the ground motion generated by the explosion and any associated building or structural damage was necessary if nuclear explosions for peaceful purposes were to achieve their maximum usefulness and employment.<sup>1</sup> For the past decade, the U. S. Atomic Energy Commission has sponsored a continuing research program aimed at predicting amounts and extent of so-called "seismic damage" from underground nuclear detonations. As a result, theories

and methods have been developed that enable us to estimate, with reasonable accuracies, the ground motion from single detonations in the sandstone-shale medium most often encountered in deep nuclear explosions for gas stimulation. Ground motion parameters which appear to best correlate with damage have been identified, and permit the amount of damage to be estimated. Clearly, a number of improvements in both motion and damage predictions need to be made. In addition, more sophisticated approaches have been made which approach damage

predictions from a probabilistic standpoint.<sup>2</sup> In this paper I attempt to review the steps by which some of the methods now in use have been developed, and

present the status of these methods. No claim to an exhaustive treatment is made, and it should be kept in mind that not all answers are presently in hand.

## Correlation of Damage with Peak Surface Velocities

As an initial approach to studying predictive methods of ground motion, we investigated the experience of industry with high explosives used in quarry and mine blasting.<sup>3</sup> We recognized from the beginning that the time-history of the ground motion produced by a nuclear explosion would not be the same as that produced from high explosives and that, in particular, more low-frequency amplitudes might be expected from the

nuclear explosion. However, the existing blasting data seem to indicate that the threshold for damage to residential buildings (manifesting itself primarily in the cracking of plaster) might be independent of frequency of ground motion.<sup>4</sup> The data leading to this conclusion are shown in Fig. 1, which suggests that below an amplitude of about 10 cm/sec, no (or very little) damage might be expected. Such a frequency-independent

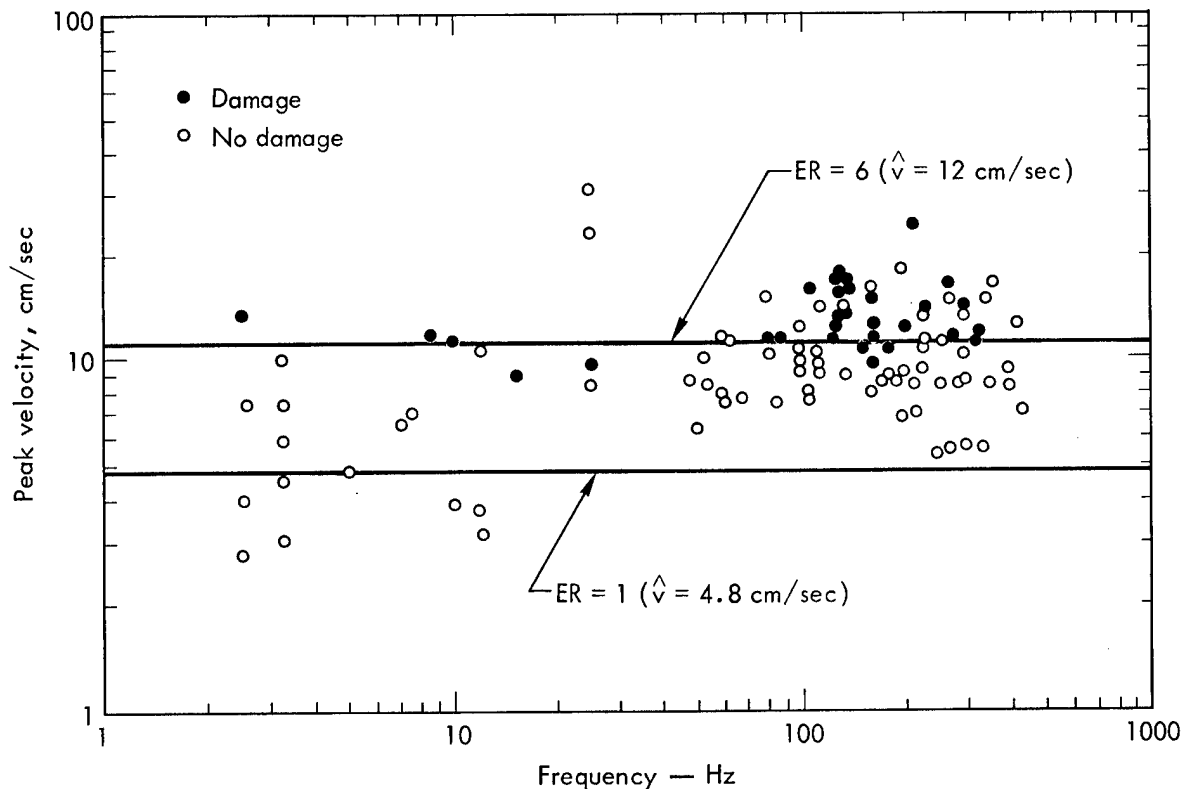

Fig. 1. First estimates of damage threshold, based on peak surface velocity. ER (energy ratio) defined as  $A^2/F^2$ , where  $A$  = acceleration in  $\text{ft}/\text{sec}^2$  and  $F$  = frequency in Hz.

$$\begin{array}{l}
 D \equiv \text{MAX Displ} \\
 V \equiv \text{MAX Vel of DF} \\
 A \equiv \text{MAX Accel of DF}
 \end{array}
 \left. \vphantom{\begin{array}{l} D \\ V \\ A \end{array}} \right\} \text{where } F \equiv \text{Frequency of sinusoidal wave} \Rightarrow \frac{A}{F} \propto DF \propto V \text{ OR } A^2/F^2 \propto V^2$$

damage behavior can also be expressed in terms of an energy ratio defined as  $A^2/F^2$ , where A is the acceleration in ft/sec<sup>2</sup> and F is the frequency in Hz.

Regulations adopted by several states of the USA as well as by the U.S. Corps of Engineers set an energy ratio of 1 as the criterion for motion below which damage would not be expected. Such an energy ratio of 1 corresponds to a peak surface velocity of about 4.8 cm/sec, assuming simple harmonic motion.

This concept of a damage threshold of between 5 and 10 cm/sec was rudely shattered as a result of the Salmon explosion, a 5-kt detonation at a depth of 825 meters in a salt dome near Hattiesburg, Mississippi. Approximately 1000 claims for damage to buildings were filed from the surrounding communities.<sup>5</sup> Although the few ground motion measurements made were ambiguous, it was certain that surface velocities were very much lower than any damage threshold previously proposed. Table 1 lists surface velocities and the percentage of damage claims from three of the communities in the vicinity of the Salmon experiment. Figure 2 shows an example of the type of damage to buildings caused from the ground motion. The type of damage was totally confined to what has been termed "architectural" in nature,

Table 1. Claims for building damage from the Salmon experiment.

Location	Peak surface velocity (cm/sec)	Claims/structure (%)
Lumberton	~1.3	25
Purvis	~0.8	40
Hattiesburg	~0.4	3

as contrasted with "structural"; that is, the damage involved cracking of interior plaster or brittle stucco or masonry walls, but not structural elements. Many of the cracks similar to the one shown in the figure closed with the passage of time, making a valid determination of actual damage very difficult.

The Salmon experience gave renewed impetus to understand the mechanism of building damage and to find ground motion parameters which could be correlated with building damage. In particular, the apparent violation of the previously accepted surface velocity criteria demanded further study. This was carried out at the AEC's Nevada Test Site in 1965, in conjunction with the then on-going series of underground nuclear explosions. At the Base Support Camp for these detonations, a series of new buildings had been erected during 1964. These buildings were primarily one-story structures constructed of concrete block and used for housing, maintenance facilities, and office space. Figure 3 shows a typical building of this type. Forty-three of these buildings were selected for detailed study and were carefully examined inside and out before and after each nuclear explosion, as well as at intervals between explosions. Exterior and interior cracks and fractures were marked, identified, and measured, and ground motion measurements were made in the area covered by these buildings. The results of this study<sup>6</sup> are shown in Fig. 4, in which the total cumulative number of cracks for all 43 buildings is shown as a function of time in the study. It was found that, on the average, 2-1/2 new cracks appeared every day, constituting

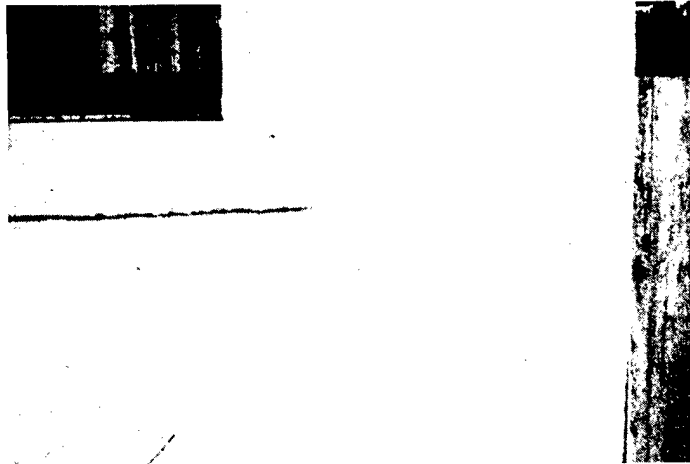

Fig. 2. Example of damage in Hattiesburg, Miss. from Salmon event.



Fig. 3. Type of concrete block building used in Nevada Test Site damage study.

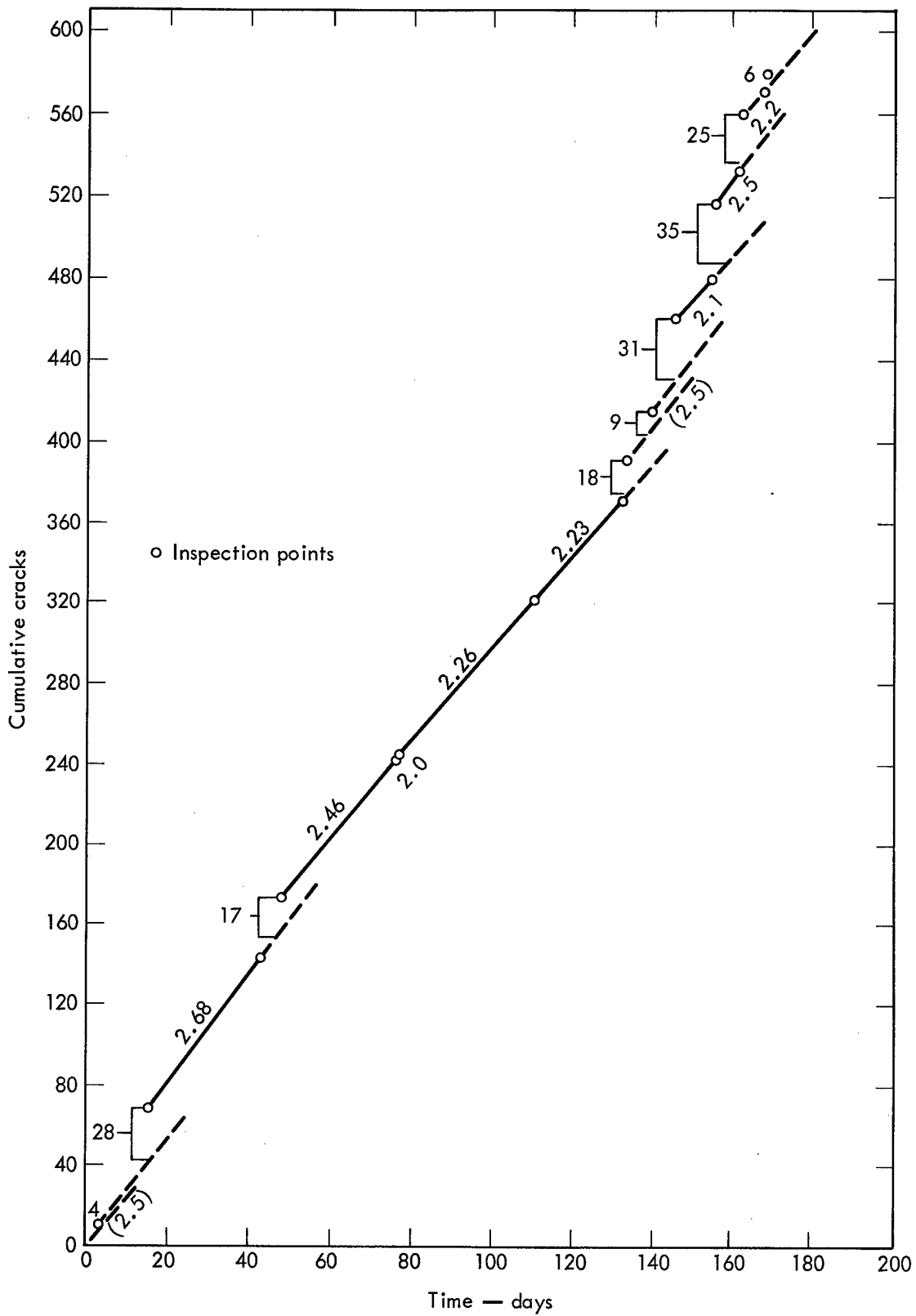

Fig. 4. Cumulative cracks and cracking rates—NTS study.



a natural cracking rate for these particular buildings. The steps shown in Fig. 4 represent additional fractures caused by nuclear explosions taking place that day. These latter fractures were physically indistinguishable from those which occurred normally. All of them were architectural

in nature, and most of them of the type easily overlooked in a casual inspection. An example is shown in Fig. 5. Maximum surface velocity in all cases was less than about 0.3 cm/sec, confirming that some type of minimal damage can be caused by motions of very low amplitude.

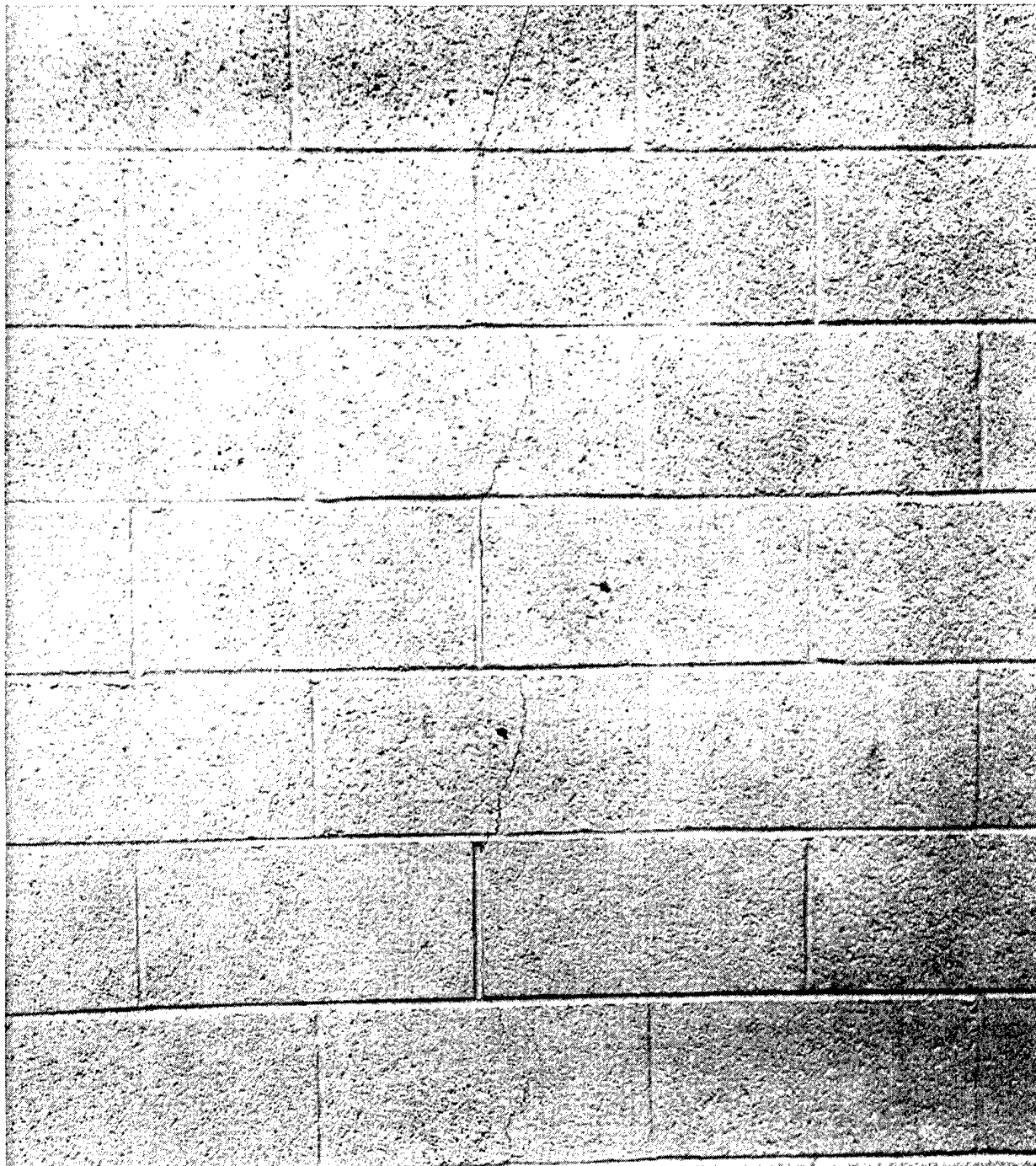

Fig. 5. Example of damage—NTS study.

## Damage Correlation with Response Spectrum Amplitudes

It became obvious that in order to make further progress, the amplification of the ground motion by the structures must be considered. A natural avenue of attack in this direction is through the concept of the response spectrum.<sup>7</sup> This method has been used to study natural vibrations of buildings and is based on the simplifying assumption that the re-

sponse of a structure can be approximated by the envelope formed by the maximum response of a series of simple harmonic oscillators which are tuned to different frequencies and damped to a fixed percentage of the critical value.<sup>8</sup>

The generation of the spectrum is depicted schematically in Fig. 6, where the maximum relative displacement of

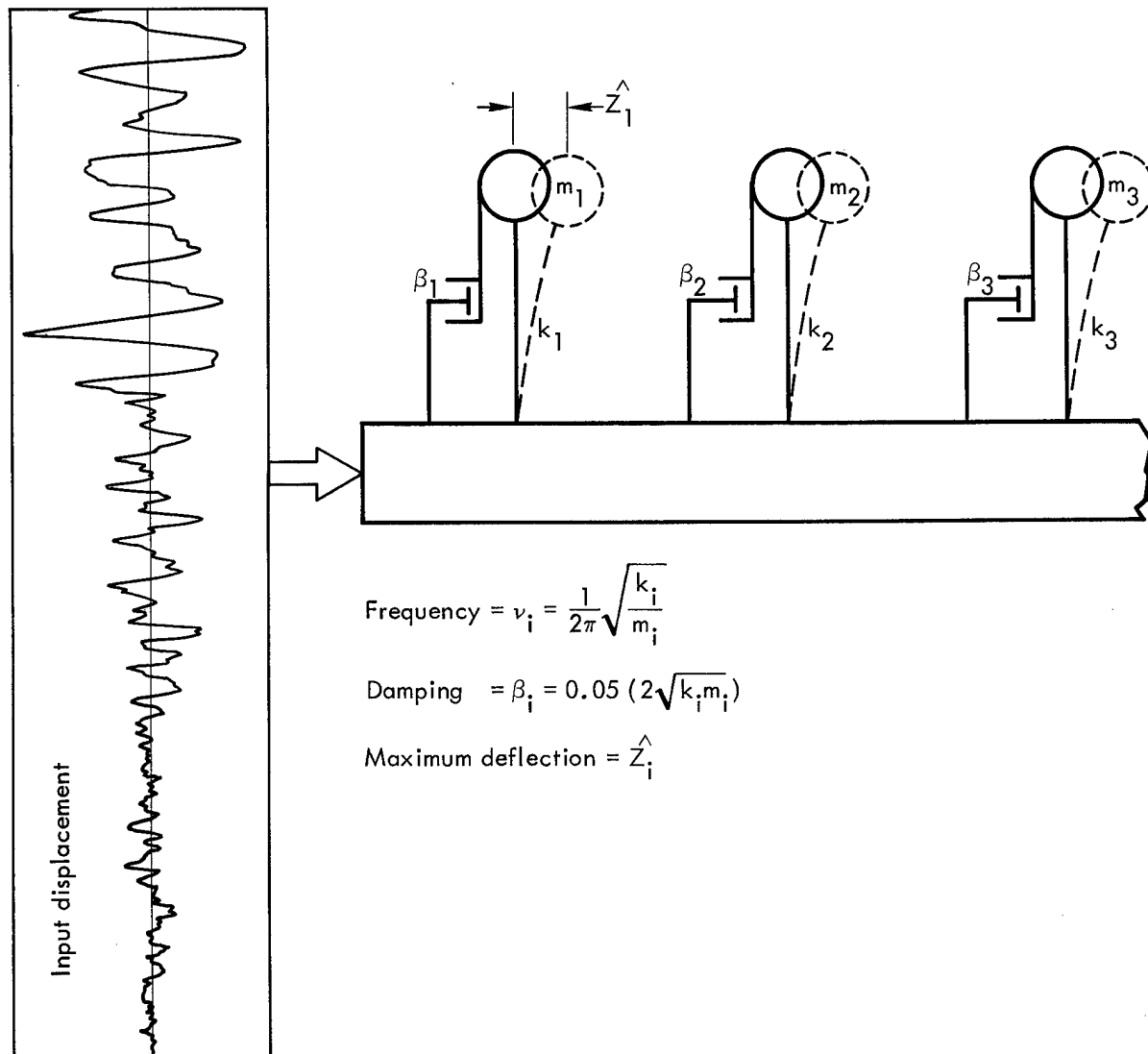

Fig. 6. Definition and calculation of response spectrum.

each vibrating mass with respect to its rest position on the base is determined when the base is subjected to the measured ground displacement. In practice, this procedure is performed on a high-

speed computer. Once relative displacement is calculated, it is convenient to compute the associated velocities and accelerations on the assumption of simple harmonic motion. This permits all three

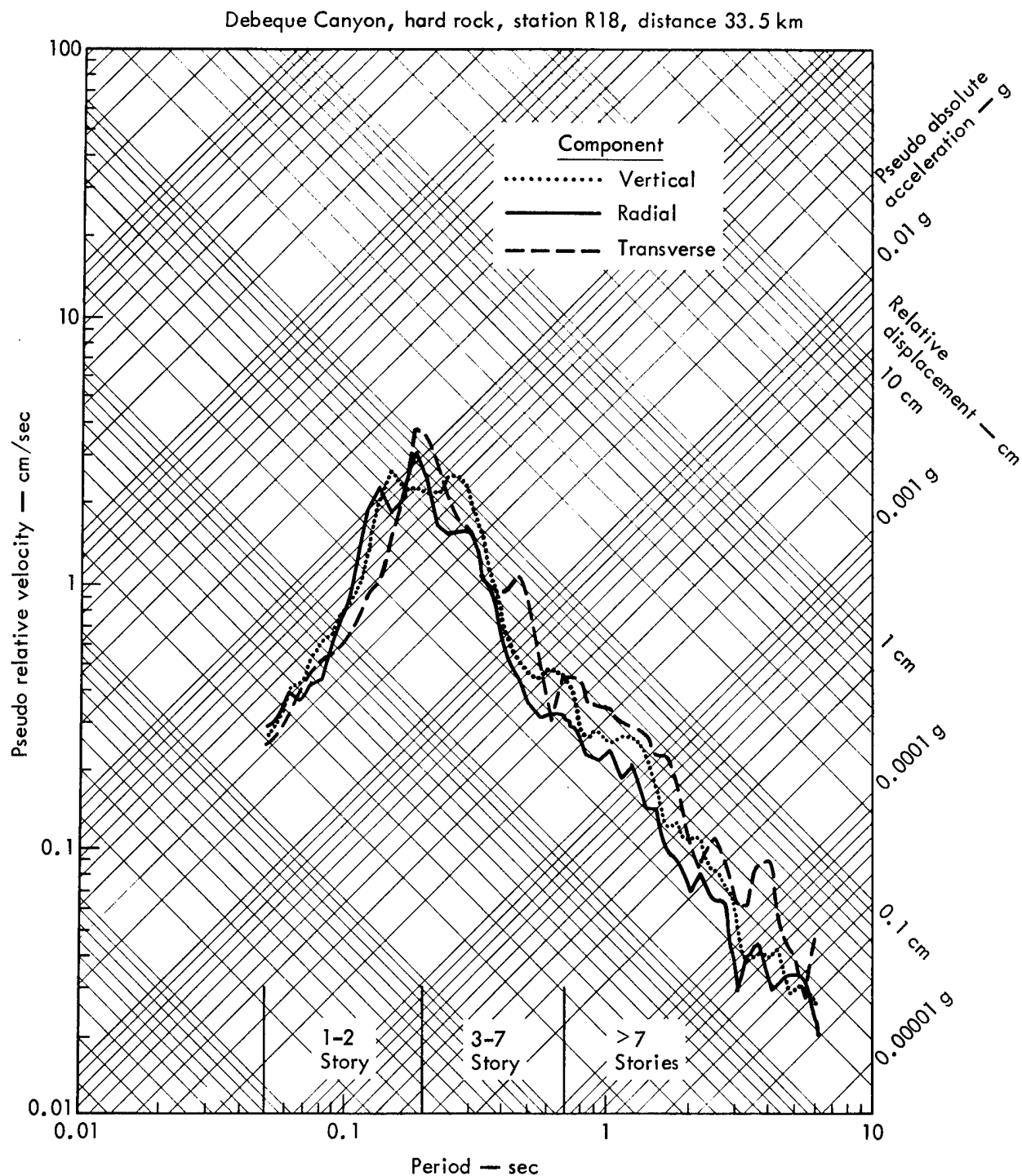

Fig. 7. Sample spectrum, with regions of building response.

quantities to be shown as a function of frequency or period on a four-way graphical plot which is especially convenient for purposes of correlating the various amplitudes with damage. A typical spectrum is shown in Fig. 7, which also shows the approximate period intervals in which buildings of various heights have been found to resonate. The relation between spectral amplitudes and resonant building frequencies is an important one: for example, if there are no buildings above three stories in the area of interest, the spectral amplitudes above a period of about 0.2 sec are unimportant as far as any damage prediction is concerned.

For one- or two-story buildings, where frequencies in the 5 to 20 Hz range (periods of 0.05 to 0.2 sec) are important, Nadolski<sup>7</sup> has shown that the value of the pseudo-absolute acceleration (PSAA) seems to correlate better with observed damage than any other motion parameter. The extensive ground motion measurements made on the Rulison experiment<sup>9</sup> (43 ± 8 kt at a depth of 2570 meters in sandstone/shale) together with thorough damage documentation<sup>10</sup> has permitted this correlation to be made much more definitively. This has been done by

Rizer<sup>11</sup> and, more recently, by Farhoomand and Scholl.<sup>12</sup> Table 2 summarizes ground motions, spectral amplitudes, and damage numbers from the Rulison experiment. These, together with some additional points from the Salmon experiment and experience at Las Vegas, are shown in Fig. 8. This figure shows that at PSAA levels of close to 1 g, in the 0.05 to 0.2 sec period interval, over 50% of one- to two-story structures can be expected to sustain some damage. At about 0.01 g, damage will be sporadic and no (or very little) damage can be expected at lower values. The line shown in Fig. 8 can serve as a quick and convenient method of estimating building damage for one or two story structures in the vicinity of nuclear detonations, if the response spectra at these building locations can be predicted.

The results from Rulison show that even at spectral accelerations approaching the 1 g level, actual damage was again confined to architectural or ornamental features of the buildings involved. Table 3 summarizes the type of damage found in the communities surrounding the Rulison experiment. Over half of the total damage involved cracking of interior plaster partitions or damage to brick chimneys.

Table 2. Rulison damage correlation.

Location	Distance (km)	Peak accel. (g)	PSAA		Number of buildings	Number damaged	Percent
			0.05—0.2 sec	(g)			
Grand Valley	10.6	0.55	0.85		164	76	46.5
Collbran	19	—	0.1		139	6	4.3
Rifle	20	0.10	0.2		818	70	8.5
De Beque	23	0.10	0.15		106	6	5.7
Silt	30	0.035	0.08		168	6	3.6
Grand Junction	65	0.017	0.03		~4000	3	0.075

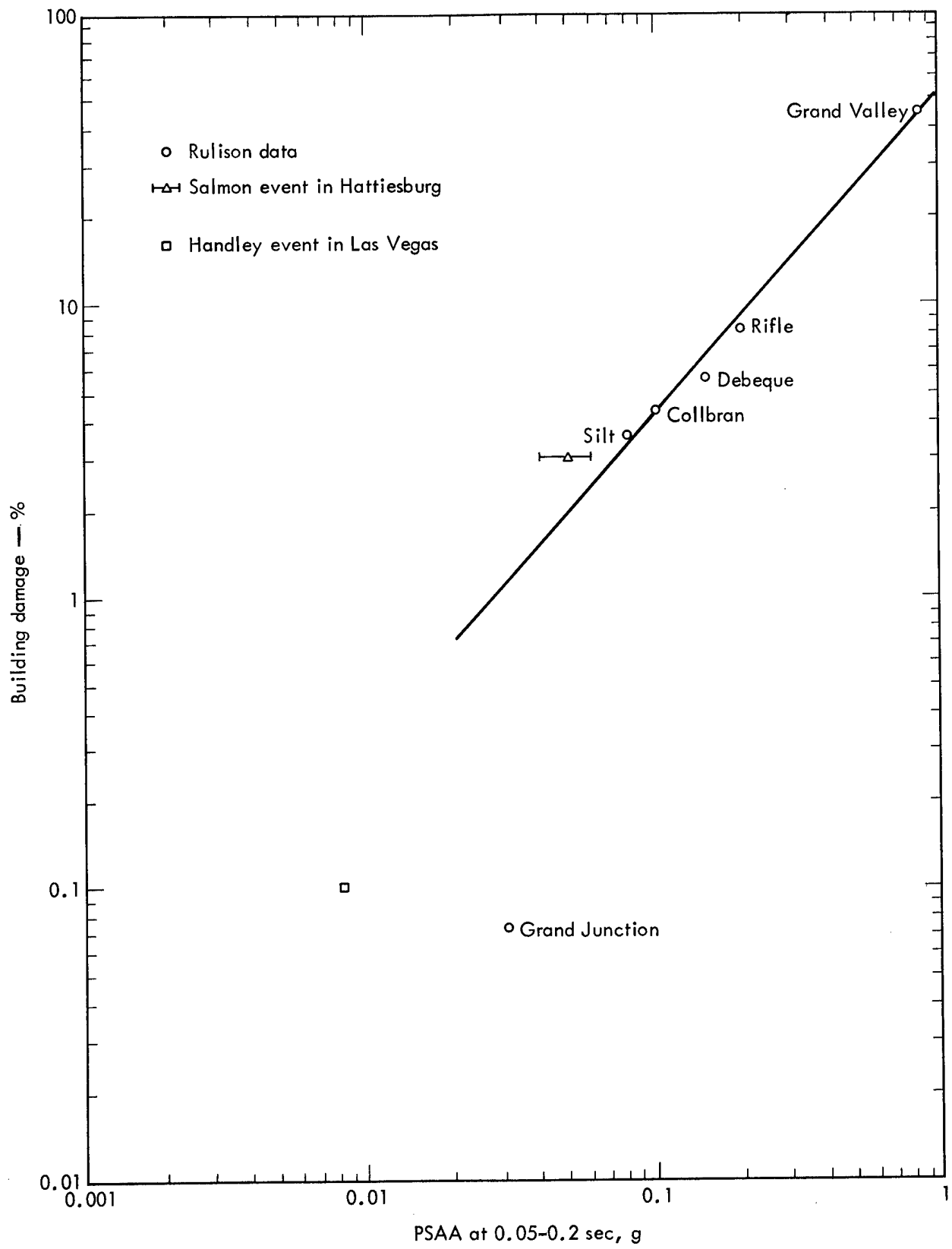

Fig. 8. Correlation between damage and PSAA.

Examples of this damage are shown in Figs. 9-11. In all cases, the damage was easily repaired at an average cost of less than \$300 per claim.

While it might be expected that the average repair costs would be less at lower motion levels, Farhoomand and Scholl were not able to establish such a

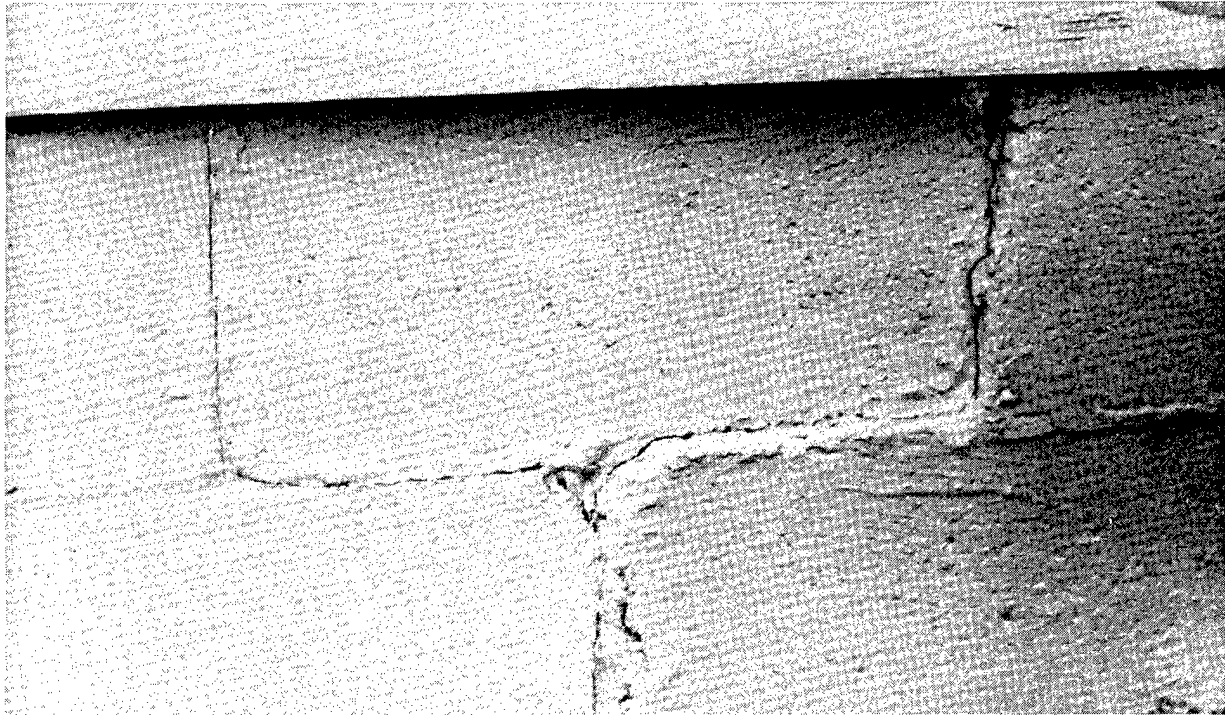

Fig. 9. Example of Rulison damage.



Fig. 10. Example of Rulison damage.

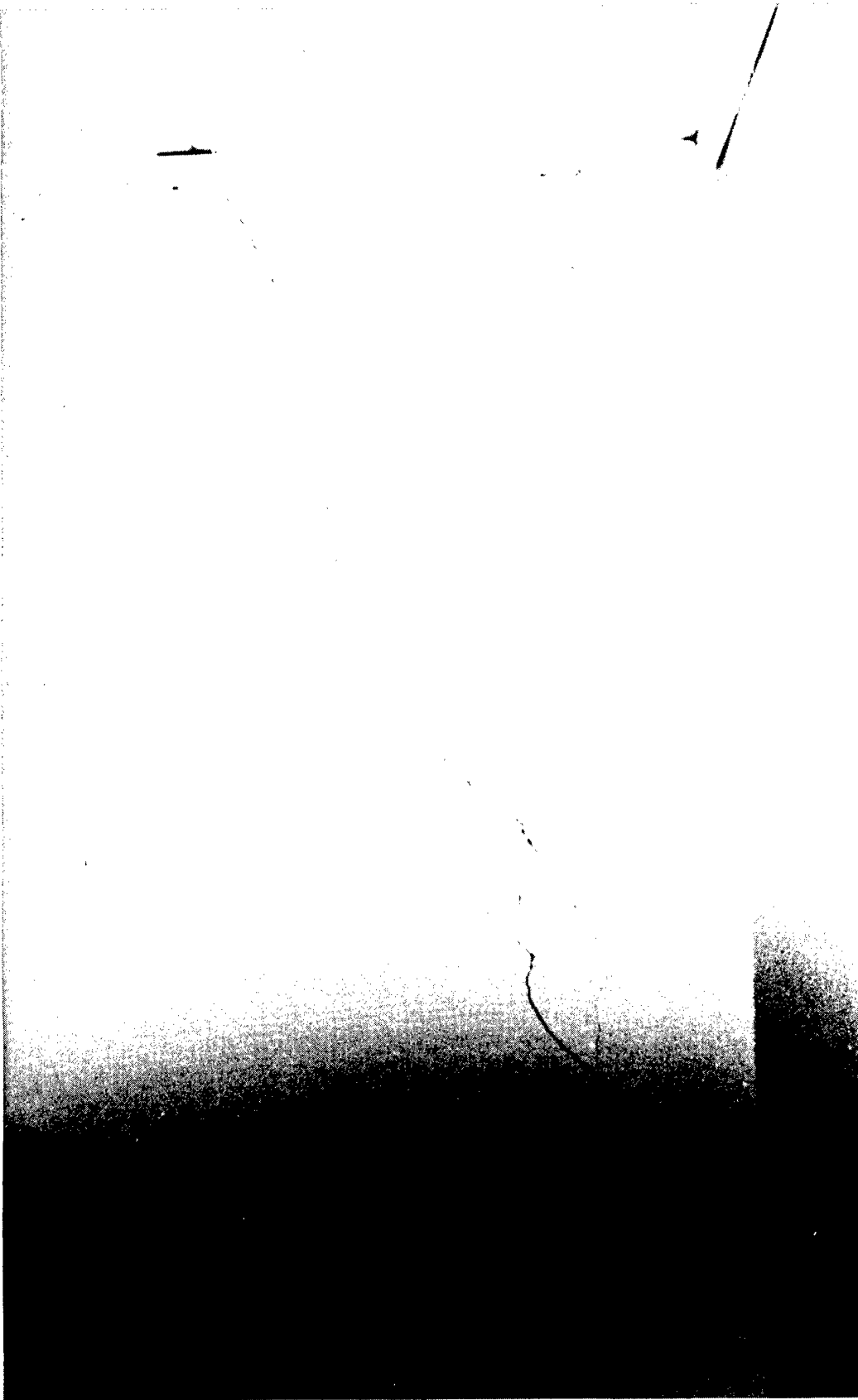

Fig. 11. Example of Rulison damage.

Table 3. Types and numbers of Rulison damage.

Chimneys	143
Interior plaster	148
Exterior walls	69
Foundation walls	66
Windows	24
Fireplaces	15
Furnishings	22
Wells and cisterns	27
Other	43
Total	557

correlation for the Rulison damage experience<sup>12</sup>; however, these authors have shown that a good correlation seems to exist between the maximum PSAA in the relevant frequency interval and the damage repair cost divided by the value of the buildings. Such a procedure, however, may be difficult to apply universally and may also be different for different damage adjustments depending, for example, whether damage is repaired or its cost reimbursed.

## Ground Motion and Spectrum Prediction

Prerequisite to the use of the method presented above is the prediction of the response spectrum at the various population and building centers which might be affected from a proposed nuclear detonation. The prediction of peak values of ground motion as well as those of response spectra has been continuously refined with the aid of an extensive measurements program, both in Nevada and elsewhere.<sup>13,14</sup> However, it was not until measurements from Gasbuggy could be compared with predictions<sup>15</sup> that it became clear that the scaling factors developed on the basis of past experience were not adequate for very deeply buried explosions. Figure 12 compares Gasbuggy observed and predicted peak accelerations; the measured values were clearly higher than predicted. As a result, response spectra were displaced towards higher frequencies, leading to higher PSAA values. These discrepancies, as well as the detailed analysis of data from the Nevada Test Site,<sup>14</sup> have led Mueller and

Murphy to a theoretical approach to scaling<sup>16</sup> which shows that both spectral and ground motion amplitudes depend not only on yield and medium properties, but on the depth of burst as well. The depth-of-burst dependence leads to higher PSAA and higher surface acceleration with increased depth of burial. The development of this theory uses the wave equation and Hooke's law to relate the displacement with the pressure function at the elastic radius. The dependence on frequency enters naturally when Fourier transforms of these functions are considered. For two events detonated in the same material, the two spectra are related by

$$\frac{|Z_1(\omega)|}{|Z_2(\omega)|} = \frac{|P_{1-el}|}{|P_{2-el}|} \frac{r_{1-el}}{r_{2-el}}$$

$$\times \left[ \frac{(\omega_{02}^2 - \beta\omega^2)^2 + \omega_{02}^2 \omega^2}{(\omega_{01}^2 - \beta\omega^2)^2 + \omega_{01}^2 \omega^2} \right]^{1/2}$$



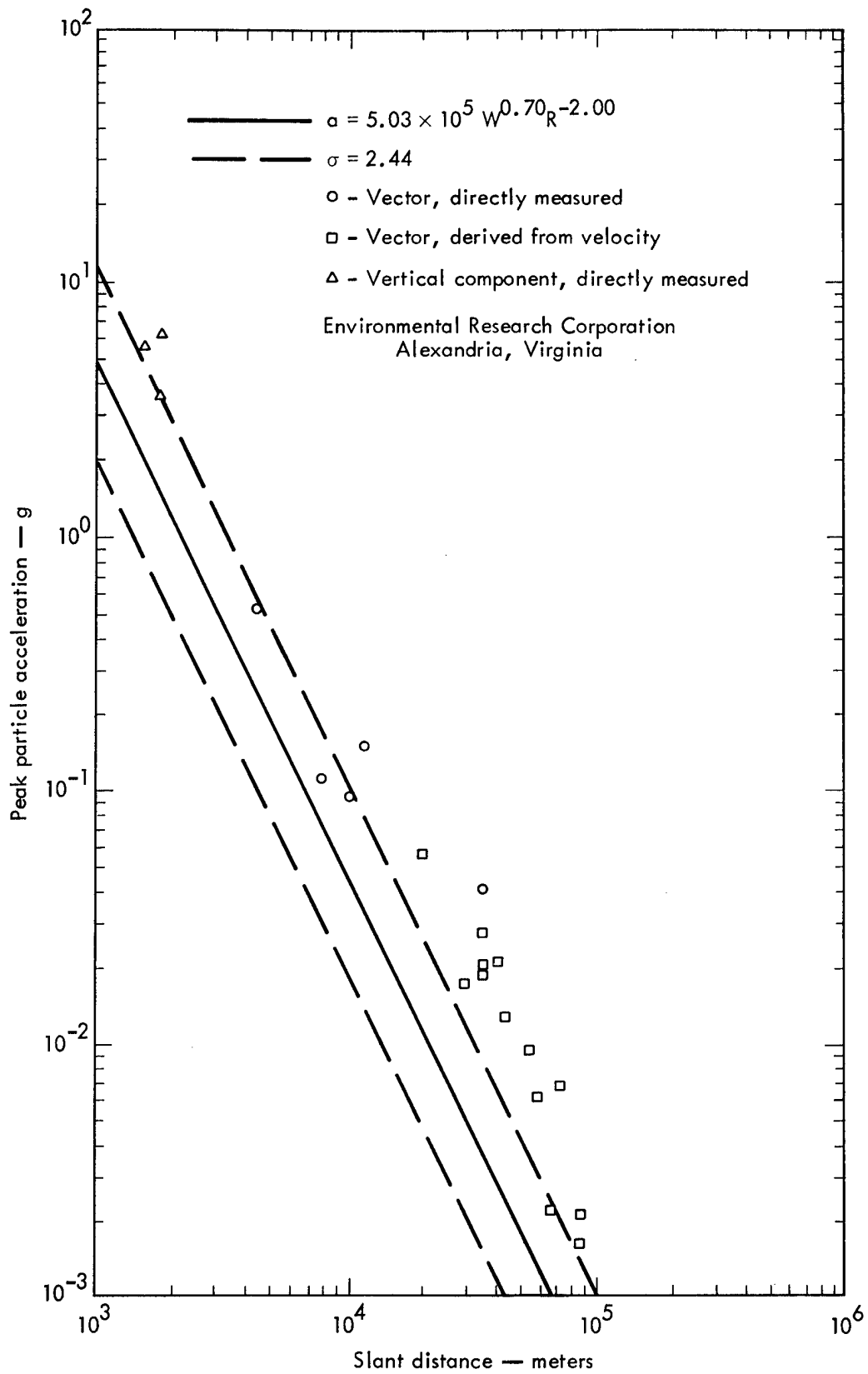

Fig. 12. Comparison of observed and predicted peak surface acceleration—Gasbuggy.

where

$|Z(\omega)|$  = modulus of the Fourier transform of the displacement,

$|P_{el}|$  = modulus of the Fourier transform of the pressure at the elastic radius  $r_{el}$ ,

$\omega_0 = \frac{c}{r_{el}}$ , where  $c$  is the compressional velocity, and

$\beta = \frac{\lambda + 2\mu}{4\mu}$ , where  $\lambda$  and  $\mu$  are the Lamé constants.

Both  $|P_{el}|$  and  $r_{el}$  can be shown to depend on yield and overburden pressure. By using reasonable assumptions for these dependencies, the above equation can be evaluated for a number of yields and depths of burst. Such a parameter study can then be used to evaluate, as a function of frequency, the scaling exponents in relations of the type

$$\frac{Z_1(\omega)}{Z_2(\omega)} = \left(\frac{W_1}{W_2}\right)^{m(\omega)} \quad (\text{for the same depth of burst})$$

and

$$\frac{Z_1(\omega)}{Z_2(\omega)} = \left(\frac{h_1}{h_2}\right)^{n(\omega)} \quad (\text{for the same yield})$$

Figures 13 and 14 show examples of  $m(\omega)$  and  $n(\omega)$  applicable to deeply buried detonations in sandstone and shale, such as Rulison.

Since in the high frequency limit the PSAA amplitude approaches the ground acceleration, Mueller and Murphy derive the following scaling law for peak surface accelerations:

$$\frac{\hat{a}_1}{\hat{a}_2} = \left(\frac{\omega_1}{\omega_2}\right)^{0.33} \left(\frac{h_1}{h_2}\right)^{0.58}$$

When this relation is used to predict Rulison ground motion based on Gasbuggy observations, the results shown in Fig. 15 are obtained.<sup>17</sup> This figure also shows what the prediction would have been if the depth correction had not been applied. The comparison suggests that the prediction is improved by including the depth correction factor. The details of the spectra are more difficult to predict from the simple scaling theory, as can be seen when the observed Rulison spectra are compared with the predicted ones; where the two disagree, the observed spectra are shifted to higher frequencies than were expected. This situation is shown in Figs. 16 and 17. Some of the discrepancies are most likely due to the detailed geology of the individual recording stations. A refraction survey at critical sites permits the derivation of a frequency-dependent amplification curve<sup>17</sup> which can be used to correct the spectrum predicted for that location.

It is instructive to compare some of the response spectra recorded from explosions with those of a few representative earthquakes. This is done in Fig. 18. This figure shows that the maximum PSAA at 175 km from the 825-kt Greeley detonation is almost a factor of 100 below that recorded at 11 km from the 46-kt Rulison explosion. At periods in excess of about 1 sec, however, Greeley amplitudes are very much larger at 175 km than the 11 km Rulison record. Compared to Greeley, the Rulison spectrum at a distance of 179 km is shifted to higher frequency and, of course, much lower amplitudes. Of the earthquakes shown in this figure, very little damage was caused by the 1966 Truckee, California, quake,

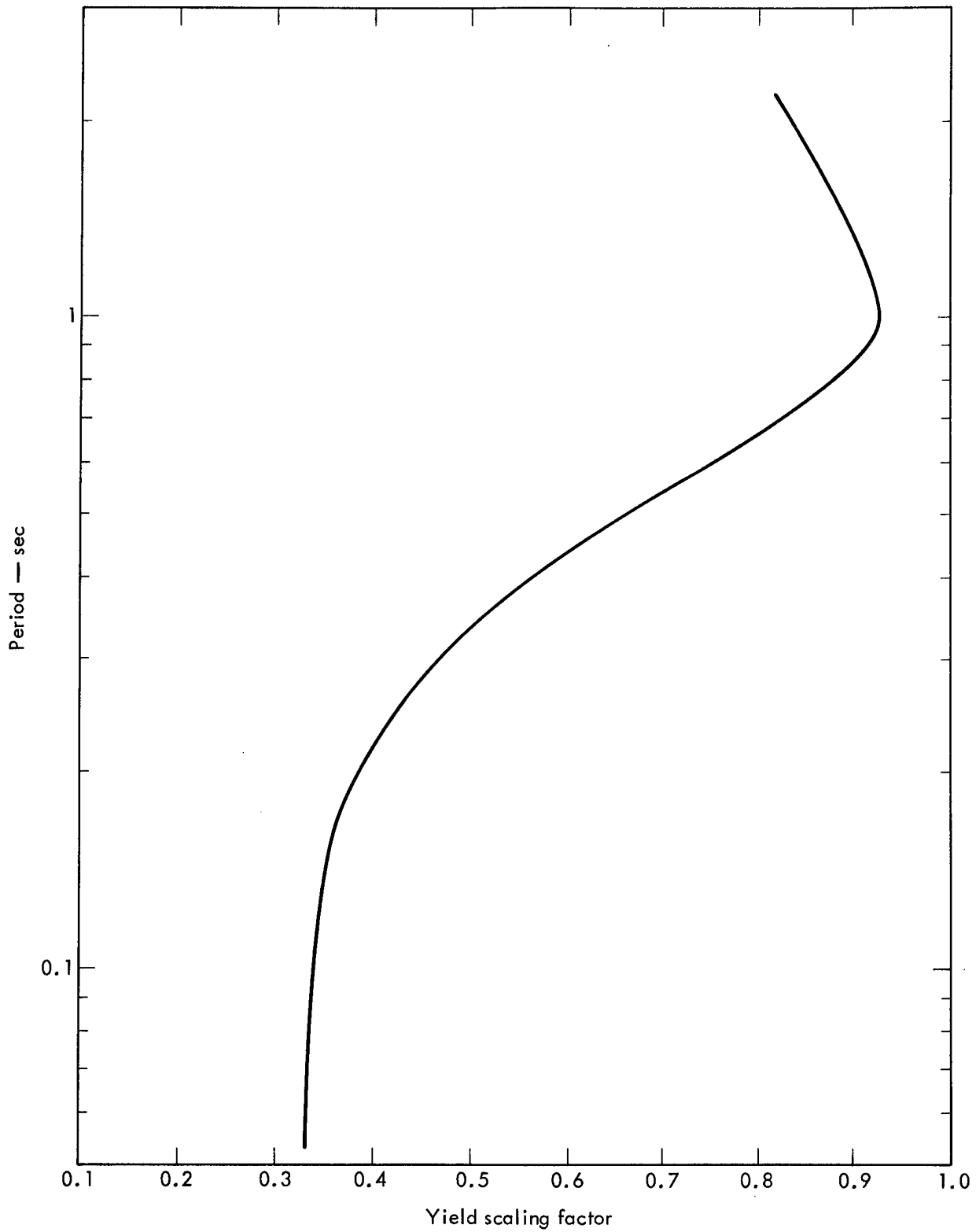

Fig. 13. Frequency dependence of yield scaling exponent.

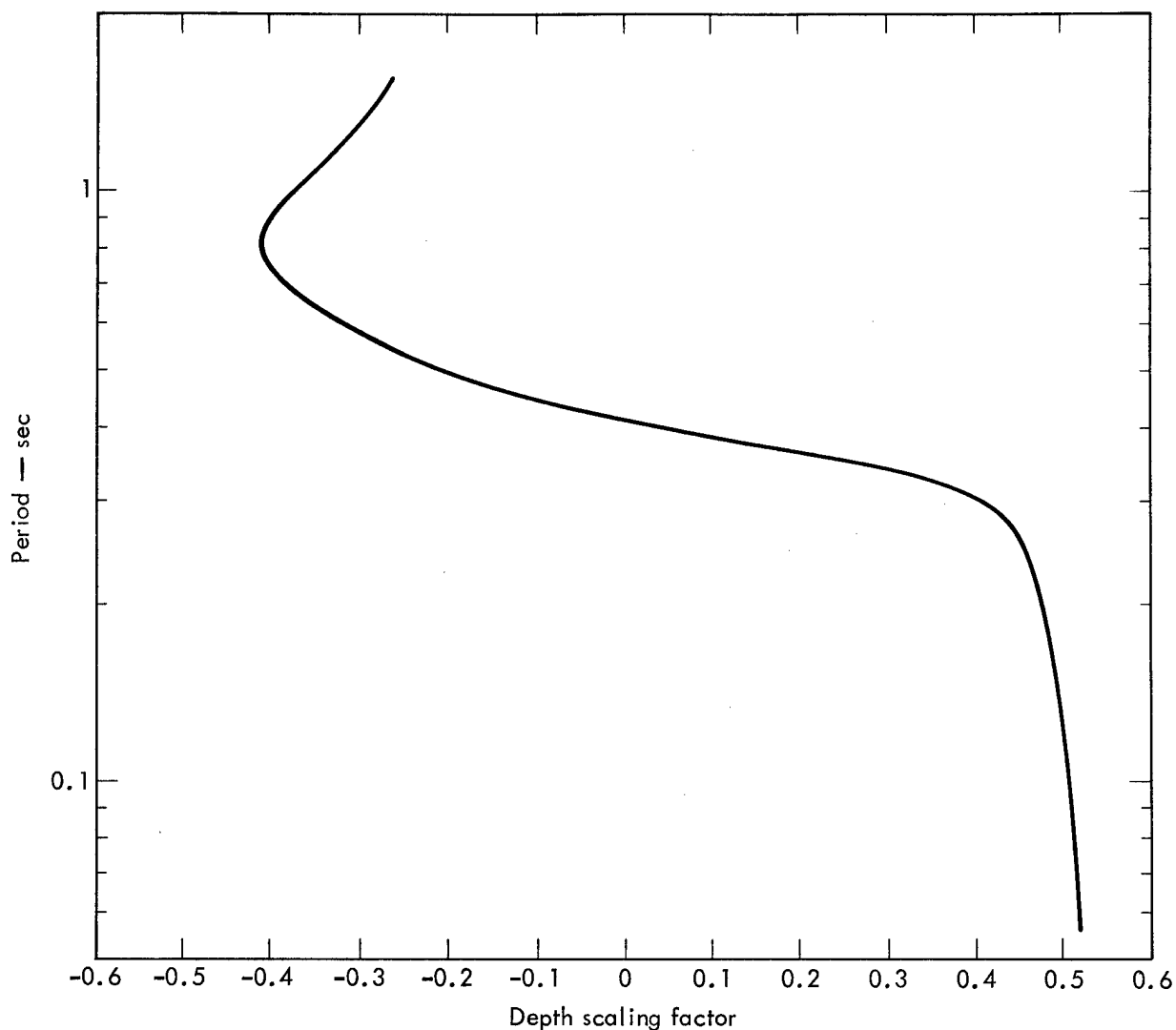

Fig. 14. Frequency dependence of depth scaling exponent.

while considerable damage resulted from the other three shown.<sup>18</sup> For these earthquakes, amplitudes in the resonant frequencies of medium and tall buildings are, of course, very high. The relative displacements also furnish some insight into the degree of damage one might expect from either earthquake or

explosion-induced ground motion. Neither Greeley nor Rulison caused relative displacements in excess of about 1 cm. At those levels, damage should only be architectural in nature. As displacements increase, damage of a more serious nature becomes increasingly likely.

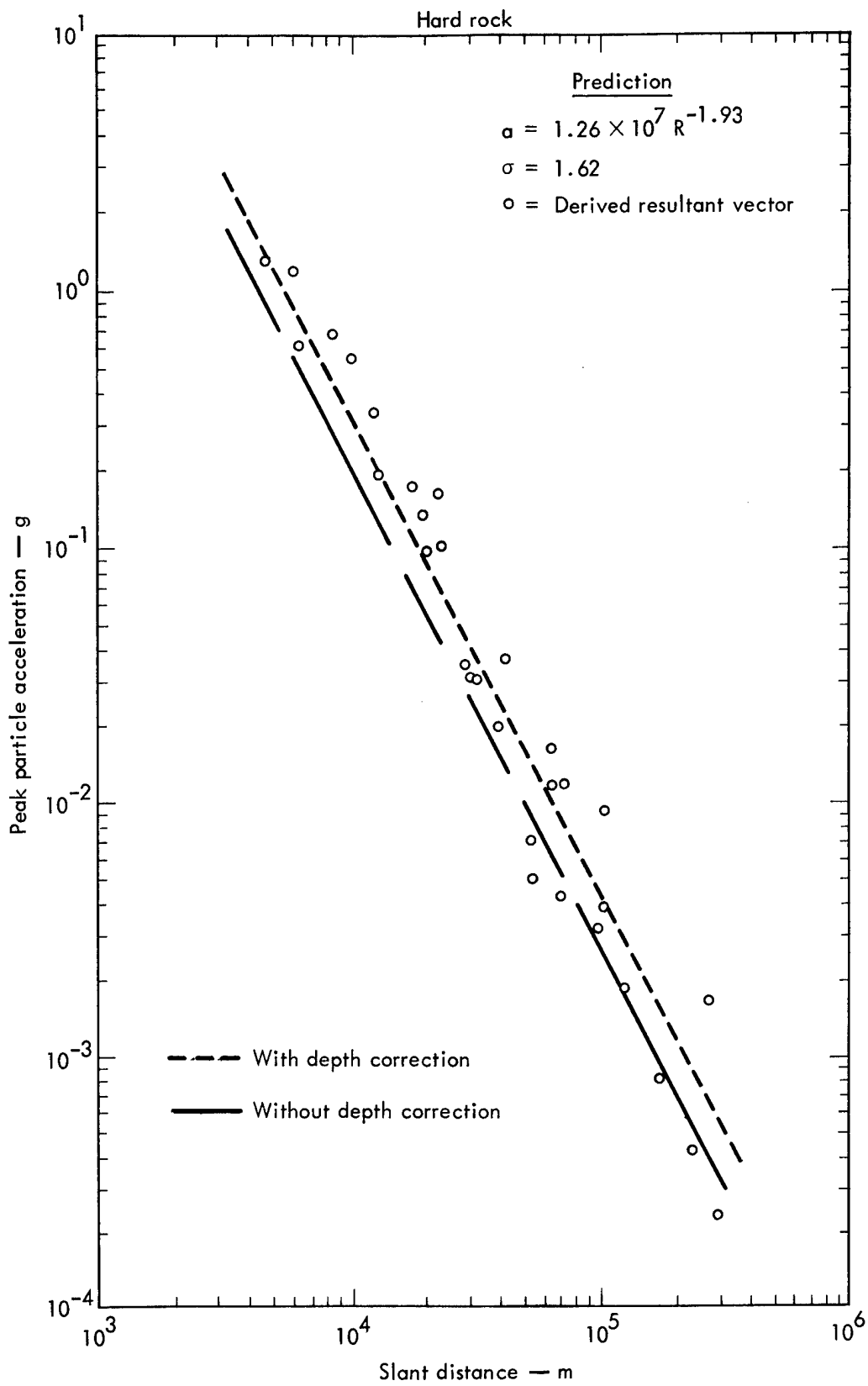

Fig. 15. Comparison of observed and predicted peak surface acceleration—Rulison.

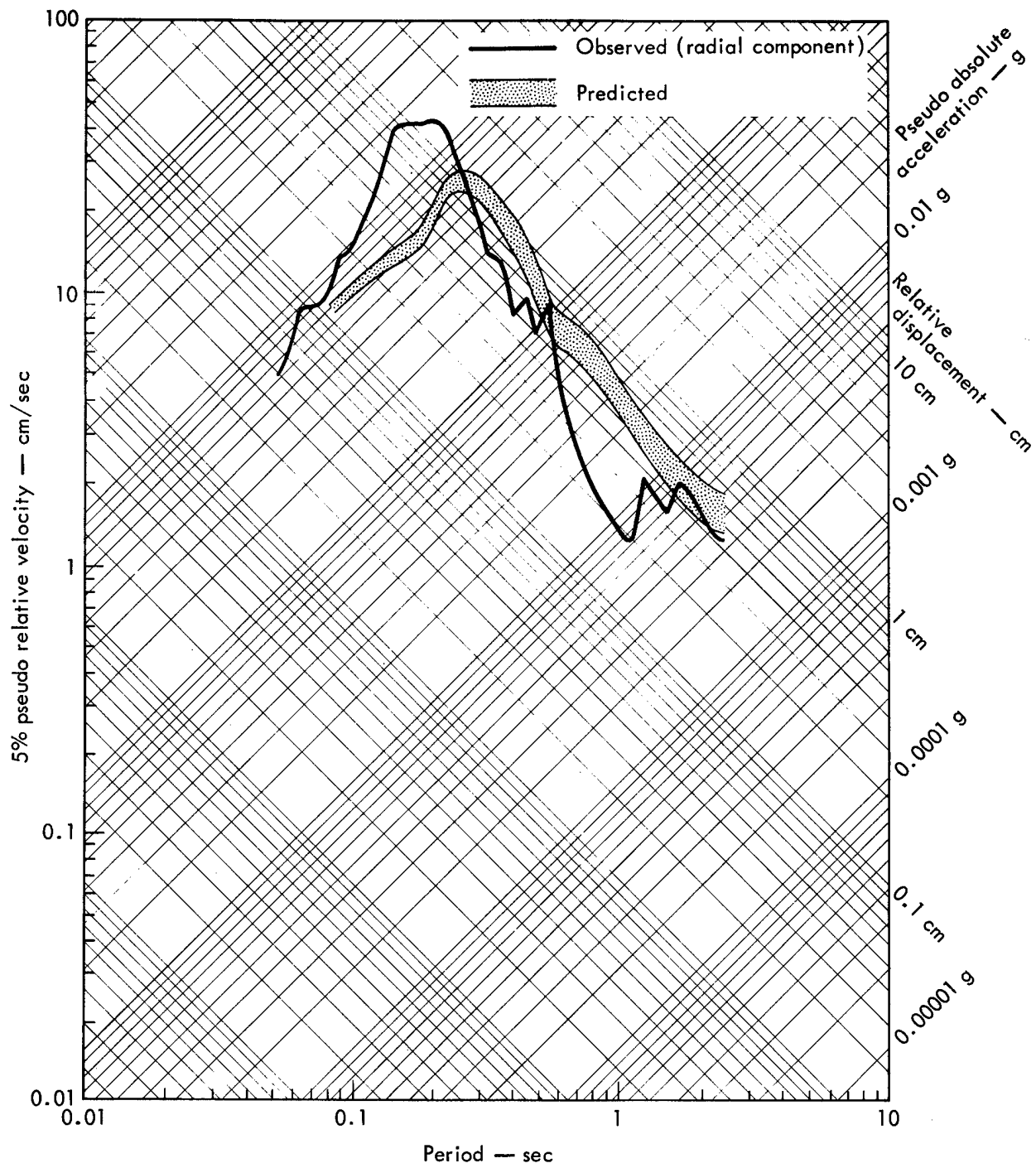

Fig. 16. Comparison of predicted and observed spectrum—Rulison.

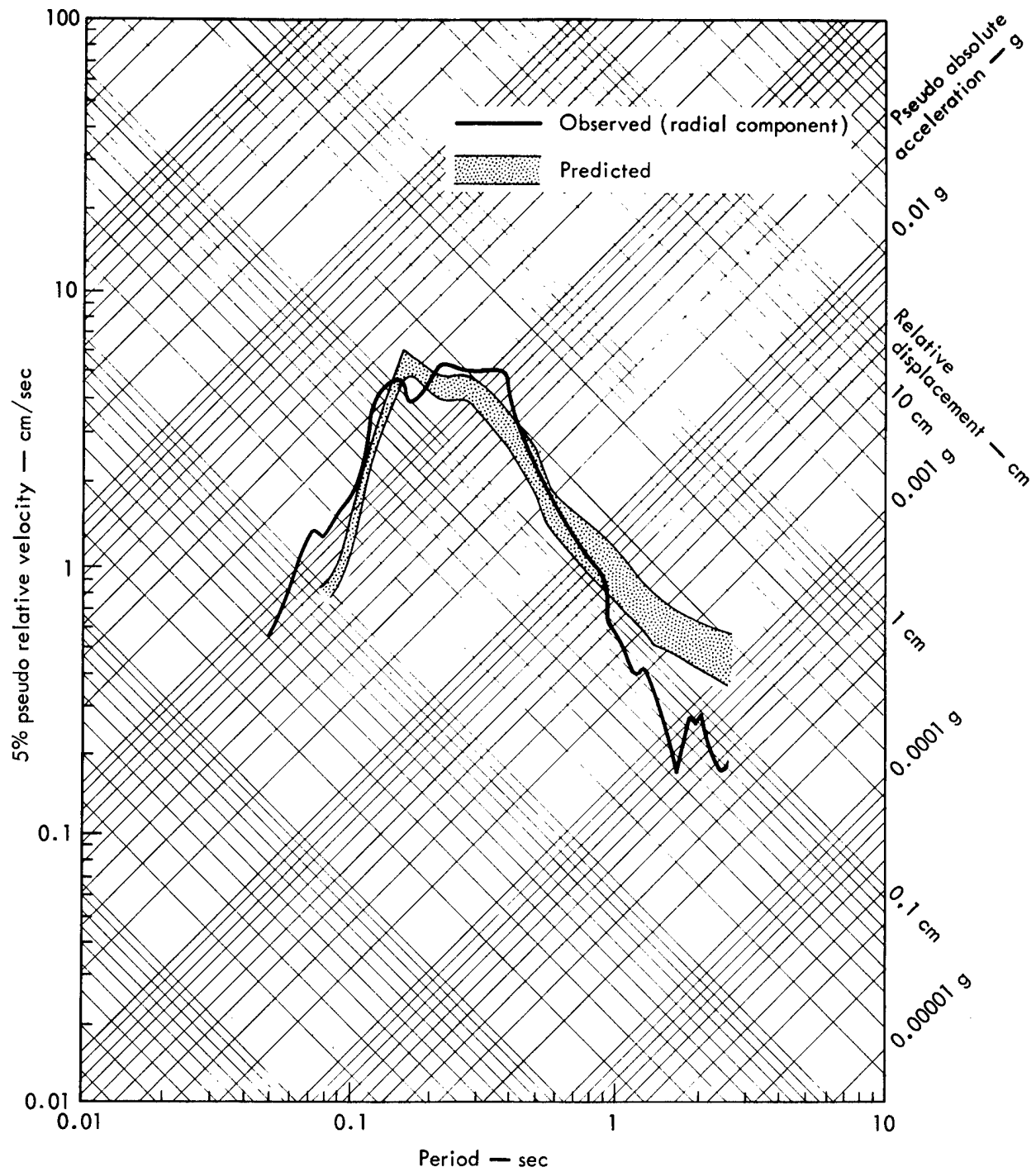

Fig. 17. Comparison of predicted and observed spectrum— Rulison.

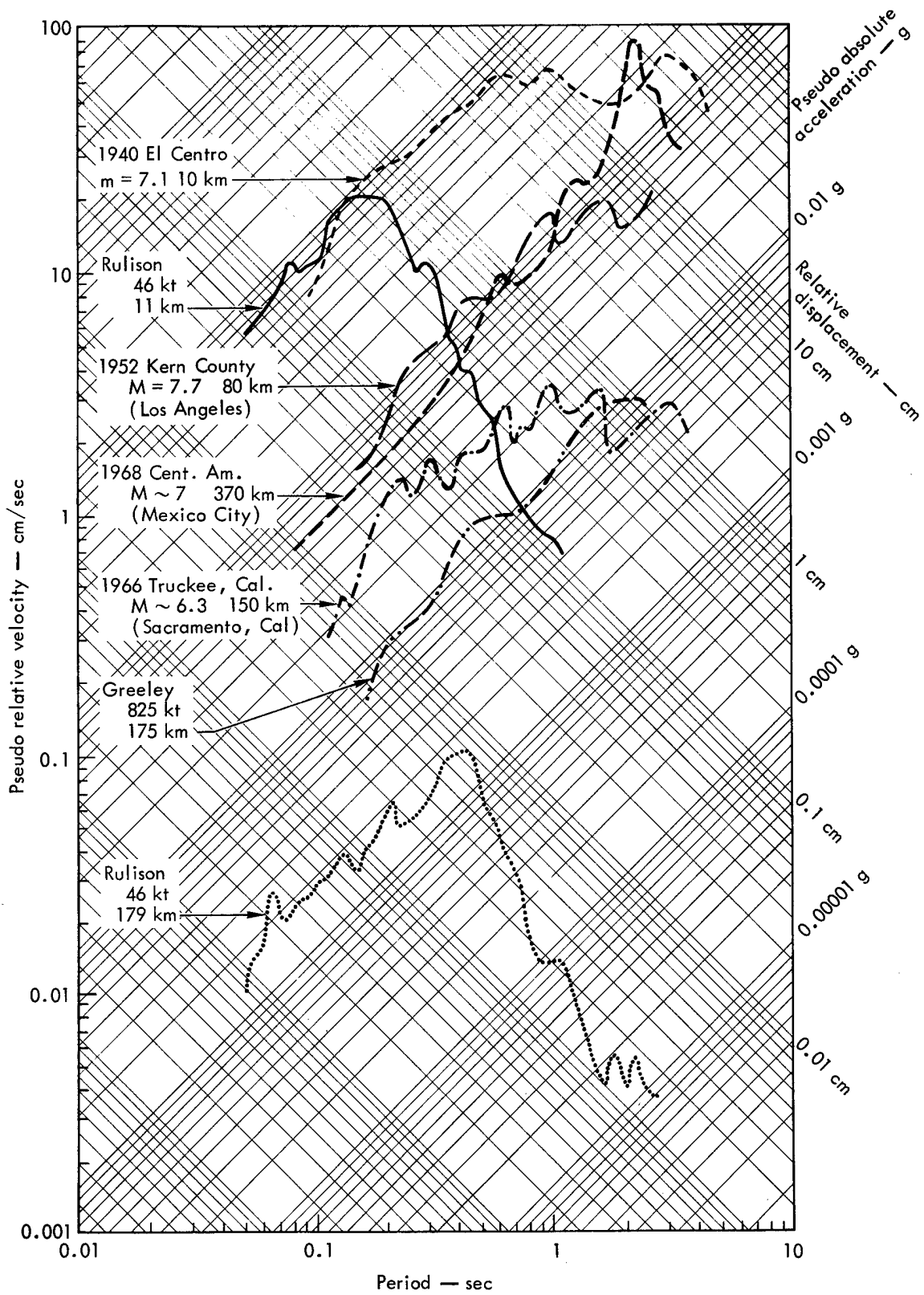

Fig. 18. Comparison of explosion and earthquake spectra.



## Acknowledgments

The many discussions with scientists of the Environmental Research Corporation, Las Vegas, and of J. A. Blume Associates, San Francisco, have always been very helpful. In particular, I wish to thank J. Murphy of ERC for helping me to understand the spectrum scaling theory. R. Scholl of J. A. Blume's Research Division deserves special thanks for making a preprint of his report (JAB-99-59) available, as well as for stimulating and helpful discussions.

## References

1. D. T. Griggs, "Surface Motion from Deep Nuclear Shots," in Industrial Uses of Nuclear Explosives, Lawrence Radiation Laboratory, Livermore, Rept. UCRL-5253 (1958).
2. J. A. Blume, The Spectral Matrix Method of Damage Prediction, AEC Report NVO-99-33 (1968).
3. W. I. Duvall and D. E. Fogelson, Review of Criteria for Estimating Damage to Residences from Blasting Vibrations, U.S. Bureau of Mines Report 5968 (1962).
4. L. J. Cauthen, Survey of Shock Damage to Surface Facilities and Holes Resulting from Underground Nuclear Detonations, Lawrence Radiation Laboratory, Livermore, Rept. UCRL-7964 (1964).
5. D. V. Power, "A Survey of Complaints of Seismic-Related Damage to Surface Structures Following the Salmon Detonation," Bull. Seis. Soc. Amer. 56, 1413 (1966).
6. J. F. Wall, "Seismic-Induced Architectural Damage to Masonry Structures at Mercury, Nevada," Bull. Seismol. Soc. Amer. 57, 991 (1967).
7. M. E. Nadolski, "Architectural Damage to Residential Structures from Seismic Disturbances," Bull. Seismol. Soc. Amer. 59, 487 (1969).
8. R. W. Clough, "Earthquake Response of Structures" in Earthquake Engineering, R. L. Wiegell, Ed. (Prentice-Hall, New York, 1967).
9. Observed Seismic Data, Rulison Event, AEC Report NVO 1163-197 (1969).
10. Structural Response Studies for Project Rulison, AEC Report JAB 99-78 (1971).
11. G. C. Rizer, A Method for Predicting Seismic Damage to Residential-type Structures from Underground Nuclear Explosions, Lawrence Radiation Laboratory, Livermore, Rept. UCRL-50959 (1970).
12. I. Farhoomand and R. E. Scholl, Statistical Correlation of Observed Ground Motion and Low-Rise Building Damage—Project Rulison, AEC Report JAB 99-59 (1971).
13. J. R. Murphy and J. A. Lahoud, "Analysis of Seismic Peak Amplitudes from Underground Nuclear Explosions," Bull. Seismol. Soc. Amer. 59, 2325 (1969).
14. R. D. Lynch, "Response Spectra for Pahute Mesa Nuclear Events," Bull. Seismol. Soc. Amer. 59, 2295 (1969).
15. R. W. Klepinger, Analysis of Ground Motion and Containment Data—Gasbuggy Event, AEC Report NVO 1163-158 (1968).
16. R. A. Mueller and J. R. Murphy, Seismic Spectrum Scaling of Underground Detonations, AEC Report NVO 1163-195 (1970).
17. R. A. Foote, et al., Analysis of Ground Motions and Close-in Physical Effects, Rulison Event, AEC Report NVO 1163-206 (1970).
18. J. A. Blume and R. A. Skjei, Seismic Motion Thresholds for Damage to Structures, presented at the Seismological Soc. of America Annual Meeting, Riverside, California, 1971.

## Distribution

### LRL Internal Distribution

Michael M. May/D. Sewell

R. Batzel

J. Carothers

T. Cherry

P. Coyle

F. Eby

E. Fleming

E. Goldberg

J. Hadley

A. C. Haussmann

W. Harford

G. Higgins

F. Holzer

25

J. Kane

J. Knox

J. Kury

A. Lewis

C. McDonald

P. Moulthrop

W. Nervik

M. Nordyke

50

T. Perlman

D. Rabb

H. Reynolds

H. Rodean

J. Rosengren

B. Rubin

J. Shearer

B. Shore

E. Teller

J. Toman

R. LaFrenz

G. Werth

C. Groseclose

L. Schwartz

L. Crooks/E. Harp, Mercury

TID Berkeley

TID File

30

### External Distribution

J. S. Kelly

50

Division of Peaceful Nuclear

Explosives

Washington, D. C.

TID-4500, UC-35,

243

Nuclear Explosions—

Peaceful Applications