

ARMY REPORT:

Research and Development: Enabling Transformation

OCTOBER 2000

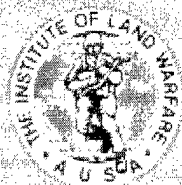

DISTRIBUTION STATEMENT A
Approved for Public Release
Distribution Unlimited

DTIC QUALITY INSURED 4

20001020 099



Contents

- 3 Introduction
- 4 The Desert Storm Force: A Legacy of Research and Development from the 1970s and 1980s
- 6 The "Peace Dividend" Leads to the "Death Spiral"
- 9 The Transformation Imperative
- 9 The Objective Force and the Future Combat Systems
- 10 Science and Technology: Enabling the Objective Force
- 18 What Must Be Done

Introduction

During the 1990s, defense spending was cut in order to provide a "peace dividend." The United States also embarked on an ambitious national security strategy of global engagement that would see American forces deployed worldwide on an unprecedented scale. Increasingly scarce defense funds were devoted to maintaining current readiness at the expense of investment in research, development and acquisition. Shortchanging future readiness in this way is particularly dangerous in light of the fact that current equipment is wearing out and threats to our national security are changing. Tomorrow's Army will need new capabilities to protect American interests. In recognition of this fact, the Army has unveiled a bold transformation vision designed to counter the full range of emerging threats.

Research and development (R&D) funding cannot continue to fall if the Army is to gain the capabilities it needs to deter future conflicts and fight in a rapidly changing strategic environment. Recent events provide cause for optimism on this issue—Congress roughly doubled the administration's request for funding of Army transformation. However, no single congressional plus-up can reverse the effects of a protracted R&D holiday. The government must sustain the appropriated Army Fiscal Year (FY) 2001 science, technology and development funding levels throughout the Future Years Defense Plan (FYDP).

The Desert Storm Force: A Legacy of Research and Development from the 1970s and 1980s

Throughout the Cold War, the United States and its allies relied on technological supremacy to counter the numerically superior Warsaw Pact military forces poised to strike into Western Europe. This highly successful strategy leveraged America's enduring strategic advantages in the fields of research and development. It also helped to bankrupt the Soviet Union—which had no choice but to attempt to match America's technological advancements—and, in so doing, hastened the end of the Cold War.

Never tested in combat against the Warsaw Pact, America's superior military technology

was finally unleashed during the 1990–1991 Persian Gulf War. The U.S. Army's heavy forces, designed originally to defeat much larger Warsaw Pact armies in Central Europe, performed brilliantly throughout the campaign, demonstrating overwhelming lethality, survivability and adaptability to desert warfare.

The path to success in Desert Storm had actually begun many years before. In the midst of Vietnam and the era of the "hollow" military, and facing a growing Soviet quantitative superiority in Europe, the Army set out to improve dramatically the quality of its conventional forces. Constrained by a limited modernization budget, the Army leadership prioritized carefully, focusing its developmental resources on five programs they considered critical to the future heavy combined-arms force: the M1 Abrams main battle tank, the M2/M3 Bradley fighting vehicle, the AH-64 Apache attack helicopter, the UH-60 Black Hawk utility helicopter, and the Patriot air defense system.



M1 Abrams



M2 Bradley

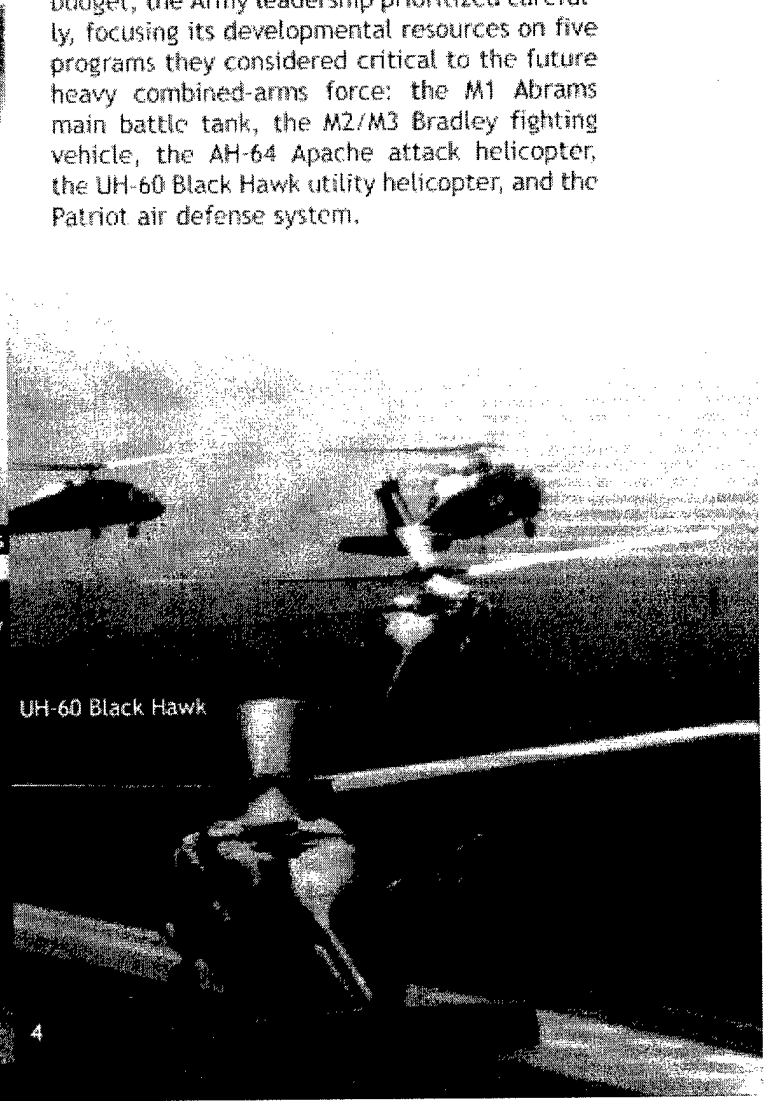

UH-60 Black Hawk



AH-64 Apache



Patriot Air Defense System

Apache proved instrumental in both the air and ground campaigns, often paving the way for ground forces as a tank-killer with its Hellfire missiles, and for air forces with its opening-night attacks on key nodes of Iraq's integrated air defense system. The Army's 101st Airborne Division (Air Assault), transported largely by the Black Hawk, performed the longest-range helicopter assault in history. Armored forces, their skills honed through advanced training simulation at the National Training Center, leveraged the dominant, complementary capabilities of the Abrams tank and Bradley fighting vehicle to deliver a decisive blow to Iraq's elite Republican Guard. All the while, the Patriot antimissile system provided a critical shield—both physical and psychological—against Iraqi Scud missile attacks designed specifically to shatter a potentially fragile coalition and draw Israel into the conflict.

The U.S.-led coalition's margin of superiority over Iraqi forces during Desert Storm would

have been substantially thinner had it not possessed the leap-ahead combined-arms capability provided by the Big Five. Coalition forces likely would have prevailed, but the conflict probably would have lasted longer, and friendly casualties likely would have been higher. However, the seeds of the qualitative superiority that enabled U.S. forces to win quickly, decisively and with astonishingly few casualties were sown well before anyone could have predicted the United States and Iraq would one day come to blows in the Kuwaiti desert. Indeed, the Big Five were made possible by two decades of focused R&D during the 1960s and 1970s when the Department of Defense (DoD) was among the national leaders in R&D investment and had the wherewithal to shape industry and university research to meet national security needs. Today's Army continues to reap the benefits of R&D investments it made some three or four decades ago.

The "Peace Dividend" Leads to the "Death Spiral"

The end of the Cold War led to a strong public demand for a long-promised "peace dividend," and defense budget cuts totaling \$765 billion in the 1990s were the primary bill-payer. Figure 1 traces this dramatic trend that ultimately reduced DoD budgets by 25 percent—the Army budget falling 30 percent—over the course of the decade. The Army force structure would also be trimmed from 18 to 10 active divisions. The other services faced similar reductions to their budget and force structure. The DoD budget as a percentage of gross domestic product (GDP) fell from 5.2 percent to just 3 percent during the 1990s, the lowest such figure since before the 7 December 1941 attack on Pearl Harbor.

During the 1990s, as defense resources were declining precipitously, the United States embarked on an ambitious national security strategy of global engagement that has resulted in an unprecedented and ever-expanding list of worldwide military commitments. While the high operational tempo (OPTEMPO) has been a strain on all of the services, it has affected the manpower-intensive Army disproportionately, with respect to both its people and its equipment. Today the Army must support close to 30,000 soldiers on contingency deployments in

76 nations—in addition to the roughly 120,000 soldiers routinely stationed abroad. Figure 2 illustrates the Army's recent overseas activity and captures the high pace of operations. Since 1993, the Army has averaged one contingency deployment every 14 weeks; in 1989, that figure was one every *four years*.¹

The reduction in Army force structure, shown in table 1, was accompanied by what was intended, at the time, to be a temporary Defensewide "pause" in the procurement of new equipment. The scope of the "procurement holiday" is shown in figure 3.

Initially, DoD was able to lower the average age of its equipment by leveraging the force structure cuts and simply retiring the oldest systems. This might have proven an effective interim measure had procurement resumed as promised. However, the procurement holiday continued throughout the 1990s, forcing the services to rely on equipment longer than planned, often well beyond a system's intended service life. As systems age, they become expensive to operate and maintain. To cover the rising operation and maintenance costs, the services began dipping into the procurement accounts. In order to free up modernization

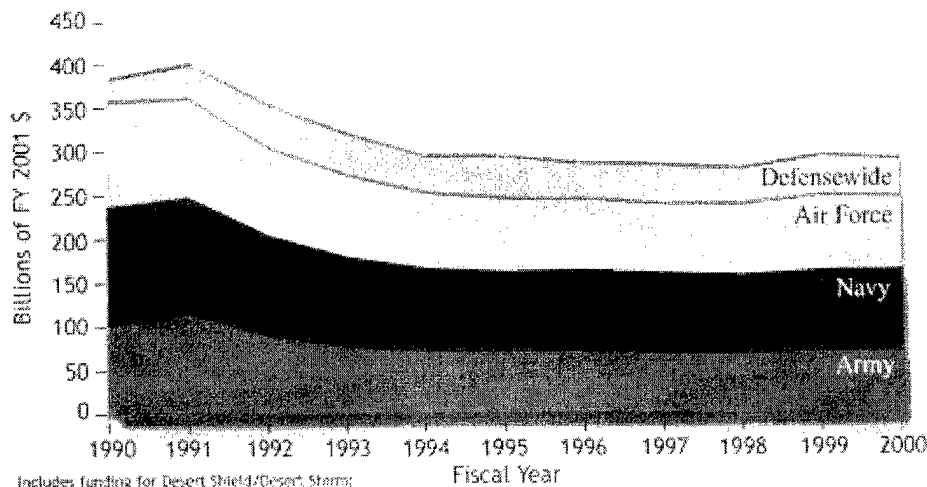

Figure 1
DoD Budget Authority,
FY 1990-2000

Source: Department of Defense

¹ General Eric K. Shinseki, Army Chief of Staff, testimony before the Senate Armed Services Committee's Subcommittee on Airland Forces, 8 March 2000.

On any given day, about 150,000 soldiers overseas

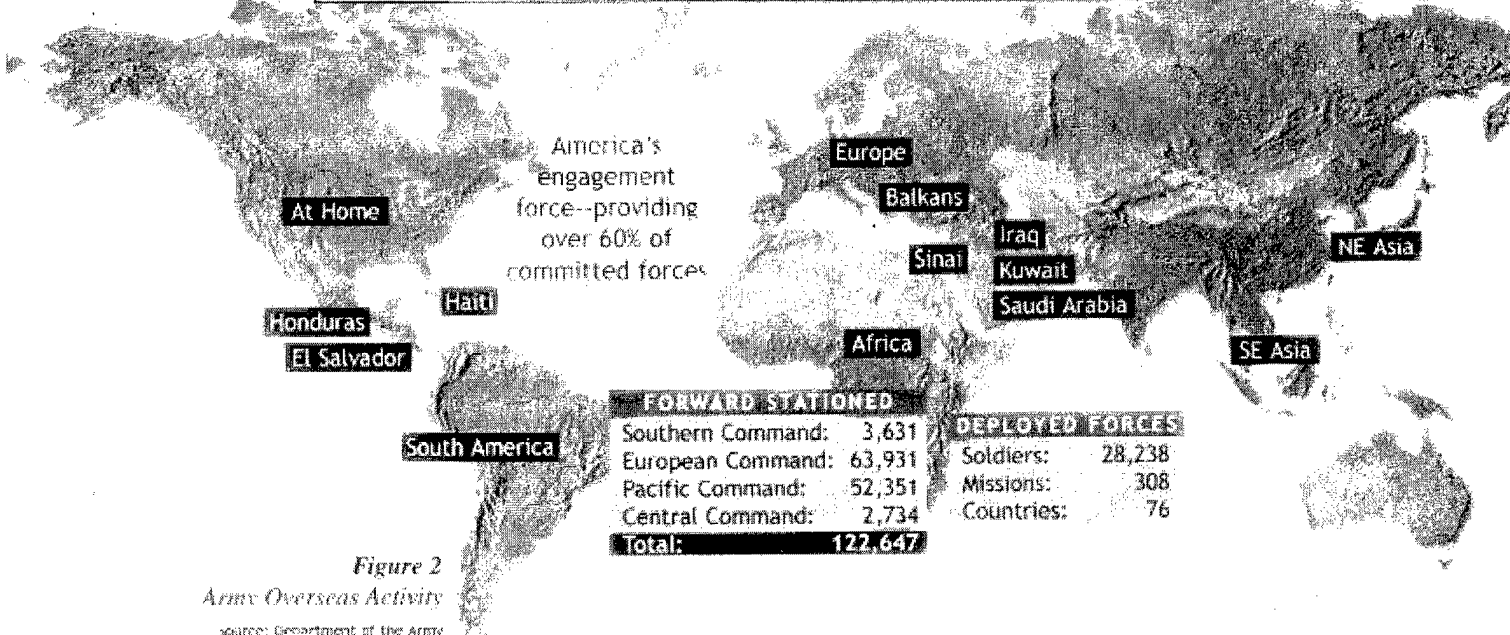

Figure 2
Army Overseas Activity
source: Department of the Army

	FY 1990	FY 2000	% REDUCTION
Active/Reserve Division	18/10	10/8	36%
Active Reserve Separate Brigades	8/27	3/18	40%
Total Active Manpower	750,000	480,000	36%
Total Army Budget	\$102.5 billion	\$71.5 billion	30%
O&M	\$35.939 billion	\$24.651 billion	32%
Personnel	\$42.716 billion	\$28.646 billion	33%
Procurement	\$16.878 billion	\$10.556 billion	38%
RDYBE	\$6.471 billion	\$5.368 billion	17%

Table 1
Peace Dividend and the Army
Source: Department of Defense

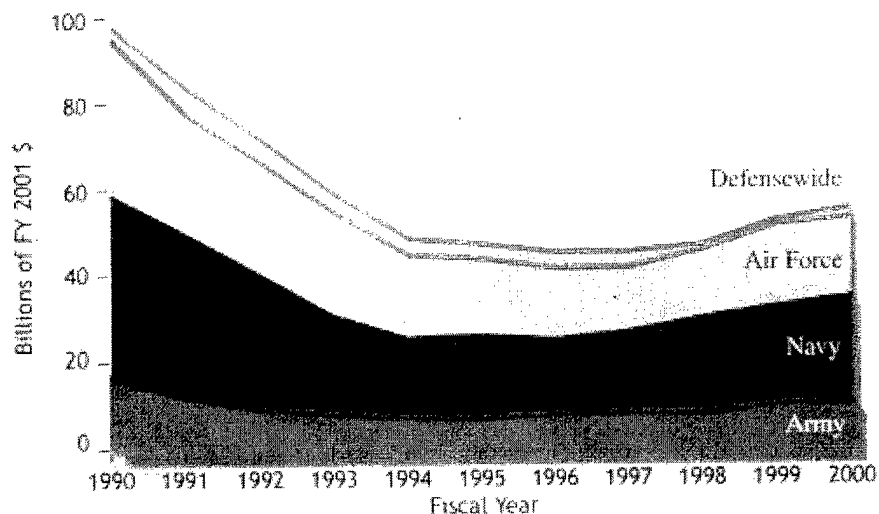

Figure 3
DoD Procurement Spending,
FY 1990-2000
Source: Department of Defense

funds, the services have often deferred the recapitalization of current systems and/or reduced the quantities of new systems purchased. In both cases, but especially the latter, this increases system unit cost and further reduces the number of units procured. The Under Secretary of Defense for Acquisition, Technology and Logistics referred to this vicious, self-predatory cycle as the "death spiral."²

The latest casualty of the defense draw-down-triggered "death spiral" is R&D—the foundation of our technological superiority and, thus, of our global military dominance. Just as the procurement accounts have been raided to maintain and operate aging systems, R&D funding has been siphoned to help pay for both the recapitalization and/or upgrade of legacy systems and the acquisition of new systems in the final phases of development. As illustrated in figure 4, DoD R&D investment declined 13 percent between Fiscal Year (FY) 1990 and FY 2000; Army R&D investment declined 17 percent over the same period.

In addition, the services, seeking to ensure the acquisition of new equipment after the long procurement holiday, are applying a rising percentage of the remaining R&D funding to these near-term priorities (e.g., upgrades to fielded systems and final development work on follow-on systems)—at the direct expense of the development of fundamentally new capabilities. In the President's FY 2000 budget request, for example, more than 33 percent of the total DoD-wide FY 2000 Research, Development, Test and Evaluation (RDT&E) request was for modifications to fielded and, in many cases, aging systems. In that same request, the S&T accounts, which underpin the development of new capabilities, were reduced by nearly 25 percent from 1999.³

The result of R&D reductions and the skewing of investment toward near-term priorities is, in the words of the Defense Science Board, "severely depressed U.S. military-technological innovation when the premium on innovation has never been higher."⁴

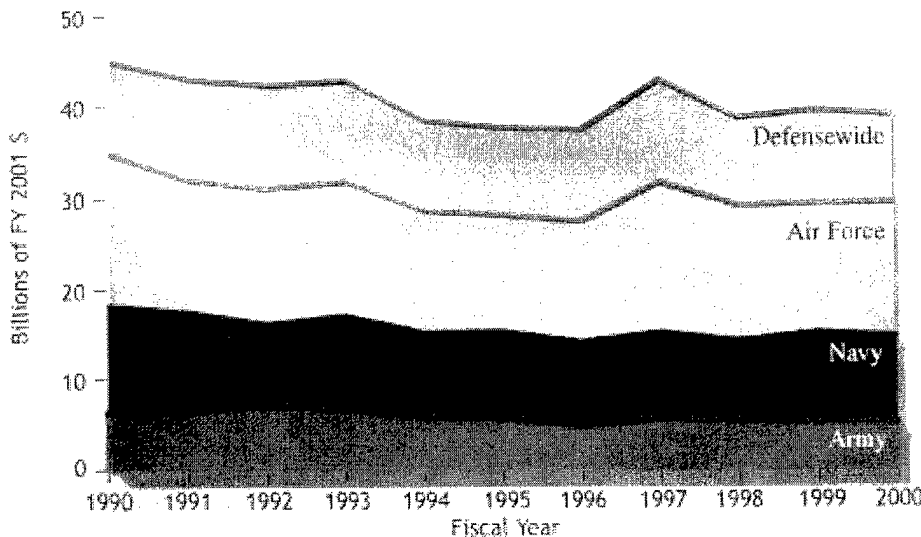

Figure 4
DoD RDT&E Spending,
FY 1990-2000

Source: Department of Defense

² Remarks of Jacques Gansler, Under Secretary of Defense (Acquisition, Technology & Logistics), at AUSA's Battlefield Visualization Symposium, Falls Church, VA, 6 May 1999.

³ Office of the Under Secretary of Defense for Acquisition and Technology, *Final Report of the Defense Science Board Task Force on Globalization and Security*, December 1999, p. 22.

⁴ *Ibid.*, p. 22.

The Transformation Imperative

Why is military-technological innovation more important than ever? The answer is two-fold. First, the globalization phenomenon is leveling the international military-technological playing field, i.e., providing all states, not just the great powers, with access to much of the technology (both defense-unique and commercially developed) underpinning the modern military. Consequently, the United States must "run" even faster—accelerate the development of tomorrow's technology—to stay ahead of its competitors.

Second, America's potential adversaries are leveraging their newfound access to militarily useful technology to present U.S. forces with a fundamentally new set of threats designed not to match our strengths, but rather to exploit our vulnerabilities. Specifically, potential adversaries will seek to capitalize on the great distances U.S. forces must travel to engage them, and on U.S. forces' reliance on unimpeded access to and use of ports, airfields, bases, littoral waters and airspace in the theater of conflict. Gone are the days of six-month theater force buildups, uncontested access to the theater, and operational sanctuary once in-theater. Tomorrow's adversaries are expected to attack with little or no warning, and to attempt to

physically deny U.S. forces access to the theater with a wide range of so-called "anti-access" forces such as ballistic and cruise missiles and weapons of mass destruction.

Meeting these new challenges requires U.S. forces to adopt a dramatically different approach to warfare. It also requires a new Army—a dramatically more responsive and survivable force able to deploy decisive combat capability to a theater in days rather than months, and to operate effectively in an increasingly threatening environment. Tomorrow's Army must be capable of more than just prevailing in major theater warfare. To continue supporting a national security strategy of global engagement, our Army must retain the ability to respond effectively at the "lower" end of the contingency spectrum, which is characterized by increasingly frequent humanitarian, peacekeeping and peace enforcement operations. In short, the nation demands an Army that is strategically responsive and dominant at every point on the spectrum of operations and capable of providing the National Command Authorities with a broad range of options for peacetime operations, deterrence and warfighting.

The Objective Force and the Future Combat Systems

To provide such a force within the shortest possible time frame, the Army, under the leadership of Chief of Staff General Eric K. Shinseki, has embarked on an ambitious transformation strategy. The new Army Vision, released in February 2000, calls for an Army capable of placing a combat brigade anywhere in the world within 96 hours; a division into theater within 120 hours; and five divisions within 30 days.

The central goal of this "Objective Force" is to achieve this level of responsiveness without sacrificing either lethality or survivability. A parallel goal is to substantially reduce the Army's theater logistics "footprint"—the size and weight of its theater deployment—in order to reduce its dependence on large theater bases (and thus its vulnerability to enemy anti-access strategies) and to minimize strategic lift

requirements. General Shinseki, in a recent address, captured the essence of the Army's transformational challenge:

We must provide early-entry forces that can operate jointly without access to fixed forward bases, but we still need the power to slug it out and win decisively. Today, our heavy forces are too heavy and our light forces lack staying power. We will address those mismatches.⁵

The centerpiece of the Objective Force is the Future Combat Systems (FCS) family of vehicles, now in the very early stages of development. As currently envisioned, the FCS will be capable of multiple roles, overwhelming lethality, strategic deployability, self-sustainment, and very high survivability on tomorrow's high-threat battlefield—a true "system of systems" in which the individual soldier is a critical component. With these attributes, FCS

impact on Army warfighting capability in the 21st century could well be as significant as the introduction of the tank during World War I and the attack helicopter in Vietnam. Goals for the FCS 20-ton combat vehicle include:

- light weight (less than 20 tons) for C-130 transportability;
- a 33–50 percent decrease in logistics sustainment requirements and a 50 percent decrease in fuel consumption;
- a continental United States (CONUS)-to-theater response time of less than 96 hours;
- the ability to sustain OPTEMPO for five days without resupply; and
- very high battlefield speeds (100-kilometers-per-hour burst; 60-kilometers-per-hour sustained cruise).

Science and Technology: Enabling the Objective Force

DoD invests in S&T to (1) develop technology solutions to known military needs and (2) develop technologies that may have substantial military potential, but whose ultimate military application is yet to be defined. In the case of the Objective Force and the FCS—the embodiment of the land force the Army again knows the nation requires—the military need could not be clearer.

With the majority of the technology underpinning the FCS yet to be developed, the success of the Army's bold transformation strategy rests squarely on the shoulders of the Army S&T community, in partnership with the Defense Advanced Research Projects Agency (DARPA). Indeed, Army transformation efforts will focus on S&T until the FCS-enabling technologies have matured to the point where the development of systems with the above-described characteristics can begin in earnest. Today, the S&T com-

munity is working hard to answer such critical technical questions as:

- How can the armored volume of a combat vehicle be reduced while its survivability is increased?
- How can FCS deployability be increased beyond today's standards without sacrificing its survivability and lethality?
- How can the Army reduce in-theater support needs, and thereby reduce strategic lift requirements?

These and other questions are guiding a major effort to develop technologies that will give the Objective Force its desired characteristics—responsiveness, agility, versatility, deployability, lethality, survivability and sustainability. The Army and DARPA have combined resources of \$500 million per year to define and

⁵ Army Chief of Staff General Eric K. Shinseki, Remarks at Chief of Staff Arrival Ceremony, Fort Myer, VA, 23 June 1999.

explore the FCS concept in time for the Chief of Staff (CSA) to decide in 2003 whether the technology will support realization of the FCS-equipped Objective Force.

Focused investment of scarce S&T funds should provide the development of the minimum essential component technologies needed to support the on-schedule start of FCS development. Highlighted in the following section are some of the most promising advanced technologies and systems:

Lethality

Guided Multiple Launch Rocket System—Extended Range (GMLRS-ER)

- Increased range, accuracy and lethality
- Global Positioning System (GPS)/inertial guided (10m Circular Error Probable [CEP])
- 60km maximum range



High Mobility Artillery Rocket System (HIMARS)

- Lightweight version of the Multiple Launch Rocket System (MLRS) launcher
- Roll-off C-130 and operational in 15 minutes
- Capable of firing any rocket or missile in the MLRS family of munitions



Net Fires

- "Missiles in a box"
- 20–40km precision attack munitions
- 30-minute/200km loitering attack munitions
- Fully autonomous



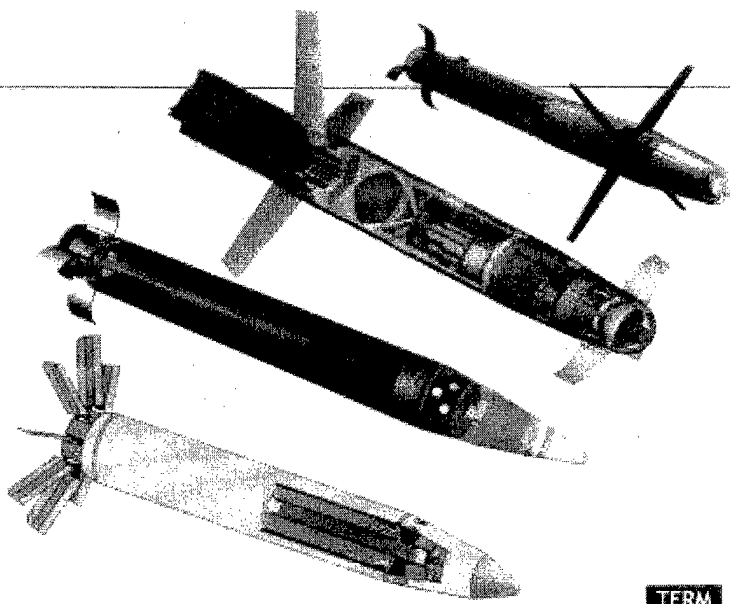

Tank Extended Range Munition (TERM)

- Fully integrated gun-launched precision munition capable of defeating high-value threats, advanced armor threats equipped with explosive reactive armor, or active protection systems out to 8km line of sight (LOS) and non-LOS
- Leverage targeting information available from forward observers and reconnaissance, surveillance and target acquisition (RSTA) platforms
- Seven-fold increase in lethal battlespace

TERM

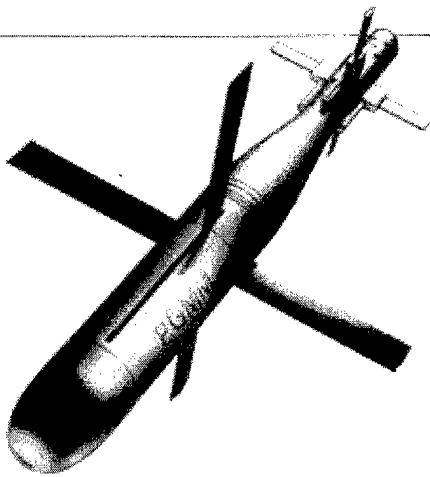

Precision Guided Mortar Munition (PGMM)

- Responsive, stand-off precision indirect fire weapon
- 120mm laser-guided mortar
- Accurate (one meter CEP), extended range (15km) and lightweight (less than 40lb)
- 10-fold increase in indirect fire kills
- 40 percent reduction in rounds fired for reduced logistics burden

PGMM

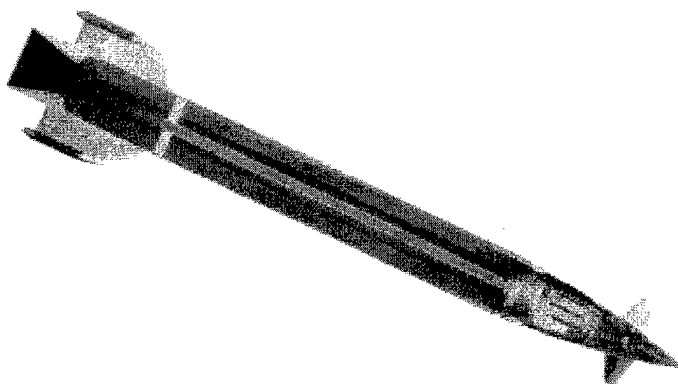

Compact Kinetic Energy Missile (CKEM)

- Compact (4ft long; 35–40kg) hypervelocity (Mach 6.5 @ 500m) kinetic energy missile
- Low vulnerability propellant
- Capable against air & ground targets to 5km
- Greater than 10 mega-joules (MJ) penetrator energy over a range of 0.4–4.0km
- Missile delivers greater than 30MJ on target at 4km
- Compatible with the line-of-sight antitank (LOSAT) target acquisition and tracking system

CKEM

Electro-Thermal Chemical (ETC) Gun with Novel Kinetic Energy Penetrator

- Improved direct-fire lethality
- Potential to achieve 120mm performance in a 105mm cannon at less weight, cost and logistics burden
- High-energy, high-density propellant formulations and geometry
- Plasma generators for effective coupling of electrical energy into propellants

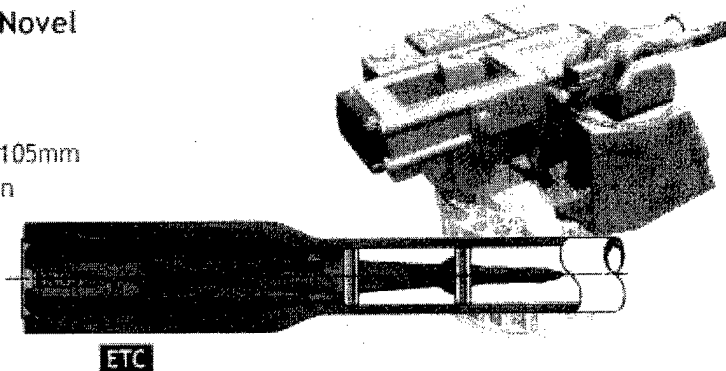

Objective Crew-Served Weapon

- Integrated 25mm machine gun system with air bursting munitions
- Light-weight system with crew of two
- Suppresses infantry at ranges up to 2km
- Damages lightly armored vehicles, watercraft, and slow-moving aircraft at ranges up to 1km



Survivability

Integrated Survivability with Active Protection System

- Emphasis on layered defense: avoiding being detected, acquired, hit, penetrated and killed
- Destroy or degrade chemical and kinetic energy antiarmor munitions prior to vehicle impact
- Exploit aircraft survivability approach and technologies
- Reduces dependence on heavy armor

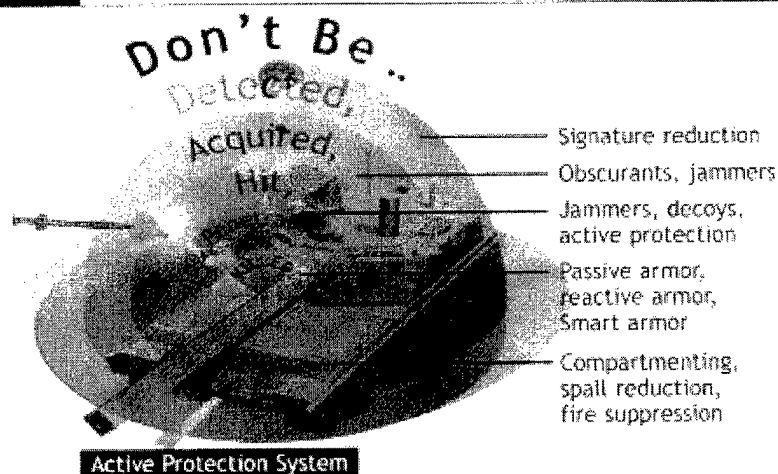

Lightweight Passive Armor

- Electromagnetic armor
- Smart armor
- Explosive/energetic armor
- Advanced materials and composites

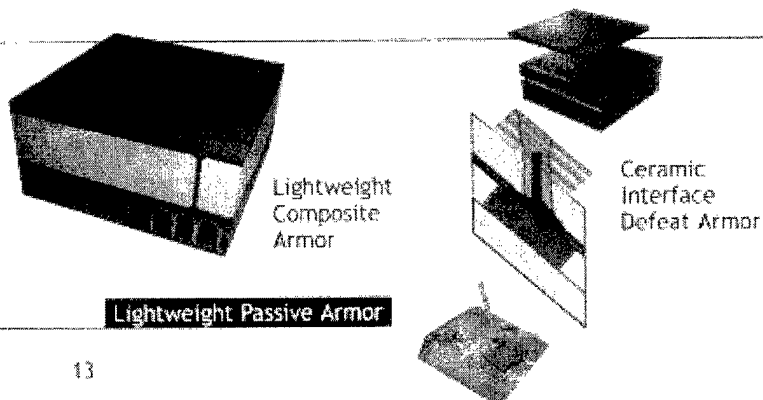

Mobility-Deployability

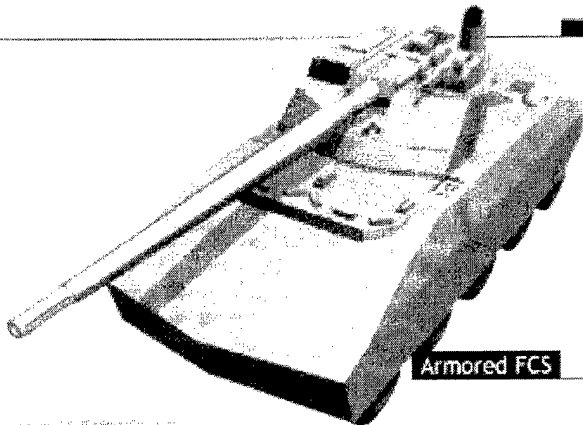

Armored FCS

20-Ton Armored FCS Vehicle

- C-130 transportable
- Advanced lightweight armor
- Composite vehicle structure 33 percent lighter than comparable steel or aluminum

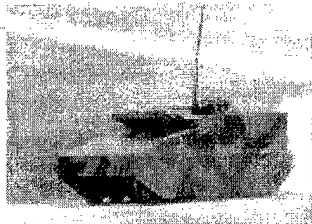

Composite Armored Vehicle

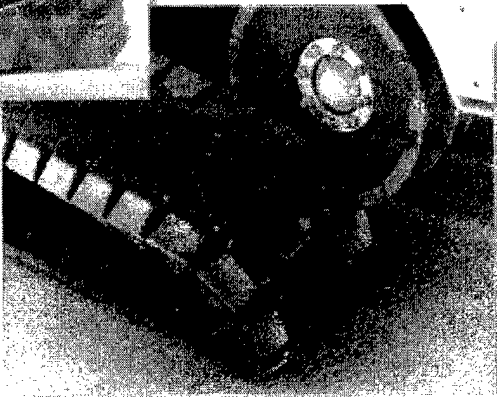

Band Track

Ground Propulsion and Mobility

- Combined enhancements of semiactive suspension, band track and electric drive
- Reduces overall vehicle weight, decreases "under armor" volume, and improves mobility by 30 percent, compared to Abrams
- Band track reduces acoustic and infrared (IR) signatures by 30-50 percent and track weight by 20 percent, compared to Abrams
- Electric drive reduces signatures (acoustic and IR) and provides power management scheme for range of electric systems: armament, sensors, active suspension

Ground Propulsion & Mobility

Advanced Propulsion

- High power density, low heat rejection, fuel efficient engine
- Compact, high-efficiency drive train
- Capable of 60mph cross-country, an increase of 40 percent
- Reduce fuel demand by 50 percent

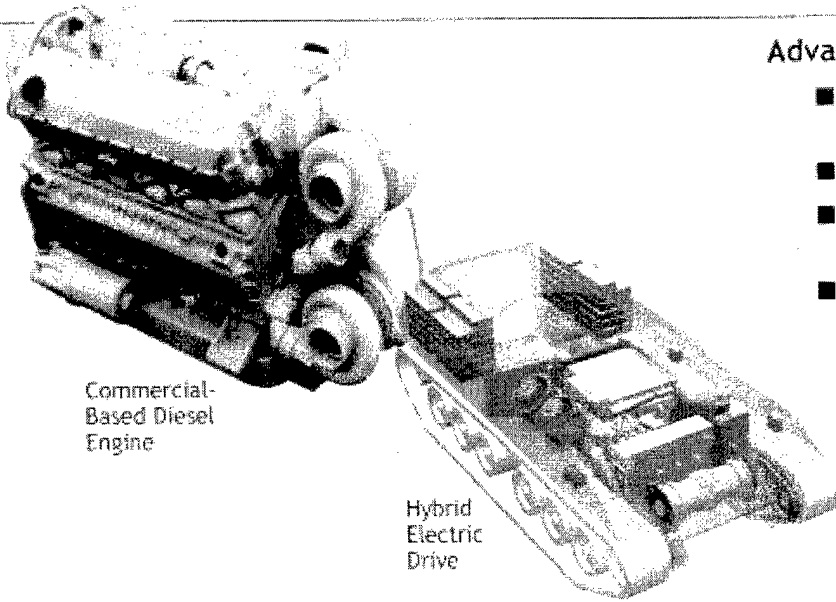

Commercial-Based Diesel Engine

Hybrid Electric Drive

Advanced Propulsion

C⁴ISR

(Command, Control, Communications, Computers, Intelligence, Surveillance and Reconnaissance)

Family of Unmanned Aerial Vehicles (UAVs)

- Networked to Comanche and FCS to expand battlespace and improve force survivability, lethality and tactical mobility
- Range from high-altitude systems such as Global Hawk to mini- and micro-UAVs organic to FCS force
- Vertical takeoff/landing UAVs provide small logistic footprint and silent over watch

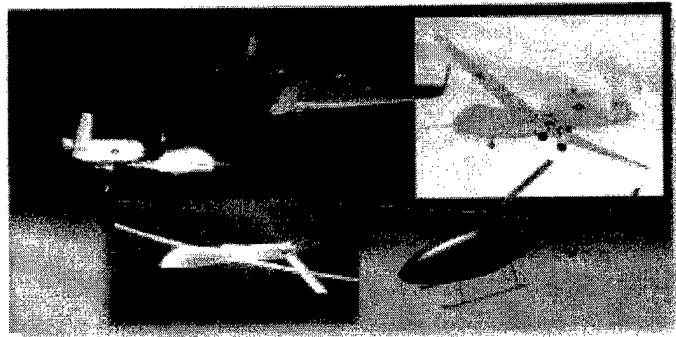

UAVs

Secure, Mobile, Wireless C⁴ISR "Infosphere"

- Network-centric collaborative force
- Dominant battlespace awareness
- Secure, mobile infosphere
- Advanced sensors
- Rapid battlespace visualization and damage assessment

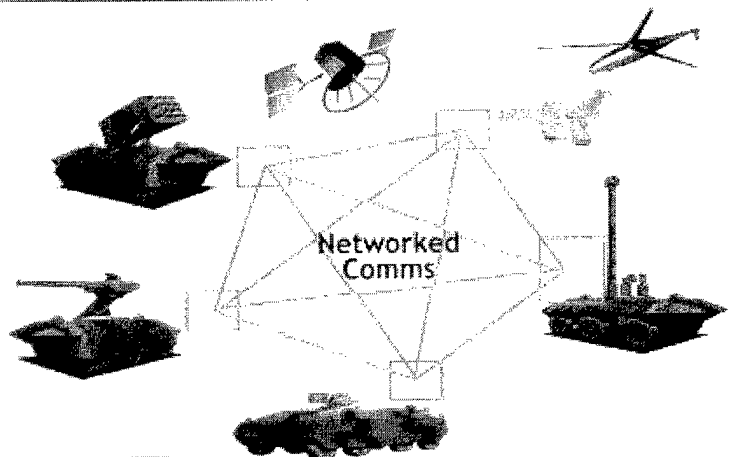

C⁴ISR Infosphere

Crewman's Associate

- Expert systems and artificial intelligence for 50 percent reduction in crew workload
- Leverages Rotorcraft Pilot's Associate (RPA)

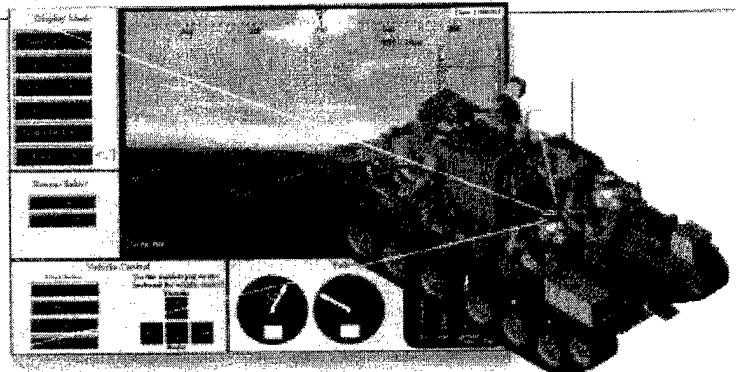

Crewman's Associate

Sustainability

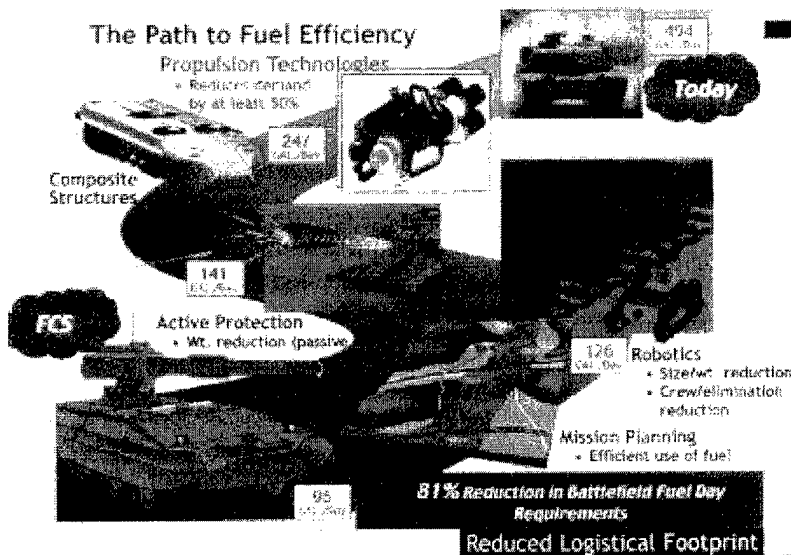

Reduced Logistical Footprint

- FCS-equipped force requires at least 50 percent less support than the Abrams force
- Robotics: Size/weight reduction, crew elimination/reduction
- Battlefield fuel day requirements reduced 80 percent
 - Mission planning: efficient use of fuel
 - Active protection vs. passive protection (armor)
- Propulsion technologies

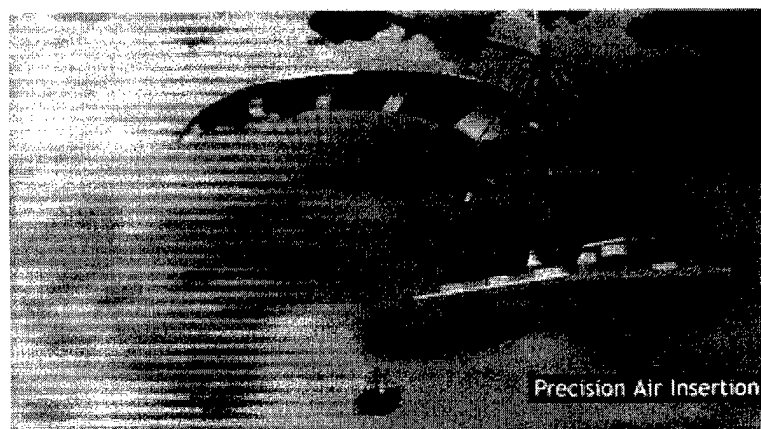

Precision Air Insertion

- Autonomous precision air insertion of payloads up to 21 tons
- High-altitude delivery with 20km offset and 100m CEP
- GPS-guided

Unfortunately, due to the decade-long R&D decline, FCS program risk will be higher, and a number of high-payoff technologies may not be available in time for the start of FCS

development in 2006. Examples of capabilities at high risk of not being ready for FCS 2006 engineering, manufacturing and development start due to R&D reductions of last decade include:

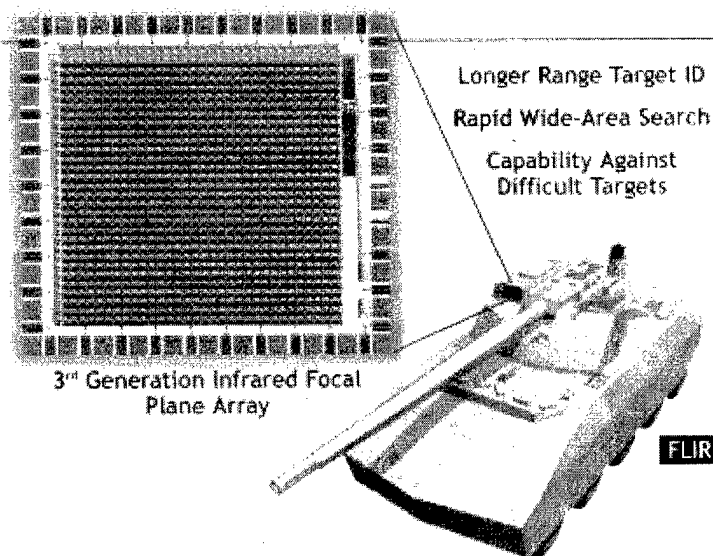

Affordable Third-Generation Forward-Looking Infrared (FLIR)

- Producing large staring arrays, which will operate with high sensitivity at higher operating temperatures
- Multicolor focal plane arrays
- SMART read-out circuits enabling on-chip processing
- Advanced electronics for advanced, high-speed signal and image processing

MLRS Smart Tactical Rocket (MSTAR)

- Terminally-guided MLRS with smart submunitions
- Candidate submunitions: Brilliant Anti-Armor Technology (BAT) P¹, Sense and Destroy Armor Munition (SADARM), and Damocles
- GPS guided for 10m CEP
- Reduces logistic support, resupply, maintenance, and number of launchers through efficiency of delivery

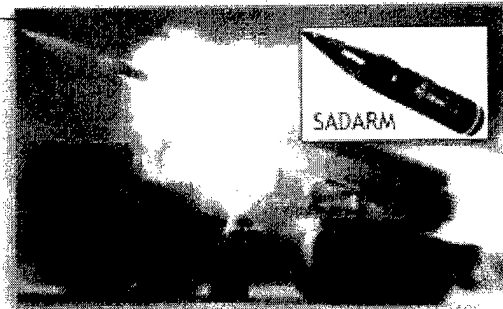

MSTAR

Autonomous Unmanned Ground Vehicles (UGVs)

- Includes: tactical, unmanned shooter platforms, robotic seekers, robotic sensors
- Manned control platform responsible for command and control

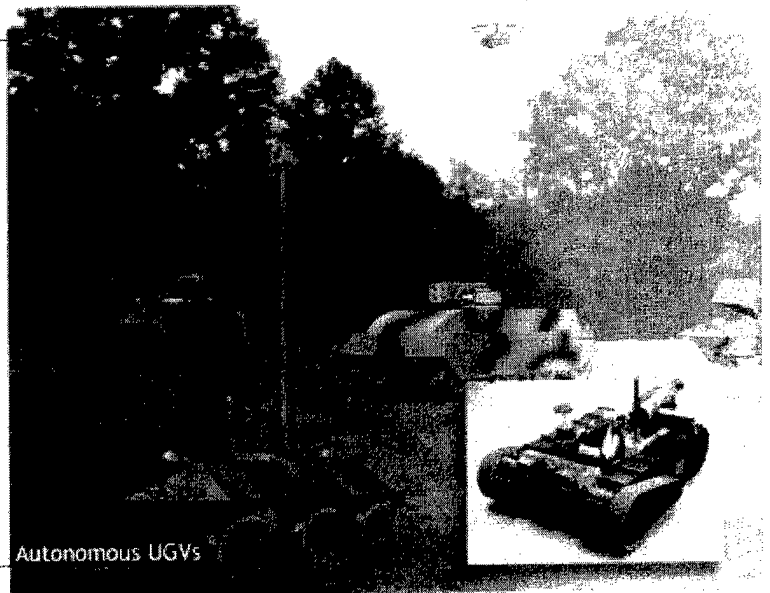

Joint Transport Rotorcraft

- Speed, payload and range for forced entry and deep operations
- Vertical lift and tactical mobility of C-130 payloads including FCS
- Self-deployable
- Enables vertical envelopment of the enemy by FCS force
- Enables the FCS force to prevent enemy set and to perform synchronized attack of multiple centers of gravity
- Provides capability for logistics over the shore of standard military vans

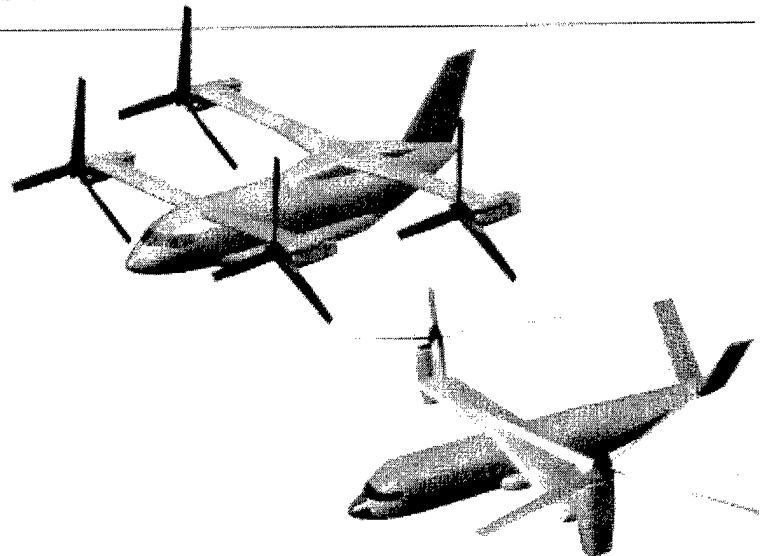

Joint Transport Rotorcraft

What Must Be Done

If the services—and the Army in particular—are to transform successfully to meet emerging challenges, the government must *immediately* reverse the decade-long decline and stabilize defense R&D investment. This year, Congress took a bold step in the right direction, adding \$3.3 billion in R&D funding to the President's FY 2001 DoD budget request, \$1.1 billion of which will go to the Army. Figure 5, which plots Army R&D funding through 2001, helps illustrate the scope of the increase. Congress also appropriated \$1.6 billion for Army transformation, roughly doubling the administration's request.

However, no single congressional plus-up can reverse the effects of a protracted R&D holiday. Nor can the services count on Congress to continue redressing the R&D deficiencies in the President's budget request. The administration's Future Years Defense Plan, highlighted in figure 6, must be increased as well or R&D will continue to be shortchanged and thus hamstringing Army transformation. If this is not rectified, the Army will be unable to research, experiment, develop and test the requisite technologies and systems for meeting the CSA's vision of a lethal, survivable, deployable, agile, flexible and responsive Objective Force, and to protect

future readiness. We therefore urge the government to sustain FY 2001 R&D funding levels throughout the FYDP and, together with the Army, focus this investment on:

1. Restoring R&D program stability. Stop stretching out and delaying the demonstration and development of capabilities critical to realizing the Army and Joint vision.
2. Restoring project manager funding for development risk reduction to meet cost, schedule and performance. Risk reduction funding was often a casualty of the modernization death spiral.
3. Leveraging non-Army DoD, defense industry, commercial and university S&T to meet the needs of the Army and Joint visions as articulated in the DoD and Army S&T plans.
4. Building on the emerging Army/DARPA land warfare advanced technology collaboration. DARPA excels at high risk/payoff research and technology. The Army excels at technology demonstration, transition and warfighting innovation. It is a win-win relationship.

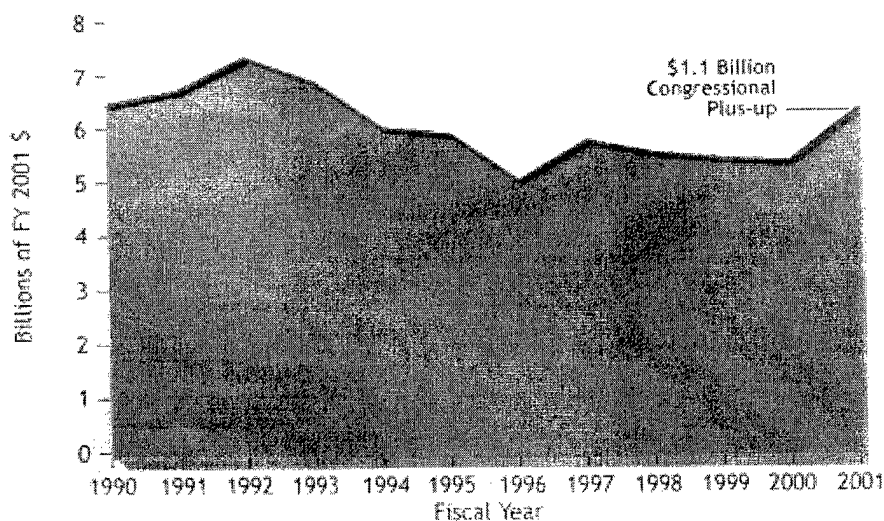

Figure 5
Army RDT&E

Source: Department of Defense

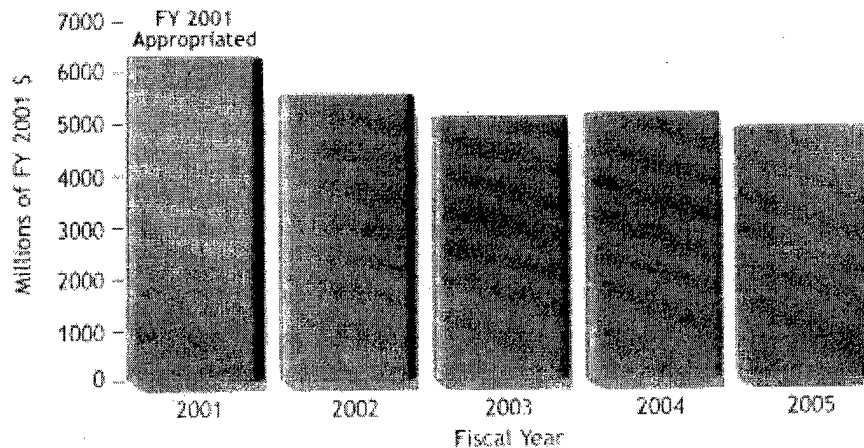



Figure 6
*Army R&D in the
Future Years Defense Plan*

Source: Department of Defense

5. Taking an experimental, "spiral" development approach to requirements and concept development for the Objective Force, consistent with Joint Vision 2020. In addition, develop models and other tools to simulate and emulate systems-of-systems warfare and the capabilities, benefits and vulnerabilities associated with speed and knowledge.
6. Providing Army Laboratory Directors and Program Executive Officers with sufficient funds to invest in technologies and products—especially commercial products—that will provide an order of magnitude return on investment by reducing system operation and support costs. This will arrest the rising operations and support (O&S) costs of our aging legacy force and help reduce the logistic footprint (and thus the O&S costs) of the Objective Force, thereby reversing the current migration of modernization funding to pay for rising O&S costs.
7. Expanding cooperative research with academia and industry, particularly the increasingly important commercial sectors of information technology, electronics, computers, visualization, robotics and biotechnology. Sound models for such linkages already exist, including the Institute for Creative Technologies, the National Rotorcraft Technology Center, the National Automotive Center, and the ARL Federated Laboratories.
8. Expanding the Army's use of university and contractor researchers in an open laboratory environment while retaining the ability to hire world class government scientists. This will help combat the compensation disadvantage the Army labs suffer vis-a-vis the commercial sector and, in the process, help provide for a more agile, competitive work force.

**This great nation has equipped and trained today's
soldiers with the best technology and weapons in the world,
resulting in an Army possessing superior lethality and survivability.
Tomorrow's Army deserves no less.**



Reproduction of this report, in whole or in part, is authorized
with appropriate acknowledgement of the source.

Institute of Land Warfare
ASSOCIATION OF THE UNITED STATES ARMY
2425 Wilson Boulevard, Arlington, Virginia 22201-3385
800-336-4570
www.ausa.org

INTERNET DOCUMENT INFORMATION FORM

A. Report Title: The Research and Development Enabling Transformation.

B. DATE Report downloaded From the Internet: October 19, 2000

C. Report's Point of Contact: (Name, Organization, Address, Office Symbol, & Ph #): AUSA's, 2425 Wilson Blvd, Arlington, VA 22201

D. Currently Applicable Classification Level: Unclassified

E. Distribution Statement A: Approved for Public Release

**F. The foregoing information was compiled and provided by:
DTIC-OCA Initials: __LL__ Preparation Date October 19, 2000**

The foregoing information should exactly correspond to the Title, Report Number, and the Date on the accompanying report document. If there are mismatches, or other questions, contact the above OCA Representative for resolution.