

AD _____

Award Number: DAMD17-94-J-4288

TITLE: Vasopressin Gene-Related Products in the Management of Breast Cancer

PRINCIPAL INVESTIGATOR: William G. North, Ph.D.

CONTRACTING ORGANIZATION: Dartmouth College
Hanover, New Hampshire 03755-1404

REPORT DATE: October 1999

TYPE OF REPORT: Final

PREPARED FOR: U.S. Army Medical Research and Materiel Command
Fort Detrick, Maryland 21702-5012

DISTRIBUTION STATEMENT: Approved for Public release;
distribution unlimited

The views, opinions and/or findings contained in this report are those of the author(s) and should not be construed as an official Department of the Army position, policy or decision unless so designated by other documentation.

DTIC QUALITY INSPECTED 4

20001018 045

REPORT DOCUMENTATION PAGE

Form Approved
OMB No. 074-0188

Public reporting burden for this collection of information is estimated to average 1 hour per response, including the time for reviewing instructions, searching existing data sources, gathering and maintaining the data needed, and completing and reviewing this collection of information. Send comments regarding this burden estimate or any other aspect of this collection of information, including suggestions for reducing this burden to Washington Headquarters Services, Directorate for Information Operations and Reports, 1215 Jefferson Davis Highway, Suite 1204, Arlington, VA 22202-4302, and to the Office of Management and Budget, Paperwork Reduction Project (0704-0188), Washington, DC 20503

1. AGENCY USE ONLY (Leave blank)	2. REPORT DATE October 1999	3. REPORT TYPE AND DATES COVERED Final (1-Oct-94 - 30-Sep-99)	
4. TITLE AND SUBTITLE Vasopressin Gene-Related Products in the Management of Breast Cancer		5. FUNDING NUMBERS DAMD17-94-J-4288	
6. AUTHOR(S) William G. North, Ph.D.		8. PERFORMING ORGANIZATION REPORT NUMBER	
7. PERFORMING ORGANIZATION NAME(S) AND ADDRESS(ES) Dartmouth College Hanover, New Hampshire 03755-1404 E-MAIL: William.G.North@dartmouth.edu			
9. SPONSORING / MONITORING AGENCY NAME(S) AND ADDRESS(ES) U.S. Army Medical Research and Materiel Command Fort Detrick, Maryland 21702-5012		10. SPONSORING / MONITORING AGENCY REPORT NUMBER	
11. SUPPLEMENTARY NOTES			
12a. DISTRIBUTION / AVAILABILITY STATEMENT Approved for public release; distribution unlimited			12b. DISTRIBUTION CODE
13. ABSTRACT (Maximum 200 Words) The goal of this project has been to improve the detection and treatment of breast cancer by characterizing vasopressin gene expression by this disease and determining the nature and role of products generated through this expression. We have demonstrated that the vasopressin gene is expressed by seemingly all breast cancers and all ductal carcinoma in situ (DCIS), and this information coupled with an absence of vasopressin gene-related products from fibrocystic disease potentially provides us with a new screening test for distinguishing both breast cancer and DCIS from atypical intraductal hyperplasia. A capability to make this distinction will in many cases prevent the need for unnecessary surgery. Studies on cell trafficking in breast cancer of vasopressin gene-products have shown that almost all protein processing is outside of conventional secretory vesicles, the major processing enzymes (CPE, PC1/3, PC2, and PAM) are expressed as normal and probably functional proteins, and components of glycopeptide-related cell surface antigen (GRSA) comprise both 20 KDa and 40 KDa vasopressin-related proteins that we have now partially-characterized. Meoities on both of these proteins are potential targets for immunotherapy. Partial structures for these proteins have been determined, and monoclonal Abs against tumor-specific surface structures have now been generated. Substantial evidence has been gathered supporting the mitogenic actions of vasopressin on breast cancer, and a structure obtained by us for the complete open reading frame of a new putative hVACM vasopressin receptor expressed by breast cancer cells. Breast cancer expression of all other vasopressin receptor subtypes (V1a, V1b, V2, and an abnormal V2) has been confirmed. We have now achieved the complete sequencing of the open reading frames for V1a, V1b, and V2 receptors of MCF-7 and ZR-75 breast cancer cells, and discovered that all normal structures are present. In addition, these breast cancer cells generate an abnormal V2 receptor from the incomplete splicing of transcribed mRNA. The presence of all of the vasopressin receptors in these breast cancer cells has been confirmed by Western analysis. Recent studies have centered on establishing methods for generating and isolating DTPA-labeled Fab fragments of our monoclonal antibodies, and it is believed these will be effective for targeting breast cancer cells in vivo. We intend to move our many findings over to patient care as soon as funding for such translational research becomes available.			
14. SUBJECT TERMS Vasopressin, Early Detection, Surface Markers, Gene-Expression, Tumor Targeting, Breast Carcinoma, Breast Cancer			15. NUMBER OF PAGES 202
			16. PRICE CODE
17. SECURITY CLASSIFICATION OF REPORT Unclassified	18. SECURITY CLASSIFICATION OF THIS PAGE Unclassified	19. SECURITY CLASSIFICATION OF ABSTRACT Unclassified	20. LIMITATION OF ABSTRACT Unlimited

FOREWORD

Opinions, interpretations, conclusions and recommendations are those of the author and are not necessarily endorsed by the U.S. Army.

MP Where copyrighted material is quoted, permission has been obtained to use such material.

 Where material from documents designated for limited distribution is quoted, permission has been obtained to use the material.

 Citations of commercial organizations and trade names in this report do not constitute an official Department of Army endorsement or approval of the products or services of these organizations.

MP X In conducting research using animals, the investigator(s) adhered to the "Guide for the Care and Use of Laboratory Animals," prepared by the Committee on Care and use of Laboratory Animals of the Institute of Laboratory Resources, national Research Council (NIH Publication No. 86-23, Revised 1985).

N/A For the protection of human subjects, the investigator(s) adhered to policies of applicable Federal Law 45 CFR 46.

MP X In conducting research utilizing recombinant DNA technology, the investigator(s) adhered to current guidelines promulgated by the National Institutes of Health.

MP X In the conduct of research utilizing recombinant DNA, the investigator(s) adhered to the NIH Guidelines for Research Involving Recombinant DNA Molecules.

MP X In the conduct of research involving hazardous organisms, the investigator(s) adhered to the CDC-NIH Guide for Biosafety in Microbiological and Biomedical Laboratories.



PI - Signature 10/29/99
Date

TABLE OF CONTENTS

<u>SECTION</u>	<u>PAGE NUMBER</u>
(1) FRONT COVER	1
(2) REPORT DOCUMENTATION PAGE	2
(3) FOREWORD	3
(4) TABLE OF CONTENTS	4
(5) INTRODUCTION	5-6
(6) BODY	6-16
(7) KEY RESEARCH ACCOMPLISHMENTS	17
(8) REPORTABLE OUTCOMES	18-20
(9) CONCLUSION	21-22
(10) REFERENCES	22-24
(11) FINAL REPORT: BIBLIOGRAPHY AND PERSONNEL	25-27
(12) APPENDIX	28-

(5) INTRODUCTION

The overall objective of this project was to improve the detection and treatment of breast cancer by evaluating vasopressin gene-related products as tumor marker substances in hyperplastic breast disease, by characterizing the nature and regulation of the vasopressin gene and its products in breast cancer, and by determining the potential usefulness of vasopressin gene-related products on tumor membranes as targets for immunotherapy. It sought to test the hypothesis that all breast tumors produce vasopressin as an autocrine growth factor, in situ, and that this property can be effectively utilized not only to elucidate the pathobiology of this cancer, but also to identify precancerous tissue and develop more successful treatments.

In hypothalamic neurons, vasopressin gene expression leads to the formation of a 750 bp mRNA and the subsequent generation of a 20 KDa precursor that undergoes intragranular enzymatic processing to form vasopressin (VP), vasopressin-associated human neurophysin (VP-HNP), and vasopressin-associated glycopeptide (VAG). All three of these products are released into the circulation by exocytosis. **None** of these products become components of the plasma membrane of neurons.

We have shown that the **vasopressin gene** of chromosome 20 is **expressed by apparently all breast tumors, but not by normal breast tissue** (*North et al., 1995). This indicates that in the mammary gland, the expression of the vasopressin gene is a feature unique to tumor cells, a feature common to all hyperplastic tissues, or a feature shared only by tumor cells and their progenitors. The first and third of these possibilities raised the potential use of this expression as a marker of carcinogenesis, and/or forecaster of imminent disease. We therefore conducted a survey of the incidence of vasopressin gene expression in fibrocystic disease, and this work has been accepted, with modification, for publication in *Endocrine Pathology*. No evidence for gene expression could be found for all cases of fibrocystic disease examined, including atypical intraductal hyperplasia. In our study, three individuals with benign breast disease went on to develop breast cancer. Taken together, these findings indicate vasopressin gene expression is not a marker of cellular proliferation in the breast, nor a marker of cancer progenitor cells in benign breast disease (*Fay et al., 1997). This leads us to the conclusion that vasopressin gene expression in the breast is likely to be solely associated with the process of carcinogenesis. Therefore, it would seem **the vasopressin gene is an oncogenic marker of breast cancer. We have recently confirmed this through studying vasopressin gene expression in cases of carcinoma in situ (DCIS)**. All of 12 cases of DCIS studied showed a clear expression of the vasopressin gene, and we are currently investigating the possibility of using this finding to develop a diagnostic test for distinguishing atypical hyperplasia from DCIS (see Body of this report).

Expression of the vasopressin gene in breast cancer leads to the formation of unique gene-related products, some of which become associated with the plasma membrane of tumor cells. Because these membrane-associated products react with antibodies raised against human vasopressin-associated glycopeptide (VAG), we have referred to them as **GRSA (Glycopeptide Related cell Surface Antigen)**. Because they are located at the cell membrane of the tumor cells, we have demonstrated they can be targeted, *in vitro*, with antibodies to VAG. This raises the possibility they can be utilized for targeting tumors in patients through immunotherapy. We have excellent indirect evidence that strengthens this possibility. Breast cancer uniquely shares the feature of membrane expression of vasopressin gene-related products with small-cell carcinoma of the lung (SCCL), and we have shown we can successfully target these products in SCCL patients using radioiodinated and Indium-labeled antibodies (*North et. al, 1989, *North and Yu, 1993).

What is the nature of GRSA? The VP mRNA and protein products that arise in breast cancer through expression of the vasopressin gene appear to be both structurally normal and abnormal (see Body of this report). We had anticipated this possibility because we (and others) have earlier shown that abnormal and normal forms co-exist in SCCL (*North et. al, 1983; Rosenbaum et. al, 1990; *North and Yu, 1993). There appear to be two VPmRNAs in both breast cancer and SCCL. One of these is sequentially almost identical to that in human hypothalamic neurons, while the other is extended by 600 base pairs at the 5' end of the reading frame. The VPmRNAs of both types of tumors give rise to proteins of 40 KDa and 20 KDa as prominent forms, although the proteins of breast cancer appear to show some structural differences to those of SCCL (*North et al., 1995). The 20 KDa form of SCCL is almost identical to the

provasopressin of hypothalamic neurons. Both 40 KDa and 20 KDa proteins of SCCL become incorporated into the cell membrane as cell-surface antigens. Studies to fully characterize the two VPmRNAs of breast cancer are still in being performed. **We have recently shown that both 40 KDa and 20 KDa proteins of this tumor type represent GRSA at tumor cell surfaces** (see Body of this report).

In normal hypothalamic neurons, 20 KDa provasopressin is processed by proteolysis that is thought to involve at least four enzymes. That such proteolysis also occurs in breast cancer is evidenced by our preliminary findings that most patients with breast cancer have inappropriately high plasma levels of vasopressin, and elevated levels of VAG (**unpublished data**). Breast cancer can therefore be classified as neuroendocrine in nature. Because of this, we performed studies that demonstrated the presence of the key processing enzymes, carboxypeptidase E, and prohormone convertases PC2 or PC1/3, and PAM, in the two breast cancer cell lines MCF7 and ZR-75-1.

Why is vasopressin produced by breast cancer? One answer to this question is that vasopressin serves as an autocrine growth factor for these tumors. Vasopressin is already known to act as a growth factor/growth modulating agent in SCCL lines where it promotes calcium mobilization and clonal growth (Hong and Moody, 1991; Sethi and Rozengurt, 1991, Cassoni et al., 1994,1996,1997). Over the last three years we reported that vasopressin can promote calcium mobilization in two breast cancer cell lines, ZR-75-1 and T47D, and can dramatically influence the cytoskeleton of ZR-75-1. These findings are supported by previous studies on a dimethylbenzathrene-induced rat mammary tumor (Monaco et al., 1978; Monaco et al., 1980; Guilon et al., 1986; Kirk et al., 1986; Woods and Monaco, 1988), human MCF7 breast cancer cells (Taylor et al., 1990), and on another breast cancer cell line (Bunn et al., 1992). Choi et al. (1994) were also able to show that vasopressin promotes growth of mammary tumors in transgenic mice. These actions of vasopressin have prompted us to investigate the nature of vasopressin receptors on breast cancer cells. Four vasopressin receptors have been identified in other cells and have been cloned (Birnbauer et al., 1992; Hirasawa et al., 1994; Sugimoto et al., 1994; Thibonnier et al., 1994; Burnatowska-Hledin et al., 1995, *Fay et al., 1994,1996; *North et al., 1997a,1997b). These are known as vasopressin V_{1a}, V_{1b}, and V₂, receptors plus vasopressin-activated calcium-mobilizing receptor (VACM1). Although an investigation of vasopressin receptors and the growth promotional activities of vasopressin may seem to fall outside of intentions enunciated in the original proposal, we believe they nevertheless address the body of the hypothesis originally advanced in the proposal and fall within the goals of Technical objectives 2 and 3. It is believed that such an investigation could not only explain the seemingly universal expression of the vasopressin gene in breast tumors, but also lead to an additional number of effective therapies. **Therefore, over the course of this year we have now completed the sequencing of the entire open reading frames (ORFs) of vasopressin V1a, V1b, and V2 receptor mRNAs of the breast cancer cell line MCF-7 and have prepared a manuscript for submission to the journal, Molecular Endocrinology** (see Appendix).

(6) BODY

Technical Objective 1: Vasopressin gene-expression in breast hyperplasia as a predictor of cancer (Task 1 in Statement of Work).Breast Cancer/Carcinoma in situ/hyperplasia.

This objective has been satisfied. We also report on our discovery that the vasopressin gene is expressed by all carcinoma in situ examined and the implications of this finding. **These recent findings have not yet been published.** Also, for the sake of clarity, we include below a summary of all earlier reported findings. Our findings taken together show that **vasopressin gene expression is a marker of oncogenic transformation in breast tissues.**

Breast Cancer: We performed immunohistochemistry on 19 breast cancers representing a variety of tumor subtypes using antibodies directed against different moieties of the vasopressin precursor structure as indicated in Figure 1, below. These comprised rabbit polyclonal antibodies that recognize arginine vasopressin (anti-VP), the tripeptide bridge region of the precursor (anti-ProVP), and the carboxyl region of vasopressin-associated human glycopeptide (anti-VAG); and mouse monoclonal antibodies that

recognize an amino terminal portion of vasopressin-associated human neurophysin (anti-VP-HNP). Western Blot analysis was performed on protein extracts from an additional 12 breast tumors.

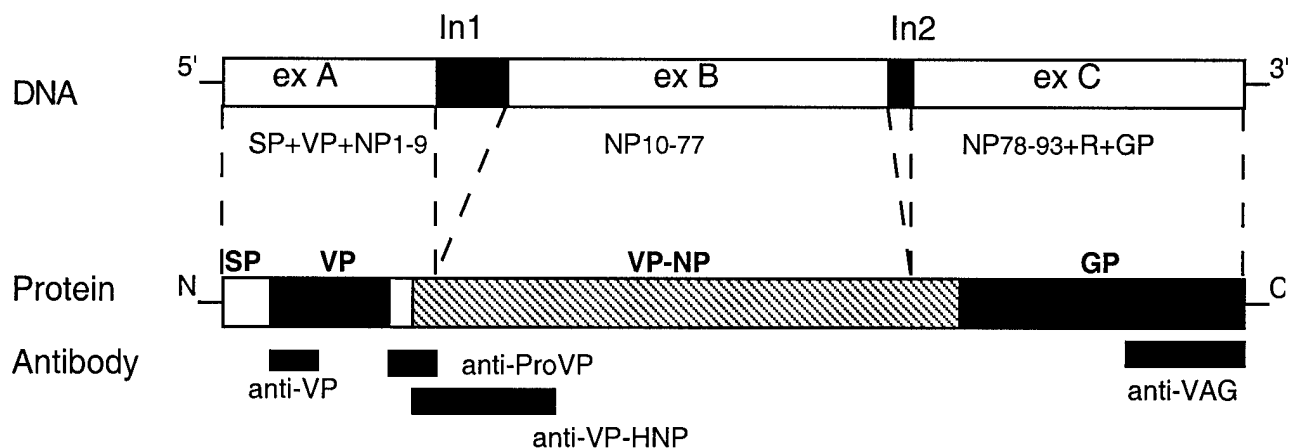

Figure 1. Illustration depicting the structures of the vasopressin gene and protein precursor. Regions of the precursor are blocked out against which Abs, used in immunohistochemistry of breast cancer, are directed.

As shown in Table 1, while VP-related proteins were not detected in normal breast tissues, immunohistochemistry revealed the presence of VP and VAG in all neoplastic cells of all tumor tissues examined. ProVP was evident in 11 of 14 tumors while VP-HNP was evident in only one of 19 tumors examined.

Table 1. Presence of vasopressin gene related products in human breast cancer

cancer subtype	VP gene related antigens*			
	VP	ProVP	VP-HNP	VAG
Infiltrating ductal	na	na	-	+
Infiltrating ductal	+	+	-	+
Infiltrating ductal	+	+	-	+
Infiltrating ductal	+	+	+	+
Infiltrating ductal	+	+	-	+
Infiltrating ductal	+	-	-	+
Infiltrating ductal	+	+	-	+
Infiltrating ductal	+	na	-	+
Infiltrating ductal	+	+	-	+
Infiltrating ductal	+	+	-	+
Infiltrating ductal	+	-	-	+
Infiltrating ductal	+	-	-	+
Colloid	+	+	-	+
Colloid	+	na	-	+
Colloid	+	+	-	+
Colloid	+	+	-	+
Infiltrating tubular	+	na	-	+
Infiltrating tubular	+	+	-	+
Infiltrating lobular	+	na	-	+
Total positive	18/18	11/14	1/19	19/19

*Positive (+) or negative (-) immunoreactivity using antibody preparations and the ABC procedure. na = not attempted.

However, Western blot analysis for all 12 fresh-frozen tumor samples showed the presence of two proteins of 42 KDa and 20 KDa, that were both immunoreactive with, not only antibodies against VP and VAG, but also those against VP-HNP (anti-ProVP were not used). The vasopressin precursor of hypothalamic tissues is 20 KDa in size. These findings provided evidence that the vasopressin gene is expressed as a selective feature of all breast cancers. This expression apparently gives rise to an abnormally large vasopressin-related protein, and one protein of normal size with possible modifications in the neurophysin region making it less immunoreactive with anti-VP-HNP. Both proteins represent potential markers for tumor detection and potential targets for immunotherapy.

Fibrocystic Disease: In order to examine if vasopressin gene expression was a possible predictor of disease, we performed a survey of the incidence of vasopressin gene expression in fibrocystic disease, and this work has now been accepted, pending revision, for publication in *Endocrine Pathology*. In this study, we used immunohistochemistry and antibodies against vasopressin (anti-VP) and vasopressin-associated glycopeptide (anti-VAG) to examine formalin-fixed biopsy specimens taken from 17 patients, with various forms of benign breast disease, who were seen at Dartmouth Hitchcock Medical Center between 1975 and 1984. These specimens were selected without any knowledge of follow-up, and included 4 cases of atypical ductal hyperplasia, 6 cases of fibrocystic disease with intraductal hyperplasia, 2 cases of fibrocystic disease with papilloma, 1 case of fibrocystic disease with bilateral mammary hyperplasia, and 4 cases of typical fibrocystic disease. Diagnosis from pathology reports was confirmed by examining hematoxylin- and eosin-stained sections. The results of these studies are illustrated in Table 2, and demonstrate that in all cases of benign breast disease examined there was negative staining for both vasopressin and vasopressin-associated glycopeptide. They indicate that the vasopressin gene is not expressed in benign breast disease, and this is in dramatic contrast to what was found for human breast carcinoma using these same antibodies (Table 1). At the completion of the study, it was discovered that three of the individuals with benign breast disease went on to develop breast carcinoma. Although preliminary, these data taken together indicate that (i) expression of vasopressin gene related products is not a marker of cellular proliferation in the breast, (ii) expression of vasopressin gene-related products is associated with the process of carcinogenesis, and (iii) expression of vasopressin gene-related products is not a marker of precancerous cells in benign breast disease.

Table 2. Absence of vasopressin gene-related products from benign breast fibrocystic conditions

Subtype	VP gene-related antigens*	
	VP	VAG
Fibrocystic Disease	-	-
Fibrocystic Disease	-	-
Fibrocystic Disease	-	-
Fibrocystic Disease	-	-
Fibrocystic Disease with Intraductal Hyperplasia	-	-
Fibrocystic Disease with Intraductal Hyperplasia	-	-
Fibrocystic Disease with Intraductal Hyperplasia	-	-
Fibrocystic Disease with Intraductal Hyperplasia	-	-
Fibrocystic Disease with Intraductal Hyperplasia	-	-
Fibrocystic Disease with Intraductal Hyperplasia	-	-
Atypical Intraductal Hyperplasia	-	-
Atypical Intraductal Hyperplasia	-	-
Atypical Intraductal Hyperplasia	-	-
Fibrocystic Disease with Intraductal Papilloma	-	-
Fibrocystic Disease with Intraductal Papilloma	-	-
Fibrocystic Disease with Bilateral Mammary Hyperplasia	-	-
Total Positive	0/16	0/16

*Positive (+) or negative (-) immunoreactivity using ABC immunohistochemistry

Carcinoma in situ: We used immunohistochemistry with anti-VAG antibodies to examine vasopressin gene expression in pre-invasive carcinoma. Blocked out biopsy samples of twelve cases of carcinoma in situ, six of which have been clearly identified as being of the **comedo** variety with abnormal cells and extensive necrotic areas, were investigated. All twelve cases (Table 3) showed positive staining with anti-VAG demonstrating for this small sampling that vasopressin gene expression is commonly associated with breast carcinoma in situ (Figure 2). Of the DCIS samples, the comedo variety gave the most intense staining.

Table 3. Presence of vasopressin gene-related products in carcinoma in situ

Subtype	<u>VP gene-related antigen*</u> VAG
Carcinoma in situ, non-comedo	+
"	+
"	+
"	+
"	+
"	+
Carcinoma in situ, comedo	+
"	+
"	+
"	+
"	+
"	+
Total Positive	12/12

*Positive (+) or negative (-) immunoreactivity using ABC immunohistochemistry

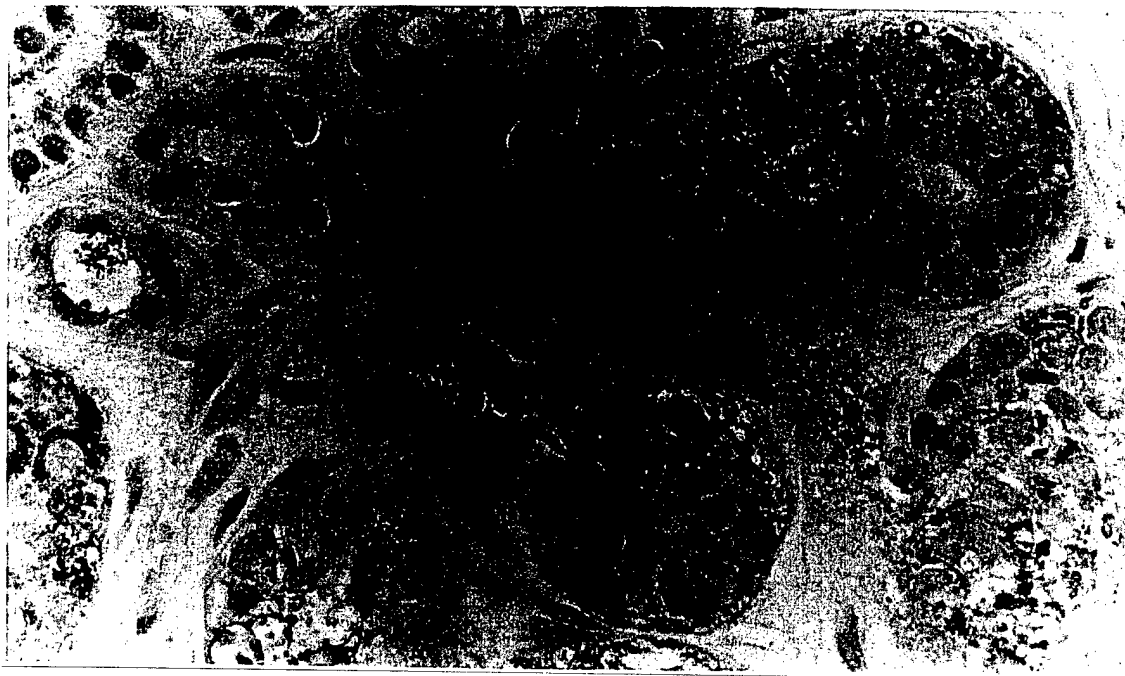

Figure 2. Carcinoma in situ stained using the ABC immunohistochemical method with Abs against VAG

The above results indicate that ABC immunohistochemistry with our antibodies to VAG can clearly distinguish atypical ductal hyperplasia from carcinoma in situ, a distinction currently difficult to make using other available methods. This distinction is important because a diagnosis of atypical hyperplasia has

no follow-up, while carcinoma in situ is generally followed-up with ablative surgery. We are therefore intending to further test this finding by embarking on a screening study that will compare evaluation by histochemical analysis alone with an evaluation that uses both histochemistry and VAG immunohistochemistry.

Technical Objective 2: Characterization of vasopressin gene expression by breast cancer cells (Tasks 2 and 3 in Statement of Work).

The data discussed in this section are largely unpublished.

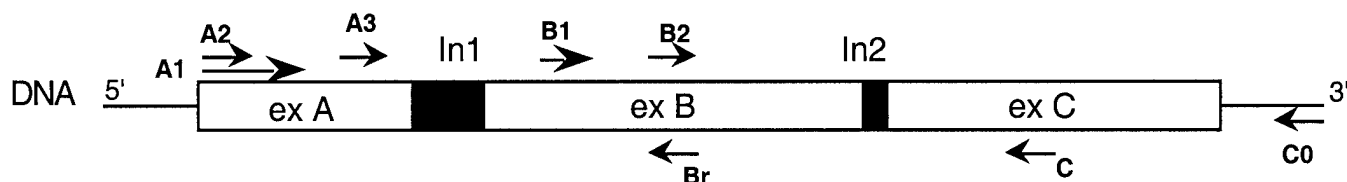

Structure of Human vasopressin gene and locations of some designed PCR primers

Figure 3

We have established for breast cancer cells that there is abnormal, in addition to normal, production of vasopressin. Abnormal protein forms constituting GRSA might to be generated from one normal and one abnormal gene. RT-PCR, cloning, and sequencing studies on messages from the vasopressin gene of MCF7, T47D, and ZR-75-1 cells have now shown that there appear to be at least two VPmRNAs expressed in breast cancer, one from a 'normal' gene and the product of normal splicing, the second either from a 'normal' gene and the product of alternate splicing or from an abnormal gene having insertions in exon A. The ten primers used in studies are illustrated in the figure above and described in the following table .:

Table 4. Forward and reverse primers designed for RT-PCR amplification of human vasopressin gene fragments from human breast cancer cells

Forward primer	Length	Nucleotides	Exon	Sequence
A1	21	269-289	1	5'-cttctcctccgctgactt-3'
A2	18	269-286	1	5'-cttctcctccgctgcta-3'
A3	21	321-341	1	5'-atgtccgacctggagctgaga-3'
IN	21	1504-1524	intron 1	5'-gtcatccaagaaaccaaggtg-3'
B1	25	1751-1775	2	5'-tgcttcgggcccagcatctgctgcg-3'
B2	22	1830-1851	2	5'-tgccaggaggagaactacctgc-3'
Reverse primer				
INR	20	1517-1536	intron 1	5'-agatctgctcggcaccttgg-3'
Br	22	1830-1851	2	5'-gcaggtagtctcctctggga-3'
C	22	2152-2173	3	5'-agcaacgccacgcagctggacg-3'
C0	25	2231-2255	3	5'-taggcgtcgggctggggcgggctcga-3'

Normal-sized VPmRNA fragments of 313 bp using **A3C** were obtained from three cell lines. These have been partially sequenced and shown to have a sequence very similar to the VPmRNA found in hypothalamic neurons. We also isolated, and successfully reamplified (but have not yet sequenced) an RT-PCR product(s), from all three cell lines using the specific primers **A1** and **C**, that is 600 bases larger than that predicted from the structure of VPmRNA. Such a structure could represent a VPmRNA that have retained a 600 base portion of intron 1 through alternative splicing (the entire intron 1 segment contains

1373 bases). If the 5' sequence of the product confirms it translates a protein with the N-terminus of provasopressin, it will offer one explanation for the 40,000 dalton species of breast cancer because an extra 600 bases represents an additional 200 amino acid residues. Adding 200 amino acid residues to the 20,000 dalton provasopressin would give a protein of 40,000 daltons. Since antibodies recognize the exon B (at least in Western analyses) and exon C regions of the protein (North et al., 1995) the intronic insertion would not apparently cause a reading frame shift. The structure of the enlarged form will now be checked through reamplification using both **A2** and **C** primers, and **A3** and **C** primers. If the additional 600 bases in **A1C** are from intron 1, we expect in all cases, reamplified products that are approximately 600 bases larger than predicted from normal VPmRNA. However, if products of normal size are produced this will suggest the enlarged form represents an abnormal vasopressin gene having a 600 base insertion in the exon A region. This insertion would be between bases corresponding to the vasopressin and neurophysin structures. Structures **A2** and **A3** are only separated by 35 bases in normal VPmRNA. While a definitive answer regarding the enlarged form will be best provided through cloning and DNA sequencing, the planned exercise will enable us to eliminate the possibility of alternative co-existing forms. Use of primers **B1**, **B2**, **C** and **Co** will likewise enable us to discover if forms extended in the exon B and/or exon C region exist in breast cancer cells (as found by us in SCCL), while use of the forward **IN** and reverse **INR** primers will allow us, when used with **B** and **A** primers, to obtain shortened RT-PCR products for sequencing if regions of intron 1 are indeed included in the abnormal VPmRNA structure. All of these primers have already been used somewhat successfully by us in sequencing VPmRNA forms from SCCL (unpublished). However, two abnormal VPmRNA structures found by us for SCCL have recently been entered into the GENEbank with accession numbers

We have also made efforts to perform Edman sequencing on purified samples of GRSA proteins. We have decided to concentrate our studies on protein obtained from the cell line MCF-7 and used these cultured cells as the protein sources. Purification employed pH-salt separations, molecular sieve chromatography, and affinity chromatography on columns of Antivasopressin-Sepharose. Our antivasopressin monoclonal antibody, DEN1, was used to generate such an affinity resin. Protein mixes from affinity chromatography were S-alkylated and then separated using SDS-PAGE. We then intended performing solid-phase sequencing. However, both 20 KDa and 40 KDa proteins appeared to have blocked N-terminal residues, so, as yet, no sequence information could be found for GRSA proteins using this approach.

PCR studies on DNA preparations from breast cancer cell lines have also been conducted using a mixture of specific primers for the vasopressin gene and oxytocin genes. This is because a published study (Morris et al., 1995) has indicated that some hypothalamic neurons in rats can express protein products that are a composite of provasopressin and pro-oxytocin through a cross-over between the vasopressin and oxytocin genes on chromosome 20. **We have established that there is no evident cross-over between the vasopressin and oxytocin genes in breast cancer.**

Studies were also performed that examined sub-cellular trafficking in ZR-75-1 breast cancer cells (unpublished data).

Sucrose-gradient sub-fractionation of these cells (10^8 cells/batch) was carried out and an evaluation conducted by Western analysis and by RIA (VP, VP-HNP, VAG). This evaluation revealed that approximately 80% of **both** the 20 KDa and 40 KDa proteins are located in the plasma membrane. Of the remaining 20%, most (90%) is found outside secretory granules, and approximately 10% is within these granules. The procedures employed were found by us to preserve granules from hypothalamic neurons with >90% of vasopressin gene-related products located in the granular fraction. Hence, either the granules of breast cancer are more susceptible to rupture, or only a small percentage (< 2%) of translated protein is potentially processed to active hormone within these granules and then secreted. This implies that packaging is limited and most protein in breast cancer cells is destined for agranular targeting to the plasma membrane. Both 20 KDa and 40 KDa proteins were found in the granular fraction of cells. This indicates that the 40 KDa product shows a capacity similar to the 20 KDa product to be packaged in the Golgi apparatus. This study indicates that the limited processing of 20 KDa and 40 KDa vasopressin gene-related proteins in breast cancer is largely due to limited packaging of translated material, rather than to an absence of processing enzymes. An almost identical trafficking pattern was found for SCCL cells in culture and reported on last year.

The breast cancer cell lines MCF7 and ZR-75-1 were examined for the expression of mRNAs for the processing enzymes carboxypeptidase E (CPE), prohormone convertases PC2 and PC1 (or PC3), and PAM, using RT-PCR, cloning, and sequencing. **These studies have been submitted for publication.** The primer pairs used in these studies are depicted in figure below.

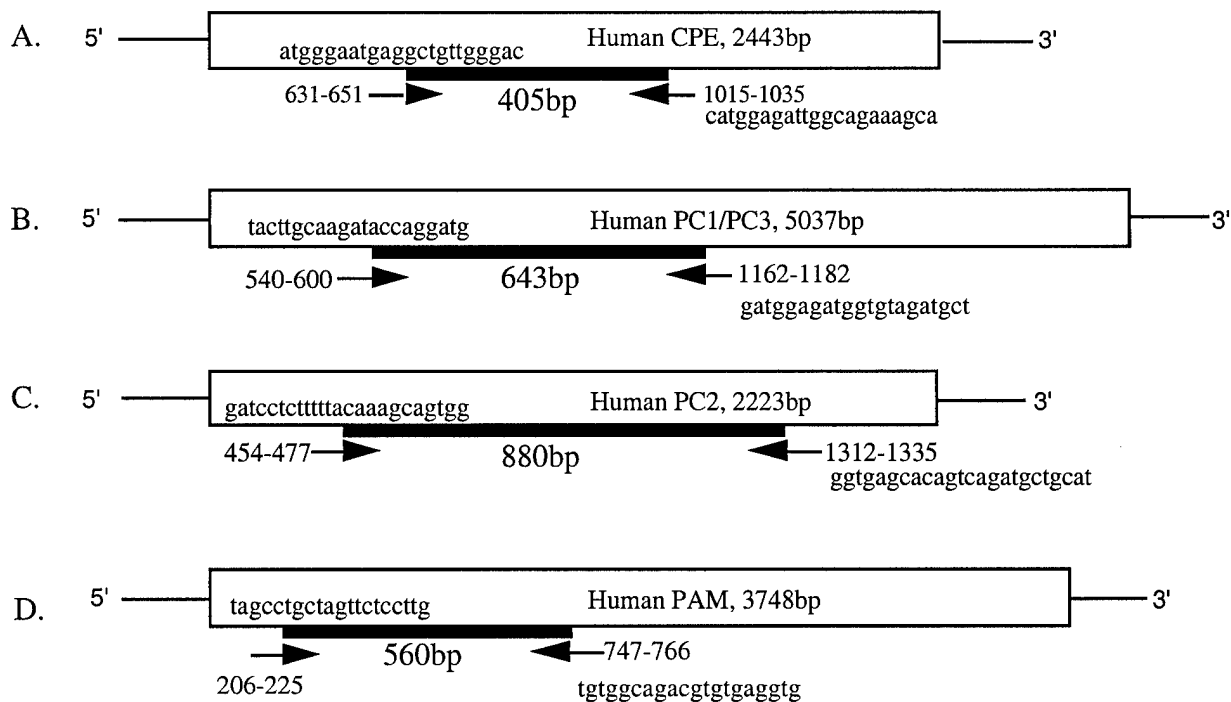

Primers designed for amplification cDNA fragments of carboxypeptidase E(CPE)(A), prohormone convertases(PC)1/3(B), PC2(C) and peptidylglycine alpha-amidating monooxygenase(PAM)(D) from breast cancer cell line MCF-7.

RT-PCR studies on CPE provided amplified products of the size predicted from previously published studies on anterior pituitary cells using polyA⁺RNA from both cell lines. These products for MCF-7 were reamplified, cloned and sequenced to provide structures identical to those published for this enzyme. In RT-PCR studies on PC2 we have so far only been able to amplify a product using polyA⁺RNA from MCF7. We then investigated if mRNA for PC1/3 was expressed in MCF7 and ZR-75-1. However, RT-PCR failed to show that this mRNA was expressed in either cell line. **We subsequently performed RT-PCR for the enzyme employing the more sensitive 'platinum' Taq polymerase and were then able to demonstrate the enzyme PC1/3 is expressed by MCF-7 cells. The expression of all these enzymes by breast cancer have now been confirmed using available antibodies against CPE, PC1, PC2, and PAM in Western analysis. These antibodies were provided to us through the generosity of Dr. Lloyd Fricker of Albert Einstein Medical School, and of Drs. Betty Eiper and Richard Mains of Johns Hopkins.** Our results therefore show that at least **four** of the enzymes necessary for processing provasopressin to active hormone, neurophysin, and glycopeptide, are present in some breast cancer cell lines. This finding confirms conclusions expressed above that a failure of breast cancer cells to process vasopressin precursor proteins in the same manner or extent as central neurons is probably due to differences in sub-cellular packaging rather than to an absence of any of the enzymes necessary for processing.

**Technical Objectives 3: Identification of factors regulating the production of GRSA by breast cancer; and
4: Determination of the binding properties for antibodies of GRSA and other vasopressin gene-products at tumor cell surfaces (Tasks 4 and 5 of Statement of Work).**

We decided during this last year of no-cost extended funding not to pursue studies designed to examine vasopressin gene regulation in breast cancer cells that would satisfy technical objective 3. This is because we are of the opinion our findings for small-cell carcinoma probably also hold for breast cancer, and these findings indicate that at least 1Kb of normal promoter region for the vasopressin gene is upstream of this gene in cancer cells (North, 1999). It then follows all of the transcriptional elements known to regulate expression by hypothalamic neurons are present and capable of a similar regulation within breast cancer cells in vitro. However, we have also shown (North, 1991) that vasopressin production by cancer cells in patients is seemingly autonomous, or at least largely unregulated. This suggests findings on regulation from cell culture would not have direct relevance to tumors in patients. We are currently investigating the reasons for in vitro/in vivo differences with SCCL cell lines as part of another project (North, 1999). During this final year of funding we also decided not to examine binding to tumor cell surfaces with our current polyclonal antibodies against vasopressin gene-products (Task 5, Statement of Work), but felt our time and effort would be better served by generating monoclonal antibodies to vasopressin-associated human glycopeptide (anti-VAGs) and evaluating these antibodies for possible tumor targeting. We are happy to report we were successful in generating four such antibodies (three IgG1 and one IgG2b). All four antibodies have been shown to identify both 20 Kda and 40 Kda GRSA proteins of breast cancer in Western analysis, and they will now be tested for binding to the surface of viable tumor cells. We also devoted considerable effort into developing and standardizing methods for converting our monoclonal antibodies into Fab fragments, attaching DTPA chelating groups, and isolating products in pure form. Methods include affinity purification of the antibodies, ficin cleavage of the reduced protein, Protein A affinity isolation of Fab product, reaction of the product with DTPA anhydride, and isolation of the DTPA-labeled Fab fragment using an antigen affinity column. While DTPA-Fab forms of our antibodies will first be used to examine targeting of ⁹⁹Tc to tumors in mice, all of these studies with monoclonal antibodies are aimed at moving our basic research findings over to patient care. Funding has been requested for such translational research.

Cloning of a novel calcium-mobilizing receptor from cancer cells (NCI H146 SCCL cells and MCF7 breast cancer cells)

Three years ago we described our ability to demonstrate, for breast cancer cells, the expression of mRNA for the novel vasopressin receptor, called VACM, using RT-PCR and primers designed from the structure of the rabbit form of this protein. Since that time the structure of a human clone of VACM from placenta was published by a British research team (Byrd et al., 1997, Stankovic et al., 1997). In order to study the role of this putative receptor in breast cancer, we generated a cDNA clone from human cancer cells. Initial efforts were focused on the small-cell carcinoma cell line NCI-H146, because we had obtained signal transduction data the presence of functional VACM protein in these cells. However, we then obtained 5' and 3' RACE products covering the entire open reading frame of mRNA for the protein from MCF7 breast cancer cells. The primers employed in RACE are given in Table 6, below:

TABLE 6: Primers used for 5' and 3' RACE of VACM from MCF7 breast cancer cells

3'-PCR RACE primers

1432(forward)	5' gaa-tgg-cta-aga-gaa-gtt-ggt-atg 3'
138 (reverse)	5' ttg-ttt-ttg-taa-ggt-aag-gca-gag 3'

5'-PCR RACE primers

5' ATG (forward)	5' tcc-aag-tta-aag-aac-atg-gcg 3'
2082 (reverse)	5' tct-tct-ctc-ctc-ctt-tct-gta-gtg 3'

The isolated VACM clone for NCI-H146 contains an open reading frame of 2,343 nucleotides and encodes a protein of a predicted size of 781 amino acids. Analysis programs failed to identify hydrophobicity regions of sufficient confluence to classify them as transmembrane regions. The following motifs were identified to be present in the protein structure: two protein kinase A phosphorylation domains (Thr 427 and Ser 731); 15 protein kinase C phosphorylation domains; a Tyrosine phosphorylation domain (Tyr 207); two myristoylation sites between residues 180 and 185, and 664 and 669; and three glycosylation sites at Asn 145, Asn 289, and Asn 566. Although **these findings are unpublished** we have recently submitted a manuscript on the structure of HVACM in H146 cells. **Our cDNA sequence for what we are now referring to as HVACM from human cancer cells has been submitted to the GENEbank by us and has been assigned the accession number AF017061.** A complete copy of the GENEbank submission is included in the appendix of this progress report. The availability of cloned HVACM should now allow us to examine in detail the expression of this putative vasopressin receptor, and determine its role in the vasopressin-induced mitogenesis of breast cancer. We have also had antibodies made to HVACM, and these will be used to examine the incidence and distribution of the protein in breast cancer from our archival library. We recently determined expression of HVACM by normal tissues using immunohistochemistry.

Vasopressin-induced phosphorylation (activation) of mitogen-activated protein kinase (MAPK).

We earlier reported that vasopressin can activate MAPK in breast cancer cells, and we have recently tried to provide quantitative data on MCF7 breast cancer cells using a fluorescence Western Blot procedure from ECL with a Molecular Dynamics Fluorimager. Two antibodies preparations employed recognize dually phosphorylated MAPK p42/p44 (activated MAPK), and MAPK regardless of phosphorylation status. Treatments with vasopressin and a vasopressin V1 antagonist for 5 and 15 minutes were compared with controls using Imagequant software. Data obtained support an increase in MAPK activation at 5 minutes, but not at 15 minutes, and this increase could only be demonstrated for the p44 MAPK isoform. **These data have not yet been published.**

Sequencing of the vasopressin V1 and V2 receptor subtypes of breast cancer cells.

We earlier reported on the presence of vasopressin V_{1a}, V_{1b}, and V₂ receptors, and oxytocin receptors in breast cancer cell lines BT 549, MCF7, MDA, MB-231, T47D, and ZR-75 using specific primers and RT-PCR. **We have now obtained sequences for the entire open reading frames (ORFs) of mRNAs for the all vasopressin receptors (three normal and one abnormal) for the MCF-7 and ZR-75 breast cancer cell lines. Complete sequence information on the open reading frames of all of these receptors produced by small-cell carcinoma of the lung were earlier published and submitted to the Genebank with accession numbers AF030625, AF030512, AF030626, and AF032388. We have now entered our breast cancer data into the Genebank under accession numbers AF101725, AF101726, AF101727, and AF101728. This breast cancer receptor data has now been published (North, Fay, Du, 1999).**

Using forward and reverse primers selected to provide overlapping sequences covering the entire open reading frames (ORFs) of vasopressin V_{1a}, and V_{1b} mRNAs, RT-PCR of poly(A)⁺ RNA preparations from MCF-7 cells yielded, in each case, a single product of the expected size predicted from the cDNA for the human forms of these receptors derived from liver (Thibonnier et al., 1994) or blood vessels (Hirasawa et al., 1994), from pituitary (Sugimoto et al., 1994; de Keyzer et al., 1994); and from small-cell lung cancer (North et al., 1998). All of the products were generated from RNA and not DNA template because no intronic segments that these products spanned were evident. The product obtained for the V_{1a} receptor (1472 bp), and the three obtained for the V_{1b} receptor are shown in the figure below. However, RT-PCR with forward and reverse primers selected to obtain overlapping sequences covering the entire sequence of vasopressin V₂ mRNA gave not only normal products (Birnbaumer et al., 1993), but also one abnormally sized product. The abnormal form was obtained as a second product when primers spanning intron 2 were used and was larger by the size of this intron (~100 bp) than the size of 862 bp, predicted from the structure of V₂ receptor mRNA. A similar product was earlier reported by us to be a product of small-cell lung cancer (North et al., 1998). Cloning and sequencing of V_{1a} and V_{1b} related products, and V₂ related products of predicted size, showed them to collectively provide a complete

characterization of human V_{1a} mRNA for the MCF-7 breast cancer cell line from -23 at the 5' end (23 bases prior to the reading frame) through 1224 at the 3' end (18 bases beyond the reading frame), for V_{1b} mRNA from 123 bases beyond the 5' end to 52 bases beyond the 3' end, and for V_2 mRNA from 32 bases beyond the 5' end to 53 bases beyond the 3' end. The sequences for the vasopressin V_1 receptor mRNAs had exact sequence homology with the sequence of human V_{1a} mRNA and the sequence of human V_{1b} mRNA published earlier by us and others (North et al., 1998; Thibonnier et al., 1994; Sugimoto et al., 1994; de Keyser et al., 1994). One sequence of human V_2 receptor mRNA from breast cancer cells was identical to that published by us and others for normal human tissues (Fay et al., 1996; Birnbaumer et al., 1993). Additionally, an enlarged product of the V_2 receptor was found to contain the entire 106 bases of intron 2 in addition to sequence for V_2 mRNA.

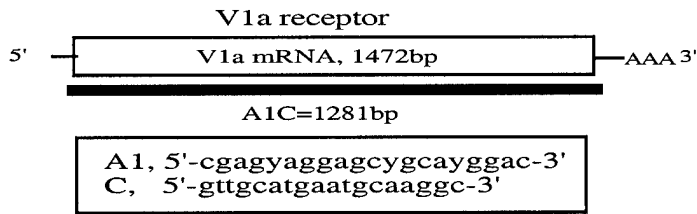

Figure 8: RT-PCR primers and products of vasopressin receptors in MCF-7 breast cancer cells

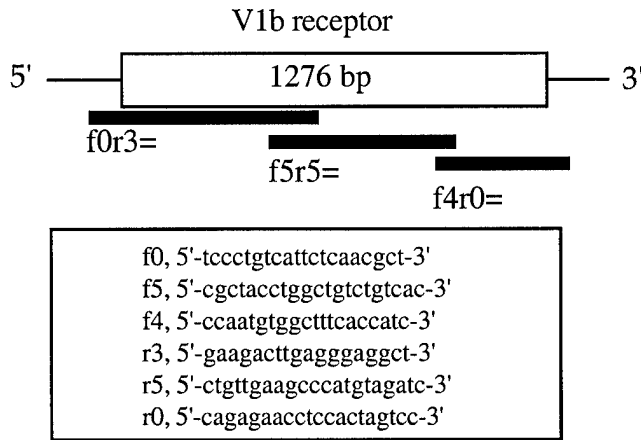

Figure 8: RT-PCR primers and products of vasopressin receptors in MCF-7 breast cancer cells

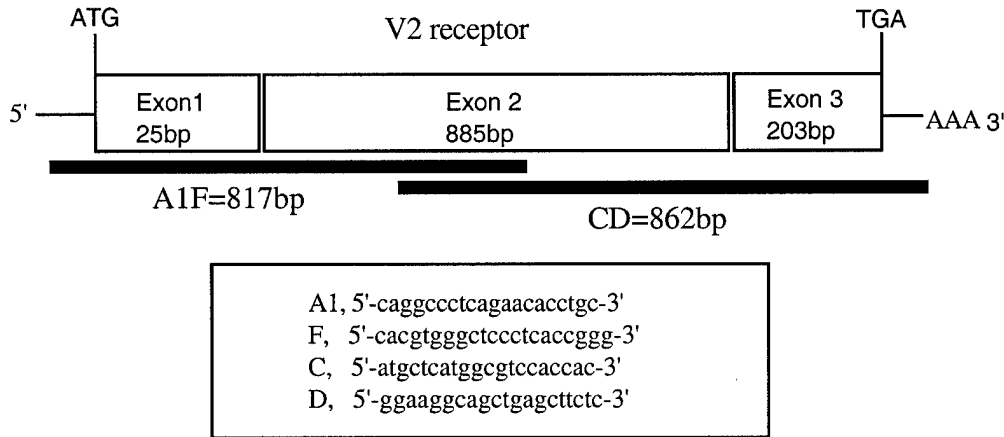

Figure 8: RT-PCR primers and products of vasopressin receptors in MCF-7 breast cancer cells

(7) KEY RESEARCH ACCOMPLISHMENTS

- **Discovered most likely all breast cancers express the vasopressin gene**
- **Discovered normal breast tissue and breast fibrocystic conditions are not associated with vasopressin gene expression**
- **Discovered most likely all carcinoma in situ express the vasopressin gene**
- **Concluded vasopressin gene expression is part of the oncogenic process in breast, and can be potentially used in a new screening method for distinguishing carcinoma in situ from atypical ductal hyperplasia**
- **Discovered vasopressin gene expression leads to formation of 20 Kda and 40 Kda surface markers we have named GRSA that can be potentially used to as targets for immunotherapy and immunodiagnosis. One of these is provasopressin**
- **Developed monoclonal antibodies against VAG for immunohistochemical screening and for targeting treatments**
- **Discovered most vasopressin gene-related proteins expressed by breast cancer cells are products of a normal vasopressin gene**
- **Demonstrated all of the essential enzymes involved in processing peptide precursors (PCs, PAM, CPE) are expressed by breast cancer and these seem to have normal structures**
- **Demonstrated that most trafficking of vasopressin translation products seems to be outside conventional secretory vesicles with most products targeted to the plasma membrane**
- **Discovered many, but not all, breast cancers express the oxytocin gene**
- **Discovered that all recognized vasopressin receptors (V1a, V1b, V2) are expressed by breast cancers. Determined all of these receptors are normal and probably functional. However in addition breast cancers express a partially spliced V2mRNA that gives rise to an abnormal V2 receptor that lacks the seventh transmembrane region**
- **Generated polyclonal antibodies against normal V1a, V1b and V2 receptors, and against the abnormal receptor**
- **Discovered and first sequenced the human vasopressin activated calcium mobilizing receptor (HVACM, now referred to as Cullin 5) and identified this protein as being expressed by breast cancer**
- **Determined vasopressin increases MAP kinase and focal adhesion kinase activities in breast cancer cells**
- **Examined the influence of oxytocin on breast cancer cells**

(8) REPORTABLE OUTCOMES

– manuscripts, abstracts, presentations;

Manuscripts:

North, W.G., Pai, S., Friedmann, A., Yu, X., Fay, M., and Memoli, V. Vasopressin gene related products are markers of human breast cancer. *Breast Cancer Research and Treatment* 34:229-235, 1995.

Fay, M.J., Du, J., Yu, X., and North, W.G. Evidence for expression of vasopressin V₂ receptor mRNA in human lung. *Peptides* 17(3):477-481, 1996.

Gallagher, J.D., Fay, M.J., North, W.G., and McCann, F.V. Ionic signals in T47D human breast cancer cells. *Cellular Signalling* 8(4):279-284, 1996.

Fay, M.J., Mathew, R.S., Donnelly, E.M., Memoli, V.A., and North, W.G. Immunohistochemical evaluation of vasopressin gene expression in fibrocystic breast disease. *Endocrine Pathology*, In Press, 1999.

North, W.G., Fay, M.J., and Du, J. MCF-7 breast cancer cells express normal forms of all vasopressin receptors plus an abnormal V2R. *Peptides* 20:837-842, 1999.

Du, J. and North, W.G. Breast cancer cells express key processing enzymes. *Breast Cancer Res. Treat.* Submitted, 1999.

Fay, M.J., Du, J., Longo, K.A., and North, W.G. Oxytocin does not induce a rise in intracellular free calcium in human breast cancer cells. *J. Res. Commun. Mol. Path. Pharmacol.*, 103:115-129, 1999.

Longo, K.A., Fay, M.J., Chen, H.T., Memoli, V.A., and North, W.G. Tissue specific expression of HVACM/CUL-5, a cullin protein, in humans. *Jour. Immuno. Chem.*, Submitted, 1999.

Longo, K.A., Fay, M.J., Du, J., and North, W.G. Small cell lung cancer expresses a functional form of VACM-1, a putative vasopressin receptor and cullin family member. Submitted to *Biochim. Biophys. Acta*, 1999.

Presentations and abstracts:

Fay, M.J., Yu, X., Memoli, V. and North, W.G. Expression of the vasopressin gene by human breast cancer. *Mol. Biol. Cell* 5:2730, 1994.

Fay, M.J., Yu, X., Memoli, V. and North, W.G. Expression of the vasopressin gene by human breast cancer. Gordon Conference, Mammary Gland Biology. Colby Sawyer College, New London, NH. June 18-23, 1995.

Longo, K.A., Fay, M.J., Du, J. and North, W.G. Evidence for the expression of a novel vasopressin-activated calcium mobilizing receptor (VACM-1) in human breast cancer and lung cancer. *Mol. Biol. Cell* 7:3761, 1996.

North, W.G., Fay, M.J. and Du, J. Vasopressin and breast cancer, gene expression and trafficking. Summer neuropeptide conference, Key West, Florida. June 21-26, 1997.

Longo, K.A., North, W.G., Du, J. and Fay, M.J. Evidence for the expression of a novel vasopressin-activated calcium mobilizing receptor (HVACM) in human breast cancer and lung cancer cell lines. World Cong. of Neurohypophysial Horm., Montreal, Canada. Aug. 8-12, 1997.

North, W.G. and Du, J. Production and processing of vasopressin gene-related proteins by neuroendocrine tumors. Proc. Soc. Neuro. Sci. 23:63.4, 1997.

North, W.G., Fay, M.J., Longo, K. and Du, J. Vasopressin gene-related products in the management of breast cancer. DOD Breast Cancer Research Program Meeting: Era of Hope Proceedings, 2:795-796, 1997.

Fay, M., Du, J., Longo, K. and North, W. The role of vasopressin and oxytocin hormones in breast cancer. DOD Breast Cancer Research Program Meeting: Era of Hope Proceedings, 2:797-798, 1997.

North, W.G. Gene Regulation of Vasopressin and Vasopressin Receptors in Cancer. Proceedings World Congress on Neurohypophyseal Hormones, Edinburgh September, 1999, Experimental Physiology, 1999.

Du, J. and North, W.G. Breast cancer cells express normal forms of all vasopressin receptors plus an abnormal V2R. Proc. Amer. Assoc. Cancer Res. A 1175, 1999.

Review articles:

North, W.G. Gene Regulation of Vasopressin and Vasopressin Receptors in Cancer. Experimental Physiology, in press, 1999.

– patents and licenses applied for and/or issued;

RCT Disclosure No.: 149-B340-99

Inventor: William G. North

Title: "Detection and targeting of breast cancer and carcinoma in situ using antibodies against an abnormal form of the vasopressin V2 receptor"

RCT Disclosure No.: 149-B34299

Inventor: William G. North

Title: "A method for distinguishing breast carcinoma in situ from atypical ductal hyperplasia using antibodies against vasopressin or against vasopressin-associated glycopeptide (VAG) copeptin."

Title: Use of monoclonal antibodies against vasopressin-associated glycopeptide (referred to here as MAGs), and modified forms of these MAGs, for: a) Screening fresh and fixed biopsied material for the presence of breast cancer; b) Radiodiagnostic imaging of breast cancer in patients and; c) Targeting therapy of breast cancer in patients.

RCT Disclosure No.: 149-B352-99

Inventor: William G. North

Title: "A single method is introduced for a) Distinguishing breast carcinoma in situ and breast cancer carcinoma in situ and breast cancer from atypical ductal hyperplasia, and for b) the early detection of small-cell lung cancer and distinguishing small-cell lung cancer from normal lung performing RT-PCR for VPmRNA on RNA from biopsied material and fixed material from stored tissue blocks."

– Degrees obtained that are supported by this award;

Kenneth A. Longo, Ph.D.

Received his Ph.D. degree in August of 1998.

- development of cell lines, tissue or serum repositories;

None.

- informatics such as databases and animal models, etc;

AF 101725

Homo sapiens vasopressin receptor subtype 1a mRNA, complete cds

gi\4336679\gb\AF101725.1\AF101725 [4336679]

(View [GenBank report](#), [FASTA report](#), [ASN.1 report](#), [Graphical view](#), [1 MEDLINE link](#), [1 protein link](#), or [19 nucleotide neighbors](#))

AF 101726

Homo sapiens vasopressin receptor subtype 1b mRNA, complete cds

gi\4336681\gb\AF101726.1\AF101726 [4336681]

(View [GenBank report](#), [FASTA report](#), [ASN.1 report](#), [Graphical view](#), [1 MEDLINE link](#), [1 protein link](#), or [6 nucleotide neighbors](#))

AF 101727

Homo sapiens vasopressin receptor type 2 mRNA, complete cds

gi\4323604\gb\AF101727.1\AF101727 [4323604]

(View [GenBank report](#), [FASTA report](#), [ASN.1 report](#), [Graphical view](#), [1 MEDLINE link](#), [1 protein link](#), or [10 nucleotide neighbors](#))

AF 101728

Homo sapiens truncated vasopressin receptor type 2 mRNA, complete cds

gi\4323606\gb\AF101728.1\AF101728 [4323606]

(View [GenBank report](#), [FASTA report](#), [ASN.1 report](#), [Graphical view](#), [1 MEDLINE link](#), [1 protein link](#), or [8 nucleotide neighbors](#))

- funding applied for based on work supported by this award;

DOD Translational Grant

Vasopressin Gene-Related Products in the Clinical Management of Breast Cancer

PI: William G. North, Ph.D.

04/01/00 - 03/31/04

Under review

NIH/NCI

Vasopressin in the Radiodiagnosis of Breast Cancer

PI: William G. North, Ph.D.

04/01/00 - 03/31/05

Under review

- employment or research opportunities applied for and/or received on experiences/training supported by this award.

DOD Postdoctoral Fellowship

Michael J. Fay, Ph.D.

Equipment, supplies and facilities support.

(9) CONCLUSIONS

The studies conducted over this final and extended year of the granting period have included focus on completing the sequencing and Western evaluations of vasopressin receptors in MCF7 and ZR-75 breast cancer cell lines, plus performing sequencing and Western evaluations of processing enzymes in MCF7 and ZR-75 breast cancer cells and publishing the data; generating monoclonal antibodies against vasopressin-associated glycopeptide (VAG) and evaluating these antibodies; and establishing the methodology for generating Fab fragments with DTPA side-groups for ⁹⁹Tc labeling from IgG1 and IgG2a monoclonal antibodies. These last studies are aimed at moving basic research findings over to patient screening, diagnosis, and treatment. All of the findings over the five years of the funding period have further confirmed our original hypothesis that all breast cancers produce vasopressin as an autocrine growth factor, and that this property can be utilized to develop more successful treatments. Expression of the vasopressin gene seems to be associated with all oncogenic transformation of breast tissue as evidenced by the presence of vasopressin gene products in all breast cancers examined, the absence of these products from all varieties of fibrocystic disease, and our demonstration that all carcinoma in situ (DCIS) examined expressed these same products. We our findings can have short-term clinical application in providing earlier detection of breast cancer as an effective way to distinguish atypical intraductal hyperplasia from carcinoma in situ. There is no other simple one-step method available for making this distinction.

When vasopressin gene(s) are expressed by breast cancers, they give rise to normal and abnormal products. Studies conducted by us on trafficking of vasopressin gene-related products by breast cancer cells has revealed that about nine-tenths of the proteins become components of the plasma membrane able to provide targets for antibodies in patients. These proteins comprise both a 40 KDa and 20 KDa form. Antibodies against one of the recognized abnormal structures in these vasopressin gene-related proteins are now being produced. Such new or already available antibodies should be potentially useful in later planned immunodiagnosis and immunotherapies. Alternatively, antibodies already available to normal VP-related structures should also be effective for targeting breast cancer in patients.

Vasopressin seems to have a multifaceted role on the growth and physiology of breast cancer cells because we have demonstrated that all known forms of vasopressin receptor subtypes are expressed by these cells. The complete sequences of a putative receptor named hVACM has been determined by us and entered in the Genebank. Structures for vasopressin V_{1a}, V_{1b}, V₂, and abnormal V₂ receptors have also been determined. Sequence data shows they have the same sequences submitted to the Genebank by us for vasopressin receptor subtypes produced by small-cell carcinoma cells. We have further demonstrated that through one or more of these receptors, vasopressin is able to alter calcium homeostasis and activated MAP kinase in breast cancer cells.

Although this represents the final report, we are hoping we can now move our studies over to patient care through funding for translational research currently being evaluated. In vitro studies related to regulation of vasopressin gene expression and satisfying task 5 of the original statement of work were not conducted because of a recent conclusion these will have little bearing on expression in vivo (see North, 1999); nor did we perform those related to binding of polyclonal antibodies by cancer cells in vitro and in vivo, as designed to satisfy task 6 in the original statement of work. In the latter case we felt it was more important to devote effort to generating monoclonal antibodies that will better serve future patient care. Binding studies will now be conducted with these monoclonal antibodies. We also anticipate publishing more of the above data and will forward such publications as they arise.

So What Section

It is likely the knowledge gained through this research will result in a new and simple screening method that distinguishes carcinoma in situ from atypical ductal hyperplasia (patent pending), the availability of monoclonal antibodies that are effective tools for diagnosis and treatment (patent pending), new an effective immunological methods for detecting recurrent breast cancer and for treating breast cancer by targeting GRSA proteins or the abnormal vasopressin V₂ receptor we have discovered (patent pending),

and new and effective methods of treating breast cancer through the use of vasopressin antagonists. Many of these potential translational outcomes form part of an application under review for funding by the Department of Defense.

10) REFERENCES

- Altschul, S.F., Warren, G., Miller, W., Myers, E.W., Lipman, D.J. *J. Mol. Biol.*, **215**:410 (1990).
- Birnbaumer, M., Seibold, A., Gilbert, S. Ishido, M., Barberis, C., Antaramian, A., Brabet, P., Rosenthal, W. *Nature*, **357**:333 (1992).
- Birnbaumer, M., Siebold, A., Rosenthal, W., Bichet, D.G. The human ADH receptor: the gene, the cDNA, the protein. *In*: P.Gross, D. Richter, G.I. Robertson (eds.), *Vasopressin*, pp.19-31. John Libbey Eurotext, Paris.(1993)
- Bunn, P.A., Dienhart, D.G., Chan, D., Tagawa, M., and Jewett, P. *Monogr. Natl. Cancer Inst.*, **13**:145 (1992).
- Bradford, M.M. *Analytical Biochem.*, **72**:248 (1976).
- Burnatowska-Hledin, M.A., Spielman, W.S., Smith, W.L., Shi, P., Meyer, J.M., Dewitt, D.L. *Am. J. Physiol.*, **268**:1198 (1995).
- Bussolati, G., Cassoni, P., Ghisolfi, G., Negro, F., and Sapino, A. *Am. J. Pathol.*, **148**:1895 (1996).
- Byrd, P.J., Stankovic, T., McConville, C.M., Smith, A.D., Cooper, P.R., and Taylor, A.M. *Genome Res.*, **7**:71-75 (1997).
- Cassoni, P., Sapino, A., Negro, F., and Bussolati, G. *Virchows Archiv.*, **425**:467 (1994).
- Cassoni, P., Sapino, A., Papotti, M., Bussolati, G. *Int. J. Cancer*, **66**:817 (1996).
- Cassoni, P., Sapino, A., Fortunati, N., Munaron, L., Chini, B., and Bussolati, G. *Int. J. Cancer*, **72**:340-344, 1997.
- Cheng, M., Watson, P.H., Paterson, J.A., Seidah, N., Cretien, M., and Shui, R.P. *Int.J. Cancer*, **966**-971 (1997).
- Choi, K., Carter, D.A., Biswas, S., Lightman, S.L., Ho, M., and Murphy, D. *Cancer Res.*, **54**:6434 (1994).
- Clark, E.A., Bruggge, J.S. *Science*, **268**:233 (1995).
- Cobb, M.H. and Goldsmith, E.J. *J. Biol. Chem.*, **270**:14843-14846 (1995).
- Colditz, G.A. *Cancer Supplement*, **71**:1480 (1993).
- de Keyzer, Y., Auzan, C., Lenne, F., Beldjord, C., Thibonnier, M., Bertagna, X., Clauser, E. *FEBS Lett.* **356**:215-220 (1994).
- Dubois J.M., Rouzair-Dubois, B. *Prog. Biophys. Mol. Biol.*, **59**:1 (1993).
- *Fay, M.J., Friedmann, A.S., Yu, X., North, W.G. *Cancer Letters*, **82**:167 (1994).
- * Fay, M.J., Du, J., Yu, X., and North, W.G. *Peptides* **17**:477-481 (1996)..

- * Fay M.J., Mathew, R.S., Donnelly, E.M., Memoli, V.A., and North, W.G. Immunohistochemical evaluation of vasopressin gene expression in benign breast disease: Preliminary Observations. *Endocrine Pathology*, In Press (1997).
- Fay, M.J., Du, J., Yu, X., North, W.G. *Peptides* 17:477-481.(1996)
- *Friedmann, A.S., Malott, K.A., Memoli, V.A., Pai, S.I., Yu, X., and North, W.G., *Br. J. Cancer*, **69** 260 (1994).
- *Gallagher, J.D., Fay, M.J., North, W.G., and McCann, F.V., *Cell. Signal.*, **8** 279 (1996).
- Gross, A.J., Steinberg, S.M., Reilly, J.G., Bliss, D.P., Brennan, J., Tramble, P., Simmons, A., Phelps, R., Mulshine, J.L., Ihde, D.C., and Johnson, B.E. *Cancer Res.*, **53**:67 (1993).
- Grynkiewick, G. Poenie, M., and Tsien, R.Y. *J. Biol. Chem.* **260**:3440 (1995).
- Guillon, G., Kirk, C.J., and Balestre, M. *Biochem. J.*, **240**:189 (1986).
- Gupta, A., Sasarula, S., Rao, P.V. *J. Assoc. Physicians India*, **34**:441 (1986).
- Hirasawa, A., Shibata, K., Kotosai, K., Tsujimoto, G. *Biochem. Biophys. Rs. Commun.*, **203**:72 (1994).
- Hong, M., Moody, T.W. *Peptides*, **12**:1315 (1991).
- Howard, A.C., Laing, R.W., and Hussain, F.N. *Eur. J. Cancer*, **29A**:2339 (1993).
- Ito, Y., Kobayashi, T., Kimura, T., Matsuura, N., Wakasugi, E., Takeda, T., Shimano, T., Kubota, Y., Nobunaga, T., Makino, Y., Azuma, C., Saji, F. *Endocrinol.*, **137**:773 (1996).
- Janmey, P.A. *Annu. Rev. Physiol.*, **56**:169 (1994).
- Kirk, C.J., Guillon, G., Balestre, M., and Jard, S. *Biochem. J.*, **240**:197 (1986).
- Lopez-Ilasaca M., Crespo, P., Guiseppe-Pellici, P., Silvio-Gutkind, J., and Wetzker, R. *Science*, **275**:394-397 (1997).
- Monaco, M.E., Lippman, M.E., Knazek, R., and Kidwell, W.R. *Cancer Res.* **38**:4101 (1978).
- Monaco, M.E., Kidwell, W.R., and Lippman, M.E. *Biochem J.*, **188**:437 (1980).
- *North, W.G. *J. Clin. Endocrinol. Metab.* **73**:1316 (1991).
- *North, W.G., and Yu, X.M. *Peptides*, **14**:303 (1993).
- *North, W.G., Pai, S., Friedmann, A., Yu, X., Fay, M., and Memoli, V. *Breast Cancer Res. Treatment* **34**:229 (1995).
- *North, W.G., Fay, M.J., Longo, K., and Du, J. *Peptides*, **18**: 985-993 (1997).
- *North, W.G., Fay, M.J., Longo, K., Du, J. 1998 Expression of all known vasopressin receptor subtypes by small cell tumors implies a multifaceted role for this neuropeptide. *Cancer Res.* **58**:1866-1871.
- *North, W.G., Fay, M.J., and Du, J. MCF-7 breast cancer cells express normal forms of all vasopressin receptors plus an abnormal V2R. *Peptides* **20**:837-842, 1999.

*Du, J. and North, W.G. Breast cancer cells express key processing enzymes. *Breast Cancer Res. Treat.* Submitted , 1999.

*North, W.G. Gene Regulation of Vasopressin and Vasopressin Receptors in Cancer. In Proceedings World Congress on Neurohypophyseal Hormones, Edinburgh September, 1999, *Experimental Physiology*, 1999.

Owens, L.V., Xu, L., Craven, R.J., Dent, G.A., Weiner, T.M., Kornberg, L., Liu, E.T., and Cance, W.G. *Cancer Res.*, **55**:2752 (1995).

Rosenbaum, L.C., Neuwelt, E.A., Van Tol, H.H.M., Loh, Y.P., Verbalis, J.G., Helstrom, I., Helstrom, K.E., and Nilaver, G. *Proc. Natl. Acad. Sci. USA*, **87**:9928 (1990).

Sausville, E., Carney, D., and Battey, J. *J. Biol. Chem.*, **260**:10236 (1985).

Sethi, T. and Rozengurt, E. *Cancer Res.*, **51**:3621 (1991).

Simon, H., Gao, Y., Franki, N., Hays, R.M. *Am. J. Physiol.* **265**:c757 (1993).

Sinnett-Smith, J., Zachary, I., Valverde, and Rozengurt, E. *J. Biol. Chem.*, **268**:14261 (1993).

Sugimoto, T., Saito, M., Mochizuki, S., Watanabe, Y., Hashimoto, S., Kawashima, H. *J. Biol. Chem.*, **269**:27088 (1994).

Taylor, H., Ang, V.T.Y., Jenkins, J.S., Silverlight, J.J., Coombes, R.C., and Laqmani, Y.A. *Cancer Res.*, **50**:7882 (1990)

Thibonnier, M., Auzan, C., Madhun, Z., Wilkins, P., Berti-Mattera, L., Clausers, E. *J. Biol. Chem.*, **269**:3304 (1994).

Woods, D.J. and Monaco, M.E., *Mol. Endocrinol.*, **2**:350 (1988).

Zachary, I., Sinnett-Smith, J., and Rozengurt, E. *J. Biol. Chem.*, **266**:24126 (1991).

Zachary, I., Sinnett-Smith, J., and Rozengurt, E. *J. Biol. Chem.*, **267**:19031 (1992).

Zachary, I., Sinnett-Smith, J., Turner, C., and Rozengurt, E. *J. Biol. Chem.*, **268**:22060 (1993).

(11) BIBLIOGRAPHY AND PERSONNEL

Manuscripts:

North, W.G., Pai, S., Friedmann, A., Yu, X., Fay, M., and Memoli, V. Vasopressin gene related products are markers of human breast cancer. *Breast Cancer Research and Treatment* 34:229-235, 1995.

Fay, M.J., Du, J., Yu, X., and North, W.G. Evidence for expression of vasopressin V₂ receptor mRNA in human lung. *Peptides* 17(3):477-481, 1996.

Gallagher, J.D., Fay, M.J., North, W.G., and McCann, F.V. Ionic signals in T47D human breast cancer cells. *Cellular Signalling* 8(4):279-284, 1996.

Fay, M.J., Mathew, R.S., Donnelly, E.M., Memoli, V.A., and North, W.G. Immunohistochemical evaluation of vasopressin gene expression in fibrocystic breast disease. *Endocrine Pathology*, In Press, 1999.

North, W.G., Fay, M.J., and Du, J. MCF-7 breast cancer cells express normal forms of all vasopressin receptors plus an abnormal V2R. *Peptides* 20:837-842, 1999.

Du, J. and North, W.G. Breast cancer cells express key processing enzymes. *Breast Cancer Res. Treat.* Submitted, 1999.

Fay, M.J., Du, J., Longo, K.A., and North, W.G. Oxytocin does not induce a rise in intracellular free calcium in human breast cancer cells. *J. Res. Commun. Mol. Path. Pharmacol.*, 103:115-129, 1999.

Longo, K.A., Fay, M.J., Chen, H.T., Memoli, V.A., and North, W.G. Tissue specific expression of HVACM/CUL-5, a cullin protein, in humans. *Jour. Immuno. Chem.*, Submitted, 1999.

Longo, K.A., Fay, M.J., Du, J., and North, W.G. Small cell lung cancer expresses a functional form of VACM-1, a putative vasopressin receptor and cullin family member. Submitted to *Biochim. Biophys. Acta*, 1999.

Presentations and abstracts:

Fay, M.J., Yu, X., Memoli, V. and North, W.G. Expression of the vasopressin gene by human breast cancer. *Mol. Biol. Cell* 5:2730, 1994.

Fay, M.J., Yu, X., Memoli, V. and North, W.G. Expression of the vasopressin gene by human breast cancer. Gordon Conference, Mammary Gland Biology. Colby Sawyer College, New London, NH. June 18-23, 1995.

Longo, K.A., Fay, M.J., Du, J. and North, W.G. Evidence for the expression of a novel vasopressin-activated calcium mobilizing receptor (VACM-1) in human breast cancer and lung cancer. *Mol. Biol. Cell* 7:3761, 1996.

North, W.G., Fay, M.J. and Du, J. Vasopressin and breast cancer, gene expression and trafficking. Summer neuropeptide conference, Key West, Florida. June 21-26, 1997.

Longo, K.A., North, W.G., Du, J. and Fay, M.J. Evidence for the expression of a novel vasopressin-activated calcium mobilizing receptor (HVACM) in human breast cancer and lung cancer cell lines. World Cong. of Neurohypophysial Horm., Montreal, Canada. Aug. 8-12, 1997.

North, W.G. and Du, J. Production and processing of vasopressin gene-related proteins by neuroendocrine tumors. *Proc. Soc. Neuro. Sci.* 23:63.4, 1997.

North, W.G., Fay, M.J., Longo, K. and Du, J. Vasopressin gene-related products in the management of breast cancer. DOD Breast Cancer Research Program Meeting: Era of Hope Proceedings, 2:795-796, 1997.

Fay, M., Du, J., Longo, K. and North, W. The role of vasopressin and oxytocin hormones in breast cancer. DOD Breast Cancer Research Program Meeting: Era of Hope Proceedings, 2:797-798, 1997.

North, W.G. Gene Regulation of Vasopressin and Vasopressin Receptors in Cancer. Proceedings World Congress on Neurohypophyseal Hormones, Edinburgh September, 1999, Experimental Physiology, 1999.

Du, J. and North, W.G. Breast cancer cells express normal forms of all vasopressin receptors plus an abnormal V2R. Proc. Amer. Assoc. Cancer Res. A 1175, 1999.

Review articles:

North, W.G. Gene Regulation of Vasopressin and Vasopressin Receptors in Cancer. Experimental Physiology, in press, 1999.

Personnel Associated with this Project: The following persons contributed to the studies outlined in this report. They and/or their work received support from the award made through DOD for breast cancer research.

William G. North Ph.D. Professor of Physiology
Principal Investigator October 1994 to September 1999, 30% Salary through 1998/ 30% Effort

Vincent Memoli MD. Professor of Pathology
Associate Investigator, No salary support, As needed
October 1994 to September 1999

Frances McCann Ph.D. Professor of Physiology
Associate Investigator, No salary support, As needed
October 1994 to September 1999

John Gallagher MD. Professor of Anesthesiology
Associate Investigator, No salary support, As needed
October 1994 to September 1999

Jinlin Du MD. Research Associate
October 1994 to December, 1996, 50% Salary/50% Effort
December, 1996 to July, 1998, 100% Salary/100% Effort

Susan Gagnon B.A. Research Assistant
December 1997, 50% Support/50% Effort
January 1998 to July 1998, 100% Salary/100% Effort

Timothy Moser M.A. Technical Assistant
February 1995 to October 1995, 100% Salary/100% Effort

Alison North Technical Assistant
December 1996 to September 1999, 50% Salary/100% Effort

Matthew Brennan Graduate Assistant
September 1998 to June 1999, 100% Salary/100% Effort

Michael J. Fay Ph.D. Postdoctoral Fellow with DOD Funding
October 1994 to September 1997, No salary support, Support Equipment/Supplies

Student Contributors:

Andrew S. Friedmann, Graduate Student
October 1994 to June 1995

Kenneth Longo, Graduate Student
December 1994 to August 1998

Joanne Bates, Graduate Student
August 1995 to January 1996

Katherine Hinz, Graduate Student
August 1997 to January 1998

Sara Pai, Undergraduate Student
October 1994 to June 1995

APPENDIX

Publications

North, W.G., Pai, S., Friedmann, A., Yu, X., Fay, M., and Memoli, V. Vasopressin gene related products are markers of human breast cancer. *Breast Cancer Research and Treatment* 34:229-235, 1995.

Gallagher, J.D., Fay, M.J., North, W.G., and McCann, F.V. Ionic signals in T47D human breast cancer cells. *Cellular Signalling* 8(4):279-284, 1996.

Fay, M.J., Mathew, R.S., Donnelly, E.M., Memoli, V.A., and North, W.G. Immunohistochemical evaluation of vasopressin gene expression in fibrocystic breast disease. *Endocrine Pathology*, In Press, 1999.

North, W.G., Fay, M.J., and Du, J. MCF-7 breast cancer cells express normal forms of all vasopressin receptors plus an abnormal V2R. *Peptides* 20:837-842, 1999.

Du, J. and North, W.G. Breast cancer cells express key processing enzymes. *Breast Cancer Res. Treat.* Submitted, 1999.

Fay, M.J., Du, J., Longo, K.A., and North, W.G. Oxytocin does not induce a rise in intracellular free calcium in human breast cancer cells. *J. Res. Commun. Mol. Path. Pharmacol.*, 103:115-129, 1999.

Longo, K.A., Fay, M.J., Chen, H.T., Memoli, V.A., and North, W.G. Tissue specific expression of HVACM/CUL-5, a cullin protein, in humans. *Jour. Immuno. Chem.*, Submitted, 1999.

Longo, K.A., Fay, M.J., Du, J., and North, W.G. Small cell lung cancer expresses a functional form of VACM-1, a putative vasopressin receptor and cullin family member. Submitted to *Biochim. Biophys. Acta*, 1999.

North, W.G. Gene Regulation of Vasopressin and Vasopressin Receptors in Cancer. *Experimental Physiology*, in press, 1999.

Abstracts from National Meetings

Fay, M.J., Yu, X., Memoli, V. and North, W.G. Expression of the vasopressin gene by human breast cancer. *Mol. Biol. Cell* 5:2730, 1994.

Fay, M.J., Yu, X., Memoli, V. and North, W.G. Expression of the vasopressin gene by human breast cancer. Gordon Conference, Mammary Gland Biology. Colby Sawyer College, New London, NH. June 18-23, 1995.

Longo, K.A., Fay, M.J., Du, J. and North, W.G. Evidence for the expression of a novel vasopressin-activated calcium mobilizing receptor (VACM-1) in human breast cancer and lung cancer. *Mol. Biol. Cell* 7:3761, 1996.

North, W.G., Fay, M.J. and Du, J. Vasopressin and breast cancer, gene expression and trafficking. Summer neuropeptide conference, Key West, Florida. June 21-26, 1997.

Longo, K.A., North, W.G., Du, J. and Fay, M.J. Evidence for the expression of a novel vasopressin-activated calcium mobilizing receptor (HVACM) in human breast cancer and lung cancer cell lines. World Cong. of Neurohypophysial Horm., Montreal, Canada. Aug. 8-12, 1997.

North, W.G. and Du, J. Production and processing of vasopressin gene-related proteins by neuroendocrine tumors. *Proc. Soc. Neuro. Sci.* 23:63.4, 1997.

North, W.G., Fay, M.J., Longo, K. and Du, J. Vasopressin gene-related products in the management of breast cancer. DOD Breast Cancer Research Program Meeting: Era of Hope Proceedings, 2:795-796, 1997.

Fay, M., Du, J., Longo, K. and North, W. The role of vasopressin and oxytocin hormones in breast cancer. DOD Breast Cancer Research Program Meeting: Era of Hope Proceedings, 2:797-798, 1997.

Du, J. and North, W.G. Breast cancer cells express normal forms of all vasopressin receptors plus an abnormal V2R. Proc. Amer. Assoc. Cancer Res. A 1175, 1999.

Report

Vasopressin gene related products are markers of human breast cancer

William G. North, Sara Pai, Andrew Friedmann, Xiaoming Yu, Michael Fay and Vincent Memoli¹
Departments of Physiology and ¹ Pathology, Dartmouth Medical School, Lebanon, New Hampshire, 03756, USA

Key words: breast carcinoma, immunohistochemical analysis, oxytocin gene expression, tumor markers, vasopressin gene expression

Summary

Immunohistochemical analysis for products of vasopressin and oxytocin gene expression was performed on acetone-fixed tissues from 19 breast cancers representing a variety of tumor sub-types. Studies employed the avidin-biotin complex (ABC) immunohistochemical procedure and utilized rabbit polyclonal antibodies to arginine vasopressin (VP), provasopressin (ProVP), vasopressin-associated human glycopeptide (VAG), oxytocin (OT), oxytocin-associated human neurophysin (OT-HNP), and a mouse monoclonal antibody to vasopressin-associated human neurophysin (VP-HNP). Western Blot analysis was performed on protein extracts of fresh-frozen tissues from 12 additional breast tumors. While VP gene related proteins were not detected in normal breast tissue, immunohistochemistry revealed the presence of VP, ProVP, and VAG in all neoplastic cells for all of the tumor tissues examined. Vasopressin-associated human neurophysin was evident in only one of 19 acetone-fixed tumor preparations. However, Western blot analysis for all 12 fresh-frozen tumor samples showed the presence of two proteins, 42,000 and 20,000 daltons, that were immunoreactive with antibodies to VP, VP-HNP, and VAG. Oxytocin and OT-HNP, by immunohistochemistry, were found to be common to cells of normal breast tissues. For tumors, positive staining for OT was observed in 8 of 18 tumors, while OT-HNP was not detected in any of the tumors examined. These findings indicate that VP gene expression is a selective feature of all breast cancers, and that products of this expression might therefore be useful as markers for early detection of this disease and as possible targets for immunotherapy.

Introduction

Breast cancer is the leading cause of death among American women between the ages of 40 and 55 years. It has been predicted that 12% of women, during their lifetime, will be diagnosed as having this cancer, and that 3.5% will die of the disease [1]. Efforts are therefore currently under way to develop improved methods for the earlier detection of breast cancer, and more effective therapeutic interventions [2–4]. It is likely that both of these aims

could be aided by the identification of easily detectable markers of this disease. One or more vasopressin gene related products (VP, VP-HNP, VAG, and ProVP) have been shown to be effective markers for most, or all, small-cell tumors of the lung [5, 6]. Since two of these substances are released from small-cell tumors into the circulation, inappropriately high levels in the plasma of most patients can be employed to evaluate treatment, and to serve as predictors of recurrent disease [5, 7]. As well as this, VP gene expression by small-cell carcinoma of the

Address for offprints: W.G. North, Department of Physiology, Dartmouth Medical School, 1 Medical Center Drive, Lebanon, NH 03756, USA

lung (SCCL) leads to the formation of Neurophysin-Related Cell-Surface Antigen (NRSA), a component of the plasma membrane of these tumors that can be targeted in patients with antibodies to neurophysin [8, 9]. Oxytocin gene related products have also been identified in many SCCL tumors. With respect to breast cancer, OT is known to be involved in the physiology of human mammary glands, and VP has been reported to act as a growth factor for some mammary tumor cells in culture [10]. Therefore, in this study, antibodies to different VP and OT gene-related products were employed for the immunohistochemical screening of an archival library of breast tumors made available through the Department of Pathology at the Dartmouth-Hitchcock Medical Center. In addition, Western blot analysis was performed on fresh-frozen tumor samples with three of the antibody preparations.

Materials and methods

Tissue specimens

Fresh samples of breast tumor were obtained by surgical resection from patients treated at the Dartmouth-Hitchcock Medical Center. These tissue samples represented a range of tumor histological types [11]. Of the 19 tumor samples used in the study, 12 were obtained through biopsy of the breast, 5 were from mastectomies, and 2 were from metastatic sites. A tissue sample of normal human cerebral cortex, and tissue samples of normal human pituitary and hypothalamus, were obtained from autopsy, and these served as negative and positive controls for immunohistochemical staining. All of the tissues were fixed with acetone using the AMeX procedure [12], and then embedded in paraffin. Fresh-frozen tissues from 12 additional breast tumors used in Western blot analysis were obtained on dry-ice from the Cooperative Human Tissue Network, Philadelphia, PA.

Polyclonal antibodies

Rabbit polyclonal antibodies to VP, to OT, and to a synthetic C-terminal 18 amino acid residue of vasopressin-associated human glucopeptide (VAG₂₂₋₃₉) were all prepared here by employing the purified substances, coupled to thyroglobulin with glutaraldehyde, as antigens. Antibodies to VP (Gonzo 3) have been successfully employed in RIA at a dilution of 1:80,000, and in this assay showed <0.1% cross-reaction with OT and <0.1% cross-reaction with vasotocin. Hence, Gonzo 3 would seem to contain VP ring directed antibodies as dominant constituents. Antibodies to OT (Kermit 5) were effective in RIA at 1:50,000, and displayed <0.2% cross-reaction with VP and <1% cross-reaction to vasotocin. This preparation is, therefore, believed to comprise chiefly OT tail-directed antibodies. The OT-HNP antibody preparation (Archie 3) has been described previously [13], and seems to contain dominant antibodies directed against the unique N-terminal region plus one of the conserved central sequences of this protein. The first three were used in immunohistochemical studies at dilutions of from 1:200 to 1:400; VAG antibodies (Boris Y2) were used at dilutions of from 1:600 to 1:1000.

Rabbit polyclonal antibodies (YL3) that recognize the tripeptide bridge connecting VP to VP-HNP in ProVP were a generous gift from Joseph Verbalis of Pittsburgh, PA. Dr. Verbalis employed a synthetic dodecapeptide that represents the tripeptide tail of VP, the tripeptide bridge, and the first six amino acid residues of VP-HNP as antigen for raising these antibodies. These antibodies were shown [14] to uniquely react with ProVP, and not with VP or VP-HNP. In the present studies they were used at serum dilutions of from 1:200 to 1:600.

Monoclonal antibodies

A monoclonal antibody (Nab1) to VP-HNP, that was generated through hybridoma technology by one of us (WGN), was also utilized in immunohistochemical studies and Western Blot Analysis. The antibody was obtained from mouse ascites by affinity chromatography on a column of VP-HNP-Sepha-

rose [9], and used at concentrations from 0.025 to 0.05 µg/ml. This antibody showed <1% cross-reaction with OT-HNP in RIA.

Immunohistochemical staining

Tissue sections of 4 µm were examined using the avidin-biotin complex (ABC) immunohistochemical procedure (Vector Laboratories, Burlingame, CA). Following the removal of paraffin by washing in xylene (3 × 5 min) and acetone (30 sec), tissue sections were rinsed with PBS (2 × 3 min) and incubated with 1.5% goat serum (for studies with rabbit antibodies) or 1.5% horse serum (for studies with the mouse monoclonal antibody), supplied by Vector Laboratories, at ambient temperature to block non-specific binding. After removal of blocking serum by aspiration, tissues were incubated with the relevant primary antibody diluted with 10% goat serum (polyclonal antibodies), or 10% horse serum (monoclonal antibody), at 4° C for 24 hr. Primary antibody was removed by rinsing in PBS (2 × 3 min), and biotinylated secondary antibody, comprising either goat anti-rabbit IgG or horse anti-mouse IgG, applied at a concentration of 20 µg/ml for 30 min at ambient temperature. Following the removal of unbound secondary antibody with PBS (2 × 3 min), endogenous peroxidase was blocked with a methanol solution containing 3% hydrogen peroxide [15]. Tissues were then rinsed with PBS and incubated with an avidin-peroxidase complex (25 µg/ml) for 30 min at ambient temperature. Excess complex was removed with PBS (2 × 3 min), and the bound complex was visualized by the peroxidase oxidation of 3,3'-diaminobenzidine over 3 min when presented as a 0.2 mg/ml solution with 0.03% hydrogen peroxide. Counterstaining was performed with hematoxylin. Tissues were then dehydrated through increasing concentrations of ethanol to xylene and coverslipped with permount. In order to record findings with black and white photography, this counterstaining was later removed with acid-alcohol (0.8 M HCl in 95% ethanol). Lack of staining in sections incubated with normal serum instead of primary antibody preparations was used to demonstrate antibody specificity.

Western Blot analysis

Protein from finely minced tumor tissue was extracted by sonication in 100 volumes of 0.1 M HCl. Suspensions were centrifuged at 1500 × g for 10 min at ambient temperature, and soluble protein was then precipitated with 40% TCA. This protein was pelleted by centrifugation at 10,000 × g for 2 min. TCA was then removed from pellets by washing (×2) with ether. Protein was resuspended in 0.1 M Tris HCl (pH 8.7), reduced with mercaptoethanol at 100° C for 5 min (and in some cases S-alkylated with N-ethyl maleimide), and subjected to SDS-PAGE electrophoresis on 15% gels at pH 9.3 using the method of Laemeli [16]. Separated proteins were then electrophoretically transferred with 20 mM Tris glycine (pH 8.0) to Immobilon (PVDF) membranes. These membranes were blocked with a 5% non-fat milk solution, washed (1 × 15 min, 2 × 5 min) with PBS containing 0.5% Triton, and reacted with preparations of mouse monoclonal antibody to VP-HNP, with rabbit polyclonal antibodies to VP, with rabbit polyclonal antibodies to VAG, or with ubiquitous mouse or rabbit IgG (negative controls), for 1 h at ambient temperature. Following a second wash in PBS-Triton (1 × 15 min, 2 × 5 min), the membranes were treated, respectively, with goat anti-mouse IgG-horseradish peroxidase conjugate or goat anti-rabbit IgG-horseradish peroxidase conjugate for 1 h, and then washed with PBS-Triton (1 × 15 min, 4 × 5 min). Immunoreactive proteins were visualized using an ECL Western Blotting Detection System with exposure of x-ray film from 10 seconds to 5 min. Prestained SDS-PAGE standard proteins were employed as molecular size markers.

Results

Immunostaining with antibodies to VP, ProVP, and VAG

All tumor cells, for all tumor specimens examined, showed intense positive immunological staining with antibodies to VP, and to the C-terminal region of VAG. Positive immunostaining with antibodies to the bridging region of ProVP was found in 11 of 14



Fig. 1. Acetone-fixed breast carcinoma showing colloid-type inclusions. Positive staining with rabbit polyclonal antibodies to vasopressin, using the Avidin-biotin complex immunohistochemical procedure and peroxidase oxidation of 3,3' diaminobenzidine (magnification, $\times 1500$).

tumors tested. Tumor tissues represented all forms that typify breast carcinoma (Table 1). Figure 1 represents a colloid carcinoma and immunostaining obtained with antibodies to VP. Figure 2 is the immunostaining that typified the reaction of infiltrating lobular carcinoma with antibodies to VAG. No immunostaining of the normal connective and glandular tissues surrounding tumors, or with cerebral cortex, was obtained with antibodies to VP, ProVP, or VAG.

Immunostaining with antibodies to OT and VP-HNP

Some tumor tissues (8 of 18 tested), as well as surrounding normal glandular tissue, stained with polyclonal antibodies to OT. Oxytocin-associated human neurophysin was not detected in any of the 19 tumors examined. The mouse monoclonal antibody to VP-HNP failed to react with all but one of the 19 tumor specimens (an infiltrating lobular carcinoma) and gave no immunostaining of surrounding normal tissues.

Western blot analysis with antibodies to VP and VP-HNP and VAG

Both polyclonal antibodies to VP and VAG and the mouse monoclonal antibody to VP-HNP gave similar patterns of immunoreactive proteins with electrophoretograms from Western blot analysis of 12 fresh-frozen tissues of breast cancer. In each case, immunoreactive proteins were discerned with apparent molecular weights of 40,000 and 20,000 daltons. In addition to these, the antibody to VP-HNP reacted weakly with a protein of approximately 10,000 daltons. The pattern obtained for four tumor samples with the antibody to VP-HNP is represented in Fig. 3.

Discussion

The results obtained in this study indicate that the VP gene is expressed by all breast cancers, and that VP is a product common to all these tumors while being immunologically absent from surrounding normal breast tissue. This tumor VP could be per-

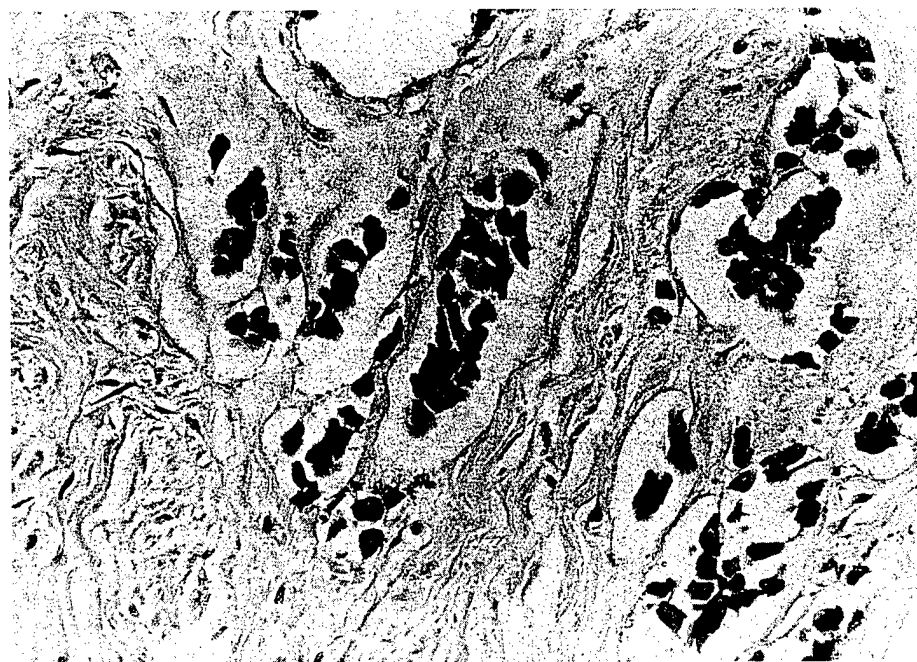

Fig. 2. Acetone-fixed breast carcinoma of the infiltrating lobular sub-type showing positive immunostaining with rabbit polyclonal antibodies to vasopressin-associated human glycopeptide. The procedure employed was avidin-biotin complex immunohistochemistry with peroxidase oxidation of 3,3' diaminobenzidine (magnification, $\times 480$).

Table 1. Presence of vasopressin and oxytocin gene related products in human breast cancer

Cancer subtype	VP gene related antigens*				OT gene related antigens*	
	VP	VAG	VPRG	ProVP	OT	OT-HNP
Infiltrating ductal	na	-	+	na	na	-
Infiltrating ductal	+	-	+	+	-	-
Infiltrating ductal	+	-	+	+	+	-
Infiltrating ductal	+	+	+	+	+	-
Infiltrating ductal	+	-	+	+	-	-
Infiltrating ductal	+	-	+	-	-	-
Infiltrating ductal	+	-	+	+	+	-
Infiltrating ductal	+	-	+	na	+	-
Infiltrating ductal	+	-	+	+	-	-
Infiltrating ductal	+	-	+	+	-	-
Infiltrating ductal	+	-	+	-	-	-
Infiltrating ductal	+	-	+	-	+	-
Colloid	+	-	+	+	-	-
Colloid	+	-	+	na	-	-
Colloid	+	-	+	+	+	-
Colloid	+	-	+	+	+	-
Infiltrating tubular	+	-	+	na	+	-
Infiltrating tubular	+	-	+	+	-	-
Infiltrating lobular	+	-	+	na	-	-
Total positive	18/18	1/19	19/19	11/14	8/18	0/19

* Positive (+) or negative (-) immunoreactivity using antibody preparations and the ABC procedure. na = not attempted.

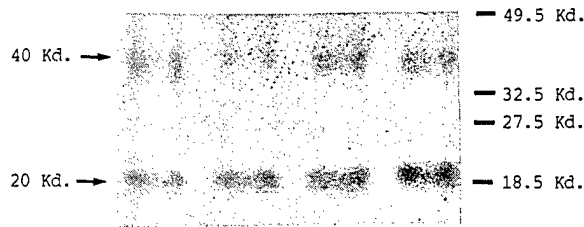

Fig. 3. Western blot analysis from SDS-PAGE (15%) showing mercaptoethanol-reduced proteins from four biopsied human breast tumors that were immunoreactive with a mouse monoclonal antibody (NAb 1) to vasopressin-associated human neurophysin. The PVDF membrane was blocked with non-fat milk as a 5% solution in PBS-Triton. Incubations with 0.5 μ g/ml primary antibody, and then with goat anti-mouse IgG-horseradish peroxidase conjugate (BRL), in 5% nonfat milk, were each performed for 1 h at room temperature. Immunoreactive proteins were visualized on x-ray film exposed to the membrane for 5 min.

forming a role as an autocrine growth factor in the same manner as it appears to do for many small-cell tumors of the lung [17]. Taylor and coworkers [10] have shown that VP may be an important growth modulator of human breast cancer, and other workers [18] have described a growth-promoting action of the peptide on rat mammary tumors in culture.

While the origin of human breast cancer is not yet clear, an increased risk is associated with atypical hyperplasia, especially of both ductal and lobular types. It is possible that some hyperplasia conditions become malignant as a consequent of an overproduction of growth factors by the affected cells. Since VP was found to be common to all of the breast tumors examined in this study, it is conceivable that this peptide is also a marker of those proliferating cells that serve as progenitors of breast cancer. Such a hypothesis is readily testable and, if true, might lead to a method for recognizing precancerous cells in patient biopsies.

Vasopressin-associated human glycopeptide was another marker immunologically identified in all of the breast cancers examined. This secretory product of hypothalamic neurons has yet to have a defined physiological function. However, VAG has been demonstrated to be a component of NRSA in SCCL, and as such is a possible target on the plasma membrane of these cells for radiodiagnostic imaging and immunotherapy [9]. If this entity, as a com-

ponent of proteins, also becomes incorporated into the plasma membranes of breast cancer cells, it would then seem to be an ideal candidate through which imaging and treatment of this disease could be carried out. In support of this possibility are the findings presented here from Western Blot analysis of VAG immunoreactivity, that demonstrate it to be associated with a larger protein(s) of the same molecular size as those found to occur in SCCL [8]. These are proteins of 40,000 and 20,000 daltons that also react with antibodies to VP and VP-HNP. Nevertheless, differences between the products of breast cancer cells and small-cell tumors are indicated by the failure of our monoclonal antibody to VP-HNP to positively stain all but one of the breast cancer specimens, even though this antibody reacted with breast cancer proteins in Western blot preparations. This suggests there might be even more conformational abnormalities in breast cancer-produced neurophysin structures than occur in small-cell carcinoma, and this in turn, might reflect more significant substitutions and/or omissions in the exon B and exon C regions of the expressed VP gene of breast cancer cells. Staining of similar intensity with VP antibodies and antibodies to the peptide bridging region of ProVP for most tumors makes it less likely that significant abnormalities are present in the exon A region of the VP gene(s) expressed by breast cancer cells [19].

Oxytocin, in contrast to VP gene related products, appeared to be common to both normal breast tissue and some tumor cells. Staining for OT was evident in 2 of 4 tumors of the colloid sub-type, in 5 of 12 ductal tumors, and in 1 out of 2 of the tubular sub-type, but was not evident in the one lobular tumor examined. The data indicated that overall, the OT gene is expressed in about 44% of breast carcinomas, although there is evidence that gene expression may be abnormal because none of the tumors appeared to contain a structure immunologically identified as OT-HNP.

Hence, only VP gene expression would seem to be a universal feature of breast carcinoma. While there is evidence that this VP gene gives rise to abnormal protein products, these products are always recognized in immunological studies by antibodies to VP and VAG. These substances, would therefore

appear to represent important markers of this disease and, as such, could be effectively utilized in its diagnosis and treatment.

Acknowledgement

This work was supported in part by PHS awards CA 19613 and CA 46551. Michael Fay was a postdoctoral fellow on NIH Training Grant T32 DK 07508. Excellent technical assistance was provided by Susan Gagnon and Maudine Waterman.

References

1. Colditz GA: Epidemiology of breast cancer. *Cancer* 71: 1480-1489, 1993
2. Strax P: Detection of breast cancer. *Cancer* 66: 1336-1340, 1990
3. Lippman ME: The development of biological therapies for breast cancer. *Science* 259: 631-632, 1993
4. Kellen JA, Wong A, Georges E, Ling V: R-verapamil decreases anti-estrogen resistance in a breast cancer model. *Anticancer Research* 11: 809-812, 1991
5. North WG: Neuropeptide production by small cell carcinoma: vasopressin and oxytocin as plasma markers of disease. *J Clin Endocrinol Metab* 73: 1316-1320, 1991
6. Friedmann AS, Malott KA, Memoli VA, Pai SI, Yu XM, North WG: Products of vasopressin gene expression in small-cell carcinoma of the lung. *Br J Cancer* 69: 260-263, 1993
7. North WG, Maurer LH, Valtin H, O'Donnell J: Human neurophysins as potential tumor markers for small cell carcinoma of the lung: application of specific radioimmunoassays. *J Clin Endocrinol Metab* 51: 892-896, 1980
8. North WG, Yu X-M: Vasopressin mRNA and neurophysin-related cell-surface antigen (NRSA) of small-cell carcinoma. *Peptides* 14: 303-307, 1993
9. North WG, Hirsh V, Lisbona R, Schulz J, Cooper B: Imaging of small cell carcinoma using ¹³¹I-labelled antibodies to vasopressin associated human neurophysin (VP-HNP). *Nuclear Med Comm* 10: 643-651, 1989
10. Taylor AH, Ang VTY, Jenkins JS, Silverlight JJ, Coombes RC, Luqmani YA: Interaction of vasopressin and oxytocin with human breast cancer cells. *Cancer Res* 50: 7882-7886, 1990
11. Robbins SL, Kumar V: *Basic Pathology*. W B Saunders Co, Philadelphia, 1987, pp 657-670
12. Sato Y, Mukai K, Watanabe S, Goto M, Shimosato Y: The AMeX Method. *A J Pathol* 125: 431-435, 1986
13. North WG, LaRochelle FT Jr, Melton J, Mills R: Isolation and partial characterization of two human neurophysins: Their use in the development of specific radioimmunoassays. *J Clin Endocrinol Metab* 51: 884-891, 1980
14. Rosenbaum L, Neuwelt E, Van Tol H, Loh P, Verbalis J, Hellstrom I, Hellstrom K, Nilaver G: Expression of neurophysin-related precursor in cell membranes of small-cell carcinoma. *Proc Natl Acad Sci* 87: 9928-9932, 1990
15. Streefkerk JG: Erythrocyte pseudoperoxidase activity by treatment with hydrogen peroxide following methanol. *J Histochem Cytochem* 20: 829-831, 1972
16. Laemeli UK: Cleavage of structural proteins during the assembly of the head of bacteriophage T4. *Nature* 227: 680-685, 1970
17. Sethi T, Langdon S, Smyth J, Rozengurt E: Growth of small cell lung cancer cells: Stimulation by multiple neuropeptides and inhibition by broad spectrum antagonists *in vitro* and *in vivo*. *Cancer Res* 52: 2737s-2742s, 1992
18. Monaco ME, Kidwell WR, Lippman ME: Neurohypophysial-hormone-responsive cell line derived from a dimethylbenzanthracene-induced rat mammary tumour. *Biochem J* 188: 437-441, 1980
19. North WG, Friedmann AS, Yu X-M: Tumor biosynthesis of vasopressin and oxytocin. In: North WG, Moses A, Share L (eds) *The Neurohypophysis: A Window on Brain Function*. Ann NY Acad Sci, New York, 1993, pp 107-121



Ionic Signals in T47D Human Breast Cancer Cells

John D. Gallagher,[†] Michael J. Fay,[‡]
William G. North,[‡] and Frances V. McCann^{‡*}

DEPARTMENTS OF ANESTHESIOLOGY[†] AND PHYSIOLOGY[‡],
DARTMOUTH MEDICAL SCHOOL, LEBANON, NEW HAMPSHIRE 03756

ABSTRACT. Increasing evidence that ion channels play a key role in the modulation of cellular mitogenesis led us to investigate the membranes of T47D human breast cancer cells to identify the ion currents present. We report here the results of voltage-clamp studies in the whole-cell configuration on isolated, non-synchronized single cells obtained from a ductal breast carcinoma. In these studies we identified an outward rectifying potassium current and a chloride current. The potassium current activated at potentials more positive than -40 mV, reached an average value of 1.4 nA, and did not inactivate with time. This current was sensitive to block by extracellular tetraethylammonium chloride (TEA, $IC_{50} = 1$ μ M), was insensitive to charybdotoxin (CTX, $IC_{50} = 7.8$ μ M), and was not diminished by repetitive pulses separated by 1 s. Rapid voltage-dependent inactivation of the current was demonstrated by tail current analysis. The current appeared calcium-insensitive. Application of hyperpolarizing pulses did not elicit an inward potassium rectifier current. Treatment with tetrodotoxin did not reveal the presence of an inward sodium current. The potassium current was increased by the presence of aspartate in place of chloride and in the presence of the chloride channel blocker 4,4'-diisothiocyanostilbene-2,2'-disulfonic acid (DIDS). We conclude that currents present in T47D breast cancer cells include a chloride current and a voltage-gated potassium outward rectifier. We suggest that the potassium current, either alone or in conjunction with potassium currents reported in different human breast cancer cell lines by others, may play a role in the modulation of the cell cycle. *CELL SIGNAL* 8;4:279-284, 1996.

KEY WORDS. Ion channels, Breast cancer, Potassium currents, Mitogenic signals

INTRODUCTION

An increasing body of evidence supports the hypothesis that potassium currents signal cellular proliferation [1]. Small-cell lung carcinoma cells (SCCL) treated with the K^+ -channel antagonist 4-aminopyridine (4-AP) demonstrate an attenuated outward K^+ current coincident with a decrease in cell proliferation [2]. In MCF-7 breast cancer cells the potassium channel antagonists quinidine, glibenclamide, and linogiride inhibit cell proliferation and cause the accumulation of cells in the G_0/G_1 phase of the cell cycle [3]. This effect on MCF-7 cells was attributed to the putative activity of adenosine triphosphate (ATP)-sensitive potassium channels. This cell line, established from pleural fluid of a patient with adenocarcinoma, retains certain characteristics of differentiated epithelium, including the presence of estrogen receptors [4]. A calcium-activated potassium current has been identified in MCF-7 cells [5] that, although correlated with cell proliferation, was not considered obligatory for growth [6].

The T47D breast cancer cell line selected for this study, originally established from the pleural effusion of a patient with infiltrating ductal carcinoma [7], also displays characteristics of an epithelial origin. These cells possess receptors for estrogen [8, 9], progesterone [6, 10-12], calcitonin [13], and vitamin D [14, 15]. We selected this cell line for investigation because estrogen-resistant clones have been produced, and we aim to develop this line as a model for evaluating breast cancer progression [16-18]. In view of the previous studies that have linked ion channels with mitogenesis, we initiated this study to identify the whole-cell currents present in unsynchronized cells of the T47D human breast cancer cell line.

MATERIALS AND METHODS

Cell Culture

The T47D human breast ductal carcinoma cell line was obtained from the American Type Culture Collection (ATCC HTB 133, Rockville, MD), and maintained in RPMI 1640 medium (Sigma, St. Louis, MO) supplemented with 0.2 IU bovine insulin/ml (Sigma, St. Louis, MO) and 10%

*Author to whom correspondence should be addressed.
Received 10 October 1995; and accepted 8 November 1995.

fetal bovine serum (FBS; Hyclone Labs, Logan, UT). Cells received fresh growth medium or were subcultured (1:3 using 0.25% trypsin + 0.02% ethylenediamine tetraacetic acid [EDTA]) every 2–3 d.

Cell Preparation

Cells were plated onto glass coverslips approximately 18 h before patch-clamp studies were initiated. Each coverslip was placed in a chamber of 0.2 mL volume and washed with extracellular physiological solution. The chamber was placed on the stage of an inverted Nikon microscope and viewed with Hoffman optics ($\times 640$). Electrode preparation and other experimental details have been presented previously [19–21].

Solutions

The physiological external bath solution for recording whole-cell currents contained the following (in mM): 140 NaCl, 4.5 KCl, 2.0 CaCl₂, 1.0 MgCl₂, and 10 4-(2-hydroxyethyl)-1-piperazine-N'-2-ethanesulfonic acid (HEPES), pH balanced to 7.3 with NaOH. The pipette solution contained (in mM) 140 KCl, 1.1 ethylene glycol-bis-(β -aminoethyl ether)-N,N,N',N'-tetraacetic acid (EGTA), 0.1 CaCl₂, 2.0 MgCl₂, and 10 HEPES, pH balanced to 7.3 with KOH. [Ionized Ca²⁺] = 10⁻⁸ M. All experiments were done at room temperature (22°C). Extracellular KCl was increased by substituting KCl for NaCl in the bath solution. Extracellular Cl was reduced by substituting potassium aspartate for KCl in the bath. Intracellular [Ca²⁺] was increased by changing pipette solution CaCl₂ to 1.08 mM [free Ca²⁺] = 4 \times 10⁻⁶ M.

Blocking Agents

Tetraethylammonium chloride (TEA; Sigma) was dissolved in extracellular solution and added in different concentrations directly to the bath. Charybdotoxin (CTX) from *Leiurus* venom was obtained from Alomone Labs (Jerusalem, Israel). The CTX was dissolved in 0.1% BSA, 100 mM NaCl, 10 mM Tris (pH 7.5) and 1 mM EDTA. This solution required the addition of 0.01% bovine serum albumin (BSA) to the bath. Because the bath total volume was 0.2 mL, replacement of the bath required only two drops of fluid. Replacement of the bath effected rapid and complete mixing of experimental solutions, as demonstrated by addition of a water-soluble dye. 4,4'-Diisothiocyanostilbene-2,2'-disulfonic acid (DIDS), a recognized Cl⁻-channel blocking agent, was added to the bath.

Data Acquisition and Analysis

Currents in the individual cells were measured by rupturing the cell membrane in the lumen of the patch electrode by suction. Patch-clamp data were obtained with a List-EPC 7 clamp circuit (Medical Systems, Greenvale, NY). Experimental protocols, details of which are presented in the figure legends, were written for PCLAMP software (Axon Instru-

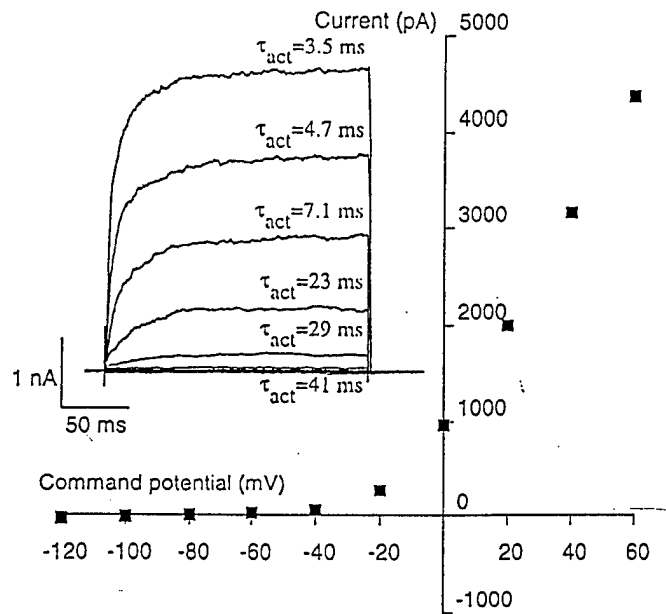

FIGURE 1. Outward rectifying K⁺ current in T47D breast cancer cells. Current vs. voltage curve showing peak outward currents recorded in a cell held at -80 mV and then stepped to voltages from -120 mV to +60 mV. Inset: Currents recorded from this cell. Note the lack of time-dependent inactivation. The time constant for activation (τ_{act}) was best described by a single exponential for voltage steps to -40, -20, and 0 mV, and by a double exponential at more positive depolarizations. The fast time constant is shown for each trace.

ments, Burlingame, CA). Data were digitized at 5 KHz and recorded with a 486 PC computer after filtering with an 8 pole Bessel filter at 1 KHz. Series resistance correction, capacity compensation, and leakage subtraction were done. All data are reported as mean \pm S.E.M.

RESULTS

Patch-clamp recordings and analyses of T47D human breast cancer cells revealed the presence of a voltage-sensitive current. This current was identified as a voltage-gated, time-independent, TEA-sensitive, charybdotoxin-insensitive, outwardly rectifying potassium current, and was present in 71 of 79 cells studied. We found no evidence of an inward rectifying potassium current or of a sodium current.

Voltage-gated Potassium Current

After rupture of the cell membrane by suction, voltage steps were applied to the cell in a normal physiological ionic gradient from a holding potential of -80 mV to command potentials of -120 mV to 60 mV. The large outward currents elicited are shown in the inset of Figure 1. The current was activated at -39.7 ± 2.2 mV ($n = 10$) and showed no time-dependent inactivation. At +40 mV depolarizations, the current reached a peak value of $1,376 \pm 231$ pA ($n = 20$). The time constants for activation could be represented by a single exponential at more negative voltage levels and

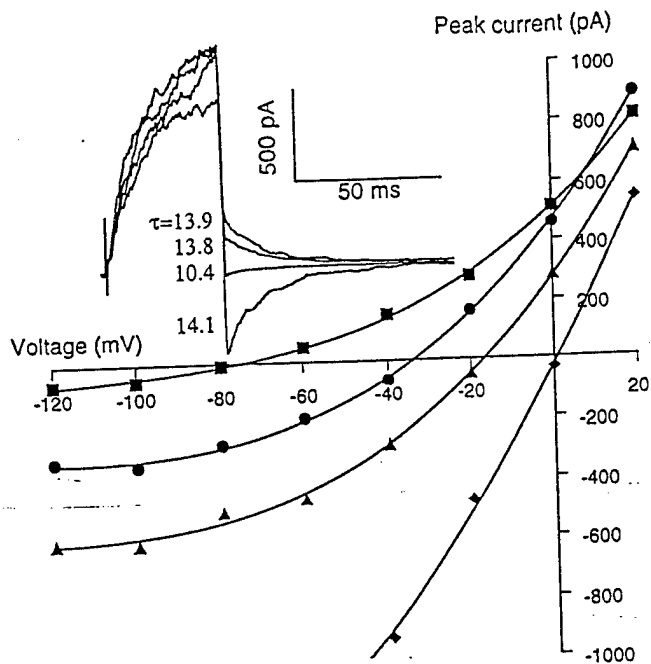

FIGURE 2. Tail currents. Peak current vs. voltage curves for tail currents recorded after a step depolarization from -80 mV to $+40$ mV. Pipette KCl concentration = 140 mM. External KCl concentration = 4.5 mM (squares), 38 mM (circles), 72 mM (triangles), or 140 mM (diamonds). Inset: Tail currents recorded at -20 mV in each external KCl concentration, with single exponential time constants (ms).

by a double exponential at more positive depolarizations. The fast time constants for activation are indicated for each current trace.

Tail Current Analyses

The outward current was activated by a voltage step from a holding potential of -80 mV to $+40$ mV. V_m was then stepped to voltages between $+20$ and -120 mV and tail currents were recorded as shown in Figure 2. Rapid voltage-dependent inactivation was observed. Changing bath KCl concentration produced changes in reversal potential for the outward current. In external KCl concentrations of 4.5 , 38 , 72 , and 140 mM, E_{rev} was -84.5 ± 1.2 mV, -31.8 ± 1.7 mV, -17.6 ± 0.2 mV, and -2.6 ± 2.2 mV, respectively ($n = 7$). For these KCl concentrations, calculated E_{rev} for a K^+ -selective current was -86.6 mV, -32.8 mV, -16.7 mV, and 0 mV, respectively. Thus, this current appears to be carried by K^+ ions. The rapid voltage-dependent recovery of the current is emphasized by the absence of use-dependent peak amplitude reduction when cells were repetitively depolarized at intervals of 1 s ($n = 8$).

Voltage Ramps

After holding the membrane potential at -80 mV, voltage ramps were applied to the cell membranes from -120 mV to $+40$ mV, with the resulting I vs. V graphs shown in

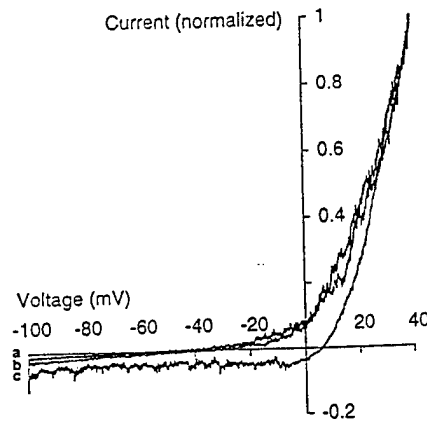

FIGURE 3. Voltage ramps in T47D breast cancer cells. From a holding potential of -80 mV, voltage ramps from -100 to $+40$ mV are shown. Curve a shows standard solutions. In curve b, pipette Ca^{2+} concentration was increased. The similarity between curves a and b suggests that no calcium-activated currents were present. Increasing external KCl concentration to 140 mM (c) alters the current vs. voltage relationships as expected. No evidence of an inwardly rectifying K current is seen, although the increase in leakage current suggests the presence of other non-voltage-activated currents.

Figure 3. These experiments were performed with standard pipette and bath solutions, and also after increasing pipette Ca^{2+} concentrations to levels as high as 4×10^{-6} and external KCl concentrations to 140 mM. In no case was a calcium-activated or inwardly rectifying current detected. However, the increased leakage current noted in symmetrical KCl solutions suggests the presence of additional K^+ currents, perhaps a ligand-modulated current or the ATP-sensitive current reported by Woodfork *et al.* [3].

TEA

Figure 4 illustrates the results of 5 experiments in which voltage steps from -80 mV (holding) to $+20$ mV were applied in the presence of increasing concentrations of TEA chloride. Exponential curve fitting allowed calculation of a 50% inhibitory concentration (IC_{50}) of $1 \mu M$ TEA chloride, indicating a marked sensitivity of the current to this substance.

CTX

Charybdotoxin, a toxic component isolated from the venom of the scorpion *Leiurus*, has been shown in a number of studies to selectively block calcium-activated K^+ channels and to have a strong blocking action on other types of K^+ channels. Results of 5 experiments in which cells were depolarized after exposure to CTX are shown in Figure 5. Calculated IC_{50} was $7.8 \mu M$, demonstrating an insensitivity of the current to the blocking effects of CTX. Both the solvent and BSA were tested in the absence of CTX and were found to have no effect on currents. The solution containing CTX completely replaced the bath in order to assure complete mixing.

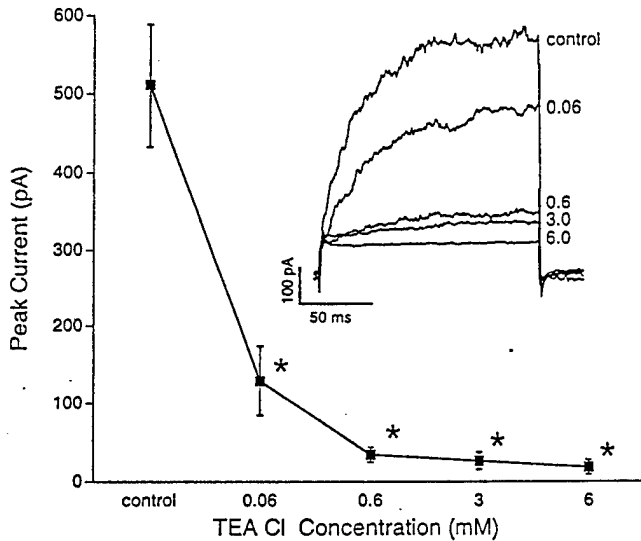

FIGURE 4. Effects of TEA chloride. Dose-related reduction in peak current following exposure to TEA chloride is demonstrated. Inset: Typical current recordings of a step depolarization from -80 mV to $+20$ mV after exposure to increasing TEA Cl concentrations. * $P < 0.0001$ vs. control by one-way ANOVA for repeated measures and Tukey's Honestly Significant Different Test.

Inward Currents

SODIUM. To determine whether a sodium inward current was present, we added TTX (3×10^{-8} M) to the bath solution. The membrane was subjected to a more negative holding potential to remove any inactivation that might be present, and the membrane was then depolarized by step pulses. No effect on the whole-cell current was detected, leading us to conclude that a voltage-gated sodium current is not present.

POTASSIUM. Experiments were designed to test for the presence of an inward potassium rectifier. The membrane

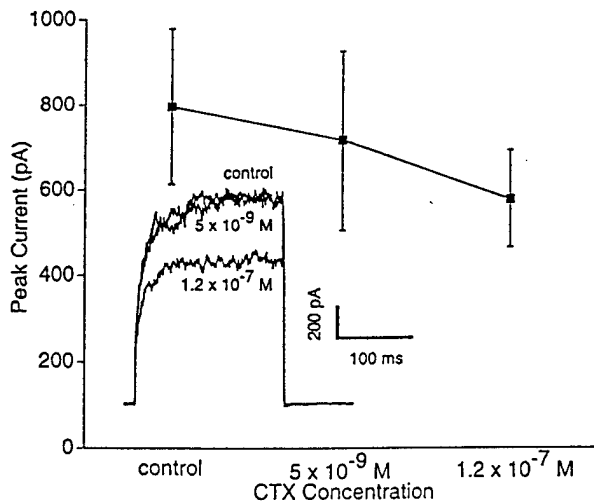

FIGURE 5. Effects of CTX. Increasing concentrations of CTX produce minimal decreases in peak outward current following a depolarization of -80 mV to $+20$ mV ($P = 0.11$). Inset: Typical current recordings after exposure to each concentration of CTX.

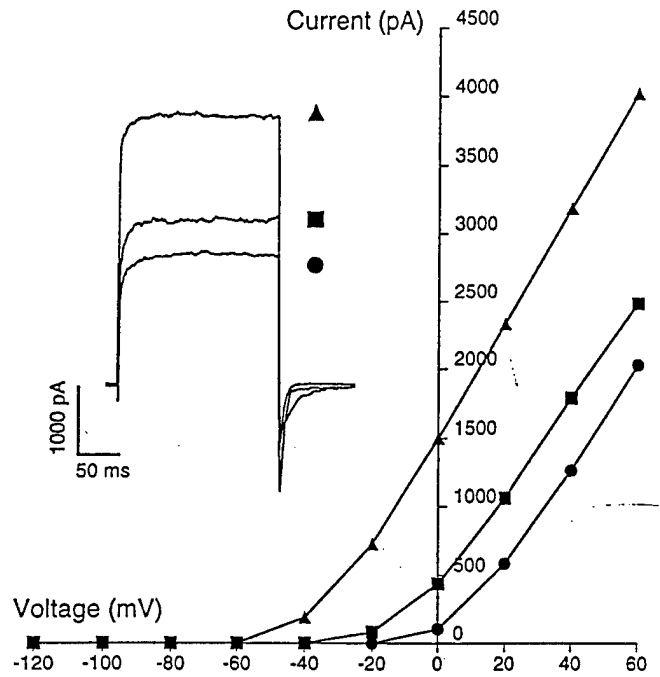

FIGURE 6. Augmentation of outward current by aspartate. From a holding potential of -80 mV, voltage steps from -120 to 60 mV were applied. The inset displays currents recorded after voltage steps to 60 mV in physiological bath solution (square), symmetrical 140 mM KCl solution (circle), and after substitution of 140 mM K aspartate for KCl (triangle). Current-voltage relationships for the same experiments demonstrate a marked increase in outward current after aspartate substitution.

was stepped to various hyperpolarized potentials in physiological, reversed, and altered extracellular potassium concentrations. There were no currents detected under these conditions.

CALCIUM. Increased amounts of calcium delivered both to the pipette and to the bath did not effect any changes in the outward current. With potassium replaced by CsCl in the pipette and with TEA in the bath, increased calcium in and out and addition of BaCl_2 (20 mM) did not reveal any inward current. Addition of CTX did not change the magnitude or time course of the potassium current. We conclude that calcium does not affect this voltage-gated potassium current.

CHLORIDE. The substitution of aspartate for chloride in the bath solution greatly enhanced the potassium current, as shown in Figure 6. The membrane potential was held at -80 mV, after which depolarizing steps were delivered from -120 mV to 60 mV. The marked increase in the total outward current is shown in the current traces and in the I vs. V relationship.

Chloride substitution experiments, tested by tail-current analyses, gave further evidence of the chloride component of the total current, as shown in Figure 7A-D. The cell membrane was held at -80 mV and then depolarized to 40 mV. Tail currents were then measured as the membrane

Ion Currents in Breast Cancer

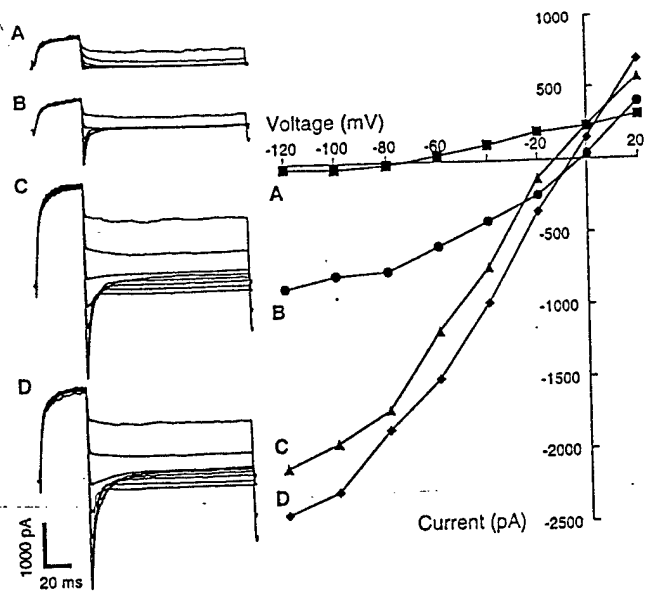

FIGURE 7. (A-D) Effects of chloride substitution on tail currents. Current traces A, B, C, and D display tail currents recorded after a depolarization to 40 mV from a holding potential of -80 mV. Shown are tail currents produced by voltage steps from 20 to -120 mV. The current-voltage curves for these traces are shown at the right. The pipette contained 140 mM KCl. Panel A was recorded in physiological bath solution. Panel B was recorded in symmetrical KCl solution and demonstrates a reversal potential near 0 mV. In C, 140 mM K aspartate was substituted for KCl in the bath solution and a change in reversal potential occurs. In D, 70 mM KCl with 70 mM K aspartate produced an intermediate change in reversal potential.

was stepped from 20 to -120 mV in a normal physiological gradient (Fig. 7A). The potassium content of the bathing solution was then elevated so that the potassium gradient was symmetrical (Fig. 7B). Under this condition, the reversal potential was near 0 mV, (I vs. V graph), as one would predict for a potassium current. The reversal potential was then observed to shift as K^+ aspartate was substituted for KCl (Fig. 7C). The reversal potential again shifted along the voltage axis as the bath was changed to contain 70 mM KCl and 70 mM K aspartate (Fig. 7D).

An increase in the outward current was also measured when the chloride channel blocker DIDS was added to the bath. Application of a continuous ramp of increasing voltage (-140 to 40 mV) from a holding voltage of -80 mV resulted in an increase in the outward current from 1,042 pA to 1,265 pA, as shown in Figure 8. We conclude from these data that a chloride current is present in these cells.

DISCUSSION

The voltage-gated potassium current we have characterized in T47D breast cancer cells activates rapidly at a membrane voltage of -40 mV, is outwardly rectifying, and displays no time-dependent inactivation. Peak currents are very large and at a depolarization level of 40 mV (holding: -80 mV), reached levels of 1.4 nA. This current is sensitive to block

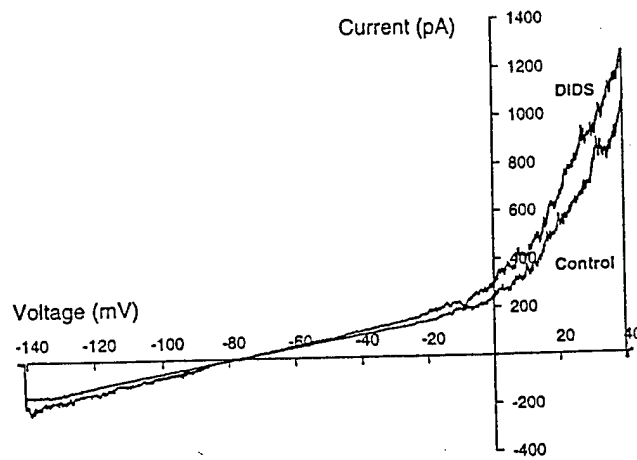

FIGURE 8. Increase in outward current after addition of DIDS. From a holding potential of -80 mV, a continuous ramp of increasing voltage from -140 mV to 40 mV was applied. The pipette contained 140 mM KCl. During the control recording, the bath contained standard physiological solution. After the addition of DIDS 4×10^{-4} M to the bath, peak current increased from 1,042 pA to 1,265 pA. This suggests that DIDS blocked an inward Cl^- current.

by TEA but not to CTX. TEA is a widely documented blocker of a potassium channels, but CTX is now known to block other potassium channels as well as the calcium-activated potassium channels [22]. In some cells, CTX blocks even the voltage-gated maxi-K channel [23]. In the experiments reported here, increased levels of internal calcium did not effect any change in either the magnitude of the potassium current or in the reversal potential, results that indicate that a calcium-activated potassium current is either not present or is of such relative magnitude compared to the outward rectifier that it is not readily visible by the whole-cell technique. In experiments in which the membrane holding potential was increased to hyperpolarized levels of -140 mV, no evidence of an inward rectifier was seen. The reversal potentials measured in a range of transmembrane potassium concentrations compared with the calculated values provide clear evidence for the ionic identity of the charge carrier. This current was not changed in the presence of tetrodotoxin, an observation that supports our conclusion that a sodium current is not present.

This report documents the first recordings of electrical activity from the T47D cell line of human breast cancer, an epithelial-like cell line obtained from an infiltrating ductal carcinoma of the breast. Another epithelial-like cell line of human breast cancer (MCF-7), obtained from an adenocarcinoma, has been explored by Woodfork *et al.* [3]. They concluded, from experiments using known potassium blockers on cell proliferation, that a ligand-activated potassium channel (i.e., an ATP-sensitive channel) is most likely involved in the proliferation of MCF-7 cells. In a preliminary report of voltage-clamp experiments [24], three types of current/voltage relations were described in MCF-7 cancer cells. In the presence of Mg-UDP (uridine diphosphate to enhance activation of K_{ATP}) in the pipette, linear I vs. V relationships

showed reversal potentials of -62 mV and -7 mV, respectively, while a third current was outwardly rectifying and reversed at -23 mV. Only the third type was observed when 2 mM ATP was also added to the pipette. The only current reported that appears similar to the outward rectifier we describe in T47D cells is a linear current with a reversal potential of -62 mV. The major potassium current in these two cell lines seems to be remarkably different. While we have not yet specifically studied the effects of ATP, we did note an increased leakage current in symmetrical potassium, which suggests the presence of an additional component.

Evidence is presented here for the presence in T47D cells of a chloride channel. The data include enhancement of the outward current by aspartate substitution for chloride, enhancement of the outward current in the presence of the chloride blocking agent DIDS, and the shift of the reversal potential in the presence of altered chloride concentrations in the bath. These data are consistent with the criteria for the identification of a chloride current.

In view of the complex nature and behavior of breast cancer cells, it is not difficult to appreciate that chloride ions may function in multiple roles (e.g., membrane stabilization, regulation of intracellular pH, modulation of secretion, and cell volume control). These cells exhibit prolific secretory behavior. Another possibility to be considered in regard to this chloride current is that the aspartate itself may unmask a different potassium component, since a variety of amino acids are known to exert excitatory effects on cells that have receptors for these agents [25]. Further studies should help to characterize and identify this component of the whole-cell currents.

Whether the apparent differences in the currents measured in the MCF7 and T47D cell lines are related to some basic property of these two types of cells or to variations in the stage of the cell cycle may be resolved in future studies using cell-cycle-synchronized cultures. Based on previous studies with other cell types [1], we suggest that it is more likely that the potassium current will be involved in modulation of the cell cycle while the chloride channel will be linked to secretion, regulation of cell volume, or some other cellular function.

Supported in part by the Norris Cotton Cancer Center, the NCI core grant of the NCCC (CA 23108), and by Department of Defense grants DAMD 17-94-J-4131 (M.J.F.) and DAMD 17-94-J-4288 (W.G.N.).

References

- Dubois J. M. and Rouzair-Dubois B. (1993) *Prog. Biophys. Mol. Biol.* 59, 1-21.
- Pancrazio J. J., Tabbara I. M. and Kim Y. I. (1993) *Anticancer Res.* 13, 1231-1234.
- Woodfork K. A., Wonderlin W. F., Peterson V. A. and Strobel J. A. (1995) *J. Cell. Physiol.* 162, 163-171.
- Soule H. D., Vasquez A., Albert S. and Brennan M. (1973) *J. Natl. Cancer Inst.* 51, 1409-1416.
- Enomoto K., Cossu M. F., Maeno T., Edwards C. and Oka T. (1986) *FEBS Lett.* 203, 181-184.
- Wegman E. A., Young J. A. and Cook D. I. (1991) *Pflügers Arch.* 417, 562-570.
- Keydar I., Chen I., Karby S., Weiss F. R., Delaea J., Radu M., Chaitcik S. and Brenner H. J. (1979) *Eur. J. Cancer* 15, 659-670.
- Horwitz K. B., Zava D. T., Thilagar A. K., Jensen E. M. and McGuie W. L. (1978) *Cancer Res.* 38, 2434-2437.
- Chalbos D., Vignon F., Keyar I. and Rochefort H. (1982) *J. Clin. Endocrinol. Metab.* 55, 276-283.
- Horwitz K. B., Mockus M. B. and Lessey B. A. (1982) *Cell* 28, 633-642.
- Wei L. L. and Miner R. (1994) *Cancer Res.* 54, 340-343.
- Sartorius C. A., Groshong S. D., Miller L. A., Powell R. L., Tung L., Takimoto G. S. and Horwitz K. B. (1994) *Cancer Res.* 54, 3868-3877.
- Lamp S. J., Findlay D. M., Moseley J. M. and Martin T. J. (1981) *J. Biol. Chem.* 256, 12269-12274.
- Freake H. C., Marcocci C., Iwasaki J. and McIntyre I. (1981) *Biochem. Biophys. Res. Commun.* 101, 1131-1138.
- Sher E., Eisman J. A., Moseley and Martin J. T. (1981) *Biochem. J.* 200, 315-320.
- Reddel R. R., Alexander I. E., Koga M., Shine J. and Sutherland R. L. (1981) *Cancer Res.* 48, 4340-4347.
- Graham M. L., Krett N. L., Miller L. A., Leslie K. K., Gordon D. F., Wood W. M., Wei L. L. and Horwitz K. B. (1981) *Cancer Res.* 50, 6208-6217.
- Zhang Q., Borg A. and Fuqua W. (1993) *Cancer Res.* 53, 5882-5884.
- McCann F. V., McCarthy D. C. and Noelle R. J. (1991) *Cell Signal.* 3, 483-490.
- McCann F. V., McCarthy D. C., Gallagher J. D. and Noelle R. J. (1993) *Cell Signal.* 5, 417-424.
- Gallagher J. D., Noelle R. J. and McCann F. V. (1995) *Cell Signal.* 7, 31-38.
- Garcia M. L., Knaus H.-G., Munujos P., Slaughter R. S. and Kaczorowski J. (1995) *Am. J. Physiol.* 269 (Cell Physiol. 38): C1-C10.
- Snetkov V. A., Hirst S. J., Twort C. H. C. and Ward J. P. (1995) *Br. J. Pharm.* 115, 1117-1125.
- Klimatcheva E. and Wonderlin W. (1995) *Endocrine Soc. Abstr.* P2-642:451.
- Takeuchi A. (1987) *Jpn. J. Physiol.* 37, 559-572.

Immunohistochemical evaluation of vasopressin gene expression in fibrocystic breast disease.

Michael J. Fay¹, Rennie S. Mathew¹, Edward M. Donnelly¹, Vincent A. Memoli², and William G. North^{1,3}

Departments of Physiology¹ and Pathology², Dartmouth Medical School, Lebanon, NH 03756-0001

Summary: We previously found that expression of the vasopressin gene is a common feature of human breast cancer. In the present study we examined 17 different cases of benign fibrocystic breast disease for vasopressin expression using immunohistochemistry and antibodies directed against vasopressin and vasopressin-associated glycopeptide. All cases examined were negative for vasopressin gene expression using these antibodies. These results suggest that vasopressin gene expression occurs as part of the carcinogenic process rather than being a marker of cellular proliferation in the breast.

Key Words: Vasopressin, fibrocystic breast disease, immunohistochemistry

Running Title: Vasopressin and fibrocystic breast disease

³ Correspondence should be addressed to William G. North, Dartmouth Medical School, Department of Physiology, 752E Borwell, 1 Medical Center Drive, Lebanon, NH 03756-0001, Telephone: (603)650-7736, Fax: (603)650-6130

Introduction

Although a number of risk factors have been identified as possible causative agents for breast cancer, the etiological origin of this disease remains obscure (Henderson, 1993). Among those conditions which are predisposing towards breast cancer are proliferative breast disease, particularly atypical ductal and lobular hyperplasia (Dupont and Page, 1985; London et al., 1992; Connolly and Schnitt, 1993; Dupont et al., 1993). Atypical hyperplasia is classified as a borderline lesion because it has some of the histological features of carcinoma *in situ*. Previously we found that expression of the vasopressin gene is a common feature of human breast cancer using immunocytochemistry and antibodies directed against different regions of the vasopressin precursor (North et al., 1995). These results lead to the possibility that vasopressin expression could either, be a marker of cellular proliferation, represent part of the oncogenic process, or be a recognizable feature of cancer progenitor cells in precancerous breast lesions. We have commenced efforts to examine these questions by performing an immunohistochemical evaluation for vasopressin gene-expression using archival material representing various fibrocystic breast lesions.

Materials and Methods

Tissues

Formalin-fixed biopsy specimens were obtained from 17 patients with various forms of benign breast disease who were examined between 1975 - 1984 at Dartmouth Hitchcock Medical Center (DHMC, Lebanon, NH). The cases included, 4

cases of fibrocystic disease without hyperplasia, 9 cases of fibrocystic disease with ductal or lobular hyperplasia, and 4 cases of fibrocystic disease with atypical ductal hyperplasia. Diagnosis from pathology reports was confirmed by examining hematoxylin- and eosin- stained sections. These cases were followed for the subsequent development of breast cancer. Formalin-fixed specimens of human hypothalamus and pituitary were obtained from autopsies performed at DHMC.

Antibodies

Rabbit polyclonal antibodies directed against vasopressin and the 18 amino acid C-terminal vasopressin-associated glycopeptide were prepared using previously published methods (North et al., 1991; Friedmann et al., 1994). Antibody purification involved ammonium sulfate precipitation of the immunoglobulin fraction, and fractionation on a column of protein A Sepharose with pH gradient elution (pH 7.6 - pH 3.0). Antibodies were obtained as a pH 4.0 subfraction, dialyzed and lyophilized. Based on dilution trials, antibodies to vasopressin and vasopressin-associated glycopeptide were used at concentrations of 11 ng/ml (1:2,000) and 190 ng/ml (1:800), respectively. Protein concentrations were determined using differential spectroscopy (Waddell, 1956).

Immunohistochemistry

Sections of 4 - 6 microns from each specimen of fibrocystic breast disease were deparaffinised and stained for vasopressin and vasopressin-associated glycopeptide using the Vectastain Elite kit (Vector Laboratories, Burlingame, CA,

USA) and avidin-biotin complex (ABC) immunohistochemistry (Guesdon et al., 1979). Tissues were rehydrated by washing with xylene, descending concentrations of ethanol, and PBS (2 x 3 min, ambient temperature). Slides were blocked with 10% normal goat serum in PBS for 20 min at ambient temperature. The blocking solution was aspirated and sections incubated overnight at 4 °C with primary antibody diluted in PBS with 1.5% goat serum. Following incubation with primary antibody the slides were washed with PBS (2 x 3 min). Goat anti-rabbit biotinylated secondary antibody diluted in PBS containing 1.5% goat serum was applied at a concentration of 20 µg/ml for 30 min. Unbound secondary antibody was removed by washing 2 x 3 min with PBS, and endogenous peroxidase activity blocked using 3% hydrogen peroxide dissolved in absolute methanol (Streefkerk, 1972). After washing with PBS (3 x 5 min), slides were incubated with the avidin-peroxidase complex (25 µg/ml) for 30 min at ambient temperature. Slides were washed with PBS (2 x 3 min), and visualization of bound complex was achieved by adding a solution of 3,3'diaminobenzidine (0.2 mg/ml in PBS with 0.03% hydrogen peroxide) for 2 - 5 min. Tissues were then counterstained with hematoxylin, dehydrated in ascending concentrations of ethanol, washed in xylene, and coverslipped using permount. Antibody specificity was insured by incubating negative controls with pre-immune rabbit serum fractionated, using protein A Sepharose, at pH 4.0.

Results

Positive immunohistochemical staining was obtained for vasopressin neurons in human hypothalamus and for neuronal terminals of these neurons in the posterior

pituitary with both antibody preparations (data not shown). Alternatively, negative staining was obtained with both of these antibodies in the 17 cases of benign breast disease. In several tissue sections staining of mononuclear cells was evident. Staining of sections with pre-immune rabbit serum resulted in a lack of staining. As demonstrated previously, Fig 1a demonstrates positive staining of an acetone-fixed infiltrating ductal breast cancer biopsy specimen with the vasopressin-associated glycopeptide antibody (North et al., 1995). In this section the breast cancer cells demonstrate intense staining, and the normal ducts of the breast are unstained. Figure 1b demonstrates a tissue section of fibrocystic disease with adenosis which showed no immunostaining with the antibody to vasopressin-associated glycopeptide. A case of atypical ductal hyperplasia is represented in Fig 1c which exhibited negative staining with the antibody to vasopressin. It should be noted that the nuclei of cells appear dark because the nuclear counterstain hematoxylin was used. Follow-up of the medical records revealed that three individuals, one from each classification group, subsequently developed breast cancer.

Discussion

There is an increasing body of evidence which supports a connection between vasopressin and breast cancer. There are two published clinical reports of patients with breast cancer presenting with the syndrome of inappropriate antidiuretic hormone secretion (Gupta et al., 1986; Howard et al., 1993). Both *in vitro* and *in vivo* studies support a connection between vasopressin and breast cancer. Several studies indicate that a cell line derived from a dimethylbenz(a)anthracene-induced rat

mammary tumor possesses functional V_{1a} vasopressin receptors (Monaco et al., 1978; Monaco et al., 1980; Guillon, et al., 1986; Kirk et al., 1986; Woods and Monaco, 1988). Vasopressin was shown to have a growth-promoting influence on MCF-7 breast cancer cells, presumably through V_1 vasopressin receptors (Taylor et al., 1990). Another study has demonstrated that vasopressin-induces a rise in intracellular free calcium in a human breast cancer cell line (Bunn et al., 1992). In a transgenic mouse model of breast cancer, ectopic vasopressin was found to stimulate cancer growth, but did not influence the time to tumor onset (Chooi et al., 1994).

Using antibodies directed against various regions of the vasopressin prohormone and the technique of immunohistochemistry we found that expression of vasopressin gene-related products is a common feature of breast cancers (North et al., 1995). In the present study it was found that the various cases of fibrocystic disease did not exhibit staining with antibodies directed against vasopressin or vasopressin-associated glycopeptide. These two antibodies had previously given positive immunostaining with all of the breast cancer specimens examined. The results obtained in the present study suggest that expression of vasopressin gene-related products is associated with the carcinogenic process and not with benign breast disease. These results also indicate that expression of vasopressin gene-related products is not just a marker of proliferation in the breast as indicated by the lack of staining of the tissue sections consisting of hyperplasia. Examination of subsequent medical records for these patients indicated that 3 of these cases (1 case of fibrocystic disease without hyperplasia, 1 case of fibrocystic disease with

hyperplasia, 1 case of fibrocystic disease with atypical hyperplasia) went on to develop breast cancer. Although the sample number is small these findings suggest that vasopressin gene-related products are not markers of premalignant lesions which will subsequently develop into breast cancer. Such findings are consistent with those obtained by Chooi et al. (1994) with MMTV-VP vasopressin transgenic mice. In these animals it was observed that vasopressin had no influence on normal mammary gland function and development, and did not cause the development of hyperplastic alveolar nodules and ductal hyperplasia. Taken together, these data are suggestive that vasopressin gene expression is not involved in benign breast disease, and is not a marker of preneoplastic changes in the breast. It would therefore seem to be a marker of the carcinogenic process in the breast. We are in the process of examining cases of carcinoma *in situ* to determine if vasopressin gene-related products are detectable at this stage of breast cancer.

Acknowledgments

We thank Susan Gagnon and Maudine Waterman for technical assistance. This work was supported by grants to William G. North, PHS (CA 19613) and DOD (DAMD 17-94-j-4288), and through the NCI core grant of the Norris Cotton Cancer Center (CA 23108). Through the course of this work Michael J. Fay was supported by an NIH training grant (DK 07508), and a DOD fellowship (DAMD 17-94-j-4131).

References

- Bunn, P.A., Dienhart, D.G., Chan, D., Tagawa, M., and Jewett, P. (1992). Effects of neuropeptides on human lung and breast cancer cells. *J. Natl. Cancer Inst. Monogr.* **13**, 145-151.
- Chooi, K., Carter, D.A., Biswas, S., Lightman, S.L., Ho, M., and Murphy, D. (1994). Ectopic vasopressin expression in MMTV-*Wnt-1* transgenic mice modifies mammary tumor differentiation and pathology. *Cancer Res.* **54**, 6434-6440.
- Connolly, J.L., and Schnitt, S.J. (1993). Benign Breast Disease resolved and unresolved issues. *Cancer* **71**, 1187-1189.
- Dupont, W.D., and Page D.L. (1985). Risk factors for breast cancer in women with proliferative breast disease. *N. Engl. J. Med.* **312**, 146-151.
- Dupont, W.D., Parl, F.F., Hartmann, W.H., Brinton, L.A., Winfield, A.C., Worrell, J.A., Schuyler, P.A., and Plummer, W.D. (1993). Breast cancer risk associated with proliferative breast disease and atypical hyperplasia. *Cancer* **71**, 1258-1265.
- Friedmann, A.S., Malott, K.A., Memoli, V.A., Pai, S.I., Yu, X., and North, W.G. (1994). Products of vasopressin gene expression in small-cell carcinoma of the lung. *Br. J. Cancer* **69**, 260-263.

- Guesdon, J.L., Ternynck, T., Avaremeas, S. (1979). The use of avidin-biotin interaction in immunoenzymatic techniques. *J. Histochem. Cytochem.* 27, 1131-1139.
- Guillon, G., Kirk, C.J., and Balestre, M. (1986). Characterization of specific V_{1a} vasopressin-binding sites on a rat mammary-tumor-cell line. *Biochem. J.* 240, 189-196.
- Gupta, A., Sasarula, S., Rao, P.V. (1986). The syndrome of inappropriate secretion of antidiuretic hormone in a case of carcinoma of the breast. *J. Assoc. Physicians India* 34, 441-442.
- Henderson, I.C. (1993). Risk factors for breast cancer development. *Cancer* 71, 2127-2140.
- Howard, A.C., Laing, R.W., and Hussain, F.N. (1993). Breast Carcinoma presenting with inappropriate ADH secretion. *Eur. J. Cancer* 29A, 2339, 1993.
- Kirk, C.J., Guillon, G., Balestre, M. and Jard, S. (1986). Stimulation, by vasopressin and other agonists, of inositol-lipid breakdown and inositol phosphate accumulation in WRK 1 cells. *Biochem J.* 240,197-204.
- London, S.J., Connolly, J.L., Schnitt, S.J., Colditz, G.A. (1992). A prospective study

of benign breast disease and the risk of breast cancer. *JAMA* 267, 941-944.

Monaco, M.E., Lippman, M.E., Knazek, R., and Kidwell, W.R. (1978). Vasopressin stimulation of Acetate incorporation into lipids in a dimethylbenz(a)anthracene-induced rat mammary tumor induced cell line. *Cancer Res.* 38, 4101-4104.

Monaco, M.E., Kidwell, W.R., and Lippman, M.E. (1980). Neurohypophysial-hormone-responsive cell line derived from a dimethylbenzanthracene-induced rat mammary tumor. *Biochem. J.* 188, 437-441.

North, W.G. (1991). Neuropeptide production by small cell carcinoma: vasopressin and oxytocin as plasma markers of disease. *J. Clin. Endocrinol. Metab.* 73, 1316-1320.

North, W.G., Pai, S., Friedmann, A., Yu, X., Fay, M., and Memoli, V. (1995). Vasopressin gene related products are markers of human breast cancer. *Breast Cancer Res. Treatment* 34, 229-235.

Streefkerk, J.G. (1972). Erythrocyte pseudoperoxidase activity by treatment with hydrogen peroxide following methanol. *J. Histochem. Cytochem.* 20, 829-831.

Taylor, A.H., Ang, V.T.Y., Jenkins, J.S., Silverlight, J.J., Coombes, R.C., and Luqmani, Y.A. (1990). Interaction of vasopressin and oxytocin with human breast carcinoma cells. *Cancer Res.* 50, 7882-7886.

Waddell, W.J. (1956). A simple ultraviolet spectrophotometric method for the determination of protein. *J. Lab. Clin. Med.* 48, 311-314, 1956.

Woods, D.J., and Monaco, M.E. (1988). Characterization of the vasopressin receptor on WRK-1 cells. *Mol. Endocrinol.* 2, 350-354.

Figure 1 a, Positive staining for vasopressin-associated glycopeptide in a tissue section of infiltrating ductal breast cancer. Note the lack of staining in a normal structure, as indicated by the arrow (magnification = 147 x). b, Negative staining for vasopressin in a tissue section of fibrocystic disease with atypical ductal hyperplasia (magnification = 147 x). c, Negative staining for vasopressin-associated glycopeptide in a tissue section of fibrocystic disease with adenosis (magnification = 147 x).

MCF-7 breast cancer cells express normal forms of all vasopressin receptors plus an abnormal V_2R^{\star}

William G. North^{*}, Michael J. Fay¹, Jinlin Du

Department of Physiology, Dartmouth Medical School, Borwell 752E, 1 Medical Center Drive, Lebanon, NH 03756, USA

Received 4 January 1999; accepted 25 February 1999

Abstract

We have previously provided evidence that an autocrine loop involving vasopressin is present in perhaps all breast cancers. This study now shows MCF-7 breast cancer cells express mRNAs for all currently recognized vasopressin receptor subtypes (V_{1a} , V_{1b} , and V_2). Cloning and DNA sequencing over the entire open reading frame of each mRNA revealed that normal sequences representing each receptor were present. However, in addition, an abnormal mRNA for the V_2 receptor, expected to give rise to a truncated 'diabetic' protein, was also expressed. Western analysis revealed that all three normal mRNAs gave rise to proteins of sizes compatible with them being functional receptors. The abnormal V_2 receptor mRNA also gave rise to proteins. © 1999 Elsevier Science Inc. All rights reserved.

Keywords: Vasopressin; Receptors; Breast cancer

1. Introduction

Vasopressin is reported to have growth-promoting activity on cells of the breast cancer cell line MCF-7 [22]. Such an action would require these cells to express at least one subtype of vasopressin receptor, presumably the V_{1a} receptor subtype, but this has not yet been demonstrated. In addition, no attempt has been made to discover if two other receptor subtypes, vasopressin V_{1b} and V_2 receptors, are also present. Although all three receptors are G-linked proteins possessing seven membrane-spanning domains, vasopressin binding to V_{1a} or V_{1b} subtypes promotes phospholipase activities whereas binding to the V_2 subtype primarily promotes adenylate cyclase activity and the formation of cyclic AMP (cAMP). Recently, we were able to show that both classic and variant forms of small-cell lung cancer (SCLC) express all three receptor subtypes, plus a putative

human vasopressin-activated calcium mobilizing (hVACM) receptor [18,19]. However, although a normal V_2 receptor subtype was apparently manufactured only by classic SCLC, both classic and variant SCLC generated an abnormal form of this receptor, apparently the product of incomplete posttranscriptional processing. In the current study, reverse transcription polymerase chain reaction (RT-PCR), cloning, and DNA sequencing were used to obtain mRNA sequences that encompassed the entire open reading frame of each of the human vasopressin V_{1a} , V_{1b} , and V_2 receptor subtypes. In addition, antibodies specific to each receptor subtype were used in Western analysis to examine the nature of protein products resulting from mRNA translation.

2. Methods

2.1. Cell culture and human tissues

The breast cancer cell line MCF-7 was purchased from the American Type Culture Collection (Rockville, MD, USA). This cell line has been shown to express vasopressin gene-related products by immunocytochemistry [17], and by Western analysis (unpublished data). Cells were maintained in Dulbecco's modified Eagle's medium (Sigma, St.

^{*} This work was supported in part by an award from the Department of Defense (DAMD17-94-J-4288) and a PHS award from the National Cancer Institute (CA 19613).

^{*} Corresponding author. Tel.: +1-603-650-7736; fax: +1-603-650-6130.

E-mail address: William.G.North@dartmouth.edu (W.G. North)

¹ Present address: Midwestern University, Chicago College of Osteopathic Medicine, Department of Pharmacology, 555 31st Street, Downers Grove, IL 60515, USA.

Table 1
Primers and antibodies designed for RT-PCR, sequencing, and Western blot analysis of vasopressin receptors in breast cancer cells

Vasopressin receptor	PCR and sequencing primers				Western blot antibodies		
	Primer name	Length	Nucleotide location	Strand	Antibody name	Peptide ^a antigen	Protein location
V _{1a} receptor	A1	20	-23--4	+	Vivian	H-(Y)VNNVTKARD-NH ₂	194–202
	A2	20	823–842	+			
	A3	22	145–166	+			
	B	20	795–814	-			
	C	18	1258–1275	-			
	D	20	412–431	-			
V _{1b} receptor	F0	20	-123--104	+	Bivity	H-(Y)PLWDANPTP-NH ₂	5–13
	F5	21	394–414	+			
	F4	20	947–966	+			
	R3	18	493–512	-			
	R5	21	1008–1028	-			
	R0	20	1308–1325	-			
V ₂ receptor	A	20	40–59	+	Rocket Abner ^b	H-(Y)VEGGSGVTD-NH ₂ H-(Y)LEGGCSRG-OH	183–191 302–309
	C	20	379–398	+			
	D	20	1221–1240	+			
	F	21	837–857	+			

RT-PCR, reverse transcription-polymerase chain reaction.

^a The tyrosine residue shown in parentheses is not part of the receptor protein sequence and was added to the structure of the antigen to allow it to be iodinated. Each peptide was coupled to bovine thyroglobulin for immunizations.

^b The antigen used to generate Abner antibodies represents the C-terminal eight-amino-acid residues of an abnormal truncated V₂ receptor. Its complete gene and protein sequences can be found at National GenBank under the accession number AF032388.

Louis, MO, USA) supplemented with 1 mM sodium pyruvate, 10 µg/ml bovine insulin, and 10% fetal bovine serum (HyClone, Logan, UT, USA) and grown as a monolayer in a humidified atmosphere of 5% CO₂ at 37°C.

2.2. RNA isolation and RT-PCR

Total RNA was isolated from cells by using TRIZOL Reagent (Life Technologies, Inc, Gaithersburg, MD, USA). This total RNA (1–5 µg) was added into a SuperScript preamplification system (Life Technologies) for the synthesis of the first cDNA strand by using an oligo(dT) primer and reverse transcriptase (400 U), and the product used directly for PCR. PCR was performed in a thermocycler (ERICOMP, San Diego, CA, USA). The reaction mixtures were overlaid with 50 µl of mineral oil and subjected to an initial denaturation at 96°C for 2 min, followed by 30 cycles comprising a denaturation step at 96°C for 30 s, a step for annealing the primers to the template at 58°C for 1 min 30 s, and an extension step at 72°C for 1 min 30 s. At the completion of the cycling reaction, an additional extension step at 72°C for 10 min was performed. Features of primers selected for PCR and sequencing of V_{1a}, V_{1b}, and V₂ receptors are summarized in Figs. 1a, 2a, and 3a, and in Table 1. These primers were synthetic 18, 20, and 22 oligomers designed to yield overlapping PCR products of 452, 454, and 669 bp for V_{1a} receptors; synthetic 18 and 20 oligomers yielding overlapping PCR products of 380, 634, and 635 bp for V_{1b} receptors; and synthetic 20 oligomers providing overlapping PCR products of 817 and

862 bp for V₂ receptors. These PCR products for V₁ and V₂ receptors collectively spanned the entire open reading frame of the receptor mRNAs. PCR products were extracted with an equal volume of chloroform and examined on 2% agarose gels.

2.3. Cloning and sequencing

PCR products (1 µl, 4–12 ng) of vasopressin receptors were ligated into a pCR vector and 2 µl of the ligation mixture transformed in One Shot Competent Cells by using a TA Cloning Kit (Invitrogen, San Diego, CA, USA). Plasmid clones were prepared with a Wizard Minipreps DNA purification system (Promega, Madison, WI, USA), and screened by *EcoRI* digestion and agarose gel electrophoresis. At least two positive clones of each PCR product were chosen for double-strand cDNA sequencing with a DyeDeoxy Terminator Cycle Sequencing Kit (Applied Biosystems, Perkin-Elmer, Foster City, CA, USA). The primers chosen for PCR amplifications, as described in Figs. 1a, 2a, 3a and vector universal primers (M13 forward and M13 reverse), together served as sequencing primers. The protocol for sequencing cloned cDNA (1 µg) was as follows: 96°C, 2 min; 25 cycles at 96°C, 15 s, 50°C, 15 s, and 60°C, 4 min. The products were purified with Centri-Sep spin columns (Princeton Separations, Adelphia, NJ, USA). Automated DNA sequencing was performed by using a Model 373 DNA Sequencer from Applied Biosystems, Perkin-Elmer.

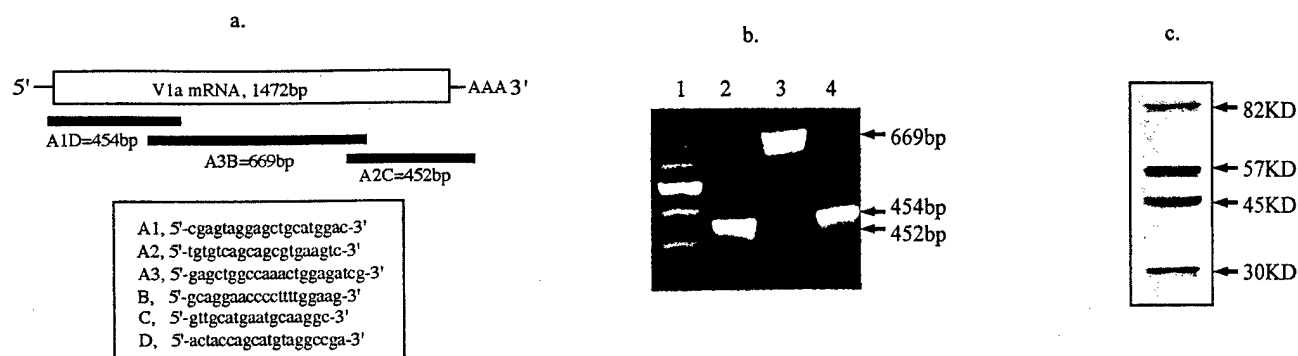

Fig. 1. Evaluations for human vasopressin V_{1a} receptors from the MCF-7 breast cancer cell line. (a) Synthetic primers selected for reverse transcription-polymerase chain reaction (RT-PCR) and sequencing. (b) RT-PCR products from a total RNA preparation separated on a 2% agarose gel and visualized with ethidium bromide. Lane 1, 100-bp DNA ladder; lane 2, 452-bp product of expected size obtained with primers A1 and D; lane 3, 669-bp product of expected size obtained with primers A3 and B; lane 4, 454-bp product of expected size obtained with primers A2 and C. (c) Western blot analysis from sodium dodecyl sulfate polyacrylamide gel electrophoresis (12%) with an enhanced chemiluminescence (ECL) detection system (Amersham) showing dithioerythritol-reduced proteins of \approx 82, 57, 45, and 30 kDa that were immunoreactive with rabbit polyclonal antibodies (Vivian 3).

2.4. Polyclonal antibodies and Western analysis

Rabbit polyclonal antibodies to the human vasopressin V_{1a} , V_{1b} , and V_2 receptors, and an abnormal form of V_2 receptors, were generated by using procedures similar to those described previously [18,19]. Decapeptide amides, nonapeptide amides, or decapeptides representing eight to 10 amino acid unique sequences in each of the four receptor forms with an added N-terminal tyrosine (to permit iodide labeling), when this amino acid was not already present in the sequence chosen, were used as antigens [18,19]. Table 1 illustrates the nature of these peptides and their sequential location from the N-terminus of respective translated receptor proteins. Antibodies from antisera (Vivian for V_{1a} receptor, Bivily for V_{1b} receptor, Rockie for V_2 receptor, and Abner for the abnormal V_2 receptor) obtained in this manner were isolated as IgG_{2b} fractions from protein A-Sepharose (Sigma) chromatography for use in Western blot analysis at concentrations of 10 μ g/ml. Samples for Western analysis were prepared by sonicating cells ($0.4\text{--}1.2 \times 10^7$) in 1.0 ml of lysis buffer (10 mM Tris-HCl, 5 mM EDTA, 50 mM NaCl, 30 mM NaH_2PO_4 , 50 mM NaF, 0.1 mM Na_3VO_4 , 1 mM phenylmethylsulfonyl fluoride, 0.2 IU/ml aprotinin, 0.1% Triton X-100, pH 7.6). Homogenates were centrifuged for 2 min at $12\,000 \times g$ and ambient temperature. Soluble extracts were mixed 1:1 with $2\times$ sodium dodecyl sulfate (SDS)/Tris-HCl sample buffer (pH 8.7) containing 50 mM dithiothreitol, and proteins reduced by heating at 100°C for 5 min. These proteins were then subjected to SDS-polyacrylamide gel electrophoresis on 12% gels at pH 9.3, by using the method of Laemmli [12]. Separated proteins were electrophoretically transferred in 20 mM Tris-glycine to immobilon polyvinylidene difluoride (PVDF) membranes. These membrane transfers were dried and incubated for 16 h at 4°C , with rabbit polyclonal antibody preparation against V_{1a} , V_{1b} , and V_2 normal, or V_2 abnormal receptors (see above) in pH 7.4 Tris-HCl buffer

[10 mM Tris-HCl, 100 mM NaCl, 5% bovine serum albumin (BSA), and 0.1% Tween 20]. After washings ($\times 3$) in the pH 7.4 buffer, membrane transfers were incubated with a goat anti-rabbit IgG horseradish peroxidase conjugate for 1 h. Each was removed by washing ($\times 3$) in Tris-HCl buffer, pH 7.4. Transfers were sometimes placed in a 1:50 dilution of 33% H_2O_2 in methanol for 30 min before blocking (to destroy endogenous peroxidase activity in the sample). Immunoreactive proteins in peroxidase-treated transfers were visualized by using an enhanced chemiluminescence (ECL) Western Blotting Detection System (Amersham Life Sciences, Arlington Heights, IL, USA) with exposure of X-ray film from 30 s to 120 s. Prestained SDS-polyacrylamide gel electrophoresis standard proteins (Bio-Rad Laboratories, Hercules, CA, USA) were used as molecular size markers.

3. Results

3.1. RT-PCR, cloning, and DNA sequencing

By using forward and reverse primers selected to provide overlapping sequences covering the entire open reading frames of vasopressin V_{1a} , and V_{1b} mRNAs, RT-PCR of total RNA preparations from MCF-7 cells yielded, in each case, a single product of the expected size predicted from the cDNA for the human forms of these receptors derived from liver [24] or blood vessels [8], from pituitary [6,21]; and from SCLC [19]. All of the products were generated from RNA and not DNA template because no intronic segments that these products spanned were evident. The three products obtained for the V_{1a} receptor (452, 454, and 669 bp), and the three obtained for the V_{1b} receptor (635, 634, and 380 bp) are shown in Fig. 1a and 1b and Fig. 2a and 2b. However, RT-PCR with forward and reverse primers selected to obtain overlapping sequences covering the entire sequence of vasopressin V_2 mRNA (Fig. 3a) gave not

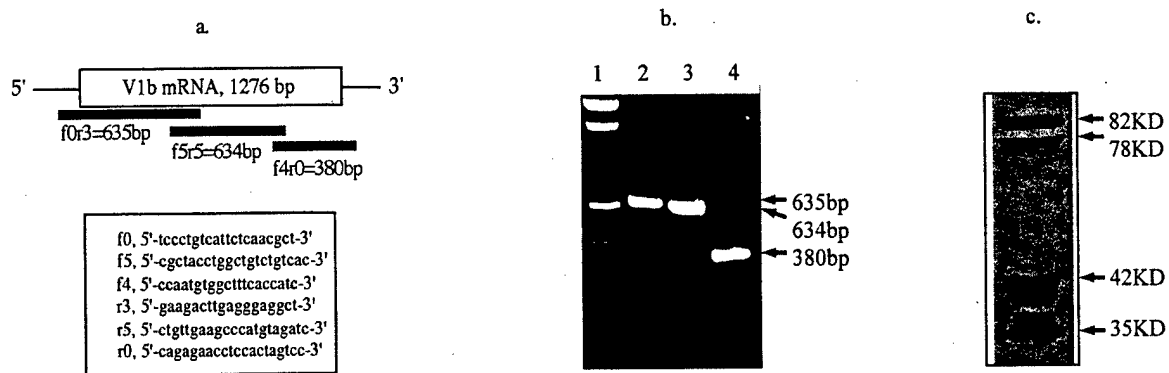

Fig. 2. Evaluations for human vasopressin V_{1b} receptors from the MCF-7 breast cancer cell line. (a) Synthetic primers selected for RT-PCR and sequencing. (b) RT-PCR products from a total RNA preparation separated on a 2% agarose gel and visualized with ethidium bromide. Lane 1, 100-bp DNA ladder; lane 2, 635-bp product of expected size obtained with primers f0 and r3; lane 3, 634-bp product of expected size obtained with primers f5 and r5; lane 4, 380-bp product of expected size obtained with primers f4 and r0. (c) Western blot analysis from sodium dodecyl sulfate polyacrylamide gel electrophoresis (12%) with an enhanced chemiluminescence (ECL) detection system (Amersham) showing dithioerythritol-reduced proteins, \approx 82, 78, 42, and 35 kDa from MCF-7 cells that were immunoreactive with rabbit polyclonal antibodies (Bivily 3).

only normal products [2], but also one abnormally sized product (Fig. 3b). The abnormal form was obtained as a second product when primers spanning intron 2 were used and was larger by the size of this intron (\approx 100 bp) than the size of 862 bp, predicted from the structure of V_2 receptor mRNA. A similar product was earlier reported by us to be a product of SCLC [19]. Cloning and sequencing of all V_{1a} - and V_{1b} -related products, and V_2 -related products of predicted size, showed them to collectively provide a complete characterization of human V_{1a} mRNA for the MCF-7 breast cancer cell line from -23 at the 5' end (23 bases before the reading frame) through 1224 at the 3' end (18 bases beyond the reading frame), for V_{1b} mRNA from 123 bases beyond the 5' end to 52 bases beyond the 3' end, and for V_2 mRNA from 32 bases beyond the 5' end to 53 bases beyond the 3' end. The sequences for the vasopressin V_1 receptor mRNAs

had exact sequence homology with the sequence of human V_{1a} mRNA and the sequence of human V_{1b} mRNA published earlier by us and others [6,19,21,24]. One sequence of human V_2 receptor mRNA from breast cancer cells was identical to that published by us and others for normal human tissues [2,7]. In additionally, an enlarged product of the V_2 receptor was found to contain the entire 106 bases of intron 2 in addition to sequence for V_2 mRNA.

3.2. Western analysis

Western analysis by use of the protein A-isolated IgG_{2b} preparation of polyclonal antibodies against the V_{1a} receptor (Vivian 3) revealed the presence of major protein bands at \approx 82, 57, 45, and 30 kDa, although use of isolated polyclonal antibodies to V_{1b} receptor (Bivily 3) gave prominent

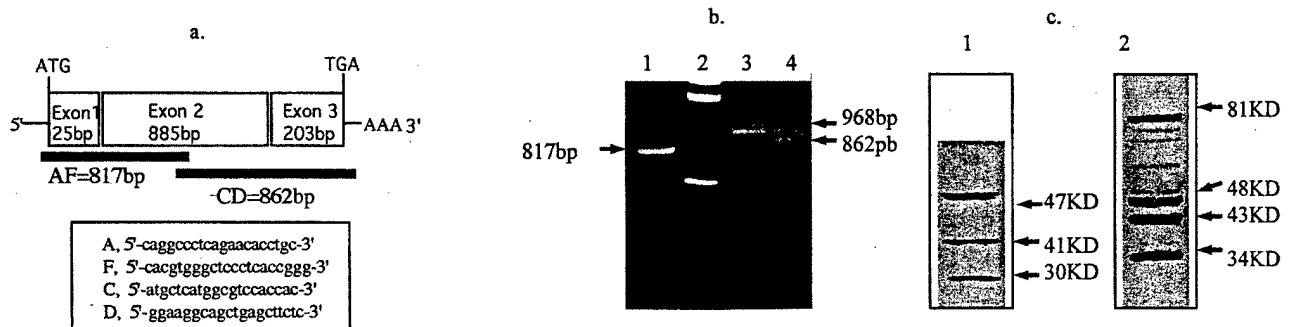

Fig. 3. Evaluations for human vasopressin V_2 receptors from the MCF-7 breast cancer cell line. (a) Synthetic primers selected for RT-PCR and sequencing. (b) RT-PCR products from a total RNA preparation separated on 2% agarose gels and visualized with ethidium bromide. Lane 1, 817-bp product of expected size obtained with primers A and F; lane 2, 100-bp DNA ladder; lane 3, 968-bp product of enlarged size obtained with primers C and D from H82 small-cell lung cancer cells [2]; lane 4, 862-bp product of expected size and 968-bp product of enlarged size obtained with primers C and D from MCF-7 breast cancer cells. (c) Western blot analysis from sodium dodecyl sulfate polyacrylamide gel electrophoresis (12%) with an enhanced chemiluminescence (ECL) detection system (Amersham) showing the following: Lane 1, dithioerythritol-reduced proteins of \approx 47, 41, and 30 kDa from MCF-7 cells that were immunoreactive with rabbit polyclonal antibodies against the normal receptor (Rockie 3); lane 2, dithioerythritol-reduced proteins of \approx 81, 48, 43, and 34 kDa immunoreactive with antibodies against an abnormal form of the receptor (Abner 3).

protein bands at ≈ 82 , 78, 42, and 35 kDa. Western analysis with polyclonal antibodies to the vasopressin V_2 receptor (Rockie 3) demonstrated prominent protein bands at ≈ 47 , 41, and 30 kDa. These could represent products of both the normal V_2 mRNA and the abnormal V_2 mRNA because both types of receptor proteins (and some of their metabolites) should react with Rockie antibodies that recognize an epitope in the N-terminal region. When antibodies against the abnormal vasopressin V_2 structure (Abner 3) were used on MCF-7 cell extracts, prominent protein bands at 81, 48, 43, 40, and 34 kDa were displayed. These immunoreactive proteins would represent only the abnormal receptor plus glycosylated and N-terminally truncated metabolites because Abner antibodies specifically recognize the abnormal C-terminus. Data from profiles representing Western analysis performed by using the enhanced chemiluminescence (ECL) procedure and antibodies against V_{1a} , V_{1b} , and V_2 receptor proteins from MCF-7 breast cancer cells are illustrated in Figs. 1c, 2c, and 3c.

4. Discussion

Breast cancer, exemplified here by MCF-7 cells, is shown for the first time to express gene products for not one, but all three of the currently recognized receptor subtypes (V_{1a} , V_{1b} , and V_2) for the hormone vasopressin. In addition, an mRNA for the putative human vasopressin receptor known as human vasopressin-activated calcium mobilizing (hVACM) receptor [13] was also shown to be expressed by MCF-7 cells, but details of these studies will be presented elsewhere. With respect to V_{1a} and V_{1b} receptor subtypes, a single mRNA is produced and each was found to have sequence identity with those expressed by normal tissues [21,24]. For the V_2 receptor subtype, both a sequentially normal form of mRNA [2,7] and a sequentially abnormal form of mRNA were present in these cells.

The abnormal mRNA expressed by MCF-7 cells is identical to the larger form of V_2 receptor mRNA produced by small-cell carcinoma [19]. This mRNA contains the entire structure for intron 2 of the gene, and is apparently the product of incomplete splicing [2]. The introduction of a *tag* stop codon into the reading frame, a short distance from the 5' end of the transcribed intron, starting at base position 1359 of the gene, leads us to expect this mRNA will translate into a C-terminally truncated receptor lacking the seventh transmembrane domain. That this mRNA is translated into protein products is supported by the presence in MCF-7 cell extracts of proteins immunoreactive with antibodies solely recognizing this abnormal truncated C-terminal structure. A similar receptor, lacking the seventh transmembrane domain and C-terminus of the normal V_2 receptor, is predicted to be produced through a single base substitution in the inherited form of nephrogenic diabetes insipidus known as the 'Utah' type [3]. Because the Utah receptor appears to be nonfunctional, it is likely that the abnormal tumor recep-

tor is either also nonfunctional, or serves as a 'null' receptor if able to bind peptide and be expressed at the surface of cells. However, the studies of Sadeghi et al. [20] suggest that receptor proteins lacking the seventh transmembrane domain might not become components of the plasma membrane. Of perhaps more significance to tumor cell regulation are the recent studies of Zhu and Wess [28] that predict this truncated receptor would serve to inhibit the function and cell trafficking of full-length V_2 receptor possibly through the formation of a heterodimeric structure.

Both normal and abnormal mRNAs of MCF-7 breast cancer cells were shown to be translated into receptor proteins that are recognized through interactions with specific antibodies. The protein products of all three normal mRNAs seem to be of sizes (30–50 kDa and 70–87 kDa) compatible with them being glycosylated and nonglycosylated forms of functional receptors [2,6,11,24]. The expression by breast cancer cells of both V_1 and V_2 receptors implies that vasopressin can initiate a whole range of intracellular cascades that include activation of phospholipases and protein kinase C, as well as activation of adenylate cyclase and protein kinase A [1,10,23,25–27].

A common feature of breast cancer would seem to be an autocrine loop involving vasopressin, because coupled with the current findings we have earlier obtained evidence that vasopressin is produced by apparently all breast cancers [16]. The growth-promoting actions reported for vasopressin, on MCF-7 breast cancer cells by Taylor et al. [22], and on mammary tumors by Chooi et al. [5], are presumably exercised through V_{1a} and/or V_{1b} receptors. These receptors are reported to activate phospholipases A_2 , C, D, and protein kinase C, raise intracellular free Ca^{2+} , and increase phosphorylation of mitogen-activated protein (MAP) kinase and of focal adhesion kinase (FAK), in normal tissues and in small-cell cancer cells. All of these transduction cascades have been associated with cellular mitogenesis [1,23,25–27]. However, Taylor et al. [22] also showed that vasopressin can inhibit the growth of MCF-7 cells. We believe there is a growing body of supportive evidence that this negative influence on growth of the peptide could be exercised through normal vasopressin V_2 receptors, and have earlier proposed this for SCLC [19].

In support of a vasopressin V_2 receptor-related mechanism being involved with the growth inhibition of breast cancer cells are the earlier findings that growth inhibition, as well as growth promotion and cellular differentiation in tumors, can be associated with changes in cAMP [9,14,15]. More recently and significantly, Cassoni et al. [4] have demonstrated that inhibition of a breast cancer cell line is produced by rises in cAMP. Because vasopressin raises cAMP by activating V_2 receptors, it seems likely the peptide can inhibit growth through this mechanism. If this is indeed the case, it means vasopressin through its different receptors is exercising a multifaceted, rather than a simple mitogenic role in the growth and survival of breast cancer, and can best be described as an autocrine growth modulatory agent, in

much the same way it is regarded as a neuromodulatory agent in the central nervous system. It is also possible such eclectic properties are exhibited not only by vasopressin, but by most, or all, other autocrine tumor growth factors.

Acknowledgments

Excellent technical assistance was provided by Susan Gagnon, Leslie Sandberg, and Alison North.

The nucleotide sequences reported in this manuscript have been submitted to the GenBank with accession numbers AF101725, AF101726, AF101727, and AF101728.

References

- [1] Bilezikjian LM, Blount AL, Vale WW. The cellular actions of vasopressin on corticotrophs of the anterior pituitary: resistance to glucocorticoid action. *Mol Endocrinol* 1997;1:451–8.
- [2] Birnbaumer M, Seibold A, Rosenthal W, Bichet DG. The human ADH receptor: the gene, the cDNA, the protein. In: Gross P, Richter D, Robertson GL, editors. *Vasopressin*. Paris: John Libbey Eurotext, 1993. p. 19–31.
- [3] Brownstein MJ, Lolait SJ. Hereditary nephrogenic diabetes insipidus. In: Gross P, Richter D, Robertson GL, editors. *Vasopressin*. Paris: John Libbey Eurotext, 1993. p. 33–43.
- [4] Cassoni P, Sapino A, Fortunati N, Munaron L, Chini B, Bussolati G. Oxytocin inhibits the proliferation of MDA-MB231 human breast-cancer cells via adenosine monophosphate and protein kinase A. *Int J Cancer* 1997;72:340–4.
- [5] Chooi KF, Carter DA, Biswas S, Lightman S, Ho MY, Murphy D. Ectopic vasopressin expression in MMTV-Wnt-1 transgenic mice modifies mammary tumor differentiation and pathology. *Cancer Res* 1994;54:6434–40.
- [6] de Keyzer Y, Auzan C, Lenne F, Beldjord C, Thibonnier M, Bertagna X, Clauser E. Cloning and characterization of the human V3 pituitary vasopressin receptor. *FEBS Lett* 1994;356:215–20.
- [7] Fay MJ, Du J, Yu X, North WG. Evidence for expression of vasopressin V2 receptor mRNA in human lung. *Peptides* 1996;17:477–81.
- [8] Hirasawa A, Shibata K, Kotosai K, Tsujimoto G. Cloning, functional expression and tissue distribution of human cDNA for the vascular-type vasopressin receptor. *Biochem Biophys Res Commun* 1994;203:72–9.
- [9] Kaur G, Viallet J, Laborda J, Blair O, Gazar AF, Minna JD, Sausville EA. Growth inhibition by cholera toxin of human lung carcinoma cell lines: correlation with GM1 ganglioside expression. *Cancer Res* 1992;52:3340–6.
- [10] Kimura K. Expression of vasopressin V2 receptor in *Xenopus laevis* oocytes by porcine kidney cell line (LLC-PK) messenger RNA. *Biochem Biophys Res Commun* 1990;174:149–55.
- [11] Kojro E, Eich P, Fahrenholz F. Purification and molecular structure of the photoaffinity labeled V₂-vasopressin receptor from bovine kidney. In: Gross P, Richter D, Robertson GL, editors. *Vasopressin*. Paris: John Libbey Eurotext, 1993. p. 582.
- [12] Laemmli UK. Cleavage of structural proteins during the assembly of the head of bacteriophage T4. *Nature (London)* 1970;227:680–5.
- [13] Longo KA, Fay MJ, North WG. Evidence for the expression of a novel vasopressin-activated calcium mobilizing receptor (VACM-1) in human breast cancer and lung cancer. *Mol Biol Cell* 1996;7:3761.
- [14] Maneckjee R, Minna JD. Nonconventional opioid binding sites mediate growth inhibitory effects of methadone on human lung cancer cells. *Proc Natl Acad Sci USA* 1992;89:1169–73.
- [15] Moody TW, Zia F, Draoui M, Brennerman DE, Fridkin M, Davidson A, Gozes I. A vasoactive intestinal peptide antagonist inhibits non-small cell lung cancer growth. *Proc Natl Acad Sci USA* 1993;90:4345–9.
- [16] North WG, Pai S, Friedmann AS, Fay MJ, Yu X-M, Memoli VA. Vasopressin gene-related products are markers of human breast cancer. *Breast Cancer Res Treat* 1995;34:229–35.
- [17] North WG, Fay MJ, Longo K, Du J. Vasopressin gene-related products in the management of breast cancer. *DOD Breast Cancer Res Era Hope Proc* 1997;2:795–6.
- [18] North WG, Fay MJ, Longo K, Du J. Functional V1 vasopressin receptors are present in both variant and classical forms of small-cell tumor cells. *Peptides* 1997;18:985–93.
- [19] North WG, Fay MJ, Longo K, Du J. Expression of all known vasopressin receptor subtypes by small cell tumors implies a multifaceted role for this neuropeptide. *Cancer Res* 1998;58:1866–71.
- [20] Sadeghi HM, Innamorati G, Birnbaumer M. An X-linked NDI mutation reveals a requirement for cell surface V2R expression. *Mol Endocrinol* 1997;11:706–13.
- [21] Sugimoto T, Saito M, Mochizuki S, Watanabe Y, Hashimoto S, Kawashima H. Molecular cloning and functional expression of a cDNA encoding the human V1b vasopressin receptor. *J Biol Chem* 1994;269:27088–92.
- [22] Taylor AH, Ang VTY, Jenkins JS, Silverlight JJ, Coombes RC, Lauqmani YA. Interaction of vasopressin and oxytocin with human breast cancer cells. *Cancer Res* 1990;50:7882–6.
- [23] Thibonnier M, Bayer AL, Leng Z. Cytoplasmic and nuclear signaling pathways of the V1-vascular vasopressin receptors. *Reg Peptides* 1993;45:79–84.
- [24] Thibonnier M, Auzan C, Madhun Z, Wilkins P, Berti-Mattera L, Clauser E. Molecular cloning, sequencing, and functional expression of a cDNA encoding the human V1a vasopressin receptor. *J Biol Chem* 1994;269:3304–10.
- [25] Zachary I, Sinnott-Smith J, Rozengurt E. Stimulation of tyrosine kinase activity after addition of bombesin, vasopressin, and endothelin to intact cells. *J Biol Chem* 1991;266:24126–33.
- [26] Zachary I, Sinnott-Smith J, Rozengurt E. Bombesin, vasopressin, and endothelin stimulation of tyrosine phosphorylation in Swiss 3T3 cells. *J Biol Chem* 1992;267:19031–4.
- [27] Zachary I, Sinnott-Smith J, Turner CE, Rozengurt E. Bombesin, vasopressin, and endothelin rapidly stimulates tyrosine phosphorylation of focal adhesion-associated protein paxillin in Swiss 3T3 cells. *J Biol Chem* 1993;268:22060–5.
- [28] Zhu X, Wess J. Truncated V2 vasopressin receptors as negative regulators of wild-type V2 receptor function. *Biochemistry* 1998;37:15773–84.

BREAST CANCER CELLS EXPRESS KEY PEPTIDE PROCESSING ENZYMES

Jinlin Du and William G. North
Department of Physiology, Dartmouth Medical School, Lebanon, NH
03756

Running Title: Peptide processing enzymes in breast cancer.

Address for offprints and correspondence:

William G. North

Department of Physiology

Dartmouth Medical School

1 Medical Center Drive

Lebanon, NH 03756

Tel: (603)650-7736 Fax: (603)650-6130

E-mail: William.G.North@DARTMOUTH.EDU

Summary

Prohormone convertases (PCs), carboxypeptidases (CPs) and peptidylglycine α -amidating monooxygenase (PAM) are the major classes of enzymes required for processing peptide growth factors and their receptors into biologically active forms. A number of growth factors and receptors, such as vasopressin and its receptors, have been shown to be present in breast cancer tissues and derived cell lines. In the current study, the expression of three key peptide processing enzyme families, represented by PC1/PC3, PC2, CPE and PAM, were examined in MCF-7 and ZR-75-1 breast cancer cell lines. Products of the expected sizes for PC1/PC3, CPE and PAM could be amplified by reverse transcription-polymerase chain reaction (RT-PCR) from both cell lines. Cloning and sequencing of these RT-PCR products revealed that each enzyme mRNA had a structure identical to that published for the human form of the respective enzyme. Western analysis provided evidence that mRNAs for these enzymes are translated into proteins. PC2 mRNA was identified to be present in MCF-7 cells both by RT-PCR and Western blot analysis, but could not be demonstrated for ZR-75-1 cells. Our findings suggest that the key processing enzymes needed to generate active peptide growth factors and their receptors are present in breast cancer cells.

Key Words: breast cancer, carboxypeptidase E, neuropeptide, peptidylglycine α -amidating monooxygenase processing, prohormone convertase, vasopressin

Introduction

Prohormone convertases (PCs) constitute a family of mammalian serine proteases that digest their substrates on the C-terminal side of the motif containing paired basic amino acids Lys-Arg or Arg-Arg (1). They are generally responsible for the first step in the conversion of precursors of polypeptide hormones, neuropeptides, growth factors and their receptors into biologically active forms (2, 3, 4, 5, 6). Besides PCs, two other key proteolytic enzymes, carboxypeptidase E (CPE) and peptidylglycine α -amidating monooxygenase (PAM), are also critically involved in the biosynthesis of many neuropeptides. These enzymes are necessary for C-terminal cleavage of basic amino acid residues and the posttranslational generation of peptide α -amidation, respectively (7, 8, 9).

It is believed that neoplastic cells express genes for peptide growth factors and their receptors, thus creating autocrine loops that promote proliferation of these cells (10). By the virtue of their property of generating biologically active growth factors and receptor molecules, processing enzymes may be strategically involved in the neoplastic process, particularly in neuropeptides expressing tumors. Evidence of the participation of proprotein convertases in tumorigenesis have been recently demonstrated for a number of human tumors including those of the human pituitary, pancreas, gut and lungs (9, 11, 12, 13, 14, 15, 16).

Production of possible neuropeptide autocrine loops, such as those related to vasopressin and oxytocin, have recently been identified in human breast cancer cells (17, 18, 19, 20). The relevance of such loops to breast cancer tumorigenesis is dependent on the ability of these tumors to produce processing enzymes from all three key families. Cheng and coworkers (21) and Scopsi and their coworkers (16) have recently performed initial studies in breast tumors and cancer cell lines, but they limited these studies only to some prohormone convertases. In the present study we employed RT-PCR and Western blot analysis to examine the expression of three key families of processing enzymes, represented by PC1/PC3, PC2, CPE, and PAM, involved in the generation of neuropeptides by two breast cancer cell lines (MCF-7 and ZR-75-1). Partial sequence analysis

Du

of expressed messages was also performed, and additionally, evidence sought to support translation of mRNAs into functional proteins.

Materials and Methods

Cell Culture

The MCF-7 and ZR-75-1 breast cancer cell lines were purchased from the American Type Culture Collection (Manassas, VA). In accordance with recommendations, MCF-7 cells were maintained in Dulbecco's Modified Eagle's medium (Sigma Chemical Co., St. Louis, MO) supplemented with 1mM sodium pyruvate, 10 µg/ml bovine insulin and 10% fetal bovine serum (HyClone, Logan, UT). ZR-75-1 cells were maintained in RPMI-1640 medium supplemented with 1.5 g/L sodium bicarbonate, 4.5 g/L glucose, 10 mM HEPES, 1.0 mM sodium pyruvate and 10% fetal bovine serum. Both cell lines were grown as monolayers in a humidified atmosphere of 5% CO₂ at 37°C.

RNA Isolation and RT-PCR

Total RNAs of MCF-7 and ZR-75-1 cells were isolated by Trizol Reagent, a single-step total RNA extraction solution purchased from GIBCO/BRL (Gaithersburg, MD). Total RNA (4 µl) was added into a 40 µl SuperScript preamplification system (GIBCO/BRL) including 2 µl of oligo (dT) primer and 400 U of reverse transcriptase for the synthesis of the first cDNA strand. PCR conducted in a thermocycler (ERICOMP, San Diego, CA) followed the completion of reverse transcription. The PCR reactions, containing 4 µl of RT mixture, 0.4 pmol/µl of primers and 2.5 U of Platinum Taq DNA polymerase (GIBCO/BRL) in a total of 50 µl reaction solution, were performed in the thermocycler as follows: one cycle at 97°C for 2 min., 30 cycles at 95°C for 30 sec., 58°C for 1 min. 30 sec. and 72°C for 1 min. 30 sec. At the completion of the cycling reaction, an additional extension step at 72°C for 10 min. was performed. The primers selected for PCR and partial sequencing of PC1/PC3, PC2, CPE and PAM are summarized in Figure 1a, 2a, 3a and 4a. These primers were synthetic 20, 21 and 24 oligomers designed to yield PCR products of 457, 880, 405 and 560 base pairs (bp) for PC1/PC3, PC2, CPE and PAM, respectively. PCR products were examined on 2% agarose gels and stained with 0.5 µg/ml ethidium bromide.

Du

Cloning and Sequencing

PCR products (1 μ l, 4-12 ng) related to PC1/PC3, PC2, CPE, and PAM, were each ligated into a pCR vector and 2 μ l of the ligation mixture transformed into One Shot Competent Cells using a TA Cloning Kit (Invitrogen, San Diego, CA). Plasmid cloned DNA was prepared with a Wizard Minipreps DNA purification system (Promega, Madison, WI.), and screened by EcoR I digestion and 2% agarose gel electrophoresis. At least two positive clones of each PCR product were chosen for double strand cDNA sequencing with a BigDye Terminator Cycle Sequencing Kit (Applied Biosystems, Perkin Elmer). The primers chosen for PCR amplifications as described in Figure 1a, 2a, 3a and 4a, and vector universal primers (M13 Forward, M13 Reverse and T7), together served as sequencing primers. In a total of 20 μ l sequence reaction mixture, 1 μ g of cloned cDNA and 3.2 pmoles of primer were added. The protocol for sequencing cloned cDNA was performed as follows: one cycle at 96°C, 2 min., 25 cycles at 96°C, 30 sec., 50°C, 15 sec., and 60°C, 4 min. The sequencing products were purified with Centri-Sep columns (Princeton, Adelphia, NJ), and automated DNA sequencing was performed using a Model 373 DNA Sequencer from Applied Biosystems.

Western Analysis

Samples for Western analysis were prepared by sonicating breast cancer cells ($0.4 - 1.2 \times 10^7$) in 1.0 ml of TES Buffer (20 mM Tris HCl, 1 mM EDTA, 150 mM NaCl, 0.2% SDS, pH 7.5). Homogenates were centrifuged for 2 minutes at 12,000 g at ambient temperature. Soluble extracts were mixed 1:1 with 2x SDS/Tris-HCl sample buffer (pH 8.7) containing 50 mM dithiothreitol (DTT), and proteins reduced by heating at 100°C for 5 min. These proteins were then subjected to sodium dodecyl sulfate-polyacrylamide gel electrophoresis (SDS-PAGE) on 12% gels at pH 8.3 using a previously described method (8). Separated proteins were electrophoretically transferred in 20 mM Tris glycine/20% MeOH to Immobilon-P polyvinylidene fluoride (PVDF) membranes (pore size, 0.45 μ m). These membrane transfers were dried and incubated for 16 h at 4°C with a 10-50 μ g/ml of protein A-purified rabbit polyclonal antibody preparations raised against PC1/PC3, PC2, CPE and PAM in pH 7.4 Tris HCl buffer (10 mM Tris HCl, 100 mM NaCl, 5% BSA, and

Du

0.1% Tween-20). The antibody preparations against PC1/PC3, PC2 and PAM, were kindly supplied by Drs. Betty Eipper and Richard Mains of Johns Hopkins University, and the antibody preparations against CPE were kindly supplied by Dr. Lloyd Fricker of Albert Einstein Medical School. The characteristics of these antibodies have been provided elsewhere by these individuals (7, 22). Following washing (x3) in the pH 7.4 buffer, membrane transfers were incubated with a goat anti-rabbit IgG-horseradish peroxidase conjugate for 1 h. Each was removed by washing (x3) in Tris HCl buffer, pH 7.4. Immunoreactive proteins in peroxidase-treated transfers were visualized using an ECL Western blotting detection system (Amersham Life Sciences, Arlington Heights, IL) with exposure of x-ray film from 30 sec. to 120 sec. Pre-stained SDS-PAGE standard proteins (Bio-Rad, Richmond, CA) were employed as molecular size markers.

Results

RT-PCR, Cloning and DNA Sequencing

As shown in Figure 1b, 3b and 4b, using forward and reverse primers designed for these enzymes from published PC1/PC3, CPE and PAM mRNA structures (8, 21, 22), a single product of each PC1/PC3 (457 bp), CPE (405 bp) and PAM (560 bp) cDNA was amplified by RT-PCR from total RNA preparations of both MCF-7 and ZR-75-1 breast cancer cell lines. RT-PCR of PC2 mRNA demonstrated a predicted cDNA product (880bp) from MCF-7 cells (Figure 2b), but not from ZR-75-1 cells using the conditions described in the methods section and previous publications (12, 15, 21). Cloning and sequencing of PC1/PC3, CPE and PAM related products obtained from both MCF-7 and ZR-75-1, and of the PC2 product from MCF-7, showed each of them has a sequence identical to those reported for the mRNA structures for each respective enzyme (8, 22, 23, 24).

Western Analysis

As we described previously (15), protein A-isolated IgG2b preparations of polyclonal antibodies against PC1/PC3, PC2, CPE and PAM enzymes were used in Western blots for both MCF-7 and ZR-75-1 breast cancer cells with the ECL procedure. As shown in Figure 1c and 3c, major protein bands at approximately 63, 50, 38 and 30 Kdaltons for PC1/PC3, and one prominent protein product at an appropriate size of 49 Kdaltons for CPE, were identified in both cell lines. Western

analysis for PAM immunoreactivity presented protein profiles showing differences between MCF-7 and ZR-75-1 cells (Figure 4c). The prominent form of PAM in MCF-7 cells was a protein product with an appropriate size of 38 Kdaltons, compared to protein forms ranging from 70 to 28 Kdaltons with major bands of 38 and 28 Kdaltons in ZR-75-1 cells. As shown in Figure 2c, PC2 mRNA translated into protein products ranging from 73 to 36 Kdaltons with a major form of 36 Kdaltons in MCF-7 cells, but only a single protein band of PC2 immunoreactivity with an approximate size of 20 Kdaltons was demonstrated in ZR-75-1 cells. Combined with the RT-PCR result, this suggests that the gene expression of PC2 in ZR-75-1 is scarce-to-undetectable. Although these enzymes presented slightly different major forms in breast cancer cells, the range of protein forms of PC1/PC3, CPE, PAM in both cell lines, and PC2 in MCF-7 cells are in reasonable agreement with the molecular sizes for each of the enzymes, including their precursors and some active forms reported by others (1, 7, 8, 14, 15, 16, 22, 25, 26). These findings indicate that some biologically active enzyme forms of PC1/PC3, CPE and PAM might be present in both breast cancer cell lines, and of PC2 enzyme in MCF-7 cells.

Discussion

Recent studies have shown that some neuropeptides, such as vasopressin, are not only expressed, but also processed into biologically active forms in breast tumor tissues and cell lines. In the case of vasopressin, strong clinical evidence for such processing by these tumors is provided by the occurrence in some breast cancer patients of the syndrome of inappropriate secretion of antidiuretic hormone (SIADH) (27, 28). Alternatively, our studies indicate that some vasopressin does not undergo processing by breast cancer cells even though they express all known vasopressin receptors (18, 20). Taylor and his coworkers have shown that since changing vasopressin concentrations can significantly influence the cell growth in MCF-7 cells, this peptide is likely to be one of the important modulators of the growth in some human breast carcinomas (20). Since processing enzymes play key roles in processing neuropeptides to biologically active forms, it is then of some interest to discover if these enzymes are not only expressed, but also translated into proteins by breast cancer cells.

Du

PC1/PC3 and PC2 are responsible for the initial cleavage of proteins secreted by the regulated secretory pathway (1, 4, 29, 30, 31), and are primarily expressed in neuronal and endocrine cells (31). Their expression has been demonstrated in small-cell lung cancer cells by us and by others (14, 15, 16). In the current study, not only was PC1/PC3 mRNA shown to be expressed by the two cell lines examined, but this mRNA from both MCF-7 and ZR-75-1 cells was also found to have a sequence identical to that from normal cells (23). Additionally, both cell lines were able to translate mRNA into four major protein forms with appropriate sizes 63, 50, 38 and 30 Kdaltons. At least one of these forms (63 KD) is of a size compatible with that shown to represent functional processing enzyme (1, 16, 26). Previous studies of PC2 gene expression in breast tumor and breast cancer cell lines by Cheng et al (21) and Scopsi et al (16) indicated that PC2 mRNA was not expressed. In agreement with these findings was our failure to demonstrate the presence of this mRNA in ZR-75-1 cells, even though we used primers and PCR conditions with which we successfully amplified PC2 mRNA from small-cell lung cancer cells (15). However, unlike these authors we were able to amplify an 880 bp PC2 cDNA fragment from MCF-7 cells, showing that this mRNA is indeed expressed by some breast cancer cells. Cloning and sequencing of this PC2 cDNA fragment demonstrated it to have 100% sequence homology to the published PC2 mRNA sequence (24). PC2 immunoreactive proteins in MCF-7 cells ranged in sizes from 73 to 36 Kdaltons, with the major form at 36 Kdaltons. The larger forms of these protein products are consistent with active forms of PC2 demonstrated by others (1, 14, 16, 26). Contrary to the apparent absence of the enzyme from ZR-75-1 cells, a protein band of appropriate size of 20 Kdaltons was found by us to be present in these cells by Western analysis. Whether this protein represents a degradation product of active enzyme translated from scarce-to-undetectable levels of mRNA, or a product of antibody cross-reaction with unrelated protein(s), is currently not clear. Nevertheless, our data suggests that while PC2 could be involved in the peptide processing of some breast cancer cells, prohormone convertase activity is more likely to be dependent on PC1/PC3 or other members of this family of enzymes.

The role of carboxypeptidase E (CPE) in the removal of carboxy-terminal basic residues exposed by the endoproteases is generally known to be also necessary for processing of a large number of protein precursors (8). Many biologically active peptides also require being amidated through a processing by peptidylglycine α -amidating monooxygenase (5). These two peptide-processing enzymes are essential for the formation of many neuropeptides, including several with mitogenic effects on tumor cells. Evidence of their expression has been obtained for human lung and pituitary tumors (15, 32, 33, 34). The single products generated through RT-PCR in the present study, and representing CPE or PAM mRNAs of MCF-7 and ZR-75-1 cells, were each of a size predicted from the known structures of the human mRNAs and had normal sequences, in all four cases (8, 22). With respect to CPE, the major protein form demonstrated by Western analysis in both MCF-7 and ZR-75-1 cells, is a 49 Kdaltons product which is consistent with those active forms reported for this enzyme by other sources (8, 15, 25, 35). PAM mRNA was shown through Western analysis, to be translated into one major protein form with an appropriate size of 38 Kdaltons in MCF-7 cells and two protein forms with appropriate sizes of 38 and 28 Kdaltons in ZR-75-1 cells. Although some diversities of PAM expression exist between these two breast cancer cell lines, the major product of 38 Kdaltons in both cell lines, and a minor product of 70 Kdaltons in ZR-75-1 cells are of sizes comparable with active forms of the enzyme in other systems (7, 15).

While no activity studies were performed, the current study along with other studies suggest that breast cancer cells, represented here by MCF-7 and ZR-75-1 cells, are fully capable of generating structurally normal and in some cases presumably functional forms of the key processing enzymes necessary for processing neuropeptide growth factors, such as vasopressin, into biologically active forms. Such enzymes could therefore conceivably represent new and novel targets in future treatments of patients with breast cancer.

Du

Acknowledgements

This work was supported in part by a PHS award from the National Cancer Institute, CA 19613 and an award, DAMD17-94-J-4288, from the Department of Defense. We are thankful to Drs. Main, Eipper, and Fricker for supplying us with antibodies, and for the excellent technical assistance provided by Susan Gagnon, J. Matthew Brennan and Alison North.

References

1. Seidah NG, Chretien M, Day R: The family of subtilisin/kexin like pro-protein and pro-hormone convertases: Divergent or shared functions. *Biochimie* 76: 197-209, 1994
2. Beifeld MC: Prohormone and proneuropeptide processing: recent progress and future challenges. *Endocrine* 8(1): 1-5, 1998
3. Seidah NG, Benjannet S, Pareek S, Savaria D, Hamelin J, Goulet B, Laliverte J, Lazure C, Chretien M, Murphy RA: Cellular processing of the nerve growth factor precursor by the mammalian pro-protein convertases. *Biochem J* 314: 951-960, 1996
4. Steiner DF, Smeekens SP, Ohagi S, Chan SJ: The new enzymology of precursor processing endoproteases. *J Biol Chem* 267: 23435-23438, 1992
5. Steiner DF: The proprotein convertases. *Curr Opin Chem Biol* 2(1): 31-39, 1998
6. Van de Ven WJ, Roebroek AJ, Van Duijnhoven HL: Structure and function of eukaryotic proprotein processing enzymes. *Crit Rev Oncogen* 4: 115-136, 1993
7. Husten EJ, Eipper BA: The membrane-bound bifunctional peptidylglycine α -amidating monooxygenase protein: exploration of its domain structure through limited proteolysis. *J Bio Chem* 266(26): 17004-17010, 1991
8. Manser E, Fernandez D, Loo L, Goh PY, Monfries C, Hall C, Lim L: Human carboxypeptidase E: isolation and characterization of the cDNA, sequence conservation, expression and processing in vitro. *Biochem J* 267: 517-525, 1990
9. Treston AM, Scott FM, Vos M, Iwai N, Mains RE, Eipper BA, Cuttitta F, Mulshine JL: Biochemical characterization of peptide alpha-amidation enzyme activities of human neuroendocrine lung cancer cell lines. *Cell Growth Differ* 4(11): 911-920, 1993
10. Sporn MB, Roberts AB: Autocrine growth factors and cancer. *Nature* 313: 745-747, 1985
11. Creemers JWM, Roebroek AJM, Van de Ven WJM: Expression in human lung tumor cells of the proprotein processing enzyme PC1/PC3: Cloning and primary sequence of a 5 kb cDNA. *FEBS Letters* 300(1): 82-88, 1992

Du

12. Hashimoto K, Kogo M, Kouhara H, Arita N, Hayakawa T, Kishimoto T, Sato B: Expression patterns of messenger ribonucleic acids encoding prohormone convertases (PC2 and PC3) in human pituitary adenomas. *Clin Endocrinol* 41(2): 185-191, 1994
13. Itoh Y, Tanaka S, Takekoshi S, Itoh J, Osamura RY: Prohormone convertases (PC1/3 and PC2) in rat and human pancreas and islet cell tumors: subcellular immunohistochemical analysis. *Pathol Int* 46(10): 726-737, 1996
14. Mbikay M, Sirois F, Yao J, Seidah NG, Chretien M: Comparative analysis of expression of the proprotein convertases furin, PACE4, PC1 and PC2 in human lung tumours. *Br J Cancer* 75(10): 1509-1514, 1997
15. North WG, Du J: Key peptide processing enzymes are expressed by a variant form of small-cell carcinoma of the lung. *Peptides* 19(10): 1743-1747, 1998
16. Scopsi L, Gullo M, Rilke F, Martin S, Steiner DF: Proprotein convertases (PC1/PC3 and PC2) in normal and neuroplastic human tissues: their use as markers of neuroendocrine differentiation. *J Clin Endocrinol Metab* 80(1): 294-301, 1995
17. Bussolati G, Cassoni P, Negro F, Stella A, Sapino A: Effect of oxytocin on breast carcinoma cell growth. *Adv Exp Med Biol* 395: 553-554, 1995
18. North WG, Pai S, Friedmann A, Yu X, Fay M, Memoli V: Vasopressin gene related products are markers of human breast cancer. *Breast Cancer Research and Treatment* 34: 229-235, 1995
19. North WG, Fay MJ, Du J: MCF-7 breast cancer cells express normal forms of all vasopressin receptors plus an abnormal V2R. *Peptides*, in press, 1999
20. Taylor AH, Ang VTY, Jenkins JS, Silverlight JS, Coombes RC, Luqmani YA: Interaction of vasopressin and oxytocin with human breast carcinoma cells. *Cancer Res* 50: 7882-7886, 1990
21. Cheng M, Watson PH, Paterson JA, Seidah N, Chretien M, Shiu RPC: Pro-protein convertase gene expression in human breast cancer. *Int J Cancer* 71: 966-971, 1997

Du

22. Glauder J, Ragg H, Rauch J, Engels JW: Human peptidylglycine alpha-amidating monooxygenase: cDNA, cloning and functional expression of a truncated form in COS cells. *Biochem Biophys Res Commun* 169(2): 551-558, 1990
23. Seidah NG, Hamelin J, Gaspar AM, Day R, Chretien M: The cDNA sequence of the human pro-hormone and pro-protein convertase PC1. *DNA Cell Biol* 11(4): 283-289, 1992
24. Smeekens SP, Steiner DF: Identification of a human insulinoma cDNA encoding a novel mammalian protein structurally related to the yeast dibasic processing protease Kex2. *J Biol Chem* 265(6): 2997-3000, 1990
25. Grimwood BG, Plummer TH Jr, Tarentino AL: Carboxypeptidase H a regulatory peptide-processing enzyme produced by human hepatoma Hep G2 cells. *J Biol Chem* 264(26): 15662-15667, 1989
26. Zhou A, Mains RE: Endoproteolytic processing of proopiomelanocortin and prohormone convertase 1 and 2 in neuroendocrine cells overexpressing prohormone convertases 1 and 2. *J Biol Chem* 269: 17440-17447, 1994
27. Gupta A, Sasarula S, Rao PV: The syndrome of inappropriate secretion of antidiuretic hormone in a case of carcinoma of the breast. *J Assoc Physicians India* 34(6): 441-442, 1986
28. Howard AC, Laing RW, Hussain FN: Breast carcinoma presenting with inappropriate ADH secretion. *Eur J Cancer* 29A(16): 2339, 1993
29. Bruzzaniti A, Goodge K, Jay P, Taviaux SA, Lam MH, Berta P, Martin TJ, Moseley JM, Gillespie MT: PC8 [corrected], a new member of the convertase family. *Biochem J* 314 (3): 727-731, 1996
30. Meerabux J, Yaspo ML, Roebroek AJ, Van de Ven WJ, Lister TA, Young BD: A new member of the proprotein convertase gene family (LPC) is located at a chromosome translocation breakpoint in lymphomas. *Cancer Res* 56(3): 448-451, 1996
31. Seidah NG, Day R, Marcinkiewicz M, Benjannet S, Chretien M: Mammalian neural and endocrine pro-protein and pro-hormone. *Enzyme* 45: 271-284, 1991

Du

32. Saldise L, Martinez A, Montuenga LM, Treston A, Springall DR, Polak JM, Vazquez JJ: Distribution of peptidyl-glycine alpha-amidating mono-oxygenase (PAM) enzymes in normal human lung and in lung epithelial tumors. *J Histochem Cytochem* 44(1): 3-12, 1996
33. Steel JH, Martinez A, Springall DR, Treston AM, Cuttitta F, Polak JM: Peptidylglycine alpha-amidating monooxygenase (PAM) immunoreactivity and messenger RNA in human pituitary and increased expression in pituitary tumours. *Cell Tissue Res* 276(1): 197-207, 1994
34. Vos MD, Scott FM, Iwai N, Treston AM: Expression in human lung cancer cell lines of genes of prohormone processing and the neuroendocrine phenotype. *Cell Biochem Suppl* 24: 257-268, 1996
35. Song L, Fricker LD: Purification and characterization of carboxypeptidase D, a novel carboxypeptidase E-like enzyme, from bovine pituitary. *J Biol Chem* 270(42): 25007-25013, 1995

LEGENDS

Figure 1. Evaluations for human PC1/PC3 from the MCF-7 and ZR-75-1 breast cancer cell lines.

1a. Synthetic primers selected for RT-PCR and sequencing, and predicted PCR product yielded by these primers. 1b. RT-PCR products from a total RNA preparation separated on a 2% agarose gel and visualized with ethidium bromide. Lane 1, 100 bp DNA ladder; lane 2 and 3, 457 bp PC1/PC3 products of expected size obtained from MCF-7 and ZR-75-1 cells, respectively. 1c. Western blot analysis from SDS-PAGE (12%) with an ECL detection system (Amersham) showing proteins with approximate sizes of 63, 50, 38 and 30 Kdaltons immunoreactive with human PC1/PC3 specific antibody from MCF-7 and ZR-75-1 cells, respectively.

Figure 2. Evaluations for human PC2 from the MCF-7 and ZR-75-1 breast cancer cell lines. 2a.

Synthetic primers selected for RT-PCR and sequencing, and predicted PCR product yielded by these primers. 2b. RT-PCR products from a total RNA preparation separated on a 2% agarose gel and visualized with ethidium bromide. Lane 1, 100 bp DNA ladder; lane 2, 880 bp PC2 product of expected size obtained from MCF-7 cells, and lane 3, PC2 specific PCR product was not amplified in ZR-75 cells with the conditions we and others have applied. 2c. Western blot analysis from SDS-PAGE (12%) with an ECL detection system (Amersham) showing proteins with approximate sizes of 73, 55, and 36 Kdaltons immunoreactive with human PC2 specific antibody from MCF-7, and a 20 Kdaltons protein product from ZR-75-1 cells, respectively.

Figure 3. Evaluations for human CPE from the MCF-7 and ZR-75-1 breast cancer cell lines. 3a.

Synthetic primers selected for RT-PCR and sequencing, and predicted PCR product yielded by these primers. 3b. RT-PCR products from a total RNA preparation separated on a 2% agarose gel and visualized with ethidium bromide. Lane 1, 100 bp DNA ladder; lane 2 and 3, 405 bp CPE products of expected size obtained from MCF-7 and ZR-75-1 cells, respectively. 3c. Western blot analysis from SDS-PAGE (12%) with an ECL detection system (Amersham) showing a major

Du

protein product with an approximate size of 49 Kdaltons immunoreactive with human CPE specific antibody from MCF-7 and ZR-75-1 cells, respectively.

Figure 4. Evaluations for human PAM from the MCF-7 and ZR-75-1 breast cancer cell lines. 4a. Synthetic primers selected for RT-PCR and sequencing, and predicted PCR product yielded by these primers. 4b. RT-PCR products from a total RNA preparation separated on a 2% agarose gel and visualized with ethidium bromide. Lane 1, 100 bp DNA ladder; lane 2 and 3, 560 bp PAM products of expected size obtained from MCF-7 and ZR-75-1 cells, respectively. 4c. Western blot analysis from SDS-PAGE (12%) with an ECL detection system (Amersham) showing a dominant protein form with an approximate size of 38 Kdaltons immunoreactive with human PAM specific antibody from MCF-7, and proteins with appropriate sizes of 70, 55, 50, 38 and 28 Kdaltons from ZR-75-1 cells, respectively.

OXYTOCIN DOES NOT INDUCE A RISE IN INTRACELLULAR FREE
CALCIUM IN HUMAN BREAST CANCER CELLS

Michael J. Fay,^{1,*} Jinlin Du,² Kenneth A. Longo,² and William G. North²

Department of Pharmacology,¹ Midwestern University, 555 31st Street
Downers Grove, IL 60515 and
Department of Physiology,² Dartmouth Medical School,
1 Medical Center Drive, Lebanon, NH 03756.

Abstract

Research suggests that oxytocin acts as a growth modulating agent for breast cancer cells. However, the signaling mechanisms responsible for these modulatory effects have not been fully elucidated. In the physiological setting oxytocin is known to stimulate contraction of myometrial cells in the uterus and myoepithelial cells in the breast by increasing intracellular free calcium ($[Ca^{2+}]_i$). The expression of oxytocin receptor mRNA in T-47D breast cancer cells, and four additional breast cancer cell lines (BT-549, MCF-7, MDA-MB- 231, ZR-75-1), was confirmed by RT-PCR analysis. Oxytocin-induced changes in $[Ca^{2+}]_i$ in indo-1 AM loaded T-47D breast cancer cells were monitored using flow cytometric analysis. In this cell line, oxytocin (0, 1, 10, 100, and 1,000 nM) did not induce a dose-dependent increase in the mean 405nm/485nm emission ratio. These results indicate that oxytocin signaling in T-47D breast cancer cells does not appear to involve an increase in $[Ca^{2+}]_i$.

Introduction

Oxytocin is a nine amino acid hormone that is produced as a pro-hormone by magnocellular neurons in the para-ventricular and supraoptic nuclei of the hypothalamus. The oxytocin pro-hormone is packaged into neurosecretory vesicles where it is acted upon by processing enzymes, resulting in the production of active hormone and oxytocin-associated neurophysin. An appropriate physiological stimuli results in the release of oxytocin and oxytocin-associated neurophysin from the axonal terminals of these neurons which are located in the posterior pituitary. The major physiological actions of oxytocin include stimulating the contraction of myometrial cells in the uterus and myoepithelial

* Author for correspondence, Email: mfayxx@midwestern.edu Phone: (630) 515-6382; Fax: (630) 971-6414.

cells in the breast. These actions of oxytocin are important in the physiological processes of parturition and milk letdown (for review see Gainer and Wray, 1994).

The physiological effects of oxytocin occur as a result of hormone binding to cell surface oxytocin receptors. The cloned oxytocin receptor belongs to the family of 7-transmembrane G-protein coupled receptors (Kimura, Tanizawa *et al.*, 1992). Research indicates that the myometrial oxytocin receptor couples through heterotrimeric G-proteins containing G α _q/G α ₁₁ or G α _h to stimulate phospholipase C activity (Ku, Qian *et al.*, 1995; Baek, Kwon *et al.*, 1996). Activation of phospholipase C results in the subsequent production of the second messengers inositol triphosphate (IP3) and diacylglycerol (DAG), which play important roles in the release of calcium from intracellular stores and the activation of protein kinase C. The oxytocin receptor also appears capable of coupling to heterotrimeric G-proteins containing other G α subunits (e.g. G α _i and G α _s), suggesting that the activated oxytocin receptor may initiate additional intracellular signaling events (Strakova and Soloff, 1997).

Human breast cancer cell lines and biopsy samples express oxytocin receptor mRNA and protein (Taylor, Ang *et al.*, 1990; Cassoni, Sapino *et al.*, 1994; Bussolati, Cassoni *et al.*, 1995; Ito, Kobayashi *et al.*, 1996; Sapino, Cassoni *et al.*, 1998). In addition, several reports indicate that oxytocin can modulate the growth of breast cancer cells (Taylor, Ang *et al.*, 1990; Cassoni, Sapino *et al.*, 1994; Cassoni, Sapino *et al.*, 1996; Cassoni, Sapino *et al.*, 1997; Sapino, Cassoni *et al.*, 1998). However, the signaling mechanisms involved in the oxytocin-induced growth modulation of breast cancer cells have not been fully elucidated. The purpose of this research was to verify the expression of oxytocin receptors in T-47D breast cancer cells and other breast cancer cell lines, and to determine if oxytocin induces a rise in [Ca²⁺]_i in the T-47D breast cancer cell line.

Materials and Methods

Cell Culture

The BT-549 (ATCC HTB 122), MCF-7 (ATCC HTB 22), MDA-MB-231 (ATCC HTB 26), T-47D (ATCC HTB 133), and ZR-75-1 (ATCC CRL 1500) breast cancer cell lines were obtained from the American type culture collection (ATCC, Rockville, MD). Cells were cultured according to ATCC recommended guidelines. The BT-549, MDA-

MB-231, and MCF-7 cells were maintained in Dulbecco's modified Eagle's medium (Sigma Chemical Co., St. Louis, MO) supplemented with 10% fetal bovine serum (Hyclone Laboratories, Logan, UT), while the T-47D and ZR-75-1 cell lines were maintained in RPMI-1640 medium (Sigma Chemical Co., St. Louis, MO) supplemented with 10% fetal bovine serum (Hyclone Laboratories, Logan, UT). Every 2 - 3 days, the cells either received fresh growth medium or were sub-cultured using 0.25% trypsin with 0.03% EDTA. Prior to calcium analysis, the cells were placed in serum-free medium overnight containing 0.1% bovine albumin (fraction V; Sigma Chemical Co., St. Louis, MO).

Flow Cytometric Analysis of $[Ca^{2+}]_i$

To examine oxytocin-induced changes in $[Ca^{2+}]_i$ ratio-metric analysis was performed using indo-1 AM loaded cells and flow cytometry (Grynkiewicz, Poenie *et al.*, 1985). The T-47D cells were removed from the culture flasks using a non-enzymatic cell dissociation solution (Sigma Chemical Co., St. Louis, MO). The cells were pelleted, counted, and 2×10^6 cell/ml were placed in serum-free RPMI 1640 medium containing 5 μ M indo-1 AM (Molecular Probes Inc., Eugene, OR). Cells were incubated with the indo-1 AM for 45 min. at 37° C. and were then washed twice with phosphate buffered saline (PBS) and re-suspended at 1×10^5 cells/ml in PBS (containing ~ 1 mM calcium chloride) supplemented with 1 mg/ml glucose and 1 mg/ml BSA (Sigma Chemical Co., St. Louis, MO). The re-suspended cells were kept on ice until flow cytometric analysis was performed. Approximately 5 - 10 min. prior to analysis a 1.0 ml aliquot of cells (~ 10^5 cells total) was placed at 37° C. Analysis was performed using a Facstar plus flow cytometer (Becton Dickinson, San Jose, CA). Cells were excited at 356 nm, and emission monitored at 405 nm (calcium bound indo), and at 485 nm (unbound indo), and each sample was analyzed for approximately 4 min. Oxytocin (Calbiochem, San Diego, CA) was administered to the cell sample after approximately 25 sec. of baseline to give final concentrations of 0 nM, 1 nM, 10 nM, 100 nM, and 1,000 nM. As a positive control, a final concentration of 10 μ M 4-bromo A23187 (Molecular Probes, Inc., Eugene, OR) was administered to the cells for 5 min. at 37° C prior to analysis. Data was analyzed using Lysis II software (Becton Dickinson, San Jose, CA), and plotted as the mean ratio (405nm/485nm) vs. time (sec.).

RNA Isolation

Poly (A)+ RNA isolation was performed using the technique of oligo(dT) cellulose chromatography (Badley, Bishop *et al.*, 1988). Briefly, cells (10^8 /10 ml of lysis buffer) were disrupted using lysis buffer (0.2 M NaCl, 0.2 M Tris HCl pH 7.5, 1.5 mM MgCl₂, 2% SDS, and 200 µg/ml proteinase K), and DNA was sheared by passing the lysate several times through 18 and 23 gauge needles. Lysates were then incubated at 45° C for 2 hours. Oligo(dT) cellulose (Boehringer Mannheim, Indianapolis, IN) was prepared by hydrating 0.2 g of the resin in elution buffer (0.01M tris-HCl pH 7.5), pelleting (500 rpm), and washing twice in binding buffer (0.5 M NaCl, 0.01 M Tris-HCl pH 7.5). The NaCl concentration was adjusted to 0.2 M, and lysates were then added to the oligo(dT) cellulose. After a 20 min. incubation at room temp, the oligo(dT) cellulose was pelleted, and washed several times with fresh binding buffer. Samples were then loaded onto poly-prep columns (BIO-RAD Labs., Hercules, CA), and RNA was eluted using two 0.5 ml volumes of elution buffer (0.01 M Tris-HCl pH 7.5). Precipitated RNA was quantified by determining the absorbance at 260 nm.

RT-PCR and Restriction Enzyme Analysis

Reverse transcription-polymerase chain reaction (RT-PCR), using the Perkin Elmer GeneAmp® RNA PCR kit (Roche Molecular Systems, Inc., Branchburg, NJ), was used to determine expression of oxytocin receptor mRNA in BT-549, MCF-7, MDA-MB-231, T-47D, and ZR-75-1 breast cancer cell lines. First strand cDNA synthesis was performed using 4 µg of poly (A)+ RNA in a mixture (20 µl total volume) containing 5 mM MgCl₂, 1x PCR buffer II, 1 mM of each dNTP (dGTP, dATP, dTTP, dCTP), 1 U/µl RNase inhibitor, 2.5 U/µl MuLV reverse transcriptase, and 2.5 µM Oligo d(T). The conditions used for the reverse transcription were 10 min. at room temp followed by 15 min. at 42° C, and 5 min. at 99° C. The PCR mixture (50 µl total volume) consisted of 10 µl of the reverse transcription reaction, 200 nM of each oxytocin receptor primer (see below), 2 mM MgCl₂, 1x PCR buffer II, and 1.25 U of Amplitaq® DNA polymerase. Oxytocin receptor PCR reactions were performed using the following conditions: 97° C for 2 min. and 30 cycles that included 30 sec. at 95° C, 1 min. 30 sec. at 58° C, 1 min. 30 sec. at 72° C, and a final extension step at 72° C for 10 min. The PCR products were

electrophoresed for 1 hour at 100 volts using a 2.0 % agarose gel and TAE buffer. A 100 bp DNA ladder (Gibco BRL, Gaithersburg, MD) was used to determine the size of the amplified products and the gel was stained with ethidium bromide to visualize the DNA using a UV trans-illuminator. The oxytocin receptor primers are based on the sequence of the cloned human oxytocin receptor (Kimura, Tanizawa *et al.*, 1992), and amplify a 391 base pair product. The sequence of these primers is as follows: forward primer (base pairs 1215 - 1234)

5'-CCTTCATCGTGTGCTGGACG-3', reverse primer (base pairs 1586 - 1605)

5'-CTAGGAGCAGAGCACTTATG-3'. To verify the identity of the generated PCR product a restriction digest was performed on approximately 0.25 µg of purified DNA with 15 U of Pvu II (Stratagene, La Jolla, CA) for 1.5 hours at 37° C.

Results

Flow Cytometric Analysis of $[Ca^{2+}]_i$

As shown in Figure 1, oxytocin at all of the doses tested (0 nM, 1 nM, 10 nM, 100 nM, and 1,000 nM) did not appear to cause a dose-dependent rise in $[Ca^{2+}]_i$ in the T-47D breast cancer cell line. In both controls and oxytocin-treated cells there did appear to be transient changes in the 405 nm/485 nm emission ratio, however these transients were not characteristic of the rapid initial rise in $[Ca^{2+}]_i$ followed by a sustained plateau phase that has been observed after oxytocin receptor activation (Anwer and Sanborn, 1989; Tasaka, Masumoto *et al.*, 1991; Seitz, Cooper *et al.*, 1993; Arnaudeau, Lepretre *et al.*, 1994). Proper loading of the cells with indo-1 AM was confirmed by treating cells with the calcium ionophore 4-bromo A23187, which resulted in an increase in the 405 nm/485 nm emission ratio for the T-47D breast cancer cells (see graph F of Figure 1). Identical results were obtained for duplicate independent experiments with the T-47D cell line and the same dosages of oxytocin. Preliminary results obtained with the ZR-75-1 breast cancer cell line also showed that oxytocin at doses ranging from 0 - 1,000 nM did not cause a rise in $[Ca^{2+}]_i$ (data not shown).

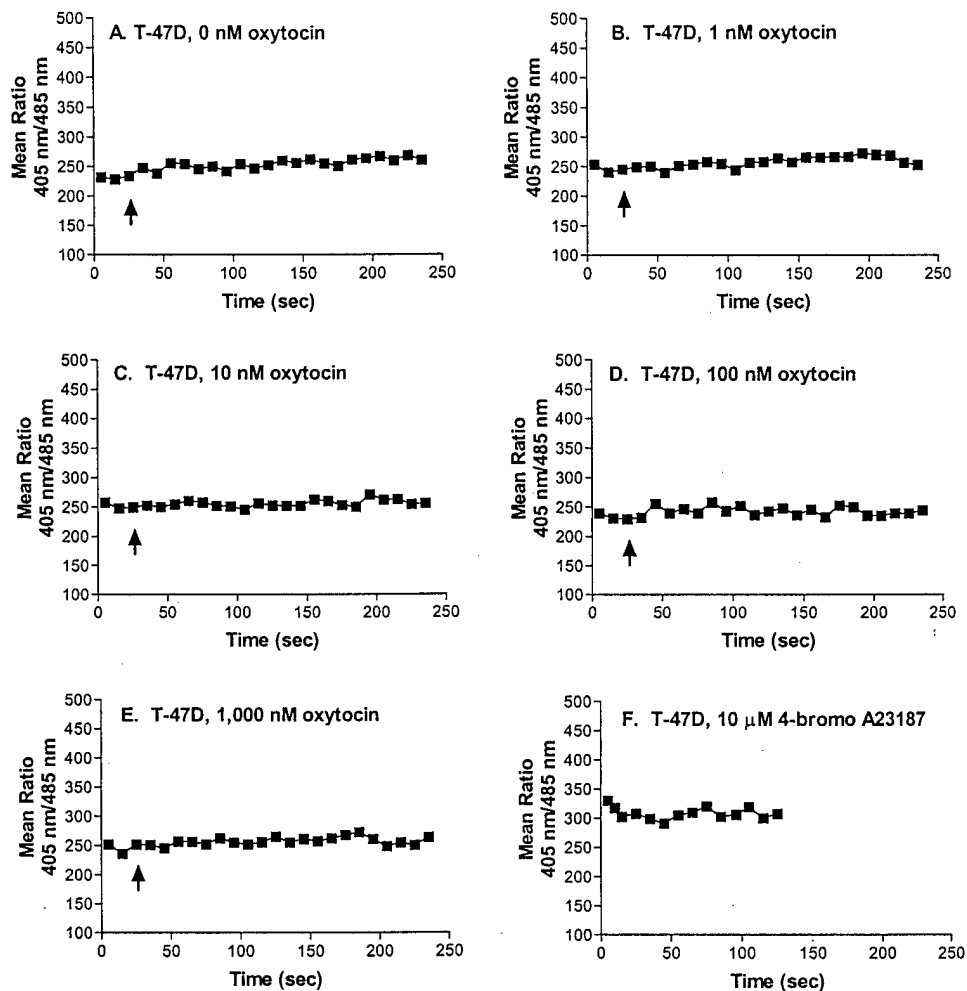

Figure 1. Influence of oxytocin on intracellular free calcium levels in T-47D breast cancer cells. The T-47D breast cancer cells were loaded with indo-1AM and oxytocin-induced changes in intracellular free calcium were measured using flow cytometric analysis to determine the 405 nm/485 nm emission ratio over a 4 min. period. After approximately 25 sec. of baseline, samples were injected with either PBS or oxytocin to give hormone concentrations of 0 nM (Figure 1A), 1 nM (Figure 1B), 10 nM (Figure 1C), 100 nM (Figure 1D), and 1,000 nM (Figure 1E). As a positive control the calcium ionophore 4-bromo A23187 was added to the samples at a final concentration of 10 μM (Figure 1F).

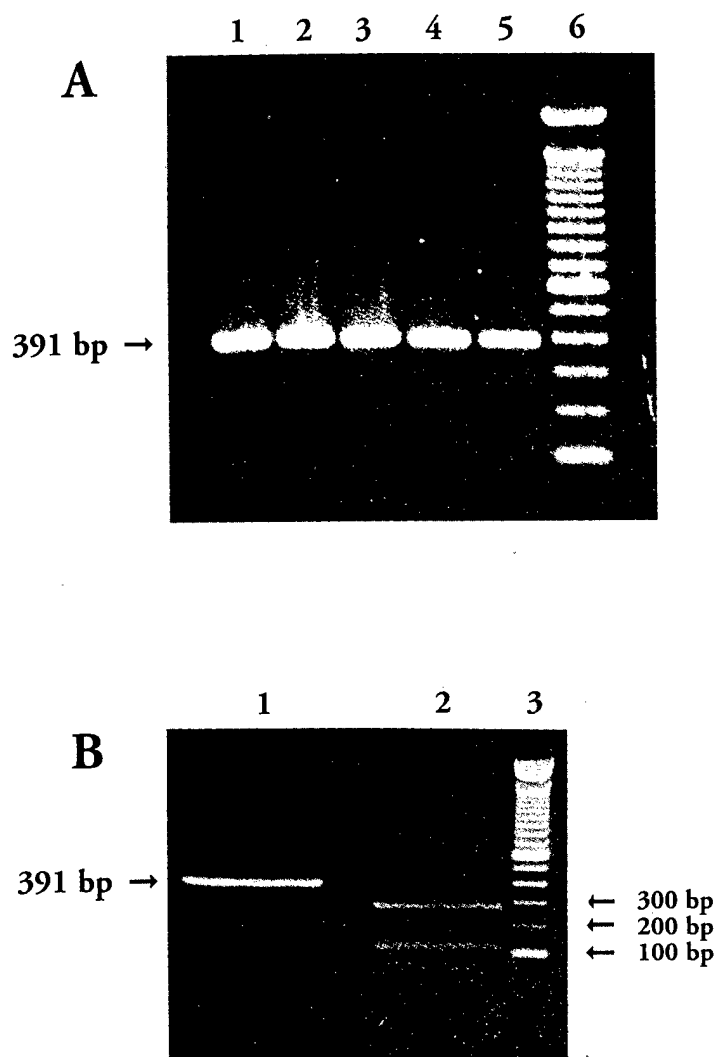

Figure 2. (A) RT-PCR analysis of oxytocin receptor mRNA expression in breast cancer cell lines. Lane 1: BT-549 cell line; Lane 2: MCF-7 cell line; Lane 3: MDA-MB-231 cell line; Lane 4: T-47D cell line; Lane 5: ZR-75-1 cell line; Lane 6: 100 bp DNA ladder. The 391 bp oxytocin receptor PCR product was amplified from all of the cell lines. (B) The 391 bp PCR product was subjected to restriction enzyme digestion with Pvu II. When no enzyme was present the 391 bp PCR product remains intact (Lane 1). With the addition of Pvu II the generation of 118 bp and 273 bp DNA products was evident (Lane 2).

RT-PCR and Restriction Enzyme Analysis

As illustrated in Figure 2A, a PCR product of the predicted size of 391 base pairs (bp) was amplified from all of the breast cancer cell lines examined. The oxytocin receptor primers chosen for PCR span a 12-kb intron of the human oxytocin receptor

gene (Inoue, Kimura *et al.*, 1994), thus PCR amplification from genomic DNA contamination of the RNA samples can be ruled out. The RT-PCR results are representative of duplicate or triplicate independent experiments. In samples in which water was used instead of RNA in the initial reverse transcription reaction the 391 bp product was not amplified during PCR (data not shown). To further confirm the identity of the oxytocin receptor PCR product restriction enzyme digestion of the purified PCR product was performed. Using the restriction enzyme Pvu II the 391 base pair oxytocin receptor PCR product was cleaved to products of the predicted sizes of 118 and 273 base pairs (see Figure 2B).

Discussion

It is well established that breast cancer cells express oxytocin receptor mRNA and protein. Using the techniques of RT-PCR and Northern blot analysis, a number of researchers (Cassoni, Sapino *et al.*, 1994; Bussolati, Cassoni *et al.*, 1996; Ito, Kobayashi *et al.*, 1996; Sapino, Cassoni *et al.*, 1998) have demonstrated the expression of oxytocin receptor mRNA in cultured human breast cancer cell lines and breast cancer biopsy specimens. In agreement with these previous findings, we have demonstrated the expression of oxytocin receptor mRNA using the technique of RT-PCR in five human breast cancer cell lines. Radio-ligand binding has been used to demonstrate the presence of high affinity binding sites for oxytocin on MCF-7 breast cancer cells (Taylor, Ang *et al.*, 1990). The expression of oxytocin receptor protein by breast cancer cells has also been confirmed using Western blot analysis and immuno-chemical techniques to stain cultured breast cancer cells and archival biopsy specimens (Bussolati, Cassoni *et al.*, 1996; Ito, Kobayashi *et al.*, 1996; Sapino, Cassoni *et al.*, 1998). Using the technique of immunohistochemistry we have demonstrated that archival breast cancer specimens exhibit positive staining for oxytocin, but not for the neurophysin portion of the oxytocin prohormone (North, Pai *et al.*, 1995). These results suggest receptor-mediated uptake of hormone by the oxytocin receptor as opposed to ectopic production of oxytocin by the breast cancer cells.

Even though breast cancer cell lines express oxytocin receptors, the exact role of activated oxytocin receptors in relation to the differentiation and pathophysiology of

breast cancer has not been clearly established. Murrell (1995) hypothesized that oxytocin may prevent breast cancer by stimulating the contraction of myoepithelial cells and thereby assisting the elimination of carcinogens from the breast. A number of research studies have been published which demonstrate a growth promoting effect of oxytocin on breast cancer cells, a growth inhibiting effect of oxytocin on breast cancer cells, and no measurable effect of oxytocin on breast cancer cell growth. In one study using MCF-7 breast cancer cells, Taylor, Ang *et al.* (1990) demonstrated that oxytocin (10 pM - 1 nM) stimulated the growth of these cells when treated over a 7 day period. Contrary to these results, several studies have shown that oxytocin and the oxytocin analogue F314 inhibit the growth of breast cancer cells *in vitro* and *in vivo* (Cassoni, Sapino *et al.*, 1994; Cassoni, Sapino *et al.*, 1997; Sapino, Cassoni *et al.*, 1998). The maximum growth inhibitory effect of oxytocin (34%) observed by these authors was seen with the treatment of MDA-MB-231 breast cancer cells with 100 nM oxytocin for 6 days (Cassoni, Sapino *et al.*, 1994). Of interest is the finding that even in breast cancer cell lines that were not significantly growth inhibited by oxytocin alone, this peptide hormone was still able to enhance tamoxifen-induced growth inhibition and attenuate estradiol-induced growth promotion (Cassoni, Sapino *et al.*, 1994). Research performed by Ito, Kobayashi *et al.* (1996) demonstrated no effect of oxytocin (1nM - 100 nM) on the growth of MCF-7, MDA-MB-231, MDA-MB-361, and MDA-MB-468 breast cancer cell lines that were treated with hormone over a seven day period. These apparent discrepancies concerning the influence of oxytocin on breast cancer cell growth may reflect differences in culture conditions, different concentrations of peptide, intrinsic differences in the cell lines, and phenotypic changes that may occur in cultured cells over time.

Activated oxytocin receptors play a role in stimulating the contraction of myometrial cells in uterus and myoepithelial cells in the breast, which is important for the processes of parturition and milk-letdown, respectively. These physiological actions of oxytocin involve G-protein coupling to phospholipase C resulting in the generation of IP3 and a subsequent rise in $[Ca^{2+}]_i$. In both uterine myometrial and breast myoepithelial cells, this rise in intracellular-free calcium involves a release of calcium from intracellular stores and an influx of extracellular calcium (Anwer and Sanborn, 1989; Tasaka, Masumoto *et*

al., 1991; Seitz, Cooper *et al.*, 1993; Arnaudeau, Lepretre *et al.*, 1994). The initial rapid rise in $[Ca^{2+}]_i$ after oxytocin administration is mainly attributed to a release of calcium from intracellular stores and the subsequent sustained rise (plateau phase) in $[Ca^{2+}]_i$ is attributed to an influx of calcium from outside the cell. In two cultured breast cancer cell lines

(T-47D and ZR-75-1) we observed no oxytocin-induced rise in $[Ca^{2+}]_i$, as evidenced by a lack of initial spike or latter sustained plateau, using indo-1 AM loaded cells and flow cytometric analysis. In agreement with the present findings, Cassoni, Sapino *et al.*, (1997) demonstrated by microscopy that fura-2 loaded MDA-MB-231 breast cancer cells did not demonstrate a rise in $[Ca^{2+}]_i$ after treatment with oxytocin (1 nM – 100 nM). The present findings and those of Cassoni, Sapino *et al.*, (1997) suggest that oxytocin-signaling in breast cancer cells appears to be different when compared to activated oxytocin receptors in the physiological setting and does not appear to involve a rise in $[Ca^{2+}]_i$. This raises the question what is the signaling pathway for oxytocin in breast cancer cells? Cassoni, Sapino *et al.*, (1997) have demonstrated an association between the growth inhibitory effect of oxytocin on MDA-MB-231 cells and an increase in the second messenger cAMP. Such an association is in accordance with the growth inhibiting effects that cAMP has on breast cancer cells (Cho-Chung and Gullino *et al.*, 1974; Tagliaferri, Katsaros *et al.*, 1988; Starzec, Spanakis *et al.*, 1994; Vintermyr, Boe *et al.*, 1995). It is of interest to note that in addition to raising $[Ca^{2+}]_i$, an oxytocin-induced increase in cAMP has also been observed in breast myoepithelial cells (Olins and Bremel, 1984; Seitz, Cooper *et al.*, 1993), although the accumulation of cAMP did not appear to be associated with myosin phosphorylation (Olins and Bremel, 1984). How oxytocin is increasing cAMP levels in breast cancer cells remains unanswered. One possibility involves the activation of adenylate cyclase by coupling of the oxytocin receptor to a heterotrimeric G-protein containing $G_{\alpha s}$, since all adenylate cyclases appear to be activated by this G-protein sub-unit (Birnbaumer and Birnbaumer, 1995). The coupling of the oxytocin receptor to heterotrimeric G-proteins containing $G_{\alpha s}$ in breast cancer cells seems possible in light of recent findings demonstrating that oxytocin receptors from rat myometrium can couple to $G_{\alpha s}$ (Strakova and Soloff, 1997). Another possible scenario is that, as in endometrial and amnion cells, oxytocin may increase production of

prostaglandins in breast cancer cells (Asselin, Drolet *et al.*, 1997; Burns, Tsai *et al.*, 1997; Strakova, Copland *et al.*, 1998). An oxytocin-induced production of prostaglandins in breast cancer cells could result in an indirect increase in cAMP by binding of prostaglandins to specific prostaglandin receptors on the cancer cells in an autocrine or paracrine fashion. Research findings indicate that both prostaglandins and oxytocin can inhibit breast cancer growth by mechanisms associated with cAMP accumulation (Planchon, Veber *et al.*, 1995; Cassoni, Sapino *et al.*, 1997), indicating a possible interaction between these two substances in breast cancer growth inhibition. Another possibility includes the interaction of oxytocin with other hormone receptors, such as the vasopressin V₂ receptor, that couple through adenylate cyclase to increase cAMP levels.

In conclusion, the influence of the hormone oxytocin on signaling events in breast cancer cells does not appear to involve changes in [Ca²⁺]_i. It is of interest to note that normal breast epithelial cells, the cells believed to give rise to most breast cancers, have recently been shown to express oxytocin receptors (Kimura, Ito *et al.*, 1998). The role of oxytocin receptor expression and activation with regards to the growth and differentiation of normal breast epithelial cells and breast cancer cells warrant further investigation.

Acknowledgments

The authors would like to thank Dr. Alice Givan and Mr. Gary Ward for assistance with the flow cytometric calcium analysis, and Ms. Susan Gagnon and Ms. Alison North for technical assistance. This work was supported in part by Department of Defense grants DAMD 17-94-J-4131 (M.J.F.) and DAMD 17-94-J-4288 (W.G.N.). Michael J. Fay was also supported by startup funds from Midwestern University. Flow cytometric analyses were performed at Dartmouth Medical School in the Herbert C. Englert Cell Analysis Laboratory, which was established by a grant from the Fannie E. Rippel Foundation and is supported in part by the Core Grant of the Norris Cotton Cancer Center (CA 23108).

References

- Anwer, K. and Sanborn, B.M. (1989). Changes in intracellular free calcium in isolated myometrial cells: role of extra-cellular and intracellular calcium and possible involvement of guanine nucleotide-sensitive proteins. *Endocrinol.* 124: 17-23.
- Arnaudeau, S., Lepretre, N. and Mironneau, J. (1994). Oxytocin mobilizes calcium from a unique heparin-sensitive and thapsigargin-sensitive store in single myometrial cells from pregnant rats. *Pflugers Arch.* 428: 51-59.

- Asselin, E., Drolet, P. and Fortier, M.A. (1997). Cellular mechanisms involved during oxytocin-induced prostaglandin $F_{2\alpha}$ production in endometrial epithelial cells in vitro: role of cyclooxygenase-2. *Endocrinol.* 138: 4798-4805.
- Badley, J.E., Bishop, G.A., St. John, T. and Frelinger, J.A. (1988). A simple, rapid method for the purification of poly A+ RNA. *Biotechniques* 6: 114-116.
- Baek, K.J., Kwon, N.S., Lee, H.S., Kim, M.S., Muralidhar, P. and Im, M-J. (1996). Oxytocin receptor couples to the 80 kDa G_{ha} family protein in human myometrium. *Biochem. J.* 315: 739-744.
- Birnbaumer, L. and Birnbaumer, M. (1995). Signal transduction by G proteins: 1994 edition. *J. Recept. Signal Transduct. Res.* 15: 213-252.
- Burns, P.D., Tsai, S-J., Wiltbank, M.C., Hayes, S.H., Graf, G.A. and Silvia, W.J. (1997). Effect of oxytocin on concentrations of prostaglandin H synthetase-2 mRNA in ovine endometrial tissue in vitro. *Endocrinol.* 138: 5637-5640.
- Bussolati, G., Cassoni, P., Ghisolfi, G., Negro, F. and Sapino, A. (1995). Immunolocalization and gene expression of oxytocin receptors in carcinomas and non-neoplastic tissues of the breast. *Am. J. Pathol.* 148: 1985-1903.
- Cassoni, P., Sapino, A., Negro, F. and Bussolati, G. (1994). Oxytocin inhibits proliferation of human breast cancer cell lines. *Virchows Archiv* 425: 467-472.
- Cassoni, P., Sapino, A., Papotti, M., and Bussolati, G. (1996). Oxytocin and oxytocin-analogue F314 inhibit cell proliferation and tumor growth of rat and mouse mammary carcinomas. *Int. J. Cancer* 66: 817-820.
- Cassoni, P., Sapino, A., Fortunati, N., Munaron, L., Chini, B. and Bussolati, G. (1997). Oxytocin inhibits the proliferation of MDA-MB231 human breast cancer cells via cyclic adenosine monophosphate and protein kinase A. *Int. J. Cancer* 72: 340-344.
- Cho-Chung, Y.S. and Gullino, P.M. (1974). *In vivo* inhibition of growth of two hormone-dependent mammary tumors by dibutyryl cyclic AMP. *Science* 183: 87-88.
- Gainer, H. and Wray, S. (1994). Cellular and molecular biology of oxytocin and vasopressin. In: *The Physiology of Reproduction*. Edited by Knobil, E. and Neil, J.D. Raven Press, Ltd, New York, NY USA. pp. 1099-1129.
- Grynkiewicz, G., Poenie, M. and Tsien, R.Y. (1985). A new generation of Ca^{2+} indicators with greatly improved fluorescence properties. *J. Biol. Chem.* 260: 3440-3450.
- Inoue, T., Kimura, T., Azuma, C., Inazawa, J., Takemura, M., Kikuchi, T., Kubota, Y., Ogita, K. and Saji, F. (1994). Structural organization of the human oxytocin receptor gene. *J. Biol. Chem.* 51: 32451-32456.
- Ito, Y., Kobayashi, T., Kimura, T., Matura, N., Wakasugi, E., Takeda, T., Shimano, T., Kubota, Y., Nobunaga, T., Makino, Y., Azuma, C., Saji, F. and Monden, M. (1996). Investigation of the oxytocin receptor expression in human breast cancer tissue using newly established monoclonal antibodies. *Endocrinol.* 137: 773-779.

- Kimura, T., Tanizawa, O., Mori, K., Brownstein, M.J. and Okayama, H. (1992). Structure and expression of a human oxytocin receptor. *Nature* 356: 526-529.
- Kimura, T., Ito, Y., Einspainer, A., Tohya, K., Nobunaga, T., Tokugawa, Y., Takemura, M., Kubota, Y., Ivell, R., Matsuura, N., Saji, F. and Murata, Y. (1998). Expression and immunolocalization of the oxytocin receptor in human lactating and non-lactating mammary glands. *Human Reproduction* 13: 2645-2653.
- Ku, C., Qian, A., Wen, Y., Anwer, K. and Sanborn, B.M. (1995). Oxytocin stimulates myometrial guanosine triphosphatase and phospholipase-C activities via coupling to $G\alpha_q/11$. *Endocrinol.* 136: 1509-1515.
- Murrell, T.G.C. (1995). The potential for oxytocin (OT) to prevent breast cancer: A hypothesis. *Breast Cancer Research and Treatment* 35: 225-229.
- North, W.G., Pai, S., Friedmann, A., Yu, X., Fay, M. and Memoli, V. (1995). Vasopressin gene related products are markers of human breast cancer. *Breast Cancer Research and Treatment* 34: 229-235.
- Planchon, P., Veber, N., Magnien, V., Israel, L. and Starzec, A.B. (1995). Alteration of prostaglandin E receptors in advanced breast cancer cell lines. *Mol. Cell. Endocrinol.* 111: 219-223.
- Sapino, A., Cassoni, P., Stella, A. and Bussolatti, G. (1998). Oxytocin receptor within the breast: Biological function and distribution. *Anticancer Res.* 18: 2181-2186.
- Seitz, P.K., Cooper, K.M., Ives, K.L., Ishizuka, J., Townsend, C.M., Rajaraman, S. and Cooper, C.W. (1993). Parathyroid hormone-related peptide production and action in a myoepithelial cell line derived from normal human breast. *Endocrinol.* 133: 1116-1124.
- Starzec, A.B., Spanakis, E., Nehme, A., Salle, V., Veber, N., Maignuene, C., Planchon, P., Valette, A., Prevost, G. and Israel, L. (1994). Proliferative responses of epithelial cells to 8-bromo-Cyclic AMP and to phorbol ester change during breast pathogenesis. *J. Cell. Physiol.* 161: 31-38.
- Strakova, Z. and Soloff, M.S. (1997). Coupling of oxytocin receptor to G proteins in rat myometrium during labor: G_i receptor interaction. *Am. J. Physiol.* 272: E870-E876.
- Strakova, Z., Copland, J.A., Lolait, S.J. and Soloff, M.S. (1998). ERK2 mediates oxytocin-stimulated PGE_2 synthesis. *Am. J. Physiol.* 274: E634-E641.
- Tagliaferri, P., Katsaros, D., Clair, T., Ally, S., Tortora, G., Neckers, L., Rubalcava, B., Parandoosh, Z., Chang, Y.A., Revankar, G.R., Crabtree, G.W., Robins, R.K. and Cho-Chung, Y.S. (1988). Synergistic inhibition of growth of breast and colon cancer cell lines by site-selective cyclic AMP analogues. *Cancer Res.* 48: 1642-1650.
- Tasaka, K., Masumoto, N., Miyake, A. and Tanizawa, O. (1991). Direct measurement of intracellular free calcium in cultured human puerperal myometrial cells stimulated by oxytocin: effects of extra-cellular calcium and calcium channel blockers. *Obstetrics and Gynecol.* 77: 101-106.

- Taylor, A.H., Ang, V.T.Y., Jenkins, J.S., Silverlight, J.J., Coombes, R.C. and Luqmani, Y.A. (1990). Interaction of vasopressin and oxytocin with human breast carcinoma cells. *Cancer Res.* 50: 7882-7886.
- Vintermyr, O.K., Boe, R., Brustugun, O.T., Maronde, E., Aakvaag, A. and Doskeland, S.O. (1995). Cyclin adenosine monophosphate (cAMP) analogs 8-Cl-and 8-NH₂-cAMP induce cell death independently of cAMP kinase-mediated inhibition of the G1/S transition in mammary carcinoma cells (MCF7). *Endocrinol.* 136: 2513-2520.

COPYRIGHT © 1999 BY
PJD PUBLICATIONS LIMITED, P.O. BOX 966, WESTBURY, NY 11590



TISSUE SPECIFIC EXPRESSION OF HVACM/CUL-5, A CULLIN PROTEIN, IN HUMANS

Kenneth A. Longo^{1,4*}, Michael J. Fay², Vincent A. Memoli³, and William G. North¹

Department of ¹Physiology and ³Pathology, Dartmouth Medical School, 1 Medical Center Drive, Lebanon, NH 03755, U.S.A. Department of ²Pharmacology, Midwestern University, Downers Grove, IL 60515. ⁴Department of Physiology, University of Michigan Medical School, Ann Arbor, MI, 48109.

*To whom correspondence and reprint requests should be addressed: Department of Physiology, University of Michigan Medical School, 1301 E. Catherine Rd, Ann Arbor, MI 48109-0622. Tel: (734) 647-7721; Fax: (734) 936-8813.

Summary

HVACM, also known as Cul-5, is a member of the cullin protein family. Cullins are involved in the ubiquitin-mediated degradation of cell cycle proteins, but the precise function(s) of Cul-5, a protein that interacts with the hormone vasopressin, is unknown. We developed polyclonal antibodies against this protein, and looked for Cul-5 expression in AMeX-processed normal human tissues. Cul-5 is expressed intracellularly in kidney distal convoluted tubule, skeletal muscle capillary endothelial cells, ^{and} Kupffer cells of the liver, ~~and by cells inhabiting the germinal centers of lymph nodes.~~ Cul-5 is not expressed by normal human lung which is interesting given that Cul-5 was cloned from a human lung cancer cell line. It is concluded that Cul-5 is an intracellular protein that is expressed by several human cell types, and may play roles in skeletal muscle vascular physiology, kidney physiology, and immune cell function.

None in controls

Introduction

The human vasopressin-activated calcium-mobilizing receptor (HVACM) was cloned from a human small cell lung carcinoma (SCLC) cell line (Longo, Fay et al. 1998), and has recently been renamed Cul-5. The Cul-5 cDNA (GenBank accession number AF017061) encodes a putative protein of 780 amino acids, with a predicted molecular weight of 91 kD. Cul-5 can interact specifically with vasopressin (AVP), which promotes intracellular calcium mobilization. However, Cul-5 is structurally distinct from the AVP V_{1a} receptor subtype: Cul-5 contains no predicted transmembrane domain (Longo, Fay et al. 1998). The V_{1a} receptor contains seven transmembrane domains, is G-protein-linked, and is also capable of promoting intracellular calcium mobilization in response to AVP stimulation through a mechanism that involves inositol triphosphate (Howl, Ismail et al. 1991; Nathanson, Moyer et al. 1992; Thibonnier, Auzan et al. 1994).

Cul-5 is homologous to the cullins, a relatively new family of proteins, which are involved in the ubiquitin-mediated degradation of cell cycle proteins (Kipreos, Lander et al. 1996; Byrd, Stankovic et al. 1997; Longo, Fay et al. 1998). The function of Cul-5 is unknown, although its considerable C-terminal homology to the cullins suggests that it too may be involved in ^{in a similar role.} ~~ubiquitin-mediated cell cycle protein~~ degradation (Longo, Fay et al. 1998). The nuclear cullin protein Cdc53, which has orthologues expressed in yeast and humans, interacts specifically with the ubiquitin ligase Cdc34 and the F-box protein Cdc4 (Feldman, Correll et al. 1997). Together, these proteins direct the ubiquitination of the G₁/S phase transition regulatory protein Sic1 (Mathias, Johnson et al. 1996; Verma, Feldman et al. 1997). Cdc53 has no catalytic activity, and is believed to act as a scaffolding protein for the assembly of the ubiquitin ligase complex (Patton, Willems et al. 1998). In this capacity, Cdc53 (and other cullins) may partially determine the substrate specificity, and hence the

functional specificity, of ubiquitin ligase complexes (Kipreos, Lander et al. 1996; Willems, Lanker et al. 1996). The growing number of cullin family proteins in humans suggests that different cullins may be involved in different ubiquitination events (Kipreos, Lander et al. 1996). Therefore, an analysis of the tissue-specific expression of Cul-5 might provide clues as to the function of this protein in humans.

Cul-5-specific polyclonal antibodies were prepared by immunizing rabbits with a synthetic peptide representing the N-terminal 15 amino acids of Cul-5, conjugated to keyhole limpet hemocyanin. Analysis of Cul-5 expression in various AMeX-processed normal human tissues was evaluated by immunohistochemistry. The normal human tissues lung, kidney, liver, lymph node, and skeletal muscle were fixed immediately after biopsy by the AMeX method, which is thought to preserve the antigenicity of cellular proteins (Kiernan 1990).

Positive staining for Cul-5 was noted in capillary endothelial cells of skeletal muscle, cells comprising the distal convoluted tubules of the kidney, Kupffer cells inhabiting the liver sinusoids, and cells inhabiting the germinal centers of lymph nodes (which are presumably lymphocytes undergoing antigenic challenge and differentiation in mature lymphocytes). *However, lymph node staining was discovered to be a false positive.*

Of interest was the apparent absence of staining of human lung epithelium, or lung capillary endothelium, but a positive staining of immune cell types such as polymorphonuclear (PMN) cells, occupying the alveolar spaces. Positive staining of PMNs in the lung was also noted with pre-immune antibodies, and when anti-Cul-5 antibodies were pre-incubated with the Cul-5 peptide immunogen. The staining of PMN cells was further investigated using flow cytometric analysis of isolated peripheral blood lymphocytes, monocytes, and PMNs. These experiments confirmed that PMN staining occurred with equal intensity using either the anti-Cul-5 antibodies, or pre-immune antibodies.

*It didn't stain the cells of
lymph node staining
system?*

done by [unclear]

These results indicate that Cul-5 may be playing roles in the vascular physiology of skeletal muscle, as well as in the physiology of the distal convoluted tubules of the kidney. Furthermore, Cul-5 appears to be expressed in maturing lymphocytes of the lymph nodes, as well as in Kupffer cells, which are macrophages endogenous to the liver, suggesting that Cul-5 may influence myelopoiesis or immune cell function. Cul-5, which was cloned from human SCLC, was not observed in lung tissue, suggesting that SCLC does not arise from lung tissue proper, but rather from cells of myeloid origin (Ruff and Pert 1984).

Materials and methods

Development of polyclonal antibodies directed against an Cul-5 epitope

Cul-5-specific polyclonal antibodies were prepared by and purchased from Bio-Synthesis, Inc. (Lewisville, TX). Two New Zealand White rabbits were immunized with a synthetic peptide of the following amino acid sequence: MATSNLLKNKGSQFC. (This sequence comprises the amino terminal 15 amino acids of the putative Cul-5 protein.) The peptide was conjugated to the carrier protein keyhole limpet hemocyanin via a sixteenth C-terminal cysteine residue on the peptide. Rabbit serum antibody titers were assessed using an ELISA-based assay. When titers were satisfactory, the rabbits were sacrificed and their blood collected by cardiac puncture, and antibody-rich supernatant, or serum, was collected and stored at -20° C. For this study, antibodies in serum were purified using a protein A-Sepharose column (Ausubel, Brent et al. 1988). Specificity of the antibodies for Cul-5 was confirmed using Western blot analysis of cellular protein lysates from COS-7 cells over-expressing the cloned Cul-5.

Tissue Preparation

All normal tissues used in these studies were obtained from the Pathology Department at the Dartmouth Hitchcock Medical Center, Lebanon, NH, and represented the following tissues: lung, liver, kidney, lymph node, and skeletal muscle. All tissues were fixed by the AMeX (Acetone, Methyl benzoate, Xylene) method (Sato, Mukai et al. 1986). Following fixation, the tissues were embedded in paraffin wax, sliced into 4 μ m sections, and mounted on silane-coated glass slides. Tissues on slides were de-paraffinized by initially baking the slides in 60° C oven for 20 min, followed by four submersions in 100% Xylene, for 5 min each. The slides were then dipped in acetone 20 times, and washed with ddH₂O for 2 min.

Immunohistochemistry

Endogenous peroxidase activity was removed from de-paraffinized tissues by immersion in a 0.3% peroxide solution for 20 min, followed by washing with ddH₂O, and then PBS buffer. This was followed by ~~washing~~ ^{trypsinization} with 95% ethanol, and rinsing with PBS buffer. Human Fc receptors were blocked by addition of 100 μ l of human IgG in PBS buffer (1 mg/ml), incubated for 20 min at room temperature, and then rinsed with PBS buffer. The primary antibodies (either anti-Cul-5 or pre-immune IgGs) were prepared in stock solutions of 1 mg/ml in PBS buffer containing 0.1% sodium azide, and were utilized at dilutions of 1:400 in PBS buffer containing 10% goat serum, and the tissues were incubated for 12-18 h at 4°C. (Antibody dilutions were initially tested ranging from 1:50 to 1:1600. A dilution of 1:400 of protein A-purified antibodies was deemed optimal on the basis of contrast staining between anti-Cul-5 antibodies and pre-immune antibodies.) The following day the antibodies were removed by washing with PBS buffer at room temperature. A solution of biotinylated secondary goat anti-rabbit antibody was applied to each section and incubated for 30 min. Following washing of the secondary antibody with PBS buffer ABC solution (avidin-biotin-horseradish peroxidase, Ventana

Medical Systems, Tucson, AZ) was added to each section for 30 min. Non-bound peroxidase was removed by washing with PBS buffer. Visualization of staining ~~was~~ ^{CEM} performed by addition of a 3,3' diaminobenzidine (DAB) for 8 min, rinsed ^{ing} with PBS buffer, counterstained ^{ing} with Hematoxylin, rinsed ^{ing} with PBS buffer, washed ^{ing} with xylene, and coverslipped ^{ing} with Aquamount.

Flow cytometric analysis of HVACM expression in PMNs

Peripheral blood cells (lymphocytes, monocytes, and PMNs) isolated using a Ficoll gradient, washed with PBS buffer containing 0.1% bovine albumin serum (BSA), ^g Fraction V). Cells were stained for Cul-5 intracellularly. ~~The cells were fixed~~ ^{by fixing them} in PBS buffer containing 1% PFA for 30 min, on ice, and then permeabilized ^{ing} with staining buffer (PBS buffer containing 1% BSA, 0.1% sodium azide, and 0.3% saponin). Anti Cul-5 antibodies or pre-immune antibodies were diluted in staining buffer (final concentration of antibodies: 0.4 µg/ml). The cells were incubated in the presence of antibodies for 15 min, on ice, washed with staining buffer, stained with goat anti-rabbit-FITC (Life Technologies, Gaithersburg, MD), and finally washed again with staining buffer. ^{Fluorescence was evaluated} ~~The cells were analyzed~~ with a Becton Dickinson FACScan five parameter flow cytometer. Cul-5 expression was analyzed by laser-stimulated FITC excitation (495 nm) and detected emission (519 nm). Expression of Cul-5 was gauged against pre-immune antibodies by comparison of histograms of fluorescence intensity.

SDS-polyacrylamide gel electrophoresis (PAGE) and Western blot analysis

Protein lysates from COS-7 cells over-expressing Cul-5 were separated by 10% SDS-PAGE at 75 V for 2.5 h at room temperature in a Tris-glycine buffer (25 mM Tris-base, pH 8.3, 192 mM glycine, 0.1% SDS) (Laemmli 1970; Ausubel, Brent et al. 1988). The gels were rinsed briefly with distilled water, and proteins were transferred to a

methanol-activated Imobilon-P membrane (0.45 μm porosity) (Millipore Inc., Bedford, MA) at 15 V, 18 h, ^{and} at 4 °C in a Tris-glycine buffer (20 mM Tris-base, pH 8.0, 15 mM glycine) containing 20% methanol (Towbin, Staehelin et al. 1979).

Immunoblotting with anti-Cul-5 antibodies

Following Western transfer, the Imobilon-P membranes were blocked in blocking buffer (10 mM Tris-HCl, pH 7.3, 100 mM NaCl, 0.1% Tween-20, 5% non-fat dried milk) for 1 h at room temperature. Cul-5 antibodies (10 μg) were diluted in 5 ml of blocking buffer and added to the membrane for 15 min, followed by repeated washes with wash buffer (10 mM Tris-HCl, pH 7.3, 100 mM NaCl, 0.1% Tween-20). Specific Cul-5 antibodies were detected by incubation of the membrane with goat anti-rabbit-horse radish peroxidase-conjugated secondary antibody (Life Technologies, Gaithersburg, MD) diluted 1:20,000 in blocking buffer for 30 min at room temperature, repeated rinsing with wash buffer, and visualization using enhanced chemiluminescence (ECL) (Amersham, Piscataway, NJ).

Results

Characterization of Cul-5 antibodies

Anti-Cul-5 polyclonal antibodies detected two proteins of molecular sizes ~95 kD and ~50 kD in cell lysates of COS-7 cells over-expressing Cul-5 (Fig. 9) by SDS-PAGE and Western blot analysis. The pre-immune antibodies did not detect any proteins, indicating the specificity of the anti-Cul-5 antibodies. Pre-incubation of the anti-Cul-5 antibodies with the immunizing peptide successfully blocked the staining of these two bands (data not shown).

Kidney Cul-5 expression

Positive staining of this tissue appeared to be localized exclusively to the distal convoluted tubules (Fig. 1). ^{Tubules} This staining was intracellular, and no membrane staining, either apical or basolateral, was noted. No other tubular segments or ~~regions~~ regions of the kidney demonstrated positive staining for Cul-5. *and endothelial cells -*

Liver Cul-5 expression

Positive staining of liver was localized exclusively to cells inhabiting the liver sinusoids (Fig. 2). These cells were identified as Kupffer cells, macrophages that normally reside in the hepatic sinusoids. No other cells types within the liver demonstrated any staining for Cul-5.

Skeletal muscle Cul-5 expression

Positive staining of skeletal muscle was visualized in the endothelial cells comprising capillaries of this tissue (Fig. 3). This staining was intracellular, and was successfully blocked when anti-Cul-5 antibodies were incubated with tissues in the presence of a 10-fold molar excess of the immunizing peptide (data not shown). Some mild positive staining of the sarcomeres is also apparent.

Lymph node Cul-5 expression

Positive staining of the lymph nodes was localized to cells residing within the germinal centers of the nodes (Fig. 4). These cells, with their high cytoplasm-to-nucleus ratios, are most likely T- and B-lymphocytes undergoing antigenic challenge. No positive staining was evident in cells with little or no cytoplasm, located in the areas surrounding the germinal centers. These cells are presumably small lymphocytes that are resting in a pre-blast state, and have not yet undergone antigenic challenge. *However, preimmune serum gave the same staining pattern demonstrating that the staining was produced by antibody was not specific, or that staining was produced by passive hemolysis activity*

Lung Cul-5 expression

Initial evaluation of lung tissue stained with anti-Cul-5 antibodies revealed no staining of the alveolar epithelium, or of endothelial cells comprising capillary vessels scattered throughout the tissue (~~Fig. 5~~). Pronounced positive staining of cells attached to the alveolar surface was observed. These cells were determined to be polymorphonuclear (PMN) cells, based on the multi-lobulated with no nuclear staining. Staining appeared to be cytoplasmic, and excluded from the nuclei. In some cases, staining of subcellular granules was noted. However, both the pre-immune controls (~~Fig. 6~~) and antigen-blocked controls (~~Fig. 7~~) also stained normal lung tissue in a similar fashion, indicating that staining of these cells was most likely an artifact due to either endogenous peroxidase activity that could not be successfully removed during tissue treatment with peroxide, or a failure to properly block F_c receptors located on these cells.

Western on Cos cells in Figure 4

Flow cytometric analysis of Peripheral Blood Cells

Both anti-Cul-5 antibodies and pre-immune antibodies stained PMN cells with equal fluorescence intensity in flow cytometry performed on PMNs, confirming an absence of specific Cul-5 antibody/Cul-5 protein interactions, and confirming the false-positive results from immunohistochemistry of the lung (~~Fig. 9~~). (Data not shown)

Discussion

Immunohistochemical localization of Cul-5 to the distal convoluted tubule in human kidney corroborates evidence found for the rabbit VACM-1 receptor, which was cloned from, and immunolocalized to cells comprising the rabbit kidney distal convoluted tubule (Burnatowska-Hledin, Spielman et al. 1995). The

significance of Cul-5 expression in the distal convoluted tubule is not clear, since no explicit function has yet been attributed to this protein (Byrd, Stankovic et al. 1997; Longo, North et al. 1997). However, results obtained in the current studies differ from those obtained for the rabbit, VACM-1 staining was reported to be basolateral (Burnatowska-Hledin, Spielman et al. 1995), while Cul-5 seems to be expressed intracellularly, with no apical or basolateral localization. Possible explanations for this apparent difference between VACM-1 and Cul-5 localization may be the tissue preparation method employed, or observational variance. VACM-1 immunohistochemistry in rabbit kidneys was performed on frozen tissue sections using immunofluorescence, while the studies reported here were performed on AMeX-processed tissues. The possibility that AMeX fixation altered the cellular localization of Cul-5, however minute, cannot be ruled out.

The staining of Kupffer cells within hepatic sinusoids raises the intriguing possibility that Cul-5 may be involved in the activities of liver macrophages. The hypothesized role of Cul-5 in ubiquitin-mediated degradation of cellular proteins, and the lability of Kupffer cells to small vasoactive peptides (Alexander 1998), begs the question of whether or not Cul-5, and AVP, have cell-specific function in Kupffer cells. Kupffer cells are modified macrophages that originate in the bone marrow, and migrate to the sinusoids of the liver, where they differentiate into their final phenotype (Bouwens 1988; Naito, Hasegawa et al. 1997). Kupffer cells carry out typical macrophage duties like the clearance of IgA- and IgG-bacterial complexes (Bogers, Stad et al. 1992), as their macrophage phenotype would suggest, but also participate in several pathophysiologic processes of the liver (Cerra, West et al. 1988). During bacterial sepsis (endotoxic shock), ischemia, and injury, Kupffer cells synthesize and release the free radical nitric oxide (NO) (Alexander 1998). At low levels, NO is both bactericidal, as well as tumoricidal (Evans 1995; Alexander 1998). However, at higher levels, NO is toxic to the liver (Evans 1995). Prolonged

stimulation or hyper-stimulation of Kupffer cells can lead to free-radical induced destruction of the liver (Cerra, West et al. 1988), despite the cytoprotective effects of antioxidants secreted by the endothelial cells lining the liver sinusoids (Moro, Jacoulet et al. 1994; Spolarics 1998). Liver necrosis in response to alcohol abuse is the indirect result of alcohol-induced release of endotoxins from bacteria in the gut, which stimulate the production and release of liver-damaging NO (as well as eicosanoids and tumor necrosis factor-alpha) from Kupffer cells (Thurman, Bradford et al. 1997). Conversely, Kupffer cells have profound effects on liver regeneration through their production of the hormone Hepatocyte Growth Factor (HGF) (Matsumoto and Nakamura 1991), and in response to pro-inflammatory cytokines (Diehl and Rai 1996). Kupffer cells also are a major producer of metalloproteinases, which may be important in liver restructuring following injury or necrosis, or which could possibly induce necrosis in some pathophysiological states (Arthur 1994). Whether or not Cul-5 plays a role in any of these processes is unknown.

The vasopressin receptor subtype V_{1a} is expressed in liver hepatocytes, and AVP-stimulation of these cells increases glycogen phosphorylase activity (Diehl and Rai 1996). The role of AVP in the hepatocyte function of humans appears to be relatively minor when compared to that of the rat. In rat liver, AVP stimulates profound increases in glycogen phosphorylase activity, as well as in DNA synthesis (Howl, Ismail et al. 1991). AVP can evoke increases in $[Ca^{2+}]_i$ in hepatocytes located in the pericentral regions of the liver, and these Ca^{2+} "waves" propagate out into the periportal regions of the liver (Nathanson, Burgstahler et al. 1995). The ability of VACM-1 (and by inference Cul-5) to evoke increases of $[Ca^{2+}]_i$ in response to AVP, in conjunction with the V_{1a} receptor's established role in hepatic Ca^{2+} homeostasis, paints a more complex picture of how AVP may be affecting liver Ca^{2+} metabolism and function (Burnatowska-Hledin, Spielman et al. 1995; Longo, Fay et al. 1998).

Altogether
The selective positive staining for Cul-5 found in the germinal center of lymph nodes suggests that Cul-5 may play a role in the maturation or function of lymphocytes or macrophages that occupy the germinal centers. Several lines of evidence suggest that AVP can modulate cell-mediated immunity, and can influence the maturation of several immune cell types, and that these effects are mediated by several AVP receptor subtypes (Bell, Adler et al. 1992). AVP is released from the posterior pituitary in response to different forms of immune stress, in addition to its release in response to low osmolality or fluid loss (Bell, Adler et al. 1992). Macrophages express AVP receptors, and AVP stimulates cAMP production in these cells (Bell, Adler et al. 1993). Induction of interferon-gamma (IFN γ) production in mouse spleen cells through a V₁-type cGMP-dependent mechanism has also been demonstrated (Johnson, Farrar et al. 1982; Johnson and Torres 1985; Elands, Resink et al. 1990). Vasopressin V₁ receptor agonists and antagonists were able to stimulate and block, respectively, IFN γ production in splenic lymphocytes, while vasopressin V₂ receptor agonists and antagonists had no effect (Johnson and Torres 1988; Torres and Johnson 1988). AVP stimulates peripheral PMNs and B-cells to produce β -endorphin (Kavelaars, Ballieux et al. 1989). Several immune cells types, ranging from splenic plasma cells and immature lymphocytes, to immune support cells like the thymic nurse cells (which are responsible for controlling the development and differentiation of immature T-cells within the thymus) are also influenced by AVP (Hammer and Skagen 1986; Liard 1986; Wiles, Grant et al. 1986). In its capacity as an AVP-binding protein, ^{Therefore} Cul-5 may be involved in some of the AVP-responsive physiologic phenomena observed in immune cells (Longo, Fay et al. 1998).

Endothelial cells comprising the capillary walls of skeletal muscle express Cul-5. No positive staining of capillary endothelial cells was noted in any of the other tissues studied, indicating that Cul-5 localization to capillaries was specific to

*did not appear to be
specific*

nevertheless

*through its association
with
vasopressin*

the endothelial cells of skeletal muscle alone. AVP can reduce blood flow in skeletal muscle, as well as in skin (Hammer and Skagen 1986; Liard 1986; Wiles, Grant et al. 1986). Whether these effects are mediated through the classical AVP receptors, or through Cul-5, is unclear, since none of these studies tested the effects V₁ or V₂ receptor agonists or antagonists on blood flow (Hammer and Skagen 1986; Liard 1986; Wiles, Grant et al. 1986).

More intriguing is the role of AVP in the morphogenic differentiation of skeletal muscle cells. Cultures of L6 myoblasts, treated with 1 μ M AVP demonstrated an increase in myotube size, without cell division (Nervi, Benedetti et al. 1995). This effect was blocked by treatment of cells with AVP in the presence of a V₁ receptor antagonist (Nervi, Benedetti et al. 1995). AVP-induced expression of the muscle-specific transcription factor Myf-5 and the muscle-specific protein myogenin was also noted (Nervi, Benedetti et al. 1995). AVP-induced skeletal muscle differentiation may be mediated through the stimulation of phospholipase D (Naro, Donchenko et al. 1997). Given its proposed role as a cullin, Cul-5 may be partly responsible for catabolic processes (i.e. protein degradation) that are essential for AVP-induced skeletal muscle growth and differentiation.

Initial immunohistochemical evaluation of normal human lung indicated that Cul-5 was expressed in cells attached to the alveolar surface, but not in lung epithelial cells, or in lung capillary endothelial cells. Cul-5-expressing cells were evaluated to be PMNs, based on their multi-lobulated nuclear morphology.

However, positive staining was also apparent in both the pre-immune controls and ^{antigen} peptide controls employed in immunohistochemistry, indicating that staining of these PMNs was probably non-specific. This non-specific staining for Cul-5 was confirmed by flow cytometry on peripheral blood cells (PMNs, macrophages, and lymphocytes) stained with anti-Cul-5 antibodies. Evaluation of Cul-5 expression by Western Analysis confirmed that Cul-5 protein was absent from peripheral blood

the Cul-5 staining of muscle is weak and maybe non-specific

cells. This raises an interesting question: if neither lung epithelial cells or endothelial cells, nor immune cells inhabiting the alveolar spaces of the lung, express HVACM, then why is this protein expressed in an SCLC cell line (Longo, Fay et al. 1998)? (Conversely, why do Kupffer cells express Cul-5 protein, while their systemic and alveolar counterparts do not?) A transformed lung PMN might abnormally express this protein, whereas the precursor, untransformed cell, might not. The abnormal expression of Cul-5 in these tumors may be explained by the high frequency of chromosomal abnormalities found in the Cul-5 locus on human chromosome 11q22-23 in lung and breast tumors (Carter, Negrini et al. 1994; Rasio, Negrini et al. 1995; Tomlinson, Strickland et al. 1995; Kerangueven, Eisinger et al. 1997). It is also possible that this particular lung tumor did not originate in the lung at all, but rather from a transformed cell type that migrated to the lung. ~~Since Cul-5 appears to be expressed in activated monocytes and lymphocytes in lymph nodes, it is possible that the SCLC cell line NCI-H146 originated from either alveolar macrophages or lymphocytes, or transformed macrophages and lymphocytes that migrated to the lung (Ruff and Pert 1984; Ruff and Pert 1987). Lung tumors, in particular SCLC tumors, may originate from alveolar macrophages, several SCLC tumors exhibit both neuroendocrine and immune cell features, traits that are entirely consistent with the cell line NCI-H146 (Koros, Bey et al. ; Ruff and Pert 1984; North 1991). Moreover, alveolar macrophages become cytochemically altered in smokers and SCLC patients (Berman and Goldman 1992), suggesting that smoke-induced differentiation of macrophages, cells which are normally capable of movement between tissues by extravasation/intravasation, might produce tumor cells with an inherent ability to "metastasize."~~ ^{this is because}

FIGURE LEGENDS

³
Figs. 1-4. Positive Cul-5 intracellular immunostaining of distal convoluted tubule (D) cells (Fig. 1), Kupffer cells (K) in hepatic sinusoids (Fig. 2), ^{and} capillary endothelial cells (C) in skeletal muscle (Fig. 3), and lymphocytes (L) inhabiting the germinal centers of lymph node (Fig. 4). No positive immunostaining was noted with pre-immune antibody controls, or antigen-blocked antibody controls, for the above tissues.

Figs. 5-7. Positive Cul-5 intracellular immunostaining of immune cells in the alveolar spaces of normal human lung (Fig. 5). Positive staining was also observed in pre-immune control tissue (Fig. 6), and antigen-blocked antibody control tissue (Fig. 7), suggesting that anti-Cul-5 antibodies were non-specifically interacting with these cells.

Fig. 8. Flow cytometric histograms of peripheral blood immune cells (monocytes, lymphocytes, and polymorphonuclear cells) stained with anti-Cul-5 antibodies (A) and pre-immune antibodies (B). The similar flow cytometric staining profiles with these two antibodies corroborate the non-specific staining noted in immunohistochemistry of the lung (Figs. 5-7).

⁴
Fig. 9. Characterization of Cul-5 rabbit polyclonal antibodies. Cell lysates from COS-7 cells over-expressing Cul-5 were subjected to SDS-PAGE and Western blotting, and immunoblotted with either pre-immune antibodies (PI) or anti-Cul-5 antibodies (α -Cul-5), and a secondary anti-rabbit-HRP antibody. Two protein bands of approximate molecular sizes 95 kD and 50 kD were visualized using anti-Cul-5 antibodies. These two proteins were not detected with the pre-immune control lane

Acknowledgments

This work was supported by National Institutes of Health Grant CA-19613 and Department of Defense Grant DAMD 17-94-J-4288. Michael Fay was supported by the NIH training grant T32DK07508 and the DOD fellowship DAMD 17-94-J-4131. Kenneth Longo was supported by generous grants from the Dolores Zhorhab Liebmann Foundation and the Stephen J. Ryan Foundation.

REFERENCES

- Alexander, B. (1998). "The role of nitric oxide in hepatic metabolism." Nutrition 14(4): 376-90.
- Arthur, M. J. (1994). "Degradation of matrix proteins in liver fibrosis." Pathol Res Pract 190(9-10): 825-33.
- Ausubel, F. M., R. Brent, R. E. Kingston, D. D. Moore, J. G. Seidman, J. A. Smith and K. Struhl (1988). Current Protocols in Molecular Biology. NY, Wiley-Interscience.
- Bell, J., M. W. Adler and J. I. Greenstein (1992). "The effect of arginine vasopressin on the autologous mixed lymphocyte reaction." Int J Immunopharmacol 14(1): 93-103.
- Bell, J., M. W. Adler, J. I. Greenstein and L. Y. Liu-Chen (1993). "Identification and characterization of [125I]arginine vasopressin binding sites on human peripheral blood mononuclear cells." Life Sci 52(1): 95-105.
- Berman, D. M. and W. F. Goldman (1992). "Stored calcium modulates inositol phosphate synthesis in cultured smooth muscle cells." 263: C535-C539.
- Bogers, W. M., R. K. Stad, L. A. Van Es and M. R. Daha (1992). "Both Kupffer cells and liver endothelial cells play an important role in the clearance of IgA and IgG immune complexes." Res Immunol 143(2): 219-24.
- Bouwens, L. (1988). "Structural and functional aspects of Kupffer cells." Revis Biol Celular 16: 69-94.
- Burnatowska-Hledin, M. A., W. S. Spielman, W. L. Smith, P. Shi, J. M. Meyer and D. L. Dewitt (1995). "Expression cloning of an AVP-activated, calcium-mobilizing receptor from rabbit kidney medulla." Am J Physiol 268(6 Pt 2): F1198-210.
- Byrd, P. J., T. Stankovic, C. M. McConville, A. D. Smith, P. R. Cooper and A. M. Taylor (1997). "Identification and analysis of expression of human VACM-1, a

cullin gene family member located on chromosome 11q22-23 [letter]." Genome Research 7(1): 71-5.

Carter, S. L., M. Negrini, R. Baffa, D. R. Gillum, A. L. Rosenberg, G. F. Schwartz and C. M. Croce (1994). "Loss of heterozygosity at 11q22-q23 in breast cancer." Cancer Research 54(23): 6270-4.

Cerra, F. B., M. West, G. Keller, J. Mazuski and R. L. Simmons (1988). "Hypermetabolism/organ failure: the role of the activated macrophage as a metabolic regulator." Prog Clin Biol Res 264: 27-42.

Diehl, A. M. and R. Rai (1996). "Review: regulation of liver regeneration by pro-inflammatory cytokines." J Gastroenterol Hepatol 11(5): 466-70.

Elands, J., A. Resink and E. R. De Kloet (1990). "Neurohypophyseal hormone receptors in the rat thymus, spleen, and lymphocytes." Endocrinology 126(5): 2703-10.

Evans, C. H. (1995). "Nitric oxide: what role does it play in inflammation and tissue destruction?" Agents Actions Suppl 47: 107-16.

Feldman, R. M., C. C. Correll, K. B. Kaplan and R. J. Deshaies (1997). "A complex of Cdc4p, Skp1p, and Cdc53p/cullin catalyzes ubiquitination of the phosphorylated CDK inhibitor Sic1p [see comments]." Cell 91(2): 221-30.

Hammer, M. and K. Skagen (1986). "Effects of small changes of plasma vasopressin on subcutaneous and skeletal muscle blood flow in man." Acta Physiol Scand 127(1): 67-73.

Howl, J., T. Ismail, A. J. Strain, C. J. Kirk, D. Anderson and M. Wheatley (1991). "Characterization of the human liver vasopressin receptor. Profound differences between human and rat vasopressin-receptor-mediated responses suggest only a minor role for vasopressin in regulating human hepatic function." Biochem J 276(Pt 1): 189-95.

Johnson, H. M., W. L. Farrar and B. A. Torres (1982). "Vasopressin replacement of interleukin 2 requirement in gamma interferon production: lymphokine activity of a neuroendocrine hormone." J Immunol 129(3): 983-6.

Johnson, H. M. and B. A. Torres (1985). "Regulation of lymphokine production by arginine vasopressin and oxytocin: modulation of lymphocyte function by neurohypophyseal hormones." J Immunol 135(2 Suppl): 773s-775s.

Johnson, H. M. and B. A. Torres (1988). "A novel arginine vasopressin-binding peptide that blocks arginine vasopressin modulation of immune function." J Immunol 141(7): 2420-3.

- Kavelaars, A., R. E. Ballieux and C. J. Heijnen (1989). "The role of IL-1 in the corticotropin-releasing factor and arginine- vasopressin-induced secretion of immunoreactive beta-endorphin by human peripheral blood mononuclear cells." J Immunol 142(7): 2338-42.
- Kerangueven, F., F. Eisinger, et al. (1997). "Loss of heterozygosity in human breast carcinomas in the ataxia telangiectasia, Cowden disease and BRCA1 gene regions." Oncogene 14(3): 339-47.
- Kiernan, J. (1990). Histological and Histochemical Methods: Theory and Practice. Oxford, England, Pergamon Press.
- Kipreos, E. T., L. E. Lander, J. P. Wing, W. W. He and E. M. Hedgecock (1996). "cul-1 is required for cell cycle exit in *C. elegans* and identifies a novel gene family." Cell 85(6): 829-39.
- Koros, A. M., E. A. Bey, S. L. Conley and B. W. Rogers "Phenotypic differences among morphologically similar small-cell carcinomas detected with a panel of monoclonal antibodies and indirect immunofluorescence and flow cytometry." International Journal of Cancer - Supplement 1994;8:127-31.
- Laemmli, U. K. (1970). "Cleavage of structural proteins during the assembly of the head of bacteriophage T4." Nature 227: 680-685.
- Liard, J. F. (1986). "Effects of intra-arterial arginine-vasopressin infusions on peripheral blood flows in conscious dogs." Clin Sci 71(6): 713-21.
- Longo, K., M. Fay, J. Du and W. North (1998). "Small-cell lung cancer expresses a functional form of VACM-1, a putative vasopressin receptor and cullin family member." Cancer Research: In submission. ?
- Longo, K. A., W. G. North, J. Du and M. J. Fay (1997). "Evidence for the expression of a novel vasopressin-activated calcium mobilizing receptor (HVACM) in human breast cancer and human lung cancer cell lines." World Congress of Neurohypophyseal Hormones.
- Mathias, N., S. L. Johnson, M. Winey, A. E. Adams, L. Goetsch, J. R. Pringle, B. Byers and M. G. Goebel (1996). "Cdc53p acts in concert with Cdc4p and Cdc34p to control the G1-to-S- phase transition and identifies a conserved family of proteins." Mol Cell Biol 16(12): 6634-43.
- Matsumoto, K. and T. Nakamura (1991). "Hepatocyte growth factor: molecular structure and implications for a central role in liver regeneration." J Gastroenterol Hepatol 6(5): 509-19.

- Moro, D., P. Jacoulet, et al. (1994). "Small cell lung cancer: patients surviving longer than thirty months." Anticancer Research 14: 301-304.
- Naito, M., G. Hasegawa and K. Takahashi (1997). "Development, differentiation, and maturation of Kupffer cells." Microsc Res Tech 39(4): 350-64.
- Naro, F., V. Donchenko, S. Minotti, L. Zolla, M. Molinaro and S. Adamo (1997). "Role of phospholipase C and D signalling pathways in vasopressin-dependent myogenic differentiation." J Cell Physiol 171(1): 34-42.
- Nathanson, M. H., A. D. Burgstahler, A. Mennone, M. B. Fallon, C. B. Gonzalez and J. C. Saez (1995). "Ca²⁺ waves are organized among hepatocytes in the intact organ." Am J Physiol 269(1 Pt 1): G167-71.
- Nathanson, M. H., M. S. Moyer, A. D. Burgstahler, A. M. O'Carroll, M. J. Brownstein and S. J. Lolait (1992). "Mechanisms of subcellular cytosolic Ca²⁺ signaling evoked by stimulation of the vasopressin V1a receptor." J Biol Chem 267(32): 23282-9.
- Nervi, C., L. Benedetti, A. Minasi, M. Molinaro and S. Adamo (1995). "Arginine-vasopressin induces differentiation of skeletal myogenic cells and up-regulation of myogenin and Myf-5." Cell Growth Differ 6(1): 81-9.
- North, W. G. (1991). "Neuropeptide production by small cell carcinoma: vasopressin and oxytocin as plasma markers of disease." J Clin Endocrin Metab 73(6): 1316-1320.
- Patton, E. E., A. R. Willems, D. Sa, L. Kuras, D. Thomas, K. L. Craig and M. Tyers (1998). "Cdc53 is a scaffold protein for multiple Cdc34/Skp1/F-box protein complexes that regulate cell division and methionine biosynthesis in yeast." Genes Dev 12(5): 692-705.
- Rasio, D., M. Negrini and C. M. Croce (1995). "Genomic organization of the ATM locus involved in ataxia-telangiectasia." Cancer Research 55(24): 6053-7.
- Ruff, M. R. and C. B. Pert (1984). "Small cell carcinoma of the lung: macrophage-specific antigens suggest hemopoietic stem cell origin." Science 225(4666): 1034-6.
- Ruff, M. R. and C. B. Pert (1987). "Human monocyte chemotaxis to neuropeptides." Adv Biochem Psychopharmacol 43: 247-60.
- Sato, Y., K. Mukai, S. Watanabe, M. Goto and Y. Shimosato (1986). "The AMeX Method." A. J. Pathol. 125: 431-435.
- Spolarics, Z. (1998). "Endotoxemia, pentose cycle, and the oxidant/antioxidant balance in the hepatic sinusoid." J Leukoc Biol 63(5): 534-41.

- Thibonnier, M., C. Auzan, Z. Madhun, P. Wilkins, L. Berti-Mattera and E. Clauser (1994). "Molecular cloning, sequencing, and functional expression of a cDNA encoding the human V1a vasopressin receptor." J Biol Chem 269(5): 3304-10.
- Thurman, R. G., B. U. Bradford, et al. (1997). "Role of Kupffer cells, endotoxin and free radicals in hepatotoxicity due to prolonged alcohol consumption: studies in female and male rats." J Nutr 127(5 Suppl): 903S-906S.
- Tomlinson, I. P., J. E. Strickland, A. S. Lee, L. Bromley, M. F. Evans, J. Morton and J. O. McGee (1995). "Loss of heterozygosity on chromosome 11 q in breast cancer." Journal of Clinical Pathology 48(5): 424-8.
- Torres, B. A. and H. M. Johnson (1988). "Arginine vasopressin (AVP) replacement of helper cell requirement in IFN-gamma production. Evidence for a novel AVP receptor on mouse lymphocytes." J Immunol 140(7): 2179-83.
- Towbin, H., T. Staehelin and J. Gordon (1979). "Electrophoretic transfer of proteins from polyacrylamide gels to nitrocellulose sheets: procedure and some applications." Proc. Natl. Acad. Sci. USA 76: 4350-4354.
- Verma, R., R. M. Feldman and R. J. Deshaies (1997). "SIC1 is ubiquitinated in vitro by a pathway that requires CDC4, CDC34, and cyclin/CDK activities." Mol Biol Cell 8(8): 1427-37.
- Wiles, P. G., P. J. Grant and J. A. Davies (1986). "The differential effect of arginine vasopressin on skin blood flow in man." Clin Sci 71(6): 633-8.
- Willems, A. R., S. Lanker, E. E. Patton, K. L. Craig, T. F. Nason, N. Mathias, R. Kobayashi, C. Wittenberg and M. Tyers (1996). "Cdc53 targets phosphorylated G1 cyclins for degradation by the ubiquitin proteolytic pathway." Cell 86(3): 453-63.

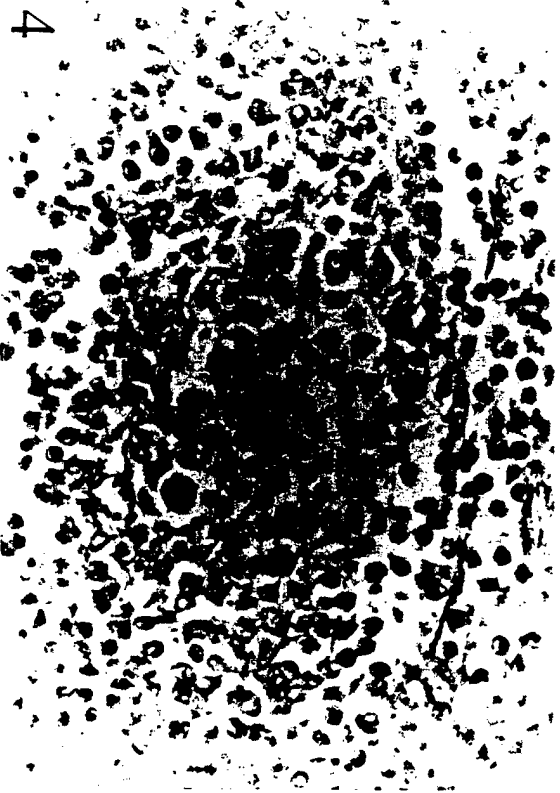



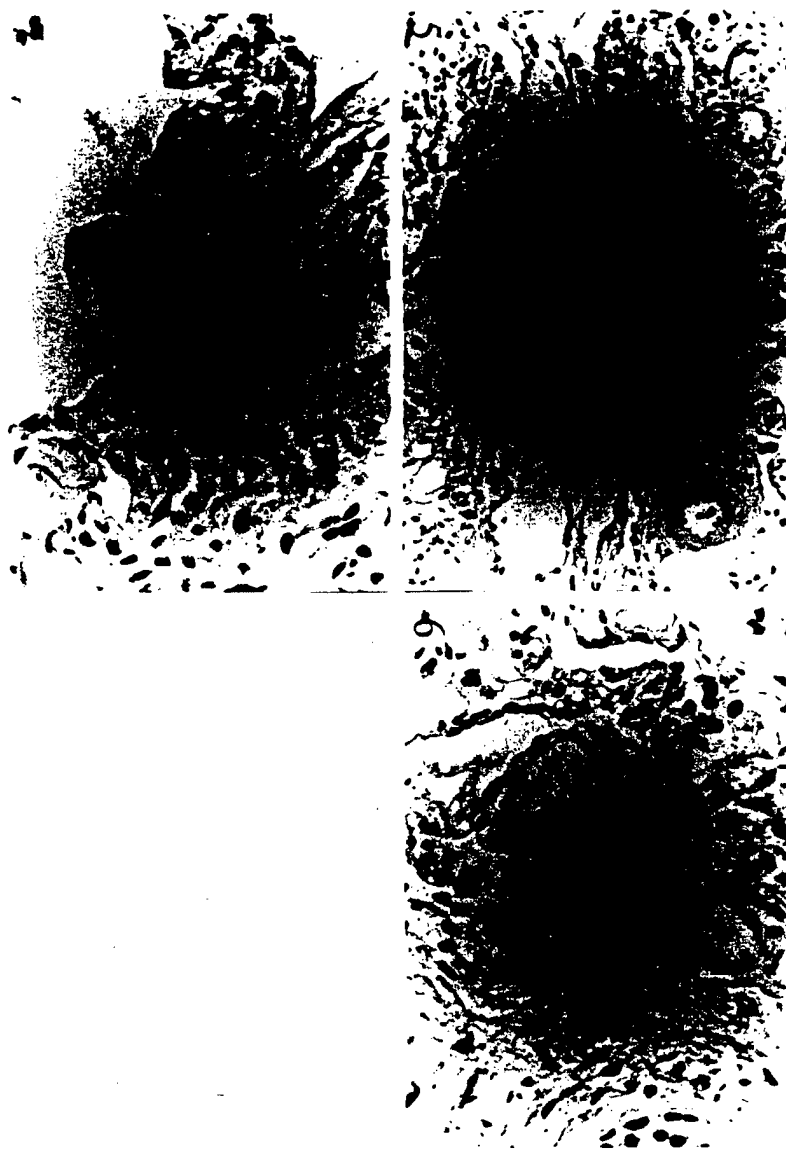

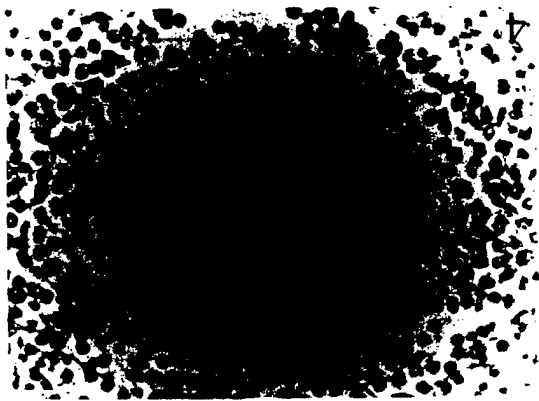

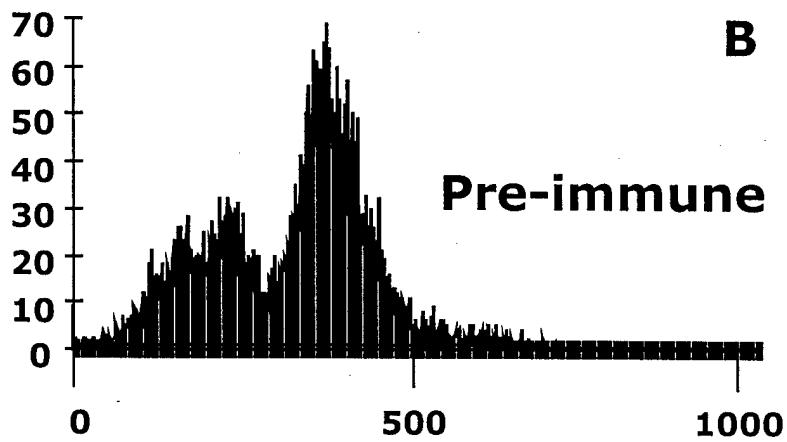
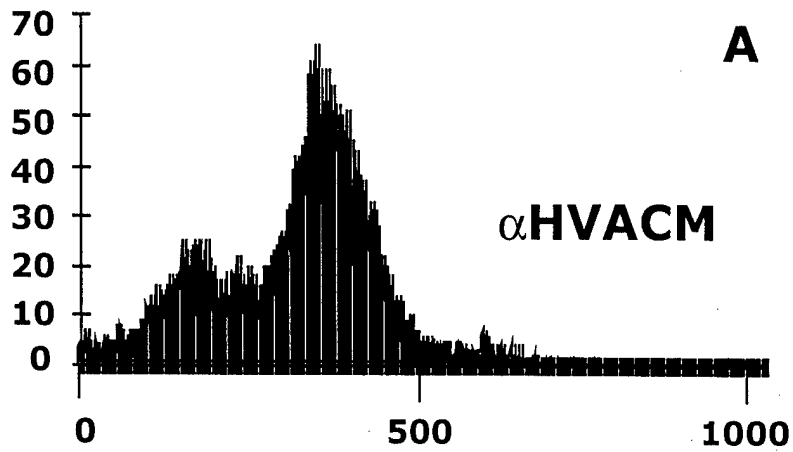

Figure 8

PI Cul-5



← **95 kD**

← **50 kD**

Figure 9

*Retormated
and Submitted to Biochim Biophys Acta
1999*

TITLE

Small cell lung cancer expresses a functional form of VACM-1, a putative vasopressin receptor and cullin family member.*

Kenneth A. Longo[‡], Michael J. Fay[§], Jinlin Du, and William G. North. From the Department of Physiology, Dartmouth Medical School, Lebanon, NH 03766 and the [§]Department of Pharmacology, MidWestern University, Downers Grove, IL 60515

SUMMARY

Vasopressin (AVP)¹ may be involved in human lung cancer pathophysiology, as an autocrine/paracrine hormone. AVP can act through four classes of receptors: V₂, V_{1a}, V_{1b}, and the vasopressin-activated calcium mobilizing (VACM-1) receptor, a structurally unique member of this group. (Recently, a highly homologous cDNA, termed Hs-VACM-1, was cloned from human placental mRNA.) A human orthologue of rabbit VACM-1 is expressed in the small cell lung cancer cell line NCI-H146. AVP induced an increase in intracellular free calcium in this cell line, but no increase in total inositol phosphates. NCI-H146 expressed three distinct mRNA bands of 3.5, 5 and 6.5 kilobases by Northern blot. RT-PCR products of the predicted sizes of 674 bp and 193 bp were amplified from NCI H-146, normal human lung and kidney RNA, using primers designed from the rabbit VACM-1 and a human expressed sequenced tag with homology to VACM-1. Overlapping 5'RACE and 3'RACE products were cloned from NCI-H146 RNA, and sequenced. The clone, named HVACM, encodes an open reading frame (ORF) of 780 amino acids and shares a high degree of amino acid identity to the rabbit VACM-1 (97%) and the Hs-VACM-1 (97%) as well as the cullins, a family of proteins involved in ubiquitin-mediated cell cycle regulation.

INTRODUCTION

Several human arginine vasopressin (AVP) receptors of the seven-transmembrane domain, G-protein linked, class have been cloned and characterized (1, 2, 3). The V_2 receptor is coupled to the enzyme adenylate cyclase. The expression of this receptor has been demonstrated in the kidney, and its activation by AVP leads to the insertion of aquaporins in the luminal membranes of principal cells, and increased water reabsorption (4, 5, 6, 7, 8, 9). Two classes of V_1 receptor have been defined. The V_{1a} receptor is expressed in arterial smooth muscle, and activates phospholipase C, which in turn leads to the generation of inositol triphosphate (IP_3) and diacylglycerol (DAG), and elevates intracellular calcium and activates protein kinase C, respectively (10, 11, 12, 13, 14, 15, 16). Activation of this receptor is responsible for contraction of arterial smooth muscle, mediating pressor activity and maintenance of blood pressure. The V_{1b} receptor also known as the V_3 receptor (17), is expressed in the adenohypophysis (18, 19). The V_{1b} receptor can also stimulate phosphoinositide hydrolysis and increases in intracellular calcium; several members of the phospholipase family have been hypothesized as partners for this receptor (18, 19, 20).

Recently, a potential new member of the AVP receptor family was expression-cloned from rabbit kidney medulla. This putative vasopressin activated calcium mobilizing receptor, VACM-1 (GenBank accession number S78157), encodes a protein larger than the serpentine receptors (780 amino acids), and does not fit the seven-transmembrane domain model (21). VACM-1 has been postulated to be a single-transmembrane domain protein due to the presence of a hydrophobic segment of 20 amino acids, though its topology or orientation with the membrane have not been definitively determined. VACM-1 overlaps mechanistically with the V_1 receptors: the stimulation of these receptors induces increases in intracellular calcium (21, 22). In contrast to the V_1 receptors, VACM-1 is not G-protein linked, and can generate Ca^{2+} increases without the production of IP_3 . The mechanism for the Ca^{2+} elevation induced by this receptor is unknown.

A human homologue of this receptor, Hs-VACM-1 (GenBank accession number

X81882), was recently cloned and mapped to chromosome 11 (q22-23) (23). This discovery was made through a study of the disorder Ataxia Telangiectasia, which maps to the same locus (24). The receptor mRNA is ubiquitously expressed (23), but the physiology or function of this protein is unknown. The homology of this receptor with the cullins, a family of proteins implicated in the ubiquitin-mediated degradation of cyclins (or cyclin/CDK inhibitors) suggests a role for the VACM proteins in similar degradative processes (25, 26, 27, 28).

Work in our laboratory has demonstrated the presence of a VACM-1-like mRNA in the small cell lung cancer cell line NCI-H146, and a preliminary report on this work has been presented (29). We have performed Northern blot analysis for the mRNA, and have isolated a cDNA clone for this putative receptor, that we have named the human vasopressin-activated calcium mobilizing (HVACM) receptor. HVACM has considerable homology to both the genomic human (HS-VACM-1) and the rabbit (VACM-1) receptors, and contains an ORF encoding a putative protein of 780 amino acids. HVACM could be a functional protein in NCI-H146, since this cell line does not appear to express mRNAs for any of the other known AVP receptors (V_2 , V_{1a} , and V_{1b}), but responds to AVP stimulation with an increase in intracellular calcium originating from an intracellular store that is distinct from the ryanodine-sensitive smooth endoplasmic reticulum calcium reservoirs.

EXPERIMENTAL PROCEDURES:

Cell culture - NCI-H146 cells were obtained from the American Type Culture Collection (Rockville, MD), and maintained in RPMI 1640 supplemented with 10% fetal bovine serum (Hyclone Laboratories, Logan UT), without antibiotics.

RT-PCR analysis of HVACM mRNA expression - Total RNA from NCI-H146 was analyzed for the presence of VACM-1-like mRNA using the reverse transcription polymerase chain reaction (RT-PCR). Briefly, 1 μ g of total RNA was reverse transcribed using the Superscript II enzyme (Life Technologies, Gaithersburg, MD), and subsequently subjected to 35 cycles of PCR using the *Taq* polymerase enzyme (Perkin Elmer, Branchburg, NJ) (28).

Synthetic primers 1432F (5' GAATGGGTAAGAGAAGTTGGTATG 3'), 2082R (5' TCTTCTCTCATCCTTTCTGTAGTG 3'), 325F (5' CATAACCACTTCTCTTAGCCACTC 3'), and 156R (5' CACCATTAAGCAAACTACCTCTG 3') were designed using the program Oligo™ for the Macintosh, and purchased from Life Technologies (Gaithersburg, MD). The primers 1432F/2082R and 325F/156R amplify a 674 base pair (bp) fragment and a 193 bp fragment, respectively, within the putative ORF for HVACM-1. Conditions for PCR involved an initial denaturation step (96 °C, 2.5 min). This was followed by 35 cycles of the following sequence: 96 °C for 45 s; 60 °C for 45 s; and 72 °C for 1.5 min, and a final extension time of 10 min. RT-PCR products were separated by 1% agarose gel electrophoresis, and visualized with ethidium bromide staining over a UV transilluminator.

Northern blotting of HVACM mRNA - Total RNA was extracted from NCI-H146 using 4 M guanidinium thiocyanate and subsequent cesium chloride gradient centrifugation, and electrophoresed through a 1.2% agarose gel containing 1.1% formaldehyde. The RNA was transferred to nitrocellulose overnight using 20xSSC as the mobile phase, followed by baking of the membrane (80 °C, 2 h). The membrane was then incubated in 50% formamide, 5 x SSPE, 5 x Denhardt's reagent, 0.1 mg/ml salmon sperm DNA, and 0.1% SDS, at 42 °C for 2 h. This was followed by incubation in the presence of a radiolabeled probe for 16 h at 42 °C. The probe corresponds to the 674 bp fragment generated by RT-PCR from NCI-H146 total RNA using the primer pair 1432/2082, and was ³²P-labeled with a DecaPrime DNA labeling kit (Ambion, Austin, TX). Any non-specifically bound probe was removed from the membrane by washing for 20 m at RT with 10 ml 1 x SSC, 0.1% SDS. Three additional washes were performed at 68 °C with 0.2 x SSC, 0.1% SDS. Interaction with the probe was resolved by autoradiography (30).

Isolation of HVACM nucleotide clones - Both 5'- and 3'- rapid amplification of cDNA ends (RACE) (25, 31) were employed to clone the open reading frame of this gene. An initial reverse transcription was performed (see above) using the primer 138R (5' TTGTTTTTGTAAGGTAAGGCAGAG 3'). 5'RACE was performed using the primers 5'ATGF (5' TCCAAGTTAAAGAACATGGCG 3') and 2082R. 3'RACE was performed using the

bovine serum albumin for 24 h at 37 °C. The cells were assayed for total inositol phosphate production in a physiological salt solution containing lithium chloride (PSS) pH 7.35, with the following composition: NaCl (105 mM), LiCl (30 mM), NaHCO₃ (4.2 mM), KCl (5.9 mM), CaCl₂ (1.8 mM), MgCl₂ (1.4 mM), NaH₂PO₄ (1.2 mM), glucose (11 mM), HEPES (10 mM). Following three washes with 5 ml PSS, the cells were incubated in the same solution for 10 m at 37 °C. They were stimulated with 1000 nM AVP for a 30 min time period at 37 °C. Aliquots were periodically removed and total inositol phosphates extracted. For this extraction, the cell suspension was added to one tenth (1/10) volume (v/v) of 5 N perchloric acid, 1 mM EDTA, and 5 mM DEPTA, and placed on ice for 30 min. Subsequently, one volume (v/v) of 1.5% K₂CO₃ was added to the acid extracts to precipitate cellular debris, and the extracts were placed on ice for 2 h. After centrifugation, neutralized extracts of 1 ml were loaded onto AG1-X8 resin (formate form) (BioRad, Hercules, CA) columns equilibrated with 20 mM NH₄OH. The columns were washed sequentially with 4 ml 40 mM NH₄OH, 4 ml of 40 mM ammonium formate., and finally with 4 ml 2 M ammonium formate/0.1 M formic acid. For detection, 1 ml of the final wash was added to 10 ml of Hydrofluor scintillation fluid, and values of counts per minute (cpm) from [³H]phosphoinositides were obtained. Data were obtained from five independent experiments and expressed as an average ratio of the control values, and their standard error.

RESULTS:

RT-PCR analysis of HVACM RNA - Bands of the predicted sizes 674 bp and 193 bp, were generated using the VACM-1 selected primers 1432F/2082R and 325F/156R, indicating that an mRNA with considerable homology to the rabbit VACM-1 was being expressed in NCI-H146 (Figure 1). Bands of similar size were also amplified from normal human kidney and normal human lung RNA (data not shown).

Northern Analysis of HVACM RNA - Messenger RNAs of three distinct sizes were observed upon Northern analysis of total NCI-H146 RNA (Figure 2). These sizes were 6.5, 5.0,

primers 1432F and 138R. The *Pfu* polymerase (Stratagene, La Jolla, CA) was utilized for higher fidelity PCR. After an initial denaturation step (96 °C, 2.5 m), 35 cycles of the following sequence were conducted: 96 °C for 45 s; 55 °C for 45 s; and 72 °C for 8 min. These cycles were followed with a final extension time of 20 min. PCR products were visualized with gel electrophoresis and ethidium bromide staining/UV illumination, and cloned into the pZERO- (Blunt) vector (Invitrogen, Portland, OR) for further analysis.

DNA sequencing of HVACM RACE clones - All sequencing was performed using the ABI/Prism automated sequencing system (Perkin Elmer, Branchburg, NJ). The software packages Align and MegAlign (DNASTar, Inc.) and Gene Inspector (Textco, Inc.) were employed for sequence analysis. Protein motifs were identified using a program available on the Internet, MotifFinder (Institute for Chemical Research, Kyoto University). Hydrophobicity analysis of protein was performed using the algorithm of Kyte and Doolittle (32).

Calcium analysis - Cells (2.0×10^6 cells/ml) were incubated in serum-free media in the presence of the calcium indicator Fura-2AM (final concentration 5 mM) (Calbiochem, San Diego, CA), at 37 °C for 1 h. The cells were washed and resuspended in Dulbecco's PBS with 2.5 mM Ca^{2+} or without Ca^{2+} at a final concentration of 10^6 cells/ml. The cell suspension was pre-warmed (to 37 °C) and analyzed in a quartz cuvette. $[\text{Arg}^8]\text{AVP}$, the V_{1a} agonist $[\text{Phe}^2, \text{Ile}^3, \text{Orn}^8]\text{AVP}$, or the V_{1b} agonist $[\text{deamino}^1, \text{D-3-(pyridyl)Ala}^2, \text{Arg}^8]\text{AVP}$ were added directly to the cuvette. All peptides were purchased from Bachem (Torrance, CA). When indicated, cells were pre-incubated with the SER Ca^{2+} blocker TMB-8 (final concentration 10 μM) for 10 min at 37 °C. Using a Perkin Elmer LS50B luminescence spectrometer, the cells were subjected to dual excitation wavelengths of 340 and 380 nm. The ratio of emission intensity at 485 nm with each of these excitation wavelengths (*I/I*) was determined. (The resulting *I/I* value is an arbitrary indicator of increases in $[\text{Ca}^{2+}]_i$.)

Inositol Phosphate analysis of NCI-H146 - Total inositol phosphates were quantified using a modification of the method of Berridge et al. (33). NCI-H146 cells were labeled with $[\text{3H}]\text{myo-inositol}$ (DuPont-NEN, Boston, MA) in myo-inositol-free RPMI 1640, with 0.1%

and 3.5 kilobases (kb). This result was in agreement with other published results (23).

Isolation of an ORF clone of HVACM from NCI-H146 - Overlapping 5'- and 3'-RACE products of ~2.1 kb and 1.1 kb were amplified, cloned in the vector pZERO-Blunt (Invitrogen), and sequenced. This clone contains a ORF of 2340 nucleotides, encoding a putative protein of 780 amino acids (Figure 3). The HVACM protein shares 97% identity with both Hs-VACM-1 and VACM-1 through comparisons using BLAST. Neither Gene Inspector™ nor MOTIF predicted an amino acid sequence with sufficient hydrophobicity to classify it as a transmembrane protein (Figure 4). No signal sequence was detected in this protein. However, several other unconfirmed motifs were predicted. The ORF of HVACM contains two protein kinase A (PKA) phosphorylation domains at Thr427 and Ser731. Additionally, there are 15 casein kinase II phosphorylation sites and 15 PKC phosphorylation sites. A single tyrosine kinase phosphorylation domain resides at Tyr207. There are two myristoylation sites contained by residues 180..185 and by 664..669. There are three N-glycosylation sites represented by residues Asn145, Asn289, and Asn566. Finally, a cullin homology domain was identified in the C-terminal 27 amino acids of HVACM. Additional homology between HVACM and the cullins outside of this region was also detected.

AVP does not stimulate the production of phosphoinositides in NCI-H146 - An increase in total phosphoinositides (IP) was not observed following treatment with 1000 nM AVP (Figure 5). A slight decrease in total IP levels was actually apparent in the first 10 minutes following AVP treatment indicating that an IP₃-dependent mechanism was not responsible for the AVP-induced increases in intracellular calcium.

AVP modulates intracellular Ca²⁺ in NCI-H146 - An increase in [Ca²⁺]_i was observed in NCI-H146 after treatment with 1000 nM AVP (Figure 6a). Neither a V1a agonist (3 μM) or a V1b agonist (36 μM) were able to elicit [Ca²⁺]_i release when used at concentrations with similar activity to [Arg⁸]AVP (Figures 6b and 6c, respectively) (34, 35, 36). Depletion of Ca²⁺ from the medium did not block the action of AVP (Figure 6d), nor did pre-treatment of the cells with the SER-specific Ca²⁺ blocker TMB-8 (Figure 6e).

DISCUSSION:

The cDNA that we have named HVACM shares considerable amino acid identity with both Hs-VACM-1 and the rabbit VACM-1. In all likelihood, all three forms probably encode proteins sharing identical mechanistic and physiologic properties. The considerable sequence similarity between the human and rabbit proteins suggests a highly conserved evolutionary role for this protein.

The interaction of AVP with VACM-1 is able to induce increases in intracellular calcium. In this study, the inability of TMB-8 to block intracellular release of calcium suggests that HVACM (and therefore VACM-1) is stimulating an as yet undefined intracellular pool of calcium ions.

In addition to the basolateral localization of VACM-1 in rabbit kidney collecting duct, there was also a prominent cytoplasmic localization, and a minor nuclear localization, of this protein as evidenced from interactions with an antibody to its C-terminal domain in fluorescence microscopy (21). While this has yet to be confirmed for HVACM in the cell line NCI-H146, it raises the distinct possibility that VACM-1 (and HVACM) are not transmembrane proteins, but rather cytoplasmic proteins that associate with the plasma membrane weakly and/or dynamically. The position of HVACM in different cellular compartments or plasma membranes may be mediated through its association(s) with other proteins. AVP, by virtue of its interaction with HVACM, may control the localization and/or function of HVACM. The myristoylation and glycosylation domains on the proteins may allow VACM-1 and HVACM to associate with the plasma membrane. Clearly, more study is required to understand the cellular localization of VACM proteins.

Since mRNAs for VACM proteins are co-expressed in many of the same tissues as the V1a receptor, the important question of functional overlap is raised. Are these receptors functionally synergistic and involved in the same physiologic processes? Are they antagonistic and involved in each other's regulation? Do they have distinct physiologic roles and exist outside

of the other's regulation?

Certainly, the (unconfirmed) presence of copious PKC domains in HVACM insinuates that some inter-regulation between HVACM and V1a may occur physiologically. Future experiments should determine whether or not AVP can stimulate the phosphorylation of HVACM in cell systems where V1a and HVACM are co-expressed. Additionally, the presence of two PKA domains in HVACM suggests some form of inter-regulation with the V2 receptor may exist, and should be investigated.

Perhaps the most intriguing aspect of HVACM is its considerable homology to the cullins, a family of proteins implicated in the ubiquitin-mediated degradation of G1- and M-phase cyclins, or their inhibitors (37, 38). The cullins appear to serve a highly conserved regulatory role in the cell cycle of eukaryotes from yeast (37) to humans (36). By virtue of this domain, HVACM may be involved in the ubiquitin-mediated degradation of cellular proteins.

Individual cullin proteins are a part of defined multimeric protein complexes that serve as functional ubiquitin ligases (25, 26, 27, 28). The interaction of cullins with these complexes is mediated through the C-terminal amino acids that form the cullin homology domain (25). HVACM may also associate with other proteins as a necessary prerequisite for its functions in this enzymatic capacity. Whether cullins provide substrate specificity or enzymatic activity to these ubiquitin ligase complexes, or are merely scaffold proteins for these complexes, is not clearly understood (26). The fact that several cullin subtypes exist in humans suggests that the cullin proteins may serve tissue- or hormone-specific regulatory roles (39).

The ability of VACM-1 to specifically bind to AVP suggests that this hormone may affect the function of VACM-1/HVACM. The potential regulatory role of AVP in the physiology and function of HVACM warrants further investigation.

ACKNOWLEDGMENTS:

The authors would like to thank the members of the Molecular Biology Core Facility at Dartmouth for their expertise in all of the DNA sequencing performed for this work, and Susan

Gagnon for her technical assistance.

REFERENCES:

1. B. I. J. G. G. Mouillac, (1991)*Zeitschrift fur Kardiologie* 7, 79-81.
2. M. C. Carmichael, R. Kumar, (1994)*Semin Nephrol* 14, 341-8.
3. H. H. Zingg, (1996)*Baillieres Clinical Endocrinology & Metabolism* 10, 75-96.
4. R. Schulein, U. Liebenhoff, H. Muller, M. Birnbaumer, W. Rosenthal, (1996)*Biochem J* 313, 611-6.
5. V. Gorbulev, H. Buchner, A. Akhundova, F. Fahrenholz, (1993)*Eur J Biochem* 215, 1-7.
6. C. Barberis, A. Seibold, M. Ishido, W. Rosenthal, M. Birnbaumer, (1993)*Regul Pept* 45, 61-6.
7. S. J. Lolait, et al., (1992)*Nature* 357, 336-9.
8. A. Morel, S. J. Lolait, M. J. Brownstein, (1993)*Regul Pept* 45, 53-9.
9. M. Birnbaumer, et al., (1992)*Nature* 357, 333-5.
10. A. M. Hutchins, P. A. Phillips, D. J. Venter, L. M. Burrell, C. I. Johnston, (1995)*Biochim Biophys Acta* 1263, 266-70.
11. E. M. Briley, S. J. Lolait, J. Axelrod, C. C. Felder, (1994)*Neuropeptides* 27, 63-74.
12. A. Hirasawa, K. Shibata, K. Kotosai, G. Tsujimoto, (1994)*Biochem Biophys Res Commun* 203, 72-9.
13. M. Thibonnier, et al., (1994)*J Biol Chem* 269, 3304-10.
14. A. Morel, A. M. O'Carroll, M. J. Brownstein, S. J. Lolait, (1992)*Nature* 356, 523-6.
15. L. A. R. A. S. W. J. Klein, (1969)*Surgical Forum* 20, 231-3.
16. C. Serradeil-Le Gal, et al., (1995)*Am J Physiol* 268, H404-10.
17. Y. de Keyser, et al., (1994)*FEBS Lett* 356, 215-20.
18. M. Saito, T. Sugimoto, A. Tahara, H. Kawashima, (1995)*Biochem Biophys Res Commun* 212, 751-7.
19. T. Sugimoto, et al., (1994)*J Biol Chem* 269, 27088-92.
20. S. J. Lolait, et al., (1995)*Proc Natl Acad Sci U S A* 92, 6783-7.
21. M. A. Burnatowska-Hledin, et al., (1995)*Am J Physiol* 268, F1198-210.
22. M. H. Nathanson, et al., (1992)*J Biol Chem* 267, 23282-9.
23. P. J. Byrd, et al., (1997)*Genome Research* 7, 71-5.
24. H. J. Ambrose, et al., (1994)*Genomics* 21, 612-9.
25. N. Mathias, C. N. Steussy, M. G. Goebel, (1998)*J Biol Chem* 273, 4040-5.
26. E. E. Patton, et al., (1998)*Genes Dev* 12, 692-705.
27. H. Yamada, K. Kumada, M. Yanagida, (1997)*J Cell Sci* 110, 1793-804.
28. L. S. Drury, G. Perkins, J. F. Diffley, (1997)*Embo J* 16, 5966-76.
29. K. A. Longo, W. G. North, J. Du, M. J. Fay, (1997)*World Congress of Neurohypophyseal Hormones*.
30. J. Sambrook, E. F. Fritsch, T. Maniatis, 1989, *Molecular Cloning: A Laboratory Manual* (Cold Spring Harbor Laboratory Press, New York, ed. Second).
31. Y. Liu, N. Mathias, C. N. Steussy, M. G. Goebel, (1995)*Mol Cell Biol* 15, 5635-44.
32. J. Kyte, R. F. Doolittle, (1982)*J Mol Biol* 157, 105-32.
33. M. J. Berridge, R. Dawson, C. Downes, J. Heslop, R. Irvine, (1983)*Biochem J* 212, 473-482.
34. M. Manning, B. Lammek, K. Bankowski, J. Seto, W. H. Sawyer, (1985)*Journal of Medicinal Chemistry* 28, 1485-91.
35. M. Manning, W. H. Sawyer, (1989)*Journal of Laboratory & Clinical Medicine* 114, 617-32.
36. J. Schwartz, I. Derdowska, M. Sobocinska, G. Kupryszewski, (1991)*Endocrinology* 129, 1107-9.

37. R. M. Feldman, C. C. Correll, K. B. Kaplan, R. J. Deshaies, (1997)*Cell* 91, 221-30.
38. H. Yu, et al., (1998)*Science* 279, 1219-22.
39. E. T. Kipreos, L. E. Lander, J. P. Wing, W. W. He, E. M. Hedgecock, (1996)*Cell* 85, 829-39.

FOOTNOTES

*This work was supported in part by grants from the National Institutes of Health (CA-19613) and the Department of Defense (DAMD 17-94-J-4288). Michael Fay was supported as a postdoctoral fellow by NIH training grant T32DK07508 and a DOD fellowship DAMD 17-94-J-4131. Kenneth Longo was supported by generous grants from the Dolores Zhorhab Liebmann Foundation and the Stephen J. Ryan Foundation.

The nucleotide sequence of HVACM cloned from NCI-H146 has been deposited in the GenBank database under GenBank Accession Number AF016071.

‡To whom correspondence should be addressed: Department of Physiology, Rm. 752E, 1 Medical Center Drive, Lebanon, NH 03766. Tel.: 603-650-7736; Fax.: 603-650-6130.

ABBREVIATIONS

¹The abbreviations used are: AVP, [Arg8]vasopressin; PBS, phosphate buffered saline; IP, phosphoinositides; IP₃, inositol triphosphate; [Ca²⁺]_i, intracellular calcium; RT-PCR, reverse transcription polymerase chain reaction; PKA, protein kinase A; PKC, protein kinase C; ORF, open reading frame; TMB-8, 8-(Diethylamino)-octyl-3,4,5- trimethoxybenzoate, HCl; SER, smooth endoplasmic reticulum.

FIGURE LEGENDS

FIG. 1. RT-PCR for VACM-1 from NCI-H146 total RNA. Primers use for PCR: lane 1; 1432/2082, lane 2; 156/325.

FIG. 2. Northern blot analysis of VACM-1 messenger RNA from NCI-H146 total RNA (20 ug).

FIG. 3. Predicted open reading frame nucleotide sequence of HVACM cloned from NCI-H146. The putative amino acid sequence is also shown.

FIG. 4. Hydrophobicity profile of HVACM. Protein hydrophobicity was calculated using the algorithm of Kyte and Doolittle (32). The vertical axis represents hydrophobicity for HVACM amino acids, which are represented by the horizontal axis.

FIG. 5. Total inositol phosphate analysis of NCI-H146 following stimulation with 1000nM AVP over 30 minutes. Data are presented as the ratio of control (unstimulated) values of [3H]inositol counts per minute, +/- S.E. (n=5).

FIG. 6. Intracellular calcium analysis of FURA-2AM-loaded NCI-H146 cells. Stimulation with (a) 1000nM AVP, (b) V1a agonist, (c) V1b agonist, (d) 1000nM AVP minus extracellular calcium, (e) 1000nM AVP plus pre-incubation with 100uM TMB-8.

1

2

674 bp →

193 bp →



6.5 kb →

5.0 kb →

3.5 kb →

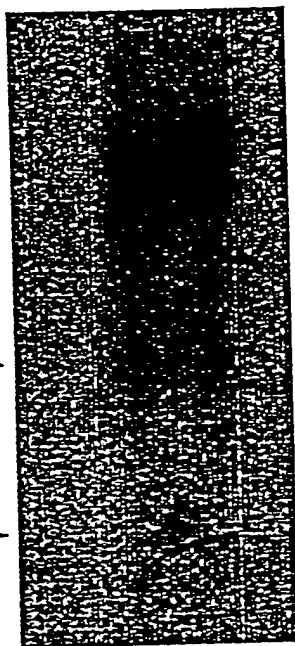

1 ATGGCGACGTCFAATCTGTTAAAGCAATAAAGGTTCTCTTCAGTTTGAAGACAAAATGGGATTTTATCGCCCGATTGGTTTGAAGCTTTTACGCCACGAAT
101 CTGTTACTAAACAGCAGTGTGTTTTCGATCTTTTTTCGGATGTCATGTCAGTCTGCTTTTGGGATGATAAAGGCCACCAAAAATTTCATCAGGCTTTAAAAGA
34> S V T K Q Q W F D L F S D V H A V C L W D D K G P P K I H Q A L K E

201 AGATATTTCTTGAGTTTATTANGCAAGCAGCAGGACAGTACTGAGCCATCAAGATGATAAGGCTTTGCTAAAAGCATAATTGTTGAATGGCCAAAGTTC
67> D I L E F I K Q K Q A R V L S H Q D D T A L L K A Y I V E W R K F

301 TTACACAATGTGATATTTTACCAAAACCTTTTTGCACTAGAGATTACTTTAATGGGTAACAGGGCAGCAATAAAAAATCAATGTGGAACAGTA
102> F T Q C D I L P K P F C Q L E I T L M G K Q G S N K K S N V E D S

401 TTGTTCCGAAGCTTTATGCTTGATACATGGAATGAGTCAATCTTTTGAACATAAAAACAGACTCCAGATAGTGAATGAAACTGGTGCATGCTGAAAG
134> I V R K L M L D T W N E S I F S N I K N R L P D S A M K L V H A E R

501 ATTGGGAGAAGCTTTTTCATCAACTGGTTTATGGGATAAAAAATCCTATGTTTACCTTTGCTTAATCCTGAGGATAAACTTCCAATTTATAGGGAC
167> L G E A F D S Q L V I G I K K S Y V Y L C S N P E D K L P I Y R D

601 AATTTTGAAGGCACTACTTGGATTCCCCCGAAAGATTTTATAGAACAACAGCCCTCGTTTTTACAACAAAATGGTGTCCGAATTATTGAAAATG
202> N F E K A Y L D S P E R F Y R T Q A P S F L Q Q N G V P N Y L K Y

701 CAGATGCTCGAATTTCAGAGAAGAAAACAGGCACTACSTTTTTAGAAACAAGACGAGATGTTACTCCGTTGAGCACTCATGGAATGCTGTGTTAA
234> A D A R F P E E E K R A L R F L E T R R E C Y S V E A L M E C C V N

801 TGGCCCTGGTGACATCATTAAGAAGAACTATCTTACGTSAGTGGCCAGGCGTGTCAAAAAATGAAACTGAAAATACCTTTAATGTTTCATTGATG
267> A L V T S F K E T I L A E C P G V I K K N E T E K L P L M F S L M

901 GACAAAATTCCTAATTTGATATAAAGCCAAATGTTGAAAACCTTGGAGAACATATCATTAGTGGCTGGCCGAGATAGTGGTACAGCTGCTGAAACTATTA
302> D K V P N C I K P M L K N L E E H I I S A G L A D M V A A A E T I

1001 CTACTGACTCTGAGAAAACGTTGAGTACTTACACTATTATAGACTTTAGTAAACTCTGCAAGAAGCTTTTCAAGATGATCCAGGATTCTTAC
334> T T D S E K Y V E Q L L T L F N R F S K L V K E A F Q D D P R F L T

1101 TGGCAAGACATAGGCCATATAAGCAGTTGTTAATGATGCTACCATATTTAAACTTGAATTACCTTTGAAAACGAAAGGCGGGATTAAAAACTCAGCCT
367> A R D K A Y K A V V N D A T I F K L E L P L K Q K G V G L K T Q P

1201 GARTCAAAATGCCCTGACCTGCTGCAACTTGTGACATGCTTGAAGAAAACACCATTAGCAAAAACCTAACCTCTGAAAAGATTGAAGCAAAGC
402> E S K C P E L L A N Y C D M L L R K T P L S K K L T S E K I E A K

1301 TTAACCAAGTCTCTTGGTACTTAAATATGTACAGAACAAAGATGTTTTTATGAGTATCATAAAGCTCAITTTGACACACGCTTTATATTAGACATCTC
434> L K E V L L V L N Y V Q N K D V F M R Y H K A H L T R R L I L D I S

1401 TGGCCGATGAGAAATGAAAACCAATGCTGAGTGTGCTTAAAAGATTTGATGCGAGGGATATGTAACAAGCTTCTGAGAATGTTTCAGGACATA
467> A D S E I E K N M V E W L K X V G M P A D Y V N K L A R M F Q D I

1501 AAGTATCTGAGATTTTAAACCAAGCTTTTAAAGAAAGGCAAAATTAATAATTTGGCATTCCGCTGATTCAATATAAAAATTCTGAATGCTG
502> K V S E D L N Q A F K E M X K N N K L A L P A D S V N I K I L N A

1601 GGGCTCTGCAAGAGTCTGAGAAAGTCTTTGCTCACTTCTACTGAACTGGAGSACTGATACCGGAAGTAGAAAATTCTACAAAAAATCATAG
534> G A W S R S S E K V F V S L F T E L E D L I P E V E K F Y K K N H S

1701 TGGTAGAAATACATTTGGCATCACTCATCTGCAATGGAATTAACATTTAAGAAATGAAAGTGGTCAATATGATTTGGAGTAAACCAGTTTCAGCTC
567> G R K L H W H E L M S N G I I T F K N E V G Q Y D L E V T T F Q L

1801 GCTTATTGTTGCAITGSAACCAASACCCAGAGAGAAAATCAGCTTTGAAATCTTAAAGCTTGAACACTGAACTCCCTGATGCTGAACTTAGGAGGACTT
602> A V L F A W N Q R P R E K I S F E N L K L A T E L P D A E L R R T

1901 TATGGCTTTAGTACTTTTCCAAACIACAACGSCAACTTTTGTGTTGATGAACCTCAAGTCAACTCACCBAAGACTTTACAGAAGGTACCCCTCTCTC
634> L W S L V T F P K L K R Q V L L Y E P Q V N S P K D F T E G T L F S

2001 AGTGAACAGGAATTCAGTTTAAATAAAAATGCCAAGGTTGAAAAAGGTTAAAATCAACTGATTTGGACGTTTGGACCTCAGTACAGAAAGGATGAGA
667> V K Q E F S L I K N A K V Q K K G K I N L I G R L Q L T T E R M R

2101 GAAGAAAGGAATGAAGCAATAGTTCACTACGAAATAGTAAACCCAGGAAAGGCTATCATACAAATAATGAAAATGAGAAAGAAAATAGTAAATGCTCAGC
702> E E E N E C I V Q L R I L R T Q E A I I Q I M K M R K K I S N A Q

2201 TGCAGACTGAATTAGTAGAAAATTTTAAACAACATGTTCTTCCCAAAAAGAAAATGATAAAGAGCAAAATAGAGTGGCTAATAGAGCACAATAACATCAG
734> L Q T E L V E I L K N M F L P Q K K M I K E Q I E W L I E H K Y I R

2301 AAGAGATGAATCTGATATCAACACTTTTAAATATATGCAAAATTTTGAATATCATGGACAATATTAGAACCAAAATTTGGAGTGGCTTGGGCAGAAAG
767> R D E S D I N T F I Y M A

2401 TGTAAAATTTGCTGCTGAGACAAAAGTATTATTGCACTTTTAAATACATAAATATTATATCTCTCCCTTACCTGACAAAACAACCTGAATTCAGTGGAT
790> T G T A A A A T T T G C T G C T G A G A C A A A G T T A T T T G C A C T T T T A A A T A C A T A A A T T A T A T C T C C C T T A C C T G A C A A A A C A C C T G A A T T C A G T G G A T

2501 CCCTAGTAAAGCCCGCCAGTGTGGTGAATTAATTCCTGTCTCCGAGGCCAGCTGTTGSGGTGASTTCTCCCTCTCAAAAGCGGG

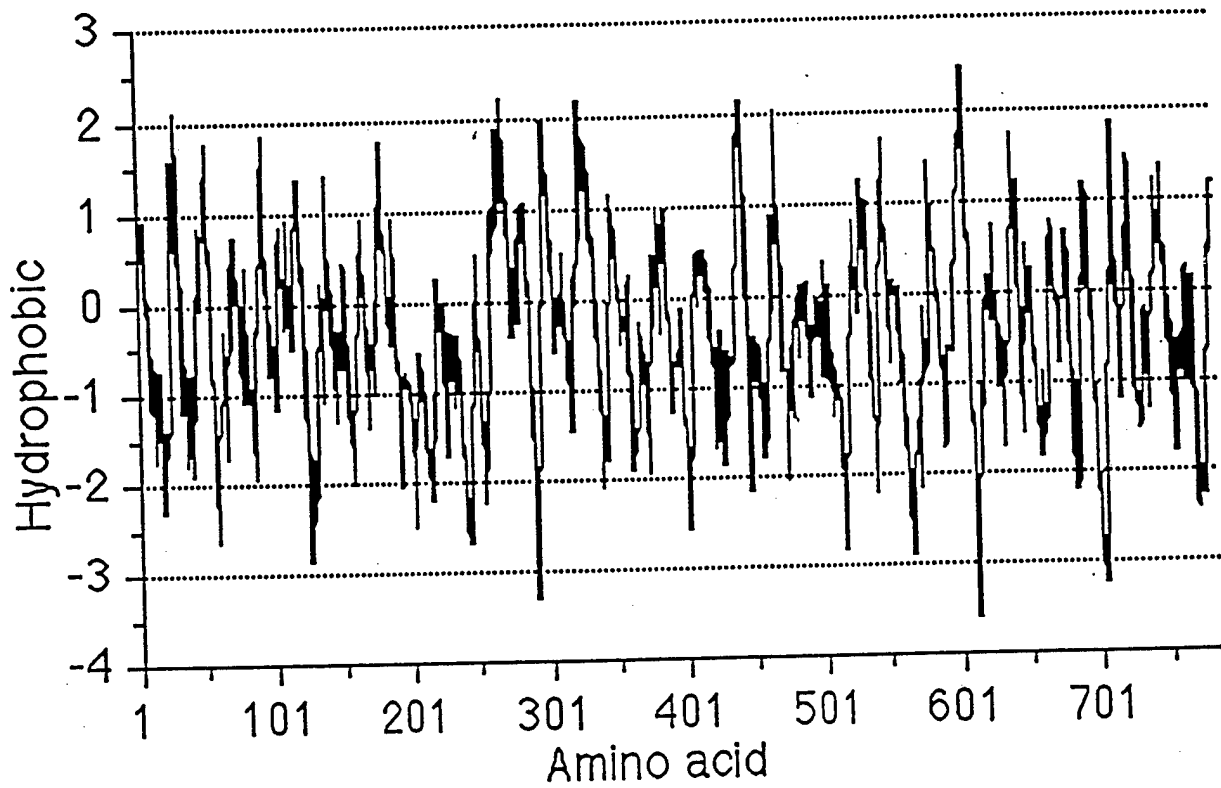

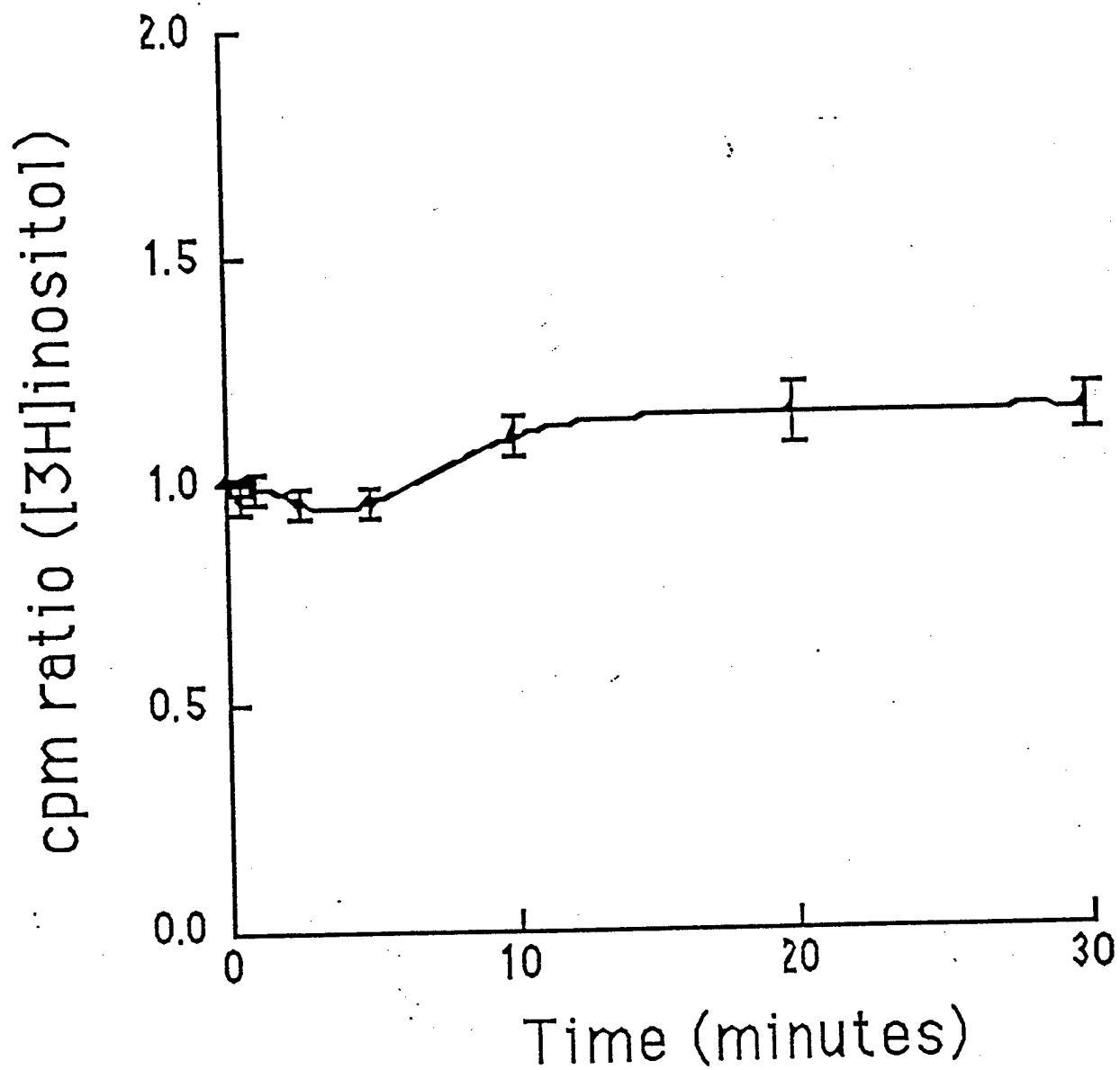

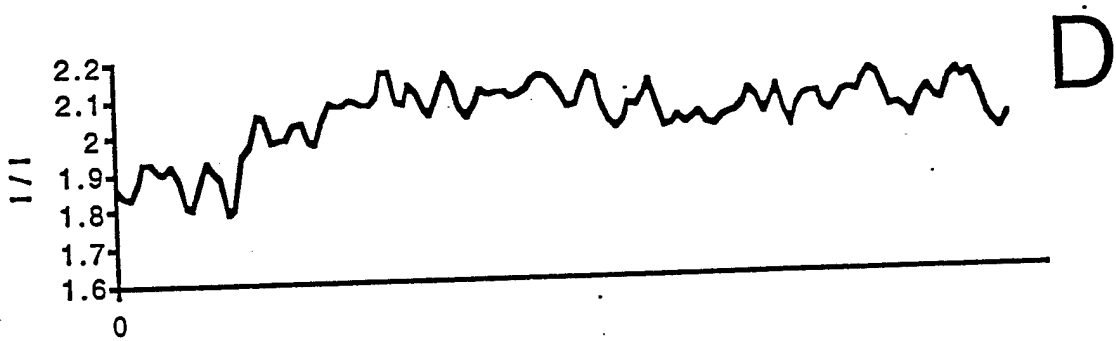
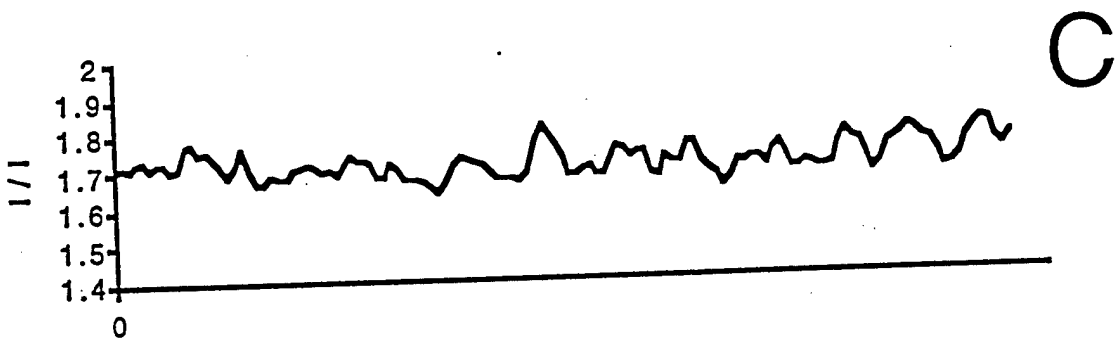
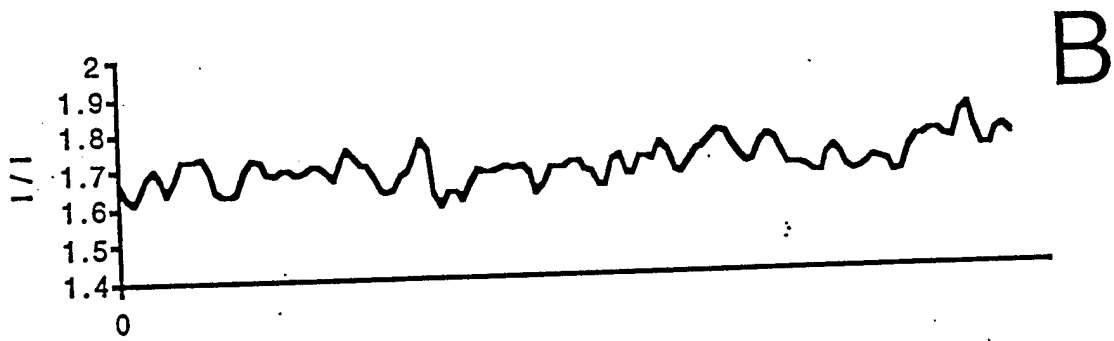
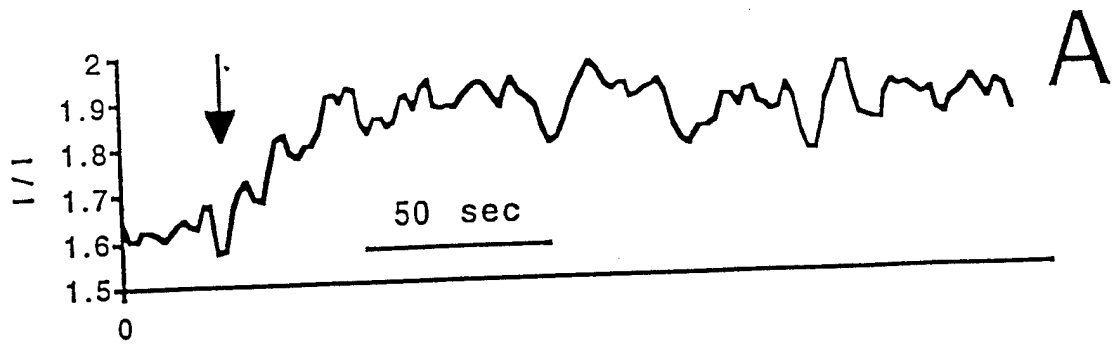

**GENE REGULATION OF VASOPRESSIN AND VASOPRESSIN RECEPTORS IN
CANCER**

WILLIAM G. NORTH

**Department of Physiology Dartmouth Medical School, Lebanon, New Hampshire,
USA**

CONTENTS	PAGE
Introduction	1
What are the clinical signs of vasopressin gene expression by tumors and what lessons do they provide	4
What types of cancer express the vasopressin gene	6
Incidence of vasopressin gene expression by small-cell lung cancer and breast cancer	7
Small-cell lung cancer	7
Breast cancer	9
Breast fibrocystic disease	10
Non-small-cell lung cancer	11
What is the nature of the vasopressin gene and gene products in cancer cells	11
Genes for processing enzymes are expressed in cancer cells	15
The nature of subcellular trafficking in cancer cells	16
All vasopressin receptor genes are expressed by cancer cells	18
What are the influences of vasopressin on cancer cell growth	20
Regulator elements that can influence the gene expression of vasopressin by cancer cells	22
Summary	25
References	27

INTRODUCTION

In 1969, Pierce introduced the **APUD** concept to explain simultaneous expression of many neuropeptides by cells of the central nervous system (CNS), gastro-entero-pancreatic system (GEPS), thyroid gland, and reproductive system, as well as by 'neuroendocrine' tumors such as small-cell lung cancer (SCLC). In his proposal, non-neuronal peptide-producing cells were believed to originate as amine-producing cells of the embryonic neural crest. Some of these cells were alleged to migrate to different sites during development and later become small pockets of peptide-producing cells imbedded in different organs. **APUD** stands for **A**mine **P**recursor **U**ptake and **D**ecarboxylation and refers to the capacity of amine-producing cells to take up tyrosine, dopa, and tryptophan and convert them into amine transmitters. The significance of this hypothesis to the field of cancer research is that it seeks to define peptide-producing tumors as coming from preexisting 'neuroendocrine' (neural crest-derived) cells of respective organs through a process of mutagenesis. Gastrinomas are therefore seen as transformed gastrin-producing 'neuroendocrine cells', and small-cell lung cancer as arising through the transformation of 'neuroendocrine' cells within the pulmonary epithelium. Perhaps of more significance to the subject under review, the APUD concept informs us that expression of peptides, and more particularly of vasopressin, is a pre-oncogenic condition that does not primarily relate to the dynamics of the tumor with regard to properties such as growth, metastasis, and survival. A discovery that peptides can promote tumor growth would then be interpreted as a secondary adaptation by the tumor to utilize pre-existing properties towards continued independence and survival. However, the transformation of pulmonary neuroendocrine cells into small-cell lung carcinoma cells has yet to be demonstrated. Additionally, many genetic abnormalities of cancer cells seem to be present in normal cells that surround them (Gazdar, 1994; Gazdar and Minna, 1999), and we have been unable to demonstrate that these normal cells express peptides such as vasopressin. The APUD concept also does not explain the capacity of small-cell tumors to simultaneously express many neuropeptides as well as their receptors. While there has been a

growing disenchantment among cancer researchers and endocrinologists with the APUD concept as it applies to tumors, it continues to be a focus for interpretation, like the proverbial "pink elephant" of alchemy.

As an alternative to the APUD concept, a very different and new concept is now advanced by this author that peptide-producing tumors do not originate from 'neuroendocrine' cells, but that expression of a particular peptide (e.g. vasopressin, bombesin, VIP) gene is part of a special process of oncogenic differentiation representing one important part of the selective transformation of cells towards maximizing survival and growth. This is defined as the **STEPS** (**S**elective **T**umor gene **E**xpression of **P**eptides essential for **S**urvival) concept. Support for this STEPS concept includes the finding that unlike many neuroendocrine cells, peptide-producing tumors not only express peptide genes, but also express the genes for the receptors through which these peptides are known to influence tumor growth and mobility. This combined expression of peptide gene and receptor gene(s) is the now generally recognized 'autocrine growth loop' of these tumors. Additionally, it is quite likely that a single tumor cell expresses genes for multiple peptides, and therefore genes for multiple receptors for each of these peptides. Apparently there is some advantage for these tumors to produce smaller amounts of many peptide growth factors rather than a large amount of one single peptide growth-modulating agent. Perhaps this property provides a further survival advantage to the tumor as it conforms to the general pattern of growth promotion within multicellular organisms, i.e. many factors (peptides and steroids) acting interdependently over time to achieve the goal of growth.

WHAT ARE THE CLINICAL SIGNS OF VASOPRESSIN GENE EXPRESSION BY TUMORS AND WHAT LESSONS DO THEY PROVIDE

Tumor production of vasopressin in patients has long been thought to be *autonomous* implying unregulated or poorly regulated gene expression, and this seems to be in marked contrast to the rather strictly controlled and regulated production of this peptide by hypothalamic neurons that takes place under normal physiological conditions. Arginine vasopressin is the antidiuretic hormone in man and as such is an important principle for controlling fluid and electrolyte balance chiefly through the recovery of water from the kidneys (Van den Valden, 1913). Gene expression as well as release of vasopressin is regulated through hypothalamic osmoreceptors that sense plasma osmolality, and through volume receptors and baroreceptors that sense blood volume and pressure (Verney, 1947; Poulain, 1983; Sladek, 1983;). Osmotic stimulation of vasopressinergic neurons appears to involve cholinergic innervation with activation of nicotinic receptors and possibly also the actions of angiotensin II through one of its receptors. A negative feedback control of these neurons via volume receptors and baroreceptors seems to require the transmitter norepinephrine (Sladek, 1983).

The clinical symptoms in patients that point to the ectopic production of vasopressin by a tumor became known as the syndrome of inappropriate secretion of antidiuretic hormone (SIADH) through the work of Bartter and Schwartz in 1967. SIADH refers to a condition of hyponatremia and comparatively high urine osmolality, consistent with excessive retention of water by individuals with these tumors. The condition was originally associated with small-cell lung cancer, but has now been reported for breast cancer, ovarian cancer, prostatic cancer, and head and neck cancer (Kimura et al., 1986; Osterman et al., 1986; Hellstrom et al., 1991; Kavanagh et al., 1992; Talmi et al., 1996; Ferlito et al., 1997; Friedmann and North, unpublished data). While the inappropriately high circulating levels of vasopressin in these patients (North, 1991; Johnson et al., 1997) does not necessarily mean that tumor production of peptide is autonomous, or non-

controlled, it nevertheless indicates production is not tightly regulated as occurs with vasopressin of hypothalamic origin.

The induction of SIADH shows that at least some reasonable percentage of the material being produced by the tumors ends up in a biologically active form (Sawyer, 1967), even though the clinical condition might not be entirely due to elevated vasopressin (North, 1991; North et al., 1993ab). This then implies that tumors not only express the gene for vasopressin, but also genes for all of the processing enzymes necessary for generating active hormone from provasopressin, and seemingly all of the machinery necessary for moving translated protein into secretory vesicles for transport to the plasma membrane where products are exocytosed. The processing of provasopressin in neurons is known to involve at least five enzymes (North, 1987): one or two prohormone convertases (certainly PC 2 and possibly PC 1/3) that liberate a dodecapeptide from the prohormone leaving behind a glycosylated proneurophysin (Zhou and Mains, 1994; Scopsi et al., 1995; North et al., 1982), one or two carboxypeptidases (CPE as a major influence and possibly a CPD as a minor influence) in removing two basic residues from the liberated dodecapeptide to form a decapeptide (Song and Fricker, 1995a, 1995b), a peptidylglycine α -amidating monooxygenase (PAM) enzyme first described by Bradbury et al. (1982) and later extensively studied by Eipper and coworkers (Husten and Eiper, 1991) that removes and converts a C-terminal glycine residue of the decapeptide to glyoxylic acid while adding an amide to complete the vasopressin nonapeptide, and a renin-like enzyme originally described by us and called proneurophysinase that splits proneurophysin into vasopressin-associated neurophysin and vasopressin-associated glycopeptide and is also responsible for generating different metabolic forms of neurophysins (North et al., 1977, 1980, 1982, 1983).

Data from the study of plasma vasopressin and neurophysins in patients with cancer (North, 1991) point to vasopressin-production being a fixed and poorly regulated characteristic of tumors, and one not even being markedly influenced by changes of cells to more drug-resistant

forms, such as those associated with the generation of variant small-cell lung cancer from classical small-cell lung cancer (Carney et al., 1985). This has led us to adopt the saying, "once a vasopressin producer always a vasopressin producer", although we recognize that the major end-products of vasopressin gene expression in these tumors might not always be biologically effective hormone. By measuring the levels of circulating vasopressin or neurophysin in any one patient, with localized or metastatic disease, it is therefore possible to obtain information about changes in tumor size. A fall in elevated levels seems to be correlated with a positive response to treatment, and a continuous rise to progressive disease. A rise in plasma hormone/neurophysin levels from those occurring during remission appears to forecast recurrent disease (North et al., 1980; North, 1991). If these data are further substantiated by future studies, it is very likely that *in patients* gene expression for the production and secretion of vasopressin gene-related products by tumors is chiefly *unregulated* with any regulation being restricted to a fine tuning of output, rather than representing a major variable in the appearance of these substances.

WHAT TYPES OF CANCER EXPRESS THE VASOPRESSIN GENE

Originally only small-cell (oat-cell) carcinoma and carcinoids were recognized as having 'neuroendocrine' properties that included the production of a variety of peptides and the formation of secretory vesicles wherein such peptides were presumably processed (Beardwell, 1972; Sawyer, 1967; Hamilton et al, 1972, 1975; Legros, 1973; Cuttita et al., 1985; Gewitz and Yalow, 1974; Getjer et al., 1990; Rees, 1975; Whitlaw, 1969). However, this is a property now known to be shared by many tumors. Vasopressin has also been shown to be produced by prostatic and testicular tumors, ovarian cancer, pancreatic cancer (North et al., 1983a; Maurer et al., 1983; Friedmann et al., 1992) pituitary adenomas (Kimura et al., 1986) and gangliogliomas (Fehn et al., 1998), an olfactory neuroblastoma (Osterman et al., 1986), breast and colon tumors (Hellstrom et al., 1990; North et al., 1993b), a nasopharyngeal carcinoma (Kavanagh et al., 1992), cancer of the head and neck (Talmi et al., 1996; Ferlito et al., 1997)), pheochromocytoma (Grazzini, 1999) and

tumors of gastrointestinal origin (Friedmann and North, unpublished). However, only a very small percentage of squamous-cell carcinomas, adenocarcinomas, and large-cell carcinomas of the lung seem to produce vasopressin (North et al., 1983a; Maurer et al., 1983, Friedman et al., 1993). This selective high expression of vasopressin by small-cell tumors among lung cancers is the subject of discussion later in this review.

INCIDENCE OF VASOPRESSIN GENE EXPRESSION BY SMALL-CELL LUNG CANCER AND BREAST CANCER

Expression of the vasopressin gene appears to be a universal feature of both small-cell lung cancer and breast cancer (Friedmann et al., 1993; North et al., 1993abc; 1995). We have now demonstrated this to our satisfaction using a combination of immunohistochemistry, Western analysis, RIA, and RT-PCR with sequencing confirmation. This gene expression is shared by both primary and metastatic forms of these diseases and all evidence points to expression continuing throughout the lifetime of each tumor. Alternatively, expression of some other 'neuroendocrine' markers (Pinson et al., 1997) can be lost in small-cell lung cancer, particularly when the tumors dedifferentiate from classical to drug-resistant variant forms (Aisner et al., 1990; Gazda, 1994).

Small-cell lung Cancer

Immunohistochemical evaluation of small-cell lung cancer using four preparations of antibodies directed against different regions of the vasopressin precursor (Figure 1), was performed on 24 pathologically documented small-cell tumors. Of the antibodies used: one preparation of rabbit polyclonal antibodies recognizes the vasopressin (VP) moiety of provasopressin; another polyclonal antibody preparation recognizes a decapeptide sequence encompassing the tripeptide bridging structure (ProVP) of the precursor protein; an affinity

purified IgG_{2a} monoclonal antibody (NAb1) recognizes an N-terminal region of the neurophysin (NP) moiety; and a preparation of polyclonal antibodies recognizes components in the C-terminal region (18 aa) of vasopressin-associated glycopeptide (VAG). These regions of the vasopressin precursor represent exon A (VP and ProVP), exon B (NP), and exon C (VAG) of the three-exon vasopressin gene.

All 24 of 24 tumors (100%) gave positive staining with antiVP and antiProVP; 16 of the 24 tumors (67%) were immunoreactive with all four antibodies; 19 of the 24 tumors (79%) were immunoreactive with antiNP; and 20 of the 24 tumors (84%) were immunoreactive antiVAG (Table 1). Since, with respect to antiVPs and antiProVPs, 100% of the 24 tumors examined were positive by this technique for the expression of the vasopressin gene, then using 95% confidence limits, there is a positivity rate of greater than 87% that all small-cell lung cancers express this gene.

Tumors initially found to lack immunoreactivity with NAb1 in immunohistochemistry, were later demonstrated to give positive staining with polyclonal IgG_{2b} antibodies raised against vasopressin-associated human neurophysin (VP-HNP). Moreover, Western analysis (using all of the above antibodies including Nab1) performed on acid extracts from an additional six small-cell tumors, from nine cell-lines derived from classical and variant small-cell lung cancer (UMC5, UMC19, UMC31, NCI H69, NCI H82, NCI H146, NCI H345, NCI H446, DMS 53), and from mouse tumor xenografts generated from three of these cell-lines, revealed the presence of prominent immunoreactive proteins at 10 KDa, 20 KDa and 40-45 KDa, and minor ones at 32 KDa and 30 KDa in all cases. Therefore Western analysis provides additional evidence for universal vasopressin gene expression by small-cell lung cancer.

RIAs for VP and VP-HNP (North, 1991), and for VAG (North, unpublished), conducted on plasma from patients with small-cell lung cancer support the conclusion that at least the vast

majority of these cancers express the vasopressin gene. They clearly show that vasopressin gene-related products are secreted by most small-cell lung cancers. When used in combination, our data suggest plasma assays for VP, VP-HNP, and VAG can be used to monitor treatments in most patients (>70%), because one or more of the substances is elevated (>3 times) in pretherapy samples. We have shown that remission is accompanied by a fall in elevated plasma levels, and recurrence by a rise. Therefore, all of the data support the conclusion that vasopressin gene-related products (VP, VP-HNP, VAG, ProVP) can be regarded as universal lineage markers for small-cell lung cancer.

Breast Cancer

To determine expression in breast cancer, immunohistochemistry has been performed on 23 of these cancers representing a variety of tumor subtypes using the same antibody regimen directed against different moieties of the vasopressin precursor structure and indicated in Figure 1. Western Blot analysis was performed on protein extracts from an additional 12 breast tumors.

As shown in Table 2, while VP-related proteins were not detected in normal breast tissues, immunohistochemistry revealed the presence of VP, ProVP, and VAG in the cells of all tumor tissues examined. However, VP-HNP was evident in only one of 19 tumors examined.

Western blot analysis for all 12 fresh-frozen tumor samples examined showed the presence of two prominent proteins of 42 KDa and 20 KDa, that were both immunoreactive with, not only antibodies against VP and VAG, but also those against VP-HNP (insufficient anti-ProVP was available for use in this manner). We believe this positive reaction with anti-VP-HNP compared with negative immunostaining is due to decreased demands on structural stringency of the Western analysis technique, and it suggests one or a limited number of substitutions could have occurred

in the neurophysin moiety of breast cancer vasopressin precursor. The vasopressin precursor of hypothalamic tissues is 20 KDa in size.

Our findings provide evidence that the vasopressin gene is expressed as a selective feature of all breast cancers. This expression apparently gives rise to an abnormally large vasopressin-related protein(s), and one protein of a size compatible with it being the normal prohormone, possibly containing one or more modifications in the neurophysin region to make it less immunoreactive with anti-VP-HNP.

Breast Fibrocystic Disease

In order to examine if vasopressin gene expression was a possible predictor of disease, we performed a survey of the incidence of vasopressin gene expression in breast fibrocystic disease (Fay et al., 1999). In this study, we used immunohistochemistry and antibodies against vasopressin (ant-VP) and vasopressin-associated glycopeptide (anti-VAG) to examine formalin-fixed biopsy specimens taken from 17 patients with various forms of benign breast disease, who were seen at Dartmouth Hitchcock Medical Center between 1975 and 1984. These specimens were selected without any knowledge of follow-up, and included 4 cases of atypical ductal hyperplasia, 6 cases of fibrocystic disease with intraductal hyperplasia, 2 cases of fibrocystic disease with papilloma, 1 case of fibrocystic disease with bilateral mammary hyperplasia, and 4 cases of typical fibrocystic disease. Diagnosis from pathology reports was confirmed by examining hematoxylin- and eosin-stained sections. The results of these studies are illustrated in Table 3, and demonstrate that in all cases of benign breast disease examined there was negative staining for both vasopressin and vasopressin-associated glycopeptide. They indicate that the vasopressin gene is not expressed in benign breast disease, and this is in dramatic contrast to what was found for human breast carcinoma using these same antibodies (Table 2). At the completion of the study, it was discovered that one of the individuals with benign breast disease went on to develop breast

carcinoma, and another was in remission from breast cancer. Although preliminary, these data taken together with findings for breast cancer indicate that (i) expression of the vasopressin gene is not a marker of cellular proliferation in the breast, (ii) expression of the vasopressin gene is associated with the process of carcinogenesis, and (iii) expression of the vasopressin gene is not a marker of precancerous cells in benign breast disease.

Non-Small-Cell Lung Cancer

In contrast to the universal nature of vasopressin expression by small-cell lung cancer and breast cancer, immunohistochemical screening by us of a lung tumor library with the above antibodies directed against different regions of provasopressin has now confirmed earlier claims (Friedmann, 1993) that there is a low incidence (6%) of vasopressin gene expression by the 'non-endocrine' lung carcinomas (NSCCL) constituting about three-quarters of all lung cancer and represented by squamous cell carcinoma, adenocarcinoma, and large-cell carcinoma. A possible explanation for this selective expression has recently been advanced by Coulson and coworkers (1999). These investigators describe a 199 bp segment of the vasopressin gene promotor (-157 to +42) that selectively directs up to a 5-fold higher expression of the vasopressin gene in small-cell lung cancer, with a minimal 65 bp portion of this region responsible for basal specific activity.

WHAT IS THE NATURE OF THE VASOPRESSIN GENE AND GENE PRODUCTS IN CANCER CELLS

Vasopressin generated by cancer cells seems to arise from a normal vasopressin gene. Sequencing of genomic DNA from NCI H82 small-cell carcinoma cells carried out in our laboratory (North and Du, unpublished) from 914 bases upstream of the transcription start site to 92 bases beyond the 3' end site shows the presence of one gene that is structurally normal throughout its three exons and two introns, and throughout the upstream promoter region first

extensively characterized for a case of human central diabetes insipidus by Bahnsen and coworkers (1992). These researchers referred to the 1.2 Kb of promoter plus an accompanying abnormal gene possessing a single base substitution as the mutant coseg gene because it cosegregated with a condition of central diabetes insipidus. Contrary to our findings, a vasopressin gene with a polymorphism in the nucleic acid sequence encoding the signal peptide region of pre-provasopressin has been reported by others for one small-cell lung cancer cell line. This leads to a variant signal peptide with Pro substituted for Leu in position 11 of the protein. However this polymorphism seems to be an isolated case rather than a common finding for small-cell carcinoma (Shoji et al., 1997).

Cancer cells have been noted to generate some unusual vasopressin gene-related proteins (North et al., 1983a; Rosenbaum et al., 1989; North et al., 1993c), and we have been interested to discover if these proteins can be accounted for by abnormal mRNAs being transcribed from the vasopressin gene of these cells. Extensive RT-PCR, cloning, and sequencing studies were therefore performed by us employing eleven different primers. While some abnormal mRNAs were found, it is perhaps more significant to note that all of the cell lines studied contained vasopressin mRNA structurally identical to hypothalamic mRNA. Our completed sequencing of the two normal-sized VPmRNAs from NCI H82 small-cell lung cancer cells has shown while one of these has sequence identity to the VPmRNA found in hypothalamic neurons (Mohr et al., 1985), a second (Genebank Acc. No. AF031476) has a single base change (G to A) in the Exon B region, giving rise to a single amino acid substitution at position 29 of the provasopressin structure (Gly to Asp). This base substitution seems to arise as an error of transcription because repeated genomic DNA sequencing has failed to turn up a base substitution in this region. The position of this base change is particularly interesting because it occurs in the same position as a genetic point mutation in humans with inherited central diabetes insipidus (Mohr et al., 1985, Bahnsen et al., 1992), and in the same position where a genetic point difference occurs in some vertebrate species (Heierhorst et al., 1990).

Some tumor vasopressin mRNAs were encountered that were marginally (70-100 bases) larger than normal mRNA, and these are thought to be the products of alternative splicing (North et al., 1993a). More recently, we were able to show for the first time a very enlarged form of vasopressin mRNA is transcribed by NCI H82 small-cell lung cancer cells and, unlike normal mRNA, this enlarged form contains a substantial amount (> 715 bp) of the upstream promoter of the mutant coseg human vasopressin gene (North and Du, unpublished). This was demonstrated through RT-PCR performed on poly(A)+RNA using a forward primer located within the promoter region (coseg gene location 401-420) and a reverse primer located within the Exon A (coseg gene location 1235-1255) which amplified a product of 855 bp. Cloning, then sequence analysis of this product showed it was completely identical to the sequence of the 5' non-translated region of the mutant coseg gene and to the Exon A region of both this and the non-diabetic (normal) gene. We have entered the structure of this enlarged tumor mRNA into the Genbank under Accession No. AF031475. We have not yet determined a total size for this tumor mRNA, nor if it could account for some or any of the abnormal vasopressin gene-related proteins produced by small-cell lung cancer cells.

We have also examined the possibility that cross-over occurs between vasopressin and oxytocin genes by performing RT-PCR on polyA+RNA preparations from small-cell lung cancer and breast cancer cells with mixed primers for vasopressin and oxytocin structures. Morris et al. (1995) were able to show such cross-over of vasopressin and oxytocin genes can occur in hypothalamic neurons, and our studies on plasma levels of hormones and neurophysins for patients with small-cell lung cancer (North, 1991) suggested this as a possibility. Using this approach, in no case examined were we able to demonstrate any evidence that cross-over between these two genes occurs in cancer cells. While our data does not rule out that such cross-over can occur in cancer cells, they do suggest this event does not occur with a high frequency.

It is important to emphasize that some of protein products produced by all cancer cells examined are normal. Tumor produced vasopressin has been shown to have anti-diuretic activity, be eluted with synthetic peptide from HPLC gradient chromatography, and to have the same electrophoretic mobility (Sawyer, 1967, Klein et al., 1969; North et al., 1983a; North, unpublished). Vasopressin-associated human neurophysin (VP-HNP) and vasopressin-associated glycopeptide (VAG) of sizes, electrophoretic mobilities, having antigenic determinants, and mobilities on HPLC gradient chromatography, and seemingly identical to those from human posterior pituitary are also produced by cancer cells (North et al., 1983a; 1991; 1993ab). One very prominent form of protein always produced seems to be identical to 20 KDa provasopressin of hypothalamic neurons. This protein reacts with antibodies against vasopressin, VP-HNP, VAG, and the bridging region between vasopressin and neurophysin in provasopressin. It also has the same mobility in gradient HPLC as provasopressin from hypothalamic neurons.

Tumors also generate abnormal protein products. These products have molecular sizes from 30 to 45 KDa, and when isolated through immunoprecipitation or antibody-affinity chromatography, react with antibodies to vasopressin, VP-HNP, and VAG, indicating they contain at least portions of the structures of these components of provasopressin. They do not seem to be the products of associations between two provasopressins or between provasopressin and other proteins because SDS-electrophoretic profiles are not changed with reducing agents. Attempts to obtain N-terminal sequence data by Edman degradation for these proteins have so far been largely unsuccessful possibly because some of them have a blocked N-terminus. Another complication in interpreting the nature of large protein forms produced by cancer cells have come our studies using antibodies to HLA-class 1 protein. The studies of Geenan et al. (1993) point out that thymus generated proteins of approximately 40 KDa contained epitopes of neurophysin and of the HLA-class 1 heavy chain associated with β -globulin. We discovered that some of the 40 KDa protein isolated with neurophysin antibodies from NCI H82 small-cell lung cancer cells reacted with a mouse monoclonal antibody recognizing HLA-class 1 protein. When 40 KDa protein was isolated

using this HLA-class I monoclonal antibody it was found to react with antibodies to vasopressin-associated neurophysin, and Edman degradation performed on this 40 KDa protein isolated with neurophysin antibodies revealed an N-terminal sequence from the HLA-class I protein (North, unpublished). It is therefore conceivable that some vasopressin-related proteins of 30-45 KDa that are produced by cancer cells constitute a mixture of products, at least one of which shares some structural features with the HLA-class I protein.

Most of these vasopressin gene-related proteins, both 20 KDa and 30-45 KDa proteins, become components of the plasma membrane of cancer cells, and we have named these membrane-associated proteins, *neurophysin-related cell-surface antigen* (NRSA) in small-cell lung cancer and *glycopeptide-related cell-surface antigen* (GRSA) in breast cancer. This different naming applied to the products of small-cell lung cancer and breast cancer cells reflects our inability at this time to determine if these products for the two cancers are identical.

GENES FOR PROCESSING ENZYMES ARE EXPRESSED IN CANCER CELLS

Cancer cells appear to be capable of expressing those enzymes considered essential for the intravesicular processing not only of provasopressin, but also of most other proneuropeptides. The cancer cell lines NCI H82, NCI H69, MCF7 and ZR-75-1 were examined for the expression of mRNAs for the processing enzymes carboxypeptidase E (CPE), prohormone convertases PC2 and PC1 (or PC3), and PAM, using RT-PCR, cloning, and sequencing (North and Du, 1998; Du and North, 1999).

RT-PCR studies on CPE and PAM provided amplified products of the size predicted from previously published studies on anterior pituitary cells using RNA from all four cell lines. These products were reamplified, cloned and sequenced to provide structures identical to those published for these enzymes. In studies on PC2 we were able to amplify a product from NCI H69, NCI

H82, and MCF7, but not from ZR-75. We then investigated if mRNA for PC1/3 was expressed in cancer cells and were able to show that this mRNA was expressed in both small-cell lung cancer cell lines but apparently not by either breast cancer cell line. However, through Northern analysis and immunohistochemistry, other investigators (Scopi et al., 1995; Mibikay, 1997) have demonstrated that several other prohormone convertases are expressed by both small-cell lung cancer and breast cancer cells. For our studies we were able to confirm RT-PCR findings through Western analysis of proteins using antibodies against CPE, PC1, PC2, and PAM. These antibodies were provided to us through the generosity of Dr. Lloyd Fricker of Albert Einstein Medical School (Song and Fricker, 1995a), and of Drs. Betty Eipper and Richard Mains of Johns Hopkins (Husten and Eipper, 1991; Zhou and Mains, 1994). Additionally, we were able to demonstrate proneurophysinase activity in small-cell lung cancer cells (North, unpublished). Our results therefore show at least some cancer cells express the enzymes necessary for processing provasopressin to active hormone, neurophysin, and glycopeptide. This finding supports conclusions expressed above that a failure of cancer cells to process a significant amount of vasopressin precursor proteins in the same manner as central neurons is probably due to differences in sub-cellular packaging rather than to an absence of any of the enzymes necessary for processing.

THE NATURE OF SUBCELLULAR TRAFFICKING IN CANCER CELLS

Very little is known about the manner in which vasopressin gene products are processed in cancer cells. While small-cell lung cancer cells were earlier characterized by the presence of typical 'neurosecretory vesicles' associated with hypothalamic production of vasopressin, many of these tumors have very few of these vesicles (North et al., 1993ab). In an electronmicroscopic study of NCI H69 small-cell lung cancer cells, using immunogold labeling with our NAb1 monoclonal antibody to VP-HNP, Friedmann (Friedmann and North, unpublished) demonstrated a scant cytoplasm containing mitochondria but lacking significant numbers of dense-core granules.

Immunogold labeling was evenly scattered throughout this cytoplasm, with some localization of particles at the plasma membrane. This finding indicates that, at least for this cell line, most post-translational processing of provasopressin is outside of typical secretory granules.

Sucrose-gradient sub-fractionation studies performed by us on the variant small-cell lung cancer cell line NCI H82 and the breast cancer cell line ZR-75, with evaluation by Western analysis and by RIA (VP, VP-HNP, VAG), revealed that approximately 80% of both the 20 KDa and 40 KDa proteins are located in the plasma membranes of these cells. Of the remaining 20%, most (90%) is found outside typical secretory granules, and approximately 10% is within these granules. The procedures employed were earlier found by us (North et al., 1983b) to preserve granules of hypothalamic neurons from the rat with >90% of vasopressin gene-related products located in the granular fraction. Hence, either the granules of cancer cells are more susceptible to rupture, or (as is more likely) only a small percentage of translated protein is processed to active hormone within these granules and then secreted. It implies that formation of secretory granules is limited and most vasopressin-related protein in SCCL cells is destined for targeting to the plasma membrane through vesicular budding from Golgi or preGolgi structures. Both 20 KDa and approximately 40 KDa proteins were found in the granular fraction of NCI H82 cells. This indicates that structural features of 32-45 KDa proteins do not predestine them to follow a subcellular route different from that followed by normal provasopressin in these cancer cells.

Provasopressin has a single site for N-glycosylation, and the form packaged in the Golgi apparatus contains a completed carbohydrate chain of approximately 3000 daltons with fucose addition as the chain termination step. The 32-45 KDa proteins also contain this N-glycosylation site, and most probably a similar carbohydrate side-chain. Endoglycosidase H digestion of the 20 KDa and 32-45 KDa proteins of NCI H82 small-cell lung cancer cells only marginally altered the molecular sizes of these proteins in Western profiles following SDS-electrophoresis. This is taken as evidence that an abnormally large carbohydrate moiety is not a major contributor to the

molecular size of the 32-45 KDa proteins and that normal trafficking and processing between the rough and smooth endoplasmic reticulum is available for translated proteins in cancer cells.

In order to properly appraise the data obtained by us on trafficking in long-term cultures of cancer cells, it is worth noting there is general acknowledgement by researchers in this field of a gradual decrease in the level of secretion of biologically active peptide forms with length of time in culture. While we have found cells in short-term culture still direct much of their protein into the plasma membrane and these protein surface antigens are available on tumors in patients for targeting with antibodies (North et al., 1989; 1993abc), it is very possible a much higher percentage of product (i.e. biologically active vasopressin), than the 1-2% mentioned above, is secreted by tumors in patients.

ALL VASOPRESSIN RECEPTOR GENES ARE EXPRESSED BY CANCER CELLS

We have recently discovered that both small-cell lung cancer cells and breast cancer cells, not only express the vasopressin gene, but also express genes for all three recognized vasopressin receptors, and also for a human form of VACM (HVACM, human vasopressin-activated calcium mobilizing) protein, or Cullin 5 (North et al., 1998; North et al., 1999; Longo et al., 1996). It had been earlier assumed by other investigators that small-cell lung tumors express only a single vasopressin receptor subtype, namely the V_{1a} receptor, and that variant forms of this disease might lose the capacity to produce neuropeptide growth factors (e.g. vasopressin) and/or their receptors to explain a refractiveness of such cells to induced Ca^{2+} mobilization (Bunn et al., 1994). Contrary to this view, we determined that, at the mRNA and protein levels, in an addition to the three vasopressin receptors plus HVACM protein, an abnormal form of the vasopressin V_2 receptor was generated in both types of cancer cells. Vasopressin V_{1a} , V_{1b} , and V_2 receptors have

now been demonstrated by us to occur in classical NCI H345, NCI H69, NCI H146, DMS-53, and variant NCI H82 small-cell lung cancer cells, and in BT 549, MCF-7, MB-231, T47D, and ZR-75 breast cancer cells. We have also obtained sequences for the entire reading frame (ORF) of mRNAs for the vasopressin V_{1a} receptor, V_{1b} receptor, and V_2 receptor in NCI H345 and NCI H82 small-cell lung cancer cells and MCF-7 and ZR-75 breast cancer cells. These sequences have been recorded by us in the Genebank under Accession No. AF030625, AF030512, AF030626, and AF032388. The sequences obtained for vasopressin V_{1a} and V_{1b} receptors from all of these four cell lines were identical to those previously described for non-cancer cells (Sugimoto et al., 1994; Thibonnier et al., 1994; Hirasawa et al., 1994; de Keyser et al., 1994).

Two forms of vasopressin V_2 receptor mRNAs were found in cancer cells. One of these had a sequence identical to that found by us and others for the receptor of normal human tissues (Birnbaumer et al., 1992; Fay et al., 1998). The other was an enlarged form and found to contain the entire 106 bases of intron 2 in addition to the sequence for V_2 receptor mRNA. Classical small-cell lung cancer cells and breast cancer cells have both forms of vasopressin V_2 receptors, but only the abnormal form was found to be present in variant NCI H82 small-cell lung cancer cells. Inclusion of intron 2 introduces a stop codon into the reading frame and therefore the abnormal vasopressin V_2 receptor mRNA is predicted to give rise to a C-terminally truncated protein, similar (but not identical) to that found in inherited nephrogenic diabetes insipidus and referred to as the "Utah" type (Rosenthal, 1994). Both proteins lack the seventh transmembrane section and carboxyl tail of the normal receptor. We have demonstrated this, and the other vasopressin receptor mRNAs are translated into proteins by cancer cells through Western analysis using specific antibodies (North et al., 1998; North et al., 1999). The entire ORF of HVACM has been sequenced by us for NCI H146 small-cell lung cancer cells and placed in the Genebank under the accession number of AF017061 (Longo et al., 1996).

The above finding that all vasopressin receptors can be expressed by vasopressin-producing cancer cells show the influences vasopressin (and probably other peptide mitogens) have on these cells are likely to be multifaceted, and highlight a certain amount of naiveté that has existed about the role peptides play in tumor growth and survival. Chooi et al. (1994) were able to show that ectopic vasopressin promotes the growth of mammary tumors in a transgenic animal model of the disease. Such growth-promoting actions of vasopressin are generally thought to be exercised through V₁ receptors (Bunn et al., 1992). Alternatively, Taylor et al. (1990) reported that treatment with the peptide can also produce growth inhibition of MCF-7 breast cancer cells. We have proposed this anti-growth activity of vasopressin is exercised through V₂ receptors and its capacity to activate adenylate cyclase and protein kinase A and raise cellular levels of cAMP (North et al., 1998). The likelihood of this is strengthened by the recent studies of Cassoni et al. (1998) who have shown that rises in cAMP, they attribute to oxytocin, can inhibit growth in breast cancer cells. Although the abnormal V₂receptor described for these cancer cells is not expected to be fully functional (Sadeghi et al., 1997), it may serve to dampen down, or finely tune, effects registered through normal V₂receptors because such C-terminally truncated molecules are now known to serve as negative regulators through formation of heterodimeric complexes with wild-type V₂ protein (Zhu and Wess, 1998).

WHAT ARE THE INFLUENCES OF VASOPRESSIN ON CANCER CELL GROWTH

The influence that vasopressin, over the concentration range from 0.001 μM to 10 μM , has on intracellular free- Ca^{+2} concentrations in classical SCCL tumor cells (NCI H345, NCI H146)) and variant SCCL tumor cells (NCI H82) has been investigated by us. Data was obtained from studies conducted with the fluorophore Indo-1 AM on a Facstar flow cytofluorometer. A graded increase in intracellular free Ca^{+2} was seen with vasopressin concentrations from 0.01 to 1.0 μM

in NCI H345 and NCI H146 (classical) cells, but the NCI H82 cells do not respond to concentrations of the peptide as high as 10 μM . The calcium changes recorded in these experiments were found to represent release of the ion from intracellular stores. This is generally believed to be due to the action of IP₃ on IP₃ receptors. The method of Berridge et al.(1983) was employed to examine generation of IP₃ in classical (NCI H146) and variant (NCI H82) SCCL cells in response to vasopressin (1.0 μM). For NCI H82 cells, a significant increase in IP₃ occurred following vasopressin treatment. Since this increase is similar in magnitude to that reported by others for different substances acting through the IP₃/PKC cascade, we initially concluded that the absence of an accompanying Ca⁺² effect in NCI H82 might be due to the presence of an abnormal IP₃ receptor. However, no significant effect on IP₃ levels by vasopressin was seen in NCI H146 cells, where significance rises in free-Ca⁺² were recorded. These results, taken together, then suggest that IP₃ generation and calcium mobilization can be independent and non-associated events in SCCL cells, at least as they apply to the influence of vasopressin. They imply the mitogenic influence of vasopressin on SCCL might be exercised through transduction cascades other than those involving IP₃/calcium.

Taylor et al.(1990) have previously demonstrated that vasopressin is capable of stimulating the growth of MCF7 cells in vitro, and Chooi et al.(1994) have shown that vasopressin stimulates breast cancer growth in vivo. However, the mechanism through which vasopressin is exerting this effect, and the receptors involved, remain uncharacterized. One common pathway for growth factor action is stimulation of the mitogen activated protein kinase (MAPK) cascade. Activation of MAP kinase occurs through phosphorylation by MAPKK of a tyrosine, then a threonine, on-MAPK. Using commercial antibodies against phosphotyrosyl MAPK and Western analysis, we performed an investigation of vasopressin activation of MAPK in MCF7 cells. Our results clearly show that vasopressin, and a specific vasopressin V1 agonist, induce a significant increase in phosphotyrosyl MAPK. They therefore indicate that vasopressin is inducing signaling events in breast cancer cells that could lead to cancer cell growth.

REGULATOR ELEMENTS THAT CAN INFLUENCE THE GENE EXPRESSION OF VASOPRESSIN BY CANCER CELLS

The 1.2 Kb promoter region immediately upstream from the vasopressin gene in human hypothalamic cells (Bahnsen et al., 1992) is also present in vasopressin-producing cancer cells (North and Du, unpublished, see above). This region has been conserved for different species and has been shown to contain a number of positive and negative transcriptional regulators. Verbeeck et al. (1991) originally described the inhibitory influence of glucocorticoids on the expression of vasopressin by GLC-8 small-cell lung cancer cells. This negative influence of glucocorticoids on VP mRNA levels, was found to extend to vasopressin and neurophysin production in other cancer cells in the form of decreased expression by dexamethasone and increased expression by the glucocorticoid antagonist RU 486 (North and Yu, 1993b; Friedmann et al., 1995). The 1.2 Kb vasopressin gene promoter region and accompanying vasopressin gene are represented in Figure 2. This gene promoter is found to contain a GRE element for binding of activated glucocorticoid receptor. Recent studies by Burke and coworkers (1997) on a transgenic mouse model that expresses a bovine vasopressin transgene have localized a glucocorticoid regulatory element to the region -300 to -155 bp from the transcription start site. However, the studies of Yasumasa et al. (1997) indicate glucocorticoid receptor binding to DNA is preserved through promoter elements of the vasopressin gene that are more proximal to the gene initiation site.

Verbeeck and coworkers (1991) described a positive influence of cAMP on vasopressin gene expression in GLC-8 cells presumably through one or more CRE elements in the vasopressin promoter region, and this positive influence was also found to translate into changes of vasopressin gene-related protein levels for other cell lines (North and Yu, 1993; Friedmann et al., 1995). Similar effects were observed with epinephrine treatments (North and Yu, 1993). Iwasaki et al. (1997) later attributed a cAMP induced positive regulation within the rat vasopressin gene promoter to interactions between two CRE sequences (at -227 to -220 bp and -123 to -116 bp) and

the CREB protein. When small-cell lung cancer cells are treated not only with cAMP (or epinephrine), but also with glucocorticoid, the positive influence of cAMP (or epinephrine) on expression is enhanced several-fold instead of the effects canceling each other out. This appears to represent the cooption by a positive CRE element of a normally negative regulatory GRE element. While GR interactions seem to be primarily negative, there is evidence that positive regulatory responses can be conferred by interactions between the GRE and positive promoter elements in other systems. In this regard, a shift to a positive signal in another gene promoter has been noted to occur through changes in the levels of c-fos and c-jun transcription factors (Diamond et al., 1990). Iwasaki et al. (1997) were unable to demonstrate such a switch in GR regulation for their system and much higher concentrations of glucocorticoid. Nevertheless, a possibility for such switches emphasize the importance of placing any regulation observed for isolated systems into a context of the whole animal, even with respect to the CRE positive regulatory element(s). In this respect, for the chronically catheterized conscious rat, we found DDAVP, to be approximately 50 times more potent than AVP as a negative regulator of AVP release from hypothalamic neurons (Cheng and North, 1989). Vasopressin V₂ receptors are generally believed to act chiefly through mechanisms that raise cAMP levels in target cells.

The protein kinase C pathway does not seem to be a major player in the regulation of the vasopressin gene of cancer cells because Verbeeck et al. (1991) were unable to observe any change in expression with phorbol ester treatment up to 5 hours. This conclusion is supported by the later studies of Iwasaki and coworkers (1997). Alternatively, transfection of an activator protein 2 (AP2) DNA consensus sequence was found to probably block transcription, and it is likely that E-box structures located within 150 bp of the vasopressin gene initiation site serve as regulators of vasopressin gene expression (Burke et al., 1997).

Plasma osmolality is a major determinant in regulating vasopressin production and release from the hypothalamic magnocellular neurons. This regulation is believed to be through

osmoreceptors possessed by cells in the preoptic hypothalamus (Sladek, 1983), although changes in osmolality have also been reported to affect hypothalamic neurons directly (Sladek, 1993). It was to study direct effects of osmolality on vasopressin gene expression in neurons that Kim and his colleagues (1997) turned to a vasopressin-producing small-cell lung cancer cell line as a possible model system. They also examined the influence of endothelin 3, acetylcholine, and angiotensin II on vasopressin regulation in these cancer cells. These authors discovered that both osmolality (represented by a rise in sodium ion concentration) and endothelin 3 increased gene expression and that the elements of the vasopressin promoter involved are between -1500 and -532. The effects of angiotensin II and acetylcholine seemed to be confined to increasing vasopressin release from the cells. They have referred to the region of the promoter responsive to increased NaCl as an osmolality responsive element. Alternatively, Okazaki and colleagues (1997) have proposed that an oligo B negative Ca^{+2} regulator motif located around position -355 in the human vasopressin promoter region is hyperosmolality sensitive. However, these authors found that a rise of osmolality induced by NaCl, but not by urea, would promote increased expression through interactions between an Ref1 protein and the oligoB motif.

Recently, Clauson and her colleagues (1999ab, this meeting), have commenced studies to determine those regions of the vasopressin promoter that are responsible for the specific high expression of the vasopressin gene by small-cell lung cancer compared to an absence from most non-small-cell lung cancers and from normal bronchial epithelial cells. Through their studies they have identified a promoter region of 199 bp adjacent to the initiation site of the vasopressin gene (-157 to +42) that seems to be responsible for this tumor-specific expression. A fragment of 65 bp within the 199bp structure appeared to retain this specific activity. They have now been able to implicate an E-box element (E-box A, Figure 2) and, more significantly a neuron-restrictive silencer element (Quin, 1996) around the transcription initiation site in this regulation. An enhancer region that can link in its effects with the upstream regulator(s) was located within the intron 1 region of the gene.

SUMMARY

A **STEPS** concept is advanced that proposes neuropeptide production by tumors is an important part of a special process of oncogenic transformation rather than a preexisting condition of progenitor cells. All small-cell lung cancers and breast cancers appear to express the vasopressin gene and, this gene seems to be structurally normal in all but exceptional cases. Vasopressin gene expression in cancer cells leads to the production of both normal and abnormal forms of tumor vasopressin VPmRNA and proteins. Although the necessary post-translational processing enzymes are expressed in these cells, most processing seems to be extragranular, and most of the protein products become components of the plasma membrane. Small-cell lung cancer and breast cancer cells also express normal genes for all vasopressin receptors and produce normal VPmRNA and protein forms of the V_{1a} receptor, the V_{1b} receptor, and the VACM protein; plus both normal and abnormal forms of the V_2 receptor. Through these receptors, vasopressin exercises multifaceted effects on tumor growth and metabolism. A normal protein vasopressin gene promoter seems to be present in small-cell lung cancer cells, and this promoter contains all of the transcriptional elements known to be involved in gene regulation within hypothalamic neurons. Since these elements largely account for observed regulation of tumor gene expression *in vitro*, it is very likely that as yet unknown factors are selectively produced by tumors *in vivo* to account for the observed seemingly autonomous or unregulated production of hormone in tumor patients. Promoter elements thought to be responsible for selective vasopressin gene expression in small-cell cancer are thought to include an E-box and a neuron restriction silencer element close to the transcription start site. It is possible that transcription factors acting at these same elements can explain selective vasopressin expression, not only in small-cell tumors, but also in all other tumors such as breast cancer. By extrapolation, similar mechanisms might also be responsible for the expression of additional features that characterize the 'neuroendocrine' profile of these cancers.

REFERENCES

- Aisner, S.C., Finkelstein, D.M., Ettinger, D.S., Abeloff M.D., Ruckdeschel J.C., Eggleston, J.C. (1990) The clinical significance of variant-morphology small-cell carcinoma of the lung. *J. Clin. Oncol.* 8:402-408.
- Ang, H.L., Carter, D.A., Murphy, D. (1993) Neuron-specific expression and physiological regulation of bovine vasopressin transgenes in mice. *EMBO J.* 12:2397-2409.
- Bahnsen, U., Oosting, P., Swaab, D.F., Nahke, P., Richter, D., Schmale, H. (1992) A missense mutation in the vasopressin-neurophysin precursor gene cosegregates with human autosomal dominant neurohypophyseal diabetes insipidus. *EMBO J* 11:19-23.
- Ball, D.W., Azzoli, C.G., Baylin, S.B., Chi, D., Dou S., Donis-keller, H., Cumaraswamy, A., Borges, M., Nelkin, B.D. (1993) Identification of a human achaete-scute homolog highly expressed in neuroendocrine tumours. *Proc. Natl. Acad. Sci. USA* 90:5648-5652.
- Barter, F.C., Schwartz, W.B. (1967) The syndrome of inappropriate secretion of antidiuretic hormone. *Amer. J. Med.* 42:790-806.
- Beardwell, C.G. (1972) Immunoreactive vasopressin in human plasma and tumors. *Colloque. Hormones Pancreatiques, Hormones de L'eau and des Electrolytes:397.* Editions INSERM, Paris.
- Berridge, M.J., Dawson, C.P., Downes, J.P., Heslop, R.F., Irvine (1983) Changes in the levels of inositol phosphates after agonist-dependent hydrolysis of membrane phosphoinositides. *Biochem. J.* 212:473-482.

Birnbaumer, M., Siebold, A., Rosenthal, W., and Bichet, D.G. (1993) The human ADH receptor: the gene, the cDNA, the protein. *In*: ed. P.Gross, D. Richter, G.I. Robertson, *Vasopressin*, pp.19-31. John Libbey Eurotext, Paris.

Bradbury, A.F., Finnie, M.D.A., Smyth, D.G. (1982) Mechanism of C-terminal amide formation by pituitary enzymes. *Nature* 298:686-688.

Bunn, P.A.J. (1994) Effects of neuropeptide analogues on calcium flux and proliferation in lung cancer cell lines. *Cancer Res.* 54(13):3602-3610.

Bunn, P.A., Dienhart, D.G., Chan, D., Tagawa, M., Jewett, P. (1992) Effects of neuropeptides on human lung and breast cancer cells. *Monogr. Natl. Cancer Inst.* 13:145-151.

Burke, Z.D., Ho, M.Y., Morgan, H., Smith, M., Murphy, D., Carter, D. (1997) Repression of vasopressin gene expression by glucocorticoids in transgenic mice: evidence of a direct mechanism mediated by proximal 5' flanking sequence. *Neuroscience* 78:1177-1185.

Carney, D.N., Gazdar, A.F., Bepler, G., Guccion, J.G., Marangos, P.J., Moody, T.W., Zweig, M.H., Minna, J.D. (1985) Establishment and identification of small cell lung cancer cell lines having classic and variant features. *Cancer Res.* 45:2913-2923.

Cassoni, P., Sapino, A., Fortunati, N., Munaron, L., Chini, B., Bussolatti, G. (1997) Oxytocin inhibits the proliferation of MDA-MB231 human breast cancer cells via adenosine monophosphate and protein kinase A. *Int. J. Cancer* 72:340-344.

Cheng, S.W.T., North, W.G. (1989) Vasopressin reduces release from vasopressin-neurons and oxytocin-neurons by acting on V₂-like receptors. *Brain Research* 479:35-39.

Chooi, K.F., Carter, D.A., Biswas, S., Lightman, S., Ho, M.Y., and Murphy, D. (1994) Ectopic vasopressin expression in MMTV-Wnt-1 transgenic mice modifies mammary tumor differentiation and pathology. *Cancer Res.* 54:6434-6440.

Coulson, J.M., Stanley, J., Woll, P.J. (1999a) Tumour-specific arginine vasopressin promoter activation in small-cell lung cancer. *Brit. J. Cancer* 80:1935-1944.

Coulson, J.M., Fiskerstrand, C.E., Woll, P.J., Quinn, J.P. (1999b) Arginine vasopressin promoter regulation is mediated by a neuron restrictive silencer element in small cell lung cancer. *Cancer Res.*, In Press.

Coulson, J.M., Stanley, J., Staff, D., Woll, P.J. (1997) Evaluation of AVP and V1a receptor expression in SCLC cell lines: potential for an autocrine growth loop? *Lung Cancer* 18(S1):A599.

Cuttitta, F., Carney, D.N., Mulshine, J., Moody, T.W., Zweig, M.H., Minna, J.D. (1985) Bombesin-like peptides can function as autocrine growth factors in human small-cell cancer. *Nature* 316:823-826.

de Keyzer, Y., Auzan, C., Lenne, F., Beldjord, C., Thibonnier, M., Bertagna, X., Clauser, E. (1994) Cloning and characterization of the human V3 pituitary vasopressin receptor. *FEBS Lett.* 356:215-220.

Diamond, M.I., Miner, J.N., Yoshinaga, S.K., Yamamoto, K.R. (1990) Transcription factor interactions: selectors of positive or negative regulation from a single DNA fragment. *Science* 249:1266-1271.

Du, J., North, W.G. (1999) Breast cancer cells express key peptide processing enzymes. *Breast Cancer Res. Treat.* Submitted.

Fay, M.J., Du, J., Yu, X., North, W.G. (1996) Evidence for expression of vasopressin V2 receptor mRNA in human lung. *Peptides* 17:477-481.

Fay, M.J., Friedmann, A.S., Yu, X.M., North, W.G. (1994) Vasopressin and vasopressin-receptor immunoreactivity in small-cell lung-carcinoma (SCCL) cell lines - disruption in the activation cascade of V-1a-receptors in variant SCCL. *Cancer Letters* 82:167-174.

Fay, M.J., Mathew, R.S., Donnelly, E.M., Memoli, V.A., North, W.G. (1999) Immunohistochemical evaluation of vasopressin gene expression in benign breast disease: Preliminary Observations. *Endocrine Pathol.* In Press.

Fehn, M., Lohmann, F., Ludecke, D.K., Rudorff, K.H., Saeger, W. (1998) Ganglioglioma of the neurohypophysis with secretion of vasopressin. *Exper. Clin. Endocrinol. Diab.* 106:425-430.

Ferlito, A., Rinaldo, A., Devaney, K.O. (1997) Syndrome of inappropriate antidiuretic hormone secretion associated with head and neck cancers: review of the literature. *Annals of Otolaryngology and Laryngology.* 106:878-883.

Friedmann, A.S., Fay, M.J., Memoli, V.A. and North, W.G. (1995) Factors regulating the production of vasopressin-associated human neurophysin by small-cell carcinoma of the lung: Evaluation by computer-enhanced quantitative immunocytochemistry. *Neuropeptides* 28:183-189.

Friedmann, A.S., Memoli, V.A., North, W.G. (1993) Vasopressin and oxytocin production by non-neuroendocrine lung carcinomas; an apparent low incidence of gene expression. *Cancer Letters* 75:79-85.

Friedmann, A.S., Mallot, K.A., Memoli, V.A., Pai, S.I., Yu, X-M., North, W.G. (1994) Products of vasopressin gene expression in small-cell carcinoma of the lung. *Br. J. Cancer* 69:260-263.

Gazdar, A.F., Minna, J.D. (1999) Molecular detection of early cancer. *J. Natl. Cancer Inst.* 91:299-301.

Gazdar, A.F. (1994) The molecular and cellular basis of human lung cancer. *Anticancer Res.* 13:261-268.

Geenen, V., Martens, H., Robert, F., Benhida, A., Cormann-Goffin, N., Legros, J.J., Martial, J., Fanchimont, P. (1993) The dual role of thymic neurohypophysial-related self peptides in T cell selection: physiological and pharmacological implications. *Ann. N.Y. Acad. Sci.* 689:320-329.

Gerjer, T., Folkesson, R., Rehfeld, J.F., Monstein, H.J. (1990) Expression of cholecystokinin gene in a human (small-cell) lung carcinoma cell line. *FEBS Lett.* 270:30-32.

Gewitz, G., Yalow, R.S. (1974) Ectopic ACTH production in carcinoma of the lung. *J. Clin. Invest.* 53:1022.

Grazzini, E., Breton, C., Derick, S., Andres, M., Raufaste, D., Rickwaert, F., Boccara, G., Colson, P., Guerineau, N.C., Serradiel-le Gal, C., Gu, G. (1999) Vasopressin receptors in human adrenal medulla and pheochromocytoma. *J. Clin. Endocrinol. Metab.* 84:2195-2203.

Gross, A.J., Steinberg, S.M., Reilly, J.G., Bliss, D.P., Brennan, J., Le, P.T., Simmons, A., Phelps, R., Mulsine, J.L., Ihde, D.C., Johnson, B.E. (1993) Atrial natriuretic factor and arginine vasopressin production in tumour cell lines from patients with lung cancer and their relationship to serum sodium. *Cancer Res* 53:67-74.

Hamilton, B.P.M., Upton, G.V., Amatruda, T.T., Jr. (1972) Peptides with ADH-like activity in tumors producing the syndrome of inappropriate antidiuresis. *Endocrinol.* 88(Suppl): A-205.

Hamilton, B.P.M. (1975) Presence of neurophysins in tumors associated with the syndrome of inappropriate ADH secretion. *Ann. N.Y. Acad. Sci.* 248:153-155.

Hara, Y., Battey, J., Gainer, H. (1990) Structure of the mouse vasopressin and oxytocin genes. *Mol Brain Res* 8:319-324.

Heierhorst, J., Mahimann, S., Morley, S.D., Coe, I.R., Sherwood, N.M., Richter, D. (1990) Molecular cloning of two distinct vasotocin precursor cDNAs from chum salmon (*Oncorhynchus keta*) suggests an ancient gene duplication. *FEBS Lett.* 260:301-304.

Hellstrom, I., Beaumier, P.L., Hellstrom, K.E. (1990) Antitumor effects of L6, an IgG2a antibody that reacts with most human carcinomas. *Proc. Natl. Acad. Sci. USA* 83:7059-7063.

Hirasawa A., Shibata, K., Kotosai, K., Tsujimoto, G. (1994) Cloning, functional expression and tissue distribution of human cDNA for the vascular-type vasopressin receptor. *Biochem. Biophys. Res. Commun.* 203:72-79.

Husten, E.J., Eipper, B.A. (1991) The membrane-bound bifunctional peptidylglycine α -amidating monooxygenase protein. *J. Biol. Chem.* 266:17004-17010.

Iwasaki, I., Oiso, Y., Saito, H., Majzoub, J.A. (1997) Positive and negative regulation of the rat vasopressin gene promoter. *Endocrinology* 138:5266-5274.

Jin, X., Shearman, L.P., Weaver, D.R., Zylka, M.J., De Vries, G.J., Reppert, S.M. (1999) A molecular mechanism regulating rhythmic output from the suprachiasmatic circadian clock. *Cell* 96:57-68.

Johnson, B.E., Chute, J.P., Rushin, J., Williams, J., Le, T., Venzon, D., Richardson, G.E. (1997) A prospective study of patients with lung cancer and hyponatremia of malignancy. *Am. J. Respir. Crit. Care Med.* 156:1669-1678.

Kavanagh, B.O., Halperin, E.C., Rosenbaum, L.C., Shannon, E.M., Nilaver, G. (1992) Syndrome of inappropriate secretion of antidiuretic hormone in a patient with carcinoma of the nasopharynx. *Cancer* 69:1315-1319.

Kim, J.K., Summer, S.N., Wood, W.M., Schrier, R.W. (1996) Osmotic and non-osmotic regulation of arginine vasopressin (AVP) release, mRNA, and promoter activity in small cell lung cancer (SCLC) cells. *Mol. Cell. Endocrinol.* 123:179-186.

Kimura, N., Andoh, N., Sasaki, A., Mouri, T. (1986) Presence of neurophysins in the human pituitary corticotrophs, Cushing's adenoma, and growth hormone-producing adenomas detected by immunohistochemical study. *Amer. J. Pathol.* 125:269-275.

Klein, L.A., Rabson, A.S., Worksman, J. (1969) In vitro synthesis of vasopressin by lung tumor cells. *Surg. Forum* 20:231.

Kumagai, T., Tanio, Y., Osaki, T., Hosoe, S., Tachibana, I., Ueno, K., Kijima, T., Horai, T., Kishimoto, T. (1996) Eradication of myc-overexpressing small cell lung cancer cells transfected with herpes simplex thymidine kinase gene containing myc-max response elements. *Cancer Res.* 56:354-358.

Legros, J.J. (1975) The radioimmunoassay of human neurophysins: Contribution to the understanding of the pathophysiology of neurohypophysial function. *Ann. N.Y. Acad. Sci.* 248:283-303.

Longo, K.A., Fay, M.J., North, W.G. (1996) Evidence for the expression of a novel vasopressin-activated calcium mobilizing receptor (VACM-1) in human breast cancer and lung cancer. *Mol. Biol. Cell* 7:3761.

Maurer, L.H., O'Donnell, J.F., Kennedy, S., Faulkner, C.S., Rist, K., North, W.G. (1983) Human neurophysins in carcinoma of the lung: relation to histology, disease stage, response rate, survival, and syndrome of inappropriate antidiuretic hormone secretion. *Cancer Treat. Rep.* 67:971-976.

Mibikay, M., Sirois, F., Seidah, N.G., Chretien, M. (1997) Comparative analysis of expression of the prohormone convertases furin, PACE4, PC1, and PC2 in human tumors. *Brit. J. Cancer* 75:1509-1514.

Mohr, E., Hillers, M., Ivell, R., Haulica, I.D., Richter, D. (1985) Expression of the vasopressin and oxytocin genes in human hypothalami. *FEBS Lett.* 193:12-16.

Morris, J.F., Pow, D.V., Mohr, E., Richter, D. (1995) Production of hybrid oxytocin/vasopressin precursors and accumulation of oxytocin precursors in the rough endoplasmic reticulum of rat magnocellular neurons. *Adv. Exper. Med. Biol.* 395:49-58.

Murphy, D., Funkhouser, J., Ang, H-L., Foo, N.C., Carter, D. (1993) Extrahypothalamic expression of the vasopressin and oxytocin genes. *Ann. N.Y. Acad. Sci.* 689:91-106.

North, W.G. (1987) Biosynthesis of vasopressin and neurophysins, in *Vasopressin: Principles and Properties*, ed. D.M. Gash, D.M. and Boer G.J., pp. 175-209, Plenum Press. New York.

North, W.G. (1991) Neuropeptide production by small-cell carcinoma: Vasopressin and oxytocin as plasma markers of disease. *J. Clin. Endocrin. Metab.* 73:1316-1320.

North, W.G., Du, J. (1998) Key peptide processing enzymes are expressed by a variant form of small-cell carcinoma of the lung. *Peptides* 19:1743-1747.

North, W.G., Fay, M.J., Du, J. (1999) MCF-7 breast cancer cells express normal forms of all vasopressin receptors plus an abnormal V2R. *Peptides* 20:837-842.

North, W.G., Fay, M.J., Longo, K., and Du, J. (1998) Expression of all known vasopressin receptor subtypes by small-cell tumors implies a multifaceted role for this neuropeptide. *Cancer Res.* 58:1866-1871.

North, W.G., Fay, M.J., Longo, K.A., Du, J. (1998) Expression of all known vasopressin receptor subtypes by small cell tumors implies a multifaceted role for this neuropeptide. *Cancer Res.* 58:1866-1871.

North, W.G., Fay, M.J., Longo, K., and Du, J. (1997) Normal and functional V1 vasopressin receptors are present in both variant and classical forms of small-cell tumor cells. *Peptides* 18:985-993.

North, W.G., Friedmann, A.S. and Yu, X-M. (1993a) Tumor biosynthesis of vasopressin and oxytocin. *Ann. N.Y. Acad. Sci.*, 689:107-121.

North, W.G., Hirsh, V., Lisbona, R., Schulz, J., Cooper, B. (1989) Imaging of small-cell carcinoma using ¹³¹I-labelled antibodies to vasopressin-associated human neurophysin (VP-HNP). *Nuclear Med. Commun.* 10:643-651.

North, W.G., LaRochelle, F.T.Jr., Hardy, G.R. (1983b) Radioimmunoassays for individual rat neurophysins. *J. Endocrinol.* 96:373-386.

North, W.G., Maurer, L.H., Valtin, H., and O'Donnell, J.F. (1980) Human neurophysins as potential tumor markers for small-cell carcinoma of the lung: Application of specific radioimmunoassays for vasopressin-associated and oxytocin-associated neurophysins. *J. Clin. Endocrinol. Metab.* 51:892-896.

North, W.G., Maurer, L.H., O'Donnell, J.F. (1983a) In *Biology and Management of Lung Cancer*, ed. Greco, F.A., pp.143-169, Martin Nijhoff Publishers, Boston.

North, W.G., Mitchell, North, G.M. (1982) Characteristics of a precursor to vasopressin-associated bovine neurophysin. *FEBS Lett.* 152:29-34.

North, W.G., Pai, S., Friedmann, A., Yu, X., Fay, M., Memoli, V. (1995) Vasopressin gene related products are markers of human breast cancer. *Breast Cancer Research and Treatment* 34:229-235.

North, W.G., Valtin, H., Morris, J.F., LaRoche, F.T.Jr. (1977) Evidence for metabolic conversions of rat neurophysins within neurosecretory vesicles of the hypothalamo-neurohypophysial system. *Endocrinol.* 101:110-118.

North, W.G., Yu X. (1993c) Vasopressin mRNA and neurophysin-related cell-surface antigen (NRSA) in small-cell carcinoma. *Peptides* 14:303-307.

North, W.G., and Yu, X. (1993a) Forms of neurohypophysial peptides generated by tumors, and factors regulating their expression. *Regulatory Peptides*, 45:209-216.

Okazaki, T., Ishikawa, T., Nishimori, S., Igarashi, T., Hata, K., Fujita, T. (1997) Hyperosmolarity-induced gene stimulation is mediated by the negative calcium responsive element. *J. Biol. Chem.* 272:32274-32279.

Osterman, J., Calhoun, A., Dunham, M., Cullum, U., Clark, R., Stewart, O., Scheithauer, B., Zimmerman, E., Defendini, R., Zang, X., Robinson, A. (1986) Chronic syndrome of antidiuretic hormone secretion and hypertension in a patient with olfactory neuroblastoma. *Arch. Intern. Med.* 146:1731-1735.

Pardy, K., Adah, R.A.H., Carter, D.A., Seah, V., Burbach, J.P.H., Murphy, D. (1991) The identification of a cis-acting element involved in cyclic 3', 5' adenosine monophosphate regulation of bovine vasopressin gene expression. *J. Biol. Chem.* 267:21748-21752.

Pierce, A.G.E. (1969) The cytochemistry and ultrastructure of polypeptide hormone producing cells of the APUD series, and the embryologic, physiologic, and pathologic implications of the concept. *J. Histochem. Cytochem.* 17:303-313.

Pinson, P., Joos, G., Watrion, P., Brusselle, G., and Pauwels, R. (1997) Serum neuron-specific enolase as a tumor marker in the diagnosis and follow-up of small-cell lung cancer. *Respiration* 64:102-107.

Poulain, D.A. (1983) Electrophysiology of the afferent input to oxytocin- and vasopressin-secreting neurons. *Prog. Brain Res.* 60:39-52.

Quinn, J.P. (1996) Neuronal-specific gene expression - the interaction of both positive and negative transcriptional regulators. *Progress in Neurobiology* 50:363-379.

Rees, L.H. (1975) The biosynthesis of hormones by non-endocrine tumours: A review. *J. Endocrinol.* 67:143-174.

Rosenbaum, L.C., Neuwelt, E.A., Van Tol, H.H., Loh, Y.:P., Verbalis, J.G., Hellstrom, K.E., Nilaver, G. (1990) Expression of neurophysin-related precursor in the cell membranes of small-cell lung carcinoma. *Proc. Natl. Acad. Sci. USA* 87:9928-9932.

Rosenthal, W. (1994) Mutations in the vasopressin V2 receptor gene in families with nephrogenic diabetes insipidus and functional expression of the Q-2 mutant. *Cell Mol. Biol. (Noisy-le-grand)* 40:429-436.

Sadeghi, H.M., Innamorati, G., Birnbaumer, M. (1997) An X-linked NDI mutation reveals a requirement for cell surface V2R expression. *Mol. Endocrinol.* 706-713.

Sausville, E., Carney, D., Battey, J. (1985) The human vasopressin gene is linked to the oxytocin gene and is selectively expressed in a cultured lung cancer cell line. *J. Biol. Chem.* 260:10236-10241.

Sawyer, W.H. (1967) Pharmacological characteristics of the antidiuretic principle in a bronchogenic carcinoma from a patient with hyponatremia. *J. Clin. Endocrinol. Metab.* 27:1497-1499.

Scopsi, L., Gullo, M., Rilke, F., Martin, S., Steiner, D.F. (1995) Prohormone convertases (PC1/3 and PC2) in normal and neoplastic human tissues: their use as markers of neuroendocrine differentiation. *J. Clin. Endocrinol. Metab.* 80:294-301.

Sethi, T., Rozengurt, E. (1991) Multiple neuropeptides stimulate clonal growth of small cell lung cancer effects of bradykinin, vasopressin, cholecystokinin, galanin, and neurotensin. *Cancer Res.* 51:3621-3623.

Shoji, M., Kimura, T., Ota, K., Yamaji, T., Ishibashi, M., Ohta, M., Sasano, H., Kawarabayashi, Y., Kimura, N., Funyu, T., Mori, T., Sahata, T. (1997) Genotype analysis of preprovasopressin signal peptide in vasopressin-producing and non-producing lung tumors. *Life Sciences* 61:2561-2566.

Sladek, C.D. (1983) Regulation of vasopressin release by neurotransmitters, neuropeptides, and osmotic stimuli. *Prog. Brain Res.* 60:71-90.

Song, I., Fricker, L. (1995) processing of procarboxypeptidase E into carboxypeptidase E occurs in secretory granules. *J. Neurochem.* 65:444-453.

Song, I., Fricker, L.D. (1995) Purification and characterization of carboxypeptidase D, a novel carboxypeptidase E-like enzyme from bovine pituitary. *J. Biol. Chem.* 270:25007-25013.

Sugimoto, T., Saito, M., Mochizuki, S., Watanabe, Y., Hashimoto, S., Kawashima, H. (1994) Molecular cloning and functional expression of a cDNA encoding the human V1b vasopressin receptor. *J. Biol. Chem.* 269:27088-27092, 1994.

Taylor, A.H., Ang, V.T.Y., Jenkins, J.S., Silverlight, J.J., Coombes, R.C., and Lauqmani, Y.A. (1990) Interaction of vasopressin and oxytocin with human breast cancer cells. *Cancer Res.*, 50:7882-7886.

Terasaki, T., Matsuno, Y., Shimosato, Y., Yamagushi, K., Ichinose, H., Nagatsu, T., Kato, K. (1994) Establishment of a human small cell lung cancer cell line producing a large amount of anti-diuretic hormone. *Jpn. J. Cancer Res.* 85:718-722.

Thibonnier M., Auzan, C., Madhun, Z., Wilkins, P., Berti-Mattera, L., and Clauser, E. (1994) Molecular cloning, sequencing, and functional expression of a cDNA encoding the human V1a vasopressin receptor. *J. Biol. Chem.* 269:3304-3310, 1994.

Verbeek, M.A.E., Sutanto, W., Burbach, J.P.H. (1991) Regulation of vasopressin messenger RNA levels in the small cell lung carcinoma cell line GLC-8: interactions between glucocorticoids and second messengers. *Molecular Endocrinology* 5:795-801.

Verbeek, M.A.E., Elands, J.P.M., de Leij, L.F.M.H., Buys, C.H.C.M., Carney, D.N., Belper, G., Roebroek, A.J.M., Van de Ven W.J.M., Burbach, J.P.H. (1992) Expression of the vasopressin and gastrin-releasing peptide genes in small cell lung carcinoma cell lines. *Pathobiol* 60:136-142.

Verney, E.B. (1947) The antidiuretic hormone and the factors which determine its release. Proc. Roy. Soc. (London), Ser.B. 135:25-106.

Von den Velden, R. (1913) Die nierenwirkung von hypophysenextrakten beim menschen. Klin. Wochschr. (Berlin) 50:2083-2086.

Whitlaw, A.G.L. (1969) Ultrastructure of an oat-cell carcinoma of the bronchus producing an antidiuretic hormone. Brit. J. Cancer 23:69.

Woll, P.J. (1996) Growth factors and lung cancer. In Lung Cancer: Principles and Practice, Pass, H.I., Mitchell, J.B., Johnson, D.H. and Turrisi, A.T. (eds.) pp. 123-131. Lippincott-Raven: Philadelphia.

Zhou, A., Mains, R.E. (1994) Endoproteolytic processing of proopiomelanocortin and prohormone convertase 1 and 2 in neuroendocrine cells overexpressing prohormone convertases 1 and 2. J.Biol. Chem. 269:17440-17447.

Zhu, X., Wess, J. (1998) Truncated V2 vasopressin receptors as negative regulators of wild-type V2 receptor function. Biochemistry 37:15773-15784.

Table 1. Immunoreactivity for VP, VP-HNP, VAG, and the bridging region of proVP, in tumor specimens from 24 cases of SCCL

Cases	Percentage of Total	ProVP	VP	VP-HNP	VAG
n=16	67	+		+	+
n=1	4	+		+	-
n=4	17	+		+	-
n=3	12	±		±	±
Percentage of Total		100		100	79
				79	84

Pluses indicate positive staining, while minuses reflect an inability to detect immunoreactivity for either VP-HNP or VAG.

Table 2. Presence of vasopressin gene-related products in human breast cancer

cancer subtype	VP gene related antigens*			
	VP	ProVP	VP-HNP	VAG
Infiltrating ductal	na	na	-	+
Infiltrating ductal	+	+	-	+
Infiltrating ductal	+	+	-	+
Infiltrating ductal	+	+	+	+
Infiltrating ductal	+	+	-	+
Infiltrating ductal	+	-	-	+
Infiltrating ductal	+	+	-	+
Infiltrating ductal	+	na	-	+
Infiltrating ductal	+	+	-	+
Infiltrating ductal	+	+	-	+
Infiltrating ductal	+	-	-	+
Infiltrating ductal	+	-	-	+
Colloid	+	+	-	+
Colloid	+	na	-	+
Colloid	+	+	-	+
Colloid	+	+	-	+
Infiltrating tubular	+	na	-	+
Infiltrating tubular	+	+	-	+
Infiltrating lobular	+	na	-	+
Percentage positive	100%	79%	5%	100%

(now23/23)*

*Positive (+) or negative (-) immunoreactivity using antibody preparations and the ABC procedure. na = not attempted.

Table 3. Absence of vasopressin gene-related products from benign breast fibrocystic conditions

Subtype	VP gene-related antigens*	
	VP	VAG
Fibrocystic Disease	-	-
Fibrocystic Disease	-	-
Fibrocystic Disease	-	-
Fibrocystic Disease	-	-
Fibrocystic Disease with Intraductal Hyperplasia	-	-
Fibrocystic Disease with Intraductal Hyperplasia	-	-
Fibrocystic Disease with Intraductal Hyperplasia	-	-
Fibrocystic Disease with Intraductal Hyperplasia	-	-
Fibrocystic Disease with Intraductal Hyperplasia	-	-
Fibrocystic Disease with Intraductal Hyperplasia	-	-
Atypical Intraductal Hyperplasia	-	-
Atypical Intraductal Hyperplasia	-	-
Atypical Intraductal Hyperplasia	-	-
Atypical Intraductal Hyperplasia	-	-
Fibrocystic Disease with Intraductal Papilloma	-	-
Fibrocystic Disease with Intraductal Papilloma	-	-
Fibrocystic Disease with Bilateral Mammary Hyperplasia	-	-
Percentage Positive	0%	0%

*Positive (+) or negative (-) immunoreactivity using ABC immunohistochemistry

LEGENDS

Figure 1. Illustration depicting the structures of the vasopressin gene and protein precursor (preproVP). Regions of the precursor are blocked out against which Abs, used in studying immunohistochemistry of small-cell lung cancer and breast cancer, react. According to the structure of provasopressin, that commences with the N-terminal vasopressin, these antibodies are directed against the following residues: anti-VP (1-7), anti-ProVP (7-21), anti-VP-HNP (approx.12-50), and anti-VAG (128-145).

Figure 2. Schematic representation of the vasopressin gene and its promoter region showing transcriptional elements that appear to be involved with gene expression by cancer cells *in vitro*. Also shown are transcriptional elements believed to be responsible for the specific expression of vasopressin by small-cell lung cancer. GRE, glucocorticoid response element; CRE, cAMP response element; Oligo B, negative Ca^{++} response element that produces up regulation with increased NaCl; NRSE, neuron-restrictive silencer element.

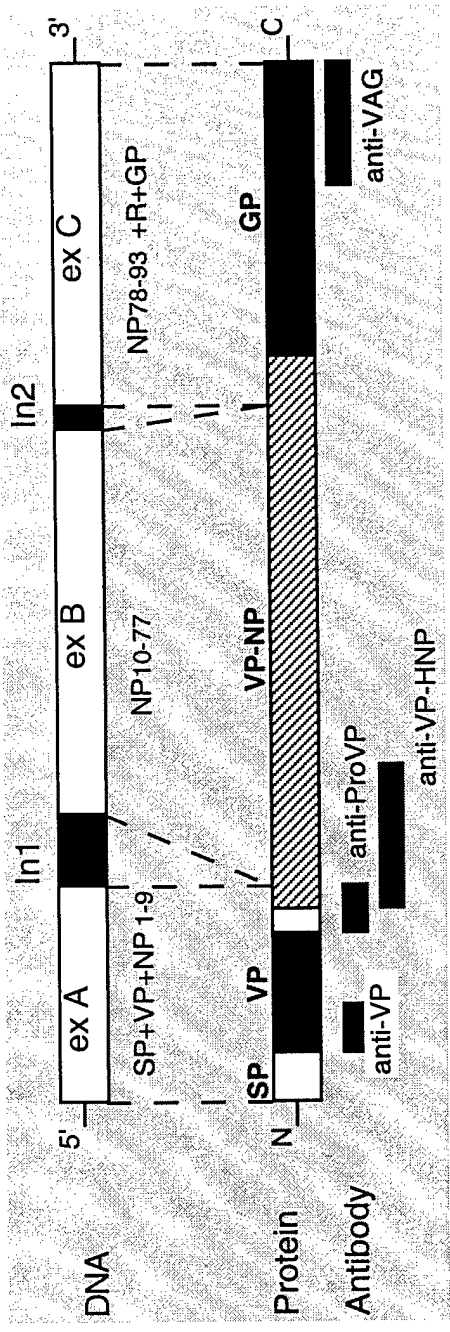

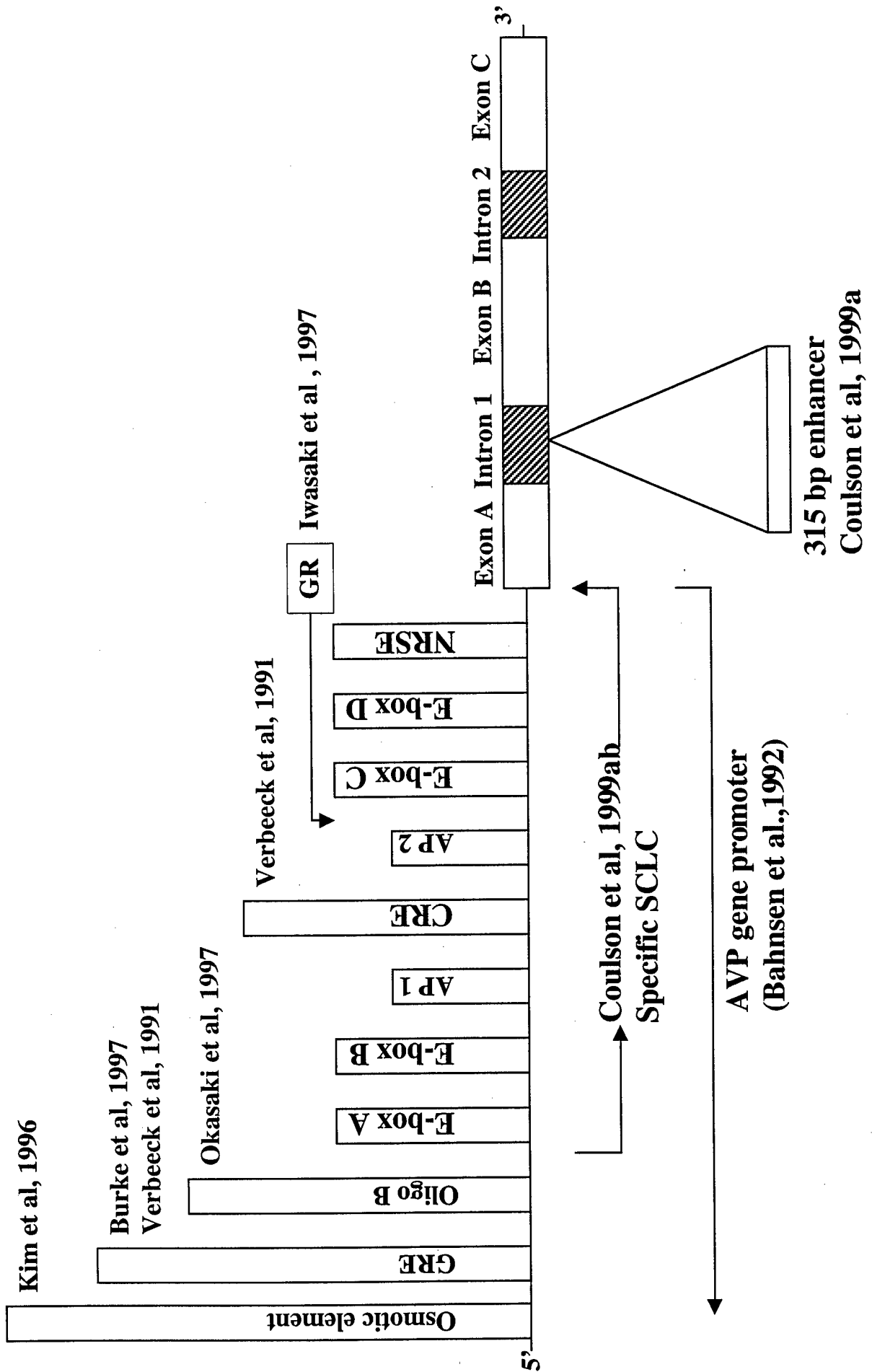

ABSTRACT MUST BE RECEIVED AT THE ASCB OFFICE BY MONDAY, AUGUST 1, 1994

THE AMERICAN SOCIETY FOR CELL BIOLOGY 1994 STANDARD ABSTRACT FORM

Circle Use Only

THIS FORM SHOULD NOT BE USED IF SUBMITTING ABSTRACT ELECTRONICALLY

DO NOT FOLD THIS FORM.

COMPLETE ALL INFORMATION REQUESTED ON THIS FORM.

Manuscript received by Monday, August 1, 1994:

- Original typed abstract form
Four photocopies of abstract form
Program Acknowledgment and Assignment Cards
Abstract handling fee - \$30

FACSIMILE COPIES WILL NOT BE ACCEPTED.

SEE PAGE 8 FOR INSTRUCTIONS.

1 E-mail address Michael Joseph Fay@ Dartmouth.EDU

Presentation Preference: Check ONE ONLY

2

POSTER ONLY

Abstract will not be considered for minisymposium.

MINISYMPOSIUM OR POSTER

Abstract will be reviewed for minisymposium. If not selected it will be programmed in a poster session.

MINISYMPOSIUM ONLY

Abstract will be reviewed for minisymposium. If not selected it will be withdrawn.

FILM SESSION ONLY

Abstract will be reviewed for a film session. If not selected it will be withdrawn. (Standard and super VHS for projection on large screen will be available in session room. Should you have a tape size other than standard or super, please contact the ASCB.)

(See page 6 for topic category list) MINISYMPOSIUM CATEGORY CODE

3
4
5

MINISYMPOSIUM TITLE

POSTER PRESENTATION PREFERENCE

(Choose 3 in order of preference from the Topic Category List. This section must be completed when submitting an abstract for POSTER ONLY or MINISYMPOSIUM OR POSTER preferences)

- 1. Code G05 Title Neurotransmitters, Peptides & Receptors
2. Code G09 Title Other
3. Code I01 Title Endocrine & Exocrine Glands

Research Area

Some of the abstract categories are very broad. To help us assign your submission to the most appropriate session, please provide a key word or phrase of up to five words that most clearly describes your research area.

7

Vasopressin, Breast Cancer neuropeptides

Not Conflict of Interest

Check if there is a possible conflict of interest in presenting this information on the part of the Author(s) or presenter, so that it may be noted in the Program. See page 8 regarding possible conflict of interest.

8

MAIL TO:

MAILING ADDRESS OF CONTACT AUTHOR (List author to be contacted for queries. Please print in black ink or type. Provide full name rather than initials)

9

Michael Joseph Fay, Ph.D.
Dartmouth Medical School
752F Borwell
Lebanon, NH 03756-0001

Phone: (603) 650-7736
Home & Holiday (603) 643-9624

Poster presenters wishing to use a VCR in the poster area must indicate below the equipment required. Presenters will be billed for the equipment in advance of the meeting.

6

- 1/2" VHS VCR (\$107.50) 19" monitor (\$60)
3/4" Umatic VCR (\$129.50) 25" monitor (\$85)

A member must sign abstract as author or sponsor. Member's name:

10

ASCB Member
Other FASEB Society Member
Check here if you are applying for ASCB lifetime Membership

Use Only



TRACT MUST BE RECEIVED BY
ASCB BY FRIDAY, JUNE 14, 1996

1996 STANDARD ABSTRACT FORM

**SEE PAGE 11 FOR
INSTRUCTIONS**

**THIS FORM SHOULD NOT BE
USED IF SUBMITTING ABSTRACT
ELECTRONICALLY**

DO NOT FOLD THIS FORM.

Following to the ASCB, Rockville Pike, Bethesda, MD
-5522; Tel: 301-530-7010
Original typed abstract form
4 photocopies of abstract form
Abstract submission fee - \$25

FACSIMILE COPIES WILL NOT BE ACCEPTED.

Session Preference: Check ONE ONLY:

POSTER ONLY
Abstract will not be considered for Concurrent Symposium.

CONCURRENT SYMPOSIUM OR POSTER
Abstract will be reviewed for a Concurrent Symposium. If not
selected it will be programmed in a poster session.

NO Conflict of Interest

Check here if there is a possible conflict of interest in pre-
senting this information on the part of the author(s) or pre-
senter, so that it may be noted in the Program. See page
1 regarding possible conflict of interest.

If presenter wishing to use a VCR in the poster area
indicate below the equipment required (electric hookup
fees included in VCR prices). Presenters will be billed for
equipment in advance of the meeting.

2" VHS VCR (\$155) 15" monitor (\$75)
 4" VHS VCR (\$200) 25" monitor (\$100)

Electric hookup only (\$55)
(If ordering monitor only,
SEE electric and SPD/labor will be added)

Foundation Award
Check here if you believe your abstract is competitive for
consideration for the Glenn Foundation Award (see page 6
for details).

CURRENT SYMPOSIUM CATEGORY CODE _____
(page 14 for topic category list.)

CURRENT SYMPOSIUM TITLE _____

TOPIC PRESENTATION PREFERENCE
(see 2 in order of preference from the Topic Category List. This section must be completed when submitting an abstract for CON-
CURRENT SYMPOSIUM OR POSTER preference.)

code G05 Title Neurotransmitters, Peptides & Receptors
code A01 Title Growth Factors & Receptors

MAILING ADDRESS OF RESPONSIBLE AUTHOR (List author to be contacted for queries or invitation/acknowledgment letter. Please
do not check ink or type. Provide full name rather than initials.)

name: Kenneth Longo
address: Dartmouth Medical School
Department of Physiology, 1 Medical Center Drive
752E Borwell, Lebanon, NH 03756

phone: (603) 650-7736 Home/office: (603) 448-7325
fax: (603) 650-6130 e-mail: Kenneth.longo@Dartmouth.edu

EVIDENCE FOR THE EXPRESSION OF A NOVEL VASOPRESSIN -ACTIVATED CALCIUM MOBILIZING RECEPTOR (VACM-1) IN HUMAN BREAST CANCER AND LUNG CANCER ((K.A. Longo, M.J. Fay, J. Du, and W.G. North)) Department of Physiology, Dartmouth Medical School, Lebanon, NH 05756

The purpose of this study was to determine if a human homologue of the rabbit VACM-1 receptor is expressed in human cancer cells. Research indicates that vasopressin may be involved in human breast cancer and lung cancer pathophysiology, as an autocrine/paracrine factor. Vasopressin can act through four classes of receptors: V2, V1a, V1b, and the recently cloned VACM-1, a structurally unique member of this group that contains a single transmembrane domain. Vasopressin induced an increase in intracellular free Ca²⁺ in the breast cancer cell lines MCF-7, T47-D, and ZR-75 as well as in the lung cancer cell line H-146. RNA from these cell lines, as well as normal human tissues (kidney and lung), was used for reverse transcription polymerase chain reaction (RT-PCR) and Northern blot analysis. RT-PCR, using two primer sets designed against the rabbit VACM-1 sequence, amplified bands of the predicted sizes of ~674 bp and ~193 bp in all cell lines and tissues tested. Direct sequencing of PCR products obtained from MCF-7 and H-146 revealed a high degree of identity to the cloned rabbit VACM-1 cDNA sequence. Northern blot analysis, using the 674 bp PCR product as a probe, revealed the presence of three distinct bands, of approximate sizes 3.5, 5 and 6.5 kilobases, in the cancer cell lines. In summary, we have demonstrated the presence of mRNA for a novel vasopressin receptor in human cancer cell lines and normal human tissues.

A member must sign abstract as author or sponsor.
Member's name: Michael J. Fay, Ph.D.

Please print
Michael J. Fay
Signature

Phone: (603) 650-7736
Fax: (603) 650-6130

The above is:
 an ASCB member
 another FASEE society member
(Specify: _____)
 a member of non-U.S. cell biology society
(Specify: _____)
 Check here if you are applying for first-time, partial-year
ASCB membership
 Check here if you are a student

**THERE IS A \$10 FEE
TO REPLACE ABSTRACTS**

Vasopressin and Breast Cancer: Gene expression and Trafficking.
William G. North, Michael J. Fay, and Jinlin Du, Dartmouth Medical School,
Lebanon, N.H. 03756 USA.

We earlier discovered that the vasopressin gene expression occurs in probably all breast cancers, that this expression apparently arises as part of the carcinogenesis process in the mammary gland, and that 40 KDa and 20 KDa vasopressin-related proteins are generated as components of the plasma membrane in breast tumor cells. We have named the membrane proteins GRSA (glycopeptide-related cell surface antigens). We have now examined aspects of vasopressin gene expression and the processing of gene-associated products in MCF-7 and ZR-75, using RT-PCR, cloning, DNA sequencing, sucrose-gradient fractionation, Western analysis, and flow cytometry. Results obtained have led us to the following conclusions:

- GRSA surface markers originate through the expression of both normal and abnormal vasopressin genes. This is because RT-PCR products of normal and increased size, as well as with normal and abnormal sequences, were obtained;
- trafficking of GRSA proteins to the cell surface is controlled by factors additional to structural elements within these proteins. This is because both abnormal 40 KDa proteins as well as seemingly normal 20 KDa provasopressin are packaged into neurosecretory vesicles;
- abnormal posttranslational processing of vasopressin-related proteins by tumor cells is not due to their inability to express intravesicular processing enzymes. This is because we were able to demonstrate that functional forms of prohormone convertase 2 (PC2) and carboxypeptidase E (CPE) are probably produced by these cells;
- GRSA proteins contain vasopressin and neurophysin structures, as well as the glycopeptide moiety of provasopressin. This is because antibodies to vasopressin, human vasopressin-associated neurophysin (VP-HNP) and vasopressin-associated glycopeptide (VAG), all react with both 40 KDa and 20 KDa protein forms, and;
- GRSA proteins can be potentially used in new immunotherapeutic treatments of breast cancer. This is because the proteins, as components of viable cells in vitro, react with specific antibodies.

63.4

PRODUCTION AND PROCESSING OF VASOPRESSIN GENE-RELATED PROTEINS BY NEUROENDOCRINE TUMORS. W.G. North* J. Du. Dept. of Physiol., Dartmouth Med. Sch., Lebanon, NH 03756.

We have discovered that vasopressin (VP) gene-related proteins are most probably universal lineage markers for not only small-cell carcinoma of the lung (SCCL), but also breast cancer. Unlike their production by neurons, most (>90%) of these proteins are not packaged into secretory vesicles by these tumor cells, but instead are trafficked to the plasma membrane where they uniquely form surface antigens (NRSA). RT-PCR, cloning, sequencing, immunocytochemistry, Western analysis, and flow cytometry, have allowed us to reach the following conclusions about these tumor proteins:

- NRSA originates from of both normal and abnormal VP genes;
- VP gene expression is a likely feature of the carcinogenic process that generates tumors such as SCCL and breast cancer;
- errors take place in transcription that probably lead to tumor-specific abnormal posttranslational processing;
- NRSA arises through both normal and abnormal posttranscriptional processing;
- trafficking of NRSA to the cell surface is controlled by factors additional to structural elements within the proteins translated;
- abnormal processing of proteins by tumors is not due to their inability to express intravesicular processing enzymes;
- changes in tumor differentiation (or drug resistance) does not affect the nature nor the degree of expression of NRSA.
- membrane models for NRSA require VP, neurophysin, and glycopeptide elements to be extracellular.

Proc. Society for Neuroscience, Volume 23, 1997

Proc. Soc. Neuro, 23:63.4A, 1997

Mail to:
 WCNH Secretariat
 Conference Office, McGill University
 550 Sherbrooke Street West, West Tower, Suite 490
 Montreal, Qc, Canada H3A 1E9

Telephone: (514) 395-3770
 Fax: (514) 398-6854
 Email: WCNH@umontreal.mcgill.ca
 Website: http://www.mcgill.ca/mco/wcnh
 Deadline for Abstract submissions: March 14, 1997

Complete the following if no address appears in the box. If there are errors, fill in correct information.

Dr. Mr. Mrs. Ms. _____

First name Kenneth

Family name Longo

Institution Dartmouth Medical School

Address 1 Medical Center Drive

City Lebanon Province/State NH Country USA Postal code / Zip 03756

Telephone (603) 650-7736 Fax (603) 650-6130 Email kenneth.longo@dartmouth.edu

Dr. Michael Fay
 Dartmouth Inst.
 Physiology Dept.
 Lebanon, NH
 U.S.A.
 03756

Abstract title Evidence for the expression of a novel vasopressin-activated calcium mobilizing receptor (HVACM) in human breast cancer and lung cancer cell lines

Authors including presenter (Please underline presenter's name)	Institutions
1 <u>Kenneth A. Longo</u>	1 <u>Dartmouth Medical School</u>
2 <u>William G. North, Ph.D.</u>	2 <u>Dartmouth Medical school</u>
3 <u>Jinlin Du, M.D.</u>	3 <u>dartmouth Medical School</u>
4 <u>Michael J. Fay, Ph.D.</u>	4 <u>Dartmouth Medical School</u>

Please submit additional authors on a separate sheet of paper
 Please type text of abstract ONLY (not title) within this frame

The purpose of this study was to determine if a human homologue of the rabbit vasopressin-activated calcium mobilizing (VACM-1) receptor is expressed in human cancer cells. Vasopressin (AVP) may be involved in human breast cancer and lung cancer pathophysiology, as an autocrine/paracrine factor. AVP can act through four classes of receptors: V2, V1a, V1b, and the recently cloned VACM-1, a structurally unique member of this group that contains a single transmembrane domain. (Recently, a highly homologous cDNA, termed HVACM, was cloned from human placental mRNA.)-AVP induced an increase in intracellular free calcium in the breast cancer cell lines MCF-7, T47-D, and ZR-75, and in the lung cancer cell line NCI H-146. Total RNA from these cell lines and normal human tissues (kidney and lung), was used for reverse transcription polymerase chain reaction (RT-PCR) and Northern blot analysis. RT-PCR, using two primer sets designed against the rabbit VACM-1 sequence, amplified bands of the predicted sizes of 674 bp and 193 bp in all cell lines and tissues tested. Direct sequencing of PCR products obtained from H-146 revealed a high degree of identity to the rabbit VACM-1 cDNA (90%) and the human HVACM cDNA (99.5%). Northern blot analysis revealed three distinct bands (3.5, 5 and 6.5 kilobases) in the cancer cell lines. In summary, we have demonstrated the presence of mRNA for a novel AVP receptor in human cancer cell lines and normal human tissues.

VASOPRESSIN GENE-RELATED PRODUCTS IN THE MANAGEMENT OF BREAST CANCER.

William G. North, Ph.D., Michael J. Fay, Ph.D.,
Kenneth Longo, B.S., and Jinlin Du, M.D.

Dartmouth Medical School, Department of Physiology,
1 Medical Center Drive, 752F Borwell, Lebanon, NH 03756

There is currently no known universal marker system for breast cancer that can be utilized in tests for early detection, for tumor localization, and for targeted treatment. Most approaches in the management of this disease depend on mammography for detection, and combination chemotherapy and radiation for treatment. We discovered that all breast cancers we examined expressed the vasopressin gene, and set out to determine if this expression represented a universal marker system for the disease. We also have commenced examining the nature of the gene-related products generated by this expression, their role in tumor growth, and their potential usefulness in developing new methods for early detection and for rational treatments. Our approach has involved employing immunohistochemistry and a battery of our antibodies directed against different regions of the provasopressin molecule, methods of protein isolation and characterization, flow cytometry, reverse transcription followed by amplification through polymerase chain reaction (RT-PCR), DNA sequencing, sucrose-gradient fractionation, and radioimmunoassay. In our studies we have utilized surgical and biopsy specimens of breast cancer, normal breast tissue, breast fibrocystic disease, and breast carcinoma in situ, and employed five breast cancer cell lines in culture.

Results obtained using immunohistochemistry have revealed that vasopressin gene-related products are very likely universal markers of early carcinogenesis in breast tissues. This is because all of 19 breast tumors examined gave diffuse positive immunostaining for different components of the provasopressin molecule, while no staining was obtained with normal breast tissues. No cases of polycystic disease examined, including typical and atypical hyperplasia, gave positive staining and this showed tumor immunoreactivity does not simply represent tissue proliferation. All cases of carcinoma in situ gave diffuse positive staining with antibodies against vasopressin-associated human glycopeptide (VAG) suggesting

Keywords: Vasopressin Gene and Carcinogenesis, Glycopeptide-Related Surface Antigen, Targeting, Vasopressin Receptors, Autocrine Growth Factor

This work was supported in part by the U.S. Army Medical Research and Materiel Command under DAMD 17-94-j-4288.

vasopressin gene expression is also common to this form of preinvasive breast cancer. Results obtained from protein analysis and sucrose-gradient fractionation studies, on breast cancer and the MCF-7 and ZR-75-1 cell lines, indicate vasopressin gene expression in breast cancer gives rise to unique major protein products of 40 KDa and 20 KDa that become components of the plasma membrane, and are largely (>90%) processed outside of secretory granules. We have named these proteins collectively GRSA (glycopeptide-related surface antigen) because for viable MCF-7 cells in culture they were found to react with our antibodies to VAG. Ongoing RT-PCR studies on MCF-7, T47D, ZR-75-1 cell lines, utilizing ten primers designed to produce cross-over products for the whole reading frame of vasopressin (VP) mRNA, have so far allowed us to deduce that GRSA proteins are the products of at least two VP mRNAs, one of normal size and presumably generated from a normal gene, the other(s) containing an additional 600 bases upstream from Exon B and generated either from a normal gene through alternative splicing that includes a portion of intron 1 or from an abnormal gene with an insertion in Exon A. In our studies we have additionally found no evidence for cross-over between vasopressin and oxytocin genes in breast cancer. Although cellular trafficking of GRSA proteins is largely outside of secretory vesicles, we have determined breast cancer cells are capable of expressing proteolytic enzymes required in normal intravesicular processing. Primer pairs for amplification of cDNA fragments of prohormone convertases (PC) 1/3 and 2, and carboxypeptidase E (CPE) were used in RT-PCR performed on RNA from cell lines MCF-7 and ZR-75-1. For CPE primers, products of the predicted size were obtained from both cell lines, and DNA sequencing gave a sequence identical to that published for functional CPE of anterior pituitary. Similarly, a product of predicted size and normal structure could be amplified using PC 2 primers from MCF-7 cells, but not from ZR-75-1 cells. Neither cell line seemed to express mRNA for PC 1/3. While most VP gene expression culminates in GRSA protein production, some of it appears to produce vasopressin and VAG as secretory products. This is because, using our RIAs, we were able to show these products elevated in the plasma of 5 of 7 patients with breast cancer. RIAs for VP and VAG might therefore find a use in methods for detecting tumors and monitoring treatments. Vasopressin (VP) appears to be an autocrine growth factor for breast cancer. In this respect, we were able to demonstrate for T47D and ZR-75-1 cells, using Indo-1AM fluorescence and flow cytometry, that the peptide can increase intracellular free-Ca²⁺ in a dose-dependent manner. We were also able to show through Western analysis that VP can activate mitogen-activated protein (MAP) kinase in these cells. Although these effects both appear to be through a vasopressin V₁ receptor mechanism, RT-PCR and DNA sequencing has been used by us to show that breast cancer cells are capable of expressing all four vasopressin receptor subtypes (V_{1a}, V_{1b}, V₂, and human VACM), as well as oxytocin receptors. BT 549, MCF-7, MDA-MB-231, T47D, and ZR-75-1 cells have featured in these receptor studies.

Our studies have therefore led us to the following conclusions: 1) the vasopressin gene is a universal marker of carcinogenesis in breast tissue; 2) vasopressin gene expression in breast cancer uniquely leads to the formation of surface GRSA proteins that are potential targets for immunotherapy; 3) breast tumors are neuroendocrine and most cause plasma elevations of vasopressin gene-related products that can be potentially used for detection and monitoring treatments; 4) vasopressin is an autocrine growth factor for breast cancer; and 5) expression of multiple VP receptor subtypes implies vasopressin plays a multifaceted role in tumor growth and survival. All of these conclusions speak to the future importance of vasopressin gene-related products for developing new and sensitive methods of detecting breast cancer and monitoring treatments, and new and successful immunotherapeutic interventions.

THE ROLE OF VASOPRESSIN AND OXYTOCIN HORMONES IN BREAST CANCER

Michael Fay, Ph.D., Jinlin Du, MD, Kenneth Longo,
and William North, Ph.D.

Department of Physiology, Dartmouth Medical School,
1 Medical Center Drive, 752E Borwell, Lebanon, NH 03756.

This laboratory has demonstrated that fixed breast cancer biopsy specimens exhibit positive immunoreactivity for vasopressin and oxytocin gene-related products using the technique of immunohistochemistry and antibodies directed against different regions of the vasopressin and oxytocin prohormones. In addition, both *in vitro* and *in vivo* research indicate that neuropeptides, like vasopressin and oxytocin, modulate breast cancer cell growth. Taken together these results suggest that vasopressin and oxytocin may serve as autocrine and/or paracrine growth modulators for breast cancer cells. However, the receptors and signal transduction pathways through which vasopressin and oxytocin act to influence breast cancer cell growth remain unknown. The purpose of this research is to determine if breast cancer cells express vasopressin and oxytocin receptors, and to evaluate vasopressin- and oxytocin-induced signal transduction in breast cancer cells.

To evaluate which vasopressin and oxytocin receptor subtypes are expressed by breast cancer cells the technique of reverse-transcription polymerase chain reaction (RT-PCR) was used with primer pairs specific for the oxytocin receptor, the V1a vasopressin receptor, the V1b vasopressin receptor, the V2 vasopressin receptor, and the vasopressin-activated calcium mobilizing receptor (VACM). The VACM and V1b receptor PCR products were confirmed by direct DNA sequencing. To study vasopressin and oxytocin induced changes in intracellular-free calcium, breast cancer cells were loaded with indo-1 AM, and neuropeptide-induced changes in intracellular free calcium monitored over a four minute period using a Becton Dickinson Facstar Plus flow cytometer [excitation 356 nm, emissions 405 nm (calcium bound indo), and 485 nm (free indo)]. To determine if vasopressin causes activation of the mitogen activated protein kinase cascade (MAP kinase), MCF-7 breast cancer cells were stimulated with vasopressin, and activated (phosphorylated) MAP Kinase evaluated by western blot analysis.

Keywords: Breast Cancer Cells, Vasopressin and Oxytocin, Vasopressin and Oxytocin Receptors, Signal Transduction.

This work was supported by the U.S. Army Medical Research and Materiel Command under DAMD 17-94-j-4131.

Using the technique of RT-PCR evidence was obtained for the expression of mRNA(s) for a number of vasopressin and oxytocin receptor subtypes in cultured breast cancer cell lines. Using two primer pairs based on the sequence of the VACM receptor, PCR products of the predicted sizes of 674 bp and 193 bp were amplified from MCF-7, T47D, and ZR-75 breast cancer cell lines. Using a primer pair based on the oxytocin receptor, a PCR product of the predicted size of 391 bp was amplified from BT549, MCF-7, MDA-MB-231, T47D, and ZR-75 breast cancer cell lines. From the ZR-75, BT549, and MCF-7 cell lines a PCR product of the predicted size of 862 bp was amplified using primers for the V2 vasopressin receptor. In addition, using the V2 receptor primers, a PCR product which is approximately 100 bp larger than expected was amplified from these three cell lines. It is believed that this PCR product represents an incompletely spliced mRNA species containing the second intron. Using Primer pairs that amplify a 239 bp PCR product for the V1b vasopressin receptor, a product of the predicted size was amplified from the MCF7 breast cancer cell line. Preliminary PCR results using a primer pair based on the V1a vasopressin receptor indicate that a PCR product of the predicted size of 408 bp was amplified from the T47D breast cancer cell line. The identity of the VACM and V1b PCR products has been verified by direct DNA sequencing of the PCR products. Northern blot analysis for VACM using RNA from the ZR-75, MCF-7, and T47D cell lines indicates RNA species of ~ 3.5, 5, and 6.5 Kb. Using indo-1 AM loaded ZR-75 and T47D breast cancer cells neuropeptide induced changes in intracellular free calcium was monitored using flow cytometric analysis. Vasopressin (0, 10 nM, 100 nM, and 1,000 nM) was administered after approximately 20 seconds of baseline. In both cell lines vasopressin at the 100 nM and 1,000 nM doses induced a rise in intracellular-free calcium as indicated by an increase in the 405nm/485nm ratio. At all the doses studied oxytocin (10 nM, 100 nM, 1,000 nM) did not cause a noticeable rise in intracellular-free calcium in the ZR-75 and T47D cell lines. Treatment of MCF-7 breast cancer cells with 100 nM and 1,000 nM vasopressin resulted in a dose-dependent increase in tyrosine phosphorylated MAP kinase as determined by Western blot analysis.

Both *in vivo* and *in vitro* results indicate that neuropeptides like vasopressin can serve as growth modulating agents for breast cancer. Research performed in this laboratory indicates that neuropeptides, like vasopressin and oxytocin, are produced by breast cancer cells. Collectively these results suggest that neuropeptide hormones may serve as autocrine/paracrine factors for breast cancer. The results obtained in these studies provide further support for a role of vasopressin and oxytocin as paracrine/autocrine factors for breast cancer since mRNA(s) for a number of receptors for these hormones are expressed in cultured breast cancer cells. Vasopressin treatment causes a rise in intracellular free calcium in two cultured breast cancer cell lines, suggesting that the hormone might be activating VACM, V1a, or V1b receptor subtypes. Experimental results obtained with the MCF-7 breast cancer cell line suggest that the influence of vasopressin on breast cancer cell growth observed *in vivo* and *in vitro* may be due to activation of the MAP kinase cascade. These results further support a role for neuropeptide hormones like vasopressin and oxytocin in breast cancer pathophysiology. Identifying hormones involved in breast cancer cell growth, the hormone receptors through which these peptides act, and the cellular changes associated with receptor activation is crucial to identifying novel strategies for the treatment of breast cancer.

#1175 Breast cancer cells express all known vasopressin receptors plus an abnormal V2 receptor. Du, J. and North, W.G. *Department of Physiology, Dartmouth Medical School, Lebanon, NH 03756.*

Vasopressin is reported to influence the growth of breast cancer cells, and we and others have provided evidence that an autocrine loop involving vasopressin is present in perhaps all breast cancers. The current study was undertaken to examine possible vasopressin receptor subtypes taking part in this autocrine loop as it exists in MCF-7 cells in culture. RT-PCR demonstrated that mRNAs for all currently recognized vasopressin receptor subtypes (V_{1a} , V_{1b} , and V_2) are expressed by these cells. Cloning, and DNA sequencing over the entire open reading frame (ORF) of each mRNA revealed that normal sequences representing each receptor were present. However, in addition to these normal structures, an abnormal mRNA for the V_2 receptor was also expressed. This contains a sequence corresponding to intron 2 of the gene and is apparently the product of incomplete splicing. Such an mRNA, also found by us to occur in small-cell lung cancer cells, would be expected to give rise to a truncated and C-terminally altered "diabetic" form of receptor protein. Western analysis revealed that all three normal mRNAs gave rise to proteins of sizes compatible with them being functional receptors. The abnormal V_2 receptor mRNA also gave rise to proteins, which are presumed to be non-functional. The presence of all three normal vasopressin receptors in these breast cancer cells that also produce vasopressin suggests the autocrine loop of the peptide in breast tumors, as in small-cell tumors, is multi-functional in nature.

LOCUS XXXXX 1298 bp mRNA PRI 08-OCT-1998
DEFINITION Homo sapiens breast cancer vasopressin receptor subtype 1a mRNA,
complete cds.

ACCESSION XXXXX

KEYWORDS

SOURCE human.

ORGANISM Homo sapiens

Eukaryota; Metazoa; Chordata; Vertebrata; Mammalia; Eutheria;
Primates; Catarrhini; Hominidae; Homo.

REFERENCE 1 (bases 1 to 1298)

AUTHORS North,W.G., Fay,M.J., Longo,K.A. and Du,J.

TITLE Expression of all known vasopressin receptor subtypes by small cell
tumors implies a multifaceted role for this neuropeptide

JOURNAL Cancer Research 58, 1866-1871 (1998)

REFERENCE 2 (bases 1 to 1298)

AUTHORS North,W.G. and Du,J.

TITLE Breast cancer cells express normal forms of all vasopressin
receptor subtypes plus an abnormal v2 receptor

JOURNAL Unpublished

REFERENCE 3 (bases 1 to 1298)

AUTHORS Du,J. and North,W.G.

TITLE Direct Submission

JOURNAL Submitted (08-OCT-1998) Physiology, Dartmouth Medical School, 1
Medical Center Drive, Lebanon, NH 03756, USA

FEATURES Location/Qualifiers

source 1..1298

/organism="Homo sapiens"

/db_xref="taxon:9606"

/note="Breast cancer cell line MCF-7;"

gene 1..1298

/gene="Breast cancer vasopressin receptor subtype 1a"

mRNA 24..1280

/gene="Breast cancer vasopressin receptor subtype 1a"

CDS 24..1280

/gene="Breast cancer vasopressin receptor subtype 1a"

/codon_start=1

/product="Breast cancer vasopressin receptor subtype 1a"

/translation="MRLSAGPDAGPSGNSSPWVPLATGAGNTSREAEALGEGNGPPRD

VRNEELAKLEIAVLA VTFVA VAVLGNSSVLLALHRTPRKTSRMHLFIRHLSLADLAVAF
FQVLPQMCWDITYRFRGPDWLCRVVKHLQVFGMFASAYMLVVM TADRYIAVCHPLKTL
QQPARRSRLMIAAAWVLSFVLS T'PQYFVFSMIEVNNVTKARDCWATFIQPWGSRAYVT
WMTGGIFVAPVVLGT CYGFICYNIWCNVRGKTASRQSKGAEQAGVAFQKGFLLAPCV
SSVKISIRAKIRTVKMTFVI VTA YIVCWAPFFIIQMWSV WDPMSVWTESENPTITTA
LLGSLNSCCNPWIY MFFSGHLLQDCVQSFPCCQNMKEKFNKEDTDSMSRRQTFYSNNR
SPTNSTGMWKDSPKSSKSIK FIPVST"

BASE COUNT 258 a 399 c 364 g 277 t

ORIGIN

1 cgagtaggag ctgatggac agcatgcgtc tctccgccgg tcccagcgcg gggccctcgg
61 gcaactccag cccatggtgg cctclggcca ccggcgtcgg caacacaagc cgggaggccg
121 aagccctcgg ggagggcaac ggcccaccga gggacgtcgg caacaggag ctggccaac
181 tggagatcg cgtcgtggcg gtgacttcg cgggtggcgt gctgggcaac agcagcgtac
241 tgctgctct gcaccggacg ccgcgcaaga cgtcccgcac gcacctctc atccgacacc
301 tcagcctggc cgaactggcc gtggcattct tccaggtgct gccgcaaatg tgctgggaca
361 tcacctaccg ctcccgcgcc cccgaclggc tgtgcccgct ggtgaagcac ctgcaggtgt
421 tcggcatgtt tgcctcggcc tacatgctgg tagtcatgac agccgaccgc tacatcgcgg
481 tgtgccacc cgtcaagact ctgcaacagc ccgcgcgcc ctcgcgctc atgatcgcgg
541 ccgcctgggt gctgagcttc gtgtgagca cggcgagta ctctcttc tccatgatc
601 aggtgaacaa tgtaccaag gcccgcgact gctgggccac ctcatccag ccttgggggt
661 ctctgctca cgtgacctgg atgacggcg gcatcttct ggcgccgtg gtcacttgg
721 gtacctgcta cggcttcac tgtacaaca tctggtgcaa cgtccgggg aagacggct
781 cgcgccagag caagggtgca gagcaagcgg gtgtggcct ccaaaagggg ttctgctcg
841 caccctgtgt cagcagcgtg aagtccatt cccgggcca gatccgcacg gtgaagatga
901 cttttgat cgtgacggct tacatgctct gctggcgcc ttcttcac atccagatg
961 ggtctgtct ggatcccatg tccgtctgga ccgaatcga aaacctacc atccatca
1021 ctgcttact gggctcctg aatagctgt gtaatccctg gatatacatg tttttagt
1081 gccatctct tcaagactgt gttcaagct tccatgctg ccaaaacatg aagaaaaat
1141 tcaacaaga agatactgac agtatgagca gaagacagac ttttattct aacaatgaa
1201 gcccaacaa cgtacgggt atgtggaagg actgcclaa atctccaag tccatcaant
1261 tcattcctgt tcaactga gccctgcatt catgcaac

//

LOCUS XXXXX 1450 bp mRNA PRI 12-OCT-1998
DEFINITION Homo sapiens breast cancer vasopressin receptor subtype 1b mRNA,
complete cds.

ACCESSION XXXXX

KEYWORDS

SOURCE human.

ORGANISM Homo sapiens
Eukaryota; Metazoa; Chordata; Vertebrata; Mammalia; Eutheria;
Primates; Catarrhini; Hominidae; Homo.

REFERENCE 1 (bases 1 to 1450)

AUTHORS North,W.G., Fay,M.J., Longo,K.A. and Du,J.
TITLE Expression of all known vasopressin receptor subtypes by small cell
tumors implies a multifaceted role for this neuropeptide

JOURNAL Cancer Research 58, 1866-1871 (1998)

REFERENCE 2 (bases 1 to 1450)

AUTHORS North,W.G. and Du,J.
TITLE Breast cancer cells express normal forms of all vasopressin
receptor subtypes plus an abnormal v2 receptor

JOURNAL Unpublished

REFERENCE 3 (bases 1 to 1450)

AUTHORS Du,J. and North,W.G.
TITLE Direct Submission
JOURNAL Submitted (12-OCT-1998) Physiology, Dartmouth Medical School, One
Medical Center Drive, Lebanon, NH 03756, USA

FEATURES Location/Qualifiers

source 1..1450
/organism="Homo sapiens"
/db_xref="taxon:9606"
/note="Breast cancer cell line MCF-7.;"
gene 1..1450
/gene="Breast cancer vasopressin subtype receptor 1b"
CDS 124..1398
/gene="Breast cancer vasopressin subtype receptor 1b"
/codon_start=1
/product="Breast cancer vasopressin receptor subtype 1b"
/translation="MDSGPLWDANPTPRGTL SAPNATTPWLGRDEELAKVEIGV LATV
LVLATGGNLAVLLTLGQLGRKRSRMHLFV LHLALTDLAV ALFQVLPQLLWDITYRFQG
PDLLCRAVKYLQVLSMFASTYMLLAMTLDRYLA VCHPLRSLQQPGQSTYLLIAAPWLL
AAIFSLPQVFIFSLREVIQSGVLD CWADFGFPWGP RAYLTWTTLAIFVLPVTMLTAC
YSLICHEICKNLKVKTQAWRVGGGGWRTWDRPSPSTLAATTRGLPSRVSSINTISRAK
IRTVKMTFVIVLAYIACWAPFFSVQMWSV WDKNAPDEDSTNV AFTISMLLGNLNSCCN
PWIYMGFNHLLPRPLRHLACCGGQPRMRRRLSDGSLSSRHTLLTRSSCPATLSLS
LSLTLSGRPRPEESPRDLELADGEGT AETIIF"

BASE COUNT 243 a 517 c 381 g 309 t

ORIGIN

1 tccctgcat tecaacgct tctcttct ctcacctcc cctgccact cattttatec
61 atcaaacctc tcaactgca tcaacacct ccttcaacc tccctcca gcaaacctg
121 ctcatggatt ctgggcctct gtgggatgcc aacccacc ctcggggcac cctctcgc
181 ccaatgccca caaacctct gctgggccgg gatgaggagc tggccaaggc ggagatcgga
241 gtctggcca ctgtcctgt gctggcgacc gggggcaacc tggtgtgt gctgacctg
301 ggccagctgg gcgcgaagcg ctcccgatg cacctgttcg tgetcaact agcctgaca
361 gacctggccg tggcctctt ccaggctgt ccacagctgc tgtggacat cacctaccg
421 ttcaggggcc ccgacctct gtgcagggcc gtaagtacc tgcaggtgt cagcatgtt
481 gcctcaact acatgctgt ggccatgacg ctggaccgct acctggctgt ctgcacccc
541 ctgcgcagcc tccagcagcc aggccagcc acctactgc tcatcgtgc tccctggtg
601 ctggccgcca tctcagcct cctcaagtc tcatcttt cctgcggga ggtgatccg
661 ggctcagggg tctggactg ctggcgagac ttcggctcc ctggggggcc acgggcctac
721 ctacctgga ccacctgac tatcttgt ctgccgtga ccatgctac ggcctgctac
781 agcctcatc gccatgat ctglaaaac ctaaaagta agacacagcc ctggcgggtg
841 ggaggagggg gctggaggac ttggacagc ccctcaact ccaactagc tgcaccact
901 cgggggctgc cctcgggt cagcagcacc aacacctct cacgggcca gatccgaaca
961 gtgaagatga ctttgtcat cgtgctggcc tacatcctt gctggctcc ctctcagt
1021 gtccagatgt ggtcctgtg ggacnagat gccctgatg aagattccac caatgtgct
1081 ttcacctct ctatctttt gggcaacctc aacagctgt gcaacctct gatctacatg
1141 ggctcaaca gccacctgtt accgcggccc ctgcgtcacc ttgctgctg tgggggtccc
1201 cagccagga tgcggcgcg gctctccgc ggcagcctct cgagcgcca caccagctg
1261 ctgacctgt ccagctccc ggccacctc agcctagcc ttagcctaac cctcagtgg
1321 aggccagc ctgaagagc accaaggac ttggagctgg cagatgggga agccaccgt
1381 gagaccatca tcttttaga aagactcgt ggggtctgt actgcccga ggactagtg
1441 aggttctctg

//

NCBI Entrez Nucleotide QUERY BLAST Entrez ? vasopressin North breast cancer Docs Per Page: Mod. Date limit:

Click here to enter the new
PubMed System

4 citations found for the articles selected (default all).

- AF101726
Homo sapiens vasopressin receptor subtype 1b mRNA, complete cds
gil4336681|gb|AF101726.1|AF101726 [4336681]
(View [GenBank report](#) , [FASTA report](#) , [ASN.1 report](#) , [Graphical view](#) , [1 MEDLINE link](#) ,
[1 protein link](#) , or [6 nucleotide neighbors](#))

- AF101725
Homo sapiens vasopressin receptor subtype 1a mRNA, complete cds
gil4336679|gb|AF101725.1|AF101725 [4336679]
(View [GenBank report](#) , [FASTA report](#) , [ASN.1 report](#) , [Graphical view](#) , [1 MEDLINE link](#) ,
[1 protein link](#) , or [19 nucleotide neighbors](#))

- AF101728
Homo sapiens truncated vasopressin receptor type 2 mRNA, complete cds
gil4323606|gb|AF101728.1|AF101728 [4323606]
(View [GenBank report](#) , [FASTA report](#) , [ASN.1 report](#) , [Graphical view](#) , [1 MEDLINE link](#) ,
[1 protein link](#) , or [8 nucleotide neighbors](#))

- AF101727
Homo sapiens vasopressin receptor type 2 mRNA, complete cds
gil4323604|gb|AF101727.1|AF101727 [4323604]
(View [GenBank report](#) , [FASTA report](#) , [ASN.1 report](#) , [Graphical view](#) , [1 MEDLINE link](#) ,
[1 protein link](#) , or [10 nucleotide neighbors](#))

Other Formats:

FASTA

Graphic

Links:

MEDLINE

Protein

Related Sequences

LOCUS AF101725 1298 bp mRNA PRI 04-MAR-1999
 DEFINITION Homo sapiens vasopressin receptor subtype 1a mRNA, complete cds.
 ACCESSION AF101725
 NID g4336679
 VERSION AF101725.1 GI:4336679
 KEYWORDS .
 SOURCE human.
 ORGANISM Homo sapiens
 Eukaryota; Metazoa; Chordata; Craniata; Vertebrata; Mammalia;
 Eutheria; Primates; Catarrhini; Hominidae; Homo.

REFERENCE 1 (bases 1 to 1298)
 AUTHORS North,W.G., Fay,M.J., Longo,K.A. and Du,J.
 TITLE Expression of all known vasopressin receptor subtypes by small cell
 tumors implies a multifaceted role for this neuropeptide
 JOURNAL Cancer Res. 58 (9), 1866-1871 (1998)
 MEDLINE 98240982

REFERENCE 2 (bases 1 to 1298)
 AUTHORS North,W.G. and Du,J.
 TITLE Breast cancer cells express normal forms of all vasopressin
 receptor subtypes plus an abnormal v2 receptor
 JOURNAL Unpublished

REFERENCE 3 (bases 1 to 1298)
 AUTHORS Du,J. and North,W.G.
 TITLE Direct Submission
 JOURNAL Submitted (26-OCT-1998) Physiology, Dartmouth Medical School, 1
 Medical Center Drive, Lebanon, NH 03756, USA

FEATURES Location/Qualifiers
 source 1..1298
 /organism="Homo sapiens"
 /db_xref="taxon:9606"
 /cell_line="MCF-7"
 /cell_type="breast cancer"

CDS 24..1280
 /codon_start=1
 /product="vasopressin receptor subtype 1a"
 /protein_id="AAD17891.1"
 /db_xref="PID:g4336680"
 /db_xref="GI:4336680"
 /translation="MRLSAGPDAGPSGNSSPWVPLATGAGNTSREAEALGEGNGPPRD
 VRNEELAKLEIAVLAVTFFAVAVLGNSSVLLALHRTPRKTSRMHLFIRHLSLADLAVAF
 FQVLPQMCWDITYRFRGPDWLCRVVKHLQVFGMFASAYMLVVM TADRYIAVCHPLKTL
 QQPARRSRLMIAAAWVLSFVLSTPQYFVFSMIEVNNVTKARDCWATFIQPWGSRAYVT
 WMTGGIFVAPVVILGTCYGFICYNIWCNVRGKTASRQSKGAEQAGVAFQKGFLLAPCV
 SSVKSISRKIRTVMFTFVIVTAYIVCWAPFFIIQMWSVWDPMSVWTESENPTITITA
 LLGSLNCCNPWIYMFVSGHLLQDCVQSFPCCQNMKEKFNKEDTDSMSRRQTFYSNRR
 SPTNSTGMWKDSPKSSKSIKFI PVST"

BASE COUNT 258 a 399 c 364 g 277 t

ORIGIN

1 cgagtaggag ctgcatggac agcatgcgtc tctccgccgg tcccgacgcg gggccctcgg
61 gcaactccag cccatggtag cctctggcca cggcgctgg caacacaagc cgggaggccg
121 aagccctcgg ggagggcaac ggcccaccga gggacgtgcg caacgaggag ctggccaaac
181 tggagatcgc cgtgctggcg gtgacttctg cggtgccgt gctgggcaac agcagcgtac
241 tgctggctct gcaccggacg ccgcaaga cgtcccgcac gcaccttc atccgacacc
301 tcagcctggc cgacctggcc gtggcattct tccaggtgct gccgcaaag tgctgggaca
361 tcacctaccg ctcccgccg cccgactggc tggccgctg ggtgaagcac ctgcaggtgt
421 toggcatgt tgctggcc tacatgctgg tagcatgac agccgaccgc tacatcgcg
481 tgtgccacc gctcaagact ctgcaacagc ccgcaaga ctcgcaagc atgatcgcg
541 ccgctgggt gctgagctt gtgctgagca cgcgcagta ctctcttc tccatgatc
601 aggtgaacaa tgcaccaag gcccgact gctggccac ctcatccag cctggggt
661 ctctgccta cgtgacctg atgacggcg gcatttgt ggcgccgtg gcatcttg
721 gtacctgta cggctcctc tctacaaca tctggtgca cgtccgccc aagacggct
781 cgcgccagag caaggtgca gagcaagcg gttggcctt caaaagggg ttctgctc
841 caccctgtg cagcagcgt agtccattt cccggcca gatccgacg gtgaagatga
901 ctttgtgat cgtgacggc tacatgctt gctggcgcc tttctcctc atccagatg
961 ggtctgtc ggatccatg tccgtctgga ccgaatcga aaacctacc atccatca
1021 ctgcattact ggttccctg aatagctgt gtaatccctg gatatacatg tttttagtg
1081 gccatctct tcaagactg gtcaaagct tccatgctg caaaacatg aaggaaaaat
1141 tcaacaaaga agatactgac agtatgagca gaagacagac ttttattct aacaatcga
1201 gcccaacaaa cagtacggg atgtggaagg actgcctaa atctccaag tccatcaat
1261 tcattcctg tcaactga gcctgcatt catgcaac

//

the above report in format

Other Formats: FASTA Graphic

Links: MEDLINE Protein Related Sequences

LOCUS AF101726 1450 bp mRNA PRI 04-MAR-1999
DEFINITION Homo sapiens vasopressin receptor subtype 1b mRNA, complete cds.

ACCESSION AF101726

NID g4336681

VERSION AF101726.1 GI:4336681

KEYWORDS .

SOURCE human.

ORGANISM Homo sapiens
Eukaryota; Metazoa; Chordata; Craniata; Vertebrata; Mammalia;
Eutheria; Primates; Catarrhini; Hominidae; Homo.

REFERENCE 1 (bases 1 to 1450)

AUTHORS North,W.G., Fay,M.J., Longo,K.A. and Du,J.

TITLE Expression of all known vasopressin receptor subtypes by small cell
tumors implies a multifaceted role for this neuropeptide

JOURNAL Cancer Res. 58 (9), 1866-1871 (1998)

MEDLINE 98240982

REFERENCE 2 (bases 1 to 1450)

AUTHORS North,W.G. and Du,J.

TITLE Breast cancer cells express normal forms of all vasopressin
receptor subtypes plus an abnormal v2 receptor

JOURNAL Unpublished

REFERENCE 3 (bases 1 to 1450)

AUTHORS Du,J. and North,W.G.

TITLE Direct Submission

JOURNAL Submitted (26-OCT-1998) Physiology, Dartmouth Medical School, 1
Medical Center Drive, Lebanon, NH 03756, USA

FEATURES Location/Qualifiers

source 1..1450
/organism="Homo sapiens"
/db_xref="taxon:9606"
/cell_line="MCF-7"
/cell_type="breast cancer"

CDS 124..1398
/codon_start=1
/product="vasopressin receptor subtype 1b"
/protein_id="AAD17892.1"
/db_xref="PID:g4336682"
/db_xref="GI:4336682"

/translation="MDSGPLWDANPTPRGTL SAPNATTPWLGRDEELAKVEIGVLATV
LVLATGGNLAVLLTLGQLGRKRSRMLHLFVHLALTDLAVALFQVLPQLLWDITYRFQG
PDLLCRAVKYLQVLSMFASTYMLLAMTLDRYLAVCHPLRSLQQPGQSTYLLIAAPWLL
AAIFSLPQVFIFSLREVIQSGVLDWCWADFGFPWGPWAYLTWTTLAIFVLPVTMLTAC
YSLICHEICKNLKVKTAQAWRVGGGGWRTWDRPSPSTLAATTRGLPSRVSSINTISRAK
IRTVKMTFVIVLAYIACWAPFFSVQMWSVWDKNAPDEDSTNVAFTISM L L GNLN S C C N
PWIYMGFNHLLPRPLRHLACCGPQPRMRRRLSDGSLSSRHTLLTRSSCPATLSLS
LSLTLGRRPRPEESPRDLELADGEGTAETIIF"

BASE COUNT 243 a 517 c 381 g 309 t

ORIGIN

1 tcctgtcat tctcaacgt tctcctttc ctccacctcc cctgccactc cattttatcc
61 atcaaacctc tccacttga tccacacct ccttcatcc ttcctcca gcaaaccctg
121 tcatggatt ctggcctct gtgggatgcc aacccaccc ctggggcac ctctctgcc
181 cccaatgcca caacaccctg gctgggccgg gatgaggagc tggccaaggt ggagatcgga
241 gtcctggcca ctgtcctggg gctggcgacc gggggcaacc tggctgtgct gctgaccctg
301 ggccagctgg gccgcaagcg ctcccgatg cacctgttg tgctgcactt agccctgaca
361 gacctggccg tggcgctctt ccaggtgctg ccacagctgc tgtgggacat cacctaccgc
421 ttccagggcc ccgacctct gtgcagggcc gtcaagtacc tgcaggtgct cagcatgtt
481 gctccacct acatgtctct ggccatgacg ctggaccgct acctggctgt ctgcacccc
541 ctgcgcagcc tccagcagcc aggccagtcc acctacctgc tcatcgtctg tcctggctg
601 ctggccgcca tctcagcct cctcaagtc ttcattttt cctgcggga ggtgatccag
661 ggctcagggg tgctggactg ctgggcagac ttcggcttc ctggggggcc acgggcctac
721 ctacctgga ccacctggc tctctcgtt ctgccggtga ccctgctcac ggctgctac
781 agcctcatct gccatgagat ctgtaaaac ctaaaagtca agacacaggc ctggcgggtg
841 ggaggagggg gctggaggac ttggacagg cctcacctt ccaccttagc tgcaccact
901 cgggggctgc catctcgggt cagcagcatc aacacctct cacgggcaa gatccgaaca
961 gtgaagatga cctttgtcat ctgtctggcc tacatcgtt gctgggctcc ctctttagt
1021 gtccagatgt ggtccgtgtg ggacaagaat gccctgatg aagattccac caatgtggg
1081 ttaccatct ctatgtttt gggcaacctc aacagctgct gcaaccctg gatctacatg
1141 ggctcaaca gccacctgtt accgcggccc ctgcctcacc ttgctgctg tgggggtccc
1201 cagcccagga tgcgccggcg gctctccgac ggcagcctct cgagccgcca caccagctg
1261 ctgaccogct ccagctgccc ggccacctc agcctcagcc tcagcctaac cctcagtggt
1321 aggccagggc ctgaagagtc accaaggac ttggagctgg cagatgggga aggcaccgct
1381 gagaccatca tcttttagga aagactcgt ggggtctggt actgccccca ggactagtgg
1441 aggttctctg

//

the above report in format

Other Formats: [FASTA](#) [Graphic](#)Links: [MEDLINE](#) [Protein](#) [Related Sequences](#)

LOCUS AF101728 1307 bp mRNA PRI 03-MAR-1999
 DEFINITION Homo sapiens truncated vasopressin receptor type 2 mRNA, complete cds.

ACCESSION AF101728

NID g4323606

VERSION AF101728.1 GI:4323606

KEYWORDS .

SOURCE human.

ORGANISM Homo sapiens

Eukaryota; Metazoa; Chordata; Craniata; Vertebrata; Mammalia;
 Eutheria; Primates; Catarrhini; Hominidae; Homo.

REFERENCE 1 (bases 1 to 1307)

AUTHORS North,W.G., Fay,M.J., Longo,K.A. and Du,J.

TITLE Expression of all known vasopressin receptor subtypes by small cell tumors implies a multifaceted role for this neuropeptide

JOURNAL Cancer Res. 58 (9), 1866-1871 (1998)

MEDLINE 98240982

REFERENCE 2 (bases 1 to 1307)

AUTHORS North,W.G. and Du,J.

TITLE Breast cancer cells express normal forms of all vasopressin receptor subtypes plus an abnormal v2 receptor

JOURNAL Unpublished

REFERENCE 3 (bases 1 to 1307)

AUTHORS Du,J. and North,W.G.

TITLE Direct Submission

JOURNAL Submitted (26-OCT-1998) Physiology, Dartmouth Medical School, One Medical Center Drive, Lebanon, NH 03756, USA

FEATURES Location/Qualifiers

source 1..1307

/organism="Homo sapiens"

/db_xref="taxon:9606"

/cell_line="MCF-7"

/tissue_type="breast cancer"

CDS

33..962

/note="alternatively spliced"

/codon_start=1

/product="truncated vasopressin receptor type 2"

/protein_id="AAD16445.1"

/db_xref="PID:g4323607"

/db_xref="GI:4323607"

/translation="MLMASTTSAVPGHPSLPSLPSNSSQERPLDTRDP LLARAELALL
 SIVFVAVALSNGLVLAALARRGRRGHWAPIHVFIGHLCLADLAVALFQVLPQLAWKAT
 DRFRGPDALCRAVKYLQMGMYASSYMILAMTLDRHRAICRPM LAYRHGSGAHWNRPV
 LVAWAFSLLLSLPQLFIFAQRNVEGGSGVTDWCACFAEPWGRRTYVTWIALMVFAPT
 LGIAACQVLIFREIHASLVPGPSE RPPGRRRRGRRTGSPGEGAHVSAAVAKTVRMTLVI
 VVVYVLCWAPFFLVQLWAAWDPEAPLEGGCSRG"

BASE COUNT 191 a 447 c 405 g 264 t

ORIGIN

1 caggccctca gaacacctgc cccagcccca ccatgctcat ggcgtocacc acttccgctg
61 tgcctgggca tccctctctg cccagcctgc ccagcaacag cagccaggag aggccactgg
121 acaccggga cccgctgcta gcccgggagg agctggcgct gctctcata gtctttgtgg
181 ctgtggccct gagcaatggc ctggctgctg cggccctagc tcggcggggc cggcggggcc
241 actgggcacc catacacgtc tcattggcc acttgtgctt ggccgacctg gccgtggctc
301 tgttccaagt gctgccccag ctggcctgga aggccaccga ccgcttccgt gggccagatg
361 ccctgtgtcg ggccgtgaag tatctgcaga tggggggcat gtatgcctcc tctacatga
421 tctggccat gacgctggac cgccaccgtg ccatctgccg tcccatgctg gcgtaccgcc
481 atggaagtgg ggctcactgg aaccggccgg tgctagtggc ttgggccttc tcgctcctc
541 tcagcctgcc ccagctcttc atcttcgcc agcgaacgt ggaaggtggc agcggggta
601 ctgactgctg ggctgcttt ggggagcctt ggggcccgtc cacctatgtc acctggattg
661 ccctgatggt gttcgtggca cctaccctgg gtatcggccg ctgccaggtg ctatcttcc
721 gggagattca tgccagtctg gtgccagggc catcagagag gcctgggggg cggcaggg
781 gacgccggac aggcagcccc ggtgaggag cccacgtgtc agcagctgtg gccaagactg
841 tgaggatgac gctagtatt gtggtcgtct atgtgctgtg ctgggcacc tcttctctg
901 tgcagctgtg ggccgctgg gaccggagg cacctctgga aggtgggtgt agccgtggct
961 agggctgacg gggccacttg ggctggccg catgccctg tgccccacca gccatctga
1021 acccaacctg gatcctccac cccacaggg gcgcccttg tgctactcat gttgctggcc
1081 agcctcaaca gctgcaccaa cccctggatc tatgcatctt tcagcagcag cgtgtctca
1141 gagctcgaa gcttgcctg ctgtgcccg ggacgcacc caccagcct gggccccaa
1201 gatgagtctt gcaccaccg cagctctcc ctggccaagg acactcatc gtgaggagct
1261 gttgggtgtc ttgcctctag aggccttgag aagctcagct gccttc

//

the above report in format

Other Formats: [FASTA](#) [Graphic](#)

Links: [MEDLINE](#) [Protein](#) [Related Sequences](#)

LOCUS AF101727 1201 bp mRNA PRI 03-MAR-1999
 DEFINITION Homo sapiens vasopressin receptor type 2 mRNA, complete cds.

ACCESSION AF101727

NID g4323604

VERSION AF101727.1 GI:4323604

KEYWORDS .

SOURCE human.

ORGANISM Homo sapiens

Eukaryota; Metazoa; Chordata; Craniata; Vertebrata; Mammalia;
 Eutheria; Primates; Catarrhini; Hominidae; Homo.

REFERENCE 1 (bases 1 to 1201)

AUTHORS North,W.G., Fay,M.J., Longo,K.A. and Du,J.

TITLE Expression of all known vasopressin receptor subtypes by small cell
 tumors implies a multifaceted role for this neuropeptide

JOURNAL Cancer Res. 58 (9), 1866-1871 (1998)

MEDLINE 98240982

REFERENCE 2 (bases 1 to 1201)

AUTHORS North,W.G. and Du,J.

TITLE Breast cancer cells express normal forms of all vasopressin
 receptor subtypes plus an abnormal v2 receptor

JOURNAL Unpublished

REFERENCE 3 (bases 1 to 1201)

AUTHORS Du,J. and North,W.G.

TITLE Direct Submission

JOURNAL Submitted (26-OCT-1998) Physiology, Dartmouth Medical School, One
 Medical Center Drive, Lebanon, NH 03756, USA

FEATURES Location/Qualifiers

source 1..1201

/organism="Homo sapiens"

/db_xref="taxon:9606"

/cell_line="MCF-7"

/tissue_type="breast cancer"

CDS 33..1148

/codon_start=1

/product="vasopressin receptor type 2"

/protein_id="AAD16444.1"

/db_xref="PID:g4323605"

/db_xref="GI:4323605"

/translation="MLMASTTSAVPGHPSLPSLPSNSSQERPLDTRDPLLARAELALL
 SIVFVAVALSNGLVLAALARRGRRGHWAIPHVFIGHLCLADLAVALFQVLPQLAWKAT
 DRFRGPDALCRAVKYLQMVGMYASSYMILAMTLDRHRAICRPMLAYRHGSGAHWNRPV
 LVAWAFSLLSLPQLFIFAQRNVEGGSGVTDCWACFAEPWGRRTYVTWIALCMVFVAPT
 LGIAACQVLIFREIHASLVPGPSEPPGRRRRGRRTGSPGEGAHVSAAVAKTVRMTLVI
 VVVYVLCWAPFFLVQLWAAWDPEAPLEGAPFVLLMLLASLNSCTNPWIYASFSSSVSS
 ELRSLCCARGRTPPSLGPDQDESCTTASSSLAKDTSS"

BASE COUNT 174 a 407 c 375 g 245 t

ORIGIN

1 caggccctca gaacacctgc cccagcccca ccatgctcat ggctccacc acttccgctg
61 tgctgggca tccctctctg cccagcctgc ccagcaacag cagccaggag aggccactgg
121 acaccggga cccgctgcta gcccgggagg agctggcgt gctctccata gtctttgtg
181 ctgtggcct gagcaatggc ctggctggg cggccctagc tggcggggc cggcggggc
241 actgggacc catacacgtc ttattggcc acttgtcct ggccgacctg gccgtggctc
301 tgtccaagt gctgccccag ctggcctgga aggccaccga ccgctccgt gggccagatg
361 ccctgtgtc ggccgtgaag tatctgcaga tgggggcat gtatgcctcc tctacatga
421 tctggccat gacgtggac cgccaccgtg ccatctgcc tccatgctg gctaccgcc
481 atggaagtgg ggctcactgg aaccggcgg tgctagtggc ttggccttc tctctctc
541 tcagcctgc ccagctctc atctctgcc agcgaacgt ggaagggtgg agcggggtca
601 ctgactgctg ggctgctt gggagccct ggggctgc cacctatgc acctggattg
661 ccctgatgtt gttctggca cctaccctgg gtatgccgc ctgccagggt ctatcttc
721 gggagattca tgccagtctg gtccagggc catcagagag gcctggggg cggcgaggg
781 gacggggac aggcagccc ggtgaggag cccacgtgc agcagctgtg gccaagactg
841 tgaggatgac gctagtatt gtgtctct atgtctgtg ctggcacc ttctcttg
901 tgcagctgtg ggccgctgg gaccggagg cacctctga agggcgccc ttgtgctac
961 tcatgttct ggccagctc aacagctga ccaaccctg gatctatga tcttcagca
1021 gcagcgtgc ctacagctg cgaagctgc tctctgtgc cggggacgc acccaccga
1081 gcctgggtc ccaagatgag tctgcacca ccgagctc ctccctggc aaggacactt
1141 catcgtgagg agctgtggg tctctcct ctgaggctt tgagaagctc agctgcctc
1201 c

//

the above report in format

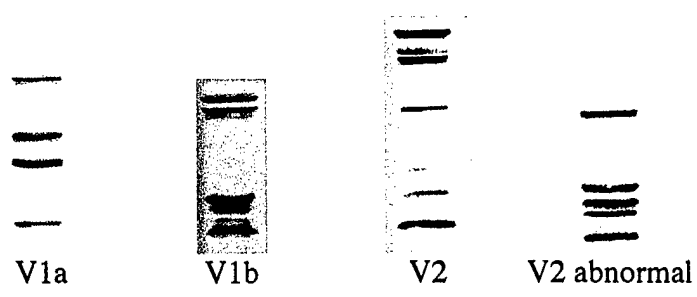

Western Analysis of Vasopressin Receptors in MCF-7 Breast Cancer Cells