

738.06

NASA SP-5051



TECHNOLOGY UTILIZATION

THE METALLURGY, BEHAVIOR, AND APPLICATION OF THE 18-PERCENT NICKEL MARAGING STEELS

A SURVEY

AMPTIAC

Reproduced From
Best Available Copy



MISSENT TO NORTH AMERICAN ROCKWELL CORPORATION

NORTH AMERICAN ROCKWELL
COLUMBIA
JAN 20 1968
RECEIVED
ENGINEERING DATA SERVICES

NATIONAL AERONAUTICS AND SPACE ADMINISTRATION

DISTRIBUTION STATEMENT A
Approved for Public Release
Distribution Unlimited

20000828 057

NASA SP-5051

THE METALLURGY, BEHAVIOR, AND APPLICATION OF THE 18-PERCENT NICKEL MARAGING STEELS

A SURVEY

By A. M. Hall
and C. J. Slunder

Prepared under contract for NASA by
Battelle Memorial Institute,
Columbus Laboratories



Technology Utilization Division
OFFICE OF TECHNOLOGY UTILIZATION
NATIONAL AERONAUTICS AND SPACE ADMINISTRATION
1968
Washington, D.C.

NOTICE • This document was prepared under the sponsorship of the National Aeronautics and Space Administration. Neither the United States Government nor any person acting on behalf of the United States Government assumes any liability resulting from the use of the information contained in this document, or warrants that such use will be free from privately owned rights.

For sale by the Superintendent of Documents,
U.S. Government Printing Office, Washington, D. C. 20402
Price \$1.50
Library of Congress Catalog Card Number 68-61419

Foreword

This report resulted from a survey of users and manufacturers of maraging steels, Government agencies, research institutions, and published literature. It presents the technical status of the 18-percent nickel maraging steels in detail and brings together a large body of knowledge with regard to the metallurgical and engineering aspects of maraging steels.

Since such steels were first announced in 1959, they have become highly important in aerospace, defense, and industrial work. The requirements of the National Aeronautics and Space Administration have given impetus to their development, and research now underway is expected to result in further improvements and applicability.

The NASA Office of Technology Utilization sponsored this report as part of its program to disseminate information on technological developments which appear to be useful for general industrial applications.

Acknowledgments

Special thanks are due to James E. Campbell who, because of the death of C. J. Slunder, was called on to contribute the chapter on mechanical and physical properties of maraging steels. The assistance offered by Howard R. Batchelder and Vernon W. Ellzey of Battelle's Columbus Laboratories also was much appreciated.

H. J. WAGNER
Chief, Specialty Alloys Division
Battelle Memorial Institute
Columbus Laboratories

CONTENTS

	Page
CHAPTER 1. INTRODUCTION	1
CHAPTER 2. ^A APPLICATIONS AND USES OF THE 18-PERCENT NICKEL MARAGING STEELS	5
Applications in Aerospace	5
Applications in Hydrospace	11
Tooling Applications	13
Structural Applications	17
CHAPTER 3. ^{Feb} PHYSICAL METALLURGY	23
Age-Hardenable Martensitic Steels	23
The Iron-Nickel System	25
The Martensite in Maraging Steels	27
Aging Reactions	28
Reversion to Austenite	33
^{Feb} Thermal Treatment of Maraging Steels	36
Influence of Cold Work ^{Feb}	36
Banding and Nonmetallic Inclusions	38
CHAPTER 4. MANUFACTURE OF MILL PRODUCTS	43
Melting	43
^{Feb} Ingot Breakdown	45
Conversion of Slabs, Blooms, and Billets	46
Annealing	47
Quality Control	47
CHAPTER 5. FABRICATION	49
Cutting, ^{Feb} Shearing, ^{Feb} and ^{Feb} Grinding	49
^{Feb} Hot Working	50
^{Feb} Cold Forming	53
^{Feb} Warm Working	59
^{Feb} Machining	60
^{Feb} Welding	69
Heat Treating	83
Descaling and Pickling	87
CHAPTER 6. ^{Feb} MECHANICAL AND PHYSICAL PROPERTIES OF 18-PERCENT NICKEL MARAGING STEELS	89
Specifications for Composition and Properties	89
Properties of Solution-Annealed Maraging Steels	90
Effects of Variations in Solution-Annealing and Aging Temperatures on the Properties	90
^{Feb} Tensile Properties at Room Temperature	93
Tensile Properties at Elevated Temperatures	93
Tensile Properties at Low Temperatures	95
^{Feb} Compressive Properties at Elevated Temperatures	95
^{Feb} Dynamic Modulus of Elasticity of Maraging Steels	95
^{Feb} Creep Properties	99
^{Feb} Fatigue Properties	100
^{Feb} Charpy V-Notch Impact Properties	102
^{Feb} Fracture Toughness	102
^{Feb} Shear Strength and Bearing Strength ^{Feb}	107
Physical Properties	108
CHAPTER 7. ^{Feb} CORROSION, STRESS CORROSION, ^{Feb} AND RELATED PROPERTIES	109
General Corrosion ^{Feb}	109
Stress-Corrosion Cracking and Hydrogen-Stress Cracking	110
CHAPTER 8. FUTURE PROSPECTS	127
REFERENCES	129
BIBLIOGRAPHY	137

v

CHAPTER 1

Introduction

The maraging steels evoked tremendous interest, especially in the aerospace world, when their development was announced in 1959. These extra-low-carbon, high-nickel, iron-base alloys held great promise of providing an extraordinary combination of structural strength and fracture toughness in a material that was, at the same time, readily weldable and easy to heat-treat. The alloys were termed "maraging" because they possess a martensitic microstructure when annealed, and attain their ultrahigh strength on being aged in the annealed or martensitic condition. Yield strengths up to and well beyond 300 ksi are available in these steels in the aged condition.

It was quickly recognized that the maraging steels might be especially well qualified for a host of ultra-high-strength precision parts for numerous applications. The National Aeronautics and Space Administration's need for boosters possessing enormous thrust provided the sustaining motivation for rapid development of these steels.

The original announcement of the development of maraging steel encompassed a 25 percent nickel steel and a 20 percent nickel steel, both of which contained significant amounts of titanium, aluminum, and columbium, as well as two 18 percent nickel steels containing appreciable amounts of cobalt, molybdenum, and titanium. Their compositions are given in table 1 (refs. 1-7).

Studies of engineering properties, fabrication techniques, and heat-treating procedures have shown that the two 18 percent nickel steels have advantages in toughness

and simplicity of heat treatment over the other two alloys. As a consequence, the former have achieved engineering importance, while the latter have faded from the scene. Because one of the 18 percent nickel steels develops a yield strength of about 250 ksi and the other a yield strength of some 280 to 300 ksi when aged, they are often referred to as the 18 Ni 250 grade and the 18 Ni 280 grade or 18 Ni 300 grade, respectively.

Considerable effort has been directed at the development of additional maraging steels. Modifications suitable for use in the form of castings and for service at moderately elevated temperatures have been investigated. In addition, two steels having especially high degrees of toughness, with yield strengths in the range of 180 to 210 ksi, have been developed. One is an 18 percent nickel alloy of the same type as the 18 Ni 250 grade and 18 Ni 280 grade; this steel is known as the 18 Ni 200 grade. The other steel is a 12 percent nickel alloy to which chromium, molybdenum, titanium, and aluminum have been added. Another variant of the 18 percent nickel type has been developed and is capable of attaining exceptionally high yield strengths in the vicinity of 350 ksi. Not unexpectedly, this steel is referred to as the 18 Ni 350 grade. The compositions of all these steels appear in table 1. Some effort has also been directed toward developing maraging steels in which manganese is substituted for some of the nickel (ref. 8).

TABLE 1.—Compositions of Maraging Steels

Designation	Composition, percent											References
	C ^a	Mn ^a	Si ^a	S ^a	P ^a	Ni	Co	Mo	Ti	Al	Cb	
25 Ni -----	0.03	0.10	0.10	0.01	0.01	25.0-26.0			1.3-1.6	0.15-0.30	0.30-0.50	1, 2
20 Ni -----	.03	.10	.10	.01	.01	19.0-20.0			1.3-1.6	0.15-0.30	0.30-0.50	1
18 Ni 280 grade --	.03	.10	.10	.01	.01	18.0-19.0	8.5-9.5	4.6-5.2	0.5-0.8	0.05-0.15	-	1
18 Ni 250 grade --	.03	.10	.10	.01	.01	17.0-19.0	7.0-8.5	4.6-5.2	0.3-0.5	0.05-0.15	-	1
18 Ni 200 grade --	.03	.10	.10	.01	.01	17.0-19.0	8.0-9.0	3.0-3.5	0.15-0.25	0.05-0.15	-	3
12 Ni ^b -----	.03	.10	.12	.01	.01	11.5-12.5	-	2.75-3.25	0.10-0.35	0.20-0.50	-	4
Cast -----	.03	.10	.01	.01	.01	16.0-17.5	9.5-11.0	4.4-4.8	0.15-0.45	0.05-0.15	-	5
15 Ni ^c -----	.03					15	7	4.5	0.7	0.5	-	6
18 Ni 350 grade --	.01	.10	.10	.005	.005	17-18	12-13	3.5-4.0	1.6-2.0	0.1-0.2	-	7

^a Maximum.

^b Also contains 4.75-5.25 percent Cr.

^c Nominal composition.

Attention is now focused largely on the various grades of the 18 percent nickel alloys containing cobalt, molybdenum, and titanium. The research-and development effort that has been devoted to the production, mechanical and physical properties, corrosion behavior, physical metallurgy, as well as to the forming, joining, and heat treating of these steels, has been quite substantial. Much has been learned of their metallurgy; patterns of usage have evolved; methods of producing a broad range of mill products have been established; and the means for successfully forming, joining, and heat treating these metals have been developed.

Inevitably, as has been the case with most other structural materials, problems have arisen with the use of these steels. While researchers were seeking improved understanding of the maraging type of alloy, these problems were being tackled vigorously and often with an encouraging degree of success.

The maraging steels have been investigated by a number of steel producers, aerospace hardware and missile manufacturers, numerous Government laboratories, and universities and independent contract research facilities in the United States and abroad. Members of NASA's Lewis Research Center have studied the mechanical properties of the maraging steels, investigated the failure of maraging steel components under test, and contributed to an improved understanding of the fracture toughness of these materials. The result of all these various activities is that a considerable body of literature concerning maraging steels has been generated.

This report will present a comprehensive view of the present technical status of the maraging steels and the outlook for the future of these materials, as indicated by the data that have become available. Specifically, the purpose is to provide the research worker, the materials engineer, the process engineer, the designer, and other interested readers with a report on the maraging steels that can be used to—

(1) Assist in the selection of these steels for appropriate applications.

(2) Serve as a point of departure for further study and evaluation of the maraging steels.

(3) Function as a guide or first approximation in establishing fabrication procedures for the steels.

(4) Assist in identifying potential trouble spots and corresponding precautionary procedures in fabricating and using the steels.

(5) Serve as a text or reference work.

Most of the material in the report relates to the 18 percent nickel variety of maraging steel containing additions of cobalt, molybdenum, and titanium. This type of maraging steel has achieved current practical significance, and the present knowledge of its metallurgical and mechanical characteristics is more advanced than that of the other types. However, other types of maraging steel will be mentioned at appropriate places to illustrate technical points or to indicate trends that may influence the future prospects and opportunities for the maraging steels.

CHAPTER 2

Applications and Uses of the 18-Percent Nickel Maraging Steels

APPLICATIONS IN AEROSPACE

Large Rocket-Motor Cases

There is no doubt that the large, solid-propellant, rocket-motor program sparked the considerable research and development that has been conducted to take advantage of the many fine properties of the maraging steels. These steels, which combine a high strength-to-weight ratio with good fracture toughness, ready weldability, and simple heat treatment, became available just when such properties were needed to permit a scaleup in missile-case dimensions.

The joint Air Force-NASA 260-inch-diameter booster program was started in 1962. An early report (ref. 9) discussed the reasons for the selection of maraging steel as the material from which the motor cases were to be constructed. In addition to the good combination of mechanical properties, it was pointed out that the maraging steels are readily machined, formed, and welded. Preweld and postweld treatments are not required, and full strength is obtained by aging at 900° F and air cooling. By contrast, conventional quench and temper heat treatments, such as are used for most other high-strength alloys, introduce problems in handling and in size of equipment necessary to process the very large motor cases.

The original work statement provided that state-of-the-art technology be used wherever possible (ref. 10). While events have generally proved that conventional melting, processing, and fabricating tech-

niques may be used with the maraging steels, a number of technological advances had to be made to meet the reliability and tolerance requirements of the program. This necessitated extensive metallurgical investigations dealing with various aspects of evaluation and characterization of the maraging steels. Welding and fabricating procedures, and especially testing and inspection techniques, required further study in the light of specific requirements relating to rocket-motor cases. Finally, fabrication, burst testing, and static firing of smaller motor cases were undertaken to provide the data and experience needed to carry on the 260-inch booster program. Many groups of investigators participated in these studies. Their work has been recorded in numerous reports and other published matter. This intensive effort has resulted in a continuing advance in the state of the art and knowledge of the maraging steels.

The goal of the 260-inch-diameter booster program was achieved by the successful static test firing of two short-length motors in late 1965 and early 1966. This was a major milestone in the development of solid-propellant rocketry (ref. 10). Previous experience with 120-inch and 156-inch-diameter cases, as well as detailed studies of the many factors involved in fabrication and testing, contributed to the success of the program. Some of the program problems and their solutions are summarized in reference 10. It would be of use to review the highlights of that report in order to focus on the pertinent factors that determine

the usefulness of the maraging steels. Garland's excellent summary (ref. 11) includes many practical aspects of the undertaking.

The combination of high strength and good fracture toughness is a prime requisite for applications where performance is dependent on resistance to brittle fracture at stresses below the design stress. This means that the alloy should tolerate cracks or flaws at least as large as the largest flaw that may escape detection by inspection techniques. Obviously, it is impossible to fabricate something as large as a 260-inch-diameter-by-60-foot-long rocket-motor case without some flaws such as nicks, dents,

and inclusions being present within the metal or on the metal surface. Unfortunately, the size of tolerable flaws in high-strength alloys under plane-strain conditions decreases as the strength of the alloy increases. Hence, it is sometimes necessary to compromise between strength and toughness requirements. This was done in the selection of consumable-electrode, vacuum-arc-remelted (VAR), 18 percent nickel 200-grade maraging steel for the Aerojet 260-inch cases, because subscale 36-inch-diameter cases made of 250-grade maraging steel had failed in a brittle manner well below the predicted burst pressure.

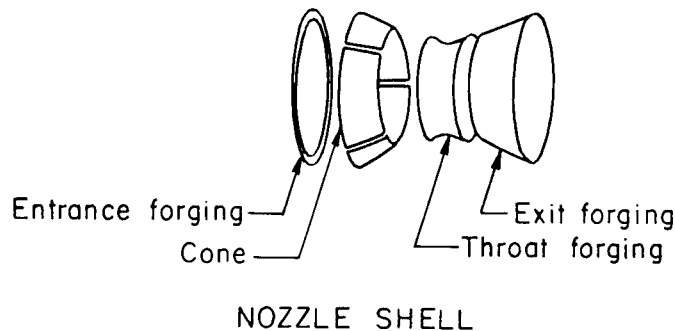
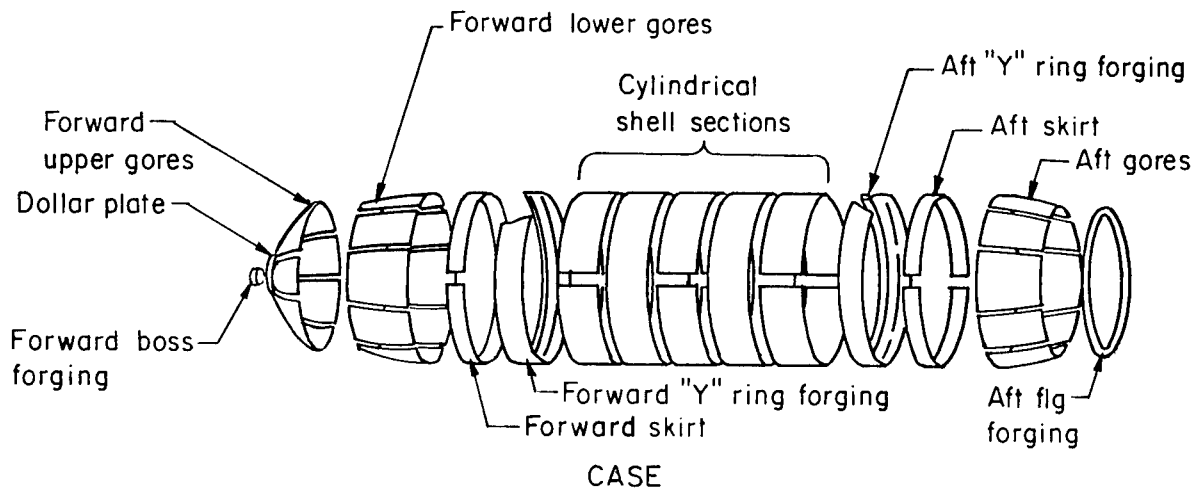

FIGURE 1.—260-inch, short-length case and nozzle shell components.

Figure 1 (ref. 11) illustrates the configuration of the components that make up a 260-inch short-length case and nozzle shell assembly. The components, made from plate material, were formed in the annealed condition using conventional pressure vessel cold-forming equipment. Forgings were used when precise dimensional control was required, when difficult forming operations arose, and when preclusion of longitudinal welding of thick sections was desired (ref. 10). An example of such forgings is the large Y-rings used for transition between the heads and the cylindrical section; one of these is shown in figure 2. These were made from 26 000-pound billets and were the largest ring-rolled forgings ever made from maraging steel. As shown in figure 1, large forgings also were used to fabricate the nozzle shell.

Joining and assembly of the components was done by welding. The cylindrical section was made by rolling 102-inch-wide plates into semicircles and joining two of these by longitudinal welds. Five of these cylinders were then joined by circumferential welds to form the cylindrical sections. The other components were also welded as necessary to form the complete case. It is clear that welding is a key process in the fabrication of rocket cases. The gas tungsten-arc (GTA) method of welding had been used earlier in the fabrication of 120-inch- and 156-inch-diameter cases and proved satisfactory. The automatic GTA process was also selected for the 260-inch-diameter cases because sound welds could be made with minimum contamination (ref. 11). However, a great deal of work was done to determine the best filler metal composition (ref. 12) and fracture toughness, as well as other properties of the welds (refs. 13, 14, and 15). The three programs were all in support of the NASA 260-inch-case contracts. Welds made with the selected filler metal had a yield strength of about 200 to 215 ksi after aging. It was also found that the weld metal responded to aging in the same way as the parent metal. This made it possible to fabricate the case

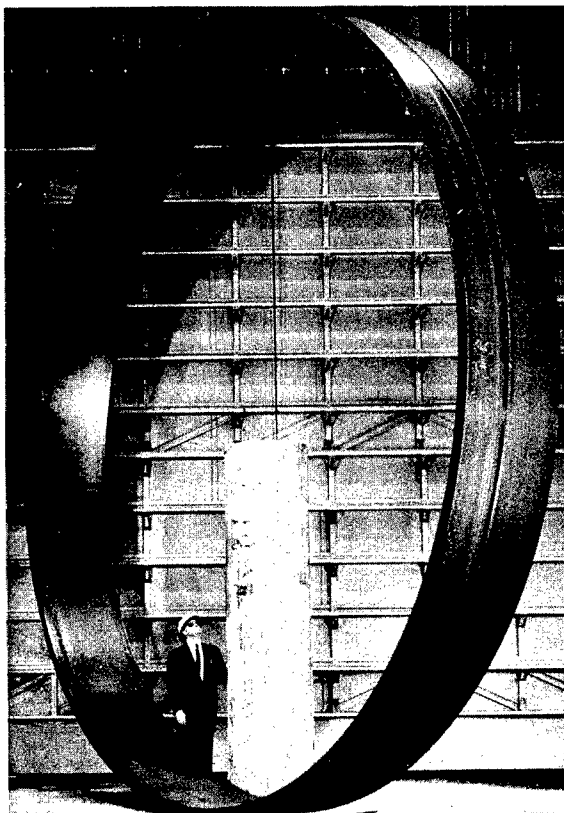

FIGURE 2.—Ring-rolled forging, 22 feet in diameter, fabricated from 18 Ni 200-grade maraging steel.

in the annealed condition and then to age it as a complete unit.

Considerable data on notched-bend fracture toughness tests with the notches in the parent metal and at various locations along the weld are given in reference 14, as well as various welding procedures. The data can only be considered comparative because changes for the better have been made both in mill processing of the steels and in fracture toughness testing procedures. The tests were made on specimens cut from 3/4-inch plate, notched and fatigue cracked to a total depth of about 0.21 inch for the 200-grade VAR steel and approximately 0.14 inch for the 250-grade air-melted material. Three-point loaded, bend test results showed that the fracture toughness of GTA welds at the center of the welds was superior to that of other types of welds. In these tests it was found that the 250-grade

plate had medium-to-heavy delaminations which appeared to affect the fracture toughness. The VAR 200-grade material, with no delaminations, was reported to have a K_{Ic} 111 ksi $\sqrt{\text{in.}}$ through the center of the value of 120 ksi $\sqrt{\text{in.}}$ in the base metal and weld; however, the banded condition of the 250-grade steel prevents a direct quantitative comparison.

The complete, fabricated motor case, shown in figure 3, was then ready for the aging heat treatment to develop the full-strength properties. For this purpose a 30-foot-diameter-by-95-foot-high furnace, large enough to accommodate the entire case, was fabricated. This was gas fired through a heat exchanger to prevent the products of combustion from coming into contact with the steel (ref. 11). The aging response of all the plates, forgings, and welds had been characterized in the laboratory, and a final compromise cycle of about 6 hours' heatup to 900° F, 8 hours' hold at 900° F, followed by air cooling, was selected as the aging treatment. The cases were successfully hydrotested under pressure to 737 psig using water inhibited with sodium dichromate. This corresponds to a calculated stress level of about 160 ksi. After hydrotesting, the cases were transported to the Aerojet facility for insulation, pouring of the propellant, and static firing tests.

The harmful effect of cracks and other flaws in high-strength pressure vessels has

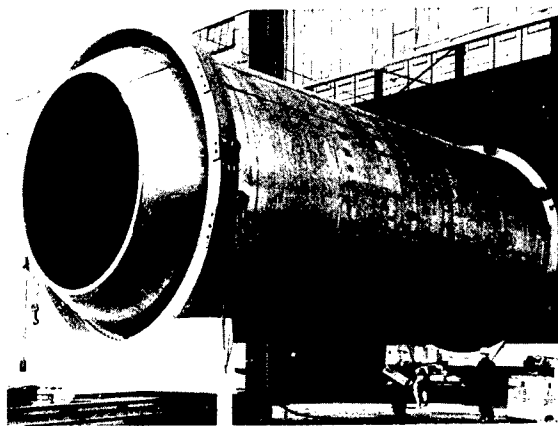

FIGURE 3.—260-inch-diameter, half-length motor case.

been mentioned. This factor created a need for reliable inspection and nondestructive testing techniques and for information on the plane-strain fracture-toughness testing. Work has been conducted in both of these fields to improve flaw-detection techniques and to develop a quantitative approach to the problem of crack tolerance in pressure vessels. Although these subjects are very important, a comprehensive discussion of them is beyond the scope of this report. For those readers who want to explore these subjects, the following key references may be of interest.

Liquid penetrant, magnetic particle, radiographic and ultrasonic inspection methods were evaluated in relation to their use on large 18 percent nickel maraging steel cases by Excelco Developments (ref. 16). This report includes a review of nondestructive testing specifications with special emphasis on ultrasonic methods. Data gathered from the 120-inch hydroburst contract and the 156-inch case contracts are discussed. A proposed process specification for ultrasonic inspection is also presented in this report. Inspection procedures are also discussed in the report on the investigation of a failure during hydrotesting of a 260-inch case (ref. 17). Two recent reports (refs. 18 and 19) indicate that this subject is still under active investigation. The program discussed in reference 18 encompasses discontinuity stress analysis, evaluation of ultrasonic inspection methods by posttest sectioning, and a detailed failure analysis. Shear wave ultrasonic testing methods proved effective in detecting and defining parent metal and weld deposit flaws. In reference 19, conventional nondestructive inspection techniques were studied and advanced techniques developed; fracture toughness and subcritical flaw growth experiments were performed. Results of these tests were combined with the results of an analysis of design deviations (e.g., weld joint mismatch) and the results of residual stress experiments to define allowable flaw sizes.

The pertinent references on fracture toughness testing are discussed in chapter 3.

Smaller, Special-Purpose Rocket-Motor Cases

Maraging steels also have been used in the fabrication of smaller rocket cases designed for special purposes and high performance. Generally these are thin-wall cases, 0.070 inch or less thick compared with the 0.40- to 0.60-inch chamber wall thickness used for the 260-inch motor cases. Maraging steels were selected for the smaller cases because of their high strength, fracture toughness, and ease in fabrication. An example of these small cases is the 9-inch-diameter case shown in figure 4. This case was manufactured by the roll-and-weld process from 0.070-inch VAR, 250-grade, 18 percent nickel sheet and two thin-wall ring forgings. It is used in an aircraft control capsule ejection system which requires very high reliability. The requirements of 3180-psig proof and 4300-psig burst pressures were easily met. The rework capability of the material was demonstrated when it was necessary to shorten some cases by several inches. This was easily done at one end, and a new forging was welded into place. Local aging of the ring forging and weld at 900° F restored the strength and the original section of the case was not affected by the change (ref. 20).

Another example is the thin-wall, 16-inch-diameter-by-120-inch-long case shown in figure 5, which is used as a booster in the High Altitude Research Project (HARP) experiments. This also is fabricated from VAR 250-grade steel. The initial impulse for these vehicles comes from the powder charge used in the 16-inch-diameter gun from which they are fired. The propellant in the rocket case is ignited by the time the projectile passes the gun nozzle, thus providing the additional thrust that enables the projectile to reach very high altitudes.

Helical welding of maraging steel strip into rocket-motor cases was investigated by the Budd Co. (ref. 21). In a previous contract with the Army, the Budd Co. had produced 20-inch-diameter-by 60-inch-long cases by helical welding of 0.040-inch-thick,

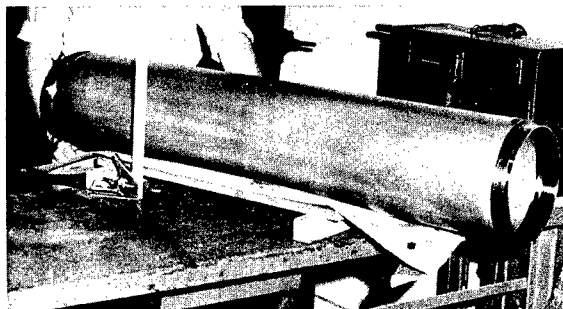

FIGURE 4.—9-inch-diameter case made from 250-grade maraging steel. (Photograph supplied by Vasco, a Teledyne company.)

18 Ni 250 grade maraging steel to form the cylindrical section. Head and end closures were fabricated separately. These cases were successfully hydrotested, demonstrating that the maraging steel, helical weld combination was a satisfactory manufacturing procedure for rocket-motor cases. The most important advantages of helically welded cases are the uniform thickness and good finish available with mill-rolled sheet, and the additional strength provided by cold reduction. The diameter of the case may also be held to very close tolerances. The tube length is limited only by the size of the coil. In this program 250-grade maraging steel coils, 0.020 inch thick by 3.596 inches wide, were aged in a vacuum furnace to a yield strength of 305 ksi. They were then helically welded into 6-inch-diameter tubes, which were cut into 24-inch-long cylinders. The hemispherical heads and aft adapters were fabricated separately and welded to the cylinders. Figure 6 (ref. 21) shows the details of the cases. Considerable experimental work was involved in developing a method to produce part-through notches on the surface of the hardened cases. The unnotched cases, as well as some with subcritical, critical, and supercritical notches, were hydrotested. The results for notched specimens are assembled in figure 7. By comparison, unnotched cases failed at hoop stresses ranging from 314 to 332 ksi. Thirty-nine cases were manufactured in this program to show that consistently high

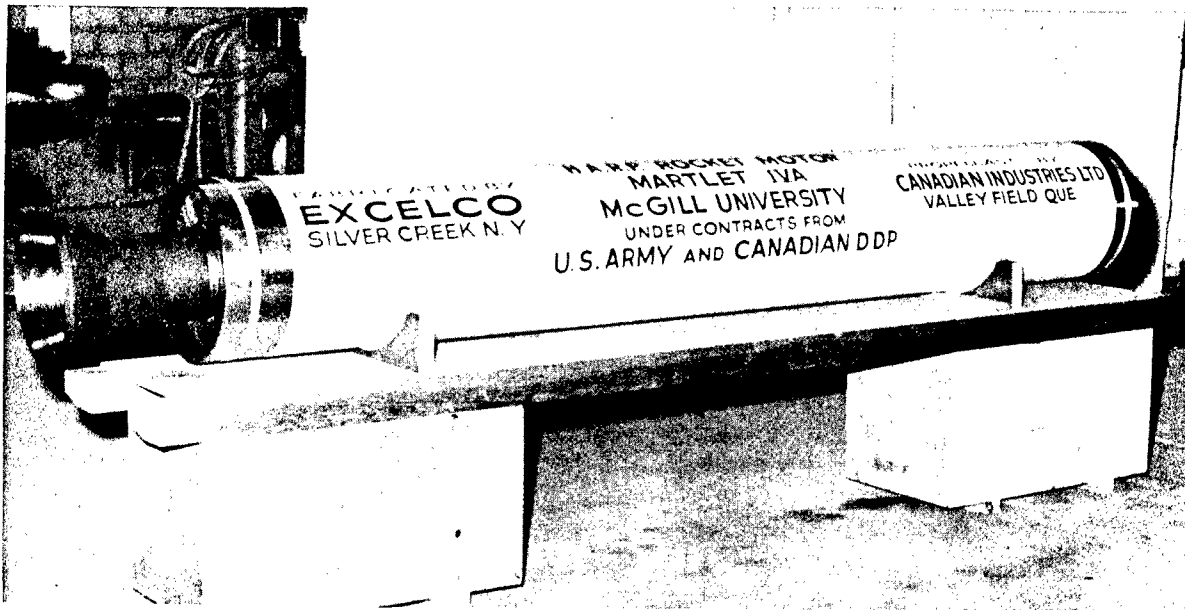

FIGURE 5.—16-inch-diameter, 120-inch-long thin-wall case fabricated from 250-grade maraging steel. Photograph supplied by Vasco, a Teledyne company.)

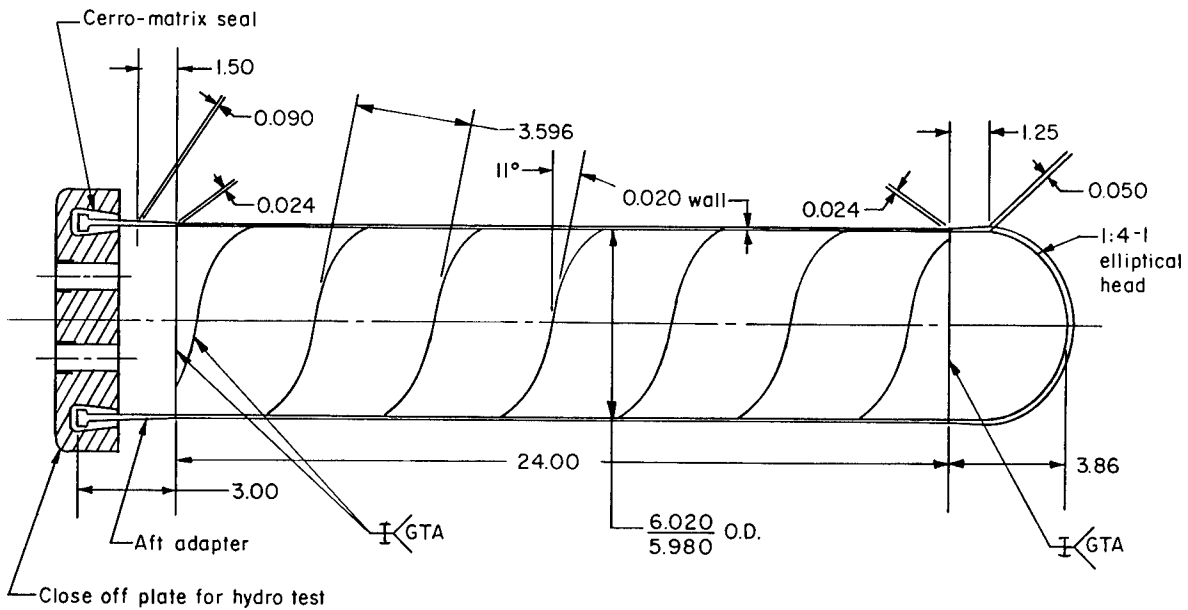

FIGURE 6.—Helically welded rocket-motor case (ref. 13).

burst strength and dimensional control could be maintained in helically welded cases.

Maraging steels, for use in a variety of rocket cases, are being evaluated in other development programs. These steels are

tabulated in a recent report by Coleman (ref. 22) on tactical missile rocket motors. The report also includes the results of an experience survey obtained by contacts with mill producers, forgers, and fabricators. The survey indicated that numerous studies

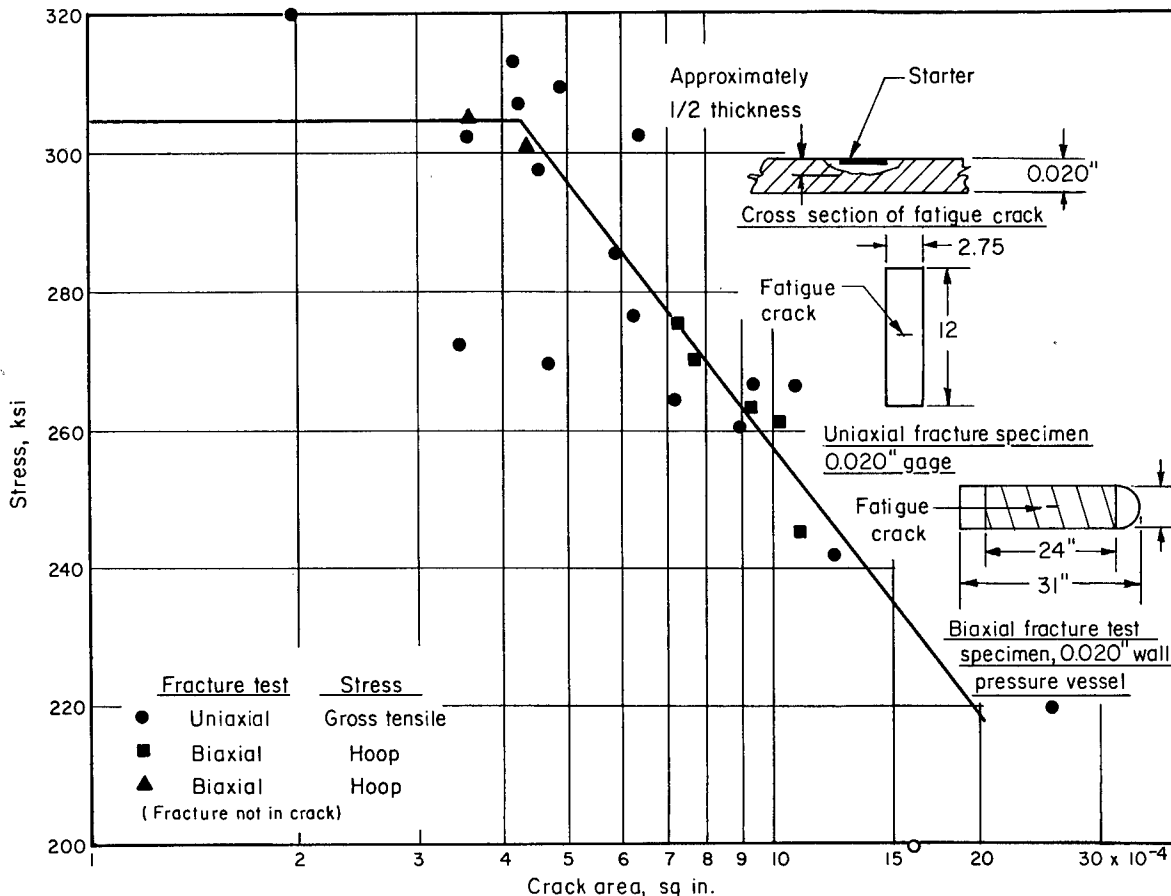

FIGURE 7.—Fracture stress versus crack area (ref. 13).

and prototype hardware programs have been conducted to define the potential problem areas in the utilization of maraging steels. Suppliers were hesitant to guarantee strengths above those specified in ASTM A 538-65 (ref. 23). The chemical composition and tensile property requirements from that specification are given in tables 2 and 3. However, progress is being made in the production of maraging steels having yield strengths of 350 ksi and above.

Fabricators and users of pressure vessels reported relatively few problems with the maraging steels (ref. 22). At the higher strength levels, the ease of fabrication and heat treatment are advantages that will permit maraging steels to replace other materials in some rocket and pressure vessel applications.

APPLICATIONS IN HYDROSPACE

Only a few references on the use of 18 percent nickel maraging steels in deep-sea environments were found in a study by Bernstein (ref. 24). Pressure hulls for deep-submergence vehicles have been fabricated from relatively low-strength but tough materials that could deform plastically in the presence of a crack without catastrophic crack propagation and failure. Some of the present submersibles, such as the *Trieste II*, are large and cumbersome and have little mobility on the ocean bottom. The pressure hull of the *Trieste II* is a steel sphere, which is heavier than the water it displaces by a factor of 2 (ref. 24).

The design of more mobile vessels capable of carrying practical payloads and men to

TABLE 2.—*Chemical Composition Requirements for Maraging Steels*^a

[From ref. 23]

Element ^b	Ladle analysis			Check analysis permissible variations, all grades, percent
	Grade A, percent	Grade B, percent	Grade C, percent	
Carbon, maximum -----	0.03	0.03	0.03	+0.005
Nickel -----	17.0 to 19.0	17.0 to 19.0	18.0 to 19.0	±.20
Cobalt -----	7.0 to 8.5	7.0 to 8.5	8.0 to 9.5	±.20
Molybdenum -----	4.0 to 4.5	4.6 to 5.1	4.6 to 5.2	±.10
Titanium -----	0.10 to 0.25	0.30 to 0.50	0.55 to 0.80	±.05
Silicon, maximum -----	0.10	0.10	0.10	+0.02
Manganese, maximum -----	0.10	0.10	0.10	+0.03
Sulfur, maximum -----	0.010	0.010	0.010	+0.002
Phosphorus, maximum -----	0.010	0.010	0.010	+0.002
Aluminum -----	0.05 to 0.15	0.05 to 0.15	0.05 to 0.15	±.03

^a Certification of compliance with the addition of these elements shall be furnished by the producer.^b In addition to the elements listed in this table, the following elements in the amounts specified shall be added to the steel: boron, 0.003 percent; zirconium, 0.02 percent; and calcium, 0.05 percent.TABLE 3.—*Tensile Requirements for Maraging Steels*

[From ref. 23]

	Grade A	Grade B	Grade C
Minimum tensile strength, ksi -----	210	240	280
Yield strength at 0.2 percent offset, ksi -----	200 to 235	230 to 260	275 to 305
Minimum elongation in 2 in., percent -----	8	6	6
Minimum reduction of area in 2-in. gage length, percent:			
Round cross-section specimens -----	40	35	30
Rectangular cross-section specimens -----	35	30	25

greater ocean depths placed some unique demands on materials (refs. 24 and 25). High strength-to-density ratios, good fracture toughness, and resistance to corrosion are the primary requirements. Nonmetallic materials used as flotation spheres are employed to reduce overall weight and weight/displacement ratios to usable levels and to provide the necessary buoyancy.

Design considerations and material properties for pressure hulls of two new deep submersibles are discussed by Schapiro (ref. 26). The oceanographic research vehicle and mobile test facility, *Deep Quest*, is the only such deep-sea submersible with a pressure hull fabricated from 18 percent

nickel maraging steel. Some of the same considerations that prompted the selection of the 18-percent nickel, 200-grade steel for the 260-inch rocket-motor cases were also applicable in the case of the submersible pressure hull, where the pressure is applied externally rather than internally. The greater toughness of the 200 grade over the 250 grade is as important to externally pressurized vessels as it is to internally pressurized rocket-motor cases. Other considerations, such as resistance to corrosion, stress corrosion, and corrosion fatigue, entered into the picture because of the salt-water environment in which the deep submersibles operate.

The pressure vessel consists of two 7-foot-diameter spheres made from 0.895-inch plate with an intersecting ring section connecting the two spheres. This provided more usable volume, better habitability, and lighter total weight than the same total volume in a single sphere. Although VAR 200-grade steel was selected as the basic material of construction, the composition was modified slightly and an aging treatment of 4 hours at 840° F was selected in an effort to obtain better toughness at the expense of some loss in strength. The material was characterized by an extensive testing program that provided the following property values:

Tensile yield strength	180 ksi min.
Tensile modulus of elasticity ..	$25.7 \pm 0.4 \times 10^6$ psi
Compression yield strength	190.6 ± 8.6 ksi
Compression modulus of elasticity	$26.8 \pm 1.2 \times 10^6$ psi
Charpy V-notch impact	40.6 ± 4.5 ft-lb
Fracture toughness	133 ± 4.7 ksi $\sqrt{\text{in.}}$
Sea-water threshold toughness .	48 ksi $\sqrt{\text{in.}}$
Fatigue notch sensitivity at $N=10^4$, $R=-1.0$	0.5 in air; 0.43 in sea water

The welds had essentially the same properties, except that the sea-water threshold toughness was higher at 78 ksi $\sqrt{\text{in.}}$. The sea-water threshold toughness figure is of interest because it is a measure of the resistance to crack propagation under plane-strain conditions in a sea-water environment. This property is identified as $K_{I_{sec}}$ in chapter 7. It should be noted that the value reported in the presence of seawater is much lower than the fracture toughness (or K_{Ic}) value in an ordinary atmospheric environment. This means that the maximum size of crack or flaw that can be present without danger of failure is much smaller in sea water than in air.

A $\frac{1}{5}$ -scale model and a full-scale pressure hull successfully completed pressure testing in an environmental chamber and *Deep Quest* is now undergoing sea trials to test its performance at depths as great as 8000 feet.

A final reference to the use of 18 percent nickel maraging steels in deep-sea water

contains specifications for a prototype buoyant vessel to be used in undersea exploration (ref. 27). The proposed vehicle is a helium-charged pressure vessel into which sea-water ballast is pumped to vary the net buoyancy. Its components are to be made from premium quality 250-grade, 18 percent nickel maraging steel. Specifications are given for maraging steel plates up to $1\frac{1}{2}$ inches thick, maraging steel forgings, maraging steel weld filler metal, and maraging steel GTA welding.

The full capabilities of the present 18-percent maraging steels were developed by improved control of composition and processing procedures. Heat treatment procedures were modified where necessary to obtain the best combination of properties. Advances in welding and other fabrication processes were made and used in various phases of the fabrication of the vessels. Inspection and testing techniques were improved to provide more reliable information on the presence and size of flaws in the metal and on fracture toughness properties. The overall effect of these improvements was a definite advance in the state of the art and knowledge of the maraging steels. This has helped to promote the use of the steels in a growing number of new applications in various fields of interest. Some of these are discussed in the following paragraphs.

TOOLING APPLICATIONS

Most of the general properties that have assured the success of the maraging steels in aerospace applications have also played a part in the selection of these steels in manufacturing of other products. These properties are high strength, simple heat treatment, good toughness, dimensional stability, freedom from decarburization during heat treatment, and good machinability and fabricability. Because of their toughness at high hardness, the maraging alloys are being used as tooling materials and for a wide variety of other industrial components (ref. 28). In some instances they provide the only material for applica-

tions requiring a combination of very high strength and toughness. In others they give increased performance and reliability.

A major use for the maraging steels in tooling has developed in die-casting operations. Core pins, cores, and dies are being used in the production of aluminum die castings with encouraging results (ref. 29). Maraging steels have shown excellent resistance to heat checking and erosion by the molten aluminum. The temperature at the die surface may reach 1000° to 1100° F; therefore, retention of hardness and strength at these elevated temperatures is a very significant factor in providing resistance to washing and heat checking. A comparative test to show the effect of 200 hours of exposure at temperatures up to 1200° F on the hardness of die block materials showed that after exposure at 1200° F, 250- and 300-grade maraging steels had a hardness of 34 to 35 Rockwell C, about 10 to 12 points higher than the other materials tested (ref. 29). Performance tests have indicated a much longer life (sometimes up to 25 times longer) for the maraging steel dies over other typical die steels. This more than makes up for the higher cost of maraging steels. Figures 8, 9, and 10 show typical die-casting tooling applications. Figure 10 shows a die made from VAR 300-grade, 18 percent maraging

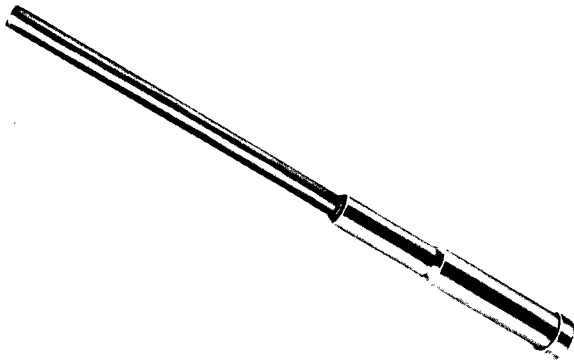

FIGURE 8.—Aluminum die casting core pin manufactured from 250-grade VAR maraging steel; $\frac{1}{8}$ -inch diameter x 12 inches long. (Photograph supplied by Vasco, a Teledyne company.)

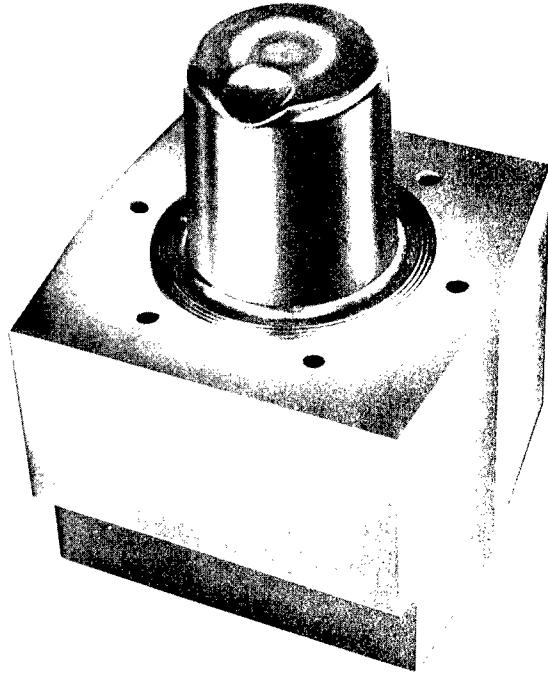

FIGURE 9.—Heavy section aluminum die casting core manufactured from 300-grade VAR maraging steel. (Photograph supplied by Vasco, a Teledyne company.)

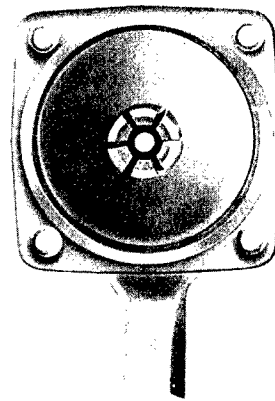

FIGURE 10.—Aluminum die casting die, 5 x 5 x 2 inches, made from 300-grade VAR maraging steel. (Photograph supplied by Vasco, a Teledyne company.)

steel. This material was chosen because the excellent finish that was required on a certain portion of the die could be readily obtained on this alloy.

Several precautions should be observed in the use of the steels in die-casting applications (ref. 30). The small shrinkage that occurs during heat treatment applies generally to simple shapes that are free of stresses induced by cold working. If stresses caused by large amounts of machining are present or suspected, they should be relieved by an annealing treatment at 1500° F, followed by air cooling, before final machining. The break-in period in the annealed condition, such as may be feasible for conventional hot-work steels, is undesirable and dangerous with maraging steels. Preferential aging and hardening of the die cavity surfaces could occur during such a break-in period if the metal surface temperature reached the 800° to 900° F range. The interior structure would remain relatively soft and the stresses accompanying such localized aging may be sufficient to cause distortion or cracking of the die.

Figure 11 is an illustration of a plastic compression transfer mold made from a block of VAR 250-grade steel. This mold measures 8 by 3 $\frac{3}{8}$ by 12 inches with a variety of holes shown in one area of the die. This is quite a complex configuration requiring a material with a fine surface finish that would not distort during heat treatment and have sufficient hardness and strength to withstand the pressures of compression molding. Aging at 900° F for 4 hours resulted in a hardness of 50 Rockwell C, with all dimensions shrinking only about 0.0008 in./in., without distortion or cracking. It was reported that no other material was suitable for this part.

Maraging steels have also been used for extrusion tools; specifically, dies, mandrels, and rams. An example of the performance obtainable from maraging steel extrusion rams is illustrated in reference 31. Here, such products as wire, rod, tubing, and other shapes are made by extrusion of a variety of metals and alloys such as zirco-

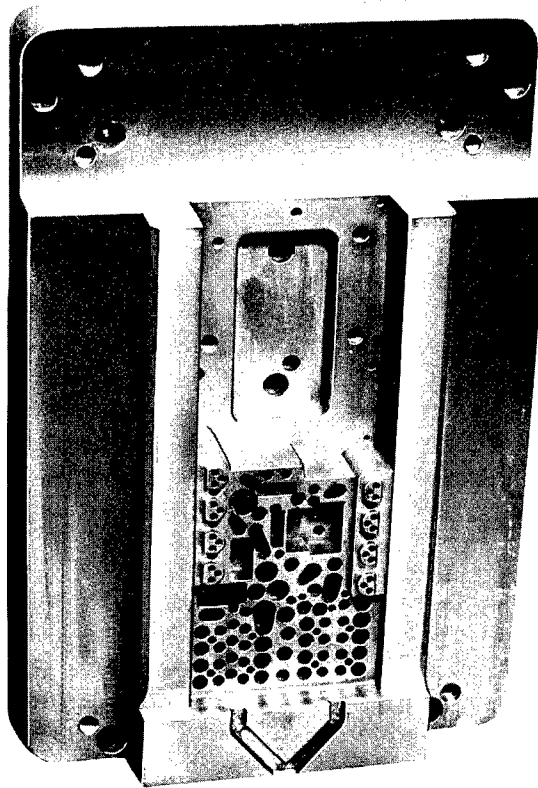

FIGURE 11.—Plastic compression transfer mold made from 250-grade VAR maraging steel. Mold dimensions are 8 x 3 $\frac{3}{8}$ x 12 inches. (Photograph supplied by Vasco, a Teledyne company.)

nium, beryllium, high nickel alloys, and similar materials. These materials are extremely stiff and require high extrusion pressures for the extrusion ratios and temperatures involved in the operations. The 300-grade maraging steel proved to be an ideal ram material for these extrusion operations. The high compressive yield strength of the 300-grade VAR steel is mainly responsible for its success. The maraging steel rams are consistently operating at applied load levels considerably higher than the limiting load of 190 ksi used with other materials. Satisfactory service has been obtained at extrusion pressures in the neighborhood of 300 ksi. Production rams in use range from 1 $\frac{1}{8}$ to 3 $\frac{1}{2}$ inches in diameter (fig. 12). Another extrusion ram application (ref. 32) demonstrating the superiority of maraging

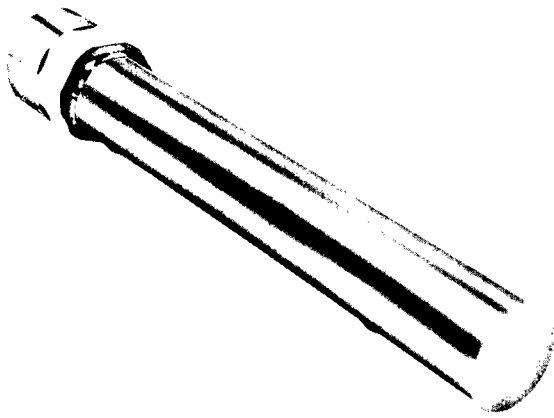

FIGURE 12.—Extrusion ram made from 300-grade VAR maraging steel. (Photograph supplied by Vasco, Teledyne company.)

steels involved the extrusion of lead or lead-tin-alloy sheaths with outside diameters down to 0.032 inch. Tool-steel rams buckled or fractured under stresses between 180 and 210 ksi, resulting in delays and additional expenses. This problem was solved through the use of 300-grade VAR rams that normally can operate at stresses of 230 ksi or more for this application. Figure 13 shows a deformed quenched and tempered tool steel ram that failed in the press, compared with its maraging steel replacement. It is clear that the higher compressive yield strength was a significant factor in this application.

An example of a die used in the extrusion of aluminum shapes is shown in figure 14. The hardness and resistance to the extrusion temperature and dimensional stability during heat treatment are the factors that led to the use of VAR 18 percent nickel, 240-grade maraging steel for this application. Maraging steel mandrels have been used in the extrusion of brasses and other copper alloys.

Other tooling applications depend on the high impact strength of the maraging steels. For example, the index plate, shown in figure 15 (ref. 33), controls drilling, spotting, milling, grinding, and boring

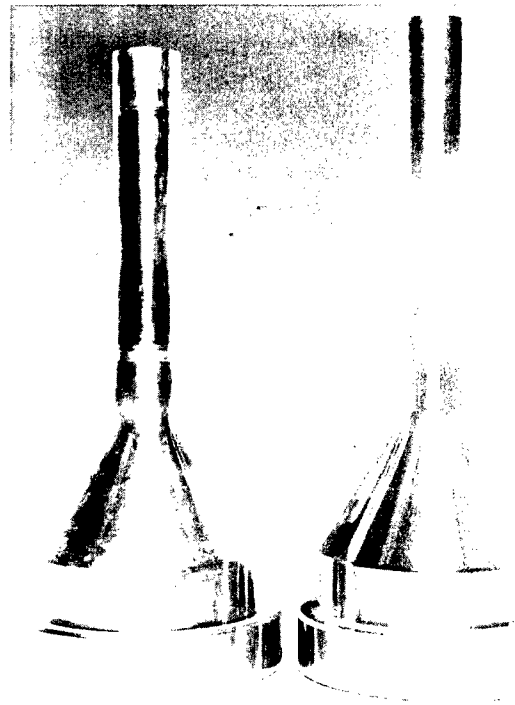

FIGURE 13.—Deformed, quenched, and tempered tool steel extrusion ram (left) compared with a maraging steel replacement. (Photograph supplied by Vasco, a Teledyne company.)

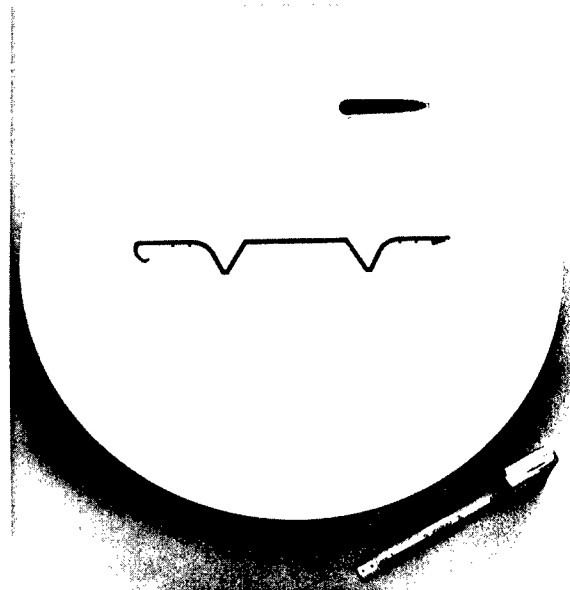

FIGURE 14.—Extrusion die for aluminum made from 250-grade VAR maraging steel. (Photograph supplied by Vasco, a Teledyne company.)

operations. These operations are controlled by a plunger which engages the teeth of the index plate. The impact of the plunger caused a failure at the root of the teeth of low-alloy steel plates after short periods of operation. VAR 250-grade maraging steel plates withstood this type of service for considerably longer periods. Other similar applications depending on the toughness and strength of the maraging steels include broaches, cold-forming punches, and punches used in cold impact extrusion of aluminum.

STRUCTURAL APPLICATIONS

Maraging steels have also found a place in structural applications. Although many of these applications are connected in some way with aerospace and aircraft, they are not necessarily dependent on the plane-strain fracture-toughness properties of the steels to such a degree as are the rocket-motor cases. The combination of high proportional limit and yield strength, ductility, flexibility, resistance to distortion during heat treatment, and ease of welding are the more important properties responsible for the successful use of maraging steels in the

representative applications discussed in subsequent paragraphs.

Modern rockets generate thrusts amounting to millions of pounds, and the accurate measurement of such high forces imposes severe requirements on the load cells used for the purpose. One such cell (fig. 16) developed for NASA's Marshall Space Flight Center is capable of measuring sustained forces of 5 million pounds. The major portion of this cell is constructed from 300-grade maraging steel, heat treated to a yield strength of 270 ksi. Another instrument developed to measure the thrust is shown in figure 17. This is a universal flexure coupling device that aligns the thrust into one or more controlled directions (ref. 34). Loading and misalignment forces are confined to highly ductile flexure webs rather than to the load cell. The webs centralize the force of the thrust into the load cells. The ability to withstand high axial loads, torque, and side loads is a critical feature in this application. The cells were fabricated from 18-inch-diameter-by-18-inch long forgings of consumable-electrode, vacuum-arc remelted, 18 percent nickel,

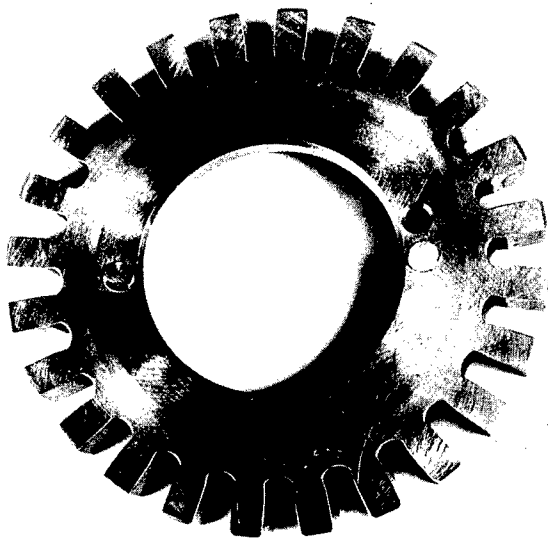

FIGURE 15.—Maraging steel index plate for mounting on a turret to control machining operations. (Photograph supplied by Vasco, a Teledyne company.)

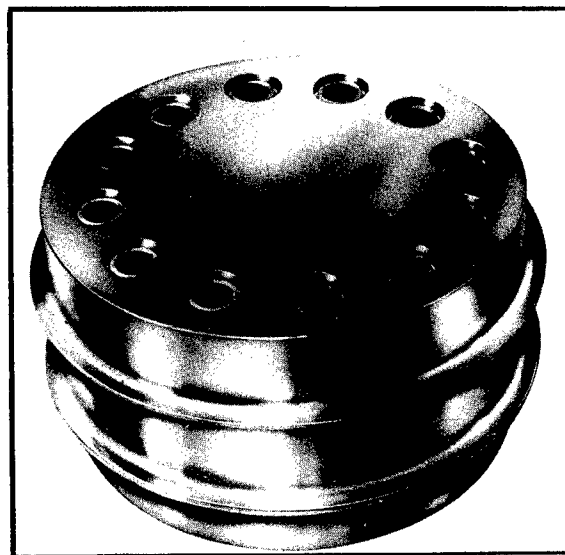

FIGURE 16.—Load cell made from 300-grade VAR maraging steel to withstand 5 million pounds force. (Photograph supplied by Vasco, a Teledyne company.)

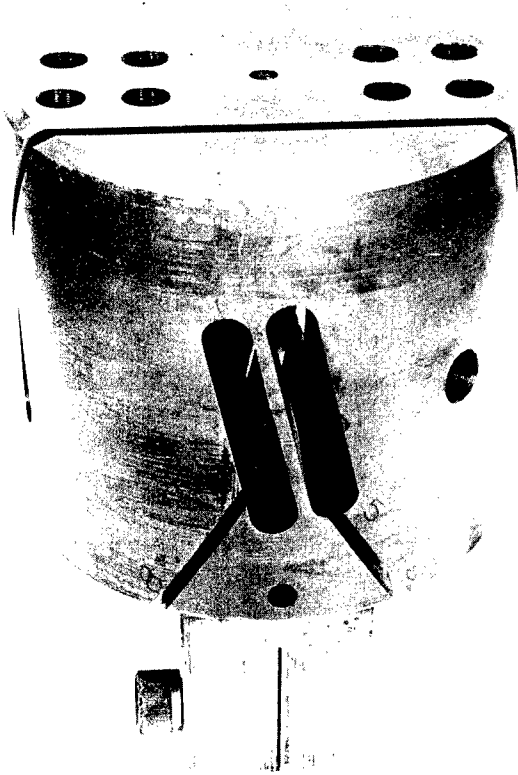

FIGURE 17.—Universal flexure made from VAR 300-grade maraging steel. (Photograph supplied by Vasco, a Teledyne company.)

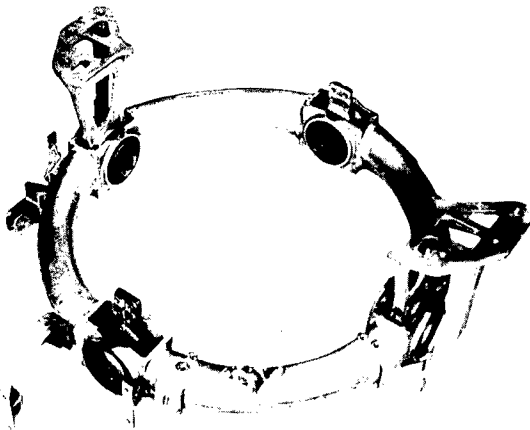

FIGURE 18.—Gimbal ring assembly employing four flexural pivots made from 18 percent nickel maraging steel. (Photograph supplied by International Nickel Co., Inc.)

300-grade maraging steel. Because of the concentration of very high forces into a relatively small area, the flexures had to be strong, ductile, tough, and machinable. The maraging steel met all these requirements. Furthermore, a proportional limit over 60 percent higher than that of other steels made it possible to reduce the size of these flexures considerably below that necessary for comparable units made from the other steels.

Another application in which flexural strength was an important factor in the selection of maraging steel as the material of construction is shown in figure 18. This is a gimbal-ring assembly employing four flexural pivots which allow a rocket engine to swivel and correct for pitch and yaw during flight. Two of the four pivots connect the gimbal ring to the airframe, and the opposing two connect the ring to the rocket engine. A double-ended type of flexural pivot is used in this device. The center section is attached either to the airframe or to the engine, and the ends support the gimbal ring. The pivot consists of a core made of two diametrically opposed, hollow cylindrical segments connected by three thin flexing members called flexures (ref. 35). Bending of the flexures permits one piece of the core to rotate in relation to the other. A view of the pivot is shown in figure 19. The 18 percent nickel maraging steel was selected for this application because of its initial high-yield strength and excellent resistance to distortion during heat treatment. The parts of the pivot must be machined to close tolerances before being assembled, since all pivots must have identical performance.

Flexural strength was also the critical property in two other applications of the maraging steels. One of these, figure 20, is a flexible shaft, made of VAR 250-grade steel, which drives the main rotor on a Hughes light observation helicopter. This is an assembly composed of a center tube spun from a small segment of bar stock, with thin, flexible, welded diaphragm packets on each end. Low work-hardening

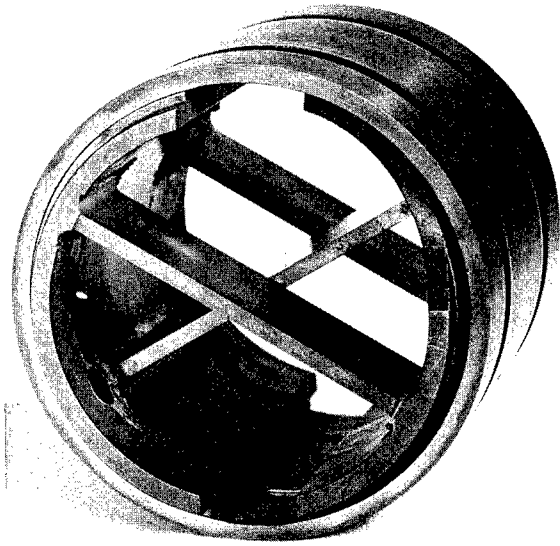

FIGURE 19.—Nickel maraging steel flexural pivot, 5-inch O.D. x 6½ long, for gimbaling rocket engines. (Photograph supplied by International Nickel Co., Inc.)

properties, lack of distortion in heat treatment, and reliability of welding were important factors in the construction of this unit. This flexible drive shaft is designed to transmit 275 horsepower at 6000 rpm with a total of 3° permissible misalignment. The use of maraging steel in this application reduced the weight of the unit and lowered the cost of manufacturing. A similar flexible shaft designed for use in aircraft turbines was judged recently to be the outstanding example of materials in design (iron-base alloys category) in the 1967 ASM Materials Application Competition (ref. 36). Angular and lateral misalignments and axial movements are accommodated by flexible joints on the ends of a two-piece shaft. Each joint consists of six hyperbolic-section disks of maraging steel formed by a single blow on a high-energy forging press and electrochemically machined to precise

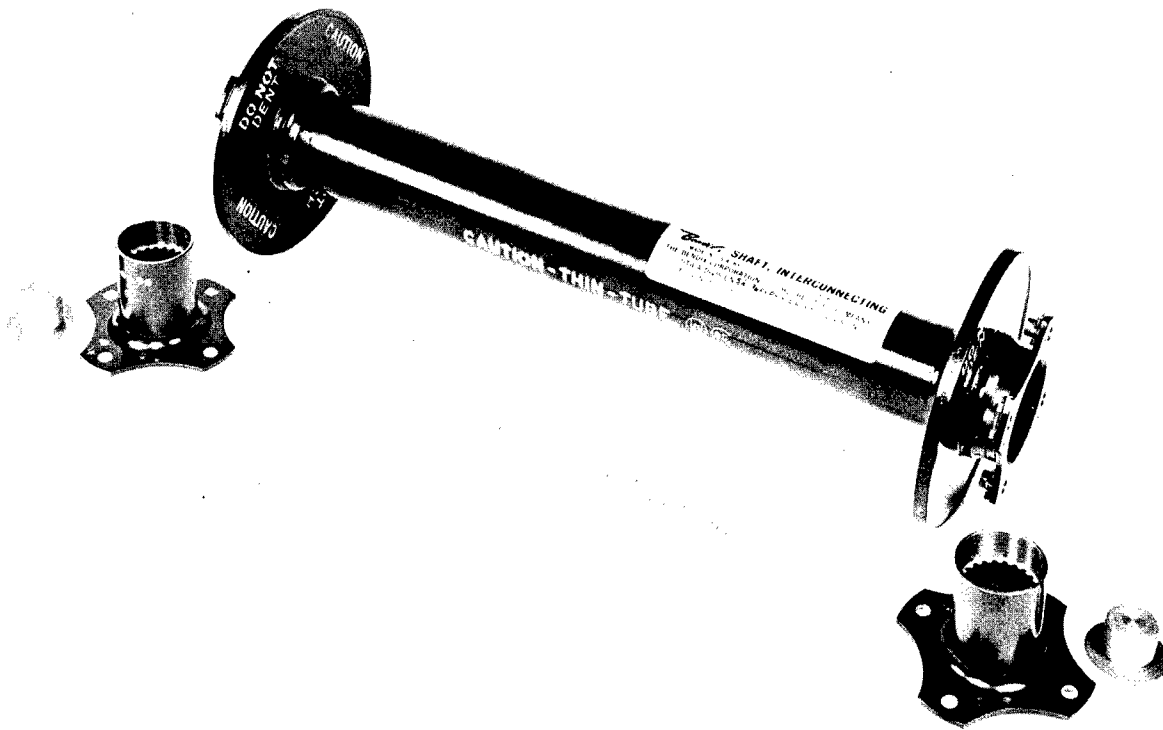

FIGURE 20.—Flexible drive shaft made from 250-grade VAR maraging steel. (Photograph supplied by International Nickel Co., Inc.)

dimensions ranging from 0.0075 to 0.0170 inch thick. Electron beam welds join the disks around their circumferences without distortion or embrittlement. The joints have exhibited unlimited fatigue life in torsion and flexure.

A heavy-duty application for maraging steel is shown in figures 21, 22, and 23. These figures illustrate the fabrication and installation of the large anchor rails that hold down the supporting columns of the mobile service tower for the Saturn 1-B vehicle at Cape Kennedy. For these rails, 18 percent nickel maraging steel, closed-die forgings were selected because of their

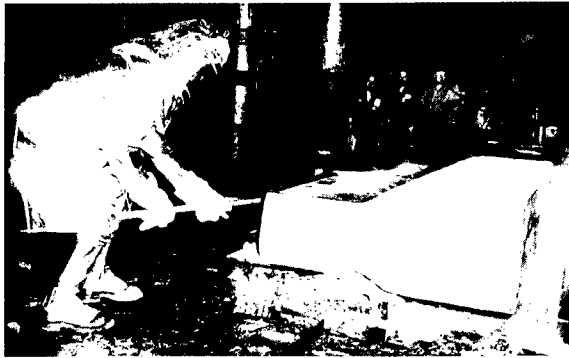

FIGURE 21.—Maraging steel billet being preformed in open die. (Photograph supplied by International Nickel Co., Inc.)

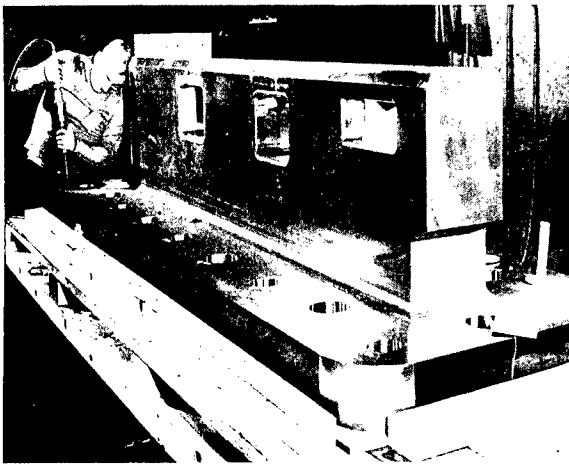

FIGURE 22.—Machined maraging steel anchor rail. (Photograph supplied by International Nickel Co., Inc.)

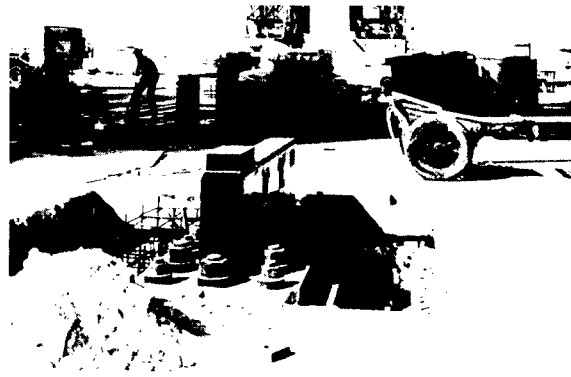

FIGURE 23.—One of the forged maraging steel anchor rails in place on launch complex. (Photograph supplied by International Nickel Co., Inc.)

ability to sustain the heavy loads and because limited space and available clearances necessitated the use of a high-strength material (ref. 37). Also, the uniform response to heat treatment provided the required properties throughout the heavy sections.

The strength and impact properties of maraging steels are used advantageously in several aircraft applications. Figure 24 shows a landing leg on the Sikorsky S 61-R helicopter. It is made from 18 Ni 250-grade maraging steel and nickel and is chromium plated to provide some protection against corrosion. This tubular component has a $3\frac{1}{2}$ -inch outside diameter and a $\frac{3}{8}$ -inch wall thickness. High strength and impact toughness were the critical properties needed for the Northrop F-5 arresting hook shown in figure 25. The shank and fitting of the hook are made from 18 percent nickel, 280-grade maraging steel. The versatility of maraging steel is demonstrated by its use as a wing hinge for a French swing-wing fighter plane. This part was fabricated by welding a combination of sheet and machined forgings to the design shown in figure 26. By using maraging steel instead of a conventional low-alloy steel, it was possible to replace an expensive 20-step heat treatment with the simple 900° F aging step. The costs saved in construction and fabrication more than offset the additional cost of the steel.



FIGURE 24.— Sikorsky S-61R helicopter landing leg made from maraging steel. (Photograph supplied by Sikorsky Aircraft.)

A considerable quantity of maraging steel was used in the construction of the Royal Canadian Navy FHE 400 hydrofoil ship, which was designed to skim the surface of the water at 60 knots on foils. A major problem in the design was to find a structural material with a high strength-to-weight ratio; the best combination of tension, fatigue, impact, and shear properties; and good weldability. VAR 250 grade was selected for the foil skin, and VAR 200 grade was selected for many of the heavy structural members in the foil and support systems. The selection of 200-grade steel for the large forgings in the foil system was based primarily on the excellent ductility and notch strength of the alloy, especially in the short transverse direction. The replaceable leading edges of the foils are made



FIGURE 25.—Maraging steel arresting hook for Northrop F-5 tactical fighter.

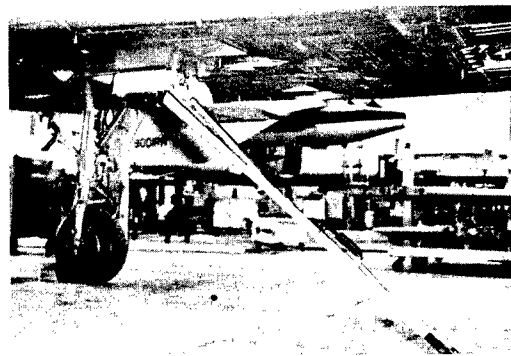

FIGURE 26.—Wing hinge fabricated by welding a combination of maraging sheet and forgings. (Photograph supplied by Vasco, a Teledyne company.)

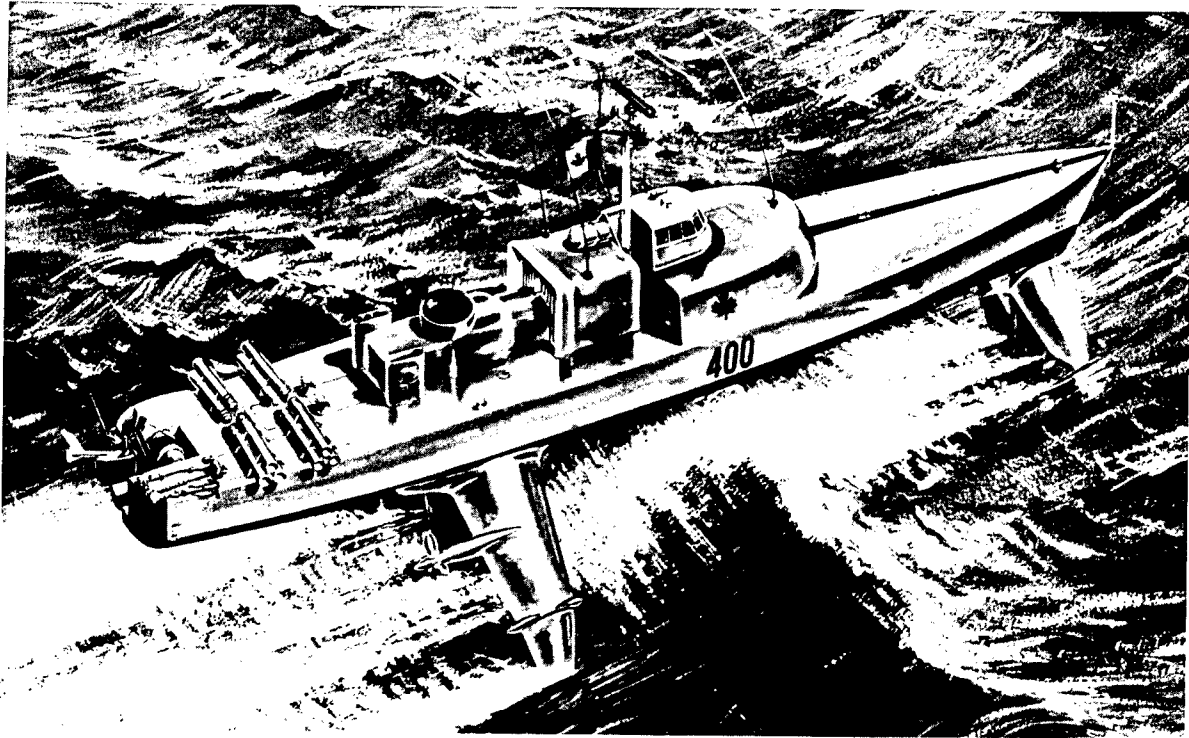

FIGURE 27.—Royal Canadian Navy FHE 400 hydrofoil ship. (Photograph supplied by Vasco, a Teledyne company.)

from Inconel 718. These foils encounter most of the cavitation erosion effects of sea water at high speed. The rest of the foil surface is made of maraging steel and is protected from erosion and corrosion by a 0.020-inch-thick organic coating. An artist's concept of the ship is shown in figure 27.

The applications discussed in this chapter illustrate the types of service conditions under which the 18-percent nickel maraging steels may be considered. They also show the fabricating procedures that may be used and the range of mechanical properties that

may be obtained intentionally by changes in chemical composition and processing variables. In most cases the reasons for the selection of maraging steels are given, and a study of these will undoubtedly suggest other applications where similar reasons may apply. Where even more demanding requirements exist, the development of the maraging steels is continuing at a rapid pace. Higher strength 350-grade maraging is already available (ref. 38), and experience and information on potential uses are being obtained.

Physical Metallurgy

AGE-HARDENABLE MARTENSITIC STEELS

The 18-percent nickel maraging steels belong to a loosely knit family of iron-base alloys that are strengthened by a combination of martensite formation followed by an aging treatment. Other members of the family include such age-hardenable martensitic stainless steels as Stainless W, 17-4PH, AFC 77, PH13-8Mo, 15-5PH, Custom 455, and AM362. Table 4 gives the compositions of these alloys together with their appropriate heat-treating schedules (refs. 39 to 53).

In all of these steels, as well as the 18-percent nickel maraging steels, the matrix will transform to martensite on cooling to room temperature directly after a solution annealing or austenitizing treatment which is carried out at an elevated temperature. (In some alloys, the transformation is made more complete by cooling to cryogenic temperatures immediately after cooling to room temperature.) The cooling rate is not critical for the maraging steels. The stainless steels usually may be air cooled when the sections are thin, but should be oil or water quenched when the sections attain appreciable thickness. When any of the steels in the family are reheated (i.e., aged) at moderate temperatures, their strength and hardness are increased.

Another alloy in the same family is Nitr alloy N, a nickel-containing nitriding steel (ref. 39). This alloy age-hardens during nitriding, an operation commonly carried out at temperatures of 930° to 1000° F.

Age-hardenable, semiaustenitic stainless steels, such as 17-7PH, PH15-7Mo, PH14-8Mo, AM-350, and AM-355, also belong to the family of iron alloys that can be strengthened by the combination of martensite formation and age hardening. However, the temperature M_s at which transformation to martensite begins for these alloys, as solution annealed, is too low to permit them to transform to martensite immediately on cooling to room temperature. Instead, they require thermal pretreatment, cold working, or refrigeration to martensitize. Compositions and illustrative thermal treatments for these steels appear in table 4.

The 20- and 25-percent nickel maraging steels mentioned in chapter 1 are also members of the family. The 20-percent nickel steel acts like an age-hardenable martensitic stainless steel, but requires refrigeration at -100° F, after cooling to room temperature, to insure complete martensite transformation. The 25-percent nickel maraging steel resembles the age-hardenable semiaustenitic stainless steels in that it is austenitic as annealed and must be cold worked, refrigerated, or given a thermal pretreatment at a moderate temperature to induce it to martensitize.

The diversity of the compositions given in table 4 is noteworthy. A considerable range of carbon contents is represented, which means that there is substantial variation in the strength, ductility, and toughness of the raw martensites that are produced on transformation of the different

TABLE 4.—Some Steels That Are Strengthened by Martensite Formation Plus Age Hardening

Designation	Nominal composition, percent										Illustrative heat treatment ^a	References
	C	Cr	Ni	Co	Mo	Cu	Ti	Al	Other			
Stainless W	0.10	17.0	7.0				1.0	1.0	0.2N		1900° F + AC + ½ hr at 950° F	39
17-4 PH	.06	16.5	4.0						0.3Cb/Ta		1900° F + OQ + 1 hr at 900° F	40
AFC 77	.15	14.5		13.5	5.0	4.0			0.5V; 0.05N		1900° F + OQ + ½ hr at -100° F + 2 hr at 1100° F	41, 42
PH 13-8Mo	.04	12.5	8.5		2.0				0.30Cb/Ta		1700° F + AC + 4 hr at 1000° F	43, 44
15-5PH	.05	15.0	4.5						0.35Cb/Ta		1900° F + AC + 4 hr at 1025° F	44, 45
Custom 455	.02	12.0	8.0			3.5	1.15				1500° F + WQ + 4 hr at 900° F	46
AM 362	.03	15.0	6.0			2.0	.75				1525° F + AC + 4 hr at 900° F	47
Nitralloy N	.25	1.0	3.5		.3			1.3			1650° F + OQ + 1 hr at 1200° F + N48 hr at 975° F	48
17-7PH	.08	17.0	7.0					1.0			1750° F + AC + 8 hr at -100° F + 1 hr at 950° F	49
PH15-7Mo	.08	15.0	7.0		2.5			1.0			1½ hr at 1400° F + AC + 1½ hr at 1050° F	49
PH14-8Mo	.03	14.0	8.5		2.5			1.1			1825° F + AC + 1 hr at 1700° F + 8 hr at -100° F + 1 hr at 950° F	50, 51
AM-350	.10	16.5	4.5		3.0				0.10N		1710° F + OQ + 3 hr at -100° F + 3 hr at 850° F	52
AM-355	.12	15.5	4.5		3.0				0.10N		1710° F + 3 hr at 1375° F + AC + 3 hr at 850° F	52, 53

^a AC=air cool; OQ=oil quench; WQ=water quench; N=nitride.

steels from the austenitic condition. The mechanical properties of the martensites are influenced also by the content of alloying elements, which varies widely. In addition, the tabulation reflects the fact that a number of elements can be used to impart aging response to the various alloys, notably titanium, aluminum, copper, and molybdenum. The implication of this fact taken together with the great variations prevailing in the compositions of the steels is that, although there are striking similarities among the members of the family regarding the schedules by which they are strengthened, important features of the underlying mechanisms responsible are likely to differ considerably from member to member. With their high nickel content and extremely low carbon content, permitting formation of an outstandingly tough martensite that can be strengthened rapidly to extraordinarily high levels, the maraging steels clearly are unique members of the family.

THE IRON-NICKEL SYSTEM

The maraging steels owe their outstanding characteristics mainly to certain specific features of the iron-nickel binary system upon which these alloys are based. The pertinent part of the iron-nickel equilibrium diagram, as determined by Owen and Liu, is shown in figure 28 (ref. 54). This diagram shows that when an alloy containing 18 percent nickel is held at temperatures of about 1100° F and above, under equilibrium conditions, its structure consists entirely of gamma (austenite). At temperatures below 1100° F the equilibrium structure is duplex, consisting of a mixture of alpha (ferrite) and gamma.

A noteworthy feature of the system, at equilibrium, is the rapidity with which the alpha-gamma phase field broadens as temperature decreases and nickel content increases. The great breadth of this field, coupled with the comparatively low temperatures involved, encourages extreme sluggishness in the transformation reactions that occur in this part of the system.

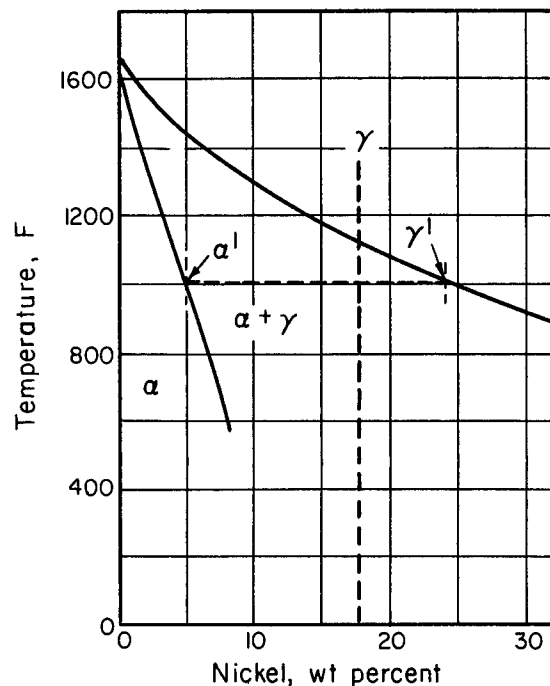

FIGURE 28.—Iron-nickel equilibrium diagram (ref. 54).

The equilibrium diagram scarcely hints at the transformation reactions actually observed in the system when normal heating and cooling rates are used. The transformation diagram in figure 29, adapted from the work of Jones and Pumphrey (ref. 55), depicts more accurately the transformation characteristics observed in practice. When this diagram is compared with the equilibrium diagram in figure 28, one can see that, on cooling, the start of the gamma-to-alpha transformation is depressed to comparatively low temperatures. By the same token, the end of the transformation is accelerated. As a result, the duplex alpha-gamma phase field is severely compressed, a situation that favors reasonably complete transformation of gamma (austenite) on cooling and discourages the development of two-phased ferrite-austenite structures as the transformation products.

Single-phased alloys generally display significantly more toughness and ductility over wider temperature ranges than multiphased materials. Thus, they are more readily pro-

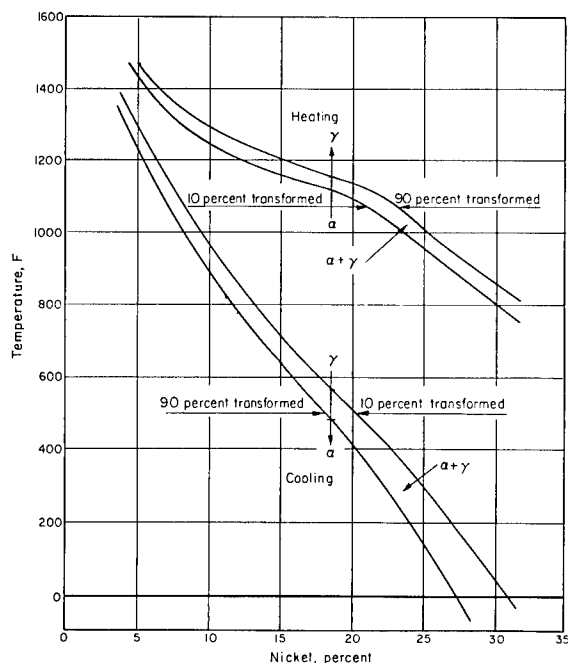

FIGURE 29.—Iron-nickel transformation diagram (ref. 55).

duced in the form of wrought mill products and are more amenable to hot working, cold forming, and welding. Furthermore, being tougher, they are more reliable structural materials.

Another important feature of the iron-nickel system is that martensite will form with normal cooling and even very slow cooling from the gamma field. Early investigators, such as Owen and Liu (ref. 54) and Jones and Pumphrey (ref. 55), noted a change in the structure of the alpha phase formed on transformation of the gamma phase in the range of 660° F and below. At the time, they did not recognize the variant structure as martensite; instead they referred to it as α_2 .

Actually, Jones and Pumphrey had reached the conclusion that the transformation in the iron-nickel system was of the diffusionless type. The significance of the diffusionless mode of transformation to martensite formation had not been established and these investigators did not associate martensite with their findings. In some of their experiments they had varied the heat-

ing and cooling rates between 2° C/min (3.6° F/min) and 150° C/min (270° F/min). Within this range of rates, they found that transformation temperature was not affected by the heating or cooling rate. They also noted that the progress of transformation on cooling could be stopped or resumed depending on whether cooling was interrupted or started again. This dependence on temperature, and lack of dependence on the rate of temperature change, suggested that the transformation was of the diffusionless type. The idea that transformation in the iron-nickel system proceeds in a diffusionless manner seems to have been first proposed by Hansen (ref. 56).

Later investigators accumulated additional information on the transformation. It now appears that at the lower nickel contents and, hence, at the higher transformation temperatures, the thermodynamic situation favors a diffusion-controlled transformation process. At higher nickel contents and correspondingly lower transformation temperatures, the extremely low diffusion rates which prevail discourage diffusion-controlled transformation. The situation then lends itself to diffusionless or shearing-type transformation. Thus, depending on the temperature, the time at temperature, and the composition, the lower nickel alloys tend to transform by diffusion to alpha, whereas the higher nickel alloys tend to transform by shearing to martensite. In effect, the diffusionless transformation which occurs at relatively high nickel contents is a short-cut method of making the transition across what would otherwise be a wide two-phase region.

The results obtained by Gilbert and Owen suggest that, at a minimum nickel content of the order of 18 percent, the transformation temperature is sufficiently depressed that martensite forms, rather than alpha (ferrite), under all conditions of cooling (ref. 57). The M_s temperature at this nickel content is about 550° F. The fact that martensite will form in the iron-nickel system is of twofold significance to the development of maraging steel. Iron-nickel

martensite is an exceptionally tough, strong matrix and an unusually well-suited host for age-hardening reactions.

An additional important feature of the iron-nickel system is brought out in figure 29. Readily discernible in this figure is the considerable hysteresis between martensite formation on cooling and its reversion to austenite on heating. This hysteresis permits reheating of the martensite to fairly high temperatures before reversion to austenite occurs, which, in turn, provides the requisite opportunity for the development of aging reactions within the martensite. To a great extent the maraging steels are the fruits of capitalizing on this opportunity.

THE MARTENSITE IN MARAGING STEELS

At nickel contents high enough to insure that the product of austenite transformation will be martensite regardless of the cooling rate, neither ferrite nor any other phase will form. The lack of alternative austenite decomposition products, formed by diffusion-controlled reactions, insures that the martensite transformation in these alloys is not disturbed by the cooling rate in the ordinary sense. Hence, section size is not a factor in the martensitization of alloys containing 18 percent or more nickel, and the concept of hardenability, which dominates the technology of quenched-and-tempered steels, is inapplicable to the maraging steels. Yet, in the iron-carbon system, ferrite and carbide phases develop whenever the cooling rate is low enough to permit these higher temperature, diffusion-controlled reactions to occur.

The fact that other phases do not form also means that tempering does not take place in the iron-nickel system on reheating. In the iron-carbon system, epsilon carbide and cementite tend to form when fresh martensite is heated.

A further implication of the fact that martensite is the only austenite transformation product in iron-nickel alloys containing some 18-percent or more nickel is that, under normal conditions, the transforma-

tion is reversible. As a consequence the grain size does not change on passing up and down through the phase transition, with the structure merely shearing back and forth between the original austenite and the descendant martensite. To refine the grain size of this type of alloy requires the development of plastic strain in the material prior to, or during, the austenitizing treatment, so that recrystallization of the austenite can be brought about. Of course, the greater the degree of straining, the greater will be the number of nuclei activated during the thermal treatment and the finer will be the resulting grain size.

In contrast, the ferritic grain size of standard plain carbon and alloy steels is subject to alteration when these steels pass through the ferrite-austenite transition, as in normalizing and various kinds of annealing treatments. This transformation provides an opportunity for grain refinement by thermal treatment because it is an irreversible nucleation and growth process, and the nucleation and growth factors can be controlled.

Iron-nickel martensite has a crystallographic structure that is essentially body-centered cubic and a yield strength on the order of 42 000 psi (ref. 58). The crystallographic structure of iron-nickel martensite is virtually the same as that of iron-nickel ferrite. The principal difference seems to be that the martensitic structure contains a tremendously high density of dislocations and may also contain fine twins depending, apparently, on the nickel content (ref. 59). In contrast, iron-carbon martensites are body-centered tetragonal, the degree of tetragonality being directly proportional to the concentration of carbon in the martensite (ref. 60). In addition, the carbon content is the dominant factor determining the strength of iron-carbon martensites.

The effect of carbon on the strength of martensite is especially dramatic at low carbon concentrations. For example, the presence of some 0.02 percent carbon increases the yield strength of raw iron-nickel

martensite to the vicinity of 100 000 psi (ref. 61). A yield-strength value of about 95 000 psi has been obtained for an iron-nickel-carbon martensite containing 30.8 percent nickel and 0.02 percent carbon (ref. 62).

Now the martensite formed in the 18-percent nickel maraging steels is also reported to be essentially body-centered cubic (ref. 63). In fact it is considered to be a type of martensite known as massive martensite, which is characterized by a high dislocation density, the absence of twins, and blocky irregularly shaped grains having the appearance of ferrite (ref. 59). Little wonder that the earlier investigators passed it off as a type of ferrite—in a sense it is.

Yield-strength values on the order of 95 to 119 ksi have been reported for the 18-percent nickel type of maraging steel when in the as-martensitized condition (refs. 63 and 64). Therefore, as a first approximation, the martensite in the 18-percent nickel maraging steels can be considered as behaving in the same way as an iron-nickel-carbon martensite containing about 0.02 percent carbon. Apparently, such elements as molybdenum, cobalt, titanium, and aluminum do not make their presence felt to an appreciable extent with respect to the strength of the martensite. However, even though present in relatively small concentrations, carbon seems to be of great importance. It is possible also that nitrogen may contribute substantially toward strength. If small amounts of carbon and, perhaps, other elements have a profound effect on the strength of the martensite developed in the 18-percent nickel maraging steels, then indeed the mechanical properties of this type of steel must be regarded as extremely composition sensitive.

AGING REACTIONS

When the maraging steels are heated to moderate temperatures, but below the temperature range of rapid reversion to austenite, their hardness and strength increase markedly. For example, an 18-percent nickel maraging steel with a yield strength of

100 000 psi, on being aged 3 hours at 900° F, may reach a yield strength of 250 000 psi. This is an aging response of outstanding magnitude.

Moreover, the hardening response of these steels during aging is rapid. For instance, the hardness of a steel containing 19 percent nickel, 7 percent cobalt, 4.9 percent molybdenum, and 0.4 percent titanium was 28 Rockwell C as annealed; however, after only 3 minutes at 900° F the hardness had risen to 43 Rockwell C and then gradually increased to 52 Rockwell C over a total time period of 3 hours at 900° F (ref. 63). Rapid response is quite common in age-hardening or precipitation-hardening systems.

The practical effect of rapid aging response is to introduce an element of inflexibility into the heat treatment of age-hardenable alloys. The tendency is toward the existence of a rather narrow temperature band in which it is worthwhile to age the alloy. For the 18-percent nickel maraging steels, this band ranges from about 750° to some 950° F. At lower temperatures, little change will occur in the properties unless the time at temperature is greatly extended. At higher temperatures, the processes which detract from the desired aging effects set in quickly, and optimum combinations of mechanical properties do not have a chance to develop. Furthermore, within the preferred aging-temperature range, the various processes which occur start off so rapidly that it is generally impractical to try to interrupt them in order to develop intermediate combinations of mechanical properties.

Taken together, these characteristics mean that in any effort to achieve a given set of mechanical properties, the extent to which the heat-treating schedule can be altered to compensate for undesired composition variations is quite limited. By contrast, the tempering processes which take place in conventional hardenable steels offer wide latitude in the development of mechanical properties. Most quenched, medium-carbon, low-alloy steels show significant property changes on being tempered

in a range extending from about 300° to 1300° F and above. Here, one has considerable opportunity to vary the heat-treating schedule to compensate for a nonoptimum chemical composition in the development of a desired set of mechanical properties.

Identity of Precipitates

The mechanisms responsible for the increase in strength that takes place in the 18-percent nickel maraging steels during the aging treatment have been the subject of considerable investigation. It was quickly recognized that the shapes of the curves obtained for the changes occurring in mechanical properties as a function of time at constant aging temperature were comparable to those for precipitation-hardenable alloys. However, early X-ray and electron diffraction studies failed to positively identify a precipitant or other mechanism, although an ordering reaction was offered as a possibility (ref. 64).

In another effort to identify precipitates in maraging steels, an extraction replica was made from an 18-percent nickel maraging steel that had been aged 3 hours at 900° F after being annealed 1 hour at 1500° F and air cooled; i.e., the standard heat treatment (ref. 65). An electron micrograph of this replica revealed a host of small discrete particles, shown in figure 30, which the investigator believed to be responsible for the age hardening of the steel. The electron diffraction pattern obtained from these particles fit the diffraction pattern for Ni_3Mo . Electron-microprobe analysis of the particles indicated the presence of Mo, Ni, Fe, Ti, and Co. Combining the evidence, and taking into account the uncertainties involved in the methods and measurements, the author hypothesized $(\text{Ni, Fe, Co})_3\text{Mo}$ as the precipitate with the titanium being present as $\text{Ti}(\text{C, N})$.

In later research using thin-section electron microscopy, two types of precipitate were observed in an 18-percent nickel maraging steel of typical composition heat treated according to the standard procedure;

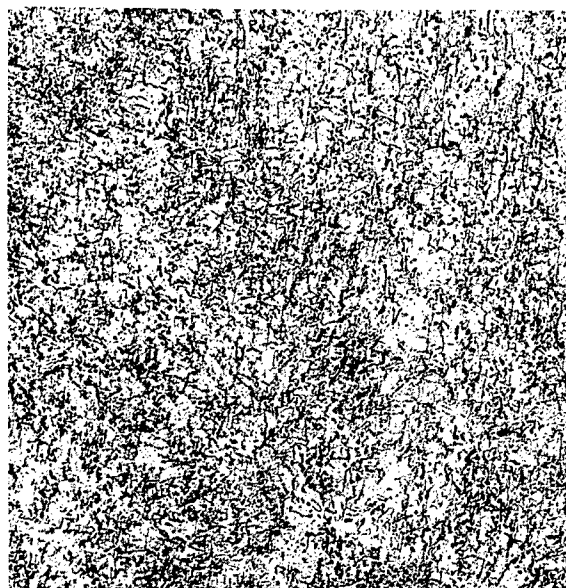

FIGURE 30.—Age-hardening precipitate in maraging 250-grade steel. Electron micrograph of extraction replica (ref. 65) $\times 70\,000$.

i.e., 1 hour at 1500° F, air cool, plus 3 hours at 900° F (ref. 66). One precipitate took the form of ribbons situated on dislocation lines and at the martensite subboundaries, whereas the other appeared as small, isolated particles distributed homogeneously throughout the matrix. X-ray diffraction studies of this steel, and two experimental alloys similar to the commercial steel, except that one contained no Ti and the other no Al, led to the conclusion that the ribbon-shaped precipitate was Ni_3Mo , and the finer precipitate was a titanium compound tentatively identified as Ni_3Ti .

Another research study aimed at establishing the hardening mechanisms operative in the 18-percent nickel maraging steels encompassed the use of thin-foil, electron-microscope studies of fully aged material and the use of extraction replica techniques, as well as an electron-microprobe analysis of overaged material (ref. 67). Included in the materials studied were a steel of standard composition and a series of experimental alloys of simplified composition with each hardening element deleted in turn. The conclusions drawn from the results obtained were: (1) that hardening resulting from

titanium is effected by the development during aging of zones of order based on a metastable Ni_3Ti structure which becomes a Widmanstätten Ni_3Ti precipitate on overaging; and (2) that hardening resulting from molybdenum comes about by the formation of face-centered, cubic-disk-shaped zones during aging which become a spheroidal precipitate of Fe_2Mo on overaging.

Still another group of investigators concluded that two precipitates were involved in the age-hardening process (ref. 68). By means of electron diffraction measurements and electron-microprobe analyses made on extraction replicas, these investigators identified one precipitate as Ni_3Mo and the other as possibly Ni_3Ti .

In a recent paper dealing with a transmission electron microscope and electron diffraction study of the strengthening precipitates in the 18-percent nickel maraging steels, orthorhombic Ni_3Mo was reported to be the primary precipitate (ref. 69). The secondary precipitate was reported to be tetragonal FeTi sigma phase. The experimental materials had been annealed at 1500° F and aged at 900° F.

Two other papers go far toward unscrambling what might appear, at this point, to be a considerable controversy over the identity of the precipitates involved in the age hardening of the 18-percent nickel maraging steels. In one paper, it was noted that a marked additional hardening component was operative at the lower temperatures and longer aging times in an 18 Ni-8 Co-5 Mo alloy, which did not exist at higher aging temperatures (ref. 70). It was further observed that the presence of this component required the matrix to be highly supersaturated with molybdenum and that it took the form of a finely distributed precipitate evidently not nucleated at dislocations. It was speculated that this precipitate might be analogous to the molybdenum-rich clusters observed in the binary Fe-Mo system and might correspond to the fine spherical particles that other investigators have tentatively identified as a

titanium-rich compound. On the basis of additional observations, the authors further speculated that this precipitate may be unstable compared with the one observed in other research studies to form at dislocations and, hence, would dissolve as aging proceeded and the later precipitate developed and grew.

Thus, by suggesting that three precipitates may be involved and that one of them may be transient, the results of this investigation offer a viable explanation of the somewhat conflicting conclusions that have been reached in studies of precipitate identity.

The second paper reported phase identification studies based on Mössbauer spectroscopy (ref. 71).¹ The Mössbauer effect is the recoilless, resonant emission and absorption of gamma rays by atomic nuclei. Because of a fortunate combination of parameters, the recoilless fraction for the Fe^{57} isotope favors studies of the Mössbauer effect in iron at room temperature, and the natural abundance of Fe^{57} is sufficient to make enrichment unnecessary. A thin specimen containing Fe^{57} is placed between a suitable source of gamma rays and a detector. Absorption is measured by moving the specimen relative to the source, which results in a Doppler shift of the gamma-ray energy and permits the production of patterns showing transmitted energy as a function of relative velocity. The characteristics of the patterns are influenced by the quantity, composition, and magnetic susceptibility of the phases present.

By means of Mössbauer spectroscopy, the authors found the martensitic matrix of a commercial 18-percent nickel maraging steel to be depleted in solute on aging 3 hours at 900° F. Because they observed no paramagnetic peak in the spectrum (which would indicate the presence of iron in the new phase), they considered their finding consistent with the supposition that the pre-

¹The research described was supported in part by a traineeship conferred on one of the authors by NASA.

precipitate that had formed was Ni_3Mo ; however, as the technique does not easily detect a slightly ferromagnetic precipitate, the phase could also have contained some iron. In material aged 34 hours at 995°F , they found the precipitate to be Fe_2Mo . Thus, these investigators also found evidence of an early transient precipitate that gave way to a more stable one in the course of aging; in addition, their results suggest the transition from the first precipitate to the second might be effected by a change in the composition, rather than by the resolution of the first precipitate in the matrix.

In summary, it seems plausible to hypothesize that the strengthening occurring in 18-percent nickel maraging steels on aging results from the early formation of zones or clusters based on an Ni_3Mo grouping containing iron (i.e., $(\text{Ni}, \text{Fe})_3\text{Mo}$) which, at higher aging temperatures, may give way or evolve into a precipitate of Fe_2Mo . At the lower aging temperatures and the longer holding times, the clusters may perhaps be supplemented by the Fe_2Mo precipitate. It is also hypothesized that a third precipitate containing titanium forms in the promotion of age hardening in these steels. Most likely, this precipitate is FeTi sigma phase.

The changes produced in a commercial 18 Ni 250 grade of maraging steel, as a function of aging time and temperature, are shown with dramatic clarity in figures 31 and 32 (ref. 70). The steel contained 18.39 Ni, 4.82 Mo, 7.83 Co, 0.02 C, 0.35 Ti, and 0.07 Al and had been annealed 1 hour at 1500°F before being aged. Figure 31 shows how electrical resistivity changes, and figure 32 illustrates the effect of aging on the hardness of the material.

The resistivity curves show a small decrease at short aging times due probably to the partial recovery of the martensite defect structure. The large decrease in resistivity that follows is characteristic of precipitation of solute from solid solution. When the data in figure 31(a) are plotted on a linear time scale, as in figure 31 (b),

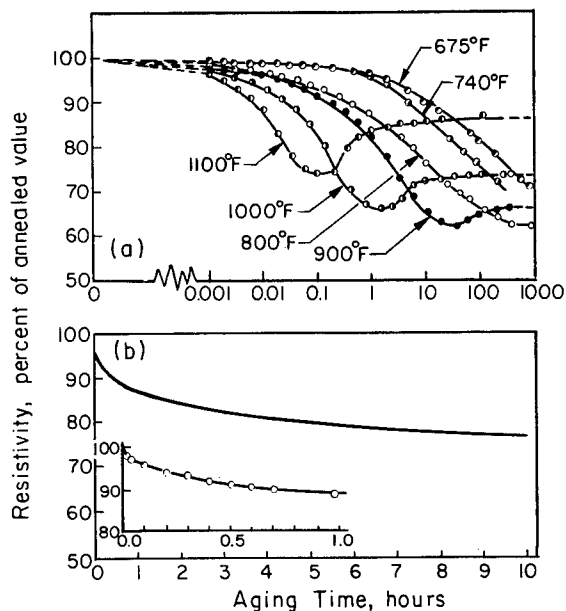

FIGURE 31.—(a) Effect of aging time and temperature on the electrical resistivity of a commercial maraging steel. (b) Linear time plot of resistivity decrease at 800°F from the data of (a) (ref. 70).

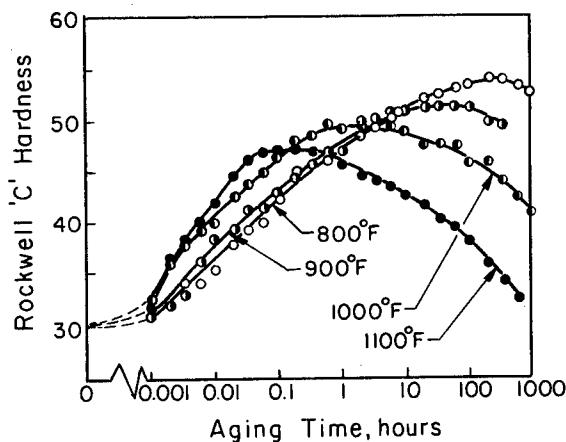

FIGURE 32.—Effect of aging time and temperature on the hardness of a commercial maraging steel (ref. 70).

no incubation period is seen for the aging process because it occurs at temperatures of 800°F and above. Thus, a nucleation rate is not involved at these temperatures, the rate of reaction depending entirely on the

precipitate growth rate. At lower aging temperatures, however, there may well be an incubation period. The upturn in resistivity, to be noted in the 900°, 1000°, and 1100° F curves, marks reversion to austenite which is a prominent factor in the overaging of the maraging steels. Overaging is taken up in a later section.

From figures 31 and 32 it is seen that a great increase in hardness, hence strength, accompanies the precipitation processes, and, of course, the rates of precipitation and of hardening increase with increasing aging temperature. By the same token, the onset of overaging occurs earlier at the higher aging temperatures. In this connection, it is of interest to note that hardening may occur even though reversion to austenite is taking place at the same time. This is particularly evident in the 900° F curves where austenite formation began at about 10 hours (fig. 31), while the attainment of peak hardness required about 100 hours (fig. 32).

The Role of Cobalt

The role of cobalt in the age hardening of the 18-percent nickel type of maraging steel has been as much of an enigma as the identity of the precipitates responsible for the hardening. In early research on these steels, it was found that an alloy containing 18.9 Ni, 5.4 Mo, and 7.0 Co could attain a hardness of 50 Rockwell C on aging, although a similar alloy without cobalt was able to reach a hardness of only 40 Rockwell C (ref. 63). On the other hand, an alloy containing 7.0 Co and no Mo showed no aging response and only a hint of solid-solution hardening attributable to the cobalt. Thus, the cobalt seemed to be making some kind of indirect contribution to age hardening that required the presence of molybdenum to be operative.

Electron-microprobe analyses made by subsequent investigators on extraction replicas from annealed and aged material generally revealed very little, if any, cobalt in the precipitates considered responsible for the strengthening that occurs when the

steels are aged (refs. 65, 67, and 68). Likewise, in the work done with Mössbauer spectroscopy, cobalt was not found to be a component of any of the precipitates that developed in the maraging steel specimens (ref. 71). Finally, in none of the programs that have made use of electron diffraction or X-ray diffraction techniques has a precipitate been observed with characteristics coinciding with any cobalt compounds. These various observations have confirmed the earlier deduction that cobalt does not play a direct role in the precipitation reactions that occur in the 18-percent nickel maraging steels.

It has been shown, however, that a minor amount of age hardening can actually be induced in iron alloys containing 18 Ni, to which some 5 to 15 Co has been added (ref. 64). Because no precipitate formed during aging, it was speculated that the hardening may have resulted from ordering. Evidence has been found that ordering occurs in an alloy of iron containing 22.7 Ni and 19.3 Co (ref. 72).

By far the largest contribution of cobalt to the strength of the 18-percent nickel maraging steels is the synergistic effect that occurs in conjunction with the addition of molybdenum. Apparently, the cobalt-molybdenum interaction is unique; no such interaction has been observed in cobalt-containing alloys with additions of aluminum, beryllium, columbium, manganese, silicon, or titanium (ref. 73). At low molybdenum contents, in the region of 1 percent, the interaction effect is nonexistent or weak, and any strengthening noted may be the result of a combination of solid-solution hardening and ordering. In a steel containing 8 Co and 1 Mo, the increment in strength is about 25 ksi, but at the level of 5 percent molybdenum, the addition of 8 Co results in a strength increment on aging of about 75 ksi over that developed in the cobalt-free steel (ref. 73).

A clue to the part played by cobalt in the precipitation process is obtained by comparing the transmission electron photomicrographs of the Fe-20 Ni-5 Mo and the

Fe-18 Ni-8 Co-5 Mo alloys (see fig. 33) aged 24 hours at 800° F (ref. 73). The precipitation is fine and clearly evident in the cobalt-containing alloy, but is not extensive in the cobalt-free alloy. Floreen and Speich, who conducted the investigation, called attention to the fact that the simplest explanation of the effect is that the presence of cobalt lowers the solubility of the precipitant in the matrix (ref. 73). Miller and Mitchell expressed the same hypothesis this way: “. . . the addition of cobalt reduces the solubility of molybdenum in the iron-base matrix and this results in formation of a larger volume-fraction of finely dispersed precipitate” (ref. 67).

More recent research confirms the supposition that the addition of cobalt decreases the solubility of molybdenum in the matrix, the addition of 8 Co corresponding to about an additional 2 Mo precipitated from solution (ref. 70). The development of the third hardening component discovered in the course of this study, and mentioned in the preceding section, was attributed to the molybdenum supersaturation brought about

by the addition of cobalt. Other effects of the cobalt-induced supersaturation, according to the authors, are to promote precipitation without the need for an initial incubation period and to accelerate the entire precipitation process. Cobalt also retards the reversion of martensite to austenite.

Thus, although cobalt may make a minor contribution to the strength of the 18-percent nickel maraging steels through solid-solution hardening and through ordering occurring during aging, the overriding contribution of this element is through its effect on the solubility of molybdenum in the martensitic matrix. By increasing the molybdenum supersaturation, a new finely dispersed precipitate develops, the volume fraction of precipitate is increased, and the precipitation-hardening process is accelerated, all of which adds up to a substantial increase in the strength increment produced by aging.

REVERSION TO AUSTENITE

When the 18-percent nickel maraging steels are heated for extended periods of

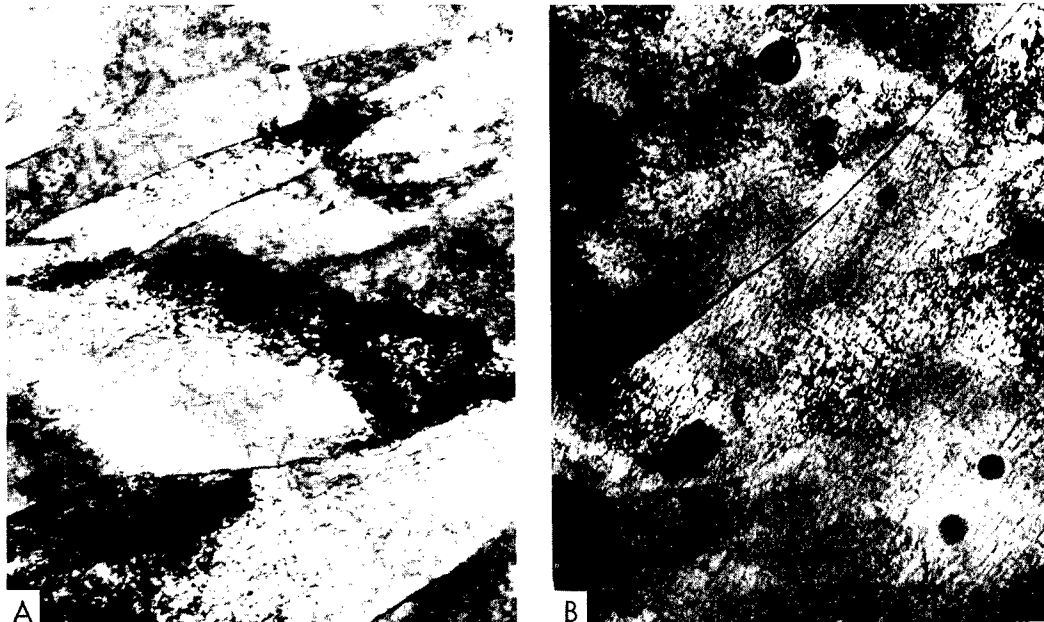

FIGURE 33.—Comparison of transmission electron micrographs of (A) Fe-20 Ni-5 Mo and (B) Fe-19 Ni-8 Co-5 Mo alloys. Aged 24 hours at 800° F (ref. 73). $\times 40\,000$.

time at the higher aging temperatures, i.e., overaged, the matrix tends to revert to austenite. The same thing happens on heating at temperatures between the aging range and the annealing range. The extent of reversion depends on the time and the temperature. For example, in one research program the investigators noted a thin continuous phase in light and electron micrographs of a commercial 18-percent nickel maraging steel aged 10 hours at 900° F, which they considered to be reverted austenite (ref. 68). Greater amounts of the phase were seen in material aged 100 hours at the same temperature, and an X-ray diffraction study indicated the presence of 14 percent austenite in the specimen.

In the course of an earlier investigation, 3 percent austenite was found in a steel aged 5 minutes at 1000° F, whereas 6 percent austenite was developed by extending the aging time to 30 minutes (ref. 74). By heating 1 hour at 1200° F, a structure containing 50 percent austenite was obtained. In another study, substantial amounts of reverted austenite were observed in material aged 10 hours at 1000° F (ref. 65).

In displaying austenite reversion upon being heated at intermediate temperatures, the steel is behaving in accordance with the dictates of the equilibrium diagram for the iron-nickel system, as shown in figure 28. In the martensitic form, the 18-percent nickel alloy is in a metastable condition, as described by the iron-nickel transformation diagram in figure 29. This metastable state holds indefinitely at room temperature and at moderate temperatures above ambient. However, as the temperature is increased, the martensitic condition becomes increasingly unstable and the tendency to establish true equilibrium (fig. 28) becomes stronger. At perhaps 900° F and above, diffusion rates have increased sufficiently to permit the system to move toward the condition of equilibrium at appreciable rates.

In achieving equilibrium, the reaction which takes place is the conversion of martensite into ferrite and austenite having

compositions controlled by the temperature at which the reaction occurred. Thus, as shown in figure 28, upon reheating an 18-percent nickel steel at 1000° F for a period long enough to establish equilibrium, ferrite of composition α' and austenite of composition γ' are formed from the previously existing martensite. It is seen that the ferrite is leaner in nickel and the austenite is richer in nickel than the prior martensite. On cooling back to room temperature, the ferrite does not transform to martensite. In addition, the austenite may be sufficiently enriched with nickel that it becomes stable and therefore does not transform to martensite. To return the austenite to a transformable condition, it is necessary to reheat in the single-phase gamma region where the austenite can be restored to its original composition.

The austenite-reversion phenomenon in these steels has several implications of practical importance, most of which stem from the fact that the austenite which is formed tends to be too stable to retransform to martensite on subsequent cooling. Thus, this stable austenite neither contributes to martensitic hardening nor to the additional strengthening developed when the martensite is subsequently aged. Its presence in the steel, then, promotes reduction in strength and, accordingly, is undesirable.

One implication of austenite reversion is that after the process has gone forward to a sufficient extent, it contributes to overaging in the steel. To judge from such evidence as that depicted in figures 31 and 32, depending on the aging temperature, reversion to austenite and formation of the precipitates responsible for age hardening can proceed simultaneously. The net result is a continued gain in strength until a peak strength is reached, after which classical overaging (excessive precipitate particle growth) sets in (ref. 70). Some time thereafter, the degree of austenite reversion becomes sufficiently significant for this process to make its contribution to the softening of the metal. The addition of cobalt retards austenite formation; as a result, the amount

of austenite present at the point of peak strength is substantially less than that in cobalt-free material (ref. 70).

Again, the reversion phenomenon imposes limitations on the thermal treatments to which these steels can be subjected. Intermediate and process annealing treatments at moderate temperatures are ruled out, as are moderate-temperature, stress-relieving treatments. When the steel is to be conditioned or softened for further fabrication, it must be given a full anneal; i.e., heated well into the single-phase austenite region, as indicated in figure 29.

The austenite-reversion phenomenon is of particular significance with respect to welding. Austenite reversion can be avoided during aging and during annealing. However, a narrow region inevitably develops in weld-heat-affected zones where reversion to austenite has occurred. In this connection, Petersen's studies, which have been reported by Decker, are pertinent (ref. 75). Petersen prepared expanded, simulated, weld-heat-affected zones in an 18-percent nickel maraging steel using a high-speed time-temperature device. With a high-

speed dilatometer attachment he obtained curves of dilatation versus heating rate from which he could observe the transformations which occurred and the manner in which they were influenced by the heating rate. The results are shown in figure 34. At high heating rates, an A_s temperature² was noted, and martensite began to revert to austenite at this temperature. As the temperature was raised above A_s , reversion proceeded further and reached completion at the A_f temperature.³ This reversion took place by means of a shearing mechanism.

At heating rates below 400° F/sec, a diffusion-controlled reaction appeared to occur before the start of the shearing process. This, as shown in figure 34, was the conversion of martensite into low-nickel ferrite α' and high-nickel austenite γ' . As mentioned earlier in this discussion, the high-nickel γ' resist transformation back to martensite on subsequent

² The temperature at which reversion to austenite begins.

³ The temperature at which reversion to austenite is theoretically complete.

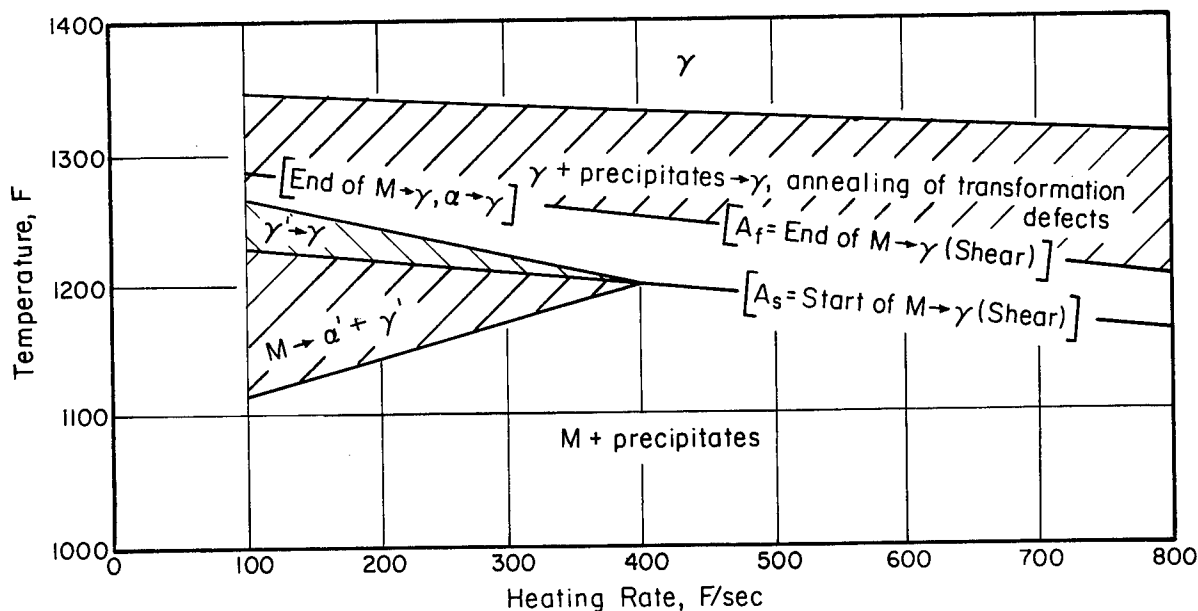

FIGURE 34.—Effect of heating rate on reversion to austenite in 18 percent nickel maraging steels (ref. 75).

cooling. Decker has reported that loss in strength is proportional to the percentage of γ' in the structure (ref. 75). At higher temperatures, Petersen again found an A_s temperature where the shearing reaction began. Heating just above this temperature caused the γ' to become rehomogenized to the original unstable γ , which would then retransform to martensite when the steel was cooled back down to room temperature. Somewhat above the A_s temperature, the α' formed at lower temperatures was converted to γ and, thus, the process of austenite reversion was completed.

Decker reported that, in these studies, the reverted austenite grain size was the same as that of the austenite which was present during the previous anneal. Even the diffusion reactions yielded products which were so oriented that they eventually joined to re-form the prior austenite grain (ref. 75).

Petersen found a small loss in strength in the artificial heat-affected zones because of the presence of the region of stable austenite. The extent of the loss depended on the amount of γ' present and this, in turn, could be varied by varying the dwell time in the temperature range in which martensite decomposes to α' and γ' .

THERMAL TREATMENT OF MARAGING STEELS

Annealing

It is to be noted from figure 29 that an 18-percent nickel-binary alloy must be heated above 1150° F to be completely transformed to gamma. With their additional alloy content, the 18-percent nickel maraging steels must be heated to a minimum temperature of about 1350° F to assure complete transformation to austenite.

In practice, the 18-percent nickel maraging steels are annealed at temperatures considerably above this borderline value. Annealing at a temperature on the order of 1500° F dissolves precipitates and promotes relief of internal residual stresses developed during hot working, cold working, or joining. Double-annealing schedules

such as heating at 1650° F and then reheating at 1525° F, or heating at 1750° F and then reheating at 1400° F, improve the strength and toughness of the subsequently aged material.

The casting grade of maraging steel is given a high-temperature-homogenizing anneal before the age-hardening treatment (refs. 76 and 77). The reason is that, in common with other highly alloyed cast materials, this steel is quite inhomogeneous chemically in the as-cast condition and as such, does not respond uniformly to the age-hardening treatment. The condition is not eliminated by annealing at the temperatures used for the wrought maraging steels; diffusion rates are too low at these temperatures, and soaking at very high temperatures is necessary. The usual treatment is 4 hours at 2100° to 2200° F. Heating the cast steel 4 hours at 1800° F plus 1 hour at 1100° F, followed by 1 hour at 1500° F before age hardening is recommended for the development of a fine grain size in the casting.

Age Hardening

In experimental investigations of the 18-percent nickel maraging steels, a wide range of aging conditions was used. Temperatures have ranged from below 700° F to as high as 1200° F, with times extending to 1000 hours. In industrial practice, however, the aging temperature usually employed is 900° F; the amount of time generally is 3 hours, although it has been extended to as long as 10 hours. The 3-hour treatment at 900° F is economical, and, although it does not produce peak strength, this schedule generally results in an optimum combination of strength, ductility, and toughness.

INFLUENCE OF COLD WORK

Because they combine considerable ductility with a very low work hardening rate, the 18-percent nickel maraging steels are capable of drastic cold reduction. The low rate of work hardening probably can be attributed to the extra-low carbon content

of the steel's martensitic structure, making little interstitial material available to pin dislocations.

In one study (ref. 63), annealed bar stock was cold rolled in various amounts up to 90 percent reduction of area. The resulting change in hardness is shown in figure 35; from this it is seen that 90 percent cold reduction brought about a hardness increase of only 6 points Rockwell C. In the same study, another series of bars was first cold rolled from 50 to 90 percent and then aged 3 hours at 900° F. The yield strengths obtained are shown in figure 36. The increase in the yield strength of this particular material from 220 to 295 ksi was accomplished without impairing ductility. To place this mechanical property change in perspective, it should be said that the same amount of cold reduction in a chromium-nickel stainless steel of the AISI 301

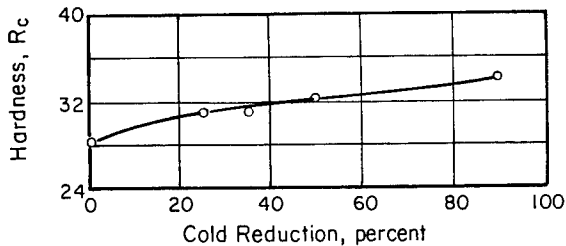

FIGURE 35.—Effect of cold working on the hardness of an 18.5 Ni-7.0 Co-5.0 Mo-0.4 Ti maraging steel bar annealed 1 hour at 1500° F and air cooled before cold rolling (ref. 63).

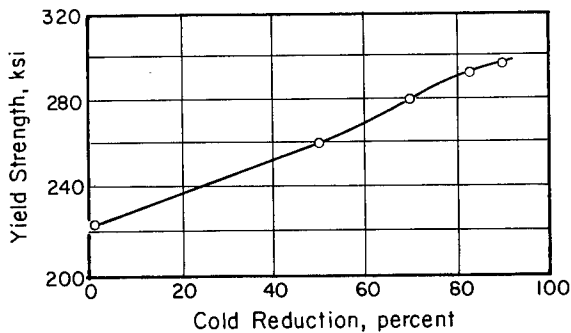

FIGURE 36.—Effect of cold working on the yield strength of 18.5 Ni-7 Co-5 Mo-0.1 Ti maraging steel bars annealed 1 hour at 1500° F, air cooled, cold rolled, and aged 3 hours at 900° F (ref. 63).

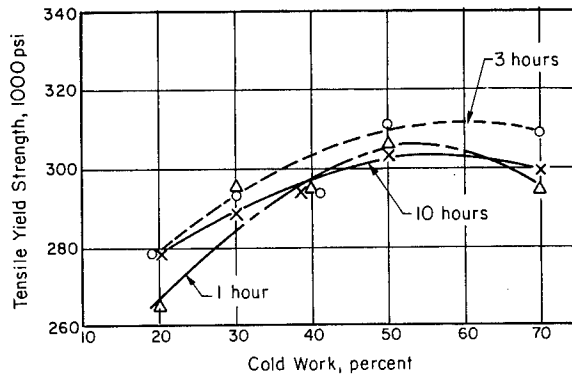

FIGURE 37.—Effect of cold working and aging time at 900° F on the yield strength of 18 Ni 250-grade maraging steel (ref. 78).

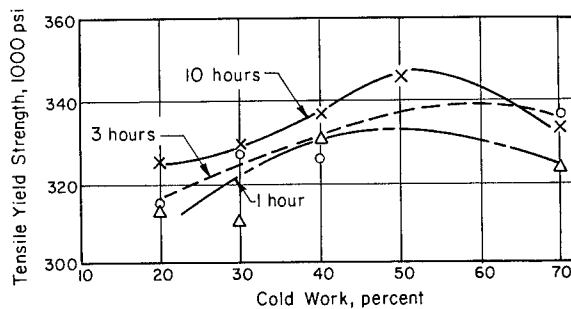

FIGURE 38.—Effect of cold working and aging time at 900° F on the yield strength of 18 Ni 300-grade maraging steel (ref. 78).

type,⁴ subsequently stress equalized at 800° F, would have produced approximately a fivefold increase in its yield strength.

In numerous investigations, data have been generated that relate to the effect of cold working on the mechanical properties of the 18-percent nickel maraging steels. Some of these investigations have been researches on cold working alone, whereas others have been concerned with the fabrication of components and end items by cold-forming methods. Portions of the accumulated data are presented in figures 37 and 38 (ref. 78). The data show that the strengths of both the 250 and the 300 grades of 18-percent nickel maraging steel

⁴ Designation of the American Iron and Steel Institute for the standard 17 Cr-7 Ni austenitic stainless steel.

are increased by cold working prior to aging. In these steels maximum strength was obtained when the metal was cold reduced about 50 percent. In all cases the magnitude of the increment in strength was significant but modest.

It is logical to suppose that the main reason the increments in strength have been observed in the cold-worked material after aging is that the work-hardening effect was retained, in whole or in part, during the aging treatment. However, in a recent paper on the electrical and magnetic properties of maraging steels an additional reason is suggested (ref. 79). In this investigation, as shown in table 5, it was observed that a moderate amount of cold working not only influenced the hardness of 18 Ni 250 grade material but also significantly reduced coercive force and resistivity. The author considered that the most plausible explanation of the reduction in coercive force and electrical resistivity was to assume the

TABLE 5.—*The Influence of Deformation on Properties of 18 Ni 250 Grade Maraging Steel After Annealing 30 Minutes at 1650° F*

[From ref. 79]

Deformation, percent	Hardness, VHN	Coercive force, oe	Electrical resistivity, microhm-cm
0	307	22	68.2
15	315	14	63.1

original annealed material contained some retained austenite which was transformed to martensite by the subsequent straining. Although this explanation probably could not account for all of the hardness increase noted, it could explain some of it. Transformation of retained austenite could be a factor in the improved strength effected in material aged prior to cold working, since martensite is a far more cooperative matrix for precipitation-hardening reactions than is austenite.

BANDING AND NONMETALLIC INCLUSIONS

Shortly after 18-percent nickel maraging steel plate became available, it was often observed that fractured tensile test specimens that were oriented in the longitudinal direction of the rolled plate exhibited longitudinal splits parallel to the rolling direction and plane. The same kind of phenomenon appeared in plane-strain fracture-toughness test specimens and on the edges of thermally cut plates. Metallographic examination of polished cross sections cut longitudinally through these splits revealed no unusually high concentrations of nonmetallic inclusions associated with them. However, etching metallographic specimens taken from numerous plates generally revealed a banded microstructure; the degree of banding varying from extremely mild to moderate, as shown in figure 39 (ref. 80), to unbelievably severe, as illustrated in

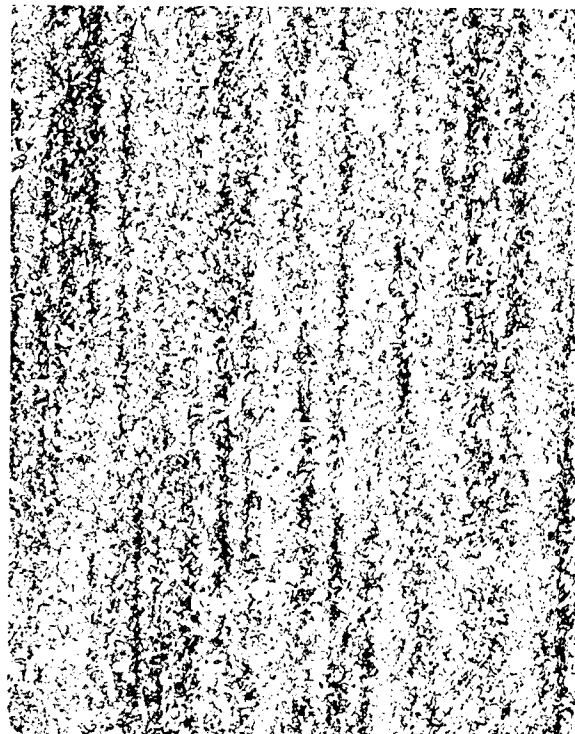

FIGURE 39.—Moderate degree of banding observed in consumable-electrode vacuum-arc-remelted 18 Ni 300-grade maraging steel plate (ref. 80).



FIGURE 40.—Severe banding observed in air-melted 18 Ni 250-grade maraging steel plate (ref. 81).

figure 40 (ref. 81). The splitting was associated with the more severe banding.

Reaction to the etchants used in optical metallography suggested that the white bands observed when the degree of banding was quite severe, as illustrated in figure 40, were austenite. It was deduced that this austenite was not reverted but residual, having persisted through the conversion operations from the ingot stage. Evidently, then, such bands must have represented regions in the ingot where the content of nickel was considerably higher than the average for the material, high enough, in fact, to make the austenite completely stable. By analogy, the dark etching bands, common to all degrees of banding, also would reflect chemical inhomogeneity in the ingot, though perhaps different from, or less pronounced than, that giving rise to the austenite bands. Such chemical inhomogeneity, of course, would stem from inter-

dendritic segregation occurring during solidification of the ingot.

Confirmation of the inferred chemical inhomogeneity is found in an electron-microprobe investigation that was made of severely banded plates (ref. 81). Some of the results obtained are shown in table 6. Analysis was also made for cobalt in the different bands, but no evidence of significant segregation of this element was found.

It is significant to note that banding, even the severe type, has not been detrimental to the tensile properties and fracture toughness of material in the longitudinal or in the long transverse direction of flat-rolled products. Thus, this phenomenon has not seemed to affect the performance of 18-percent nickel maraging steel sheet and strip. However, the presence of bands (or laminations as they are often called) drastically reduces fracture toughness in the short transverse (or through-the-thickness) direction, thereby seriously impairing the capability of plate of any appreciable thickness to function properly as an ultra-high-strength structural material (ref. 81).

The standard heating and hot-working operations used to convert ingots to plates do not promote, or permit, a sufficient amount of diffusion to eliminate the original interdendritic segregation prevailing in the

TABLE 6.—*Electron-Microprobe Analysis of Bands in Maraging Steel Plate*

[From ref. 81]

Area analyzed	Percent of concentration			
	Ni	Mo	Ti	S ^a
White bands (austenite)	20.2	6.3	0.81	100
Dark bands -----	19.4	5.0	.56	91
Light bands (matrix) --	17.6	4.3	.38	77
Average bulk material -	18.0	4.7	.44	.012

^a Suitable sulfur standards were not available for calibration in percent. Therefore, the figures represent relative amounts using 100 units as the sulfur content of the austenite.



FIGURE 41.—Aluminate stringer found in air-melted and vacuum-degassed 18 Ni 250-grade maraging steel plate (ref. 80) $\times 450$.



FIGURE 42.—Titanium sulfide inclusions found in consumable-electrode vacuum-arc-remelted 18 Ni 250-grade maraging steel plate (ref. 80) $\times 80$.

ingot. The principal effect of the metal flow that occurs during these operations is to change the shape of the segregate pattern; as the ingot section is reduced to plate thickness, the segregate regions are elongated and flattened parallel to the rolling plane and direction.

In an effort to obliterate banding, the effect of a nonstandard, high-temperature homogenizing treatment carried out on finished plate was studied (ref. 81). The material was soaked 16 hours at 2300° F, air cooled, and then annealed at 1500° F and aged at 900° F. The segregation was eliminated, but the toughness of the steel was generally impaired. The fractures of test specimens were now largely intergranular, occurring along prior austenite grain boundaries shown by electron microscopy to be

depleted of age-hardening precipitates. Thus, such a high-temperature soaking treatment could not be considered a satisfactory solution to the banding problem. However, as is mentioned in chapter 4, changes have been made in production practices that have alleviated the situation.

Although nonmetallic inclusions have not been generally associated with the splitting, or delamination, phenomenon discussed above, gross concentrations of aluminate stringers have been deduced to be the cause of some of the laminations discovered in plates by nondestructive testing techniques (ref. 80). Gross formations of stringers have been observed in vacuum-arc remelted steels and in air-melted material; titanium sulfides have also been identified in these steels. Examples of these types of nonmetallic inclusion are shown in figures 41 and

42. However, nonmetallic inclusions have not posed serious problems in the production and application of these steels.

In a recent study of nonmetallic inclusions in air-melted and in vacuum-arc remelted material, titanium carbonitrides (containing zirconium), titanium sulfides, titanium-molybdenum compounds (tentatively identified as carbides), and titanium carbides

were identified in both materials (ref. 82). The authors suggested that the presence of titanium carbides at prior austenite grain boundaries may detract from toughness, whereas tying up hardening elements, such as titanium and molybdenum in the form of nonmetallic inclusions, tends to reduce the capability of the steel to develop full strength.

CHAPTER 4

Manufacture of Mill Products

In 1960, production of the maraging steels was oriented almost exclusively toward military and Government application. The principal mill products were sheet, plate, and wire for inert-gas-shielded arc welding. Some quantity of forging billets also was produced.

These alloys have found an increasing number and diversity of applications in the civilian economy, and a complete range of standard and special mill products, including bar shapes, rod, and tubing, in addition to plate, sheet, and strip, has become available. Today, perhaps 60 percent of the tonnage produced per year finds civilian applications, while 40 percent is used in military applications.

Accurate figures on the annual production of the maraging steels are not available; however, it is estimated that approximately 6000 tons were produced through 1965. It is probable that some 2500 tons were produced in 1966 and that the rate during 1967 was at the level of about 3000 tons per year.

The maraging steels are processed in the mill on the same equipment and by the same general procedures as are used in the production of mill products from other high-quality alloy steels. Very few precautions need to be taken in production that are peculiar to the maraging steels (ref. 83).

MELTING

The 18-percent nickel maraging steels have been air melted in basic electric-arc furnaces. In some cases the air-melted heats have been deoxidized according to

the recommended procedure of adding 0.05 percent Ca, 0.02 percent Zr, and 0.003 percent B and then poured into ingot molds. In some cases, the heats were deoxidized with silicon and aluminum, whereas, in other cases, the metal was tapped into ladles which were transferred to vacuum chambers for degassing before being deoxidized with calcium, zirconium, and boron, and teemed into ingot molds (ref. 84).

These alloys also have been air melted in electric-arc furnaces and cast in the form of cylindrical electrode ingots, which were then remelted by the consumable-electrode, vacuum-arc process. In some cases, the air melts have been vacuum degassed before being poured into electrode-ingot molds. In addition, the electroslag (Hopkins) process has been used to remelt air-melted electrode ingots. Finally, the maraging steels have been vacuum-induction melted, air melted and then remelted by the vacuum-induction process, and double vacuum-induction melted (ref. 84).

The size of air-melted arc-furnace heats has ranged from 15 to 85 tons. When vacuum-melting processes have been used, the heats have varied in size from less than a ton to 15 tons and more. Ingots teemed from air melts have been as large as 32 inches by 60 inches and weigh 50,000 pounds, although a frequent size for consumable-electrode, vacuum-arc remelted ingots is 33 inches in diameter, with a weight of 30 000 pounds (refs. 83 and 84).

The composition of the alloy in terms of the major elements can be controlled satis-

factorily by air melting in the electric-arc furnace. Even the contents of carbon, sulfur, phosphorus, manganese, and silicon can be held to the desired low levels with this process (ref. 85). However, the gaseous elements oxygen, nitrogen, and hydrogen cannot be reduced to low concentrations, nor can volatile impurities such as arsenic, bismuth, and lead be eliminated. Moreover, the nonmetallic inclusions present in the air-melted metal tend to be large and non-uniformly distributed. In particular, some of the titanium that is added as a major age-hardening element is used up in forming oxide, nitride, and carbonitride inclusions and, thus, is not available to contribute to the strengthening of the steel. Also, the titanium-containing inclusions tend to form stringers in the finished product that detract from ductility and toughness, particularly in the transverse direction.

Vacuum degassing offers an opportunity to reduce the concentration of the gaseous elements, notably hydrogen, that are present in air-melted steel. Both the vacuum-induction and the consumable-electrode vacuum-arc remelting processes provide a better opportunity to remove hydrogen, nitrogen, and the volatile impurities. However, when the metal to be remelted by either of the vacuum processes already contains such strong deoxidizers as Al, Ti, Zr, or Ca, the remelting operation has little or no effect on the carbon and oxygen contents (ref. 85). On the other hand, when the deoxidizers are added late, as can be done easily in vacuum-induction remelting, then the carbon and oxygen contents are capable of further control beyond that afforded by air melting. The sulfur, phosphorus, and silicon contents are not affected significantly by vacuum remelting, whether by the consumable-electrode or the induction process.

The spraying action of the arc generated in the consumable-electrode, vacuum-arc process makes possible the breaking up of large masses and clusters of nonmetallic inclusions into small, fairly uniformly dispersed particles (ref. 85). In this finely divided form it would be expected that the

nonmetallic inclusions would do the least harm to the mechanical properties of the steel.

Another important distinction between the consumable-electrode vacuum-arc melting process and the other melting methods is in the production and freezing of the ingots (ref. 83). In air melting and vacuum-induction melting, the molten metal is rapidly poured into the mold where it freezes from the sides inward and the bottom upward, and then from the top downward, while the still-molten metal is moving about inside as a result of complex thermally induced convection currents. Solidified in this manner, it is possible for the metal to display considerable chemical inhomogeneity of a fairly gross character. In vacuum-arc remelting, the melting crucible is also the ingot mold, which means that the ingot is produced and frozen in a progressive manner, with freezing starting at the bottom and moving steadily to the top. The molten pool under the arc is turbulent and promotes mixing not only of the nonmetallic inclusions, but also of the elements comprising the matrix; the result is that although little homogenization with respect to the alloying elements and other constituents can occur along the length of the ingot, a great deal can occur transversely as long as the molten metallic pool is not too large.

In general, the producers have selected from the available melting procedures those which produce metal of the required quality at the lowest cost. Air melting in the electric-arc furnace is the least expensive procedure, air melting followed by vacuum degassing is more expensive, and procedures calling for vacuum-arc or vacuum-induction remelting are the most expensive (ref. 83). The usual methods used for the 18 Ni 200 and 18 Ni 250 grades are air melting in the electric-arc furnace or air melting followed by consumable-electrode, vacuum-arc remelting. With regard to the 18 Ni 250 grade, there is some inclination to consider that vacuum-arc remelting may be a better method when plane-strain fracture tough-

ness or resistance to stress-corrosion cracking is critically important. The maraging steels of higher strength, such as the 18 Ni 300 and 18 Ni 350 grades, are almost always consumable-electrode vacuum-arc remelted.

INGOT BREAKDOWN

It does not appear necessary to give 18 Ni maraging steel ingots any special post-teeming treatment because they do not appear subject to cracking when air cooled after being stripped from the molds. The probable reason for this freedom from cracking under such circumstances is the ductility of the martensite formed on transformation during cooling. One practice has been to strip 3 to 8 hours after teeming and then allow the metal to air cool to room temperature (ref. 84).

However, like other metallic materials containing large amounts of alloying elements, the maraging steels are subject to considerable dendritic segregation on freezing, regardless of the melting method or the manner in which the ingot is cast. Nickel, molybdenum, and titanium segregate to the extent that the austenite in the interdendritic regions tends to remain stable to room temperature (ref. 86). These highly alloyed regions persist through forging and rolling, and elongate during these operations so that in etched sections they take on the appearance of streaks or bands. Because they contain more nickel, molybdenum, and titanium, the 18 Ni 250 and the 18 Ni 300 grades have a greater tendency toward banding than the 18 Ni 200 grade.

The presence of these bands in the end product reduces the ductility and the tensile strength in the direction perpendicular to the bands (ref. 85). Fracture toughness in the plane parallel to the bands also tends to be reduced. Again, severely banded sheet and plate are susceptible to delamination; i.e., splitting along the bands during certain cutting, forming, and testing operations.

The dendritic segregation that leads to the development of bands containing large concentrations of alloying elements is not

influenced by melting practice itself; however, because this type of segregation is affected by the solidification rate, the condition can be alleviated by changes in the casting practice. Moreover, it can be controlled to some degree by homogenization treatments and by the procedures used for ingot breakdown (ref. 87).

To homogenize the material by diffusion of the segregated elements, maraging steel ingots are soaked at the hot-working temperature (ref. 87). The time varies with the ingot size and the grade of steel; the temperature range generally used is 2200° to 2300° F. As an example, a period of 3 hours at 2300° F has been used (ref. 88). Homogenizing temperatures are well above those at which most of the secondary phases and precipitates dissolve, but safely below the solidus temperature.

Ingot breakdown may be accomplished by hot rolling, by press or hammer forging, or by a combination of forging and rolling (ref. 83). The usual products are slabs, blooms, and billets. Plate and other flat-rolled products often are produced by rolling directly from the ingot stage.

To further the homogeneity of the material, it is desirable, where practicable, to upset as well as to draw forge. In the manufacture of plate and other flat-rolled products, it is desirable to schedule some cross-rolling in the operation, rather than to produce the product entirely by straightaway rolling. Cross-rolling tends to improve the degree of correspondence between the mechanical properties in the transverse and in the longitudinal directions.

The maraging steels exhibit no hot shortness in the hot-working temperature range and may be worked from about 2300° F down to temperatures somewhat below 1500° F without cracking (ref. 87). One schedule that has been used to forge ingots of the 18 Ni 200, 18 Ni 250, and 18 Ni 300 grades into billets is as follows (ref. 84):

- (1) Preheat to 1200° F.
- (2) Heat to 2250° F and soak.
- (3) Forge until the metal has cooled to 1700° to 1900° F.

- (4) Reheat as needed to 2200° to 2250° F.
- (5) Finish forging at 1700° to 1900° F.
- (6) Air-cool.

Before hot working, the surfaces of ingots are commonly conditioned by grinding. Care is taken in the grinding to avoid smearing and dragging of metal along the surface, rather than clean removal of it, because the resulting condition carries through to the finished hot-rolled product and sometimes to finished cold-rolled products, causing surface and subsurface defects.

CONVERSION OF SLABS, BLOOMS, AND BILLETS

The conversion of ingot-breakdown products is accomplished almost entirely by hot rolling. In this manner, slabs are converted to plate or strip; blooms are processed into large-sized forging stock, large rounds, and other massive shapes; and billets are processed into bar shapes, tubing, rod, wire, and sheet bar for further conversion to sheet. Before reheating, the ingot-breakdown product is inspected, and surface defects are removed by grinding or other suitable means.

Rolling is done in the same temperature range as that used for ingot breakdown, the material usually being air cooled to room temperature after the last pass. The general practice is to schedule operations in such a way that considerable reduction is done at the lower end of the temperature range during the final hot-working cycle. The fine grain size resulting from finishing at low temperatures with a fairly heavy reduction increases the strength and toughness of the steel. Superior results have been reported when hot working is finished below 1700° F, and preferably at about 1500° F (ref. 89). The only other way to change the grain size of the maraging steels is by cold working and then annealing.

When the final hot-working temperature is high, i.e., 2000° F and above, the manner in which the work is cooled to room temperature influences the toughness of the material. The 18 Ni 250-grade maraging steel, for example, has been severely em-

brittled when slow cooled through, or isothermally held in, the temperature range of 1400° to 1800° F after being heated above 2000° F (refs. 90 and 91). The degree of embrittlement was found to increase as the upper temperature was increased above 2000° F, as the holding temperature was increased toward 1800° F, and as the time at the holding temperature was extended (ref. 92). The source of the embrittlement was considered to be the precipitation of minute platelets of titanium carbonitride along the austenite grain boundaries occurring at intermediate temperatures (ref. 92). The effect may well have been augmented by grain coarsening occurring during heating at the upper temperature. In any event, the observations indicate that work finished hot should be cooled to room temperature quite rapidly and without interruption.

The results of another investigation point to the desirability of water-spray quenching after the last pass in the manufacture of maraging steel plate (ref. 93). In this investigation, ½-inch-thick plates of 18 Ni 250-grade maraging steel were produced by finishing at temperatures of 1600°, 1750°, and 1980° F, the amount of reduction in the last pass in each case being about 35 percent. Three plates were finished at each temperature; one being air cooled, another cooled in vermiculite, and the third water-spray quenched.

Finishing temperature had little effect on the strength of the material when aged. However, at a specific finishing temperature, the slow-cooled material tended to show slightly lower strength and ductility than the other materials. The effects of slow cooling were more evident in material aged directly after hot rolling than in material that had been annealed before being aged.

In fracture toughness, however, the results were considerably different, as may be seen in figure 43 which shows the plane-strain fracture-toughness index, K_{Ic} , at a yield strength of 250 ksi for the material in the various conditions studied. It can

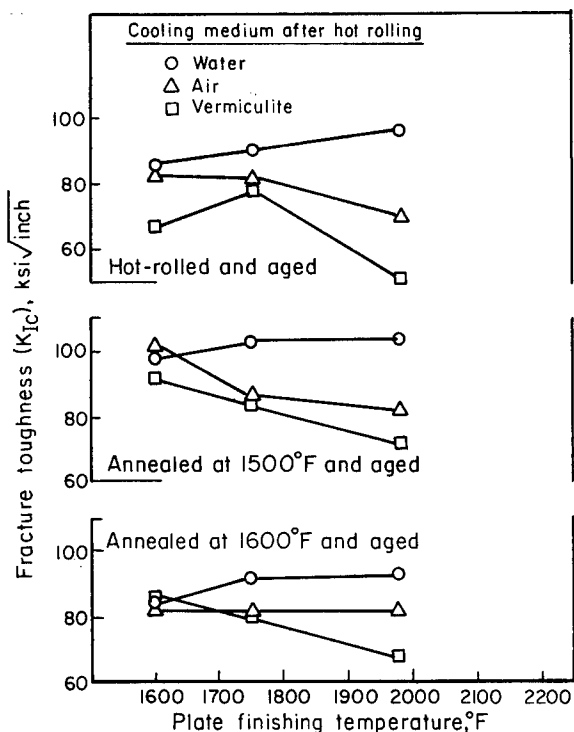

FIGURE 43.—Effect of finishing temperature on the fracture toughness of 18 Ni 250-grade maraging steel at a yield strength of 250 ksi (ref. 93).

be seen that the effects of the rolling variables were similar for material tested as aged, and as annealed and aged, after hot rolling. In general, as finishing temperature increased, K_{Ic} values decreased (increasing brittleness) for plates cooled in air or vermiculite, but increased for water-spray-quenched plates. In addition, at any particular finishing temperature, K_{Ic} decreased as the cooling rate decreased, the effect being more pronounced at the higher finishing temperatures than at the lower ones.

Austenite grain size was not a factor with respect to either strength or toughness because the grain size of all the materials was essentially the same, approximately ASTM No. 7. However, electron-metallographic examination of extraction replicas showed that the fracture path in the brittle samples was along prior austenite grain boundaries and that these boundaries contained large amounts of titanium carbonitride precipitate.

The results clearly showed the desirability of rapidly cooling plate, as by spray quenching, from any finishing temperature, the need for rapid cooling being greater the higher the finishing temperature. If spray quenching is not feasible and the metal must be air cooled, then a low finishing temperature with substantial reduction at that temperature is desirable.

Finally, it should be said that hot forming operations can be carried out subsequently on the mill product without danger of embrittlement if the reheating temperature does not exceed 1950° F. Yet, there is some possibility of restoring embrittled material by reheating to 2000° F and above, followed by rapid cooling. However, because the treatment invites rapid grain growth, it may only be partially successful and therefore should be used only as a last resort.

ANNEALING

Many maraging-steel-mill products are supplied to the customer in the mill-annealed condition. Plate, sheet, and strip are normally supplied in this condition. The usual practice is to heat the product thoroughly at 1500° F and air-cool.

Recently, it was found that the reproducibility of mechanical properties is improved and a superior combination of strength and toughness is obtained with a double-annealing cycle (ref. 94). The conditions that have been used are heating to 1600° to 1800° F, followed by air cooling to room temperature, reheating to 1400° to 1500° F, and again air cooling. A typical cycle is to heat 1 hour at 1750° F, air-cool, reheat 1 hour at 1450° F, and air-cool.

The mechanism by which the double-annealing treatment improves mechanical properties is not well understood. Apparently, the first anneal carried out at the higher temperature insures that the material will be completely recrystallized, a condition that may not always occur when the steel is given a single anneal at lower temperatures.

QUALITY CONTROL

It is axiomatic that high-performance materials, such as the maraging steels, be

produced to stringent specifications designed to define the quality of the material with precision and to insure that it performs adequately in service. To manufacture mill products from high-performance materials, the producer must have a quality-control program integrated with his production operations that assures the manufacture of products which do, in fact, meet specifications.

The quality-control program in the mill is usually a three-step operation. The first step is the qualification of raw materials. In the case of maraging steels, the materials of major concern are the melting stock, fluxes, deoxidants, furnace refractories, ladle refractories, and ladle nozzles that are used in air melting in the electric-arc furnace. These materials are analyzed to determine their chemical composition, the objective being to insure that the composition of the heat will be within specifications and that harmful contaminants will not be introduced. Consumable-electrode, vacuum-arc remelting involves no additional material; however, in vacuum-induction remelting, the furnace, ladle linings, and nozzles again are of concern.

The second step is in-process inspection, the objectives of which are to identify conditions at the proper time that may prevent the finished product from meeting specifications and to insure that the required remedial action is taken at the appropriate stage of mill processing. An important concern of this operation is the identification of surface defects in material at various intermediate stages of processing. Hand in hand with this activity is the parallel function of assuring the removal of the defects. It is common to inspect the surfaces of vacuum-arc remelted ingots as well as ingots from air melts before forging or rolling; of blooms before conversion to billets and slabs; of slabs before rolling to plates; and of billets before conversion to bar stock, rod, and other mill products.

Ingots may contain cold shuts, cracks, and roughness due to irregularities in the mold wall. The surfaces of blooms, slabs and billets may contain rolled-in scale, laps, seams, slivers, and cracks. Surface defects may be removed by lathe turning, milling, chipping, and grinding.

Another activity in the in-process inspection category is the examination of vacuum-arc remelted ingots for grain structure, presence of precipitates, and degree of segregation. This is done by removing a transverse slice from one end of the ingot and examining the surface visually or at low magnification after it has been macroetched. Still another function is determination of the forgeability of the steel. This can be accomplished by upsetting or step forging a series of specimens with a press or hammer. Yet another activity is the monitoring of in-process annealing treatments to insure that they have effected the desired degree of softness and the desired grain size in the metal. Other functions relate to the control of such factors as weights, dimensions, flatness, and straightness, as the material moves through the mill on the way to becoming a finished mill product.

The third step is the quality assurance operation. Here, the finished or nearly finished product is inspected to determine that it does meet specifications and to assure the purchaser that such is the case. The tests that are made in each case are determined by the requirements of the applicable specification. They may include such items as grain-size determination; Rockwell or Brinell hardness; room-temperature tensile properties for the material as annealed and aged; nonmetallic inclusion rating; and indications of surface and internal defects. The methods used to inspect for surface and internal flaws include ultrasonic testing, radiographic inspection, liquid-penetrant inspection, and magnetic-particle inspection. Comments on these methods appear in chapter 2.

CHAPTER 5

Fabrication

This chapter covers the types of fabricating methods normally encountered in the production of end items from 18-percent nickel maraging steel-mill products. Included are cutting, shearing, grinding, hot working, the more common cold-working processes, warm working, mechanical machining procedures, welding, heat treating, and descaling and pickling. The less commonly used fabricating processes such as explosive forming, electrospark discharge machining, electrochemical machining, electrolytic grinding, soldering, and brazing are not discussed. In many cases, these fabricating methods are most appropriate in unusual situations and, in other cases, the principles guiding the procedures are not well developed; thus, the parameters must be determined on a trial-and-error basis to suit each new situation. Perhaps the best way to obtain literature on these subjects is to make a NASA STAR search or a Defense Documentation Center search.

CUTTING, SHEARING, AND GRINDING

The 18-percent nickel maraging steels are sawed in the hot-worked or annealed conditions. High-speed-steel circular saws with alternating high- and low-tooth design, the high teeth being set 1/32 inch above the low teeth, have been used with success (ref. 95). For cutting with a circular saw, it has been recommended that a speed of 60 to 70 surface feet per minute be used with a feed of 0.001 to 0.002 inch per tooth, the coolant being either chlorinated sulfurized fatty mineral or sperm oil, or a rich

solution of soluble oil in water (15 parts water to 1 part oil) (ref. 96).

The 18-percent nickel maraging steels can be cut by thermal methods, the oxyacetylene torch being widely used and the plasma-arc process being recommended because of its efficient heat input (ref. 96). Delamination of hot-rolled plate and cracking of hot-rolled billets have been encountered occasionally in oxyacetylene cutting (ref. 97). However, the difficulty has been overcome by cutting while the metal is still hot or by heating to 1100° F and cooling to room temperature before cutting (ref. 98). At the same time, the severity of laminations has been reduced greatly with improvements in procedures for converting ingots to plate, as indicated in chapter 4.

It is reasonable to postulate that hot-rolled or annealed 18-percent nickel maraging steels can be sheared in much the same manner as the extra-high-strength, quenched-and-tempered structural steels with yield strengths in the vicinity of 110 ksi. The latter can be sheared in thicknesses to about 1 inch, although punching can be done in plate to thicknesses of perhaps one-half inch (ref. 99). Sturdy, amply powered equipment with sharp, properly set blades and secure clamping are required. In shearing hot-rolled or annealed maraging steel, as well as maraging steel cold worked 50 percent, it has been reported that the capacity of the equipment should be 1½ times that required for mild steel of the same thickness (ref. 100).

As to grinding, the indications are that

the 18-percent nickel maraging steels behave in a manner similar to that of stainless steels. They can be ground easily when using a heavy-duty, water-soluble grinding fluid such as is employed with stainless steels (ref. 100). When ordinary water-soluble oil is used, excessive wheel wear may be encountered. Aluminum oxide, vitrified bonded wheels of medium hardness and medium-to-open structure have been satisfactory (ref. 98). Additional information on grinding is given in table 7.

HOT WORKING

The 18-percent nickel maraging steels can be hot worked to finished or semifinished products by all the standard methods that are used for other steels. The principal processes are forging, hot forming, and extrusion.

To avoid the possibility of carburizing or sulfidizing, the metal should be free of oil, grease, and shop soil before heating. Likewise, fuel low in sulfur is preferred. It has been recommended that fuel oil equal to Grade 3 and containing not more than 0.75 percent sulfur or fuel gas containing not more than 100 grains of total sulfur per 100 cubic feet be used (refs. 98 and 100). It has also been suggested that the furnace atmosphere contain about 5 CO₂ (ref. 98). Such an atmosphere would neither carburize nor cause excessive scaling of the steel.

Forging

The 18-percent nickel maraging steels can be forged into a broad spectrum of shapes, varying widely in size and complexity. The metal can be press or hammer forged at temperatures of 2300° F down to 1500° F or slightly below (ref. 100), although one reference suggests stopping at 1600° F (ref. 98). It has been recommended that large sections of the metal be preheated at intermediate temperatures, such as 1700° to 1800° F, before being raised to the forging temperature; bar stock and billets having cross sections less than 6 inches square do not require preheating (ref. 98). Heating times comparable to those used for low-alloy steels may also be employed; i.e., about 15 minutes per inch of section.

Forging is completed at comparatively low temperatures, usually 1500° to 1700° F, with considerable reduction in thickness at those temperatures (refs. 100, 101, and 102). The objective is to refine the grain structure, thereby enhancing the strength and toughness of the steel. For optimum mechanical properties in the finished product, a minimum of 25 percent reduction in thickness during the final forging cycle has been recommended (ref. 102).

The practice of finish forging at relatively low temperatures places an added burden on the forging equipment. Power requirements, loads on dies, and the frequency with

TABLE 7.—Data on the Grinding of 18 Percent Nickel Maraging Steels

[From ref. 98]

Condition of material	Hardness of material, Rockwell C	Wheel speed, fpm	Table speed, fpm	Downfeed, in./pass	Crossfeed, in./pass
Hot rolled, as rolled ----- and Hot rolled, annealed -----	30-33	5500 to 6500	50 to 100	Rough 0.003 Finish 0.001	¼-wheel width
Maraged -----	50-60	5500 to 6500	50 to 100	Rough 0.003 Finish 0.0005	¼-wheel width

TABLE 8.—*Mechanical Properties of Rear Domes for Pershing Rocket-Motor Cases*^a

[From ref. 101]

Aging temperature, F	Yield strength, psi		Tensile strength, psi		Elongation, percent		Reduction in area, percent	
	Min	Max	Min	Max	Min	Max	Min	Max
850° -----	251 900	269 200	269 200	271 300	10.0	12.0	39.8	48.7
900° -----	271 300	278 600	284 500	289 200	8.0	12.0	36.0	48.2
950° -----	279 400	287 600	286 600	293 900	8.0	10.0	37.6	48.7

^a Radial and tangential specimens taken from center, midradius, and skirt, then solution treated at 1500° F for 1 hr, air cooled, and aged 3 hr at indicated temperatures.

which tools must be rebuilt, all are increased.

It appears that tooling designed for low-alloy steel often may be used with success for the maraging steels (ref. 101). However, for optimum properties in the finished part, the die design should be tailored specifically to the characteristics of the maraging steels. For example, regions receiving only small reductions during the final forging operation show lower transverse ductility and Charpy-impact values than those that are well worked during finish forging (refs. 100 and 101). Therefore, the sets of dies that are used should be so designed that all regions of the product are well worked in the final forging operation.

The experience of one forging company producing domes from 18 Ni 250-grade maraging steel for Pershing rocket-motor cases illustrates the consistency of mechanical properties obtainable with good forging practice (ref. 101). Shown in table 8 are the results of tension tests made on radial and tangential specimens taken at the center, midradius, and skirt locations on the rear domes. The specimens were annealed 1 hour at 1500° F, air-cooled, and aged 3 hours at either 850°, 900° or 950° F before testing. As the table shows, the differences in tensile properties among locations or directions in the dome, within any group of specimens aged at the same temperature, are very small.

The results of an evaluation carried out on rolled ring forgings produced from the

18 Ni 250 grade of maraging steel illustrate some other aspects of forging procedure (ref. 97). In this program, eight ring forgings were made of air-melted and vacuum-degassed steel and eight forgings were made of consumable-electrode, vacuum-arc remelted steel. The starting stock was either a 10-inch round-cornered square 13½ inches long or a 12-inch round-cornered square 16⅞ inches long. In the production of the rings, two heating temperatures were used for upsetting, 2250° and 1950° F; two heating temperatures were used for rolling, 2250° and 1950° F; and two wall thickness reductions were employed, 50 and 75 percent. When the starting temperature for rolling was 2250° F, the operation was carried to completion without reheating. However, when the heating temperature for rolling was 1950° F, the workpiece was reheated several times to this temperature in the course of the rolling operation. The production schedules are given in table 9.

Standard ¼-inch-diameter tension-test specimens, as well as bars for precracked Charpy V-notch impact tests, were removed from each ring in the axial, circumferential, and radial direction. The specimens were annealed at either 1500° or 1650° F before being aged 3 hours at 900° F. Statistical analysis of the test results indicated that the vacuum-arc remelted steel had greater strength and fracture toughness than the air-melted material; that material annealed at 1500° F was stronger than that annealed

TABLE 9.—*Rolled Ring Forgings Used in Evaluation Program*

[From ref. 97]

Material -----	Air-melt or vacuum-arc remelt							
	75				50			
Percent wall reduction ----								
Upsetting temperature, F ..	1950°		2250°		1950°		2250°	
Rolling temperature, F ----	1950°	2250°	1950°	2250°	1950°	2250°	1950°	2250°

Production of Rings With 50 Percent Wall Reduction
Stock: 10-inch round-cornered square 13-1/2 inches long

Procedure:

- (1) Upset to 6-inch height and plug 5-inch diameter hole
- (2) Ring roll and flatten to 12-inch I.D. by 6-inch wall by 4-inch height
- (3) Ring roll and flatten while rolling to 3-inch wall by 4-inch height

Production of Rings With 75 Percent Wall Reduction
Stock: 12-inch round-cornered square 16-7/16 inches long

Procedure:

- (1) Upset to 4-inch height and plug 5-inch diameter hole
- (2) Ring roll and flatten to 1-1/2-inch I.D. by 10-1/2-inch wall by 4-inch height
- (3) Ring roll and flatten while rolling to 2-7/8-inch wall by 4-inch height

at 1650° F; and that circumferential specimens showed the greatest ductility and fracture toughness.

The statistical analysis of the forging variables indicated that upsetting temperature had no significant effect on strength, ductility, or fracture toughness. However, ring-rolling practice influenced fracture toughness. As shown in figure 44, rolling from 2250° F without reheating resulted in a median circumferential fracture toughness W/A value of 490 in.-lb/in.² compared with a median value of 415 in.-lb/in.² for rolling from 1950° F with repeated reheatings. Thus, ring rolling from 2250° F without reheating seems to be the preferable practice.

The degree of plastic deformation in the final ring-rolling operation exerted a pronounced influence on fracture toughness, but not on strength. The cumulative frequency distribution curves in figure 45 show that increasing final wall reduction from 50 to 75 percent increased the median W/A value in the circumferential direction by about 180 in.-lb/in.². Although the difference at the median for the axial and the radial directions was less, the data clear-

ly demonstrated the beneficial effect of a substantial final hot reduction.

Hot Forming

Perhaps the most common hot-forming operation is bending, although hot spinning and hot drawing are also done with considerable frequency. For optimum mechanical properties in the finished product, it is desirable to use minimum temperatures (ref. 102). A suggested range is 1800° to 1500° F (ref. 98). Higher temperatures can be used, but, as mentioned in chapter 4, fast cooling becomes increasingly important the higher the temperature, if high levels of fracture toughness are to be maintained. In particular, it is not desirable to carry out forming operations at temperatures above 1950° F because rapid grain growth may occur and, unless the cooling rate is quite fast, the material may become embrittled.

Extrusion

Although maraging steel tubular products are made by extrusion, and it has been reported that the extrusion process has been used in the production of preforms for

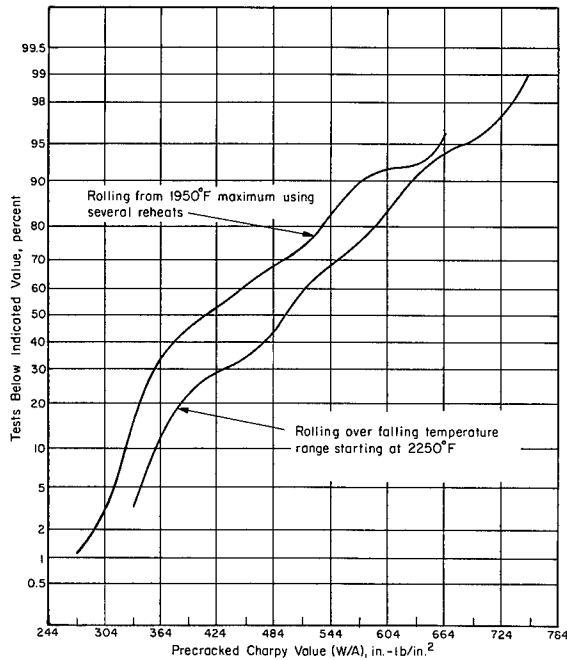

FIGURE 44.—Cumulative-frequency distribution curves showing the effect of ring-rolling practice on the fracture toughness of 18 Ni 250-grade maraging steel rings (ref. 97).

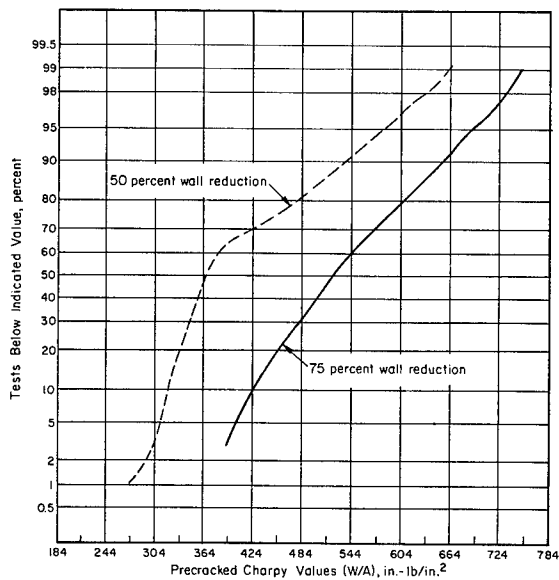

FIGURE 45.—Cumulative-frequency distribution curves showing the effect of final-wall reduction on the fracture toughness of 18 Ni 250-grade maraging steel rings (ref. 97).

shear forming (ref. 103), little detailed information on the extrusion of the 18-percent nickel maraging steels has appeared in the literature.

An investigation concerned with the production of 0.060-inch-thick tee sections 1 inch by 2 inches by 20 feet long demonstrated the capability of these steels to be extruded in thin sections (ref. 104). The extrusion ratio was 45 to 1; the die material was a cobalt-base alloy containing nominally 33.5 percent Cr, 6.0 percent W, and 1.0 percent C; the die was coated with zirconium oxide; the program was carried out on an H. M. Harper 1200-ton press; and the billet heating atmosphere was dry nitrogen. In an extensive series of trials, it was found that thoroughly satisfactory extrusions with excellent dimensional accuracy and surface finish could be produced when the billet heating temperature was $2075 \pm 25^\circ \text{F}$, the transfer time was 16 seconds, the container temperature was 600° to 700°F , the lubricant was a glass, and the ram pressure was approximately 3000 psi, resulting in an average ram speed of 2.2 ips.

COLD FORMING

Almost invariably, cold-forming operations are performed on annealed material. The combination of enormous strength and reduced ductility makes it possible to carry out only the simplest operations, such as bending with very generous radii, on the metal in the age-hardened condition. However, even in the annealed condition, the 18-percent nickel maraging steels have yield strengths in the order of 115 ksi, approximately four times that of deep drawing steel body stock, a clear indication that forming equipment must be sturdy, rigid, and well powered. As a first approximation, power requirements can be considered proportional to yield strength.

Aside from its yield strength, another factor that profoundly influences the cold-forming characteristics of a metal is its ductility and, particularly, the manner in which the ductility is displayed. Being martensitic, these steels exhibit limited

tensile elongation. In fact, the tensile elongation of annealed sheet may be as little as 3 to 4 percent (ref. 105). In addition, the amount of uniform elongation in tension tests is small and necking down sets in rapidly. These facts indicate some limitations with respect to the firing of sheet metal by processes in which the stresses are predominantly tensile.

Yet, as mentioned in chapter 3, the 18-percent nickel maraging steels work harden very slowly and can be reduced substantial amounts by a number of methods; i.e., up to 85 percent or more reduction in section, before annealing is required (ref. 100). The modest influence of cold rolling on the hardness of annealed 18 Ni 250-grade maraging steel, as illustrated in figure 36, attests to the fact that these steels have great capacity for certain kinds of cold working.

A good way to characterize cold-forming capability is to examine the plastic anisotropy ratio (R value) of the material. The R value shows whether the material tends to thin in the thickness direction, when stretched, or tends to draw in along the width direction. The expression for the R value is as follows:

$$R = \frac{\log_e \left(\frac{W_o}{W_f} \right)}{\log_e \left(\frac{T_o}{T_f} \right)}$$

W_o = original width
 W_f = final width
 T_o = original thickness
 T_f = final thickness

The measurements required to determine R values are made from tension tests. These measurements are not easy to make at best and are extremely difficult when the material shows only a small amount of uniform elongation before necking down. Nevertheless, the R value for the maraging steels seems to lie between 0.6 and 1.0 (ref. 105). By comparison, the R value for deep drawing mild steel is between 1.2 and 1.5. The R value for the maraging steel shows that the material tends to thin in the thickness direction during tensile deformation

and, therefore, the metal can be expected to have limited capabilities in such sheet-forming processes as deep drawing and stretch forming.

However, a low R value is advantageous where the process depends on thinning of the material. Operations that make use of thinning are rolling, wire drawing, and shear forming. The performance of the 18-percent nickel maraging steels in important cold-forming processes is described in the following sections.

Shear Forming

In this process, which also is known by such other names as flow turning, flow forming, and shear spinning, a flat circular blank, a ring, or a thick-walled cylindrical preform is cold worked over a mandrel by force exerted by a narrow small-diameter roller. Two basic types of shear forming are illustrated in figures 46 and 47. By the process shown in figure 46, the wall thickness of a tubular or ring-shaped preform is reduced and the length correspondingly extended. No drastic change in shape occurs. The preform usually is machined from a forging billet, although work is in progress on the fabrication of preforms by rolling and welding plate (ref. 102). The latter method would constitute far more efficient utilization of material.

In the setup shown in figure 47, a flat blank is changed to a conical or curved shape. The resulting thickness is controlled by the original thickness of the blank and the geometry of the mandrel as illustrated in figure 48.

In shear forming the maraging steels, high-carbon, high-chromium alloy tool steel hardened to 550 to 600 BHN, or ductile iron or alloy gray iron hardened to at least 400 BHN, are recommended mandrel materials (ref. 100). Roller tool profile rings have been made of molybdenum- and tungsten-high-speed steels, as well as chromium-hot-work tool steel, hardened to 58 to 62 Rockwell C. Steels suggested for this

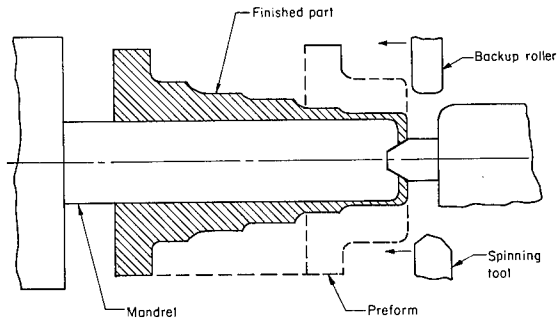

FIGURE 46.—Setup for testing the shear-forming capability of 18 percent nickel maraging steel (ref. 106).

application are types M4, T5, and H11. The bodies on which the profile rings are mounted have been made of shock-resisting tool steel hardened to 60 Rockwell C.

To prevent galling and seizing between the work and the mandrel, a heavy paste lubricant such as a lithium soap or colloidal zinc has been applied to the inside surface of the workpiece and to the mandrel (ref. 106). Because considerable heat is generated in the work and the tool during shear forming, a steady flow of coolant, as near room temperature as feasible, must be directed at the work and the tool. Soluble oil and water, 20 parts water to one part oil, or medium-to-rich solutions of a chemically active water-soluble coolant, have been used with success (ref. 106). Coolants should be continually filtered. Lubricants and coolants should be completely removed from the work before annealing or other heat treatment.

Spindle speeds at 350 to 1000 fpm, with roller tool feeds of 0.010 to 0.100 inch per revolution, have been used to work cylindrical preforms; speeds of 600 to 1000 fpm and feeds of 0.020 to 0.080 inch per revolution have been used to shape cones from flat blanks (ref. 100). For each job, the optimum combination of speed and feed is determined by trial. The principal factors are the fluidity of the metal, the diameter of the part, the thickness and strength of the wall of the part, and the surface finish desired. It has been recommended that a speed of 600 fpm and a feed of 0.040 inch per revolu-

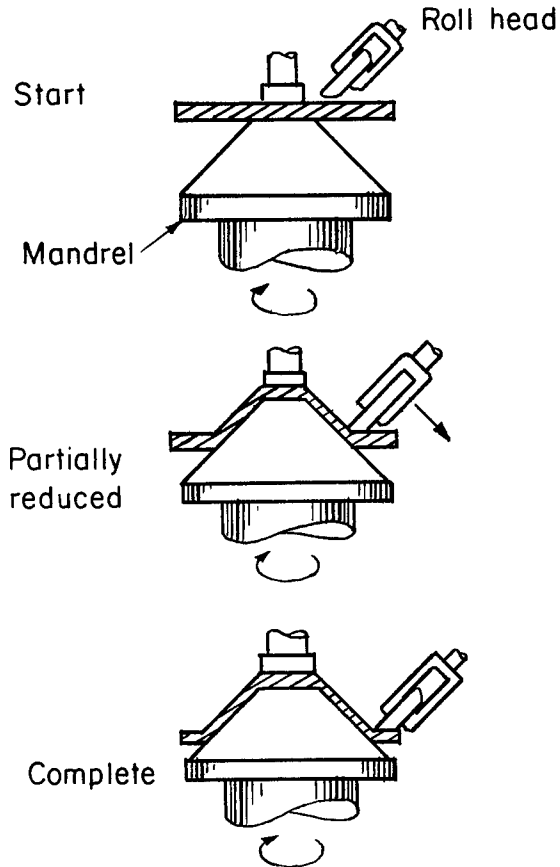

FIGURE 47.—Setup for shear forming a conical shape from a flat blank (ref. 107).

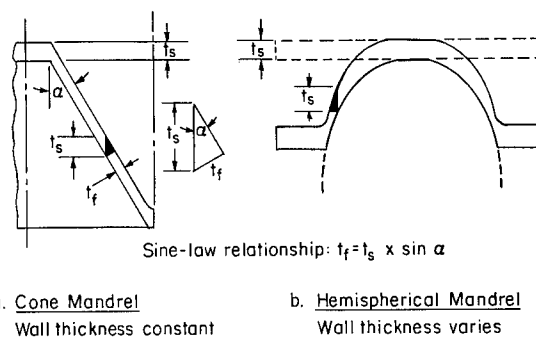

FIGURE 48.—Sketches showing the relationship between wall thickness and mandrel angle (ref. 107).

tion be taken as a point of departure (ref. 106). Trials can be expedited by taking into account the principles that high speed and low feed produce the smoothest finish;

a low feed will cause diameter growth and loosen the work from the mandrel, and a high feed will tighten the work on the mandrel; a high speed may impair the rigidity of the setup and may also cause overheating; and a high feed with thin-walled material may develop enough working pressure to fracture the part.

The results of experimentation have suggested a rule-of-thumb guide to feasible wall thickness reductions (ref. 106). In shaping cones, 50 percent reduction in one operation has been satisfactory.

In shear forming ring shapes and cylindrical preforms up to $\frac{5}{16}$ inch in thickness, a 6-to-1 reduction ration (83 percent) in one pass is possible, provided the resulting wall thickness is not less than 0.030 inch. For material over $\frac{5}{16}$ inch thick, excessively large reductions should be avoided; although the metal may not rupture, it may pile up ahead of the tool and interfere with the spinning operation. For the thicker materials it has been recommended that the reduction per pass be limited to 75 percent; and, of course, the work must be annealed between passes. For material with wall thicknesses between 0.030 and 0.010 inch, a maximum per pass reduction of 40 percent has been recommended, and 20 to 30 percent for thin walls.

Profiles of roller tools used to form cylindrical preforms of 18-percent nickel maraging steels are shown in figure 49 (ref. 106). Profiles of tools to form cones are

illustrated in figure 50. The peripheral radius for the contour of cone-shaping tools used on material less than $\frac{3}{16}$ -inch-thick ranges from $\frac{1}{16}$ to $\frac{1}{4}$ inch. Relief from the radius on the face of the tool should be 30° . Larger radii to $\frac{1}{2}$ inch, with zero to 10° relief, have been suggested for material thicker than $\frac{3}{16}$ inch. The contour surface of all roller tools must be polished smooth and free from cutting-tool scratches or grinding wheel marks.

Spinning

As shown in figure 51, the setup for spinning has much in common with that used in shear forming. However, the process requires much less sophisticated and, hence, less expensive equipment, but much more craftsmanship (ref. 107). Spinning may be classified as manual or power, depending on the source of the power used to form the workpiece. Power spinning makes use of hydraulic or mechanical devices that apply greater tool forces and, therefore, can be used to form thicker and stronger materials. Power spinning is recommended for the maraging steels because they are too strong to permit much manual spinning (ref. 105).

Spinning differs considerably in principle from shear forming in that the workpiece is subjected primarily to bending forces along the axis of spinning rather than to shearing forces (ref. 107). Tangential compressive forces build up during the

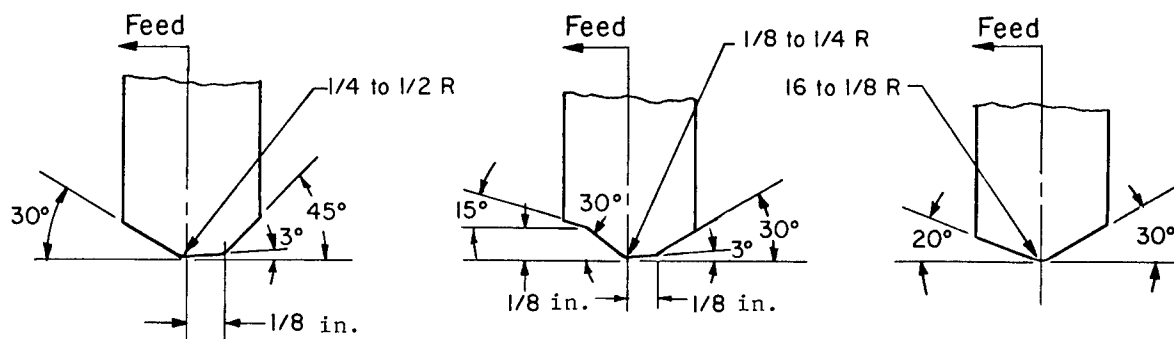

FIGURE 49.—Roller tool profiles for spinning of maraging steels. Two profiles at left are used for forming materials over $\frac{1}{4}$ inch thick. Profile at right is best for materials less than $\frac{1}{4}$ inch thick (ref. 106).

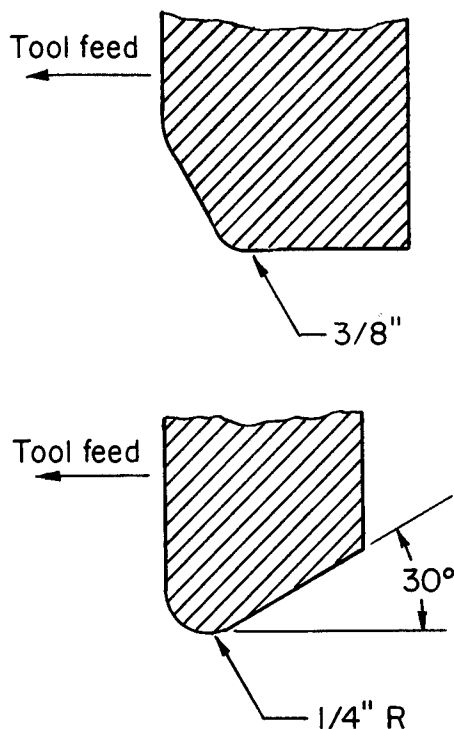

FIGURE 50.—Shear-forming tools for cold-forming maraging steels. These tools are suitable for materials under $\frac{3}{16}$ inch thick (ref. 106).

operation and, as the outer diameter decreases, the metal actually thickens and upsets slightly. This upsetting action may be troublesome so that it may lead to buckling when the ratio of the depths of the spun part to the original thickness is too great.

Spinning is useful in producing items of cylindrical or more-or-less spherical shape that have axial symmetry. The process is especially attractive for producing partial closures and reentrant contours. The starting material is a flat circular blank. However, it is common today to start with a deep-drawn shape using the spinning process to modify its contour (ref. 107).

Considerable success has been achieved in spinning the maraging steels. It has been found that they are particularly amenable to spinning when in the austenitic rather than the martensitic condition (ref. 105). The schedule used has been to austenitize the steel by annealing at some

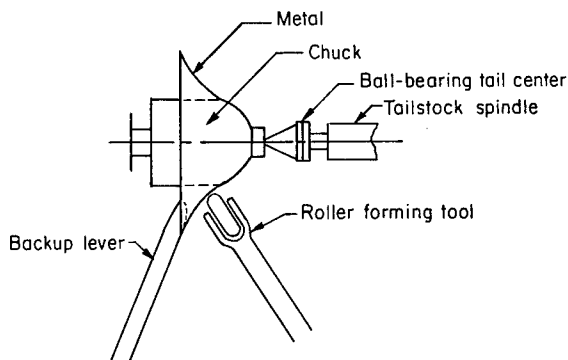

FIGURE 51.—Schematic diagram of metal spinning setup (ref. 107).

1500° F and then to spin when it has cooled, to about 400° F, at which temperature it is still austenitic and very ductile. The surface oxidation that develops is removed by pickling or shot blasting.

Deep Drawing

Flat-bottomed cups of 18 percent nickel maraging steel can be drawn cold to considerable depths in one operation; however, drawing a rounded shape, such as a hemisphere, is reported to be a difficult operation because secondary wrinkling occurs around the unsupported area of the blank between the contact point of the punch and the die-entry radius (ref. 105). The latter type of shape is more readily formed by means of the flexible-die-forming process.

Cold-rolled material in the annealed condition is recommended for deep drawing (ref. 106). The safe maximum reduction in diameter, in a single-draw operation, from the diameter of the blank to that of the drawn shell is reported as 35 percent. In subsequent draws the reduction in diameter may be 20 to 25 percent. The shell should be annealed and descaled between draws.

When the wall of the drawn part is not thinned intentionally, the clearance between the punch and die should be sufficient to permit an unrestricted flow of metal. Thus, using material up to $\frac{3}{16}$ inch thick, a clearance of 20 percent, plus metal thickness, between the punch and die (on one side)

is satisfactory (ref. 106). For heavier material, clearance between punch and die (on one side) is increased to metal thickness plus 50 percent.

Draw-ring radii should be 6 to 10 times the thickness of the blank (ref. 106). A sharp punch-nose radius causes excessive thinning, especially on the initial draw. This radius should be 5 to 8 times the thickness of the stock. The general practice of using a larger radius on the first draw and proportionately decreasing it for each succeeding draw is recommended. If reduction in diameter is 5 percent, the wall can be "ironed" about 20 percent. If the reduction in diameter is 15 percent, the wall can be ironed only about 10 percent.

The drawing speeds are approximately 30 to 40 fpm. The lower speeds, on the order of 20 fpm, should be used for ironing the walls of shells. It appears that approximately 40 percent more pressure is required for drawing the 18-percent nickel alloy in the annealed condition than for annealed AISI type 302 stainless steel.

Suitable die materials are alloy tool steel such as high-carbon, high-chromium die steel, ductile iron, and alloy cast iron. Hard aluminum bronze is reported to serve well for draw rings (ref. 106). Cemented carbide also has been suggested for draw rings, since it affords the best nongalling characteristics. Die components of high-speed tool steel are hardened and double tempered to a hardness of about 60 R. Those made of ductile iron or alloy cast iron are heat treated and flame hardened to at least 400 BHN.

Extreme-pressure lubricants containing sulfurized or chlorinated fatty mineral oils are suitable for deep drawing operations. Pigmented lubricants also are good. Solid film compounds are satisfactory and are especially useful for heavy drawing and ironing operations.

Flexible Die Forming

One of the more attractive methods for producing thin-walled maraging steel shapes by a pressing operation is the flexible die

process in which a punch forces the sheet blank into a rubber diaphragm which is pressurized on the other side by a hydraulic fluid.

Cold-rolled, solution-annealed material is preferred. Hot-rolled, solution-annealed and descaled material, with the surface free of mechanical defects, has also performed satisfactorily; however, the reduction from blank diameter should be approximately 10 percent less than is normally used for cold-rolled and annealed material (ref. 106).

In a single operation, the reduction from the blank diameter to the diameter of the drawn part should not exceed 5.0 percent for cold-rolled, annealed material (ref. 106). Parts that are to be further cold reduced should be annealed and descaled before forming is resumed. For parts made in one or more passes, the total reduction in diameter between anneals should be limited to 25 percent.

A minimum punch radius of five times the blank thickness is reported to be satisfactory for a 50-percent initial reduction in diameter from the blank diameter (ref. 106). For subsequent forming, a minimum punch radius of four times the metal thickness is usually satisfactory.

The blankholder (draw-ring) radius should be of sufficient size to avoid locally overstressing the material when it is locked to the punch. A radius of three times the blank thickness has been suggested (ref. 106).

Alloy die steel, hard aluminum bronze, cast nodular ductile iron, and alloy cast iron are suitable punch and blankholder materials. Die components of alloy die steel are hardened and double tempered to a hardness of about R. 63. Ductile iron and alloy cast iron are thermally treated and flame hardened to at least 400 BHN.

Lanolin-base greases and soft neutral potassium soap are generally used for work lubricants.

Bending and Roll Forming

Annealed material can be bent to a radius of six to eight times its thickness through

180°. These limitations are suitable for material to about $\frac{3}{8}$ -inch thickness. A minimum radius of eight times the metal thickness is suggested for heavier material (ref. 100). For press brake 90° V-die bending, a V-opening of 15 to 17 times the metal thickness, and a minimum bend radius 6 to $6\frac{1}{2}$ times the metal thickness have been recommended.

Rolling and welding of sheet, strip, and plate is a common method of forming cylindrical shapes. In the usual procedure, a cylindrical section is fabricated by joining one or more rolled elements with longitudinal seam welds. Sections so fabricated can then be joined together by means of girth welds to produce cylinders of increased length. The cylindrical components of large rocket-motor cases have been formed from 18 percent nickel maraging steel plate by this procedure; the largest size thus far produced is 260 inches in diameter and made from 0.73-inch-thick plate (ref. 108).

Another method of roll forming a cylindrical shape is illustrated in figure 52. The metal, in the form of strip, is wrapped at an angle over a mandrel, producing a helix, each turn abutting the previous turn. The metal is welded along the helical line of contact during or following wrapping. This process has been used to form the cylindrical sections of 20-inch-diameter motor cases from 0.040-inch-thick 20 percent nickel maraging steel strip (ref. 109). There is every reason to consider the 18-percent nickel maraging steels equally adaptable to this forming technique.

WARM WORKING

From time to time, situations may be encountered in which more plasticity than is available in the metal at room temperature would be advantageous, but fabrication at standard hot working temperatures is inappropriate. In these cases, resort may be had to warm working; that is, working at intermediate temperatures where the metal displays greater ductility than at room temperature. The 18-percent nickel maraging steels can be warm worked in two ways.

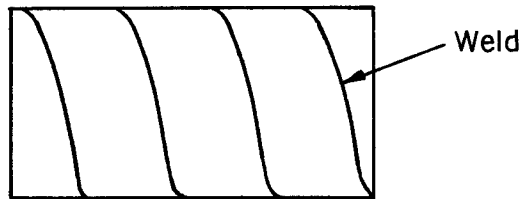

FIGURE 52.—Sketch of helically wrapped cylinder.

The annealed metal, which is in the martensitic condition, can be worked advantageously at temperatures substantially above ambient (ref. 98). However, in establishing the fabrication parameters attention must be paid to the amount of heat generated by the operation itself. The initial heat content of the workpiece together with the additional heat input from the forming operation must not be so great as to raise the temperature of the metal above 600° to 650° F. Somewhat above these temperatures, noticeable age hardening occurs and tends to defeat the purpose of warm working by increasing the metal's resistance to deformation and reducing its ductility.

The 18-percent nickel maraging steels also can be warm worked in the austenitic condition (ref. 110). The procedure is to austenitize the metal by heating to the annealing temperature and then air cooling to the working temperature. The metal will remain austenitic as long as its temperature does not fall below the M_s temperature; i.e., some 310° F. By this method, hemispherical shapes have been successfully spun from flat 18 percent nickel maraging steel blanks (ref. 105).

Two sizes of cylindrical hydroburst test specimens were shear formed successfully from preforms in the austenitic condition (ref. 103). One size was 4.25 inches inside diameter by 0.050 inch wall by 7 inches long, and the other was 14.5 inches inside diameter by 0.072 inch wall by 30 inches long. The preferred fabrication schedule was to austenitize the preform at 1500° F, air-cool to 500° F, and effect a 65-percent wall reduction in two passes, the feed and speed being so adjusted that the temperature of

the work increased no more than 100° F during the forming operation. High strength was obtained on subsequent aging 3 hours at 900° F. The process was deemed to be a technically attractive and economical way to produce cylindrical sections for rocket-motor cases.

MACHINING

The machining characteristics of the 18-percent nickel maraging steels have been the subject of a number of investigations. One program comprised an extensive series of turning tests on 6-inch-diameter by 30-inch-long workpieces of annealed 18 Ni 300-grade maraging steel in which AISI 4340 heat treated to the same hardness as the maraging steel, i.e., 30–32 Rockwell C, was included for purposes of comparison (ref. 111). Tool force tests were run using a semiorthogonal condition; i.e., a 0° side cutting edge angle. The triangular carbide inserts that were used had side rake angles of +5°, 0°, and -5°. Tool life tests were made to compare the machinability of the maraging steel and AISI 4340, to evaluate the effect of side rake angle, and to obtain information on the type of cemented carbide best suited for machining the maraging steel. The side cutting edge angle was 15°. The same rake angles were used as were employed in the tool force tests, but with 3/4-inch-square inserts, rather than triangular inserts. The end-point criterion for the tool life tests was a 0.015-inch flank wear scar on the clearance face.

It was concluded that the 18 Ni 300-grade maraging steel is readily machinable in the annealed condition. Although the life of tools having negative side rake angles was slightly shorter with the maraging steel than with AISI 4340, it was suggested that inserts with negative rakes may be the more economical and preferred tooling for most normal machining operations. The net power required to machine the maraging steel was slightly less than for AISI 4340; however, the difference was not so great as to justify use of less powerful machine tools. In fact, it was recommended that the

same considerations given to the selection of machine tools for machining low-alloy high-strength steels also be given to equipment destined for machining maraging steels. Carbide tool grades C-7 and C-8 were satisfactory for machining the maraging steel. The compositions of tool materials used to machine the maraging steels are given in table 10 (ref. 112). The major difference noted in machining the annealed 18 Ni 300 grade of maraging steel, as compared with the AISI 4340 material, was the difficulty encountered in chip breaking.

The rough analogy between annealed 18 percent nickel maraging steel and AISI 4340 heat treated to the same hardness is a good first approximation. However, as is true of all materials, the process must be adapted to the material if optimum results are to be obtained. Considerable effort has been directed toward determining the specific parameters in the machining of the 18 percent nickel maraging steels, and recommended procedures have been developed for all the major machining processes.

Annealed 18 Ni 250-Grade Maraging Steel

In turning annealed 18 Ni 250-grade maraging steel, cutting speed has been found to exert a profound influence on tool life, as shown in figure 53 (ref. 113). For example, at a cutting speed of 90 fpm with an M2 high-speed steel tool, the tool life was 86 minutes. An increase of 10 percent in the cutting speed decreased the tool life to 12 minutes. The cutting speed with carbide tools was five times that with the M2 high-speed steel tools for a given tool life. The tool life was 40 minutes at a cutting speed of 480 fpm using a C-3 grade of carbide and slightly less with the C-6 carbide grade. It is to be noted also in figure 53 that, for a tool life of 30 minutes, the cutting speed on the maraging steel with a C-6 grade of carbide was 50 percent higher than on AISI 4340 stock heat treated to the same hardness.

Cutting speed also is critical in face milling, particularly with high-speed steel cutters (ref. 113). As shown in figure 54,

TABLE 10.—Tool Materials Used to Machine 18 Percent Nickel Maraging Steels

[From ref. 112]

Designation	C	Cr	V	W	Mo	Co	WC	TiC	TaC
High-Speed Steel									
M1 -----	0.80	3.75	1.15	1.75	8.75	-----	-----	-----	-----
M2, class 1 -----	.85	4.00	2.00	6.25	5.00	-----	-----	-----	-----
M3, class 2 -----	1.20	4.00	3.00	6.25	5.75	-----	-----	-----	-----
M7 -----	-----	-----	-----	-----	-----	-----	-----	-----	-----
M10 -----	-----	-----	-----	-----	-----	-----	-----	-----	-----
M33 -----	.88	3.75	1.15	1.75	9.50	8.25	-----	-----	-----
M34 -----	.90	3.75	2.10	1.75	8.75	8.25	-----	-----	-----
M35 -----	.85	4.00	2.00	6.00	5.00	5.00	-----	-----	-----
M44 -----	1.15	4.25	2.00	5.25	6.50	11.75	-----	-----	-----
T15 -----	1.55	4.50	5.00	12.50	.60	5.00	-----	-----	-----
M41 -----	-----	-----	-----	-----	-----	-----	-----	-----	-----
Sintered Carbide									
C-2 -----	-----	-----	-----	-----	-----	9	91	-----	-----
C-3 -----	-----	-----	-----	-----	-----	4.5	95.5	-----	-----
C-6 -----	-----	-----	-----	-----	-----	10	82	8	-----
C-7 -----	-----	-----	-----	-----	-----	8	80	12	-----
C-8 -----	-----	-----	-----	-----	-----	6	84	10	-----
C-50 -----	-----	-----	-----	-----	-----	8.5	72	8	11.5

increasing the cutting speed from 155 fpm to 190 fpm resulted in decreasing the cutter life from 208 to 24 inches of work travel (ref. 113). On the other hand, cutter life was not so sensitive to cutting speed when carbide tools were used. However, it is to be noted that when face milling dry, the life of the cutter was almost double that when using a soluble oil. It is possible that cutter life was reduced when the coolant was used by the occurrence of chipping brought about when the coolant quenches the cutter as it leaves the cut. It should also be noted that positive rake angles were used. The axial rake was $+10^\circ$ and the radial rake was 0° . These tool angles provided an appreciably longer tool life than negative rake angles.

In the same investigation, end-mill slotting of the annealed steel was not found to be particularly difficult (ref. 113). The effect of feed on tool life at a cutting speed of 177 fpm is illustrated in figure 55. The

life of the $\frac{3}{4}$ -in.-diameter end mill did not decrease rapidly until the feed exceeded 0.003 inch per tooth. Figure 56 shows the effect of cutting speed on tool life at a feed of 0.002 inch per revolution. At a cutting speed of 140 fpm, for example, the tool life was 200 inches of work travel.

The annealed 18-percent nickel maraging steel also was observed to perform well in drilling and tapping operations (ref. 113). Using a conventional $\frac{1}{4}$ -in.-diameter-screw machine drill, 135 holes could be drilled at a feed of 0.005 ipr and a cutting speed of 100 fpm. In tapping a $\frac{5}{16}$ -24 NF thread in a $\frac{1}{2}$ -inch-deep through hole, the tap life was 180 holes at a cutting speed of 150 fpm.

The performance of the annealed maraging steel in drilling, in comparison with AISI 4340 and D6AC, is shown in table 11 (ref. 113). It is seen that, under the same drilling conditions, the maraging steel could be drilled three times as fast as the AISI 4340 material of comparable hardness.

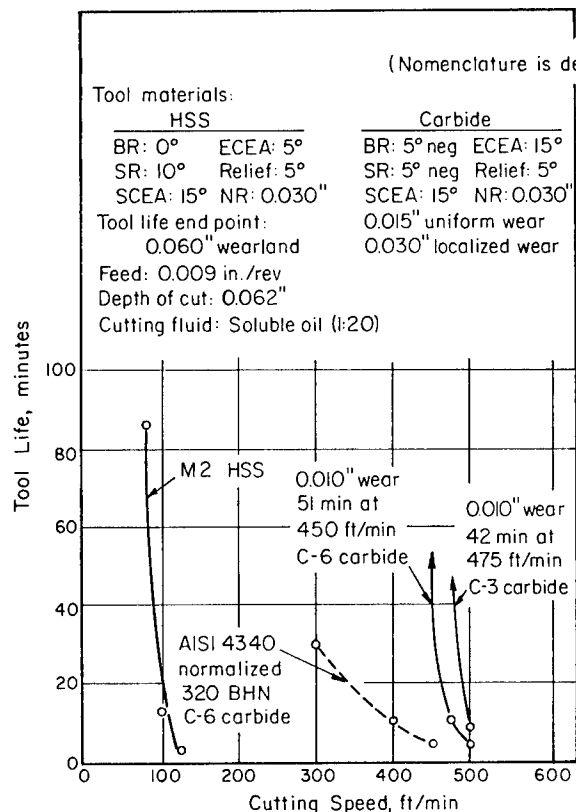

FIGURE 53.—Effect of cutting speed and tool material on tool life in turning annealed 18 Ni 250-grade maraging steel (ref. 113).

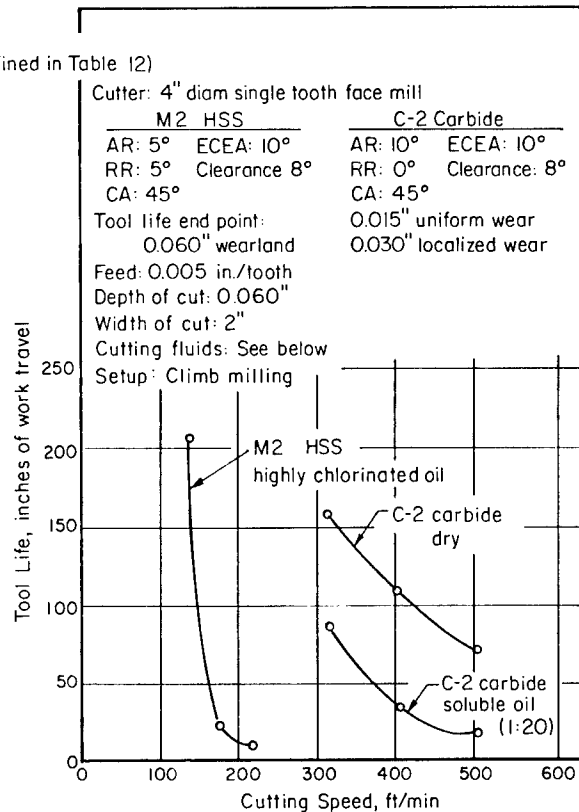

FIGURE 54.—Effect of cutting speed and tool material on tool life in face milling annealed 18 Ni 250-grade maraging steel (ref. 113).

TABLE 11.—Data on the Drilling of 3 Steels

[From ref. 113]

Conditions: Drill: 1/4-inch diameter M1 high-speed steel screw machine length
 Feed: 0.005 inch/rev
 Depth: 0.5 inch through
 Cutting fluid: Highly sulfurized oil

Steel	Condition	Hardness, BHN	Cutting speed, ft/min	Tool life, holes
AISI 4340	Annealed	217	125	250
AISI 4340	Normalized	341	30	140
D6AC	Annealed	229	90	175
18 Ni 250 grade	Annealed	321	100	140

The outcome of the investigation was the establishment of recommended practices for the machining of the maraging steels. Recommendations for annealed 18 Ni 250-grade maraging steel are given in table 12.

Recommendations offered by another source are given in tables 13, 14, 15, and 16 (refs. 96 and 100). The latter recommendations are intended to apply to the 18 Ni 200 and 18 Ni 300 grades as well as to the 18 Ni 250

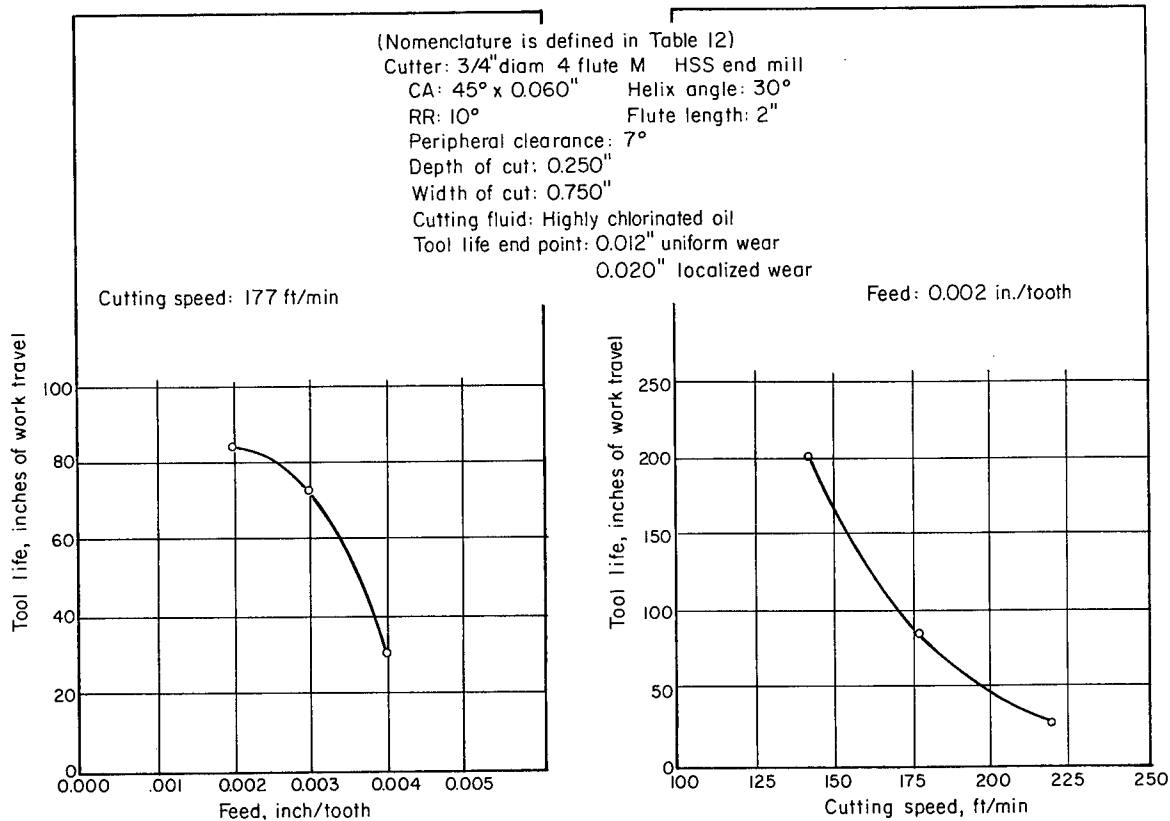

FIGURE 55.—Effect of feed rate on tool life in end-mill slotting of annealed 18 Ni 250-grade maraging steel (ref. 113).

FIGURE 56.—Effect of cutting speed on tool life in end-mill slotting of annealed 18 Ni 250-grade maraging steel (ref. 113).

grade of maraging steel. Close scrutiny shows that the data from the various sources are in generally good agreement.

Age-Hardened 18 Ni 250-Grade Maraging Steel

Because the maraging steels must sometimes be machined after aging, the machining characteristics of these steels in the age-hardened condition have been brought under study. As aged, the 18 Ni 250 grade has a hardness in the order of 50–53 Rockwell C.

The importance of the tool material in turning the aged steel is shown in figure 57 (ref. 113). At a cutting speed of 60 fpm, the life of the T15 high-speed steel was 90 minutes, whereas that of the M2 steel was only 10 minutes. As was the case with the annealed maraging steel, the cemented carbides considerably outperformed the high-

speed steels. However, there was an appreciable difference between the two grades of carbide that were studied. As shown in figure 57, the cutting speed for a 30-minute tool life with C-6 carbide was 150 fpm compared to 280 fpm with G-3 carbide.

An interesting comparison is made in figure 57 between the results obtained with the C-6 grade of carbide in turning the maraging steel, aged to 52–53 R_c, and those obtained on an AISI 4340 steel, quenched and tempered to 52 R_c. The data indicate that under the same conditions the maraging steel can be machined at almost twice the cutting speed for a 30-minute tool life as can the AISI 4340 steel.

The T15 grade of high-speed steel was found to be superior to the M2 high-speed steel in face milling the aged maraging steel. As shown in figure 58, the cutting

TABLE 12.—Recommended Conditions for Machining 18 Ni (250) Maraging Steel in the Annealed Condition

[From ref. 113]

Operation	Tool material	Tool geometry	Tool used for tests	Depth of cut, inches	Width of cut, inches	Feed	Cutting speed, ft/min	Tool life	Wear-land, inches	Cutting fluid
Turning	M2 HSS	BR: 0°; SCEA: 15° SR: 10°; ECEA: 5° Relief: 5° NR: 0.030 in.	5/8-inch-square tool bit.	0.060		0.009 in./rev.	80	85 min	0.060	Soluble oil 1:20.
Turning	C-3 Carbide	BR: -5°; SCEA: 15° SR: -5°; ECEA: 15° Relief: 5° NR: 0.030 in.	1/2-inch-square throwaway insert.	0.060		0.009 in./rev.	475	40 min	0.010	Soluble oil 1:20.
Face milling	M2 HSS	AR: 0.030 in. AR: 5°; ECEA: 10° RR: 5° CA: 45°	4-inch-diameter single-tooth face mill.	0.060	2	0.005 in./tooth	140	200-in. work travel	0.060	Highly chlorinated oil.
Face milling	C-2 Carbide	Clearance: 8° AR: 10°; ECEA: 10° RR: 0° CA: 45°	4-inch-diameter single-tooth face mill.	0.060	2	0.005 in./tooth	330	150-in. work travel	0.015	Dry.
Side milling	C-2 Carbide	Clearance: 8° AR: 5°; ECEA: 10° RR: 5° CA: 45°	4-inch-diameter single-tooth face mill.	0.100	1	0.005 in./tooth	670	175-in. work travel	0.015	Dry.
Peripheral end milling.	M2 HSS	Clearance: 8° Helix angle: 30° RR: 10° Clearance: 7° CA: 45° x 0.060 in.	3/4-inch-diameter 4-tooth HSS end mill.	0.250	0.750	0.004 in./tooth	225	150-in. work travel	0.012	Soluble oil 1:20.
End mill slotting.	M2 HSS	Helix angle: 30° RR: 10° Clearance: 7° CA: 45° x 0.060 in.	3/4-inch-diameter 4-tooth HSS end mill.	0.250	0.750	0.002 in./tooth	140	200-in. work travel	0.012	Highly chlorinated oil.
Drilling	M1 HSS	Clearance: 7° CA: 45° x 0.060 in. 118° plain point Clearance: 7°	1/4-inch-diameter HSS drill	0.500 through	—	0.005 in./rev.	85	300 holes	0.006	Highly chlorinated oil.
Reaming	M2 HSS	Helix angle: 0° CA: 45° Clearance: 7°	2-1/2-inches long. 0.272-inch-diameter 6-flute chucking reamer.	0.500 through	—	0.009 in./rev.	60	170 holes	0.006	Highly sulfurized oil.
Tapping	M1 HSS	Clearance: 7° 2-flute plug 75 percent thread	5/16-24 NF tap	0.500 through	—	—	150	175 holes	Under-size threads	Highly sulfurized oil.

Nomenclature: HSS=high-speed steel; BR=back rake; SR=side rake; SCEA=side cutting edge angle; ECEA=end cutting edge angle; NR=nose radius; AR=axial rake; RR=radial rake; CA=corner angle; NF=national fine.

TABLE 13.—*Machining Procedures for Annealed or Hot-Worked 18 Percent Nickel Maraging Steels*^a

[From refs. 96 and 100]

Turning	Tool materials ^b -----	High-speed steel types T-15, M-3 type 2, M-15, and M-34. Cemented carbide types C-2, C-50, C-70
	Speed, sfpm -----	50-95 (HSS), 220-400 (CC type C-50)
	Feed, ipr -----	0.01-0.018
	Depth, inches -----	0.1-0.4
	Coolants ^c -----	Nos. 1, 2, and 3
Planing	Tool materials ^b -----	High-speed steel types T-15, M-2, M-35
	Speed, fpm -----	40-50
	Feed, inches -----	0.015 (roughing), to 3/16 (finishing), to 0.008 (parting)
	Depth of cut, inches -----	3/16 (roughing), 0.010 (finishing)
Milling	Coolants ^c -----	Nos. 1 and 2 (1 only for finishing)
	Tool materials ^b -----	High-speed steel types T-15 and M-3 type 2 Cemented carbide types C-50 (face milling) and C-2 (slotting and end milling)
	Speed of cutter, sfpm -----	HSS: 60-70 (plain); 60-80 (face); 50-80 (slotting and end), CC: 275-325 (face); 175-250 (slotting and end)
	Feed per cutter tooth, inches -----	HSS: 0.002-0.004 (plain); 0.003-0.004 (face); 0.001-0.003 (slotting and end), CC: 0.005-0.008 (face); 0.001-0.004 (slotting and end)
	Coolants ^c -----	Nos. 1, 2, and 3
Drilling	Tool materials ^b -----	High-speed steel types T-15, M-2, and M-33
	Speed, fpm -----	60-85
	Feed, ipr -----	1/8-inch drill: 0.0015; 1/4-inch drill: 0.0025; 1/2-inch drill: 0.006; 3/4-inch drill: 0.011; 1-inch drill: 0.012
Reaming	Coolants ^c -----	Nos. 1, 2, and 3 (reduce speed as hole becomes deeper)
	Tool materials ^b -----	Tungsten or molybdenum high-speed steels surface treated to improve wear resistance. Cemented carbide: type C-50
	Speed, sfpm -----	40-55 (HSS), 70-110 (CC)
	Feed, ipm -----	1 to 1-1/2 times that of drill size corresponding to reamer size
Tapping	Coolant ^c -----	No. 1
	Tool materials ^b -----	High-speed steels
	Speed, sfpm -----	15
	Thread tappable, percent of full depth. -----	70-75
	Coolant ^c -----	No. 1

^a HSS=high-speed steel; CC=cemented carbide.^b For compositions, see table 10.^c Coolants:

1. Chlorinated, sulfurized fatty mineral and/or sperm oil
2. Rich solution of soluble oil in water
3. Chemically active water soluble oil

speed with the T15 high-speed steel cutter was at least 15 percent higher than that with the M2 high-speed steel cutter for equivalent tool life. Also, with the carbide cutter, negative rake angles were found to be far superior to positive ones in face milling the aged steel.

The effect of feed on tool life in end-mill slotting is illustrated in figure 59 (ref. 113). Cutter life was multiplied by three when

the feed was decreased from 0.002 inch per tooth to 0.001 inch per tooth. As shown in figure 60, cutting speed also is a critical factor in end-mill slotting the hardened maraging steel.

The selection of the tool material and tool geometry was found to be very important in the drilling of the 18 Ni 250-grade maraging steel after age hardening to high-hardness levels (ref. 113). Drill life with

TABLE 14.—*Tool Geometries for Machining Annealed or Hot-Worked 18 Percent Nickel Maraging Steels*^a

[From ref. 100]

Turning:

High-speed steels:

BR: 0° to 5°; SCEA: 15° to 20°; SR: 10° to 15°; ECEA: 5° to 7°, Relief: 5° to 7°; NR: 1/32 inch, chip breaker required.

Cemented carbides:

Precision ground throwaway inserts with BR: -5° and SR: -5°. For light finish cuts, +5° BR and SR are satisfactory. Square or rectangular inserts are preferred. A chip breaker is required; mechanical attached breakers are preferred.

Planing:

High-speed steels:

Roughing: BR: 8°, lip grind face of cutting edge to 30° hook, lead angle: 35°; SR: 3°, end relief: 5°; NR: 1/16 inch, or BR: 8°; SR: 20°, lead angle: 35°; SR: 4°, end relief: 7°; NR: 3/32 inch.

Finishing:

BR: 8°, cutting edge inclined at an angle of 12° to 15° with line of travel of the work, end relief: 5°.

Parting:

Grind face to 25° hook, axial side clearance: 6°; SR: 4°, end relief: 12°, break corners.

Gooseneck tools are suggested. Clapper boxes with return stroke lifting devices are recommended.

Plain milling:

High-speed steels:

RR: 8° to 12°, clearance angle of 4° is sufficient for cutters over 3 inches in diameter, somewhat greater clearance is required for smaller cutters, helix angle: 25° to 40°.

Face milling:

High-speed steels:

AR: 5° to 8°; RR: 5° to 8°; CA: 45°, face cutting edge angle: not over 4°, face relief: 4° to 6°, peripheral relief: 4° to 6°.

Cemented carbides:

AR: 0° to -7°; RR: -10°; CA: 45°, face cutting edge angle: not over 4°, face relief: 4° to 6°, peripheral relief: 4° to 6°.

End milling:

High-speed steels:

Helix angle: 25° to 35°; RR: 8° to 10°, face cutting edge angle: 3° to 4°; CA: 45°, face relief: 5°, peripheral relief: 4° to 5°.

Cemented carbides:

Helix angle: 25° to 35°; RR: 0°, face cutting edge angle: 3°; CA: 45°, face relief: 4°, peripheral relief: 4° to 5°.

Slotting:

High-speed steels:

RR: 5°, side reliefs: 3° to 5°, peripheral clearance: 4° to 5°.

Cemented carbides:

RR: 0°, side reliefs: 3° to 5°, peripheral clearance: 3° to 4°.

Drill grinds:

High-speed steels:

118°-120° included point angle. Thin the web of the drill at the chisel point 40 to 50 percent of its original thickness, 120°-135° chisel edge angle, 9°-12° lip clearance.

^a Nomenclature is defined in table 12.

T15 high-speed steel was more than double that obtained with M1 high-speed steel drills. Also, an additional 50 percent increase in cutting speed resulted by using a split point instead of a plain-point drill.

In the age-hardened condition, the 18 Ni 250 grade of maraging steel was observed to have better characteristics in drilling and in tapping than AISI 4340 quenched and tempered to the same hardness (ref. 113).

TABLE 15.—Data on Reamer Geometry ^a

[From ref. 100]

End cutting, straight fluted reamers are preferred for reaming straight, noninterrupted holes.

End cutting, spiral fluted reamers with the hand of spiral opposite to the hand of cut are satisfactory for reaming interrupted cuts.

Spiral fluted reamers with the hand of spiral opposite to the hand of cut are suggested for reaming tapered holes.

Suggested Geometry for HSS and Carbide End-Cutting Straight and Spiral Fluted Reamers ^b

Radial ^c rake angle, degrees	Chamfer		Circular margin		Land	
	Angle, degrees	Relief, ^d degrees	Reamer diameter, in.	Width, in.	Reamer diameter, in.	Relief, degrees
0 to 5 -----	45	20 to 10	to ½	0.004 to 0.010	to ½	20 to 10
		10 to 8	½ to 1	0.010 to 0.015	½ to 1	10 to 8
		8 to 6	1½ to 2	0.015 to 0.020	1½ to 2	8 to 6

^a Tungsten or molybdenum high-speed steels surface treated to improve wear resistance. C-50 cemented carbide is recommended.

^b Manufacturers' standard back taper.

^c Use 0° with cemented carbide and spiral fluted reamers.

^d Secondary relief equals primary relief plus 15° to 6°.

TABLE 16.—Data on Taps for Machine or Hand Tapping Annealed or Hot-Worked 18 Percent Nickel Maraging Steels

[From ref. 100]

Spiral pointed taps are preferred for machine tapping through holes.

Conventional chamfered plug taps are satisfactory for tapping bottoming holes.

Serial hand taps are likewise satisfactory.

Interrupted thread taps are satisfactory.

Suggested Tap Geometries ^a

Rake angle, degrees	Chamfer ^b angle, degrees	Chamfer relief angle, degrees	Land relief	Spiral point angle, degrees
6 to 8 -----	10 to 12	4 to 6	Concentric ^c	12 to 20

^a Manufacturers' standard back taper.

^b Proportion chamfer angle and number of flutes so the chip load per tooth is not more than 0.004 in. on hot-worked and annealed materials and 0.0015 to 0.002 in. on maraged material.

^c Concentric taps are suitable to 3/8-inch diameter.

Data are given in tables 17 and 18. In drilling, it was found that for the same tool life the maraging steel could be drilled almost twice as fast and at double the feed. In tapping, the cutting speed was 20 percent higher and the tool life three times longer.

Recommended conditions for machining the 18 Ni 250 grade of maraging steel in

the age-hardened condition are listed in tables 19, 20, 21, and 22. The recommendations given in tables 20, 21, and 22 apply to the 18 Ni 200 and to the 18 Ni 300 grades of maraging steel. The information on reaming shown in table 15 also applies to age-hardened 18 percent nickel maraging steels, except that class C-2 or C-70 cemented carbide is recommended instead of C-50.

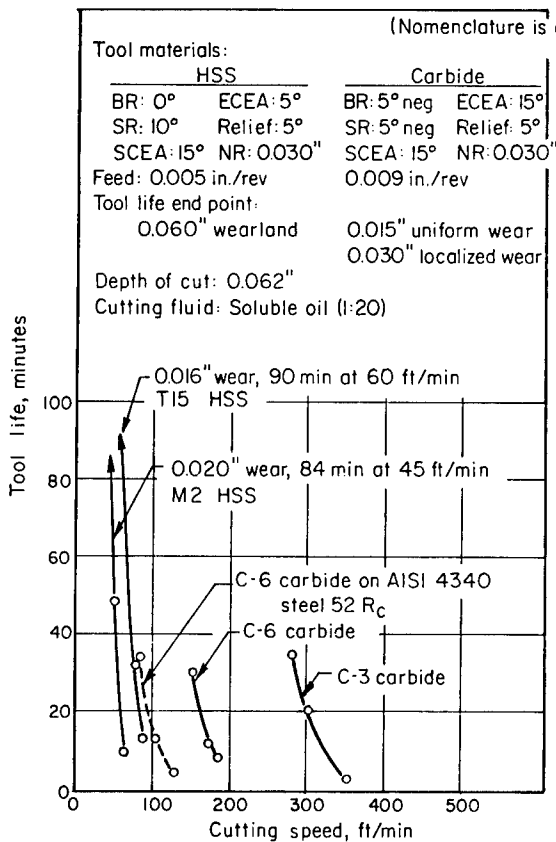

FIGURE 57.—Effect of cutting speed and tool material on tool life in turning fully aged 18 Ni 250-grade maraging steel (ref. 113).

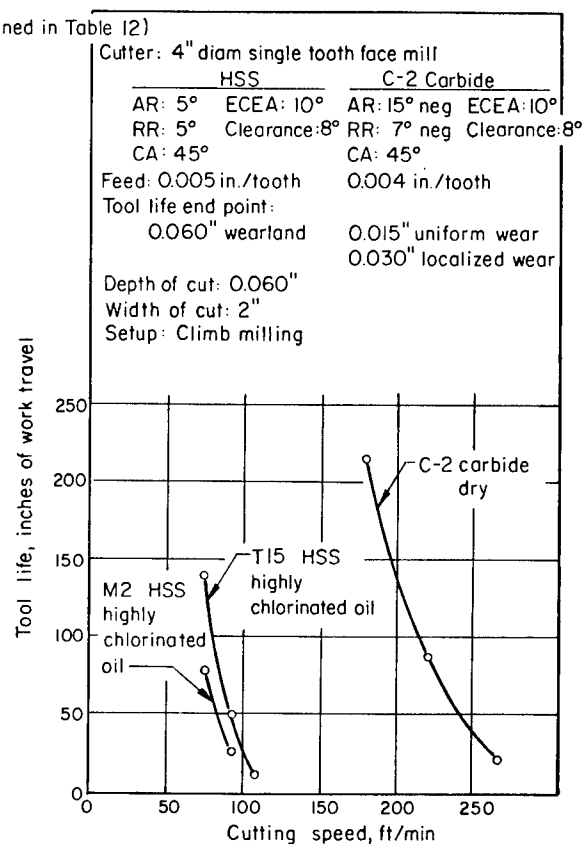

FIGURE 58.—Effect of cutting speed and tool material on tool life in face milling fully aged 18 Ni 250-grade maraging steel (ref. 113).

Annealed 18 Ni 300-Grade Maraging Steel

Generally no distinction is made between the machining characteristics of the 18 Ni 250 and the 18 Ni 300 grades of maraging steel (refs. 96, 98, and 100). However, in one study minor differences were noted (ref. 114).

In this study, it was found that T15 high-speed steel was a definitely preferable tool material for turning the 300-grade steel, whereas M2 or M3 were entirely satisfactory for the 250 grade (ref. 114). Compare figures 53 and 61. It was found also that the C-6 and C-8 grade cemented carbides outperformed the C-2 and C-3 grades on the 18 Ni 300-grade material; however, in turning the 18 Ni 250-grade steel, the C-3 was superior to C-6.

In drilling tests on the annealed 18 Ni 300-grade steel, it was found that, for a tool life of 200 holes, the use of a highly sulfurized cutting oil permitted a 20-percent increase in cutting speed over that obtained when a highly-chlorinated oil was used (ref. 114). The speeds were 90 fpm versus 75 fpm. Tool life was strongly influenced by feed, falling off quite rapidly when the feed was increased much above 0.005 ipr.

In reaming, the highly sulfurized and highly chlorinated cutting oils were found to be far superior to soluble oil, the sulfurized oil being somewhat better than the chlorinated fluid (ref. 114). The highly sulfurized oil also was more effective than the highly chlorinated oil in tapping annealed 18 Ni 300-grade maraging steel.

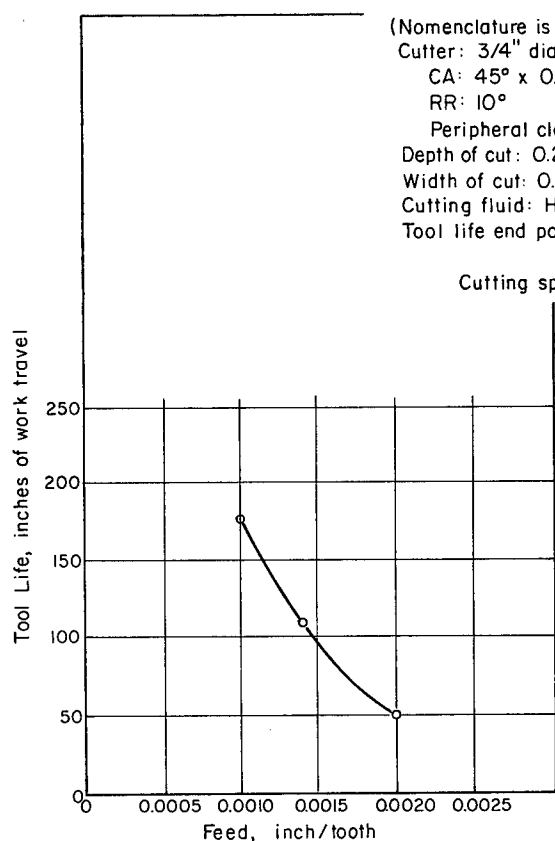

FIGURE 59.—Effect of feed on tool life in end mill slotting of fully aged 18 Ni 250-grade maraging steel (ref. 113).

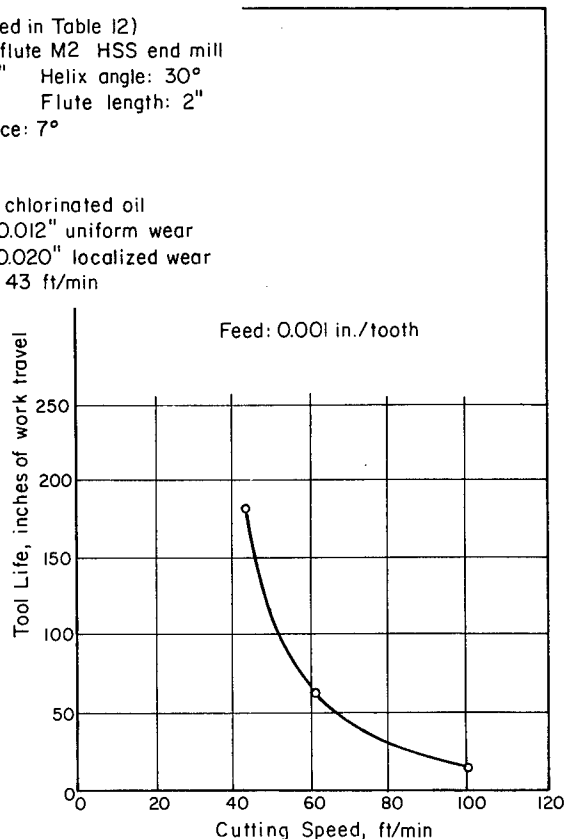

FIGURE 60.—Effect of cutting speed on tool life in end-mill slotting of fully aged 18 Ni 250-grade maraging steel (ref. 113).

Recommended conditions for machining this material are given in table 23. Additional data on the machining of annealed 18 Ni 300-grade maraging steel are shown in table 24 (ref. 115).

Age-Hardened 18 Ni 300-Grade Maraging Steel

Age-hardened 18 Ni 300-grade maraging steel is slightly more difficult to machine than age-hardened 18 Ni 250-grade maraging steel because it is somewhat harder. The difference is manifested principally in slower cutting speeds and shorter tool life, as is evident on comparing tables 10 and 25. The latter table gives recommended practices for machining 18 Ni 300-grade maraging steel in the age-hardened condition.

WELDING

A satisfactory process for welding the 18-percent nickel maraging steels usually must produce a joint with the same, or nearly the same, ultra-high-strength and superior fracture toughness in the age-hardened condition that is processed by the base metal. This is a tall order. Of particular importance among the factors that influence these properties are the microstructure of the weld metal and the heat-affected zone, the composition of the weld, and the heat-input heat-dissipation relationships.

Weld Deposit Microstructure

The photomicrographs in figure 62 show microstructures typical of 18 percent nickel maraging steel weld metal deposited by such

TABLE 17.—Data on the Drilling of 18 Ni 250-Grade Maraging Steel and AISI 4340 Both in the Hardened Condition

[From ref. 113]

Conditions: Drill: ¼-in.-diameter. T15 HSS screw machine length
 Depth: 0.500 inch through
 Cutting fluid: Highly sulfurized oil

Steel	Condition	Hardness, Rockwell C	Cutting speed, ft/min	Feed, in./rev	Tool life, holes
AISI 4340 ---	Quenched and tempered ---	50	30	0.001	100
18 Ni (250) -	Age hardened -----	50	50	.002	100

TABLE 18.—Data on the Tapping of 18 Ni 250 Maraging Steel and AISI 4340 Both in the Hardened Condition

[From ref. 113]

Conditions: Tap:

4 flute taper tap 5/16-18 NC
 M10 HSS nitrided (AISI 4340)
 2 flute plug spiral point 5/16-24 NF
 M1 HSS nitrided (maraging steel)
 Depth: 0.500 inch through

Steel	Condition	Hardness, Rockwell C	Cutting fluid	Cutting speed, ft/min	Tool life, holes
AISI 4340 ..	Quenched and tempered	50	Inhibited trichloroethane -	5	32
18 Ni 250 --	Age hardened -----	50	Highly chlorinated oil ----	7	125

methods as the gas-tungsten arc, gas-metal arc, and submerged arc processes. The microstructure of the material as aged comprises dendritic cells of light-etching martensite surrounded by boundary regions composed of dark-etching martensite with light-colored islands of austenite, which usually occur at the intersections. Electron microprobe investigation has shown both the dark-etching intercellular regions and the austenite islands to be enriched in nickel, titanium, and molybdenum, whereas the light-etching martensitic cells were depleted of these elements (ref. 116). The amount of cobalt segregation was insignificant.

It has been observed also that when fractures occur in the weld they tend to follow cell boundaries, cutting through the cells only when forced to do so by the orientation of the crack plane to the axes of the den-

drites. These tendencies are observable in figure 62. Electron-microfractographic examination of fractures in GTA¹ and SA² welds made in plate has indicated that, when the plane-strain fracture toughness value was high, most of the fracture surface was dimpled, a condition indicative of ductility; however, when the plane-strain fracture-toughness value was low, considerable portions of the surface were flat (ref. 116). Moreover, electron diffraction studies of extraction replicas of fracture surfaces showed the flat, featureless areas to contain high concentrations of titanium carbide and titanium nitride particles in contrast to the dimpled areas which contained fewer parti-

¹ GTA = gas-tungsten arc.² SA = submerged arc.

TABLE 19.—Recommended Conditions for Machining 18 Ni 250-Grade Maraging Steel in the Age-Hardened Condition^a
 [From ref. 113]

Operation	Tool material	Tool geometry	Tool used for tests	Depth of cut, inches	Width of cut, inches	Feed	Cutting speed, ft./min	Tool life	Wear-land, inches	Cutting fluid
Turning	T15 HSS	BR: 0°; SCEA: 15° SR: 10°; ECEA: 5° Relief: 5° NR: 0.030 in.	5/8-inch-square tool bit.	0.062		0.005 in./rev.	60	90 min	0.016	Soluble oil 1:20.
Turning	C-3 carbide	BR: -5°; SCEA: 15° SR: -5°; ECEA: 15° Relief: 5°	1/2-inch-square throwaway insert.	0.062		0.009 in./rev.	275	35 min	0.015	Soluble oil 1:20.
Face milling	T15 HSS	NR: 0.030 in. AR: 5°; ECEA: 10° RR: 5° CA: 45°	4-inch-diameter single-tooth face mill.	0.060	2	0.005 in./tooth	75	140-in. work travel	0.060	Highly chlorinated oil.
Face milling	C-2 carbide	Clearance: 8° AR: -15°; ECEA: 10° RR: -7° CA: 45°	4-inch-diameter single-tooth face mill.	0.060	2	0.004 in./tooth	180	210-in. work travel	0.015	Dry.
Side milling	C-2 carbide	Clearance: 8° AR: -15°; ECEA: 10° RR: -7° CA: 45°	4-inch-diameter single-tooth face mill.	0.100	1.25	0.004 in./tooth	300	80-in. work travel	0.015	Dry.
Peripheral end milling	M2 HSS	Clearance: 8° Helix angle: 30° RR: 10°	3/4-inch-diameter 4-tooth HSS end mill.	0.250	0.750	0.001 in./tooth	80	160-in. work travel	0.012	Highly chlorinated oil.
End mill slotting.	M2 HSS	CA: 45° x 0.060 in. Helix angle: 30° RR: 10°	3/4-inch-diameter 4-tooth HSS end mill.	0.250	1.0	0.001 in./tooth	40	175-in. work travel	0.012	Highly chlorinated oil.
End mill slotting	C-2 carbide	Clearance: 7° CA: 45° x 0.060 in. AR: -7°; ECEA: 45° RR: -7°; NR: 0.045 in.	1-inch-diameter 2-tooth end mill with carbide throwaway inserts.	0.125	—	0.002 in./tooth	312	160-in. work travel	0.015	Dry.
Drilling	T15 HSS	Clearance: 7° 118° split point 7° clearance angle	1/4-inch-diameter HSS drill	0.500 through	—	0.002 in./rev.	50	100 holes	0.015	Highly sulfurized oil.
Reaming	M33 HSS	Helix angle: 0° CA: 45°	2-1/2 inches long, 0.272-inch-diameter 6 flute chucking reamer.	0.500 through	—	0.005 in./rev.	100	90 holes	0.006	Highly sulfurized oil.
Tapping	M1 HSS Nitrided	Clearance: 7° 2-flute plug spiral point 75 percent thread	5/16-24 NF tap	0.500	—		7	125 holes	Under-size threads	Highly chlorinated oil.

^a Nomenclature is defined in table 12.

TABLE 20.—*Machining Procedures for Age-Hardened 18 Percent Nickel Maraging Steels*^a

[From refs. 96 and 100]

Turning	Tool materials ^b	High-speed steel types T15, M3 type 2, M15 and M34. Cemented carbide types C-2, C-50, C-70
	Speed, sfpm	30-35 (HSS), 90-115 (CC types C-2 or C-70)
	Feed, ipr	0.01
	Depth, inches	0.1
	Coolants ^c	Nos. 1, 2, and 3
Planing	Tool materials ^b	High-speed steel types T15, M2, M35
	Speed, fpm	25
	Feed, inches	0.015 (roughing) to 3/16 (finishing), to 0.004 (parting)
	Depth of cut, inches	3/16 (roughing), 0.010 (finishing)
Milling	Tool materials ^b	High-speed steel types T15 and M3 type 2. Cemented carbide types C-59 (face milling) and C-2 (slotting and end milling)
	Speed of cutter, sfpm	HSS: 15-25 (face); 15-25 (slotting and end) CC: 60-80 (face); 50-70 (slotting and end)
	Feed per cutter tooth, inches	HSS: 0.003 (face); 0.0005-0.002 (slotting and end) CC: 0.005 (face); 0.0007-0.002 (slotting and end)
	Coolants ^c	Nos. 1, 2, and 3
	Drilling	Tool materials ^b
Speed, fpm		20-25
Feed, ipr		1/8-inch drill: 0.001; 1/4-inch drill: 0.002 1/2-inch drill: 0.005; 3/4-inch drill: 0.005 1-inch drill: 0.009
Coolants ^c		Nos. 1, 2, and 3 (reduce speed as hole becomes deeper)
Reaming		Tool materials ^b
	Speed, sfpm	15-25 (HSS) 25-50 (CC)
	Feed, ipm	1 to 1-1/2 times that of drill size corresponding to reamer size
	Coolant ^c	No. 1
Tapping	Tool materials ^b	High-speed steels
	Speed, sfpm	7
	Thread tappable, percent of full depth.	50-55
	Coolant ^c	No. 1

^a HSS = high-speed steel; CC = cemented carbide.^b For compositions, see table 10.^c Coolants:

1. Chlorinated, sulfurized fatty mineral and/or sperm oil.
2. Rich solution of soluble oil in water.
3. Chemically active water soluble oil.

cles. In the latter regions, the particles were usually near the centers of the dimples and may have contributed to their formation.

These observations suggest that titanium carbides, nitrides, and perhaps other compounds, concentrated in the cell boundaries and the dendrite interstices where cracks prefer to propagate, reduce the plane-strain fracture toughness of the weld. Conversely,

other things equal, the metal is able to display its superior toughness when these particles are absent or are present only in small quantities.

Filler Wire Composition

It is doubtful that much, if anything, can be done about the location of the harmful particles in the weld deposit. However, by

TABLE 21.—*Tool Geometries for Machining Age-Hardened 18 Percent Nickel Maraging Steels**

[From ref. 100]

Turning:**High-speed steels:**

BR: 0° to 3°; SCEA: 15° to 20°; SR: 0° to 3°; ECEA: 5° to 7°; relief: 5° to 7°; NR: 1/32 inch

Cemented carbides:

Precision-ground throwaway inserts with BR and SR of -5°. For light finish cuts, +5° BR and SR are satisfactory. Square or rectangular inserts are preferred. A chip breaker is required, preferably a mechanical attached type.

Planing:**High-speed steels:**

Roughing: BR: -3°; SR: 6°, lead angle: 35°; SR: 2° to 4°, end relief: 5°; NR: 1/16 inch

Finishing: BR: 3° to 5°, cutting edge inclined at an angle of 12° to 15° with line of travel of the work, end relief: 5°

Parting: BR: 3° to 5°, axial side clearance: 4°; SR: 3°, end relief: 6° break corners

Gooseneck-type tools are suggested. Clapper boxes with return stroke lifting devices are recommended.

Face milling:**High-speed steels:**

AR: 0°; RR: 0°; CA: 45°, face cutting edge angle: not over 3°, face relief: 4°, peripheral relief: 4°

Cemented carbides:

AR: -5° to -7°; RR: -10° to -15°; CA: 45°, face cutting edge angle: not over 3°, face relief: 4°, peripheral relief: 4°

End milling:**High-speed steels:**

Helix angle: 25° to 35°; RR: 0° to 3°, face cutting edge angle: 3°; CA: 45°, face relief: 3° to 4°, peripheral relief: 4° to 5°

Cemented carbides:

Helix angle: 25° to 35°; RR: 0°, face cutting edge angle: 3°; CA: 45°, face relief: 3° to 4°, peripheral relief: 4° to 5°

Slotting:**High-speed steels:**

RR: 0°, side reliefs: 3°, peripheral clearance: 3° to 4°

Cemented carbides:

RR: 0° to -5°, side reliefs: 3°, peripheral clearance: 3° to 4°

Drill grinds:**High-speed steels:**

118°-120° included point angle. Thin the web of the drill at the chisel point 40 to 50 percent of its original thickness, 120°-135° chisel edge angle, 9°-12° lip clearance.

A notch or crankshaft grind of 135° included point angle, 115° to 125° chisel edge angle, 9° lip clearance also can be used.

* Nomenclature is defined in table 12.

increasing the proportion of cell boundaries and interdendritic areas per unit of volume, the unit concentration and, hence, the deleterious effect of the particles, can be reduced. This can be done by decreasing the size of the weld-metal dendrites; a reduction in dendrite size can be brought about, within limits, by reducing the energy input in the welding operation.

Again, by controlling the composition of the weld metal, the number of harmful

intercellular and interdendritic particles can be limited. Major factors determining weld-metal composition are the compositions of the base material and the filler wire.

It has been shown that maximum toughness in maraging steel plate is achieved when residual elements such as carbon, sulfur, oxygen, and nitrogen are at low levels (ref. 117). In a comprehensive program supported by the Navy and NASA, indications were obtained that, to achieve

	C _{max}	Si _{max}	Mn _{max}	Al _{max}	P _{max}	S _{max}
18 Ni 200 grade -----	0.01	0.02	0.10	0.10	0.002	0.005
18 Ni 250 grade -----	.01	.02	.05	.10	.002	.005

plane-strain fracture-toughness values equivalent to those of the base material in GTA welds made in plate having thicknesses up to 1 inch, called for limiting the minor elements in the filler wire approximately as shown above (ref. 118).

Thus, it can be expected that, for optimum weld-metal toughness, both the base material and the filler metal should be extremely low in these elements. Moreover, strong evidence obtained in another research program, supported jointly by the Navy and NASA, indicated that the plane-strain fracture toughness of the weld deposit is inversely related to the oxygen content (ref. 119). Hence, the oxygen content of the filler metal and base material should also be held to very

low values. Presumably, one of the results of limiting the content of these minor and adventitious elements to low levels is the minimization of the formation of carbides, sulfides, and other compounds that detract from fracture toughness.

Other important factors strongly influenced by filler-metal composition are strength, soundness, and freedom from cracking. Thus, the filler wire must contain sufficient amounts of strengthening elements, notably molybdenum and titanium, to insure that, although losses will occur in welding, the deposited metal will nevertheless be rich enough in these elements to attain the desired strength level on subsequent aging. In

TABLE 22.—Data on Taps for Machine or Hand Tapping Age-Hardened 18 Percent Nickel Maraging Steels

[From ref. 100]

Conventional chamfered plug taps are preferred for machine tapping.

Interrupted thread taps are satisfactory.

Serial hand taps are satisfactory.

Conventional taper, plug and bottoming taps are likewise suitable.

Suggested Tap Geometries^a

Rake angle, degrees	Chamfer angle, ^b degrees	Chamfer relief angle, degrees	Land relief
2 to 4	4 to 6	3 to 5	Eccentric ^c

^a Manufacturers' standard back taper.

^b Proportion chamfer angle and number of flutes so the chip load per tooth is not more than 0.004 inch on hot-worked and annealed materials and 0.0015 to 0.002 inch on maraged material.

^c Grind may be full eccentric at pitch diameter and concentric on major diameter with somewhat increased back taper.

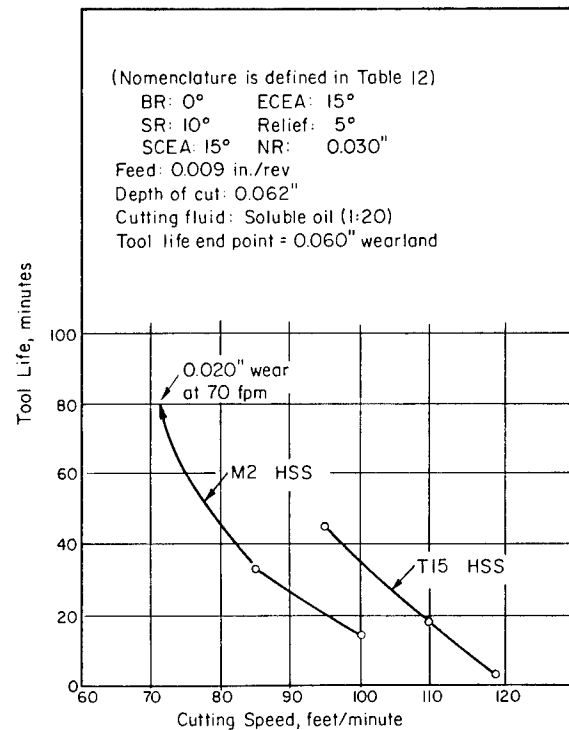

FIGURE 61.—Effect of cutting speed and tool material on tool life in the turning of annealed 18 Ni 300-grade maraging steel (ref. 114).

TABLE 23.—Recommended Conditions for Machining Annealed 18 Ni 300-Grade Maraging Steel^a

[From ref. 114]

Operation	Tool material	Tool geometry	Tool used for tests	Depth of cut, inches	Width of cut, inches	Feed	Cutting speed, ft/min	Tool life	Wear-land, inches	Cutting fluid
Turning	T15 HSS	BR: 0°; SCEA: 15° SR: 10°; ECEA: 15° Relief: 5°	5/8-inch-square tool bit.	0.062	—	0.009 in./rev	95	45 min	0.060	Soluble oil (1:20).
Turning	C-6 carbide	NR: 0.030 in. BR: -5°; SCEA: 15° SR: -5°; ECEA: 15° Relief: 5°	1/2-inch square throwaway insert.	0.062	—	0.009 in./rev	450	30 min	0.008	Soluble oil (1:20).
Drilling	M1 HSS	NR: 0.030 in. 118° plain point 7° clearance	1/4-inch-diameter HSS drill	0.500 through	—	0.005 in./rev	90	200 holes	0.015	Highly sulfurized oil.
Reaming	M1 HSS	Helix angle: 0° CA: 45° Clearance: 7°	2-1/2-inch-diameter 6-flute chucking reamer.	0.500 through	—	0.009 in./rev	75	300 holes	0.006	Highly sulfurized oil.
Tapping	M1 HSS	2-flute plug spiral point 75 percent thread	5/8-24 NF tap	0.500 through	—	—	110	115 holes	Under-size threads	Highly sulfurized oil.

^a Nomenclature is defined in table 12.

TABLE 24.—*Speed and Feed Combinations for Most Reasonable Tool Life When Machining Annealed 18 Ni 300-Grade Maraging Steel*

[From ref. 115]

Operation	Tool material	Tool geometry	Tool used for tests	Feed, in./rev	Cutting speed, ft/min	Tool life, ^a holes	Cutting fluid
Drilling	T15	118° plain point, lip relief; 12° chisel edge angle; 120°	1/2-inch diameter, 4-1/4-inch long.	0.006	95.5	573	Soluble oil (1:20).
Reaming	M7	Rake: 6° to 7° Relief: 17° to 19°	9/16-inch diameter, 6-flute, 1/2-inch diameter shank.	.009	136	63-74 ^b	Soluble oil (1:20).
End milling	14		1/2-inch diameter, spiral 4-flute, 1/2-inch diameter shank.	.019	159	660 in. of work	Soluble oil (1:20).
Tapping	10	Straight 4-flute, hand, plug	5/8-18 NF		21	(^c)	

^a Criteria: Drilling ----- 0.015-inch lip wear

Reaming ----- 0.015-inch wear on chamfer edges

End milling ----- 0.011-inch wear on radial cutting edge

Tapping ----- Last good hole

^b Results of 2 test runs.

^c Holes were not consecutively good. Of 51 and 100 holes tapped in 2 tests at this speed, 60 and 80 percent of the first 50 holes were good, and 53 percent of the 100 holes were good.

TABLE 25.—Recommended Conditions for Machining 18 Ni 300-Grade Maraging Steel in the Age-Hardened Condition*
 [From ref. 114]

Operation	Tool material	Tool geometry	Tool used for tests	Depth of cut, inches	Width of cut, inches	Feed	Cutting speed, ft./min	Tool life, holes	Wear-land, inches	Cutting fluid
Turning	T15 HSS	BR: 0°; SCEA: 15° SR: 10°; ECEA: 5° Relief: 5° 0.030 in.	5/8-in.-square tool bit.	0.062		.009 in./rev	35	80 min	0.026	Soluble oil 1:20
Turning	C-2 carbide	BR: -5°; SCEA: 15° SR: -5°; ECEA: 15° Relief: 5° NR: 0.030 in.	1/2-in.-square throwaway insert.	0.062		0.009 in./rev	175	30 min	0.015	Soluble oil 1:20
Face milling.	T15 HSS	AR: 5°; ECEA: 10° RR: 5° CA: 45° Clearance: 8°	4-in.-diameter single-tooth face mill.	0.060	2	0.005 in./tooth	60	80-in. work travel	0.060	Highly chlorinated oil
Face milling.	C-2 carbide	AR: -7°; ECEA: 5° RR: -7° CA: 45° Clearance: 6°	4-in.-diameter single-tooth face mill.	0.060	2	0.004 in./tooth	140	200-in. work travel	0.015	Dry
Side milling.	C-2 carbide	AR: -7°; ECEA: 45° RR: -7° CA: 45° Clearance: 6°	4-in.-diameter single-tooth face mill.	0.100	1.25	0.004 in./tooth	175	75-in. work travel	0.015	Dry
Peripheral end milling.	M2 HSS	Helix angle: 30° RR: 10° Clearance: 7° CA: 45° x 0.060 in.	3/4-in.-diameter 4-tooth HSS end mill.	0.250	0.75	0.001 in./tooth	40	100-in. work travel	0.012	Highly chlorinated oil
End mill slotting.	T15 HSS	Helix angle: 30° RR: 10° Clearance: 7° CA: 45° x 0.060 in.	3/4-in.-diameter 4 tooth HSS end mill.	0.250	0.750	0.001 in./tooth	43	140-in. work travel	0.012	Highly chlorinated oil
Drilling	T15 HSS	118° plain point Clearance: 7°	1/4-in.-diameter HSS drill	0.500 through		0.001 in./rev	25	250	0.015	Highly sulfurized oil
Reaming	M2 HSS	Helix angle: 0° CA: 45° Clearance: 7°	2-1/2-in.-long 0.272-in.-diameter 6-flute chucking reamer	0.500 through		0.005 in./rev	35	120	0.006	Highly chlorinated oil
Tapping	M1 HSS nitrided	2-flute plug spiral point 75 percent thread	5/16-24 NF tap	0.500 through			7	75	Under-size	Highly chlorinated oil

* Nomenclature is defined in table 12.

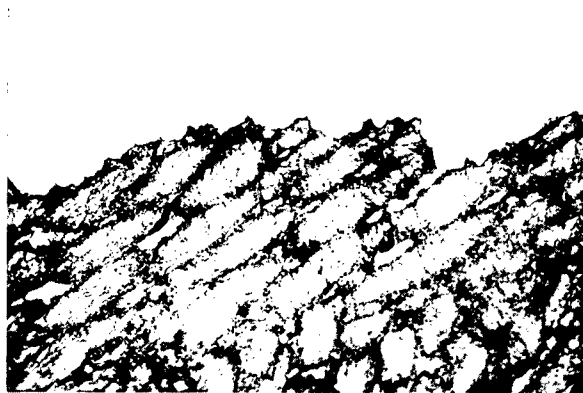
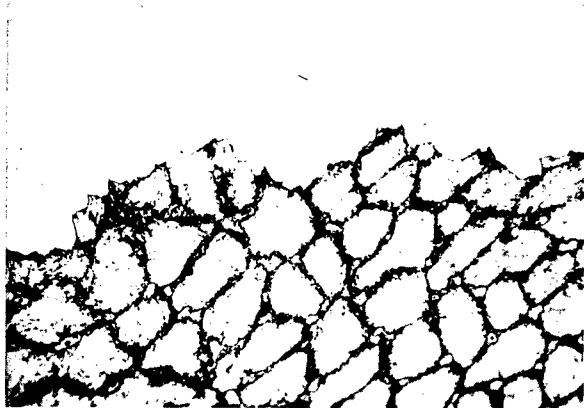

FIGURE 62.—Photomicrographs of the profiles of fracture through 18 Ni 250-grade maraging steel weld metal deposited by the gas-tungsten arc process (ref. 116) $\times 375$.

addition, it is considered that aluminum and titanium reduce the incidence of porosity and the susceptibility to cracking, that molybdenum enhances resistance to hot cracking, and that hydrogen promotes cold cracking (refs. 100 and 120). Thus, although the subject has not yet been completely clarified, it is evident that a combination of factors should be taken into account in arriving at filler-wire compositions. It appears that the best results are obtained when filler wire with a clean contaminant-free surface, which has been produced from vacuum-melted material, is specified (ref. 117). Filler-wire compositions gathered from a number of sources are given in table 26. Somewhat different compositions are offered in table 27 (ref. 121).

NICKEL MARAGING STEELS

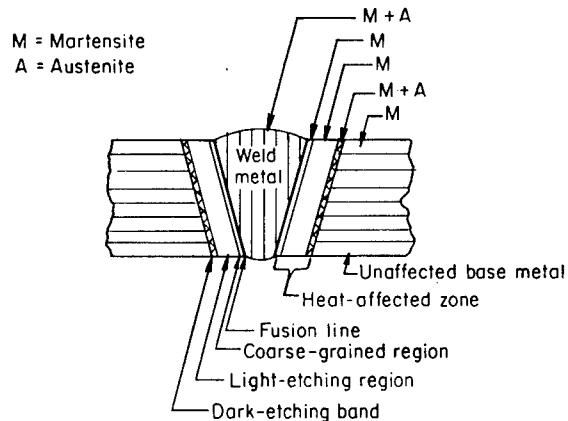

FIGURE 63.—Schematic illustration of the different regions in a maraging steel weldment (ref. 117).

Heat-Affected Zone

As shown in figure 63, the heat-affected zone of a single-pass weld in a maraging steel can contain three distinct bands (refs. 122 and 123). During welding, the base material adjacent to the fusion line is heated to such high temperatures in the austenite region that considerable grain growth occurs. On cooling, the metal transforms to coarse-grained martensite. As stated in chapter 3, the austenite-martensite reaction in maraging steels is truly reversible and, as a consequence, the martensitic transformation product inherits the grain size of the parent austenite. Thus, when the austenite is coarse grained, the martensite formed therefrom will have the same coarse grain size. Only by introducing plastic deformation prior to, or during, the austenitizing treatment can the grain size be changed.

The next band outward from the fusion line is a light-etching martensitic zone that had been heated into the austenitic region, but not high enough to cause appreciable grain growth.

The third band, a dark-etching zone, is where the phenomenon of austenite reversion, as discussed in chapter 3, takes place. The amount of austenite formed is usually quite considerable. In one study, the dark-etching bands in a multipass GTA welded

TABLE 26.—*Filler Wires for Welding the 18-Percent Nickel Maraging Steels*
[From ref. 117]

Welding process ^a	18 Ni steel grade	Composition, weight percent ^b										
		Ni	Co	Mo	Ti	C	Si	Mn	Al	P	S	Other
GTA	200	17.5-18.5	7.5-8.0	3.6-3.8	0.26-0.30	0.03 max	0.01 max	0.10	0.10	0.01 max	0.01 max	40 ppm O ₂ max 5 ppm H ₂ max 40 ppm N ₂ max
GTA	200	(18.1)	(7.84)	(3.62)	(0.28)	(0.01)	(0.02)	(0.08)	° (0.12)	---	---	(23 ppm O ₂) (16 ppm N ₂) (2 ppm H ₂) (10 ppm O ₂) (13 ppm N ₂) (1 ppm H ₂)
GTA (big TIG)	250	(18.12)	(8.11)	(4.70)	(0.48)	(0.01)	(0.01)	(0.03)	(0.11)	(0.002)	(0.005)	---
GTA (big TIG)	250	(18.1)	(8.0)	(4.52)	(0.46)	(0.01)	(0.03)	(0.03)	(0.10)	(0.002)	(0.005)	---
GMA (inert-gas shielded).	200	18.0	4.0	3.5	0.45	(0.009)	---	---	0.15	---	---	---
GMA (inert-gas shielded).	250	18	8	4.5	0.5	0.03 max	0.1 max	0.1 max	0.2	---	---	---
SA (special flux).	250	(18)	(7)	(4.5)	(1.20)	---	(0.01)	(0.03)	---	---	---	---

^a GTA = gas-tungsten arc; GTA (big TIG) = higher arc current and faster arc travel than standard GTA; GMA = gas-metal arc; SA = submerged arc.

^b When available, recommended composition is given. In some cases, typical values are given and are indicated as such by parentheses.

^c Amount added.

TABLE 27.—Effect of Filler Composition on Mechanical Properties of 18-Percent Ni Maraging Steel Welds Made by the GTA Process ^a

[From ref. 121]

Filler					Thickness of weld, inches	Properties as maraged ^b				
Ni	Co	Mo	Ti	Al		Yield strength, ksi	Tensile strength, ksi	Elongation, percent	Reduction in area, percent	Charpy V-notch value, ft-lb
17	7.3	2.0	0.7	0.05	1/2	201	213	10	47	24
18	8.0	4.5	0.5	0.2	0.062	235	246	3.5	18	-----
18	9.5	4.5	0.7	0.2	0.062	271	276	2.5	10	-----

^a GTA = gas tungsten-arc.

^b Aged 3 hr at 900° F.

joint were found by X-ray determination to contain as much as 38 percent austenite, whereas the dark-etching bands in an SA welded joint contained up to 45 percent austenite (ref. 116).

The microstructural features of the heat-affected zone would not be a matter of great concern except for the fact that they can significantly influence the strength and fracture toughness of the joint. The influence of the heat-affected zone microstructure on the tensile strength and the Charpy V-notch value for an 18 Ni 250-grade maraging steel is illustrated in figure 64. The data were obtained from a study of syntheti-

cally produced heat-affected zones that were aged 3 hours at 900° F before and after thermal cycling (ref. 124). The coarse-grained region, resulting from peak temperatures of some 2100° F and above, experienced a strength loss of about 5 percent along with a considerable increase in Charpy V-notch value. The properties of the fine-grained region were about the same as those of the base material. In the dark-etching band that resulted from peak temperatures in the vicinity of 1200° F, the strength loss was about 6 percent, and the Charpy V-notch value increased slightly. Greater strength losses, up to 10 percent, were experienced in the dark-etching band when the energy input was increased above that used in obtaining the data shown in figure 64.

Figure 65 shows the hardness of a synthetically produced heat-affected zone designed to simulate the welding of an 18 Ni 250-grade maraging steel in the age-hardened condition (ref. 121). Softening occurred as the peak temperature increased above 1000° F until the metal reached the fully annealed condition, after which the hardness level remained essentially constant. Postweld aging at 900° F for 3 hours returned the heat-affected zone largely to its original hardness. The two regions that did not fully attain original hardness were the ones in which stable austenite had formed

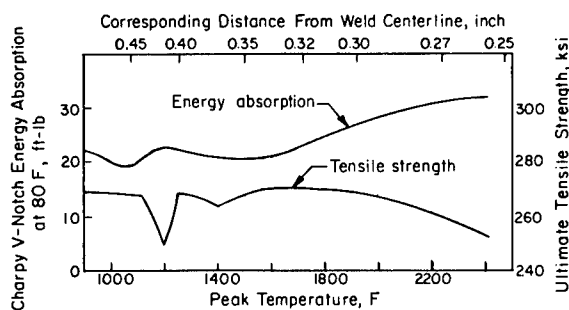

FIGURE 64.—Effect of synthetic weld thermal-cycle peak temperature on mechanical properties of the heat-affected zone in 18 Ni 250-grade maraging steel (ref. 124). (Thermal cycle was equivalent to energy input of 40 Kj/in. for 1/2-inch plate. All specimens were aged 3 hours at 900° F before and after cycling.)

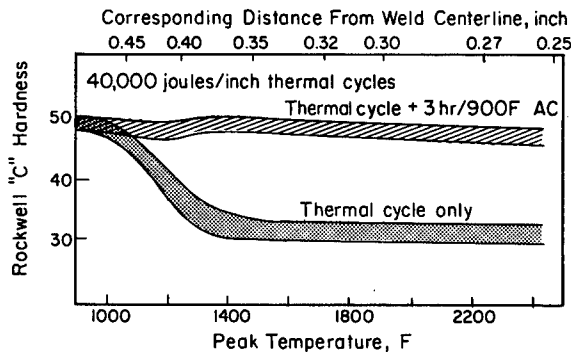

FIGURE 65.—Hardness of thermally cycled specimens simulating the heat-affected zone of an 18 Ni 250-grade maraging steel welded in the age-hardened condition (ref. 121).

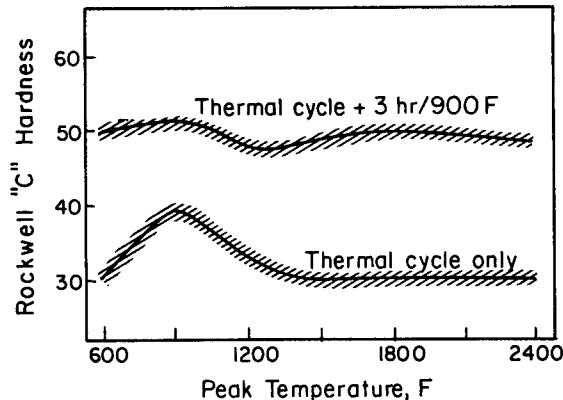

FIGURE 66.—Hardness of thermally cycled specimens simulating the heat-affected zone of an 18 Ni 250-grade maraging steel welded in the annealed condition (ref. 121).

(peak temperatures in the range of 1200° F) and grain coarsening had occurred (peak temperatures above about 1800° F).

The effects of weld thermal cycles on the hardness of material welded in the annealed condition are illustrated in figure 66 (ref. 121). The region that experienced peak temperatures around 900° F age hardened slightly, whereas the regions that saw peak temperatures above 1200° F were not greatly affected. Again, postweld aging 3 hours at 900° F developed full hardness in the heat-affected zone except for the band containing stable austenite and for the grain-coarsened region.

If reductions in strength and hardness, such as are illustrated in figures 64, 65, and 66, cannot be tolerated, a full postweld heat treatment consisting of annealing followed by aging is necessary to obliterate the weak structures and thereby raise the strength to that of the base material.

However, it was found that in multipass welds the heat of subsequent passes restored the hardness of the previously produced coarse-grained regions, and thus such regions of low strength would be present only in the heat-affected zone of the last weld pass (ref. 124). Yet, due to the stability of the reverted austenite, the hardness of dark-etching regions was not restored by the heat of subsequent passes or by using the aging treatment without a prior anneal.

In the comprehensive investigation mentioned earlier, a considerable amount of data on the plane-strain fracture toughness of actual heat-affected zones in multipass welds were obtained from notched bend tests, with the notch located in various regions of the joint (ref. 118). The results, which are summarized in table 28, lack the consistency of those plotted in figure 64. In some cases, the fracture toughness at the various locations in the heat-affected zones was higher and, in other instances, it was lower than that of the base material. This variance undoubtedly reflects the microstructural complexity of the multipass weldments. Perhaps of greater concern was the strong tendency for the weld metal to display low fracture toughness in comparison with the base material, an observation that emphasizes the critical importance of the microstructure and composition of the weld metal.

Input and Dissipation of Heat

As suggested in the foregoing discussion, the degree to which strength deteriorates in the heat-affected zones of welded joints in 18 percent nickel maraging steels is influenced by the energy input during welding. Certainly, this factor affects the extent of the grain-coarsened bands, as well as the width of the dark-etching bands, and the amount of reverted austenite they contain.

TABLE 28.—Fracture Toughness of Various Regions in Welds in 18 Ni Maraging Steels

[From ref. 118]

Steel type	Plate heat ^a	Welding method	Test bar axis ^b in relation to plate rolling direction	Average K_{Ic} values, ksi ^c √in.				
				BM	CW	FZ	HAZ	DB
250 -----	X14636	GTA -----		84.5	83.5	100.5	94.0	92.5
250 -----	X14636	GTA -----		76.5	69.5	81.0	74.5	67.0
250 -----	X53013	GTA (big TIG) -----		92.5	104.0	120.5	128.5	121.0
250 -----	X53013	GTA (big TIG) -----		85.5	95.5	107.5	-----	89.0
250 -----	X14636	GMA (spray) -----		88.0	78.0	-----	107.0	98.5
250 -----	X53013	GMA (spray) -----		78.0	71.5	84.0	93.5	89.5
250 -----	X53013	GMA (dip) -----		87.0	69.5	-----	104.5	-----
250 -----	X53013	GMA (dip) -----		83.0	58.0	97.5	90.0	88.0
200 -----	3960819	GTA -----		120.5	111.0	121.0	121.5	121.5
200 -----	3951215	GTA -----		130.5	112.0	126.5	116.0	118.5
200 -----	3951215	GTA (big TIG) -----		114.0	113.0	142.5	150.0	-----
200 -----	3951217	GTA (big TIG) -----		127.0	110.5	144.0	141.5	126.5
200 -----	3951217	GMA (spray) -----		126.0	70.5	122.5	107.5	100.5
200 -----	3960819	GMA (spray) -----		95.5	62.0	115.5	113.5	109.5
200 -----	3951215	GMA spray on heat- treated plate		---	76.0	111.5	125.5	114.0
200 -----	3951215	GMA (dip) -----		126.0	61.0	113.0	116.5	109.0
200 -----	3951215	GMA (dip) -----		128.0	75.0	134.0	145.5	115.5

^a 3/4-inch plate with the following compositions and properties:

Element, weight percent	Heat X14636, air melted, 250 grade	Heat X53015, air melted, 250 grade	Heat 3951215, vacuum remelted, 200 grade	Heat 3951217, vacuum remelted, 200 grade	Heat 3960819, vacuum remelted, 200 grade
Carbon -----	0.03	0.02	0.025	0.020	0.016
Manganese -----	0.06	0.02	0.09	0.09	0.07
Phosphorus -----	0.005	0.006	0.007	0.007	0.007
Sulfur -----	0.010	0.009	0.006	0.006	0.007
Silicon -----	0.10	0.04	0.05	0.04	0.06
Nickel -----	18.37	4.80	18.35	18.35	18.35
Molybdenum -----	4.70	17.59	4.07	4.05	3.98
Cobalt -----	8.49	8.06	7.55	7.50	7.50
Titanium -----	0.42	0.49	0.19	0.19	0.20
Aluminum -----	0.13	0.07	0.13	0.14	0.13
Yield strength, ksi:					
Parallel to rolling direction	263	258	225	230	233
Perpendicular to rolling direction	248	268	228	225	229

^b || = tests simulate a longitudinal seam weld in a rocket-motor case.

| = tests simulate a girth weld.

^c Unless otherwise noted, welds were made in solution-annealed materials. Test specimens were aged 4

It has been suggested that energy input affects the fracture toughness of the weld metal by influencing dendrite size and, hence, the concentration of undesirable compounds along cell boundaries and dendrite interstices. And, of course, multipass welds usually differ substantially from single-pass welds in these respects, as well as in the location and contour of the different bands.

The various effects that have been observed have led to the formulation of some general rules regarding the heat input for the welding of maraging steels (ref. 125). They are as follows:

- (1) Avoid prolonged times at elevated temperatures;
- (2) Do not preheat, keep interpass temperatures below about 250° F;
- (3) Use minimum possible weld-energy input; and
- (4) Avoid other conditions causing slow cooling rates.

Welding Processes

The 18 percent nickel maraging steels have been joined by all the major welding processes. Illustrative welding parameters are given in table 29 (refs. 126 to 131). Recent emphasis has been placed on process and filler-wire combinations that will permit increased deposition rates and out-of-position welding without sacrificing the fracture toughness of the joint (ref. 117). These efforts have met with some success, but generally the toughest welds are produced by the gas tungsten-arc process. The superior toughness of the welds produced by this process is shown by the values for critical flaw tolerance reproduced in table 30.

Also, as mentioned earlier, an apparent relationship between the oxygen content of welds in 18 percent nickel maraging steels and their plane-strain fracture toughness

has been observed (ref. 119). The pertinent data are presented in bar graph form in figure 67, from which it can be seen that weld deposits with high oxygen contents possessed low fracture toughness, and vice versa. Since the oxygen content of the plate material and the filler wire was, in all cases, less than 30 ppm, the data also indicate that the oxygen content of the welds was influenced by the welding process. Thus, it can be speculated that one reason the GTA processes produce tougher welds than the GMA processes is that the resulting welds tend to be lower in oxygen content.

In addition to standard GTA and GTA (big TIG), efforts have been in progress on the development of a gas tungsten-arc process for welding the maraging steels which involves arc currents considerably higher than those used in the big TIG process (ref. 132). Several investigations have demonstrated that the maraging steels can be welded successfully by the electron-beam process (refs. 123, 133, and 134). These steels have also been welded by the electro-gas, plasma arc, laser beam, spot welding, and seam welding (refs. 100 and 117).

HEAT TREATING

Annealing

As mentioned in chapter 4, the maraging steels are often annealed by heating at 1500° F and air cooling. For improved combinations of strength and toughness, they may be double annealed; the schedule being to heat at 1600° to 1800° F, air-cool to room temperature, reheat at 1400° to 1500° F, and again air-cool.

Furnaces may be open, semimuffle or full-muffle types. The heat source may be electricity, gas, or oil. Fuel oil should be equal to grade 3 and should contain no more than 0.75 percent sulfur, and the fuel gas should

hours at 915° F after machining from weldments.

Notches were located as follows: BM=base metal; CW=center of fusion zone; FZ=approximate fusion line; HAZ=approximate center of heat-affected zone, light etching region; DB=outer edge of heat-affected zone, dark-etching region.

TABLE 29.—Illustrative Welding Parameters Used To Weld 18 Ni Maraging Steels

Welding process	Maraging steel grade, ksi	Plate thickness, inch	Weld-joint design	Weld pass	Arc voltage, volt	Arc current, amp	Arc travel speed, ipm	Filler wire diameter, inch	Filler wire feed, ipm	Shielding gas	Welding heat input, kJ/in./pass	Reference
GTA ^a	200	5/8	Single-U	1	9	100	8	1/16	10	10 cfh A + 40 cfh He	6.8	126
				2	9	150	8	1/16	10	"	10.1	126
				3	9	195	8	1/16	20	"	13.2	126
				4	19	200	8	1/16	20	"	15.0	126
				5	10	200	8	1/16	20	"	15.0	126
				6-12	10	225	8	1/16	30	"	16.9	126
GTA ^b (big TIG)	250	3/4			10	340	12-15			40 cfh A	13.6-17.0	127
GTA	250	5/8	Double-V	1-14	25-28	150		1/16		35 cfh A		128
GMA ^c (spray)	200	1/2	Single-V	1-10	32	230	24	0.035		50 cfh A	18.4	129
GMA ^d (spray)	250	3/4	Single-V		27	335	9	1/16	165		60.3	128
GMA ^e (dip)	250	3/4	Single-V	1-18	20	250	16	0.030	140	He	18.8	130
GMA ^f (a-c)	250	3/4	Single-V	1-18	22	210	10		169		40.9	130
SA ^g	250	3/4		1-2	28-32	460-480	7-1/4			Flux	107-127	131

^a GTA = conventional gas-tungsten-arc process.^b GTA (big TIG) = gas-tungsten-arc process with higher arc current and faster arc travel than conventional GTA.^c GMA (spray) = gas-shielded metal-arc process with spray transfer.^d GMA (dip) = gas-shielded metal-arc process with dip transfer.^e SA = submerged arc process.

TABLE 30.—Critical Flaw Tolerance at Center of Weld Fusion Zone ^a

[From ref. 118]

Steel grade, ksi	Welding process ^b	Nominal hardness of base plate, R_c	Average hardness of center of weld, R_c	Mean K_{Ic} value, ksi $\sqrt{\text{in.}}$	Minimum K_{Ic} value, ksi $\sqrt{\text{in.}}$	Calculated radius of surface crack ($a=c$) tolerated at $0.9 \sigma_{ys}$ based on mean K_{Ic} , in.	Calculated radius of surface crack ($a=c$) tolerated at $0.9 \sigma_{ys}$ based on minimum K_{Ic} , in.
250	GTA (big TIG)	52	49	104.0	92.5	0.115	0.091
250	GTA	52	50.5	83.5	60.0	.074	.038
250	GMA (spray)	52	49.0	73.5	64.5	.057	.044
250	GMA (dip)	52	50.0	69.5	59.5	.051	.038
250 ^c	SA			41.0	35.0	.028	
200	GTA (big TIG)	48.5	49.5	113.0	86.5	.181	.106
200	GTA	48.5	50.0	111.0	96.5	.175	.132
200	GMA (spray)	48.5	49.5	70.5	61.5	.070	.054
200	GMA (dip)	48.5	50.0	61.0	50.0	.053	.035

^a Welds were made perpendicular to plate rolling direction to simulate a longitudinal seam in a rocket-motor case. All plate was 3/4 inch thick.

^b GTA=conventional gas-tungsten-arc process.

GTA (big TIG)=gas-tungsten-arc process with higher arc current and faster arc travel than conventional GTA

GMA (spray)=gas-shielded metal-arc process with spray transfer

GMA (dip)=gas-shielded metal-arc process with dip transfer

SA=submerged arc process.

^c Data from ref. 22.

^d Based on $0.75 \sigma_{ys}$ of base plate.

contain no more than 100 grains of total sulfur per 100 cubic feet (ref. 100).

No special furnace atmospheres are required to prevent decarburization because of the low carbon content of the maraging steels. Normal precautions to prevent carburization, sulfidation, or excessive oxidation are required. To produce an oxide-free surface, the work may be heated and cooled to room temperature in an atmosphere of either pure, dry hydrogen with a dewpoint of -45°F or completely dissociated ammonia with a dewpoint of -50° to -60°F (ref. 100).

The work should be completely clean before annealing. All surfaces should be free of all carbonaceous matter, sulfurous compounds, and shop soil. Direct impingement of flames on the charge should be avoided.

Age Hardening

The usual age-hardening temperature is 900°F , the time varying generally from 3

to 6 hours (ref. 98). Air is commonly used as the heat-treating atmosphere. The temperature of the load must be uniform and held within fairly narrow limits. It is advisable to maintain the temperature at all parts of the load within $\pm 10^\circ \text{F}$ of the desired temperature. This is fairly easy to do with electric furnaces, but often is difficult to do with gas- or oil-fired units unless provisions are made to circulate the hot gases. In fact, for the most uniform results, forced circulation furnaces are recommended regardless of the heat source.

Dimensional Changes

The nature of the hardening reactions that occur in the maraging steels is such that a high degree of dimensional stability is maintained throughout the treatment. The length changes that take place during heat treatment of the 18 Ni 250 grade are shown diagrammatically in figure 68. The lack of retained austenite insures that the alloys

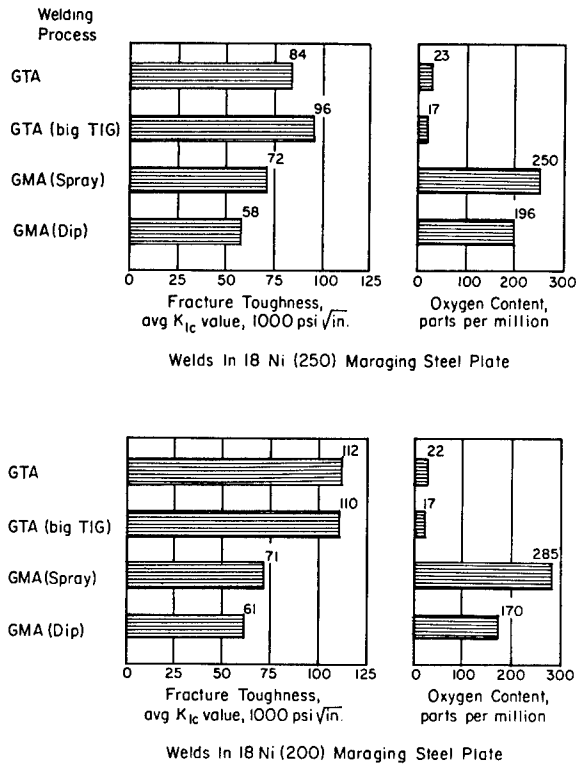

FIGURE 67.—Relationship of oxygen content to fracture toughness in maraging steel welds (ref. 119).

- GTA = conventional gas tungsten-arc process
- GTA (big TIG) = gas tungsten-arc process with higher arc current and faster arc travel than conventional gas tungsten-arc process
- GMA (spray) = gas-shielded metal-arc process with spray transfer
- GMA (dip) = gas-shielded metal-arc process with dip transfer

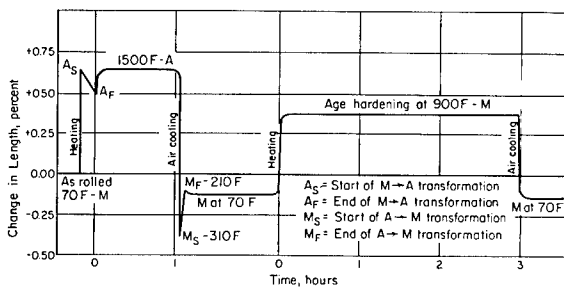

FIGURE 68.—Diagrammatic representation of the dimensional changes that occur during heat treatment of the 18 Ni 250 grade of maraging steel (ref. 100)

will undergo no further dimensional changes after heat treatment. Furthermore, because of the slight uniform dimensional changes occurring during the aging treatment, the amount of distortion that takes place is extremely small.

Nominal values have been reported for the length changes that occur on age hardening and are as follows (ref. 100):

Units	18 Ni 200 grade	18 Ni 250 grade	18 Ni 300 grade
in./in. -----	-0.0004	-0.0006	-0.0008
Percent -----	-.04	-.06	-.08

These values will vary slightly with processing history. Also if the steels are over-aged by heating at higher temperatures or for longer times than standard, the amount of shrinkage will be increased over the values just cited.

Nitriding

In numerous machinery and structural applications, the resistance of the component to wear, sizing, and fatigue is significantly enhanced by a case-hardening treatment. In this regard, carburizing, cyaniding, or carbonitriding treatments are not attractive for case hardening the maraging steels because they promote austenite formation in the case which reduces, rather than increases, its hardness. However, it has been reported that the maraging steels can be gas nitrided successfully (refs. 135, 136, 137, and 138).

A satisfactory procedure is to treat the work in the annealed condition using temperatures of 800° to 850° F for times from 20 to 48 hours in an atmosphere of 25 percent to 30 percent dissociated ammonia (refs. 135, 136, and 137). Under these conditions, the work is simultaneously nitrided and age hardened. Surface hardness values up to 67 Rockwell C are obtainable along with full age-hardened properties in the case. The cases are rather shallow, seldom exceeding 0.006 inch in depth.

TABLE 31.—*Duplex Procedure for Pickling Maraging Steels*

[From ref. 100]

	Solution no. 1	Solution no. 2
Water	3/4 gal	1 gal
Hydrochloric acid (20° Bé) ..	1 gal	
Nitric acid (70 percent)	3/8 gal
Hydrofluoric acid (52 percent)	1/2 pt
Temperature	160° F	80° F
Time	20 to 40 min ^a	1 1/2 to 2 min
Containers ..	Earthenware crocks, glass, ceramic, or acidproof brick-lined tanks	Carbon or brick-lined tanks

^a Additional time may be required to loosen heavy scale.

Standard nitriding temperatures of 975° to 1000° F and normal age-hardening temperatures of 900° to 925° F cannot be used because the long nitriding times cause austenite reversion and thus loss in strength.

DESCALING AND PICKLING

Two pickling procedures have been recommended: a duplex process and a single solution method (ref. 100). In the duplex process, which effectively removes surface oxide and produces a clean, reasonably smooth surface, the work is immersed in solution No. 1 shown in table 31. The time allotted for this depends on the nature and the amount of oxide present. To avoid overpickling the work should be frequently inspected during the operation. On removal from solution No. 1, the work should be rinsed in cold water and immersed in solution No. 2, after which it should again be rinsed in cold water and then neutralized in a 1- to 2-percent (by volume) ammonia solution.

TABLE 32.—*Single Bath Procedure For Pickling Maraging Steels*

[From ref. 100]

Water	5 gal
Sulfuric acid: (66° Bé, 93 percent)	3 qt
or	or
(60° Bé 78 percent)	1 gal
Temperature	150° to 175° F
Time	About 15 min ^a
Containers	Earthenware crocks, glass or ceramic vessels, or rubber-lined tanks

^a Inspect the work frequently to avoid overpickling.

The single solution, shown in table 32, pickles rapidly and leaves a black smut on the surfaces of the work. Following the pickling operation, the work should be rinsed in cold water and then neutralized in a 1- to 2-percent (by volume) ammonia solution.

CHAPTER 6

Mechanical and Physical Properties of 18 Percent Nickel Maraging Steels

The unusual combination of strength and toughness that can be obtained with maraging steels has been noted previously in this report. This advantage and other advantages such as ease of heat treating and good weldability were recognized early in the development of maraging steels. Because new applications for high-strength steels were being considered by the Air Force and NASA, particularly for large solid-propellant booster cases, considerable research effort was expended in the development and evaluation of the maraging steels. As a result of this accelerated developmental effort, a large volume of mechanical property data was accumulated. At the same time, improvements were made in composition control, in reduction of segregation, and mill processing procedures, etc. These processing improvements resulted in improved quality and a higher degree of reliability in achieving the intended properties. At the present time several mills will supply maraging steels in at least three grades representing three strength levels. Further research is being conducted to increase the useful strength level while retaining sufficient toughness for certain types of structures.

Because of the large volume of data on the mechanical properties of maraging steels, it is not feasible to present a statistical analysis of these properties from the available sources. Instead the data on mechanical properties will indicate typical or representative properties, or in some cases, mini-

mum design values. In reporting properties such as fatigue life or fracture toughness for which various testing methods have been used, only selected data representing the best testing procedures are presented. The mechanical properties discussed in this chapter are for the 18-percent nickel types of maraging steels only.

SPECIFICATIONS FOR COMPOSITION AND PROPERTIES

The mechanical properties that can be achieved with maraging steels depend on the composition and the specified heat treatment. Specifications for composition and properties from two different sources are presented in tables 33 and 34 (refs. 139 and 140). In the ASTM designation: A538-65, grade A is commonly known as 200-grade, grade B is 250-grade, and grade C is 300-grade maraging steel. The ranges for yield strength in these grades allow for some variation in composition. The usual heat treatment involves solution annealing at 1500° F for a sufficient time to obtain thorough heating followed by cooling in air. Heating at 900° F for 3 hours is the usual aging treatment. For critical applications it is desirable to obtain specimens for testing from the plate or bar stock as supplied by the mill to check the response of the material to the aging treatment. For some heats, variations in the aging temperature or time at temperature may be beneficial in obtaining the desired properties.

TABLE 33.—*Chemical and Tensile Requirements for 3 Grades of Maraging Steel According to ASTM Designation A538-65*

[From ref. 139]

Chemical requirements, percent	Grade A	Grade B	Grade C
Carbon, maximum -----	0.03	0.03	0.03
Nickel -----	17.0-19.0	17.0-19.0	18.0-19.0
Cobalt -----	7.0-8.5	7.0-8.5	8.0-9.5
Molybdenum -----	4.0-4.5	4.6-5.1	4.6-5.2
Titanium -----	0.10-0.25	0.30-0.50	0.55-0.80
Silicon, maximum -----	0.10	0.10	0.10
Manganese, maximum -----	0.10	0.10	0.10
Sulfur, maximum -----	0.010	0.010	0.010
Phosphorus, maximum -----	0.010	0.010	0.010
Aluminum -----	0.05-0.15	0.05-0.15	0.05-0.15
Boron (added) -----	0.003	0.003	0.003
Zirconium (added) -----	0.02	0.02	0.02
Calcium (added) -----	0.05	0.05	0.05
Tensile requirements:			
Tensile strength, ksi, minimum -----	210	240	280
Yield strength, 0.2 percent offset, ksi -----	200-235	230-260	275-305
Elongation in 2 inches, percent, minimum -----	8	6	6
Reduction in area for round specimens, percent, minimum -----	40	35	30

The specifications in table 34 are for compositions and properties for certain product forms, such as sheet, plate, bar, and forgings.

PROPERTIES OF SOLUTION-ANNEALED MARAGING STEELS

Tensile properties and hardness of solution-annealed maraging steels are presented in table 35 (ref. 141). The alloys are machinable and may be cold formed in this condition. The mills will usually supply the alloys in the solution-annealed condition if desired. Air cooling after heating to 1500° F is sufficient for developing the low-carbon martensitic structure which is characteristic of the solution-annealed condition, although water quenching has been used in some instances.

EFFECTS OF VARIATIONS IN SOLUTION- ANNEALING AND AGING TREATMENTS ON THE PROPERTIES

The solution-annealing temperature of 1500° F is usually used for the 200, 250, and 300 grades of maraging steels. This temperature was selected after a series of solution-annealing and aging temperatures were evaluated during the development of these alloys. The results of a more recent series of tests, showing the effect of varying the solution-annealing temperature, are shown in figure 69. These data indicate that some variation in the annealing temperature can be tolerated.

Mechanical properties of specimens from each of three grades of maraging steel which had been solution annealed at 1500° F and

TABLE 34.—Composition and Tensile Properties for 5 Grades of Maraging Steel as Specified in Aerospace Material Documents

[From ref. 140]

Composition, percent	AMD 64 BL ^a (sheet, strip, plate)		AMD 64 BM ^a (sheet, strip, plate)		AMD 64 BN (bars, forgings, tubing)		AMD 64 BP-1 ^a (bars, forgings, tubing, rings)		AMD 64 BR-1 ^a (bars, forgings, tubing, rings)	
	Min	Max	Min	Max	Min	Max	Min	Max	Min	Max
Carbon -----	-----	0.03	-----	0.03	-----	0.03	-----	0.03	-----	0.03
Manganese -----	-----	.10	-----	.10	-----	.10	-----	.10	-----	.10
Silicon -----	-----	.10	-----	.10	-----	.10	-----	.10	-----	.10
Phosphorus -----	-----	.010	-----	.010	-----	.010	-----	.010	-----	.010
Sulfur -----	17.5	.010	-----	.010	-----	.010	-----	.010	-----	.010
Nickel -----	7.5	18.5	18.0	19.0	17.5	18.5	17.0	19.0	18.0	19.0
Cobalt -----	4.7	8.5	8.5	9.5	7.5	8.5	7.0	8.5	8.0	9.5
Molybdenum -----	.30	5.2	4.7	5.2	4.7	5.2	4.6	5.1	4.6	5.2
Titanium -----	.050	.50	.50	.80	.30	.50	.30	.50	.55	.80
Aluminum -----	-----	.15	.5	.15	.05	.15	.05	.15	.05	.15
Calcium (added) -----	-----	.05	-----	.05	-----	.05	-----	.05	-----	.05
Zirconium (added) -----	-----	.02	-----	.02	-----	.02	-----	.02	-----	.02
Boron (added) -----	-----	.003	-----	.003	-----	.003	-----	.003	-----	.003
Tensile properties:										
Tensile strength, ksi	250		280		250		260 ^d		290 ^d	
Yield strength, ksi	240		270		245		250 ^d		280 ^d	
Elongation in 2 inches, percent	(b)		(c)		5		4-6 ^d		4-5 ^d	
Reduction in area, percent	-----		-----		35		4-45 ^d		4-35 ^d	

^a Consumable electrode melted.^b Elongation is dependent on thickness: Up to 0.065 inch, 2.0 percent min; 0.065 to 0.090 inch, 3.0 min; 0.090 to 0.125 inch, 4.0 min; 0.125 to 0.250 inch, 5.0 min; 0.250 to 0.375 inch, 6.0 min; over 0.375 inch, 8.0 min.^c Elongation is dependent on thickness: Up to 0.100 inch, 2.0 percent min; 0.100 to 0.375 inch, 4.0 min; over 0.375 inch, 8.0 min.^d For bars and forgings under 2.5 inch thick, longitudinal and transverse specimens.^e For longitudinal specimens (4 percent elongation and 40 percent reduction in area are minimum values for transverse specimens).^f For longitudinal specimens (3 percent elongation and 30 percent reduction in area are minimum values for transverse specimens).

TABLE 35.—Tensile Properties and Hardness of Solution-Annealed Maraging Steels

[From ref. 141]

Grade	Yield strength 0.2 percent offset, ksi	Tensile strength, ksi	Elongation in 4 D, percent	Reduction in area, percent	Rockwell C hardness
200 ---	110	140	18	72	27-29
250 ---	100	140	19	78	28-30
300 ---	110	150	18	72	30-32
350 ---	120	165	18	70	35

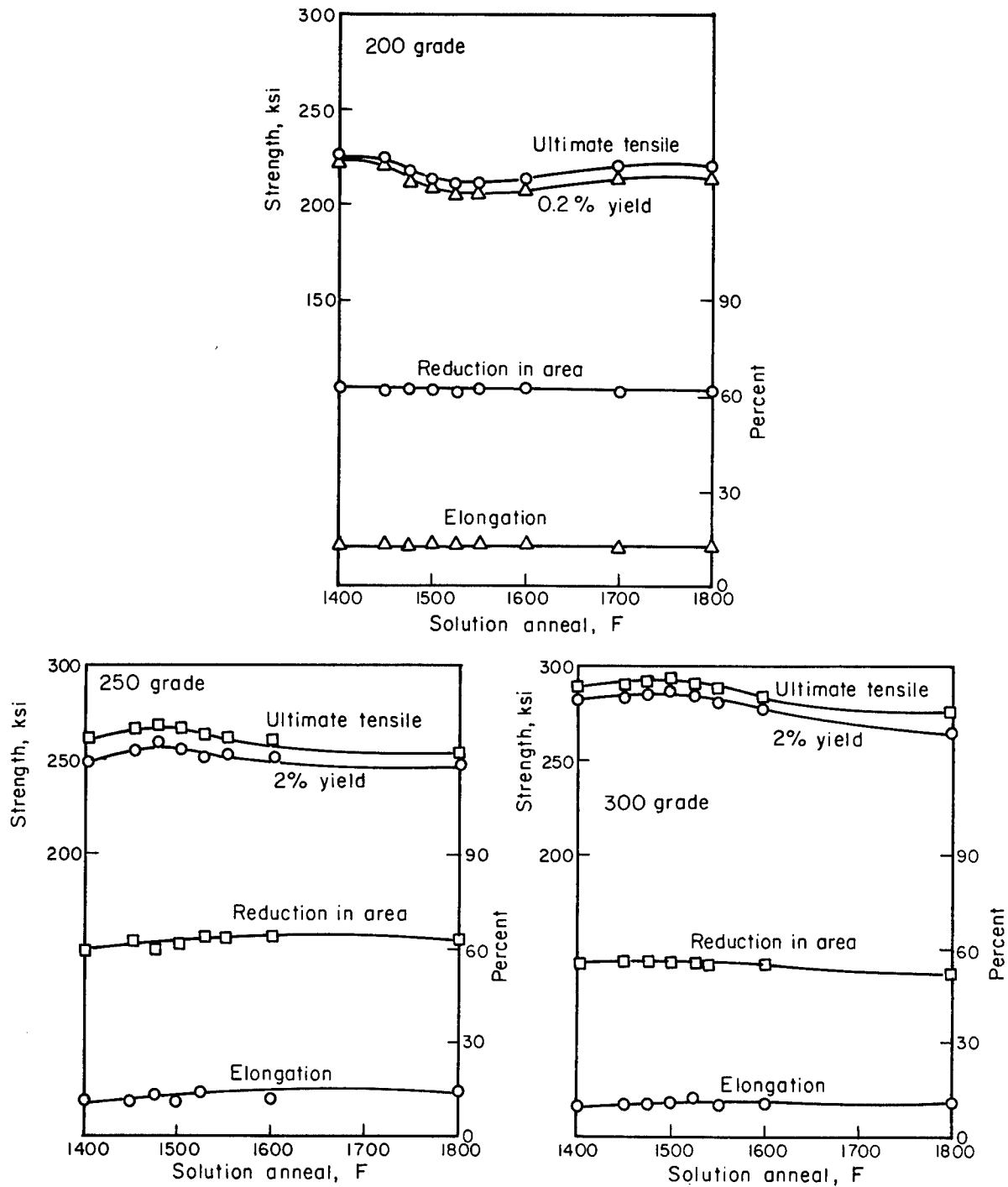

FIGURE 69.—Effect of solution-annealing temperature on the tensile properties of 200-, 250-, and 300-grade maraging steel after aging at 900° F for 3 hours (ref. 141; courtesy Vanadium-Alloys Steel Co.) Condition: Solution annealed at the indicated temperatures for 30 minutes.

aged at various temperatures for 3 hours are shown in figure 70. It is obvious from these curves that aging at 900° F develops the maximum strength in specimens from these particular heats. This is characteristic of most heats of maraging steel for the 200, 250, and 300 grades. However, in some instances it is advisable to determine the aging response of a specific heat or plate of steel before the component or components from this heat or plate are aged. For some heats an aging temperature of 850° or 950° F produces maximum strength. For the 350 grade of maraging steel the supplier may recommend a solution-annealing temperature of 1400° F or 1475° to 1525° F, and an aging temperature of 925° to 950° F with an aging time of 3 hours. An alternate aging treatment is 900° F for 6 to 12 hours.

The effect of variations in aging time on the tensile properties of specimens from one heat of 250-grade maraging steel is shown in figure 71. For these specimens, increasing the aging time from 3 to 6 hours resulted in a slight increase in the strength. As the figure shows, doubling the time at temperature for the aging treatment has little effect on the tensile properties. This characteristic is important in the fabrication of large components, such as solid-propellant motor cases. In one example the capacity of the largest, available aging furnace was smaller than the largest motor cases and the completed motor cases could not be aged in one piece. Instead, individual segments of the motor cases were aged in the largest available furnace. The segments were then welded together at girth welds. Each girth weld was locally aged using heaters that encircle the motor case. The parent metal near each girth weld was aged twice in this process, but the additional aging treatment had little effect on the properties of the parent metal (ref. 142).

TENSILE PROPERTIES AT ROOM TEMPERATURE

Room-temperature tensile properties of the commercial grades of maraging steel are designated by certain specifications as presented in tables 33 and 34. However, typical

properties for vacuum-arc-remelted alloys such as billets are shown in table 36. These data indicate that the material in large billets forged from vacuum-arc-remelted ingots develops relatively uniform properties on aging. However, good control of casting and processing variables is required, as well as a certain amount of reduction by forging or hot rolling, to obtain uniform properties. One of the advantages of the maraging steels for large forgings is that there is no hardenability limitation as there is for low-alloy steels such as AISI 4340. Maraging steel forgings 10 and 12 inches thick harden throughout on aging.

In evaluating the tensile properties of maraging steels as plate and sheet, the results will vary somewhat depending on the thickness. This effect is shown in table 37. For the higher strength compositions, there is a tendency for tensile specimens to exhibit lower strengths and lower ductility as the thickness of the sheet is reduced.

Typical room-temperature properties of 350-grade maraging steel are presented in table 38.

TENSILE PROPERTIES AT ELEVATED TEMPERATURES

In some applications maraging steels may be exposed to moderately elevated temperatures. The effect of elevated temperatures on the short-time tensile properties of three grades of maraging steel is shown in table 39. Increasing the testing temperature causes a reduction in tensile strength and an increase in ductility for round specimens.

Data from another source also show the trend for tensile data at elevated temperatures (ref. 143). These data are summarized in tables 40 and 41. In obtaining the data for these tables, 10 specimens of each orientation were tested at room temperature, and 5 specimens of each orientation were tested at each of the elevated temperatures. The maximum and minimum values for each condition are presented in the tables to show the amount of spread that may occur in such tests. Increasing the test-

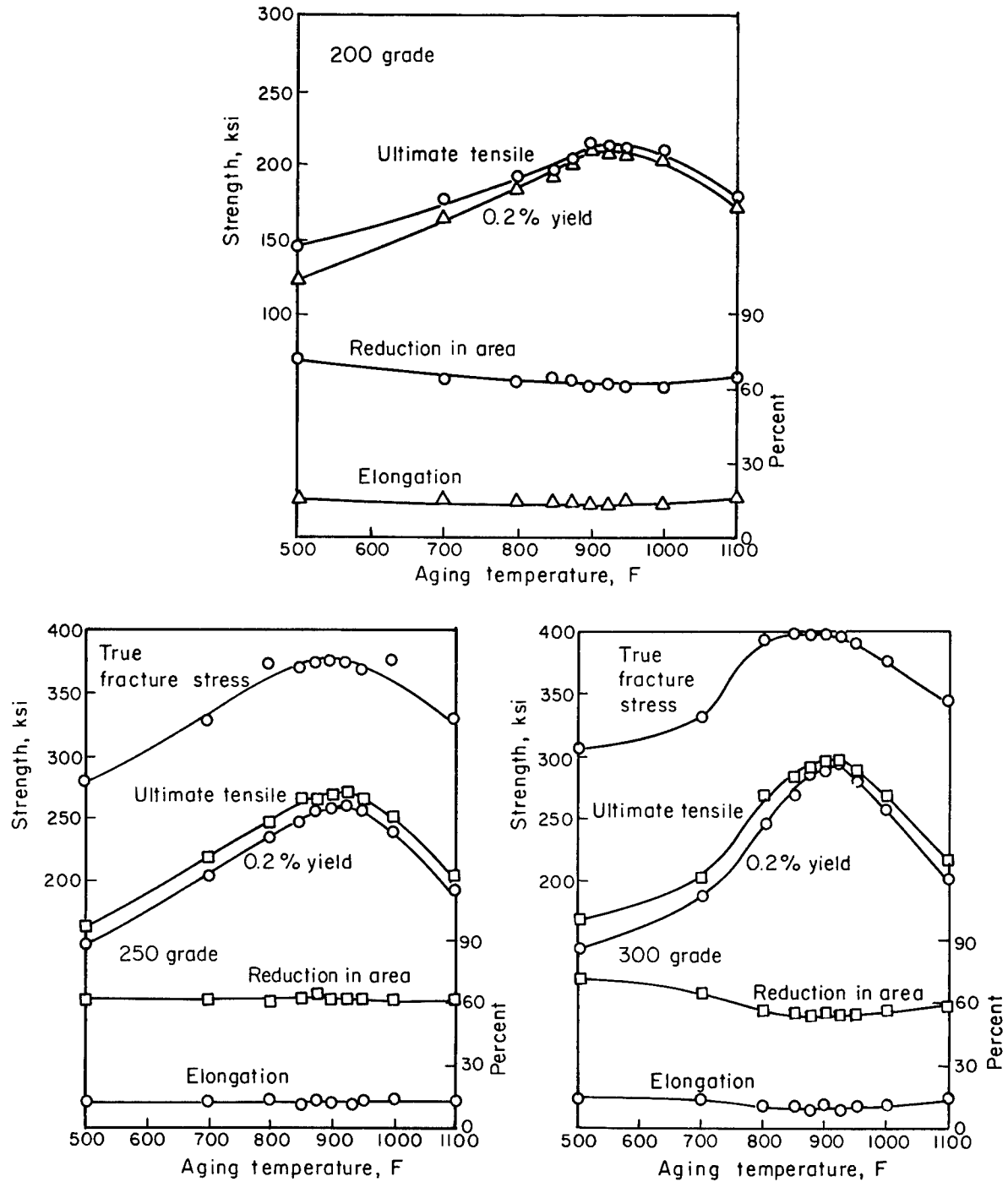

FIGURE 70.—Effect of aging temperature on the tensile properties of 200-, 250-, and 300-grade maraging steel after solution annealing for 30 minutes at 1500° F (ref. 141; courtesy Vanadium-Alloys Steel Co.) Condition: Aged 3 hours at indicated temperatures.

ing temperature has little effect on the elongation of sheet-type specimens of maraging steels.

Exposure at 1000° F causes overaging with a substantial reduction in strength at the exposure temperature and at room temperature after exposure (ref. 144).

The curves in figure 72 show the effect of elevated temperatures on the tensile properties of round specimens of 250-grade maraging steel. The dashed curve shows the effect of 200-hour exposure at the testing temperature on the yield strength. The effect of overaging for extended times at 900° and 1000° F is evident from this curve.

Stress-strain curves for elevated temperature tensile tests on 250-grade maraging steel are shown in figure 73.

TENSILE PROPERTIES AT LOW TEMPERATURES

Tensile properties for specimens of 0.025-inch sheet of 250-grade maraging steel are presented in table 42 for testing temperatures of 75°, -100°, -320°, and -423° F (ref. 145). Values for yield strength, ultimate strength and elastic modulus are increased by decreasing the testing temperature while the ductility is decreased. The room-temperature tensile properties of the specimens from this heat indicate that the composition is on the borderline between the 250 and 300 grades. However, because of the low ductility and associated low toughness of the maraging steels at cryogenic temperatures, use of these steels at very low temperatures is not recommended.

COMPRESSIVE PROPERTIES AT ELEVATED TEMPERATURES

Compressive properties for specimens of 0.070-inch sheet at room temperature and at elevated temperatures are shown in table 43. This is the same alloy that was used for the tensile test data in table 40. As before, the maximum and minimum values are reported to show the spread in individual test data.

Compressive properties of bar material from the same heat of 250-grade maraging steel also are shown in table 43. The bar

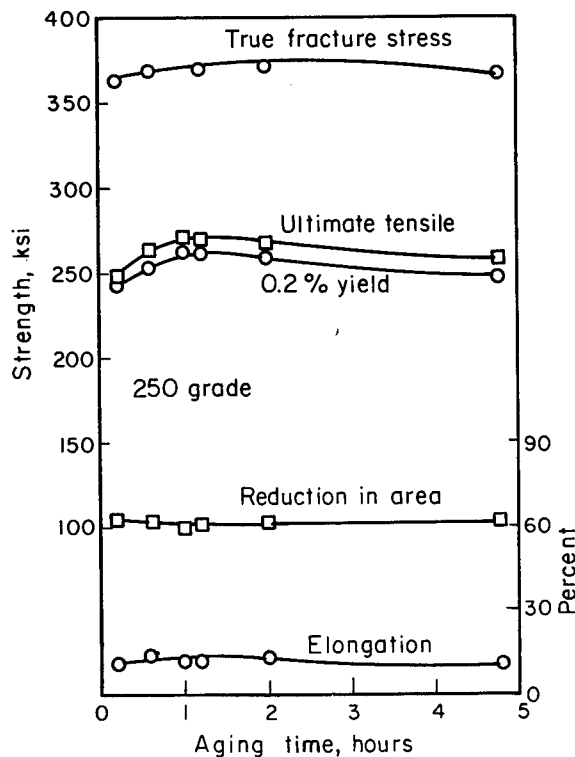

FIGURE 71.—Effect of aging time at 900° F on the tensile properties of 250-grade maraging steel after solution annealing for 30 minutes at 1500° F (ref. 141; courtesy Vanadium-Alloys Steel Co.).

specimens had slightly higher yield strength values than the sheet specimens at each testing temperature.

The compressive yield strength of a high-strength alloy usually is slightly higher than the tensile yield strength at 0.2 percent offset. Typical ratios of compressive yield strength to tensile yield strength for different forms and grades of maraging steel are shown in table 44 (ref. 146).

DYNAMIC MODULUS OF ELASTICITY OF MARAGING STEELS

Results of dynamic modulus of elasticity tests for 250- and 300-grade maraging steels at room temperature and at elevated temperatures are presented in table 45. Values for dynamic modulus usually are intermediate between the corresponding tensile and compressive values. The values for

TABLE 36.—*Typical Room-Temperature Tensile Properties of Billets of 200-, 250-, and 300-Grade Maraging Steel After Solution Annealing at 1500° F For 30 Min and Aging at 900° F for 3 Hr*

[From ref. 141]

Grade	Size, inches	Location	Yield strength 0.2 percent offset, ksi	Tensile strength, ksi	Elongation in 4 D, percent	Reduction in area, percent
200 ----	4 round	MR ^a	203	210	11	50
		C ^a	203	208	11	50
	5 square	MR	196	204	12	52
		C	195	203	12	56
	8 square	MR	196	205	12	50
		C	195	204	11	51
10 square	MR	195	203	12	49	
	C	193	203	11	50	
250 ----	4 round	MR	255	257	8.0	42
		C	256	259	8.0	43
	6 square	MR	254	260	9.0	47
		C	260	262	9.0	46
	6 round	MR	248	253	8.5	41
		C	248	252	8.0	36
12 square	MR	247	251	7.0	28	
	C	248	253	8.0	34	
300 ----	9 square	MR	274	279	7.0	37
		C	272	282	7.0	36
	4 round	MR	273	278	9.0	48
		C	271	278	9.0	44
	6 square	MR	278	282	8.0	41
		C	279	283	10.0	48
10 square	MR	277	286	8.5	38	
	C	275	284	8.5	40	

^a MR=mid radius; C=center.

TABLE 37.—*Effect of Thickness on Room-Temperature Tensile Properties*

[From ref. 141]

Grade	Thickness, inch	Yield strength 0.2 percent offset, ksi	Tensile strength, ksi	Elongation, percent in —	
				1 inch	2 inches
200 -----	0.500	204	209	13	-----
	0.320	202	208	14	-----
	0.080	213	215	7.2	3.9
	0.060	207	216	6.5	3.5
300 -----	0.250	315	321	9.0	5.0
	0.125	314	317	6.8	3.4
	0.090	308	313	6.0	3.2
	0.065	301	307	5.0	3.0
	0.045	292	295	4.0	2.0
	0.025	294	296	2.0	1.0

Condition: Vacuum arc remelted, solution annealed at 1500° F for 30 min (200 grade) or 15 min (300 grade), and aged at 900° F for 3 hr.

TABLE 38.—*Typical Room-Temperature Tensile Properties of 350-Grade Maraging Steel Solution Annealed at 1500° F for 1 Hr and Aged as Indicated*

[From ref. 141]

Material	Orientation	Aging treatment	Hardness, Rc	Yield strength, 0.2 percent offset, ksi	Tensile strength, ksi	Elongation in 4 D or 1 inch, percent	Reduction in area, percent
½-in. Plate	Transverse	900° F, 3 hr	59	345	352	8.5	44
	Center, longitudinal	900° F, 6 hr	---	354	357	5.8	32
2-1/2 in. round	Longitudinal	950° F, 3 hr	58	350	362	5.8	---
	---	900° F, 6 hr	58	356	366	4.8	---
0.060-in. sheet	---	950° F, 3 hr	58	358	370	4.3	---
	Transverse	900° F, 6 hr	58	364	373	4.0	---

TABLE 39.—*Typical Elevated Temperature Tensile Properties of 200, 250, and 300 Grades of Maraging Steel After Solution Annealing at 1500° F for 30 Min and Aging at 900° F for 3 Hr*

[From ref. 141]

Maraging steel grade	Testing temperature, °F	Yield strength 0.2 percent offset, ksi	Tensile strength, ksi	Elongation in 4.5 √ A, ^a percent	Reduction in area, percent
200 -----	70	208	213	12	62
	600	166	176	12	60
	800	154	167	14	61
	900	142	151	18	66
	950	127	138	18	70
250 -----	70	254	263	11	56
	600	234	244	12	56
	700	224	235	12	56
	800	211	227	14	58
	900	192	207	16	65
	950	177	191	21	71
300 -----	70	282	288	12	62
	600	240	250	12	62
	700	236	246	12	62
	800	223	240	14	61
	900	203	216	17	68
	950	181	196	22	76

^a This factor permits correlations of elongation for specimens of different diameters. A = cross-section area.

TABLE 40.—*Elevated Temperature Tensile Properties of 0.070-Inch Sheet of 250-Grade Maraging Steel Heat A ^a*

[From ref. 143]

Testing temperature, °F	Specimen orientation	Yield strength 0.2 percent offset, ksi	Tensile strength, ksi	Elongation in 2 inches, percent	Elastic modulus, 10 ⁶ psi
75 -----	L	251-264	258-268	3	24.5-27.6
	T	254-271	258-275	3	26.1-28.3
300 -----	L	235-247	239-251	3-4	23.4-24.6
	T	225-246	230-251	3-4	24.8-26.0
600 -----	L	219-224	227-231	3-3.5	22.8-25.4
	T	211-232	217-240	2-3.5	23.8-24.8
800 -----	L	197-205	213-218	3-3.5	20.7-22.8
	T	199-209	210-225	2.5-3.0	22.5-24.2
1000 -----	L	101-128	137-161	9.5-11	17.1-19.4
	T	113-133	154-162	8.5-11.5	19.6-21.6

^a 10 specimens of each orientation were tested at room temperature and 5 specimens of each orientation were tested at each of the elevated temperatures. The data show the spread in results.

L = longitudinal; T = transverse.

TABLE 41.—Elevated Temperature Tensile Properties of 0.250-Inch Plate of 300-Grade Maraging Steel Heat D^a

[From ref. 143]

Testing temperature, °F	Specimen orientation	Yield strength 0.2 percent offset, ksi	Tensile strength, ksi	Elongation in 2 inches, percent	Elastic modulus, 10 ⁶ psi
75 -----	L	289-300	298-306	6-8	25.4-26.7
	T	269-294	279-304	6-8	25.6-29.2
300 -----	L	267-270	275-278	7.0	22.9-24.9
	T	254-274	263-279	6.5-7.0	24.3-28.2
600 -----	L	246-254	254-264	7.0-7.5	24.4-26.3
	T	226-249	236-258	6-7	21.6-26.1
800 -----	L	222-228	233-241	7.0	22.1-23.7
	T	210-224	227-242	6-7	21.6-25.2
1000 -----	L	164-168	191-196	9-10	18.9-21.5
	T	160-189	191-208	6-10	17.1-23.1

^a 10 specimens of each orientation were tested at room temperature and 5 specimens of each orientation were tested at each of the elevated temperatures. The data show the spread in results.
L=longitudinal; T=transverse.

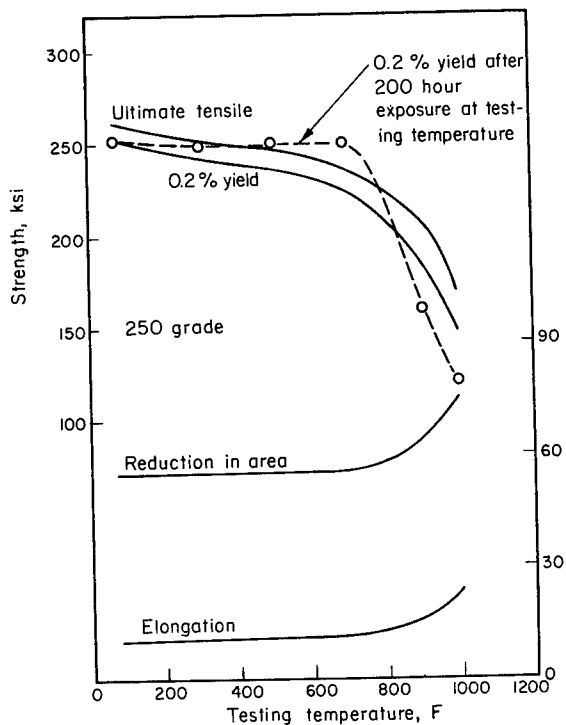

FIGURE 72.—Effect of testing temperature on the tensile properties of 250-grade maraging steel after solution annealing at 1500° F for 30 minutes and aging at 900° F for 3 hours (ref. 141; courtesy Vanadium-Alloys Steel Co.).

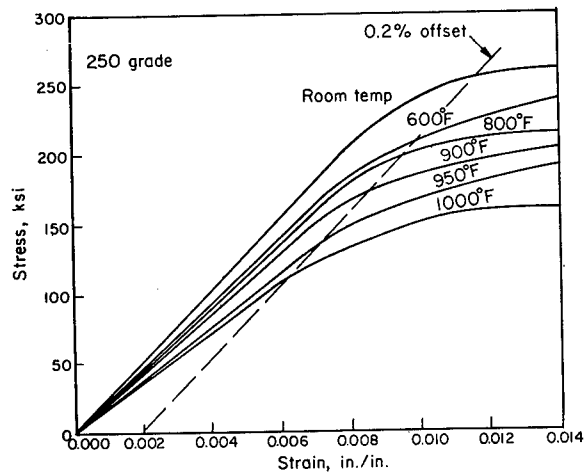

FIGURE 73.—Typical stress-strain curves for tensile specimens of 250-grade maraging steel tested at room temperature and elevated temperatures (ref. 141; courtesy Vanadium-Alloys Steel Co.). Condition: Solution annealed at 1500° F for 30 minutes, aged at 900° F for 3 hours.

dynamic modulus are nearly the same for the 250 and the 300 grades at each temperature level.

CREEP PROPERTIES

Maraging steels usually are not intended for use for extended time periods at elevated

TABLE 42.—*Low-Temperature Tensile Properties of 0.025-Inch Sheet of 250-Grade Maraging Steel*^a

[From ref. 145]

Testing temperature, °F	Specimen orientation	Yield strength 0.2 percent offset, ksi	Tensile strength, ksi	Elongation, percent	Elastic modulus, 10 ⁶ psi
75 -----	L	277	283	3.9	25.7
	T	277	285	3.1	25.4
-100 -----	L	293	304	1.6	26.1
	T	302	311	1.9	26.6
-320 -----	L	336	351	1.1	28.1
	T	341	356	1.3	27.7
-423 -----	L	386	397	1.1	28.7
	T	388	398	0.9	27.9

^a Average data for 5 specimens at each temperature and each orientation. Heat C56858. Specimens aged at 900° F for 3 hr. This composition is on the borderline between the 250 and 300 grades.

L=longitudinal; T=transverse.

temperatures. However, if such applications are considered, creep data are needed to estimate the extent of creep deformation at specific temperatures and time intervals. Creep data for specimens of 250 and 300 grades of maraging steel tested at 600° F are presented in figures 74 and 75 (ref. 143). The same reference also contains creep data for 800° F exposure.

FATIGUE PROPERTIES

The fatigue properties of maraging steels as reported by various sources have shown considerable variation depending on the methods used to make the fatigue tests. Apparently the mode of stressing and the surface conditions are particularly critical in determining the resistance to fatigue failure of these alloys. Typical S-N curves for rotating beam specimens of several grades of maraging steel are shown in figure 76 (ref. 147). These data indicate that the endurance limit has not been reached for the smooth specimens at 10⁸ cycles. Furthermore, the maximum fatigue stress for an average life of 10⁷ cycles or 10⁸ cycles is only slightly higher for the 300-grade than for the 200-grade maraging steel. This same trend is shown for notched bars.

Data for rotating beam tests from another source are shown in figure 77 (ref. 148). In this figure the stress scale represents the normalized stress (maximum fiber stress on fatigue loading/ultimate tensile strength). Data for different heats, different aging treatments, and different cyclic rates are shown for the 250 and 300 grades in the two graphs of figure 77. In the stress range for 10⁴ to 10⁵ cycles for failure the variations do not show significant trends for smooth specimens. However, other data from the same source indicate that underaging or overaging can cause substantial reductions in fatigue lives for notched specimens.

S-N curves for axial loading of sheet specimens from the longitudinal and transverse orientations and for different stress ratios are shown in figures 78 and 79 for 250-grade maraging steel. As shown, failure did not occur in 10⁷ cycles at stresses in the range from 40 000 to 50 000 psi on these tests. Results of tests on similar specimens at 600° and 800° F are shown in figure 80 for 250-grade and in figure 81 for 300-grade maraging steel. These data indicate that at the lower stress levels, the lives of the specimens tested at elevated temperatures were longer than for corresponding specimens tested at room temperature.

TABLE 43.—Elevated Temperature Compressive Properties of 0.070-Inch Sheet and 1.5-Inch-Diameter Bar of 250-Grade Maraging Steel Heat A^a

[From ref. 143]

Testing temperature, °F	Specimen orientation	0.070-inch sheet		1.5-inch-diameter bar	
		Compressive yield strength 0.2 percent offset, ksi	Compressive modulus 10 ⁶ psi	Compressive yield strength 0.2 percent offset, ksi	Compressive modulus, 10 ⁶ psi
75 -----	L	254-264	27.0-28.9	264-267	27.4-28.7
	T	230-254	29.4-31.7		
300 -----	L	214-224	26.7-28.6	238-242	24.9-27.4
	T	224-234	27.7-30.4		
600 -----	L	196-204	23.4-26.4	223-226	24.8-26.4
	T	201-215	26.0-29.1		
800 -----	L	181-195	22.3-24.1	209-214	22.6-24.6
	T	194-204	25.0-28.2		
1000 -----	L	162-163	22.8-24.4	170-173	20.2-22.5
	T	147-163	22.3-25.2		

^a 10 specimens of each orientation were tested at room temperature and 5 specimens of each orientation were tested at each of the elevated temperatures. The data show the spread in results. Elevated temperature tensile data for this same material are shown in table 40. Condition: solution annealed at 1500° F, aged at 900° F for 3 hr.

L=longitudinal; T=transverse.

TABLE 44.—Yield Strength Ratios for Compressive Tests of Maraging Steels

[From ref. 146]

Form	Grade	Orientation	Compressive yield strength
			Tensile yield strength
Sheet -----	250	Longitudinal -----	$\frac{247,000}{252,000} = 0.98$
	^a 250	Transverse -----	$\frac{296,000}{289,000} = 1.02$
Plate -----	250	Longitudinal -----	$\frac{247,000}{230,000} = 1.07$
	250	Transverse -----	$\frac{248,000}{228,000} = 1.09$
Bar -----	300	Longitudinal -----	$\frac{287,000}{272,000} = 1.06$
Bar -----	300	Longitudinal -----	$\frac{289,000}{272,000} = 1.06$

^a This heat was designated 250 grade, but its properties are more like 300 grade. Condition: Specimens aged at 900° F for 3 hr.

TABLE 45.—*Dynamic Modulus of Elasticity at Room and Elevated Temperatures for 250-Grade and 300-Grade Maraging Steel*

[From ref. 143]

Form	Specimen orientation	Testing temperature, °F	Dynamic modulus, 10 ⁶ psi	
			250 grade ^a	300 grade ^b
Sheet, 0.070 in.	Longitudinal -----	75	26.9	27.2
		300	26.1	26.3
		600	24.8	24.9
		800	23.7	23.4
		1000	22.3	22.3
Sheet, 0.070 in.	Transverse -----	75	26.5	26.6
		300	25.8	25.8
		600	24.4	24.5
		800	23.3	23.5
		1000	22.1	22.4
Plate, 0.250 in.	Longitudinal -----	75	25.9	26.3
		300	25.0	25.4
		600	23.7	24.0
		800	22.6	23.0
		1000	21.5	21.8
Plate, 0.250 in.	Transverse -----	75	26.5	26.4
		300	25.9	25.4
		600	25.0	24.2
		800	24.0	23.2
		1000	22.8	22.0
Bar, 7/8-in. diameter	Longitudinal -----	75	25.5	26.4
		300	24.6	25.5
		600	23.2	24.1
		800	22.2	23.2
		1000	20.8	21.8

^a Heat A, see table 40.

^b Heat D, see table 41.

CHARPY V-NOTCH IMPACT PROPERTIES

Effect of low and elevated temperatures on the Charpy V-notch impact energy of 200-, 250-, and 300-grade maraging steels is shown in figure 82. Data for different heats are likely to show some scatter at each testing temperature, because the toughness of these alloys is influenced by a number of melting and mill processing variables.

FRACTURE TOUGHNESS

Fracture toughness of maraging steels, for both parent metal and welds, has been studied on a number of programs in the past 4 years. However, there have been no

recognized standard methods for making plane-strain fracture-toughness tests. Consequently, various methods have been used in different laboratories and there is a high degree of scatter in the data. ASTM Committee E24 has recently completed a round-robin program to evaluate a recommended practice for plane-strain fracture-toughness testing using notched and precracked bend specimens. The NASA Lewis Research Center was responsible for a large part of the development work required for arriving at a recommended specimen design as well as producing the original draft of the recommended practice. Recommended practices for other procedures for fracture-toughness

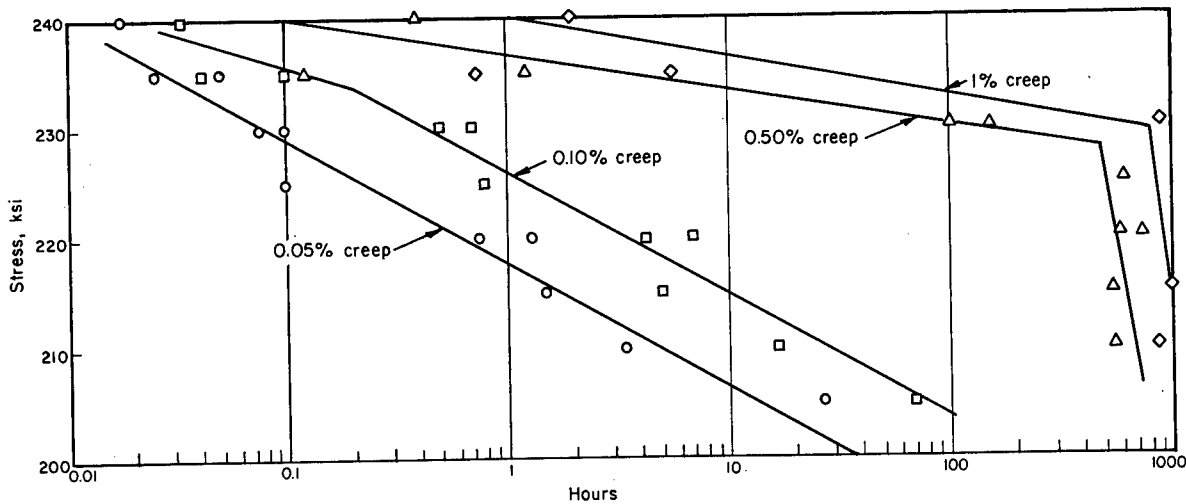

FIGURE 74.—Results of creep tests at 600° F on specimens of 250-grade maraging steel (ref. 143). Condition: Aged at 900° F for 3 hours. Transverse specimens of 0.070-inch sheet. See table 40 for tensile properties of this heat (heat A).

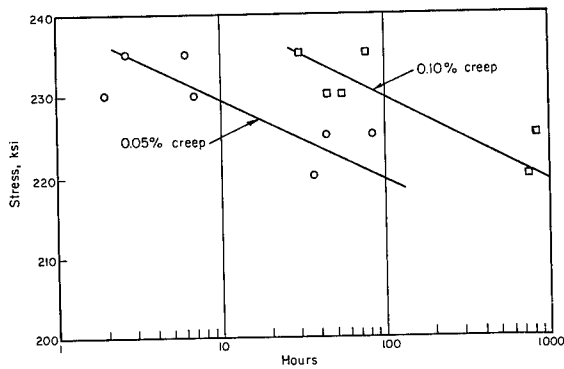

FIGURE 75.—Results of creep tests at 600° F on specimens of 300-grade maraging steel (ref. 143). Condition: Aged at 900° F for 3 hours. Transverse specimens of 0.070-inch sheet. See table 41 for tensile properties of this heat (heat D).

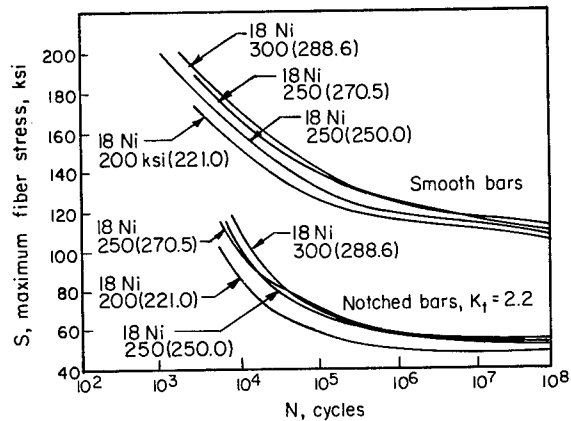

FIGURE 76.—S-N curves for rotating-beam fatigue specimens of maraging steels (ref. 147). Condition: Solution annealed at 1500° F for 1 hour, aged at 900° F for 3 hours. Numbers in parentheses are tensile strengths in ksi.

testing also are being developed. Until these practices are approved for standards, it will be necessary to refer to the best estimates for plane-strain fracture toughness of those alloys that have been evaluated. Best-estimate values for maraging steel plate are shown in table 46 (refs. 149 and 150). The key to specimen and notch orientations for these specimens is in figure 83. It should be pointed out that the melting

practice, amount of reduction, finishing temperature, and other mill practices have a pronounced effect on the fracture toughness of the maraging steels. The trend, however, is for the fracture toughness to decrease as the strength level is increased, as is the case for the VM or VAR heats in table 46. Additional data on fracture toughness of maraging steels has been reported by Aerojet-General Corp. (ref. 151).

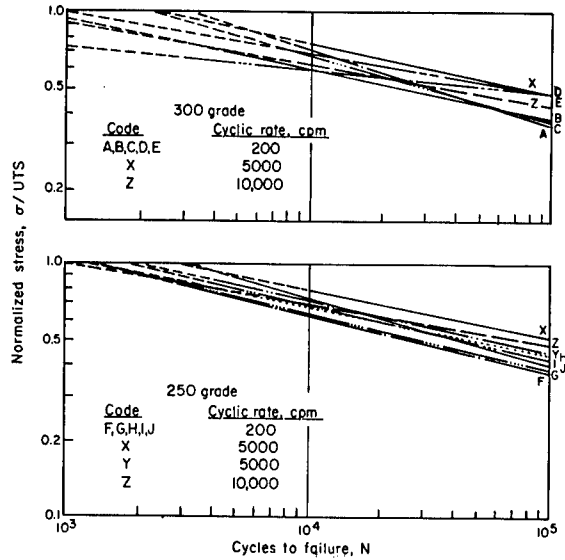

FIGURE 77.—Normalized stress versus number of cycles to failure for rotating-beam fatigue specimens of 300- and 250-grade maraging steels (ref. 148). Letter codes refer to different heats and different aging treatments.

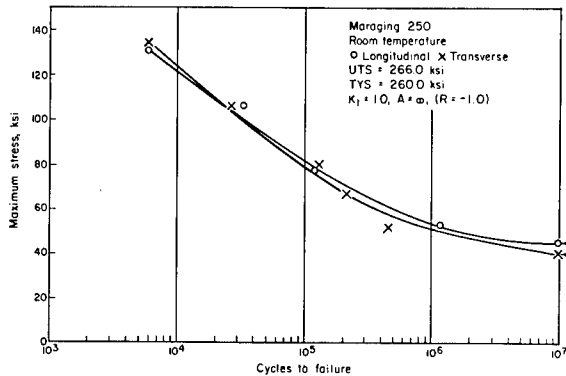

FIGURE 78.—S-N curves for axial loading of specimens of 0.070-inch sheet of 250-grade maraging steel with stress ratio $A = \infty$ ($R = -1$) (ref. 143). Condition: Aged at 900° F for 3 hours and air cooled.

The purpose in obtaining plane-strain fracture-toughness data is that the numbers (K_{Ic} values) can be used in fracture mechanics equations to estimate the critical crack sizes for catastrophic failures at specified stress levels. This is significant, because most failures of high-strength components are initiated at small cracks which had not

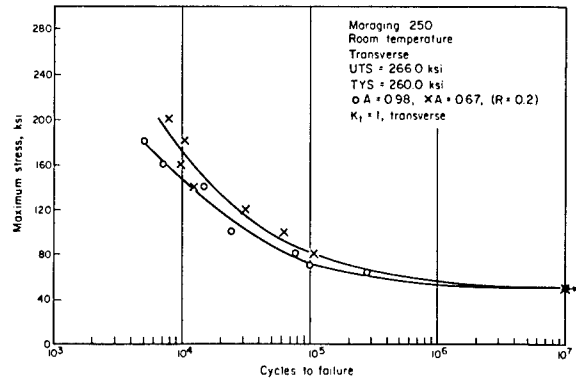

FIGURE 79.—S-N curves for axial loading of specimens of 0.070-inch sheet of 250-grade maraging steel with stress ratios of $A = 0.98$ and $A = 0.67$ ($R = 0.2$) (ref. 143). Condition: Aged at 900° F for 3 hours and air cooled.

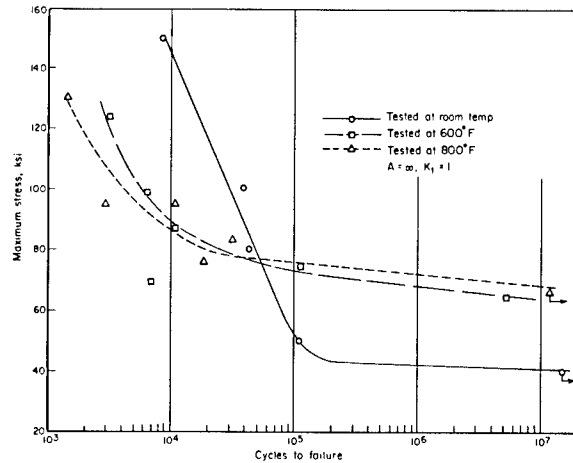

FIGURE 80.—S-N curves for cyclic-tension loading of 0.070-inch-sheet specimens of 300-grade maraging steel, heat D (ref. 143). Condition: Aged at 900° F for 3 hours.

been detected in the structures. This was the cause of the premature failure in a 260-inch-diameter motor case which had been fabricated of maraging steel (ref. 152).

For relatively thin material, fracturing at flaws often occurs according to a plane-stress mode which cannot be accurately analyzed by fracture mechanics procedures. However, prototype pressure vessels may be fabricated and pressure tested. Before pressure testing, a small flaw may be pro-

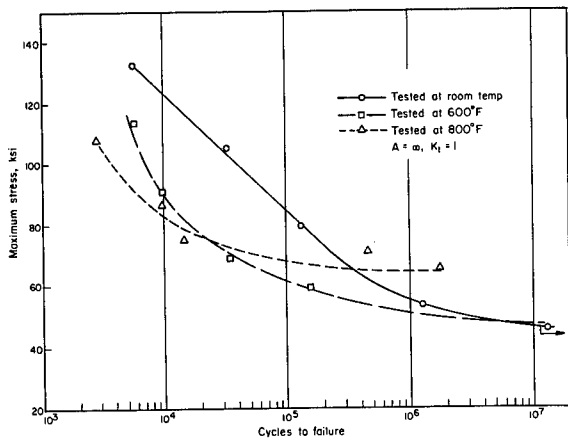

FIGURE 81.—S-N curves for cyclic-tension loading of 0.070-inch-sheet specimens of 250-grade maraging steel, heat A (ref. 143). Condition: Aged at 900° F for 3 hours and tested at room temperature, 600° F, and 800° F.

duced in the wall of each pressure vessel. In cylindrical pressure vessels, these flaws should be halfway between the ends of the vessel and oriented in the longitudinal direction. Data from one series of tests are shown in figure 84 (ref. 153). This kind of information is important in evaluating materials for small tactical missile motor cases. In addition, it establishes the lower limit of flaw size for detection by nondestructive testing methods.

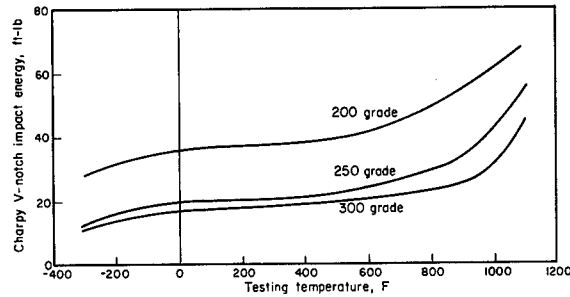

FIGURE 82.—Charpy-impact energy curves indicating the effect of low and elevated temperatures on the impact energy (ref. 141, courtesy Vanadium-Alloys Steel Co.).

Unpublished data from Lewis Research Center indicate that vacuum-melted maraging steel of 250 grade has substantially better fracture toughness than air-melted material. Double-vacuum melting did not result in any further improvement in toughness over the single-vacuum-melted product. The tests were made at -110° F in an attempt to obtain plane-strain fracturing, as the specimens were not large enough for valid K_{Ic} data at room temperature. Limited fracture-toughness data obtained at room temperature also indicate that vacuum-melted maraging steel has better fracture toughness than air-melted material of 250

TABLE 46.—Representative Plane-Strain Fracture-Toughness Data for Notched and Pre-cracked Bend Specimens of Maraging Steel ^a

[Refs. 149 and 150]

Grade ^b	Yield strength, ksi	Tensile strength, ksi	Specimen and notch orientation ^c	Specimen dimensions		Best estimate for K_{Ic} , ksi √in.	Reference
				Thickness, inches	Width, inches		
200 (AM) ----	193	200	RW	2	4	105	149
200 (VM) ----	187	195	RW	2	4	160	149
250 (VM) ----	246	257	RW	2	4	87	149
250 (VAR) ---	242	-----	WR	0.45	1, 2	84.5	150
250 (VAR) ---	259	-----	RW	0.50	1, 2	68	150
300 (VAR) ---	285	-----	RW, RT	0.25-1.0	1, 2	52	150

^a Data are for 4-point bending tests on notched and precracked specimens at room temperature.

^b AM=air melted; VM=vacuum melted; VAR=vacuum arc remelted.

^c See fig. 82.

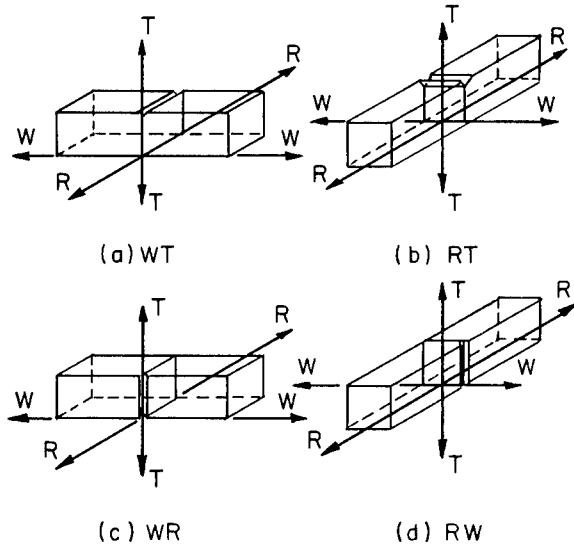

FIGURE 83.—Crack-propagation directions.
 R=rolling direction
 W=width direction
 T=thickness direction

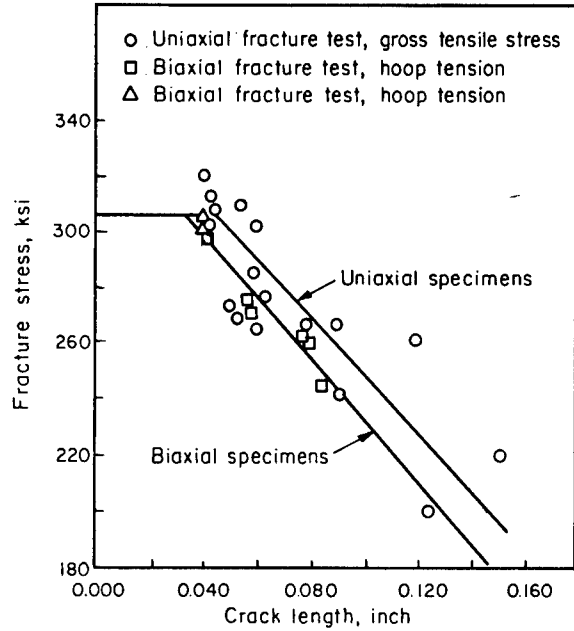

FIGURE 84.—Fracture stress versus crack length for precracked-tension specimens and pressure vessels of 250-grade maraging steel, cold rolled and aged to 305 000-psi yield strength (ref. 153).

TABLE 47.—Shear Strengths and Shear Strength/Tensile Strength Ratios for Maraging Steels

[From ref. 146]

Form	Grade	Orientation	Shear strength Tensile strength ratios
Sheet -----	250	Longitudinal -----	$\frac{143,000}{262,000} = 0.55$
Plate -----	250	Longitudinal -----	$\frac{143,000}{240,000} = 0.60$
		Transverse -----	$\frac{143,000}{236,000} = 0.61$
Bar (1/4 in. D) -----	250	Longitudinal -----	$\frac{149,000}{264,000} = 0.56$
	300	Longitudinal -----	$\frac{167,000}{302,000} = 0.55$
Bar -----	300	Longitudinal -----	$\frac{163,000}{281,000} = 0.58$
	300	Longitudinal -----	$\frac{162,000}{282,000} = 0.58$

grade. Preliminary data indicate that high-purity base maraging steel of 250 grade also has improved toughness compared with that expected for air-melted material.

SHEAR STRENGTH AND BEARING STRENGTH

Data for shear strengths and shear strength/tensile strength ratios for several

forms and grades of maraging steel are shown in table 47. For these data, the ratios are from 0.55 to 0.61 for the 250 and 300 grades.

Data for bearing strengths and bearing yield strengths and the corresponding bearing/tensile ratios for 300-grade maraging steel are shown in table 48.

TABLE 48.—Bearing Strength and Bearing Strength/Tensile Strength Ratios for 300-Grade Maraging Steel

[From ref. 146]

	Heat 06989	Heat 07081
$\frac{\text{Bearing strength } (e/D=1.5), \text{ psi}}{\text{Tensile strength, psi}}$	$\frac{391,000}{281,000} = 1.39$	$\frac{402,000}{282,000} = 1.43$
$\frac{\text{Bearing strength } (e/D=2), \text{ psi}}{\text{Tensile strength, psi}}$	$\frac{500,000}{281,000} = 1.78$	$\frac{513,000}{282,000} = 1.82$
$\frac{\text{Bearing yield strength } (e/D=1.5), \text{ psi}}{\text{Tensile yield strength, psi}}$	$\frac{382,000}{272,000} = 1.40$	$\frac{372,000}{272,000} = 1.37$
$\frac{\text{Bearing yield strength } (e/D=2), \text{ psi}}{\text{Tensile yield strength, psi}}$	$\frac{474,000}{272,000} = 1.75$	$\frac{431,000}{272,000} = 1.58$

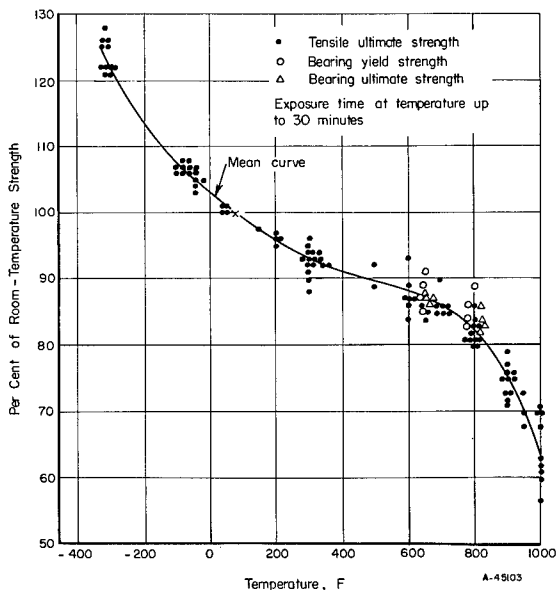

FIGURE 85.—Effect of temperature on the ultimate tensile strength for bearing yield, and ultimate bearing strength of maraging steels aged at 900° F for 3 hours (ref. 146).

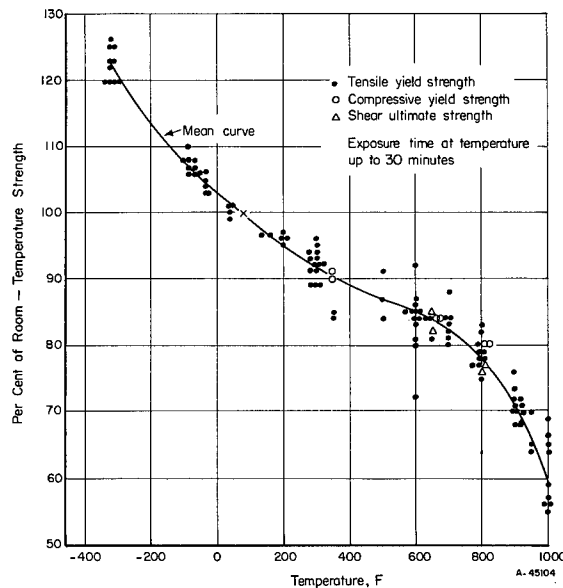

FIGURE 86.—Effect of temperature on the tensile yield strength, compressive yield strength, and ultimate shear strength of 18 percent nickel maraging steels aged at 900° F for 3 hours (ref. 146).

TABLE 49.—*Thermal Conductivity and Specific Heat of 250- and 300-Grade Maraging Steel Aged at 900° F For 3 Hr*

[From ref 143]

Grade	Testing temperature, °F	Thermal conductivity, Btu/(hr) (ft) (F)	Specific heat Btu/(lb) (°F)
250	75	14.6	0.069
	300	16.2	0.107
	600	17.6	0.149
	800	17.8	0.338
300	75	14.6	0.086
	300	16.2	0.115
	600	17.6	0.143
	800	17.8	0.205

TABLE 50.—*Mean Thermal Expansion Coefficient for 250- and 300-Grade Maraging Steel Aged at 900° F For 3 Hr*

[From ref. 143]

Temperature range, °F	Mean thermal expansion coefficient 10 ⁻⁶ in./in./°F	
	250 grade	300 grade
75-200	5.6	4.8
75-300	5.8	5.3
75-400	5.8	5.4
75-500	5.8	5.4
75-600	5.7	5.5
75-700	5.6	5.6
75-800	5.6	5.6

TABLE 51.—*Physical and Electrical Properties of Maraging Steel*

[From ref. 141]

	250 grade	350 grade
Density, lb/cu in. ----	0.289	0.292
Modulus of elasticity, 10 ⁶ psi -----	26.5	27.0
Modulus of rigidity (torsion), 10 ⁶ psi --	10.2	
Poisson's ratio -----	0.30	
Coefficient of expansion, 10 ⁻⁶ in./in./°F -----	5.6	6.3
Change in length on maraging, in./in. ----	-0.0004	(70°-900° F)
Electrical resistivity, μohm-cm:		
Solution annealed ----	60-61	
Maraged -----	38-39	
Intrinsic induction, gauss:		
When H = 250 oersteds -----	16 500	
When H = 5000 oersteds -----	18 550	
Remanence, gauss ----	5 500	
Coercive force, oersteds	28.1	

The effect of low temperatures and elevated temperatures on tensile, compressive, shear, and bearing properties is shown in figures 85 and 86.

PHYSICAL PROPERTIES

Thermal conductivity, specific heat, and thermal expansion data for 250-grade and 300-grade maraging steel are presented in tables 49 and 50. Other physical and electrical properties are noted in table 51.

Corrosion, Stress Corrosion, and Related Properties

High strength and toughness have been emphasized in many uses of the 18-percent nickel maraging steels. However, retention of these properties and prevention of failure in certain environments must also be considered as major requirements. Almost any environment may cause some form of deterioration in metals and alloys. Such deterioration may range from mild to severe, depending on the material and the conditions. In the case of maraging steels and other high-strength steels, stress corrosion, hydrogen embrittlement, and corrosion fatigue may seriously reduce the load-carrying capabilities of the steels. Ordinary corrosion of unstressed material is less harmful because it proceeds at a relatively slow rate in most natural environments. Corrosion under stress, however, may lead to failure by stress-corrosion cracking (SCC) which is a much more serious situation. Similarly, the accumulation of hydrogen in stressed maraging steel may result in a brittle fracture that is referred to as hydrogen-stress cracking (HSC). Furthermore, the combination of corrosion and cyclic stress can result in failure by corrosion fatigue. More details about these failure mechanisms are given in later sections.

Many factors that affect the behavior of maraging steels in corrosive environments have been studied extensively. The ones pertaining to the metal include melting practice, heat treatment, composition, structure, mechanical properties (particularly strength and toughness), and the kind of fabricating procedures used in manufac-

turing. Variables in test procedures include the nature of the environment, period of exposure, type of test specimen, level of applied stresses, and method of applying stresses to the specimens. In hydrogen-stress cracking investigations, the effect of the hydrogen content in the metal and various means for charging the metal with hydrogen have both been studied.

In this chapter, the results of studies on the numerous factors mentioned above are reviewed and summarized. It is not possible in all cases to compare the results of different investigations quantitatively because of differences in the test procedures that have been used. In comparable investigations, however, valid conclusions on the effects of metal variables may be reached.

GENERAL CORROSION

Maraging steels are not stainless. Consequently they may be expected to corrode in aggressive environments. Relatively little quantitative data have been reported on the corrosion of maraging steels in natural environments. This is probably because it is taken for granted that the steel will rust; therefore protective coatings may be needed just as with ordinary steels. Also, since the maraging steels are relatively new, long-range tests, if any, are still in progress for the commercial 18-percent nickel series. Results of 1-year exposure in an industrial and a marine atmosphere have been reported (ref. 154). They are summarized in table 52. The four 18-percent nickel alloys tested are representative of the 200, 250, and 300

grades, the first two being air melted and the other two being consumable-electrode, vacuum-arc-remelted heats. The low-alloy steels AISI 4340 and HY-80, included for comparison, had yield strengths of 240 ksi and 96 ksi, respectively. Results of total immersion tests in quiet sea water at Harbor Island, N.C., are also included in table 52 (ref. 154). The corrosion rates in mils per year (mpy) were calculated from the weight losses determined after the corrosion products were removed. Thus, they are average values for metal wastage over the whole surfaces and do not indicate the depth of pitting. The depths of the 10 deepest pits on each panel exposed to the industrial atmosphere at Bayonne were measured and the average recorded in the table.

It appears that the corrosion rates for all four maraging steels were about the same in either the industrial or marine atmospheres, but they corroded at only about half the rate of the low-alloy steels. Maraging steels also had shallower pitting. In the Bayonne atmosphere the average corrosion rates of all the alloys decreased substantially during exposure because of the development of a protective rust scale. In quiet sea water the maraging steels corroded at a rate of about 3 mpy, somewhat less than the rate observed for the low-alloy steels. In flowing sea water the maraging steels were reported to corrode at 5 to 7 mpy (ref. 155).

The maraging steels also corrode substantially in tap water, some neutral salt solutions and in some inorganic and organic acids. Therefore, the steels should be protected by suitable coatings when used in such environments. Conventional cathodic protection is not recommended because of the danger of hydrogen embrittlement (ref. 155).

STRESS-CORROSION CRACKING AND HYDROGEN-STRESS CRACKING

The behavior of maraging steels in stressed components exposed to corrosive environments, or to environments that introduce hydrogen into the metal, has been of considerable concern to the aerospace industry. This is because the steels are used at

high-strength levels where they are more susceptible to sudden catastrophic fracture by stress-corrosion cracking or by delayed brittle fracture induced by hydrogen.

Maraging steels are attractive for applications such as large rocket-motor cases, hulls for deep submersible vessels, autoclaves, and similar pressure vessels where high strength, toughness, and light weight are of paramount importance. This has stimulated numerous investigations to evaluate the susceptibility of maraging steels to such cracking, and to establish their limits of usefulness. It is of interest, first to consider the characteristics and mechanism of stress-corrosion cracking and hydrogen-stress cracking, to place these phenomena in proper perspective in relation to the possible uses for the steels.

Characteristics of Cracking

Stress-corrosion cracking and hydrogen-stress cracking are similar in some respects, although the basic mechanisms of fracture may be different. The similarities and differences have been discussed in two recent reports (refs. 156 and 157). It appears likely that, under some circumstances, both types of cracking occur simultaneously. Both types of cracking are affected by some of the same factors. The important ones are strength level, composition and structure of the steel, applied and residual stresses, environment, and time (ref. 157).

It is generally accepted that SCC is caused by the combined effects of corrosion and static tensile stresses at the metal surface. Neither the stresses, or corrosion acting separately, will cause the cracking. Fracture occurs in a brittle manner even though the material is ductile in the ordinary sense. Furthermore, failure occurs at a stress level that is sometimes considerably below the yield strength of the material. Usually there is little general corrosion of the metal surface and no macroscopic evidence of impending failure (ref. 158). In some cases, applied stresses merely accelerate general corrosion and the metal does not fail unless the entire cross section has been reduced to

TABLE 52.—Corrosion Rates of Commercially Produced Alloys

[From ref. 154]

Alloy type	Bayonne atmosphere						Kure Beach atmosphere						Sea water		
	Corrosive rate, mpy ^a (months)			Pit depth, mils (months)			800-ft lot, mpy ^a (months)			80-ft lot, mpy ^a (months)			Corrosion rate, mpy ^a (months)		
	3	6	12	3	6	12	3	6	12	3	6	12	3	6	12
18 percent Ni -----	1.2	0.86	0.50	1.1	2.5	3.1	0.35	0.45	0.42	0.70	0.65	0.64	3.2	2.3	2.6
	1.2	.91	.52	1.4	2.5	3.0	.40	.45	.38	.65	.70	.56	3.0	2.5	2.8
	1.4	.84	.50	2.0	2.1	2.3	.55	.50	.42	.75	.65	.60	2.8	2.4	2.4
	1.6	.89	.51	2.0	2.2	2.5	.45	.50	.40	.70	.60	.53	3.0	2.6	2.0
4340 -----	2.8	1.82	.80	4.7	5.2	5.0	1.65	1.25	.92	2.30	1.50	1.34	3.1	2.8	4.3
HY-80 -----	3.0	1.77	.88	5.1	5.6	4.5	1.50	1.15	1.02	2.40	1.50	1.41	2.8	2.6	3.3

^a mpy = mils per year.

the point where it is no longer able to withstand the applied stress mechanically. This is not stress-corrosion cracking. In contrast, the corrosion in a material that is susceptible to stress-corrosion cracking is concentrated in deep, narrow pits, so that very little total corrosion occurs before failure takes place. The sequence of events in the stress-corrosion cracking of smooth metallic parts of high-strength structural alloys is thought to be as follows (ref. 159):

(1) The surface of the metal slowly becomes pitted or roughened by nonuniform corrosion.

(2) When a surface irregularity such as a pit attains sufficient depth and acuity, a stress-corrosion crack initiates and grows.

(3) When this crack attains a critical size, the remaining ligament ruptures by purely mechanical fracture, provided the stress has not been relaxed.

Not all alloys corrode or pit as indicated in step (1), so that the mechanism of the development of a nucleus for propagation of a crack may differ. For example, a manufacturing defect or flaw may serve as the origin of a stress-corrosion crack.

There is considerable evidence that SCC results from stress-induced electrochemical corrosion of a metal in contact with an electrolyte. That is, the propagation of a crack depends on the flow of current between localized anodic and cathodic areas (ref. 159). According to one theory, the plastic yielding at the advancing edge of a crack stimulates the anodic reaction there, causing the metal to go into solution more rapidly than at the sides of the crack. This accounts for the rapid propagation of the crack into the metal with little or no evidence of corrosion products. To complete the electrolytic cell circuit, electrons are released into the metal through which they flow to a cathodic area in the metal where they participate in a reduction reaction.

This mechanism has been verified for some high-strength alloys by experiments showing that the time to fracture could be greatly extended by polarizing the cathodic areas to a potential approaching that of the

anodic areas. Extremely low current flow is sufficient for this. If higher current densities are used excess hydrogen is formed and failure then may occur by the related mechanism of hydrogen-stress cracking described below.

Hydrogen-induced delayed brittle fracture occurs as a result of the presence of atomic hydrogen in the metal in combination with tensile stresses. Before hydrogen-stress cracking can occur a critical combination of stress and hydrogen content must exist in a susceptible material and at a location suitable for crack nucleation (ref. 157). This type of cracking cannot occur if hydrogen is prevented from entering the steel, or if any hydrogen that does enter is eliminated before permanent damage has occurred. The source of the hydrogen is of little importance. It can be introduced, for example, during cleaning, pickling, or electroplating operations. If the material is exposed to a corrosive environment a corrosion reaction could provide the necessary hydrogen for stress cracking. However, if the corrosion is taking place at the tip of a rapidly advancing crack, as described above for SCC, it might be difficult to decide whether fracture was caused by SCC or HSC.

In contrast to the results of cathodic polarization tests described for SCC, imposing a cathodic current on a specimen that is susceptible to HSC will cause the specimen to fail more quickly because of the additional hydrogen that is supplied, whereas imposing an anodic current will extend its life (unless the material is also susceptible to stress-corrosion cracking).

As summarized in reference 157, both fracture mechanisms are promoted by higher stress levels, both require tensile stresses, both seem to involve a nucleation period and the fracture modes are generally intergranular, although transgranular cracking also has been reported. Also, failures occur at stress levels considerably below the design stresses. Yet HSC is promoted by cathodic conditions whereas SCC is promoted by anodic conditions. In addition, HSC is more likely to occur near room tem-

perature, whereas failures by SCC are likely to be accelerated at higher temperature.

The above discussion may appear to be somewhat disparaging about the ability of maraging steels to survive under highly stressed conditions. Such is not the case because, as will be seen in the following sections, the maraging steels are considerably more resistant to SCC and HSC than most other martensitic steels at similar strength levels. Also, as a result of the knowledge gained in numerous investigations, it is possible to specify the treatments and conditions that are likely to provide the optimum resistance to brittle fracture.

Results of Stress-Corrosion-Cracking Investigations

In the evaluation of the SCC susceptibility of any material the most realistic, quantitative data would, of course, be obtained by field tests. That is, exposure of the full-scale parts in the actual service environments and observing their performance over the life of the products. This is obviously not practical in instances where it is desired to determine the effect of the many processing and material factors within reasonable periods of time. Therefore, one must resort to laboratory tests. These are sometimes designed to simulate the natural exposure conditions. In other procedures, the conditions are made more aggressive in order to obtain results within shorter periods of time. It is also common practice to expose laboratory test specimens to the desired natural environments, but usually more exposure time is necessary to get results. The design of corrosion experiments thus becomes quite complicated, and interpretation of the results even more so. The use of laboratory test results to predict the performance in the field must be done very carefully only after sufficient data have been accumulated and correlated.

The most common use of laboratory data is for comparative purposes. For example, the behavior of different alloys subjected to the same stress-corrosion-cracking test procedure may be compared. The effect of

various heat treatments or other processing variables on the SCC behavior under laboratory test conditions may be examined and compared.

In the case of maraging steels, an appreciable number of investigations were concerned with an assessment of SCC life in salt-water environments. Stressed specimens have been exposed to 3, 3½, and 5 percent aqueous sodium-chloride solutions, either by continuous immersion or by alternate wetting and drying cycles. Other tests have been made in quiet sea water, flowing sea water, and synthetic sea water. Exposure tests in seacoast atmospheres have also been conducted. In comparing results it should be remembered that these saline environments are not equally corrosive. The need for information on the SCC susceptibility of maraging steels in environments encountered during the manufacture, hydrotesting, and storage of rocket-motor cases prompted the investigation of such environments in other laboratory tests (refs. 160 and 161).

Several methods for stressing the test specimens have been used. In the 2-, 3-, or 4-point loaded bent beam tests for sheet the specimen is bent elastically, and restrained in the stressed position while exposed to the corrosive environment. This stresses the outer fibers to a level usually below the 0.2-percent offset yield strength of the material. The time to failure, or nonfailure, is a measure of susceptibility to SCC. Another test procedure utilizes a specimen around a mandrel in a U-form, with the legs drawn together and held in position with a bolt. The deformation introduces both plastic and elastic strain in the outer fibers.

Some recent studies of SCC have used a notched-bar fatigue cracked specimen as a cantilever beam; i.e., loaded at one end (ref. 159). In this test, the cracked specimen is surrounded by a corroder and loaded at an initial stress intensity somewhat lower than that required to fracture the sample in air. Time for fracture is noted, and successively lower stress intensities are used in additional tests until one is reached that does

not cause crack propagation to failure within the period of the test. The data may be plotted to determine the threshold value of stress intensity, $K_{I_{SCC}}$, that is required to initiate SCC. Thus, using the concepts of fracture mechanics, stress-corrosion cracking is measured in terms of the stress intensity at the root of the crack, rather than by time to failure. The parameter K with appropriate subscripts is the same as that used to characterize fracture toughness. It has been emphasized, however (ref. 162), that there is no implied relationship between fracture toughness and SCC. The fact that $K_{I_{SCC}}$ is lower than the fracture toughness index $K_{I_{SCC}}$ merely means that SCC occurs at a lower level of stress intensity. It has been observed that, as the strength of the steel is increased by composition or processing changes, the fracture toughness decreases. In most cases the resistance to SCC also decreases, but not in any known relationship to the change in fracture toughness.

Melting Practice

Several evaluations and investigations of the maraging steels included a few tests on the effect of melting practice on the stress-corrosion behavior of the steels. The consensus seems to be that consumable-electrode, vacuum-arc remelting or vacuum-induction melting produces steel that is somewhat more resistant to SCC than air-melted steel. However, the improvement is relatively minor and, in some cases, no significant differences were reported. In an evaluation of closed-die forgings (ref. 163), the data summarized in table 53 show that VAR 18 Ni 250-grade steel is somewhat tougher than its air-melted counterpart, with little difference in SCC susceptibility. In this comparison round, unnotched specimens were used and only 3 specimens out of 32 failed during the period of the test. Perhaps a longer test period is needed to detect possible differences.

The specimens of 18 Ni 300-grade VAR steel, stressed to 75 percent of their tensile strength, withstood 333 hours of alternate

immersion in 5.0 NaCl without failure. Three years earlier, specimens tested by the same procedure failed in times ranging from 4 to 12 hours. This large difference prompted a metallographic investigation which revealed bands of inclusions and significantly larger grain size in the latter specimens, probably accounting for the poorer performance. This emphasizes the importance of structure and homogeneity in the properties of the steel, and also points out the hazards of making comparisons of results obtained in different investigations.

In the same investigation an entirely different procedure was used to evaluate sheet material (ref. 163). Fatigue-precracked, center-notched specimens were stressed in tension while immersed in 3 percent sodium chloride. The results are summarized in table 54. The times to failure were very short and generally so nearly the same at comparable stress levels that no clear-cut distinctions can be made. On an overall basis, there appears to be a slight trend in favor of the VAR material.

Bent-beam stress-corrosion cracking tests that included both air-melted and vacuum-arc-remelted material were part of several other investigations. In the investigation reported in reference 154, specimens of 18 Ni 250 grade air melted and VAR material, similarly processed to 1/8-inch sheet, were stressed up to about 90 percent of the 0.2 percent offset yield strength and exposed to the industrial atmosphere at Bayonne, N.J., for 514 days, and to the marine atmosphere at Kure Beach for 491 days without failure. Thus, both melting practices produced material having very good resistance to SCC. In the same test, AISI 4340 steel at about the same strength level failed after 1 or 2 weeks' exposure to either environment. The same maraging steels stressed in the form of U-bends were immersed in flowing sea water for 490 days without failure.

An investigation of candidate hull materials for deep submergence applications (ref. 164) included one comparison of VAR versus AM material, as shown in the following tabulation. The specimens were

stressed to 90 percent of their yield strength and exposed (in triplicate) to flowing sea water:

Material	0.2 percent offset yield strength, ksi	Days to failure
18-9-5 VAR ---	286	26, 52
18-8-5 VAR ---	253	447, 447, 374
18-8-3 VAR ---	210	NC, ^a NC, NC ^a
18-8-3 AM ----	205	NC, NC, NC

^a Not cracked in 457 days, general surface attack.

The influence of melting practice in this test is shown only on the 200-grade maraging steel. Again, the resistance to SCC was so good that no distinction attributable to melting practice could be made. The surfaces of the specimens were covered with a tightly adherent, calcareous scale.

One other investigation reported on the influence of melt practice (ref. 165). In this case, vacuum-induction-melted and air-melted 200-grade maraging steel heats were tested. Face-notched, cantilever-beam test specimens were exposed in synthetic sea water at various loads to determine the K_{ISCC} values. The low-residual, vacuum-induction-melted 18 Ni-8 Co-3 Mo steel was found to have a critical stress-corrosion-cracking stress intensity value (K_{ISCC}) of 120 ksi $\sqrt{\text{in.}}$ in a 1000-hour test period. The K_{ISCC} value for the air-melted heat was 108 ksi $\sqrt{\text{in.}}$, indicating somewhat poorer resistance to stress-corrosion cracking. The vacuum-induction-melted material was also tougher, as shown by the plane-strain-stress-intensity factor K_{Ic} of 142 ksi $\sqrt{\text{in.}}$ against 118 ksi $\sqrt{\text{in.}}$ for the air-melted material. A comparison of the stress-corrosion resistance of the 18 Ni 200-grade steel and a 12 Ni-5 Cr-3 Mo is shown in figure 87 (ref. 165). The fracture-toughness index (measured in air) is noted on the curves. The results indicate that toughness is not necessarily a measure of SCC resistance when different steel compositions are compared. However, for each alloy, the

stress-corrosion resistance appears to increase with toughness.

Although quantitative comparisons of the reported results are not possible because of

TABLE 53.—Results of Stress-Corrosion Tests on 250- and 300-Grade Closed-Die Forgings^a

[From ref. 163]

18 percent Ni (300) VAR UTS 290 ksi, K_{Ic} 54.4 ksi $\sqrt{\text{in.}}$ ^b		
Applied stress		Time to failure, hr
ksi	Percent of UTS	
260	^c 90	^c 2/5 (85), 3NF (333)
218	^d 75	0/3 (333)
210	^e 72.5	3/8 (469), 5NF (~500)
18 percent Ni (250) VAR UTS 261.8 ksi, K_{Ic} 66.3 ksi $\sqrt{\text{in.}}$		
Applied stress		Time to failure, hr
ksi	Percent of UTS	
235	^c 90	^c 0/4 (400-577)
195	^d 75	0/4 (333)
195	^e 75	1/8 (433), 7NF (~500)
18 percent Ni (250) AM UTS 269.1 ksi, K_{Ic} 58.3 ksi $\sqrt{\text{in.}}$		
Applied stress		Time to failure, hr
ksi	Percent of UTS	
242	^c 90	^c 0/4 (~400)
200	^d 75	0/4 (338)
200	^e 75	2/8 (600), 6NF (~500)

^a Deadweight tension load, round unnotched specimens, short-transverse grains exposed.

^b Relative stress intensity factor.

^c 3½ percent NaCl, alternate immersion, 9 min wet, 51 min drying.

^d 5 percent NaCl, alternate immersion, 5 min wet, 15 min drying.

^e Ratio of number of specimens failed to number tested. NF=not failed. Numbers in parentheses are hours in test, or average hours to failure.

TABLE 54.—Results of Stress-Corrosion Tests on 250- and 300-Grade Sheet ^a

[From ref. 163]

VAR-300 grade:

0.045-in. sheet, YS 278.9 ksi, NTS/YS 0.53

0.160-in. sheet, YS 262.2 ksi, NTS/YS 0.72

Applied stress, percent of yield strength	Time to failure, hr	
	0.045-inch sheet	0.160-inch sheet
90 -----	25	17
80 -----	31.5	17
70 -----	43	28

VAR-250 grade:

0.045-in. sheet, YS 268.3 ksi, NTS/YS 0.72

0.160-in. sheet, YS 248.5 ksi, NTS/YS 0.73

Applied stress, percent of yield strength	Time to failure, hr	
	0.045-inch sheet	0.160-inch sheet
90 -----	^b 26	32
80 -----	33	38
70 -----	^c 36	^d NF 48

AM-250 grade:

0.045-in. sheet, YS 234.4 ksi, NTS/YS 0.77

0.160-in. sheet, YS 225.6 ksi, NTS/YS 0.84

Applied stress, percent of yield strength	Time to failure, hr	
	0.045-inch sheet	0.160-inch sheet
90 -----	0	<1
80 -----	24, 138	32
70 -----	46	45

^a Fatigue precracked center notched specimens, in tension, immersed in 3 percent NaCl. Tests in duplicate. Longitudinal direction.

^b 1 specimen; duplicate did not fail in 252 hours.

^c 1 specimen; duplicate did not fail in 48 hours.

^d NF=not failed.

the differences in test procedures, it appears that some improvement in resistance to stress-corrosion cracking may be expected in material that has been vacuum-induction melted or vacuum-arc remelted. This is,

no doubt, related to improved homogeneity and purity that are obtained by the latter methods. As discussed in chapter 4, the choice of melting practice is dependent on the properties required for specific applications, the grade of maraging steel, and possibly on cost factors. In some of the investigations just described, it appeared that the lower strength grades of maraging steels had very good resistance to SCC in marine and atmospheric environments, and air melting might be acceptable. For best results at very high applied stresses and where maximum toughness is required, vacuum-arc remelting should be advantageous. Also, VAR is preferable for the higher strength grades such as 18 Ni 300 and 18 Ni 350 grades.

Processing and Compositional Factors

Numerous reports have been written dealing with evaluation of maraging steels either for an intended application, or to determine the effect of processing or compositional changes on the properties of the steels. Usually the main interest has been on mechanical properties, but, in some instances, resistance to corrosive environments was also determined.

Some of the early investigations were undertaken to study the susceptibility to SCC of high-strength materials that were contemplated for use as rocket-motor case materials (refs. 160, 161, and 166). The behavior of maraging steels was tested in environments considered to be representative of those to which rocket-motor cases would normally be exposed during fabrication and storage. In these programs composition and processing of the maraging steels were varied to get 0.2 percent offset yield strengths ranging from 181 to 354 ksi. The main compositional variable that affected the strength was the titanium content, although the highest strengths were obtained by cold rolling 50 percent prior to aging. Some of the results are tabulated in table 55. These show that the susceptibility to stress-corrosion cracking increases as the strength of the metal is increased by

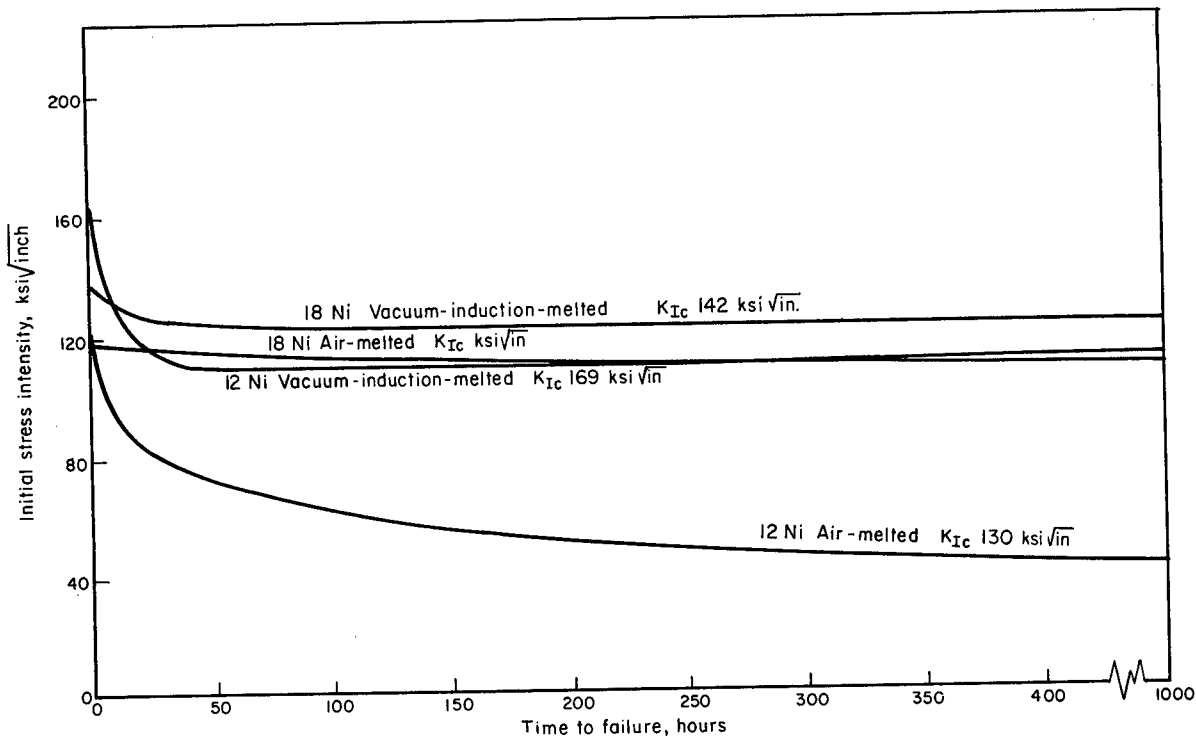

FIGURE 87.—Stress-corrosion resistance of 12 Ni and 18 Ni maraging steels (ref. 165).

compositional changes, although some inconsistent results are apparent. These may be caused by differences in primary processing of heats by various producers. The material that was strengthened by cold working prior to aging showed superior resistance at high-strength levels. This is probably because the cold rolling breaks up coarse grains and produces a more uniform fine-grain structure. However, this treatment was reported to reduce the fracture toughness. The maraging steels were less susceptible to failure than the two conventional high-strength steels in this test program.

The effect of changes in processing conditions on grain size and resistance to SCC is also shown in table 56 (ref. 154). Two experimental heat treatments intended to simulate improper processing are compared with the standard treatment. Solution annealing at 2200° F caused significant grain growth and resulted in poor resistance to SCC. Specimens cooled to and

held at 1400° F from the 2200° F solution annealing temperature were even more susceptible. This treatment would tend to cause harmful precipitation at the grain boundaries.

The reversion of martensite to austenite during heating of the maraging steels is discussed thoroughly in chapter 3. Reversion has been observed in maraging steels that have been heated at temperatures between the aging and annealing ranges, and the extent of reversion depends on the time and temperature of the treatment. The austenite that is formed during such heating is stable, and therefore does not change back to martensite when the metal is cooled to room temperature. The presence of the stable austenitic phase is reported to affect the formability, machinability, cold-working behavior, and stress-corrosion resistance (ref. 167). Figure 88 shows that the resistance to SCC is markedly influenced by the aging temperature (ref. 168). The temperatures used (800°, 900°, 1000°)

TABLE 55.—*Effect of Composition and Strength Level on Stress-Corrosion Cracking*^a
[From ref. 166]

Alloy type ^b	Ti content, percent	0.2 percent offset yield strength, ksi	Failure ratio and time, hr ^c				
			Distilled water		3 percent NaCl		
			Ratio	Time	Ratio	Time	
<i>Annealed and Aged</i> ^d							
18-7-5 -----	0.50	250	3/3	70	3/3	140	
18-9-5 -----	.52	255	0/3	NF 3600	0/2	NF 3600	
18-9-5 -----	.62	283	3/3	36	3/3	36	
18-9-5 -----	1.00	323	3/3	24	2/2	6.5	
18-8-3 -----	.23	182	0/3	NF 5080	0/3	NF 5712	
18-8-5 -----	.52	248	3/3	1032	0/3	NF 5040	
18-8-5 -----	.49	270	3/3	3190	3/3	1940	
18-9-5 -----	.55	279	3/3	510	3/3	119	
<i>50 Percent Cold Reduced and Aged</i> ^d							
18-9-5 -----	0.40	278	0/3	NF 3600	0/2	NF 3600	
18-7-5 -----	.50	303	3/3	1780	2/3	3200	
18-9-5 -----	.52	331	0/3	NF 3600	0/2	NF 3600	
18-9-5 -----	.62	324	4/4	536	3/3	1580	
18-9-5 -----	1.00	354	3/3	4460	2/2	20	
<i>Conventional High-Strength Steels</i>							
H-11 -----		219	1/2	1828	2/2	853	
H-11 -----		233	2/2	544	2/2	416	
D 6 Ac -----		203	0/3	NF 3984	0/2	NF 4700	
D 6 Ac -----		237	3/3	720	1/3	NF 4464	

^a Transverse bent-beam specimens, stressed to 75 percent of yield strength.

^b Numbers refer to Ni, Co, and Mo percentage, respectively.

^c Ratio of samples failed to samples tested; median failure time; NF = not failed.

^d Aged at 900° F, 3 hr.

and 975° F) were selected to form increasing amounts of stable austenite, although insuring that the ultimate strengths at the two temperature extremes were similar. The curves show that the life of stressed specimens increased markedly with increasing aging temperature. Aging at 975° F resulted in about a twentyfold increase in life, under equal stresses, compared to aging at 800° F. It should be emphasized, however, that this relationship cannot be extrapolated to cover still higher aging

temperatures because other changes occur that can influence the results. For example, higher temperature aging results in growth and precipitation of age-hardening compounds in the grain boundaries. This is harmful from a stress-corrosion standpoint. Also, the larger proportion of stable austenite formed at higher aging temperatures lowers the strength of the alloy.

The improved formability of maraging steels that have been intentionally heated to cause some reversion of martensite to aus-

TABLE 56.—Effect of Heat Treatment on Resistance of 18 Percent Ni 250-Grade Steel to Stress-Corrosion Cracking

[From ref. 154]

Heat treatment, F/time, hr	Grain size	Time to visible ^a cracking, days in 3.5 percent NaCl
CR, 1500/1/4, AC; 900/3, AC ^b	Small	OK, OK ^c
CR, 2200/1, WQ; 900/3, AC	Very large	3, 6
CR, 2200/1-1400/24, AC; 900/3, AC	Very large	0.2, 0.6
CR, 2200/1-1400-24, AC; 2200/1, WQ; 900/3, AC	Very large	0.2, 0.8

^a U-bend specimens.

^b CR=cold rolled; WQ=water quenched; AC=air cooled to room temperature.

^c Test terminated after 30 days.

tenite has made it possible to produce very-high-strength wire having a certain measure of ductility (refs. 167 and 168). A processing sequence involving a reversion treatment at 1150° F, followed by cold drawing and aging, was used to produce wire having a tensile strength of 430 ksi, with good ductility and improved stress-corrosion-cracking resistance (ref. 168). This wire had a life of 83 days at Kure Beach, N.C. (80-ft lot), compared to 5 days for a cold-worked and aged wire at the same strength level.

A comparative investigation of the effects of a number of variables on the mechanical properties and resistance to SCC of several high-strength steels included 18-9-5 and 18-7-5 maraging steels in the program (ref. 169). Among the variables evaluated were grain direction, product form, strength level (177- to 272-ksi yield strength), environment, welding, and effect of deformation after heat treatment. The resistance to SCC was tested by alternate immersion in a 3.5-percent sodium chloride solution, using a cycle of 8 minutes' immersion every hour until failure, or until 1000 hours had elapsed. Plate and billet material specimens,

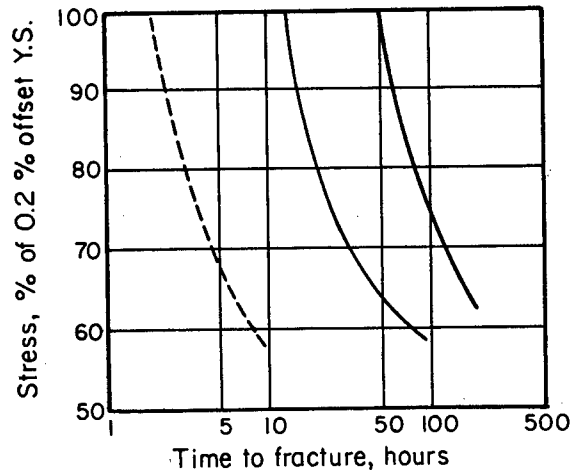

FIGURE 88.—Influence of heat treatment on stress-corrosion cracking resistance of 18 Ni-9 Co-5 Mo maraging steel (ref. 167).

----- 1560° F/2 hr/O.Q.+800° F/3 hr/A.C.
(VTS 263 ksi)
——— 1560° F/2 hr/O.Q.+900° F/3 hr/A.C.
(VTS 284 ksi)
——— 1560° F/2 hr/O.Q.+975° F/3 hr/A.C.
(VTS 263 ksi)

0.25 inch thick, were stressed to 80 percent of their yield strength in the Boeing U-bend configuration. This configuration is not a U-bend in the sense used earlier in this report, but is a modified bent beam adapted to thick plate and billet material. The design was reported to produce very uniform stresses in the desired area of the specimen. The 18-7-5 specimens from billet and plate material survived the 1000-hour test period in all of the laboratory tests without failure. One specimen exposed to the atmosphere in Seattle, Wash., cracked after 3456 hours of exposure, although a duplicate did not crack in 3730 hours. This was an excellent overall performance. The 18 Ni-7 Co-5 Mo plates and billets were among the least susceptible alloys at about the 250-270-ksi yield strength level in the comparative test program. This is shown in table 57. It was evident, however, that the susceptibility to SCC increased greatly as the yield strength approached 300 ksi. An 18 Ni-9 Co-5 Mo plate specimen having a yield strength of 300 ksi failed within 1 day in the test.

TABLE 57.—*Summary of the Least Susceptible Alloys at Various Strength Levels*^a
[From ref. 168]

Yield strength, ksi	Alloy	Alloy form
270 -----	18-7-5 -----	Billet
210 to 230 ----	18-7-5, martempered 4335 M, and D6AC	Billet
170 to 190 ----	H-11, 4335M, and 4340 --	Billet
255 -----	18-7-5 -----	Plate
210 to 220 ----	9Ni-4Co, 4335M -----	Plate
180 to 200 ----	17-4PH -----	Plate

^a Alternate immersion, 8 min wet, 52 min dry, in 3.5 percent NaCl. Stressed to 80 percent of the yield strength.

This point was also demonstrated in another evaluation of ultra-high-strength maraging steels (ref. 170). The data are summarized in tables 58 and 59. Yield strengths of about 330 ksi were obtained by raising the titanium content to about 1.25 percent. However, this was at the expense of notch toughness, and the alloys also were very susceptible to stress-corrosion cracking. The standard 300-grade material with a titanium content of about 0.7 percent had considerably higher notch strength and better resistance to stress-corrosion cracking.

Explosive forming is a new method of fabrication that is being investigated. In this process an explosive charge provides the energy to deform the metal into the desired shape. This is a severe cold-forming operation and it is important to know the effect of such treatments on the properties of the metal. Some information has been published on this recently (ref. 171), indicating that explosive deformation followed by aging reduced the mechanical properties only very slightly in the case of the 18-percent nickel maraging steels. The effect on resistance to stress corrosion was also evaluated by noting the change in mechanical properties after exposure. Four-point loaded, bent-beam specimens stressed to 80 percent of the yield strength were exposed to alternate immersion in 3.5 percent sodium

chloride solution for 200 hours. This caused a decrease in tensile strength from 258 ksi to 229 ksi on the undeformed specimen, whereas the decrease for the explosively deformed specimen was only from 253 ksi to 238 ksi. It was hypothesized that the changes in properties observed for deformed material may be caused by changes in response to heat treatment, rather than by the forming operation itself.

It was mentioned earlier that most of the stress-corrosion-cracking tests were conducted in saline environments. A few tests in other environments were reported in reference 161. The environments are listed below in an approximate decreasing order of aggressiveness in causing stress-corrosion failure of maraging steels:

- Natural sea-water immersion
- 140° F water-saturated air
- Aerated 3 percent NaCl solution
- Aerated distilled water
- Kure Beach, N.C., marine atmosphere
- Bayonne, N.J., industrial atmosphere
- Newport Beach, Calif., marine atmosphere
- Aerated tap water
- 0.25 percent Na₂Cr₂O₇ solution
- 4 percent soluble oil
- Trichlorethylene

Weldments

Considerable effort has been expended in the development of satisfactory welding procedures for the maraging steels. Consequently, several evaluations of the stress-corrosion properties of welds have been made. In the cases where data are available, the weld metal is somewhat inferior to the base-plate metal in resistance to SCC. However, welded plates have performed very well in several laboratory tests.

Plates of 18 Ni-7 Co-5 Mo were welded using manual and automatic fusion welding by the GTA (argon) process (ref. 169). The weld wire was of approximately the same composition as the plates. Specimens of the Boeing U-bend configuration were stressed to 205 ksi (80 percent of the yield strength) and tested by alternate immersion in a

TABLE 58.—*Tensile Properties of Ultra-High-Strength Maraging Steels Evaluated in Stress-Corrosion Tests*^a

[From ref. 170]

Melting practice	Titanium content, percent	0.2 percent offset yield strength, ksi	Ultimate strength, ksi	Notch strength, ^b ksi	Notch-to-yield strength ratio
Vacuum -----	1.32	328	335	130	0.39
	.66	284	289	259	.90
Air -----	1.25	336	340	147	.44
	.75	289	294	233	.79

^a See table 61.^b Root radius 0.001 in. or less; $K_t > 17$.TABLE 59.—*Stress-Corrosion Cracking Tests on Ultra-High-Strength Maraging Steels*^a

[From ref. 170]

Material	0.2 percent offset yield strength, ksi	Days to failure in—				
		Tap water ^c	3 percent NaCl ^c	40-1 soluble oil ^c	Atmosphere ^c	
VAR ^b	1.32 percent Ti	328	46	<1	19	20
	0.66 percent Ti	284	NF(600) ^d	NF(600)	NF(600)	337
Air ---	1.25 percent Ti	336	26	<1	5	35
	0.75 percent ---	289	NF(600)	NF(600)	2NF(600) 1(200)	185

^a Bent-beam tests; specimens stressed to 75 percent of yield strength.^b VAR=vacuum-arc remelt.^c Average of 3 tests.^d NF=no failure; number in parentheses=days' exposure.

3½-percent salt solution. No failures occurred in a 1000-hour test period. With the exception of a few specimens at much lower stress levels, all of the other alloy weldments tested failed in much shorter exposure periods. Excellent performance of welded material was also reported (ref. 172) in connection with the long-range investigation of materials for use in submarine hulls. In this test strips of plate were cut parallel to the rolling direction, and one longitudinal weld pass was made without filler metal by the GTA (gas tungsten-arc) process on one surface of the strip. U-bend specimens were prepared with the weld on the convex side. This procedure stressed the outer fibers beyond the 0.2-percent off-

set yield strength. Welded and unwelded test specimens of 18 Ni-8 Co-3 Mo 200 grade and 12 Ni-5 Cr-3 Mo steels were exposed to the following marine environments:

(1) Sea water; total immersion, 1 to 2 feet below the surface in quiescent water at Wrightsville Beach, N.C.

(2) Sea water; tide zone, specimens suspended so that they were below the high-tide line and above the low-tide line. Alternate wetting and drying occurred twice a day.

(3) Sea water, flowing at about 2 feet per second.

(4) Marine atmosphere in the 80-foot lot at Kure Beach, N.C.

None of the 18 Ni-8 Co-3 Mo welded or unwelded specimens had failed during an exposure period of 750 days. Another set of 18 Ni-8 Co-3 Mo specimens was given various combinations of annealing, welding, and aging (applied to the aged mill-treated material) as follows:

- (1) Annealed at 1500° F, 1 hour
- (2) Welded
- (3) Welded and aged 900° F, 3 hours
- (4) Annealed 1500° F, 1 hour, and welded
- (5) Annealed 1500° F, 1 hour, welded and aged 900° F, 3 hours.

These were exposed in the sea-water tide zone and in flowing sea water for 750 days and no failures resulted.

In several other investigations, welded maraging steels were evaluated by determining the K_{Isc} values, using precracked cantilever-beam test specimens. Figure 89 shows that the threshold value of K_{Isc} through the weld of a 215-ksi yield strength material in 3.5 percent salt solution is about 70 ksi $\sqrt{\text{in}}$. This compares with the value of 78 ksi $\sqrt{\text{in}}$ shown in figure 90 (ref. 173) for a weld material of 198-ksi yield strength. Table 60 summarizes the results reported (ref. 165) for a comparison of air and vacuum-induction-melted materials, and GTA deposited weld metals of the same composition. The comparison for the base materials was discussed earlier.

The comparison of the weld metals shows again that the material with the higher K_{Ic} fracture toughness does not necessarily have the best resistance to SCC. Although the 12 Ni GTA weld metal had a higher K_{Ic} value than the 18 Ni weld metal, the latter was considerably more resistant to SCC, having a K_{Isc} of 60 ksi $\sqrt{\text{in}}$ (compared with only 38 ksi $\sqrt{\text{in}}$.) for the 12Ni weld metal.

Results of Hydrogen-Stress Cracking Investigations

Quantitative data on the hydrogen embrittlement of the maraging steels are relatively meager, compared to that avail-

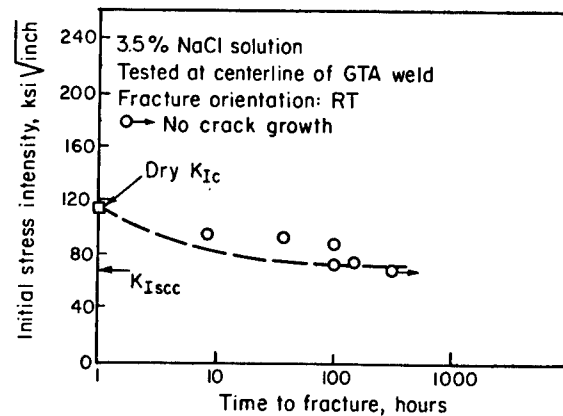

FIGURE 89.—Stress-corrosion curve for an 18-percent nickel, 215-ksi YS, maraging steel (ref. 162).

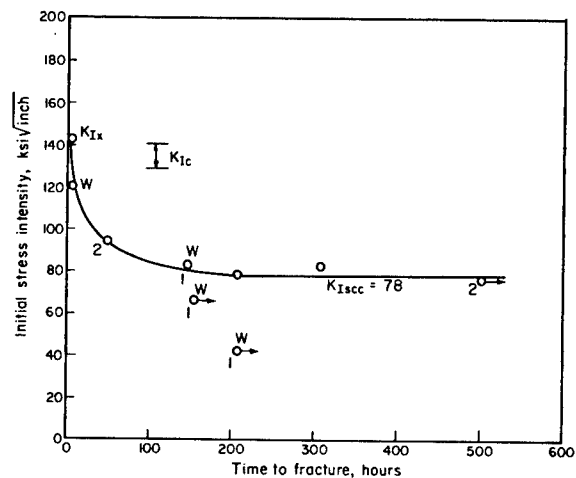

FIGURE 90.—Stress corrosion of weld centerline metal (ref. 173). Numbers adjacent to the points indicate that the specimens have been step loaded that many times (i.e., the load on an unbroken specimen in test was increased). Points marked "W" designate specimens taken from an area where the weld had been repaired.

able for stress-corrosion cracking. The subject is of interest, however, because previous experience with other steels has shown that for susceptible materials the chances for failure become greater with increasing strength of the metal. It was indicated earlier that the source of the hydrogen is of little importance. It may be introduced during melting or heat-treating operations; during cleaning, pickling, or electroplating processes; or it may be picked up from service environments as a result of cathodic

TABLE 60.—*Summary of Properties for 12 Ni and 18 Ni Maraging Steels and Weldments Investigated*^a

[From ref. 165]

Steel and melting practice	Yield strength 0.2 percent offset, ksi	Charpy V-notch impact energy, ft-lb	K_{Ic} , ^b ksi $\sqrt{\text{in.}}$	K_{Isc} , ^b ksi $\sqrt{\text{in.}}$
12 Ni airmelted.	176	36	130	40
12 Ni vacuum-induction- melted.	183	60	169	108
12 Ni GTA weld metal.	164	45	148	38
18 Ni air-melted.	178	35	118	108
18 Ni vacuum-induction- melted.	175	54	142	120
18 Ni GTA weld metal.	191	24	94	60

^a 1000-hr tests in synthetic sea water.^b Calculated using Bueckner's equation and Irwin's correction for face notching ($m=1/2$).

protection or corrosion reactions. Thus, there are numerous opportunities for a susceptible material to pick up enough hydrogen to cause serious embrittlement and result in failure under stress.

The design of laboratory experiments to provide quantitative results on the behavior of materials under HSC conditions becomes quite difficult because of the number of factors that must be considered. A common way to make hydrogen available for entry into the metal is by cathodic charging. Nascent hydrogen is formed by electrolysis in an electrolytic cell in which the test specimen serves as the cathode. This procedure was used in some early studies on the effect of hydrogen in maraging steels (ref. 174). Specimens were charged for various lengths of time and then immediately cadmium-plated to retain the absorbed hydrogen. Embrittlement was evaluated by measuring the reduction of area in a tensile test. It was found that an 18 percent nickel 300-grade steel required considerably longer charging periods than AISI 4340 steel to cause an equivalent loss in ductility. Cathodic charging with hydrogen for about 2 hours was also observed to cause a decrease in the notched tensile strength of 18 Ni 250-grade maraging steel (ref. 175). The reduced ductility observed

in these tests shows that hydrogen has an embrittling effect, but other tests were necessary to correlate this with delayed fracture. Such tests have often been made in the presence of aqueous environments (refs. 175, 176, 177, and 178). This raises the question of whether the mechanism of failure was stress-corrosion cracking or hydrogen-stress cracking. Earlier in this chapter (see table 57), the results of bent-beam tests of maraging steels in distilled water were presented. These were part of a comprehensive investigation of stress-corrosion cracking. The results indicated that failures in distilled water, in general, were more prevalent as the strength level was increased by compositional changes. Some contradictory results were thought to be due to unknown differences in prior processing history.

It was noted that 18 Ni maraging steel (230-ksi yield strength) did not fail in 100 hours of exposure to distilled water as a fatigue-cracked, center-notch specimen stressed in direct tension (ref. 176). Low-alloy steels were much more susceptible to hydrogen-stress cracking, and based on a study of the latter, the authors concluded that failures were caused by hydrogen, but that the hydrogen was formed by corrosion reactions. A much higher strength maraging

steel, heat treated to get yield strengths in the 270–322-ksi range, failed within 20 to 30 hours in a similar test when stressed between 80 and 140 ksi (ref. 178). No failures occurred in 1000 hours at applied stresses of less than 40 ksi. In general, therefore, the lower strength maraging steels were fairly resistant to cracking even in a distilled-water environment. The susceptibility to failure increased when alloys were in the 300-ksi yield strength range.

A comprehensive investigation of the hydrogen embrittlement of a number of high-strength steels, including 18 percent nickel maraging steel, is being conducted for NASA George C. Marshall Space Flight Center. The results of the first 2 years of work have been summarized in annual reports to the sponsor (refs. 179, and 180). The initial experiments were designed to determine the life of smooth, round specimens under stress, while being continuously charged with hydrogen. Four charging conditions ranging from severe to very mild were used. The alloys in test were rated according to the severity of charging that they could withstand without failure for 200 hours, although stressed at 80 percent of their yield strength. It was found that 18 percent nickel maraging steel (0.2 percent yield strength, 258 ksi) was in the group that failed only under the two most severe charging conditions. Compared to other materials at the same strength level, the maraging steel was definitely more resistant to HSC. Comparison of the rates at which hydrogen entered the alloys, and also of the average hydrogen content of the alloys charged under conditions that did or did not produce failure, seemed to indicate that the presence of a critical amount of hydrogen may be more important than the entry rate. Alloys AISI 4340, AISI H-11, and the 18 percent nickel maraging steel all heat treated to the 260-ksi strength level showed marked differences in their average hydrogen content and entry rates, as well as in their susceptibility to cracking.

Tests to evaluate the embrittling tendencies of cleaning, pickling, and plating

processes and the results obtained are reported in reference 180. Notched-bar specimens were given several standard cleaning and pickling treatments and then loaded to 90 percent of the notched tensile strength (NTS was 407 ksi) for periods exceeding 100 hours without failure. Analysis for hydrogen after the treatments indicated that, in most cases, the treated specimens had lower hydrogen content than specimens that had not been exposed to the cleaning treatments.

Similar notched specimens were nickel plated or hard-chromium plated and then subjected to a sustained load of 90 percent of the notched tensile strength. The nickel-plated specimens survived the 100-hour test period, but the hard chromium failed on loading to about 79 percent of the NTS. However, they did survive the 100-hour period when stressed only to 75 percent of the NTS. In these plating evaluations, the maraging steel performed appreciably better than the AISI 4340 or H-11 steels. With the exception of the hard-chromium plating operation, it appears that the other cleaning, pickling, or plating operations did not introduce enough hydrogen to harm the maraging steel.

The results of the investigations on the stress-corrosion cracking of the 18 percent nickel maraging steels may be summarized very briefly. The steels are susceptible to cracking in corrosive environments, but their performance is, in most cases, superior to that of other high-strength steels of similar strength levels. It is important to note, however, that for best results, good processing practices must be used to obtain clean, fine-grained material. There is also a limit to the strength level at which the present maraging steels may be used in corrosive environments under stress. When the yield strength is greater than about 280 ksi, the resistance to stress-corrosion cracking decreases rapidly. Therefore, measures must be taken to either reduce the applied stresses or to insulate the steel from the corrosive environment.

On the basis of limited data, essentially the same conclusions may be made regarding the susceptibility of the maraging steels to hydrogen-stress cracking. Steels at the 250-ksi or lower strength level have better resistance than the low-alloy steels of similar strength. The higher strength maraging steels, such as the 300 or 350 grade, are much more susceptible to hydrogen-induced delayed failure.

Ordinary pickling and plating operations (except for chromium plating) did not appear to introduce enough hydrogen into the metal to be troublesome. In situations where harmful quantities of hydrogen are absorbed, such as from chromium plating, it may be necessary to resort to baking at elevated temperature to drive the hydrogen out. Twenty-four hours at 375° F or 2 hours at 600° F have been suggested (ref. 180).

CHAPTER 8

Future Prospects

The maraging steels have made a tremendous impact on many segments of the aerospace, defense, and industrial communities of the United States, and they have also aroused a great deal of interest abroad. The reasons are clear. As this report attests, the various grades of maraging steel that have reached the status of commercial availability have demonstrated extraordinary levels of, and combinations of, desirable properties and have thrust themselves into an impressive number and variety of applications.

Has the extraordinarily rapid development of these steels left little prospect for more than minor gains and refinements in the future? Or, is there more to come?

The indications are strong that there is more to come. The extraordinary qualities of carbon-free, or essentially carbon-free, martensite as a host for precipitation-hardening reactions and as a matrix for solid-solution strengthening are just beginning to be appreciated. The strength and hardness potential of this type of martensite when liberally alloyed with such elements as nickel, cobalt, and molybdenum has only recently come under study (ref. 181). Alloys already have been found that can be age hardened to yield strengths of 400 to 500 ksi. At the 500-ksi level, the corresponding elongation has been sufficient to be measurable, 0.5 to 1.0 percent; while at the 400-ksi level, the elongation has been a remarkable 6 to 8 percent.

Some maraging steels have reached the extreme hardness of R_c 71 on aging (ref. 181). Assuming that these alloys follow

the theoretical strength-hardness relationship for steel, their tensile strength at this hardness level should be about 800 ksi. Of course, the factor that limits realization of such high strength is fracture toughness. In the past, achievement of tensile strengths in the range of 500 to 600 ksi has depended on extremes of strain hardening, either by itself or in conjunction with heat treatment, and has been confined to fine wire, thin strip, small shapes, and test pieces. In the maraging type of alloy, such strength can be obtained by thermal treatment alone. This opens the possibility that a meaningful amount of fracture toughness can be achieved and that it can be accomplished in material having appreciable cross-sectional area, thereby making available useful structural materials possessing unbelievable strength.

Nor is the development of extraordinary strength combined with useful fracture toughness the only achievement on the horizon of the maraging steels. Stainless maraging steels are in the offing (ref. 182). The near-term prospects are for a stainless alloy with a yield strength of 180 ksi and a room-temperature Charpy V-notch value of 60 ft-lb. Later on, yield strengths up to 280 ksi may be expected.

New alloys, with development well underway, are maraging steels of lower alloy content than the 18 percent nickel alloys that possess yield strengths in the vicinity of 150 to 180 ksi. The superior resistance of these steels to stress-corrosion cracking and hydrogen-stress cracking, coupled with their

exceptional fracture toughness, may make them prime candidates for submarine hulls, deep submergence vehicles, and high-performance deep-sea stationary structures. The cobalt-free varieties should find considerable application in the nuclear-power fields.

Because of refinements in composition and processing procedures the higher strength grades of 18 percent nickel maraging steel may be made into wire having exceptional properties, especially suited to heavy-duty cable applications (ref. 182). Also, the future holds promise for the development of

magnetic grades of maraging steels that combine high strength and toughness with desirable coercive force and saturation magnetization. Finally, research is in progress that can be expected to result in the development of improved toughness in massive sections of maraging steel, even when they are aged to yield strength levels as high as 280 ksi (ref. 182).

When these burgeoning developments and attractive possibilities are superimposed on the healthy position the maraging steels has already reached, it is clear that their future is promising.

References

1. Preliminary Data Sheets for 18%, 20%, and 25% Nickel Maraging Steels. The International Nickel Co., Inc., New York, N.Y.
2. BIEBER, C. G.: Progress With 25% Nickel Steels for High-Strength Applications. *Metal Progress*, vol. 78, Nov. 1960. pp. 99-100.
3. Interim Data Sheet. The International Nickel Co., Inc., New York, N.Y., Nov. 17, 1962.
4. Preliminary Data Sheet on 12-5-3 Maraging Steel. The International Nickel Co., Inc., New York, N.Y., June 1966.
5. SADOWSKI, E. P.; AND DECKER, R. F.: Cast Maraging Steel. *Modern Castings*, vol. 43, Feb. 1963, pp. 81-88.
6. FLOREEN, S.; AND DECKER, R. F.: Maraging Steel for 1000 F Service. *Trans. Am. Soc. Metals*, vol. 56, 1963, pp. 403-411.
7. Experimental Data Sheet for 18% Nickel 350 Maraging Steel. The International Nickel Co., Inc., New York, N.Y.
8. PATTERSON, W. R.; AND RICHARDSON, L. S.: The Partial Substitution of Manganese for Nickel in Maraging Steel. *Trans. Am. Soc. Metals*, vol. 59, 1966, pp. 71-84.
9. AEROJET-GENERAL CORP.: Evaluation of High Nickel Steel for Application in Large Booster Motor Fabrication. ML-TDR-64-115, Apr. 1964.
10. AEROJET-GENERAL CORP.: 260-in.-Diameter Motor Feasibility Demonstration Program. Final Program Summary Report. NASA CR-72127, Apr. 8, 1966. Contract no. NAS 3-6284.
11. GARLAND, C.: Fabrication of 260-in.-Diameter Rocket Cases With Maraging Steel. *Welding Journal*, vol. 45, 1966, pp. 22-29.
12. CRIMMINS, P. P.; AND TENNER, W. S.: How To Weld Thick Plates of 18% Nickel Maraging Steel. *Metal Progress*, vol. 87, no. 5, May 1965, pp. 57-62.
13. ABBOTT, W. D.: Study and Evaluation of Fabrication Methods Necessary for Production of Large Diameter Solid Propellant Rocket Motor Cases. Excelco Developments, Inc., Silver Creek, N.Y., Final report on Contract NASw-687, Dec. 1965.
14. ROMINE, H. E.: Plane Strain Fracture Toughness of 18 Ni (250) and 18 Ni (200) Maraging Welded Steel Plate. U.S. Naval Weapons Laboratory, Dahlgren, Va., NWL Report no. 1959, Jan. 8, 1965.
15. ROMINE, H. E.: Information on Fracture Toughness Specimens From Welded Plates of 250 and 200 Grades of 18 Ni Maraging Steel. U.S. Naval Weapons Laboratory, Dahlgren, Va., NWL Report no. 1997, Oct. 20, 1965.
16. ABBOTT, W. D.: Report on the Non-destructive Testing Techniques Used on Large Cases Fabricated from 18% Nickel Maraging Steel. Quarterly Report on Contract NASw-687, Dec. 1964, Excelco Developments, Inc., Silver Creek, N.Y.
17. SRAWLEY, J. E.; AND ESGAR, J. B.: Investigation of the Hydrotest Failure of Thiokol Chemical Corporation 260-in.-Diameter SL-1 Motor Case. NASA TM X-1194, Jan. 1966.
18. COVERDALE, J. S.; WELLS, N.; SKOPP, G.; AND BROKER, G.: 156-in.-Diameter Maraging Steel Hydroburst and Materials Evaluation. AFRPL-TR-66-350, Lockheed Propulsion Co., Redlands, Calif., Jan. 1967.
19. TIFFANY, C. F.; MASTERS, J. N.; AND REGAN, R. E.: Large Motor Case Technology Evaluation. AFML-TR-67-190, The Boeing Co., Aug. 1967.
20. HAMAKER, J. C., JR.; AND YATES, D. H.: New High-Strength Steel Applications. Paper presented at The Western Metal Congress (Los Angeles, Calif.), Mar. 1966.
21. GERMER, J.: Fabrication and Fracture Toughness of 0.020-in.-Thick Maraging Steel Experimental Cases. Final report contract DA-01-021-AMC-12524 (Z), The Budd Co., Philadelphia, Pa., May 22, 1967.
22. COLEMAN, A. A.: High-Strength Maraging Steels for Tactical Missile Rocket Motors. Report R-4384, Rocketdyne, division of North American Aviation, Inc., McGregor, Tex., July 13, 1966.
23. ASTM Designation A-538-65: 18% Nickel Precipitation Hardening (Maraging) Alloy

- Steel Plates for Pressure Vessels. ASTM Standards, Pt. 4, Jan. 1967, pp. 818-819.
24. BERNSTEIN, HAROLD: Structures and Materials for Deep Submersibles. *Astronautics and Aeronautics*, vol. 5, no. 7, July 1967, pp. 68-74.
 25. FITZPATRICK, J. M.: Next-Generation Submersible Pressure Hull Metals. Report 5-10-67-3, Lockheed Palo Alto Research Laboratory, Dec. 1966.
 26. SCHAPIRO, L.: High-Strength Steels in Deep Submersibles. Paper presented at the National Metal Congress (Cleveland, Ohio), 1967.
 27. UNDERWATER STORAGE, INC.: Specifications for a Prototype Buoyant Vessel for Undersea Exploration. Prepared under contract to the Bureau of Yards and Docks (contract NBY 63878), Jan. 15, 1966.
 28. YATES, D. H.; AND HAMAKER, J. C., JR.: Maraging Steels in Tooling Applications. *Metal Progress*, vol. 90, no. 2, Aug. 1966, pp. 75-78.
 29. HAMAKER, J. C., JR.; AND YATES, D. H.: Maraging Steel . . . A New Die Material. *Die Casting Engineer*, Apr.-May 1966.
 30. Almar 18 Steels for Tooling Applications. Allegheny-Ludlum Steel Corp., Pittsburgh, Pa., 1965.
 31. Maraging Steel Selected as "Standard" by Metalonics Corporation. *Inco Nickel Topics*, vol. 18, no. 2, 1965, p. 10.
 32. Maraging Steel . . . The Answer to a Problem in Extrusion. *Inco Nickel Topics*, vol. 20, no. 4, 1967, p. 9.
 33. Nickel Maraging Steel Solves a Critical Materials Problem for Hartford Special Machinery Company. *Inco Nickel Topics*, vol. 18, no. 1, 1965, p. 4.
 34. Flexures Measure Thrust of Giant Rocket Motors. *Inco Nickel Topics*, vol. 16, no. 7, 1963, p. 1.
 35. Nickel Maraging Steel Flexes Muscle To Help Rocket Wag Its Tail. *Inco Nickel Topics*, vol. 17, no. 7, 1964, p. 1.
 36. Maraging Steel Joints in Shaft Absorb Misalignment, Flexing Loads. *Metal Progress*, vol. 92, no. 6, Dec. 1967, p. 95.
 37. Maraging Steel Forgings Will Anchor Saturn 1-B Mobile Tower. *Inco Nickel Topics*, vol. 18, no. 7, 1965, p. 1.
 38. Vascomax 350 CVM. Ready Reference Data Sheet. Vanadium-Alloys Steel Co., Latrobe, Pa., 1966.
 39. SMITH, R.; WYCHE, E. H.; AND GORE, W. W.: A Precipitation-Hardening Stainless Steel of the 18% Chromium, 8% Nickel Type. T.P. No. 2006, *Metals Technology*, vol. 13, June 1946.
 40. Armco Precipitation-Hardening Stainless Steels. Technical Data Manual, Armco Steel Corp., Middletown, Ohio, 1966.
 41. KASAK, A.; CHANDHOK, V. K.; AND DULIS, E. J.: Development of New and Useful Elevated-Temperature Steels for Aircraft Applications. Report no. ASD-TR-61-386, Crucible Steel Co. of America, Pittsburgh, Pa., June 1962.
 42. KASAK, A.; CHANDHOK, V. K.; MOLL, J. H.; AND DULIS, E. J.: Development of High-Strength Elevated-Temperature, Corrosion-Resistant Steel. Report no. ASD-TDR-63-766, Crucible Steel Co. of America, Pittsburgh, Pa., Sept. 1963.
 43. Product Data—Armco PH13-8Mo Stainless Steel—Bar, Wire, Plate, and Forging Billet. Bulletin S-33a, Armco Steel Corp., Middletown, Ohio, July 1967.
 44. CLARKE, W. C., JR.; AND GARVIN, H. W.: Effect of Composition and Section Size on Mechanical Properties of Some Precipitation-Hardening Stainless Steels. ASTM STP no. 369, *Advances in the Technology of Stainless Steels and Related Alloys*, pp. 151-158, ASTM, Philadelphia, Pa., 1965.
 45. Product Data—Armco 15-5PH Precipitation-Hardening Stainless Steel Bar and Wire. Bulletin S-21, Armco Steel Corp., Middletown, Ohio, July 1966.
 46. Preliminary Technical Data Sheet on Carpenter Custom 455. Carpenter Steel Co., Reading, Pa., not dated.
 47. AGGEN, G. N.; HAMMOND, C. M.; AND LULA, R. A.: New Martensitic Age Hardening Stainless Steels. ASTM STP no. 369, *Advances in the Technology of Stainless Steels and Related Alloys*, pp. 40-46, ASTM, Philadelphia, Pa., 1965.
 48. HOMERBERG, V. O.: Nitriding. *Metals Handbook*, ASM, Cleveland, Ohio, Taylor Lyman, ed., 1948, pp. 697-702.
 49. Armco 17-7PH and PH15-7Mo Stainless Steel Sheet and Strip. Armco Steel Corp., Middletown, Ohio, 1966.
 50. Armco PH14-8Mo Precipitation-Hardening Stainless Steel Sheet and Strip. Armco Steel Corp., Middletown, Ohio, 1966.
 51. PERRY, D. C.; TANCZYN, H.; AND CLARKE, W. C., JR.: New PH Steel Matches Strength and Toughness. *Metal Progress*, vol. 83, June 1963, p. 101.
 52. LENA, A. J.: New Stainless Steel Bridges Gap Between 300 and 400 Series. *Iron Age*, vol. 174, Dec. 2, 1954, pp. 113-116.
 53. Preliminary Data Sheet—Precipitation Hardening Alloy—Allegheny Metal 350. Allegheny-Ludlum Steel Corp., Pittsburgh, Pa., May 9, 1955.

54. OWEN, E. A.; AND LIU, Y. H.: Further X-Ray Study of the Equilibrium Diagram of the Iron-Nickel System. *J. Iron and Steel Institute*, vol. 163, Oct. 1949, pp. 132-137.
55. JONES, F. W.; AND PUMPHREY, W. I.: Free Energy and Metastable States in the Iron-Nickel and Iron-Manganese Systems. *J. Iron and Steel Institute*, vol. 163, Oct. 1949, pp. 121-131.
56. HANSEN, M.: *Der Aufbau der Zweistofflegierungen*. Julius Springer (Berlin), 1936.
57. GILBERT, A.; AND OWEN, W. S.: Diffusionless Transformation in Iron-Nickel, Iron-Chromium and Iron-Silicon Alloys. *Acta Metallurgica*, vol. 10, 1962, pp. 45-54.
58. COHEN, M.: The Strengthening of Steel. *Trans. AIME*, vol. 224, 1962, pp. 638-657.
59. MILLER, G. P.; AND MITCHELL, W. I.: Structure of Nickel-Cobalt-Molybdenum Maraging Steels in the Air-Cooled Condition. *J. Iron and Steel Institute*, vol. 203, Sept. 1965, pp. 895-898.
60. KURDUMOFF, G.; AND KAMINSKY, E.: X-Ray Studies of the Structure of Quenched Carbon Steel. *Nature*, vol. 122, 1928, p. 475.
61. WINCHELL, P. G.; AND COHEN, M.: Solid Solution Strengthening of Martensite by Carbon. *Electron Microscopy and Strength of Crystals*, edited by G. Thomas and J. Washburn, Interscience Publishers, Inc., New York, 1962.
62. WINCHELL, P. G.; AND COHEN, M.: The Strength of Martensite. *Trans. Am. Soc. Metals*, vol. 55, 1962, pp. 347-361.
63. DECKER, R. F.; EASH, J. T.; AND GOLDMAN, A. J.: Eighteen Percent Nickel Maraging Steel. *Trans. Am. Soc. Metals*, vol. 55, Mar. 1962, pp. 58-76.
64. FLOREEN, S.: Hardening Behavior of Ternary Alloys Based on Iron-18% Nickel. *Trans. Am. Soc. Metals*, vol. 57, 1964, pp. 38-47.
65. REISDORF, BART G.: Identification of Precipitates in 18%, 20%, and 25% Nickel Maraging Steels. *Trans. Am. Soc. Metals*, vol. 56, 1963, pp. 783-787.
66. BAKER, A. J.; AND SWANN, P. R.: The Hardening Mechanism in Maraging Steels. *Trans. Am. Soc. Metals*, vol. 57, 1964, pp. 1008-1011.
67. MILLER, G. P.; AND MITCHELL, W. I.: Structure and Hardening Mechanisms of 18% Nickel-Cobalt-Molybdenum Maraging Steels. *J. Iron and Steel Institute*, vol. 203, Sept. 1965, pp. 899-904.
68. BANERJEE, B. R.; CAPENOS, J. M.; AND HAUSER, J. J.: Aging Kinetics in 300-Grade Maraging Steel. *Advances in Electron Metallography*, vol. 6, ASTM STP 396, Am. Soc. Testing Mats., 1966, pp. 115-131.
69. CHILTON, J. M.; AND BARTON, C. J.: Identification of Strengthening Precipitates in 18 Ni (250) Aluminum, Vanadium, and Titanium Maraging Steels. *Trans. Am. Soc. Metals*, vol. 60, 1967, pp. 528-542.
70. PETERS, D. T.; AND CUPP, C. R.: The Kinetics of Aging Reactions in 18% Ni Maraging Steel. *Trans. Met. Soc. AIME*, vol. 236, Oct. 1966, pp. 1420-1429.
71. MARCUS, HARRIS; SCHWARTS, LYLE H.; AND FINE, MORRIS E.: A Study of Precipitation in Stainless and Maraging Steels Using the Mössbauer Effect. *Trans. Am. Soc. Metals*, vol. 59, Sept. 1966, pp. 468-478.
72. MIHALISIN, J. R.: Age Hardening and Structure of Iron-Nickel-Cobalt Alloys. *Trans. Am. Soc. Metals*, vol. 59, 1966, pp. 60-70.
73. FLOREEN, S.; AND SPEICH, G. R.: Some Observations on the Strength and Toughness of Maraging Steels. *Trans. Am. Soc. Metals*, vol. 57, 1964, pp. 714-726.
74. FLOREEN, S.; AND DECKER, R. F.: Heat Treatment of 18% Nickel Maraging Steel. *Trans. Am. Soc. Metals*, vol. 55, 1962, pp. 518-530.
75. DECKER, R. F.: Maraging Steels; Structure-Property Relations. *Proceedings of Symposium, Relations Between the Structure and Mechanical Properties of Metals*. National Physical Laboratory, Teddington, England, Jan. 1963.
76. SADOWSKI, E. P.; AND DECKER, R. F.: Cast Maraging Steel. *Modern Castings*, vol. 43, Feb. 1963, pp. 81-88.
77. BROKLEFF, J. E.; AND KORTOVICH, C. S.: An Evaluation of Mechanical Properties of Cast Maraging Steels. *Trans. Am. Foundrymen's Soc.*, vol. 74, 1966, pp. 617-626.
78. CAMPBELL, J. E.; BARONE, F. J.; AND MOON, D. P.: The Mechanical Properties of the 18% Nickel Maraging Steels. *DMIC Report 198*, Feb. 24, 1964, Defense Metals Information Center, Battelle Memorial Institute, Columbus, Ohio.
79. DETERT, KLAUS: The Influence of Small Cold Deformation Preceding Aging in 15% and 18% Nickel Maraging Steel. *Trans. Met. Soc. AIME*, vol. 239, Apr. 1967, pp. 553-556.
80. CRIMMINS, P. P.: Evaluation of High Nickel Maraging Steel for Application in Large Booster Motor Fabrication. *Third Maraging Steel Project Review, Technical Documentary Report no. RTD-TDR-63-4048*, Air Force Materials Laboratory, Research Technology Division, Air Force Systems Command, Wright-Patterson Air Force Base, Ohio, Nov. 1963, pp. 95-183.
81. PELLISSIER, G. E.: Some Microstructural Aspects of Maraging (250) Steel in Relation to Strength and Toughness. *Third Maraging Steel Project Review, Technical Document*

- tary Report no. RTD-TDR-63-4048, Air Force Materials Laboratory, Research Technology Division, Air Force Systems Command, Wright-Patterson Air Force Base, Ohio, Nov. 1963, pp. 407-437.
82. BONISZEWSKI, T.; AND BONISZEWSKI, ELSPETH: Inclusions in 18 Ni-Co-Mo Maraging Steel. *J. Iron and Steel Institute*, vol. 204, pt. 4, Apr. 1966, pp. 360-365.
 83. HALL, A. M.: The Producibility of 18% Nickel Maraging Steel. DMIC Report S-8, July 30, 1963, Defense Metals Information Center, Battelle Memorial Institute, Columbus, Ohio.
 84. SHIMMIN, J. T.; GLASGAL, BARRY; AND ODAR, J. A.: Manufacturing Process Development for High-Strength Steels. Technical Report AFML-TR-66-340, Republic Steel Corp., Metallurgical Department, Central Alloy District, Canton, Ohio, Dec. 1966.
 85. COLEMAN, A. A.: High-Strength Maraging Steels for Tactical Missile Rocket Motors. Report R-4384, Rocketdyne, division of North American Aviation, Inc., Solid Rocket Division, McGregor, Tex., July 13, 1966.
 86. PELLISSIER, G. E.: Some Microstructural Aspects of Maraging (250) Steel in Relation to Strength and Toughness. Third Maraging Steel Project Review, Technical Documentary Report no. RTD-TDR-63-4048, Air Force Materials Laboratory, Research and Technology Division, Air Force Systems Command, Wright-Patterson Air Force Base, Ohio, Nov. 1963, pp. 407-437.
 87. Data Bulletin: 18% Nickel Maraging Steels. The International Nickel Co., Inc., New York, N.Y., Nov. 1964, 56 pp.
 88. Vascomax 200-250-300-350 18% Nickel Ultra-High-Strength Maraging Steels. Vanadium-Alloys Steel Co., Latrobe, Pa., 1966, 46 pp.
 89. THEVENOW, V. H.; VONNEGUT, G. L.; AND SIPPEL, G. R.: Effects of Mechanical and Thermal Processing on Structure and Properties of 18 Ni-Co-Mo Maraging Steel. Fourth Maraging Steel Project Review, Technical Documentary Report no. ML-TDR-64-225, vol. 1, Air Force Materials Laboratory, Research and Technology Division, Air Force Systems Command, Wright-Patterson Air Force Base, Ohio, July 1964, pp. 1-40.
 90. NOVAK, C. J.: Isothermal Embrittlement of 18% Nickel Maraging Steel. DMIC Memorandum 196, Report on Fourth Maraging Steel Project Review, Defense Metals Information Center, Battelle Memorial Institute, Columbus, Ohio, Aug. 19, 1964.
 91. PELLISSIER, G. E.: The Physical Metallurgy and Properties of Maraging Steels. DMIC Report 210, Problems in the Load Carrying Application of High-Strength Steels, Defense Metals Information Center, Battelle Memorial Institute, Columbus, Ohio, Oct. 26-28, 1964, pp. 173-188.
 92. BARTON, C. J.; REISDORF, B. G.; SALMON COX, P. H.; CHILTON, J. M.; AND OSKIN, C. E., JR.: Investigation of Thermal Embrittlement in 18 Ni (250) Maraging Steel. Technical Report AFML-TR-67-34, U.S. Steel Corp., Monroeville, Pa., Mar. 1967.
 93. SPAEDER, G. J.; BROWN, R. M.; AND MURPHY, W. J.: The Effect of Hot Rolling Variables on the Fracture Toughness of 18 Ni Maraging Steel. *Trans. Am. Soc. Metals*, vol. 60, 1967, pp. 418-425.
 94. DECKER, R. F.; NOVAK, C. J.; AND LANDIG, T. W.: Developments and Projected Trends in Maraging Steels. *Journal of Metals*, vol. 19, no. 11, Nov. 1967, pp. 60-65.
 95. Technical Service Letter: Planing, Sawing, and Drilling 18% Nickel Maraging Steel. The International Nickel Co., Inc., New York, N.Y., Oct. 1961, 16 pp.
 96. Summary Data Bulletin: 18% Nickel Maraging Steels. The International Nickel Co., Inc., New York, N.Y., Mar. 30, 1965.
 97. SHIMMIN, J. T.; GLASGAL, BARRY; AND ODAR, J. A.: Manufacturing Process Development for High-Strength Steels. Technical Report AFML-TR-66-340, Republic Steel Corp., Metallurgical Department, Central Alloy District, Canton, Ohio, Air Force Contract AF 33(657)-11277, Dec. 1966.
 98. Vascomax 200-250-300-350 18% Nickel Ultra-High-Strength Maraging Steels. Vanadium-Alloys Steel Co., Latrobe, Pa., 1966, 46 pp.
 99. HALL, A. M.: High-Strength Constructional Alloy Steels. Chapter in *Modern Materials*, vol. 4, Academic Press, Inc., New York, N.Y., 1964, pp. 327-406.
 100. Data Bulletin: 18% Nickel Maraging Steels. The International Nickel Co., Inc., New York, N.Y., Nov. 1964, 56 pp.
 101. SPARKS, ROBERT B.: Working With Maraging Steels—Forging. *Metal Progress*, vol. 84, no. 1, July 1963, pp. 74-77.
 102. COLEMAN, A. A.: High-Strength Maraging Steels for Tactical Missile Rocket Motors. Report R-4384, Rocketdyne, division of North American Aviation, Inc., Solid Rocket Division, McGregor, Tex., July 13, 1966.
 103. RAYMER, J. M.: Metastable Austenitic Forming of High-Strength Pressure Vessels. Technical Documentary Report no. ML-TDR-64-174, Lycoming Division, Avco Corp., Stratford, Conn., July 1964.
 104. SCOW, A. L.: Development of Extruding, Drawing, and Heat Treating Processes for Thin Steel Extrusions. Interim Engineering Progress Report no. 2, Dec. 1965, and Interim Engineering Progress Report no. 5, Oct. 1966. Northrop Norair, division of

- Northrop Corp., Hawthorne, Calif., Air Force Contract AF 33(615)-3159.
105. CAMPION, D. J.: Spinning and Related Forming Techniques With Particular Reference to Maraging Steel. *Sheet Metal Industries*, vol. 44, Mar. 1967, pp. 160-166.
 106. FOWLER, E. L.: Cold-Forming of Maraging Steels. *Machinery (U.S.)*, vol. 71, no. 8, Apr. 1965, pp. 118-124.
 107. GERDS, A. F.; GLAESER, W. A.; HENNING, H. J.; HOPPER, A. T.; MUKHERJEE, A. K.; PUGH, H. L. D.; AND STROHECKER, D. E.: Metal Deformation Processing, Vol. II. DMIC Report 226, Defense Metals Information Center, Battelle Memorial Institute, Columbus, Ohio, July 7, 1966.
 108. SRAWLEY, JOHN E.; AND ESGAR, JACK B.: Investigation of Hydrotest Failure of Thiokol Chemical Corporation 260-in.-Diameter SL-1 Motor Case. NASA Technical Memorandum NASA TM X-1194, National Aeronautics and Space Administration, Washington, D.C., Jan. 1966.
 109. DETHLOFF, R. C.: High Performance Rocket Motor Cases. Maraging Steel Project Review, ASD Technical Documentary Report 63-262, Air Force Materials Laboratory, Aeronautical Systems Division, Air Force Systems Command, Wright-Patterson Air Force Base, Ohio, May 1963.
 110. KULA, ERIC B.; AND HICKEY, CHARLES F., JR.: Thermomechanical Treatments of the 18% Ni Maraging Steels. *Trans. The Metallurgical Society of AIME*, vol. 230, Dec. 1964, pp. 1707-1712.
 111. WILSON, GEORGE F.: Machining Evaluation of High-Strength Maraging Steel. EM 66-162, presented at the Engineering Conferences, ASTME, 1966, 8 pp.
 112. *Materials for Cutting Tools*. Metals Handbook, 8th ed., vol. 3, Machining, Taylor Lyman, ed., American Society for Metals, Metals Park, Ohio, 1967, pp. 311-332.
 113. ZLATIN, NORMAN; CHRISTOPHER, JOHN; AND JAMESON, ROBERT T.: Machining Characteristics of 18% Nickel Maraging Steels. EM 66-163, presented at the Engineering Conferences, ASTME, 1966, 18 pp.
 114. ZLATIN, NORMAN; FIELD, MICHAEL; KOSTER, WILLIAM P.; ET AL.: Final Report on Machinability of Materials. Technical Report AFML-TR-65-444, Metcut Research Associates, Inc., Cincinnati, Ohio, Jan. 1966.
 115. KIRSCHBAUM, RAYMOND A.: Machining 18% Nickel Maraging Steel With Rotary Tools. Technical Report 65-3561, U.S. Army Weapons Command, Rock Island Arsenal, Research and Engineering Division, Rock Island, Ill., Dec. 1965.
 116. SALMON COX, P. H.; BIRKLE, A. J.; REISDORF, B. G.; AND PELLISSIER, G. E.: An Investigation of the Mechanical Properties and Microstructures of 18 Ni (250) Maraging Steel Weldments. *ASM Transactions Quarterly*, vol. 60, no. 2, June 1967, pp. 125-143.
 117. KAMMER, P. A.; AND MARTIN, D. C.: Welding High-Strength Steels. DMIC Report 229, Defense Metals Information Center, Battelle Memorial Institute, Columbus, Ohio, July 15, 1966.
 118. ROMINE, H. E.: Plane Strain Fracture Toughness of 18 Ni (250) and 18 Ni (200) Maraging Welded Steel Plate. Report 1959, U.S. Naval Weapons Laboratory, Dahlgren, Va., Jan. 8, 1965.
 119. ROMINE, H. E.: Relation of Oxygen Content to Fracture Toughness in 18 Ni Maraging Steel Welds. Technical Report No. 2033, U.S. Naval Weapons Laboratory, Dahlgren, Va., May 2, 1966.
 120. DUFFEY, F. D.; AND SUTAR, W.: Submerged-Arc Welding of 18% Nickel Maraging Steel. *Welding Journal*, vol. 44, no. 6, pp. 251S-263S, 1965.
 121. KNOTH, R. J.; AND LANG, F. H.: 18% Nickel Maraging Steel Metallurgy and Its Effects on Welding. *ASM Metals Engineering Quarterly*, vol. 6, May 1966, pp. 49-53.
 122. CANONICO, D. A.: Gas Metal-Arc Welding of 18% Nickel Maraging Steel. *Welding Journal*, vol. 43, no. 10, pp. 433S-442S, 1964.
 123. SAPERSTEIN, Z. P.: Evaluation of Maraging Steel for Application to Space Launch Vehicles. Report SM-43105, Douglas Aircraft Co., Inc., Santa Monica, Calif., NASA Contract NAS7-214, Feb. 1964.
 124. PETERSEN, W. A.: Weld Heat-Affected Zone of 18% Nickel Maraging Steel. *Welding Journal*, vol. 43, no. 9, pp. 428S-432S, 1964.
 125. EVANS, R. M.; AND MONROE, R. E.: The Current Status of the Welding of Maraging Steels. DMIC Memorandum 182, Defense Metals Information Center, Battelle Memorial Institute, Columbus, Ohio, Oct. 16, 1963.
 126. CRIMMINS, P. P.; AND TENNER, W. S.: How To Weld Thick Plates of 18% Ni Maraging Steel. *Metal Progress*, vol. 87, no. 5, pp. 57-62, 1965.
 127. ABBOTT, W. D.; AND BROOKS, L. A.: Investigation of Subarc, Excelco Big TIG, and Other Welding Processes on 18% Nickel Maraging Steel. Quarterly Report Cr 57856, Excelco Developments, Inc., Silver Creek, N.Y., NASA Contract NASw-687, Mar. 1965.
 128. Canadian Submission on New Developments and New Applications of Welding Techniques for High-Strength Steels, to Tripartite Technical Cooperation Program, Jan. 1965.

129. Canadian Submission on New Developments and New Applications of Welding Techniques for High-Strength Steels, to Tripartite Technical Cooperation Program, Jan. 1966.
130. COLBERT, L. E.: Design, Fabrication, and Hydrotesting of a 120-in.-Diameter Pressure Vessel Using 18% Ni Maraging Steel—Final Report. Report 609-F, Lockheed Propulsion Co., Redlands, Calif., Air Force Contract AF04(611)-8525, Oct. 2, 1964.
131. CRAIG, P. S.; AND SFORZINI, R. H.: Materials and Processes for a 156-in.-Diameter Monolithic Motor. Paper no. 65-164, Thiokol Chemical Corp., Brunswick, N.J., presented at AIAA 6th Solid Propellant Rocket Conference, Washington, D.C., Feb. 1-3, 1965.
132. VILKAS, E. P.; REYNOLDS, R. W.; AND LOUDEN, J. T.: Final Report on Development of Manufacturing Methods for TIG Welding. Technical Report AFML-TR-66-74, Sciaky Bros., Inc., Chicago, Ill., Apr. 1966.
133. FRAGETTA, W. A.; AND KRYSIAK, K. F.: HY-180/210 Maraging Steel Weldments: Suitability of Electron Beam and High Current Density TIG Processes. Report RE-65-037-CRE-34, Air Reduction Company, Murray Hill, N.J., Navy Contract NObs/88540, Apr. 23, 1965.
134. BONISZEWSKI, T.; AND KENYON, D. M.: Examination of Electron Beam Welds in 18% Ni/Co/Mo Maraging Steel Sheet. British Welding Journal, vol. 13, no. 7, July 1966, pp. 415-435.
135. SEABROOK, J. B.: Working With Maraging Steels—Nitriding. Metal Progress, vol. 84, no. 1, July 1963, pp. 78-80.
136. HAYNES, A. G.: Maraging Steels—Surface Protection and Surface Effects. Special Report 86, Metallurgical Developments in High Alloy Steels, The Iron and Steel Institute (British), pp. 125-133, 1964.
137. IMRIE, W. M.: An Assessment of Maraging Steel for Aircraft Applications. Journal of the Royal Aeronautical Society, vol. 70, no. 668, Aug. 1966, pp. 776-777.
138. GRAAE, A.: How To Nitride Maraging Steels. Metal Progress, vol. 92, no. 1, July 1967, pp. 74-76.
139. ASTM Designation: A538-65, Standard Specification for 18% Nickel Precipitation-Hardening (Maraging) Alloy Steel Plates for Pressure Vessels. ASTM Standards, pt. 4, pp. 818-821 (1967).
140. Aerospace Material Documents AMD 64 BL, AMD 64 BM, AMD 64 BN, AMD 64 BP-1, and AMD 64 BR-1. Society for Automotive Engineers, Inc., 485 Lexington Ave., New York, N.Y.
141. 18% Nickel Ultrahigh Strength Maraging Steels. Vanadium-Alloys Steel Co., Latrobe, Pa. (1966).
142. 260-in.-Dia. Motor Feasibility Demonstration Program, vol. 5: 260-SL Motor Chamber and Nozzle Shell Fabrication of 18 Ni Maraging Steel. Aerojet-General Corp., NASA CR-72126 (Apr. 8, 1966).
143. HOENIE, A. F.; ET AL.: Determination of Mechanical Property Design Values for 18 Ni-CoMo 250 and 300 Grade Maraging Steels. Report AFML-TR-65-197, North American Aviation, Inc., Contract AF33(615)-1209 (July 1965).
144. HEISER, F. A.: Effect of Exposure to Elevated Temperature on the Mechanical Properties of Maraging Steel. Technical Report, Watervliet Arsenal (June 1967).
145. CHRISTIAN, J. L.; YANG, C. T.; AND WITZELL, W. E.: Physical and Mechanical Properties of Pressure Vessel Materials for Application in a Cryogenic Environment. Report ASD-TR-62-258, pt. III, General Dynamics/Astronautics (Dec. 1964).
146. CAMPBELL, J. E.; BARONE, F. J.; AND MOON, D. P.: The Mechanical Properties of the 18% Nickel Maraging Steels. DMIC Report 198, Defense Metals Information Center (Feb. 24, 1964).
147. TUFFNELL, G. W.; PASQUINE, D. L.; AND OLSON, J. H.: An Investigation of the Fatigue Behavior of 18% Nickel Maraging Steel. ASM Transactions Quarterly, vol. 59, no. 4 (Dec. 1966).
148. BARRANCO, J. M.; ET AL.: The Effect of Microstructure and Aging Condition on the Fatigue Characteristics of the 18 Ni Maraging Steels. Watervliet Arsenal (May 1965).
149. ROLFE, S. T.; AND NOVAK, S. R.: Slow Bend K_{Ic} Testing of Medium-Strength High Toughness Steels. Technical Report, U.S. Steel Corp. Applied Research Laboratory, Contract NObs-94535 (FBM) SF020-01-01 (Aug. 1, 1967).
150. BROWN, W. F.; AND SRAWLEY, J. E.: Plane Strain Crack Toughness Testing of High-Strength Metallic Materials. ASTM Special Technical Publication No. 410, American Society for Testing and Materials, Philadelphia, Pa. (1966).
151. Evaluation of High Nickel Steel for Application in Large Booster Motor Fabrication. Technical Documentary Report no. ML-TDR-64-115, Aerojet-General Corp., Contract AF33(657)-8740 (Apr. 1964).
152. SRAWLEY, J. E.; AND ESGAR, J. B.: Investigation of Hydrotest Failure of Thiokol Chemical Corporation 260-Inch-Diameter SL-1 Motor Case. Report NASA TM-X-1194, Lewis Research Center (Jan. 1966).

153. GERMER, J.: Fabrication and Fracture Toughness of 0.020-Inch-Thick Maraging Steel Experimental Cases. Final report, The Budd Co., Contract DA-01-021-AMC-12524 (Z) (May 22, 1967).
154. DEAN, S. W.; AND COPSON, H. R.: Stress Corrosion Behavior of Maraging Nickel Steels in Natural Environments. *Corrosion*, vol. 21, no. 3, Mar. 1965, pp. 95-103.
155. 18% Nickel Maraging Steels. Summary Data, The International Nickel Co., Inc., New York, N.Y., Mar. 30, 1965, 8 pp.
156. BROWN, B. F.: Stress Corrosion Cracking and Related Phenomena in High-Strength Steels. NRL Report 6041, U.S. Naval Research Laboratory, Washington, D.C., Nov. 6, 1963.
157. FLETCHER, E. E.; BERRY, W. E.; AND ELSEA, A. R.: Stress Corrosion Cracking and Hydrogen-Stress Cracking of High-Strength Steel. DMIC Report 232, July 29, 1966, Defense Metals Information Center, Battelle Memorial Institute, Columbus, Ohio.
158. LOGAN, H. L.: *The Stress Corrosion of Metals*. John Wiley & Sons, Inc., New York, 1966, 306 pp.
159. BROWN, B. F.: A New Stress Corrosion Cracking Test for High-Strength Alloys. *Materials Research and Standards*, vol. 6, no. 3, Mar. 1966, pp. 129-133.
160. SETTERLUND, R. B.: Stress Corrosion Cracking of Maraging Steel. *Materials Protection*, Vol. 4, Dec. 1965, pp. 27-29.
161. SETTERLUND, R. B.: Stress Corrosion Cracking of High-Strength Alloys. Report no. 2684, Aerojet-General Corp., Azusa, Calif., Contract DA-04-495-ORD 3069, Sept. 1963.
162. PETERSON, M. H.; BROWN, B. F.; NEWBEGIN, R. L.; AND GROOVER, R. E.: Stress Corrosion Cracking of High-Strength Steels and Titanium Alloys in Chloride Solutions at Ambient Temperature. *Corrosion*, vol. 23, no. 5, May 1967, pp. 142-148.
163. SHIMMIN, J. T.; GLASGAL, BARRY; AND ODAR, J. A.: Manufacturing Process Development for High-Strength Steels. Technical Report AFML-TR-66-340, Republic Steel Corp., Central Alloy District, Canton, Ohio, Dec. 1966.
164. WACKER, G. A.: Stress Corrosion Cracking Studies of 10%, 12%, and 18% Nickel Maraging Steels in Seawater. MEL R&D Phase Report 73/66, U.S. Navy Marine Engineering Laboratory, Annapolis, Md., Mar. 1966.
165. NOVAK, S. R.; AND ROLFE, S. T.: K_{Ic} Stress Corrosion Tests of 12 Ni-5 Cr-3 Mo and 18 Ni-8 Co-3 Mo Maraging Steels and Weldments. Technical Report, Contract NObs-88540, Applied Research Laboratory, U.S. Steel, Monroeville, Pa., Jan. 1, 1966.
166. RUBIN, A.: Stress Corrosion Cracking of High-Strength Alloys. Report no. 2914, Aerojet-General Corp., Azusa, Calif., Aug. 1964.
167. LEGENDRE, P.: Some Properties of Maraging Steels. *Cobalt* No. 29, Dec. 1965, pp. 171-180.
168. DECKER, R. F.; NOVAK, C. J.; AND LANDIG, T. W.: Developments and Projected Trends in Maraging Steels. *Journal of Metals*, vol. 19, no. 11, Nov. 1967, pp. 60-66.
169. DREYER, G. A.; AND GALLAUGHER, W. C.: Investigation of the Effects of Stress Corrosion on High-Strength Steel Alloys. Report no. ML-TDR-64-3, Boeing Co., Airplane Division, Renton, Wash., Feb. 1964.
170. CROWNOVER, W. S.; AND WRIGHT, J. W.: Stress Corrosion Susceptibility of 18% Nickel Maraging Steels at High-Strength Levels. Report no. RK-TR-66-11, Propulsion Mechanics Branch, Propulsion Laboratory, Research and Development Directorate, U.S. Army Missile Command, Redstone Arsenal, Ala., July 13, 1966.
171. AGRICOLA, K. R.; AND SNYDER, J. T.: Stress Corrosion of Explosively Deformed High-Strength Alloys. *Metals Engineering Quarterly*, vol. 7, no. 3, Aug. 1967, pp. 59-63.
172. LOGINOW, A. W.: Stress Corrosion of Maraging Steel Weldments in Seawater. Technical Report, Contract NObs-94535 (FBM), Applied Research Laboratory, U.S. Steel Co., Monroeville, Pa., Aug 1, 1967.
173. SANDOZ, G.; AND NEWBEGIN, R. L.: Stress Corrosion Cracking of an 18 Ni 200 Grade Maraging Steel Base Plate and Weld. NRL Memorandum Report 1772, Naval Research Laboratory, Washington, D.C., Mar. 1967.
174. GRAY, H. R.; AND TROIANO, A. R.: How Hydrogen Affects Maraging Steel. *Metal Progress*, vol. 85, no. 4, Apr. 1964, pp. 75-78.
175. TOURKAKIS, H. C.; AND SONNINO, C. B.: Hydrogen Embrittlement of 250 Grade Maraging Steel. Report on the Fourth Maraging Steel Project Review, DMIC Memorandum 196, Defense Metals Information Center, Battelle Memorial Institute, Columbus, Ohio, Aug. 19, 1964.
176. HANNA, G. L., AND STEIGERWALD, E. A.: Influence of Environment on Crack Propagation and Delayed Failures in High-Strength Steels. RTD-TDR-63-4225, Thompson Ramo Wooldridge, Inc., Cleveland, Ohio, Jan. 1964.
177. JOHNSON, H. H.; AND WILLNER, A. M.: Moisture and Stable Crack Growth in a High-Strength Steel. *Applied Materials Research*, vol. 4, Jan. 1965, pp. 34-40.

178. BRISBANE, A. W.; HAWN, J. M.; AND AULT, R. T.: Fracture Toughness and Delayed Failure Behavior of 18% Nickel Maraging Steel. *Materials Research and Standards*, vol. 5, Aug. 1965, pp. 395-405.
179. GROENEVELD, T. P.; FLETCHER, E. E.; AND ELSEA, A. R.: A Study of Hydrogen Embrittlement of Various Alloys. Annual Summary Report, Contract no. NAS8-20029, Battelle Memorial Institute to NASA, George C. Marshall Space Flight Center, Huntsville, Ala., June 23, 1966.
180. GROENEVELD, T. P.; FLETCHER, E. E.; AND ELSEA, A. R.: A Study of Hydrogen Embrittlement of Various Alloys. Annual Summary Report, Contract no. NAS8-20029, Supplement 1, Battelle Memorial Institute to NASA, George C. Marshall Space Flight Center, Huntsville, Ala. June 23, 1967.
181. MIHALISIN, J. R.; AND BIEBER, C. G.: Progress Toward Attaining Theoretical Strength With Iron-Nickel Maraging Steels. *Journal of Metals*, vol. 18, no. 9, Sept. 1966, pp. 1033-1036.
182. DECKER, R. F.; NOVAK, C. J.; AND LANDIG, T. W.: Developments and Projected Trends in Maraging Steels. *Journal of Metals*, vol. 19, no. 11, Nov. 1967, pp. 60-66.

Bibliography

- AUSTIN, C. W., JR.: Mechanical Behavior of 18Ni-7Co-5Mo (250 ksi) Maraging Steel Under Biaxial Stress and Rapid Heating. Report RR-TR-65-12, Redstone Arsenal (Aug. 1965).
- AUSTIN, C. W. JR.: Short-Time Creep Behavior of 18-Nickel (250 ksi) and 18-Nickel (300 ksi) Maraging Steel Under Uniaxial Tensile and 1:2 Tension-Tension Biaxial Loading. Report RR-TR-67-2, Redstone Arsenal (Jan. 17, 1967).
- BARTON, C. J.; ET AL.: Investigation of Thermal Embrittlement in 18 Ni (250) Maraging Steel. U.S. Steel Corp., Contract AF33(615)-2780 (Second Quarterly Progress Report is dated Mar. 31, 1966).
- Data on Some Republic Steel Consumable Electrode Vacuum Arc Remelt Steels. Republic Steel Corp. (Nov. 1967).
- DECKER, R. F.; ET AL.: Developments and Projected Trends in Maraging Steels. Journal of Metals, pp. 60-66 (Nov. 1967).
- FREED, C. N.: Plane Strain Fracture Toughness of High and Ultrahigh Strength Materials. NRL Report 6554, Naval Research Laboratory (Apr. 1966).
- GARLAND, C.: Fabricating Maraging Steel, Paper no. 540-1 for Northeastern States Naval Research and Development Clinic, Philadelphia, Nov. 18-20, 1964.
- IANNELLI, A. A.; AND RIZZITANO, F. J.: Notched Properties of High-Strength Alloys at Various Load Rates and Temperatures. Report AMRA-TR66-13, Army Materials Research Agency (July 1966).
- KENDALL, D. P.; AND DAVIDSON, T. E.: The Effect of Strain Rate on Yielding in High-Strength Steels. Report WVT-6618, Watervliet Arsenal (May 1966).
- KIES, J. A.; SMITH, H. L.; AND ROMINE, H. E.: Fracture Toughness and Critical Defect Sizes With Welds of 18% Nickel Maraging Steels. ASM Metals Engineering Quarterly, vol. 6, no. 4, pp. 37-47 (Nov. 1966).
- Manufacturing Process Development for High-Strength Steels. Technical Report AFML-TR-66-340, Manufacturing Technology Laboratory, Wright-Patterson Air Force Base, Contract AF33(657)-11277 (Dec. 1966).
- SPAEDER, G. J.; ET AL.: The Effect of Hot Rolling Variables on the Fracture Toughness of 18 Ni Maraging Steel. Transactions Quarterly, vol. 60, no. 3, pp. 418-425, American Society for Metals (Sept. 1967).
- WEISS, V.; AND SESSLER, J. G.: Aerospace Structural Metals Handbook, Vol. I, Third Revision, Ferrous Alloys. Syracuse University Research Institute, Syracuse, N.Y., Contract AF33(615)-11848, Syracuse University Press (Mar. 1966).

NATIONAL AERONAUTICS AND SPACE ADMINISTRATION
WASHINGTON, D. C. 20546
OFFICIAL BUSINESS

POSTAGE AND FEES PAID
NATIONAL AERONAUTICS AND
SPACE ADMINISTRATION

FIRST CLASS MAIL

04U 001 42 55 4ES 69046 68364 01195
BATTELLE MEMORIAL INSTITUTE
DEFENSE METALS INFORMATION CENTER
COLUMBUS LABORATORIES
505 KING AVE.
COLUMBUS, OHIO 43201
ATT ROGER J. RUNCK

MISSSENT TO NORTH AMERICAN ROCKWELL
CORPORATION

POSTMASTER: If Undeliverable (Section 158
Postal Manual) Do Not Return

"The aeronautical and space activities of the United States shall be conducted so as to contribute . . . to the expansion of human knowledge of phenomena in the atmosphere and space. The Administration shall provide for the widest practicable and appropriate dissemination of information concerning its activities and the results thereof."

— NATIONAL AERONAUTICS AND SPACE ACT OF 1958

NASA TECHNOLOGY UTILIZATION PUBLICATIONS

These describe science or technology derived from NASA's activities that may be of particular interest in commercial and other non-aerospace applications. Publications include:

TECH BRIEFS: Single-page descriptions of individual innovations, devices, methods, or concepts.

TECHNOLOGY SURVEYS: Selected surveys of NASA contributions to entire areas of technology.

OTHER TU PUBLICATIONS: These include handbooks, reports, notes, conference proceedings, special studies, and selected bibliographies.

Details on the availability of these publications may be obtained from:

National Aeronautics and
Space Administration
Code UT
Washington, D.C. 20546

Technology Utilization publications are part of NASA's formal series of scientific and technical publications. Others include Technical Reports, Technical Notes, Technical Memorandums, Contractor Reports, Technical Translations, and Special Publications.

Details on their availability may be obtained from:

National Aeronautics and
Space Administration
Code US
Washington, D.C. 20546

NATIONAL AERONAUTICS AND SPACE ADMINISTRATION
Washington, D.C. 20546