

FINAL REPORT

**A Feasibility Study and Experimental Evaluation
on MHD Acceleration for Application to
Advanced Propulsion and Hypervelocity Ground
Testing
(Delivery II)**

**Prepared for: The European Office of Aerospace Research
and Development (EOARD) under Contract
F61775-00WE031**

1.03.2000—1.06.2000

Principal Investigator: Dr.Valentin A.Biturin

**Moscow
July 2000**

20000727 143

REPORT DOCUMENTATION PAGE

Form Approved OMB No. 0704-0188

Public reporting burden for this collection of information is estimated to average 1 hour per response, including the time for reviewing instructions, searching existing data sources, gathering and maintaining the data needed, and completing and reviewing the collection of information. Send comments regarding this burden estimate or any other aspect of this collection of information, including suggestions for reducing this burden to Washington Headquarters Services, Directorate for Information Operations and Reports, 1215 Jefferson Davis Highway, Suite 1204, Arlington, VA 22202-4302, and to the Office of Management and Budget, Paperwork Reduction Project (0704-0188), Washington, DC 20503.

1. AGENCY USE ONLY (Leave blank)		2. REPORT DATE July 2000	3. REPORT TYPE AND DATES COVERED Final Report	
4. TITLE AND SUBTITLE A Feasibility Study and Experimental Evaluation on MHD Acceleration for Application to Advanced Propulsion and Hypervelocity Ground Testing			5. FUNDING NUMBERS F61775-00-WE031	
6. AUTHOR(S) Dr. Valentin Bityurin				
7. PERFORMING ORGANIZATION NAME(S) AND ADDRESS(ES) Russian Academy of Sciences IVTAN, Izhorskaya str., 13/19 Moscow 127412 Russia			8. PERFORMING ORGANIZATION REPORT NUMBER N/A	
9. SPONSORING/MONITORING AGENCY NAME(S) AND ADDRESS(ES) EOARD PSC 802 BOX 14 FPO 09499-0200			10. SPONSORING/MONITORING AGENCY REPORT NUMBER SPC 00-4031	
11. SUPPLEMENTARY NOTES				
12a. DISTRIBUTION/AVAILABILITY STATEMENT Approved for public release; distribution is unlimited.			12b. DISTRIBUTION CODE A	
13. ABSTRACT (Maximum 200 words) This report results from a contract tasking Russian Academy of Sciences as follows: The contractor will conduct initial feasibility and analysis studies on the application of MHD accelerator for propulsion and flow acceleration. The overall objective of the proposed project is to perform preliminary testing in order to evaluate an experimental MHD accelerator laboratory that can be used in the future for both experimentation into MHD propulsion and as a hypervelocity wind tunnel for experiments into hypersonic flow and flight control systems. Within the confines of the proposed program, the contractor seeks to: a) analyze and report on the potential/capability of MHD acceleration assisted advanced propulsion and to provide quasi-steady state hypervelocity ground tests; 2) evaluate an existing experimental MHD accelerator laboratory for experimental testing and 3) develop an experimental plan for conduct of an open demonstration experiment.				
14. SUBJECT TERMS EOARD, Magnetohydrodynamic (MHD), Propulsion, Hypersonics			15. NUMBER OF PAGES 33	
			16. PRICE CODE N/A	
17. SECURITY CLASSIFICATION OF REPORT UNCLASSIFIED	18. SECURITY CLASSIFICATION OF THIS PAGE UNCLASSIFIED	19. SECURITY CLASSIFICATION OF ABSTRACT UNCLASSIFIED	20. LIMITATION OF ABSTRACT UL	

NSN 7540-01-280-5500

DTIC QUALITY INSPECTED 4

Standard Form 298 (Rev. 2-89)
Prescribed by ANSI Std. Z39-18
298-102

CONTENTS

PART-I

INTRODUCTION (STATEMENT OF WORK)

1. Motivation
2. Project Objectives
3. Project Plan
4. Facilities and Equipment

I. CURRENT STATE AND POTENTIALITIES OF HYPERSONIC MHD-GAS ACCELERATION WIND TUNNELS

1. Introduction
2. Main Components of an MHD Wind Tunnel
 - 2.1. Hot Gas Source
 - 2.2. Seed Injection Methods
 - 2.3. Primary Nozzle
 - 2.4. MHD-Channel
3. Numerical Simulation
 - 3.1. Calculation of Gas Flows in MHD-Channel
 - 3.2. Flow Calculation in the Secondary Nozzle
4. Experiments with MHD WT
 - 4.1. Experimental Investigation of Flow Parameters
 - 4.2. Application of Hypersonic MHD-Gas Acceleration Wind Tunnels to Aerodynamic Experiments
 - Visualization
 - Seed Effects
 - Code Validation
 - Non-Perfect Gas Effects
 - Scramjet Simulation
 - Operational Map
 - Future Facility

CONCLUSION PART-I

REFERENCES PART-I

PART-II

1. Description of the test rig
2. Modernized gas exhaust system
3. List of works for systems and units subjected to preventive maintenance and repair
4. Selected parameters and operation regimes of the test rigs during adjustment runs
 - Parameters of the flow and electrical circuits
5. Data acquisition system of the MHD-gas acceleration test rig
 - Technical characteristics of main components of the data acquisition system
 - Characteristics of personal computer (IBM-PC/AT type)
 - Dedicated software (first queue)
6. Calculation of gas flow in the MHD-channel
 - Calculation of flow parameters during check runs
7. The results of the work

CONCLUSION AND FUTURE WORK PROPOSALS

ACKNOWLEDGMENTS

REFERENCES PART-II

PART-I

**MHD and Low Temperature Plasma Division
Institute of High Temperatures of
Russian Academy of Sciences**

REPORT (PART I)

**A Feasibility Study and Experimental Evaluation
on MHD Acceleration for Application to
Advanced Propulsion and Hypervelocity Ground
Testing
(Delivery I)**

**Prepared for: The European Office of Aerospace Research
and Development (EOARD) under Contract
F61775-00WE031**

1.03.2000—1.06.2000

Principal Investigator: Dr. Valentin A. Bityurin

**Moscow
July 2000**

CONTENTS

INTRODUCTION (STATEMENT OF WORK)

1. Motivation
2. Project Objectives
3. Project Plan
4. Facilities and Equipment

I. CURRENT STATE AND POTENTIALITIES OF HYPERSONIC MHD-GAS ACCELERATION WIND TUNNELS

5. Introduction
6. Main Components of an MHD Wind Tunnel
 - 2.1. Hot Gas Source
 - 2.2. Seed Injection Methods
 - 2.3. Primary Nozzle
 - 2.4. MHD-Channel
7. Numerical Simulation
 - 3.1. Calculation of Gas Flows in MHD-Channel
 - 3.2. Flow Calculation in the Secondary Nozzle
8. Experiments with MHD WT
 - 4.1. Experimental Investigation of Flow Parameters
 - 4.2. Application of Hypersonic MHD-Gas Acceleration Wind Tunnels to Aerodynamic Experiments
 - Visualization
 - Seed Effects
 - Code Validation
 - Non-Perfect Gas Effects
 - Scramjet Simulation
 - Operational Map
 - Future Facility

CONCLUSION

REFERENCES

INTRODUCTION (STATEMENT OF WORK)

MOTIVATION

Renewed scientific interest has arisen throughout the world as to the potential application of MHD processes for advancement of flight. Specific to this are the collaborative research works going on between the US and IVTAN in the field of electromagnetic (EM) Advanced Flow and Flight Control for hypersonic aircraft and single-stage earth-to-orbit vehicles. Among the areas of interest is that of utilization of MHD as a means for enhancing the speed and range of scramjets through a concept known as MHD energy by-pass [1-4]. Currently, scramjet operation is limited to free stream flight Mach numbers around 10. This limitation arises from the excessive temperature that develops at high Mach conditions as a result of the slowing down of the propulsion drafted hypersonic air stream within the propulsion system inlet. High temperature air ($> 1,600\text{K}$) entering the scramjet combustor inhibits combustion due to the natural dissociation of chemical species that occurs.

The MHD energy-bypass concept is a two stage process. First it employs an MHD generator situated in the inlet to extract enthalpy from the propulsion air stream to cool the flow prior to entering the scramjet. This extracted thermal energy is converted to electrical power through the MHD generator process of electromagnetic induction. With the scramjet combustor incoming flow cooled, the flight corridor of the aircraft can be enhanced to higher Mach number. In the second stage of this process, the electric power extracted by the generator is used to power an MHD accelerator in the propulsion systems tailpipe. The tailpipe MHD accelerator is the generator process in reverse (motor mode of operation) and results in adding energy directly back to the stream flow as kinetic energy through the action of Lorentz forces. Consequently, the flow energy extracted in the inlet generator is recovered in the tailpipe MHD accelerator, negating/cancelling dynamic stream losses.

The figure 1 exemplifies the MHD energy-by pass concept.

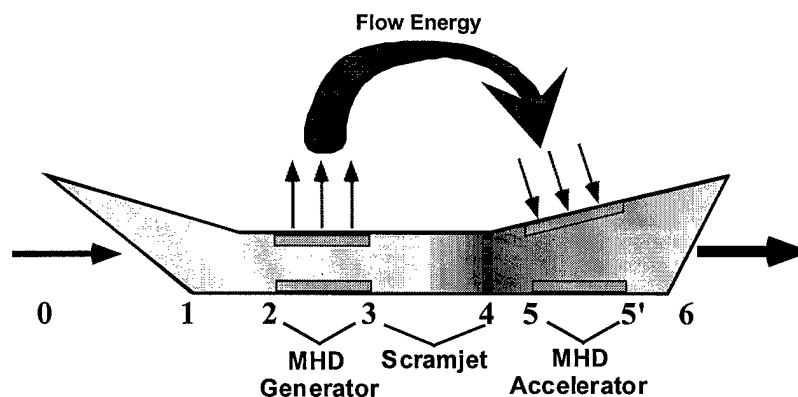

Fig.1. Schematic of MHD energy by pass concept.

A potential area of collaboration has recently arisen between IVTAN and NASA's Advanced Space Transportation Program (ASTP). NASA ASTP is interested in this propulsion concept as a potential new system for single-stage-to-orbit vehicles. Collaborative studies done by Dr. V.A. Bityurin of IVTAN and a U.S. Small Company, LyTec, LLC have screened the thermodynamics of the MHD energy by-pass concept [5-7]. The promising results of that work have led to increased interest by NASA ASTP to explore operation of components of this system in experiments.

One of the key, and least understood components of the system is the MHD accelerator. Expertise and experience in this area does exist at IVTAN TsAGI and our US counterparts recognize our unique knowledge in this field. In addition, IVTAN has readily available access to an operational MHD accelerator that can be used as a test bed. In anticipation of the follow-up collaborative program with NASA ASTP (currently being requested through the agency's international programs), we have proposed to EOARD an initial effort in the exploration of MHD acceleration for aerospace. Our proposed accelerator project is equally applicable to exploring MHD propulsion and to utilizing MHD acceleration as a flow driver for hypersonic ground testing.

Our intention under this proposed project was to conduct some initial feasibility and analysis studies on application of the MHD accelerator for propulsion and flow acceleration. In this analytical effort, we plan to analyze the MHD acceleration process as a means to improve our understanding of this type of device and to qualify its application to MHD energy by-pass propulsion. This work is a prelude to the collaborative IVTAN-NASA follow-on program that will be both experimental and theoretical. In addition, we use this proposed EOARD work as a vehicle to make the experimental MHD accelerator facility operational. The facility we have utilized is an MHD accelerator driven wind tunnel that been idle since 1995. We envisioned that it would require approximately two and one half months of technician and engineering effort to refurbish the tunnel to operational status. This anticipation has been fully confirmed by the proposed work done.

Our proposed project will be to the benefit of all parties involved, present and future. The MHD accelerator test facility now operational provides a working prototype that can be directly researched to qualify the MHD accelerator for potential application to advanced propulsion concepts of interest to NASA and others. This laboratory readiness effort makes available a hypervelocity wind tunnel that can be used as a test bed by others (US Air Force and US industries) in the wider range of programs and initiatives that are taking place in exploration of EM Advanced Flow and Flight Control. Indeed, our proposed project falls well within the mission of the EOARD of expanding the U.S. and Russian scientific cooperation and resources for revolutionary, breakthrough aeronautical research.

PROJECT OBJECTIVES

The overall objective of our proposed project was to make ready ("wet") an experimental MHD accelerator laboratory that can be used in the future for both experimentation into MHD propulsion and as a hypervelocity wind tunnel for experiments into hypersonic flow and flight control systems. Within the confines of our proposed program we seek to achieve the following specific technical objectives:

- 1. To analysis and report on the potential/capability of MHD acceleration assisted advanced propulsion and to provide quasi-steady state hypervelocity ground tests;*
- 2. To ready an existing experimental MHD accelerator laboratory for experimental evaluations;*
- 3. To develop an experimental plan for conduct of an open demonstration experiment.*

PROJECT PLAN

The following Table provides the work breakdown structure and brief descriptions of the discrete tasks of our Project Plan.

Task	Description
1.0 Background Studies	<ul style="list-style-type: none"> ● Conduct Literature Reviews on the MHD Acceleration Process and Past Experiments
2.0 Analysis	<ul style="list-style-type: none"> ● Conduct Literature Reviews on MHD acceleration and Past Experimentation ● Develop Methods for Analysis of MHD Accelerators ● Provide Analytical Support to Experimental Planning and Interpretation of Experimental Results
Task	Description
3.0 Lab Qualification and Preparation	<ul style="list-style-type: none"> ● Qualify Test Worthiness of Available Laboratory Hardware and Equipment ● Re-furbish Laboratory to Operational Status ● Define and Implement Diagnostics and Support Data Systems ● Define, Design, Fabricate Test Hardware Models
4.0 Experimental Plan	<ul style="list-style-type: none"> ● Define Basic Experimental Approach(s) – Test Conditions and Run Scenarios ● Develop Pre-Test Analytical Predictions ● Develop a Detailed Test Plan for Conduct of a Open Demonstration Experiment
5.0 Program Plan	<ul style="list-style-type: none"> ● Develop an Overall Program Plan for Conduct of Demonstration Experiment ● Co-ordinate Program Plan with Potential Facility Users
6.0 Reporting	<ul style="list-style-type: none"> ● Draft a Final Report Detailing the Facility and Its Capabilities as Project Deliverable

FACILITIES AND EQUIPMENT

A unique MHD accelerator of TsAGI laboratory headed by prof. V.Alfyorov has been made available through IVTAN. The laboratory has been made operational within a few months after project initiation through standard re-furbishment work under Task 3.0.

I. CURRENT STATE AND POTENTIALITIES OF HYPERSONIC MHD-GAS ACCELERATION WIND TUNNELS

1. INTRODUCTION

Developments of hypersonic wind tunnels with MHD-gas accelerators were initiated late in the 1950s when limited capabilities of classical hypersonic wind tunnels based on the test gas acceleration due to its adiabatic expansion became obvious. These studies were started almost at the same time in the USA (NASA, Langley Research Center, AEDS, General Electric Company) and in Russia (TsAGI). Some works were carried out in France (ONERA) and in Germany.

The present review analyzes different designs of such facilities. Main characteristics of the hypersonic wind tunnel of TsAGI and the results of its application to solve practical problems of aerodynamics are considered. The flow conditions over bodies in a free flight are compared with those realized experimentally in the test section of the facility at the same flow velocities of $V \sim 8 \text{ km/s}$. The advantage of applying MHD-gas acceleration facilities to solve problems of developing and testing scramjets for TAV vehicles is demonstrated and the data on possible gas dynamic and electrodynamic parameters of these facilities and their design versions are presented. Finally, basic problems to be solved in developing hypersonic MHD-gas acceleration facilities are listed.

The aerospace engineering was progressing simultaneously with the development of facilities intended for testing novel vehicles or their models in ground laboratory stands.

Before the middle 50s, hypersonic wind tunnels were based on the principle of converting the total stagnation enthalpy into the kinetic flow energy during gas expansion in a supersonic nozzle. The programs of piloted Earth reentry after the flight to the Moon in early 60s have posed the problem of constructing facilities capable of reproducing flow parameters at $M \sim 20-25$ and $Re \sim 10^7-10^8$ with an energy flow density of $\sim 10^7 \text{ m}^2/\text{s}^2$. At that time, it became clear that the capabilities of classical wind tunnels to solve this problem were limited. An important limitation on obtaining high parameters of the flow with a velocity of $V \sim 5-7 \text{ km/s}$ was the attainment of stagnation parameters $P_0 > 10^8 \text{ Pa}$ and $T_0 > 10000-12000 \text{ K}$ in the wind tunnel plenum chamber when growth of radiation losses (gas radiates as a black body) and break-down of the nozzle throat for the time less than 10^{-3} s are governing factors. Besides, high stagnation parameters led inevitably to non-equilibrium gas flows in hypersonic nozzles.

A way of increasing flight parameters to be simulated without achieving ultrahigh parameters in the facility plenum chamber is the method of magnetogasdynamic gas acceleration enabling a direct increase in the kinetic flow energy under the action of the Lorentz forces. Various MHD-accelerators were also proposed for wind tunnels, among which were accelerators with a travelling electromagnetic wave, Hall-type and Faraday-type accelerators. Each of them was characterized by its own operating range of flow density. For the first accelerator, it was $\rho = 10^{-7}-10^{-4} \text{ kg/m}^3$, for the second one $\rho = 10^{-6}-$

10^{-2}kg/m^3 , and finally, for the Faraday-type one $\rho=10^{-2}-10\text{kg/m}^3$. The Faraday-type MHD-accelerators implying the Hall current neutralization by means of electrode sectionalization received the widest recognition because the facilities providing maximum possible high flow densities are of particular interest for aerodynamic investigations. The simulation of hypersonic flights necessitates a correct reproduction of the following conditions:

1. Flight velocity
2. Mach number
3. Small initial oxygen dissociation level
4. Correct Damkohler number correlation for flows in the test section and in full-scale conditions
5. Rather great run duration to solve problems of experimental investigations.

The choice of basic accelerator characteristics depends on test objectives.

Essentially all hypersonic MHD-gas acceleration wind tunnels being developed in the early 60s have the following conceptual design (Fig.2).

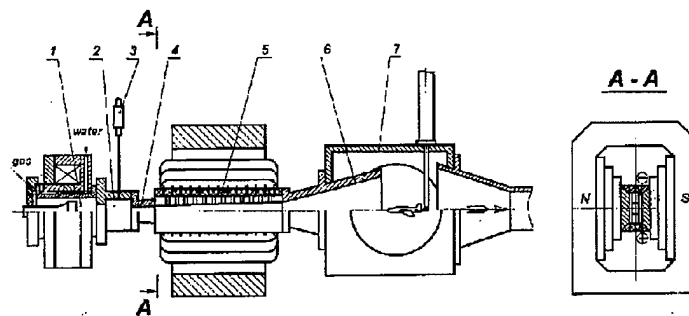

Fig.2. Schematic of MHD-gas acceleration wind tunnel. 1 – arc-heater, 2 – mixing chamber, 3 – metering device, 4 – primary supersonic nozzle, 5 – MHD-accelerator, 6 – secondary nozzle, 7 – test section

A gas (air, nitrogen etc.) heated in the source of a hot gas up to $T_0 \sim 3500-4000\text{K}$ and added with alkali seeds expands in a primary supersonic nozzle up to $M=1.8-2.5$ to enter a sectionalized Faraday-type MHD-channel. The quantity of electrodes with independent power sources amounts to $\sim 30-120$. The magnetic field with induction of $B \sim 1.5-5\text{T}$ is applied perpendicularly to the flow so that to provide the Lorentz force accelerating the gas. In a secondary hypersonic nozzle behind the MHD-channel, the Mach number increases from 3–4 to 15–20 as a result of adiabatic cooling and conversion of static enthalpy into velocity. Test models are installed in the test section, while supersonic and subsonic diffusers, a cooler and an exhaust system are mounted behind the test section. Either a vacuum reservoir or an ejector system are used as an exhaust system. Fig.2 shows the schematic of the facility.

Below consideration is given to physical processes proceeding in the components of the above outlined facility and to designs of its units used in different organizations.

2. MAIN COMPONENTS OF AN MHD WIND TUNNEL

2.1. Hot Gas Source

A hot gas source should provide required temperature and pressure levels sufficient to achieve a high-temperature flow with a minimum initial gas dissociation degree at the primary nozzle exit. Besides, flow fluctuations in it must be minimized. The level of stagnation parameters is governed by a characteristic operation time and a type of a source used. The greatest stagnation parameters $P_0=14 \cdot 10^7 \text{Pa}$ and $T_0=9000 \text{K}$ with an operation time of 10^{-3}s are attained in the case of employing an impulse wind tunnel plenum chamber as a hot gas source [8], while $T_0 \sim 6800 \text{K}$ and $P_0 \sim 10^8 \text{Pa}$ are obtained when application is given to a region behind a reflected shock wave in a shock wind tunnel [9,10]. Various arc heater designs are used to achieve stationary acceleration regimes, for example, heaters with a coaxial electrode arrangement [11-13], with an extended arc [14] etc. The temperature and pressure ranges in them are $P_0=(2-20) \cdot 10^5 \text{Pa}$ and $T_0 \sim 3500-6000 \text{K}$, the heater power is 0.2-2MW and mass flow rate through the heater is 0.02-0.25kg/s. Nitrogen and air are used as a test gas. The stagnation parameters in stationary sources of conducting gases can be increased up to $P_0 \sim 2 \cdot 10^7 \text{Pa}$, $T_0 \sim 5000 \text{K}$. Some experience in operation with similar heaters is gained both in Russia and in the USA.

To provide an optimal MHD-accelerator operation, the accelerator efficiency defined as the ratio of additional mechanical energy to the Joule dissipation function $\eta = jBU/jE$ should be maximum. The efficiency η increases with $\sigma B^2 L$, therefore, minimum possible altitudes should be simulated using a maximum possible value of $\sigma B^2 L$ when conduction is sufficient to have a satisfactory current density in the acceptable range of electric field intensities. Almost in all publications the value $\sigma = 100 \text{mo/m}$ is set as a lower limit. In order to ensure this limit it is necessary to inject alkali seeds into the gas.

2.2. Seed Injection Methods

The method of seed injection and provision for seed uniformity in a flow govern, to a large extent, the characteristics of a MHD-accelerator. There are several ways of injecting seeds: using a powder-type K_2CO_3 gas or a liquid solution of K_2CO_3 or KOH , applying NaK eutectics and supplying K , Cs . Seeds in the form of aerosols are employed for impulse systems. The fraction of total seed mass is varied from 3% to 0.5-0.3%. The tests in [11] and [12] show that seeds in the form of 1% NaK , 1% K , KOH do not exert significant effect on the flow characteristics. In a number of previous publications, erosion properties of seeds are pointed out which seem to be caused by incomplete seed evaporation. Supplying seeds in the form of liquid metal aerosol through atomizers into a high-temperature oxidizing medium, which a hot air is, results, during contacts with it, in formation of oxides choking the duct. To avoid it, the ducts should be blown through by a neutral gas prior to and post metal supplying. The seed supply area should be chosen so that a uniform seed distribution in the flow be provided and seed ingress into the heater discharge zone be excluded. To do this, it is preferential to use a special mixing chamber [15] with dimensions sufficient for metal aerosol evaporation. The characteristic metal aerosol evaporation time is $\sim 10^{-3}-10^{-2} \text{s}$. In future MHD-accelerators it seems to be reasonable to inject seeds in the form of alkali vapor.

Note that methods of providing non-equilibrium conduction using various preionizers are also considered in the literature. Possible methods can involve photoionization, high-frequency discharge, radiometric method, glow discharge and ionization by electron beam. But in spite of a 30-year discussion, these methods did not yet achieve the level of practical implementation [16-18].

There are two aspects of the seed effect on the characteristics of aerodynamic flows. Seed distribution in a gas, seed effect on thermodynamic medium properties and especially on chemical process rates, on deactivation of vibrational degrees of freedom of nitrogen and oxygen. A uniform seed distribution is ensured by seed supplying into the mixing chamber from a metering device through atomizers providing its fine spraying ($\sim 10\text{--}20\mu\text{m}$) and evaporation before entering the primary nozzle. The NaK atom distribution uniformity in the flow can be evaluated using intensities of their resonance fluorescence excited by laser radiation with a resonance wavelength. According to tests carried out at TsAGI (Fig.4), a uniform seed distribution in a flow is quite possible. Because of a low ionization potential and a small partial seed pressure in thermodynamic equilibrium the seed presence can be manifested in the form of some additional energy sink into internal degrees of freedom within the range of temperatures and pressures at which physico-chemical processes in air (excited vibrations and dissociation) proceed weakly. The seed effect on entropy, dissociation degree, sound velocity, viscosity is insignificant, while specific heat capacity and heat transfer coefficient are affected to a greater extent [19]. The seed influence on deactivation of vibrational degrees of freedom and chemical reactions will be analyzed below.

2.3. Primary Nozzle

The investigation of primary nozzle characteristics shows that the most optimal range of Mach numbers at the MHD-channel entry is within $M=1.8\text{--}2.2$. At lower Mach numbers, there occurs some flow instability at the MHD-channel entry, while at higher Mach numbers the static temperature becomes insufficient to provide conduction, and a required increase in the stagnation temperature in the conducting-gas source results in flow contamination by the electrode materials because of electrode erosion.

According to the theoretical and experimental data, the primary nozzle flow in all accelerators subjected to study is in thermodynamic equilibrium. In [15], use is made of contoured primary nozzles with a gradientless uniform velocity field at the exit.

2.4. MHD-Channel

The gas flow in the Faraday-type accelerator MHD-channel differs fundamentally from flows in the MHD-generator. The matter is that the MHD-channel is much more stressed in terms of energy. The flow at the channel entry features a supersonic Mach number exceeding typical values for the generator and much higher stagnation enthalpy ($\sim 2\text{--}3$ times). The current density in the flow is respectively higher ($j\sim 50\text{A}/\text{cm}^2$) at magnetic induction values of $B=1.5\text{--}5.0\text{T}$ and more, the Hall parameter being $w_e\tau_e\sim 3\text{--}20$. Combining the flow acceleration and temperature rise in the accelerator results in a great increase in the stagnation enthalpy as compared to the initial one (4–6 times). At

the MHD-channel exit, the Mach flow number can exceed $M \geq 4$. Under these conditions, a maximum flow temperature is attained in the boundary layer near the wall (recovery temperature). Because of the current concentration near the electrodes, the Joule gas heating at low temperatures immediately near the wall brings additionally a high-temperature and, accordingly, a high-conducting region closer to the surface. The gas density in this region is much less than that in any other flow parts. Because the accelerating Lorentz force is a volume force the gas in this region acquires a greater velocity than the main flow which is favorable for the flow pattern. On the other hand, the same phenomenon increases considerably the boundary layer displacement thickness as compared to an ordinary gas dynamic increase. A great potential drop across the cold sublayer of the boundary layer gives rise to phenomena similar to electrical break-down followed by the formation of microarcs. Although this phenomenon is well known in the extensive literature devoted to microarc investigations in MHD-generators [20-21] and in MHD-accelerators, it has its peculiar features [22-24].

In the MHD-accelerator, the arcs on the cathode occur and concentrate basically at its upstream end. Under the action of gas dynamic forces they are carried away at a mean velocity of ~ 10 m/s, extinguish and then occur again at the leading edge. A characteristic current in an individual arc is 5–10 A. The quantity of microarcs increases with rising the current strength per electrode. The anode microarcs are stationary to be placed at the joint of the anode trailing edge with the interelectrode insulator thus causing intense anode erosion. The current layers of high conduction lie, as a rule, behind the anode arcs to be a peculiar kind of gas electrodes. This phenomenon is similar to that taking place in electric discharge glow in a supersonic flow [25]. The current can move along these layers by large distances thus shunting individual electrodes [24]. From the above outlined phenomena it is inferred that a maximum fine MHD-channel sectionalization is desirable and the microarc discharge motion control in the channel is obligatory. The volt-ampere characteristics of the channel discharge gap are given in [26] and [27]. They are not volt-ampere characteristics in the classical understanding because gas dynamic flow parameters U , T , σ , P vary as the current strength rises. Note that the volt-ampere characteristics of the accelerator obtained at AEDC, USA differ qualitatively from those found at TsAGI, Russia. At AEDC, the characteristics feature an increasing behavior, while at TsAGI they are almost flattened, i.e., voltage increases slightly with rising the current strength. The lack of gas dynamic data for the AEDC accelerator makes it impossible to clarify causes of the difference.

2.5. MHD-Channel Designs

MHD-channel designs developed at different organizations differ noticeably to depend on a chosen type of the conducting-gas source and the acceleration process duration. The common point for all channels is the Faraday scheme consisting of a quadrangular channel with two insulated walls and two electrode walls having sectionalized electrodes and a stand-alone electric power source. The quantity of electrodes in the channel is from 3–5 to 120 at different organizations. Extensive studies were carried out to choose materials for electrodes and insulators. Most suitable materials for electrodes under the above conditions proved to be copper and its alloys, while boron, silicon and aluminium nitrides and beryllium oxide deposited on the cooled surfaces were chosen

for insulators. In stationary facilities, the tests were conducted at static pressures of $0.05\text{--}0.5\cdot 10^5\text{Pa}$ and magnetic induction of $B=1.5\text{--}2.5\text{T}$, i.e., at values provided by the magnets with iron core. In impulse facilities ($\tau\sim 10^{-3}\text{--}10^{-2}\text{s}$), the pressures were $P\sim 5.5\cdot 10^5\text{Pa}$ and $B=4\text{--}5\text{T}$. In all channels, the conductivities were within the range of $\sigma\sim 100\text{--}400\text{mo/m}$, current densities through electrodes for stationary and impulse MHD-accelerators were $20\text{--}60\text{A/cm}^2$. At $j>60\text{A/cm}^2$, intense electrode erosion was noted. It is usual to point out a mean current density based on the electrode area without consideration of the current concentration at the electrode-insulator joint. The electrodes and insulating walls were made in two modifications: with water cooling and without it. In the modification without water cooling they provide heat accumulation in their structures, their operation time being restricted by attaining the insulator surface temperature corresponding to melting or evaporation. In publication [15], this time for uncooled structure is $\sim 1\text{s}$. If the structure is cooled by water, as is the case in [11-12], the time is $\sim 10\text{s}$ and more. In similar structures, the performance of cooled copper electrodes, as well as of cooled insulators made from a thin film of beryllium oxide deposited on the metal is good. It is known that among insulators the beryllium oxide features the highest heat conduction and the smallest increase in conduction as the temperature rises. The channels were equipped with probes to measure pressure distributions along the anode and cathode walls, as well as transducers for voltage and current strength. There is no data so far about potential measurements inside the MHD-channel of the accelerator. In almost all structures, the channel is made slightly divergent to compensate for the boundary layer growth, the range of divergence angles being $0.3\text{--}1.5^\circ$. There exist channels with both divergent electrode wall only and all divergent walls.

2.6. Electric Power Supply for Electrodes and Magnets

50–100 stand-alone electric power sources providing the current of $\sim 50\text{--}100\text{A}$ and voltage $\sim 300\text{--}1000\text{V}$ are required for MHD-accelerator electrodes, the insulators being designed for voltage of $1\text{--}5\text{kV}$. In stationary systems, use was made of accumulator batteries, high-voltage transformers with disconnected coil winding at the high-voltage side in accordance with voltages required for individual coils connected with rectifying bridges, individual transformers with rectifying devices for each electrode and feedback systems to maintain the current during tests. Capacitor banks were used for electrodes and magnets in impulse systems. The electromagnets in stationary MHD-accelerators were energized by electric generators. At AEDC, a project was developed to energize the MHD-accelerator from the MHD-generator, but this project was not realized yet.

The table given below summarized the main characteristics of well-known stationary MHD-accelerators of the USA, France and Russia.

Table 1. MHD-accelerators with stationary flows for wind tunnels

Organization	Langley, USA	AEDC, USA	ONERA, France	TsAGI, Russia	TsAGI, Russia Project
1	2	3	4	5	6
n	24	117	31	80	200
L , m	0,3048	0.77	0.50	0.58	1.2
F , cm ²	2.54×2.54	2.5×2.5	2.5×3.5	2.5×1.15	20×20
Q , kg/s	0.0068	0.1	0.04–0.25	0.01–0.02	~20
B , T	1.14	1.55–2.05	1.4	2.5	12
j , A/cm ²	16–20	25–60	25–30	30–60	30–40
$P_{st} \cdot 10^{-5}$, Pa	0.05	0.5	0.5	0.2	20
T_{st} , K	4400-5400	2800-3200	3000	3000	3000
$P_0 \cdot 10^{-5}$, Pa		3–6	4.5	3.0	200
T_0 , K		4000-6000	3500	3700	4700
M_b	1.6	1.6	2.0	2.0	2.0
U_{out} , m/s	6000	3800	3200	8000	6000
Gas Seed	Nitrogen 1%Cs	Nitrogen 1%NaK	Air 7%KOH (C ₂ H ₅ OH)	Air 1%NaK	Air 1%NaK
N , kW, heater	55	600		200	
N_{acc} , kW	200	1000		2000	

n – number of electrodes; L – accelerator length; F – section area; Q – gas mass flow; B – magnetic field strength; P_0 , T_0 – stagnation parameters in the conducting-gas source; M – Mach number at the accelerator entry; U – velocity; N – power.

3. NUMERICAL SIMULATION

3.1. Calculation of Gas Flows In MHD-Channel

The gas acceleration process in the MHD-channel can be considered from two standpoints: microscopic and macroscopic ones. The microscopic approach analyzes the electron and ion behaviour in mutually perpendicular E and H fields. In both cases, the accelerating force acting on the gas is produced by ions which are accelerated by external fields within the interval between collisions to transfer their momentum to neutral particles.

The flow in the Faraday-type MHD-channel with sectionalized electrodes is known to be an essentially three-dimensional one. Its reduction to a one-dimensional canonical flow derived by averaging the equations of magnetic hydrodynamics necessitates strict assumptions. Most significant among them, namely the absence of the Hall current along the channel, current non-uniformity in the interelectrode gap and, accordingly, increased resistance can be taken into account by introducing effective conductivity σ_{eff} depending on the Hall parameter and the channel sectionalization degree [28]. Voltage drop values in the boundary and electrode layers can be represented in the form of correction coefficients and volt equivalents for the anode and the cathode, respectively [27]. In this case, the equations for gas state required to close the set of magnetogasdynamic equations can be expressed both for a gas in thermodynamic equilibrium in the form of $H=H(P,T)$, $S=S(P,T)$ and for a thermodynamically non-equilibrium model in the form of a set of equations of physico-chemical kinetics. This is also the case for transfer coefficients μ , k etc.

A main problem of experimental investigations lies in the verification of all above outlined assumptions and, in particular, electrode losses and boundary layer structure.

A set of magnetic hydrodynamics equations with the above assumptions was applied at TsAGI, Russia to analyze the gas flow in the MHD-accelerator channel. As initial and boundary conditions use was made of the following experimental data: gas dynamic parameters at the MHD-channel entry P , T , U , M and distributions along the channel $P=P(x)$, $J=J(x)$, $U=U(x)$. The gas dynamic parameters at its exit obtained experimentally served for verification of the obtained solution (Fig.3). This procedure is described in detail in [29-30]. Further improvement of the one-dimensional calculation technique for MHD-channels suggests the consideration of non-equilibrium in the MHD-channel and a more detailed analysis of energy transport channels from the electric field to the kinetic flow energy assuming that the electrons accelerated in the electric field transfer their energy to vibrational degrees of freedom of air molecules and seed atoms.

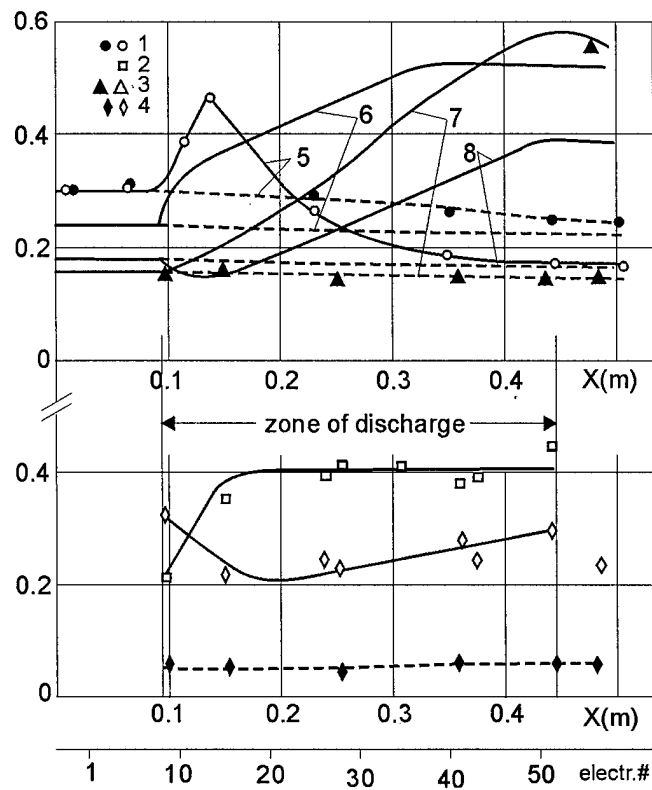

Test results:

static pressure $P \cdot 10^{-5} \text{Pa}$
 electrode voltage $V \cdot 10^{-3} \text{B}$
 current through electrodes $J \cdot 10^{-2} \text{A}$
 velocity defined by measuring the induced voltage value $U \cdot 10^{-4} \text{m/s}$

Light points show the MHD-accelerator operating, dark points show the absence of MHD-acceleration

Analytic results:

pressure $P \cdot 10^{-5} \text{Pa}$
 temperature $T \cdot 10^{-4} \text{K}$
 velocity $U \cdot 10^{-4} \text{m/s}$
 Mach number $M \cdot 10^{-1}$

Solid line = the accelerator operating, dash line = without MHD-acceleration.

Fig.3. Distribution of electric and gas-dynamic parameters along the accelerator channel

The schematic of energy transport from the electric field to internal degrees of freedom is given below.

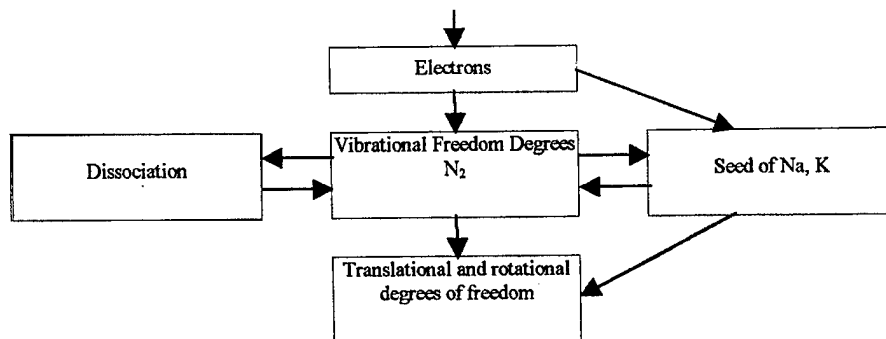

The losses of applied energy for radiation and for heat fluxes towards the electrodes and the walls are accounted for through the loss coefficient obtained experimentally. The calculations performed show that the vibrational temperature in the TsAGI MHD-channel proves to be sufficiently close to the translational one because of increasing the deactivation rate of the vibrational temperature due to O and N atoms in the flow. Comparison of calculated output parameters for the same experimental distribution of currents $J(x)$, voltages between the electrodes $U(x)$ and static pressures $P(x)$ along the MHD-channel reveals that the differences in the flow velocity and temperature calculated under assumption of thermodynamic equilibrium and without it are not very great, while the difference in the chemical gas composition is appreciable. Particular differences for the TsAGI MHD-accelerator are presented in [15]. It is significant that as the static pressure in the MHD-channel rises the degree of deviation from the equilibrium decreases. However, as the pressure rises, the heat flux q towards the electrode and the insulating walls of the MHD-channel increases proportionally [31].

The papers [32-33] contain the experimental data on convective heat flux components and the heat flux part caused by the current. The convective component is determined using heat flux values in upstream and downstream discharge zones, respectively, for the anode and cathode walls. The flow parameters (ρ , u) required for the calculations are obtained under the assumption of thermodynamic equilibrium. It is found that the convective heat flux component is satisfactorily described by the Spolding-Chee theory for a turbulent boundary layer [32], though, according to Reynolds numbers attained in the MHD-channel, the flow lies in the transitional region between laminar and turbulent flows. The boundary layer disturbances due to microarc discharges seem to cause fast boundary layer turbulization.

An intense local gas heating in the microarc at $j \geq 500 \text{ A/cm}^2$ can cause a boundary layer separation followed by formation of weak shock waves. Some regions with a spatial discharge division and with a high conduction occur in the shock waves along which the current flows. The appearance of local boundary layer separation regions leads to an increase in the aerodynamic drag of the MHD-channel. Based on the experimental data obtained at TsAGI, the friction coefficient can be taken close to $C_f \sim 5 \cdot 10^{-3}$.

It is also necessary to account for possible three-dimensional effects caused by the development of secondary flows in extended MHD-channels, the influence of electrode shunting by anode "gas" electrodes, various effects of thermodynamic non-equilibrium before we can state that the theory of MHD-accelerator is constructed.

3.2. Flow Calculation in the Secondary Nozzle

The MHD-accelerator exit is equipped with secondary nozzles. The gas expansion level in them is specified by test objectives and capabilities of the pumping system. There are almost no information about gas flows in secondary nozzles in previously mentioned publications of the USA and France. In investigations carried out at TsAGI, Russia the gas expansion level in the secondary nozzle was $F_{out}/F_{acc} \geq 100$. The investigations involved pressure distributions P_{st} along the nozzle and total pressure field behind the normal shock at its exit P_0' . Direct application of experimental data to determine gas dynamic parameters presents certain difficulties because of uncertainty in the

thermodynamic flow model. It was suggested in previous papers [29] that the flow corresponded to a frozen one with an adiabatic exponent $\gamma = 5 + 2\sum \xi_i / 3 + 2\sum \xi_i$ determined for the mixture of uniaxial and biatomic gases, where ξ_i is the mole fractions of biatomic O_2 , N_2 and NO molecules. Their values were chosen for thermodynamically equilibrium gas flows from the MHD-channel. A more detailed analysis made in [34] with due consideration of two-temperature dependence of rates of recombination and deactivation of vibrational degrees of freedom shows that the seed accelerates the deactivation of vibrational degrees of freedom of N_2 resulting in some increase in physical gas velocity, growth in the static temperature and decrease in the Mach number. The experimental Mach number at the secondary nozzle exit is $M \sim 15$ at a flow velocity of $V \sim 7800$ m/s and temperature of ~ 500 K, $P_{st} = 20-50$ Pa. Measurements of distributions of P_{st} along the nozzle and fields of P'_0 make it possible to verify the validity of the thermodynamic flow model used in the calculations. The uniformity level for fields of P'_0 at the nozzle exit depends on flow characteristics in the MHD-channel, in particular, on the Hall current. When its value is great the pressures on the cathode and anode walls differ considerably, while the flow field becomes non-uniform.

4. EXPERIMENTS WITH MHD WT

4.1. Experimental Investigation of Flow Parameters

The aerodynamic investigations require reliable gas dynamic and physico-chemical flow parameters, as well as respective means of flow visualization and measurements of forces, pressures on models and heat fluxes towards them etc. A main governing parameter is the flow velocity at the accelerator and secondary nozzle exits. There exist several methods of its measurement. A simple and low-cost way implies measuring the potential induced on one of the last non-energized electrode pair $U=ubh$, where h is the distance between the electrodes, u is the flow velocity. It is a common practice at TsAGI, Russia to use the gas dynamic method based on comparison of two measurements of P'_0 at one and the same point, i.e., first measurement when the velocity value can be derived from simple gas dynamic relationships under assumption of adiabatic and isentropic flow nature at known values of P_0 and T_0 , and the second measurement when the gas flow is subjected to some action and Joule heat is supplied to it. In this case, assuming that the profiles of pressures P'_0 are similar and gas mass flow rates in the channel with and without MHD-acceleration are constant we obtain:

$$\frac{P'_{02 \text{ with MHD}}}{P'_{01 \text{ without MHD}}} = \frac{F\rho_2 u_2^2 \left(1 - \frac{\varepsilon f_{\text{with MHD}}}{2}\right)}{F\rho_1 u_1^2 \left(1 - \frac{\varepsilon f_{\text{without MHD}}}{2}\right)} \approx \frac{u_2}{u_1}$$

Another method developed for this purpose at TsAGI is the method of measuring the velocity based on the Doppler effect. In this method, K or Na seed atom glow is excited by laser radiation with a resonance frequency at a specified flow point, a wavelength shift being measured by a Fabry-Perot interferometer. The accuracy of measuring the velocity of $\sim 6000\text{m/s}$ is $\sim 3-5\%$. Some versions of this device were also developed to obtain panoramic flow velocity values at its specified section, i.e., to obtain a velocity field in any test section part or at the nozzle exit.

The paper [35] considers the results of measurements of flow velocity fields at the channel exit by analyzing the motion of an artificial or a natural non-uniformity, but the accuracy of this method is small. The velocity value can be calculated using a certain thermodynamic flow model and applying experimental distributions of pressures, current strengths and voltages along the channel and specified parameters at its entry. Agreement of velocity values obtained by different methods used at TsAGI proves to be good.

It is impossible to determine the chemical gas composition at the nozzle exit by direct methods. Among indirect methods, the simplest method is determining $\gamma=\gamma(\xi_i)$ which is possible using static pressure distributions along a hypersonic nozzle for known pressure field of P'_0 and, accordingly, displacement thickness. The vibrational temperature level for N_2 , O_2 and NO molecules can be found by methods of emission spectroscopy with an acceptable accuracy [36]. A more detailed information about

thermodynamic flow state including level-by-level kinetics can be obtained using CARC methods, but as far as is known, this method was not applied to analyze flows in MHD-accelerators.

4.2. Application of Hypersonic MHD-Gas Acceleration Wind Tunnels to Aerodynamic Experiments

Unfortunately, the developments of hypersonic MHD-gas acceleration wind tunnels were ceased in the USA and France at the initial stage and no results of their application to solve problems of aerodynamics were published.

Visualization

At TsAGI, similar investigations were started in the 80s. They included, first of all, developments of test procedures as applied to visualization of flow patterns over space vehicle models during their atmospheric reentry and investigations of pressure and heat flux distributions on vehicle surfaces, theoretical investigations of the flow pattern in the presence of physico-chemical reactions in the boundary layer near models and at considerable "frozen" dissociation level and vibrational temperature of molecules in a free-stream flow.

The application of Na , K seeds in the flow offers radically new possibilities based on using the effects of resonant fluorescence and abnormal dispersion to visualize flows over hypersonic vehicle models. Employing laser radiation with a resonance wavelength of $\lambda=5890\text{\AA}$ in the laser knife method and optical light filters which exclude intense natural gas radiation enables the shock wave position and shape, internal flow pattern vortices, flow separation and attachment zones to be obtained (Fig.4). As a result of the application of the resonance laser radiation as a light source in the shadow device and the abnormal dispersion effect, the device sensitivity increases by a factor of 100 and more and intense natural gas radiation is eliminated [37].

Seed Effects

A detailed analysis of the seed influence on the flow over a model shows that the seed does not exert any effect on the thermodynamic gas state in the critical flow line, but it changes the position of weak shock waves at great distances from the model due to accelerated deactivation of vibrational degrees of freedom of N_2 and O_2 .

The primary seed effect consists in increased electron concentration and radiation intensity in resonance lines. Heat flux values are, however, much smaller than convective ones, therefore, they do not essentially influence the tests data.

Code Validation

Owing to well-studied techniques of determining gas dynamic flow parameters and flow visualization methods it became possible to verify calculation codes and thermodynamic models in hypersonic gas flows, as well as to conduct comparative tests in different wind tunnels to evaluate real gas effects. The experiments yielded pressure

distributions on surfaces of simple models and the data on shock wave position and shape over them. It was revealed that a gas glow region fixed visually near the model, which was taken, as a rule, as a shock wave, was considerably larger, almost 2 times than its true position obtained using the shadow method including the abnormal dispersion effect. This effect can be explained by the displacement of radiation and the diffusion of high-energy electrons from a high-temperature region ($T > 10000\text{K}$) behind the shock wave further downstream. This phenomenon was known earlier only in investigating shock waves caused by nuclear explosion and meteorites.

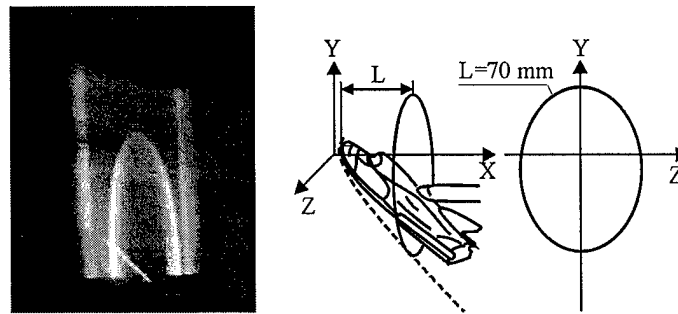

Fig.4. Normal cross section of shock wave at Bor-4 aircraft visualized by resonance fluorescence method.

The flow visualization region behind the MHD-accelerator is also of great interest for fundamental investigations of gas properties at very high temperatures and pressures ($T_0 > 10000\text{K}$, $P_0 > 10^5\text{Pa}$).

Comparison of theoretical and experimental data on pressure distributions and shock wave positions and shapes made it possible to assess the validity of some or another flow model, as well as the influence of thermodynamic medium properties.

Non-Perfect Gas Effects

How dissociation and vibrational excitation of molecules in a free-stream flow, as well as alkali seed disturb the flow pattern over models and what is the level of correspondence of wind tunnel results to full-scale data are the problems of crucial importance which affect further developments of wind tunnels with MHD-accelerators. To study these problems, gas dynamic and physico-chemical parameters of a flow over a sphere were calculated for full-scale and wind tunnel conditions assuming the equality of total stagnation enthalpy, dynamic pressures and binar similarity parameters. The calculations were carried out for a standard facility operation regime [29] which corresponded, according to the above-outlined conditions, to a flight at an altitude of 62.5km and at a velocity of 7.430m/s. The complete description of the calculation technique and the results obtained are given in [38]. It follows from the results obtained that the stand-off distance of the shock wave from the sphere in the wind tunnel is slightly greater than that in full-scale conditions due to the presence of oxygen atoms and a higher level of excitation of vibrational degree of freedom of molecules in a free-stream flow over the model. The vibrational temperature profiles in full-scale and wind tunnel conditions are similar for N_2 and O_2 molecules, while for NO the difference at the

wave front is considerable to become similar near the body surface. The excitation of vibrational degrees in the wind tunnel and in full-scale conditions is adequate.

The analysis of mass concentration profiles for O , N , NO components across the shock layer reveals that under full-scale conditions the chemical reactions proceed slower because of vibrationally dissociative interaction.

Comparison of electron densities shows that in the MHD facility the electron energy at the forward critical point exceeds full-scale values about three times, while in the vicinity of the side surface the agreement is good. The calculation data on aerodynamic heating of the body surface demonstrate a satisfactory agreement. A greater effect of catalytical surface properties for the MHD-conditions is associated with the presence of dissociated atoms and vibrationally excited molecules in a free-stream flow.

Good agreement of calculated and measured positions of the shock wave front near the body confirms rather reliably the validity of the above-considered results. It is inferred from the analysis carried out that an increased degree of dissociation and vibrational excitation of molecules in a free-stream flow changes in a certain way the flow conditions. In view of this, it is desirable to choose the facility operation conditions so that their values be minimum. Nevertheless, the facility with already attained values is suitable for testing industrial models in a hypervelocity air flow.

The flow over the Bor-4 vehicle model was investigated most comprehensively. Comparison of calculated and experimental data on shock wave position and shape near this model made it possible to assess the significance of non-equilibrium effects in flows [40]. The distributions of heat fluxes on the model surface for the space vehicle Bor-4 were in good agreement with respective flight data.

Scramjet Simulation

Of great importance in investigations carried out using this facility was the reproduction of gas dynamic parameters corresponding to the conditions in the scramjet combustion chamber in the facility test section [39,40]. The paper [40] presents the distributions of heat fluxes close to full-scale values $q=5-10\text{kW/cm}^2$ towards such scramjet combustion chamber components as, for example, fuel pylons, and evaluates the non-equilibrium influence behind the shock wave ahead of the pylons. The results obtained are compared with the Fay-Riddell theory including possible corrections for viscosity effects according to the Chang theory. It is shown that the flow behind the shock wave is in thermodynamic non-equilibrium. In the tests carried out, Mach numbers in the combustion chamber, flow velocity V , temperature T_{st} (but the pressure level was less almost 10 times) were reproduced. The total enthalpy values proved to be higher than those calculated using the gas dynamic parameters because of a considerable oxygen dissociation level.

In the 70s the problems of atmospheric vehicle reentry were solved at that stage by using much simpler and low-cost facilities: hot-shot wind tunnels, shock wind tunnels with reflected shock waves, with heavy or light pistons, classical wind tunnels with the application of various corrections for gas reality, viscosity and compressibility effects and by employing computational fluid dynamics methods to much more extent. Early in the

90s, the interest to MHD-accelerators was rekindled because of the development of transatmospheric vehicles (TAV vehicles). If tests on models of a smaller scale (1:10–25) during a short time period of $\tau \sim 10s^{-2}$ are sufficient for investigating airframes, input engine diffusers and integrated engine nozzle-airframe configuration, i.e., the available test facilities can be used, the optimization of the TAV engine necessitates full-scale tests during a rather long time. There are no adequate aerodynamic test rigs for this purpose and hypersonic MHD-gas acceleration wind tunnels prove to be just the only facilities essentially suitable for similar investigations [41-42]. But up to now a number of fundamental problems concerning the influence of seeds and deviations of the chemical compositions of free-stream gases from natural air on physico-chemical processes and on oxygen burning remain unsolved. It follows from the calculations that the mole fraction of "O" atoms (radicals) in the free-stream flow more than 10% changes considerably the hydrogen burning process, induction time, equilibrium fraction of water vapors, as well as parameters P , ρ , T along the combustion chamber. Therefore, this facility is of little use for testing scramjets because an acceptable deviation must be less than 5%. The presence of NO in the flow to the extent of $\sim 5\%$ and of Na , K atoms in amounts of 1% does not essentially influence the burning process.

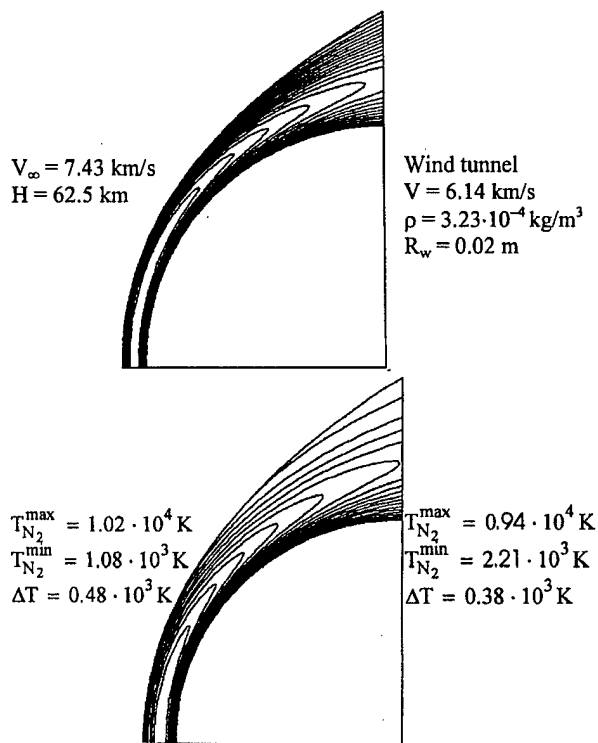

Fig.5. T_{N_2} isolines in the shock layer

Operational Map

The paper [42] considers the parametric calculations of MHD-accelerator under the assumption of a thermodynamical equilibrium in the channel to find optimal parameters sufficient to solve the scramjet parameters. The calculations were performed at constant

stagnation parameters $P_0=2 \cdot 10^7 \text{ Pa}$, $T_0=4700 \text{ K}$ and gas mass flow rate of $\sim 20 \text{ kg/s}$, and variable magnetic induction S , current density j , Mach number at the channel entry and channel wall angles. The secondary nozzle parameters were chosen so that $P_{st}=5 \cdot 10^4 \text{ Pa}$, $T_{st}=2642 \text{ K}$, $U=6008 \text{ m/c}$ were attained at its exit, i.e., the values at the chamber entry at $M=20$. According to this paper, it is quite possible to obtain flow parameters close to required ones using the MHD-accelerator at $B=12-16 \text{ T}$. In the paper [43], the MHD-accelerator was calculated at the same initial parameters based on the TsAGI data for a thermodynamically non-equilibrium gas and with the consideration of a possible increase in the electron temperature as compared to the gas temperature. According to the data obtained, the non-equilibrium phenomenon is favorable in this case for flow parameters and the dissociation level at the channel exit decreases almost 2 times. Comparison of parameters realized in the scramjet combustion chamber and at the secondary nozzle exit reveals that the above stated problem can be solved at Mach flight numbers $M=15-20$. When this flow expands in the secondary nozzle up to static temperatures corresponding to atmospheric conditions it is possible to attain in the test section full-scale Mach numbers ($M=20-25$), full-scale flight velocities at pressures corresponding to flight altitudes of $H=65-80 \text{ km}$. The resulting flow differs slightly from the real one by the presence of NO molecules (5-6%) and O atoms (2-2.5%), but such percentage does not influence the flow over the vehicle (Fig.6).

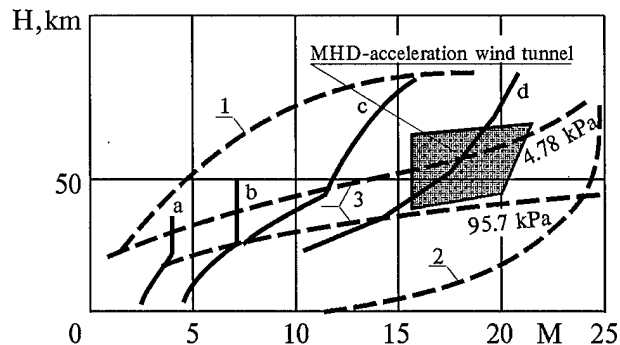

Fig.6. Regions of flight trajectory modelling in wind tunnels of different classes. 1. Missile start trajectory, 2. Atmospheric entry trajectory for ballistic heads, 3. Flight corridor for orbiter with scramjet, a) Continuous wind tunnel, b) Intermittent wind tunnel, c) Arc heating wind tunnel, d) Hot-shot wind tunnel

Future Facility

Comparison of this MHD-channel with that used at TsAGI shows that the power applied to the new channel should be increased 1000 times, the pressure 100 times, the magnetic induction 5 times and the channel length 4-5 times, the relative MHD-channel length (number of gauges) decreases by a factor of 3-4. The construction of a similar MHD-channel poses a number of essentially new problems, the main of them is the development of a serviceable structure designed for convective heat fluxes towards its walls of $q=20-60 \text{ MW/m}^2$, to which should be added heat fluxes due to the electrode phenomena $q_e \sim 10-20 \text{ MW/m}^2$, thus providing a specified velocity field uniformity level at the nozzle exit etc. The MHD-channel structure should be cooled to operate within $\tau \geq 10-60 \text{ s}$. It is unlikely to

develop a similar structure because the insulator surface temperature during the start attains the melting temperature for $\tau \sim 10^{-3}$ s, while the copper electrode surface temperature for $\tau \sim 5 \cdot 10^{-1}$ s. Thin insulating film coatings deposited on the copper are also not effective. The only way is to create a gas screen from a light gas (helium) enabling the heat flux to the walls to be decreased considerably. There are, however, no data on the MHD-operation with a gas screen. The serviceability of the electrode-insulator joint can be ensured if some means of controlling the microarc motion on the electrode surface are developed to prevent microarc concentrations at the electrode end. The uniformity of velocity fields and of chemical air composition at the secondary nozzle exit dictates the elimination of the influence of the Hall current, current stubs due to microarcs and respective three-dimensional effects. The development of remaining structural components of a hypersonic wind tunnel (arc heater, seed supply system, primary and secondary nozzles, test section, super- and subsonic diffusers, cooler and exhaust system) does not presents considerable difficulties except for the magnetic system designed for $B=12$ T. Thus, the development of a hypersonic MHD-acceleration wind tunnel capable of reproducing correctly the scramjet combustion chamber entry conditions and flight conditions at 65–75km is an extremely complicated problem to be comparable with the problem of developing the scramjet itself. For this purpose, it is necessary to attract specialists of a very wide spectrum and to apply the achievements which have gained in high-temperature magnetic gas dynamics and hydrodynamics for the latest 30 years.

CONCLUSION

1. Hypersonic MHD-gas acceleration wind tunnels developed by the present time are used successfully to solve practical problems of hypersonic aerodynamics, to verify computational codes and calculated thermodynamic medium models for non-equilibrium gas flows.
2. In principle, it is quite possible to construct a MHD-accelerator to test scramjets for TAV vehicles. This problem is comparable with the development of the scramjet itself. It will demand much time and considerable funding.

REFERENCES

1. E.P.Gurjanov and P.T.Harsha, AJAX: New Directions in Hypersonic Technology, AIAA Paper 96-4609.
2. V.A.Bityurin, V.A.Zeigarnik, A.L.Kuranov, On a Perspective of MHD Technology in Aerospace Applications. // AIAA Paper 96-2355, 27th AIAA Plasmadynamics and Lasers Conference, New Orleans, 1996.
3. V.A. Bityurin and J.T. Lineberry, V.G. Potebnia, V.I. Alferov, A.L. Kuranov and E.G. Sheikin, Assessment of Hypersonic MHD Concepts // AIAA 97-2393, 28th Plasmadynamics and Lasers Conference, June 23-25, 1997, Atlanta, GA
4. Brichkin D.I., Kuranov A.L. and Sheikin E.G. MHD-Technology for Scramjet Control. // AIAA Paper 98-1642, 8th International Space Planes and Hypersonic Systems and Technologies Conference, April 27-30, 1998, Norfolk, VA.
5. V.A.Bityurin and J.T.Lineberry, Overview of MHD Applications (MHD Assisted Hypersonic Flight), In: Plasma/ Electromagnetic Advanced Propulsion Workshop, 10-11 Dec., 1997, UTSI, TN.
6. J.Cole, J.T.Lineberry, V.A.Bityurin. MHD Augmented Hypersonic Propulsion Systems // Workshop "Perspectives of MHD and Plasma technologies in Aerospace Applications", March, 24-25, IVT RAS, Moscow, 1999, p.22-30
7. V.A.Bityurin, J.T.Lineberry, R.J.Lichford, J.W.Cole. Thermodynamic Analysis of the AJAX Propulsion Concept (invited). // AIAA 2000-0445, 38th AIAA Aerospace Sciences Meeting, 10-13 January 2000/Reno, Nevada.
8. Grabowsky W.R., Durran D.A., Mirels H., Performance of a 500kJ MHD Wind Tunnel, AIAA Paper 68-370, 1968
9. Harris C.J., Marston C.H. Rogers D.A., Malli W.R., A High Density Shock Tunnel Augmented by a Faraday Accelerator, Fourth Hypervelocity Techniques Symposium, Arnold Air Force Station, Nov. 1965
10. Leonard R.L. Rose R.H. Design and Operation of a Large Pulsed JxB Accelerator, Sixth Symposium on Engineering Aspects of Magnetohydrodynamics, Pittsburg Pa, 1965
11. J.Michard (ONERA) et J.Desimone (CGE), Experimentation d'unaccelerateteur de plasma a champs crouses, Entropie N29 (1969).
12. Tempelmeyer K.E., Windmuller A.K., Rittenhouse L.E., Development of Steady-Flow jxB Accelerator for Wind Tunnel Application, Arc Heaters and MHD Accelerators for Aerodynamic Purposes. Supplement to AGARDograph N84, August, 1964
13. Alforyov V.I., Vutkovskaya O.M. Ustinov Yu.S. and Shcherbakov G.I., Arc Heater with an Arc Rotated by a Magnetic Field, TVT, vol.9, N2, p.395-400, 1971 (in Russian)
14. Carter A.F., Wood G.P., McFarland D.R., Weaver W.R., Research on Linear Direct-Current Plasma Accelerator, AIAA Journal, vol.3, p.1040 (1965), AIAA Paper 66-180, 1966
15. Alforyov V.I., Vitkovskaya O.M., Rudakova A.P. and Shcherbakov G.I., Investigation of the Aerodynamic Facility with Magnetogasdynamic Gas Acceleration, TVT, vol. 17, N1, p.163-171, 1979 (in Russian)

16. Nelson G.L. and Simmons G., Augmentation of Hypersonic Propulsion Test Facilities Using MHD, AIAA Paper N 95-1973
17. Harris C.J., Marston C.H., and Warren W.R.Jr., MHD Augmented Shock Tunnel Experiments with Unseeded High Density Air Flows, AIAA Journal, vol.13, N2, p.229-231, 1975
18. Shair F.H. and Sherman A., Electron Beam Preionization in MHD Generator, Sixth SEAM, Pa, April 21-22, 1965
19. Park S.K., The thermodynamic Properties of Seed Nitrogen, Fifth Intercenter and Contractors Conference on Plasma Physics, Part II, NASA Langley Research Center, 1966
20. Rose R., Arc Boundary Layer Behavior, 8th International Conference on MHD-Power Generation, t.1, p.251, Moscow, 1983
21. Baranov V.Yu., Vvedenov A.A., Velikhov Ye.P., Investigation of Plasma Flow Stagnation in a Magnetic Field, Dokl. Akademii Nauk, SSSR, vol.229, N6, 1338-1340, 1974 (in Russian)
22. Rittenhouse L.E., and Whorrie J.M., A physical Model of the Electrode Discharge with Cold Electrodes in Supersonic Jet Seeded Plasma, Sixth Symposium on Engineering Aspects of Magnetohydrodynamics, Pittsburgh, Pa, USA, April 21-22, 1965
23. Alforyov V.I., Witkovskaya O.N., Labaskin A.P., Rudakova A.P., and Shcherbakov G.I., Investigation of Electrical Discharge in MHDChannel, VIII International Conference on MHD Electrical Power Generation, Moscow, vol. VI, 1983
24. Labaskin A.P., Shcherbakov G.I., Experimental Investigation of Current Sheet in MHD-Accelerator Electrode Wall Region, XI International Conference on Magnetohydrodynamic Electric Power Generation, China, 1992
25. Alforyov V.I., Bushmin A.S., Electric Discharge in a Supersonic Air Flow, Zhurnal teoreticheskoi i eksperimentalnoy fiziki (ZhETF), vol.44, issue 6, p.1775, 1963 (in Russian)
26. Windmuller A.K., and Rittenhouse, Status Report on the Design and Test Experience of Steady Flow $j \times B$ Accelerator for Wind Tunnel Application, Proceedings of Fifth Symposium on Engineering Aspects of Magnetohydrodynamics, 1964
27. Alforyov V.I., Vitkovskaya O.N., Rudakova A.P., Shcherbakov G.I., Electrodynamic Characteristics of MHD-Accelerator, TVT, N2 1979 (in Russian)
28. Selinski N., Fischer F.W., Effect of Electrode Size in MHD Generators with Segmented Electrodes, AJAA Journal, vol.4, p.421-428 (1968)
29. Alforyov V.I., Witkovskaya O.N., Rudakova A.P., Rukavets V.P., Shcherbakov G.I., Gas-Dynamic Wind Tunnel with MHD-Gas Acceleration, 10th International Conference on Magnetohydrodynamic Power Electric Generation, Tirchi, India, vol.1, VII, p.31-34, 1989
30. Zdukevich M.D., Sevastyanov P.M., Standard Program to Calculate Thermodynamic Air Properties and Equilibrium Conduction with Alkali Seeds, Trudy TsAGI, NN1009, 1010, 1966 (in Russian)
31. Alforyov V.I., A Report on the Status of MHD Hypersonic Ground Test Technology in Russia, AJAA Paper 93-3193 (1993).
32. Alforyov V.I., Vitkovskaya O.N., Panfilova O.V., Rudakova A.P., Sukhobokov A.D., Shcherbakov G.I. Experimental Investigation of Temperature Fields of Heat

- Fluxes in the MHD-Accelerator Electrode Walls, TVT, vol.18, N1, p.181-198, 1980
(in Russian)
33. Labaskin A.P., The Experimental Investigation of Temperature Fields and Heat Fluxes over Electrode Walls of High Enthalpy MHD-channel, X International Conference on Magnetohydrodynamic Electric Power Generation, Tirchi India, 1989.
 34. Alforyov V.I., Dmitirev L.M., Yegorov B.N., and Markachev Yu.E., Investigation of Physico-Chemical Processes in Hypervelocity MHD-Gas Acceleration Wind Tunnels, 33rd SEAM Proceedings Tullahoma, 1995
 35. Weaver W.R., Carter A.F., McFarland D.R., Wood G.R., Results of Diagnostics of the Flow from the Langley Linear Plasma, Fifth Intercenter and Contractors Conference on Plasma Physics, Part II, Washington DC May (1966).
 36. Alforyov V.I., Bushmin A.S., Dmitriev L.M. Methods of Experimental Investigations of Thermally Nonequilibrium Flows // Trudy TsAGI, issue 1847, 1977 (in Russian)
 37. Alforyov V.I., Shcherbakov G.I., Rudakova A.P., Yegorov I.V., Yegorov B.V., Markachev Yu.Ye., Morozov A.N., Dmitriev L.M., Bushmin A.S., Orlov A.A., and Skirda V.N., Investigation of Relaxation Processes in Flows about Models in Hypersonic Wind tunnels of Different Types // 16th, ISIA SF, 95 International Congress on Instrumentation in Aerospace Simulation Facilities, USA Wright Laboratory, Ohio, 1995, p. 48-148-11, 1995
 38. Alforyov V.I., Yegorov I.V., Hypersonic Flow in MHD-Acceleration Facility and in Real Gas. // PMTF No.4, 1997 (in Russian)
 39. Alforyov V.I. On the Problem of Creating Flow Conditions in Scramjet Combustion Chamber in Wind Tunnels, AIAA Paper 93-1843
 40. Alforyov V.I., Yegorov I.V., Shcherbakov G.I., On the Application of MHD Gas Acceleration Wind Tunnels to Investigate Hypersonic Gas Flows over Bodies, SEAM 33 Tullahoma, TN, p.V 2-1, t.2-6, 1995
 41. Boudreau A., Smith V., and Daniel D., Development and Testing of Scramjet Propulsion Systems, AIAA Paper 93-5121
 42. M.J. Christiansen, Schmidt H.J. Chapman J.N., Further Analysis of MHD Acceleration for Hypersonic Wind Tunnel, 33rd SEAM Proceedings, Tullahoma, TN p.v5-1, v.5-8
 43. Background and Prediction of Current Full Scale Reproduction in Wind Tunnels as Concerns Gas Dynamic Parameters of Hypervelocity Atmospheric Flight and Scramjet Combustion Chamber Condition (17s ICASF 1997)