

AR

5536

RECORD
COPY

JPRS: 5536

12 September 1960

SELECTED ECONOMIC TRANSLATIONS
ON EASTERN EUROPE

MAIN FILE

(218th in the series)

REPRODUCED FROM BEST AVAILABLE COPY

DISTRIBUTION STATEMENT A
Approved for Public Release
Distribution Unlimited

20000714 020

**Reproduced From
Best Available Copy**

Photocopies of this report may be purchased from:

PHOTODUPLICATION SERVICE
LIBRARY OF CONGRESS
WASHINGTON 25, D.C.

U.S. JOINT PUBLICATIONS RESEARCH SERVICE
205 EAST 42nd STREET, SUITE 300
NEW YORK 17, N. Y.

DTIC QUALITY INSPECTED 4

JPRS: 5536

CSO: 2000-N/218

SELECTED ECONOMIC TRANSLATIONS
ON EASTERN EUROPE

INTRODUCTION

This is a serial publication containing selected translations on all categories of economic subjects and on geography. This report contains translations on subjects listed in the table of contents below. The translations are arranged alphabetically by country.

TABLE OF CONTENTS

	Page
BULGARIA	
Development of Cattle Raising.....	1
Instruction No Zh 9 on the Purchase of Calves and Buffalo Calves for Slaughter, by the Ministry of Agriculture and Forests.....	6
Impoverishment of Ore Mines and Possibilities for Reducing it.....	10
CZECHOSLOVAKIA	
Retail Price Reduction Announced.....	24
Radio-Range Communications on Centimeter Waves.....	35
Wood Consumption and Its Utilization in the Individual Consumer Sectors in Czechoslovakia.....	46
Upright Drill of the Type VV-11-R-2.....	53
Claw-Type Loader.....	56
EAST GERMANY	
Conference of Electrical Engineers.....	58
The RVG 934 Radio Relay with Pulse-Phase Modulation.....	65
New Products of the VVB Communications and Measuring Engineering.....	83
The Role of Standardization in the Fulfillment of the Chemical Program of East Germany.....	96
Standardization in the Use of Printed Circuits.....	109
Economic Briefs.....	123

BULGARIA

Development of Cattle Raising

[The following is a translation of an unsigned article in Zhivotnovudstvo, Vol XIV, No 3, March 1960, Sofia, pages 1-3; CSO: 4127-N]

The number of horned livestock has considerably decreased during the last 10 to 12 years; cattle alone decreased from 1,783,410 heads at the end of 1948 to 1,283,914 on 1 January 1960. During this period, the number of cows has decreased by 193,689. This continuous decrease has placed difficulties in the way of supplying the workers with meat. In 1959 beef and buffalo meat comprised 27.75 percent of the total production, which is entirely insufficient. In the case of Bulgarian climatic conditions and eating habits, beef and buffalo meat should constitute not less than 35 percent of the meat consumption. The constant improvement being made in the material well-being of the workers also requires a greater production of beef and veal, which, in contrast to pork, is consumed readily by the entire population.

The measures which have been adopted so far in the field of cattle raising have been reflected chiefly in the improvement of the fertility of the cattle herds and in the increase of their milk yields. The average milk yield from cows has increased during the last 20 years for the country as a whole by about 2.80 times, and in the TKZS, for the period since 1952, by 3.75 times.

The annual production of beef and buffalo meat did not decrease only because the number of animals slaughtered for meat was always larger than the number of calves born during the corresponding year.

In order to put a stop to the haphazard slaughtering of horned cattle, the Council of Ministers passed a decree in favor of a further development of cattle raising.

The decree (postanovlenie) stipulates the limitation of the slaughtering of all cows, female buffalo, heifers, and buffalo heifers, calves and buffalo calves. These animals may be slaughtered only in the case of proven infertility and at a

stipulated age. These measures are designed to protect female stud animals; this will bring about in the next few years an increased reproduction of the cattle and buffalo herds. For this purpose it is intended to have all female studs branded and indexed.

Considerable attention is being devoted to the purchasing of cattle offered for sale. As a result of the incorrect tendencies displayed during the past year in regard to animals earmarked for the private use of cooperative farmers, the number of cows and buffalos in their possession has considerably decreased--from 365,811 to 271,556. This decrease has not stopped even now, because the cooperative farmers do not have enough fodder. An important role in the protection of the cattle and buffalo herds from arbitrary slaughtering can and must be played by the "Zhivsnab" DTP ["Animal Supply" State Trading Enterprise]. The enterprise must at this time develop considerable activity in order to track down all animals for sale and offer them to cooperative and state farms that need livestock for breeding, [promote] barn and pasture fattening, and create meat production farms. With good organization the sale to meat centers of animals suitable for breeding and pregnant cows and buffalos can be avoided.

The decree obligates the Bulgarian Investment Bank to make interest-free loans available to the TKZS's for the purchase of horned livestock for breeding, with 30 percent of the loan to be used for the purchase of young animals: heifers, buffalo heifers, female calves, and buffalo calves which are now being destroyed; this is designed to save them for the national economy. Along with the branding and indexing of the female stud animals, the obshtina people's councils must register calves and buffalo calves born outside of the TKZS and DZS so that they may be safeguarded.

Large reserves in the increase of meat production from horned livestock are represented by cow farms designed to produce meat by-products. In this respect the decree empowered the okrug people's councils to determine, depending on the conditions of the region, in which TKZS and DZS these farms can be organized and how many cows they should contain. In mountainous and semi-mountainous regions, having sufficient pasture and meadow land, the farms for the production of meat by-products are a well-planned enterprise. All cows and buffalos with small milk yields, instead of being supplied to the "Meat Industry" State Supply Enterprise as heretofore, must now be used for the establishment of cow farms

for the production of meat by-products. Only those cows and buffalos over 15 to 16 years of age, and those whose infertility has been proved, must be separated into a group earmarked for fattening.

In the past, 85 percent of the animals for slaughter were not fattened before slaughtering. As a result, the consumer received low-quality beef and buffalo meat and the national economy lost annually 20,000 to 30,000 tons of meat of the horned livestock type. The recent increase in the price of beef and buffalo meat from 5 to 6 leva [per kilogram?] and of veal and buffalo veal from 6 to 8 leva, has created a considerable material incentive for the producers to subject all animals earmarked for slaughter to a pre-slaughter fattening process. In the future, the main source of meat from cattle raising will be male calves. For this reason, the decree determines the price of 8 leva [per kilogram?] as the purchasing price for the Kula cattle, the Sofia brown cattle, "simental" cattle, "montafon" cattle, the black-grey cattle and their hybrids, with a weight on the hoof of over 320 kilograms; for the red cattle and its hybrids, with a weight of 280 kilograms; for the Iskur cattle, with a weight of 280 kilograms; for the grey local cattle, with a weight of 220 kilograms; for the Rhodope cattle and its hybrids, with a weight of 120 kilograms; and for buffalo calves, with a weight of 220 kilograms.

Bulgarian and foreign researchers have found that the economic maturity of calves earmarked for slaughter takes place at an age of about 18 months. At this age, given comparatively good food and care, the calves of Bulgarian cattle varieties reach the established weight on the hoof.

Considerable possibilities of increasing the herds of horned livestock, mostly of cows and female buffalos, exist in the case of many cooperative farmers. On 1 January 1950, only 22.6 percent of cooperative farmers had one cow or female buffalo. This percentage is extremely unsatisfactory. Depending on the type of agriculture, the soil and climatic conditions in a given region, the amount of pastures and meadows, and the past traditions of the population in raising one or another kind of productive animals, at least 500,000 households can keep a cow or a female buffalo.

In this manner, the number of horned livestock, instead of decreasing, will increase, which is in the interest of the cooperative farmers and the entire national economy. In order

to create a greater material incentive for the cooperative farmers to raise more horned livestock, the decree stipulates that TKZS, on the basis of a decision reached by the general meeting, and in cases where conditions exist for this purpose, sow--at the expense of the cooperative farmers--one to two decares of grass forage plants and one to two decares of grain forage plants on land set aside for private use. The forage thus obtained will be used for livestock owned privately by them. In addition, the TKZS are obligated to turn poorly producing land into "artificial" pastures, instead of sowing or planting them to bread grains or industrial crops. This land may be sown in esparto grass and other suitable grass varieties or their mixtures. Thus, sufficient fodder will be obtained for the livestock. By means of these and other supplementary measures, the application of which is being planned this year to increase fodder production, it will become possible to considerably increase the number of horned livestock in the TKZS, DZS, and cooperative farm households.

In order to create a Bulgarian meat cattle variety, plans are being made to import this year cows and bulls of noted meat breeds, such as Hereford, "sharole," and others. Many Bulgarian experts are of the opinion that this is not a correct policy; they reason that, given correct feeding, care, and use of native Bulgarian breeds, these will supply meat not only in sufficient quantities but also of good quality. So far this has not been proved correct at all. But if we examine the question from the point of view that the purchasing power and demands of the workers in regard to the quality of the meat on sale will increase even more, it becomes clear that the present breeds will not meet these requirements.

In connection with the import of the above-mentioned animals, tentative plans are being made to carry out certain experiments in animal husbandry scientific research institutes. Depending on the results obtained, attempts will be made to create a Bulgarian meat breed by way of large-scale mass cross-breeding.

The sugar and alcohol plants, breweries, and other plants and shops make available valuable fodder waste products which can be successfully utilized for the feeding of a large number of horned livestock. The decree therefore charges the Ministry of Agriculture and Forestry with the responsibility to establish, in cooperation with the okrug people's councils, inter-cooperative farm enterprises for the raising of horned livestock. Thanks to these enterprises, the production cost

of meat will considerably decrease, since the waste products, which have a large water content, will be used as fodder for animals, without being transported over great distances.

The TKZS administrative councils and agricultural experts must start working on the fulfillment of the Ministerial Council's decree on the increase of the number of horned livestock and the production of meat.

BULGARIA

Instruction No Zh 9 on the Purchase of Calves and Buffalo Calves for Slaughter, by the Ministry of Internal Trade and Ministry of Agriculture and Forests

[The following is a translation from Izvestiya, Vol XI, No 13, 9 February 1960, Sofia, page 2; CSO: 4139-N]

In order to ensure the regular enforcement of Decision No 18 of the Council of Ministers, dated 18 January 1960, on the development of cattle-rearing by state meat combines:

1. Calves and buffalo calves shall be purchased from TKZS's [Cooperative Labor Farms], DZS's [State Farms], state, cooperative, and obshtina farms, cooperative members and other private producers and paid by state meat combines as of 18 January 1960, according to breeds and live weight, as follows:

<u>Specifications</u>	5 Leva per Kilogram of Live Weight for Calves and Buffalo Calves with Live Weight Up to	8 Leva per Kilogram for Calves and Buffalo Calves with Live Weight Above
Kula, Sofia, brown "Siementhal," black spotted Montafon, and the cross-breeds	320	320
Red cattle and their cross-breeds	280	280
Iskur cattle	260	260
Local grey cattle	220	220
Rhodope cattle and their cross-breeds	120	120
Buffalo calves	220	220

The price of calves and buffalo calves will be 8 leva per kilogram of live weight when the above fixed kilograms in live weight for the breed are established according to the actually measured purchase weight, without deduction for the stomach-bowels content, which, under normal nutrition, constitutes a 3-percent loss.

Payment for calves and buffalo calves purchased from producers shall be made after deduction of the stomach-bowels content fixed by point 12 of the ordinance on the purchase of animals for slaughter issued by the Ministry of Trade and the Ministry of Agriculture and Forests, published in the Izvestiya No 56 of 14 July 1959.

For instance, when purchasing calves and buffalo calves from producers at 8 leva per live weight kilograms of various breeds, one shall pay for calves and buffalo calves, sold at a minimum actually measured purchase live weight of, for example, 321, 281, 261, 221, or 121 kilograms, the producers are paid 8 leva per kilogram of live weight at actually measured purchase weight of the calf less deduction of stomach-bowels content of 3 percent--i.e., in the given examples 311.37, 272.57, 253.17, 214.37, and 117.37 kilograms of live weight.

As the live weight of calves and buffalo calves purchased from producers at 8 leva per kilogram of live weight is determined at normal nutrition of 3 percent, the example indicates the minimum purchase weight payment for different breeds, above which state meat combines must pay producers of purchased calves and buffalo calves 8 leva per kilogram of live weight.

2. The breed of calves purchased for slaughter, payable at 8 leva per kilogram of live weight is determined by a stud certificate of breed origin according to the established sample.

Stud certificates of calves for slaughter purchased from TKZS's, cooperative members, and other private producers are delivered by the official zootechnician at the TKZS and are certified by the signature and stamp of the chairman of the respective obshtina people's council.

Stud certificates of calves for slaughter purchased from DZS's and other state cooperative and obshtina farms are delivered by the respective zootechnician at these farms and

are certified by the signature and stamp of the farm director or manager.

A copy of the delivered stud certificate is kept at the obshtina people's council which certified it, or in whose area the farm was situated.

Any official who allows the issue of a false stud certificate relating to calves for slaughter in order to influence the purchasing agency or the producers is liable to legal and material responsibility for the infraction committed.

In the delivery and purchase-payment receipts concerning calves for slaughter payable at 8 leva per kilogram of live weight, the earmark and the breed of the calf should be entered, and a copy of the stud certificate issued should be attached. A second copy of the stud certificate is attached to the shipment receipt of those calves which, after purchase, are destined for slaughter in other meat combines, where it is attached to the delivery statement.

3. On arrival of the purchased calves to the slaughter house of the local meat combine or other meat combine, they are accepted according to breed indicated on the accompanying documents.

If at the slaughter house a misdesignation of breed is established, the nonconformity between the calves delivered for slaughter and the accompanying documents is established by a report drawn up by a commission composed of the officiating veterinary doctor of the State Supreme Sanitary Control the DVSN [not identified], and the technologist of the meat combine.

On the basis of the evidence relating to the nonconformity:

- a) the meat combine purchasers locate the official who delivered the stud certificate of calves for slaughter, in conformity to point 2, item V of the present instruction; and
- b) the receiving meat combine presents a claim to the meat combine that shipped the calves for slaughter.

4. In accordance with point 5 of Ordinance 52 of the Central Committee of the Bulgarian Communist Party and the Council of Ministers, of 26 March 1958, it is forbidden to slaughter calves and buffalo calves in approved meat producing establishments--state and obshtina slaughter houses--below the following live weights (in kilograms):

Rhodope cattle and buffalo calves	80
Iskur cattle and other local breeds	160
Red-brown Siementhal and other improved breeds	190

Established minimum live weights for the slaughter of calves and buffalo calves are understood to be:

On purchase--actual measured purchase live weight without deduction of food and transport losses.

On arrival from state fattening farms of meat combines--the live weight measured on acceptance at the slaughter house, after deduction of food and transport losses.

5. State meat combines and cooperative labor farms may purchase calves and buffalo calves from cooperative members and private farmers for fattening purposes under the minimum slaughter weight fixed in point 4 of the present instruction.

R. Hristozov, Minister of
Internal Trade
D. Yurukov, Deputy Minister
of Agriculture and
Forests

BULGARIA

Impoverishment of Ore Mines and Possibilities for Reducing It

[The following is a translation of an article by Y. Kunen and P. Baltaolzhiev, published in Minno Delo i Metalurgiya, Vol XV, No 1, January 1960, Sofia, pages 16-22; CSO: 4164-N]

The program of the Bulgarian Communist Party for completing the Third Five-Year Plan in a shorter period of time creates particularly important problems for the mining industry--to increase production and greatly decrease prices of ores and concentrate.

Parallel to the adoption of advanced techniques in mines and beneficiation plants, the introduction of more efficient methods of work, decreased costs for ore transport to the beneficiation plants, improvement of production methods, etc., an important factor for the decrease of ore prices and concentrates is the increase of the metal content in the ores by decreasing the percentage of impoverishing rocks--i.e., gangue.

From reports submitted, it appears that for 1958 the impoverishment in mines amounts to 6 to 34 percent--averaging 14.88 percent, and for the first half of 1959, 5 to 32 percent--averaging 14.16 percent. Investigations made by the Conservation of the Earth (Okhrana na zemnite nedra) agency indicate that the impoverishment stated in mine reports is considerably lower than the above figures. In some of the investigated mines, the difference reaches 10 percent or more.

For both 1958 and the first half of 1959, the actual impoverishment in most mines is 2 to 3 percent or more greater than that approved.

The tables show that a one percent increase of gangue in ores leads to annual losses of 3 to 4 million leva. Taking into account the selling price of concentrates which would have been produced and sold, the fact that one percent gangue carries away 350 tons of metal annually in tailings, together with the additional wasted load on factories, the actual annual loss increases to 809 million leva.

Table 1

Impoverishment for 1958

State Mining Enterprises [DMP]	Produced Ore Tons	Impoverishing Rocks in Ore Per- cent	Tons	Direct Expenses for Producing, Transport and Flotation of Im- poverishing Rocks	
				Leva per Ton	Total
Gorubso Ore Mining Administrations:					
I	557,200	13.1	72,993	143	10,437,999
II	348,800	12.5	43,600	140	6,104,000
III	328,300	15.7	51,543	130	6,700,590
IV	411,600	8.4	34,574	120	4,148,880
Rhodope Severni branch	78,900	13.8	8,882	143	1,270,126
Ustrem	42,900	13.2	5,663	124	702,212
Madyarovo	44,200	17.2	7,602	185	1,406,370
G. Dimitrov	78,200	13.7	10,713	117	1,253,421
Chiprovtsi	158,900	9.9	15,731	67	1,053,977
Vatiya Etropole mine	19,600	26.0	5,096	130	662,480
DMP Burgaski Copper Mines:					
Rosen branch	364,100	19.5	70,999	68	4,827,932
Vu'rli Bryag branch	132,600	28.2	37,393	95	3,552,335
Panagiurski mini:					
Radka mine	86,000	13.7	11,782	115	1,354,930
Elshitza, copper mine	49,400	17.6	8,694	115	999,810
Zapadni mini:					
Zlata, gold mine	38,300	34.0	13,022	70	911,510
Vasil Kolarov	242,400	22.7	55,025	110	6,052,750
Zhelezni rudi	77,200	5.8	4,497	106	476,682
Pobeida	17,400	-	-	-	-
Total	3,076,000	14.9	457,809	113.40	51,916,034
Annual economy from a one- percent decrease in impoverish- ment					
		1.0	30,767	113.40	3,488,978

Table 2

Impoverishment During the First Half of 1959

State Mining Enterprises	Produced Ores Tons	Impoverishing Rocks in Ore		Direct Expenses for Producing, Transport and Flotation of Im- poverishing Rocks	
		Per- cent	Tons	Leva per Ton	Total
Gorubso Ore Mining Administrations:					
I	284,739	12.6	35,877	143	5,130,411
II	158,163	12.9	20,403	140	2,856,420
III	128,301	13.6	17,449	130	2,268,370
IV	226,002	9.4	21,244	120	2,549,280
Severni Rhodope branch	103,368	17.2	17,779	143	2,542,397
Ustrem	30,000	13.2	3,960	124	491,040
Madzhapovo	26,763	13.2	3,532	185	653,420
G. Dimitrov	49,805	8.2	4,079	117	477,243
Chiprovtsi	94,974	11.6	11,017	67	738,139
Vatiya:					
Etropole, lead- zinc ore mine	7,993	19.7	1,575	130	204,750
Chelopech, copper ore mine	7,405	14.7	1,088	120	130,560
Burgas copper mines:					
Rosen branch	209,800	17.3	36,295	68	2,468,060
Vu'rli Bpyag branch	90,000	32.0	28,800	95	2,763,000
Zapadni mini:					
Zlata gold mine	20,258	21.2	4,295	70	300,650
Panagyurski mini:					
Radka, copper ore mine	43,140	12.5	5,392	115	620,080
Elshitza, copper ore mine	49,891	12.6	6,286	115	722,890
Vasil Kolarov	137,200	17.1	23,461	110	2,580,710
Zhelezni rudi	50,349	4.3	2,150	106	227,900
Pobeida	9,350	-	-	-	-
Total	1,727,501	14.2	244,682	113.20	27,689,320
Semi-annual saving from decreasing im- poverishment one %					
	-	1.0	17,280	113.20	1,956,096

Investigations by the Conservation of the Earth agency showed that the reported impoverishment and that given in the tables is actually 2 to 3 percent or more lower than the actual figures. This indicates the enormous possibility hidden in lower impoverishment for decreasing ore and concentrate prices.

Up to the beginning of 1958, no important consideration was given by our mines to the decrease of impoverishment. The major aim was to produce more ore, without considering the metal content--i.e., without trying to increase it by decreasing the percentage of impoverishment.

After the Conservation of the Earth agency was created, and the instructions for control and accounting of losses and impoverishment in ore mines were published (10 April 1958) the drive started for accurate determination of impoverishment and its decrease. Most mines achieved some success, although not enough. In comparison with 1958, impoverishment for the first half of 1959 decreased by 0.7 percent according to reports. This produced a saving of 4 to 5 million leva. Investigations showed that most mines do not carry out a systematic drive for the decrease of impoverishment. The more important technical-organizational reasons for allowing a large above-plan impoverishment are the following:

Incorrect Determination of the Percentage of Unavoidable Impoverishment. According to adopted practice, the annual unavoidable impoverishment is determined by adding the estimated amount of impoverishing rocks to ore reserves that are subject to mining. Usually 10 cubic meters (cm) of country rock which is going to be mined with the ore bed is added to the latter. In determining the estimated impoverishment, the existing mining-geological conditions (stope, gallery, etc.) are not taken into account. Investigations also showed that in determining the percentage of estimated annual impoverishment, the sectors with poor veins (under 0.40 meters), barren areas, and impoverishment from assays and exploration work are not taken into account. Thus a lower percentage of impoverishment than actually exists is estimated and reported. This confuses the mine management with respect to the existing impoverishment and prevents it from organizing methods of decreasing it. A good example of incorrect estimation and reporting of impoverishment exists in the Strashimir mine of the Gorubso DMP. On the basis of average ore thickness in blocks and existing impoverishment, (adding 10 cubic meters of country rock) the mine estimated and reported 11.2 percent

impoverishment for 1958. An investigation showed this to be 38.5 percent. The 27.3 percent difference is due to the fact that, in calculating the existing impoverishment, the barren areas, which occupy 20 to 30 percent of the total mined area (coefficient of mineralization is 0.7 to 0.8) were not taken into account. Similar cases of incorrect estimation and reporting exist in a number of other mines, where the coefficient of mineralization is below one, a part of the ore-bearing zone is thinner than the workable thicknesses stated by the TB [not identified] regulations.

In the mines of Burgas Copper Ore DMP Vu'rli bryag branch, the estimated impoverishment for 1958 is decreased by a few percent, because impoverishment due to exploration (gallery, stopes, winsors), amounting to 50 percent and more, was not accounted for.

Low Quality of Drilling-Blasting Work. Investigations showed that the largest part of the high estimation of impoverishment is due to poor drilling-blasting work. Preliminary charts for drilling-blasting work are prepared in most mines. These charts are only standard types, unadjusted to the existing mining-geological conditions and variations. Drilling is done on the miners' personal judgment, and in most cases is not coordinated with the grid charts. The supervisory work of shifts is small and insufficient.

The engineers appointed for drilling-blasting work (Gorubso DMP, etc.) busy themselves with receiving and controlling the quality of explosives and not with the explosion effect and its influence on impoverishment. As a result of such practice, impoverishment in some sectors reaches more than 50 percent, instead of the estimated 8 to 10 percent (with normal ore thickness and strong country rock). Thus, in some mines of the Burgas Copper Mine, Madzharovo, Zapadni mini DMP's, etc., where the ore bed is 1.0 to 1.5 meters thick with strong country rocks, the mined thickness reached more than 2 meters, and the actual impoverishment about 50 percent because of faulty drilling-blasting work.

Unsuitable Methods of Work for Specific Mining-Geological Conditions. In the Shadiytza mine of the Gorubso DMP, the mining of weak veins, 40 to 50 meters thick, is done by the room and pillar method. This system entails an unavoidable impoverishment of 48 percent for 1958. When it was replaced by selective grading, the impoverishment dropped to 24 to 25 percent. In the Dimov dol and Golyam Palas mines, the mining

of thin and irregularly mineralized veins is done by the layer method instead of selective stoping. Here impoverishment was 27 to 49 percent for separate blocks. In the Ustrem mine, Yambol Okrug, the total blasting method was used for mining a thick, highly argillaceous, oxidized lead-zinc ore. The extraction of argillaceous ore, compared to the poor and brittle country rock, is difficult, and this has led to an impoverishment of more than 50 percent. Also, a great amount of argillaceous ore has been abandoned as impossible to extract. In some sectors of the Madzharovo, Khaskov, and Strashimir-Madan DMP's, where mineralization is highly irregular (mineralization coefficient 0.6 to 0.8), unselective stoping methods were used, in which great amounts of bare rocks occupying often 10 to 20 meters of the stope, were mined. In the Ribnitsa mine of the Gorubso DMP, a bed of variable thickness along strike and dip was mined according to the shield method, with an impoverishment of up to 40 percent.

Wrong Application of the Adopted System of Work. In the Gradishte and Gyugyurska mines of Gorubso DMP, in cases of blocks made of weak country rocks, mining is carried out by the system of lateral filling. As a result, the country rocks of the overlying ore bed are shattered, and a considerable amount of them fall during blasting. Here impoverishment reaches to 50 percent. For the same reason, in Sector No 3, at the 823 level in the Gradishte mine, where the ore bed is 0.50 meters, actually up to 3.5 meters were mined out, with an impoverishment of more than 88 percent. Similar cases exist in the Gyudyurska mine. In the Elshitzza mine of the Panagurski DMP the copper-quartz zone is stoped without supporting the footwall which is subject to mining. A great deal of barren rock ore is blasted together with the supporting pillars and mixes with ore, which considerably increases the impoverishment percentage--to 23.3 percent from a planned 8 percent. In the Zlata mine of Zapadni mini. DMP in Trin, the magazine system was used, without supporting pillars, in mining gold-bearing quartz veins of average thickness. Here the country rocks are fractured by numerous microfaults, particularly in the hanging wall. As a result of this, impoverishment reached 50 percent, particularly in places where drilling-blasting work was badly done. For instance, in block 5 at the 1,023 level, where the ore bed is 1.92 meters thick, actually 3.00 meters were mined, at an impoverishment of more than 50 percent.

Slow Clearance Work. Slow clearance in winsors creates the possibility of prolonged action of the excavated rocks on the ore bed. As a result, the footwalls fracture, fall and increase the impoverishment percentage of the ore. This is particularly characteristic of the chamber system without pillars, used in mining veins of average thickness and fractured country rocks. Investigations showed that slow working in the head wall gives a higher impoverishment than intensive operations. For instance, in the Zlata mine of the Zapadni DMP, at a mining rate of 10 meters per year, the impoverishment reached to 50 percent because of weakening and caving in of the headwall that was densely microfractured. Similar cases are observed in sectors of the Gorubso DMP and the Burgas Copper Mine DMP.

Slow and Faulty Extraction of Blasted Blocks Mined by the Chamber Method without Pillars. The slow and irregular excavations of fully mined chambers weakened the walls and resulted in cave-ins of barren rocks, increasing the impoverishment percentage. In some totally excavated chambers in the Zlata mine of the Gorubso DMP and Burgas Copper Mine DMP, where extraction of the blasted ore takes months and years, considerable amounts of barren blocks fall from the hanging walls. With their large volume, they block the tunnels and create losses from incomplete extraction. In other cases (in the Zlata and Ustrem mines, etc.), barren rocks which fall from the walls are extracted instead of ore.

Lack of Reports Concerning the Movement of Stopped Ore in Excavated Sectors. In the mines of Vu'rli Bryag belonging to the Burgas Copper Mines DMP the amount of stopped ore is not accounted for. Thus, very often, after extracting all the ore, mining operations continue in the barren country rock. In the Zlata mine, owing to slow and irregular mining in block 5-B and the consequent cave-in that blocked part of the tunnels, impoverishment reached up to more than 50 percent.

Lack of Local Projects for Mining Separate Blocks. In most mines there are no local projects for mining separate ore beds according to the specific mining-geological conditions. This prevents the arrangement of specific charts for drilling-blasting work, the anticipation of geological irregularities, and the planning of the economically workable thickness of the ore bed. In the Zlata mine, in block 5-B, mined without a specific plan, where the ore bed is 1.92 meters thick, the actual worked thickness reached up to 3 meters, with a 36.1 percent impoverishment. In places where local plans are made

(Gorubso, Burgas Copper Mines, and some other DMP's), they are perfunctory, incomplete, and not coordinated with the concrete and expected mining-geological conditions. Also, the plans do not contain one of the most important factors for correct drilling-blasting charts, which is the probable workable thickness, deduced from geological data and contour work. Therefore, the unavoidable impoverishment is not realistically determined, and there are no means for accounting for the actual impoverishment and making arrangements for its decrease.

Insufficient, Poor Quality, or Badly Made Geological Reports. In nearly all mines, the geological reports from contouring data are well made and sufficient for determining the amount and quality of proven reserves. In mining separate blocks, additional geological investigations are carried out by assaying beds, at different intervals, along the strike and dip. In some enterprises (e.g., in the mines of the Vu'rli Bryag branch) graphic charts are constructed and reviewed separately for each block. This allows tracing of the variation in mineralization in the block and correction of its ore and metal contents. In the Gorubso DMP and some other enterprises, assaying is carried out without regularly calculating the extracted reserves. In other enterprises ore beds are not assayed at all. The lack of good and sufficient assay work is a major barrier in calculating the actual impoverishment and adopting methods for decreasing it. Often, owing to a careless measurement of the worked ore beds, greater bed thicknesses are reported in order to obtain lower impoverishment (in mines of Madzharovo, Gorubso, and other DMP's).

Lack of Ore Sorting in Mines and on the Surface. In most mines, ore sorting is not used as an efficient means for decreasing impoverishment. In some mines sorting is done on the surface. It has been proved that in the latter the impoverishment percentage is considerably decreased in ores supplied for enrichment. During 1958, in the Severni Rhodope mine of Gorubso DMO 10,000 tons of gangue was sorted on the surface, which meant a saving of 1.5 million leva to the enterprise. In the Vu'rli Bryag mine, 9,000 tons of rocks were separated in surface sorting, which gave a saving of 1.3 million leva.

Non-Application of Selective Sorting in the Separation and Preparation Works. By adopting the room and pillar method of mining in the barren blocks of beds with low mineralization coefficient (0.6 to 0.7) in the Strashimir and Madzharovo

mines, impoverishment can be decreased by not less than 10 percent. This mining method adopted in the mines of Chiprov-tzi DMP considerably helped the decrease of impoverishment. Selective sorting is insufficiently adopted in clearing procedures during stoping. In non-metallic mines (barite, fluorite, asbestos and others) a commercially good product is obtained by applying selective manual sorting. In the Shadiytza mine of the Gorubso DMP, impoverishment decreased from 48 to 25 percent after changing from the room and pillar method to the headwall and filling method. This method is used almost nowhere in preparatory works, even when the ore vein is less than one meter thick (in the Vu'rli Bryag and Gorubso DMP mines). It has been determined that the great percentage of impoverishment in Vu'rli Bryag comes from the ore obtained in preliminary work, where the impoverishment is about 50 percent. For 1958 at an average impoverishment of 29.6 percent for clearing work, the total impoverishment is about 31.4 percent--that is, an increase of 2 percent because of not applying selective separation in preparatory work.

Lack of a Coordinated and Directed System of Planning and Financing the Running of Mines. The mines are given a plan for ore extraction and a financial plan for production without taking into account the metal content. With this system, the mines that obtain metal from a lesser amount of ore (by decreasing impoverishment) get a smaller grant than those getting the same amount of metal from more ore (with a greater impoverishment percentage). This system does not stimulate the mine executives to obtain less ore with a greater metal content.

Lack of a Correct Wage System for Paying the Miners in Clearing Work. Miners are usually paid per ton or per cubic meter of ore, regardless of the impoverishment percentage. The workers who do a poorer job obtain a larger amount of ore, but with a lower metal content, and get higher pay than those who work better--i.e., who get better ore with a higher metal content. It has been determined that, in the copper-quartz zone of the Elshitsa mine of Danagyursky DMP mine, 3,500 tons of barren rock was produced over the plan because of the absence of a floor in the cave-in level and because the miners were paid per ton of ore, without taking into account its quality. In the Radka mine of the same company, miners were paid for great amount of rocks which were obtained from old fill-ups. In the mines of the Vu'rli Bryag branch, after the trial introduction of a wage system which takes into account ore mineralization, impoverishment dropped

from 40 percent in the first quarter to 20 percent at the end of the year. This shows how important it is to pay miners according to a system that stimulates the production of a lesser amount of ore, but of higher quality and a lower impoverishment percentage. This is particularly important in mining by the room and pillar method, which is used in most Bulgarian mines.

Insufficient Control by the Executive, Engineering-Technical and Supervisory Personnel. The shift managers, with few exceptions, do not supervise the drilling-blasting work, which has to be done according to the predetermined chart. They do not indicate the changes in the chart which are necessary as the mining-geological conditions appear to vary. Because the activity of a shift is more apparent from the amount of ore produced, the shift managers concentrate their attention mainly on the amount of ore produced. The blasting managers do not actually supervise and help miners to do correct drilling-blasting work, but only transport explosives.

Lack of Accounting of the Loaded Ore and Assaying. The lack of such reports makes it difficult to follow the impoverishment, particularly impoverishment after self-subsidence in the rooms. Geologists assay every ten days and indicate the geological and workable thickness of the ore bed. They report the amount of gangue for that period but do not help sufficiently in the immediate plans for decreasing impoverishment. The great amount of clearing operations spread on many levels prevents a centralized and permanent control for decreasing impoverishment. Ore grading is in most cases poorly done and does not give a clear picture of the metal content in the produced ores that could be compared with the metal content of the deposit, or of the ores produced for a certain period of time. This hinders considerably the determination of the actual impoverishment and the planning of ways to decrease it. Often, because of poor grading and no account of the production, paradoxical cases occur: the amount of metal in the produced ore for a certain period of time appears to be greater than the amount of ores extracted since the beginning of production.

Lack of Methodical Scientific Research on the Influence of Drilling-Blasting Work on Impoverishment. The Scientific Research Institute for the Coal and Mining Industry has hardly touched this important question, which is essential to a radical solution of the impoverishment problem in the Bulgarian mining industry. During 1958, the Institute carried

out fragmentary observations in Burgas Copper Mines DMP and some of the mines of Gorubso DMP in order to determine the influence of drilling-blasting work on impoverishment, but the program was not completed. There are no scientific investigations on the influence of the adopted exploitation methods on impoverishment under specific mining-geological conditions that are characteristic of Bulgarian mines. No technical-financial programs have been instituted to determine the best percentage of planned impoverishment in conjunction with the adopted system of exploitation, ore transport expenditure, beneficiation costs, etc., in terms of the price of one ton of metal concentrate. These questions are not touched upon by the engineering-technical personnel in the production sectors of the enterprises. The Mining-Geological Institute gives little attention in its scientific sections to the study of the causes of impoverishment in Bulgarian mines and determining the optimum percentage of inevitable impoverishment in them. At present, the control over impoverishment is still in the hands of the geological divisions of enterprises and mines. As the divisions are dependent on the executive engineering-technical personnel that is directly responsible for production, in the majority of cases their control is reduced to registering the impoverishment.

In order to improve the work in mines and carry out a systematic program for the decrease of impoverishment, the efforts of the engineering-technical mine workers, the research institutes, and the Mining-Geological Institute have to be concentrated on the solution of the following questions:

1. Correct determination of the inevitable impoverishment in concrete mining-geological conditions, the adopted methods of exploitation, and other technical and economic factors that determine the price of one ton of metal in the concentrate. In determining the percentage of inevitable impoverishment, the following must be taken into account: inevitable impoverishment from falling rocks in opening the ore body; impoverishment from country rocks in the mining operation of ore beds according to PTE [not identified]; impoverishment in extracting weak ore bands, veins, and barren rock; and impoverishment from preparatory mining work where there is no possibility of grading. Mathematical statistics must be used to determine the average and admissible working thickness.

2. Preparation of good charts for the drilling-blasting work, taking into account the specific mining-geological conditions; strict control of the execution of the charts; intro-

duction of a wide application of millisecond blasting and a decrease in the diameter of the blasted holes. Observations by the Academy of Sciences of the USSR in some mines with very large holes (60 to 80 percent impoverishment) showed that in holes with a smaller diameter the impoverishment percentage decreases by 20 to 30 percent. It is also important to stop the fire method of igniting explosives, which is used by some mines.

3. Investigation of the methods of exploitation used and replacement with others that will ensure a lower inevitable impoverishment, taking into account the price of one ton of metal in the ore and the produced concentrates; particular attention to the efficiency of the widely adopted room and pillar method in those mines (with weak country rocks, low mineralization coefficient, etc.) where there is a larger percentage of impoverishment.

4. Prevention of poor application of the adopted methods of exploitation such as filling up without pillars in veins of average thickness and weak country rocks, failure to make a floor in layer mining, etc.

5. Introduction of the most effective separation and magnitude of blocks, in order to ensure maximum extraction; avoidance of work on many levels and blocks, which does not allow maximum extraction.

6. Full extraction of the mined ore from shafts, and the use of graphs for this purpose.

7. Introduction of precise accounts for the extraction of ore from shafts.

8. Preparation of qualitative local projects for the extraction of separate blocks, taking into account the specific mining-geological conditions based on geological data, contouring, and other additional mining and technical information; precise determination and maintenance of the workable thickness of the ore beds.

9. Improvement in the quality of geological assaying and preparation of instructions for conducting geological work, in close association with the specific conditions of the ore deposit; processing as soon as possible of the data from drilling cores. The changes in mineralization (thickness, metal content, faults, etc.) must be reported in time in

order to alter the local projects and prepare means of decreasing impoverishment and ore losses.

10. Introduction of grading on a wide scale in shafts, dumps, and in the flotation piles; investigation of means of adopting mechanical grading in heavy suspension, and other novelties in enrichment techniques.

11. Introduction of compulsory grading in mining weak veins during preparatory work. In barren sectors and sectors with a low coefficient of mineralization, mined by the room and pillar method, additional dumping space must be created for the accumulation of barren rocks.

12. Improvement of pillaring in overhead, square set, and stripping work; introduction of compulsory timbering in square set and stripping operations. In sectors with layered country rocks mined by the room and pillar method, bolt and timber supports must be introduced.

13. Investigation of the possibility of grading during loading and introduction of accurate accounting in every sector.

14. Improvement in the working methods of shift and sector managers concerning the problems of decreasing impoverishment. The former should be relieved from the obligation of being primarily responsible for the hauling ore, by introducing special jobs for ore haulers. The geological staff should be relieved of the responsibility of supervising ore impoverishment; this should be delegated to the production departments. Where such departments do not exist, the positions of engineers of impoverishment and losses should be created and filled by those who have the necessary qualifications in mining operations. The geological departments should be left only with the obligation of collecting and processing materials for the determination of the actual impoverishment.

15. The financing of mines and miners' salaries should be evaluated on the basis of tons of metal, taking into account the possible and actual impoverishment.

16. The Mining Scientific-Research Institute of the KP [not identified] should start systematic investigations to determine the most efficient exploitation methods for decreasing the impoverishment percentages and determine the most suitable maximum percentage of unavoidable impoverishment.

ment, according to the conditions in Bulgarian mining enterprises, in order to obtain the lowest cost per ton of metal in ore and concentrates.

17. Introduction of a special department in the Mining-Geological Institute for losses and impoverishment in ore mines. This department should study in detail the causes of impoverishment found in the various mining methods adopted by Bulgarian companies. The same institute should institute a few yearly correspondence courses on the subject of losses and impoverishment in Bulgarian mines.

The timely solution of these problems, the control which will be imposed by the engineering and technical personnel in mines and enterprises as well as the "Preservation of the Earth's Crust" agency, will undoubtedly improve working conditions in the mining enterprises and decrease the impoverishment which brings considerable losses to the Bulgarian economy.

CZECHOSLOVAKIA

Retail Price Reduction Announced

[The following is a translation of a Resolution published in Zemedelske noviny, No 98, 23 April 1960, Prague, pages 1-2; CSO: 4170-N]

Resolution of the Czechoslovak Government: Cheaper Electricity for Households; Textbooks and School Supplies for Students and Apprentices Free; Increase of Some Old Age Pensions

The Czechoslovak Government, following the lead of the resolution of Central Committee of the Czechoslovak Communist Party, decreed, on the basis of successful achievements in the development of the national economy--particularly in industrial production, further measures aimed at raising the standard of living of the population.

A. The Czechoslovak Government announced the reduction of retail prices of the following foodstuffs and industrial goods, effective 24 April 1960:

I. Foodstuffs

1. Sugar

Lump sugar, from 9.60 koruny to 9 koruny per kilogram
Granulated sugar, from 8.80 to 8.40 koruny per kilogram
Confectioner's sugar, from 9 to 8.40 koruny per kilogram

2. Rice

Selected quality, from 10 to 8 koruny per kilogram
First quality, from 6 to 5 koruny per kilogram
Second quality, from 5 to 4 koruny per kilogram

3. Canned Fish

Herring in oil, 320-350 gram can, from 9 to 6 koruny
Halibut in oil, 32-350 gram can, from 10 to 6 koruny
"Skrumbria" in oil, 450-470 gram can, from 14 to 9 koruny
Halibut in tomato, 320-350 gram can, from 6.20 to 4 koruny
Baltic herring in tomato, 320-350 gram can, from 5 to
4 koruny
Herring in tomato, 230-250 gram can, from 3.80 to 3 koruny
Sturgeon in tomato, 320-350 gram can, from 6.50 to 5 koruny
Herring in natural juice, 320-350 gram can, from 5.50 to
4 koruny
Haddock liver in natural juice, 320-350 gram can, from 11
to 9 koruny
Baltic herring in oil, from 14 to 9 koruny

4. Candies

Fondant pralines, per kilogram, from 36 to 33 koruny
Soy nougat, per kilogram, from 52 to 40 koruny
Jelee [Turkish candy?] with fruit flavor, per kilogram, from
33 to 25 koruny
Peanut delight, 100-gram bar, from 3.70 to 3 koruny

5. Syrups

Blackberry syrup, 0.9 kilogram bottle, from 7 to 6 koruny
Forest mix, 0.9 kilogram bottle, from 6.60 to 5 koruny
"Sport" syrup, 0.9 kilogram bottle, from 7 to 6 koruny

6. Stewed Fruit

Apricot halves, superior quality, 880 gram jar, from 11.50
to 10 koruny
Greengage plums, superior quality, 880 gram jar, from 7.70
to 5.50 koruny
Whole plums, superior quality, 880 gram jar, from 6 to 5.50
koruny
Cherries, superior quality, 880 gram jar, from 8 to 7 koruny

7. Coffee

Coffee, 100 grams, from 15 to 14 koruny
Fine mix, 100 grams, from 17 to 16 koruny
Selective mix, 100 grams, from 19 to 18 koruny
Extra special, 100 grams, from 22 to 20 koruny

8. Tea

Georgian tea in original packing, superior quality, 50 gram package, from 11 to 10.50 koruny
Chinese tea, superior quality, 50 gram package, from 9 to 8.50 koruny
Asia mix, 50 gram package, from 7.50 to 6.50 koruny

II. Clothing

9. Suits, Dresses and Coats

Men's suit, single-breasted, half wool:

size 44-48, from 305 to 290 koruny
size 49-54, from 314 to 290 koruny
size 55-63, from 322 to 290 koruny

Men's suit, single-breasted, 70-percent worsted:

size 42-49, from 870 to 800 koruny
size 50-56, from 900 to 800 koruny
size 57-63, from 930 to 800 koruny

Men's winter coat, single-breasted, half wool:

size 44-48, from 370 to 310 koruny
size 49-54, from 403 to 310 koruny
size 55-63, from 432 to 310 koruny

Ladies' summer coat, "enfolded," 70-percent carded wool:

size 42-49, from 417 to 380 koruny
size 50-56, from 488 to 380 koruny
size 57-63, from 547 to 380 koruny

Ladies' dress, half wool:

size 42-49, from 200 to 155 koruny
size 50-56, from 226 to 155 koruny
size 57-63, from 245 to 155 koruny

Ladies' summer dress, cotton, long sleeves:

size 42-49, from 69.60 to 60 koruny
size 50-56, from 79 to 60 koruny
size 57-63, from 89 to 60 koruny

Ladies' dress, rayon, long sleeves:
size 42-49, from 87 to 74 koruny
size 50-56, from 94 to 74 koruny
size 57-63, from 101 to 74 koruny
Ladies' dress, silk, short sleeves:
size 42-49, from 185 to 160 koruny
size 50-56, from 203 to 160 koruny
size 57-63, from 221 to 160 koruny
Children's coat, rabbit's hair lining, from 410 to 300 koruny
Ladies' coat, dyed rabbit fur, cut against the grain, from
3,600 to 3,200 koruny

10. Woolen Fabrics

Suiting material, 100-percent wool, double linen, from 479
to 400 koruny
Suiting material, 100-percent wool, flannel, from 423 to
350 koruny
Suiting material, 70-percent wool, multi-colored weave, from
300 to 230 koruny
Ladies' dress material:
worsted, 70-percent wool, from 140 to 120 koruny
carded yarn, 70-percent wool, from 100 to 80 koruny
Soft coat material, 100-percent wool, from 280 to 220 koruny
Coat material, half wool, from 140 to 120 koruny
Winter coat velours, 100-percent wool, from 350 to 320 koruny

11. Cotton Fabrics

Dress fustian "Narvik," width 80 centimeters, from 16.60 to
14 koruny
Damask maxim, width 140 centimeters, from 35 to 30 koruny

12. Silk Fabrics

Printed dress material, silk, width 90 centimeters, from 47
to 40 koruny
Shantung, solid, silk, width 90 centimeters, from 49.50 to
49 koruny
Taffeta, silk, width 90 centimeters, from 55 to 45 koruny
Brocade, silk, width 90 centimeters, from 64 to 55 koruny
Dress material, colored weave, rayon, width 90 centimeters,
from 15.50 to 14 koruny

Printed dress material with cut, width 90 centimeters, from 16.10 to 14 koruny
Printed "Flamisol," rayon, width 90 centimeters, from 20.10 to 18 koruny
Georgette crepe, rayon, width 90 centimeters, from 19.80 to 16 koruny
Erocaaded rope material, rayon, width 90 centimeters, from 34 to 28 koruny
Fabrics for quilted blankets, rayon, width 90 centimeters, from 26 to 22 koruny

13. Knitted Underwear and Cotton Wear for Women:

Slip with straps, "Jelena" brand, from 16.70 to 14 koruny
Pants, "Janata" brand, from 14.40 to 12 koruny
Slip and pants set, "Milena" brand, from 33 to 26 koruny

Cotton Wear for Men:

Shorts, "Ogar" brand, from 10.50 to 8 koruny
T-shirts, short sleeves, "Janko" brand, from 12 to 10 koruny

Ladies' Rayon Wear:

Slip, printed, "Heda" brand, from 28 to 24 koruny
Pants, printed, "Hana" brand, from 14.20 to 9 koruny

Pants for children from 2 to 6 years, "Marian" brand, from 28 to 24 koruny
Lumber-jacket for children from 2 to 6 years, "Palo" brand, from 36 to 30 koruny
Women's lumber-jacket, "Stefanie" brand, from 85 to 55 koruny
Men's lumber-jacket, "Zolo" brand, from 90 to 60 koruny

14. Stockings and Socks

Ladies stockings, cotton, "Zora" brand, from 5.60 to 4.50 koruny
"Lydie" brand, from 8.10 to 6 koruny
Woolen, "Mercedes" brand, from 15 to 11 koruny
"Mirka" brand, from 20 to 13 koruny
Men's knee socks, cotton, "Derby" brand, from 7.60 to 6.50 koruny
"Viktor" brand, from 10 to 7 koruny
Sport socks, "Sport" brand, from 10.70 to 8 koruny
"Kamil" brand, from 14 to 10 koruny
Woolen socks, "Sadko" brand, from 20 to 14 koruny

Men's casual socks, cotton, "Rudolf" brand, from 6.80 to 4.50 koruny

"Rosta" brand, from 5.70 to 4 koruny

Woolen socks, "Merino" brand, from 8.80 to 7.50 koruny

"Vlada" brand, from 7 to 6 koruny

15. Piece Goods

Linen dishtowels, 50 x 50 centimeters, from 5 to 4 koruny

Men's handkerchiefs, solid or half colored, from 5.30 to 4 koruny

Women's scarves, silk, 80 x 80 centimeters, from 56.30 to 46 koruny

Plastic apron for women, from 24 to 20 koruny

Children's blanket, flannel, 70 x 90 centimeters, from 14 to 10 koruny

Flannel blanket, large, 150 x 200 centimeters, from 56 to 46 koruny

Hand knitting yarn, "Slavka" brand, from 160 to 140 koruny per kilogram

16. Household Textiles

Hand-made rugs from Bulgaria, one square meter, from 700 to 500 koruny

Material for curtains, woven, width 150 centimeters, from 19.20 to 15 koruny per linear meter

Material for curtains, galloon, from 21.60 to 15 koruny per square meter

"Karamania" sofa afghan, 140 x 260 centimeters, from 216 to 165 koruny

17. Leather Goods

Briefcase, pigskin, from 226 to 170 koruny

Briefcase, imitation leather, from 85 to 70 koruny

Handbags, pigskin, dyed, from 105 to 85 koruny

box, from 150 to 85 koruny

goat-leather "Nappa," from 165 to 120 koruny

Handbag, plastic, from 90 to 60 koruny

Handbag, "PVC" velours, from 60 to 45 koruny

Bag, pigskin, from 165 to 140 koruny

Bag, cloth, from 60 to 50 koruny

Bag, imitation leather, from 99 to 90 koruny

Bag, "PVC" velours, from 65 to 50 koruny

III. Household Appliances

18. Electrical Appliances

- Vacuum cleaner, cigar shape, without box, "Standard" type,
from 660 to 600 koruny
"Merkur" floor polisher, from 1,150 to 980 koruny
Washing machine without separator, "Virena," from 1,000 to
900 koruny
Washing machine for soft laundry, "Pradlenka Romo," from
550 to 470 koruny
Robot-mixer, "UKS-E 20," with five attachments, from 1,413
to 1,078 koruny
Electric shaver, "Alfa Solunal," from 170 to 130 koruny

19. Sewing Machines

- Household sewing machine, walnut case, from 2,100 to 1,900
koruny
Bordering sewing machine, walnut case, from 3,400 to 2,750
koruny
Portable sewing machine, with case, from 2,850 to 2,100
koruny

20. Baby Carriages

- Deep baby carriage, quilted, from 590 to 480 koruny
Basket weave, from 660 to 580 koruny
"Sport" baby carriage, quilted, from 300 to 250 koruny
Basket weave, from 396 to 330 koruny

21. Stainless Steel Kitchen Ware

- Pot, 2 liters, from 125 to 80 koruny
Pan, 2 liters, from 115 to 80 koruny
Ladle, 8-centimeter diameter, from 26 to 22 koruny

22. Cutlery

- Spoon, fork, knife, and teaspoon set, stainless steel, type
24, from 63.45 to 48.50 koruny
Type 106, from 62 to 39 koruny
Spoon, fork, knife, child's set, stainless steel, from 23
to 18 koruny

23. Other Household Appliances

Hand dough mixer, from 120 to 100 koruny
"Club" stove, enameled, from 500 to 380 koruny
Light fixture, metal, for five bulbs, from 300 to 260 koruny
Night lamp, metal, from 85 to 70 koruny

24. Television Sets

"Manes" make, 35 centimeter screen, from 3,100 to 2,600 koruny
"Ales" make, 43 centimeter screen, from 3,950 to 3,100 koruny
"Astra" make, 43 centimeter screen, from 4,300 to 3,400 koruny
"Rubin" make, 43 centimeter screen, from 4,000 to 3,400 koruny
"Amethyst" make, 43 centimeter screen, from 4,400 to 3,500 koruny
"Narcis" make, 53 centimeter screen, from 5,300 to 5,000 koruny

25. Radios

Small size, "Junior," from 560 to 450 koruny
"Sonatina," from 650 to 550 koruny
Small size, "Tenor," from 700 to 600 koruny
Medium size, "Rondo II," from 1,250 to 1,000 koruny
"Melodie," from 1,550 to 1,200 koruny
Big size, "Variace," from 1,950 to 1,600 koruny
"Hymnus," from 2,100 to 1,700 koruny
"Filharmonie," from 2,500 to 1,950 koruny
Transistor radios, "T 58," from 980 to 680 koruny
Car radios, "Luxus," from 1,475 to 1,000 koruny
"Standard," from 1,360 to 900 koruny
"Turista," from 1,200 to 800 koruny

26. Combination Phonograph and Radio

Medium size "Poem," from 2,150 to 1,600 koruny
Big size, "Allegro," from 2,550 to 2,100 koruny
"Maestro," from 2,720 to 2,200 koruny

27. Phonographs

Four-speed, table cabinet, oak veneer, from 795 to 595 koruny
Portable, with amplifier, from 1,340 to 1,100 koruny

28. Records

Standard, 78 RPM, from 12 to 10 koruny
Long-playing, 33 1/3 RPM, from 36 to 30 koruny
Long-playing, 45 RPM, from 20 to 16 koruny
Long-playing, 16 2/3 RPM, from 60 to 48 koruny

29. Tape Recorders

"Sonet" make, portable, speaker included, from 2,650 to
2,300 koruny
"Mf 2" make, portable, speaker included, from 4,200 to
3,700 koruny

30. Cameras, Photo Supplies

"Flexaret II," 3.5, f/80 millimeter, "Metax" shutter, from
640 to 580 koruny
"Flexaret Va," "Belar" lens, 3.5, f/80 millimeters, "Metax"
shutter, from 930 to 810 koruny
"Zorkij III," "Jupiter" lens, 2, f/105 millimeters, from
1,500 to 1,300 koruny
"Moskva 5," "Industar" lens, 3.5, f/105 millimeters, from
870 to 700 koruny
"Opemus] magnifier, 6 x 6 centimeters, from 615 to 490 koruny
"Axomat," 24 x 36 centimeters, from 640 to 490 koruny
"Magnifax," 6.5 x 9 centimeters, from 785 to 600 koruny

31. Toys

Metal scooter, chromodized, from 130 to 110 koruny
Metal tricycle, free-wheel, from 230 to 180 koruny
Doll carriage, deep, quilted, from 330 to 250 koruny
Sporting doll carriage, quilted, folded, from 130 to 110
koruny
Washing machine, "Perotka" flywheel, from 38 to 32 koruny
Doll with closing eyes, 40 centimeters high, from 145 to
95 koruny

Wind-up car, from 57 to 42 koruny
Electric car, remote control, from 125 to 110 koruny
Plane, polystyrene, flywheel spring, from 32 to 19 koruny

32. Writing Supplies

"Zeta" typewriter, portable for travel, from 1,400 to 1,050 koruny
"Zeta" portable, from 1,690 to 1,400 koruny
Fountain pens:
 "Zak," from 10 to 6 koruny
 "Student," from 15 to 8 koruny
 "Barclay vacuum," fro, 36 to 20 koruny
 "Centropen," from 60 to 43 koruny
Set, "Centropen" fountain pen with golden point and pencil, fro, 165 to 105 koruny
"Versatil" refill pencil, from 8 to 4 koruny
"Barclay" fountain pen with golden point, from 116 to 70 koruny

V. Sporting Goods

33. Summer Sports Supplies

Tennis racket frame, "Artis," from 101 to 70 koruny
Tennis ball, from 6.50 to 5 koruny
Table tennis racket, from 37 to 30 koruny
Ping-pong table, from 597 to 450 koruny
Javelin, weight 600 grams, from 63 to 53 koruny
"Racek" tent, rubber base, from 430 to 380 koruny
Raft, rubberized fabrics, inflated, from 220 to 175 koruny
Sleeping bag, feathers, from 440 to 380 koruny
Knapsack, reed frame, from 155 to 120 koruny
Food kit with pocket, two zippers, from 31 to 25 koruny
Canoe, glass laminated, from 2,300 to 2,150 koruny
"Moskva" outboard motor, from 5,900 to 5,200 koruny
Fishing rod, two parts, glass laminated, from 117 to 100 koruny
"Roen" fishing reel, from 115 to 80 koruny

34. Winter Sports Supplies

Children's clamp skates, from 36 to 28 koruny

Hockey skates, from 66 to 50 koruny

"Artis" skis, laminated, metal edges, from 258 to 200 koruny

Seldge, ash-tree, laminated, straps, from 130 to 100 koruny

* * *

In addition to the price concession on consumer goods listed above, the retail prices of some other consumer and industrial goods were also reduced, effective 24 April 1960. These reductions will be listed in a retail price list published by the Ministry of Internal Trade. Simultaneously, there is a great retail price reduction of some discontinued makes of valuable radios, electric vacuum cleaners, and their accessories, cameras, etc..

B. The Czechoslovak Government has decreed a reduction in the basic electricity rate for households from 0.80 to 0.70 koruny per kilowatt hour effective 24 April 1960. The new rate, billed according to the electrometer records, recorded in the last counting of consumption before 24 April 1960, will be uniform for all volumes of consumption.

C. The Czechoslovak Government decided to provide for free distribution of schoolbooks and supplies to each pupil in the secondary, vocational, and apprentice-training schools in the total amount of 400 million koruny per year, effective 1 September 1960.

D. The Czechoslovak Government passed a resolution for continuation of its policy to increase some disability, old-age, and widows' pensions accorded prior to 1 January 1957, to the minimum determined by the law in the amount of 400 koruny monthly. The volume of costs needed to meet these pensions will increase by 120 million as against 1959. Decisions on increase of pensions in individual cases is left to the discretion of Social Security Commission of the Okres National Committees.

CZECHOSLOVAKIA

Radio-Range Communications on Centimeter Waves

[The following is a translation of an article entitled "Richtfunkverbindungen auf Zentimeterwellen," by Dipl Engr F. Klima and Dr Engr R. Tuhl, Prague, published in Radio und Fernsehen, Vol IX, No 5, March 1960, Berlin, pages 141-143; CSO: 4128-N/a]

Czechoslovak industry has already had many years of experience in the area of radio-range communications, and this has fully benefitted the installations which it produces for transmitting television programs. There was first of all the light, mobile MT 11 apparatus, which is used for the connection of studio and transmitter or for television reportage up to a distance of 60 kilometers. As it permitted the use of intermediate lying relay points, reportage transmission could also be sent out to far distant areas.

The second apparatus, the DT 11, is for the construction of permanent television networks. The construction design demands on the relay points are insignificant thanks to its completely worked out design; this contributes essentially to accelerating the construction of the permanent relay point networks and to decreasing the costs of the construction. The demodulation system makes it possible to switch up the signal at any given relay point.

The apparatuses are equipped throughout with noval or miniature tubes. Specially produced power klystrons with linear modulation characteristics, a higher stability of the produced frequency, and a longer service life are used as transmitting tubes.

The construction and selection of individual parts was made so that a suitable operation is possible at -20 degrees up to +40 degrees centigrade. The large number of testing points and special monitoring circuits permit constant control during operation and facilitate the quick determination and removal of disturbances.

Both types are constructed so that they can be used in addition for both local and long distance transmission of radio-bearing signals. They are also extremely suitable for use in air travel radio dispatching centers.

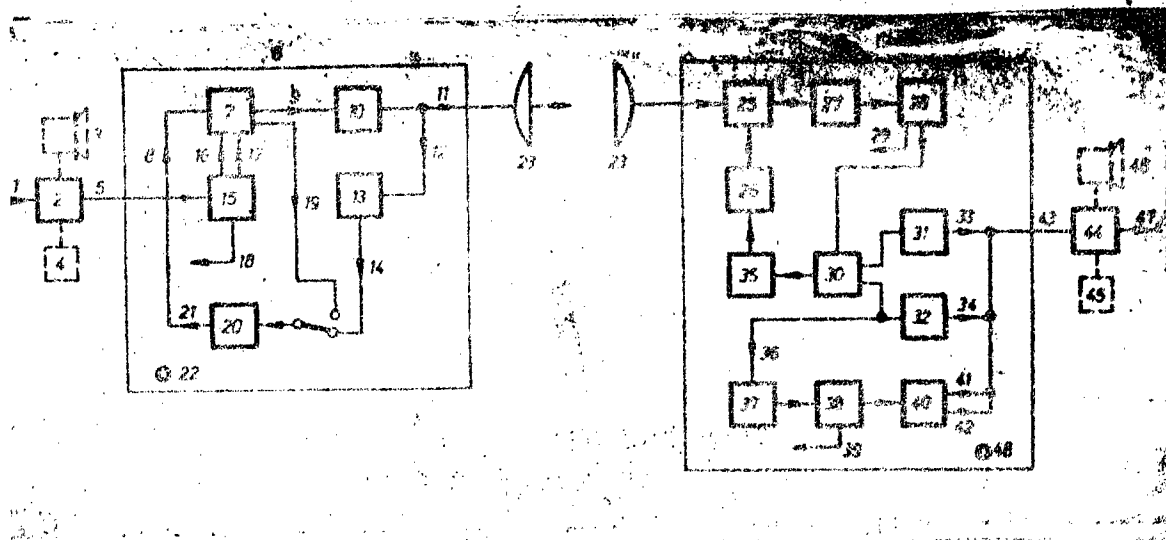

Connections Diagram of the MT 11 Unit

- 1) Connection of picture and sound signal, power-supply voltage, and telephone circuit
- 2) Transmitter power supply
- 3) Loud speaker
- 4) Picture monitor
- 5) Connecting cable between power equipment and transmitter
- 6) Transmitter
- 7) Picture modulator
- 8) Picture modulator conductor
- 9) Modulation conductor for the klystron
- 10) 750-megawatt transmitting klystron, type 20 SR 52
- 11) Tubular conductor connection for the antenna
- 12) Shunt to discriminator (13) for the 3-centimeter band, which serves simultaneously as a wave meter, and modulation amplitude meter of the video signal and of the frequency of the sound carrier
- 13) [Discriminator]
- 14) Outlet of the picture signal and the auxiliary sound carrier
- 15) Sound modulator
- 16) Outlet of the one kilohertz calibration oscillator
- 17) Outlet of the modulated auxiliary sound carrier
- 18) Measurement of the sound level and adjustment of the 8.5 megahertz auxiliary frequency
- 19) Conductor of picture modulation from modulator inlet
- 20) Control amplifier
- 21) Picture and sound outlet

- 22) Connecting socket for the telephone for the reciprocal communication of operating personnel
- 23) Antenna
- 24) Receiver
- 25) Mixing stage
- 26) Heterodyne oscillator with klystron 27 SR, 51.20 megawatts. The wave meter built into the receiver serves for the measurement of its frequency
- 27) Intermediate frequency amplifier
- 28) Limiter
- 29) HF frequency level or volume measurement
- 30) Discriminator
- 31) Picture amplifier for control purposes
- 32) Picture amplifier for monitoring
- 33) Mixing outlet
- 34) Monitoring outlet
- 35) AFC (automatic fine tuning device)
- 36) Shunt for the auxiliary sound carrier
- 37) Intermediate frequency amplifier for the sound channel
- 38) Discriminator for the sound channel
- 39) Measurement of the voltage and the amplitude of the auxiliary sound carrier
- 40) LF-amplifier
- 41) Sound outlet for mixing purposes
- 42) Sound outlet for monitoring
- 43) Connecting cable between receiver and socket-power unit
- 44) Socket power unit of the receiver
- 45) Picture monitor
- 46) Loudspeaker
- 47) Picture and sound outlet for control, power conductance, and telephone connection
- 48) Socket for operating personnel telephone connection

Radio-Range Communication Apparatus MT 11
for the 3-Centimeter Band

The "Tesla" radio-range communications apparatus MT 11 is a mobile television relay for the transmission of picture and sound from studio or mobile unit reporting car to the transmitter. Moreover, the apparatus can be used for the transmission of communications of a different nature (for example, communications expressed in the form of pulses as in radio-bearing work), in case a rapidly producible communication is necessary.

Functional Description of the Unit

In the transmitter the picture signal is amplified at $1 V_{ss}$ in a broad-band video amplifier and then conducted to the transmitter klystron. A diode in the reflector circuit of the klystron serves to regenerate the direct-current components.

The $1.55 V_{eff}$ sound signal at 200 ohms is amplified and modulated on an auxiliary carrier of 8.5 megahertz modulation. The auxiliary carrier is attached to the video signal at the klystron reflector. The frequency fluctuation of the klystron amounts to 8 megahertz for the picture signal and 2 megahertz for the auxiliary carrier.

The transmitter contains a built-in centimeter wave discriminator, which serves at the same time as a wave meter. This lightens the adjustment of the correct frequency under a frequency change or interchanging of the klystron. The transmitter also contains a monitoring unit for picture and sound which can be connected either to the discriminator circuit (thus to the transmission outlet) or to the inlet of the transmitter, to lighten the control of the inlet signal and localize any disturbances which might occur. A loudspeaker and picture monitor can be connected to the outlet of the monitoring unit so that the monitoring on the transmitting side can take place independently of the remaining operation.

The receiver is equipped with a mixing circuit which is fitted with a silicon diode. The inlet signal is converted into the intermediate frequency (band middle 130 megahertz) by means of overlapping with the frequency of the mixing oscillator. A picture signal originates at the discriminator after amplifying and limiting and is further amplified for the mixing outlet and for control. The sound carrier is shunted off at the first stage of the picture amplifier and is then amplified in the sound part at $1.55 V_{eff}/200$ ohm symmetrical outlet voltage. The receiver is equipped with an automatic fine tuning device.

The receiver also has a wave meter, four measuring instruments, and control outlets for connecting a monitor and loudspeaker, similar to the transmitter, all for the purpose of adjustment and monitoring. Points for retesting the tube functions are accessible on the inside after removing the side parts.

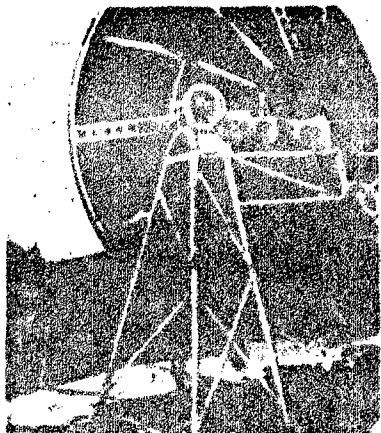

A Parabola Mirror on the
Cstrava-Bratislava Radio
Line

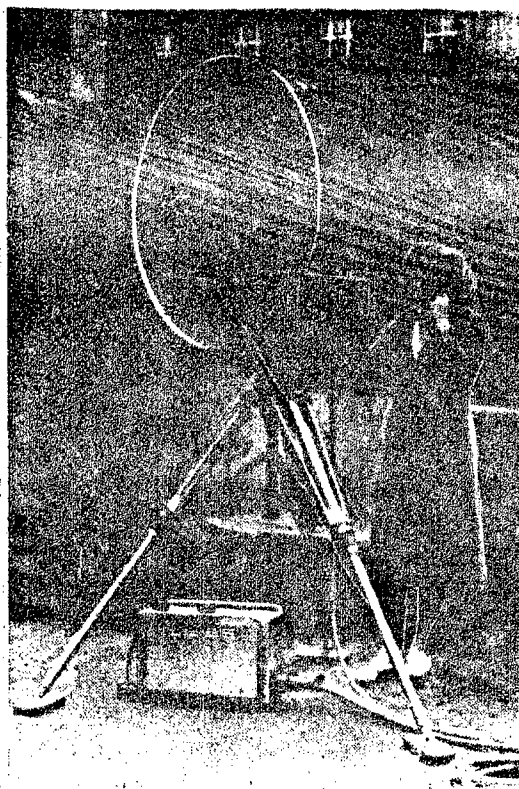

Regulation of the MT 11
Transmitter during Re-
porting

Design Construction

The unit is designed so that it can be easily assembled and disassembled. None of the individual parts weighs more than 23 kp. The transmitter (and/or receiver) can be brought directly behind the parabola mirror on the supports during mobile operation. The connecting lines to the power supply unit can be up to 120 meters long (the sum of the conductors from transmitter to receiver); conducting cables, each 60 meters long and rolled up on cylinders, are used for this purpose. Transmitter and/or receiver can be housed separately under a permanent operation; in this case a tubular conductor line is used to connect the parabola mirror antenna.

A complete transmitting and/or receiver unit for reporting purposes consists of six independent parts: parabola mirror antenna, rotor, supports, transmitter (and/or receiver), power supply unit of the transmitter (and/or receiver), conductance cable. The entire weight of a transmitter and/or receiver unit, including the parabola mirror of one meter diameter, amounts to 75 kp.

Working Conditions

The MT 11 unit can be operated in the shade under ambient temperatures of -30 degrees up to +40 degrees centigrade. The relative humidity should not exceed in the long run 85 percent. The apparatus is protected against spray water and rain. A dust-free environment should be selected for long operations in view of the half-open construction and the ventilation.

Advantages of the Apparatus

The special advantages of this apparatus are the low noise level and the insignificant cross-talk, and furthermore the equipment described earlier with monitoring installations (wave meter, discriminator for microwaves, control amplifier for picture and sound, control outlets for picture and sound). The unit may be put into operation quickly and its operation is simple. Another advantage is the small dimensions, the small weight, as well as the small space requirements. A great advantage for reporting purposes is the applicability of parabola mirror antennas of different diameters and the possibility of a simple transmission from 750 megawatts to 100 megawatt transmitting output by means of simply throwing a changeover switch in the power-supply unit. The transmitting klystron is thereby spared.

Technical Data

The power supply voltage amounts to 220 volts ± 5 percent. The carrier frequency is 8,100 to 8,500 megahertz.

Transmission range:

a) Under a 100-megawatt output generated from the klystron and a one-meter antenna diameter, the transmission range amounts to 20 kilometers for a 41 dB [decibel?] noise interval (i.e., a ratio of the point-to-point voltage of the picture signal to the effective value of the interference voltage), whereby 7 dB remains available as a reserve for automatic volume control.

b) The transmission range amounts to 35 kilometers with about 12 dB reserve for automatic volume control under a 100-megawatt klystron output and a 1.7 meter antenna diameter or

a 750-megawatt klystron output and a one-meter antenna diameter and for a noise interval of 41 dB.

c) The apparatus has a transmission range of 60 kilometers with about 16 dB reserve for automatic volume control under a 750-megawatt klystron output and a 1.7-meter antenna diameter and a 41 dB noise interval.

The rate of climb of an ideal pulse is less than 75 nona-seconds.

The picture inlet voltage amounts to 1 to 2 V_{SS} at 75 ohms, the outlet voltage 1 V_{SS} at 75 ohms.

The sound inlet voltage amounts to 0.8 to 3.2 V_{eff} at 200 ohms symmetrically, the outlet voltage 1.55 V_{eff} at 200 ohms symmetrically.

Noise interval:

a) At least 41 dB for the picture channel at normal distance (defined as the ratio of the picture voltage point-to-point to the effective value of the interference voltage).

b) At least 52 dB for the sound channel at 1,000 Hertz and 47 dB at 50 Hertz.

Cross-talk from the picture channel in the sound channel and vice-versa has already been included in the above figures.

The nonlinear distortion of the picture channel amounts to one percent; the width of the transmission band is 30 Hertz to 15 kilohertz per 3 dB.

TransmitterL

Transmission output 750 megawatts or 1,000 megawatts, by switching over the feed voltage.

Auxiliary carrier of the sound channel, 8.5 megahertz, with \pm 75 kilohertz modulation.

Transmitter control outlets: picture, 1 V_{SS} at 75 ohms, sound, 50 megawatts, 12 ohms.

Accuracy of the frequency measurement with built-in wave meter, 0.05 percent. (The frequency modulation can be read with 10 percent accuracy.)

The rate of power input is about 400 watts for a 750-mega-watt transmitting output.

Receiver:

Intermediate frequency, 130 megahertz, band width, 23 megahertz per 3 dB.

Control outlets of the receiver: picture, 1 V_{SS} at 75 ohms, sound, 40 megawatts at 12 ohms.

Accuracy of frequency measurement with built-in wave meter, 0.05 percent.

Rate of power input, about 320 watts.

Dimensions and weights:

Dimensions of the cabinets: 300 x 200 x 500 millimeters.

Weights: transmitter, 20 kp; feeder part of the transmitter, 22 kp; receiver, 21 kp; feeder part of the receiver, 21 kp; parabola mirror antenna with one-meter diameter, including attachment support, 6.5 kp; base support including the rotary head, 26 kp; smallest height of the collapsed base support, about 130 centimeters--the highest height, 170 centimeters; cable drum or cylinder for 60-meter cable, 10 kp.

The DT 11 for the 6-Centimeter Band

This apparatus is to be used for the construction of predominantly permanent television translation lines; it permits the transmission of black and white television signals according to CCIR or OIR standards, in some cases also according to standards with a smaller line frequency. The greatest transmission range by optical sight amounts to 100 kilometers.

The unit is composed of the following parts: receiver, transmitter, the accessory power supply units, tubular conductor lines, parabola mirror with 3-meter diameter, as well as other auxiliary devices for measuring and completion work (Komplettierung).

The transmitter consists of a modulation amplifier, which amplifies and processes the incoming video signal. The transit time tube, a power reflex klystron type 211 SR 51, is modulated with the amplified signal. The power output supplied by the klystron is fed to circuits which serve for lineariza-

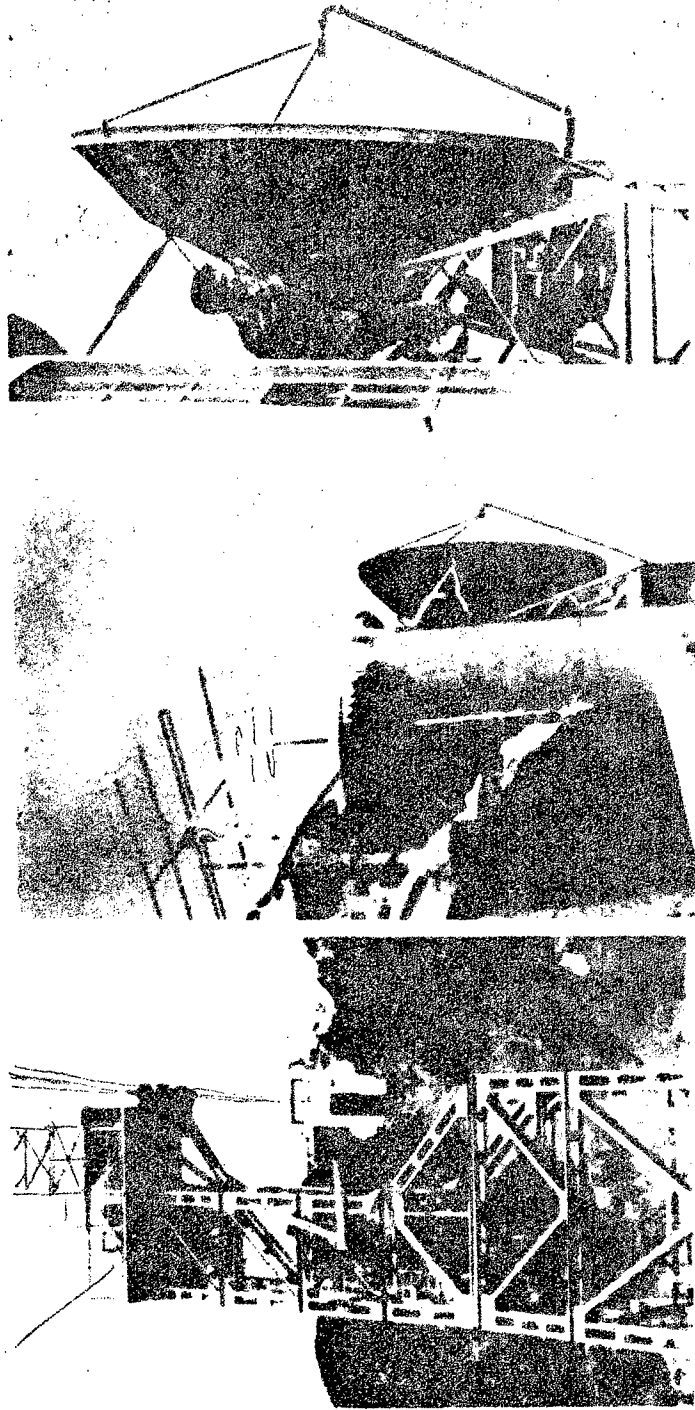

The D11 Apparatus on the Lomnitz Peak in the High
Tatras, the Highest Lying Roly Point in Czechoslovakia
(2,634 meters).

tion and over a tubular conductor line for the antenna. The transmitter's own control amplifier makes possible direct monitoring of the quality of the hf-signal sent out. In the receiver the incoming signal is in a symmetrical mixing stage overlapped on one of the auxiliary frequencies supplied from a klystron oscillator and is amplified in the intermediate frequency amplifier with a middle band frequency of 105 megahertz and 28 megahertz band width.

A linearized broad-band discriminator switch with follow-on video amplifier serves to demodulate the intermediate frequency. An automatic fine tuning device provides for the maintenance of the tuning frequency of the receiver. Level or volume fluctuations caused by fading effects are balanced with automatic volume control devices which are progressively effective.

The design of the DT 11 was selected so that the unit could also be set up and operated under very difficult weather conditions--for example, in setting up temporary connections and so on. Transmitter and receiver are therefore hermetically sealed. The air required for cooling the transmitter circulates in a closed circuit. The antenna position will hold under wind speeds of 160 kilometers per hour.

The noise background values correspond to the regulations of the CCIR for a circle of unit radius of 280 kilometers.

A tubular conductor switchover with four directions and a 0.2/55 dB transmission loss is available for a reversion of the connection or for an eventual switching-in of reserve apparatus.

Important Data on the DT 11 Unit

Frequency Band: 4,400 to 5,000 megahertz.
Transmitting output: at least one watt.
Modulation: FM at the klystron.
Intermediate frequency: 105 megahertz.
Intermediate frequency band width: 27 megahertz.
Frequency stability: $1 \cdot 10^{-4}$.
Largest frequency fluctuation: 10 megahertz.
Video inlet or input voltage: 1 V_{SS} at 75 ohms.
Range of regulation: + 14 to -10 dB.
Outlet voltage: 1 V_{SS} at 75 ohms.
Rate of climb: < 75 ns.

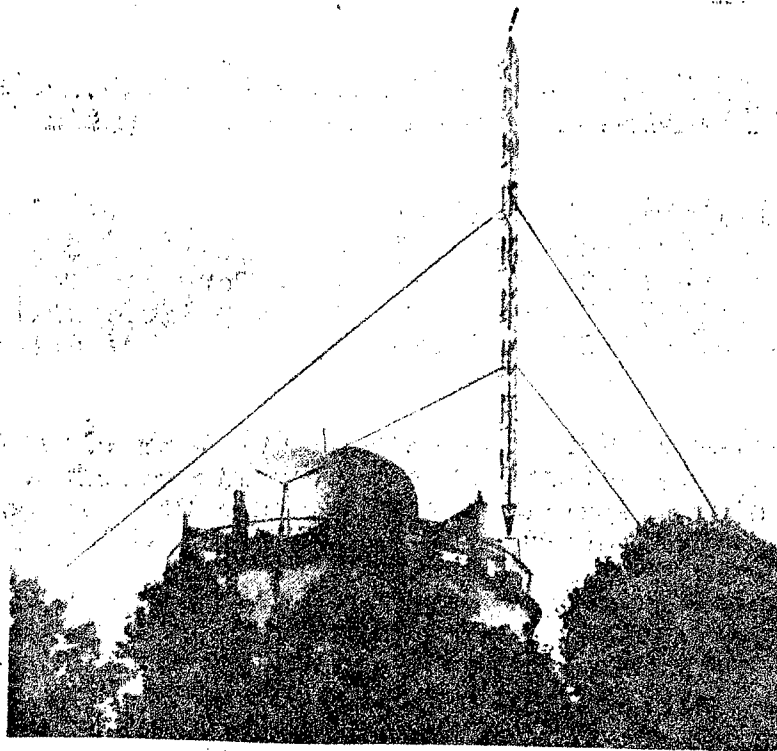

The Television Transmitter Operating on
on Band III for the Presov Area, Which Is
Supplied with Power over the Radio Relay
from Lomnitz Peak. The Parabola Mirrors
of the Receiver of the DT 11 Unit Are
Visible

Power feed: 220 volts, single-phase \pm 5 percent, 50 Hertz.

Diameter of the antenna parabola mirror: 3 meters.

Antenna system gain: 40 dB.

Total weight of the unit, including antennas: approximately
800 kp.

Total rate of power input of the unit: approximately 1.4 kilo-
volt-amperes.

CZECHOSLOVAKIA

Wood Consumption and Its Utilization in the Individual Consumer Sectors in Czechoslovakia

[The following is a translation of an article entitled "Spotřeba dřeva a jeho využití v jednotlivých sektorech spotřeby CSR," by J. Tóupal, published in Statistický Obzor, No 2, February 1960, Prague, pages 65-68; CSO: 4056-N]

The problem of wood consumption has been closely followed for some time by government and economic circles, because of the continuing disparity between actual wood exploitation and the need to conserve the exploitation capacity in wood.

The disparity is caused by the fact that actual exploitation and consumption exceed by far the [reserve] exploitation capacity in raw wood. The steady decline of our wood resources amounts to a significant loss for our national economy.

The Eleventh Party Congress dealt with the problem of economy with wood resources and set forth the following principal tasks:

- 1) elimination by 1970 of the existing disparity between wood exploitation and growth of our wood resources;
- 2) reduction by 30 of sawed lumber consumption at the end of 1965.

The tasks are mandatory, although the directives for the Third Five-Year Plan schedule a substantial rise in apartment construction, an increased volume and better quality consumer goods, higher furniture exports, and an intensified industrial production in all sectors of our national economy. The demand for wood will naturally be very strong.

At first glance the task seems impossible, but it is actually a sound project that can be carried out. It will of course entail the cooperation of all workers engaged in the exploitation, production, processing, and ultimate consumption of wood.

All sectors will be required to apply the socialist principle of economy in the use of wood. We shall promote the use of wood that is not short in supply (by substituting broadleaf wood for pine wood); reduce losses in exploitation, shipment, and in consumption, utilized wooden waste in greater measure; and, if possible, substitute other equivalent materials for wood.

We must become familiar with the domestic consumption trends of the principal types of raw wood and their utilization in the principal consumption sectors.

Statistics on domestic consumption of specific raw wood types between 1954 and 1958 reveal the following trends (in 1,000 cubic meters [plm b.k.]):

Year	Total Raw Wood	Firewood	Total Con- sumption
Pine and broadleaf totals:			
1954	13,357.0	2,821.4	10,535.6
1955	13,972.7	2,899.3	11,073.4
1956	14,072.8	3,019.7	11,053.1
1957	13,419.6	2,517.5	10,902.1
1958 absolute	13,252.6	2,204.7	11,047.9
Percentage of raw wood	100.0	16.6	83.4
1965 absolute	11,673.0	1,358.0	10,315.0
Percentage of raw wood	100.0	11.6	88.4
Decline (-)			
Increase (+)			
Compared with 1958	-1,579.6	- 846.7	- 732.9

[table continued]

[Table continued]

Year	T y p e s			
	Round Timber	Mining Timber (Dolo- vina)	Wood Fiber	Other Types
Pine and broadleaf totals:				
1954	7,287.9	981.7	1,637.9	628.1
1955	7,661.5	985.5	1,699.5	726.9
1956	7,440.0	1,066.6	1,787.1	759.4
1957	7,336.0	1,123.8	1,784.5	657.8
1958 absolute	7,287.2	1,067.6	1,956.0	737.1
Percentage of raw wood	55.0	8.1	14.8	5.5
1965 absolute	5,982.0	898.0	2,642.0	793.0
Percentage of raw wood	51.3	7.7	22.6	6.8
Decline (-)				
Increase (+)				
Compared with 1958	-1,305.2	- 169.6	+ 686.0	+55.9

The raw wood consumption rose steadily until 1956. As of 1957, a moderate decline set in as a result of the lower consumption of fuel wood. The use of round timber registered a moderate decline, and the consumption of wood fiber reveals an annual upward trend, caused by a growing demand for paper and paper products.

The tasks set forth by the Eleventh Party Congress and by the directives for the Third Five-Year Plan will be fulfilled only provided the prevailing internal structure of the various types of raw wood is altered and their consumption substantially reduced.

The data listed in the table above indicate that by 1965 the total consumption of raw wood will have to decline by approximately 1,579,600 cubic meters; the figure comprises a decline of 846,700 cubic meters in the consumption of firewood.

The change in the internal structure of wood utilization will be effected by an increase of 680,000 cubic meters in wood fiber consumption on the one hand and by a decline of 1,305,200 cubic meters in round timber consumption on the other. The consumption of wood fiber will rise accordingly from 14.8 percent in 1958 to 22.6 percent in 1965; round timber consumption will decline from 55.0 percent in 1958 to 51.3

percent in 1965 and fuel consumption from 16.6 percent to 11.6 percent in 1965.

The powerful impact resulting from the shifts between pine wood and broadleaf wood is evidenced in the following table (in 1,000 cubic meters [plm b.k.]):

Type	Total Raw Wood	Firewood	Total Utili- zation
Pine wood:			
Total	8,862.0	684.0	8,178.0
1965 increase (+) decline (-)			
Compared with 1958	- 1,647.1	- 369.9	- 1,277.2
Broadleaf wood:			
Total	2,811.0	674.0	2,137.0
1965 increase (+) decline (-)			
Compared with 1958	+ 67.5	- 476.8	+ 544.3
Share of pine wood in total consumption:			
1958	79.3	47.8	85.6
1965	75.9	50.4	79.3

Type	Total Round Timber	T y p e s		
		Mining Timber	Wood Fiber	Other Types
Pine wood:				
Total	4,816.0	868.0	2,049.0	445.0
1965 increase (+) decline (-)				
Compared with 1958	- 1,298.7	-177.2	+ 229.9	- 31.2
Broadleaf wood:				
Total	1,166.0	30.0	593.0	348.0
1965 increase (+) decline (-)				
Compared with 1958	- 6.5	+ 7.6	+ 456.1	+ 87.1
Share of pine wood in total consumption:				
1958	83.9	97.6	93.0	64.6
1965	80.5	96.7	77.6	56.1

Compared with 1958, the total consumption of raw pine wood is expected to decline by 1,647,100 cubic meters, while the consumption of broadleaf raw wood is scheduled to rise by 67,500 cubic meters.

The highest absolute rise will be registered by the broadleaf wood fiber consumption (456,100 cubic meters); the consumption of pine wood fiber anticipates an increase of only 230,000 cubic meters.

The above indicated structural changes will thus cause a general decline by 1965 in the consumption of pine wood types (except firewood) and lead to a rise in the consumption of the broadleaf wood types. The deepest decline (by 15.4 percent) will be registered by wood fiber.

In order to realize the projected reduction in consumption, a knowledge is required of the largest wood consumer sectors. The following table offers the pertinent data:

Ultimate 1957 Consumption According to Consumer Sector

A = 1,000 cubic meters; B = Percent

Consumer Sector	Wood Total	
	A	B
1. Agriculture	657.8	4.9
2. Mining industry	1,421.0	10.6
3. Woodworking industry	667.6	5.0
4. Furniture industry	382.3	2.9
5. Chemical industry	2,189.5	16.3
6. Other industrial sectors	966.1	7.1
7. Building industry	1,857.7	13.8
8. Household consumption and other branches	3,022.5*	22.5
9. Waste	1,783.3	13.3
10. Import, export, stock on hand differentials	471.8	3.6
11. Totals	13,419.6	100.0

[table continued]

[Table continued]

Consumer Sector	Raw Wood, In- cluding Wood Fiber		Processed Wood		Total Sawed Wood	
	A	B	A	B	A	B
1	183.0	2.1	474.8	10.3	474.0	12.9
2	1,199.9	13.6	221.1	4.8	145.1	3.9
3	193.3	2.2	474.3	10.2	463.9	12.6
4	-	-	382.3	8.3	222.1	6.0
5	2,189.5	24.9	-	-	-	-
6	332.0	3.8	634.1	13.7	629.3	17.1
7	340.4	3.9	1,517.3	32.8	1,301.2	35.5
8	2,571.9	29.2	450.6	9.7	440.0	12.0
9	1,783.3	20.3	-	-	-	-
10	-	-	471.8	10.2	-	-
11	8,793.3	100.0	4,626.3	100.0	3,675.6	100.0

*Comprising total firewood consumption (2,517,500 cubic meters).

The above data represent an analysis of the ultimate wood consumption in 1957 according to the principal consumer sectors. The term "ultimate consumption" is to be interpreted as the consumption of individual types of wood in their ultimate utilization by individual consumer sectors. Out of a 13,419,600 cubic meter total of raw wood, a volume of 8,795,300 cubic meters (65.5 percent) was ultimately consumed as raw wood. The balance of raw wood was first semi-processed for the manufacture of a variety of wooden products and then the processed wood was ultimately consumed in the individual consumer sectors.

The data reveal that by far the largest volume of wood is always being consumed in the form of fuel.

In 1957 the total firewood consumption amounted to 2,517,500 cubic meters or 18.7 percent of the national consumption. This justifies the principle of reducing the consumption of fuel wood in the Third Five-Year Plan and increasing its utilization in the manufacture of a variety of wooden products.

A considerable amount of wood waste is not being utilized.

According to a 1957 survey the waste that remained unutilized for further industrial processing totaled 1,857,700

cubic meters (13.8 percent), after deducting the waste utilized as substitute for fiber in the manufacture of cellulose and the waste utilized in the manufacture of synthetic boards. The directives for the Third Five-Year Plan schedule a far better utilization of the waste in the manufacture of wooden products, particularly in the manufacture of synthetic boards; this will lead to a large saving in sawed wood, the consumption of which is expected to decline by 30 percent in 1965 in comparison with the consumption of 1957.

Among the largest wood consumer sectors are the chemical industry (16.3 percent), the building (13.8 percent), and the mining industries (10.6 percent).

The mining and chemical industries use mostly raw wood, whereas the building industry consumes predominantly processed wood (32.8 percent), particularly sawed wood.

Savings of wood in the mining industry will be realized by substituting other materials, especially metal. The building industry, in addition to substituting other material for wood, will promote the use of versatile wooden products, primarily waterproof plywood (which has 40 possible uses compared with four for sawed wood). The net gain will be that one cubic meter of waterproof plywood will replace 18 cubic meters of sawed wood.

The chemical industry will be unable to realize any savings in wood because the rising paper output in the Third Five-Year Plan will be accompanied by an increased consumption of wood fiber.

The woodworking industry is a large consumer (12.6 percent) of processed wood, especially sawed wood. The consumption in this sector amounted to 463,900 cubic meters of sawed wood in 1957, with the largest part of it going into the manufacture of material for packing. We shall cut down on the consumption of wood in this sector by introducing substitutes for wood, by reducing oversized packing material, or by increasing its versatility.

The directives of the Eleventh Party Congress and of the Third Five-Year Plan requiring the conservation of our resources of wood will be aided by statistics that will disclose hidden reserves of our wood resources and follow the fulfillment of the above directives.

CZECHOSLOVAKIA

Upright Drill of the Type VV-11-R-2

[The following is a translation of excerpts from an article entitled "Vrtaci stroj na svisle vrty typ VV-11-R-2," by Engr Ladislav Osyka, published in Uhli, Vol II, No 4, April 1960, Prague, pages 134, 135; CSO: 4041-N/a]

The Institute for the Mechanization of Mining (Ustav pro dulni mechanizaci) developed a model of an upright drill of the VV-11-R-2 type for split-second action drilling of mineral and ore substances.

The drill is housed in the rear section of the S-80 conveyor tractor. The tower of the drill is collapsible and may be folded prior to transportation; when crossing uneven ground, it may be folded alongside the tractor above the caterpillar belt conveyors. Its stability during operation is secured by two strut beams which are supported by the front section of the tractor. The struts also have the function of erecting and folding the drill tower.

There are two geared pumps $Q = 250$ liters per minute and 125 liters per minute and two geared pumps $Q =$ one liter per minute and 7 liters per minute. All pumps are powered by the tractor.

The drill head consists of a 30-horsepower oil engine, transmission chamber, and conduit arms. The conduit arms conduct the drill head between the pipes of the drill head housing.

The drill head receives its up and down motion from a device housed in the lower part of the drill tower. This device consists of an 8-horsepower oil engine and a transmission chamber; the small chain wheel of the transmission chamber meshes into the Gallo chain, which, in a connection with the drill head, forms a closed circuit. The device delivers pressure power to the drill operation and the power of extracting drilling rods from the drilled hole.

Drilling Equipment and Accessories

The drilling equipment consists of three-meter long drilling rods and a terminal rod carrying the drill bit. A spiral on the circumference of the drilling rods clears drilled matter away. The cutters of the drill bit are plated with a hard metal. The accessories consist of grab-support rods and of pullers to pull out drilling rods in case they crack during the drilling operation.

The drill is used for drilling upright holes (without cleaning) in common or clayey earth and brown coal in temperatures ranging to below ten degrees centigrade on regular and also on 15 degree slanted grounds.

Technical Specifications of the Drill:

Capacity of drill head oil engine (horsepower)	30
Drill head spindle revolutions per minute	maximum 50
Pressure power of drilling rods (kilograms)	4,500
Drilling Equipment:	
Diameter of drills (millimeters)	110, 180, 300
Maximum drilling depth (meters)	30, 25, 10
Length of individual drilling rod (meters)	3
Maximum motion velocity of drill head (meters per minute)	7
Dimensions and Weight of Drill:	
Maximum length of drilling during transportation (millimeters)	5,750
Width of drill (millimeters)	2,400
Height of drill (millimeters)	5,240
Weight of drill (kilograms)	2,500
Weight of S-80 conveyor tractor (without plowshare), kilograms	11,400

The hydraulic hook-up of the drill is divided into five circuits: primary, auxiliary, control, supplementary, and waste.

* * *

In an effort to expand the function of the drill into other production sectors engaged in the working of limestone, tuff, and similar substances, the Institute for the Mechanization of Mining is developing additional equipment to permit the drilling of harder substances. The drill will have conventional drilling rods 60 millimeters in diameter and about 3 meters long, a cleaning head, and other accessories for air-cleaning. The drilling will have a diameter of 80 millimeters and an anticipated drilling depth of about 40 meters.

The drill of the type VV-11-R-2 will be manufactured this year by the Kovolis Hedvikov National Enterprise and our mines will soon be able to place their orders.

CZECHOSLOVAKIA

Claw-Type Loader

[The following is a translation of an excerpt from an article entitled "Klepetove nakladace," by St. P., in Uhli, Vol II, No 4, April 1960, Prague, pages 140 and 141; CSO: 4041-N/b]

The first series of the NK 25-E claw-type loader for mining was manufactured this year by the Frydlant nad Ostravici plant of the Transporta National Enterprise. The loader was designed by the Institute for the Mechanization of Mining. The loader can load coal mined in wall-type clearings and caves with unsecured ceilings; the loader is operated by a remote control electric device from a distance of 20 meters.

The model was also successfully tested in quarries and at construction sites. The remote control facilitates the loading of dusty and health endangering materials.

The new loader has a solid steel-cast frame, to which a shovel with its jib is secured by a swivel attachment. The shovel has a robust welded construction tested for easy penetration into the material for loading. A rake-type belt, drawn through the groove across the center of the shovel, collects the material that is passed by two pitcher claws made of scratch-resistant metal.

The electric engines of special construction have a cylindrical shape; in addition to the electric parts, they are equipped with planetary transmission chambers. Between the engines and driving gear are sliding clutches used in the event that the claws become wedged in. The shovel has two pegs on which it swivels. The jib has the shape of a chamber. The upper surface of the frame has a conveyor belt between its lateral walls. The front section of the jib is secured to the frame. It is lifted by its projecting rear part and by two hydraulic cylinders. The rear section of the job is connected with its front section by an upright peg. It revolves 30 degree in each left and right direction or in a range 3,600 millimeters wide.

The projection of the jib is controlled also by two hydraulic presses. The stretching of the conveyor belt is controlled from the rear end section of the jib. The conveyor belt has specially designed joints for horizontal and vertical bending.

In the rear-end of the frame under the jib is the electrically powered piston oil pump that distributes oil to all hydraulic cylinders. The oil conduit is protected against damage. The main frame houses the electrical equipment, the oil distributor, and the oil tank. The electric equipment is protected by shelters against explosion. All instruments are secured to sliding frames.

On the right side is a panel with buttons and switches for direct control of the machine. The frame has a sixteen-pole contact for remote control operation. The principal frame houses an eight-liter oil tank with an oil distributor for the hydraulic cylinders. The remote control device has a box with buttons in exactly the same arrangement as on the frame for direct control.

The loader moves on caterpillar belts equipped with steel-cast links and projecting parts to prevent the machine from sliding sideways. The operator is protected by fenders. The machine may be disassembled conveniently and quickly into several independent units. The transportation of the loader, even in mines, is therefore very easy. The output of the loader at full capacity is 120 tons per hour.

EAST GERMANY

Conference of Electrical Engineers

[The following is a translation of an article entitled "Zur Konferenz der Elektrotechniker," by W. Heinze, Chamber of Technology, Ilmenau, published in Nachrichtentechnik, Vol X, No 3, March 1960, Berlin, pages 93-94; CSO: 4124-N/1]

In the years since the founding of the GDR, the main attention in our economic policy had to be directed first of all to creating the necessary economic foundation in our raw material area in order to bring about the necessary output in the production of electric power; this was conditioned by the division of Germany and the development of two German states. After this task was successfully carried out, with the support of the Soviet Union and the countries of the socialist camp and the expansion of industrial production in the GDR thereby made possible--which today amounts to three-fold the production produced in the same territory in 1936, it was possible for the electrical industry to step forward and gain in economic significance.

Electricity has become an indispensable aid in driving and controlling machines in all branches of industry. Work processes earlier controlled by human beings are being automatically executed to an increasing degree by electrical equipment. Electronic machines are solving mathematical problems in a relatively short time and with greater dependability than man-solved methods. The basic technical and scientific idea, the technical execution, and the quality of electronic products determine to a decisive degree the high technical and scientific level of all branches of the economy.

A rigid steering of the economy and a favorable management of the constantly increasing trade is not possible without electrical communications engineering with technically highly developed products and constantly employable products. Therefore, electrical engineering is the "muscle and nerve system" for the industrial development of our economy, according to the words of Erich Apel, chief of the Economic Commission in the Politbuero of the Central Committee, at the Fifth Plenum of the Central Committee of the SED. Moreover,

the electrical industry has to make a definite contribution toward satisfying the growing material and cultural needs of our people. Thus the most modern, cheap electrical household equipment must be made available for lessening manual labor as well as for radio and television equipment with good receptive quality and absolute operational safety for our participation in cultural life. It is therefore planned in the Seven-Year Plan to increase the production of electric household equipment by 1961 to 230 percent and to produce 560,000 and 760,000 television receivers by 1961 and 1965 respectively as compared to the 180,000 produced in 1958. In the law concerning the Seven-Year Plan, the development in electrical engineering is to be given priority beside the developments in electric power, the chemical industry, and in certain production branches of machine-building. It is also required that the products in electrical engineering run ahead of those in other industries in regard to quality and amounts produced. The electrical industry carries a definite responsibility for the fulfillment of the main economic task, since only with its help can we reach the expected rapid mechanization and automation in all branches of industry in our republic. The electrical industry is therefore given the task of increasing production to 266 percent in the law on the Seven-Year Plan. As industrial production must be increased to 198 percent in the entire economy, the electrical industry must reach the highest rate of growth. The mighty tasks assigned to electrical enterprises are recognizable only when one considers that at the end of the third quarter of 1959 about 32 percent of all enterprises had not fulfilled their gross production and assortment plans. Many top economic assignments, such as the export program of the heavy machine-building industry, the power program, etc. were not fulfilled on schedule.

Besides the requirement for a quantitative increase in production and for better quality in the products produced, there are two points of view in the law concerning the Seven-Year Plan for the development of the national economy which are especially important for electrical engineering. First of all, there is the requirement for a steady decrease in costs, which is expressed in the fact that in the Seven-Year Plan as a whole labor productivity is to increase to 185 percent, whereas in electrical engineering the increase is to be to 270 percent. Secondly, the finished products are not only to meet the present world level but are to at least determine the world level in a number of important products.

The fact that in many enterprises the planned labor productivity was still not reached by exceeding the manpower plan, and high, extra-plan costs have led to the fact that the planned accumulation and production cost decrease have not been reached, indicates that we have not striven enough to improve the presently applied technology and for the development and introduction of new technological methods, and that standardization, as one of the most important means for increasing labor productivity, has still not been given sufficient attention by plant managers. The initiative of our workers, which is reflected among other things in 25,000 improvement suggestions which were submitted by the end of the third quarter of 1959, has not been utilized sufficiently by management organs so that the technology in enterprises could be decisively improved and thereby labor productivity increased. The significance of the electrical industry becomes clear when one reflects that precisely this industry has intensive wage systems and is able with its products to obtain high profits with a relatively small expenditure of materials. At the present time, electrical engineering products are especially suitable for export. These products, however, are suitable for export only when they meet the most modern technical standards. This fact requires our development engineers to do everything possible to eliminate the existing lag in some areas at the present time. Some of our coworkers active in the development area are still of the opinion that the real development is concluded with the creation of a satisfactorily operating prototype. This incorrect opinion cannot be energetically enough opposed. The goal of our industrial development must be to develop a product which can be rapidly produced. Therefore, the following investigation is essential to the successful conclusion of a development project: how the distribution of the assigned values of individual parts or also of the raw materials in construction elements will affect the quality and performance of products and with which technological method the smallest production costs can be obtained.

In regard to light-current engineering, the law of the Seven-Year Plan emphasizes especially the development of measuring, control, and regulation engineering, electronics, and semi-conductor engineering, whereby, besides transistors, ferrites, and miniature electric circuits made from semi-conductor materials, which are important for accounting and pulse engineering, are to be preferably developed and produced. Semi-conductor engineering is of special significance here, for the lag in this field has to a large degree obstructed the

entire apparatus development in light-current engineering, in regard to those apparatuses with which we compete on the world market.

A timely and logical removal of the existing disproportions in the electrical industry can be carried out only when, by clearly defining the responsibility of the individual, we succeed in making the over-all collective the foundation of management capability and realize the tasks before us through work associations and brigades. Socialist association work must concentrate on the solution of top assignments, whose fulfillment themselves come from the permanent production conferences of the union groups. Discussions are to be conducted in production conferences on measures which are necessary to ensure the optimal fulfillment of production plans. In these conferences, all shortcomings which hinder plan fulfillment must be uncovered and the discussions must be thorough, so that lags can be eliminated and workers oriented to new methods.

In the chemical industry, the discussions carried out with the widest number of work groups participating and the measures resulting from them were very successful so that Colleague Boehme, the chief of the electrical engineering sector of the State Planning Commission, proposed such a conference also for electrical engineering in the first quarter of 1960. The following problems will be treated at this conference as main topics of discussions:

1. Scientific and technical progress in the electrical industry
2. Measures for carrying out socialist reconstruction
3. The point of concentration of the electrical industry in the Seven-Year Plan
4. The responsibility of the electrical industry for increasing exports
5. The increase of profitability in the electrical industry
6. The support of the electrical industry by other branches of industry
7. The development and training qualifications of personnel for the electrical industry

Numerous specialists have already worked out for each topic themes in preliminary discussions and propose measures which will serve as the basis for the important discussions later and the measures plan resulting from these discussions.

In order to accelerate technical and scientific progress, socialist association work must be applied not only in all areas of research and development, standardization, technology, and production within enterprises but must also be expanded to all consumers, suppliers, scientific institutes, and university and technical schools.

The plans for the new technology must be reworked as part of the reconstruction plans after a careful comparison of the technical level with the world level in order to reach the highest level of technology in the electrical industry and as rapidly as possible.

The work circles of the research council and the scientific and technical centers of the "people-owned enterprises" have a decisive influence on solving the problem of making GDR products meet the world standards. Proper attention still has not been given to this important assignment. The Central Committee of the SED has not without purpose pointed up again and again the significance of scientific differences of opinion in regard to the problem of how further development in the technical and scientific area is to proceed. Further technical development is not taking place today as it did in the nineteenth century--i.e., erratically, on the basis of completely new knowledge--but rather continuously under consideration of the results of basic scientific research. The direction of technical progress can be viewed in a long-range aspect for a longer period of time, proceeding from necessities or requirements (not the demand). These types of long-range plans, which establish in what manner and in what stages technical and scientific development in individual industrial branches is to take place, must be worked out in the work circles and the scientific and technical centers and must be thoroughly discussed by including all specialists from enterprises and scientific committees. These plans not only make possible a control of the scheduled course of production but they also represent at the same time a valuable means of raising the scientific qualifications of our personnel. They are unconditionally necessary in the sharp subdividing of fields in electrical engineering and their connection with other branches of industry that allow the necessary development work with other branches of industry to be synchronized. The task of the scientific and technical centers in this sense is to clarify basic problems in cooperation with scientific institutes, the academy of sciences, and advanced schools and to coordinate measures which are necessary for carrying out the tasks.

A further important requirement is to shorten the development time for new products so that work is carried out simultaneously through the formation of work associations and not individually project after project. Here standardization, by which the multiplicity of new tools connected with the production process can be limited, is of great significance as this strongly delays the introduction of new products into production; experience has demonstrated this.

Standardization and typing is also, in addition to specialization and production concentration, extremely important for socialist reconstruction. Thus, for example, the production of standardized parts, say all tamped parts, could be concentrated in one enterprise within a branch of industry and thereby all experience in working out the best technology would be united in one enterprise. Only by such a concentration will the advantages which our socialist economic system offers be fully utilized. It is also possible, with the help of socialist association work, to create a uniform, similar technology for all enterprises from the technological methods which are frequently different in the many enterprises of one branch of industry, to create a technology which permits the optimum to be reached in regard to reduction of waste and manufacturing costs. Above and beyond this, the technical and organizational measures plan must be discussed and carried out more than heretofore as a part of socialist reconstruction.

The points of concentration in light-current engineering are in the construction elements, especially the already mentioned semi-conductors and ferrites, and also in contact parts and in tubes for the amplification and generation of microwaves. Besides satisfying requirements in enterprise measuring, control, and regulating engineering, those of commercial and wire-connected communications engineering for export are also of great significance.

We have already mentioned the significance of the electrical industry in meeting consumer goods requirements. We should also mention in this connection in regard to television receivers the production of picture tubes having a picture screen diagonal of 43 and 53 centimeters and 110 degrees deflection and, in regard to radio receivers, receivers with stereophonic reproduction.

The products of communications and measuring engineering and of electrical engineering consumer goods, in addition to

switching apparatuses and units belonging to light-current engineering, are especially suited for increasing exports. Therefore, the development of these products must be given greater attention than heretofore. Here many plant managers must revise their opinion that the production of measuring apparatuses is not profitable because they are not mass-produced, as are radio receivers.

The electrical industry is geared to a much greater degree than other branches of industry to the processing of qualitatively satisfactory special materials. In the past it has often had great misunderstandings with raw material suppliers in regard to its requirements. Under the "ton ideology" point of view, which judges the plan fulfillment of an enterprise only according to the amount and not according to the economic utilization of a semifinished product, the requirements of the electrical industry and especially the light-current engineering industry have been only spottily realized. Even if a certain alteration in this attitude has taken place under the force of circumstances, there is still considerable convincing work to be done as compared to the chemical industry and metallurgy until all justified requirements of the electrical industry have been fulfilled. All engineers and other responsible persons in the electrical industry hope that with the electrical conference a decisive alteration in opinions will be reached in regard to its relationship to the basic materials industry.

EAST GERMANY

The RVG 934 Radio Relay with Pulse Phase Modulation

[The following is a translation of excerpts from an article entitled "Richtfunkverbindungsgeraet mit Impuls-Phasen-Modulation RVG 934," by L. Janke, Chamber of Technology, Radeberg, published in Nachrichtentechnik, Vol X, No 3, March 1960, Berlin, pages 103-108; CSO: 4124-N/2]

1. Introduction

Radio relay equipment is being introduced to an increasing degree in the expansion and modernization of telephone networks. Radio relays with a pulse phase modulation are, above all, suitable in the lower network levels as well as in telephone networks of a larger undertaking--such as on railroads, in power supply plants, etc., in which only small speaking circuit bundles are necessary. The radio relay RVG 934, developed and tested in the VET RFT Rafena Plant, will be described in what follows. The construction of the equipment, its method of working, and its possibilities of application will be treated.

2. General Information on Pulse Modulation

The principle of pulse modulation is sufficiently well known from technical literature and it will be only briefly characterized here. For a distortion-free transfer of a telecommunications pulsation, it will suffice to temporarily scan this transfer in a periodic sequence. Only the scanned values need be transferred, whereby the scan frequency must be greater than the doubled value of the highest frequency to be transferred. Between any two pulses of a channel of this type, still other (n-1) pulses of further communications channels will be accommodated, whereby a transmission path for n channels is received.

In practice, the most used is the pulse-phase modulation (PPM) and the key action modulation of the ultra-high-frequency beam (AM); this is called the PPM-AM system. This method gives a good signal-to-noise ratio similar to FM. The type of modulation, moreover, places only small demands on

the ultra-high-frequency equipment. The amplitude and the length of the pulses used for the communications transmission is equal for all channels, as the modulation content is fixed in the temporary position of the pulse. Furthermore, the time distribution permits, in a simple manner, the branching of individual channels and relay points.

- 3. Principle of Communications Transmission with PPM

The process of telecommunications transmission with pulse phase modulation on a group of channels can be made clear in principle with the aid of Figure 1:

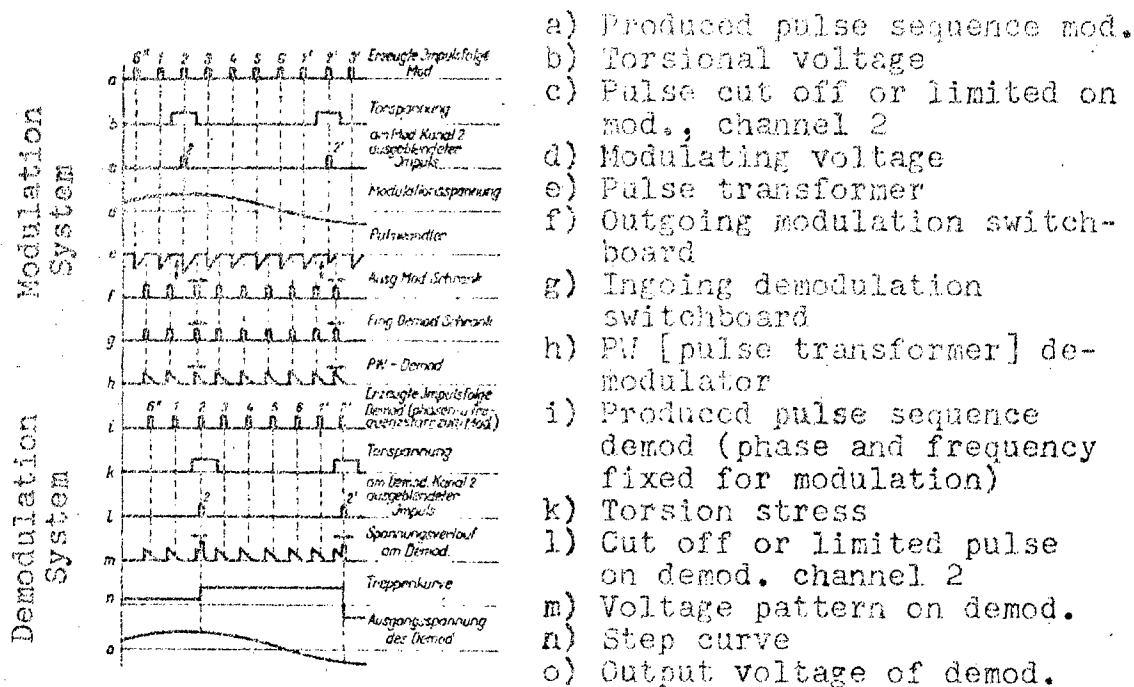

Figure 1. Principle of Communications Transmission with PPM

The pulse sequence a) is derived through known circuits from a quartz stabilized generator. The individual pulses of this sequence are distributed on the specific modulators of the individual channels of the multi-channel unit. This occurs, for example, in a specific circuit or switching arrangement through the auxiliary voltage b). The pulse sequence c), which is thus sorted out for each channel, is modulated in the modulator concerned with the communications voltage d). A series of saw-teeth e) is continuously modu-

lated in accordance with the instantaneous amplitude of the communications voltage of each channel. A sequence of pulses f) is derived from this continuously modulated saw-teeth series, whose position relative to an assigned pulse depends on the modulation voltage. The conversion of the continuously modulated saw-teeth series into phase modulated pulses is undertaken for a group of channels in common. The summation channel f) thus obtained and phase modulated is then conducted to the transmitter for transmission to the radio-range line.

On the receiver side, the pulse summation channel g), which is received and correspondingly formed and strengthened, is then switched onto the demodulation system. The individual pulses of the phase-modulated summation channel are converted into time-proportional voltage patterns (saw-teeth) h). In the demodulation part, a pulse sequence i) is produced which, through an assigned pulse, is held frequency- and phase-fixed with the received pulse summation channel. The distribution of the individual pulses of the produced pulse sequence to the modulators concerned takes place in the same manner as in the modulation system and is visible in lines k and l of Figure 1. In each channel the sorted out pulse sequence scans the corresponding saw-tooth m) and stores these patterns (which correspond fully to the patterns of the modulation side) in the demodulator to a so-called step curve n). The communications voltage is then again removed from the demodulator over a low pass [filter].

4. Technical Equipment Matters and Mode of Operation with the Aid of Connection Diagrams

We shall first of all observe a terminal point. The multiplex installations (modulation and demodulation system), as well as the ultra-high-frequency system, are accommodated in switchboards having dimensions of 1,540 x 600 x 222 millimeters (post construction type 52). In the multiplex equipment the individual equipment parts are subdivided into assemblies (Figure 2), which are assembled in easily exchangeable brackets (Einschuebe) (Figure 3). They are held fast with a locking mechanism after being inserted into the switchboard. The individually exchangeable panels into which the equipment is subdivided are screwed firmly in the ultra-high-frequency switchboard.

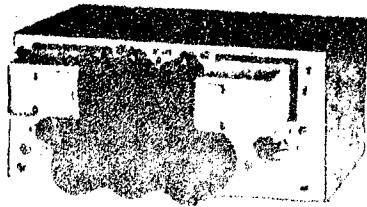

Figure 2. Demodulator
Assembly

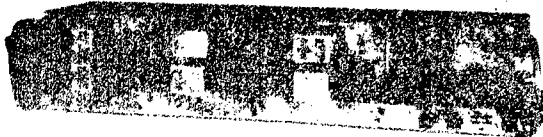

Figure 3. Modulator
Bracket

The brackets are connected over the spring contact strips with the panel cabling. Special cable connections are used for the ultra-high-frequency and pulse circuits.

The main supply power, as well as the connecting branches for the detached ventilators, are housed at the foot of the switchboard. Above in the switchboard are soldered distributors, and the connecting sockets for the communications of the equipment among each other are provided.

4.1 The Modulator Switchboard

The connection diagram in Figure 4 will illustrate the modus operandi of the modulation system. In frequency generation B, the voltages necessary for the distribution and generation of the pulses are derived from the fundamental frequency generated in base generator B₁. The 48-kilohertz-sine voltage obtained thereby through frequency multiplication is converted in the B₄ assemblies into the necessary four 48-kilohertz pulse sequences. Each channel is allotted a selected pulse sequence through a suitable combination of the generated torsional voltages with the four pulse sequences; this selected sequence is modulated in the B₅ modulators with the applied low-frequency and call signals. The low-frequency voltage is conducted to the modulators over low-pass filters in order to avoid undesired modulation products. The pulses modulated in the individual modulators of a group are separated in the common modulator terminal stage B₆, temporarily boxed in each other, with the output pulses of the other groups

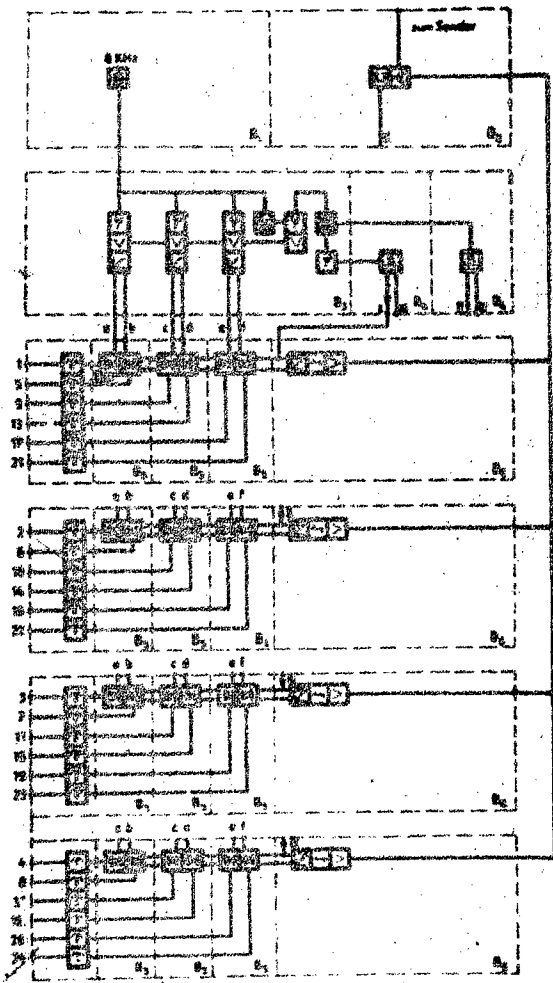

Figure 4. Connection Diagram of a Modulator Switchboard

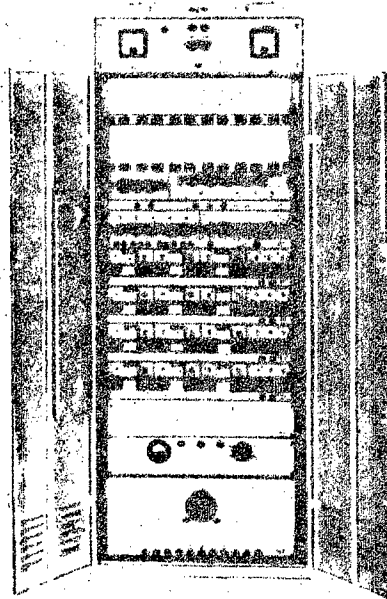

Figure 6. RVQ 934 Modulator Switchboard

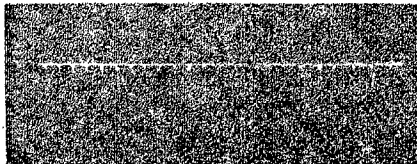

Figure 5. Pulse Summation Channel

as well as with the assigned impulse taken from the first channel and conducted over the assigned pulse stage; this assigned pulse is necessary for the synchronization of the called station. In this assembly B_6 , moreover, is located another switching arrangement for modulation limiting in order to avoid cross-talking through overloading. The pulse groups joined to the phase-modulated summation channel are brought to the output data required for the pulsing or key action modulation of the transmitter; this takes place in the pulse repeater B_2 (Figure 5).

The modulator switchboard (Figure 6) is constructed as follows, from top to bottom: the measuring field with connection field behind it; the low passes and the separation field; base generator B_1 ; pulse terminal repeater B_2 ; frequency generator B_3 ; pulse generator B_4 ; modulator groups B_5 and B_6 for each of the six channels, as well as the no-load field and the power supply unit.

4.2 Ultra-High-Frequency Switchboard

The modus operandi of the ultra-high-frequency system is illustrated in Figure 7. The pulse summation channel coming from the modulator switchboard (and/or on the relay point from the preceding receiver part) scans the modulator sender "high," which is stopped in the pulse interval by a negative bias voltage; this takes place over the modulation repeater. In order to lighten, and above all to define, the build-up of the transmitter, a so-called pilot transmitter (Lock-sender) is connected onto the modulation transmitter, which, by means of its amplitude, determines the starting of oscillations in the modulation transmitter. An improvement in the signal-to-noise ratio thereby results to the extent of about 3 N. A wave meter can be connected onto the transmitter for the control of the transmitting frequency. The transmitting power goes over a transmitting filter to the equipment outlet or output. The output power of the transmitter is indicated on an instrument and controlled by a special switching arrangement or circuit. Moreover, it is possible to oscillograph the transmitted pulse at the outlet.

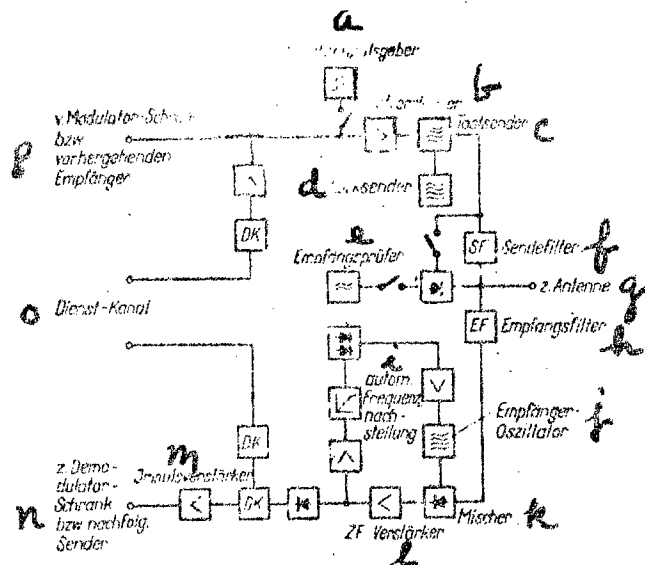

Figure 7. Connection Diagram of the UHF Switchboard RVG 934

- a) Spare pulse feeder
- b) Modulation repeater
- c) Modulation transmitter
- d) Pilot transmitter
- e) Reception tester
- f) Transmitter filter
- g) To the antenna
- h) Receiver filter
- i) Automatic frequency adjustment
- j) Receiver oscillator
- k) Mixer
- l) Intermediate frequency repeater
- m) Pulse repeater
- n) To demodulator switchboard or subsequent transmitter
- o) Service channel
- p) From modulator switchboard or preceding transmitter

The ultra-high-frequency power supply of the switchboard is connected over a cable with the antenna.

The signal received from the called station goes over the reception filter to the mixing circuit and is mixed with the frequency of the receiver oscillator. The thus

formed intermediate frequency is repeated in the intermediate frequency repeater and demodulated at the outlet. The summation pulse channel originates thereby is formed and repeated in the pulse repeater and is ready at the outlet of the receiver part for switching through to the demodulator switchboard (or at relay points for the transmitter in the other direction). The frequency of the receiver oscillator is automatically tuned into the frequency of the transmitter of the calling station with the help of a discriminator and a direction finder unit. An automatic volume control in the intermediate frequency repeater also provides for a constant pulse amplitude at the receiver outlet under oscillations of the inlet transmission level. The relative field strength received is indicated on an instrument in the measuring field of the switchboard. A reception tester makes possible the examination of the receiving unit with the aid of its own transmitter. This testing is provided for automatically over the internal control (see section 5) before each cut-over to the eliminators.

The ultra-high-frequency switchboard is an outarch by reason of a service channel pulse unit, so that it is possible to operate and assure the speaking connection between two ultra-high-frequency switchboards through the automatic switching in of a spare pulse feeder from the outside in the case of a lacking pulse summation channel.

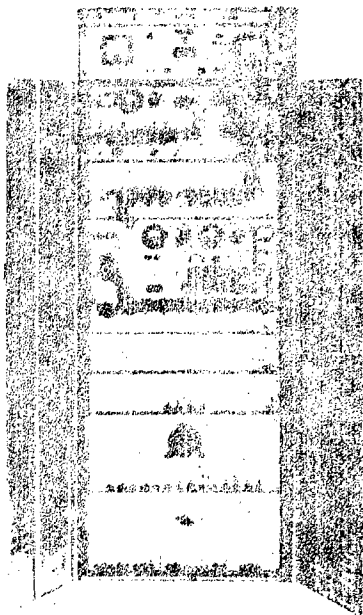

The UHF switchboard (Figure 8) consists of a UHF measuring field and the internal control, the transmitter, the switch and reception tester, the receiver, the service channel unit, and the power supply units.

Figure 8. RVG 934 Ultra-High-Frequency Switchboard

4.3 The Demodulator Switchboard

The connection diagram in Figure 9 clarifies the modus operandi. The phase-modulated summation channel received from the called station is conducted from the receiver part to the demodulation system. It reaches the synchronizing generator B7 and the pulse converter B8. In the pulse converter the incoming summation channel is divided into even-numbered channels B and odd-numbered channels A. The phase-modulated pulse groups A and B are converted into conversion stages in phase-modulated saw-teeth series. Two demodulator groups contain at any given time one of this type of saw-tooth series.

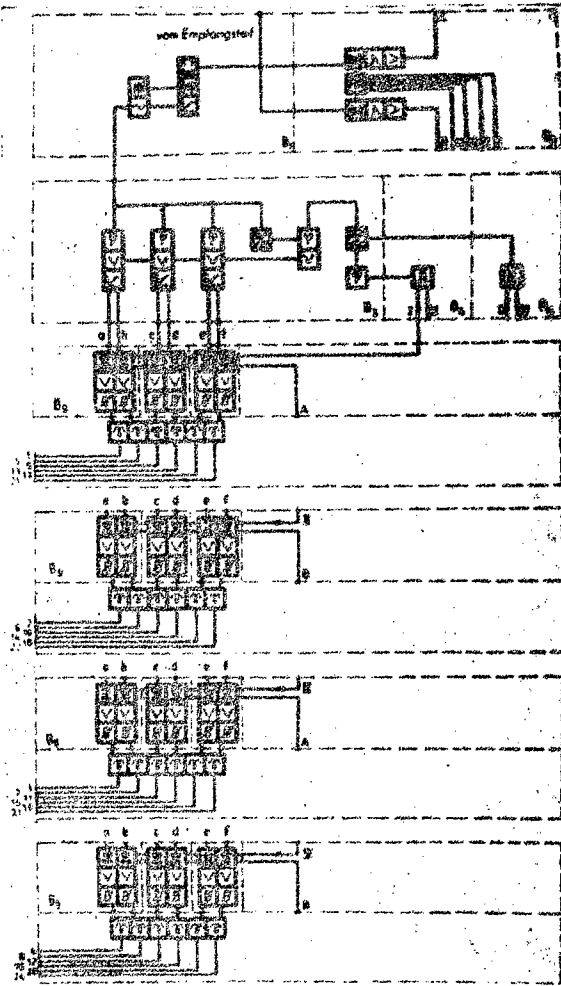

Figure 9. Demodulator Switchboard Connecting Diagram

fundamental frequency in the assemblies B₃ and B₄, as in the modulation system.

The pulses distributed to the individual channels, as in the modulation system, are compared in demodulator B with the temporally corresponding sawteeth. The communication thus modulated on is again removed thereby from the channel.

The construction of the demodulation switchboard is shown in Figure 10 [caption: RVG 93⁴ Demodulator Switchboard]. It consists of the measuring field with a connection field behind it, the low-passes, and the separation field, the synchronizing generator B₇, pulse converter B₈, frequency generation B₃, pulse generation B₄, four demodulator groups B₉ for each of the six channels, the no-load field, and the power supply units.

4.4 Control Oscillograph

The control oscillograph RVG 93⁴.1800 is used (Figure 11 [not reproduced]) for the operational adjustment and control of the PPM unit. Combined in it is a specially developed visual indicator for controlling the pulse summation channel with a standard oscillograph as a repair measuring device and for the adjustment of the UHF transmitter.

5. Application Possibilities of the RVG 93⁴

5.1 General

The RVG 93⁴ radio relay apparatus permits the transmission of up to 22 telephone channels, wireless, in the frequency range of 2,450 to 2,700 megahertz by the method of pulse-phase-modulation. The technical conditions of the apparatus are laid out so that the requirements of the CCIF for long-distance circuits are adhered to. For this, the sound values of the multiplex apparatus may not fall below a certain value and the so-called system value, which the quality of the ultra-high-frequency system characterizes must also not fall below a prescribed value. The diagram in Figure 12 shows the connection between signal-to-noise ratio and radio field transmission loss. The signal-to-noise ratio consists of two components:

- a) that which is independent of the radio field transmission loss;
- b) that which is dependent on the radio field transmission loss.

The latter results from the relationship:

$$b_{StF} = S - b_F [N]$$

whereby the system value S is given by means of:

$$S = p_S + v_S + v_E - p_R [N]$$

where p_S = transmission level

v_S = transmitting gain

v_E = reception gain

p_R = fundamental background noise

b_P = radio field transmission loss

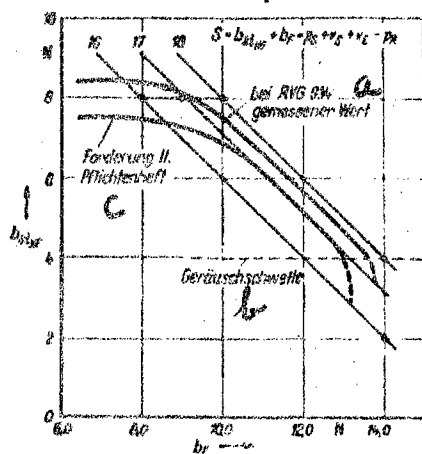

Figure 12. Signal-to-Noise Ratio Depending on the Radio Field Transmission Loss

- a) at the RVG 934 measured value
- b) noise threshold
- c) requirement [?] rating

The curve indicated in Figure 12 runs at a small radio field transmission loss parallel to the abscissa and is determined by the background, which is independent of the radio field transmission loss--for example, by the noise of the multiplex apparatus and the transmitter. After a transmittal, it flows into the system value line in order to deflect parallel to the ordinate at the noise threshold. The requirements according to the ratings and the values measured on the RVG 934 apparatus are carried into the diagram.

Figure 13 illustrates the level or volume plan of a radio field, which will be treated briefly in what follows. The low-frequency input level amounts to -2 N. The transmitter is modulated with pulse sequences for which the communication was modulated on in the modulation switchboard. The mean transmission level is recorded by p_S . Through high modulation a transmission gain of v_S is received, which in the usual systems amounts to about 1.4 N. There follows the radio field b_P , which is made up of the free space transmission loss b_S , the cable transmission losses b_K on the

transmitting and receiving side, as well as the gain of the transmitting and receiving antennas b_A . The reception gain v_E is dependent on the modulation process and amounts to about 1.6 N in the case of the data advanced. The low-frequency output level of the multiplex apparatus is transmitted from +1 N after the repeating process and the modulation conversion.

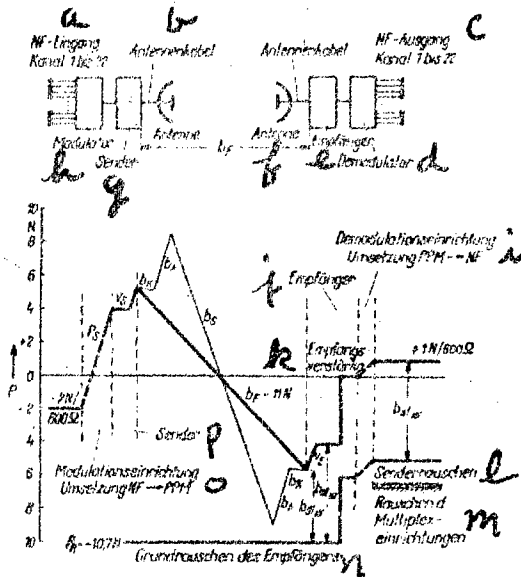

Figure 13. Level or Volume Plan of a Radio Field

- a) Low-frequency input, channels 1 to 22
- b) Antenna cable
- c) Low-frequency output, channels 1 to 22
- d) Demodulator
- e) Receiver
- f) Antenna
- g) Transmitter
- h) Modulator
- i) Demodulation system, conversions PPM \rightarrow NF
- j) Receiver
- k) Reception repeater
- l) Transmitter noise
- m) Noise of the multiplex system
- n) Fundamental background noise of the receiver
- o) Modulation system, conversion NF into PPM
- p) Transmitter

The signal-to-noise ratio $b_{st_{NF}}$ results as the difference in the output level and the available noise level or volume. It is evident that the noise of the multiplex

apparatus and the transmitter or the noise which depends on the radio field transmission loss is determinative, each according to the size of the radio field transmission loss.

5.2 Radio Relay with RVG 934

A radio relay consists in its simplest form of two terminal points. The multiplex apparatus (i.e., modulator and demodulator switchboard) and a UHF switchboard belong to one terminal point (Figure 14).

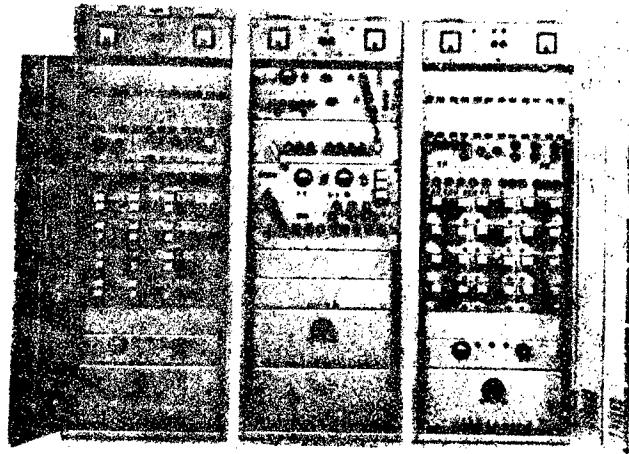

Relay points are contacted in accordance with the given topographical conditions between the terminal points for the purpose of bridging over greater distances. The length of the radio fields thus resulting are to

Figure 14. RVG 934 Terminal Point

amount to 45 kilometers as a rule; conditions for this are optical sight and freedom from obstacles in the first Fresnel zone. In the simplest case, a relay point consists of two UHF switchboards in which the pulse summation channel is switched through specifically from the receiver of the one switchboard to the transmitter of the other UHF switchboard (Figure 15).

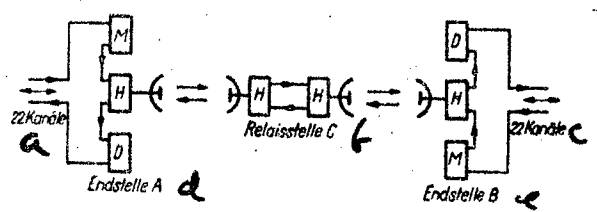

Figure 15 Radio Communication with Relay Points

- a) 22 channels
- b) Relay point C
- c) 22 channels
- d) Terminal point A
- e) Terminal point B
- M) Modulator switchboard
- D) Demodulator switchboard
- H) UHF switchboard

The 22 channels are conducted to the multiplex apparatus by four wires in the low-frequency position. Suitable forked supports can be used if a two-wire connection is desired. For transmitting calls, selective signals, and direct-current telegraphy, the transmitting and receiving relays available for this in the multiplex apparatus are used over separated circuits. Call translators (25 to 50 Hertz call frequency in alternating current calling) are used according to the system applied.

The second channel is used as a service channel for direct telephonic communication of the individual terminal and relay points among each other. The supplementary switchboard with the general purpose service channel DK 981 can also be used for this as servicing equipment. It makes possible a selective calling and speaking up to 27 participants. The first channel serves for the transmission of synchronizing signals between the terminal points.

The equivalent circuit possibility of the UHF switchboard exists at both the terminal points and the relay points. A so-called internal control (EUE [Eigeneuberwachung]) is built into each UHF switchboard, which, in the application of a UHF antenna switch, makes it possible to change over to an available UHF reserve switchboard in case one UHF switchboard breaks down. A station equivalent circuit is used at relay points--i.e., the entire relay point is switched over. The internal control unit tests automatically before each switchover to the reserve switchboards whether the indicated disturbance is caused by a defect in its own apparatus or by the failure of the signal from the calling station. Faulty switchovers are thereby avoided.

Dipole parabolic antennas with a mirror 1.5 or 2.5 meters in diameter are used as antennas. These are connected over UHF cables with the UHF switchboards. Deflecting mirrors are used preferably if greater antenna heights are required. Here, for example, the parabola mirror is built on the roof of the station building and the beam is conducted over a deflecting mirror mounted on the antenna pole.

5.3 Radio Relay with Shunting or Branching

In using the shunting switchboard RVG 934.3000, the possibility exists of taking out up to 11 channels by low-frequency from the pulse summation channel switched through to the

relay points and inserting in the place of the channel pulses concerned, which were demodulated and discharged up to 11 new communication channels (i.e., pulses). The switchboard can be constructed so that the most diverse variations of the shunting technique are possible with it. Figure 16 shows an example of the scheme of such a radio relay with shunting point. From terminal point A, 22 channels go to the shunting point, eight channels end there in low frequency, and eight new channels are inserted in place of the cut-off eight channel pulses. Thus 22 channels run further on to terminal point B. Thus the following connection exists:

Terminal point A with terminal point B	14 channels
Terminal point A with shunting point	8 channels
Terminal point B with shunting point	8 channels

The shunting switchboard is composed of up to 90 percent of the assemblies found in the RVG 934 multiplex apparatus.

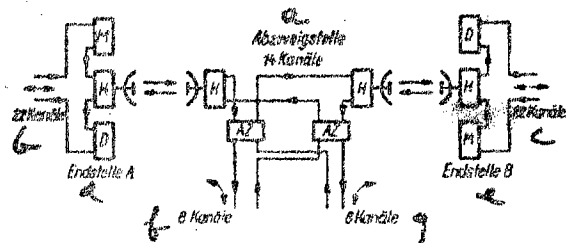

Figure 16
Radio Relay with Shunting Point

- | | |
|--------------------------------|----------------------------|
| a) Shunting point, 14 channels | M) Modulator switchboard |
| b) 22 channels | D) Demodulator switchboard |
| c) 22 channels | H) UHF switchboard |
| d) Terminal point A | AZ) Shunting switchboard |
| e) Terminal point B | |
| f) 8 channels | |
| g) 8 channels | |

5.4 Radio Relay with Disconnecting or Separation Point

With the installation of the disconnecting switchboard RVG 934.4000, the possibility exists at one disconnecting point of branching by pulse a pulse summation channel coming from one direction into different directions. The pulse sequences coming from these directions are combined again into one direction in the disconnecting or separation switchboard. Through switching can also be done within the individual directions. In order to box the individual pulses within each other at the disconnecting or separation point

in the proper phase relation, all terminal points operating in a network of this type are synchronized by the disconnecting point. All terminal points are equipped with pulse timing equalization. There is also the possibility of expanding this apparatus for the most diverse requirements. An example of the radio network with disconnecting point is shown in Figure 17, in which a disconnecting point with three directions is given for the sake of simple description.

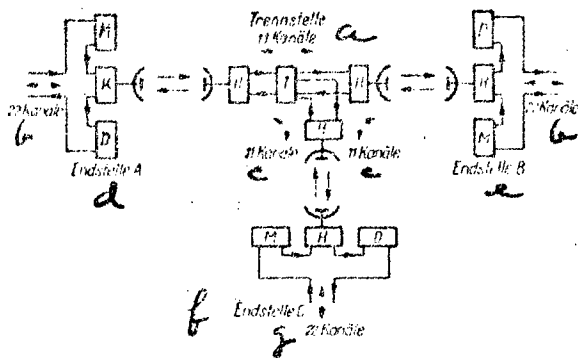

Figure 17
Radio Relay with
Shunting Point

- | | |
|-------------------------------------|----------------------------|
| a) Disconnecting point; 11 channels | M) Modulator switchboard |
| b) 22 channels | D) Demodulator switchboard |
| c) 11 channels | H) UHF switchboard |
| d) Terminal point A | T) Disconnecting switch |
| e) Terminal point B | |
| f) Terminal point C | |
| g) 22 channels | |

From terminal point A, 22 channels are transmitted up to the disconnecting point. There they are disconnected by pulse, and each of 11 channels proceed to terminal points B and C can be fully utilized, when an additional 11 channels over the disconnecting point are switched from terminal point B to terminal point C. The following connection thus exists in the network from Figure 17:

Terminal point A with terminal point B	11 channels
Terminal point A with terminal point C	11 channels
Terminal point B with terminal point C	11 channels

With the described apparatus, the PPM units can be used in large undertakings for the communications networks and do justice thereby to all possible variants of network planning.

6. Technical Data of the RVG 934

6.1 Multiplex Systems

Pulse width	0.5 μ S
Pulse interval	5.2 μ S
Assigned pulse width	2.5 μ S
Maximum pulse percentage modulation	1.5 μ S (about)
Channel count	22 channels
LF transmission range	300 to 3,400 Hertz
Apparent input and output impedance	600 ohms

The permissible error of the series switching from the input and output apparent impedance measured against 1,200 ohms shall be < 15 percent.

LF input level or volume
LF output level or volume

- 2 N
+ 1 N

The output level is controllable in four stages to 0.1 N for each.

LF amplitude phase

The over-all transmission loss tolerance cheme indicated by the CCIF is taken as a basis

Distortion factor
Call transmission

< 5 percent
Direct current call,
capable of selection

Signal-to-noise ratio (in combined switching of the modulation and demodulation units)

\geq 7.65 N

6.2 UHF System

Frequency range
Channel count
Channel interval
Transmitter output (temporary mean value)

2,450 to 2,700 megahertz
20 UHF channels
12.5 megahertz

> 2 watts

Frequency stability of transmitter	5×10^{-4}
Type of modulation	Pulse modulation
Receiver oscillator with automatic direction finder unit:	
System value	> 17 N
Intermediate frequency	≈ 35 megahertz
LF band width	8 megahertz
Antenna--dipola parabola mirror:	
Opening diameter	1.5 meters 2.5 meters
Aerial amplification	3.1 N 3.6 N
Characteristic impedance	60 ohms
Power supply voltage	220 V ± 2% 50 Hertz
Rage of power input:	
Modulator switchboard	0.4 kilovolt amperes
Demodulator switchboard	0.5 kilovolt amperes
UHF switchboard	0.3 kilovolt amperes
Dimensions:	
Post construction type 52	About 1,540 x 600 x 222 millimeters

EAST GERMANY

New Products of the VVB Communications and
Measuring Engineering

[The following is a translation of an article entitled "Neuheiten der VVB Nachrichten- und Messtechnik auf der Leipziger Fruehjahrsmesse 1960," by Bartholomaei/Epp, published in Nachrichtentechnik, Vol X, No 3, March 1960, Berlin, pages 131-134; CSO: 4124-N/4]

The great tasks which the Seven-Year Plan of our republic has assigned to electrical engineering are reflected in an abundance of new developments of our people-owned industry at the Leipzig Spring Fair, 1960. New production methods will be introduced to an ever greater degree and standardization and automation measures will be introduced which will contribute to the necessary further increase in labor productivity.

The enterprises of the VVB Communications and Measuring Engineering, whose products have for years brought about good export contracts, are exhibiting a large number of new developments at the Leipzig 1960 Spring Fair, of which the most important will be indicated in the following brief report. All enterprises of this VVB are showing their exhibits this year for the first time in an impressive collective exhibit in the south nave of Hall 18. A cleverly executed architectonic design by the architect Haenel of Berlin gives the right wing of the south nave its distinctive characteristics.

The wire-connected electrical engineering group is accommodated in the front part. There the cooperation of the individual communications apparatuses and installations, from the table telephone apparatus and telegraph teletype over the exchange and transmission systems up to the called station are sensibly demonstrated. On exhibit are the successful apparatuses of the people-owned telecommunications plants in Arnstadt, Leipzig, Bautzen, and Nordhausen; the Karl-Marx Stadt VEB Apparatus Plant; and the Koelleda VEB Radio Plant. The products of these plants have already met with the good approval of the 1959 Fair visitors.

Commercial radio engineering is represented on the inner front side in three stories of the imposing construction which is built in the form of the command bridge of an ocean steamer.

The VEB Radio Plant in Koeppenick is exhibiting as a new-development several apparatuses in ship radio and navigational engineering; to these belongs an air-cooled gyro compass unit for measuring, transmitting, and indicating the course of ocean-going ships. This unit differs from water-cooled units in its simple construction, small weight, and small volume.

A modern navigational system is the automatic control unit for ocean-going ships, which makes possible an automatic maintenance of the planned course.

The improved ship radar unit FGS 350 (KSA 5) (Figure 1) is planned as a navigation aid for installation on the main-

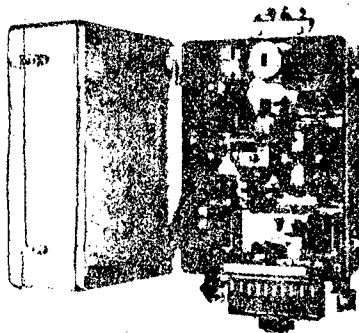

Figure 1
Ships' Radar KSA 5

land and on ocean-going ships. It is especially suitable for small ship units or on larger ships as an automatic two-part unit (Zweitanlage) by virtue of its extremely small and light design. It satisfies the requirements in navigating coastal waters, narrow channels, heavily traveled shipping routes, and under weather conditions of poor visibility and ice. A map-like picture of the environs of the ship is produced on the picture screen of the sighting apparatus, from which the direction and distance of obstacles can be determined. The location of its own ship is identical with the center of the screen picture.

The following individual parts belong to the complete ship radar unit FGS 350:

1. Beam aerial A 5, 20 revolutions per minute, with an ensuring beam or directive antenna effect of 2 degrees horizontal and 20 degrees vertical half widths, minor secondary beam transmission loss of > 30 dB [decibels?].

2. Transmitter and receiver apparatus G 5 with socket power unit. The transmitting part is equipped with a 2 J 42 magnetron and operates at a frequency of 9,375 mega-

hertz (3.2 centimeters). The pulse sequence frequency of the pulse modulation amounts to 1,600 Hertz, pulse duration 0.13 μ S (up to 1.5 sm [meters per second?]), and 0.5 μ S (starting with 3 sm), pulse output 7 kilowatts. The reflex klystron 723 A/B as an oscillator tube for the receiving part and an OA 513 as a mixed crystal were installed. The sensitivity of the reception part is given as 25 k T_0 ; low frequency = 35 megahertz.

3. A junction box for the G 5.

4. Sighting apparatus H 5 with socket power unit. Picture diameter 9". The special advantages of this part are: zero point expansion, premarking (Vorausmarke), distance measurement, course interference, minimum sharpening of precipitation, hand regulation of the reflector spanning.

5. Junction box for the H 5 and 6. Power supply.

The FGS 350 is designed drip-proof, with the exception of the antenna, and is planned for assembly in closed spaces. The temperature range is 0 to 55 degrees centigrade. The antenna operates satisfactorily at every degree of humidity and precipitation and under ambient temperatures of -30 to +70 degrees centigrade.

The controllable pitch propellor manufactured by Koepnick operates on a hydraulic basis and makes possible full engine performance utilization under various resistance circumstances--for example, freeing, dragging or towing, ballasting, etc.

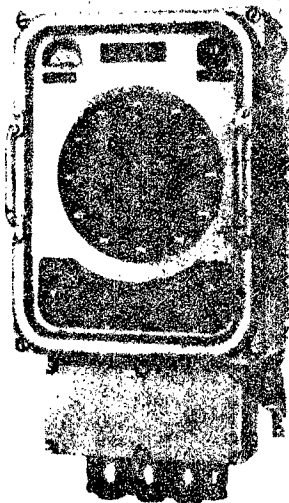

Ship safety is significantly increased through of the H A 6 sonic depth finder (Figure 2), which has a small volume, high sensitivity, and improved indication. This unit permits a running optical indication of the water depth below the keel. Two measuring ranges from 0 to 120 meters and 0 to 1,200 meters are provided for navigation over waters having medium and great depths. The following apparatuses belong to the complete unit: indicator

Figure 2.

The H A 6 Sonic Depth Finder

apparatus, amplifier, power generator, transmitting oscillator, receiving oscillator, and junction box with plugs, which are connected with each other by a cable system. The indicator apparatus is equipped for wall hanging but can also be set up on a desk. A large circular scale, equipped as flood light scale, makes reading easier. Its brightness is selectively adjustable. The over-all simplification of the unit amounts to ≥ 122 dB. Each arriving echo is directly indicated by a new type of indicator. Pre-echoes caused by schools of fish between the bottom line and the water line are also visible as a weak indication. It is possible to mask them with the amplifier regulator. The previously successful products for ship-building are also being exhibited, besides the above-mentioned products, to complement the assortment.

In Hall 15 the Leipzig VEB Apparatus Plant is exhibiting a "Pulsadis" audio-frequency circular control relay constructed under license by the French firm CdC [not identified], which, in cooperation with the transmitting units produced by this firm, undertakes, among other things, the control of power consumption in exact accommodation to the ratio of load available at any given time.

Also in Hall 15, a modern band control unit from the VEB Communications Apparatus Plant in Dresden is being exhibited. This type of unit, adaptable to any production method, is being built in an ever-increasing degree within the framework of the necessary rationalization measures being carried out in industry. The control and monitoring organs of the unit are put together according to the prefabricated parts system and thereby permit easy exchangeability as well as expansion of these units under altered assignments.

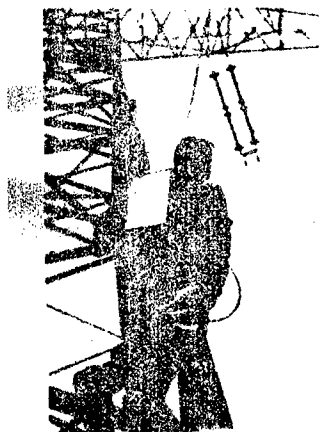

Only tested assemblies from communications engineering are being applied, which are operationally sure. The control unit guarantees that all necessary switching processes are started, disconnected, monitored, and also--in particular cases--made to reverse themselves, all from one switchboard. The luminous circuit diagram used gives an exact survey of the operational situation at any time, much the same as a dispatcher.

The units can be adapted to any production process individually and make possible

Figure 3. Ultra-High-Frequency Radio-telephone in Operation

the control and monitoring of industrial installations in all branches of our economy.

The new portable ultra-short-wave radiotelephony apparatus with transverter-power supply from the VEB Radio Plant in Dresden (Figure 3) should be especially examined. This set operates by the zero phase angle modulation principle. It makes possible radio conversation with similar portable or other mobile and stationary radiotelephone stations. The transmitting and receiving apparatuses and the power supply are housed in separate cases in order to do justice to the given demands by carrying the two divided apparatuses in a different manner.

The two FBA 1 and FBA 2 remote observation units of the VEB Plant for Telecommunications are valuable aids in the remote observation of the most diverse scientific and industrial processes. The new FBA 2 has been especially developed for rough operation. All appertaining apparatuses are built into spray- and floodwater-resistant aluminum cases, which are equipped with air filter sets and air filters for ventilation of the apparatus itself. Outside ventilation with compressed air is also possible under specially difficult conditions. We must mention especially the automatic diaphragm setting of the long-distance camera in agreement with local light conditions. Diaphragm and range setting are also possible in the remote control field. The camera operating apparatus is also set up for a carrier as well as a video frequency transmission.

A valuable addition to television engineering is the newly developed television studio camera FSTK 1-1.

The gaps in apparatuses in the field of electro-acoustics which originated last year are now being closed through the improved reciprocal loudspeaking units of the VEB Radio Plant in Koelleda. Exhibited by this enterprise are: the WELTON Roentgen-reciprocal loudspeaking unit WL 3 (Figure 4), which consists of a main speaking point, an amplifier, and one to three auxiliary speaking points, in whose place call loudspeakers or passive auxiliary points--for example, door speakers--can be connected

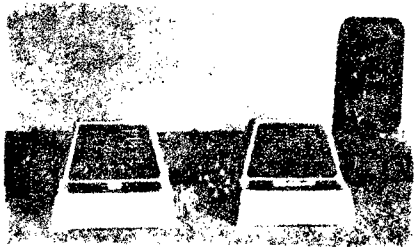

Figure 4

Reciprocal Loudspeaking Unit

7
The speaker units are accommodated in colored plastic cases, and the amplifier--electro-acoustic response one watt, distortion factor 4 percent--is built into a wall case. Maximum distance between the speaker points, 200 meters.

Besides the usual loudspeaking traffic, the shunting reciprocal loudspeaking unit WELTON WAR 10 makes it possible to speak over power amplifiers and loudspeaker groups. This unit permits a maximum of 20 call stations.

In addition, the Koelleda Radio Plant is exhibiting small and medium sized reciprocal units for industry and institutes.

An especially large share of the fair exhibitors have their electric measuring and testing equipment within the radio engineering sector, which equipment is to be thoroughly standardized.

VEB Telecommunications Plant, Leipzig: The calibration level generator GU 601 serves as a standard alternating current voltage source for the calibration of transmission level meters in the low frequency and TF [not identified] area. The level (+ 1 to - 5 N in neper stages, accuracy + 0.005 N) is thoroughly independent of oscillations of the operational voltage, temperature, and size of the output load by virtue of suitable stabilization measures.

We shall also mention the Sh 701 high-pass and St 702 low-pass.

The following new apparatuses were developed in the VEB Radio Plant in Koepenick for pulse engineering:

The double-pulse generator IS 2-5 (Figure 5) for the balancing of two or--with the use mixer inputs--more reflection signals, step signals, or for the formation of pulse groups, etc. In connection with an oscillograph, sinus-voltages and masking effects on amplifiers and meter system can be analyzed. These are preferably planned for use in tubular conductor-assembly development.

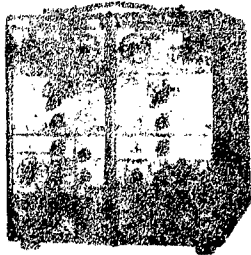

Figure 5

Double-Pulse Generator

The DT 1-5 pulse delayer (Figure 6) is a modern measuring apparatus for the defined delay of pulses in the range of $0.1 \mu\text{s}$ up to 1.0 s , which, after the expiration of this time, supplies a needle pulse, and with delay periods of $\geq 1 \mu\text{s}$ a rectangular pulse of alterable width.

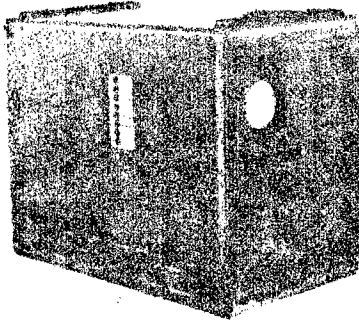

Figure 6
Pulse Delayer DT 1-5

With the pulse oscillograph OG 1-10 (Figure 7) an apparatus is made available for the representation of pulse-like and periodic processes in the time range between nonaseconds and seconds. The pulse generator IS 1-8 (Figure 8) supplies extremely short rectangular pulses

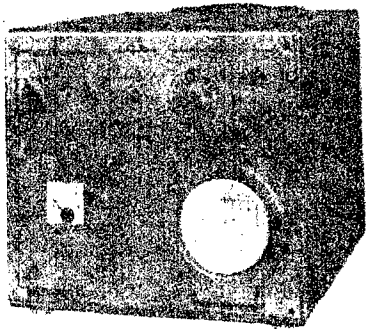

Figure 7
OG 1-10 Pulse Oscillograph

in the range of 20 nonaseconds up to $1.1 \mu\text{s}$, with a sequence frequency of 10 Hertz to 200 kilohertz. The output amplitude of the pulses are adjustable in regard to positive and negative separation. The possibilities for use are in the development of construction elements and in four-pole circuit investigations.

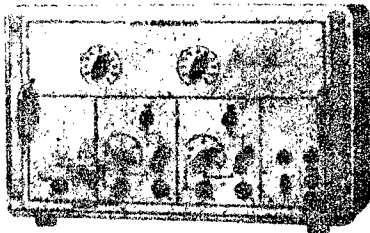

Figure 8
IS 1-8 Pulse Generator

The centimeter-signal generator SS-10 (Figure 9) is preferably suitable for development and testing assignments on radar units and radio-range lines in the X-band (3 centimeters) and for instruction and training purposes.

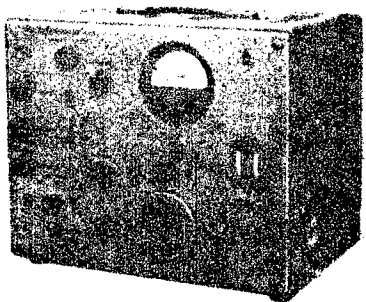

Figure 9
Centimeter-Signal Generator SS-10

The clear-out or releasing generator TS 1-8 (Figure 10) serves for control of apparatus switchings in pulse engineering which do not have their own releases. Its pulse sequence can be adjusted from about 5 μ s to 100 ms within 11 ranges.

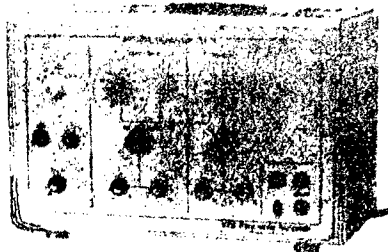

Figure 10
Releasing Generator TS 1-8

The rectangle generator RS 1-8 (Figure 11) is being put on the market for the investigation of active and passive four-pole circuits and for the measurement, release, and control of electronic processes in pulse engineering. The pulse duration is 1 μ s to 1 ms; the releasing sequence--external--is between ∞ and 10 μ s, corresponding to 0 to 100 kilohertz. The rectangle generator can also be applied as a pulse generator with a pulse width of 200 nanoseconds.

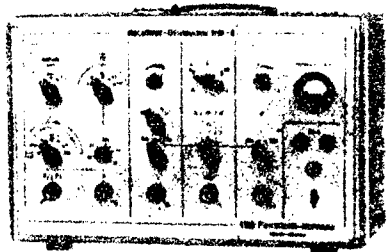

Figure 11
Rectangle Generator
RS 1-8

The broad-band amplifier BV-9 (Figure 12) is a measuring apparatus for the amplification of periodic and aperiodic alternating-current voltage in the frequency range of one Hertz up to 30 megahertz. It is characterized by its highly resistive input, an amplification regulation independent of frequency, a comparison voltage feeder for amplitude measurement, electronically regulated socket power unit, symmetrical output, and connection for key head for low capacity measurements.

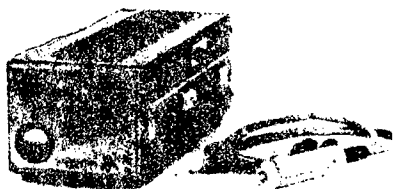

Figure 12
Broad-Band Amplifier
BV-9

The frequency multiplier VS 1-5 (Figure 13) supplies several high-frequency voltages of determined frequencies and amplitudes (5 megahertz up to 200 megahertz), which are a multiple of a quartz-controlled fundamental frequency of one megahertz. It can be utilized as a frequency and time

standard in the entire measuring engineering by means of extracting a one-megahertz synchronization voltage and controlling an external one-megahertz voltage.

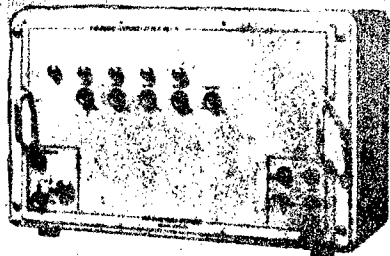

Figure 13
Frequency Multiplier VS 1-5

Two transistor testing apparatuses for use in testing fields, laboratories, input controls, etc. for orienting and rapid measurement of transistors and germanium diodes are among the new exhibits of the VEB Radio Plant in Erfurt. The tests of the transmission and the blocking behavior in germanium diodes in both apparatus types--1019 and 1020--have proved satisfactory. In transistors, the residual commutator current and the short-circuit current amplification or large signal amplification are measured in the emitter switching.

A further development of type 219a is the inductivity measuring bridge type 1012, which meets the requirements of laboratory and testing field. The measuring range is 0.001 to 122.2 H at measuring frequencies of 80.8 and 8,000 Hertz.

The television modulation booster type 7005 is set for use in production enterprises in combination with the ultra-high-frequency measuring generator for testing and monitoring television apparatuses. The carrier-frequency range is 20 to 240 megahertz, the input voltage ≤ 50 megavolts, the modulation frequency range 5 Hertz to 8 megahertz, the range below the point where overload begins of the output voltage is 10 to 100 percent, the rate of climb < 50 nonaseconds, the top incline (Dachsschraege) at 50 Hertz = 2 percent.

The high-frequency measuring generator type 159 has undergone design and technological improvements and is now exhibited as type 2159. This concerns the changeover to miniature tubes, the use of a drum linear scale for better reading of the frequency range, and improvement of the high-frequency degree of distortion and the modulation distortion factor.

The straight-circuit meter type 3501 is especially suitable where mechanical meters can no longer be used because of their slowness. It serves for the recording of pieces, revolutions, error oscillations, piston strokes, etc. A built-in start and stop device permits the introduction and ending of the recording process by hand or by control pulses from outside. The recording speed is 0 to 100 kilohertz, the spot persistence about 5 μ s.

The ultrasonic material testing apparatus type 902⁴ contains connection possibilities for several newly developed supplementary apparatuses. The interferometer type 902³ serves to determine the velocity of sound and the signal transmitter (monitor) type 9022 serves as an auxiliary unit in the nondestructive testing of the mass of machining or tooling blanks of all types.

The direct indicating $\tan \delta$ -meter type 1018 permits a direct reading of the loss factor and is advantageous for the testing of small condensers or insulation material. Trained personnel can reach a high classifying speed in a short time through a simple operation. The capacity range is 1,000 to 10,000 pF and 100 kilohertz.

The small sound intensity meter TSM 2 is to be recommended for the objective measurement of medium and high sound intensities in the range from 60 to 125 DIN decibels and 30 to 12,500 Hertz; this meter is produced by the VEB Plant for Telecommunications. The small handy apparatus operates by battery.

The field intensity meter FSM 201 measures field intensities of unmodulated, pulse modulated, and AM and FM modulated transmitters in the frequency range of 200 to 100 megahertz. The apparatus consists of receivers, a dipole broad band antenna with four adapter units, and a power-supply unit. The field intensity range comprises 0.5 μ V/m up to 2,000 mV/m and is subdivided eight times. The band width amounts to 150 kilohertz for the 10 megahertz intermediate frequency and is 10 kilohertz for the second intermediate frequency of 10 megahertz. The voltage measurement range linearly is 0.2 μ V to 3 mV, logarithmic 0.7 μ V to 100 mV. The input resistance of the receiver is 70 ohms.

The field intensity meter FSM 3 measures electromagnetic fields in the range of 87 to 300 megahertz.

The rectangular wave testing generator RWG 4 serves the purpose of testing broad band fields in connection with a cathode ray oscillograph. The apparatus is also suitable for the generation of a beam pattern on the picture screen of RV receivers for testing the linearity of the deflection systems, reflections, and the spot persistence. The frequency range is 50 Hertz to 500 kilohertz, determinable through eight ranges.

The Plant for Telecommunications is also exhibiting the television customer service unit FSK 2 and the universal tube voltmeter URV 2 for repair and customer service.

The VEB Radio Plant in Dresden is exhibiting a completely automatic magnetostrictive ultrasonic materials testing unit MPG 1 in Hall 11 (Figure 14).

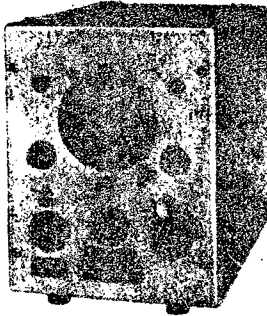

This unit, which has already been tested many times, can automatically test ferromagnetic round and profile materials for defects and can also be used for quality determination. With the aid of a supplementary apparatus, the composition of materials can also be determined within certain limits, permitting sorting of steel varieties with certain alloy components without chemical analysis.

Figure 14
Ultrasonic Materials Testing Apparatus MPG 1

The fault localization apparatus FGHL 1-2, also of the Dresden Radio Plant, is used to determine the location of disturbances on open-air transmission lines, especially high-voltage lines. It has special value for line monitoring in uninhabited or relatively inaccessible areas by means of direct reading of the distance of the point of disturbance from the measuring location. The apparatus is composed of the measuring part and the power supply part. The distance measuring range amounts to 100 kilometers for a five-line picture and up to 300 kilometers for a 15-line picture; the measuring inaccuracy is ± 0.5 kilometers.

The VEB Rafena Plant in Radeburg has developed a receiver-measuring transmitter EMS 563 for examining receivers in the frequency range of 1,590 to 1,910 megahertz (18.8 to 15.7 centimeters). The apparatus can ensure a continuously adjustable ultra-high-frequency voltage at a 70-ohm output for coaxial cable. Furthermore, transmission loss measurement can be made on four-pole circuits up to

8 N. Frequency measurements with an accuracy of ± 1 per mill are possible with the built-in wave meter.

Another highly valuable measuring apparatus is the modulation characteristic recorder MKS 205A for balancing and testing frequency modulators in the range of 30 to 40 megahertz. The apparatus permits the determination of the linearity of the object to be tested with the aid of a picture tube and a measuring unit which is calibrated in percentage. An indicator device calibrated in kilohertz makes frequency fluctuation measurements possible in the ranges of 0.5 megahertz ± 5 percent and 50 kilohertz ± 10 percent (in reference to the full deflection).

The compensation of outlet side-connected two- or four-pole circuits is frequently necessary in development and testing work. For this purpose, the disk-type compensators SK 771A (1,000 to 3,000 megahertz; $\lambda = 10$ to 30 centimeters) and SK 772A (600 to 3,000 megahertz; $\lambda = 10$ to 50 centimeters) are used. Compensation takes place free of losses with the aid of two dielectric disks in a patented arrangement which assures easier adjustment as compared to design types known thus far. Provision is also made for the suitable reproduction of the adjustments.

The quadruple meter III of the VEB Apparatus Plant in Karl-Marx Stadt is coming out with contact switching and in modern convenient cases. Its small internal consumption is to be recommended. The internal resistance for direct current measurements is 20,000 ohms per volt and, for alternating current measurements, 4,000 ohms per volt.

The ground leak and cable testing apparatus type 6004 (Figure 15), made by the VEB Radio Plant in Koelleda, is equipped with transistors and operates independently of a power supply unit.



Figure 15. Ground Leak and
Cable Testing Apparatus
6004

New construction elements in communications engineering for the apparatus building industry include the small relay K R 60 and a plug relay made by the Plant for Construction Elements in Communications Engineering in Grossbreitenbach. The VEB Telecommunications Plant in Arnstadt is exhibiting a double or duplex-medium wave variable condenser for transistor apparatuses. The soldering

guns manufactured by the same plant will be valuable aids in the work of many mechanics and solderers.

The new transistor hearing aid H 30 (Figure 16), made by the VEB Radio Plant in Koelleda, represents an essen-

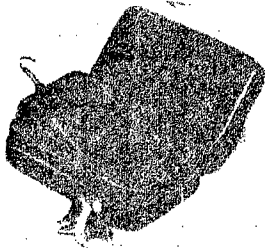

Figure 16

tial improvement in the present design. Special characteristics are the infinitely variable sound intensity regulator, the highly sensitive microphone, the connection possibilities for three different types of receivers, a built-in hearing coil for disturbance-free telephoning, and the adjustable transmission level limiter. Accessory: charging apparatus.

Transistor Hearing Aid H 30

The city department store in the midtown area of Leipzig is showing an interesting new product of the VEB Measuring Equipment Plant in Zwoenitz: the home sound recorder BG 23 (Heimtonbandgeraet) with accelerated forward and backward operation, volume indicator, and decimal band register. It is also distinguished by its simple operation, small weight, and attractive casing. The connection for a sound coupler is also provided for narrow tape amateurs; also, a sound mixer can be applied for compiling one's own recordings. The playing time is a maximum of 2 x 60 minutes; the tape velocity is 9.5 centimeters per second.

EAST GERMANY

The Role of Standardization in the Fulfillment
of the Chemical Program of East Germany

[The following is a translation of an article entitled "Die Rolle der Standardisierung bei der Erfuellung des Chemie-Programmes der DDR," by Dr Bayerl, published in Standardisierung, Vol VI, No 3, February 1960, East Berlin, pages 138-142; CSO: 4169-N/a]

The second KDT [Chamber of Technology] Congress held in January of this year and the Conference of the State Planning Commission held in February of 1959 both gave top priority to the detailed treatment of standardization problems. As a matter of fact, the speakers' favorite topic at the KDT Congress was how to focus all efforts of KDT operations section and professional union engineering intelligence on the essential problems involved in standardization.

But what the Conference of the State Planning Commission emphasized was the crucial importance of organizing first our basic industries and arousing the creative initiative of all workers in order to achieve maximum success. It has been said, and justifiably so, that our main economic task can be fulfilled only if we make not only better-than-ever use of but further steady progress with standardization and unification.

At this point it should be made clear that there is a definite difference between the already obsolete and up-to-date terms applied to standardization. Standardization under capitalism served the purpose of making profits for the manufacturer. This means that collective standardization existed only to the extent that it did not interfere with the profit-making individual enterprise. Under capitalism, industrial and product standardization was promoted even to such a degree as to prevent its specific application by competitors in the same field and to establish a monopoly on reproduction and repair of these products.

But standardization, as we understand it, means:

- 1) A standard parts system which facilitates design and production engineering
- 2) A standard system of streamlined production technology
- 3) Quality standard requirements
- 4) A selective limitation of series and variants of products
- 5) Standardized design and planning technologies

All these centralizing and selective limiting efforts range over and across the entire operational area of our entire economy.

Exceptions from the rule are made only in economically justified cases.

The spirit of standardization combines the development of the total productivity of industrial labor with that of quality production.

The chemical program has been given a central role in the fulfillment of the economic main task, and, as a matter of fact, the Seven-Year Plan has put its stamp of approval on the expansion of existing and the building of new chemical plant facilities to be financed by a capital investment of 11 billion [DM].

This tremendous program, in my estimation, can be realized only if the equipment, systems, and plant layouts required by the chemical industry are standardized and typed to the fullest extent of above outlined ideas and if a maximum effort is made here to apply the system of assembling standard prefabricated parts.

These tasks at hand are to be shared equally, of course, by the chemical, machine-building, and construction industries, whereby particular attention must be paid to the problem of cooperation among these industrial branches.

No less than about three billion out of the chemical program investment total of 11 billion are earmarked for industrial construction purposes. Therefore, it is well to analyze this amount and to estimate any pertinent savings resulting from standardization.

In this respect we can say that the cheapest way to build is still to use extensively standardized structural steel. The costs of building with highly standardized structural steel--even at the currently extremely high price of steel on

the world market--are still lower than those of all other construction versions. But since we cannot provide the large quantities of steel as required, we are forced (until enough steel is made available) to turn to the next cheapest construction material. This pertains to the use of prefabricated concrete structural elements. A stockpile of a broad variety of finished structural elements made available at the right time by the construction industry--in form of catalogs as well as construction-site material--can easily result in savings amounting to 15 percent where traditional concrete-construction techniques are concerned. There is the obvious additional advantage of reduced construction site crews because of the prefabrication feature involved. This includes the reduction of workers' accommodations, required at the construction site, which alone substantially facilitates building operations.

The next major item on the chemical program schedule is the production, assembly, and typing of equipment. The investment capital required for this purpose is between 5 and 6 billion. As in the case of the construction program, the difficulties involved here start in the planning stage.

Lack of prospectus material for bids, lack of other data--such as performance and warranty conditions, not to mention fixed prices, make life difficult for the planner in his dual function as a new plant designer and investment trustee.

How convenient it would be to rely on standard type with well-known performance ratings and available in well-defined production run selections. This would save the planner 30 to 40 percent of his time. A similar situation prevails in investment control. How many stock equipment items have excessive dimensions even today because there are no safe minimum performance ratings available! How many retroactive design and field engineering changes are still necessary because the delivered equipment components do not match the previously published mounting base and attachment specifications!

How much could be saved on plant productive labor if the major part of the stock equipment items could be run off in truly serial production line fashion! For only by the selective limitation of runs (which today are far too numerous) is a sufficiently large-scale serial production possible.

Equipment requirements include those for testing and control instruments. In this respect, the chemical program's capital investment requirements are estimated to be 0.8 to one billion. Of this amount, about 0.4 to 0.5 billion are earmarked for about 100 to 120 interchangeable standard parts. These can be used for entirely serialized production runs. Or is there any other way (that is, without series production of this kind) to carry out this super program?

At this, as at no other stage of operations, we can see clearly that no further progress is possible without a parts typing and interchangeable parts system.

A similar case in point is that of electric power equipment. The only reason for a slightly better situation prevailing here is the much more advanced planning work done in this industrial sector. Today no special order is given by a customer (if he can help it) for a custom-made electric motor winding. On the other hand, the Leuna Works even today put out their control and testing instruments in their own shops.

The chemical industry's task is to carry out by socialist reconstruction means an expansion of production, not only in quantity but in terms of starting entirely new manufacturing lines; in doing this, particular attention must be paid to keeping the increased labor force requirements for investment and/or production expansion down to a minimum level.

According to the highly competent literature already published on this topic (such as the article by Dr Blauhut in Chemische Technik, May 1959), "the task of socialist reconstruction must be translated to corresponding requirements for the chemical and machine-building industries for maximal utilization of planned investments."

Essentially, these requirements are:

- 1) Transition to a continuous system of production of which the final result is maximum automation and uniformity of quality production
- 2) Maximal output in minimal operational space--boosting of hourly throughput per system--reduction of standard operational units coupled with a cutback in servicing personnel
- 3) Manufacturing and setting up of special purpose machinery typed for output ratings which are adjusted to the special conditions of chemical plant production.

Only by fulfilling the above requirements will it be possible to carry out the extremely extensive investment program with the funds and labor force available.

We must emphasize here that we have taken over from the capitalist past, which had an extremely scattered type of production. Since then the majority of our industrial plants have operated as single-piece production units. The result is that many items used for the same engineering purposes are put out in physically or administratively separate plants. These items (including most of their spare parts) are not interchangeable. Clearly this is not a reliable way to centralize all technical equipment on a nationwide scale.

We have had this experience in the past--namely, that technical items having the same function but were purchased from different manufacturers could not be replaced by interchanging these items.

All this runs contrary to the most elementary rules of national economics, as well as the conditions basic to a successful solution of the socialist reconstruction task.

The need to overcome the heritage of capitalism has become acute--for instance, where it has become necessary to eliminate 92 percent of the existing assortment of screw production to satisfy the industrial requirements for interchangeability. Right now there is a project in progress to establish technological standards--in agreement with those of machine-building sector--for pumps, compressors, and armatures, as well as other chemical industry equipment which would make available to the chemical industry the above-listed equipment only in precisely defined types having special output or quality ratings. To speed up this kind of type-specialization work by weeding out what has been listed in stock and offered for sale up till now, it is imperative (in some sectors at least) to employ an increased number of apprentices with an engineering background. Last year at the KIB Chemie in Leipzig we assigned junior engineers to work on such projects under the supervision of chemical industry specialists. Up to 30 junior engineers at a time were deployed to work at the most diversified tasks. Their work had gratifying over-all results. To solve similar tasks, we plan to employ more young colleagues of this caliber.

This development of standardization will not only have centralizing and streamlining effects but will result in many extremely important advantages, for instance:

- 1) A much higher degree of interchangeability of single parts
- 2) In connection with this, a simplified and less costly method of storage
- 3) An easier method of spare-parts provisioning
- 4) A reduction in floating accounts
- 5) A decreased load on servicing organizations and increased savings on operating personnel

Each problem by itself is important enough to demonstrate the role and significance of the standardization tasks on our schedule.

To expedite these important tasks, the State Planning Commission for the chemical sector has tried the experiment--by creating the "Coordination Office for the Technological Standardization of Chemical Industry Equipment"--to establish close consumer relations with the machine-building sector in order to boost the output ratings in the chemical technological equipment department. This way a basis was also created for working up a system of pertinent professional standards.

The work of the coordinating office depends on the guidance of a Scientific Advisory Council composed of experienced technicians of the entire chemical industry.

According to its mission, this office tries to establish a relationship of trust with all the other central offices, technical colleges, and trade schools, as well as state academies to expedite, by socialist teamwork, the publishing of a high quality professional standards manual which would be of equal importance to both industrial sectors.

Aside from the capital investments, the particular importance of standardized chemical industry stock items lies in the planning of chemical plants.

As is probably known to everybody concerned--the lack of planning capacity represents a bottleneck of the first order in the chemical program.

But in order to start already in 1961 operation of huge chemical plant capacities, our first concern must be maximal rationalization applied not later than at the planning and designing stages. Because the planning capacity particularly as concerns chemical feeder equipment (electric-power planning, testing, and control techniques, heating and ventilating sys-

tems) is limited to a high degree, it is extremely important to be able to rely on standardized equipment.

To ease the burden of working out variants from the over-worked drafting and planning offices for chemical equipment and also to help the machine-building sector to concentrate its small pipeline-designing capacity where it counts, it has been suggested that the chemical sector put out a test model series of chemical plants.

With these test series (with its key components built to scale), it will be possible to work directly from construction site models instead of assembly blueprints. This applies also to the setting up of equipment and assembling of pipelines. Estimated savings on drawing-board work by using test model serialized standard parts amount to no less than 50 percent with a reduction in total planning costs, even taking the provision of model parts into consideration.

Beyond this immediate picture the planner gets a larger-scale and clearer idea of the need to concentrate on standardized equipment parts; if he does not do so the building of models may have to be chalked off as a waste of time when the large-scale production unit to be built later cannot meet the only acceptable--that is, up-to-date--standardization requirements.

Preferably (and in my opinion also logically) the machine-building sector should be able--in agreement with model-planning specifications for production jobs to be done by the same sector--to deliver the model standard parts for planning operations.

Consequently, the rejection of a model standard part by the planner would result in such parts being individually reproduced, and this would mean that later on, also on an industrial scale, a newly reproduced part instead of a standard part would have to be used.

Following a KIB [not identified] planners' suggestion, an interplant socialist collective has been created where production line workers and chemical and mechanical engineers sit down together to discuss the following problems:

- 1) How to simplify work by model planning
- 2) How to design models of pipelines and boiler jackets and how to determine the most suitable material for them

3) How to obtain suitable photographs for construction site evaluations and progress recording purposes.

4) How to plan future developments by using project models and how to follow through on their realization

5) How to organize exchange of data among pipelaying brigades.

At this moment KIB, colleagues as well as other chemical industry planners are evaluating (though still on a small scale) their experiences with making pipeline models.

Regarding the standardization of armature (boiler jacket) models, the KIB engineering collective is now engaged in a project to work out pertinent suggestions based on graphically represented standard symbols.

Data collected from making plant models will be instrumental in the designing of a standard model prefabricated parts system for model-planning purposes. Accordingly, the advantages of this planning innovation are extremely manifold.

It is hoped that future progress in this field will make it possible to make the collected data (preferably in connection with already worked up model parts) available to all who are obliged to manage their tasks under accelerated conditions and with smaller crews.

Let me make now a few comments on the national economic significance of standardization in the chemical plant building sector:

Data collected from international publications reveal that the mean life of a chemical plant (from the viewpoint of operational efficiency) today is estimated to be about seven years. Although this estimate substantially was made up from capitalist research data abroad and is based no doubt also on the capitalist expediency of prematurely writing off such plants for capital accumulation purposes, it is clearly recognized, even from our side of the fence, that the life of a chemical plant (on account of the fast operational turnover) is shorter than that of most other economic assets. Accordingly, the planners of chemical plants must be particularly sure to

1) operate with the most advanced technology;

2) watch the time coefficient--that is, starting building operations immediately after planning them, otherwise valuable production time will be wasted even in building the plant.

Under the present conditions, the planning of a chemical plant (as outlined above) cannot be an individual act but must be a complex collective job shared by all the disciplines of natural sciences, from mathematics--ranging over all fields of physics and chemistry--to machine-building. This work will have positive results only if all those contributing to the planning of a chemical plant find a common language and are ready to achieve the aim of socialist planning by planning a plant that meets the requirements of maximum economy. To realize this aim, certain basic concepts leading to a division of labor have been worked out on a worldwide scale--that is, on equal terms by the socialist and capitalist camps. These basic concepts can be translated into a chemical plant made up technologically of standard operations of a physical nature which are interconnected by special purpose equipment for chemical conversion.

Standard operations are, for example, crushing, grinding, straining, filtering, cooling, condensing, and similar jobs. But in many cases standard terms have also been established for the chemical reactions linking these standard operations, most of which have been supplemented by pertinent standard equipment terminology.

All over the world, the problem of planning and target setting, designing, and producing the equipment needed for standard operations is that of the machine-building industry. Therefore, at this industrial stage it is not too early for standardization work to begin. There are large industries having extensive research facilities which study--aside from problems of the chemical field--such standard operations and pertinent standard equipment.

Regrettably in the GDR the organizing of research of this kind has not yet been understood as well as it has been particularly in the Soviet Union and also in some capitalist countries.

The integration of standard equipment furnished by the machine-building sector into chemical processes or the building of a chemical plant is the concern of the project engineer, who in turn receives basic information on the chemical conversion taking place in pertinent equipment from the chemical industry research laboratory.

The division of labor described by me is the origin of and key to a successful practical solution for building chemical

plants quickly. It gives the project engineer a chance to speed up the plant building phase by arranging standard equipment engineered by the machine-building sector in such a way as to keep functional equipment (reactors) for chemical conversion processes down to a minimum level.

To carry out a chemical investment program of the order planned by the governments of the GDR and the USSR, it is imperative for the machine-building and chemical sectors to plan ahead by specific ways and means.

Another extremely important problem is the pertinent cadre selection and cadre training.

This was recognized to the fullest extent by the Soviet Union some time ago. This is why, for several years now, the training of machine-building project engineers for the chemical sector in the USSR has been kept on a highly professional level. For the same reason the central scientific institutes of mechanical engineering, which operate as development departments of the State Chemical Commission of the USSR, have been greatly expanded.

The Moscow Central Institute "Niechimasch" alone operates with a personnel of more than 2,000; its sole purpose is to research all problems in connection with the design of equipment used for the separation of liquids from solid materials.

The above equipment includes various filter systems, centrifuges, and separators. This central institute is in charge of all the other field institutes spread out over the entire area of the Soviet Union, which in turn work on the peripheral problem complex dealing with the standard operational aspect of chemical engineering.

I was told that the total personnel count of the Soviet Union's scientific institutes working on chemical engineering developments has now risen to more than 10,000 men.

These institutes also cooperate on planning the publication of a handbook series on the supply and engineering changes of equipment for standard operations. These series will contain all standard types of equipment, armatures, pipelines, and standard specifications for chemical plant-building investments. The publication of this catalog was scheduled for the fall of 1959. I assume that it has been issued by now.

Furthermore, over a period of almost three years--between 1957 and 1959--handbooks were published on project cost estimates and target control, which fix the relationship between investment and planning costs for almost any chemical industry project.

The Moscow Central Institute includes a pilot plant with a crew of over 1,000 men who put out chemical apparatuses. This plant has no production plan in the usual manufacturing sense but limits its production to the making of prototypes for scientific research work to be done by the institute.

Aside from the planning of huge chemical investment programs, the Soviet Union has, over a period of several years, conducted a systematic search of international chemical industry literature on economic coefficient data of a very interesting nature, which permits the Soviet Union today to establish extremely precise investment requirements on a national economic scale.

Regrettably, these standards are not yet available to the GDR project engineer. He still lacks the know-how for working up many scientific engineering and economic project specifications and a definite advance planning procedure which would permit the utilization of the prefabricated parts system for erecting chemical plants with the support of the machine-building sector in meeting investment target requirements ahead of time.

In most cases, the lack of any prerun-planning schedule prevents the engineer from keeping up with up-to-date technological achievements; in some cases he is even obliged to build a plant knowing, even in the planning stage that at its operational stage the plant will have lost at least half if not more of its seven to 15 best service years.

To remedy the problems which are of immediate concern to us, it is suggested

- 1) that active cooperation and agreement with the standardization agencies of other socialist countries--particularly the Soviet Union--be substantially improved--that is, with special emphasis on chemical engineering;
- 2) that the chemical planning and machine-building sectors under the guidance of the chemical industry come to a definite agreement on research and design programs in the field of standard operations; furthermore, that machine-building be

made responsible for making available (if possible, in cooperation with "Niichimasch") to East German chemical planning the apparatus [necessary] for realizing its investment projects.

An interesting case illustrating the effects of standardization, type unification, and machine-building by the prefabricated parts system is that of the large-scale construction project in Guben. If this construction project had relied only on the machines and equipment now in use in the GDR, it would have resulted--aside from the 10-percent increase in investment requirements--in rather substantially decreased labor productivity. This in turn would have resulted (at constant unit production) in manpower requirements estimated at 8,700 men. The manpower requirements for the repair shops alone (to handle regularly scheduled repairs of all semi-standardized and machines made from prefabricated standard parts) would have been at least 1,500 skilled technicians.

After consultation with all colleagues in the machine-building sector and with the support of public organizations, the State Planning Commission, and particularly the KDT, we succeeded in getting a pledge from the machine-building sector to deliver from now on machines which fulfill to a high degree our standardization and prefabricated parts system requirements.

This resulted in a drop in repair shop employment from 1,500 to 500 and in a total decrease in personnel of about 20 percent.

A further streamlining of the work process involved and other measures taken by us have resulted in final savings in which both the labor productivity and the reproduction of the capital investment--as far as we know--put the project on an acceptable equal footing with installations currently operated abroad.

In conclusion, I would like to repeat and/or emphasize at this point a well-known fact--that in case of expanded socialist reproduction (planning and carrying out of investment projects) the actual rate of progress basically depends on the economic time coefficient. The key problem is therefore to reduce the time between starting and completing investment projects. The means for this is drastic standardization and type unification.

Last but not least, expenditures for the construction and equipment for new plants depend on the degree of standardiza-

tion of the plants. Standardized operations, projects uniform in type, as well as standardized structural elements and systems will substantially control the speed by which investment projects are built and set the level of costs.

Therefore, the contribution and cooperation of all concerned is necessary to increase labor productivity by means of standardization and consequently to ensure the fulfillment of the chemical program.

EAST GERMANY

Standardization in the Use of Printed Circuits

[The following is a translation of an article entitled "Die Standardisierung bei der Anwendung gedruckter Schaltungen," by Maximilian Bless, published in Standardisierung, Vol VI, No 3, February 1960, East Berlin, pages 145-150; CSO: 4169-N/b]

A survey of production methods in industrial electrical engineering, with special emphasis on the whole range of telecommunication engineering, reveals that this industrial branch still depends on a high proportion of manual production.

Older industrial fields--the textile industry, for instance--have matured over a century to a considerably high degree of mechanization. The automobile industry has operated for many years on almost fully automated production lines, and many large-scale chemical plants have for some time been using remote-control console equipment. Most industries have, in the course of the last few decades, gone through an intensive development of their technological processes.

In this respect the retarded progress of electrical engineering is traceable to two basic facts: 1) the difficult problem of installing wired circuits into equipment; 2) the low wages paid for wiring work, which are out of proportion to the total production costs of equipment. Only since the labor problem in all industrial countries has become acute, has engineering started considering seriously how to improve wiring production techniques.

Today in many branches of electrical engineering the new production technique of printing circuits has already made rapid progress. Its major field of application as of today is that of telecommunication engineering, and particularly that of manufacturing radio and television sets. It can be assumed that today already about 60 to 70 percent of the radio and television broadcast receivers on a world-wide scale are equipped with printed circuits.

All over the world, and also in the GDR, many experts in the field are occupied with problems which have both a tech-

nological and an economical stake in the introduction of printed circuits.

For a better understanding of the basic subject matter, I will try to outline briefly the operational cycle of making printed circuits. The name of this technique was derived from the printing process involved. In the initial period of working with printed circuits, the actual application of electrographic inks was tried and even then included experiments in incorporating resistance points into printed circuits. For this purpose carbon black-graphite-lacquer compounds were used. Later on, a whole series of procedural variants was added, of which today there remain only about 10 to 12 in actual use.

But the most representative of procedures in active use now is the foil-etching method, and the following treatment of this subject will be limited almost exclusively to this process. In the GDR still widely used are the silver-powder molding methods and the production of silver tracks bended to ceramic panels. The foil-etching method builds on a so-called base material, whereby a copper foil is mounted on a board made of insulating material (usually laminated paper). The open surface of the copper foil gets a protective or anti-etching solution coating (accomplished by various means) along the lines of its permanent circuit pattern; the usual coating methods are photosensitive, screen, and offset printing processes.

At this preparatory stage, the base material is subjected to an etching treatment, whereby the unprotected copper-foil areas are removed by acid. The subsequent removal of the protective layer from the conductor lines produces a conductor board ready for use. I am omitting here the description of peripheral operations involved (for example, the making of stencils or the post-etching neutralization of the conductor board).

Following protective coating by solderable lacquer means, the conductor board is perforated according to a functional pattern. These holes are used to accommodate the hardware inserted into the board side opposite the copper foil side. The electrical connection of the contact terminals and also part of the mounting barriers is made manually or by dip-soldering.

The Development of Printed Circuits in the GDR

Initial research on automating the insertion of circuits into electronic equipment was started shortly after the end of World War II. These efforts were channeled first by the "Permanent Wiring" operations group, later known as the "Printed Circuits" operations group. More intensive research phase of this new technology started around 1954. From this date on, initial efforts to standardize printed circuits can also be traced. Since establishing the FNE [Technical Standard Committee for Electrical Engineering] Branch 307 "Printed Circuits," the GDR also officially entered the picture. This means that from the beginning, work on all-German standardization was a collective undertaking. Preparatory work done since 1956 on introducing this technology into the production phase resulted in the mass production in 1958 of the first "Minorette" and "Bobby" radio sets. Since then, the printed circuits have been used in many fields also in the GDR. Instrumentation, commercial broadcasting, and computer engineering are seriously considering the adoption of pertinent measures. In the field of general purpose electrical engineering, there are also indications that the use of printed circuits will be started. Even today it can be said that the early preoccupation with standardization schemes by those working with printed circuits has very strongly favored the coming into use of this technology. The following observations offer an analysis of why this technique depends on standardization.

Basic Observations on the Standardization of Printed Circuits

Professor Koloc of the Dresden Institute of Technology has defined standardization as a function of simplification; which in turn is part of the complex of measures taken to achieve what we call automation. Standards are justified only in case of large-scale mass production. Aside from the systematic principle and all factors connected with it, standardization has a strong economic component.

The economic targets of standardization are reached by reducing the number of types, the operating and material costs, by the interchangeability of standardized parts and the economy of thought processes involved. In this respect, a standard is an identical solution for a task to be repeated over and over again.

But standardization also has two more requirements--first, that no single standard contradict another one, and secondly, the so-called junction safety feature. This is important where printed circuits are concerned--particularly if the mechanization and automation of operations are planned.

Although standardization in the field of telecommunication engineering has been sufficiently advanced in regard to certain properties and dimensions--for example, perforations, axial lengths, mounting points, electric power ratings, properties and/or definitions--the current requirements for printed circuits call for an extensive system that includes all dimensional data, from base material, conductor board and hardware, machining and pertinent tool specifications to packaging data.

For the printed circuit the rule established by Germany's father of standardization, Dr E. H. Hellmich, applies to a high degree: "Standardization means the transition from obstinacy to public spirit." For the first time printed circuits used in electrical engineering offer a chance for automated production. However, any automated production results in a constant type of mass production, which can be achieved, of course, only by consistent application of standardization.

A further compelling reason for extensive printed circuit standardization is the close cooperation with many other industrial branches which is necessary for total success. The large-scale chemical industry, metallurgy, over-all machine-building, a large sector of over-all and specialized electrical engineering such as polygraphic, automatic machine, galvanoplastic, and hardware engineering are expected to work rather closely together if the rationalization potential of printed circuit technology is to be exploited in a maximal way. Their medium for mutual understanding is standardization.

The Current Level of the Standardization of Printed Circuits

The concept traceable from the beginning throughout the entire standardization work area is the necessity of standardizing technical terminology. Translations from various languages have resulted in various interpretations by individual translators which were formulated independently of each other and which have led to mutual misunderstandings of specific problems. Therefore the working up of each single

standard had to be coupled with a search for the correct definition of it. Permit to select the most important definitions of terms now established for standards or designs:

Base material = copper-clad insulating material
Carrier material = base insulating material
Copper foil = carrier-mounted and mostly electrolytically produced copper foil
Conductor board = Insulator board bonded with conductor lining
Printed circuit = Hardware-equipped conductor board; hardware is either bonded to, inserted into, or in electrical contact with conductor board

Up till now the most important standard in the field of circuit-printing was the DIN 40 801 "Printed Circuits, Technical Instructions." This standard is practically the bible for this entire engineering sector. Aside from its definitions of conductor board and printed circuit, it contains all the essential facts there are to know. Because of their importance, I would like to dwell on specific chapters of DIN 40 801. Paragraph 2 defines so-called standard grid measurements. The requirements call for possibly all perforations to be located at junctions of a rectangular grid having a network of 2.50 millimeter-size squares. At first, the importance of this definition may not be apparent. But in practice it establishes a standard for all basic printed circuit design dimensions. That is why just at this point of standardization the most bitter argument has developed over a period of several years, which even today has not been completely resolved. Originally, this particular grid standard was developed in the USA, and from there it found its way into the standardization proposals submitted to the International Electrical-Engineering Commission, and this by using specification data based on the inch-scale system. This applies not only to the grid standard unit but to the rest of the definitions involved. In the course of meetings held by the Technical Subcommittee No 40 of the IEC [Electrical-Engineering Commission], the inch-standard problem has finally become the butt of a basic argument between the two systems of measurement--inch or metric scale. The IEC has fixed 1/10 of an inch convertible to 2.54 millimeters as the basic measurement. This is even more inexplicable when one considers that the 1/10 inch standard does not fit even into the normal inch-scale system, which works with fractional values of 1/4, 1/8, 1/16 inch, etc. The debate on whether to recognize the inch

or the millimeter scale standard has dragged on through several international meetings, and in practice the international yardstick applied by the IEC to standardizations today is the inch. Also, the attempt to establish the metric system at least for the whole of Europe was not successful. Even France, the traditional birthplace of the metric convention and guardian of the primary metric standard, who was naturally expected to speak up for the metric system, pleaded for the inch standard. This indicates how much France is already bound by the NATO alliance to the American system of measurement. The fight of the all-German Board of Standards for a metric system of measurement gained the effective support not only of the GDR but of all other people's democracies. Lately, another attempt has been made to standardize the metric system on an international scale. These efforts were without success. The firmly anchored position of the inch-scale system--as per IEC publication 97--has been unchanged. This is regrettable for another reason--namely, that the IEC is obliged to conform to the work rules established by the ISO [International Standards Organization], of which recommendation R 31 has clearly fixed the mks-unit system as the master system of measurement.

It may seem that the close standard-grid tolerance of 0.004 millimeters is not that important. However, subsequently compounded deviations from the norm on the one hand and maximal precision requirements for standard grid reference points on the other hand cannot be discounted--that is, in case of printed circuits to be equipped at some future time with automatic means or in case of any future computer-programmed production of machine-riveted grid perforations. Only a high degree of precision checking grid-perforation to tolerances can ensure a proper hardware fit.

DIN 40 801 further specifies the nominal thickness of the base material--that is, of the carrier material plus copper lamination, including bonding agent--as ranging from 1.0, 1.5, 2.0, 2.5 to 3.0 millimeters and preferably 1.5 millimeters. Grid-perforation specifications are 1.3 + 0.1 millimeters diameter for base materials up to 1.5 millimeters thick. In terms of hardware requirements, this makes for strictly standard-grid arranged contact terminals and mounting accommodations according to 1.3 + 0.1 millimeter diameter standard perforations. Prior to establishing this standard, exhaustive tests were made to check the mechanical strength of standard hole-accomodated mounting lugs also in case of larger

hardware equipment. This has established the fact that, for example, large-size electrolytic capacitors with three or four grid-mounting accommodations also pass considerably high mechanical stress tests.

DIN 40 801, paragraph 5, fixes hardware standard dimensions. Aside from the previously mentioned requirement of a perfect fit of contact terminals and mounting lugs in standard grid-made standard perforations, additional requirements call for a specific terminal shape for easy hardware insertion into the conductor board. Furthermore, to improve operational stability, mounting lugs and terminals used for this purpose should be equipped with conductor-side attachments. This paragraph contains also specifications of mounting lug and terminal lengths up to the preferable nominal base-material thickness of 1.5 millimeters.

The publication of standards for printed circuits has provided systems and design engineers with reliable data on how to find a perfect match, within the entire technological and experimental range, for each conductor board set hardware contact with assurance of interchangeability of the hardware products. In this way the publication has substantially contributed to the stimulation of development and design activities in the field of printed-circuit hardware.

The actual implementation of this project does not mean that all perforations will meet grid-standard requirements. However, it is hoped that system developments and designs will fit as many perforations as possible into the required grid standard and will work with standard-hole diameters. To emphasize the importance of DIN 40 801, let me pick out a specific problem. A characteristic of the printed circuit is that many perforations are put into a conductor board. In the average grid-perforation job there are 40 to 50 perforations per square decimeter of conductor-board space. That is why for some time now research has been going on on how to produce technologically and economically flawless perforations. Between the two operational extremes--drilling each single hole or machine-cutting the entire grid-perforation job--a series of operational variants are now in practical use. There is, for instance, the porcupine punching tool (Igelstanzwerkzeug). This method utilized a spiked die which cuts each pin-pointed grid intersection. (The cutting plate has holes corresponding to grid points to be cut.) This cutting tool, which can be converted quickly into a special-purpose tool for any unique type of conductor board, cuts all grid-

laid perforations in a single operation. Another approach is to work with jigs, whereby a single jig-bore or cutting tool performs one perforating job after another and whereby the conductor board--by picking up a jig for each successive job--is moved under the jig-bore or cutting tool. An adaptation of this method utilizes a complete set of cutting needles of which the sectional release is computer-programmed for each linear perforation job. The prerequisite for these methods is, of course, the establishing of a grid standard. It is clear that this standardization step is also economically well taken with respect to small-scale unit production.

Standardized printed circuits are of equally great importance, of course, if applied to the automatic method of equipping conductor boards. The economic efficiency of this relatively sophisticated circuit equipment depends on a high conversion factor. That means, of course, speedy packaging adaptability. Today it is quite impossible to imagine automatic packaging machines designed for nonstandard grid equipment; dimensionally those nonstandard machines would be in such a mess as to cancel out their actual value.

The importance of DIN 40 801 is matched by that of specification proposal DIN 40 802, "Base Material for Printed Circuits, Testing Specifications, and Procedures," published in Elektronorm. In essence, the TGL [Technical Standards] specification proposal O-40 802 dated November 1959 complements DIN 40 801. This standard includes all electrical and mechanical base material properties and specifications of pertinent testing procedures. It takes over standards already established by DIN 40 801. In drafting this standard, certain difficulties developed because many established standards had to be checked and the interests of base material manufacturers and consumers had to be coordinated. To illustrate: good penetrability must be paid for by higher water absorption. Laminated paper is resinated to the extent of permitting perforating operations. This in turn raises the level of water absorptivity.

The TGL O-40 802 data establish minimum values. Nominal values for copper foil are $35 \mu\text{m}$ [0.035 mm] + $10\mu\text{m}$ or $-5\mu\text{m}$. Further values fixed are penetrability, solderability, water absorption, adhesive strength of foil, carrier corrosion resistance to copper and copper alloys. Among the minimum electrical property requirements the TGL proposal lists values for surface impedance, specific insulating resistance, dielectric loss factor, and dielectric strength.

Of all the requirements mentioned above, there are three worthy of further analysis. Penetrability is extremely important. In view of the high number and (in spots) extremely close arrangement of functional perforations, good penetrability of base material--if possible to be accomplished without producing too much heat and without breaking web ribs--is essential. For this purpose, TGL-tool specifications list a so-called punch verifier. In case of multiple-piercing operations, the breaking strength of a one millimeter-wide rib serves as a yardstick. The economic efficiency of perforation-machined laminated paper, Class IV, depends on the lamination properties involved. The minimum specifications listed in TGL O-40 802 call for insulating material carriers of laminated paper, Class IV, and better. Therefore, the interest in the degree of penetrability is justified.

The correct way to dip-solder printed circuits is to work at maximum soldering flux temperatures and minimum time spent actually on dip-soldering operations. This way the thermal load on the hardware--particularly when working with semiconductor elements--is kept at a minimum level. Further advantages of high dip-soldering temperatures are: lower tin consumption, fewer cold soldering points, fewer adjacent conductor spots bridged by excess soldering material and the chance for using a less active soldering agent. This is particularly important in view of the required corrosion resistance of the finished printed-circuit product. The prerequisite for attaining high operational flux temperatures is, of course, a high thermal resistance of the base material. By high temperatures we mean temperatures around 250 degrees centigrade at operational dip-soldering times of 3 seconds or less.

Foil adhesion to the insulating material is important to the extent of hardware contacts and mounting lugs developing a take-off force which tends to separate the foil from the carrier, and in case printed-circuit repairs are to be made.

The whole problem of adhesive strength and the bonding agent by which the former is accomplished plays an important role in base material production and also represents one of its technological trouble spots.

The scientific-engineering collective work put into the two standards--DIN 40 801 and DIN 40 802, and its offspring TGL Specification Proposal O-40 802--probably cannot be truly estimated at this time. Even if sooner or later a revision of this standard work to match technological progress can be

expected, it has clearly created the basic conditions for an important technological step forward, which opens up a totally new perspective with major consequences in the economic field.

Even today it is becoming clear that in the course of further developments it will be necessary to establish a grid standard with smaller than 2.50-millimeter dimensions. Even now this grid standard is too large for miniaturization engineering purposes. In the case of working with smaller standard grid dimensions, the IEC Publication No 97 recommends halving and, if necessary, quartering of the standard grid.

Developments in the hardware field have produced a whole series of printed circuit standards, such as those for paper capacitors, electrolytic capacitors, variable resistors, electronic tube sockets, and others. All of them are based on DIN 40 801 "Printed Circuits, Technical Instructions." Beyond these basic requirements, they must meet all standard property requirements for printed circuit hardware such as small volume, small base, dip-solderable contacts, detachable screening covers (for instance, of waveform selectors). This type of equipment must be resistant to stress conditions developing later at the half and fully automated phase of equipping printed circuits. Other specifications--if possible, magazine storage--require small-size capacitors and tubular resistors to limit their leads on both sides to axial types, to mention only the most important characteristics as specified.

Some of the conventional hardware need not be converted for any special purpose, and some of it can be utilized over a transition period by means of compromise solutions. However, a large segment of equipment remains for which a new design engineering approach has been and is still essential.

There is still much work to be done in the field of standardizing printed-circuit hardware--work to be sponsored for speedy and streamlined delivery.

The system selected from workable types of magazine storage consists of hardware having axial leads which are taped between two paper strips. The taped-hardware belt is rolled around drums or laid in for specially built magazine storage. Appropriate standards have been worked out and submitted as a TGL specification proposal. The successful processing of this standard immediately opens up a large new field of technology.

It is understood that this procedure applies only to hardware equipped with axial leads. For other hardware types, for example electronic tube sockets, other magazine storage versions must be utilized. But for this possibility suggestions are also already on file. The development of magazine storage consequently leads to equipment for automatic testing procedures, specifically in case of manual equipping operations to an automatic prepackaging of hardware items; in case of automatic equipping operations, this type of storage represents no less than the operational base of putting automatic equipping testing systems to work.

The Standardization of Technological Processes

The qualitative selection of the foil-etching process has already contributed to some progress in process-engineering standardization. As explained before, the establishment of prime standard DIN 40 801 has increased the possibilities for standardized engineering processes, in not only a developmental but in a practical way.

Developmental research done in the field of printed circuits promises an acceleration of processes involved to be accomplished by the selective use of maximal efficiency procedures. A way must be found to establish one or two workable methods of etching and dip soldering for standard-operational use in the GDR.

The particular economic advantage of the foil-etching method is its extreme adaptability to production scope requirements. This prevents standardized engineering processes--at a certain level of piece production--from becoming economically unmanageable. On the priority list are only those engineering processes which are on the critical list anyway and which require further technological development, as for instance post-etching neutralization, on which the chemical resistance of printed circuits depends.

Standardization of subsystem engineering processes is expected to result in more simplified production media and systems. By working with typified auxiliary tools and materials, standardization is expected to increase labor productivity right up to the industrial supply phase, with a resulting reduction in production costs.

In the dip-soldering and etching departments, process standardization is already on its way to realization. Another important field worth of exploration in this direction is that of fully automated printed-circuit control equipment, the basic conditions for which are particularly favorable. The simplest way to package indicator and monitoring equipment circuits is by means of adapter and electric terminal board, and there are developmental indications pointing to a fully automated integration of circuits and other electrical system components.

The Specific Task of Introducing Printed Circuits into the GDR

The mission of vigorously supporting the use of printed circuits is the concern of the whole of the German Democratic Republic. In this respect, the socialist type of economic management offers particularly favorable working conditions because it is independent of individual capitalist industrial interests.

In automated equipment plants, a completely equipped conductor board leaves the automatic assembly line every two or three seconds. By working in shifts, such a line could meet the supply requirements of the entire population of the GDR for radio and television sets and beyond that a substantial part of any export production. This alone justifies the compelling need for an intensive study of this technology.

To create the basic conditions for introducing a system of this kind, it is important (as outlined previously) to have a secure foundation of standards. This in turn is based on a greater professional interest in printed circuit techniques than is shown now.

Therefore, the task of all those in policy-making and responsible positions is to promote particularly the research engineering work done in this sector.

In the field of exchange of scientific-engineering data, the Chamber of Technology has already done an excellent job. The cycle of lectures on the subject of printed circuits, which has run its course in each district, has introduced a large circle of professionally interested technicians to this technique. At many more exhibits and engineering collectives, exchange of data has already borne fruit. Worth mentioning

is the industrial symposium on printed circuits which was held at Dresden on 25 June 1959.

Also, many plants are doing preliminary work in the field of devising new standards. In this respect, I would like to mention the working out of operational requirements for miniaturized electronic tubes used in printed circuits or the proposal of the VEB Ceramic Works in Hermsdorf for "Engineering and Supply Specifications for Ceramic Carrier Boards."

Many problems still have to be solved. For example, how to organize on a broad scale the GDR Postal Transportation and Trade Organizations, including the DAMW and DAMG [not identified]. There is still much standardizing work to be done in the field of electrical contact hardware, which can be said also from an over-all German point of view. Even in TGL Proposal O-40 802 there are still no data published on board sizes of base material types. This despite the fact that it is essential--for the sake of operational economy--to establish a standard size for this semi-finished product, which is expensive in any case. Furthermore, there are many peripheral problems to be solved--for example, how to standardize test patterns for foil-etching purposes, and so on.

Very little has been done about industrial safety in printed circuit work. In this respect safety standards are still lacking for dip-soldering operations, working with combustible accessories and acids for etching jobs--just to name a few industrial applications.

On Cooperation with Other Socialist Countries

For some time now an exchange of scientific engineering data with the Soviet Union has been going on, with a strong emphasis on standardization problems. In the Soviet Union the work done on printed circuits has already reached a high technological level. On standardization, the National Committee representing the Soviet Union at the IEC meeting held in Zurich in October 1957 came out strongly in favor of a standard grid based on the metric system.

An agreement with Czechoslovakia on coordinating efforts has been in force since 1957. In several mutual consultations, a liaison was also established on specific standardization and cataloging problems.

A similar relationship has been established with the People's Republic of Poland. Collective research is already in progress, and agreements made on printed circuits include efforts to come to a specific economic agreement. It is understood that an exchange of (interchangeable) printed circuit hardware depends on its being mutually standardized.

Outlook

There is a well known proverb: "You must know much to know that you don't know anything." The more we work with printed circuits the more obvious becomes the fact that we stand not at the end but at the beginning of an active development. To make an over-all prediction for the entire field of printed-circuit techniques: Ahead we see (if nothing else) the phase of miniaturization. Already available results--for example, a tiny radio set built according to the so-called module standard technique, and having miniaturized electronic equipment arranged on a stack of square wafers or conductor elements each no larger than one square centimeter--indicate the general trend of this development. What is needed now is to utilize this technology (which is a perfect testing ground for demonstrating the superiority of our socialist management) also in a broad and long-range economic sense. What this technique needs is enthusiastic developers, designers, and technologists who will not capitulate when they encounter setbacks but are ready to make public--and if necessary to correct--their scientific records and experiences in a constant mutual exchange of data.

I am convinced that GDR telecommunication engineering has entered--by way of introducing printed circuits--its grand phase of technological development which, however, is in need of intensive standardization. But the accomplishment of this means a certain achievement of maximum economic targets.

EAST GERMANY

Economic Briefs

It is clear from measurements of high-frequency conductance, the intermediate frequency phase resistance, and the total noise count that the semi-conductor diodes produced by VEB WBN in Teltow, in comparison to the Soviet diodes examined, showed poorer characteristics and also an insufficient stability of data. A comparison of the measured noise counts of a mixing stage in the tubular conductor and/or microstrip technique gave for the latter somewhat more unfavorable values, which fact is attributable to the greater high-frequency loss in the accommodating connection elements as a consequence of the higher transformation ratios.

(Nachrichtentechnik, Vol X, No 3, March 1960, Berlin, page 115; CSO: 4124-N/3)

- END -