

JPRS 70017

25 October 1977

TRANSLATIONS ON USSR SCIENCE AND TECHNOLOGY
BIOMEDICAL SCIENCES

No. 12

**Reproduced From
Best Available Copy**

U. S. JOINT PUBLICATIONS RESEARCH SERVICE

DISTRIBUTION STATEMENT A
Approved for Public Release
Distribution Unlimited

20000315 081

NOTE

JPRS publications contain information primarily from foreign newspapers, periodicals and books, but also from news agency transmissions and broadcasts. Materials from foreign-language sources are translated; those from English-language sources are transcribed or reprinted, with the original phrasing and other characteristics retained.

Headlines, editorial reports, and material enclosed in brackets [] are supplied by JPRS. Processing indicators such as [Text] or [Excerpt] in the first line of each item, or following the last line of a brief, indicate how the original information was processed. Where no processing indicator is given, the information was summarized or extracted.

Unfamiliar names rendered phonetically or transliterated are enclosed in parentheses. Words or names preceded by a question mark and enclosed in parentheses were not clear in the original but have been supplied as appropriate in context. Other unattributed parenthetical notes within the body of an item originate with the source. Times within items are as given by source.

The contents of this publication in no way represent the policies, views or attitudes of the U.S. Government.

PROCUREMENT OF PUBLICATIONS

JPRS publications may be ordered from the National Technical Information Service, Springfield, Virginia 22151. In ordering, it is recommended that the JPRS number, title, date and author, if applicable, of publication be cited.

Current JPRS publications are announced in Government Reports Announcements issued semi-monthly by the National Technical Information Service, and are listed in the Monthly Catalog of U.S. Government Publications issued by the Superintendent of Documents, U.S. Government Printing Office, Washington, D.C. 20402.

Indexes to this report (by keyword, author, personal names, title and series) are available through Bell & Howell, Old Mansfield Road, Wooster, Ohio, 44691.

Correspondence pertaining to matters other than procurement may be addressed to Joint Publications Research Service, 1000 North Glebe Road, Arlington, Virginia 22201.

BIBLIOGRAPHIC DATA SHEET		1. Report No. JPRS 70017	2.	3. Recipient's Accession No.
4. Title and Subtitle TRANSLATIONS ON USSR SCIENCE AND TECHNOLOGY BIOMEDICAL SCIENCES No. 12			5. Report Date 25 October 1977	6.
7. Author(s)			8. Performing Organization Rept. No.	
9. Performing Organization Name and Address Joint Publications Research Service 1000 North Glebe Road Arlington, Virginia 22201			10. Project/Task/Work Unit No.	
			11. Contract/Grant No.	
12. Sponsoring Organization Name and Address As above			13. Type of Report & Period Covered	
			14.	
15. Supplementary Notes				
16. Abstracts The report contains information on aerospace medicine, agrotechnology, bionics and bioacoustics, biochemistry, biophysics, environmental and ecological problems, food technology, microbiology, epidemiology and immunology, marine biology, military medicine, physiology, public health, toxicology, radiobiology, veterinary medicine, behavioral science, human engineering, psychology, psychiatry and related fields, and scientists and scientific organizations in biomedical fields.				
17. Key Words and Document Analysis. 17a. Descriptors				
USSR Aerospace Medicine Agrotechnology Biology Botany Epidemiology/Immunology Human Engineering Marine Biology Medicine Microbiology Physiology Psychology/Psychiatry Public Health Radiobiology Toxicology Veterinary Medicine				
17b. Identifiers (Open-Ended Terms)				
17c. COSATI Field/Group 2, 5E, 5J, 6, 8A				
18. Availability Statement Unlimited Availability Sold by NTIS Springfield, Virginia 22151			19. Security Class (This Report) UNCLASSIFIED	21. No. of Pages 48
			20. Security Class (This Page) UNCLASSIFIED	22. Price

TRANSLATIONS ON USSR SCIENCE AND TECHNOLOGY
BIOMEDICAL SCIENCES

No. 12

CONTENTS

PAGE

NEUROSURGERY

- Ultrasonic Trepanation of the Skull
(M. V. Gromov, et al.; VOPROSY NEYROKHIRURGII IMENI N.N.
BURDENKO, No 4, 1977) 1

PUBLIC HEALTH

- Tasks Prospects for Standardization in Areas of Noise Vibration
(G. A. Suvorov; GIGIYENA TRUDA I PROFESSIONAL'NYYE
ZABOLEVANIYA, No 9, 1977) 7
- Materials for Establishing Standards of Vibration Sensitivity
(L. Ye Milkov, et al.; GIGIYENA TRUDA I PROFESSIONAL'NYYE
ZABOLEVANIYA, No 9, 1977) 11
- Occupational Selection of Medical Personnel for Work in the
Pressure Operating Room
(V. F. Kirillov, et al.; GIGIYENA TRUDA I PROFESSIONAL'NYYE
ZABOLEVANIYA, No 9, 1977) 18
- Some Health Indices for Construction Workers of Industrial
Enterprises in Moscow Oblast
(L. M. Mal'tseva, et al.; ZDRAVOOKHRANENIYE ROSSIYSKOY
FEDERATSII, No 8, 1977) 24
- Injury Not Associated With Work Among Workers of Industrial
Enterprises
(S. Ya. Freydlin, et al.; ZDRAVOOKHRANENIYE ROSSIYSKOY
FEDERATSII, No 8, 1977) 27
- Integrated Analysis of the Health of Workers in Some Shops of
the Lakokraska Association
(V. V. Yemel'yanov; ZDRAVOOKHRANENIYE ROSSIYSKOY
FEDERATSII, No 8, 1977) 34

CONTENTS (Continued)

Page

SCIENTISTS AND SCIENTIFIC ORGANIZATIONS

14th Scientific Session on the Chemistry and Technology of
Organic Sulfur Compounds and Sulfur Crude Oil
(A. Skorova; IZVESTIYA AKADEMII NAUK LATVIYSKOY SSR,
1977)

38

ULTRASONIC TREPANATION OF THE SKULL

Moscow VOPROSY NEYROKHIRURGII IMENI N. N. BURDENKO in Russian No 4, 1977
pp 36-39

[Article by M. V. Gromov, V. I. Loshchilov, I. A. Taran, V. P. Denisov, and G. G. Grishunov, Department of Traumatology, Orthopedics, and Military Field Surgery (Director--Prof M. V. Gromov), Moscow Medical Institute No 2 imeni N. I. Pirogov, and the Study Group on Application of Ultrasound and Other Forms of Energy in Surgery (Director--Prof V. I. Loshchilov), Machines and Welding Process Automation Department, Moscow Higher Technical School imeni N. E. Bauman]

[Text] Resectional trepanation of the skull is often performed today in neurosurgery in cases of depressed fractures of the cranial vault and intracranial hematomas. Mechanical tools are used as a rule--braces with cutters of various design, cutting pliers, and saws, which require considerable physical effort on the part of the surgeon during surgery and make quick, nontraumatic surgery impossible.

The electric and pneumatic surgical apparatus that has been suggested for trepanation of the skull (2,4,5,etc.) has not enjoyed extensive application due to the cumbersome and laboriousness of the work and the traumatic nature of the surgery.

In 1964-1972 M. V. Volkov, V. A. Polyakov, G. G. Chemyanov, V. I. Petrov, G. A. Nikolayev, V. I. Loshchilov, and V. P. Lebedev developed and introduced to clinical practice a new surgical method for dissecting and joining biological tissues by means of low frequency ultrasonic instruments. This method makes it possible to dissect various tissues with less trauma and with a pronounced hemostatic effect.

The first experiments with and clinical tests on the ultrasonic skull trepanation method were performed by V. A. Polyakov, V. I. Loshchilov, and V. P. Denisov at the Department of Traumatology of the Central Institute for the Advanced Training of Physicians in 1971-1972.

There are sporadic reports on use of ultrasonic tools in skull trepanation in the available literature (1,6,9-11).

Materials and Methods

Ultrasonic tools used up until now for trepanation of the skull are inconvenient, and their use is associated with significant physical effort. The goal of our work was to improve ultrasonic trepanation of the skull and create a special semiautomatic device for ultrasonic trepanation of the skull, the UZT-1. The device outfit includes an ultrasonic "pistol" with a set of cylindrical hollow trepans from 8 to 30 mm in diameter, an ultrasound generator with a built-in direct current power source (27 volts), and two acoustic units with a set of ultrasonic saws and chisels used with the URSK-7N device.

The ultrasonic "pistol" (see figure) consists of a micromotor with a built-in reduction gear (1), an ultrasonic energy feed system consisting of a commutator and brush holders (2), an acoustic unit (3), a handle with a button turning the ultrasound and electric motor on and off (4), a housing (5), a restricting device (6), and a trepan (7). All of its parts are housed, insuring the safety of maintenance personnel.

The oscillation amplitude of the trepan is 40-50 μ , the frequency of ultrasonic oscillations is 26.5 kHz, the rpm of the trepan is from 100 to 400, and the weight of the ultrasonic "pistol" is 2 kg. The device is outfitted with a remote control system making it possible to turn it on by pressing a button in the handle of the ultrasonic "pistol."

There are two plug connections for two acoustic units on the back side of the panel of the ultrasound generator. An ultrasonic saw and chisel are used with these units to saw out the osteoperiosteal panniculus and secure it in place again by ultrasonic welding during osteoplastic trepanation of the skull.

The ultrasonic "pistol" together with its set of trepans and acoustic units, and the ultrasonic saws and chisels are sterilized in a special chamber for 30 minutes by paraform vapor. The ultrasonic "pistol" has a restricting device with a spring catch, permitting smooth adjustment of the depth to which the trepan is submerged. This precludes the need for suspending the "pistol" by hand.

The trepan sinks with practically no physical effort due to the weight of the ultrasonic "pistol." The surgeon can easily hold this "pistol" secure perpendicular to the bone area subjected to trepanation with one hand.

The depth to which the trepan sinks is restricted by a special device which stops the trepan as soon as it drills through the bone. The moment this occurs can also be determined easily from change in the intensity and pitch of the sound and from the feel of the tool as the trepan passes through

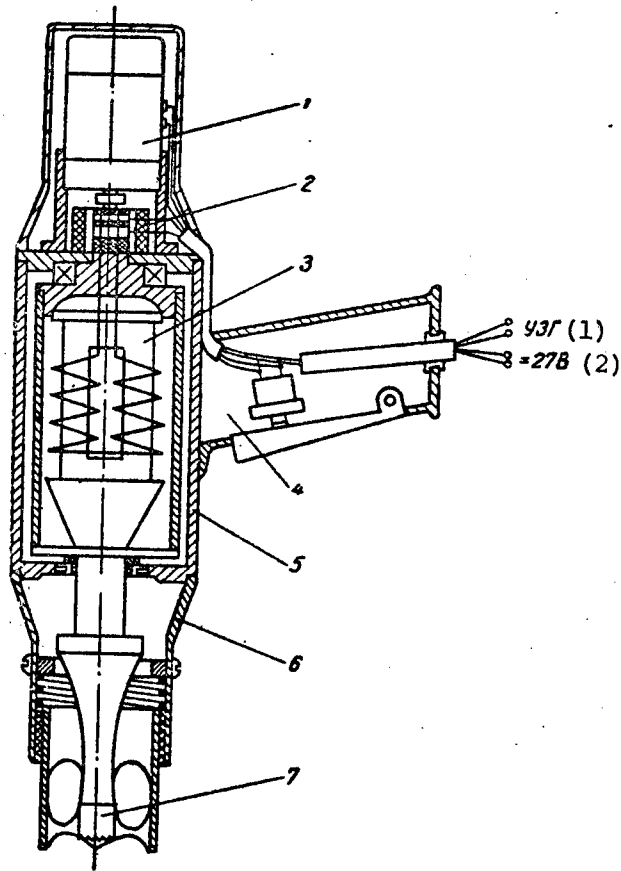

Diagram of an Ultrasonic "Pistol" for Trepanation of the Skull.
Explanation in Text.

Key:

1. Ultrasound generator 2. 27 volts

the bone. During trepanation of the outer cortical lamina the bone chips are white, while when the trepan passes through the spongy layer of bone the chips become pink. At the moment the trepan passes through the vitreous lamina a specific sound of growing intensity arises. The cut hole forms in 12-18 seconds. The temperature in the zone of ultrasonic trepanation was measured by a thermocouple. It reached $46-38^{\circ}$ 2 mm from the zone of trepanation, and it did not exceed 38° 6 mm away.

Research Results and Discussion

We performed a series of experiments with mongrel rats to reveal the action of low frequency ultrasound on flat bones of the cranium, the dura mater, and brain matter--60 experiments with observation times of 1, 3, 5, 8, 15, 21, 30, and 60 days. We established by pathomorphological analysis that

the zone of death of osteocytes in the margins of the zone of damage caused by a mechanical tool is 1.5-2 times larger than for identical operations using ultrasonic tools. No differences were revealed in the histological structure of the dura mater and brain matter with trepanation using mechanical and ultrasonic tools.

The positive results of the experimental research permitted us to begin ultrasonic trepanation of the skull in the clinic. The UZT-1 was used in 78 operations between 1974 and the present at the Clinic of Traumatology, Orthopedics, and Military Field Surgery of Moscow Medical Institute No 2 imeni N. I. Pirogov, using the facilities of the City Clinical Hospital No 1 and the Neurotraumatological Department of the Clinical Hospital No 36. Resectional trepanation was performed on 55 patients, and osteoplastic trepanation was performed on 23.

Resectional trepanation of the skull with the ultrasonic "pistol" begins with drilling of a "trepanational" hole with a diameter of 27-30 mm. This makes it possible to establish presence of an epidural hematoma, determine the condition of the dura mater, its appearance, color, tension, pulsation, and vascular hyperemia and, upon subsequent dissection of the dura mater, examine the subdural space with a spatula. When necessary the hole can be widened by conventional means.

In osteoplastic trepanation of the skull we dissected the soft tissues of the head with an arched incision and then, using the ultrasonic "pistol," drilled five to six holes 4-5 cm apart with a diameter of 10-12 mm. We used a high-productivity ultrasonic saw with a tooth angle of 21-25°, developed at the Moscow Higher Technical School imeni N. E. Bauman, to saw out the osteoperiosteal panniculus. A flat plastic guide 8-10 mm wide and 2-3 mm thick was used to protect the dura mater and brain matter from possible damage by the ultrasonic saw. Using an ultrasonic saw of original design we could saw out the osteoperiosteal panniculus at a 60° angle with less trauma and a pronounced hemostatic effect. After the main phase of surgery on brain matter is completed, if there are no contraindications against reimplanation, the osteoperiosteal panniculus and the small bone fragments (five to six) are placed in the bed of the trepanational defect and secured by means of ultrasonic point osteosynthesis at five or six points. For this purpose we used formalin-preserved homologous shavings, which were applied with a spatula to the edge of the trepanational defect and the osteoperiosteal panniculus and wetted with (tsiakrin). The (tsiakrin) was subjected to the action of an ultrasonic chisel for several seconds; in response to the low frequency ultrasonic oscillations the former underwent polymerization and, together with the bone shavings, formed a dense conglomerate which firmly secured the reimplant in place. The surgical wounds were sutured layer by layer, leaving rubber drains in place. When there were contraindications against reimplantation of the osteoperiosteal panniculus the latter was preserved in 0.5 percent formalin solution. Later the preserved autotransplant could be used in initially postponed plastic surgery on the skull following the procedure described above.

In addition to advantages such as reduction of physical effort on the part of the surgeon and achievement of smooth edges on the trepanational hole, ultrasonic trepanation of the skull produces a pronounced hemostatic effect owing to liberation of heat during dissection of the bone tissue, filling of the spongy matter of the bone by microscopic bone chips, and swelling of collagenic fibers.

The soft tissue wounds of 53 of the patients subjected to surgery (out of 78) healed without complications after the initial closure, while the remaining 25 patients died within several days after surgery due to extensive damage to brain matter and various complications on the part of respiratory organs. No pronounced pathological changes were revealed upon histological examination of the bone edges and the dura mater of two patients who had died 1-5 days after severe cerebrocranial injury. Absence of necrosis in the zone of ultrasonic trepanation of the skull could be the result of significant reduction of the rpm of the trepan, as compared to that of pneumatic surgical apparatus, and short exposure time (12-18 seconds).

The experimental research and the initial clinical data permit an assessment of the advantages of ultrasonic trepanation. Use of the ultrasonic device for trepanation of the skull significantly reduces the time of surgery and makes it least traumatic. The surgery is performed without considerable physical effort and with a pronounced hemostatic effect. Subsequent ultrasonic osteosynthesis permits simple, quick, and sufficiently secure reimplantation.

Conclusions

1. Ultrasonic trepanation of the skull is a new atraumatic method helping to reduce the time of surgery.
2. The obtained results permit us to recommend ultrasonic trepanation of the skull for broad introduction into neurosurgical practice.

BIBLIOGRAPHY

1. Boyarkina, I. I., TRUDY TSENTR. IN-TA USOVERSHENSTVOVANIYA VRACHEY, Vol 188, 1975, pp 22-24.
2. Brenshteyn, Ya. I., VOPR. NEYROKHIR., No 4, 1969, pp 53-54.
3. Volkov, M. V., Polyakov, V. A., and Chemyanov, G. G., TRAVMATOL. ORTOPED., No 9, 1972, pp 1-7.
4. Kiselev, V. A., in "Materialy k mezhoblastnoy nauchno-prakticheskoy konferentsii neyrokhirurgov i travmatologov, posvyashchennoy organizatsii neyrokhirurgicheskoy pomoshchi, problemam travmy cherepa i golovnogo mozga i zakrytym povrezhdeniyam pozvonochnika i spinnogo mozga" (Contributions to an Interoblast Scientific-Practical Conference of

Neurosurgeons and Traumatologists Devoted to Organization of Neurosurgical Assistance and to the Problems of Cranial and Brain Injury and Concealed Damage to the Spine and Spinal Cord), Gor'kiy, 1967, pp 154-155.

5. Konovalov, A. N., VOPR. NEYROKHIR., No 1, 1972, pp 56-59.
6. Koshelev, V. N., Slavutskiy, Yu. M., and Belousov, A. D., "Tezisy dokladov 11-go Vsesoyuznogo s"yezda neyrokhirurgov" (Abstracts of Reports of the 11th All-Union Congress of Neurosurgeons), Moscow, 1976, pp 440-441.
7. Loshchilov, V. I., and Denisov, V. P., in "Ul'trazvuk i drugiye vidy energii v khirurgii" (Ultrasound and Other Forms of Energy in Surgery), Issue 2, Moscow, 1974, pp 77-83.
8. Loshchilov, V. I., and Denisov, V. P., in "Ul'trazvuk i drugiye vidy energii v khirurgii," Issue 2, Moscow, 1974, pp 110-113.
9. Ogleznev, K. Ya., Onopchenko, V. P., and Golyanina, I. P., in "Ul'trazvuk v fiziologii i meditsine" (Ultrasound in Physiology and Medicine), Vol 2, Rostov-on-Don, 1972, pp 44-46.
10. Ogleznev, K. Ya., and Onopchenko, V. P., "Tezisy dokladov 11-go Vsesoyuznogo s"yezda neyrokhirurgov," Moscow, 1976, pp 476-478.
11. Polyakov, V. A., and Boyarkina, I. I., "Khirurgicheskoye lecheniye ushibov i dislokatsiy mozga" (Surgical Treatment of Brain Contusions and Dislocations), Moscow, 1974, pp 204-205.

COPYRIGHT: VOPROSY NEYROKHIRURGII, 1977

11004
CSO: 1870

PUBLIC HEALTH

UDC 613,644+628,517:658,516

TASKS PROSPECTS FOR STANDARDIZATION IN AREAS OF NOISE VIBRATION

Moscow GIGIYENA TRUDA I PROFESSIONAL'NYE ZABOLEVANIYA in Russian
No 9, 1977 pp 1-4

[Article by G. A. Suvorov, Moscow, Institute of Labor Hygiene and
Occupational Diseases of the USSR Academy of Medical Sciences]

[Text] Work on standardization, improving the system of standards in the area of noise and vibration, is of both hygienic and substantial socioeconomic importance because noise and vibration are one of the main unfavorable environmental conditions in which millions of people work. In recent years many basic standards have been developed and put into operation and a definite system has taken shape reflecting virtually all aspects of monitoring, evaluating, and combating these unfavorable factors. This requires extensive information and propaganda services with respect to the existing system of standardization.

During the developmental process each standard goes through a series of stages beginning with drawing up technical specifications and a first redaction and ending with ratification and registration of the standard. Supervision of the introduction and observance of a standard is done by local agencies of the Committee for Standards, its scientific research institutes, and the ministries and departments. Where the requirements of a standard are not observed the Committee for Standardization gives orders, in conformity with the right granted to it, to eliminate the violations that have been discovered or it may prohibit delivery of the products.

At the present time there are a number of state standards concerning noise: GOST [State All-Union Standard] 12.1.003-76 "SSBT. Noise. General Safety Requirements," GOST 20445-75 "Buildings and Structures of Industrial Enterprises. Method of Measuring Noise at Work Positions," GOST 15762-70 "Means of Individual Protection Against Noise. Hygienic Requirements," while for ultrasound we have GOST 12.1.001-75 "SSBT. Ultrasound. General Safety Requirements" and for vibration GOST 1770-72 "Hand-Operated Machines. Permissible Vibration Levels,"

GOST 16519-70 "Hand-Operated Machines. Methods of Measuring Vibration Parameters," and GOST 12.4.002-74 "SSBT. Means of Individual Protection of Hands Against Vibration. General Technical Requirements."

Standard GOST 12.103-76 "SSBT. Noise. General Safety Requirements," which was ratified in January 1976, deserves special attention. It presents a classification of noises by the nature of their spectra (broad-band and tonal) and time characteristics (constant and intermittent), give definitions of discontinuous and pulsed noises which vary in time, introduces evaluation criteria, and gives noise standards for work positions in various production facilities based on the "Hygienic Norms No 1004-73." In addition, it presents requirements for the noise characteristics of machinery and methods of measuring noise.

Attention is called to the fact that zones with noise levels greater than 85 decibels should be marked by warnings and the administration must provide workers in these zones with individual antinoise headgear. This GOST was to be put into effect as of 1 January 1977.

The methodology for monitoring and measuring noise at work positions is given in a standard introduced in 1975, GOST G0445-75 "Buildings and Structures of Industrial Enterprises. Method of Measuring Noise at Work Positions." This standard establishes measured and calculated quantities, the method of measuring them, and the procedure for processing and formulating results. Thus, for constant noises the levels of sound pressure in octave bands of frequencies and the sound levels in decibels are measured, while for intermittent noises equivalent sound levels in decibels determined for time intervals of at least 30 minutes are measured and the standard gives a methodology and examples for calculating the equivalent noise level.

The standards mentioned above provided the basis for development of the new construction standards SNiP 19-76 "Protection Against Noise," containing requirements for planning and construction and citing essential acoustic construction measures to combat noise in residential, production, and public buildings.

In the same year the standard GOST 12.1.001-75 "SSBT Ultrasound. General Safety Requirement" was ratified. It establishes permissible values for levels of sound pressure (based on SN [Sanitary Norm] 245-71), the method of monitoring, and requirements and rules for work with devices that produce ultrasound.

Antinoise headgear for protection against noise and ultrasound should be used in conformity with GOST 15762-70 "Means of Individual Protection Against Noise. Hygienic Requirements." Vibration transmitted to the hands and arms is regulated by GOST 17770-72 "Hand-Operated Machines. Permissible Vibration Levels," which is based on sanitary norms No 626-66 while the method of measurement is established by GOST 16519-70 "Hand-Operated Machines. Methods of Measuring Vibration Parameters." Vibrations of a work position for stationary machines are regulated by

SN 245-71, while for self-propelled machines SN 1102-73 controls. Measurements of vibration should be made and monitoring methods used in conformity with GOST 13731-68 "Mechanical Oscillations. General Requirements for Making Measurements" and the standards for specific types of machinery (GOST 16526-70, GOST 16529-70, and others).

Requirements for instruments to measure noise and vibration are controlled by the following standards: GOST 17187-71 "Noise Gauges. General Technical Requirements," GOST 17168-71 "Electrical Octave and Third-Octave Filters. General Technical Requirements," and GOST 12.4.012-75 "SSBT. Means of Measuring and Monitoring Vibration at Work Positions. Technical Requirements."

State standards define the quality of the working environment in all phases from design or manufacture to operation of the production equipment. Standards developed according to sanitary norms establish permissible values for characteristics of the acoustic or vibration field at work positions, which makes it possible to estimate the degree of health safety of the working environment.

Unlike these standards, which regulate characteristics of factors at the work position, standards applied directly to the characteristics of the machines themselves are indexes of the quality of the machines and are monitored in the stage of manufacture of test models.

The importance of such standards is obvious because they provide the basis for acoustic-construction calculations which insure meeting the requirements of sanitary norms for work positions.

For example, GOST 8.055-73 "GSI. Machines. Methodology for Performing Measurements To Determine Noise Characteristics" establishes the noise characteristics of machinery. Similar vibration characteristics (level of oscillatory power in octave bands of frequency radiated to the machine supports) are yet to be developed.

Together these two groups of standards make it possible to regulate hygienic requirements and methods of monitoring them in the stage of manufacturing noisy and high-vibration machinery and using it at the consumer-plants.

Work on standardization in the area of noise and vibration is done by the Institute of Labor Hygiene and Occupational Illnesses of the USSR Academy of Medical Sciences jointly with the Institute for the Protection of Labor of the AUCCTU, the Institute of Construction Physics of USSR Gosstroy, and other institutes and technical organizations. Periodic review of standards makes it possible to continuously refine them. In just the Tenth Five-Year Plan a whole series of standards is to be developed, among which special attention should be given to "Vibration. General Safety Requirements," "Noise. Methods of Measuring Hearing Loss. General Requirements," and others.

The development of socialist economic integration has brought to life effective new forms of cooperation in this area. Standards for not just our country but for the socialist countries are now being developed in the form of a continuation and elaboration of work on standardization as the highest form of introducing hygienic norms and requirements into national economic practice. During the period 1971-1978 various standards will be prepared within the CEMA framework, for example "Vibration. Terms and Definitions," "Hand-Operated Machines. Requirements for Vibration Levels," "Hand-Operated Machines. Methods of Measuring Vibration," as well as others.

There is no question that we are still far from fully resolving numerous questions of hygienic evaluation of production noises and vibrations. In particular, standards must be differentiated with due regard for the nature of the labor and the difficulty and strenuousness of the work in order to protect health and high work capability and create conditions for efficient, high-quality work. This is precisely the challenge which the State Committee for Science and Technology has placed before hygienic institutes in the Tenth Five-Year Plan.

This problem cannot be solved without precisely planned joint work by all scientific research institutes of labor hygiene and occupational illnesses. For this reason the "Noise and Vibration" section of the "Scientific Foundations of Labor Hygiene and Occupational Pathology" problem commission has drawn up a comprehensive program of research toward development of standards for permissible noise levels in jobs with due consideration for the strenuousness and difficulty of the labor and hygienic standards and rules for permissible vibration levels with due regard for the basic types of labor. This program envisions performance of a definite amount of work by all the country's hygienic institutes in definite periods of time. Methodological instructions on conducting the research, with recommendations for the most informative research methods and criteria for evaluating the effect of noise and vibration, have already been drawn up to supplement the program.

Our experience with work on GOST's and standardization shows that it is advisable to use a system of state standardization and labor hygiene to make research methods uniform and improve them and achieve effective introduction of their results into national economic practice.

COPYRIGHT: "Gigiyena truda i professional'nyye zabolevaniya", 1977

11,176
CSO: 1870

MATERIALS FOR ESTABLISHING STANDARDS OF VIBRATION SENSITIVITY

Moscow GIGIYENA TRUDA I PROFESSIONAL'NYYE ZABOLEVANIYA in Russian No 9, 1977 pp 23-27

[Article by L. Ye. Milkov, V. N. Nikol'skiy, N. B. Metlina, B. N. Mitropol'skiy, T. G. Punched, Yu. P. Syromyatnikov, Moscow, Institute of Labor Hygiene and Occupational Diseases of the USSR Academy of Medical Sciences and clinical hospital No 6 of the USSR Ministry of Health]

[Text] The method of measuring vibration sensitivity (pallesthesiometry) has become widespread in practical research largely thanks to the study of industrial vibration on the human organism.

Nonetheless, the literature contains essentially no information on the physiological variations of the thresholds of vibration sensitivity for investigation at different frequencies. Neither are there methodological approaches and requirements for establishing standards for these indexes.

The indexes of vibration sensitivity are usually integral characteristics of the part of the body under investigation. On the one hand, change in vibration sensitivity as an independent type of sensitivity is related to adequate action by vibrations on the specific receptors (vibrissae, sacculi). On the other hand, vibration sensitivity reflects a state of the tactile analyzer studied in a time interval and, like any form of manifestation with some certain meaning, can be described by its own parameters or properties or its function which differs from the function of change in the tactile analyzer. There are now several types of instruments which make it possible to study the thresholds of vibration sensitivity (in decibels) in the basic frequencies.

Among the chief types of domestic instruments are the IVCh-02 vibration sensitivity gauge, the VT-2 portable vibration tester, and the PEM-01 pallesthesiometer. The PEM-01 has a scale of nonstandard frequencies. The limits of measurement of oscillation amplitude go from -10 to +40 decibels (to +30 decibels in the VT instrument), which is entirely sufficient to describe the degree of reduction of vibration sensitivity, specifically for vibration sickness. In addition, the IVCh-02 and

PEM-01 have capabilities for continuous and discontinuous signaling. The frequency and amplitude characteristics of the instruments according to technical certificates are shown in Table 1 below.

Частота, (1) Гц	(2) Амплитуда колебаний при 0, мкм		
	ИВЧ-02 (3)	ПЭМ-01 (4)	ВТ-2 (5)
16	5		
25		12	
32	3		
50		2,6	
63	1,5		1,5
100		0,076	
125	0,2		0,2
150		0,038	
200		0,03	
250	0,15	0,026	0,15
300		0,045	
400		0,05	
500	0,15	0,06	

Table 1. Frequency and Amplitude Characteristics of Instruments According to Technical Specifications.

- Key: 1) Frequency, Hertz;
 2) Amplitude of Oscillations for 0, Microns;
 3) IVCh-02;
 4) PEM-01;
 5) VT-2.

The present report gives results of an investigation of the thresholds of vibration sensitivity in 588 normally healthy individuals. The tests were made with these instruments. The group examined included persons engaged in physical and mental labor in various occupations between the ages of 20 and 50 who had not been subjected to unfavorable factors in the work environment.

In conformity with statistical requirements for compiling norms (for the normal law of distribution of random quantities) certain "outlying" measurements were excluded, which did not have a significant effect in reducing the total number of observations used for final processing of the material. Based on the data obtained, quantities equal to $\bar{X} \pm 2\sigma$ were taken as beyond the limits of physiological variations in the thresholds of vibration sensitivity. The results of our studies are shown in Tables 2, 3, and 4 below which compare the data obtained with the amplitudes of oscillations corresponding to them. Table 2 also shows the frequency of deviations from $\bar{X} \pm 2\sigma$ found in the research subjects.

It turned out that the boundaries of the norms of the threshold of vibration sensitivity were broader for testing on the PEM-01 than figures obtained for the other instruments (the difference between the lower and upper boundaries ranged from 18 to 27 decibels at different frequencies). This difference in the variability of thresholds was associated with design characteristics of the instruments, in particular with the characteristics of the raw data of the amplitudes of fluctuations of the vibration unit (for 0). At the same time, the data obtained from testing using different instruments testified to a drop in vibration sensitivity at low frequencies, which agrees with information in the literature to

Table 2. Thresholds of Vibration Sensitivity in Decibels at Different Frequencies Studied With The IVCh-Oe Instrument.

Частота, Гц (1)	n	D S	Пределы колебаний (2)	$\bar{X} \pm m$	$\pm \sigma$	$\pm 2\sigma$	% вариант в пределах $\bar{X} \pm 2\sigma$ (3)	(4) Пределы $\bar{X} \pm 2\sigma$		P ± m	
								AB (5)	МКМ (6)	снижение (7)	повышение (8)
16	84	D	-8-(+5)	-0,1±0,29	2,7	5,4	95	-5-(+5)	2,5-8,9	4,8±2,3	0±4,5
	84	S	-8-(+4)	0,24±0,27	2,5	5,0	88	-5-(+5)	2,8-8,9	2,4±1,7	0±4,5
32	84	D	-2-(+12)	2,8±0,31	2,9	5,8	99	-3*(+8)	2,1-7,5	0±4,5	1,2±1,2
	84	S	-5-(+10)	2,9±0,33	3,0	6,0	98	-3-(+9)	2,1-8,4	1,2±1,2	1,2±1,2
63	84	D	1-(+16)	6,0±0,33	3,0	6,0	93	0-(+12)	1,5-6,0	0±4,5	7,1±2,8
	84	S	0-(+16)	5,8±0,33	3,0	6,0	99	0-(+12)	1,5-6,0	0±4,5	1,2±1,2
125	82	D	2-(+19)	9,3±0,38	3,5	7,0	88	2-(+16)	0,25-1,26	0±4,6	12,2±3,6
	82	S	1-(+18)	8,8±0,38	3,5	7,0	94	2-(+16)	0,25-1,26	3,7±2,1	2,4±1,7
250	79	D	3-(+19)	10,7±0,37	3,3	6,6	84	4-(+17)	0,24-1,06	8,3±3,0	8,0±3,0
	81	S	4-(+19)	10,9±0,34	3,1	6,2	80	5-(+17)	0,27-1,06	6,2±2,7	13,6±3,6

Key: n — Number of Test Subjects;

\bar{X} — Mean Arithmetic Value;

m — Mean Error of Mean Arithmetic Value and Percentage;

σ — Mean Quadratic Deviation;

P — Frequency of Deviations (in Percentage) from Limits Equal to $\bar{X} \pm 2\sigma$;

D — Right;

S — Left;

* — Mathematical Assumption.

(1) Frequency, Hertz;

(2) Limits of Fluctuations;

(3) Percentage of Variant Within Limits $\bar{X} \pm 2\sigma$

(4) Limits $\bar{X} \pm 2\sigma$

(5) Decibels

(6) Microns

(7) Decrease

(8) Increase

Table 3. Thresholds of Vibration Sensitivity in Decibels at Different Frequencies for Testing Using the PEM-01 Instrument.

Частота, Гц (1)	n	Пределы колебаний (2)	$\bar{X} \pm m$	$\pm \sigma$	$\pm 2\sigma$	(3) Пределы $\bar{X} \pm 2\sigma$	
						АВ (4)	МММ (5)
25	401	-6-(+24)	9,4±0,25	5,0	10,0	-1-(+19)	10,7-106,9
50	401	-8-(+29)	10,3±0,30	6,0	12,0	-2-(+22)	2,1-32,6
100	401	-10-(+30)	7,7±0,34	6,5	13,6	-6-(+21)	0,04-0,85
150	401	-10-(+22)	3,1±0,27	5,4	10,8	-8-(+14)	0,015-0,19
200	401	-10-(+18)	1,8±0,24	4,8	9,6	-8-(+11)	0,012-0,11
250	401	-10-(+18)	1,9±0,24	4,8	9,6	-8-(+12)	0,010-0,10
300	401	-10-(+17)	0±0,23	4,6	9,2	-9-(+9)	0,016-0,13
400	401	-10-(+19)	0,8±0,24	4,8	9,6	-9-(+10)	0,018-0,16
500	401	-10-(+18)	1,5±0,24	4,8	9,6	-8-(+11)	0,024-0,21

Key [to both Table 3 and Table 4]

- 1) Frequency, Hertz;
- 2) Limits of Fluctuations
- 3) Limits $\bar{X} \pm 2\sigma$
- 4) Decibels;
- 5) Microns

Table 4. Thresholds of Vibration Sensitivity in Decibels at Different Frequencies for Testing Using the VT-2 Instrument.

Частота, Гц (1)	n	Пределы колебаний (2)	$\bar{X} \pm m$	$\pm \sigma$	$\pm 2\sigma$	(3) Пределы $\bar{X} \pm 2\sigma$ *	
						АВ (4)	МММ (5)
63	103	-5-(+5)	-2,3±0,20	2,0	4,0	-5-(0)	0,84-1,5
125	102	-5-(+10)	-1,2±0,29	2,9	5,8	-5-(+5)	0,11±0,36
250	102	-5-(+10)	+1,8±0,29	2,9	5,8	-4-(+10)	0,08±0,47

* The scale division of amplitudes of fluctuations of the instrument is 5 decibels, which was reflected in threshold fluctuations within limits that are multiples of 5; the limits of fluctuations of thresholds $\bar{X} \pm 2\sigma$ are given with assumptions.

the effect that the greatest sensitivity to vibration is observed in the frequency range 100-300 Hertz while sensitivity drops to the left and right of this range (Ye. Ts. Andreyeva-Galanina; I. K. Razumov and co-authors; A. I. Vozzhova and V. K. Zakharov, and others).

It should be noted that most authors (A. I. Vozzhova; Pearson, and others) believe that a drop in vibration sensitivity in healthy people begins at the age of 50 or even 60. T. M. Radzyukevich and A. M. Mikulinskiy found a genuine increase in average values of the vibration threshold for high frequencies at an earlier age (from the age of 40) which, in their opinion makes it necessary to introduce age corrections in testing vibration sensitivity.

Based on our research the upward shift of the threshold in the 40-49 age bracket was slight (1-3 decibels at different frequencies) and we did not take it into account in drawing up norms. No sex-dependent differences in the values of thresholds of vibration sensitivity were found, which also conforms to the literature. Furthermore, the literature does not indicate any significant differences which would be evidence of asymmetry in the indexes of the right and left hands. We did not discover asymmetry in the threshold values either.

Thus, our research enabled us to determine the limits of the physiological variations of thresholds of vibration sensitivity. They proved different for each type of instrument, but the direction of changes characterizing amplitude-frequency ratios was close. Moreover, our research showed that for practical purposes, for example diagnosing vibration sickness, it is sufficient to restrict the test to one of the low frequencies (16 or 25 Hertz) and one of the high ones (250).

The research methodology is fairly well known. Vibration sensitivity is tested on the second, third, or fourth finger of the hands. The subject touches the unguis phalynx of the palmar surface of the finger to the vibration transmitter (vibrator). First the subject is familiarized with the feeling of obvious vibration. Then the threshold is determined in an ascending direction, in other words from the absence of a sensation to the first appearance of a scarcely noticeable vibration. According to instructions the response is given in words or by pressing a signal button. Where the signal is fed continuously the correctness of a response may be checked by interrupting the signal; in the opposite case the reverse procedure is possible. The minimum instrument reading at which the subject begins to feel vibration is considered the threshold. The measurement is made three times and the mean arithmetic value of the three measurements is taken as the threshold.

It should be noted that the literature contains a description of a methodological procedure where the threshold is measured three times in an ascending direction and three times in a descending direction. While not denying the possibility of using this method for special purposes, we cannot recommend it for testing the vibration threshold because by removing adaptational shifts, it artificially decreases the normal boundaries.

It is commonly known that many factors affect the magnitude of the threshold of vibration sensitivity (cooling, previous physical load, uncomfortable posture of the test subject, the force with which the finger is pressed against the vibrator, and others). The contact between the finger and the vibrator should be light; it is recommended that the finger be removed from the vibrator after each measurement to avoid fatigue.

The tests are made in a quiet room at a temperature of 18-22 degrees C. The subject's hands must be dry. Persons coming for testing during the cold season of the year need to adapt beforehand. In cases where the sound associated with the generation of high levels of vibration is audible it is recommended that devices such as earmuffs, inserts, cotton wads, and others be used. The subject must not see the instrument console and doctor's manipulations.

It is common knowledge that vibration sensitivity changes in the course of the day, and therefore to receive more accurate data from large-scale measurements it is advisable to make tests at a definite time of the day, ideally before the start of work.

Our research has shown that the magnitude of the thresholds of vibration sensitivity influenced by the area of the vibrator, the speed of increase and shape of the vibration signal, and other design characteristics; this should be taken into account when comparing results obtained from instruments of different design. Moreover, significant deviations in amplitude from those indicated in the technical specifications are possible for pallesthesiometers of the same design. In view of this, the amplitudes of the pallesthesiometer must be measured before use and periodically during use. If an instrument check is not possible it is advisable to calibrate the instrument physiologically by periodically determining the thresholds in healthy young people for comparison with earlier indexes from the same instrument. This will insure that correct research results are obtained.

BIBLIOGRAPHY

1. Andreyeva-Galanina, Ye. Ts., TRUDY LENINGRADSK. NAUCHNO-ISSLED. IN-TA GIGIYENY TRUDA I PROFZABOLEVANIY, Leningrad, 1947, Vol 10, Part 2, pp 112-122.
2. Vozhzhova, A. I., and Zakharov, V. K., "Zashchita ot Shuma i Vibratsii na Sovremennykh Sredstvakh Transporta" [Protection Against Noise and Vibration in Contemporary Means of Transportation], Leningrad, 1968.
3. Radzyukevich, T. M., and Mikulinskiy, A. M. GIG. TRUDA, 1972, No 7, pp 16-20.
4. Razumov, I. K., Denisov, E. I., Malinskaya, N. N., et al., Ibid., No 5, pp 3-9.

5. Pearson, A., cited from Andreyeva-Galanina, Ye. Ts., "Vibratsiya i Yeye Znachenije v Gigiyene Truda" [Vibration and Its Importance in Labor Hygiene], Leningrad, 1956.

COPYRIGHT: "Gigiyena truda i professional'nyye zbolevaniya", 1977

11,176

CSO: 1801

UDC 617-089.52-051:658:311.44

OCCUPATIONAL SELECTION OF MEDICAL PERSONNEL FOR WORK IN THE PRESSURE OPERATING ROOM

Moscow GIGIYENA TRUDA I PROFESSIONAL'NYYE ZABOLEVANIYA in Russian
No 9, 1977 pp 28-31

[Article by V. F. Kirillov, L. A. Bokeriya, V. Ye. Malikov, A. A. Orlova, and G. V. Snegova, Moscow, Institute of Cardiovascular Surgery imeni A. N. Bakulev of the USSR Academy of Medical Sciences, First Moscow Medical Institute imeni I. M. Sechenov]

[Text] The problem of occupational selection of personnel for work in medical hyperbaric chambers is by no means resolved. Often the most highly qualified specialists are among the persons not permitted to work at increased pressure (Meijne; Ledingham). To say nothing of the moral aspect, the unsuitability of the specialists for work in a pressure chamber may, in the opinion of V. I. Burakovskiy and L. A. Bokeriya, be a factor which hinders the introduction of this method at a particular institution. The question is even put in this way: certain young specialists must be specially selected for hyperbaric medicine and immediately trained to work in hyperbaric chambers. Such a formulation of the question seems extremely debatable at the present time, while this problem is in its formative stage.

Work under conditions of increased barometric pressure belongs in that domain of human occupational activity which, owing to the unusual nature of the conditions and especially great responsibility, make increased demands not only on a person's health but also individual psychophysiological characteristics.

No country in the world has special requirements for selecting people to work in medical pressure chambers. The requirements for divers and caisson workers are applied to them. Naturally, when the question is formulated in this way, especially if one takes the rules of diver work, not more than 20 percent of qualified medical personnel will meet the requirements.

In view of the prospect that there will be development of therapeutic methods for different illnesses using hyperbaric oxygenation and a significant group of medical workers will be involved in this type of work, it is critically necessary to work out a list of contraindications (B. V. Petrovskiy and S. N. Yefuni). There is no doubt that in developing this list one should begin from the positive and effective experience accumulated in occupational selection of divers and caisson workers (Saltzman).

It is perfectly obvious that a certain compromise is necessary in selecting people to work in medical barochambers (Bond). We also feel that some of the health requirements made of divers and caisson workers can be less rigid for medical personnel if there is continuous observation of the health of those who show some deviations from the norm. At the same time, it must be acknowledged that such contraindications as emphysema of the lungs, chronic inflammatory processes of the accessory sinuses of the nose and eustachian tube, hypertonic illness, and stable deformations of the bone-joint apparatus should preserve their absolute value, for the degree of potential danger of the development of decompression disorders and other complications is extremely high with these forms of pathology.

During preliminary preventive examination of doctors and middle-level medical personnel special attention should be directed to the medical history. Special caution must be shown with respect to people who have suffered pneumonia, tuberculosis, and other lung diseases. The presence of a bullous emphysema, bronchiectases, and other residual cavities in the lungs may cause this organ to rupture during compression (Anderson and co-authors; Ciocatto). For this reason I. P. Berezin and N. N. Shchupakov as well as Ledingham point out the absolute necessity of X-raying the thorax and taking various functional tests of breathing for all persons newly entering work in hyperbaric chambers.

In occupational selection the condition of the cardiovascular system should be assigned great importance because it is in the blood circulatory system that gas bubbles form and are transported and the basic processes of saturation and desaturation of the organism are played out. Persons with illnesses such as hypertonic illness and hypotonia and a propensity for vascular spasms cannot be permitted to work in barochambers, in the opinion of Ciocatto.

Work under conditions of increased barometric pressure also imposes a high degree of individual responsibility on each worker. Violation of safety rules can in certain cases have grave consequences for the health of the worker himself and those around him. It cannot be forgotten that working conditions in a barochamber are quite unique and difficult.

As we have already noted above, the presence of acute or chronic pathological states of the accessory sinuses of the nose and middle ear are an absolute contraindication for work in medical barochambers. To

identify relatively symptom-free forms of these illnesses fluorographic tests of the accessory sinuses of the nose should be made in addition to careful otolaryngological examination. Conducting a test compression also produces good results in this respect (Ya. N. Krol and L. A. Kudel'skiy; V. I. Burakovskiy and L. A. Bokeriya; Ledingham).

Among those authorized to work there may be people with greater individual sensitivity to the action of high partial pressures of oxygen. This is good reason to raise the question of a special examination. In the opinion of G. L. Zal'tsman and co-authors, analysis of the fields of peripheral vision may be one technique.

Restrictions on admission to work should be applied to persons with reduced acuteness of vision. This is because a spasm of the blood vessels of the retina develops when pure oxygen is breathed. Ciocatto also believes that increased barometric air pressure may be the cause of detachment of the retina. V. I. Burakovskiy and L. A. Bokeriya believe that the findings of an objective examination of the ocular fundus should provide the basis for admitting persons with lowered acuteness of vision into the barochamber. If such an examination reveals no pathological changes the medical worker may be authorized to work under pressure. But two additional restrictions are introduced for such workers. For one, they are allowed into the barochamber at intervals of at least three days and under pressures not greater than two atmospheres. For two, they cannot work under pressure for more than 90 minutes, and as a result they do not have to breathe oxygen during decompression.

The question of an age qualification for persons working in medical barochambers has not been decided yet. The requirements made of divers and caisson workers are applied to medical workers. In Italy persons working under pressure cannot be more than 38 years old (Ciocatto). According to the rules in effect in our country, men between the ages 18 and 50 are permitted to do physical work under compressed air pressures of not more than 1.9 atmospheres, while the age range for pressures of greater than 1.9 atmospheres is 18-45 years (L. S. Rozanov). There is no question that the mechanical application of these limitations to workers in medical barochambers would hinder the further development of the method and prevent qualified specialists from working in this field. We must agree with Boerema and Meijne that it is possible to increase the age qualifications for persons working in hyperbaric chambers. In our view, the ceiling may be set at 55 years of age with good health and constant medical monitoring.

The question of allowing women to work under increased pressure remains open. The main objection is the view that they are more subject to caisson sickness because they have a thicker layer of fat tissue where nitrogen can accumulate than men have. In our view, women can work in barochambers on an equal basis with men, with the exception of some cases: the presence of acute and chronic illnesses of the female sexual organs, propensity for hemorrhages, menstrual period, lactation, and pregnancy.

The preliminary medical examination is a crucial element in occupational selection. However, medical observation of personnel should continue for the entire period of work under increased pressure. This observation should be aimed at detecting the first unfavorable changes in health which may hinder further work in the barochamber. To achieve this, in our opinion, periodic medical examinations should be conducted once a year and involve a broad range of specialists: internists, neuropathologists, otolaryngologists, surgeons, gynecologists, and oculists. X-ray examination of the joints (shoulder, knee, coxofemoral), taking an electrocardiogram, and making a full clinical analysis of blood and urine are mandatory conditions.

Based on the above we have developed a list of contraindications for practical medical selection and recertification of personnel working in pressure operating rooms. Recalling that there is a certain tentativeness to this list, however, we consider it necessary to point out that it can be used as a working hypothesis with later scientific substantiation and refinement of certain of its points.

The list of medical contraindications that prohibit admission to work in departments of laboratories of hyperbaric oxygenation are the following:

1. Marked bodily deficiencies which prevent work in the particular occupation.
2. Chronic illnesses of the upper respiratory tract and lungs which impair the breathing function. Active forms of pulmonary tuberculosis.
3. Organic illnesses of the heart regardless of the degree of compensation for them.
4. Hypertonic disease in stages II-III, stable vascular hypotonia.
5. Marked vegetative-vascular dystonia.
6. Marked, widespread varicosity, endarteritis.
7. Hemorrhage (bleeding with frequent incarcerations).
8. Chronic illnesses of the abdominal organs with marked changes in their function (ulcer of the stomach and duodenum, ulcerative colitis, illnesses of the kidneys and bladder, and so on).
9. Hepatitis.
10. All types of hernias.
11. Illnesses of the endocrine glands with stable impairment of function.
12. Chronic illnesses of the bones and joints.
13. Chronic neuritises and radiculitises.

14. Blood diseases, hemorrhagic diathesis
15. Organic illnesses of the central nervous system, including epilepsy
16. Psychological illnesses (even in the remission stage), psychopathy
17. Convulsive seizures of any origin
18. Marked neuroses (hysteria, neurasthenia, psychasthenia)
19. Chronic purulent otitis, atrophic scars of the tympanic membrane, chronic eustachitises
20. Impairment of the function of the vestibular apparatus
21. Acuteness of vision less than 0.8 in the better eye and less than 0.5 in the worse (without correction)
22. Any eye illness leading to stable impairment of the visual function
23. Periods of pregnancy, lactation, and menstruation
24. Impairments of the ovulation-menstruation cycle
25. Chronic gynecological illnesses
26. Increased sensitivity to breathing pure oxygen
27. Age of less than 18 or more than 55.

BIBLIOGRAPHY

1. Burakovskiy, V. I., and Bokeriya, L. G. "Giperbaricheskaya Oksigenatsiya v Serdechno-Sosudistoy Khirurgii" [Hyperbaric Oxygenation in Cardiovascular Surgery], Moscow, 1974.
2. Berezin, I. P., and Shchupakov, N. N., in "Meditsinskaya Tekhnika. Nauchnyy Obzor" [Medical Technology. Scientific Survey], No 6, Moscow, 1968, pp 44-60.
3. Zal'tsman, G. L., Zinov'yeva, I. D., and Kumanichkin, S. D., in "Funktsii Organizma v Izmenennoy Gazovoy Srede" [Organism Functions in an Altered Gas Medium], Moscow-Leningrad, 1964.
4. Krol, Ya. M., and Kudel'skiy, L. A. VOYEN.-MED. ZH. 1960, No 3, pp 36-38.
5. Petrovskiy, B. V., and Yefuni, S. N., in "Primeneniye Kisloroda pod Povyshennym Davleniyem v Meditsine" [The Use of Oxygen under Increased Pressure in Medicine], Moscow, 1971, pp 3-6.

6. Rozanov, L. S., "Rukovodstvo po Gigiyene Truda" [Manual on Labor Hygiene], Vol 1, Moscow, 1965.
7. Anderson, B. J., Whalen, R. E., and Saltzman, H. A. JAMA, 1964, Vol 90, pp 1043-1045.
8. Boerema, I. PROC. ROY. SOC. MED., 1964, Vol 57, p 817.
9. Bond, G. F. in "Fundamentals of Hyperbaric Medicine," Washington, 1966, p 141.
10. Ibid., pp 144-148.
11. Ciocatto, E. MINERVA ANEST., 1967, Vol 33, pp 506-535.
12. Duffi, H., CANAD. MED. ASS., 1964, Vol 91, pp 1051-1055.
13. Ledingham, I., and Davidson, I. K., BRIT. MED. J., 1969, Vol 3, pp 324-327.
14. Meijne, N. G., in "Clinical Application of Hyperbaric Oxygen," Amsterdam, 1964, pp 261-266.
15. Workman, R. D., in "Fundamentals..." op. cit., pp 110-127.

COPYRIGHT: "Gigiyena truda i professional'nyye zabolevaniya", 1977

11,176
CSO: 1870

UDC 616-057:69(470.311)

SOME HEALTH INDICES FOR CONSTRUCTION WORKERS OF INDUSTRIAL ENTERPRISES IN
MOSCOW OBLAST

Moscow ZDRAVOOKHRANENIYE ROSSIYSKOY FEDERATSII in Russian No 8, 1977 pp 20-21

[Article by L. M. Mal'tseva, E. I. Finkel'berg, and L. P. Izvarina, Moscow
Scientific Research Clinical Institute imeni M. F. Vladimirskiy]

[Text] Today, in addition to major housing construction, we are erecting huge industrial enterprises with the participation of large groups of workers with different specialties. The specific working conditions, the territorial separation of the objects being erected, full mechanization, and presence of complex equipment at the construction sites are requiring improvements in organization of medical services for construction workers.

Only a few isolated works have been devoted to the health of workers in civil construction.

Occupational morbidity and temporary incapacitation of construction workers of industrial enterprises in heavy industry have not as yet been illuminated in the literature, though their working conditions have their unique features.

The objective of the present research was to study morbidity involving temporary incapacitation among 500 workers of three construction organizations in the Mosoblstroy-9 Trust participating in construction of the buildings of the Elektrostal' Metallurgical Plant. The morbidity analysis was based on report forms and incapacitation certificates for all workers covering a 3-year period (1972-1974).

Because individual morbidity records were absent we copied 2,730 primary incapacitation certificates. We studied temporary incapacitation in two groups of workers (group 1 consisted of workers in the principal and auxiliary occupations, and group 2 contained engineers, technicians, and office workers).

We should note that men dominate occupations such as carpenters, electric welders, and installers while occupations such as concrete workers are held mostly by women; meanwhile masons are represented by both sexes, with a slightly larger number of men. Among laborers, engineers, technicians, and

office workers, 90 percent were up to 50 years old; about 15 percent of the laborers and about 2 percent of the engineers, technicians, and office workers were up to 20 years old.

Laborers in the principal occupations (concrete workers, masons, installers, electric welders, carpenters) do their work at greater heights in the open, frequently in unfavorable meteorological conditions. Moreover they are subjected to the effects of a number of occupational factors to include, in particular, vibration and dust for concrete workers and masons, and electric welding aerosols for electric welders and installers. The workplace of line engineers and technicians (work superintendents, foremen) is the construction site, and consequently they are also subjected to the effects of a number of unfavorable factors. Medical services are provided to the group of workers under analysis by the city polyclinic on the shop principle.

On comparative analysis of the obtained data we established that about 69 percent of the workers in group 1 and about 76 percent of all workers in group 2 had been ill during the years covered. We should note that 53.6 percent of the workers in group 1 received one incapacitation certificate, 23.6 percent received two, 12.2 percent received three, and 9.7 percent of those falling ill received four or more. These indices were 55, 22.2, 12, and 11.1 percent respectively for group 2. Recurrent cases in group 1 included acute respiratory diseases for 19.4 percent, angina for 5.3 percent, aggravation of chronic diseases of the respiratory organs for 36.3 percent, hypertonic illness for 39.5 percent, cardiac ischemia for 33 percent, diseases of the skeletomuscular systems for 12.7 percent, gastric diseases for 23 percent, and skin infections for 31 percent of the individuals who had suffered the given form of illness. Recurrent cases in group 2 included acute respiratory diseases for 15.2 percent, angina for 20 percent, hypertonic illness for 20 percent, cardiac ischemia for 33.3 percent, diseases of the skeletomuscular system for 7.9 percent, and gastric diseases for 38.3 percent of the persons suffering the given form of illness.

Acute afflictions of the nasopharynx and respiratory organs (angina, respiratory diseases, influenza) are in first place in the morbidity structure, making up 45.7 percent of all cases of incapacitation in group 1 and 55.2 percent in group 2; diseases of the skeletomuscular system are in second place, while third is occupied by diseases of digestive organs (ulcers, gastritis, and diseases of the liver and bile ducts).

Morbidity was higher among laborers as compared to engineers, technicians, and office workers in relation to aggravated chronic diseases of the respiratory organs, skin and subcutaneous infections, injuries at work and at home, and mental disorders.

Laborers in auxiliary occupations exhibit high indices in relation to aggravated chronic diseases of the respiratory organs. The main reason for this is that patients and disabled persons with both general and occupational diseases of the respiratory organs are placed in these jobs by medical control commissions and medical commissions for determination of disability.

Among the causes of initial disability, first place is occupied by diseases of the cardiovascular system (cardiac ischemia, hypertonic illness), followed by malignant tumors.

Thus the highest indices of incapacitation of workers due to aggravation of chronic diseases of the respiratory organs, diseases of the skeletomuscular apparatus, skin and subcutaneous infections, and work injury are associated with a number of unfavorable production factors (various meteorological conditions experienced while working at greater height, heavy physical load, the effects of dust and vibration, skin injury, and so on), which requires improvements of the working conditions and medical education. To prevent illness, workers must be selected carefully and high-quality periodic medical examinations must be conducted.

COPYRIGHT: ZDRAVOOKHRANENIYE RSFSR, 1977

11004
CSO: 1870

UDC 617-001-057.9

INJURY NOT ASSOCIATED WITH WORK AMONG WORKERS OF INDUSTRIAL ENTERPRISES

Moscow ZDRAVOOKHRANENIYE ROSSIYSKOY FEDERATSII in Russian No 8, 1977 pp 21-26

[Article by S. Ya. Freydlin, Ye. N. Vlanskaya, M. V. Kazarezov, N. I. Luzganova, V. V. Ponikovskaya, L. A. Popova, N. M. Tolstyakov, N. I. Filipov, and N. A. Shchukina, Leningrad Institute of Traumatology and Orthopedics imeni R. R. Vreden]

[Text] Injuries have occupied third place among the causes of mortality in the population in recent years, while among people from 20 to 50 years old injuries are the main cause. Among all injuries, more than half (55.6 percent) are not associated with work. Much attention should be devoted to the study of injuries not associated with work in this connection. This article presents the results of an analysis of injuries not associated with work among laborers at eight enterprises of different industrial sectors (metallurgical, machine building, chemical, coal mining, and wood processing). Data on 3,438 cases of injuries not associated with work occurring in 1974 were collected. These enterprises employed 83,261 persons, of whom 54.3 percent were men and 45.7 percent were women. In some industrial sectors this ratio is somewhat different: Chemical industry employed 33.5 percent men and 66.5 percent women, coal mining employed 80.8 percent men and 19.2 percent women, and metallurgy employed 64.8 percent men and 35.2 percent women.

Among these workers, most were 30-49 years old (56.4 percent), with younger persons up to 20 years old (8.1 percent) and persons over 60 years old (3.5 percent) contributing smaller shares.

The index of the frequency of injuries not associated with work was 41.3 on the average, computed per 1,000 workers. This index varied rather noticeably in different sectors--from 62⁰/₀₀ in coal mining industry to 23.6⁰/₀₀ in chemical industry.

We should note that the frequency of injuries not associated with work among men was more than twice greater (58.1⁰/₀₀) than among women (21.3⁰/₀₀). This index is rather high for people from 20 to 29 years old (67.9⁰/₀₀), while in other age groups it is much lower: 31.4⁰/₀₀ for up to 20 years old, 39.4 for 30-39, 34.1 for 40-49, and 25.6⁰/₀₀ for persons over 50 years old.

Out of the total number of recorded injuries not associated with work, 92.1 percent were contributed by laborers, to include 58.6 percent by persons doing heavy physical work, while 4.2 percent were contributed by engineers and technicians and 3.7 percent were contributed by office workers.

Most injuries not associated with work occurred on the street (50.9 percent) and at home (40 percent), with considerably fewer occurring in other places--in yards (4.6 percent), on highways (2.2 percent), in social institutions (1.4 percent), at work (0.6 percent), and in rail transportation (0.3 percent).

The proportion of injuries not associated with work was significantly higher among men than among women: At work--0.7 and 0.3 percent, in the streets--53.6 and 42.2 percent, and on highways--2.4 and 1.2 percent respectively. Meanwhile women experienced a greater proportion of injuries at home than did men--50.5 and 36.7 percent respectively.

We should note that the proportion of street injuries not associated with work was higher among young people up to 20 years old (57.3 percent) than among people over 60 years old (41.5 percent), but injuries at home are of lower frequency for the former (32.7 and 50.8 percent respectively).

Injuries not associated with work are recorded most frequently in summer (28.2 percent) and spring (24.6 percent).

Most injuries not associated with work occur on days off and holidays (19.5 percent), especially among women (20.6 percent), people from 50 to 59 years old (23.8 percent), engineers and technicians (27.2 percent), and office workers (24.4 percent); these are usually injuries on highways (27 percent) and in public places (31.7 percent). Injuries are somewhat less frequent on Monday (15.8 percent), especially among men (16.6 percent), people from 30 to 39 years old (17.3 percent), and laborers (16.4 percent); usually these are injuries in the home (17.5 percent).

Injuries not associated with work are distributed in the following way with respect to hours of the day: From 0800 to 1600 hours--37.1 percent, from 1700 to 2400 hours--56.6 percent, and from 0100 to 0700 hours--6.3 percent. The proportion of injuries recorded at night is somewhat higher for women (7.2 percent) than for men (6.1 percent). This percentage is above average for persons up to 20 years old (9.5), for injuries recorded on Monday (7.8), in January (11.2 percent), in rail transportation (11.1) and on highways (10.2).

Detailed study of the causes and circumstances under which injuries occur acquires decisive significance from the standpoint of preventing injury not associated with work. Our information showed that most injuries not associated with work (42.6 percent) involved falling of the individual; among these, injuries resulting from falling on ice were foremost (14.4 percent), while 6.3 percent of the injuries occurred due to falling from high places. The proportion of these causes is higher among women (48.6 percent), than among men (40.6 percent). Ice involved 18.3 percent of all injuries not associated with work among women, and 13.1 percent among men.

Injuries occurring in fights were second in frequency among the causes of injuries not associated with work (21.1 percent). This index is higher for men (21.9 percent) than women (18.8 percent). Injuries occurring during performance of housework are in third place (20.8 percent), with women experiencing such injuries somewhat more frequently (21.1 percent) than men (20.7 percent). Injuries involving transportation are in fourth place (10.7 percent), with only 0.2 percent involving rail transportation and the remaining 10.5 percent being contributed by urban transportation. Men receive such injuries much more frequently (11.7 percent) than do women (7.4 percent). The remaining 4.8 percent are contributed by injuries resulting from the falling of various objects upon the individuals (3.5 percent) and by bites from pets (1.3 percent).

The structure of the causes of injuries not associated with work varies for people of different ages. The proportion of injuries resulting from falling on ice increases with age: Up to 20 years--7 percent, 20-29 years--12.3 percent, 30-39 years--14.4 percent, 40-49 years--17.2 percent, 50-59 years--18.7 percent, and 60 years and older--26.6 percent.

The same trend is also noted for injuries occurring during the performance of housework, their proportion increasing from 21.6 percent for young people less than 20 years old to 26.6 percent for people over 60 years old. We should note that the proportion of injuries occurring in fights and caused by urban transportation decreases with age (22.5 percent of injuries occurring in fights are suffered by young people up to 20 years old, while 10.9 percent are suffered by elderly people; transportation injuries are 16.4 and 4.6 percent respectively for young and elderly people).

Certain variations in this index can also be noted for people working in different industrial sectors. The average proportion of injuries occurring due to falling on ice is lowest among workers in coal mining industry (8.9 percent). The highest average percentage of injuries (25.7) associated with housework occurs among workers in machine building, while that of injuries occurring in fights (29.7) is contributed by workers in coal mining industry.

The proportion of injuries associated with falling on ice is twice greater among engineers and technicians (26.7 percent), than among laborers (13.8 percent). The proportion of injuries experienced by laborers during the performance of housework (21.2 percent) is higher than among engineers and technicians (19 percent) and office workers (17.2 percent). Laborers contribute twice more than engineers and technicians to the proportion of injuries associated with fights (21.8 percent as opposed to 10.3 percent), and their contribution to transportation injuries is greater (10.7 percent) as compared to office workers (7.6 percent).

Above-average indices are noted on Mondays for injuries not associated with work involving the performance of housework (24.5 percent) and falling from high places (7.1 percent), on Saturdays for falling on ice (16.2 percent), and on Sundays for fights (24.4 percent). The proportion of injuries occurring during housework increases (25.6 percent) in the morning and during

the day (from 0800 to 1600 hours), in fights (27 percent) in the evening (from 1700 to 2400 hours), and in falling on ice (21 percent) at night (from 0100 to 0700 hours).

Among injuries not associated with work but occurring at work, 70 percent are associated with falling of the individual, and 20 percent are associated with the falling of various objects on the victim. Among injuries occurring in the streets, 51.8 percent are due to falling of the victims, with 27.5 percent of the falls caused by ice; 28.6 percent of injuries on the streets occurred in fights. More than half (51.8 percent) of the injuries at home occurred during the performance of various sorts of housework. Fights are the cause of one-fourth of all injuries occurring in various public places.

We know that injuries not associated with work involve alcoholism to a certain degree. Our information showed that 13.1 percent of the victims experienced injuries not associated with work while in a state of alcoholic intoxication. We would have to assume that this number is understated, since injured persons often seek medical assistance only after the signs of alcoholic intoxication disappear. The proportion of persons injured in a state of alcoholic intoxication is many times greater for men (16.2 percent) than women (3.2 percent). This percentage is more than twice higher (14.7) among people from 20 to 39 years old than among the elderly (5.4). It is much higher among workers in wood processing (31.9) and coal mining (18.2) than in other industrial sectors.

The proportion of individuals receiving injury in a state of alcoholic intoxication is much lower among engineers and technicians (5 percent) and office workers (6.5 percent) than among laborers (13.9 percent), and it is much lower for persons injured in the morning (6 percent) as compared to evening (12 percent) and night (12.2 percent). Intoxicated persons contribute a large percentage to injuries on rail transportation (30) and in the streets (16.2). As we would expect, the largest number of injuries received by intoxicated persons (33.4 percent) occurred in fights.

There is a certain amount of interest in the nature and location of injuries in relation to planning traumatological assistance for injuries not associated with work. According to our data contusions and sprains hold first place among injuries not associated with work (41.3 percent), wounds to soft tissues are in second place (24.5 percent), followed by bone fractures (18.4 percent), burns and frostbite (8.8 percent), and dislocations (1 percent). Above-averages are: Metallurgists--contusions and sprains (48.4), machine builders--bone fractures (22.8) and burns (11.3), chemical workers--also bone fractures (29.6), workers in wood processing industry--contusions and sprains (53.5), and workers in coal mining industry--dislocations (2.4).

The dominant injuries among persons falling on ice are contusions and sprains (64.9 percent), bone fractures (27.7 percent), and dislocations (2 percent). There are many wounds (40.1 percent) and burns (34.9 percent) among injuries occurring during the performance of housework, while contusions and sprains

(54.4 percent) and bone fractures (33.9 percent) dominate in cases of falling from high places. The proportion of wounds increases (40.9 percent) among injuries associated with fights, while bone fractures are higher (30.8 percent) in injuries caused by urban transportation.

Injuries not associated with work are distributed as follows with respect to location: Hands--19.8 percent, lower limbs--18.9 percent, head--18.7 percent, upper limbs--14.6 percent, torso--12.3 percent, foot--11.1 percent, numerous locations--2 percent, spine--1.2 percent, and other locations--1.4 percent.

Head injuries are dominated by wounds to soft tissues (31.2 percent), torso injuries are dominated by contusions (53.1 percent), spinal injuries usually involve contusions (67.5 percent) and fractures (27.5 percent), upper limb injuries usually involve dislocations (52 percent), and lower limb injuries usually involve contusions and sprains (54.3 percent) and fractures (20.2 percent).

Our data permitted us to establish the frequency of individual injuries as intensity indices, differentiated with respect to men, women, and different age groups. Injuries occurring more frequently among men than among women included wounds (14.8⁰/₀₀ as opposed to 4.5⁰/₀₀) and limb fractures (10.8⁰/₀₀ as opposed to 3.7⁰/₀₀), while contusions and sprains occurred more frequently among women than among men (8.7⁰/₀₀ as opposed to 2.4⁰/₀₀). Bone fractures (7.4⁰/₀₀ as opposed to 5.7⁰/₀₀) and dislocations (0.3⁰/₀₀ as opposed to 0.1⁰/₀₀) occurred more frequently among people 50 years old and older than among young people up to 20 years old, while the following injuries were more frequent among young people than among the elderly--soft tissue wounds (18.6⁰/₀₀ as opposed to 3.9⁰/₀₀) and contusions (29.4⁰/₀₀ as opposed to 9.0⁰/₀₀).

There is a certain amount of interest in organizing medical assistance to casualties experiencing injuries not associated with work.

Almost half (48.7 percent) of such patients receive first aid at traumatological stations, 33.7 percent receive it at health centers at places of work, 11.8 percent receive it at hospital admissions rooms, 3.2 percent receive it at home, and 2.6 percent receive it on the street. The proportion of those receiving first aid in hospital admissions rooms is higher (20.1 percent) for people injured at night (from 0100 to 0700 hours), while the proportion of persons injured at night and serviced by traumatological stations is below average (41.7 percent). The proportion of those receiving first aid in hospital admissions wards is dramatically higher among persons injured on highways (29.5 percent) and on rail transportation (20 percent), and among victims with bone fractures (17.8 percent) and dislocations (14.7 percent). In relation to dislocations, meanwhile, the proportion of those receiving first aid at traumatological stations increases to 58.8 percent.

Hypothetically, a tremendous number (86 percent) of victims of injuries not associated with work were given first aid by physicians, 10.4 percent were given first aid by secondary medical personnel, 2.7 percent of the victims resorted to self-aid, and 0.9 percent resorted to mutual aid.

The proportion of victims serviced by secondary medical personnel for injuries not associated with work but suffered at work increases to 16.7 percent; the proportion of mutual aid also increases, to 16.7 percent, with a noticeable reduction in the number of persons serviced by physicians, down to 61 percent. The proportion of self-aid increases to 6.7 percent for injuries in yards and while performing housework. The number of persons given assistance by physicians increases considerably for bone fractures (93.4 percent) and dislocations (97.1 percent).

Organization of treatment of the victims of injuries not associated with work is somewhat different. Most of them (89.5 percent) were treated only as outpatients, while only 10.5 percent required hospital treatment. This ratio varies somewhat with respect to injuries of different natures. Among the total number of victims making use of hospital treatment, 6.3 percent had wounds, 6.4 percent had contusions, 15.4 percent had bone fractures, 17.6 percent had dislocations, and 6.7 percent had burns.

The largest numbers of such patients included those with head injuries (25.3 percent), spinal injuries (20 percent), multiple injuries (20 percent), torso injuries (13 percent), and eye injuries (12.5 percent). Relatively few patients with injuries to the hands (2.2 percent), feet (2.9 percent), and upper (8 percent) and lower limbs (6.9 percent) were hospitalized. Among outpatients, most received treatment at the polyclinics of medical-sanitary units (74.1 percent) and at traumatological stations (22.2 percent). The average quantity of outpatient visits per injury was 3.7 percent; naturally the proportion of such visits was greater for bone fractures (5.2 percent) and dislocations (4.6 percent). There were very few such patients at medical-sanitary unit hospitals (1.7 percent), most of them (98.3 percent) being treated at urban hospitals. The average bed time of one patient was 20.1 days; it was 29.5 days for burns and 25.7 days for fractures.

Victims of injuries not associated with work remained in hospitals for therapy for 84.9 bed days per year per 1,000 workers: This index is much greater for men (128.8) than for women (33.1). It was highest for people from 20 to 29 years old (122.5), for workers in coal mining industry (208.5), and for workers in machine building industry (156.3).

It is difficult to compute indices for the number of days of incapacitation due to injuries not associated with work because medical certificates are generally not issued for injuries while in a state of alcoholic intoxication, while in relation to all other injuries not associated with work, they are issued only beginning with the sixth day of incapacitation. Therefore in order to establish the number of days of temporary incapacitation due to injuries not associated with work we had to separately determine calendar

days of incapacitation from medical and hospital certificates. According to our data, medical certificates were issued to 93.6 percent of the victims of injuries not associated with work with an average duration of 6 calendar days, while hospital certificates were issued to only 63.7 percent of the victims, with an average duration of 17.7 calendar days. This index is considerably higher for bone fractures (30.4 days).

The annual time of incapacitation certified by medical certificates is 23.3 days per 100 workers, while the time certified by hospital certificates is 46.5 days. These indices are higher for men (34.5 and 97.7) than for women (9.9 and 26.7) but they are highest for young people from 20 to 29 years old (41 and 62.5) and for workers in coal mining industry (55.7 and 53.1).

All injuries not associated with work which we recorded terminated in recovery, with only one patient suffering a spinal fracture certified disabled.

Thus this information provides a rather complete picture of the incidence of injuries not associated with work among laborers in different industrial sectors.

The efforts of various departments and institutions would be required if we are to prevent injuries not associated with work effectively.

COPYRIGHT: ZDRAVOOKHRANENIYE RSFSR, 1977

11004
CSO: 1870

UDC 614.1:313.13-057:667.6

INTEGRATED ANALYSIS OF THE HEALTH OF WORKERS IN SOME SHOPS OF THE LAKOKRASKA ASSOCIATION

Moscow ZDRAVOOKHRANENIYE ROSSIYSKOY FEDERATSII in Russian No 8, 1977 pp 26-28

[Article by V. V. Yemel'yanov, Department of General Hygiene (Director--Prof G. P. Babanov), Yaroslavl' Medical Institute]

[Text] Modern chemical industry is a complex national economic sector of numerous specialties, producing several tens of thousands of types of products.

Due to scientific-technical progress in this industrial sector, new production processes have been introduced and a number of production operations have been fully mechanized and automated in recent years, which has significantly improved the sanitary-hygienic conditions of work at the enterprises.

However, despite the significant improvements in working conditions, the integrated effects of a number of toxic chemicals are having an unfavorable influence on the health of workers. Intense chemicalization of the country's national economy is unavoidably accompanied by creation of new chemicals, which are often poorly studied and for practical purposes have not been subjected to sanitary-hygienic assessment, and by their introduction into production processes.

Although literature devoted to various aspects of modern paint and varnish industry is rather extensive, few works have been devoted to morbidity and the health of workers involved in manufacture of enamels out of condensation resins. Workers of these shops are continually subjected to the effects of highly concentrated organic solvent vapors (xylol, toluol, acetone, butylacetate, white spirit, butanol, and others) in various combinations, while some workplaces are also affected by pigments, the action of which is diverse and insufficiently analyzed.

Our object of research was two shops in the enamel production operation of the Yaroslavl' Lakokraska Association. The goal of the work was to determine the hygienic parameters of the production environment (gas and dust content, temperature, humidity, production noise level, illumination, ventilation

effectiveness) and to conduct an integrated study on the health of the workers.

The principal research method was a procedure, which we modified, for studying morbidity involving temporary incapacitation developed by N. I. Gavrilov et al. (1969).

Information used in subsequent analysis of morbidity consisted of data on temporary incapacitation copied from incapacitation certificates covering 5 years (1969-1973) and a census of the workers taking account of age, sex, time of work, and occupation; the obtained information was supplemented by the results of an integrated preventive medical examination of the workers by medical specialists (a therapist, a neuropathologist, an otorhinolaryngologist, and a dermatologist) as well as by some information from a social-hygienic survey.

Before presenting the level and nature of morbidity involving temporary incapacitation as determined by the program in depth, we would like to cite some morbidity data from official statistical reports. Thus, during the years of the analysis, morbidity involving temporary incapacitation increased from 125.6 cases per 100 workers in 1969 to 162.9 in 1973 (or from 1,233.0 to 1,611.0 days respectively). It follows from these data that the morbidity indices for the selected shops are not only rather high, exceeding the corresponding indices for the association as a whole and for the entire industrial sector, but also they have a tendency toward growth.

Morbidity analysis in depth was conducted among workers who had worked at the production operation for not less than 5 years.

Given a general morbidity of 131.4 cases and 792.2 days per 100 workers, we can see that diseases of the respiratory organs are highest in frequency (85.4 cases and 394.1 days), followed by diseases of the nervous system and sense organs (8.3 and 59.2) and diseases of digestive organs (6.7 and 64.2). Next, in diminishing frequency, are diseases of the skeletomuscular system, circulatory organs, urogenital organs, and so on.

The relatively high morbidity of women as compared to men is interesting (148.4 cases and 866.8 days as opposed to 93.1 cases and 652.2 days). Morbidity is significantly higher among women in relation to almost all classes of diseases, except for diseases of the nervous system and sense organs, circulatory organs, the skin, and injuries, especially at home.

On comparing morbidity of enamel shop workers with that of laborers and office workers in enterprises of textile industry (B. N. Yemel'yanov, 1965; M. S. Brilliantova, 1964; M. B. Aleksandrova, 1963) we find that morbidity is significantly higher in relation to mental disturbances in women, diseases of respiratory organs in men and women, diseases of urogenital organs in women, diseases of the skeletomuscular system, and some other nosological forms.

If we look at morbidity with respect to age, we would find a trend toward greater morbidity with older age. Thus while in the youngest age group (up to 29 years) the number of cases per 100 workers is 93.3 for men and 80.0 for women, in the 30-39 year group this index is somewhat lower for men (68.5) and higher for women (154.1). In the 40-49 year group the number of cases increases to 102.2 for men and 158.6 for women and, finally, in the age group over 50 years old we observe a noticeable decline in this index--down to 93.9 for men and down to 55.0 for women. The same trend can also be seen in relation to days, which does not contradict the data published for other industrial sectors.

Women exhibit the highest morbidity in relation to occupations--filtering machine operators (170.0 cases per 100 workers), mixer and reactor operators (156.0), bead machine operators (144.4), dye specialists (140.0), and women in auxiliary occupations (125.7).

As we had noted earlier, the workers of enamel shops experience the intermittent effects of rather high concentrations of a large number of organic solvents, frequently exceeding the maximum permissible concentrations.

On processing the data of a preventive examination of the workers in depth, we revealed presence of neurasthenic syndromes coupled with autonomic dysfunction among 28.5 percent of the workers, and autonomic-sensitive polyneuritis among 5.5 percent, which can also be interpreted as various stages of intoxication by organic solvents. Moreover rhinitis in different stages (predominantly subatrophic and atrophic) was observed among 29 percent of the workers, various forms of pharyngitis were observed among 17.6 percent of the workers, and chronic tonsillitis was observed among 12.1 percent. All of these data confirm the conclusion that factors of the production environment, chiefly particular concentrations of organic solvents, have an unfavorable effect on the health of workers.

In this connection we evaluated the production environment more attentively and came up with a number of sanitary-hygienic proposals on placing some controls on discharge of the byproducts of the production process.

Naturally we cannot ignore the effects of some social-hygienic factors when performing an integrated analysis of morbidity. Thus we studied morbidity among persons living in apartments with living space totaling less than 3 m² per family member. Morbidity was significantly higher than among persons with better living conditions. This pertained chiefly to such nosological forms as diseases of digestive organs, influenza, acute respiratory diseases, angina, and inflammatory diseases of the eyes. We also established higher morbidity among families with many children and persons experiencing an abnormal living situation in the family. This group exhibited higher morbidity in relation to diseases of the nervous system and sense organs, and hypertension. We revealed a sufficiently clear dependence of morbidity on harmful habits (smoking, excessive consumption of alcohol), the distance of the residence from the place of work, and some other factors.

As a result of this research we established a dependence of morbidity on some social-hygienic living conditions; however, the influence of this factor was relatively small. At the same time we should remember that certain factors pertaining to personal life may be an integral function of others, and that they are not always taken into account by researchers.

Thus the integrated analysis of morbidity we conducted, which we supplemented by data of the most diverse nature--from sanitary-hygienic to medical-social--permits the conclusion, with sufficient probability, that environmental and personal factors have an integrated influence on the level and specific features of the morbidity of workers producing enamel from condensation resins.

COPYRIGHT: ZDRAVOOKHRANENIYE RSFSR, 1977

11004

CSO: 1870

SCIENTISTS AND SCIENTIFIC ORGANIZATIONS

14TH SCIENTIFIC SESSION ON THE CHEMISTRY AND TECHNOLOGY OF ORGANIC SULFUR COMPOUNDS AND SULFUR CRUDE OIL

Riga IZVESTIYA AKADEMII NAUK LATVIYSKOY SSR in Russian No 2 (355) 1977
pp 143-148

[Article by A. Skorova]

[Text] The experience of the expansion of oil refining, petrochemistry and chemistry showed that a vital role in further increasing production efficiency and improving product quality is played by close investigation of natural and synthetic sulfur compounds, their removal when deleterious, preparing new sulfur derivatives with desired properties and studying the effects of organic sulfur compounds on people, animals and plants.

The 14th Scientific Session on the Chemistry and Technology of Organic Sulfur Compounds and and Sulfur Crude Oil, held last year in Batumi, summed up the results of studies in the Soviet Union in these directions and gave recommendations on the future of research.

The Session was organized by the Scientific Council of the GKNT [State Committee for Science and Technology] on the Problem "Chemistry and Technology of Organic Sulfur Compounds," Institute of Organic Synthesis of the Latvian SSR Academy of Sciences, Institute of Inorganic Chemistry and Electrochemistry of the Georgian SSR Academy of Sciences and the Batumi Oil Refinery.

About 250 took part in the session.

A total of 139 papers, including 10 plenary reports, were delivered, visually illustrated and discussed at the session. Proceedings were arranged in six sections.

Since the 13th Session, new vital results were recorded from studies of the distribution of organosulfur and other nonhydrocarbon compounds in crudes and in the development of industrial processes of refining petroleum products processes that are new and more effective in terms of their indicators (Institute of Chemistry, Bashkir Division of the USSR Academy of Sciences, Ufa; VNII NP [Scientific Research Institute of the Petroleum Industry], Moscow;

BashNII NP [Bashkir Scientific Research Institute of the Petroleum Industry], Ufa; Institute of Organic and Physical Chemistry imeni A. Ye. Arbuzov of the Kazan' Division of the USSR Academy of Sciences; and other organizations].

High-molecular-weight compounds of petroleum (HMC), especially asphaltenes, are the fraction of petroleum that is least studied and most complex in composition; owing to the sparseness of information on the structure and properties of this fraction, it has not yet found suitable uses.

The plenary report "Study of High-Molecular-Weight Compounds of Petroleum" was delivered by A. N. Plyusnin, representing Yu. G. Kryazhev (Tomsk). The report and some other communications gave the results of carrying out the integrated program of studying HMC, in the Institute of the Chemistry of Petroleum, Siberian Division of the USSR Academy of Sciences.

This program includes the improvement of methods of separation and final-stage fractionation of HMC, application of degradative effects on macromolecules of asphaltenes (in particular, ozonolysis), use of a complex of physicochemical methods of studying the structure of asphaltene fractions, synthesis of model structures containing polyconjugated systems, heteroatomic and hydrocarbon groups, studying the specific properties of HMC in comparison with the properties of synthetic models and determining ways of suitable applications and the role of the tar-asphaltene fraction of petroleum as a natural system.

From the program carried out, valuable information was secured on the structure and composition of native asphaltenes of Western Siberian petroleum; an effective method of isolating and separating HMC was proposed, based on complex formation with titanium tetrachloride. The aromatic system of polyconjugation was shown to be a characteristic element of the structure of asphaltenes responsible for their distinguishing properties.

The distinctive physical and chemical properties of the polyconjugation of the systems allow us to determine the best ways of applying HMC. Regularities and correlations brought to light must turn into the foundation for setting up fundamentally new industrial processes. HMC were shown to be suitable as extractants of nonferrous and rare metals and inhibitors of processes of free-radical degradation (in particular, stabilizers of polymeric materials).

The functions of the scientific control of the mutual influence and development of members in a three-member system--motors and mechanisms--fuels and lubricants--equipment operation must be carried out by chemmotology, a new fast-rising field of science and technology. The theoretical essentials of chemmotology are formulated with reference to the specifics of processes in motors and mechanisms, based on known theories of the combustion and oxidation of fuels, the hydrodynamic theory of lubrication, heat transfer theory, electrochemical theory of corrosion, modeling theory and so on.

Finding solutions to the problems of the chemmology of fuels and lubricants, including fuels and oils derived from sulfur crudes, bears vital scientific-theoretical and practical importance.

The plenary report "Role of Organosulfur Compounds in the Chemmology of Fuels and Oils" was delivered at the Session by Professor A. A. Bratkov (Moscow), speaking for A. A. Bratkov, Ya. B. Chertkov and S. E. Kreyn.

Sulfur compounds in fuels, as a rule, degrade operating qualities, while in oils--in optimal amounts--performance improves. It is vital not only to find out what the acceptable amounts of sulfur compounds are, but also their optimal group chemical composition.

Since sulfur compounds in oils and in fuels are the source of environmental pollution, an optimal solution must be arrived at, combining the energy, operational and industrial aspects of the problem with the ecological. In particular, along with hydrofining, there is promise seen in selective extraction of sulfur compounds from distillate fuels and--especially--residual fuels; this technique results not only in refined fuel, but also a new petrochemical feedstock.

Work is moving along well in devising industrial methods of preparing petroleum sulfides and sulfoxides and in finding new areas of their application (Institute of Chemistry of BashFAN SSSR [Bashkir Division, USSR Academy of Sciences], Ufa; NIINEftekhim [Scientific Research Institute of Petrochemical Plants], Ufa; Institute of Inorganic Chemistry, Siberian Division, USSR Academy of Sciences, Novosibirsk and other organizations).

Producing mercaptans from sulfides of petroleum is promising. Kh. I. Areshidze et al. (Institute of Physical and Organic Chemistry, Georgian SSR Academy of Sciences) pioneered in using modified forms of zeolites as catalysts in the preparation of propylmercaptane from di-n-propylsulfide.

Preparations for, and the execution of the industrial synthesis of organic compounds of sulfur that are of national-economic importance were an object of close attention by session participants.

Presented at the session were the results of developing a technology of producing primary dodecylmercaptan (NIIMSK [Scientific Research Institute of Monomers for Synthetic Rubber], Yaroslavl') and 2-methylthiophene (NIINEftekhim, Ufa), facilities making low-molecular-weight mercaptans from gas condensate (VNIIGAZ [All-Union Scientific Research Institute of Natural Gas], Moscow Oblast), thiophene and benzothiophene, both of reagent purity, from coal tar feedstock (Makeyevka Coal-Tar Plant) and hydrogenation of sulfolene-3 (Salavat Petrochemical Combine; VNII NP, Moscow); a industrial flow-sheet was proposed for isolating refined naphthalene and benzothiophene by liquid extraction (IOKh [Institute of Organic Chemistry] imeni N. D. Zelinskiy, Moscow) and others.

The Institute of Catalysis, Siberian Division of the USSR Academy of Sciences (Novosibirsk), jointly with the NIINeftekhim (Ufa) proposed a catalytic process of liquid-phase oxidation of petroleum sulfides into sulfoxides using air.

Much attention at the session was paid to preparing sulfur-containing monomers and polymers. These research efforts are advancing well in the Institute of Chemistry of the BashFAN SSSR (Ufa), the Institute of Petrochemical Synthesis, USSR Academy of Sciences (Moscow), the All-Union Scientific Research and Planning Institute of Monomers (Tula), the Institute of Chemical Sciences, Kazakh SSR Academy of Sciences (Alma-Ata) and other organizations.

Methods of synthesizing sulfur-containing monomers and intermediates for heat-resistant materials were presented in the report of Professor G. S. Mironov in coauthorship with Yu. A. Moskvichev and M. I. Farberov (Yaroslavl' Polytechnic Institute). They have studied effective methods of synthesizing aromatic sulfochlorides, thiophenols, sulfones and diimides of disulfodicarboxylic acids, which are monomers and intermediates for the preparation of polysulfones and polyester-sulfones--thermoplastic colorless polymers exhibiting enhanced thermal stability, self-extinguishability and high hydrolytic stability in the presence of acids and bases. Much attention was given to problems of investigating reactivity, kinetic regularities of reactions and to examining reaction mechanisms.

A leading center in the chemistry of organic compounds of sulfur in our country is the Irkutsk Institute of Organic Chemistry, Siberian Division, USSR Academy of Sciences. That is why the organizing committee felt it was best to schedule at the session a review paper on investigations conducted by the institute, delivered by Professor B. A. Trofimov in the name of M. G. Voronkov, B. A. Trofimov and V. A. Usov.

One primary direction in the institute's work is searching for and developing new preparative reactions for industrial and final-stage organic synthesis on the basis of accessible and cheap feedstock.

Thus, on the basis of acetylene and hydrogen sulfide, sulfides and polysulfides of metals, elementary sulfur and its nearest derivatives, new polymers were prepared and have become industrially accessible--vinyl sulfides, including functionally substituted vinyl sulfides. Prominent in this class is divinyl sulfide. The most immediate prospect of its application is in replacement of divinylbenzene in synthesizing ion exchange resins, sorbents and rubber.

In reacting with sulfones, divinyl sulfide forms liquid polysulfide oligomers--a new type of thiokol.

Divinyl sulfoxide made from divinyl sulfide combines with the most diverse nucleophiles in very mild conditions and nearly quantitatively, forming the corresponding vinyl sulfoxyl derivatives.

Poly-addition to divinyl sulfoxide exhibited by a variety of bifunctional addends opens up the way to making new polymers, including water-soluble and biologically active polymers.

In the reaction of hydrated sodium sulfide with vinyl acetylene, di(butadienyl) sulfide is produced at good yield.

In reacting with diacetylene, sodium sulfide yields thiophene at a virtually quantitative yield and the purity of the crude thiophene is 99.9 percent.

From available diacetylene glycol, thiophene glycol was synthesized; when acted on by potassium bisulfide, thiophene glycol readily dehydrates into 2,5-diisopropenyl thiophene; the latter was used as the starting-point in a method of preparing new sulfopolystyrene cation exchange resins.

Under study are reactions of the nucleophilic addition of thiol and thionic acids to triple bonds; in a number of cases, it is possible to attain quantitative yields. Thus, the shortest path to new monomers--precursors of polyvinylthiol--has been blazed.

Sulfur compounds can also be prepared at high temperatures by the reaction of halogen derivatives of benzene, naphthalene and thiophene with hydrogen sulfide or thiophenol.

In the institute, promising reagents have been synthesized, part of the class of alkylthioacrolein; detailed study is underway on preparative methods, structures and transformations of vinyl analogs of thioamides of the indene and cyclohexene series; under development are methods of preparing and studying the reactivity and structure and structural theory of sulfur-containing organic compounds of group VI-B elements.

Considerable institute attention is directed toward theoretical and physico-chemical investigations of organosulfur compounds. Under study is the ability of the sulfur atom to enter into some kinds of conjugations and the extent to which these effects influence the properties and reactivity of organosulfur compounds.

Currently, radiation chemistry has permeated many fields of the national economy.

Outstanding in promise is the development of a process of radiation desulfurization of sulfur crude oils and the utilization as a result of high-purity organosulfur compounds. Radiation-chemical synthesis of compounds with differing functional groups, study of the radiation behavior of sulfur compounds, biologically active compounds included, comparison of this behavior with the behavior of other classes of organic compounds, establishment of the scientific essentials of radioprotective effects and determining the overall regularities--these are the salient lines of research in the radiation chemistry of organic compounds of sulfur.

Broadly presented at the session was the chemistry of cyclic sulfides, sulf-oxides and sulfones (Institute of Chemistry, BashFAN SSSR, Ufa; Institute of Chemistry, Tadzhik SSR Academy of Sciences, Dushanbe; Institute of Organic and Physical Chemistry imeni A. Ye. Arbuzov, Kazan' Division, USSR Academy of Sciences, Kazan'; INKhS [Institute of Petrochemical Synthesis] imeni A. V. Topchiyev, Moscow and other organizations).

Yu. Ye. Nikitin et al. (Institute of Chemistry, BashFAN SSSR, Ufa) summed up the results of synthesizing and preparing individual and petroleum sulf-oxides; a study was made of the features and regularities of extracting--with sulfoxides--of mineral and organic acids and salts of metals; an explanation was given for the extractivity of sulfoxides as a function of the molecular structure of the extractants; methods of preparing individual and petroleum sulfoxides with prespecified properties were described; and projected areas for applying petroleum sulfoxides were outlined.

With the example of sulfur-containing cyclohexanes, N. S. Zefirov (Moscow State University imeni M. V. Lomonosov) looked at the principal conformational features of sulfur-containing compounds within the framework of effects "across bonds" and across "space." The relative importance of each class of effects is weighed by the VMO method.

Thiophene chemistry has seen continued advances in the work done by staff members at the Institute of Organic Chemistry imeni N. D. Zelinskiy, the Kuy-byshev Polytechnic Institute and so on. Of not only theoretical, but also preparative interest are the correlations examined in the plenary report by Doctor of Chemical Sciences L. I. Belen'kiy (Institute of Organic Chemistry imeni N. D. Zelinskiy, Moscow): these correlations deal with the chemical behavior of thiophene and furan series compounds caused by the high activity of these heterocyclic systems and the enhanced stability of the sigma-com-plexes induced by the attack of an electrophilic agent, as well as the possi-bility of modifying the "normal" directivity of electrophilic substitution as a consequence of reversible modification of functional groups (in parti-cular, as the result of complex formation and protonation).

E. V. Todres and S. P. Avagyan (INEOS [Institute of Hetero-organic Compounds] of the USSR Academy of Sciences, Moscow) summed up the role of electronic processes in reactions of organic derivatives of bivalent sulfur.

Attention was also directed to the biological aspects of electron transfer.

I. V. Bodrikov et al (Gor'kiy Polytechnic Institute) advanced an effective method of promoting new directions in the AdE-reactions of unsaturated com-pounds, leading to a variety of functionally-substituted sulfur-containing compounds.

Catalytic synthesis and transformations of organic sulfur compounds were re-presented by the studies of the Institute of Organic Chemistry imeni N. D.

Zelinskiy, USSR Academy of Sciences, Moscow State University imeni M. V. Lomonosov, Institute of Catalysis, Siberian Division, USSR Academy of Sciences and others.

Significant attention focused on certain N,S-containing organic compounds.

Several communications dealt with the synthesis and properties of organoelemental derivatives of sulfur (Institute of Organic Synthesis, Latvian SSR Academy of Sciences, Riga; IRIOKh; and Leningrad Technological Institute imeni Lensovet). In the Institute of Organic Synthesis, Latvian SSR Academy of Sciences, new sulfur heterocycles containing boron and silicon are being synthesized; thienyl derivatives of aminoalkylsilanes exhibiting effects on the central nervous system were prepared.

In many of the country's scientific centers, work is underway on the synthesis and study of the biological action of organic sulfur compounds; new types of pharmacologically effective compounds were found; compounds with pesticidal properties were prepared and investigated.

In the plenary report of the council chairman, Corresponding Member of the Latvian SSR Academy of Sciences, G. I. Chipens, "Chemistry and Biology of Sulfur-containing Peptides and Proteins," a review was made of investigations on the structure, functions and action mechanisms of sulfur-containing peptides and proteins, primarily with the examples of glutathion, oxytocin, vasopressin and insulin, vital in coordinating physiological processes in the organism and metabolic reactions. Examined and discussed was the role of -SH- and -S groups in determining the functional activity of hormones. Of singular interest was the work done under his supervision in the Institute of Organic Synthesis, Latvian SSR Academy of Sciences, dealing with the structural-functional organization of sulfur-containing peptides--hormones, toxins and so on. A model was proposed for this organization; a new type of active center was uncovered.

The organization of peptide synthesis in industrial conditions--for the first time in the USSR--was a practical outcome of theoretical studies. Hormonal preparations pentagastrin and oxytocin were introduced into commercial production and certified for medical and veterinary uses.

A pharmacological study of amino derivatives of 2-chloro-benzo[b]thiophensulfone (Institute of Organic Chemistry, Latvian SSR Academy of Sciences) showed that a new class of psychotropically and gangliolytically active compounds has been discovered.

The plenary report of S. N. Litvinenko and G. A. Preys (Kiev Technological Institute of the Food Industry) and several sectional and visual-display papers were concerned with polyfunctional additives--exhibiting antimicrobial activity--to petroleum products.

Of no less importance is preventing undesirable microbiological processes in petroleum products occurring when they are stored and used in the tropics and degrading physicochemical and operating qualities of fuels, oils and lubricants, corrosional changes in metal structures contacting affected petroleum products and the malfunctioning of utilities and filtration assemblies plugged with biomass.

Wide-ranging use of sulfur compounds in the national economy has confronted the biomedical sciences with a series of theoretical and practical problems, including hygienic concerns.

When organic compounds of sulfur are produced, observance of labor hygiene has two fundamental aspects: a) the effects on workers of organic and inorganic compounds of sulfur differing in toxicity, as part of polycomponent mixtures; and b) strongly disagreeable stench of certain sulfur compounds.

Professor L. K. Kwartovkin, in a provocative plenary report, "Questions of Labor Hygiene and the Odor Problem in Organosulfur Synthetic Production Facilities," which he delivered in co-authorship with Ye. A. Meyerson and S. P. Popov, showed that when solving problems of labor hygiene, developing the technology and in designing production complexes of sulfur compounds, account must be given to the importance of the odor problem. The department he has headed at the Volgograd Medical Institute has been studying for 10 years a number of indicators of worker health at several production facilities of chemical complexes that are sources of odoriferous discharges of sulfur compounds. Morbidity levels with temporary loss of work function are being analyzed, along with results of detailed medical examinations and clinical-biochemical and clinical-immunological indicators.

It was found that odor, independently of toxicity of a given compound, can act as an autonomous production factor, as a factor bearing on job acceptance, personnel work stability and the social adaptation of workers.

Presented at the session were the results of hygienic investigations of working conditions at several facilities making organic sulfur compounds and studies of the combined effect of sulfur compounds entering the organism in different pathways and the metabolism of sulfur compounds.

In conclusion, an expanded decision was adopted, spelling out more clearly the tasks facing the organizations at work in the field of the chemistry and technology of organic compounds and containing some recommendations for the national economy.

The Institute of Organic Synthesis, Latvian SSR Academy of Sciences, was represented at the session by the following papers, in addition to a plenary report: R. O. Vitolin', V. E. Udre and A. A. Kimenis, "Effect of Derivatives of 2-Chloro-3-organylamino-benzo[b]thiophensulfone on the Cardiovascular System and Smooth Musculature"; A. A. Kimenis, R. O. Vitolin', V. V. Solov'yeva, G. Ya. Dubur, N. V. Kondratenko and L. M. Yagupol'skiy, "Results of Pharmacological Study of Sulfur-Containing 1,4-Dihydropyridines"; S. K. Germane and

V. E. Udre, "Study of Antispasmodics and Psychotropics Among Derivatives of 2-Chloro-3-organylamino-benzo[b]thiophene"; Ye. M. Belevich and G. A. Veynberg, "Configurational Stability of the Protein Chain of Derivatives of 6-Amidinopenicilloic Acid"; L. T. Kaulinya, R. A. Zhuk and S. A. Giller (deceased), "1-Substituted 4-Thiouracils"; G. I. Zelchan, I. I. Solomennikova, E. E. Liyepinysh, I. S. Yankovska, I. B. Mazheyka and E. Ya. Lukevits, "New Sulfur Heterocycles Containing Boron and Silicon"; E. Ya. Lukevits, M. A. Dzintara, N. P. Yerchak and V. I. Savushkina, "Interaction of Thienylhydro-silanes with Amino Alcohols and Unsaturated Amines"; and N. O. Saldabol and O. Ye. Lando, "Dimethylsulfoxide: a Reagent in the Synthesis of alpha-Halogen-substituted Imidazo(1,2-a)pyridine, Its Aza- and Thia-analogs."

COPYRIGHT: Izdatel'stvo "Zinatne," "Izvestiya Akademii nauk Latvyskoy SSR", 1977

10123

CSO: 1870

END