

JPRS 72194

7 November 1978

TRANSLATIONS ON EASTERN EUROPE
SCIENTIFIC AFFAIRS
No. 606

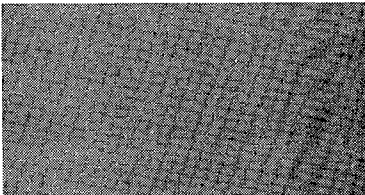

EAST

EUROPE

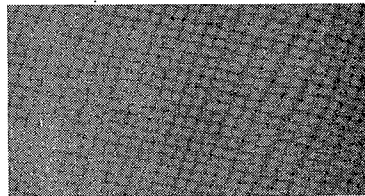

Reproduced From
Best Available Copy

U. S. JOINT PUBLICATIONS RESEARCH SERVICE

DISTRIBUTION STATEMENT A
Approved for Public Release
Distribution Unlimited

20000315 085

NOTE

JPRS publications contain information primarily from foreign newspapers, periodicals and books, but also from news agency transmissions and broadcasts. Materials from foreign-language sources are translated; those from English-language sources are transcribed or reprinted, with the original phrasing and other characteristics retained.

Headlines, editorial reports, and material enclosed in brackets [] are supplied by JPRS. Processing indicators such as [Text] or [Excerpt] in the first line of each item, or following the last line of a brief, indicate how the original information was processed. Where no processing indicator is given, the information was summarized or extracted.

Unfamiliar names rendered phonetically or transliterated are enclosed in parentheses. Words or names preceded by a question mark and enclosed in parentheses were not clear in the original but have been supplied as appropriate in context. Other unattributed parenthetical notes within the body of an item originate with the source. Times within items are as given by source.

The contents of this publication in no way represent the policies, views or attitudes of the U.S. Government.

PROCUREMENT OF PUBLICATIONS

JPRS publications may be ordered from the National Technical Information Service, Springfield, Virginia 22151. In ordering, it is recommended that the JPRS number, title, date and author, if applicable, of publication be cited.

Current JPRS publications are announced in Government Reports Announcements issued semi-monthly by the National Technical Information Service, and are listed in the Monthly Catalog of U.S. Government Publications issued by the Superintendent of Documents, U.S. Government Printing Office, Washington, D.C. 20402.

Indexes to this report (by keyword, author, personal names, title and series) are available through Bell & Howell, Old Mansfield Road, Wooster, Ohio, 44691.

Correspondence pertaining to matters other than procurement may be addressed to Joint Publications Research Service, 1000 North Glebe Road, Arlington, Virginia 22201.

BIBLIOGRAPHIC DATA SHEET		1. Report No. JPRS 72194	2.	3. Recipient's Accession No.		
4. Title and Subtitle TRANSLATIONS ON EASTERN EUROPE - SCIENTIFIC AFFAIRS, No. 606				5. Report Date 7 November 1978		
7. Author(s)				6.		
9. Performing Organization Name and Address Joint Publications Research Service 1000 North Glebe Road Arlington, Virginia 22201				8. Performing Organization Repr. No.		
10. Project/Task/Work Unit No.				11. Contract/Grant No.		
12. Sponsoring Organization Name and Address As above				13. Type of Report & Period Covered		
				14.		
15. Supplementary Notes						
16. Abstracts The serial report contains articles concerning the development of and progress in the various theoretical and applied scientific disciplines and technical fields; and the administration, structure, personnel, and research plans of leading East European scientific organizations and institutions, particularly the academies of sciences.						
17. Key Words and Document Analysis. 17a. Descriptors						
<table style="width: 100%; border: none;"> <tr> <td style="width: 50%; border: none;"> <input type="checkbox"/> International Affairs <input type="checkbox"/> Albania <input type="checkbox"/> Bulgaria <input type="checkbox"/> Czechoslovakia <input type="checkbox"/> East Germany <input checked="" type="checkbox"/> Hungary <input checked="" type="checkbox"/> Poland <input type="checkbox"/> Romania <input checked="" type="checkbox"/> Yugoslavia </td> <td style="width: 50%; border: none;"> Scientific Societies Research Management Organizations Research </td> </tr> </table>					<input type="checkbox"/> International Affairs <input type="checkbox"/> Albania <input type="checkbox"/> Bulgaria <input type="checkbox"/> Czechoslovakia <input type="checkbox"/> East Germany <input checked="" type="checkbox"/> Hungary <input checked="" type="checkbox"/> Poland <input type="checkbox"/> Romania <input checked="" type="checkbox"/> Yugoslavia	Scientific Societies Research Management Organizations Research
<input type="checkbox"/> International Affairs <input type="checkbox"/> Albania <input type="checkbox"/> Bulgaria <input type="checkbox"/> Czechoslovakia <input type="checkbox"/> East Germany <input checked="" type="checkbox"/> Hungary <input checked="" type="checkbox"/> Poland <input type="checkbox"/> Romania <input checked="" type="checkbox"/> Yugoslavia	Scientific Societies Research Management Organizations Research					
17b. Identifiers/Open-Ended Terms						
17c. COSATI Field/Group 5B						
18. Availability Statement Unlimited Availability Sold by NTIS Springfield, Virginia 22151			19. Security Class (This Report) UNCLASSIFIED	21. No. of Pages 31		
			20. Security Class (This Page) UNCLASSIFIED	22. Price		

TRANSLATIONS ON EASTERN EUROPE
SCIENTIFIC AFFAIRS

No. 606

CONTENTS

PAGE

HUNGARY

Circuit Simulator Program With Display for Designing
Integrated Circuits
(Vladimir Szekely, Dalman Tarnay; HIRADASTECHNIKA, Sep 78) 1

Briefs
Computers Statistics 12

POLAND

Space Research Program Outlined
(Warsaw Domestic Television, 25 Oct 78) 13

YUGOSLAVIA

Technical Data on Krsko Nuclear Power Station
(Milorad Kapor; TEHNIKA, No 6, 1978) 14

HUNGARY

CIRCUIT SIMULATOR PROGRAM WITH DISPLAY FOR DESIGNING INTEGRATED CIRCUITS

Budapest HIRADASTECHNIKA in Hungarian No 9, Sep 78 pp 257-263

[Article by Dr Vladimir Szekely and Dr Kalman Tarnay, of the Electronic Tools Faculty of the Budapest Technical University, and Peter Bernus, of the Computer Technology and Automation Research Institute of the Hungarian Academy of Sciences: "TRANZ-TRAN 3/D--A Display Operating, Interactive Circuit Simulation Program"]

[Text] It is a worldwide phenomenon that computer methods are playing an ever greater role in the design of integrated circuits. Computer planning systems help the designer in every phase of the work already, in designing the circuits and planning construction as well as in preparation of the masks. In 1974-1977 our faculty developed a complex computer designing system which assists the entire process of IC design. In regard to configuration the system is suitable for designing both monolithic and insulator based integrated circuits. The concrete realization serves the design of insulator based circuits--since this was the direction of the need which arose. We did the work on a commission from the Central Physics Research Institute and the REMIX Radio Technology Enterprise. The program system, which helps the REMIX designers in the designing of thick and thin layer integrated circuits, consists of the following parts:

- TRANZ-TRAN 3/D nonlinear circuit analysis program,
- AKSZ-1 active filter synthesis program,
- TRAFIC transversal filter designing program,
- VASTAGIC thick layer IC construction designing program,
- VEKONYIC thin layer IC construction designing program,
- MASZK mask production program,
- ADATBANK, a data bank which stores all the electric, geometric, etc. information pertaining to the circuit elements and materials to be used, and

--MS1 and MS2 statistical program packages.

All of the designing programs listed are display-interactive in operation. The programs are linked to one another directly, each transferring to the other the data for the circuit being designed. Thus the design of each circuit constitutes a uniform process. The designer sits in front of the display and first performs a circuit simulation. By means of modifications and repeated analysis he arrives at a final circuit (in the case of some special circuits--for example, active filters--the circuit is produced by a special program segment through direct synthesis). He then calls in the construction design program. He selects materials and parts from the data bank and prepares a layout plan on the screen. He works out the connecting wiring. He can then see on the display screen the entire mask which he has designed and if everything is in order he directs the program to transmit the data to the plotter. This is a single, uninterrupted machine designing process from the IC specifications to the finished masks and in this respect our design system is unique in our homeland.

The purpose of our present article is to describe one part-program of the system, the TRANZ-TRAN 3/D circuit simulation program. This program works not only as part of the system but also independently--with an appropriate TPA [stored program data processing] machine configuration. Its unique nature, as compared to the usual circuit simulation programs, is that it is a display operating, interactive program. The designer has only to draw the circuit to be analyzed on the picture screen; the machine performs the desired analysis and displays the results graphically on the display screen, in the form of drawings.

This organization of the man-machine link, a new one for us, is of very great significance from the viewpoint of convenient use of the program and easy interpretation of the results. "One has only to sit down before the screen." Prior knowledge of computer technology is entirely unnecessary and the attractive nature of the visual man-machine link will surely win new believers for our circuit design program.

General Characteristics of the TRANZ-TRAN 3 Circuit Analysis Program

Our faculty has been dealing for about 10 years with the development of universal circuit simulation programs. As a result of this work there have been several versions over the years of the TRANZ-TRAN 2 circuit analysis program.^{1,2,3} This program, recognized and used by many, is now compatible with five domestic medium and large computers. In 1974-1975 we developed a version of the program which operates on a TPA small computer; this is the TRANZ-TRAN 3. This program, prepared and published in 1975, still used only printer output and was not interactive. In 1977 we developed from it an interactive version, designated the 3/D, controlled from the display which we publish for the first time here.

TRANZ-TRAN 3, published in 1975,^{4,5} was unique in its own right in that it realized for the first time on a small computer the task of universal

nonlinear circuit simulation, functions which had been realized previously only on medium or large machines. When designing it it was our purpose to save in the small computer version most of the services of the TRANZ-TRAN 2 analysis program used on large machines.

We call attention to our works published earlier in connection with the large computer versions of our analysis program, with the question of adaptation to a small machine and with algorithms and models of the programs.^{1,6,7,8} We will list here only the specifications data for the small machine program which was developed.

Types of analysis: DC analysis, transfer characteristics computation, sensitivity test, AC analysis, and transient analysis.

Circuit elements, models: voltage and current generator, resistance, capacitance, semi-conductor diode, bipolar transistor, field controlled transistor and circuit module (e.g., for description of operation amplifiers).

Permitted net dimensions: 30 junctions and 60 branches.

Algorithms: The nonlinear equation system solution is by Newton-Raphson iteration. Integration within the time domain is by the reverse Euler method.

The 3/D version of the program described in this article differs from the original TRANZ-TRAN 3 only in the method of maintaining contact with the designer (display, interactive operation) and is identical in other respects. Thus the listed specifications data also apply to the 3/D version.

The new services in the 3/D version are as follows:

--The circuit is introduced in an interactive mode by "drawing" the circuit on the picture screen;

--The program delivers the results of the analyses graphically with the aid of function diagrams appearing on the screen; and

--After every result is presented it is possible to erase or modify certain parts of the circuit and do another analysis.

General Problems of the Interactive Program

The TRANZ-TRAN 3/D program can be operated on the following machine configuration:

--TPA central unit with 16 K memory (12 bit words);

--NE-601/i type raster display;

--Disk, with a capacity of at least 64 K; and

--Fast punch tape reader.

It is advantageous if, in addition to these, the system includes a fast perforator and a line printer.

We should describe separately the display equipment--since this is the only unconventional unit of those listed. It is characteristic of the NE-601/i model that, in the manner usual for television, its electron ray traces the picture screen line by line and can write points of light by line only in points placed in equal density. Thus points of determined rows and columns can appear on the screen. This is how it gets its name, point raster display. In our case the raster consists of 180 by 240 points. This makes possible the depiction of pictures with only moderate detail. Using several programming tricks we arranged it so that this resolution should be sufficient for the given task. We will refer to these later. The display does not have its own memory; the picture content to be displayed is stored in the central memory. This means, unfortunately, that during presentation the display takes up 22 percent of the memory.

The display unit has two input units (Diagram 1). One of these is an alphanumeric keyboard. The other is a device serving to introduce graphic information, the so-called positioning ball or "track ball." This is a control device which can be turned in an x or y direction, as indicated in the diagram. A point of light (the cursor) independent of the point raster moves on the screen in synchrony with its movements. The coordinates of the cursor can be read from the program. Thus if we designate one point on the screen with the cursor than we have simultaneously communicated the coordinates of the point with the program.

The small central memory represented the most serious organizational problem in connection with the interactive analysis program. About one quarter of the 16 K memory is taken up by the necessary functions and input-output and floating decimal routines. The display--if the program is using it--takes up another 3.6 K. The program and all data fields must fit in the remaining area. This could be done only with extensive utilization of the disk background and application of overlay techniques. The length of the complete program file placed on disk is about 30 K words. The program segments stored in this file--on follow one after another in an overlay field taking 6 K of the central memory. In addition the disk also serves for intermittent storage of data files and graphic files.

The structure of the program can be followed easily on the basis of the block diagram shown in Diagram 2. The first program segment is that of the graphic circuit input. We then reach the main branch point of the program, which appears with the following menu:

1. DC ANALYSIS
2. TRANSFER CHARACTERISTICS
3. SENSITIVITY
4. AC ANALYSIS
5. TRANSIENT ANALYSIS
6. MODIFICATION
7. NEW CIRCUIT
8. END OF RUN

If we choose analysis then after it is done the applicable documenting routines follow. Leaving documentation we are again at the main branch point. We can now ask for a new analysis but it is also possible to modify the circuit (continuing graphic circuit input) or to analyze a new circuit (control returning to the beginning of the program).

Graphic Circuit Input

"The designer need only draw the circuit on the screen" is a statement which sounds good but it must be explained more precisely what operations this covers. Several solutions could be imagined. The most elegant method is where the designer really draws, drawing the circuit to be tested on the screen with a light pencil. Its practicality, however, is debatable. In the first place pattern recognition burdens the program with a complex problem (the program must establish from symbols drawn in free style which represent resistance, which represent transistors, etc). In the second place it places serious demands on the designer; he must prepare a diagram which is machine readable and which thus must be drawn very carefully.

In the other possible solution for "drawing" on the screen it is necessary only to designate on the screen the desired position of the part. What part goes in this position is either designated with the cursor from a selection of parts displayed on the edge of the screen in diagram form (a graphic menu) or the designer indicates this by pressing one or another of the keys on the display keyboard. As a result of this a standard graphic representation of the part appears at the designated spot. Thus there is no need for careful drawing or pattern recognition.

We decided on the second solution when developing our program--for the reasons listed and one other. The first solution was ruled out in practice by the fact that the graphic input device of the display available was not--as we have seen--a light pencil but rather was a positioning ball. To produce with the latter a drawing of acceptable quality which would be machine readable would require very great practice and would be a lengthy operation.

In our program the parts and the connecting lines can be drawn between neighboring points of a point network (Diagram 3). In answer to the query ELEM ? we first designate an area between two points of the point network using the positioning ball and then press the code for the desired part on

the keyboard (e.g., R for resistance, C for capacitance, TN for an npn transistor, etc).

The program then requests the value of the element depicted (type character, possible other data). We give the answer on the keyboard. The insertion of another part can then follow.

The circuit drawing method described makes possible, according to experience, very quick input and it can be mastered in a few minutes. In our opinion it is the optimal method for graphic circuit input.

Naturally the program is recording the input of each part not only on the screen. It is building internal tables of the circuit being constructed. The most important elements of this are:

- a parts list (parts in order of input, coded with a numeric code),
- a list of values or type characters,
- position data for the parts (where they are placed on the screen),
- an "occupation table" of the screen (what branches of the point network are empty and which are already occupied by parts).

Every operation is recorded simultaneously on the screen and on the above tables. If, for example, we erase a part then its picture disappears together with the list elements which correspond to it.

The graphic input also makes possible the crossing of lines. With appropriate instructions crossing horizontal and vertical lines can be made electrically independent. The horizontal line breaks on the screen at the crossing point (as can be seen in Diagram 3) as if it were hidden under the vertical one.

The low resolution of the display made it impossible to write the values on the screen beside the parts. To make up for this we provided the possibility for re-querying. By pressing the ? key we can ask for the data for the part on which the cursor is standing. Then the value or type character appears at the bottom of the screen.

After the completion of circuit input the program works for a few seconds independently, without the cooperation of the designer. The program segment going into operation at this time measures the topology of the network and produces an "internal description" of the circuit. Measuring the topology means a systematic mapping of the question "which part is connected to which." The essence of the solution is as follows. A connecting line drawn between two network points on the screen makes these two network points equivalent. The program takes this into consideration by renumbering the network points; the serial number of one of the two network points connected by a line is given the superscript of the serial number of the

other. This operation is performed in an appropriate sequence for every linkage, finally producing a network point numeration wherein the electrically equivalent network points carry the same serial number. This numeration corresponds to the other parts of the program.

In machine design it is a typical requirement that we be able to return repeatedly to the simulation of some circuit (various analyses, testing variants of the circuit). It is not necessary in such a case to perform graphic circuit input. A circuit drawn on the screen once can be stored on punched tape (see the block diagram in Diagram 2, the dotted line). At a later point this tape can be read into the machine, the connection diagram appears on the screen and the diagram can be subjected to further analysis (directly in the form read in or after modification).

Graphic Documentation

Just as we might measure a board model of a circuit in question with meters and oscilloscope the program provides the designer in front of the screen with results in just this form. Where possible the results are given in the form of functions, in a graphic way. This is a great step in the direction of descriptiveness and clarity as compared to the tabular presentation of results with non-interactive simulation or, in the best case, the crudely quantified line printer depiction of a function.

The method of presenting results differs from analysis to analysis. At the end of a direct current analysis a picture of the circuit tested appears on the screen with a small boxed field in the lower right corner (Diagram 4). The latter now functions as the readout of a digital voltmeter. Using the cursor as the metering head of a voltmeter one "contacts" any point of the network and the voltage of the corresponding point appears in the boxed field. Note that in Diagram 4 the cursor is on the emitter of the right hand transistor and we can read a voltage of 8.071 V for this point in the lower right corner.

An entirely different type of result presentation is needed during transient analysis. The transient wave forms should appear as on an oscilloscope screen, and thus graphing was the most practical solution. Let us look at an example. We see in Diagram 5 a free running multivibrator. Diagram 6 gives the results of a transient analysis of this. The continuous line shows the calculated wave form of the base of the left hand transistor, the dotted line shows the calculated wave form of the collector. We can see in this way the signal form of any point of the network. As in the case of DC documentation here also the junction in question is designated by the cursor and the signal form of the corresponding point appears as a result. We can also depict the wave forms of several junctions superimposed; the picture is similar to that provided by a multiple ray oscilloscope.

Because of the low resolution of the display the finer details of the transient time functions might be lost. This can be overcome by the

enlargement function of the documentation; the small details of the functions designated can be enlarged to fill the entire screen. For example, we might select to be enlarged one small part of the base wave form shown in Diagram 6 (see Diagram 7a). As a result of the enlargement instruction this detail fills the entire screen (Diagram 7b) and thus we can study the fine details of the wave form.

In another respect also the low resolution caused problems here. We had to scale the functions appearing in some way so that we could read off numeric values. In this case we could not use the customary solution, a coordinate axis with scored dividing lines; there simply would not have been any room for the functions. We finally solved this problem with the cursor too. We now see two data numbers in the small field in the lower right corner (Diagram 6); these are the momentary coordinates of the cursor. The vertical coordinates represent volts and the horizontal coordinates represent seconds, since the cursor is now moving in our voltage-time coordinate system. As we move the cursor the two coordinates data appearing change. Stopping at any point of the displayed function we can read the data for this point in the lower right corner. Experience also shows that this is a very practical way to scale the functions presented. It provides a precise and convenient read-out possibility. In our opinion it would be useful to use the solution described even if the resolution permitted the depiction of scaled coordinate axes.

Transfer characteristic documentation did not really present any new problems as compared to the transient analysis. The only difference is that here the problem was to depict voltage-voltage functions, but the presentation possibilities, the enlargement of details and the method of scaling completely coincide with the transient documentation version. We thus provide only one example here; a TTL inverter and its transfer characteristics can be seen in diagrams 8 and 9.

Documentation of the results of an AC analysis presented somewhat more complicated problems. Here also several types of depiction are customary-- Bode diagrams or graphs of a complex locus curve character. For this reason we gave the designer the possibility of a choice. He can request an amplitude diagram (the vertical axis being transmission in dB and the horizontal axis a logarithmic frequency axis) or a phase diagram (the vertical axis being the phase angle and the horizontal the logarithmic frequency) or a locus curve (the vertical axis being the imaginary part of the transmission and the horizontal the real part with frequency as a parameter).

We see in Diagram 4 a connection for an audio frequency amplifier. Performing an AC analysis of this we present the results in the form of an amplitude diagram and a locus curve (Diagrams 10 and 11). Magnification of details and value readout are performed with the cursor in the same way already described. Providing a read-out of the parameters in the case of a locus curve using frequency as a parameter is a new problem.

We solved this by having a flashing point which can move on the locus curve from the smallest frequency to the largest; the frequency value belonging to this point also appears in the lower right corner of the picture.

Conclusions

Finally we must examine what place a small computer interactive program has in the ranks of circuit simulation programs. It is a frequent objection to small computer solutions that they are not suitable for the analysis of large networks. It is our experience, however, that it is rarely necessary in practical circuit design work to provide an analog analysis of networks larger than 30 junctions (the designer cannot really review more at one time). It is practical to do the simulation separately for the parts of the network which can be distinguished; thus the small computer program is suitable for solving a significant part of the problems.

The relative slowness of a small computer version does appear to be a disadvantage. Actually the TPA [stored program data processing] program is 10-20 times slower than the larger TRANZ-TRAN versions. But this does not mean that it is not economical! Comparing machine hours the small computer is 30-60 times cheaper to operate than a medium or large computer. So in the final analysis it is more economical to run a TRANZ-TRAN program on one.

Direct access--the fact that the program can be in place in the small computer and that results can be obtained within the hour--is an advantage which cannot be sufficiently emphasized. The developmental trend appearing in recent years in terms of computer hardware offers further prospects. One can expect a spread of small microprocessor computers with a capacity similar to the TPA, with a drastic reduction in price and size. A small microprocessor computer plus display unit on the desk of a designer is already a reality and within a few years it will cost no more than a more expensive laboratory instrument. Small computer design programs (like the TRANZ-TRAN 3/D introduced here) will then demonstrate their real significance.

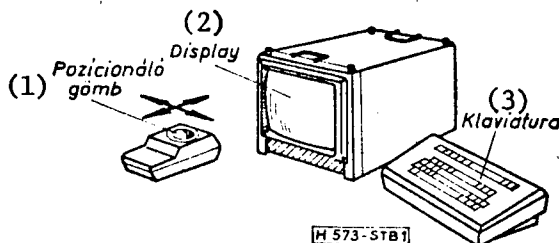

Diagram 1. The NE-601/i raster display and its operating devices.

Key: 1. Positioning ball 2. Display 3. Keyboard

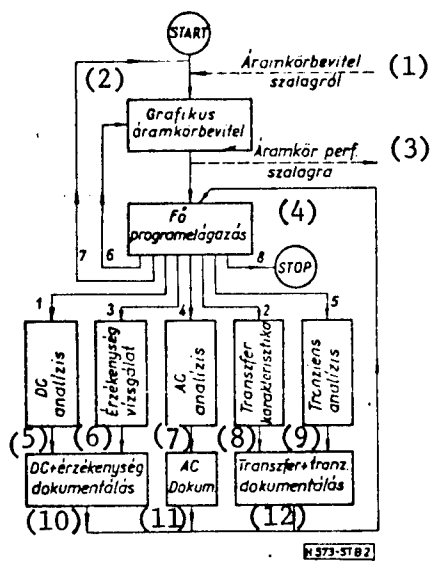

Diagram 2. Block diagram of the TRANZ-TRAN 3/D program.

Key:

1. Circuit input from tape
2. Graphic circuit input
3. Circuit perforated on tape
4. Main program branch
5. DC analysis
6. Sensitivity test
7. AC analysis
8. Transfer characteristic
9. Transient analysis
10. DC and sensitivity documentation
11. AC documentation
12. Transfer and transient documentation

Diagrams Not Reproduced (picture screens)

Diagram 3. The point network appearing on the screen and a depicted circuit.
ELEM ? is the element query.

Diagram 4. Presentation of results after direct current analysis. One can always see in the lower right corner the voltage of the junction which we have designated on the screen.
DC ANALIZIS EREDMENYEI means "results of DC analysis"

Diagram 5. Picture of a free running multivibrator on the screen.

Diagram 6. Presentation of results of transient analysis; the wave forms of the base and collector of the multivibrator are on the screen.
TRANZIENS IDOFUGGVENYEK means "transient time functions"

Diagram 7. Enlargement of details of the functions. We first indicate the detail of the base wave form to be enlarged (a) which then fills the entire screen (b).

Diagram 8. Connections picture of a TTL inverter.

Diagram 9. The transfer characteristic of the inverter appears thus after analysis.

TRANSZFER FUGGVENYEK means "Transfer functions"

Diagram 10. Bode diagram of the circuit which can be seen in Diagram 4. The cursor is at one of the break points and the data for this can be read in the lower right corner.

AC AMPLITUDO DIAGRAM means "AC amplitude diagram"

Diagram 11. The locus curve of the amplifier in Diagram 4, on a complex plane.

AC HELYGORBE means "AC locus curve"

BIBLIOGRAPHY

1. Dr K. Tarnay and Dr V. Szekely: "The TRANZ-TRAN Nonlinear Circuit Analysis Program," HIRADASTECHNIKA, No 9, 1973, pp 257-264.
2. Dr K. Tarnay and Dr V. Szekely: "The TRANZ-TRAN 2 Nonlinear Circuit Analysis System," a publication of the 1972 meeting "Programming Systems," Szeged, 1972, pp 299-303.
3. P. Bencsath and Dr V. Szekely: "The TRANZ-TRAN Circuit Analysis Program and Its Application in the Design of Hybrid Circuits," HIKI KOZLEMENYEK, No 1, 1977, pp 41-50.
4. V. Szekely and K. Tarnay: "TRANZ-TRAN 3/A--A New Circuit Analysis Program for Small Computers," PROCEEDINGS OF THE THIRD INTERNATIONAL SYMPOSIUM ON NETWORK THEORY, Sep 1975, Split, pp 351-358.
5. Dr V. Szekely, Dr K. Tarnay, M. Rencz and P. Baji: "TRANZ-TRAN 3--A New Circuit Analysis Program System for TPA Computers," publications of the 1975 Conference of Programming Systems, 1975, Szeged, pp 497-509.
6. V. Szekely and K. Tarnay: "Accurate Algorithm for Temperature Calculation of Devices in Nonlinear Circuit Analysis Programs," ELECTRONICS LETTERS, No 19, 1972, pp 470-472.
7. V. Szekely: "Accurate Calculation of Device Heat Dynamics; A Special Feature of TRANZ-TRAN Circuit Analysis Program," ELECTRONICS LETTERS, No 6, 1973, pp 132-134.
8. Dr K. Tarnay and Dr V. Szekely: "The TRANZ-TRAN 2 Circuit Analysis Program," University Notes, Textbook Publishers, Budapest, 1975.

HUNGARY

BRIEFS

COMPUTERS STATISTICS--The 1978 Computer Technology Yearbook published by the National Computer Technology Applications Bureau of the Central Statistical Office presents an interesting overview of the number of computers in Hungary and the uses to which they are put. As of 31 December 1976, there were 454 computers in Hungary; a year later there were 521, a 14.8 percent increase. The number of small computers increased from 272 to 322, medium machines from 133 to 150. Of the computers, 323 or 71.1 percent operated in Budapest in 1976; in 1977 the ratio had increased to 74.3 percent. In 1977 26.6 percent of machine hours were used for management work; 13.2 for stock management; 8.3 percent for scientific calculations; 7.2 percent for control of production; 6.6 for statistical work. In the same year, 3.3 percent of machine hours were used for training and 3.6 percent for technical construction calculations. [Text] [Budapest NEPSZABADSAG in Hungarian 11 Oct 78 p 10]

CSO: 2502

SPACE RESEARCH PROGRAM OUTLINED

Warsaw Domestic Television in Polish 1830 GMT 25 Oct 78 LD

[Excerpt] Let us recall that 50 research centers and 8 ministries participate in the Polish space research program. The main trend is the study of the resources of the earth and of the oceans with the use of space techniques--so-called teledetection. The subjects of research include problems of space medicine, which is recognized today in the world as one of the specialties of Polish science, and also the so-called space technologies which make it possible to obtain under conditions of weightlessness--among other things--semiconducting materials of great similarity and of excellent crystal construction. Astronomy from beyond the atmosphere, developed with the aid of space techniques, enables Polish scientists to study the processes of the evolution of the universe. A scientist comments on the research program:

[Unidentified scientist] Up to a certain extent we have completed the state of individual research, let us say, the stage of heroic research which was crowned by the Polish flight, and next we will proceed to the next stage which will be more complicated, a stage which could be called industrial. In other words, we are already preparing to produce and build certain things in space. This is one part of our task. The second part is a basic theoretical one, that is, the study of the properties of the substances in space. And the third very important part is the use of space for the study of the earth. This is very beneficial in all the spheres of the country's economy--agriculture, meteorology, navigation, health, physics, technology, everything.

[Announcer] An important section of space technology is satellite communication. The station in Psary provides telephone communications with Moscow, Sofia, Havana and Ulaanbaatar, and is also a link in the Madrid-Havana line. It takes part in the everyday exchange of the news for Intervention, which we see in the news bulletins. It took part in the broadcasting, with the aid of the Molnya satellites, of television reportage from the Soyuz-30. It is expected that in the future satellite communications will be widely used by our merchant and fishing fleets.

CSO: 2602

YUGOSLAVIA

TECHNICAL DATA ON KRSKO NUCLEAR POWER STATION

Belgrade TEHNIKA in Serbo-Croatian No 6, 1978 pp 882-886

[Article by Milorad Kapor: "The Krsko Nuclear Power Plant"]

[Text] 1. Basic Information--Introduction

At a time of ever-increasing needs for energy in all fields of the economy and society, the construction of a nuclear power plant at Krsko, the first in Yugoslavia, started in early October 1974.

According to data on discovered deposits of coal, oil and gas, and on the expectations for finding new deposits, it can be concluded that these energy sources are limited and insufficient in relation to energy needs.

Ore deposits containing uranium (U_3O_8) indicate that the energy value of these raw materials in the world is considerably higher than the reserves of conventional fuels.

In Yugoslavia, the energy value of the uranium-bearing ores is approximately equal to the energy value of coal.

According to the statistical data of the United Nations and the studies on the development of nuclear energy made within the framework of the U.S. Atomic Energy Commission, the share of nuclear power plants in the production of electric energy for the 1950-2000 period, the following is stated and evaluated as follows:

Table 1

	Year			
	1950	1970	1980	2000
Share of nuclear power plants in installed capacity, in percents	0.0	2.0	15	50
Share of nuclear power plants in production, in percents	0.0	2.0	20	65

The studies for the period 1970-1980, carried out within the framework of the International Atomic Energy Commission, Vienna, Austria, indicate that 40 percent of all the new power plants in the developed countries will be nuclear powered.

The same data for developing countries for the same period is predicted at 20 percent.

Starting with the cited facts, it can also be seen that considerable nuclear power plant capacities must be in operation.

2. Choice of the Nuclear Power Plant Systems

The limited choice consisted of four reactors of the three large companies, i.e., the two types of PWR (pressurized water reactor), and BWR (boiling water reactor).

The electric power system, transmission network and connections with the adjacent systems, conditioned the choice of the PWR nuclear system for steam production and its capacity of 632 MW. This is the LW (light water)-PWR type reactor with the superheated water as a moderator and coolant.

The reactor core is filled with nuclear fuel--uranium oxide pellets located inside the zirconium tubes. There are 225 such elements, 20 of which are controlled elements. Water in the reactor flows from below and upwards through the fluid fuel elements. The heat generated in the core is transferred into the steam generators by the demineralized water injected by the main pumps.

The supply pumps of the secondary section supply water to the secondary side of the steam generator where it is heated to the boiling point and transformed into steam.

The steam so produced is sent to the turbine, and the cooled water from the reactor's core is returned to the core for a new quantity of heat.

The reactor cooling system is separated from the steam system and the water supply system, thus radioactivity is limited to the closed reactor system and direct auxiliary equipment.

The reactor is located inside a two-layer protective jacket. The first layer is made of steel and the second, of reinforced concrete, and both comprise the reactor building.

3. The Choice of Location

The location of the "Krsko" Nuclear Power Plant was determined on the basis of the criterion that a nuclear power plant should be as close to the centers of consumption as possible, to have running coolant water, good conditions for connecting into an electro-power network, good transport facilities during the construction stage, the characteristics of a micro-location for conventional electric power installations, and favorable conditions from a seismologic and geologic standpoint. It is located on the left bank of the Sava River, 3 kilometers from the town of Krsko. It is between the Zagreb-Ljubljana railroad line and the Sava River. The location belongs to the eight earthquake zone, by the ISC [International Seismological Center].

In the site area, the alluvial deposits 8-12 meters thick rest on a foundation of a more recent Tertiary layer.

According to observations from 1913 until now, the flow characteristics of the Sava River near Krsko are as follows:

- average flow, 234 m³/s
- average minimal flow, 70.40 m³/s
- lowest flow, 30 m³/s
- average highest flow, 1,705 m³/s
- highest flow, 3,053 m³/s
- average annual temperature, 11° Centigrade

The total required quantity of coolant water of 25-30 m³ for the operation of the nuclear power plant is provided by the Sava River, along with the construction of a dam for coolant water with the necessary installations.

4. Cost of Construction, Investors and Contractors

The specific nuclear equipment and the required level of operational safety, among other things, cause the construction of the nuclear power plant to be more expensive in comparison with the construction of a conventional thermoelectric power plant. This ratio ranges from 1.5 : 1 to 2 : 1.

The individual stages of work in the structure of the total investments in the construction of a nuclear power plant relative to a thermoelectric power plant, expressed in percentage, are approximately as follows:

--the construction share with preparatory work	appr. 14 percent (10.3%)
--equipment, including transportation to the construction site	appr. 59 percent (56%)
--customs duties	appr. 9 percent (14.6%)
--equipment installation	appr. 6 percent (11.7%)
--first charging with fuel	appr. 8 percent (---%)
--others	appr. 4 percent (7.4%)

The ratio of the costs of fuels for a nuclear power plant, comparing with the costs of fuels for a thermoelectric power plant, is between 1 : 3 to 1 : 4 in favor of nuclear power plant.

The agreement between the American Westinghouse Company, Electroprivreda of Zagreb and the Sava River Power Plants of Ljubljana, on the construction of the Krsko Nuclear Power Plant was signed on 22 August 1974. The Socialist Republic of Croatia and the Socialist Republic of Slovenia each share 50 percent in the total investments ranging today about 1,250 billion old dinars.

The agreement includes a set of facilities of the primary and secondary sections of the nuclear electric power plant. For the part of the facilities outside this set the investor made an agreement with the contractors without the mediation of the Westinghouse Company.

The "Hidroelektra" enterprise of Zagreb and the "Gradis" enterprise of Ljubljana are charged with the construction portion of the very responsible and extensive task of constructing the nuclear power plant. The "Djuro Djakovic" enterprise of Slavonski Brod and "Hidromontaza" enterprise of Maribor were commissioned to do the equipment installation portion of this task.

The coordination of the construction is to be carried out by the American Westinghouse Company, and the investor under the name "Nuclear Power Plant in Formation."

5. The Construction Work

The primary facilities with the nuclear equipment are treated separately in relation to the secondary facilities done with conventional means of execution and control. The structure and the present status of the work

will be presented on each of these groups. A certain amount of preparatory work was carried out for both groups of work, and this will also be the starting point for a more complete presentation of the execution of the construction work.

5.1 Preparatory Work

This work was mainly carried out in the period from October 1974 to mid-year 1975. The following items are among the more significant:

- housing for workers, capacity 1,500 workers,
- business and administrative offices for all the participants in the construction area 3,500 m²,
- customs storage area, both enclosed and open area 55,000 m²,
- service roads to the construction site and inside it, 6 kilometers long,
- 110/10 KV transformer station,
- electric power distribution net and the installation of 12 switching substations of 10/04 KV each,
- fuel pumping station for machinery and vehicles,
- auxiliary installations and auxiliary projects at the construction site,
- water supply system, with the wells to supply the construction site with water, 4,100 meters long,
- sewer network for waste water, 2,400 meters long,
- equipment for recovery of waste water at the construction site and workers' quarters, 3 units.

The excavation of a construction pit, quantity 230,000 m³, and the construction of a protective clay/concrete sheilding of 8,400 m², were a direct condition for starting with the foundation laying of the primary and secondary projects carried out up to a depth of 20.70 meters relative to the highest point of the terrain.

From a technological point of view of the excavation of a construction pit, three different layers were processed, as follows:

- layer of naturally moistened gravel to the level of subterranean water,
- layer of the gravel in the subterranean water to the limit of the pulverized marl,
- marl layer to the lowest sector of the foundation.

During the entire excavation time, atmospheric water, the subterranean water "trapped" by the cofferdam, and negligible quantities of water flowing through the cofferdam structure, were being pumped.

The solution for the diaphragm was selected with the aid of the so-called clay/concrete antifiltration screen with waterproof characteristics, while the role of the capacity is left dependent on the determined volume of the terrain at the back of the cofferdam.

The Construction Site of the Krško Nuclear Power Plant

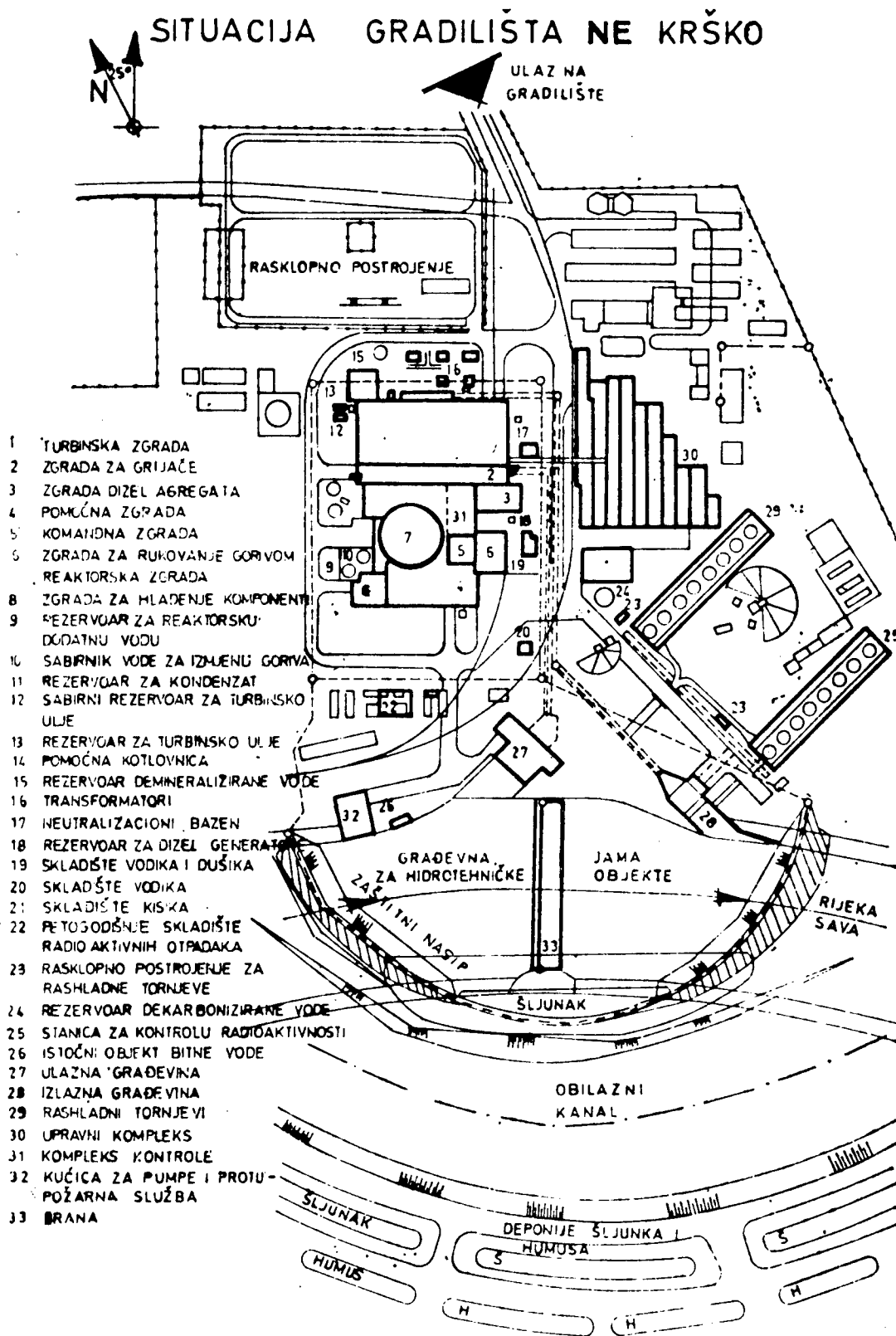

Sl. 1 — Situacioni plan gradilišta NE Krško

Figure 1. Site Plan of the Construction Site of the Krško Nuclear Power Plant
(for words within the above Figure 1 see next page; from top to bottom)

Key to Figure 1

- | | |
|---|--|
| 1. Turbine building | 18. Tank for the diesel generator |
| 2. Building w/heaters | 19. Storage for hydrogen & nitrogen |
| 3. Building w/diesel aggregates | 20. Storage for hydrogen |
| 4. Auxiliary building | 21. Storage for oxygen |
| 5. Control room building | 22. Five-year "pig" for storage of
radioactive wastes |
| 6. Building for fuel handling | 23. Opening installation for the
cooling towers |
| 7. Reactor building | 24. Tank for decarbonized water |
| 8. Building for cooling the components | 25. Radioactivity control station |
| 9. Tank for the reactor's supplemental
water | 26. Outlet for main water supply |
| 10. Water collector for fuel exchange | 27. Intake structure |
| 11. Tank for condensate | 28. Outlet structure |
| 12. Collector tank for turbine oil | 29. Cooling towers |
| 13. Tank for turbine oil | 30. Administration facility |
| 14. Auxiliary boiler room | 31. Control facility |
| 15. Tank for demineralized water | 32. Housing for the pumps and the
fire-fighting service |
| 16. Transformers | 33. Dam |
| 17. Neutralization basin | |

Words within Figure 1., as follows:

<u>Serbo-Croatian</u>	<u>English</u>
--ulaz na gradiliste	--entrance to the construction site
--rasklopno postrojenje	--disassembly installation
--gradevna jama za hidrotehnicke objekte	--construction pit for hydro- technical projects
--zastitni nasip	--protective embankment
--Rijeka Sava	--The Sava River
--sljunak	--gravel
--obilazni kanal	--detour canal
--deponje sljunksa i humusa	--deposit for gravel and humus
--sljunak	--gravel
--humus	--humus
--s (sljunak)	--gravel
--h (humus)	--humus

From the standpoint of statics, the cofferdam is a two-sided flat-pressed core in which bending moments occur depending on the movements generated and the diaphragm's rigidity. The diaphragm measures $2 \times 192 + 2 \times 144$ meters, is 13 meters deep and has a designed thickness of 50 centimeters. The lower part of the diaphragm is located 3 meters deep in the dusty, permeable marl.

Significant work, within scope of the preparatory work, represent also the evening up of a flat construction site area with a surface of $185,000 \text{ m}^2$ where all the auxiliary facilities are located and where the major part of the primary and secondary facilities are being built, Figure 1.

5.2 Laying a Foundation for the Main Facilities

All of these facilities are based on the marl terrain at the depth of from 20.70 to 16.70 meters in relation to the working high point of the terrain of 100 meters.

Before laying the foundation, a gravel fill of a total height of approximately 1 meter was made in the layers on the flat and undisturbed marl surfaces of the wide excavation-construction site pit.

Each of the layers of the fill, 20 centimeters thick, were vibrated and compressed with a roller of a certain weight and vibration. It was important to obtain a uniform and homogeneously compressed fill in its entire depth.

Dry volumetric weights of the fill range from 2.3 to 2.5 kp/cm^2 , while the range of the specific weight is approximately 2.75 kp/cm^2 .

The optimal moisture of the fill is within the limits of 4 to 5 percent.

The degree of compactness is controlled in every layer by means of volumetric dry weight and the Proctor method.

The laying of the foundation of the facilities is carried out on the prepared and undisturbed gravel fill covered with a layer of the leveled concrete 15 cm thick with waterproofing with adequate protection.

The foundations are made of type MB-300 heavy reinforced-concrete slabs, reinforced by ribbed reinforcements over 25 mm in cross section.

The fill around the foundation is of gravel made according to the same criterion as the gravel fill beneath the foundation.

The sketch of the construction-site pit for the foundation of the primary facilities indicates the lowest points of the wide excavation, the inclinations of the slope, the limit of the natural gravel layers and marl, and the position and depth of the clay/concrete cofferdam--the protection against subterranean water during the construction.

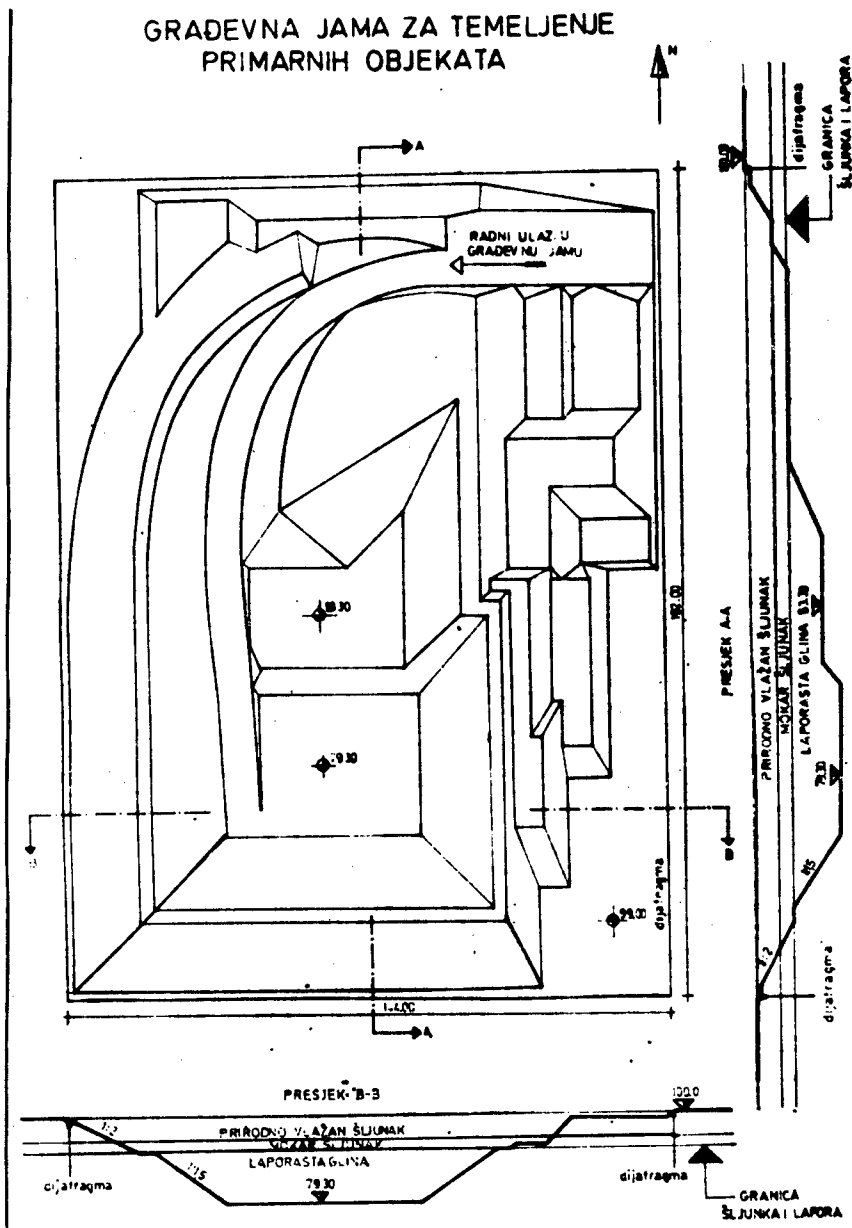

Figure 2. Construction Pit for the Foundation of the Primary Facilities
(for the words within Figure 2 see next page)

Serbo-Croatian

English

Radni ulaz u gradevnu jamu	working entrance into the construction pit
dijafragma	diaphragm
presjek	cross section
prirodno vlazan sljunak	naturally moistened gravel
mokar sljunak	wet gravel
laporasta glina	marly clay
granica sljunka i lapora	limit of gravel and marl

5.3 Primary Facilities

These are the facilities which simultaneously comprise the nuclear part of the power plant:

- the reactor building in which the 632-MW capacity reactor and two steam generators are located,
- auxiliary building,
- connecting building,
- control room building,
- cooling building,
- fuel building,
- diesel-generator building
- water treatment building.

It is necessary to build the following materials into these projects:

--MB-300 concrete and reinforced concrete	92,000 m ³
--concrete ribbed steel	10,200 tons
--sealing	145,000 m ²

No chemical components are used as additives in the concrete and reinforced concrete under any conditions of cement-making. The heating of concrete is carried out under the winter conditions of cement-making. While preparing them in the cement mixer, all the components of concrete are heated, except the cement.

The elements which the concrete is being built in to are closed temporarily and are heat treated before and after the cement work.

The construction work on the primary facilities are in their final stage and their final completion is expected early Spring 1978. This fact is shown in Figure 4.

The Site Plan for Primary Facilities

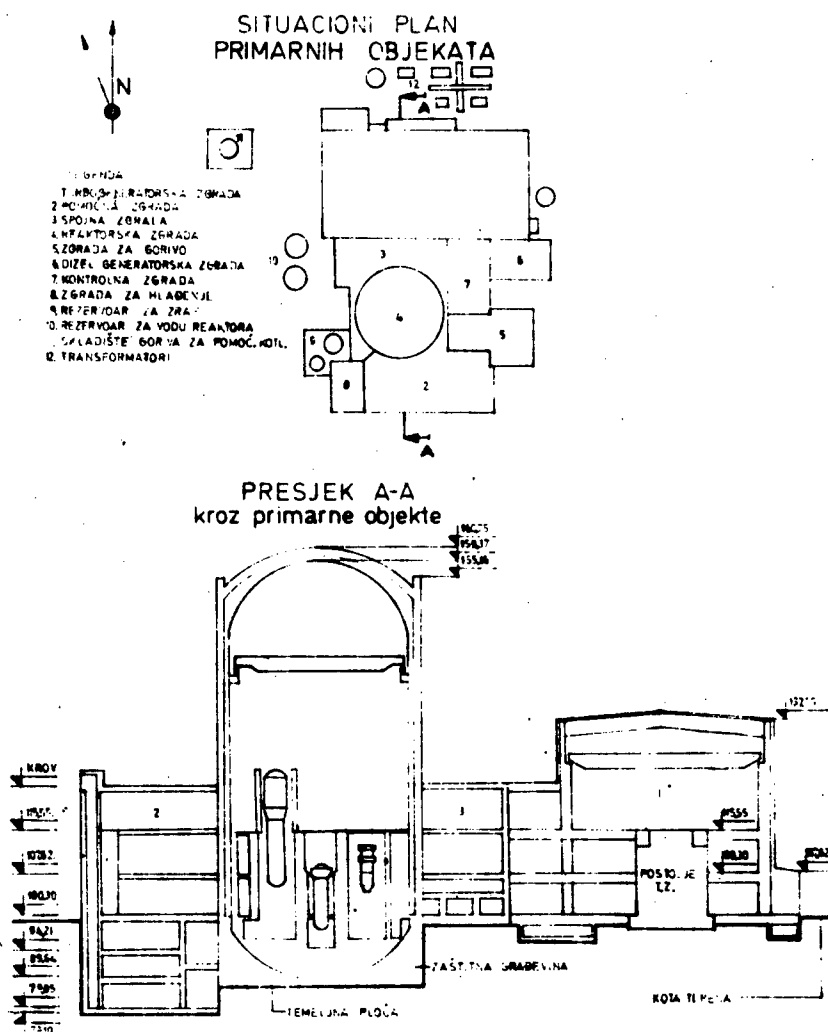

Figure 3

Key:

- | | |
|------------------------------|--|
| 1. Turbogenerator building | 7. Control room building |
| 2. Auxiliary building | 8. Cooling building |
| 3. Connecting building | 9. Air tank |
| 4. Reactor building | 10. Reactor water tank |
| 5. Fuel building | 11. Fuel storage for auxiliary boiler room |
| 6. Diesel generator building | 12. Transformers |

(words within Figure 3, as follows):

<u>Serbo-Croatian</u>	<u>English</u>
krov	roof
temeljna ploča	foundation slab
zastitna gradevina	protective structure
postolje T.Z.	Support of the turbogenerator building
kota terena	peak elevation of the terrain

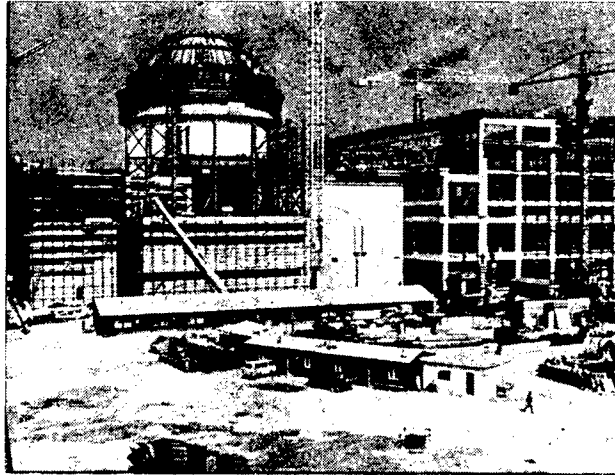

Figure 4. The Primary and a Part of Secondary Facilities Under Construction

5.4 Construction Characteristics of the Primary Facilities

The reactor building is the most significant of these facilities. The sketch, the site plan of the primary facilities with a characteristic cross section shows the reactor building as the most striking among the other facilities.

The reactor building consists of the two cylinders with cupolas. The inner one is made of steel and the outer one of reinforced concrete. The cylinders are separated by an air space, and only in their lower part--the foundations--are they connected with prepared concrete.

The steel part of the cylinder consists of the following:

- torispherical bottom of a 22-meter radius,
- the cylindrical mantle of a 32-meter side diameter,
- a spherical cupola of 16 meters in radius.

The total height of the steel cylinder is 70 meters, and its weight, 2,700 tons. The steel is imported and the quality is in accord with the American standards, ASME SA-516 Gr 70.

The thickness of the sheet metal in the cupola is approximately 2 cm, and 3.8 cm in the mantle. The outer reinforced concrete cylinder with a 35-meter inside diameter consists of the following:

- MB-300 reinforced concrete foundations with a total of 10,600 m³ of built-in concrete and ribbed reinforcement steel of 1,140 tons,
- MB-300 reinforced-concrete mantle with approximately 5,000 m³ of concrete and 1,300 tons of ribbed reinforcement steel.
- MB-300 reinforced-concrete cupola with approximately 800 m³ of concrete and 100 tons of steel reinforcement.

There is a fill of pre-packed concrete of approximately 950 m³ between the foundations of the outer and inner cylinders.

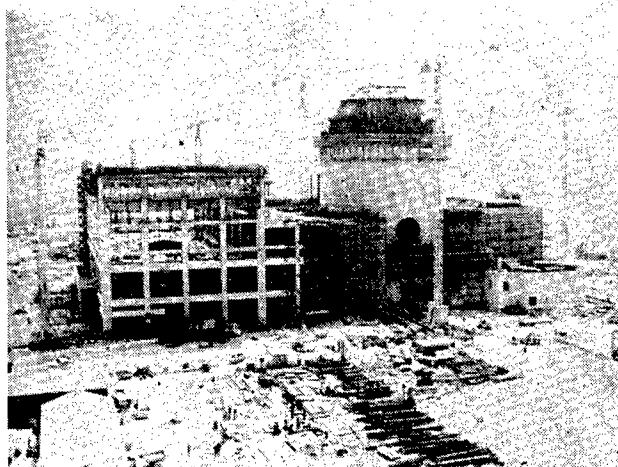

Figure 5. Turbogenerator Building, Reactor Building and the Auxiliary Facilities Under Construction

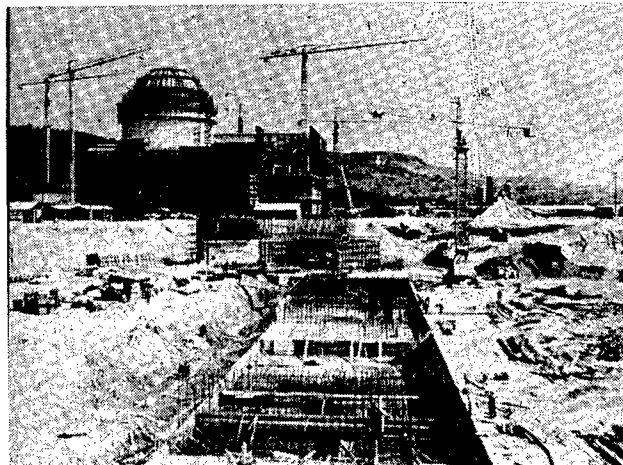

Figure 6. The Facilities Under Construction on the Sava River, With a View Toward the Nuclear Part of the Power Plant

The inside diameter of the casing is approximately 17.5 meters with a wall thickness of 0.75 meters. The cupola has a radius of approximately 22.5 meters and a casing thickness of approximately 0.60 meters.

5.5 Secondary Facilities

It is possible to predict the final completion of these projects for the end of April 1978, in view of the present level of construction.

These projects consist of the following:

- turbogenerator building,
- canals for supply and removal of coolant water,
- foundations and flat site for the disassembly installations,
- intake structure for the supply of coolant water,
- outflow structure for the removal of spent coolant water,
- dam on the Sava River.

The following materials will be built into these projects:

- | | |
|------------------------------------|------------------------|
| --concrete and reinforced concrete | 75,000 m ³ |
| --ribbed reinforcement steel | 8,000 tons |
| --weatherproofing | 102,000 m ² |

Except for the Sava River Dam, the same conditions of concrete work are applied for all mentioned projects as for the primary facilities.

The status of the work on these projects is shown in Figures 5 and 6.

Before the work on the hydrotechnical projects noted in the group of secondary facilities (the Sava River Dam, intake structure, outflow structure), a series of auxiliary operations was performed. The most important of these are as follows:

- A canal for a temporary diversion of the Sava River where 370,000 m³ of earth material were excavated.
- The construction pit of the dam with the upstream and downstream barrier-type embankments of the Sava River bed where approximately 40,000 m³ of embankment was built and 60,000 m³ of earth excavated.
- Clay/concrete cofferdam for the protection of the construction pit of the dam, approximately 11,000 m².
- Reinforced concrete cofferdam downstream, alongside the dam bed, 1,300 m².
- Stone covering--the protection of the Sava River bed downstream from the construction pit of the dam, as well as a partial lining of the canal for diverting the Sava River bed. Here, over 20,000 m³ of stone of various sizes and weight were built up.
- A wide excavation in the construction pit for the dam, intake and outflow structures, the part of the canal for removal and supply of water, a building for water treatment, and supporting walls securing the left bank of the Sava River on which side, in the immediate vicinity, the Krsko Nuclear Power Plant is located. This work was performed in the second half of 1976 and the first quarter of 1977.

5.6 Other Facilities

The following facilities are in the final stages of construction:

- an access road, approximately 3.2 km long,
- an industrial railroad track, 3 km long,
- a protective high water levee of the left bank of the Sava River, approximately 3 km long,
- main waterworks for drinking water supply.

The projects to be started this year are:

- cooling towers,
- auxiliary boiler room next to the turbogenerator building with stack,
- administration building,
- service building,
- garages,
- permanent traffic arteries at the construction site.

The deadlines for the construction of these projects are very short, so it is possible to be confident that all the construction work, including that mentioned previously, will be completed in 1978.

6. Equipment for Construction Work

6.1 Machinery and Installations

Earthmoving work was performed, or is being performed, with the use of almost all kinds of bulldozers, dredges, graders, rollers, vibrator plates, and the like.

The practical effects of the bulldozers range from 30 to 180 m³/hour for excavations, and 60 to 450 m³/hour for distributing the material.

Entirely automatic installations are used for concrete making--cement mixers of a practical capacity of 15 to 50 m³/hour.

The construction site has available a total theoretical capacity of concrete-making installations of 160 m³/hour. Concrete pouring is carried out exclusively with stationary and automatic pumps of sufficient capacity for the cement mixers.

6.2 Transportation

The internal transportation of various materials and transportation to and from the construction site is done with trucks and truck-trailers with a capacity of 16 to 40 tons. Loading of surface materials is carried out by loaders of capacities of 60 to 160 m³/hour. All vertical transport is carried out with tower cranes with considerable vertical and horizontal reach. Automatic self-propelled cranes of up to 75 tons capacity also play a great part in both vertical and horizontal transport.

7. Main Construction Materials

7.1 Cement

In accordance with the importance of the facilities and the required quality of concrete, cement from the Anhovo Cement Plant and the Plant Podsused "Sloboda" are used, and sometimes "Dalmacija Cement" from Split is used as a substitute for the "Anhovo" cement.

The total needs for cement for the construction of all the facilities is estimated at approximately 55,000 tons.

7.2 Gravel and Sand

The total quantities of the granulated mix for the production of concrete are estimated to be approximately 220,000 m³. These quantities are mainly secured by the nearest gravel site, IGM "Sava" at Krsko.

7.3 Reinforcement Steel

The "Zenica" Ironworks assumed complete production and delivery of approximately 18,000 tons of the ribber reinforcement steel of various cross-sections up to 36 mm and the required quality.

7.4 Sealing and Wood Building Materials

Except for the specially constructed scaffold and sealing for the cupola of the reactor building, all other sealing and wooden building material is standard, from the standpoint of modern civil engineering.

8. Coordination of Installation and Construction Work

The installation work started almost at the same time as the construction work. Such work method conditioned practically day-to-day coordination between the contractors of both operations.

The basis for coordination was the detailed operational plans and their everyday execution.

9. Construction Deadlines

The usual difficulties that appear in the construction of all more important projects, are present also in the construction of our first nuclear power plant, despite maximum involvement by the investors and contractors in their execution of everyday operations. The progress curve of the delivery of the completed documentation often did not follow the possible progress curve of work performed.

Due to these usual difficulties, it can be concluded that the current delay is approximately 5-6 months relative to the agreed upon plan deadline.

Almost the same difficulties are also present among the contractors of the installation work. Therefore, there is little hope that the nuclear power plant will go into operation in April 1979, as scheduled in the Agreement.

Most probably, the first KWh of electric power from the Krsko Nuclear Power Plant will be obtained by the end of 1979, at which time the total delay will be approximately 8 months.

10. The Production of Electric Power and Safety of Operations

When put into operation, our first nuclear power plant of 632-MW capacity at optimal production (with 80 percent capacity) will be able to generate 4.4 billion KWh annually.

The transmission of the generated electric power will be possible through connection into the power grid, i.e., the 380-KV network.

The safety of operations is based on the three safety levels of the nuclear part of the power plant, as follows:

--A system for shutting down the reaction, activated independently through several separate "safety rods," a control system, a spare cooling system, and a secure source of electric energy for the major installations.

--The reactor design, where complex and independent testing of materials and components was carried out before the construction and in the course of operation. The reactor of the "Krsko" Nuclear Power Plant is the 100th such reactor installed in the world having the same technical characteristics,

--Two protective casings, steel and reinforced concrete, comprising the reactor building, for a level of radiation protection against the "maximum credible accident" in the nuclear power plant operation.