



NAVAL FACILITIES ENGINEERING SERVICE CENTER  
Port Hueneme, California 93043-4370

**Contract Report**  
**CR 00-001-SHR**

**FINAL REPORT**  
**PHASE 1 - CONCEPT DEVELOPMENT**  
**MODULAR HYBRID PIER (MHP)**

An Investigation Conducted by

BERGER/ABAM Engineers, Inc.  
Federal Way, Washington 98003-2600

February 2000

**20000301 043**

Approved for public release; distribution is unlimited.



REPORT DOCUMENTATION PAGE			Form Approved OMB No. 0704-018	
Public reporting burden for this collection of information is estimated to average 1 hour per response, including the time for reviewing instructions, searching existing data sources, gathering and maintaining the data needed, and completing and reviewing the collection of information. Send comments regarding this burden estimate or any other aspect of this collection information, including suggestions for reducing this burden, to Washington Headquarters Services, Directorate for Information and Reports, 1215 Jefferson Davis Highway, Suite 1204, Arlington, VA 22202-4302, and to the Office of Management and Budget, Paperwork Reduction Project (0704-0188), Washington, DC 20503.				
1. AGENCY USE ONLY (Leave blank)	2. REPORT DATE February 2000		3. REPORT TYPE AND DATES COVERED Final; Oct 1998 through Sep 1999	
4. TITLE AND SUBTITLE FINAL REPORT PHASE 1-CONCEPT DEVELOPMENT MODULAR HYBRID PIER (MHP)			5. FUNDING NUMBERS	
6. AUTHOR(S) BERGER/ABAM Engineers, Inc.				
7. PERFORMING ORGANIZATION NAME(S) AND ADDRESS(ES) BERGER/ABAM Engineers, Inc. Federal Way, Washington 98003-2600			8. PERFORMING ORGANIZATION REPORT NUMBER CR 00-001-SHR	
9. SPONSORING/MONITORING AGENCY NAME(S) AND ADDRESSES Naval Facilities Engineering Service Center 1100 23rd Avenue Port Hueneme, CA 93043-4370			10. SPONSORING/MONITORING AGENCY REPORT NUMBER	
11. SUPPLEMENTARY NOTES				
12a. DISTRIBUTION/AVAILABILITY STATEMENT Approved for public release; distribution is unlimited.			12b. DISTRIBUTION CODE	
13. ABSTRACT (Maximum 200 words)  The purpose of this project was to develop a new class of pier facilities that provide the highest level of operational advantages and maintenance reduction while maintaining capital costs that are comparable to current Navy berthing pier construction. The objective was to take maximum practical advantage of recent advances in the economical use of fiber-reinforced plastic (FRP) composites in civil engineering structures. It was perceived that this new technology represented an important opportunity for more durable Navy waterfront facilities.  This report documents the evaluation of attractive configurations and construction concepts for a new generation of Navy piers, investigation of innovative applications of FRP composite materials, and studies on the use of light-weight concrete in pier construction.				
14. SUBJECT TERMS Modular hybrid pier, concept development, berthing, pier facilities, fiber-reinforced plastic, concrete			15. NUMBER OF PAGES	
			16. PRICE CODE	
17. SECURITY CLASSIFICATION OF REPORT Unclassified	18. SECURITY CLASSIFICATION OF THIS PAGE Unclassified	19. SECURITY CLASSIFICATION OF ABSTRACT Unclassified	UL	

## EXECUTIVE SUMMARY

The purpose of this project was to develop a new class of pier facilities that provide the highest level of operational advantages and maintenance reduction while maintaining capital costs that are comparable to current Navy berthing pier construction. The objective was to take maximum practical advantage of recent advances in the economical use of fiber-reinforced plastic (FRP) composites in civil engineering structures. It was perceived that this new technology represented an important opportunity for more durable Navy waterfront facilities.

This report documents the evaluation of attractive configurations and construction concepts for a new generation of Navy piers, investigation of innovative applications of FRP composite materials, and studies on the use of lightweight concrete in pier construction.

As an extension of the Naval Facilities Engineering Service Center's (NFESC's) development of a new class of pier repair and upgrade methods using FRP composites, an investigation into the potential of using these materials for the construction of long lasting replacement Navy pier facilities was commissioned.

Three construction concepts were investigated:

- Structural Concept 1 – Baseline Structure – Conventional Pile-Supported Double-Deck Pier
- Structural Concept 2 – Off-Site Prefabricated Float-In, Pile-Supported Modular Pier
- Structural Concept 3 – Off-Site Prefabricated Permanently Floating Pier

A double-decked, highly compartmentalized floating pier constructed of FRP/concrete hybrid plates and slabs is recommended. The pier concept also maximizes the use of low maintenance systems and secondary structures made from FRP composite materials. This concept provides a number of important benefits, including:

- High level of watertight compartmentalization – providing safety against sinking, even in the event of compartment breach by damage.
- Constant ship-to-pier interface throughout the full tidal cycle – eliminating the need for mooring line tending and changing ship-to-shore cargo handling configurations.
- Constant ship-to-fender system relationship – greatly reducing potentially damaging relative motions between the ship surface and the fender system.
- Separation of working deck space and utilities, lines, and cables – making deck operations more efficient and safe.
- Improved ship service utility systems – systematized to better accommodate the unique requirements of specific vessels.

- Ship's crew amenities included as part of the pier interior space development – providing crew shore-side needs (laundry, recreation, and vending/service) immediately adjacent to the berthed vessel.
- Greatly reduced pier maintenance requirements through the use of long lasting noncorroding materials.
- Significant reduction in life-cycle cost as a result of longer economic life and reduced maintenance over the life of the facility.

The Off-Site Prefabricated Permanently Floating Pier concept was chosen because it offers the possibility of a non site-specific “standardized” design and the opportunity of repetition in construction to an extent not possible with any of the other concepts. This fact offers the potential for standardization of utility and subsystem designs that can be efficiently configured to support the surface combatants to be berthed. These pier facilities could then be exactly the same for each installation. The selected concept also provides for fender system standardization that is exactly the same from installation to installation. In addition to potential substantial cost savings, this standardization should pay benefits in maintenance, training, and operational optimization over time. This approach also makes several “reoutfittings” of a pier, to accommodate major vessel technology changes, economically viable over the life of the pier.

Use of FRP reinforcing mesh and lightweight concrete combined with proven prestressing technology makes substantial material quantity savings possible in a floating structure, when compared against previous state-of-the-art floating designs and pile-supported structures. This combination of materials has the potential of both economy and long-term durability.

It appears that the hull plating design for a permanently floating pier is a good candidate for optimization using FRP/concrete composite concepts. A mathematical model for element design has been developed that will be compared to actual test results in Phase 2.

In addition to the proposed use in primary structures, FRP products have been used on commercial marine structures, including piers and wharves and offshore drilling structures, as secondary structure and utility-related features. It is felt that this experience can be easily transferred to Navy facilities.

## CONTENTS

	Page
<b>SECTION 1 INTRODUCTION .....</b>	<b>1</b>
1.1 Overview of the Program .....	1
1.2 Background .....	2
1.3 Phase 1 Scope of Work .....	3
<b>SECTION 2 OBJECTIVES OF THE PHASE 1 PROGRAM .....</b>	<b>5</b>
2.1 Operational Objectives .....	5
2.2 Operational Flexibility Objectives .....	6
2.2.1 Modularity .....	6
2.2.2 Utility/Systems Flexibility and Update Ability .....	6
2.3 Technology Application Objectives .....	6
2.4 Cost Objectives .....	7
<b>SECTION 3 PHASE 1 PROJECT TEAM ROLES .....</b>	<b>8</b>
<b>SECTION 4 EXECUTION OF THE PHASE 1 PROJECT .....</b>	<b>9</b>
4.1 Kickoff Meeting .....	9
4.2 Mission for Phase 1 Program .....	9
4.3 Quantification of Operational Requirements .....	9
4.4 Evaluation of Fixed versus Floating Piers .....	9
4.5 Preliminary Operational Configuration .....	9
4.6 Evaluation of Composite Technology Suited to Purpose .....	9
4.6.1 Interaction with Composites Institute .....	10
4.6.2 Development of Design Philosophy/Methodology .....	10
4.6.3 Review of Composite Material Requirements .....	10
4.6.4 Review of Lightweight Concrete Requirements .....	10
4.7 Refinement of Design Method .....	10
4.8 Review of Appropriate Mooring Concepts .....	11
4.9 Estimation of Preliminary Project Costs .....	11
4.10 Definition of Phase 2 Scope of Work .....	11
<b>SECTION 5 PREVIOUS WORK RELATED TO THIS PROJECT .....</b>	<b>12</b>
5.1 Previous Work by NCEL and Navy on Floating Piers .....	12
5.2 Previous Work by Project Team Members .....	12
5.3 Composites Research and Development Applicable to this Project .....	12
5.3.1 NFESC Work .....	13
5.3.2 University of Wyoming Work .....	13

	<b>Page</b>
<b>SECTION 6 EVALUATION OF FIXED VERSUS FLOATING PIERS .....</b>	<b>14</b>
6.1 Structural Concept 1: Baseline Structure – Conventional Pile-Supported	
Double-Deck Navy Pier .....	14
6.1.1 Description .....	14
6.1.2 Construction .....	14
6.1.3 Costs .....	14
6.1.4 Characteristics and Possibilities .....	15
6.2 Structural Concept 2: Off-Site Prefabricated Float-In, Pile-Supported	
Modular Pier .....	16
6.2.1 Description .....	16
6.2.2 Construction .....	16
6.2.3 Costs .....	19
6.2.4 Characteristics and Possibilities .....	19
6.3 Structural Concept 3: Off-Site Prefabricated, Permanently Floating	
Double-Decked Pier .....	21
6.3.1 Description .....	21
6.3.2 Construction .....	21
6.3.3 Costs .....	21
6.3.4 Characteristics and Possibilities .....	21
6.4 Recommended Structural Concept .....	23
<b>SECTION 7 DESIGN APPROACH .....</b>	<b>25</b>
7.1 Design Criteria .....	25
7.1.1 Water Depth .....	25
7.1.2 Structure Length .....	25
7.1.3 Structure Width .....	25
7.1.4 Design Freeboard .....	27
7.2 Design Loads .....	27
7.2.1 Operational Loads .....	27
7.2.2 Load Effects on Floating Piers .....	28
7.3 General Structural Design .....	30
7.3.1 Concrete Design .....	30
7.3.2 Crack Width Design Philosophy .....	31
7.4 Material Properties .....	32
7.4.1 Prestressing Tendon Properties .....	32
7.4.2 FRP Reinforcement Properties .....	34
7.4.3 Lightweight Concrete Design Properties .....	35
7.5 Approach Developed for Design of CFRP Reinforced Sections .....	35
7.5.1 Introduction .....	35
7.5.2 Design Philosophy .....	35
7.5.3 Analysis of Makizumi, Sakamoto, and Okada Paper .....	36

	<b>Page</b>
7.5.4 Assumed Material Properties for Analysis .....	37
7.5.5 Balanced Condition .....	37
7.5.6 Effect of Increasing the Prestressing .....	42
7.5.7 Cost Comparisons .....	42
7.5.8 Comparison to All-Steel Design .....	48
7.5.9 Hybrid Steel Carbon Designs .....	48
7.5.10 Discussion of Results .....	48
7.5.11 Conclusions .....	51
7.6 References .....	51
 <b>SECTION 8 DURABILITY OF FRP-REINFORCED LIGHTWEIGHT CONCRETE MARINE STRUCTURES .....</b>	 <b>53</b>
8.1 Durability Design of Marine Structure .....	53
8.2 Lightweight Concrete Technology .....	55
8.2.1 Use of Lightweight Concrete in Marine Structure – Case History .....	55
8.2.2 Microstructure Characteristics: LWC versus NWC .....	58
8.2.3 Mechanical Properties of LWC .....	59
8.2.4 Durability Characteristics of LWC .....	62
8.2.5 Evaluation of LWC Applications in Floating Structures .....	64
8.2.6 LWC Mix Proportions .....	66
8.2.7 Use of Fly Ash in LWC Mixes .....	68
8.3 Durability of CFRP Materials .....	69
8.3.1 Fatigue Strength of CFRP .....	69
8.3.2 Creep Rupture of CFRP .....	69
8.3.3 Creep and Relaxation of CFRP .....	69
8.3.4 Temperature Effects of CFRP .....	69
8.3.5 Galvanic Corrosion of CFRP .....	70
8.4 References .....	70
 <b>SECTION 9 CONCEPT DESIGN CONFIGURATION TO MEET OPERATIONAL GOALS .....</b>	 <b>72</b>
9.1 Vessels Served .....	72
9.2 Operational Space .....	72
9.3 Modularity .....	72
9.4 Prefabrication .....	72
9.5 Maintenance-Free Service .....	73
9.6 Competitive Cost .....	73
9.7 State-Of-The-Art Operation .....	73
9.8 Unlimited Crane Access .....	73
9.9 Functional Separation of Deck Operations and Utilities .....	73
9.10 State-Of-The-Art Materials Use .....	74

	<b>Page</b>
9.11 Interface with Navy-Provided Fender System Designs .....	74
9.12 Effort to Lead to a 2004 MILCON Project .....	74
9.13 Utilities .....	74
9.13.1 Utility Layouts .....	74
 <b>SECTION 10 ELEMENT DESIGN CONFIGURATIONS TO MEET STRUCTURAL REQUIREMENTS OF SELECTED CONFIGURATION .....</b>	 <b>77</b>
10.1 General .....	77
10.2 Hydrostatics .....	77
10.3 Typical Construction Details .....	77
10.4 Element Concrete Outlines .....	78
10.5 Carbon Mesh Reinforcing Use .....	78
10.6 Keel Plating Construction .....	86
10.7 Exterior Wall Plating .....	86
10.8 Interior Wall Plating .....	86
10.9 Working Deck .....	86
10.10 Utility Deck .....	87
10.11 Working Deck Support Elements .....	87
10.12 Access Elements .....	87
10.13 Other .....	88
 <b>SECTION 11 MOORING SYSTEM CONCEPT AND CRITERIA .....</b>	 <b>89</b>
11.1 General .....	89
11.2 Vessel Characteristics .....	90
11.3 Calculation of Berthing Forces .....	90
11.4 Loading Criteria for Mooring Design .....	91
11.4.1 Wind and Current Data .....	91
11.4.2 Water Depth .....	91
11.5 Mooring System Design Loads .....	92
11.6 Mooring Dolphin/Anchor Pile System .....	93
11.6.1 Anchor Piles .....	94
11.6.2 Mooring Dolphin Cap .....	95
11.6.3 Mooring Dolphin-to-Hull Connections .....	97
11.6.4 Other Guide Dolphin Mooring-Related Issues .....	98
11.7 Mooring with a Tensioned Line System .....	98
11.7.1 Materials Considered for Tensioned Line Moorings .....	98
11.8 Combined Mooring Line and Mooring Dolphin/Anchor Pile System .....	99
11.9 Combined Mooring System Incorporating Transfer Span .....	101
11.10 Conclusions .....	101
11.11 References .....	101



	Page
<b>SECTION 12 FENDERING SYSTEMS .....</b>	<b>102</b>
<b>SECTION 13 MAXIMIZING THE USE OF EXISTING FRP COMPOSITE MATERIALS FOR PIER HARDWARE AND ANCILLARY APPLICATIONS .....</b>	<b>103</b>
13.1 Low-Pressure Supply and Waste Disposal Systems .....	103
13.2 High-Pressure Supply Systems .....	103
13.3 Structural-Related Applications for FRP Composite Materials .....	103
13.4 Electrical-Related Applications for FRP Composite Materials .....	104
13.5 Miscellaneous Applications for FRP Composite Materials .....	104
13.6 Items That Could be Fabricated From Plastic .....	105
13.7 FRP Composite Component Issues .....	105
13.8 Costs of FRP Components .....	106
13.9 Communication with Composites Institute's Market Development Alliance .....	108
<b>SECTION 14 ADVANTAGES OF SYSTEMATIZED PLANNING, DESIGN, AND CONSTRUCTION FOR NAVY FLOATING PIER PROGRAM .....</b>	<b>109</b>
14.1 Status Quo in Pier Project Design and Development .....	109
14.2 Possibility of Systematized Project Approach .....	109
14.2.1 Modularity .....	110
14.2.2 Off-Site Construction .....	110
14.2.3 Standardization .....	111
14.3 Procurement Issues .....	111
<b>SECTION 15 PRELIMINARY COST CONSIDERATIONS .....</b>	<b>112</b>
15.1 Preliminary Evaluation of Project Costs .....	112
15.2 Project Cost Objectives .....	112
15.3 Materials Costs .....	112
15.4 Pier Element Costs .....	112
15.5 Systems Costs .....	113
15.6 Site-Related Costs .....	113
15.7 Life-Cycle Costs .....	113
15.8 Phase 2 Cost Estimating .....	114
<b>SECTION 16 EVALUATION OF RECOMMENDED PHASE 1 CONFIGURATION AGAINST CRITERIA .....</b>	<b>115</b>
16.1 Technical Maturity of Proposed Solutions .....	115
16.1.1 CFRP Prestressing Systems .....	115
16.1.2 CFRP Reinforcing Mesh .....	116
16.2 Technical Risk of Proposed Solutions .....	116

	<b>Page</b>
16.3 Risk Assessment for Development .....	116
16.4 Risk Mitigation Approaches for the Program .....	117
<b>SECTION 17 DEFINITION OF FUTURE PHASE ACTIVITIES .....</b>	<b>118</b>
17.1 Capability Additions for Phases 1a and 2 .....	118
17.2 Material Confirmation Requirements .....	118
17.3 Prototype FRP Component Design Requirements .....	119
17.4 Operational Requirements Refinement .....	119
17.5 Interfacing Requirements with Complementary Programs .....	119
17.6 Analytical Requirements .....	119
17.7 Element Test Requirements .....	119
17.8 Component Test Requirements .....	120
17.9 Global Test Requirements .....	120
17.10 Technical Risk Reduction Planning .....	120
17.11 Detailed Facility Cost Estimating .....	120
17.12 Industry Involvement Planning .....	120
17.13 Supplemental Funding Source Planning .....	120
17.14 Phases 2 And 3, Cost and Schedule Development .....	120
<b>SECTION 18 RECOMMENDATIONS .....</b>	<b>121</b>

### LIST OF FIGURES

Figure 6-1	Off-Site Prefabricated Float-In, Pile Supported Modular Pier – Sheet 1 .....	17
Figure 6-2	Off-Site Prefabricated Float-In, Pile Supported Modular Pier – Sheet 2 .....	18
Figure 7-1	Hydrostatic Loads .....	29
Figure 7-2	Stress Diagram .....	32
Figure 7-3	Balanced Condition Strains .....	38
Figure 7-4	Balanced Condition Stress .....	40
Figure 7-5	M- $\Delta$ Curves for “Balanced” Designs .....	41
Figure 7-6	Strains in Case 4 – Tendon Rupture Controls .....	43
Figure 7-7	Strains in Case 6 – Concrete Crushing Controls .....	44
Figure 7-8	M- $\Delta$ Curve for Case 6 .....	45
Figure 7-9	Cost Comparison .....	50
Figure 10-1	Section – Keel at Midspan .....	80
Figure 10-2	Section – Keel at Interior Bulkhead Joint .....	81
Figure 10-3	Section – Top Deck at Interior Bulkhead Joint .....	82
Figure 10-4	Section – Haunched Deck Slab with Straight Tendon .....	83
Figure 10-5	Detail – Mesh with Cut Cross Elements .....	84
Figure 10-6	Detail – Standard L and U Shapes .....	85
Figure 11-1	Mooring System for a Floating Navy Pier .....	96
Figure 11-2	Plan – Mooring System for a Floating Navy Pier .....	96

	<b>Page</b>
Figure 11-3 Elevation – Mooring System and Approach Ramp .....	97
Figure 11-4 Long Tensioned Steel Mooring Line Concept .....	100
Figure 11-5 Steel Mooring Line with Sinkers Concept .....	100

### **LIST OF TABLES**

Table 7-1 Cost Variation with Degree of CFRP Content .....	47
Table 7-2 Cost Variation for Constant Moment of 30-k-ft (40.7 KN-m) .....	47
Table 7-3 Cost Comparison of All-Steel Design .....	49
Table 7-4 Hybrid Design – Steel PT Plus Carbon Grids .....	49
Table 8-1 Cost Implications and Expected Durability of Combinations .....	55
Table 8-2 LWC Mix Proportions .....	67
Table 8-3 Test Protocol and Performance Requirements .....	67

### **LIST OF DRAWINGS**

Drawing S-1 NAVSTA Norfolk Pier 2 Replacement Typical Lateral Pier Section – VE Proposal
Drawing S-2 Floating Pier Cross Sections
Drawing S-3 Pontoon and Pier Plans
Drawing S-4 Keel/Interior Bulkhead Layout
Drawing S-5 Mooring Line Arrangement Options
Drawing S-6 Isometric Pontoon Framing

### **APPENDIXES**

Appendix A Working Group Meeting Minutes
Appendix B Description of Prince Edward Island Bridge Construction
Appendix C Computer Output
Appendix D Preliminary Estimate of Hydrostatic Characteristics of Floating Pier and Weight Estimates for CFRP
Appendix E Mooring System Design Calculations
Appendix F Pier Hardware and Ancillary Applications for FRP Composite Use (CI-MDA Input)

## SECTION 1 INTRODUCTION

### 1.1 OVERVIEW OF THE PROGRAM

The Department of the Navy, through the Naval Facilities Engineering Service Center (NFESC), at Port Hueneme, California, has initiated a research program to develop innovative technology solutions for modular hybrid pier (MHP) construction.

The purpose of the program was to develop cost competitive, long lived, lightweight, and modular structural concepts for Navy pier construction having a zero maintenance requirement for 75 years in a severe marine environment. The following additional items were considered during development:

*Vessel berthing capability* – mooring ships (CGs, DDGs, and FFGs) two abreast, providing operational space (2,400 to 2,800 feet [732 to 853 m] of berthing length), utilities and support facilities, personnel transfer, maintenance and repair, cargo transfer, crew training, waste handling, hotel, ship service utilities (water, heat, sewer, electricity, communications cables, compressed air), access facilities, fendering, crane services, mooring devices, access to external transportation, lighting, security, and fire alarm.

*Modularity* – to facilitate off-site construction and structural modification to meet changes in mission requirements over the pier's service life, including possible relocation.

*Prefabrication* – to provide a new capability and flexibility to reconfigure Navy waterfront infrastructure to meet changes in ship characteristics and force realignments.

*Maintenance-free service* – zero maintenance over a 75-year service life in a marine environment.

*Competitive cost* – initial cost to be competitive with conventional construction.

*State-of-the-art operation* – ability to function with the operational advantages of double-deck and floating piers and meet the requirements of MIL-HDBK-1025/1.

*Unlimited crane access* – for a 140-ton (1,250-kN) mobile crane while avoiding conflicts with utilities and fendering.

*Functional separation of deck operations and utilities* – to allow achievement of unrestricted working deck operations.

*State-of-the-art materials use* – use of high strength lightweight concrete, FRP reinforcements, and fault diagnostics in ways that exploit the constituent materials. Use of FRP exclusively for non-structural elements.

*Use of most effective technology* – employing American Concrete Institute, U.S. Navy (NFESC and MIL-HDBK-1025/1), Canadian, and Japanese guidelines.

*Interface with Navy-provided fendering system designs* – to be provided from Office of Naval Research Advanced Berthing System program in future phase of this program.

*Effort to lead to a 2004 MILCON project* – with appropriate attention to technical risk and fallback planning.

## 1.2 BACKGROUND

This is the first phase of a proposed multiphased program for the evaluation and development of FRP/concrete composite technologies and completely FRP composite elements to improve and extend the life of Navy pier construction. Concepts were developed with the objectives of improving pier operational function, reducing implementation schedule time, minimizing on-site construction disruption, minimizing long-term maintenance requirements, and extending the useful life of pier facilities all at a reasonable cost.

The estimated project construction costs for a typical berthing pier replacement project (e.g., MILCON P-327 at Naval Station (NAVSTA) San Diego, California) can be broken down as follows:

Structure	34% to 38%
Utilities	22% to 24%
Fendering	6%
Other works and contingencies	32% to 38%

This capital cost only represents part of the financial picture. In addition, potential life-cycle costs for maintenance of the components should be estimated. Net present value for future maintenance of under-pier gravity lines alone has been estimated at \$2 million in a recent value engineering (V/E) exercise (e.g., P-355 NAVSTA Norfolk). Net present value for maintenance of a pier structure itself is an important cost issue but it is difficult to estimate and is usually computed as negligible because the initial major maintenance items typically do not occur until 20 years into the life of the structure.

Traditional financial analysis methodology used in Navy infrastructure project evaluation discounts even significant costs that are encountered 20 or more years in the future to result in small present values. However, a multigenerational financial point of view is appropriate for a project with a focus of achieving several decades of useful life extension. It is clear that there is significant value to future Military Construction (MILCON) budgets and military facility planners if reasonable cost pier facilities could be constructed that would remain functional two or three times longer than current Navy pier construction.

For this to be a reality, the pier configuration must be developed to allow efficient and economical updating of the utilities and systems to keep pace with the technological changes in the vessels that will make up the fleet of the future. Hence, there are two apparent focuses in this study: (1) develop more durable low-maintenance structures with an extended life, and (2) implement measures that provide reduced utilities maintenance and the ability to upgrade ship service utilities as vessel technology changes.

Utilities maintenance can be broken down into three categories: normal scheduled maintenance, repair and replacement, and emergencies. The scheduled maintenance is mandatory and all efforts should be made to both reduce the requirement for and make these tasks as easy as possible by preferential location of equipment and easy access. The highest cost items, however, are the repair and replacement and emergency functions. This is so because in most conventional Navy piers many utility runs and nonessential equipment (at least until it breaks) are in typically hard to access spaces (e.g., under the deck or in the water). A multiple-deck pier, thoughtful design, and use of noncorroding composite elements as appropriate have the potential to reduce the utilities and systems maintenance costs significantly.

The primary application of the pier concepts developed in this effort will be to replace obsolete pier facilities at existing Navy installations. The existing inventory of Navy pier facilities represents an investment of many billions of dollars made over the last 50 years. Many of these facilities have now become candidates for replacement as a result of either functional obsolescence or structural deterioration.

In many cases, the cost of upgrading utilities and ship service systems on existing piers is so high that upgrading is judged as economically not viable. NFESC has had a good history of adapting state-of-the-art advances in materials and design to produce improved facilities to support the Navy's various missions. With recent advances and material cost reductions in FRP composite technology, an opportunity exists to make significant improvements in the design and construction of a new class of Navy piers. This advancement will benefit both current operations and position the Navy for more cost-efficient operations into the 21st century.

The purpose of this report is to recommend the general configuration of the Navy pier to be addressed in this program. This program will apply FRP composite technology and develop a configuration for a pier that both allows efficient operations and provides maximum configuration flexibility relative to installed vessel support systems.

The construction process involves many stakeholders, including NFESC, Naval Stations (NAVSTA), the Fleet, Naval Facilities Engineering Command (NAVFAC), and other Navy operations groups depending on the facility. The current construction process can be and is very disruptive to adjacent naval operations. A major emphasis in this study will be toward reducing this disruption by minimizing on-site construction activities and also reducing the requirement for future maintenance operations.

### **1.3 PHASE 1 SCOPE OF WORK**

The scope of work for the Phase 1 effort included the following elements:

- Quantify pier operational requirements
- Evaluate fixed versus floating piers
- Develop 75-year zero maintenance durability criteria
- Form and periodically convene a composite advisory committee
- Develop FRP/concrete hybrid design criteria
- Quantify global and local element structural requirements
- Select element configurations and materials
- Develop and finalize overall structural configuration
- Estimate relative costs of proposed configurations

- Evaluate proposed configuration against operational criteria
- Define Phase 2 project activities
- Prepare a report of the Phase 1 activities

## SECTION 2 OBJECTIVES OF THE PHASE 1 PROGRAM

The operational objectives of this program are: (1) to take maximum advantage of Navy operational experience with berthing piers and combine the best features to provide a berthing facility that is operationally superior to current Navy berthing facilities, and (2) to take full advantage of recent advances in the use of FRP composite technology in civil construction to produce a berthing facility that has a zero maintenance life of 75 years or more.

Phase 1 of the program is to develop the basic configuration and concept that has the greatest prospect of achieving these objectives. If the results of the Phase 1 program are judged sufficiently promising, the details of the recommended berthing facility configuration will be confirmed and further developed in succeeding phases of the program.

### 2.1 OPERATIONAL OBJECTIVES

The pier should provide berthing capability for Guided Missile Cruisers (CG), Guided Missile Destroyers (DDG), and Guided Missile Fast Frigates (FFG) berthed two abreast. The facility should provide:

- Operational space
- Ship service utilities (water, electrical power, steam, sewer, compressed air, communications, fire alarm)
- Waste handling
- Support facilities
- Personnel transfer features
- Maintenance and repair capability
- Cargo transfer capability
- Access facilities
- Fendering
- Crane services
- Mooring devices
- Access to external transportation
- Lighting



- Security provisions

## **2.2 OPERATIONAL FLEXIBILITY OBJECTIVES**

It is recognized that current Navy pier facilities have limited operational flexibility and that more flexibility in terms of economically feasible adaptability to changing missions would be a significant advantage.

### **2.2.1 Modularity**

The new pier facility should incorporate modularity on several levels. Modularity at the complete facility level should be considered, as well as the possibility of partial length modules that can operate at stand-alone berthing facilities. Modularity at the system level should be considered to allow efficient installation, maintenance, and upgrade of berthing facility systems and elements.

### **2.2.2 Utility/Systems Flexibility and Update Ability**

Navy vessel technology changes at a rate far in excess of the rate of berthing facility structural obsolescence. Similarly Navy planners often redeploy vessels geographically for strategic reasons. This creates the requirement to upgrade and revise berthing facilities to accommodate the needs of fleet vessels. With current Navy facilities designs, performing major utilities upgrades are often costly to the point of fiscal impossibility. It is an objective of this program to provide the additional planning and foresight necessary to configure ship service utilities in ways that make utility upgrading a more economically viable method of accommodating changed vessel requirements.

## **2.3 TECHNOLOGY APPLICATION OBJECTIVES**

The Navy has a history of taking advantage of new technology to more efficiently perform their various missions. For a number of years, NFESC has been involved in the application of FRP composite materials to waterfront and marine facilities. This program has a technology development objective to take maximum practical advantage of the current state-of-the-art use of FRP composite materials for civil engineering facility construction.

Similarly, the appropriate use of lightweight concrete made with manufactured lightweight aggregate is an objective of the program. It is recognized that incorporation of lightweight concrete into pier facility design has the potential of significantly contributing to facility long-term durability.

## 2.4 COST OBJECTIVES

The primary focus of this program is the reduction of overall program level maintenance and operation costs associated with berthing facilities. It is recognized that facility upgrade cost to accommodate changes in berthed vessels is an important element of the overall program cost to be controlled. The fiscal reality is, however, that the first costs of new berthing facilities must be reasonably competitive with conventional construction in order to be considered for inclusion in the MILCON budget decision-making process. Thus competitive capital cost is an important element of this program.

### SECTION 3 PHASE 1 PROJECT TEAM ROLES

The team members involved in the Phase 1 work are listed below. Together the team members have expertise in all of the areas of importance to the development of the Phase 1 MHP concept.

- **BERGER/ABAM Engineers Inc.** - Provided overall project management, structural design criteria development, structural design, operational configuration, and report preparation.
- **Ben C. Gerwick Inc.** - Provided input on operational configuration, construction methods, concrete materials, and moorings, plus review and comment on the overall program effort. Also provided input to Phase 2 scope of work development.
- **University of Wyoming** - Dr. Charles Dolan provided input on the selection of appropriate FRP materials, design criteria, and performance evaluation of FRP/concrete hybrid designs. Also provided input to Phase 2 scope of work development.
- **NFESC** - Provided overall program guidance and review plus input on Navy operational requirements, input regarding program cost and maintenance requirements, experience with FRP materials, testing methods and requirements, contacts within the composites industry, and program funding.
- **ISIS Canada** - Provided gratis input on the use of diagnostic sensors in conjunction with new FRP materials to enhance structural reliability and time maintenance requirements. Also provided input to the Phase 2 planning and testing program.
- **Composites Institute** - Provided gratis information regarding FRP materials, elements, and products applicable for use in the modular hybrid pier design. Also provided review and comment on the portions of the work addressing use of FRP materials.

## **SECTION 4 EXECUTION OF THE PHASE 1 PROJECT**

### **4.1 KICKOFF MEETING**

A project kickoff meeting was held in San Francisco, California. Attending were representatives of NFESC, B.C. Gerwick Associates, BERGER/ABAM Engineers, and Dr. Charles Dolan of the University of Wyoming. Minutes of the working group meeting are included in Appendix A.

### **4.2 MISSION FOR PHASE 1 PROGRAM**

The objectives of the program are listed in Section 2. Once the fixed versus floating pier decision had been made in favor of a floating pier, the essence of these objectives can be stated as: "Find a way to construct a very functional, extremely long lasting floating pier using low-maintenance FRP materials and products in all ways that are economically feasible. This is to be done while meeting the cost target of a prototype that costs no more than 120 percent of a conventional Navy double-deck pier."

### **4.3 QUANTIFICATION OF OPERATIONAL REQUIREMENTS**

Operational requirements for this study were developed from MIL-HDBK-1025.1 and from the experience of the design team. Specific operational requirements relative to vessel support services will be further developed in Phase 2 of this work.

### **4.4 EVALUATION OF FIXED VERSUS FLOATING PIERS**

Evaluation of fixed versus floating piers was the initial task of this effort. The pros and cons of three types of pier construction were developed and used as the basis of the recommendation to develop a floating concrete pier as the recommended solution. This work is given in Section 6 of this report.

### **4.5 PRELIMINARY OPERATIONAL CONFIGURATION**

A preliminary operational configuration was developed based on a combination of input from MIL-HDBK-1025.1 and insights gained from design team member participation in a value engineering effort of the recently designed double-deck Pier 2 at NAVSTA Norfolk.

### **4.6 EVALUATION OF COMPOSITE TECHNOLOGY SUITED TO PURPOSE**

Evaluation of composite technology for this project was accomplished via input from Dr. Dolan of the University of Wyoming, conversations with vendors and material suppliers, studies

of available research papers, and personal knowledge of the design team. The main focus of effort in this phase was the determination of appropriate FRP technology to use in the FRP/concrete hybrid primary structure of the floating pier.

#### **4.6.1 Interaction with Composites Institute**

A meeting was held with representatives of the Composite Institute to explain the program and outline areas where input from their membership would be helpful to the design team. As a result of this meeting, many producers and material suppliers have provided product information to the design team for use in the development of the floating pier design. A summary of the results of this meeting is provided in Section 13 of this report.

#### **4.6.2 Development of Design Philosophy/Methodology**

After reviewing a variety of candidate approaches to using composites in the primary structure of the floating pier, it was determined that one approach was most likely to meet both the durability objectives of the project and the cost objectives of the project. This approach was to extend current state-of-the-art prestressed concrete technology to incorporate carbon fiber-reinforced plastic (CFRP) materials in place of the currently used steel reinforcing and prestressing materials and in conjunction with lightweight concrete use. The design approach developed is given in Section 7.5 of this report.

#### **4.6.3 Review of Composite Material Requirements**

Literature and material supplier input has been reviewed to define the characteristics of CFRP materials selected for use in the primary structure. Meetings have been held with CFRP mesh manufacturers to clarify the types of mesh configurations and the material properties of the mesh that can be provided in the time frame of this project.

#### **4.6.4 Review of Lightweight Concrete Requirements**

It was determined that lightweight concrete was particularly applicable to this project because this project has as one of its objectives extremely long life and very low-maintenance characteristics. Properties of lightweight concrete were reviewed in the context of the needs of this project to define the unique requirements and benefits of using this material for a floating concrete pier. The results of this work are provided in Section 8 of this report.

### **4.7 REFINEMENT OF DESIGN METHOD**

The design method given in Section 7.5 of this report has made certain assumptions about the behavior of concrete sections reinforced with CFRP mesh elements. This assumed performance must be verified by tests. It is likely that as result of the test program results, the design method proposed here would be modified to be consistent with the test results.

#### **4.8 REVIEW OF APPROPRIATE MOORING CONCEPTS**

Several possible mooring concepts were developed to determine if one concept was significantly better than the others. While the principles of mooring facilities like this are known, the configuration that best suits a particular deployment site is likely to be best determined once the details of the site are known. The mooring concept work is described in Section 11 of this report.

#### **4.9 ESTIMATION OF PRELIMINARY PROJECT COSTS**

A preliminary estimate of costs was developed. This estimate was based on historical costs for floating concrete facilities of similar cross section (floating bridges and floating commercial pier facilities). An improved method for estimation of costs that considers the development of new construction methods applicable to the FRP/concrete hybrid design will be developed as part of Phase 2.

#### **4.10 DEFINITION OF PHASE 2 SCOPE OF WORK**

With the development of the floating pier concept level configuration and the proposed method of incorporating CFRP materials and lightweight concrete to construct a CFRP/concrete hybrid structure, the necessary work to move the project forward into Phase 2 can be defined. The proposed scope of work for Phase 2 is given in Section 17 of this report.

## **SECTION 5 PREVIOUS WORK RELATED TO THIS PROJECT**

This project has taken advantage of applicable work performed by others to the maximum extent possible. A literature search has been performed to identify research applicable to this type of facility. The focus of the work has been to use existing materials and design methods where they exist. Where needed information is missing, it has either been developed (as in the case of the design methodology given in Section 7.5) or noted as something to be developed in later stages of this program.

### **5.1 PREVIOUS WORK BY NCEL (NOW NFESC) AND NAVY ON FLOATING PIERS**

In the 1980s, the Navy explored the floating pier concept in considerable depth. A design of a full-scale floating pier was commissioned in this time frame. Much of the Navy's work on floating piers was assembled into the NCEL document, Advanced Pier Concepts User's Guide UG-0007. The design team for this project took advantage of the information in this publication.

### **5.2 PREVIOUS WORK BY PROJECT TEAM MEMBERS**

Starting in the mid-1970s, BERGER/ABAM began designing large-scale floating concrete structures. Starting first with design of floating facilities for the oil industry, the company developed a design for a floating container dock now in use at the Port of Valdez, Alaska. This work and the design and construction concepts that resulted from it are directly applicable to this project.

Both BERGER/ABAM and B.C. Gerwick have been continuously involved in the design and upgrade of both commercial and Navy piers since the 1960s. This experience has provided the necessary background in pier functional requirements that support this effort.

Both BERGER/ABAM and B.C. Gerwick have been involved in projects that involve the use of high-quality marine lightweight concrete. This background is directly applicable to the needs of this project.

B.C. Gerwick and their parent company, COWI Consult, have been involved in the evaluation of various FRP materials for bridge construction.

Both the University of Wyoming and ISIS Canada have been involved in the application of FRP composites to civil engineering structures. ISIS Canada has also been involved in sensor technology used to monitor the structural integrity of civil structures via remote sensors.

### **5.3 COMPOSITES RESEARCH AND DEVELOPMENT APPLICABLE TO THIS PROJECT**

There has been and continues to be significant activity related to the use of FRP composite materials in civil engineering applications. Much of the work performed by industry has been done in Japan. In the United States, universities have done most of the research and

development work. Several large-scale prototype structures have been built using FRP composite materials in different ways.

### **5.3.1 NFESC Work**

NFESC has been involved in the application of FRP materials to waterfront construction and repair since the early 1990s. Much of the NFESC work has been published and has been made available to this design team in two compendium publications, SP-2017-SHR and SP-2018-SHR.

### **5.3.2 University of Wyoming Work**

Dr. Dolan of the University of Wyoming has been working in the field of FRP composite application to civil engineering structures for the last nine years. Dr. Dolan also has many years of structural engineering design consulting experience. His unique background as both a researcher in FRP materials and a designer has been very useful to the team in efforts to determine those aspects of FRP/civil engineering that are mature enough to use in a design development project with a near-term construction schedule objective.



## SECTION 6 EVALUATION OF FIXED VERSUS FLOATING PIERS

### 6.1 STRUCTURAL CONCEPT 1: BASELINE STRUCTURE – CONVENTIONAL PILE-SUPPORTED DOUBLE-DECK NAVY PIER

#### 6.1.1 Description

The baseline pier concept for all comparisons represents the current state-of-the-art design for berthing piers within the U.S. Navy. This concept is illustrated in Drawing S-1 (at the end of the report in Drawings). The key benefits of this type of pier include the following:

- “Clear” working deck (upper deck)
- Utilities are located in the interstitial space between the lower and upper deck

#### 6.1.2 Construction

The construction process usually begins with site preparation, including demolishing existing structures, dredging and reclamation, uplands construction, and utility construction. This work can take from several months to several years depending on many factors, including the extent of environmental remediation necessary. Conventional Navy pier construction is typically performed with waterborne equipment. This type of pier construction is characterized by numerous pilings closely spaced. Pile driving for a typical pier can take from six to nine months once site preparation is complete. Piles are driven, the deck system is constructed, and the fender system and utilities are installed. Deck systems are varied and can consist of pile caps supporting precast deck panels, cast-in-place flat soffit deck, etc. Single-level finger piers 1,200 to 1,400 feet (366 to 427 m) long by 120 feet (36.6 m) wide can typically be built in 18 to 24 months after the site has been prepared.

#### 6.1.3 Costs

Costs for this type of structure can vary significantly depending on geographical location and site conditions. Single-deck commercial piers as described above, but with limited utilities, can be constructed for approximately \$80 to \$100 per square foot of working deck area (not including the area of the utility decks) (\$860 to \$1,075 per square meter). Navy piers are typically more complex because their mission usually involves more than simple berthing. The berthing functions at Navy piers are also significantly different from commercial piers; one of the primary functions is to provide electrical power to the ships on berth. Other operations include refitting and crew training. Therefore, the types of utilities and other features required are more sophisticated. The fendering systems are also more sophisticated. A double-deck pier of the above plan geometry can be constructed for \$140 to \$160 per square foot (\$1,505 to \$1,720 per square meter) of working deck area, over a time period of 24 to 30 months. The cost is slightly higher than the comparison of Navy pier construction costs as quoted above. This is because the pier deck loading criteria defined for this project is greater for this baseline design than for the projects available for comparison.

#### 6.1.4 Characteristics and Possibilities

The conventional pile-supported pier has the following characteristics:

- Requires the longest time of on-site construction activity – maximizing the period of construction disruption.
- Has maximum susceptibility to regulatory construction schedule disruption (e.g., fish windows for in-water construction) of any concept – maximizing the schedule uncertainty and constraints resulting from regulatory requirements.
- Has the greatest amount of more costly overwater construction activity – resulting in higher unit costs when compared to facilities that can be prefabricated in the dry or on land.
- Requires more costly on-site utility and support system installation – minimizing the opportunity to benefit from the economies of “factory installed” utility systems.
- Requires success with field quality control efforts – actually achieved project as-built quality is an important determinant in long-term maintenance requirements – placing critical reliance on the success of an activity that traditionally has problems and is heavily construction contractor dependent.
- Contains the cost of two full decks (lower utility deck is typically not efficiently used) – concept with same function but less utility deck space may be more economical.
- Is sensitive to tidal range in both design and operations – requires site-specific fendering, site-specific pier-to-ship utility connection strategies, and site-specific piling design to achieve proper operations throughout full tidal range.
- All piling groups must be designed to carry full concentrated and full uniform load, even though this load will not be on all pile groups at the same time – increasing the cost of this important element of the design criteria.
- Design is very site specific: sensitive to local soils, sensitive to local bathymetry, sensitive to local seismic conditions – resulting in designs that are very difficult to compare in terms of cost and very difficult to standardize or optimize (one size does not fit all).

The primary advantages of this type of conventional construction are:

- Cost of construction is well known
- The type of construction involved is well understood by many marine contractors
- The construction risks are primarily related to uncertainties in subsurface conditions

The possibilities for improvement are only incremental with this type of construction. Each project of this type will always be a primarily site-specific project because of the importance of site conditions on the design of the facility. Piers sited at locations with poor foundation conditions and/or high seismicity will be more costly than facilities sited in more favorable conditions. Piling layouts and the associated piling costs (typically 30 to 40 percent of the total pier cost) will be more or less efficient depending on the skill and design philosophy of the design team selected for each facility.

## **6.2 STRUCTURAL CONCEPT 2: OFF-SITE PREFABRICATED FLOAT-IN, PILE-SUPPORTED MODULAR PIER**

### **6.2.1 Description**

This concept is illustrated in Figures 6-1 and 6-2. The premise is to build as much of the structure off site as possible then float it on barges to the site in large modules and erect the structure on to a system of large diameter piles. The concept involves 20 to 25 modules, 60 to 120 feet (18 to 37 m) long. This concept is very similar to that employed for the construction of the Prince Edward Island to New Brunswick bridge crossing in Canada (see Appendix B for a description of this project).

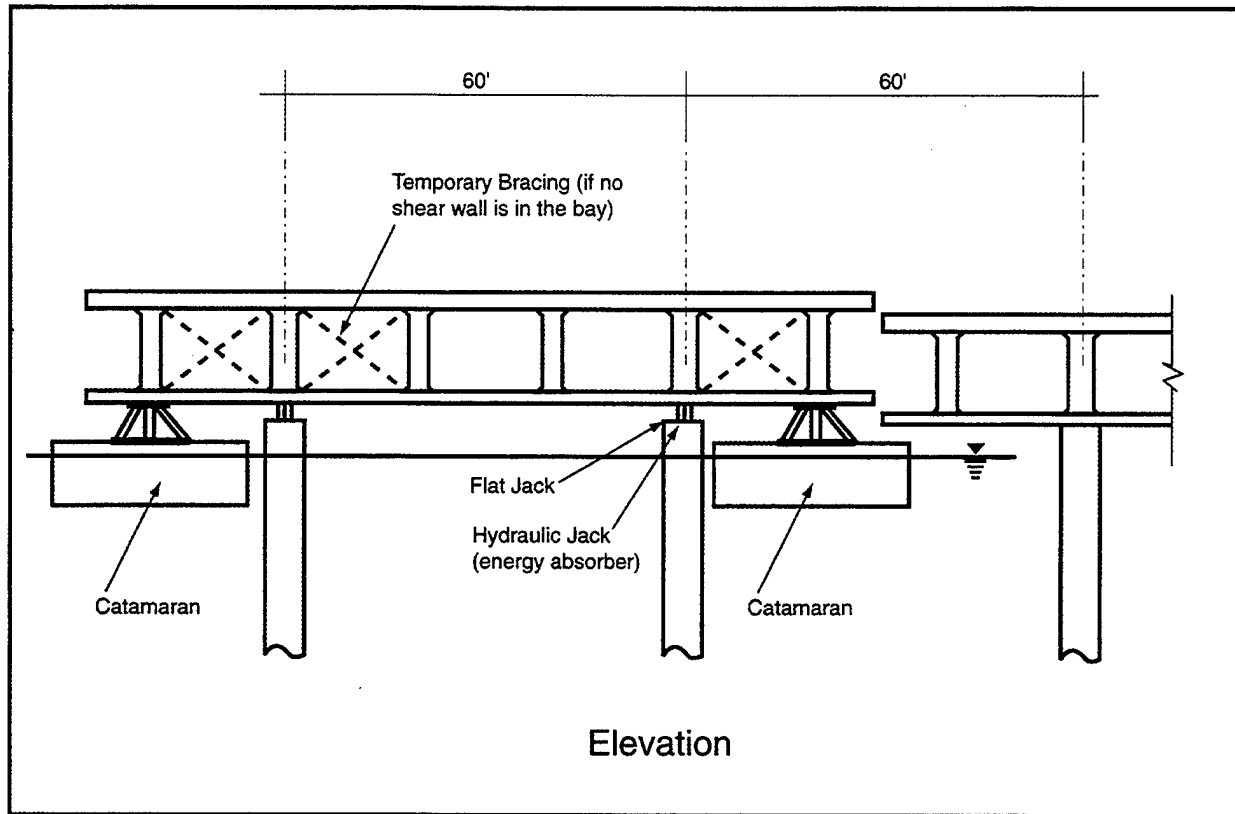
The float-over method has been frequently used in offshore industry for mating the off-site prefabricated top sides and gravity base structure (GBS) that supports the topsides above the sea floor. Recently, the technique has been successfully used for mating in the open sea with significant sway and heave. With this method, each double-deck unit can be precast segmentally on pillars. Segmental casting on pillars has been successfully used in precasting bridge deck units for the Prince Edward Island bridge and the Great Belt Link bridges between Copenhagen and the mainland in Denmark.

The goal of this concept is to reduce the amount and duration of on-site construction. It should also be stressed that off-site fabrication under controlled conditions will lead to better quality control, with resultant improvements in quality-related maintenance requirements.

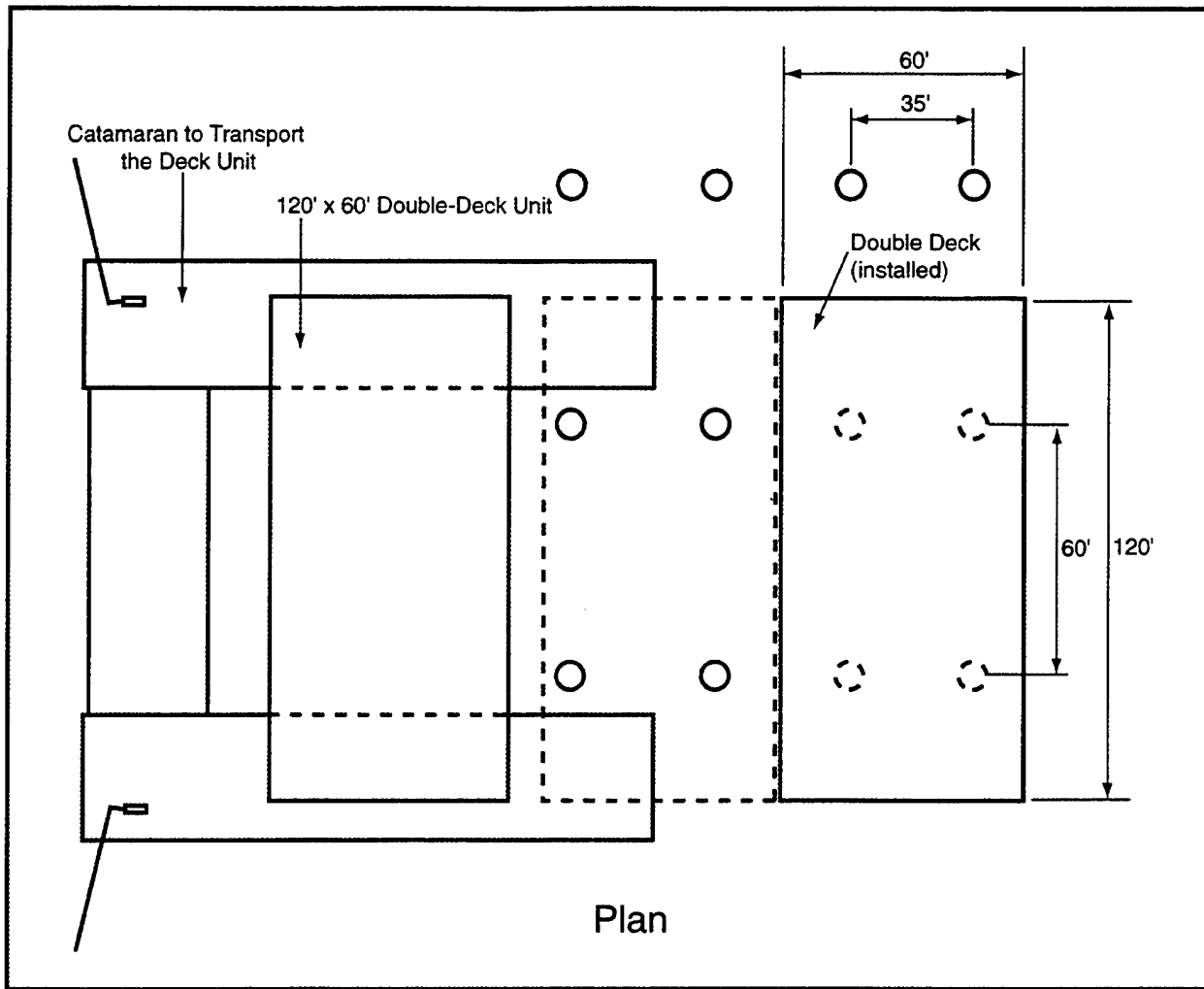
### **6.2.2 Construction**

Off-site construction would occur at a water accessible construction site. The general concept is to prefabricate modules and integrate them into larger units. The size of the large units will be dictated by design (available pile capacity) and construction equipment limitations. The large units are stored at the off-site construction location until needed. These large units are then loaded onto barges for transport to the site and erection.

Site preparation is similar to structural Concept 1. Structural configuration is similar to Concept 1 except that fewer and larger diameter pilings would be installed. The goal is to reduce work in the field. Construction of this concept begins with development of a fabrication and storage yard. This work typically precedes pier site preparation.



**Figure 6-1**  
**Off-Site Prefabricated Float-In, Pile-Supported Modular Pier – Sheet 1**



**Figure 6-2**  
**Off-Site Prefabricated Float-In, Pile-Supported Modular Pier – Sheet 2**

**Note:** A double-deck unit is floated over the previously driven piles using a catamaran construction transporter.

Precasting and storage of completed segments and field installation of piling and pile caps proceeds simultaneously. Installation of the prefabricated units is as follows:

1. A completed 60-foot (18.2-m) wide precast double-deck unit is transported to the site by a catamaran/barge. The unit on the catamaran/barge floats over the driven piles. It is assumed that each span will be constructed of two 60-foot (18.2-m) wide units.
2. Hydraulic jacks that are preinstalled on the pile heads extend to engage the precast unit.
3. The catamaran/barge is ballasted down and towed away.
4. The hydraulic jacks are retracted lowering the precast unit onto flat jacks that are used to level the unit.
5. The hydraulic jacks are removed.
6. A "pinned" connection is made at each pile cap to precast unit connection.
7. Closure pours are made at longitudinal and transverse joints between precast units.
8. The precast units are post-tensioned together transversely and longitudinally.

### **6.2.3 Costs**

Costs for this type of construction are anticipated to be higher than those for the baseline structure. This is because of the need to develop and construct specialty equipment for use in the project. Past experience has shown that large diameter piles are less efficient than small diameter piles, in terms of cost per ton of supported vertical load. But, large diameter piles can resist lateral loads without additional bracing or batter piles.

An estimated cost range for this type of construction is \$150 to \$175 per square foot (\$1,615 to \$1,885 per square meter) of working deck area. The benefits of this type of system are that it is somewhat similar to conventional pier and bridge construction and there is a potential for reduced on-site construction time and, hence, a reduction in disruption to existing naval operations.

### **6.2.4 Characteristics and Possibilities**

The off-site prefabricated float-in, pile-supported modular pier has the following characteristics:

- Requires less time than the baseline for on-site construction – fewer large diameter piles could be driven in a shorter time than the baseline pile driving, and deck elements can be erected faster, thus reducing on-site construction time.

- Requires less in-water construction than baseline design – thus less potential regulatory schedule constraints.
- Involves significant overwater construction involving large marine equipment for driving large diameter piles and installing long-span pier elements – costs of mobilizing marine equipment and the large scale marine operations may be a significant portion of the facility construction cost.
- Provides increased opportunity for off-site prefabrication compared to the baseline design – provides the prospect of improved quality and economy of construction in the dry.
- Provides increased opportunity for off-site utility installation – trade-off to be studied because of the cost of providing utility joints at module ends (approximately every 60 feet [18.2 m]).
- Contains the cost of two full decks plus the cost of long-span structure span capability and greater costs for the large diameter piling.
- Fendering system may be more costly than baseline because of the longer spans involved combined with the requirement to deal with the full tidal range.
- Design is possibly more sensitive to local soil conditions and seismicity – fewer higher capacity piles will be used, resulting in higher loads being transferred to fewer elements with resultant concerns regarding reduced redundancy and consequences of pile damage or settlement.
- Costs are likely higher than the baseline costs – structure cost will likely be similar to long-span segmental bridge structure construction – cost reduction potential is incremental from bridge construction costs.
- Long-span deck structure will require significant amounts of FRP prestressing and FRP shear reinforcing – this is likely a more critical reliance on the new FRP materials and will represent an increased project risk.

The possibility of this approach is to off-site prefabricate modular units as large as can be practically handled in the marine erection activity. The objective would be to systematize the off-site construction of the deck modules in the dry, and move them onto a submersible or crane barge for delivery and installation. The units would be moved into position and lowered or lifted onto the large diameter piling system. Key to this approach would be the development of economical marine operations to handle the large modules.

### **6.3 STRUCTURAL CONCEPT 3: OFF-SITE PREFABRICATED, PERMANENTLY FLOATING DOUBLE-DECKED PIER**

#### **6.3.1 Description**

This concept consists of a permanently floating highly compartmentalized concrete structure (see Drawing S-2 at the end of the report in Drawings). This concept causes the least disruption to ongoing naval operations at the site of the new construction and with adjacent activities. The structure is completed and outfitted off site and towed to the final deployment site. The only remaining deployment site operations are connections to the land-based utilities and to the preinstalled mooring system(s) and some equipment checkout. Other benefits to this type of structure are the ability to use below deck space (hull compartments) to accommodate operations activities, and the ability to remove and relocate the structure if required.

Floating structures have been successfully used in areas where normal marine construction cannot be economically conducted due to lack of equipment, remoteness, etc., or unfavorable cost factors. They have also been used where minimizing the on-site construction disruption is important. Floating structures also lend themselves nicely to areas with high tidal ranges so that relative heights/distances between ship decks and the pier working surface remain constant.

#### **6.3.2 Construction**

The structure would be constructed off site in a developed and controlled factory environment and towed to the final deployment site either in large modular units 250 to 500 feet (76 to 152 m) long or as a single full-length unit. Site preparation is similar to that required for structural Concept 1. The on-site waterborne equipment work is limited to installation of the mooring system(s) and tug positioning assistance during floating structure installation.

#### **6.3.3 Costs**

Costs for this type of construction are on the order of \$200 to \$220 per square foot (\$2,150 to \$2,365 per square meter) of working deck space. The cost is dependent on the availability of construction facilities (dry docks, graving docks, or launch facilities), length of tow to final deployment site, integration methods, and mooring configuration. The floating pier can be built off site in 18 to 24 months. Integration of hull sections to form the full-length pier can take another one to two months. Integration activities should be performed near the project site but do not have to be at the final deployment site. Final installation can take another two months. This work includes mooring the structure to the preinstalled mooring points, attaching shore access ramps, and connecting utilities and associated systems to shore and systems checkout.

#### **6.3.4 Characteristics and Possibilities**

The off-site prefabricated, permanently floating pier has the following characteristics:

- High level of watertight compartmentalization provides safety against sinking, even in the event of compartment breach by damage.



- Requires least time for on-site-construction – This concept provides the opportunity to achieve near zero site construction disruption.
- Least amount of in-water construction activity – Will provide wider latitude in dealing with regulatory requirements related to in-water construction.
- Requires least amount of overwater construction activity – Provides the prospect of economy related to construction in the dry for much of the facility.
- Requires the least amount of marine construction equipment to support the installation – This avoids high equipment mobilization and operational costs associated with this type of equipment.
- Full off-site utility and systems installation and checkout is possible – This leads to both cost savings and quality improvement due to more controlled working conditions for this work.
- Can be optimally configured to allow efficient operations with less than two full decks – Partial-width utility decks no wider than needed for functional reasons can easily be accommodated by this concept.
- Is not sensitive to changes in tidal range or to daily tidal cycles – Facility rises and falls with the ship as the tide level changes.
- Is not sensitive to local soils conditions or local seismicity – Design can be almost completely independent of local soil and seismic conditions. Little premium is paid for facilities constructed in locations of poor soil or high seismicity.
- Provides the opportunity for capital cost savings and maintenance reduction in the fender system – Relationship of fender system and vessel remains constant at all tidal levels reducing the required vertical area to be fendered and minimizing the abrading action of the vessel moving vertically against the fenders.
- Enclosed below deck space is available for a variety of uses – Space is provided free by this concept. With minimal cost, space can be conditioned for a variety of uses that add value to the facility (selected crew amenities and on-shore activities could be accommodated within the pier facility).
- Use of FRP reinforcing grids and lightweight concrete make substantial material quantity savings possible, when compared against previous state-of-the-art floating pier designs. There is a significant potential for the development of a breakthrough in panel design to resist hydrostatic forces using FRP/concrete composite elements – This has the potential of providing both economy and very long-term durability.

- Hinged ramp to shore is required to accommodate tidal range – This element would be slightly more costly than a conventional access trestle.
- Cost of graving dock rental or construction may add to total project cost – Navy would benefit from investigation into providing a surplus graving dock or dry dock facility as Government-Furnished Equipment to reduce overall costs.
- Buoyant structure below operating deck does not need to be designed for full concentrated load and full uniform load everywhere at the same time as does a conventional pile-supported pier – This offers the prospect of substructure cost savings.

The permanently floating pier concept would be prefabricated in long modules, 300 to 500 feet (91.5 to 152.5 m) in length. These units would be moved to the site either as a “wet tow” or on submersible barges depending on the tow distance. The units would be joined into a full-length pier at a staging area near the final deployment site and moved into position as a unit. The facility would either be moored using a taut line system with anchor boxes or anchor piles on the sea floor or by using fixed guide piles or mooring dolphins. Utilities and systems would require only hookup-to-shore utilities and the facility would be ready for operation.

#### 6.4 RECOMMENDED STRUCTURAL CONCEPT

It is recommended that this project move forward with the development of a permanently floating pier with utility galleries on either side of the pier below the working deck, as shown in Drawing S-1 (at the end of the report in Drawings).

The cost of a permanently floating facility like this is on the order of \$200 to \$220 per square foot (\$2,150 to \$2,365 per square meter) of working deck space. This value is based on current pricing assuming a one-of-a-kind project using construction technology similar to that used to construct modern floating bridges.

Assuming that 35 percent of the cost of a Navy pier project is due to the bare structure cost of the pier, the Concept 1 baseline conventional pier overall project cost would be \$140 per square foot (\$1,505 per square meter) divided by 0.35 equals \$400 per square foot (\$4,300 per square meter) of working deck space.

For a permanently floating facility, this same approach would result in a bare structure cost of \$200 per square foot (\$2,150 per square meter). If everything else remains equal, then the cost becomes  $\$400 + (200 - 140) = \$460$  per square foot (\$4,950 per square meter) of working deck space. The cost of the floating facility divided by the cost of the conventional pile-supported pier ( $\$460/\$400$ ) equals 115 percent of the cost of the baseline conventional pier. Thus, at this preliminary stage, it appears that a floating facility has the potential of meeting the objective of being within the guideline of 120 percent of conventional for the initial project.

The cost of Concept 2 (off-site prefabricated float-in, pile-supported modular pier solution) is estimated to be between the cost of the conventional pile-supported configuration and the permanently floating configuration. The potential cost and operational benefits of this approach and the potential increased value of this concept are not judged to be equal to those of the floating facility.

The actual impact on construction cost of using FRP materials and FRP/concrete hybrid designs is difficult to estimate at this point. This is because large-scale designs using FRP/concrete hybrids have not yet been accomplished and costs for the FRP elements that will be used in the pier construction have not been determined on a production basis.

It is judged, however, that the permanently floating facility offers the greatest prospect of reduced construction costs from the baseline of \$200 to \$220 per square foot (\$2,150 to \$2,365 per square meter) of working deck area. This concept also offers the greatest number of previously listed potential benefits in terms of features, such as less construction disruption and greater opportunity for standardization. When costs are assigned to the additional benefits listed in Section 6.3.4, Characteristics and Possibilities, it is believed that the permanently floating double-deck pier facility is the most likely of the three concepts considered to offer the clear cost and operational advantages to the Navy that warrant further development of this concept.

The possibility of a non site-specific "standardized" design provides the opportunity of repetition in construction from one project to the next to an extent not possible with any of the other concepts. This fact offers the potential for standardization of utility and subsystem designs that are then exactly the same for each installation, and fender system standardization that is exactly the same from installation to installation. In addition to potential substantial cost savings, this standardization should pay benefits in maintenance, training, and operational optimization over time.

## SECTION 7 DESIGN APPROACH

### 7.1 DESIGN CRITERIA

Design criteria for Navy piers are presented in MIL-HDBK-1025/1 (Ref 1). The MIL-HDBK provides the loads and load combinations for design of typical pier structures, however, two unique structures are being evaluated here that are not adequately covered; long-span, pile-supported piers and floating structures. This section will discuss specific design criterion as it affects this study and is not intended to be complete in itself.

#### 7.1.1 Water Depth

Water depth at berth: 40 feet (12.2 m)

Drafts of current Navy surface combatants range from 26 to 33 feet (7.9 to 10 m).

Tidal range: 6 feet (1.8 m)

(The Phase 2 effort will include a review of the tidal ranges at all locations that are candidates for the installation of the new piers.)

#### 7.1.2 Structure Length

The structure's length should be capable of berthing four ships, two per side. The length of the structure "...should equal the total overall length of the largest ships simultaneously accommodated, plus clear distance allowances of 100 feet between ships and fifty feet beyond outermost moored ships." (MIL-HDBK-1025/1). Assuming medium surface combatants with an LOA of 600 feet (183 m), this results in a nominal structure length of

$$L = 50 + 600 + 100 + 600 + 50 = 1,400 \text{ feet (427 m)}$$

Future phases of this effort will consider NFESC comments that a 1,500-foot (457-m) length may be desirable.

#### 7.1.3 Structure Width

The nominal width of the proposed floating structure is 94 feet (28.6 m) for the hull. The working/main deck is 86 feet (26.2 m) wide between curbs. The working/main deck dimensions are based mostly on work compiled in User's Guide UG-0007: Advanced Pier Concepts, prepared by NCEL, dated October 1985 (Ref 2). The required width of the double-deck pier is controlled by the area requirements for Phased Maintenance Activities (PMA). These activities typically fall into four categories (listed in order of increasing deck space requirements):

- Intermediate Maintenance Availability (IMAV)
- Planned Restricted Availability (PRV)
- Selected Repair Activity (SRA)
- Restricted Overhaul (ROH)

The study determined that a 94-foot (28.6-m) wide main deck (width between curbs) was required. This includes a 35-foot (10.6-m) wide corridor for work areas next to each face and a 24-foot (7.3-m) wide corridor for fire lanes (two lanes x 12 feet [3.6 m] wide). The maximum workspace is required for ROH activities. The width of the work area (and corridor) was determined by crane operations, which is assumed to require a 35-foot (10.6-m) wide zone. The gross work area required would be 35 feet (10.6 m) by 429 feet (131 m) or approximately 15,000 ft<sup>2</sup> (1,395 m<sup>2</sup>) on either side of the working/main deck with an additional 8,000 ft<sup>2</sup> (745 m<sup>2</sup>) of space required on the lower deck. The berth is nominally 600 feet (183 m) long.

The same study determined that a 90-foot (27.4-m) wide main deck (width between curbs) consisting of 30-foot (9.1-m) wide corridors next to each face and a 30-foot (9.1-m) wide fire lane (two lanes x 15 feet [4.6 m] wide) was adequate for normal operations. This difference in pier width is equal to approximately 4 feet x 1,400 feet x \$200 per square foot = \$1.1 million.

The narrower 90-foot (27.4-m) wide main deck is proposed in this study based on the following discussion. Minimum pier widths for commercial piers (between curbs) are sometimes set by the minimum turning diameter (outside) of a standard AASHTO truck with a standard trailer (designation: WB-40) that is approximately 82.5 feet (25.1 m) ("A Policy on Geometric Design of Highways and Streets," AASHTO - Ref 3). Assuming normal 12-foot (3.7-m) wide traffic lanes and 30-foot (9.1-m) wide working corridors, the minimum main deck width (between curbs) for normal operations would be  $(30 + 12) \times 2 = 84$  feet (25.6 m), which is very similar to the minimum truck turning radius.

For planning purposes, assume the curbs to be 2 feet (0.6 m) wide. Then the minimum main deck width would be  $(2 + 30 + 12) \times 2 = 88$  feet (26.8 m). In addition, lighting, whether for security or work area illumination, is probably required, as are "storm" bollards. It is convenient to place these items down the centerline of the pier so that they do not interfere with work areas. Hence, an overall main deck width of 90 feet (27.4 m) (out-to-out of curbs) was chosen to provide some conservatism. The hull is 4 feet (1.2 m) wider (94 feet [28.6 m] total) to accommodate "windows" for utilities access to lower deck spaces when a ship is along side the pier.

It is unlikely that two opposing berths on either side of the pier and even less likely that all four berths will be involved in ROH activities simultaneously. Hence, it is felt that crane operations can be accommodated while still providing adequate space for fire truck access. Preliminary calculations show a heel (roll) of the structure, when one crane is picking maximum loads, of 3-1/2 inches (13 mm) (0.17 degree) across the width of the pier. These values are well within usual recommended limits of 3 degrees maximum out of levelness for cranes operating on barges. Structure out of trim due to unequal load distribution also needs to be taken into consideration. On heavy lift vessels, active ballasting systems are often used to trim the vessel during lifting. It is our sense that this will not be required for the floating dock.

### 7.1.4 Design Freeboard

Freeboard to main deck:	17 feet (5.2 m)(maximum) *
Freeboard to lower deck:	3 feet (0.91 m)(minimum)
Live load sinkage (uniform):	3 feet (0.91 m)(maximum)

\* The relative tide ranges and recommended deck heights and clearances for a double-deck pier have not been standardized in Navy design publications. It is apparent that a pile-supported, double-deck pier concept is most suitable for low tidal ranges (less than 6 feet; 1.8 m). Based on a review of other projects, a height of 11 to 12 feet (3.3 to 3.7 m) from top of lower deck to top of upper deck seems to provide reasonable access space and room for utilities.

## 7.2 DESIGN LOADS

The purpose of the design load criteria is to assure an adequate strength load path to the foundation. In a typical pile-supported pier with short spans and many piles, the vertical loads are transmitted through the deck system to the pile caps, and from there to the piles, then to the bearing strata in end bearing or friction. The uniform load would control the selection of piles and may control the design of the deck structure. The concentrated load criteria will control the thickness of the deck structure.

A floating structure is designed to support all vertical loads by buoyancy. The vertical loads are transmitted through the deck system in the transverse (lateral) direction to the longitudinal and transverse bulkheads, and then to the hull plating, which resists the uniform upward hydrostatic pressure.

Dead Loads [structure weights + utilities (wet) and other fittings]

### 7.2.1 Operational Loads

Vertical Live Loads (not a complete list)

Concentrated outrigger load	250 kips*	(1,110 kN)
Uniform live load (1)	1,200 psf **	(57.4 kPa)
Uniform live load (2)	150 psf ***	(7.2 kPa)

Hydrostatic Loads (not a complete list)      See Figure 7-1

Density of seawater	64 pcf	(1.025 t/va <sup>3</sup> )
Equal height of seawater		
Keel slab	20 feet (serviceability check)	(6.1 m)
	28 feet (ultimate strength)	(8.5 m)

Exterior walls and watertight bulkheads	17 feet (serviceability check)	(5.2 m)
	28 feet (ultimate strength)	(8.5 m)

\* The top-most deck of the pier is designed for the heaviest loads, 1,200 psf (57.4 kPa) uniform loads and crane outrigger concentrated loads. Dedicated locations for the large concentrated load should be considered so as to economize on deck design. Note that Naval Facilities Engineering Command, Atlantic Division (LANTDIV) specified dedicated heavy lift areas (250 kip [1,112 kN] outrigger loads) on their latest Norfolk pier project; all other areas were designed for an outrigger load of 150 kips (667 kN).

\*\* The uniform live load (1) is used for local strength design of main deck elements and structural support components. This load shall be limited to an area of 2,000 square feet (186m<sup>2</sup>) for global design of the hull (total load = 2,400 kips [10,676 kN]). This load can be subdivided and placed anywhere on the main deck to produce maximum bending moments and shears in the deck and hull. Note that a 600-psf (28.7-kPa) uniform design load was used on LANTDIV's latest double-deck pier design.

For a floating structure, if the uniform load of 1,200 psf (57.4 kPa) is applied to the entire deck area, it would amount to 76,000 tons (676 MN) and result in a sinkage (increase in draft) of approximately

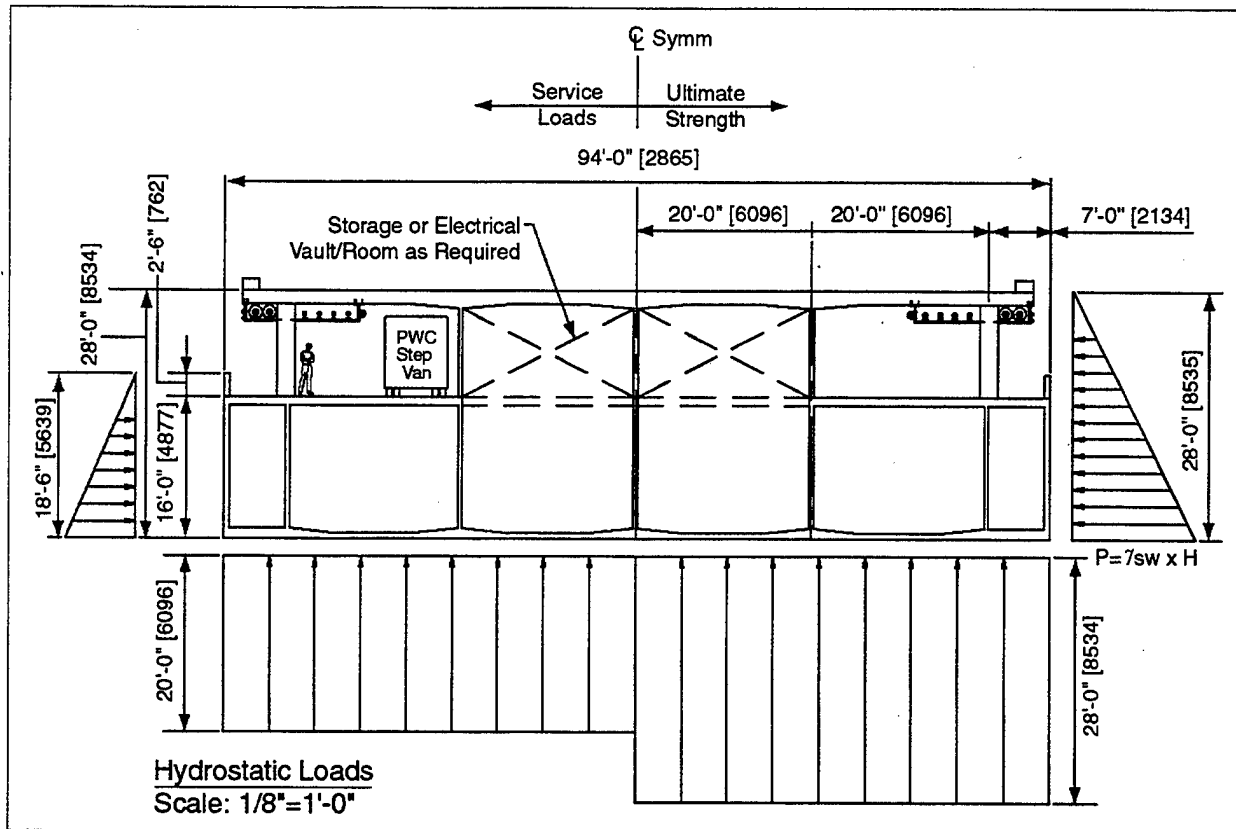
$$\Delta_{\text{draft}} = 1,200 \text{ psf} / 64 \text{ pcf} = 18.75 \text{ feet (5.7 m)}$$

This would be an unreasonable penalty for a floating structure and is not consistent with the operational use of the facility.

\*\*\* The uniform live load (2) is placed over the entire area of the working/main deck, between curbs (total load = 18,100 kips [80.4 MN]). For design, the deck is loaded in various arrangements to produce maximum hog and sag moments, trim, heel, and sinkage. This load is also used for local strength design of the lower deck elements and structural support components. This load shall be limited to an area of 8,000 square feet (745 square m) for global design of the hull (total load = 1,200 kips [5,338 kN]) when placed on the lower deck. This load is eccentric with respect to the hull centerline when placed on the lower deck and can produce a heel of approximately 8 inches (2 cm) if only one side is loaded.

## 7.2.2 Load Effects on Floating Piers

Floating structures are normally designed for two classes of live load, local loads, and global loads. The large uniform loads and concentrated loads would control the design of the transverse deck system (local loads). The longitudinal members (hull) are usually designed for smaller global uniform loads in combination with concentrated loads, and other performance criteria, e.g., maximum deflection and wave loading. It is not practical to statistically define the global load criteria (e.g., wave loading effects) in this study, however, a suggestion follows. Loading criteria consistent with the full range of operational use will be confirmed as part of the Phase 2 activities.



**Figure 7-1**  
**Hydrostatic Loads**



### 7.2.2.1 Global Load Effects

- Uniform load = 150 psf (7.2 kPa) over entire working/main deck area
- Define total area and load for large uniform load 40 by 50 feet (12.2 by 15.2 m), e.g., 40 x 50 x 1,200 ksf = 2400 kips (10,680 kN)
- Define total weight of loaded 140-ton (1,245-kN) truck crane, maximum outrigger load = 250,000 pounds (1,110 kN), e.g., weight of crane, 169 kips + lifted loaded, 280 kips = 449 kips (2,000 kN)
- Define heaviest combination of equipment load(s) to be set on deck at one time

### 7.2.2.2 Local Load Effects

- 1,200-psf (57.4-kPa) uniform load
- 250-kip (1,110-kN) outrigger load distributed over a 2-foot 6-inch by 2-foot 6-inch (0.76-m by 0.76-m) square pad

The uniform load of 150 psf (7.2 kPa) when applied to the entire working/main deck area (out-to-out) would amount to 18,900 kips and result in a sinkage (increase in draft) of approximately

$$\Delta_{\text{draft}} = (150/64 \text{ pcf}) \times (90 \text{ ft}/94 \text{ ft}) = 2.25 \text{ feet (0.69 m)}$$

A live load draft allowance of 3 feet (0.91 m) is proposed (difference between light ship and fully loaded draft). The dock utility deck level will have an operational freeboard of another 3 feet (0.91 m) above the fully loaded draft. Actual freeboard could be measured to the top of the working/main deck. The minimum freeboard to the lower deck under static load conditions will be 3 feet (0.91 m). A wave wall is provided at the outboard edge of the utility deck to add 2 feet 6 inches (0.76 m) to the static freeboard.

The recommended global loading of 150 psf (7.2 kPa) is consistent with Uniform Building Code (UBC) requirements (Ref 4) for armories and similar type heavily loaded structures.

## 7.3 GENERAL STRUCTURAL DESIGN

### 7.3.1 Concrete Design

Use ACI 318, "Appendix B – Unified Design Provisions for Reinforced and Prestressed Concrete Flexural and Compression Members" (Ref 5) approach. This is particularly appropriate when designing with composite materials that do not have a traditionally defined yield point. In this document, reinforcement limits and capacity reduction factors are based on strain rather than yielding.

A mathematical model for the design of plating elements is described in Section 7.5. Principles of design are based on the above-referenced document and the relationship shown in the stress diagram given in Figure 7-2. This model will be verified in Phase 2 of the program as testing results become available.

### **7.3.2 Crack Width Design Philosophy**

**7.3.2.1 General.** The floating structure must be designed for two types of flexure: global bending and local bending. Global bending refers to the structure's cross section behaving as a box beam in the long (longitudinal) direction. Local bending refers to flexure in the transverse direction in the individual plating elements, which comprise the box.

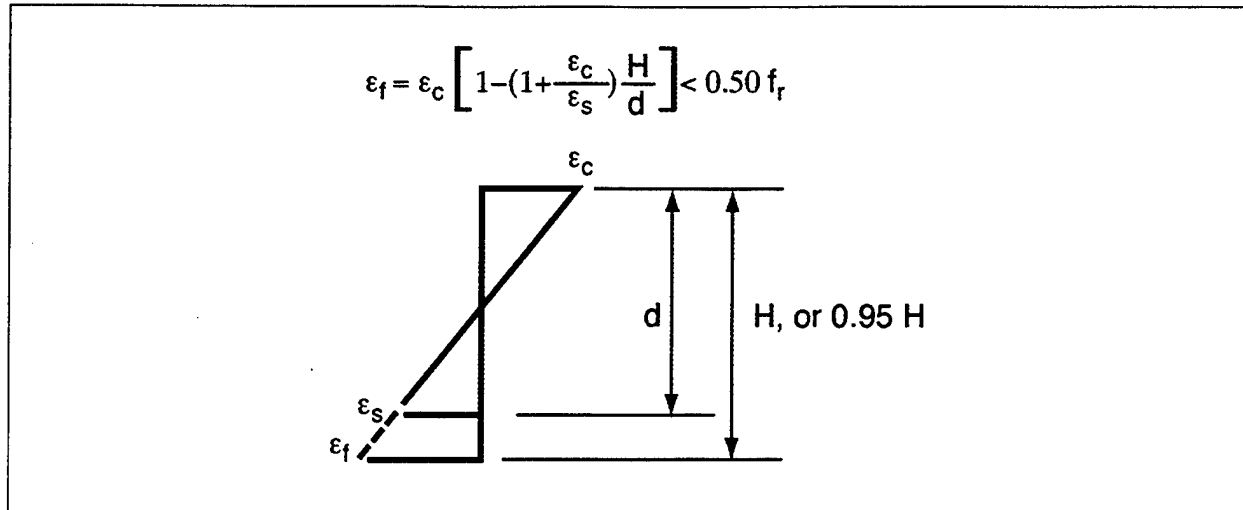
Concrete section crack width is typically measured at the surface of a concrete member. The primary reasons for limiting crack width are to provide watertightness, prevent corrosion of the steel reinforcement, and prevent unsightly cracks. Concrete will crack when the tensile capacity of the concrete is exceeded. The goal of design is to assure that the resulting concrete cracks are fine and uniformly spaced. Crack widths should be limited to 0.010 inch (0.25 mm) or less.

**7.3.2.2 Global Bending.** Global bending can result in cracking of the thin hull plating. This is not desirable because it could lead to leakage and loss of buoyancy. For this reason, the global structure is designed for zero membrane tension under service loads. Prestressing is required to provide adequate pre-compression in the longitudinal direction so that the structure is not under tension due to global bending. Because we are proposing a zero membrane tension design criteria for global bending, the remainder of the discussion will be related to local bending and flexural cracking.

**7.3.2.3 Local Bending.** Local bending can produce flexural cracks in individual plating elements. Flexural cracking may be permitted but crack widths should be limited. However, the plate elements are also prestressed in the transverse direction. The prestressing need not be designed for zero tension in this direction, which then results in a partially prestressed section under service load.

**7.3.2.4 Crack Width Design Parameters.** In steel reinforced concrete structures, the cracking pattern is controlled by spacing of the reinforcement, stress in the reinforcement, and concrete cover. The maximum tensile stress in the tension steel is limited to  $0.60 \cdot f_y$ , or so, which results in  $\sim 0.0012$  strain at the level of the reinforcement. The strain at the surface of the concrete would be greater. If other parameters are held constant, increasing the cover to the reinforcing steel will increase the design crack width. If the tension steel yields, the crack widths will become much larger.

The carbon fiber reinforcement is not subject to corrosion in seawater and hence can be placed much closer to the concrete surface. This would also suggest that a higher strain can be permitted in the CFRP, yet still provide similar crack width results.



**Figure 7-2  
Stress Diagram**

Notes:

Carbon fiber reinforcement has a modulus of elasticity equivalent to steel, an ultimate stress significantly greater than steel, and a stress strain curve that is linear to failure.

Cracking behavior and crack widths as a function of the type of reinforcement should be investigated in laboratory testing. Initially it is proposed to use a mesh-type CFRP material in an attempt to uniformly distribute the tensile reinforcement and reduce crack widths and spacing.

Durability issues, such as crack growth due to fluctuating loads and creep, should also be investigated.

## 7.4 MATERIAL PROPERTIES

### 7.4.1 Prestressing Tendon Properties

**7.4.1.1 Encapsulated High-Strength Steel Tendon Properties.** At present, encapsulated steel prestressing tendon systems are proposed for use in the design. Strand properties are to be per ASTM A 416 (Ref 6), stress-relieved, low-relaxation,  $f_{pu} = 270$  ksi (1,860 MPa). Tendons of this type are encapsulated in a protective system that includes a double layer of electrically insulating corrosion preventative material. The tendon encapsulating measures provide very high reliability in terms of corrosion prevention from both corrosive agents and electrolytic corrosion.

**7.4.1.2 FRP Tendon Design Properties.** Of the three common FRP tendon materials (glass, aramid, and carbon), research data has shown that carbon fiber prestressing tendons have performed best, to date, in a seawater environment. Aramid fiber prestressing tendons may also be acceptable if creep and moisture absorption can be controlled. Glass fiber prestressing tendons are not recommended because of their deterioration in alkaline (concrete) and saltwater environments.

This effort focused initially on the carbon fiber prestressing tendons as an alternate to steel prestressing tendons. In the course of this work, it was concluded that FRP tendon technology and the associated anchorages and stressing equipment is not mature enough yet to recommend for use as a primary reinforcement for a structure to be built full scale in the near term. It is recommended that continued development of CFRP prestressing tendons be carried out. If this development proceeds successfully at a pace faster than currently expected and the cost of these tendons is competitive with encapsulated steel tendons, they will be considered for use as global prestressing material for the floating pier.

**7.4.1.3 CFRP Tendon Design Properties.** Carbon prestressing tendons are currently available as rods and flat bars. Because the tendons are typically pultruded, almost any shape of cross section can be fabricated if the need arises. While the technology exists to produce high quality CFRP tendons, the development of a complete commercial CFRP post-tensioning system with the necessary structural reliability and corrosion resistance is not yet complete.

The individual carbon fibers typically have an ultimate tensile stress on the order of 400 to 500 ksi (2,700 to 3,500 MPa). This is likely to change, as manufacturers have recently increased the strength of the fibers available on the market and stopped production of the lower strength materials. A tendon is comprised of a matrix consisting of fibers in a polymer binder, typically epoxy. The tendon derives its strength from the FRP fibers, not the binder. The volume fraction of fibers in a tendon cross section typically ranges from 60 to 65 percent. Hence, strength of a CFRP tendon based on the gross cross-sectional area can be derived as follows:

$$f_{pu} = 500 \text{ ksi} \times 0.60 \text{ (fiber content)} = 300 \text{ ksi (2,070 MPa)}$$

When using FRP prestressing tendons, a phenomenon called creep rupture must be considered. *“Under loading and adverse environmental conditions, FRP reinforcing bars and tendons subjected to the action of a constant load may suddenly fail after a time, referred to as endurance time”* (Ref 7). Some FRP materials are more susceptible to creep rupture than others. Initial test results indicate that properly configured CFRP tendons are less susceptible to creep rupture than most other FRP materials. Creep rupture is dependent on the initial (and sustained) stress levels in the material. Generally, creep rupture can be prevented if the initial stress levels are kept below 50 percent of the ultimate tensile stress. Hence, for design, a maximum stress level for CFRP tendons is recommended as follows:

$$f_{se} = 0.50 \times 300 \text{ ksi} = 150 \text{ ksi (1,035 MPa)}$$

Geometry (cross section) of the prestressing tendon may also play a role. There appear to be benefits to using flat strips versus the conventional round rods for prestressing applications. The stress gradient due to local bending of the tendon can cause the outer fibers in circular cross section tendons, or any tendon having a substantial depth relative to the bending radius, to

rupture. This is particularly important for harped tendons or those bent around a small radius. The Canadian code provides a formula for reducing the allowable tension in the tendon based on tendon thickness and bend radius:

$$\text{Reduction factor} = 0.5 \times E_{FRP} \times d_b / R_t$$

where:

- Radius of curvature less than  $1,200d_b$
- $E_{FRP}$  = modulus of elasticity of material
- $d_b$  = bar diameter
- $R_t$  = bend radius

**7.4.1.4 Bond of CFRP Tendons.** Carbon fiber tendons typically have a shorter bond development length (high bond stresses) in concrete than conventional steel prestressing tendons. This can result in cracks or delaminations in the concrete near the prestressing anchorage areas. Additional confining reinforcement will be required in these areas. Other solutions for dealing with the effects of short development length should also be investigated. Bonded tendons would be used in thin, plate elements. Bonded or unbonded tendons could be used in deeper beam elements.

## 7.4.2 FRP Reinforcement Properties

Carbon rods are significantly stronger than mild steel reinforcement of equivalent size. It is, therefore, possible to develop equivalent section capacity through the use of fewer carbon rods and at significantly larger spacing. This approach is not desirable because it could result in large crack widths under flexural loading. A concept that has been experimented with and which is recommended for use on this project is to use an open mesh made from carbon material of small diameter (similar to welded wire fabric). This provides a fairly close spacing of reinforcement to control cracking and makes maximum use of the greater strength of carbon fibers.

Technical information and independent testing on these materials is very limited. Engineering data used in this program was based on information received from fiber manufacturers. Because this type of material is typically subjected to lower stresses than the prestressed reinforcement, it may be possible to use other types of materials, including aramid and glass fiber meshes.

**7.4.2.1 FRP Reinforcement Design Properties.** Carbon reinforcement is typically available in prepreg sheets and tape. Several manufacturers have been experimenting with a woven open-mesh type of material. The composite materials can be pultruded or more commonly field impregnated with resin. Almost any shape of cross section can be fabricated if the need arises. The individual carbon fibers that compose the mesh typically have an ultimate tensile stress on the order of 400 to 500 ksi (2,700 to 3,500 MPa). As with the tendon material, this is likely to change as manufacturers have recently increased the strength of the fibers available on the market and have stopped making the lower strength materials.

A sheet or tape type of composite material is comprised of a matrix consisting of fibers in a polymer binder, typically epoxy. The composite derives its strength from the FRP fibers, not the binder. The volume fraction of fibers in a cross section typically ranges from 50 to 65 percent. The volume fraction for an open-mesh type material is estimated to be at the lower end of the range. Because of the large variation possible in sheet type materials, manufacturers typically rate the composite by strength rather than stress.

Hence, for design, a maximum strength  $T_{se}$  is recommended as follows:

$$T_{se} = \text{rated load} \times 0.50$$

See Section 7.5 to the report for additional design criteria.

### **7.4.3 Lightweight Concrete Design Properties**

The use of high-strength sand lightweight concrete is proposed. A recommended concrete mix design is presented in Section 8.2.6. Because of the importance of consistency in mixing, batching, and placing lightweight materials, the use of lightweight concrete should be limited to factory-produced precast concrete and elements constructed in fabrication yards with good quality control.

Recommended strength, 56 days,  $f'_c = 8,000$  psi (55 MPa)

Density, fresh, 115 ~ 120 pcf (1.84 ~ 1.92 T/m<sup>3</sup>)

## **7.5 APPROACH DEVELOPED FOR DESIGN OF CFRP REINFORCED SECTIONS**

The following approach was developed specifically for this program in order to define a design method that takes advantage of the properties of CFRP materials while providing the type of structural behavior needed for permanently floating concrete structures.

### **7.5.1 Introduction**

CFRP materials are high-strength, reasonably high modulus noncorrosive materials that should have high potential for use in concrete infrastructure projects. Unfortunately, the high strains associated with high stresses have inhibited the use of these high-strength materials.

The purpose of this section is to suggest a way to efficiently use CFRP as the tensile reinforcement for slab-like concrete elements.

### **7.5.2 Design Philosophy**

A tough and durable composite member is needed, composed of high-performance lightweight concrete and carbon fiber composite reinforcing. The member needs to have good performance (minimal cracking, low or moderate deflection) at service loads, but it should have much greater cracking and deflection prior to reaching its ultimate strength. This is necessary to

give warning of overloading in the case of static loads, and to absorb energy in the case of dynamic loads.

Much has been made of the fact that carbon and other synthetic materials have no yield point, and they are thus classified as "brittle" materials. Nevertheless, it is possible to design a prestressed concrete member capable of undergoing large strains and deflections prior to failure, without yielding of the tensile reinforcement. This was demonstrated in the prestressed fender pile program previously developed at NFESC (formerly NCEL). Through the use of prestressing, the deflection and cracking at service load may be minimized, giving the desired change in behavior between service and ultimate loads.

The use of prestressing to solve the problem of very high strains in high-strength tension reinforcing materials is well understood. The problem of how to efficiently make use of the tensile capacity of high-strength materials in nonprestressed applications has remained unsolved. One possibility is to use the high-strength material in the form of a mesh (or grid or net or scrim). This resembles the principles used in ferrocement boat building. If the reinforcement is sufficiently finely dispersed in the concrete matrix, the composite steel and concrete material behaves somewhat as a monolithic uncracked material, even though the concrete must theoretically be cracked. However, as the tensile strains increase, there comes a point at which the behavior trends toward that of the net section properties of the tensile reinforcement.

Thin wall concrete members for use in housing are being made using glass FRP mesh for reinforcement near each face. These members are reputed to be extremely tough. But quantitative data are not available. One paper has been published on tests of carbon fiber mesh (see next subsection) to control cracking. The results encourage one to believe that higher strains at service load can be tolerated, provided the reinforcement is near the surface, and in the form of a mesh. The noncorrosive property of CFRP allows it to be placed close to the surface.

It appears that the ideal concrete-CFRP member will consist of a prestressed CFRP tendon combined with unstressed CFRP mesh reinforcement placed close to each face. The goal is to find the proper combination that will produce the desired behavior at service load, but take maximum advantage of the full potential of CFRP at ultimate load.

### **7.5.3 Analysis of Makizumi, Sakamoto, and Okada Paper**

Makizumi, Sakamoto, and Okada (M-S-O) published a paper "Control of Cracking By Use of Carbon Fiber Net as Reinforcement for Concrete" in ACI SP-138, Fiber-Reinforced-Plastic Reinforcement for Concrete Structures, 1993 (Ref 8). It describes the use of a bonded carbon fiber square mesh to control cracking at strains above cracking in a prestressed member. The mesh had elements spaced at 3/4 inch (20 mm). The mesh was placed very close, 1/8 inch (3 mm) to the tension surface of the 3-1/8-inch (80-mm) thick model concrete sheet pile. The elements of the mesh in the direction of stress had an area of carbon fiber equal to 0.00088 times the gross concrete area.

At various stress levels, the presence of the carbon mesh reduced crack widths by more than 50 percent, compared to comparable specimens without the carbon mesh. At tensile strains in the carbon of 0.0032 (BERGER/ABAM estimate), crack widths were 0.004 inch (0.10 mm). It is hard to know how to scale this up to a full-sized structure. But, flexural crack widths more than twice this amount could be acceptable. Thus, it appears that through the use of a CFRP mesh near the surface, satisfactory behavior at service load could be obtained at a strain of twice the 0.0012 strain in Grade 60 steel reinforcement at 36-ksi (248-MPa) service load stress. Thus,

a limiting strain in the carbon fiber net at service load of 0.0024 has been tentatively selected. It is also assumed that a minimum area of carbon fiber of 0.0008 times the gross concrete area will be provided in the direction of stress.

#### 7.5.4 Assumed Material Properties for Analysis

The following material properties were assumed. The assumed properties of carbon fiber are based on information furnished by Toray Industries, Inc. (Ref 9).

##### Concrete

Lightweight, density  $\gamma_c = 120 \text{ lb/ft}^3$  ( $1.92 \text{ T/m}^3$ )

Strength,  $f'_c = 8,000 \text{ psi}$  ( $55 \text{ MPa}$ )

Modulus of elasticity  $E_c = 3,880 \text{ ksi}$  ( $26.8 \text{ GPa}$ ) (per ACI code)

Ultimate strain  $\epsilon_{cu} = 0.003$

Trapezoidal stress block

Maximum stress  $f_{max} = 0.85 f'_c = 6.8 \text{ ksi}$  ( $46.9 \text{ MPa}$ )

Strain at maximum stress  $\epsilon_{co} = 0.00175$

Modulus of rupture  $f_r = 0.85 (7.5 \sqrt{f'_c}) = 570 \text{ psi}$  ( $3.9 \text{ MPa}$ )

##### Carbon Fiber Composite – Properties Based on Net Section of Carbon Fiber

Density  $\gamma_f = 1.8 \text{ g/cm}^3 = 112 \text{ lb/ft}^3$  ( $1.79 \text{ T/m}^3$ )

Strength  $f'_f = 450 \text{ ksi}$  ( $3,100 \text{ MPa}$ )

Modulus of elasticity  $E_f = 30,000 \text{ ksi}$  ( $207 \text{ GPa}$ )

Ultimate strain  $\epsilon_{fu} = 0.015$

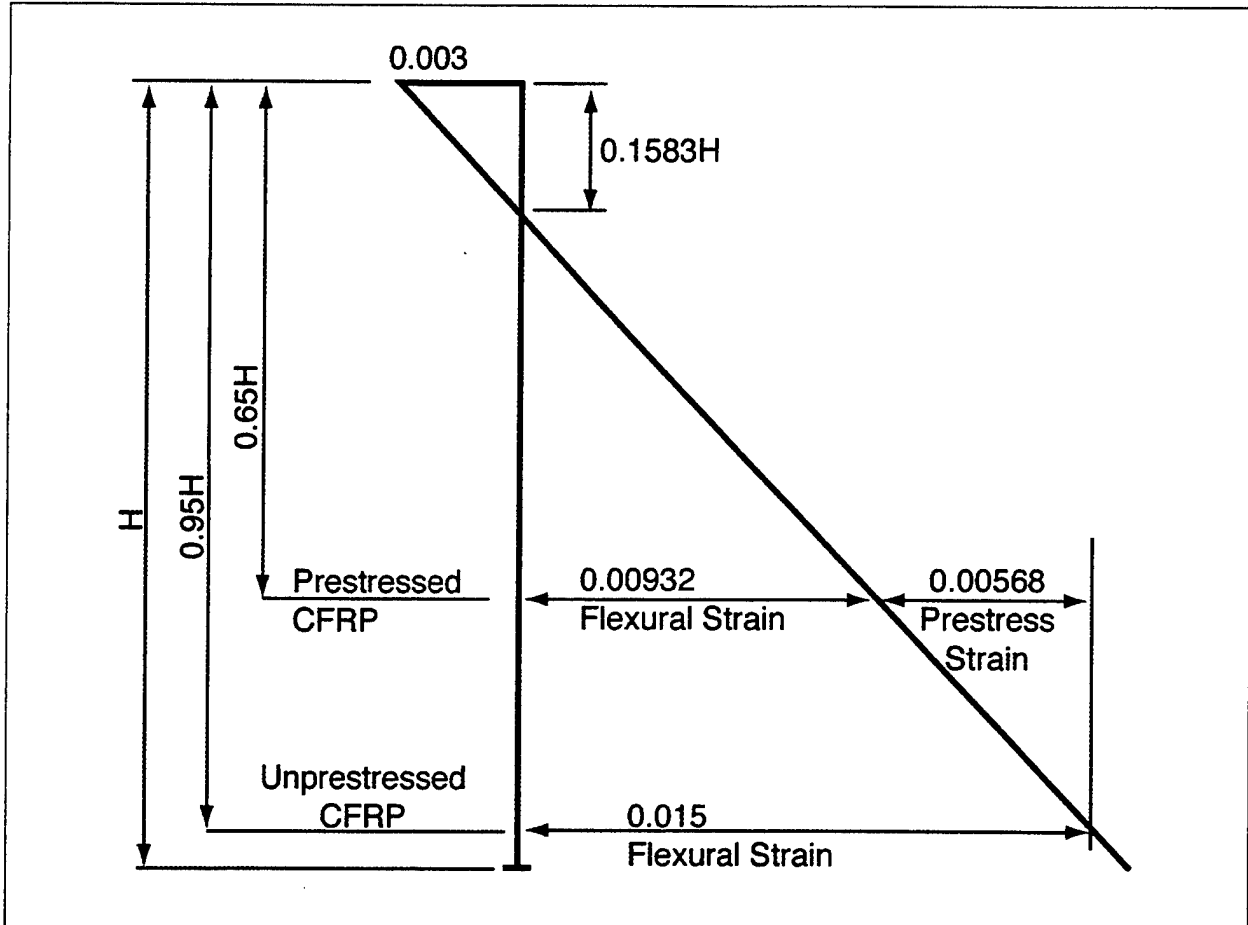
Linear elastic behavior to failure

These strength and modulus properties are somewhat greater than those reported in the M-S-O paper.

#### 7.5.5 Balanced Condition

The balanced condition may be defined as a condition in which the concrete and CFRP materials reach their ultimate strains simultaneously. Background computer output is provided in Appendix C. Figure 7-3 shows a strain diagram for this state. It is assumed that the unprestressed CFRP mesh is placed at  $0.05H$  from the tension face, and the prestressing is placed  $0.65H$  from the compression face (this is approximately at the kern). The flexural strain at that level is 0.009316. If the prestress tendons are prestressed to a strain of the ultimate tensile strain less this amount, the prestressed tendon will reach its ultimate strain simultaneously with the concrete and the unstressed CFRP near the tension face.





**Figure 7-3**  
**Balanced Condition Strains**

Figure 7-4 shows the stress block in the concrete at balanced condition. The compression force in the trapezoidal stress block is equal to  $0.762H$ . The area of carbon fiber needed to develop this may be found by dividing by the 450-ksi (3,100-MPa) ultimate strength. The required ratio of carbon fiber to concrete, by volume, is 0.001694. This amount of carbon fiber may be placed in the tendon, in the unprestressed mesh, or divided between the two locations.

In order to create a reasonably sized "unit" section of slab, a section 10 inches (254 mm) thick and 12 inches (305 mm) wide, spanning 20 feet (6.1 m) was assumed. Uniform loading on a simple span was assumed for this study, in the interests of simplicity. Of course, in a real structure, the slabs may be continuous. The area of carbon fiber reinforcement is equal to the concrete area times 0.001694, or  $0.2032 \text{ in.}^2$  ( $131 \text{ mm}^2$ ). Three flexural specimens were investigated, one with all the carbon fiber unprestressed, one with all prestressed, and one with 0.0008 times the gross area unprestressed and the remainder prestressed. These are called Cases 1, 2, and 3, respectively.

Figure 7-5 shows the moment-deflection curves for Cases 1 through 3. The all-nonprestressed member shows the greatest nominal strength, because the lever arm is greater for tensile reinforcing near the surface. But, if we postulate a limiting strain of 0.0024 at service load, the service load moment is only 11 percent of the nominal strength. Thus, service load would control, and the much greater nominal strength could not be utilized in the design.

Case 2, all prestressed, is plotted for the sake of completeness. In reality, we would not use a design without some unprestressed reinforcement near the surface.

For the combination prestressed and nonprestressed member of Case 3, the nominal strength moment is decreased, relative to the nonprestressed member of Case 1. The service load moment (based on 0.0024 strain) is increased, and is 16 percent of the nominal strength moment. To have service and ultimate limit states equally controlling, it is desirable to have the service load moment capacity be about 60 percent of the nominal strength capacity.

The problem is that the prestress is too low. This was so, even with the all-prestressed model of Case 2. Of course, the service load strain limit of 0.0024 was arbitrarily chosen, based on very meager data. If this strain limit could be increased, based on yet-to-be researched data on methods of beneficially detailing the nonprestressed reinforcement mesh, the problem could be solved.

It should be noted that the use of high-performance concrete is essential to making the system work efficiently. Were the concrete strength lower, the reinforcement ratios and prestressing would also be lowered.

Another approach is to increase the prestressed reinforcement, making the section over-reinforced. This is not as bad as the word "over-reinforced" might imply. In fact, some researchers have advocated over-reinforcement, on the assumption that crushing of the concrete is a more desirable failure mode than fracture of the tendons.

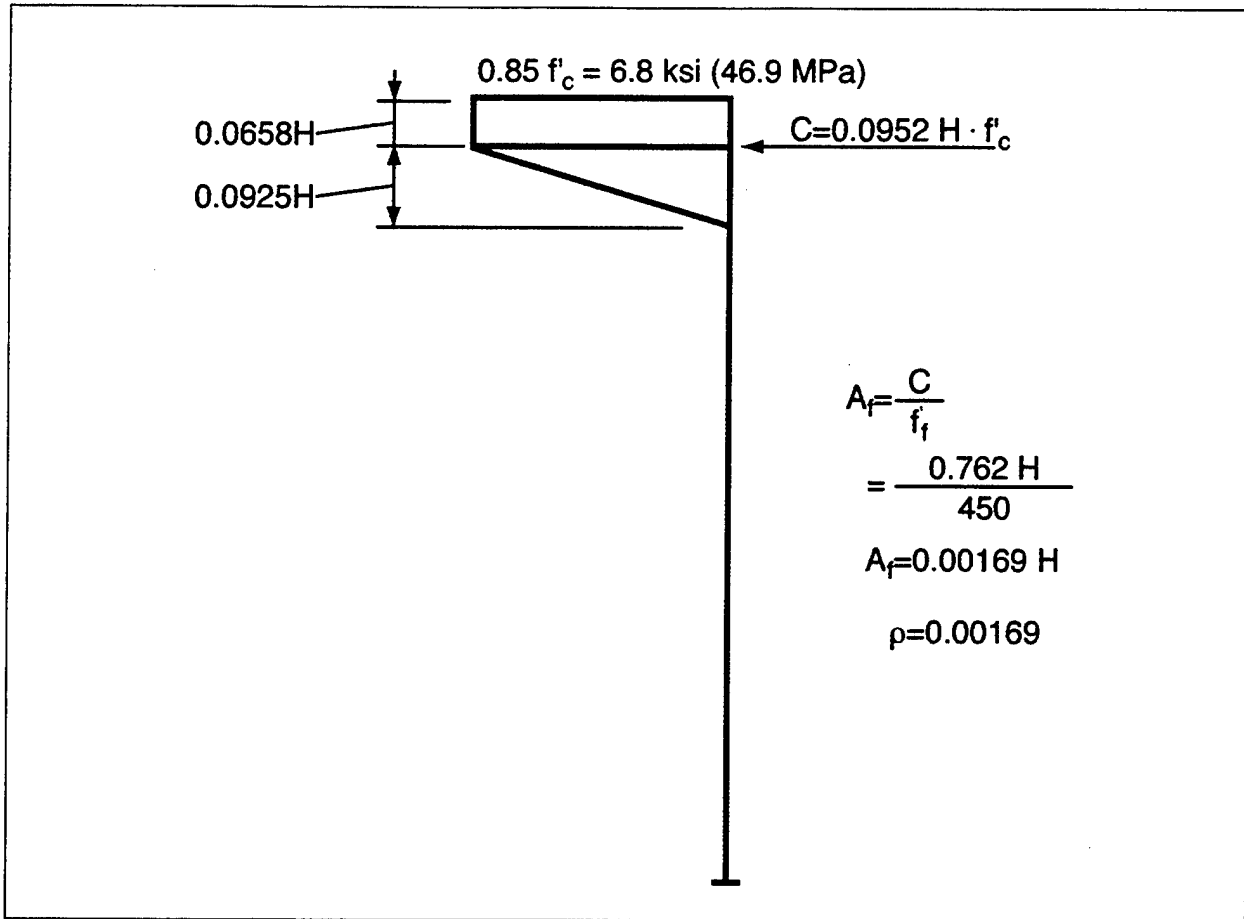
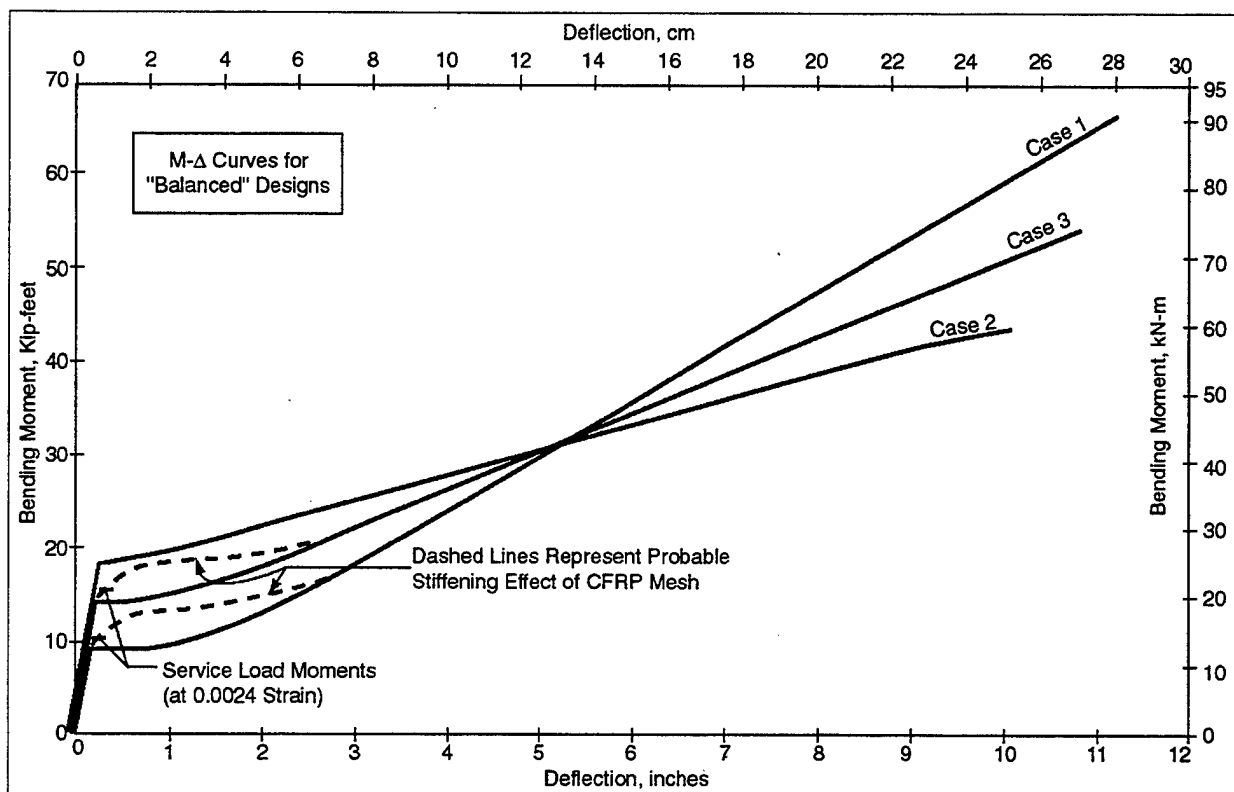


Figure 7-4  
Balanced Condition Stress



**Figure 7-5**  
**M-Δ Curves for "Balanced" Designs**

### 7.5.6 Effect of Increasing the Prestressing

In order to increase the permissible moment at service load, the prestress needs to be increased to control tensile strains at service load to the assumed limit of 0.0024. The first step is to use the same configuration as in the balanced condition with a combination of prestressed and unstressed carbon fiber, and increase the prestress level up to the maximum permissible. Some researchers advocate using a maximum prestress of 40 percent of ultimate, in order to avoid the possibility of creep rupture. The prestress level is increased to 180 ksi (1,240 MPa), 40 percent of the ultimate strength. This causes the prestressed tendon to rupture prior to reaching a balanced state, and it slightly reduces the moment and deflection at nominal strength. This case is called Case 4. The strains at nominal strength are illustrated in Figure 7-6. The section still has adequate margin for moment and deflection between the service and ultimate states. Because the prestress level was 170 ksi (1,170 MPa) in Case 3, increasing it to 180 ksi (1,240 MPa) causes Case 4 to be little different from Case 3.

The next step is to increase the amount of prestressed carbon fiber. This results in an ultimate condition of concrete crushing prior to the CFRP reaching its full strength. The working load moment is increased 80 percent by a 67 percent increase in the total amount of carbon fiber. This is called Case 5.

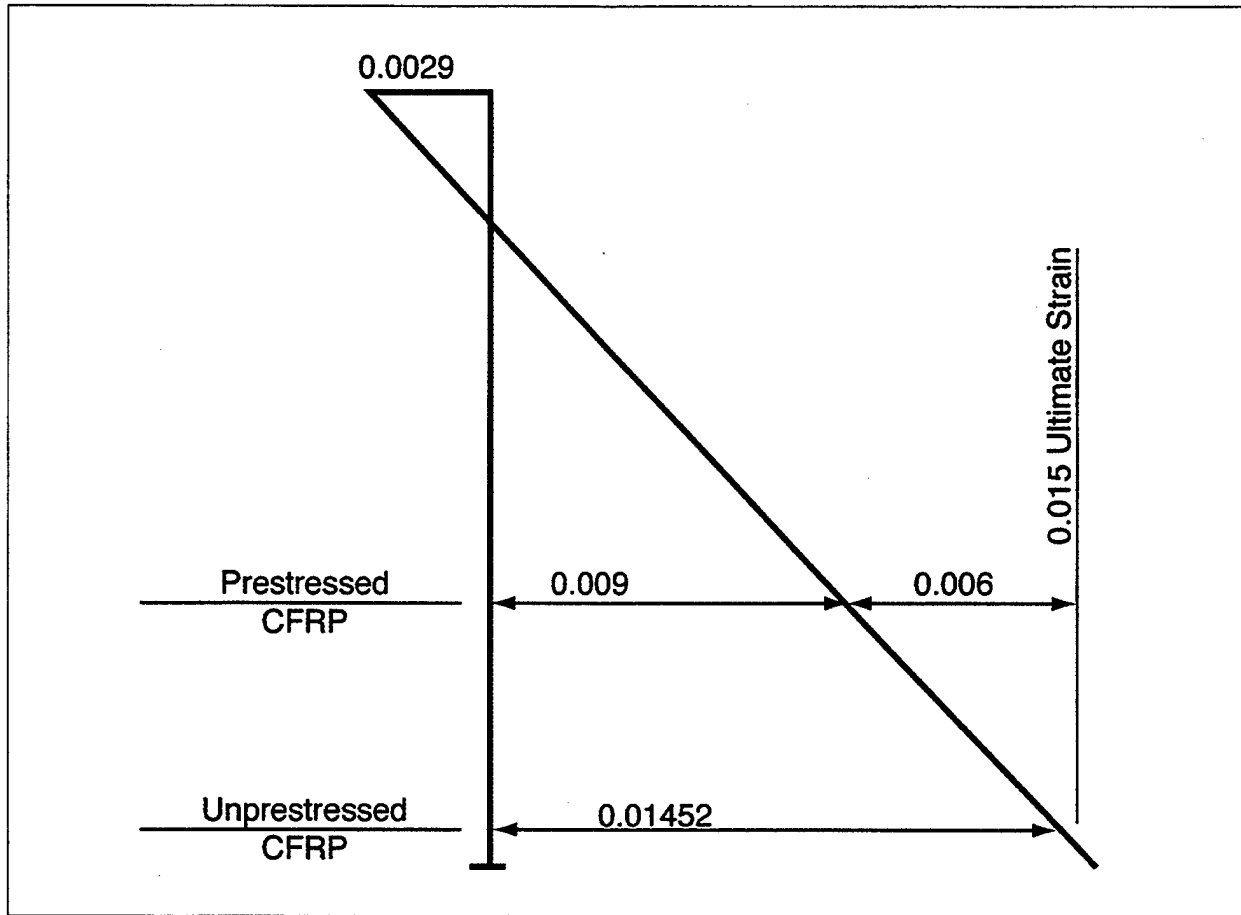
The prestress may be further increased to the point where the permissible service load moment is about 60 percent of the nominal strength. This requires an additional 50 percent increase in carbon fiber content, and results in about the same percentage increase in permissible service load moment. This is called Case 6. The strains at nominal strength are shown in Figure 7-7. The moment-deflection curve for this case is shown in Figure 7-8. There is little point in increasing the prestressing further, because nominal strength could then control. However, increases in both the prestressed and the unstressed carbon fiber could be made, maintaining a balance between service load and nominal strength capacities.

It should be noted that the capacities appear to be more than adequate for hull components. For the last section described, the service load moment is 45.3 kip-ft (61.4 kN-m) for a 1-foot (0.30 m) wide strip. For the midspan moment of a continuous plate on a 20-foot (6.1-m) span, with moment of about  $w\lambda^2/24$ , the permissible service load,  $w$ , would be 2.81 ksf (134 kPa). For a 20-foot (6.1-m) head, the actual service load,  $w$ , would be  $0.064(20) = 1.28$  ksf (61 kPa). The assumed 10-inch (259-mm) thickness might be reduced to  $\sqrt{(1.28/2.81)} \times 10$  inches = 6.75 inches, say 7 or 8 inches (178 or 203 mm).

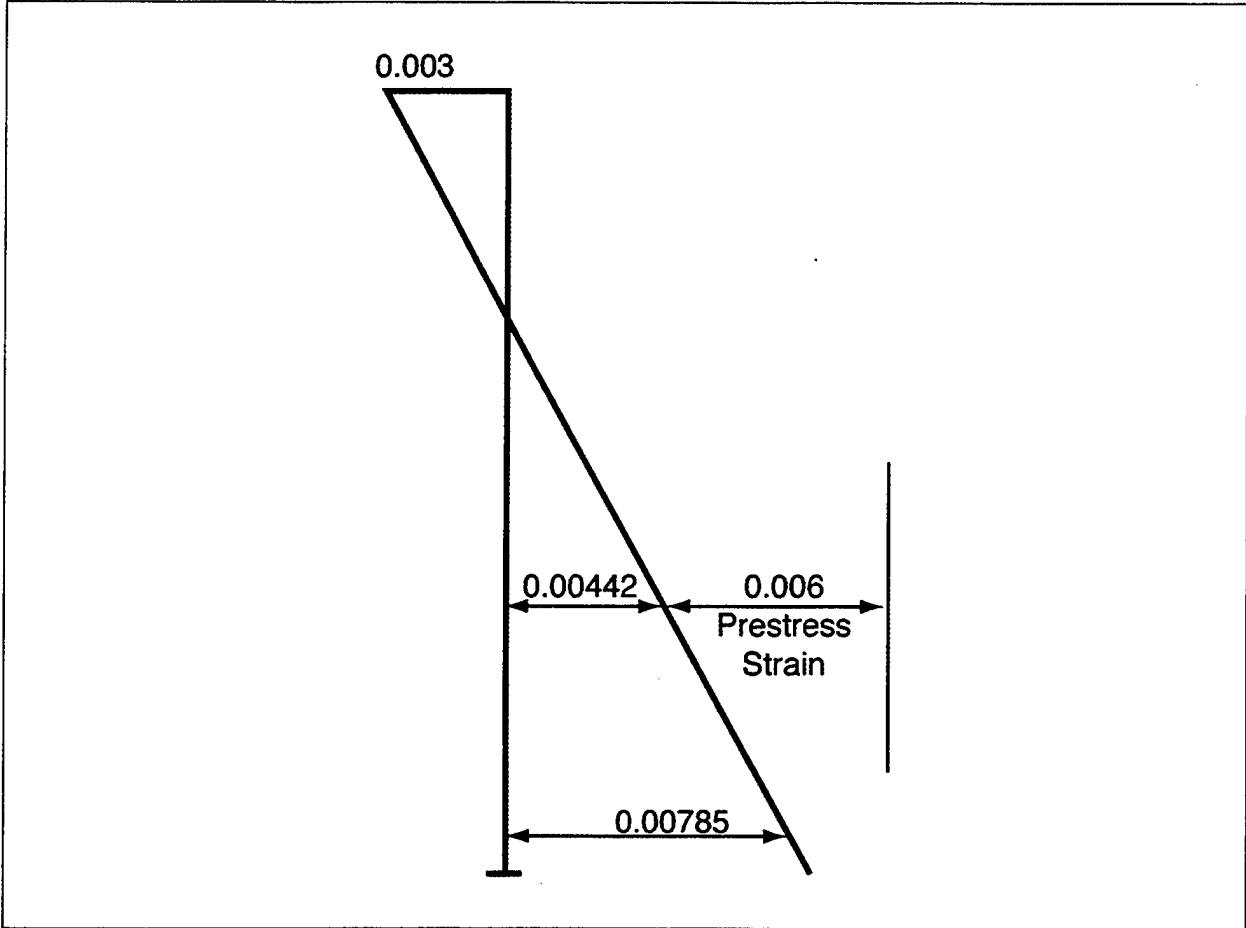
The potential reduction of the minimum thickness of members, resulting from the lack of necessity to provide minimum cover for corrosion protection, was perceived to be an important advantage of CFRP used as reinforcing in concrete. It appears that this may be realized.

### 7.5.7 Cost Comparisons

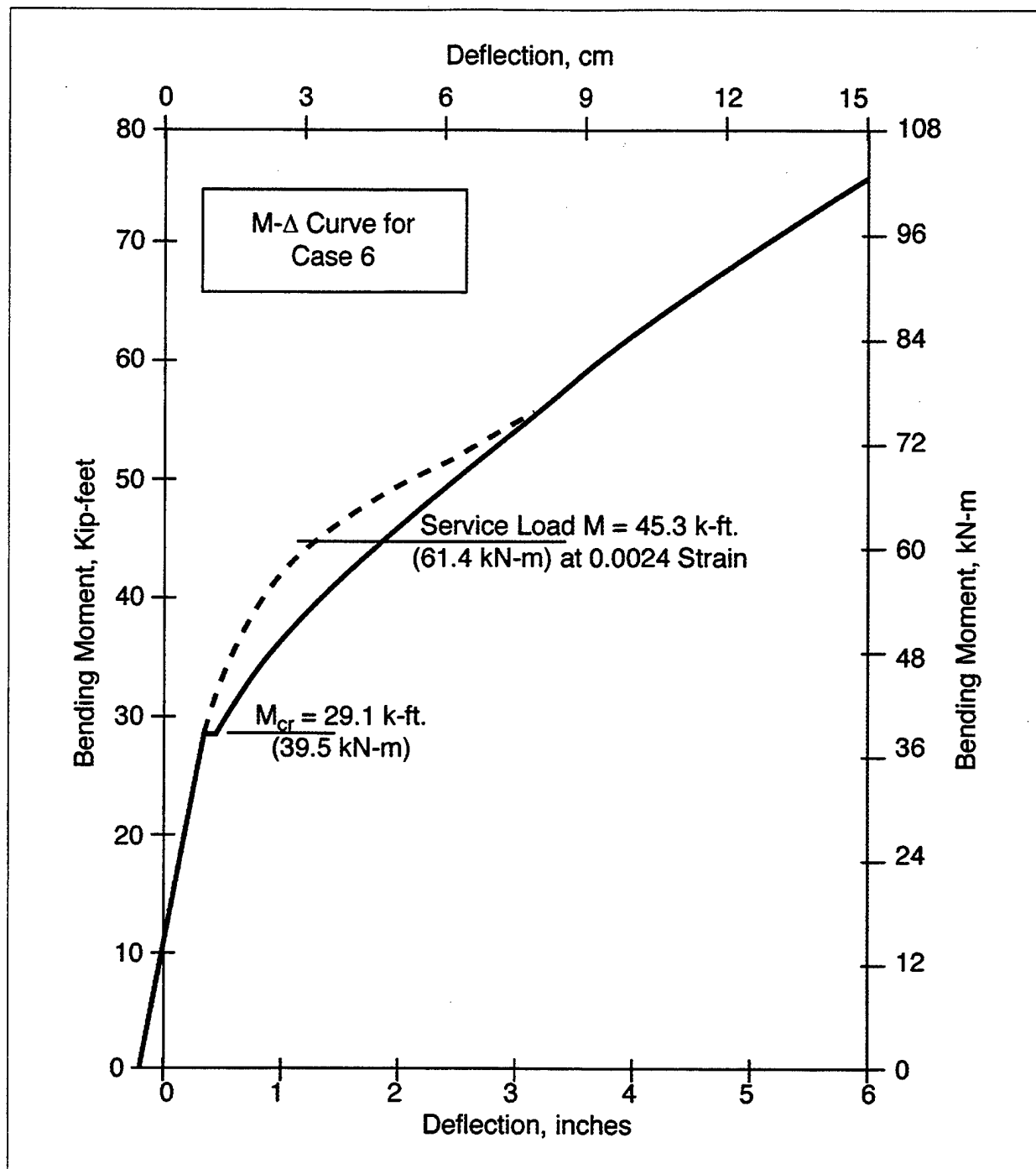
In designing reinforced concrete slabs, it is found that economy often argues against using the minimum concrete thickness. By using a greater-than-minimum thickness, the cost savings in reduced reinforcement can more than offset the additional cost of extra concrete. Considering the high cost of CFRP, the cost of additional capacity gained by increasing the CFRP content should be investigated.



**Figure 7-6**  
**Strains in Case 4 - Tendon Rupture Controls**



**Figure 7-7**  
**Strains in Case 6 – Concrete Crushing Controls**



**Figure 7-8**  
**M-Δ Curve for Case 6**

Service Load Moment ~ 60% of Nominal Strength



For this simplified study, only the basic material costs are considered. They are assumed to be:

High-performance lightweight concrete	\$4 per cf (\$108 per cy)	(\$141 per m <sup>3</sup> )
Cost of carbon fiber	\$8/lb	(\$18/kg)
Cost of CFRP (including carbon fiber, resin, and fabrication)	\$20/lb	(\$44/kg)

The assumed costs of carbon fiber and CFRP are based on information provided by Toray (Ref 10). Assume CFRP is 50 percent by volume carbon at a specific gravity of 1.8, and 50 percent resin at a specific gravity of 1.2. Then, 3 pounds (1.4 kg) of CFRP contains 1.8 pounds (0.8 kg) of carbon fiber. The cost of 3 pounds (1.4 kg) of CFRP is \$60. The cost of CFRP per pound of carbon fiber is \$60/1.8 = \$33.33 per pound (\$73.41 per kg) of carbon fiber.

For comparison, basic material costs for steel are:

Prestressing tendons (encapsulated)	\$2.50 per lb (\$1,225 per cf of strand)	(\$5.50 per kg)
Epoxy-coated reinforcement	\$0.50 per lb (\$245 per cf)	(\$1.10 per kg)

These costs consider only raw material costs. We did not attempt to estimate all-in final costs at this time.

For cost estimating, it is useful to convert the cost of reinforcement to the cost of a unit volume of material, 1 foot long.

$$\text{Cost per in}^2\text{-ft} = \frac{\text{Cost/ft}^3}{144} = \frac{\text{Cost/lb} \times \text{lbs/ft}^3}{144} = \frac{\text{Cost/lb} \times \text{s.g.} \times 62.4}{144}$$

<u>Material</u>	<u>Cost per in<sup>2</sup>-ft</u>
Cost of CFRP per in <sup>2</sup> -ft of carbon fiber	\$26.00
Prestressing tendons (encapsulated)	\$8.50
Epoxy-coated reinforcement	\$1.70

Table 7-1 shows the material costs for three degrees of CFRP reinforcement, per kip-ft (kN-m) of useful service load capacity. For a given bending moment, the thickness would need to be varied for the different design cases. For a fixed reinforcement ratio, the moment capacity varies as the square of the thickness. Table 7-2 shows the results for a fixed moment capacity.

Table 7-2 indicates a slight cost advantage for using greater thicknesses, but the difference is small. There are other advantages to be gained by saving weight, particularly in a floating structure. Considering these, the overall costs of slabs of various thicknesses may be similar.

**Table 7-1**  
**Cost Variation with Degree of CFRP Content**  
**on a 10-Inch (254-mm) Thick Section, 1 Foot (305 mm) Long**

Case	Working M (k-ft)	CFRP Area	CFRP Cost (\$)	Concrete Cost (\$)	Sum (\$)	Unit Cost (\$/kip-ft)
4	16.7	0.2032	5.28	3.33	8.62	0.516
5	30.0	0.3400	8.84	3.33	12.17	0.406
6	45.3	0.5090	13.23	3.33	16.57	0.366

Conversion: 1 k-ft = 1.356 kN-m  
1 in. = 25.4 mm

**Table 7-2**  
**Cost Variation for Constant Moment of 30 k-ft (40.7 KN-m)**  
**(Thickness is varied to produce constant moment)**

Case	Thickness (in.)	CFRP Area	CFRP Cost (\$)	Concrete Cost (\$)	Sum (\$)	Unit Cost (\$/kip-ft)
4A	13.40	0.2724	7.08	4.67	11.75	0.392
5	10.00	0.3400	8.84	3.33	12.17	0.406
6A	8.14	0.4142	10.77	2.71	13.48	0.449

Conversion: 1 k-ft = 1.356 kN-m  
1 in. = 25.4 mm

### **7.5.8 Comparison to All-Steel Design**

It is useful to compare the CFRP designs to conventional designs using steel. For steel designs with extra-long life comparable to that expected of noncorrosive CFRP, the following were assumed:

1. Prestressing to eliminate flexural tension at service load.
2. Use of epoxy-coated reinforcement with 2-inch (51-mm) minimum cover, with an area of 0.002 times the gross concrete area.
3. Use of bonded steel tendons electrically isolated from the surrounding concrete by a closed encapsulation of synthetic materials.

Table 7-3 shows the results. The steel designs are somewhat less, but not a lot less, costly than the CFRP designs. The above assumptions increase the steel cost, compared to a "conventional" prestressed slab.

### **7.5.9 Hybrid Steel Carbon Designs**

Another possibility is to use encapsulated steel tendons for the post-tensioning, but to use the carbon mesh for the nonprestressed reinforcement. This combines the best characteristics of the two materials. Steel post-tensioning tendons are more than three times as efficient in cost per kip of prestressing force, compared to CFRP tendons. And, the steel tendons can be well protected from corrosion by large concrete cover and by encapsulation. The carbon mesh can be placed near the surface where it is most efficient in the control of cracking, and where it provides maximum resistance to flexure.

With the lack of steel near the surface and the crack control provided by the CFRP mesh, the zero tension requirement used in the all-steel design was eliminated and replaced by the 0.0024 maximum strain at service load used in the all-carbon design. Table 7-4 shows the results. Maximum economy is obtained using the hybrid design, as illustrated in Figure 7-9.

### **7.5.10 Discussion of Results**

Figure 7-9 shows the costs for all-carbon, all-steel, and hybrid designs. Some remarks are in order:

1. The all-carbon and hybrid designs were based on a tensile strain limit of 0.0024 at service load. Testing is needed to verify whether the CFRP mesh can produce satisfactory behavior at this strain level.
2. The all-carbon designs were based on a prestress level of 40 percent of 450 ksi (3,100 MPa) in the CFRP tendons.

**Table 7-3**  
**Cost Comparison of All-Steel Design**  
**(For a service load moment of 30 k-ft (40.7 kN-m))**

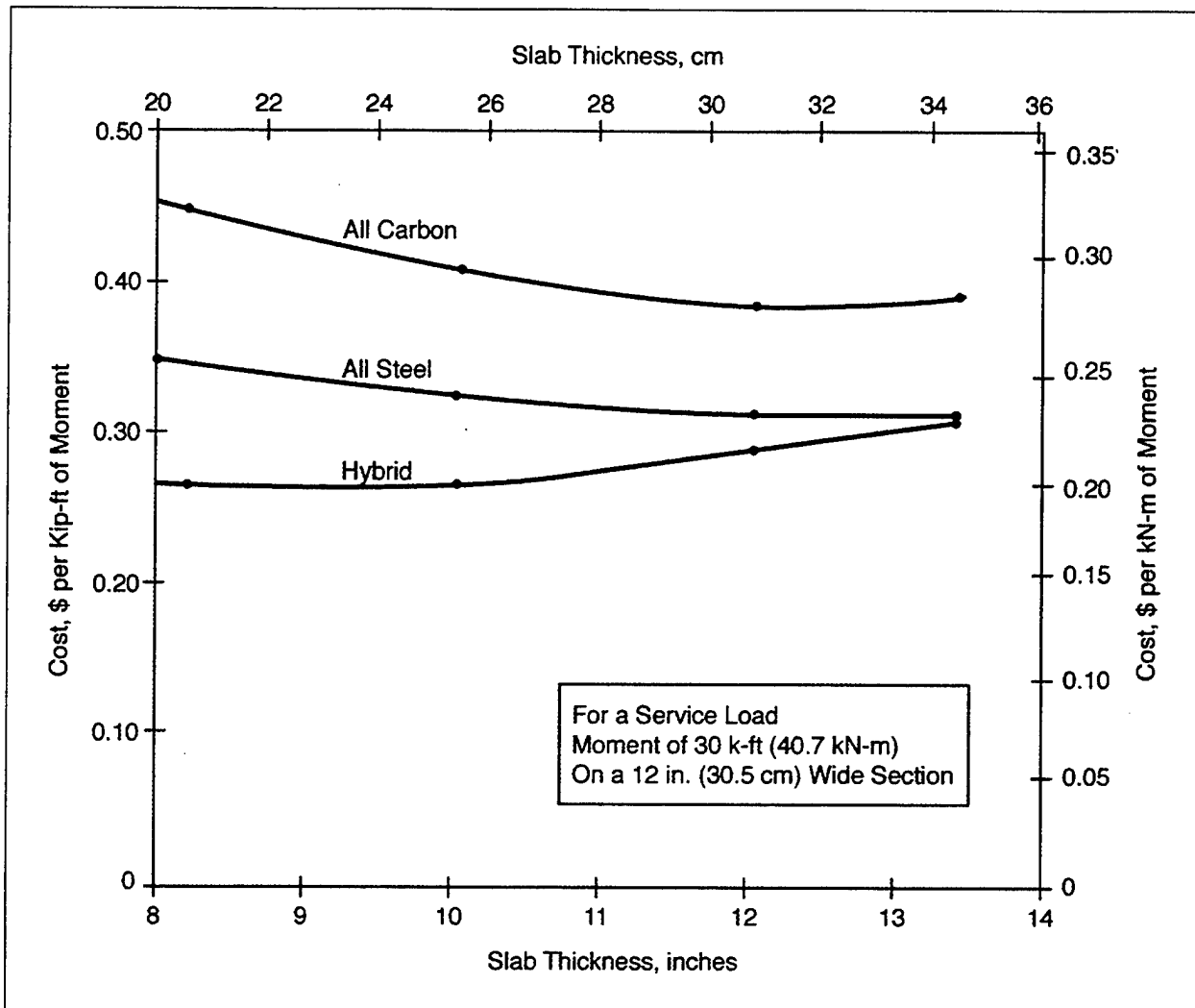
Case	Thickness (in.)	PT Area (in. <sup>2</sup> )	Rebar Area (in. <sup>2</sup> )	PT Cost (\$)	Rebar Cost (\$)	Concrete Cost (\$)	Sum (\$)	Unit Cost (\$/kip-ft)
7	12	0.585	0.288	4.97	0.49	4.00	8.97	0.315
8	10	0.702	0.240	5.96	0.41	3.33	9.71	0.327
9	8	0.877	0.192	7.46	0.33	2.67	10.45	0.348

Conversion: 1 k-ft = 1.356 kN-m  
1 in. = 25.4 mm

**Table 7-4**  
**Hybrid Design – Steel PT Plus Carbon Grids**  
**(For a service load moment of 30 k-ft (40.7 kN-m))**

Case	Thickness (in.)	PT Area (in. <sup>2</sup> )	Carbon Area (in. <sup>2</sup> )	PT Cost (\$)	Carbon Cost (\$)	Concrete Cost (\$)	Sum (\$)	Unit Cost (\$/kip-ft)
10	13.40	0.1581	0.1287	1.34	3.35	4.67	9.36	0.312
11	10.0	0.2638	0.0960	2.24	2.50	3.33	8.07	0.269
12	8.14	0.3715	0.0781	3.16	2.03	2.71	7.90	0.263

Conversion: 1 k-ft = 1.356 kN-m  
1 in. = 25.4 mm



**Figure 7-9**  
**Cost Comparison**

3. The costs of the all-steel designs were impacted by the high amount of post-tensioning needed to satisfy the zero tension criterion.
4. The tensile strain limit of 0.0024 at service load may be too liberal for the hybrid design. At this strain level in the CFRP mesh, the steel tendon would theoretically be in a zone of tension in the concrete. For corrosion protection, one would have to rely on thick cover and the synthetic encapsulation material.

If it were deemed necessary to limit tensile stresses in the concrete, additional prestressing would be needed. This could increase the cost of the hybrid design. However, if less tension is permitted, the quantity of CFRP might be reduced.

5. The cost per kip-ft (kN-m) of useful service load moment capacity is too sensitive to the concrete thickness chosen.
6. The assumed price of the CFRP is based on that which might prevail in the next year or two, for a civil engineering grade of CFRP, based on information provided by Toray (Ref 10) and Zoltek Industries, Inc. (Ref 11). The cost comparisons are obviously dependent on the CFRP cost used in the analysis.

#### **7.5.11 Conclusions**

It appears that CFRP can be efficiently used as concrete reinforcement. An important yet-to-be-proved assumption is its effectiveness in modifying behavior and controlling cracking well beyond the theoretical cracking load. The research data base on this subject is very limited. More research on this concept will need to be done in or parallel to Phase 2 of this project.

It appears that the hybrid design is the most promising. It combines the proven strength and efficiency of steel post-tensioning with the potential of carbon fiber grids for controlling flexural cracking and adding toughness.

#### **7.6 REFERENCES**

1. Naval Facilities Engineering Command. Military Handbook 1025/1: Piers and Wharves. 30 October 1987.
2. Naval Civil Engineering Laboratory. User's Guide UG-0007: Advanced Pier Concepts. Port Hueneme, CA, October 1985.
3. American Association of State and Transportation Officials (AASHTO). A Policy on Geometric Design of Highways and Streets. Washington, DC, 1994.
4. International Conference of Building Officials. Uniform Building Code. Whittier, CA, 1997.

5. American Concrete Institute. ACI 318 Appendix B: Unified Design Provisions for Reinforced and Prestress Concrete Flexural and Compression Members. Farmington, Hills, MI, 1995.
6. American Society for Testing and Materials. ASTM A 416. West Conshohocken, PA, 1998.
7. American Concrete Institute. ACI 440: State-of-the-Art Report on Fiber Reinforced Plastic (FPR) Reinforcement for Concrete Structures. Farmington Hills, MI, 1993.
8. Makizumi, Sakamoto, and Okada. "Control of Cracking Using Carbon Fiber Net in Reinforced Concrete," ACI SP-138: Fiber Reinforced Plastic Reinforcement for Concrete Structures, 1993.
9. Toray Industries, Inc. "Toray - Torayca Quality Carbon Fiber," Torayca Technical Reference Manual, 1998.
10. Personal communication with Toray Industries, Inc., 22 January 1999.
11. Personal communication with Zoltek Industries, Inc., 22 January 1999.

## **SECTION 8 DURABILITY OF FRP-REINFORCED LIGHTWEIGHT CONCRETE MARINE STRUCTURES**

### **8.1 DURABILITY DESIGN OF MARINE STRUCTURE**

Durability of a structure has been defined as the ability of the structure to continue performing its design functions in a satisfactory manner over its design life. Modern concrete structures are generally built for a design life of 50 to 100 years. For port, bridge, and tunnel structures, a 75- to 125-year design life is now being adopted. However, concrete structures do not experience an inherent life cycle of satisfactory service followed by sudden disintegration. Loss of durability is generally gradual, but often progresses exponentially with time, requiring steadily increasing maintenance and repair.

Loss of durability has been a major economic problem in waterfront infrastructures due to their direct exposure to the severely aggressive environment. Marine structures are vulnerable to various physical and chemical degradations, including corrosion, sulfate attack, delayed ettringite formation (DEF), significant daily temperature and moisture variation, impact and abrasion; and for floating structures in locations of significant wave exposure, high magnitude cyclic loading. These deleterious processes often act synergistically to impose an increasingly aggressive attack on marine structures.

In belated recognition of the enormous expenses incurred in maintaining our rapidly aging waterfront infrastructure, today's engineering design places greater emphasis on durability. In simple terms, design for durability means to take extra measures to secure long-term satisfactory performance of the structures during their service life. Needless to say, some of these measures will directly or indirectly increase initial investment expenditures. Justification for the initial investment in durability lies in the economical potential to offset any future expenditure for maintaining the structures throughout their service life. Therefore, the basic economics of durability design can be represented as follows.

<b>Durability Investment Should Be Less Than The Present Value Of The Cost Of Durability Loss During Service Life</b>
---

The total cost to the owners due to loss of durability of a structure can be generally categorized into four areas:

1. Cost of repair and maintenance
2. Cost of interruption of service and utility provided by the structure for provision of repair or rehabilitation
3. Cost of obtaining access to certain repair areas that are normally inaccessible
4. Cost of demolition and replacement of the structure at the end of its service life



The maintenance and repair costs of most waterfront structures comprise several and possibly all of the items listed above. A relatively recent study on the durability of conventional marine structures shows that, on average, the present value of repair/maintenance cost for major marine structures amounts to over 40 percent of the initial investment (Refs 1 and 2). The quoted repair/maintenance cost includes only Items 1 and 3 listed above. The study is based upon a survey of several bridge and port authorities and some experts' experience. The structures surveyed in the study include coastal bridges, piers and wharves, seawater intake and distribution structures, and subsea tunnels. In other words, up to a 40 percent increase in capital expenditure on effective durability improving measures can still be economically justified on the basis of the past experience with many waterfront structures.

In practice, however, a 4 to 10 percent increase in the expenditure for durability enhancement should significantly increase the rate of return on the investment. Even a 10 percent expenditure on durability still produces a benefit-to-cost ratio of 4.

To illustrate the cost effectiveness of enhanced durability design, the following list provides durability improving measures that can be taken during construction and their cost implications. The cost increase percentage (shown in brackets) is based upon a base-case scenario in which there is no other requirement for concrete except for a minimum 28-day compressive strength and use of reinforcing steel without corrosion protection. It is noted that the cost of some durability measures is roughly proportional to the volume of the concrete, and the cost of the other measures is proportional to the surface area of the concrete. The cost estimates are "rule of thumb" numbers and are based upon concrete plate or box structures fabricated in precast yards. Costs of installation and other construction activities are not accounted for in the estimate.

1. Low water to cementitious materials (w/cm) ratios through use of HRWRA\* [1 to 2%]
2. Incorporation of fly ash and blast-furnace slag [0%]
3. Incorporation of silica fume [2 to 4%]
4. Increased concrete cover [1 to 3%]
5. Use of high-quality lightweight aggregates [2 to 3%]
6. Epoxy coating of reinforcing steel [3 to 4%]
7. Use of corrosion inhibitor [3 to 5%]
8. Cathodic protection [2 to 15%]
9. CFRP reinforcement [3 to 5%]
10. Special control of concrete production to prevent thermal cracking [0.5 to 3%]
11. Surface coating of concrete [1 to 3%]
12. Penetrating sealant [1 to 2%]

\*High range water reducing admixture (e.g., superplasticizer)

These measures apparently have substantially different effectiveness for enhancing durability performance of concrete marine structures. Past experience shows that a systematic combination of some preventive measures can synergistically achieve cost-effective improvements in durability design. A number of combinations are selected for the durability evaluation in this study. Table 8-1 shows the cost implications and expected durability of these

combinations. These evaluations are based upon our experience and judgment and should not be perceived to be conclusive.

**Table 8-1  
Cost Implications and Expected Durability of Combinations**

<b>Durability Measures</b>	<b>Cost Increase</b>	<b>Maintenance-Free Service Life</b>
Base Case	0	8 to 15 years
Options 1, 2, 4	2 to 5%	15 to 25 years
Options 1, 2, 3, 4	4 to 9%	20 to 40 years
Options 1, 2, 4, 6	5 to 9%	25 to 40 years
Options 1, 2, 3, 4, 7	6 to 9%	25 to 40 years
Options 1, 2, 3, 5, 9	8 to 14%	75 to 125 years

To ensure a 75-year, maintenance-free service life of a Navy pier, the use of composite reinforcement along with other measures is viable from both technical and economical viewpoints. A combination of the Durability Design Options 1, 2, 3, 5, and 9 results in only 8 to 14 percent cost increase from the base case, but can provide at least 75 years maintenance-free service life.

The Durability Design Options 1, 2, and 3 have been well discussed in various literatures. They are now common industry practices. Option 5, lightweight concrete, and Option 9, CFRP reinforcement, will be discussed in the following sections.

## **8.2 LIGHTWEIGHT CONCRETE TECHNOLOGY**

This section starts with a review of the performance record of lightweight aggregate concrete (LWC) in marine applications. Then, a concise summary is provided on current knowledge of the mechanical properties and durability characteristics of LWC, followed by an evaluation of potential use of LWC in floating Navy pier structures. Finally, constructability and LWC mix proportions are discussed.

### **8.2.1 Use of Lightweight Concrete in Marine Structures – Case History**

Although natural porous lightweight aggregates have been used for construction since pre-Roman times, manufactured lightweight aggregates were first produced around 1917 in Kansas City, Missouri. The impetus for making manufactured lightweight aggregates primarily came from the need to replace depleted merchant fleets and to save steel for military purposes during WWI. The feasibility study by U.S. Navy engineers at the time indicated that a concrete ship would be practical if the concrete used could have a strength over 5,000 psi (35 MPa) and a density less than 110 pcf (1.76 ton/m<sup>3</sup>). While normal weight aggregates could not meet the weight requirement, natural lightweight aggregates could not achieve the required strength. With

the assistance of the American Ship Building Authority, Stephen J. Hayde developed the first rotary-kiln production of expanded shale aggregates – “Haydite,” named after the inventor. In the following year, Haydite aggregates were used in the construction of the 300-ton (272-tonne) ship - “Atlantus.” As the record goes, Atlantus appears to be the first structural application of LWC. Since then, LWC has been increasingly used in various marine structures ranging from prestressed concrete piles to gigantic offshore concrete platforms. The long-term field experience shows that high strength LWC has an excellent record of durability, serviceability, and economy in marine environments. A few notable case histories are cited below.

**8.2.1.1 Lightweight Concrete Ships.** During World Wars I and II, no less than 40 major LWC ships were built worldwide. Tuthill gave a general review of the concrete ship construction in 1945 (Ref 3). The review documented generally favorable performance of the LWC ships. It was reported that all LWC mixes for the concrete ships generally had a 28-day strength exceeding 5,000 psi (35 MPa), and a 1-year strength in the range of 6,600 to 8,100 psi (46 to 56 MPa). As the standard practice at the time, extended water curing was practiced to improve concrete properties. A minimum of 30 days water curing was required, and whenever possible, water curing was extended until ship launching. However, none of the concrete vessels had extensive wartime service. Many were eventually used to store oil and transport cargo in the Pacific and North Sea after the wars. These vessels exhibited excellent durability. One well-documented case is an early oceangoing LWC ship named the “*USS Selma*.” The 430-foot-long, 7,500-ton (132-m, 6,800-tonne) reinforced LWC tanker was constructed in 1919, using Haydite aggregates. After many years of service, the vessel has lain partially submerged in Galveston Bay ever since. Additional history can be found at [www.buildex.com/hardite.htm](http://www.buildex.com/hardite.htm), including a photograph of the *USS Selma*. During a 1953 inspection, sections of concrete tanker were cut out above and below the mean waterline. Compressive tests of the samples showed that the average concrete strength after 34 years was 11,000 psi (77 MPa), which was more than double the reported 28-day strength of 5,600 psi (39 MPa). The bond strength with the plain reinforcing steel was 522 psi (3.6 MPa). In general, the concrete was in excellent condition even though in most places it had only 5/8-inch (16-mm) concrete cover over the reinforcing steel. It appears that the continuously moist environment and high cement content (greater than 1,100 pounds per cubic yard (650 kg/cm<sup>3</sup>) enhanced later age strength gain over its life span. According to Morgan (Ref 4), the *USS Selma* received heavy impacts during its service, but never required repair.

**8.2.1.2 Lightweight Concrete Used in Port Facilities.** Alameda Naval Air Station has a floating seaplane/boat dock that has been in operation since 1955. The floating dock consists of three large concrete barges built segmentally with normal weight concrete (NWC). A LWC deck was cast on top of the NWC units to join them into one monolithic structure. It was in continuous service for over 40 years until 1996. When inspected in the late 1980s and early 1990s, it reportedly had zero maintenance. The LWC deck showed no sign of major concrete deterioration. But there was some cracking and delamination in the outer layer of the top deck, mostly as a result of corrosion of steel inserts.

Genoa Dry Dock is a prestressed lightweight concrete floating dry dock with a total length of 1,150 feet (350 m) and a lift capacity of 110,000 tons (100,000 tonnes). Built in 1971 in Italy, the dock consists of prestressed lightweight concrete walls and slabs with internal space trusses of steel members. The LWC mix consisted of 759 pounds per yard<sup>3</sup> (450 kg/m<sup>3</sup>) sand, 1,332 pounds per yard<sup>3</sup> (790 kg/m<sup>3</sup>) expanded clay lightweight aggregates, and 674 pounds per yard<sup>3</sup>

(400 kg/m<sup>3</sup>) blast furnace slag cement. The concrete reached a compressive strength of 6,500 psi (45 MPa) and an elastic modulus of 3,000 ksi (21 GPa) in 56 days. Inspection reports from Lloyds Registry and from Italy indicate that the concrete hull is in good condition today.

**8.2.1.3 Lightweight Concrete Used in Offshore Structures.** Arctic structures represent one of the early major applications of LWC in offshore structures. Typical examples of such structures are the Glomar Beaufort Sea 1 (Super CIDS) and Tarsuit. Super CIDS is a mobile exploratory oil drilling structure that can be ballasted to sit on the sea floor and then deballasted and moved, and yet has the structural strength and stability to resist multiyear ice floes. The Super CIDS structure consists of a steel mud base, a 233-foot (71-m) square, 44-foot (13.4-m) tall LWC cellular midsection, and a modular steel topside. The structure is designed to resist the impact of a 25-foot (7.6-m) thick, multiyear ice floe moving at 2 knots (1.0 m/s) velocity.

Three general types of concrete mixes were used in the Super CIDS construction: (1) sand LWC with 10 percent fly ash was used for the bottom and top slabs and concrete internal cells (silos), the design strength (at 56 days) and the actual strengths were 6,500 psi (45 MPa) and 9,000 psi (62 MPa), respectively; (2) sand LWC with 10 percent silica fume was used for the external walls, the design strength (at 56 days) and the actual strengths were 6,500 psi (45 MPa) and 9,000 psi (62 MPa), respectively; and (3) NWC with 10 percent fly ash was used for the internal shear walls, the design strengths (at 56 days) and the actual strengths were 8,000 psi (55 MPa) and 11,000 psi (76 MPa), respectively.

The LWC used Mesalite expanded shale aggregates with a partially sealed surface. All the concrete mixes had a very low water to cementitious materials (w/cm) ratio (0.29 to 0.32). Special emphasis was placed upon the quality control procedures to produce consistent high-quality concrete. In order to prevent freeze/thaw problems that were expected in the Arctic environment, the absorption of Mesalite aggregates was predetermined to avoid absorbing too much water into the lightweight aggregate. The aggregates were stored in an "oven dry" condition and an additional 4 percent of water was added to the mixer to compensate for the initial absorption of the Mesalite. The concrete was delivered to the forms by bucket so that any potential problems associated with forcing mix water into the lightweight aggregate as a result of pumping was eliminated.

Super CIDS was initially installed in the Beaufort Sea, Alaska, in August 1984. It was decommissioned in 1986 and recommissioned for offshore drilling in 1987. Since 1993, it has been used as an offshore station at the Arctic Natural Wildlife Refuge. Although the structure has been exposed to the severe Arctic and offshore environments since 1984, numerous inspections over the years showed no apparent damage due to its exposure to freeze-thaw, ice impact and abrasion, and extreme temperature variation in the Arctic environment. To this date, Super CIDS has not undergone any major repair or rehabilitation.

As the offshore industry has gone through a learning curve and gained confidence in the use of lightweight concrete technology, LWC is increasingly being used in multibillion-dollar projects, such as construction of the Troll, Heidrun, and Hibernia offshore oil production platforms. These gigantic LWC structures, displacing up to 800,000 tons (726,000 tonnes) and standing over 984 feet (300 m) in the sea, are designed to withstand thousands of cycles of large open ocean waves and violent wind gusts. In some cases, the structures are designed to resist impact loads from icebergs weighing millions of tons. Both the gravity-based Troll platform and the tension leg platform Heidrun use LWC for their main shafts with design strengths in the

range of 9,400 to 10,200 psi (65 to 70 MPa). These Grade 70 LWC mixes had an exceptionally high workability and were pumped to heights exceeding 650 feet (200 m).

The Hibernia gravity-based concrete platform was initially designed with NWC. A design problem with launching draft from the dry dock forced a design change to use LWC. To increase the buoyancy of the structure, its shafts and domes were consequently constructed with semi-lightweight concrete. About 50 percent of the normal weight aggregates in the original design mix were replaced with Stalite expanded shale aggregates, resulting in a 10 percent reduction in weight. The semi-LWC attained 11,600 psi (80 MPa) compressive strength in 56 days and met all the constructability requirements for massive, continuous, and long-distance pumping, and the durability requirement for the severe freeze-thaw environment.

Hibernia also highlighted some of the problems of working with LWC. Slipforming of the concrete was difficult and resulted in defective concrete in the ice zone that was eventually repaired.

It should be emphasized that the excellent performance of the structural LWC in all the major marine projects described above can only be achieved through use of high-quality constituent materials, careful attention to the mix design, and a high degree of quality control during production.

A number of different brand name lightweight aggregates is discussed here. Each has somewhat different properties, different costs, and different availability. The costs and availability of particular lightweight aggregates change over time. Thus the production LWC mix design will be adjusted to allow use of LWC aggregates that are both economically viable and available at the time of construction.

## **8.2.2 Microstructure Characteristics: LWC versus NWC**

The internal microstructure of LWC is primarily credited for its superior performance in marine environments. The microstructure of LWC is distinguished from that of NWC in two fundamental aspects: (1) the inherent bonding strength between aggregates and cement paste matrix, and (2) compatibility of elastic moduli of aggregates and cement paste matrix.

**8.2.2.1 Lightweight Concrete Bond in the Transition Zone.** In general, concrete may be considered as a two-phase material consisting of coarse aggregates and a cement paste matrix. The cement paste matrix is essentially made of cement, water, and sand. In NWC, the contact surface between the coarse aggregates and cement paste matrix, often referred to as the "transition zone," is the weakest area in the matrix. The weak transition zone is mainly caused by trapped water and air under the coarse aggregates during placement, creating local areas of porous cement hydrates with high water-to-cement ratio. Furthermore, because there is no chemical reaction between natural aggregates and cement, the bonding between the aggregates and paste matrix solely depends on mechanical interlock.

Lightweight aggregates for structural uses are mostly made of expanded clays, shales, or slates. The pozzolanic substances in these aggregates are reactive with the lime in the cement paste, forming a stronger bond strength in the transition zone. In addition, the porous structure of lightweight aggregates tends to absorb water from the paste around the aggregates, resulting in the beneficial effects of lower w/cm ratios in the transition zone. Micrographic examination of LWC shows that its transition zone is much denser and there is an absence of microcracks that are commonly observed in the transition zone of NWC.

**8.2.2.2 Lightweight Concrete Deformation Compatibility.** The distribution of internal stresses in loaded concrete is highly influenced by the deformation compatibility of its aggregates and cement paste matrix. Normal weight aggregates are generally much stiffer than the cement paste matrix. The elastic modulus of limestone aggregates, for example, is within the range of  $4.4\text{-}14.5 \times 10^6$  psi (30 to 100 GPa), while the elastic modulus of high strength cement paste matrix is typically  $2.0\text{-}2.9 \times 10^6$  psi (14 to 20 GPa). Under external loads or thermal stress, the incompatibility in deformation of the two materials tends to create higher stress concentrations at the aggregate-matrix interface. These stress concentrations further degrade the bond strength and initiate cracking in the transition zone.

In comparison to NWC, the stiffness of lightweight aggregates is much more compatible with the surrounding cement paste matrix. Lightweight aggregates usually have elastic moduli in the range of  $1.5\text{-}2.3 \times 10^6$  psi (10 to 14 GPa). Thus, the elastic modulus of lightweight aggregates is on the same order of magnitude as that of the cement paste matrix. The deformation compatibility of the two materials results in more uniform stress distribution within the LWC and, consequently, substantially less internal microcracking under all types of loads.

### 8.2.3 Mechanical Properties of LWC

**8.2.3.1. Lightweight Concrete Compressive Strength and the Strength-to-Weight Ratio.** The compressive strength of LWC is inherently lower than that of NWC with similar mix proportions, because lightweight aggregates are more porous and typically of lower strength than normal weight aggregates. However, it has been common to produce Grade 35 to 50 LWC (5,000 to 7,000 psi [35 to 50 MPa]) in major civil projects. For major offshore concrete platforms, such as Hibernia and Troll, the 28-day compressive strength of the LWC reached 10,000 psi (70 MPa) or greater. High-strength LWC can be achieved by a combination of several cost-effective methods, including: (1) reduction of w/cm ratio; (2) use of silica fume or other pozzolanic materials; (3) use of high-quality lightweight aggregates; (4) use of special lightweight aggregates, such as Microlite; and (5) replacing lightweight fine aggregates with natural sand. Most importantly, LWC has excellent strength-to-weight ratios. Studies show that LWC has an average strength-to-weight ratio of 35 kPa per  $\text{kg/m}^3$  while the average strength-to-weight ratio of NWC is about 27.

**8.2.3.2 Lightweight Concrete Tensile Strength.** Tests show that the tensile strength of LWC tends to be the same as or slightly higher than that of NWC for the same compressive strength. Both direct tensile strength and modulus of rupture may be related to  $\sqrt{f'_c}$ ; ( $f'_c$  = compressive strength of concrete). For calculation of deflection, ACI 318 code requires a tensile strength reduction factor of 0.85 for sand-lightweight concrete and 0.75 for all-lightweight concrete when using the ACI formula to determine tensile strength as a function of compressive strength. However, the actual relationship is very complex. The appropriate way to determine the tensile strength is to conduct strength tests on actual concrete cylinders, and not solely rely on the formulas given in the codes.

**8.2.3.3 Lightweight Concrete Shear Strength.** At working stress levels, the shear strength of LWC is about the same as that of NWC. But at ultimate strength, the shear strength of LWC is generally lower than that of NWC. This fact is related to the notion that aggregate

interlock in LWC is substantially less. Most codes of practice require a reduction in the allowable shear stress of 20 to 25 percent. ACI 318 code requires a reduction factor of 0.85 for sand-lightweight concrete and 0.75 for all-lightweight concrete. We believe that the code provision for the design shear strength reduction is prudent.

**8.2.3.4 Lightweight Concrete Bond Strength.** The bond strength of LWC to plain round steel bars is approximately the same as that of NWC. For deformed bars, tests at service load levels show that LWC containing silica fume has a significantly higher bond strength than NWC at working stress levels. As the slip between concrete and reinforcement increases, the bond strength depends on the mechanical interlock between the ribs and aggregates. Therefore, NWC has greater bond strength than that of LWC at ultimate strength levels. ACI 318 code requires a 30 percent increase in development length for steel reinforcing bars embedded in LWC. Bond strength between FRP and LWC is governed by different mechanisms and parameters than that of steel reinforcement. Special studies are required to determine the appropriate development length of FRP reinforcement.

**8.2.3.5 Lightweight Concrete Impact Resistance.** LWC has greater energy absorption upon impact than NWC, because LWC generally has higher ductility and a lower modulus of elasticity. If well confined, lightweight concrete can sustain 6 to 10 percent axial compressive strain without loss of strength. In-service experience with both LWC and NWC showed different behavior under similar impact loads. NWC showed a small damaged area on the surface, but the internal damage was extensive. Observation and post-damage investigation of impact damage in LWC structures, such as the Tarsuit Caisson Retained Island, indicate that impact damage exhibited larger areas of concrete flaking on the surface, but the internal damage was minimal. Repairs of Tarsuit were easily accomplished and the structural integrity was not compromised.

**8.2.3.6 Lightweight Concrete Abrasion Resistance.** Laboratory testing indicates that abrasion resistance of concrete is highly dependent on the concrete strength and hardness of aggregates. On the basis of early test data, both ACI Committee 357 report "Guide for the Design and Construction of Fixed Offshore Concrete Structures," and FIP "Recommendations for the Design and Construction of Concrete Sea Structures," (Ref 11) include the requirements that concrete subjected to abrasion should contain hard coarse aggregates and the fine aggregate content of the mix should be kept as low as possible. However, in practice, over 20 years of field experience with Arctic structures shows that high-strength LWC has excellent resistance to ice abrasion. Special abrasion resistant coatings were also found to be effective in mitigating abrasion damage.

As part of the BERGER/ABAM joint industry program to develop lightweight concrete suited for Arctic application, a series of ice abrasion tests were performed. During the three phases of this test program, five different methods of evaluating the ice abrasion resistance of the lightweight concrete mixes were developed. As no standard method exists for the evaluation of abrasion by ice, four different techniques were tried along with one standard abrasion test for comparison purposes.

Testing was conducted in both the United States and Japan. Four different lightweight mixes were evaluated. From this series of tests, the mixes were ranked in terms of their relative resistance to ice abrasion.

In addition to the ice abrasion tests, the adfreeze bond behavior of the mixes was determined. This parameter is important in areas of substantial ice coverage because the possibility exists that substantial amounts of ice, under pressure from surrounding large ice features, can remain in contact with a concrete structure for substantial periods of time. Under some temperature conditions, this ice can freeze directly on the concrete surface or become "adfrozen." When the surrounding ice begins to move, a bond shear force develops at the concrete/ice interface. Over a sufficiently large ice/structure contact area, significant global loads from this ice bonding may develop. To examine whether this was a real concern, a special test method was developed to determine the limiting force magnitudes that could be developed in this way.

**8.2.3.7 Lightweight Concrete Cyclic Fatigue Strength.** Fatigue failure of concrete can be a problem in floating marine structures subjected to significant levels of global tension as a result of wave loading. LWC generally provides better resistance to cyclic deterioration than NWC. The better fatigue resistance of LWC results from the deformation compatibility between aggregates and cement paste matrix. Thus, microcracking in LWC is reduced under repeated cyclic loads and internal stresses are more uniformly distributed. In comparison, NWC has higher stress concentrations at the interface between aggregates and cement paste, leading to earlier formation of fatigue microcracks in the transition zone. In addition, cement and pozzolanic materials are reactive to lightweight aggregates, which helps improve the bond in their transition zone and results in fewer microcracks. Tests show that LWC containing pozzolanic materials increases fatigue strength by 30 percent over those of NWC with the same mix proportion.

**8.2.3.8 Lightweight Concrete Creep and Shrinkage.** Creep and shrinkage of concrete are mainly results of water migration due to imposed stress and evaporation, respectively. They are related to many interrelated factors, such as water content, coarse aggregate content, voids structure, and environmental humidity. In the past, however, there are reported cases that prestressed LWC members experience more creep and shrinkage (10 to 20 percent) than those of NWC members, resulting in higher prestress loss and potentially larger long-term deflection than anticipated. This potential for larger creep deflections must be accounted for in design. It has been found that replacing lightweight fine aggregates with natural sand can significantly reduce creep. Use of high-quality lightweight aggregates also substantially reduces creep. The creep of structural LWC is approximately proportional to the ratio of applied stress to the strength at the time of prestressing. Significant creep of precast LWC can generally be avoided by specifying sufficiently high levels of concrete strength at the time of prestressing. Past experiences also show that proper concrete mix design and adequate design allowance for creep and shrinkage potential should generally eliminate any problems associated with creep and shrinkage of LWC.

**8.2.3.9 Effect of Fine Aggregates Used in Lightweight Concrete.** For structural lightweight concrete, it has been common practice to replace lightweight fine aggregates with normal weight sand. This is in part because the weight of LWC is mainly affected by its coarse aggregates. Sand-lightweight concrete has substantial advantages over all-lightweight concrete, including an increase in compressive strength and bond strength, improvement in workability, and considerable reduction in creep and shrinkage of the concrete.



## 8.2.4 Durability Characteristics of LWC

Marine concrete structures are subjected to various chemical and mechanical attacks throughout their service life. Concrete deterioration in the splash zone at and near the waterline is often caused by a combination of several deterioration mechanisms, both environmental and physical. In general, high-quality LWC is highly resistant to chemical attacks and volumetric deformation, because high-quality lightweight aggregates consist of chemically and thermally stable minerals. The minimal internal microcracking of LWC and the closed void structures of lightweight aggregates further reduce permeability to deleterious materials.

In the past three decades or so, extensive tests have been carried out to investigate the durability characteristics of LWC. Investigations on early LWC structures, such as the *USS Selma*, were also conducted to verify accelerated laboratory test results. The following sections summarize the conclusions of these durability studies.

**8.2.4.1 Lightweight Concrete Permeability.** Permeability limitation is the most fundamental parameter against chemical and physical deterioration, such as corrosion, freeze-thaw damage, sulfate attack, and delayed ettringite formation (DEF). It is primarily a function of the microcracks and pore structures in concrete. These microcracks and voids form channels for water to migrate in, out, and through the concrete. In general, permeability of concrete is primarily controlled by its w/cm ratio, effectiveness of compaction (consolidation), and curing. But the internal structure of lightweight aggregates also has a direct effect on permeability. If the voids inside lightweight aggregates are interconnected, LWC will be very permeable. High-quality lightweight aggregates have their internal voids well separated so that the porosity of the aggregates does not affect overall permeability. For example, Carolina Solite has only 3.5 percent absorption after being fully immersed for 24 hours. Taisei's Bilton N lightweight aggregate has almost zero absorption. Because LWC does not have the same degree of microcracking and debonding in the transition zone as found in NWC, permeability of LWC using high-quality aggregates tends to be lower. Extensive tests have confirmed that high-strength LWC containing silica fume and/or fly ash has an extremely low permeability.

**8.2.4.2 Lightweight Concrete Freeze-Thaw Durability.** Freeze-thaw damage of concrete is primarily caused by expansion of freezing water in the voids and microcracks of concrete. The expansion forces may stress the cement hydration gel beyond its tensile strength, resulting in permanent damage. When there are air voids for the freezing water to expand into, the expansion pressure is released. The amount of moisture in the concrete and degree of saturation of the aggregates influence freeze-thaw resistance of LWC. Some expanded shale or clay aggregates remain 50 to 80 percent unsaturated even after 100 days of immersion. Studies show that the freeze-thaw durability of presoaked saturated lightweight aggregate concrete is not significantly different from that of NWC. Air-entrained LWC made with air-dry lightweight aggregates shows a significant improvement in freeze-thaw durability over similar NWC. This improvement is primarily due to the low permeability and increased air voids in the LWC aggregates. High-strength LWC has shown remarkable resistance to freeze-thaw damage in many marine structures in Arctic environments.

**8.2.4.3 Lightweight Concrete Alkali-Aggregate Reaction.** Although there is a potential for detrimental alkali-aggregate reaction with some natural lightweight aggregates, lightweight

aggregates for structural concrete are manufactured from expanded shale, clay, and slate. These manufactured aggregates are pozzolanic and, in fact, inhibit any alkali-silica reaction. There is no known instance of in-service distress due to alkali reaction with lightweight aggregates.

**8.2.4.4 Sulfate Attack of Lightweight Concrete.** Sulfate attack on concrete is basically a result of chemical reactions between sulfate ions, lime, and alumina hydrates. The reactions convert the alumina hydrates into ettringite that expands and exerts pressure onto the surrounding concrete. The expansion of ettringite can cause cracking and strength reduction in concrete. In principle, aggregates do not affect ettringite formation. The best protection against sulfate attack is good quality concrete with low permeability that prevents penetration of sulfates into the concrete.

Although lightweight aggregates by themselves do not increase or decrease the risk of sulfate attack, the low permeability of high-strength LWC can substantially increase the resistance to sulfate attack. Also, proper use of pozzolanic materials in LWC can be very beneficial in preventing sulfate attack by reducing the permeability and the amount of alumina hydrates formed.

**8.2.4.5 Delayed Ettringite Formation (DEF) in Lightweight Concrete.** Recent studies show that ettringite formation can develop over a long period of time even without ingress of external sulfates. DEF-related damage has been observed in waterfront structures, such as cracks in some prestressed concrete piles on the California coast and the Pacific Northwest coast. Although the mechanism of DEF has not yet been well understood, it appears that DEF is closely related to three elements: (a) extensive microcracking, (b) exposure to water, and (c) later age sulfate release from certain types of cement. Without any one of these three elements, DEF cannot take place. As discussed above, LWC minimizes the occurrence of microcracking. Proper uses of pozzolanic materials and cement with lower sulfate content also help to prevent DEF. Thus, proper mix design and selection of LWC materials will minimize the risk of DEF-related damage. Control of concrete curing temperatures to below certain threshold values also appears to reduce the tendency for DEF-related damage.

**8.2.4.6 Lightweight Concrete Fire Resistance.** LWC is highly fire resistant mainly because of: (1) its chemical stability, (2) reduced thermal expansion, and (3) lower thermal conductivity. Most natural aggregates become chemically unstable at around 500°C (870°F). Because structural lightweight aggregates (expanded shale and clay) are exposed to high temperature in excess of 1,100°C (2,000°F) during the manufacturing process, they are inherently more stable than normal weight aggregates at very high temperatures. As a result, structural LWC experiences less reduction in strength at high temperatures. Secondly, the thermal expansion coefficient of LWC is about 50 percent less than that of NWC. Thus, LWC experiences much less thermal expansion and develops lower thermal stresses for a given temperature gradient. Furthermore, the thermal conductivity of LWC is over 50 percent less than that of NWC. Lower thermal conductivity increases the time for LWC members to reach steady state temperature. This often results in lower internal temperature gradients under transient external high temperature conditions and, therefore, less potential for thermally induced concrete spalling.

Furthermore, concrete exposed to fire will spall in thin layers as a result of internal vapor pressure (steam) as water evaporates from the concrete. If the coarse aggregates in LWC contain

more isolated air voids and less water, the spalling damage will be less than that of NWC. To mitigate or eliminate the potential for steam vapor build-up and explosive spalling, it is preferable to use lightweight aggregates with lower absorption. Examples of low-absorptive aggregates include Carolina Solite (3.5 percent at 24 hours immersion), Mesalite (4.5 percent at 24 hours immersion), and Taisei's coated Bilton N (near zero absorption).

Polypropylene fibers have been successfully used in concrete to prevent steam vapor spalling from exposure to fire. Polypropylene will melt under moderately high temperatures prior to development of vapor pressure, creating numerous interconnected channels inside the concrete. When high vapor pressure develops, these channels function as a pressure-relieving system to allow rapid dissipation of the steam from the concrete without the spalling of the concrete cover. In some critical structural components that could be exposed to fires, such as the working and utility decks, use of polypropylene fibers will be further considered in the final concrete mix design.

### **8.2.5 Evaluation of LWC Applications in Floating Structures**

The excellent long-term field experience in aggressive marine environments and numerous beneficial characteristics of LWC make it a superior material for floating Navy piers. The main advantages of LWC in this application can be summarized as follows:

- LWC has a very good service record in numerous reinforced concrete ships for over 80 years (Refs 3 to 7). Field experience shows that, if properly engineered and constructed, LWC can significantly improve serviceability and durability over conventional NWC.
- LWC inherently has a higher strength-to-weight ratio than that of NWC. For the same buoyancy, LWC floating structures can have significantly higher load-bearing capacity than NWC floating structures.
- LWC is more uniformly stressed under external loads due to deformation compatibility and a strong bond between the aggregates and cement paste matrix. As a result, LWC has fewer internal microcracks than NWC for the same external loading. The reduced microcracking equates to reduced potential for deterioration of all types.
- LWC has about 50 percent lower thermal expansion. Thus, it experiences lower thermal stresses than NWC. Lower thermal stresses lead to less tendency to crack and spall as a result of these stresses.
- LWC has higher ductility and energy absorption capacity than NWC. Thus, impact damage to LWC tends to be less severe. It also provides more load redistribution in an indeterminate structure in case of accidental overloading.
- LWC generally provides better resistance to fatigue deterioration under repeated loads than NWC. High-quality LWC shows about a 30 percent increase in fatigue strength over NWC.

- High-strength LWC containing good quality aggregates and proper pozzolanic materials has lower permeability than NWC, because of stronger matrix/aggregate bond and less microcracks in the transition zone.
- When construction procedures to limit the amount of water absorbed by the lightweight aggregate are adopted, high-strength LWC has improved durability over NWC when exposed to freeze-thaw environments.
- Manufactured lightweight aggregates are not susceptible to detrimental alkali-silica reaction. There is no known instance of in-service distress due to alkali reaction with lightweight aggregates.
- LWC is less susceptible to sulfate attack than NWC, because LWC is generally less permeable to ingress of sulfate ions.
- LWC is highly fire resistant mainly because manufactured lightweight aggregates are chemically stable under high temperature conditions, and LWC has lower thermal expansion and lower thermal conductivity than NWC.

LWC structures have their own special requirements and implications in both design and construction. Attention should be paid to the shear design, as the shear strength of LWC can be substantially lower than that of NWC. Long-term creep could cause unanticipated prestress loss and camber if no precaution is taken in structural design, concrete mix design, and construction procedure. Due to the tendency of lightweight aggregates to absorb varying amounts of mix water depending on the degree of saturation at the time of batching, special efforts and careful quality control are required in the production of LWC in order to maintain consistent workability, w/cm ratio, and strength of the concrete throughout the construction process. Special construction requirements are discussed in Section 8.2.6.

At present, the cost of high-quality LWC constituent materials is approximately 10 to 15 percent more than that of NWC. This cost increase in LWC materials usually amounts to only a 2 to 3 percent increase in the construction cost of the prestressed/precast components. In terms of total project cost for a Navy pier, this cost increase becomes less than 1 percent.

The above cost comparison is made on a "per unit volume" basis. In general, LWC has a higher strength-to-weight ratio than NWC. In actual design, a LWC floating pier may cost less than its NWC counterpart due to the substantial reduction in weight and buoyancy required. In fact, modern design of long-span bridges and offshore concrete platforms has already taken advantage of LWC's strength-to-weight ratio for economy.

In summary, the excellent characteristics of LWC in aggressive environments outweigh the difficulties associated with its special design requirements and special construction requirements. High-quality LWC is a generally preferable material to NWC in construction of floating Navy piers.

## 8.2.6 LWC Mix Proportions

With the advances in concrete and construction technologies and with prestressing techniques, LWC floating structures have become viable both from technical and economic viewpoints. Nevertheless, LWC has its special constructability issues.

The first issue results from the weight of the aggregates. Because the aggregates are lighter than the other components of fresh concrete, aggregates tend to float up under intensive vibratory compaction. Overworking the surface while finishing the concrete can cause the same problem by bringing an excessive amount of coarse aggregate up to the surface. To prevent this problem, LWC should have sufficient cohesion. A common practice is to limit LWC to 4-inch (100-mm) slump.

The second issue results from the weight of the concrete itself. Due to the low weight of the concrete, a normal amount of vibratory compaction may not create adequate internal shear stresses necessary to make the concrete flow and compact. Thus, some LWC mixes that show an apparently high workability when mixed manually do not compact as readily as expected in actual mass production. On the other hand, over-compaction may correct this problem, but cause segregation as discussed in the above.

The third issue results from the porous nature of the aggregates. Some lightweight aggregates are very absorptive of the mixing water in cement paste. A minor change in the moisture content of lightweight aggregates can substantially affect the concrete workability. It requires special effort to maintain a consistent w/cm ratio and a workable slump from batch-to-batch and in day-to-day operations.

Pumping of LWC presents another issue. When pumped under pressure, some aggregates can absorb water from the fresh concrete mix, causing rapid slump loss.

Our engineering practice has shown that these constructability issues can be solved effectively with proper concrete mix design and proper construction practices. The criteria for proportioning LWC mixes are high workability, high resistance to segregation, reliable water retention during mixing and pumping, consistent w/cm ratio, low permeability, and uniform strength of concrete from different batches.

Concrete mixture proportioning is essentially a trial-and-error optimization process. The process should be guided by a set of governing variables and an understanding of how each variable affects the concrete. As a starting point, we propose an LWC mix that has been extensively tested in a Joint Industry Study (Ref 8, Table 8-2) as the base case concrete mix for trial batch testing of LWC.

A proper dosage of air entraining admixture will be added to the concrete. The use of air entrainment will improve air void distribution in the concrete, i.e., smaller air voids at closer spacing. The smaller more distributed air void system lowers the permeability and enhances the durability of the concrete. Furthermore, air entrainment also significantly enhances the workability of the concrete.

**Table 8-2  
LWC Mix Proportions**

Components	Proportions (per cubic yard)
Cement (Type I/II)	752 lb (341 kg)
Silica Fume	45 lb (20 kg)
Lightweight Coarse Aggregates (Solite)	1,067 lb (presaturated) (484 kg)
Natural Silica Sand	934 lb (424 kg)
Water (excluding absorption of aggregates)	255 lb (16 kg)
Plasticizer and Superplasticizer	Adequate dosage to produce 4 inches (100 mm)
Air Entrainment	Adequate to produce 4% air entrainment
Measured Average 28-Day Cylinder Strength	9,900 psi (68 MPa)

The proposed floating Navy pier requires the use of CFRP mesh or closely spaced CFRP bars for crack control and impact resistance. It will be increasingly difficult to perform adequate internal vibratory compaction. To develop the optimum concrete mix for the Navy pier, emphasis should be placed upon such concrete characteristics as flowability and self-compaction. A "superworkable" lightweight concrete mix will be desirable for which internal compaction is not required and finishing can be kept to a minimum. Therefore, the above base case LWC mix will be modified to achieve these objectives. Specifically, a higher dosage of superplasticizer will be used to produce flowable concrete. Special viscosity agents (such as SIKA's Viscocrete and/or Sikament 100SC) will be used to avoid segregation.

It is recommended that trial batching tests of LWC be conducted in Phase 2 of this research program. At this point, we suggest a set of performance criteria for the LWC mix in the floating pier as shown in Table 8-3.

**Table 8-3  
Test Protocol and Performance Requirements**

Test Item	Standard Test Method	Standard Mixture Performance Requirements
Slump tests after mixing	ASTM C 143	Slump = 11" $\pm$ 1/2" (279 $\pm$ 13 mm)
Slump flow after mixing	None	Slump flow > 11-1/2" (292 mm)
Slump tests at 60 minutes after mixing	ASTM C 143	Slump at 60 minutes > 5" (125 mm)
Test of the time of setting	ASTM C 403	Initial set time > 4 hours Initial set time < 10 hours Final set time < 14 hours
Compressive strength at 3 days, 7 days, 14 days, 28 days, 56 days, 90 days	ASTM C 39	Average 56-day compressive cylinder strength > 8,900 psi (61 Mpa)
Splitting tensile strength at 3 days, 7 days, 14 days, 28 days, 56 days, and 90 days	ASTM C 496	
Elastic modulus and Poisson's ratio	ASTM C 469	
Creep of concrete in compression	ASTM C 512	
Permeability of concrete	ASTM C 1202	< 2,000 coulombs
Bleeding test	ASTM C 232, method A	Bleed water < 2.0%

### 8.2.7 Use of Fly Ash in LWC Mixes

This project is an excellent candidate for using cement mixtures that include fly ash. Benefits of using high volume fly ash (HVFA) mixtures for the hybrid pier include:

- Reduction in capital cost and total life-cycle cost
- Extended long-term durability
- More environmentally friendly

Use of fly ash, or pulverized fuel ash (PFA), as a cement replacement in concrete has been heavily promoted by the American Concrete Institute (ACI). PFA cement replacements have been demonstrated and used in many commercial applications. Very high amounts (over 50 percent) of PFA have been successfully used in Canada for more than 20 years. In the United States, ACI Committee 211 limits cement replacement to less than 25 percent for Class F fly ash and to 35 percent to Class C fly ash. Conventional replacements are typically closer to 15 and 20 percent, respectively.

Waterfront structures are excellent candidates for using mixtures containing high PFA in applications that can tolerate slower strength gain during construction (strength gain criteria may need to be increased to 60 days rather than the conventional 28 days). Also, these structures often contain thick cross sections that are prone to cracking from the exothermic reaction associated with cement hydration, which is compounded by mixes involving high quantities of Portland cement. At early ages, PFA concretes have a reduced temperature rise that can have a significant advantage for large concrete masses. Fly ash is a finely divided pozzolan, and fine pozzolans in the presence of moisture react with the calcium hydroxide at ambient temperature to improve the long-term ultimate strength of concrete. Ordinary Portland cement concrete mixtures that contain conventional dosages (5 to 15 percent) of Type C fly ash will result in lower permeability concrete, which in turn will result in better protection of the steel reinforcement in the presence of chlorides. In some states, the use of PFA is required for highway concrete for its resistance to sulfate attack and corrosive salts. For equal water-cement ratios, the addition of PFA also improves workability and pumpability. For a given workability, the bleeding is also reduced. Large Arctic offshore concrete structures containing PFA have proven successful. Finally, PFA will tend to mitigate any alkali-silica reaction (ASR) from reactive aggregates.

Cement is the most expensive constituent of concrete before adding forming and placement costs. A cubic yard of 5,000-psi (34-MPA) ready-mix concrete costs \$68.25 (for Los Angeles, ENR 5 October 1998). Up to \$21, or 30 percent, of the cost is due to the cement itself. Hence replacement of 30 to 50 percent of the cement by fly ash can result in total concrete material savings from 9 to 15 percent, or 2 to 3 percent of the in-place concrete cost. Improved concrete quality will also result in improved durability that will reduce maintenance costs and increase performance life.

Experts on global warming link 7 percent of the world's carbon dioxide (CO<sub>2</sub>) emissions to the procurement of Portland cement, a main concrete component. In the United States, cement production accounts for about 2.4 percent of total industrial and energy-related CO<sub>2</sub> emissions. By significantly decreasing the amount of total cement used in construction, the Navy would be

able to reduce cement consumption and the associated CO<sub>2</sub> emission. Because concrete is a major building material, the economic and environmental savings can be substantial.

Using high PFA contents will result in: (1) savings in Portland cement production, (2) enhanced durability in a marine environment, (3) higher PFA recycling, (4) reduction in CO<sub>2</sub> generation, and (5) conformity with affirmative, environmentally responsible procurement regulations and Department of Defense affirmative procurement policy.

### **8.3 DURABILITY OF CFRP MATERIALS**

In general, CFRP is a very durable material in high alkali environments, such as concrete. Neither strength degradation nor other deterioration processes have been reported in CFRP embedded in concrete or immersed in seawater. The corrosion resistant nature of CFRP makes it the ideal material for reinforcement in concrete marine structures. Several noteworthy durability issues are discussed below.

#### **8.3.1 Fatigue Strength of CFRP**

Like steel and concrete, CFRP is subject to fatigue degradation to a certain extent. Under repeated loading, CFRP will develop cracks within the resin matrix and at the interface between fibers and resin. The fatigue damage of CFRP materials typically appears in the form of a reduction in stiffness. Stiffness-based fatigue diagrams (S-logN curves) have been established for some CFRP materials. In the initial designs using CFRP, the design criteria will be to keep stresses in the CFRP below the endurance limit in those areas subject to high cycle fatigue loading.

In structural elements subject to fatigue loading, special consideration will be given to the appropriate fatigue stress level allowed in the CFRP material.

#### **8.3.2 Creep Rupture of CFRP**

A rupture failure of composite materials under sustained tension loading is recognized as creep rupture or "static fatigue." It is generally accepted that CFRP does not experience creep rupture under sustained load less than 50 to 60 percent of the short-term strength.

#### **8.3.3 Creep and Relaxation of CFRP**

Properly designed CFRP does not exhibit significant creep nor relaxation under long-term sustained loads less than 50 percent of the short-term strength. Bond creep of CFRP is less than bond creep of steel. Research has shown that creep of reinforced concrete members is predominantly controlled by creep of the concrete.

#### **8.3.4 Temperature Effects of CFRP**

Steel and concrete have about the same coefficient of thermal expansion ( $\sim 12 \times 10^{-6} / ^\circ\text{C}$ ). CFRP materials, on the other hand, have a coefficient of thermal expansion of  $0.5\text{-}1.5 \times 10^{-6} / ^\circ\text{C}$ . Therefore, thermal stresses in CFRP reinforced concrete members will vary with seasonal or



even daily temperature changes. Research conducted in Japan and Europe show that the seasonal temperature variation alone is not significant enough to cause concrete cracking due to volume changes.

### **8.3.5 Galvanic Corrosion of CFRP**

When two materials with different electrical potential are in contact, there is a possibility of galvanic corrosion in one of the materials. When CFRP bars and tendons are in contact with steel, the risk and degree of corrosion of steel is not well understood. It is generally believed that the resin material on the outside of the carbon fibers provides high electrical resistance and prevents galvanic electrical currents between the two materials. Therefore, galvanic corrosion will not take place in such a condition. If CFRP is damaged, however, then the corrosion potential of the steel in contact with it is unknown. It is advisable that CFRP not be in direct contact with steel.

## **8.4 REFERENCES**

1. Gerwick, B.C., Cusens, A., Lacroix, R. "The Technical Review Committee Report on Durability of Concrete Liners in Eurotunnel," 1990.
2. Gerwick, B.C. "Economical Aspects of Durability," P.K. Mehta Symposium, Nice, France, 1994.
3. Tuthill, L.H. "Concrete Operations in the Concrete Ship Program," Journal of the American Concrete Institute, Vol. 16, No. 3, 1945.
4. Gerwick, B.C. "Report of the FIP Commission on Prestressed Lightweight Concrete," FIP Publication, 1966.
5. Gerwick, B.C., editor. "Concrete Ships and Floating Structures," Proceedings at University of California, Berkeley, 1975.
6. ABAM Engineers, Inc. "Feasibility and Practical Limits for the Use of Lightweight Prestressed Concrete as a Shipbuilding Material," Technical Report, NTIS No. AD-A122 954/1, 1982.
7. ABAM Engineers, Inc., etc. "Developmental Design and Testing of High-Strength Lightweight Concretes for Marine Arctic Structures," Joint Industry Study AOGA Project No. 198, 1983.
8. Ben C. Gerwick, Inc. "Peripheral Concrete Wall Design Study, Phase II and III," Joint Industry Study, AOGA No. 324 and No. 359, 1987.

9. Wetmore, S.B. "The Concrete Island Drilling System: Super Series (Super CIDS)," OTC 4801, Proceedings of the 16<sup>th</sup> Annual Offshore Technology Conference, Houston, TX, May 7-9, 1984.
10. LaFraugh, R.W., Zinserling, M., McNary, J.F. "Construction and Quality assurance for Super-CIDS," Proceedings of the 4th International Symposium on Offshore Mechanics and Arctic Engineering (OMAE), Dallas, TX, February 1985.
11. Fédération Internationale de la Précontrainte. FIP/6/1: "Recommendations for the Design and Construction of Concrete Sea Structures," Third Edition, July 1977.
12. American Concrete Institute. ACI 357: State-of-the-Art Report on Barge-Like Concrete Structures, 1988.

## **SECTION 9 CONCEPT DESIGN CONFIGURATION TO MEET OPERATIONAL GOALS**

The purpose of this section is to evaluate the extent that the recommended floating pier concept meets the operational goals outlined in the solicitation for this program.

The following are the operational goals listed in the original solicitation for this project and commentary on how the goal is met.

### **9.1 VESSELS SERVED**

The length of the pier has been set to provide four berths, two per side. Length of the structure has been set to accommodate the ships to be berthed (CGs, DDGs, and FFGs) per the provisions of DM 1025.1 (see Section 7.1.2). The mooring system and ship service utilities will be designed to accommodate vessels berthed two abreast.

### **9.2 OPERATIONAL SPACE**

The operational space provided on the working deck was developed using information provided in User's Guide UG-0007: Advanced Pier Concepts, prepared by NCEL and BERGER/ABAM experience with both military and commercial pier design. This amounted to setting the width of the working deck 90 feet (27.4 m) between curbs (see Section 7.1.3). The width of the utility deck was developed to allow small vehicle access and areas for utility line routing.

### **9.3 MODULARITY**

Modularity is provided by the floating pier concept at the facility level. It will also be possible to design the individual pier modules (250 to 500 feet [76 to 152 m] long) as elements that could be used as stand-alone facilities. The desirability of doing this will be further explored in Phase 2. Utility subsystems will be designed in easy to install, maintain, and replace modules.

### **9.4 PREFABRICATION**

The floating pier concept is conceived as a totally off-site prefabricated facility. Additionally, we envision most of the structural elements that comprise the floating pier to be fabricated as precast concrete elements. Utility systems and secondary structural features will be prefabricated to the greatest extent possible.

Preliminary mooring concepts have been developed that directly support the efficient off-site prefabrication and timely installation of the facility at the final deployment site (see Section 11).

## **9.5 MAINTENANCE-FREE SERVICE**

The proposed combination of prestressed lightweight concrete (see Section 8) in combination with CFRP mesh reinforcing used in accordance with the proposed design criteria and methodology will provide a maintenance-free hull with a life in excess of 75 years. Utility systems will be designed with a primary focus on maintainability, detailed consideration of utility systems, and secondary structural features will take place in Phase 2.

## **9.6 COMPETITIVE COST**

We are of the opinion that the proposed floating pier concept will offer the Navy the most overall value for the dollars spent. See Sections 6.4 and 15 for further discussions of costs.

## **9.7 STATE-OF-THE-ART OPERATION**

The configuration of the floating pier and its systems will be developed in further detail in Phase 2. DM 1025.1 and the experience of the team members will be used to perform the initial refinement of the operational configuration of the pier. Once this has been preliminarily developed, we are proposing an Operational Peer Review Workshop to review each of the operational features of the proposed concept and take maximum advantage of lessons learned by various operational entities.

In addition to the traditional berthing support activities, the floating pier has internal space available to house and support a range of activities from crew amenities to light industrial shops.

## **9.8 UNLIMITED CRANE ACCESS**

To achieve this objective, the working deck is configured and designed to allow placement of the design crane outriggers anywhere on the deck (see Section 7.2.1). The access ramp to the working deck will be designed to allow transit of a 140-ton (1,245-kN) truck crane.

## **9.9 FUNCTIONAL SEPARATION OF DECK OPERATIONS AND UTILITIES**

The floating pier concept is a double-deck concept that separates the working deck operations from the utility deck operations. In addition to providing physical separation of utilities and associated lines, hoses, and cables from the working deck area, the double-deck provides expanded ship service capability. With a double-deck pier, there is double the amount of the most valuable deck space along the perimeter of the pier as compared to a single-deck pier. This is a very significant feature.

## **9.10 STATE-OF-THE-ART MATERIALS USE**

In addition to the state-of-the-art materials used in the primary structure of the pier, FRP systems, products, and features will be used to the practical maximum to take advantage of their low-maintenance characteristics. The design team will continue the dialog begun with the Composites Institute and individual FRP product suppliers to assure that this takes place. The preliminary design activity will identify all of the secondary structure and features where FRP will be used.

## **9.11 INTERFACE WITH NAVY-PROVIDED FENDER SYSTEM DESIGNS**

The Navy is currently involved in a fender system development program. It is proposed that in the future preliminary design effort we will develop the interface between the Navy provided fender system and the floating pier structure.

## **9.12 EFFORT TO LEAD TO A 2004 MILCON PROJECT**

The structural configuration selected and the materials selected for use in the design were chosen with due consideration that the objective is to construct a full-sized functional berthing pier facility based on the results of this program as part of the MILCON 2004 construction program. The planning design and development tasks necessary can all be performed to meet the 2004 construction project time line if continuing progress is made.

## **9.13 UTILITIES**

The floating pier concept causes the least disruption to naval operations in the area of the project. The structure is completed and outfitted off site and towed to the final deployment site. The only remaining operations to be performed on site are connections to the land-based utilities and to the mooring system(s) and some equipment checkout. Other benefits to this type of structure are the ability to use below deck space (hull compartments) to accommodate operations activities, and the ability to relocate the structure if required.

### **9.13.1 Utility Layouts**

One of the major issues facing NAVFAC (and commercial facilities) is the functional obsolescence of facilities. During a 75-year life, the pier will have served several generations of Navy vessels. With each generational change in vessels, new and improved utilities and subsystems are typically required. (The vessel is designed around the latest technologies, not what is available for ship service support at existing NAVFAC shore facilities.) Retrofitting an existing pier to accommodate the latest generation surface combatant (and existing vessels) can range from difficult to cost prohibitive; hence, many piers need to be replaced in order to accommodate the new vessels (missions). Similarly, as vessel types are redeployed within the

fleet, vessels different from those the pier was originally configured to accommodate may be assigned to berth at the pier.

One of the goals of this study is to provide a pier configuration that allows for easy access to utilities and subsystems so that they can be replaced, repaired, and reconfigured more easily. The layout of a double-deck pier provides greater opportunity to retrofit or upgrade these systems rather than replace a pier to accommodate the requirements of the latest Navy surface combatants (missions). Use of lightweight, durable FRP products makes retrofitting in underdeck spaces and tight quarters easier. Suggested utility corridors and spaces are shown on the revised pier cross section (Drawing S-2).

Surface combatant berthing piers have been described as a means of conveying cold iron utilities to berthed vessels. The largest single item of cost, the structure, plays only a supporting role to the principal operational functions of the pier. These operational functions include fendering and mooring appurtenances, utilities services, contract training, and contract maintenance. The double-deck berthing pier concept removes the utilities services (with their tangle of electrical cables and hoses) from the operations deck. The upper deck is reserved for operations only (mooring, crew training, ship/missile maintenance, and high-mast area lighting), and the lower deck provides an out-of-the-way, organized, and dedicated location for utilities services and ships' electrical and hose hookups. All three pier concepts (conventional pile-supported, float-in modular pile-supported, and permanently floating) are configured for a double-deck arrangement. This section of the report discusses utilities for the floating concept, but with commentary relating to the modular and conventional concepts.

BERGER/ABAM participated in the value engineering (VE) review of the 35 percent design for the new 1,500-foot (457-m) Pier 2 surface combatant double-deck pier at Norfolk. We are using the Pier 2 design as an example of current state-of-the-art design for utilities. The pier can berth two nests of three DDGs each (six total) or one LHA on a side. Utilities include electrical power, sanitary sewage, oily waste (bilge water), potable and fire protection water, steam, light distillate fuel oil, JP-5 gas turbine fuel, and communications. A compressed air system was not included. Traffic lanes and parking for utilities maintenance vehicles were provided full length along both sides of the utility deck (lower deck), with a turnaround at the pier head. Clear height was set and limited by the standard maintenance truck (step van) used by Public Works Center (PWC) Norfolk. Electrical power, sanitary sewer, oily waste, and steam are the utilities that usually cause the most design problems on a berthing pier. These are discussed below.

For electrical service, DDGs require from 1,800 to 4,500 amps (480V-3P). An LHA needs 5,400 amps. The Pier 2 baseline design centralized the transformers and switchgear. There were also two stages of voltage reduction (high voltage yard distribution to medium voltage pier to 480V ship). The VE proposal broke the system down into smaller, easier-to-install and replace, more economical, and more functionally flexible units. The nested DDG requirements controlled the electrical system design. Two vaults were located at about the midpoint of each half of the pier. Each vault served both sides of the pier. Each was 40 by 60 feet (12.2 by 18.3 m) in plan, and contained four 3,750-KVA substations. Each substation comprised a 3,750-KVA transformer (single reduction directly from yard distribution voltage down to 480V), a main 5,000-amp breaker, three feeder breaker sections each with four 800 AF/400 breakers, with each of the latter serving two 400-amp receptacles located in turtlebacks of 24 receptacles each.

For the lower (utility) deck, headroom (story height), maintenance traffic lane width, and floor, live-load capacity are all limited by the initial installation and future replacement of the

transformers and switchgear. More, smaller substations (say 1,800-amp, sufficient for one DDG) may be advantageous for both cost and size. Switchgear modules are 3 feet wide by 6 feet deep by 6 feet high (0.91 m wide by 1.83 m deep by 1.83 m high). Standard transformers are 8 feet wide by 8 feet deep by 8 feet long (2.44 m wide by 2.44 m deep by 2.44 m long). Shorter, longer transformers may be available. The ideal would be to coordinate lower height maintenance vehicles (say a low-headroom propane powered tractor towing an underslung trailer) and smaller transformers so that the 7-foot (2.13-m) headroom for a walking man is the limit for utilities deck story height.

For sanitary sewage and oily waste, most berthing piers (including Pier 2) employ gravity lines from the ship hose connections to a centralized wet well, from which the fluids are pumped into force mains running to the onshore yard gravity flow system. The typical problem is that the gravity flow requires the piping to be located below the lower deck, and that the large total vertical elevation change forces the pipe below storm surge tide elevation, leading to frequent damage and repair. For the Norfolk pier, PWC experience with maintaining underpier gravity lines resulted in a net present value of future maintenance costs of about \$2 million for the two systems. The VE proposal replaced the central wet well and pumps with individual small packaged duplex FRP wet well and ejector pump modules located at several hose stations along each berth. These individually discharged into force mains running the length of the pier, which in turn discharged into the yard gravity system. This approach improved pier structure and operational flexibility, eliminated the large central wet wells, and saved \$2 million in life-cycle costs. This approach will be used on this study.

For steam lines, there are two planning issues. One is condensate return. This issue does not affect structural configuration. The other issue is steam line piping expansion. The most maintenance-free solution is the provision of expansion loops in the line, spaced say at 500 feet (152 m) on centers. The plane of the loops can be either vertical or horizontal. Neither is attractive because of the space they require. A variation is to take all the expansion by slides at the head of the pier. This is less disruptive to structural configuration. An alternative is to use high-quality, bellows-type expansion joints, which eliminates expansion loops entirely. Because neither the head slide variation or the bellows-type expansion joints materially affect structural configuration, we are assuming one or the other. The closely spaced expansion loops will not be used. Steam lines require insulation. Valves require space. Neither are serious configurational issues.

For the other liquids, there are no particularly serious configuration issues. All piping requires sectionalizing and control valves. The width required at the utilities deck level for maintenance traffic and for hookups to ships' hoses is sufficient at ceiling level to space out the piping so that gate valve bonnets can be laid horizontally and still fit between the pipes, thus not encroaching on story height. Many of the valves can be butterfly or ball type, which substantially economizes on the space required for gate valves. For this study, we will assume all piping and valves can be located overhead in the utilities story, and that the piping will be arranged to allow for the crossovers required for both electrical conduit and piping runs.

## **SECTION 10 ELEMENT DESIGN CONFIGURATIONS TO MEET STRUCTURAL REQUIREMENTS OF SELECTED CONFIGURATION**

### **10.1 GENERAL**

Once the working deck width and length are set, the deck loading criteria are developed, and the space requirements for the utility deck are defined, the remainder of the configuration of the floating pier structure is defined primarily based on structural and naval architectural requirements. The objective in the structural configuration process is to provide a configuration that directly supports the primary operational functions of the pier. Secondary functions (e.g., utility piping runs) are ideally handled as incidental load requirements on structures designed to handle the loads associated with primary function.

Once the basic configuration and structure of the pier are determined, naval architecture considerations of trim under eccentric loading, damaged stability, freeboard, and motions as a result of site wave environment are evaluated. All of these issues except motions in the design wave environment have been preliminarily addressed and found satisfactory for the recommended configurations shown in Drawing S-2. It is likely that for most Navy harbor wave environments, the motions of this pier will be small and acceptable. The detailed response to waves is something that should be evaluated in detail against the range of wave environments likely at prospective deployment sites for the new pier facilities. This is an activity that should be performed in Phase 2.

### **10.2 HYDROSTATICS**

During the configuration of the floating pier in Phase 1, the hull depth was increased from the initial configuration to 28 feet (8.54 m) at the center, a 2-foot (0.61-m) increase over the original starting draft. One foot (0.30 m) of the increase was due to increased draft as a result of member design and 1 foot (0.30 m) of the increase was due to providing a 2 percent cross slope on the top deck, for proper drainage. The current floating pier drafts are 10 feet (3.05 m) in light ship condition and 13 feet (3.96 m) in loaded condition.

A preliminary estimate of the hydrostatic characteristics of the floating pier is presented in Appendix D. The revised cross section shown in Drawing S-2 was used and a tabulation of approximate quantities of materials is provided. The tabulation is incomplete in that estimates of equipment weight have been made without benefit of an actual design. It is not anticipated that weights of mechanical and electrical systems will noticeably affect the hydrostatic properties of the floating pier.

### **10.3 TYPICAL CONSTRUCTION DETAILS**

Typical construction details were developed for a precast construction method similar to that used to construct the Valdez Floating Dock. It is generally believed that if the structure can be designed for precast construction that it can then be easily converted to an all cast-in-place construction should a contractor desire to construct it in this manner.



Precast construction consists of precasting as many elements as possible in a factory-type operation, usually in a horizontal (flat) position. These elements are then erected, connections between elements are completed, and the joints cast-in-place. Major elements of construction are:

- Precast Wall Segments with Cast-in-Place Joints
- Cast-in-Place Keel Slab
- Precast Deck Panels/Stay-in-Place Forms
- Cast-in-Place Deck Topping

Typical construction details are shown in Figures 10-1 through 10-3. Figure 10-1 is a section through the keel at midspan. The keel is a cast-in-place element. The prestress tendons are generally located in the middle of the section and the CFRP is located near the surfaces of the element. Figure 10-2 shows a typical joint detail at the bottom of an interior wall at the intersection with the keel slab. The wall is precast. Keel slab reinforcing and tendon ducts are spliced with projecting elements from the precast wall and the keel is then cast-in-place. Figure 10-3 shows a typical joint detail at the top of an interior wall at the intersection with the top deck or an intermediate deck. The top of the precast wall is flared out to provide a ledge/corbel to set the precast deck panels on. The precast deck panels serve as stay-in-place forms, as well as structural elements. Prestress tendons are placed on top of the precast panels, CFRP reinforcing is placed near the top surface and the topping is then cast-in-place.

#### **10.4 ELEMENT CONCRETE OUTLINES**

Variable thickness (haunched) slabs are commonly used as structural elements in floating concrete structures. This provides extra thickness at the supports, where the bending stresses are greatest. The haunched shape also tends to increase the ratio of support moment to midspan moment, increasing the portion of the total static moment resisted by the stronger cross section near the support. Furthermore, the use of the haunched shape permits straight (or almost straight) prestressing tendons to be on the tension side of the concrete section, both at midspan and at the support (see Figure 10-4).

Haunched slabs are normally constructed using straight tapers for the haunch. However, when using the carbon mesh for reinforcement, it may be better to use a curved shape, so that the carbon mesh may be elastically bent to a longer radius curve to avoid locking in high stresses in the CFRP.

Fillets at the corners of the intersecting plates are useful. They increase the effective depth and lever arm for flexural stresses that must flow around the corner. The fillets can also reduce the critical moment near the support by causing the critical section to occur at the end of the fillet, where the negative moment is reduced somewhat.

#### **10.5 CARBON MESH REINFORCING USE**

A few comments on mesh element spacing, or pitch, are in order. The carbon mesh used for reinforcing is assumed to be composed of individual elements spaced at 1 inch (25 mm) in

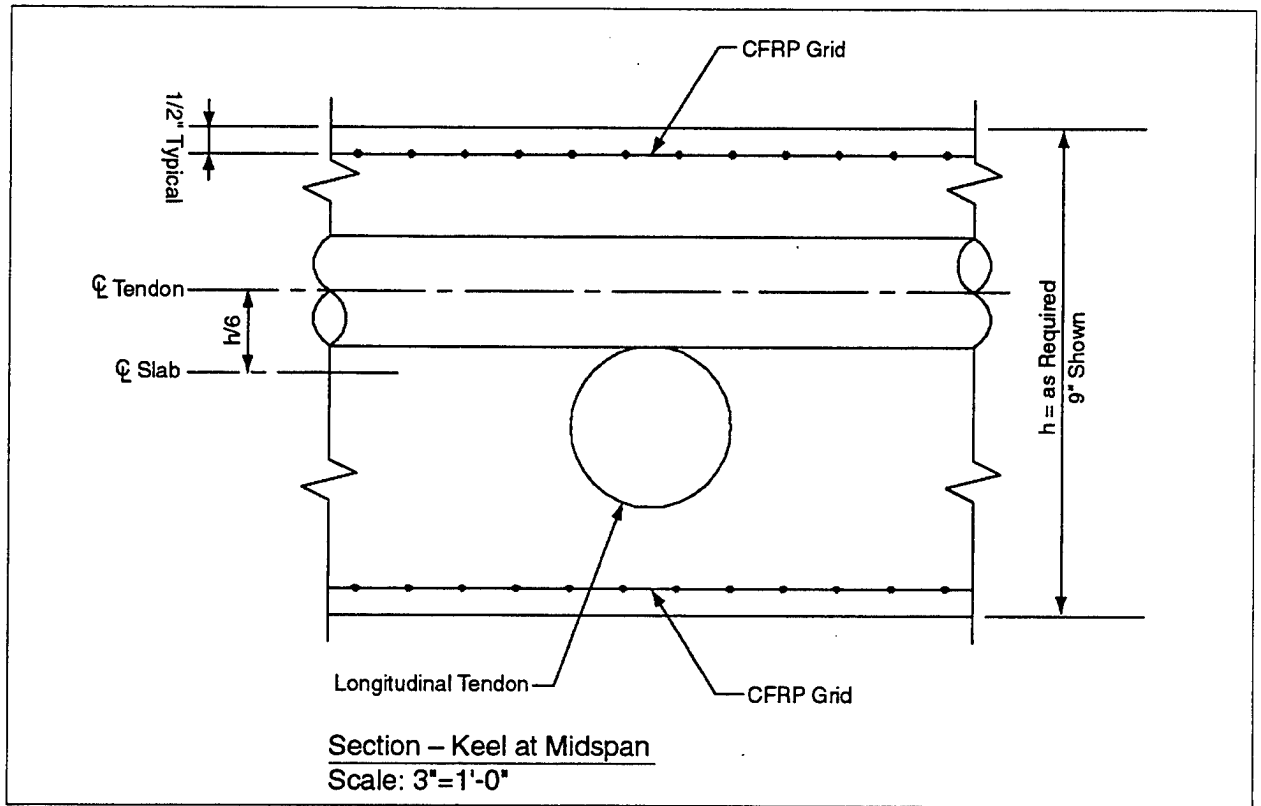
each direction. Each element can vary from 1/16 to 1/8 inch (1.5 to 3 mm) in diameter, with an area of approximately 0.003 to 0.010 square inch (2 to 6.5 mm<sup>2</sup>). The elements are not necessarily round; a flattened shape approximately 1/16 by 1/4 inch (1.5 by 6 mm) may be more appropriate. The epoxy impregnated material may be delivered to the construction site much like welded wire fabric - in sheets about 8 feet (2.4 m) wide, with long lengths in a coil 5 to 8 feet (1.5 to 2.4 m) in diameter. The sheets would be cut to the desired length at the job site with a special cutting tool that cuts the entire width at once. The sheets are very light, weighing about 0.2 psf (1 kg/m<sup>2</sup>).

The spacing between elements is somewhat arbitrary and needs to be refined in future phases. ACI 318 suggests that aggregate size not exceed 3/4 of the clear space between reinforcement (e.g., carbon fiber elements). For a 1-inch (25-mm) pitch (in each direction) and 1/8-inch (3-mm) diameter element, this would result in a maximum aggregate size of  $(1 - 1/8) \times 3/4 = 0.66$  or 5/8 inch (16 mm). Typical aggregate sizes for high-strength concrete will normally be in the range of 1/2 to 5/8 inch (12 to 16 mm). Hence, 1-inch (25-mm) pitch in the CFRP mesh appears to be acceptable. If the pitch becomes too tight, the grid will act as a screen to segregate the coarse aggregate, which then can result in laminar planes of weakness, especially in flatwork (e.g., thin slabs). As part of the Phase 1A testing, the potential for development of a weakened plane at the level of the CFRP grid reinforcing will be evaluated. Grids in both the 1-inch (25-mm) range and 2-inch (50-mm) range will be evaluated. Note that the 1-inch (25-mm) grid pitch is too fine for inserting pencil vibrators, and hence a high flowability and self-compacting concrete mix is a necessity for grid spacing in this range.

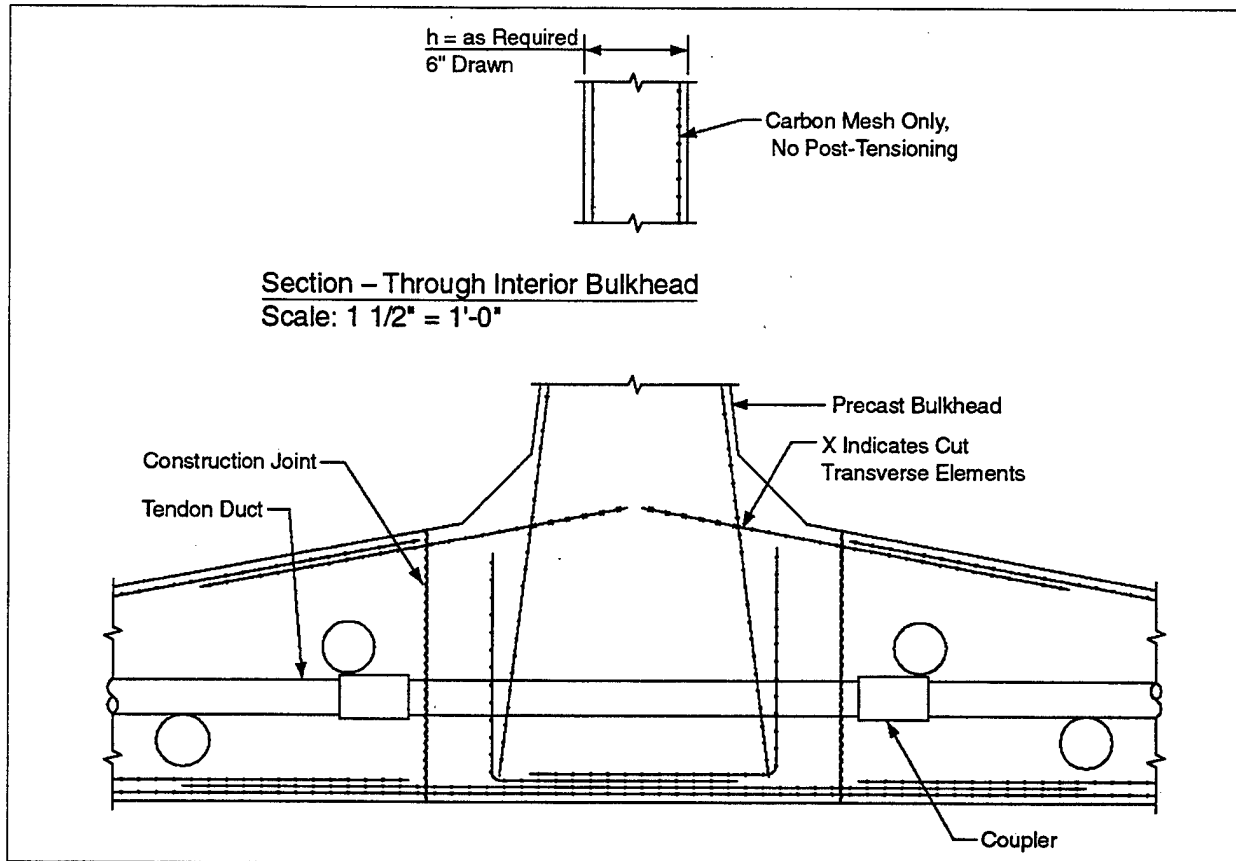
A useful special tool or machine for working with CFRP mesh would be one that cuts the transverse elements of the mesh, so that short lengths of the longitudinal elements can be passed through an intersecting sheet (see Figure 10-5). This will be especially useful for obtaining anchorage at inside corners. This machine would preferably do all cuts needed without resetting the grid on the machine.

An important characteristic of the mesh will be the number of "welded" cross member intersections needed to develop the strength of a longitudinal element. This will determine required lap lengths. The strength of the "welded" intersection will be highly dependent on the manufacturing process, and will have to be determined by tests on samples embedded in concrete.

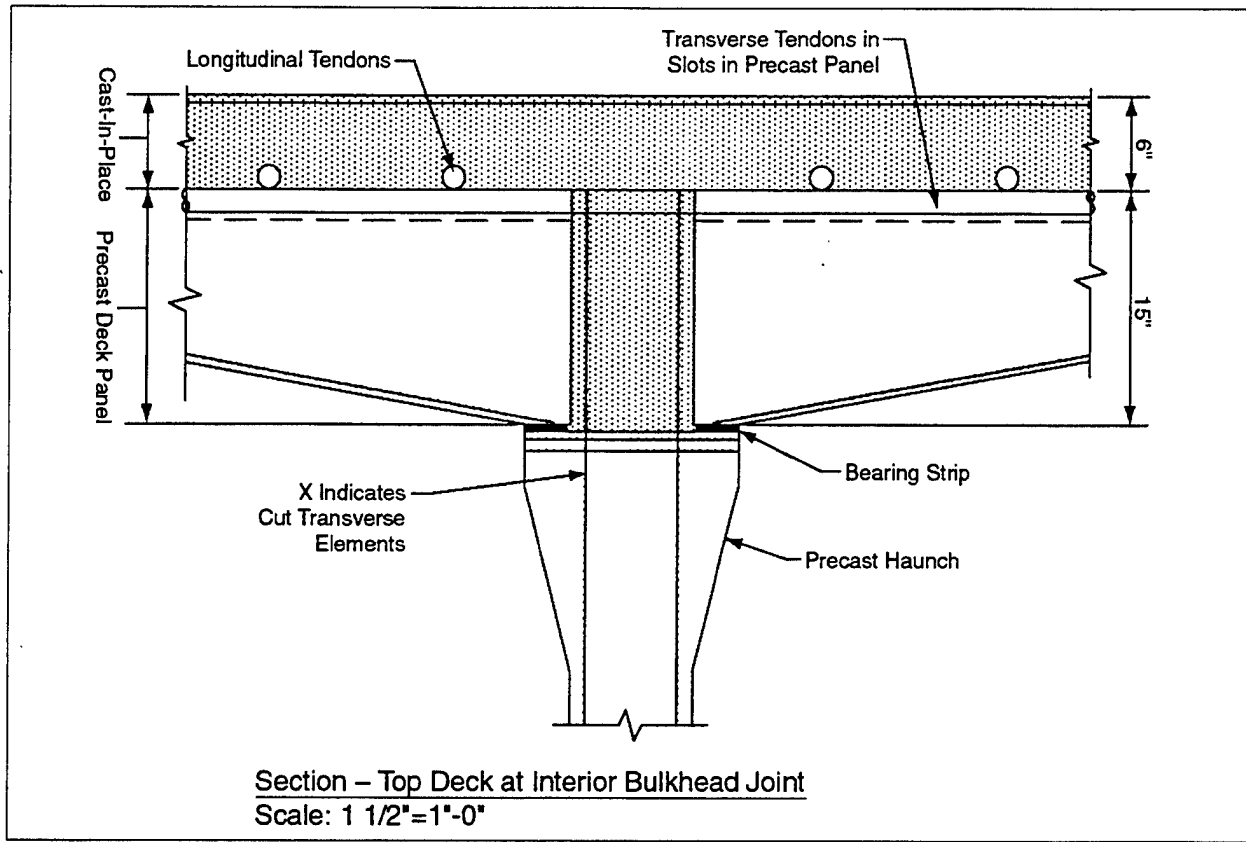
Once the resin surrounding the fibers has cured, the elements or mesh cannot be bent in the same manner as steel bars or steel fabric. It is very costly to have sheets custom bent at the factory (prior to curing of the resin) for each location in the structure. Instead, standard prebent shapes in the form of an L and U should be used at corners in the structure, and lapped with flat sheets in the slabs and walls (see Figure 10-6). A possible alternative to prebent shapes may be to use prepreg material and a field impregnator to produce composite material that can then be shaped as needed before the resin cures. This type of operation is used to fabricate composites in the aircraft industry and to repair concrete with CFRP sheets.



**Figure 10-1**  
**Section – Keel at Midspan**

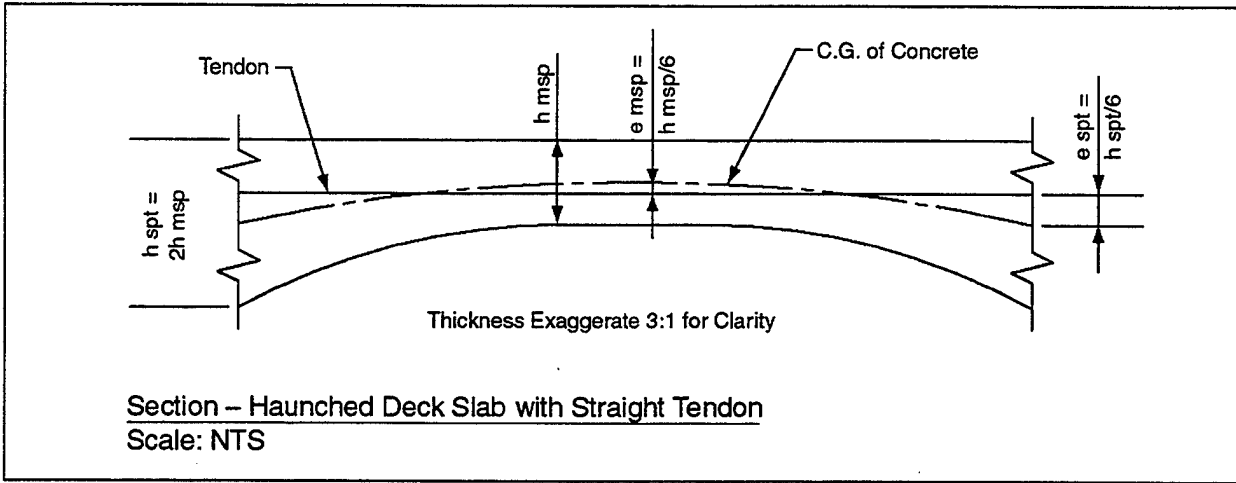


**Figure 10-2**  
**Section – Keel at Interior Bulkhead Joint**

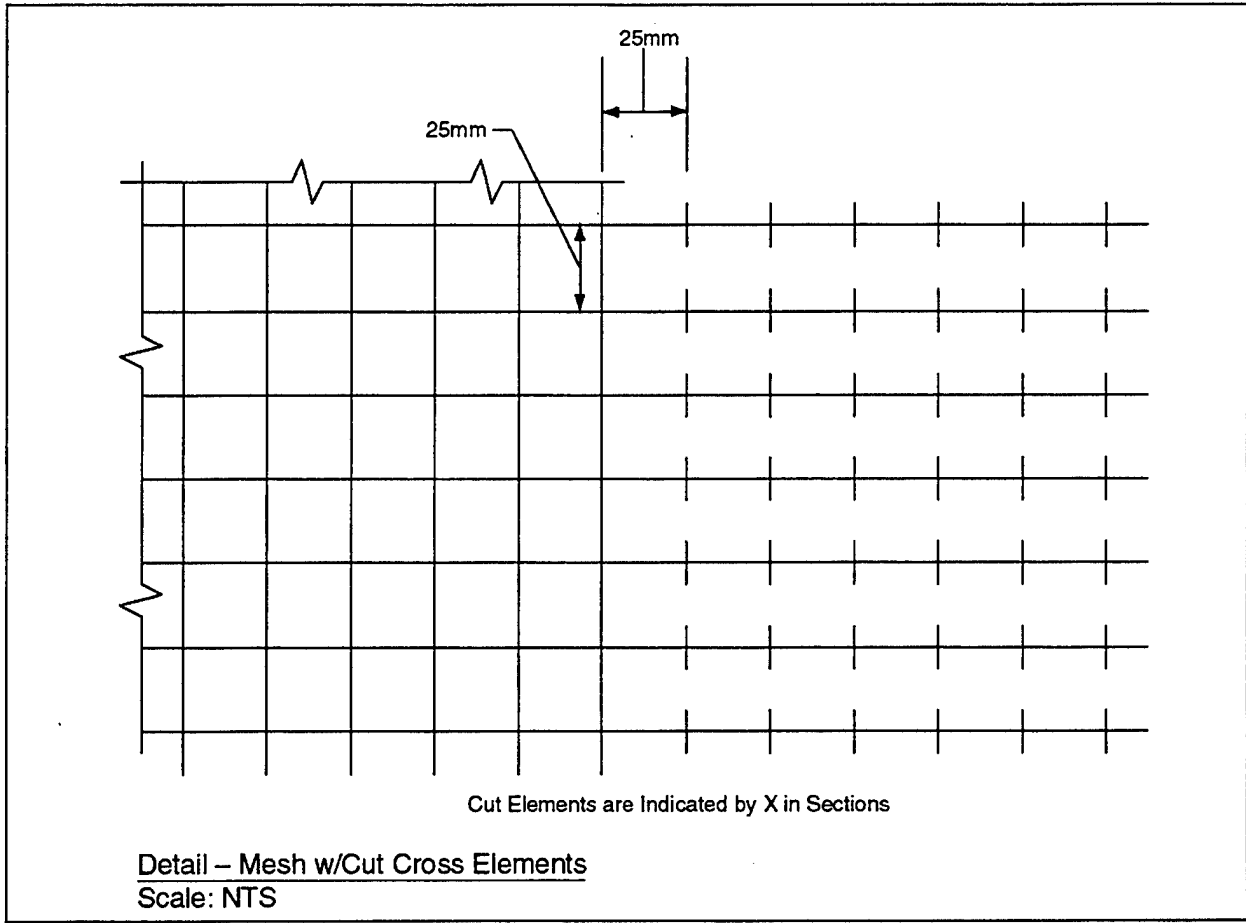


**Figure 10-3**  
**Section - Top Deck at Interior Bulkhead Joint**

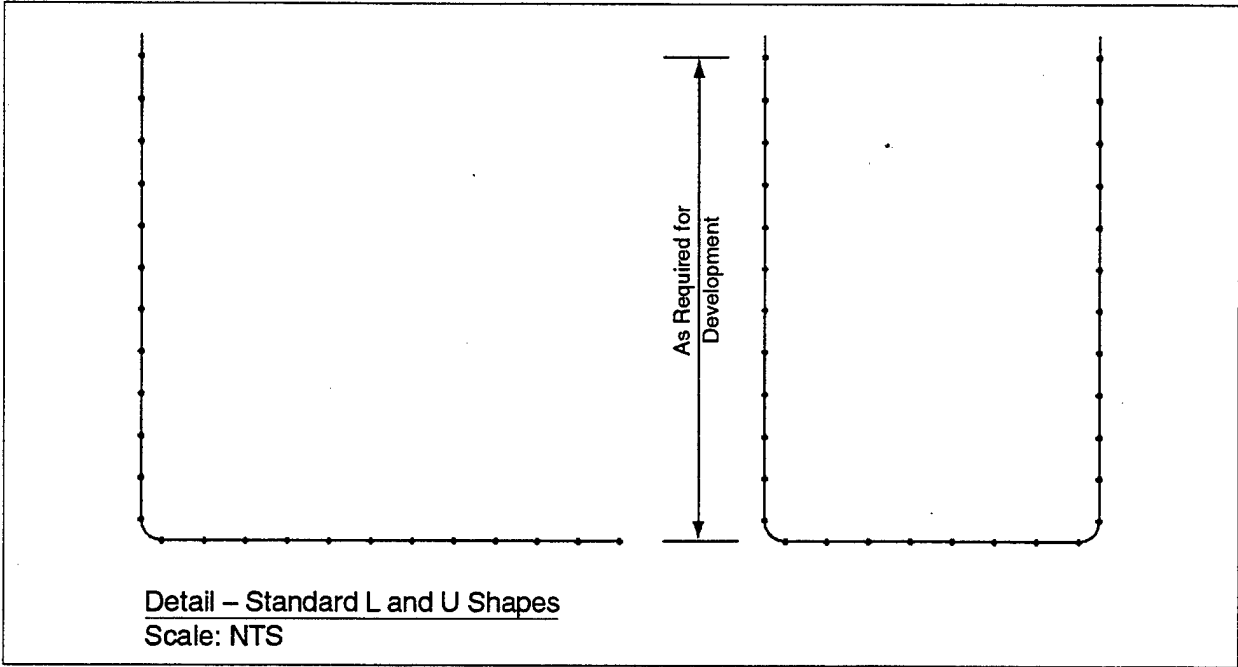
**Note: This detail is for a minimum thickness deck.  
 A thicker deck would be easier to detail.**



**Figure 10-4**  
**Section – Haunched Deck Slab with Straight Tendon**



**Figure 10-5**  
**Detail - Mesh with Cut Cross Elements**



**Figure 10-6**  
**Detail - Standard L and U Shapes**



## **10.6 KEEL PLATING CONSTRUCTION**

The keel plating is often constructed as a cast-in-place element using the floor of a dry dock for the exterior form surface. In a precast floating dock system, the cast-in-place keel plate is used to integrate the vertical precast wall elements with the bottom plate and with each other. The bottom plate is a primary watertight element and a primary structural member for longitudinal and transverse global bending. Typically the keel plating is prestressed in both the longitudinal and the transverse direction. It will be reinforced with two layers of CFRP mesh located near the interior and exterior surfaces of the plate. Typically the keel plate receives only hydrostatic loading, unless the interior of the pier is used for some operational purpose.

## **10.7 EXTERIOR WALL PLATING**

The exterior wall plating is often constructed as full height precast panels. The lower edge of the panel will usually include the corner detailing and extend beyond the corner somewhat so that the connection between the wall plate and the keel plate is relatively simple. Anchors for the transverse post-tensioning of the deck plate keel plate are often cast into the precast wall plate. The exterior wall plating receives both hydrostatic loading and fender reaction loads. The wall plates are primary structural members for carrying global shear associated with wave and still-water bending. Typically exterior wall plates are prestressed in both the longitudinal and the vertical directions. Longitudinal prestressing is typically accomplished using strand tendons while prestressing in the short vertical direction is best handled by some type of bar prestressing. It will be reinforced with two layers of CFRP mesh located near the interior and exterior surfaces of the plate. If precast, these plates would likely be cast as flat panels.

## **10.8 INTERIOR WALL PLATING**

The interior wall plating typically receives only local shears from concentrated deck loads or global bending shear. These elements are designed for damaged condition hydrostatic loads. Typically these elements are prestressed in the longitudinal direction only with prestressing located in the center of the panel. It will be reinforced with two layers of CFRP mesh located near the interior and exterior surfaces of the plate. If precast, these plates would likely be cast as flat panels.

## **10.9 WORKING DECK**

The working deck design is predominated by the requirement to resist the high concentrated loads from the crane outrigger. This element also acts as primary structure for global longitudinal bending. It is typically prestressed in both the transverse and longitudinal directions. The greater thickness of the deck plate and the increased amount of reinforcement result from the design to resist the high punching shear loads. In precast designs, the top deck is typically constructed using haunched precast/prestressed deck planks that span transversely between vertical wall elements combined with a cast-in-place deck above. There will be CFRP

mesh reinforcement located near the bottom surface of the precast deck planks and located near the top surface of the cast-in-place portion of the deck pour. The post-tensioning is typically located in the cast-in-place portion of the working deck.

## **10.10 UTILITY DECK**

The utility deck will not be designed for the high concentrated loads that the working deck must carry. The construction of this deck will be similar to that of the working deck, however, the thickness will be less and the reinforcing will be less. This deck will likely be post-tensioned in the longitudinal direction only. There will be CFRP mesh reinforcement located near the bottom surface of the precast deck planks and located near the top surface of the cast-in-place portion of the deck pour. The post-tensioning is typically located in the cast-in-place portion of the working deck. This deck will include man holes to access the internal cells of the floating pier.

## **10.11 WORKING DECK SUPPORT ELEMENTS**

The working deck support elements along the longitudinal perimeter of the floating pier will either be concrete columns or intermittent wall elements. Wall elements would be similar in construction to the interior wall elements of the pier except they would not be prestressed. Columns could either be concrete filled composite shell columns or conventional concrete columns reinforced with corrosion resistant steel and carbon mesh reinforcement for stirrups.

## **10.12 ACCESS ELEMENTS**

The access ramp for the pier is an important element of a floating pier facility. Depending on the location of the pier relative to the shore, there may be a single access ramp supported at one end by an abutment located on shore and supported on the other end by a seat located on the floating pier. If the distance to the shore is long, the access may include a fixed trestle or causeway. The length of the ramp that interfaces with the pier is dependent on the amount of tidal variation and the allowable ramp slope at low and high tidal extremes. Typically the ramp slope is limited to 6 to 8 percent for the normal tidal range with slopes up to 10 percent allowed for infrequently occurring extreme tides. Thus for a 6-foot (2-m) tidal variation, the length of ramp required to limit ramp slope to 6 percent would be  $6 \text{ ft} / 0.06 = 100 \text{ feet}$  (30.4 m). For a 12-foot (3.7-m) tidal variation, the ramp length becomes 200 feet (60.8 m).

The angle change at the access ramp supports for a floating pier access ramp is larger than that common to bridge construction. Thus, special bearing details that account for the necessary angle change are necessary.

Access ramps are typically off-site prefabricated in steel so that they can efficiently be moved into position once the floating pier is in place. In some cases, it is possible and advantageous to use the approach ramp as an element of the floating dock mooring system. In these cases, the access ramp is designed to allow pretensioned mooring cables to run from the

dock through the access ramp to a dead man anchor located on shore. This approach is discussed in Section 11.8.

### **10.13 OTHER**

Other elements that are different for a floating pier than for a conventional pier include the pier-to-shore utilities interface. Because the pier is in daily motion with the tidal variations, all of the utility runs serving the pier must be designed to accommodate the angle change associated with the pier elevation change relative to shore. This means that angle change accommodating provisions in the utility lines must be provided at each end of the access ramp (assuming that the utilities are run on the access ramp).

## SECTION 11 MOORING SYSTEM CONCEPT AND CRITERIA

### 11.1 GENERAL

Floating piers require moorings to provide a lateral load resisting system. There are three basic types of mooring systems: (1) mooring dolphin/anchor pile system, (2) mooring line system, and (3) a combination of mooring line and anchor pile system. The suitability of these systems was evaluated taking into consideration tidal fluctuations, wind and current forces, clearance between mooring lines and vessels, and ease of maintenance.

In general, selection of a proper mooring system for a floating pier is not only site specific, but also dependent upon the operational and mission requirements for berthing ships. The selection of the most appropriate mooring system is primarily dependent on the water depth at the deployment site, site soils, and the wind and wave environment.

In this study, the three mooring systems have been evaluated for a "generic" case of a floating Navy pier, i.e., a 1,400-foot (427-m) long, double-deck pier for berthing of two abreast medium-size surface combatants in a 40-foot (12.2-m) water depth. For this generic case study, the investigation concludes that the mooring dolphin/anchor pile system offers the best serviceability, reliability, and economy. In cases where sufficient water depth and space for mooring lines are available, however, mooring line systems or a combination of mooring lines and anchor piles may be more advantageous. A methodology for standardizing mooring system design and mooring element selection should be more fully developed in later phases of this program.

The mooring system design assumes that the floating pier is fixed/attached to the shore for longitudinal loads (forces along the long axis of the structure). The mooring system primarily resists transverse (broadside) loading to the floating pier. It is further assumed that lateral (transverse) movement is limited, especially at the shore anchorage.

Preliminary information for sizing the mooring system for a floating pier is presented below. Two types of lateral loads are considered: berthing condition (one ship) and wind and current on the pier, and multiple moored ships. The berthing conditions generally govern the design of the fender system except in cases of extreme winds combined with large vessel sail areas, which could produce high reactions to the pier. Wind and current on multiple, moored ships will control the design of the mooring system. The calculations presented here are intended to be conservative. They will provide an order of magnitude check on the mooring system elements. Obviously, the calculations can be refined to be site specific.

Berthing energy is absorbed by the fender system, which in turn imparts a reaction to the floating pier as a concentrated load (uniform over the length of the fender element). The berthing energy absorption is actually more complex in that the mooring system also absorbs energy and hence the total reaction to the combined system will be reduced.

The wind and current produce a sustained load to the mooring system, which is transmitted through the fender system to the floating dock and then to the mooring system. The fender system does not reduce this load but rather distributes the load uniformly to the floating dock. Care should be taken in the design of the fender system that these loads do not completely compress the fender system elements.

Seismic (earthquake) loads were considered. Seismic loads are likely to have less effect on a line mooring system than on a pile mooring system.

## 11.2 VESSEL CHARACTERISTICS (Reference DM 26.6: Mooring Design – Physical and Empirical Data (Ref 1))

A review of some characteristic data for surface combatants (excerpt from Table 2 of Ref 1) is presented below:

	LOA	Displ.	Draft		Wind Area		
			ft	Long tons	Max Nav.	Light Ship	Broadside – light ship
					ft	ft	ft <sup>2</sup>
CG class <sup>1</sup>	533 ~ 547	8,250 ~ 8,750	26 ~ 30.5	12.8 ~ 15.5	22,500 ~ 23,700		
CGN class <sup>2</sup>	565 ~ 596	8,590 ~ 10,450	26 ~ 32.6	18.6 ~ 19.5	21,550 ~ 25,200		
DD963 and higher	564	7,810	30	17.7	25,850		
DDG 47, 993 and higher	568	8,910	31.6	16	28,850		
LKA/LPA/LPD/LPH	522~602	14,670 ~ 18,830	28~31	14.5~19	29,100 ~ 40,260		
Preliminary Design – Use	600	10,500 & 19,000	33	15	40,500		

**Conversion:** 1 ft = 0.305 m  
1 long ton = 1.016 tonne

**Notes:** 1 Except CG 10,11  
2 Except CGN 9  
LOA = length overall  
Displ. = displacement  
Nav. = navigation

## 11.3 CALCULATION OF BERTHING FORCES

Berthing forces can be computed using the following equation:

$$E = \frac{1}{2} * \text{Displ.} / 32.2 * V^2 * C_m * C_e * C_s * C_c = 560 \text{ ft-kips (759 kN-m)}$$

where:

E = berthing force

C<sub>m</sub> = added mass factor

C<sub>e</sub> = eccentricity factor

C<sub>s</sub> = softness factor

C<sub>c</sub> = berth configuration factor

Displ = 19,000 \* 2.240 = 42,600 kips (189.5 MN)

V = 1.0 fps (0.3 m/sec) (perpendicular to pier) velocity of vessel at berthing

C<sub>m</sub> \* C<sub>e</sub> \* C<sub>s</sub> \* C<sub>c</sub> = 0.85 (assumed)

If floating fenders are used, one 8- x 16-foot-long unit, at 60 percent compression, produces a reaction of ~ 400 kips (1,779 kN) for an energy absorption of 680 ft-kips (922 kN-m) and results in a hull pressure of ~ 3.4 ksf (162.8 kPa). Therefore, use 400-kip (1,779-kN) concentrated load for mooring system design.

## **11.4 LOADING CRITERIA FOR MOORING DESIGN**

Tables of mooring design criteria can be developed for each of the prospective sites for floating pier development. These forces are dependent on the seismic zone, design winds, wave and current environment, and type and number of vessels berthed.

### **11.4.1 Wind and Current Data**

The floating pier element should be designed for the full range of loads at all possible deployment sites. There may be significant cost advantages to tailoring the mooring system design to site-specific conditions.

For the Pacific Coast (southern California), NAVFAC DM 26.6, "Mooring Design - Physical and Empirical Data," (Ref 1) gives design wind speeds of 60 mph (88 fps [26.8 m/s]), measured at standard height. However, NAVFAC MIL-HDBK-1025/1, "Piers and Wharves," specifies that a minimum wind velocity of 70 mph (31.3 m/s) on ships be used for mooring design. Pier structures shall be designed for a minimum wind velocity of 80 mph (35.6 m/s). A design wind velocity of 80 mph (35.6 m/s) is assumed to act broadside on the berthed vessels. In higher wind conditions, it is expected that ships will put to sea.

In general, currents are negligible at most Navy berthing pier sites, except those located in rivers. Wind-induced currents, however, can be significant in certain protected areas with long fetch distances. For preliminary design, a current velocity of 2 knots (3.4 fps [1.0 m/s]) is assumed to act broadside on the berthed vessels.

Wave-induced loads on moored structures are mainly due to long-period waves and stand-off wave forces generated by passing vessels. Analytical calculations of these wave forces require site-specific evaluation and complex computer analyses. The range of wave design forces to consider will be developed in Phase 2.

In general, wave loads can be dominant for moorings sited in unprotected, high-energy environments. As the mooring site is moved into protected areas, these wave forces diminish, and the wind and current loads begin to dominate. Past experience indicates that wave forces usually do not govern the design of mooring dolphins/anchor piles in typical harbor areas. Thus, for preliminary sizing of the mooring system, only the wind and current loads are considered in the load criteria. The effects of long-period waves, stand-off wave forces, and yaw moments will be evaluated in the final design.

### **11.4.2 Water Depth**

Preliminary design of the mooring systems was based on the following water depth and floating pier draft assumptions:

Seabed	- 40 ft	(12.2 m)
Tidal range	6 ft	(0.61 m)
Light ship draft	10 ft (floating pier)	(3.1 m)
Maximum draft	13 ft (floating pier)	(4.0 m)

## 11.5 MOORING SYSTEM DESIGN LOADS

The mooring dolphin/anchor pile system is designed to accommodate four design vessels (600-foot [183-m] LOA, 15-foot [4.6-m] minimum, and 33-foot [10-m] maximum draft) at berth for a given wind velocity of 80 mph (35.6 m/s) and current speed of 3.4 fps (1.0 m per sec). Appendix E provides calculations of these load components. Combined wind and current loads produce a total lateral (transverse) reaction of 3,700 kips (16.5 MN) on the pier, which is equivalent to 2.54 kips (37.1 kN/m) per foot uniform load along the entire length of the pier. A load factor of 1.25 is applied to wind and current forces in accordance with MIL-HDBK-1025/1 to design the mooring system.

Because the ship berthing impact load is transient in nature and does not usually occur simultaneously with the maximum wind and current forces, berthing impact loads are not combined with the wind and current loads in sizing the mooring system.

Seismic loads are considered in the conceptual design. In essence, the floating pier itself is a compliant structure that attracts little seismic response. Specifically, the seismic response spectra for most earthquake-active areas, such as the southern California region, commonly have peak responses within the period of 0.2 to 1 second. The seismic responses rapidly attenuate as the period of a structure increases beyond 1 second. For a floating pier with two mooring dolphins at its ends, the fundamental period of the system is more than 4 seconds. For a floating pier with mooring lines, the fundamental period is well beyond 10 seconds. Thus, the flexible floating pier structure attracts little lateral seismic force, because its long structural period of vibration does not stimulate resonance of the ground motion.

The lateral seismic base force is calculated in accordance with the American Society of Civil Engineers (ASCE) seismic design guidelines for ports (Ref 2). In essence, building codes were originally developed for heavily occupied building structures and are not directly applicable to mostly unoccupied cargo transfer facilities. Seismic design guides for bridges are adopted in the calculation. A peak ground acceleration of 0.4g is assumed for the California region. Elastic responses of the pier are estimated on the basis of the standardized bridge design response spectral acceleration for 5 percent damping (Ref 3). In addition, a ductility and risk adjustment factor of 5 is used for the mooring dolphin structure on the basis of NFESC's recommendations (Ref 4). The hydrodynamic effects of wave forces on the pier structure during an earthquake event are accounted for in the design as an added mass. With a light ship draft at 10 feet, the added mass is calculated using Westergaard's theory as follows:

$$F_a = \gamma_w l \int_0^{10} \left( \frac{7}{8} \sqrt{10y} \right) dy = 0.0642 * 1400 * \frac{7}{12} * 10^2 = 5243 \text{ kips}$$

where:

$W_1$  (weight of the floating pier and mooring dolphins) = 94,000 kips (418.2 MN)

$W_2$  (weight of the floating pier only) = 84,500 kips (375.6 MN)

$\gamma_w$  = density of seawater

$l$  = length of the floating pier

$y$  = draft of floating pier

Thus, the added mass effect is to add about 5.6 percent weight to that of the floating pier with mooring dolphins or to add about 6.2 percent weight to that of the floating pier with mooring lines. The above calculations using the Westergaard's method basically conform to the design guidelines provided by FHWA for estimating impact loads from moving vessels (Ref 5).

The seismic base shear force can be calculated as follows:

For the pier with two mooring dolphins,  $T > 4$  seconds,  $S_a = 0.25$ , and  $W_1 = 94,000$  kips (418.2 MN)

$$V = 1.056 \frac{S_a}{Z} W_1 = 1.056 * \frac{0.25}{5} * 94000 = 4963 \text{ kips (22.1 MN)}$$

For the pier with mooring lines only,  $T > 10$  seconds,  $S_a = 0.17$ , and  $W_2 = 84,500$  kips (375.6 MN)

$$V = 1.062 \frac{S_a}{Z} W_2 = 1.062 * \frac{0.17}{5} * 84500 = 3051 \text{ kips (13.6 MN)}$$

where:

$V$  = the total design lateral force

$S_a$  = site acceleration

$Z$  = ductility and risk adjustment factor

Thus, if the floating pier is supported by two mooring dolphins, the lateral seismic base shear force has about the same order of magnitude as the factored wind and current loads. If the floating pier is anchored with mooring lines only, the seismic force will be much less than the wind and current loads. To design floating pier mooring systems in seismically active regions, site-specific seismic analysis is warranted.

## 11.6 MOORING DOLPHIN/ANCHOR PILE SYSTEM

This mooring concept consists of two pile clusters, one at each end of the floating pier, as shown in Figure 11-1. Considerations in the design include functionality, maintainability, durability, simplicity, constructability, and structural redundancy. By placing the mooring piles only at the ends of the pier, this concept circumvents a number of design difficulties and improves the efficiency of the structural system. The advantages of this concept can be summarized as follows:



- The mooring dolphin system eliminates the need for pile wells in the floating hull, thereby enhancing the structural integrity of the pier.
- The structural layout provides a simple and clear load path and, therefore, avoids uncertainties associated with complex load transfer mechanisms associated with other mooring systems.
- Because the mooring piles are located outside the pier structure, the concept avoids the complex construction logistics of installing the piles through double decks of the floating pier. This will lead to considerable cost savings and minimize the amount of overwater construction.
- One mooring pile cluster is installed prior to float-in of the pier module. The cluster can be used as the “master pile” for positioning and mooring the pier module. The second cluster is constructed after positioning the pier module. It is assumed that both pile clusters are installed by the same equipment during a fairly short construction period so as to avoid additional mobilization/demobilization costs.
- The mooring system avoids complex pile connections inside the floating hull. The mooring system-to-pier connection can be relatively simple and, hence, more reliable.
- The connections are easily accessible for inspection and maintenance.

Although not required for strength, it is recommended that one or two gravity anchors with slack chains be attached to the pier for additional redundancy in case of an accident. As an alternative, intermediate piles can be installed at the midsection of the floating pier, as shown in Figure 11-1.

### **11.6.1 Anchor Piles**

Two types of piles are considered in this study: (a) steel pipe piles, and (b) concrete filled glass fiber reinforced plastic (GFRP) pipes. While steel pipe piles can usually be installed with vibratory hammers and jetting, large diameter concrete filled composite pipes must be installed in drilled shafts. At present, the materials cost of concrete filled composite piles is similar to that of steel pipe piles with the same load-bearing capacity. But the installation cost of concrete filled composite drilled shafts is estimated be 10 to 20 percent higher than that of driven steel pipe piles.

Because of the noncorrosive nature of FRP materials, concrete filled GFRP mooring piles are more likely to meet the 75-year, maintenance-free requirement for Navy pier construction than steel piles. Thus, FRP drilled shafts were chosen as the primary design option for anchor piles. Appendix E contains detailed strength calculations for 6-foot (1.83-m) diameter concrete filled GFRP shafts. The design is based on data from large-scale tests conducted at Lehigh University and Rutgers University (Ref 6). The calculations assume that the concrete infill does not carry any tensile stress and that stress distributions are linear. In comparison with the test data, the design strength of the composite drilled shafts has a safety factor of at least 4. At the design limit state, the maximum tensile stress in GFRP shells is about 12.3 ksi (85 MPa). This

stress level is below the allowable working stress for GFRP (usually at 20 percent of the ultimate tensile strength, approximately equal to 14 ksi (96.5 MPa) in this case, see Refs 6 and 7). The calculations show that two mooring pile dolphins each consisting of six 6-foot (1.83-m) diameter concrete filled GFRP drilled shafts are adequate to resist the factored design wind and current loads.

### 11.6.2 Mooring Dolphin Cap

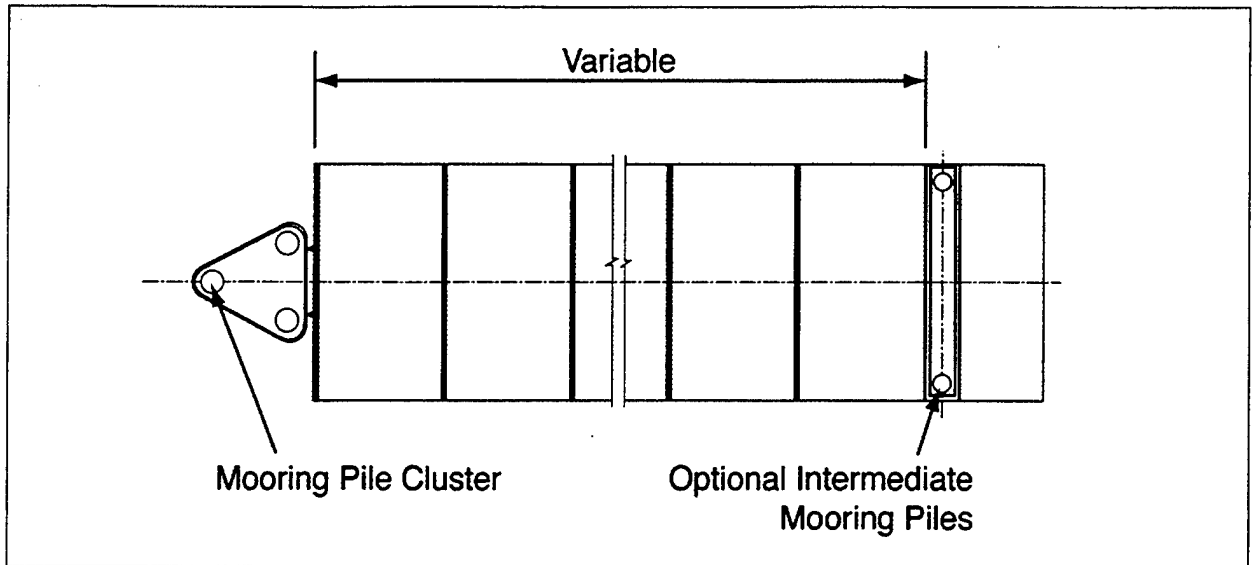
Anchor piles or drilled shafts are tied together at the top with a CFRP-reinforced concrete cap. The cap is sized to allow adequate spacing of the piles and to provide sufficient bearing surface to react loads from the floating pier. It is recommended that the mooring dolphin caps be prefabricated off site, i.e., precast/prestressed concrete shells are used as in-situ forms for placing cast-in-place concrete that ties all the anchor piles together. The off-site prefabrication method will minimize the on-site work and facilitate the construction logistics.

The configuration of the mooring dolphin caps is an important design consideration because it is directly related to the design of the pier hull and the mooring dolphin-to-hull connection. Three types of cap configurations were evaluated: (a) triangular cap, (b) square cap, and (c) circular cap. In order to provide full bearing surface against the floating pier hull throughout the entire tidal range, all cap blocks have a depth of about 25 feet (7.6 m). However, this depth should be optimized in future phases (see Figures 11-1 through 11-3).

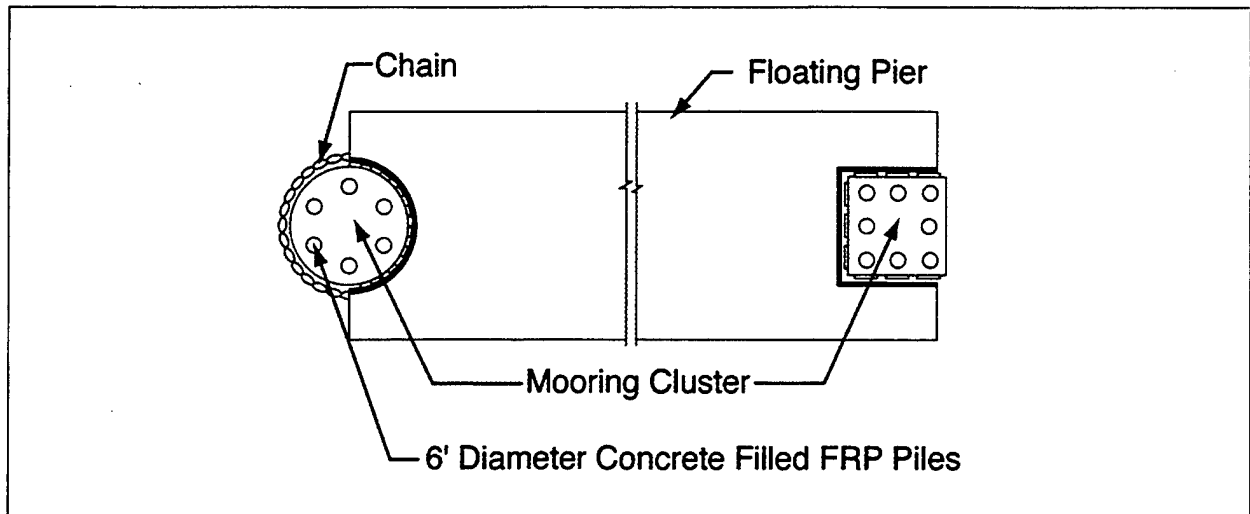
Configuration (a) consists of a triangular cap supported by three 10-foot (3-m) diameter piles or drilled shafts (see Figure 11-1). One method of achieving the mooring dolphin-to-hull connection is a "spud-and-shoe" type as commonly used in floating dry docks. Preliminary analysis shows that this mooring arrangement provides adequate lateral support for the pier. However, the traditional "spud-and-shoe" connection appears to be vulnerable to eccentric moments imposed by large lateral forces and yaw moments. The 75-year, maintenance-free requirement for this type of connection has yet to be proven.

Configuration (b) is a 45- by 45-foot (13.7- by 13.7-m) square cap supported by eight 6-foot (1.83-m) diameter piles or drilled shafts (see Figure 11-2, right side). The mooring dolphin-to-hull connection can be either a bearing type or a wheel/roller type. Bearing connections appear to be appropriate for large pier structures where thousands of tons of forces must be transferred to the mooring dolphin. The major detail design challenge of the square cap configuration is that the cap tends to rotate about the vertical axis as the floating pier deflects and yaws. The rotation of the cap imposes higher forces on the piles located on the corners of the cap and lower forces on the ones located on the sides.

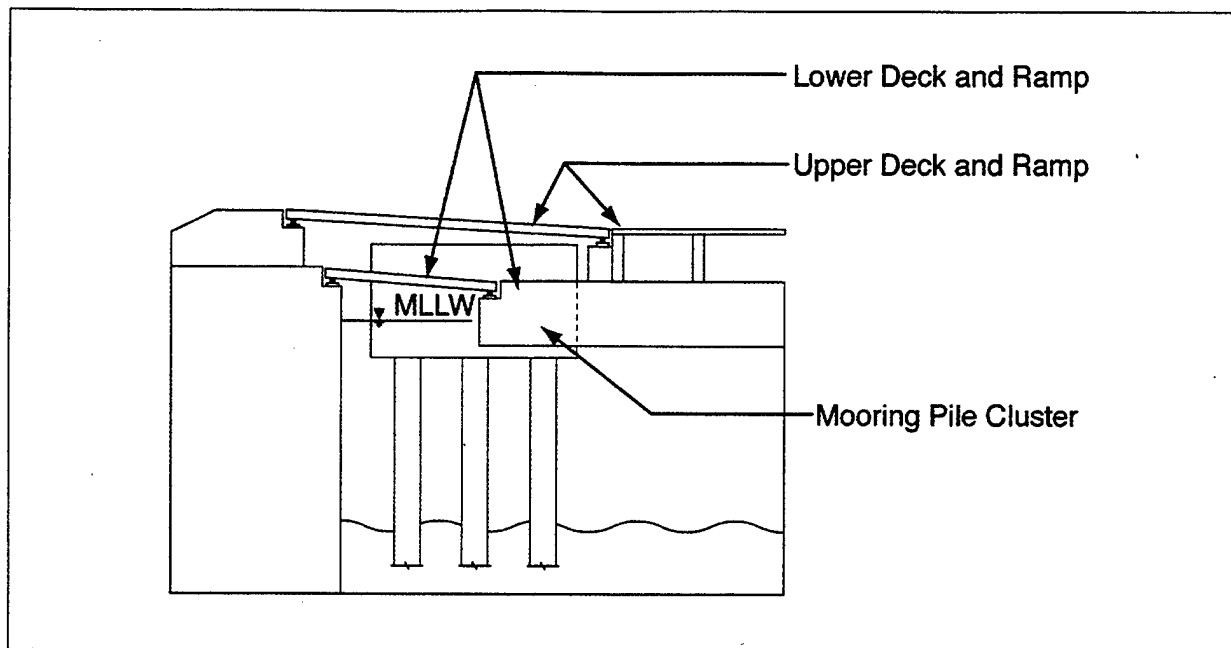
Configuration (c) is a 48-foot (14.6-m) diameter cap supported by six 6-foot (1.83-m) diameter piles or drilled shafts (see Figure 11-2, left side). The circular cap allows the pier to rotate and yaw freely without imposing significant stresses on the hull. Because the cap itself does not rotate with the pier, the six piles are uniformly stressed when resisting the lateral loads. In general, the circular cap configuration results in a more efficient and simpler design.



**Figure 11-1**  
**Mooring System for a Floating Navy Pier**  
 (Note: Pile or Drilled Shaft Mooring Concept)



**Figure 11-2**  
**Plan - Mooring System for a Floating Navy Pier**  
 (Note: Filled FRP Pile Mooring Concept)



**Figure 11-3**  
**Elevation – Mooring System and Approach Ramp**  
 (Note: Pier-to-Shore Interface Concept)

### 11.6.3 Mooring Dolphin-to-Hull Connections

These connections are the most critical elements in the mooring system, as the entire lateral force applied to the pier must be transferred through the connections into the mooring dolphin/anchor piles. Three types of mooring dolphin-to-hull connections were evaluated: (a) “spud-and-shoe,” (b) wheel/roller, and (c) high density polyethylene (HDPE) or ultra-high molecular weight polyethylene (UHMW-PE) bearing pads.

Connection (a), “spud-and-shoe,” has been commonly used in floating dry docks. Spud connections are designed to resist both tension loads and shear loads. In this case, tension spuds (rails) at the ends of the floating pier are connected vertically to the mooring dolphin caps with a shoe. The shoe locks onto one flange of the rail through the gripping action of its collar. The connection allows the spud to slide vertically with the floating pier but restricts any significant lateral movement of the spud. A common concern with this connection is its susceptibility to corrosion because the connection is often made of steel.

Connection (b), wheel/roller, allows the floating structure to move vertically while restraining any significant lateral movements. This type of connection has been used to restrain small floating platforms in marinas. The strength and flexibility of this connection for large floating structures has yet to be proven.

Connection (c), HDPE or UHMW-PE bearing pads, has a successful record of use on fender piles, fender panels, and other high abrasion surfaces. In navigation lock structures, HDPE strips have been installed on the gates and walls as a rubbing surface for tow barges. Reported field performance of this material in the locks has been excellent. UHMW polyethylene

plastic "timber" pads/strips have recently been marketed as a highly impact/wearing resistant material. These plastic timber pads/strips are reinforced with GFRP bars.

Of the three types of connections evaluated, HDPE or UHMW-PE bearing pads/strips appear to be the most promising option for provision of maintenance-free pier mooring connections.

#### **11.6.4 Other Guide Dolphin Mooring-Related Issues**

**11.6.4.1 Effects on Floating Pier Prestressing Requirement.** When restrained laterally only at its ends by mooring dolphins, the floating pier acts like a simple beam when subjected to lateral loads. The side plates of the hull mainly resist the flexural moment, while the decks and keel plate resist shear. Structural calculations based upon the simple beam model are given in Appendix E. The calculations show that approximately 760-psi (5.2-MPa) effective prestress is required in the side plates of the hull in order to eliminate tension in concrete under the given loads. This is a significant cost that must be considered when determining the most cost-effective mooring scheme.

### **11.7 MOORING WITH A TENSIONED LINE SYSTEM**

To ensure the intended operation of the tensioned line mooring system, the installation must be performed correctly. Lines must be jacked to provide equal tension in each of the moorings to assure equal distribution of the applied loads from the floating dock among the mooring lines. Similar systems have been installed successfully in the past, noticeably the anchorage system for the Lake Washington floating bridges in Seattle, Washington. The system would need to be checked periodically for correct tension, corrosion, and wear and tear. Periodic underwater inspection of system components, including the cathodic protection, anchors, and sinkers, would also be required.

The line mooring system investigated here was designed for a typical set of environmental and operational requirements. These were a lateral load of 3,700 kips (16.5 MN), a water depth of 40 feet (12.2 m), and a tidal range of 6 feet (1.83 m). Mooring line systems using a combination of chain and either steel or synthetic rope were considered. Relative motion between the pier and the berthed vessel was assumed to be zero.

#### **11.7.1 Materials Considered for Tensioned Line Moorings**

**11.7.1.1 Synthetic Rope.** Synthetic rope was investigated for use in the mooring system because of its very low modulus of elasticity that could be useful in situations where shallow water occurs with a large tidal range and short length of rope. Given the availability of synthetic lines only up to 5 inches (125 mm) in diameter, with a breaking strength of 680 kips (3,000 kN), and a safe working load of 90 kips (400 kN), it is not practical to use synthetic rope. Using nylon rope, for instance, would have resulted in at least 86 lines, which was considered excessive.

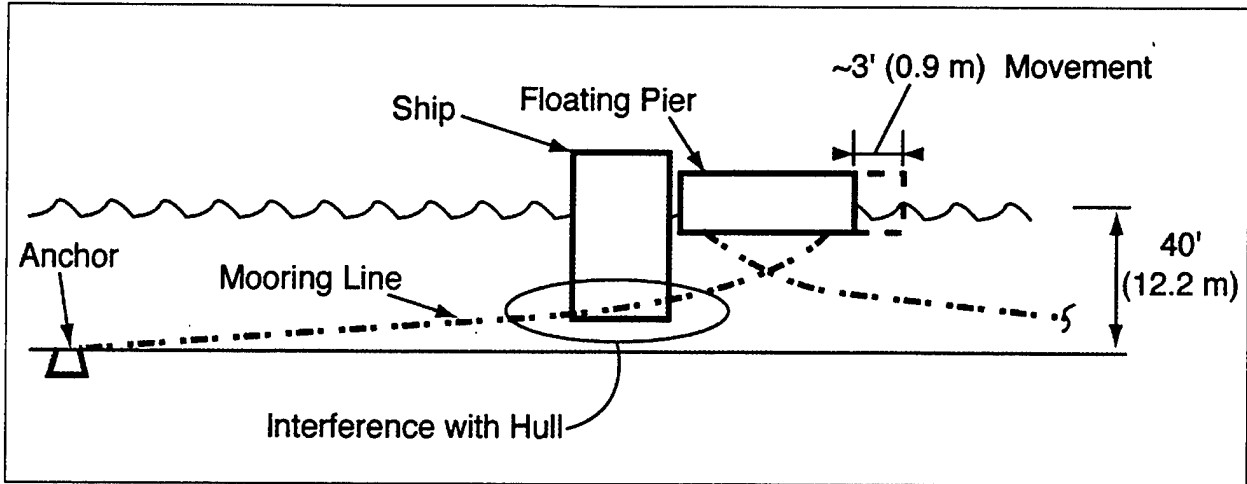
**11.7.1.2 Steel Bridge Strand.** Steel strand has a relatively high modulus of elasticity. It is, therefore, necessary to consider carefully the effect of tidal variation and length of the mooring lines on the line forces. Two mooring configurations were considered:

- A mooring line sufficiently long to allow tidal variations without excessive load increase in the line was investigated initially. Although this configuration has some beneficial features, it was judged unsatisfactory as there was not enough clearance between a taut mooring line and the hull of a berthed vessel. See Figure 11-4 and Drawing S-5 (at the end of the report in Drawings). This system also permits significant lateral movements under the applied lateral load.
- To increase the clearance between the mooring line and vessel and reduce displacement under applied load, a sinker weight was added to the line just outboard of the pier fender system. This had the advantages of: (a) lowering the mooring line profile such that it cleared the hull of the berthed vessel, and (b) reducing the required length of the mooring line. It was estimated that 4-inch (100-mm) bridge strands, with a minimum breaking strength of 1,940 kips (8,600 kN) and a safe working load of 650 kips (2,900 kN), would be required every 140 feet (42.7 m) on each side. The sinker was located just beyond the edge of the pier to allow easy access for maintenance. The line between the sinker and anchor was sufficiently long to develop only small angles at the anchor. The sinker was estimated to weigh 35 kips (156 kN), and the length of mooring line was expected to be about 200 feet (61 m). The movement under the maximum lateral load was expected to be 1.5 feet (0.46 m). Whether this movement poses an operational difficulty was not determined, but earlier studies indicate that the shore side connection will have to be specially designed to accommodate the angle change associated with this motion. See Figure 11-5 and Drawing S-5 (at the end of the report in Drawings).

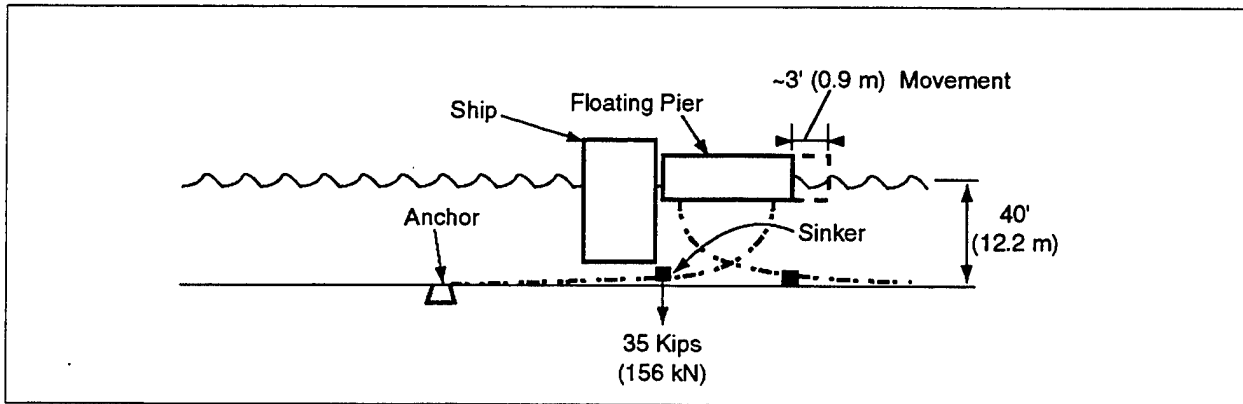
## **11.8 COMBINED MOORING LINE AND MOORING DOLPHIN/ANCHOR PILE SYSTEM**

An alternative mooring system consisting of a mooring dolphin/anchor pile at the shore end and splayed mooring lines at the offshore end was also briefly considered. This system will require three mooring lines in each direction. Mooring lines would consist of 4-inch (100-mm) chain and steel bridge strand similar to that described previously.

This system is potentially less sensitive to ground movements during an earthquake than the concept with mooring dolphins at each end, yet provides reduced lateral displacements at the shore end, which is desirable because of utilities connections and transfer bridges. This concept should be further developed during Phase 2 considering total global loads and motions.



**Figure 11-4**  
**Long Tensioned Steel Mooring Line Concept**



**Figure 11-5**  
**Steel Mooring Line with Sinker Concept**

## 11.9 COMBINED MOORING SYSTEM INCORPORATING TRANSFER SPAN

A variation of the combined mooring line and mooring dolphin system is to transfer longitudinal mooring loads through the pier-to-shore transfer span to a reaction abutment built onshore. The advantage of this system is that it avoids the more costly in-water dolphin construction. This approach increases the design complexity of the transfer ramp and will be more easily implemented in situations where the transfer ramp can be less than 200 feet (61 m) long.

## 11.10 CONCLUSIONS

In summary, the preliminary evaluation of the mooring systems indicates that a system of mooring dolphins at each end of the floating pier is feasible. Each mooring dolphin would consist of a 48-foot (14.6-m) diameter circular pile cap supported by six 6-foot (1.83-m) diameter concrete filled FRP pipe piles (drilled shafts). The preferred mooring dolphin-to-hull connection appears to be HDPE or UHMW-PE bearing pads/strips. The combined line mooring dolphin system and its variation with the reaction abutment onshore were also judged to have potential benefits and should be further developed in Phase 2.

## 11.11 REFERENCES

1. Naval Facilities Engineering Command. NAVFAC DM 26.6: Mooring Design Physical and Empirical Data: Vessel and Ship Characteristics, Mooring Lines and Chain Buoys, Anchor and Riser Type Mooring Systems. April 1986.
2. American Society of Civil Engineers. "Seismic Guidelines for Ports," Technical Council on Lifeline Earthquake Engineering, Monograph No. 12, 1998.
3. California Department of Transportation. "Bridge Design Specifications."
4. Naval Facilities Engineering Service Center. "Seismic Criteria for Marine Oil Terminals," by John M. Ferritto.
5. Federal Highway Administration. Publication No. FHWA-RD-91-006: Guide Specification and Commentary for Vessel Collision Design of Highway Bridges.
6. Lancaster Composite, Inc. "Precast Composite Containment Pile, Part 1."
7. Naval Facilities Engineering Service Center. NFESC SP-2018-SHR: Literature Review of Durability of Composites in Reinforced Concrete, by L.J. Malvar.



## SECTION 12 FENDERING SYSTEMS

Fendering system designs will be performed by the Navy and integrated with this work in a future phase of this program. Intuitively, it appears that fender systems for long-span pier concepts would be slightly more expensive and for floating piers slightly less expensive than the baseline structure fender system. This is because the required vertical extent of the fendering system necessary to accommodate tidal variations is less for a floating pier that rises and falls on the tide with the ship. While the vertical and horizontal extent of the hull plating (wall) of a floating pier is very convenient for the attachment of fender units, the limited concentrated load capacity of the plating is something that must be considered in the design of the fender system.

## **SECTION 13 MAXIMIZING THE USE OF EXISTING FRP COMPOSITE MATERIALS FOR PIER HARDWARE AND ANCILLARY APPLICATIONS**

Opportunities exist now for the use of plastics and FRP materials in pier construction. Many of the applications result from experience in the chemical processing industry and the oil and gas production industry, including offshore exploration and production platforms. Lightweight, corrosion resistant, and low-maintenance FRP composite materials have been used successfully for a significant time period. A list of practical applications is presented below. A more extensive listing of potential commercially proven applications of FRP composite materials to Navy floating piers was completed in collaboration with the Composites Institute and is included as Appendix F of this report.

### **13.1 LOW-PRESSURE SUPPLY AND WASTE DISPOSAL SYSTEMS**

FRP low-pressure piping is a well-developed technology that is directly applicable to this project. The following systems and system features can benefit from the use of FRP materials:

- Low-pressure piping and hangers
- Wet wells, tanks, and vaults
- Oil/water separator tanks
- Scuppers
- Trench drains and covers
- Gutters and downspouts
- Manhole covers and frames
- Water/wastewater products and accessories (flumes, baffles, chemical storage tanks, covers)
- Desalination equipment

### **13.2 HIGH-PRESSURE SUPPLY SYSTEMS\***

- Piping and hangers

\* FRP not suitable for steam piping or high-pressure air

### **13.3 STRUCTURAL-RELATED APPLICATIONS FOR FRP COMPOSITE MATERIALS**

The process industry has made use of FRP secondary structural elements for many years. Many of these features and products have been developed with rugged service and corrosion prevention as the primary drivers. This background of successful service makes these FRP elements directly applicable to this project.

- Ladders
- Stairs and landings
- Personnel platforms
- Hand rails
- Grating and flooring
- Brows/gangways
- Concrete reinforcement (rebar, tendons, dowel bars, structural stay-in-place forms)
- Primary and secondary structural elements (columns, beams, and decking)
- Pedestrian and vehicular bridges and bridge decks
- Manway and safety cages
- Utility trench cover panels

### **13.4 ELECTRICAL-RELATED APPLICATIONS FOR FRP COMPOSITE MATERIALS**

The electrical industry has used FRP components for a number of years. The use of FRP elements for the following items is directly applicable to this project.

- Cable trays
- Hangers
- Conduits
- Pull boxes, junction boxes, cabinets, enclosures, and vaults
- Light poles
- Utility poles
- Strain rods
- Pole-top hardware
- Cross arms
- EPRI-type (shed) insulation
- Hot sticks, man-buckets, and booms

### **13.5 MISCELLANEOUS APPLICATIONS FOR FRP COMPOSITE MATERIALS**

All other areas of the project will be systematically evaluated for the cost-effective use of FRP components. Some other areas that are candidates for FRP use include the following:

- Corrosion resistant coatings (reinforced and flake glass filled)
- Ducting/hoods
- Fender panels, piling, and hardware
- Mooring lines
- Structural piling
- Signs
- Architectural products (fascia, cladding, etc.)

- Paneling
- Fence posts and railings
- Door and window framing
- Glazing and translucent paneling
- Shelters
- Curtain walls
- Communications towers

Most of the applications, except for the miscellaneous category, are on nonchafing surfaces or lightly abrasive exposures. Ultra-high molecular weight polyethylene (UHMW-PE) facing has been used successfully on rubbing and highly abrasive surfaces (e.g., fender facing, rope slides, chute lining, etc). UHMW is very expensive and is usually custom manufactured for applications other than flat sheets. UHMW can be scored and gouged by sharp steel edges and hence its use should be limited to areas that can be easily serviced. In most cases, such gouges affect the cosmetic appearance of the part and not structural performance or long-term durability.

### **13.6 ITEMS THAT COULD BE FABRICATED FROM PLASTIC**

The following items are presently made from metal castings and machined parts. There are limited possibilities for manufacturing some items in FRP composites or plastic.

- Valves and pumps
- Hydrants
- Chains
- Capstans (castings)
- Bitts and bollards (castings)
- Bollards (concrete filled)
- Cleats (castings)
- Expansion joints (roadway)
- Curb edging
- Rope slides

### **13.7 FRP COMPOSITE COMPONENT ISSUES**

The ultra-violet (UV) protection, fire protection, and resistance to vandalism are some of the under-appreciated benefits of FRP composites. UV protection is typically provided by: (1) adding UV inhibitors into the FRP matrix resin, (2) use of a specially formulated UV resistant gel coat, or (3) choices of inherently UV-resistant resins, such as acrylics, etc. With today's FRP materials technology, products can be designed for long-term UV exposure when the performance conditions are specified by the engineer. Hundreds of millions of pounds of FRP are used annually in outdoor applications, such as electrical transmission and distribution pole-top hardware, and marine, truck/trailer, automotive, and architectural products.

Fire protection can also be provided by applying an additional exterior fire retardant material, such as ALBI-CLAD, SP 2001 FIRE COATING, INTUMASTIC 285, etc. These materials are either thin film intumescent coatings or ceramic-based insulators, typically applied to exposed steel members in building frames. Some of these materials must be top coated, others are formulated with an epoxy-type binder that forms a tough surface. The intumescent coating softens and expands to form a protective layer around the substrate to which it is applied. Fire endurance testing to establish a fire rating is typically not done for FRP products (e.g., ASTM E-119 "Fire Tests of Building Construction and Materials"). Testing for flame spread and smoke density of FRP products is performed according to ASTM E-84 "Surface Burning Characteristics of Building Materials." With special fire retardant additives, Class A ratings are routinely achieved in this test. Some testing has been done on FRP products coated with fireproofing materials to determine a fire endurance rating.

Use of halogenated or brominated resins or antimony trihydrate (ATH) is common to achieve factory mutual "1 hour" fire ratings in construction paneling and related applications. All of the busses and cable trays in the recently completed 22-mile "Chunnel" between England and France feature fire-resistant, nonconductive, and corrosion-resistant FRP laminate with a thermosetting acrylic resin.

In general, FRP composites can be designed with vandalism and damage resistance in mind as evidenced by their use as graffiti-resistant urban bus and transportation signs, paneling in public lavatories, counter tops, telephone booths, and electrical/telecommunications housings. All FRP manufacturers of such products offer repair materials. In addition, all automobile body shops and marinas provide color-matching repair materials and services. Damaged FRP products can also be repaired with epoxy repair materials. Damaged FRP high-pressure piping should be replaced. Damaged low-pressure piping can be field repaired by wrapping an FRP mesh cloth around the damaged area, impregnating with resin and then curing it. However, proper material selection and quality construction procedures are required for any repair procedures. It should be repeated that many FRP products have hard and durable surfaces that cannot be easily damaged.

The very qualities of durability that are the subject of concern to marine/waterfront engineers (corrosion-resistance, nonrotting, water resistance, etc.) have been successfully demonstrated in the watercraft that use these same land-based marine installations now being considered as new applications for FRP materials. The materials of FRP boats are often more durable than the traditional materials (steel, wood, concrete, aluminum, etc.) of the shore facilities that they use. Experience regarding UV resistance, freeze-thaw, fire, mechanical durability, damage resistance, and related issues is available from more than 50 years of experience in the marine industry with FRP composites.

### **13.8 COSTS OF FRP COMPONENTS**

In discussions with FRP fabricators, the general sense is that FRP products may be up to 25 percent more expensive than equivalent galvanized steel fabrications, competitive with aluminum fabrications, and cheaper than stainless steel fabrications. In many cases, the FRP product is selected for its benefits over steel fabrications; namely, its light weight (generally one-fifth the weight of steel) and corrosion resistance.

The majority of construction/civil engineering applications in which FRP is specified require that the "installed cost" of the FRP product be equal to or lower than the traditional material.

Qualitative costs for FRP versus galvanized steel fabrications have been collected from local distributors based on some sample fabrications for a ladder, grating, and pressure piping. The pricing is based on fabricated parts and does not include installation. Installation costs for FRP are expected to be significantly less than for steel fabrications because of the reduced weight.

	<u>Galvanized Steel</u>	<u>FRP</u>
Ladder – wall mounted	\$31/lin. ft. (\$102/m)	\$40 ~ \$50/lin. ft. (\$131 ~\$164/m)
Grating	\$9/sq. ft. (\$97/m <sup>2</sup> )	\$14 ~ \$15/sq. ft. (\$151 ~ \$161/m <sup>2</sup> )
Pressure piping	\$19.30/lin. ft. (\$63.3/m)	\$36.20/lin. ft. (\$119/m)

Notes:

1. The above are list prices and do not account for Contractor's discounts or quantity discounts.
2. Basis for Estimates

Ladder: (galvanized steel) 1-foot 6-inch (457-mm) inside dimension, PL 2-1/2- x 3/8-inch (64-mm x 9.5-mm) side rails, 1-inch (25-mm) diameter solid rungs, supported at 4 ~ 6 feet oc (1.2 ~ 1.8 m)

(FRP) 1-foot 6-inch (457-mm) inside dimension, 2- x 0.156-inch (50-mm x 4-mm) square tube side rails, 1-inch (25-mm) diameter solid rungs, supported at 4 ~ 6 feet oc (1.2 ~ 1.8 m)

Grating: (galvanized steel) 1-1/4- x 3/16-inch (32-mm x 5-mm) b/b, 1-3/16-inch (30-mm) c/c; cross bars 4-inch (100-mm) c/c, serrated, banded

(FRP) Duradek I-6000, 1-1/2-inch (38-mm) b/b, 1-1/2-inch (38-mm) c/c; cross bars 6-inch (150-mm) c/c, anti-skid coating

Pressure Piping: (galvanized steel) 8-inch (203-mm) diameter, Schedule 40, ASTM A 53, Grade A

(FRP) Centricast RB 2530, epoxy pipe, 8-inch (203-mm) diameter

3. Pricing data provided here is based on input from a single manufacturer.

A further comparison of installed piping prices was made using MEANS 1998 "Building Construction Cost Data." This comparison confirms the higher initial prices for FRP piping and also the significantly lower installation costs for FRP piping. The total installed cost given in MEANS for FRP piping is actually lower than for galvanized steel piping. At this point, it would be conservative to assume that using FRP piping will not increase the cost of piping for a new pier. This work should be further corroborated in future phases by actual contractor estimates for a sample piping layout. Fireproofing of FRP pipe was not included in cost estimates. For a detailed summary of FRP piping, please consult the "Fiberglass Pipe Handbook," a 1992 publication of the Composites Institute's Fiberglass Pipe Institute in association with the American Waterworks Association (AWWA). This publication includes the history of FRP pipe, materials properties, manufacturing, durability, design (both above ground and buried installations), joining systems, etc. Copies are available from the Literature Department of The Society of the Plastics Industry, Inc. in Washington, DC. Reference Catalog No. AF-165, or contact the Composites Institute offices in Harrison, New York.

Custom fabrications, which cannot be assembled from ready-made FRP components, will cost significantly more than custom fabricated steel components.

FRP bolts and other mechanical fasteners for FRP components are very expensive and, hence, many fabricators will suggest stainless steel fasteners to reduce costs unless FRP fasteners are mandatory. Also, the current state-of-the-art for threaded FRP bolts is relatively limited, and achieving high levels of torque or tensile capacity are not practical with these products.

### **13.9 COMMUNICATION WITH COMPOSITES INSTITUTE'S MARKET DEVELOPMENT ALLIANCE**

A coordinating meeting was held with the Composites Institute's Market Development Alliance (CD-MDA). The MDA publicized this project to its approximately 350 company membership and solicited comments on the report as well as literature, case histories, design information, product data sheets, etc. from members with products that could be considered for this project. A comprehensive package of product literature has been forwarded to BERGER/ABAM.

The MDA also provided BERGER/ABAM with the Composites Institute "First Source" Buyers Guide. This publication lists approximately 750 FRP composites products suppliers by type of product manufactured (grating, ladders, pipe, tanks, etc.) in the same table layout format as the BERGER/ABAM report. As a 501.c.3 not-for-profit trade association, the Composites Institute and its member organizations, including the MDA, cannot endorse or show preferential treatment to one industry member company over another. However, with Composites Institute's "First Source" publication, all of the significant product information of the United States FRP composites industry, including contact information, is now available to BERGER/ABAM and the U.S. Navy through First Source. The tables contained in the First Source can also be reproduced by BERGER/ABAM and the U.S. Navy without restriction for the purposes of illustrating the product and manufacturer offerings of the United States FRP composites industry.

## **SECTION 14 ADVANTAGES OF SYSTEMATIZED PLANNING, DESIGN, AND CONSTRUCTION FOR NAVY FLOATING PIER PROGRAM**

### **14.1 STATUS QUO IN PIER PROJECT DESIGN AND DEVELOPMENT**

Currently, Navy pier design is either performed by in-house Navy personnel or by a consultant team selected for a specific project through a competitive qualifications based selection process. Guidance is provided to designers in the form of Navy design manuals and guide specifications. The design manuals and specifications are necessarily broad so that they can be applied to the wide variety of site-specific situations that must be dealt with for a typical Navy pier design project.

The pier facilities that result from the status quo are generally acceptable for current use, although the operational effectiveness and life-cycle cost efficiency of each pier installation varies as a result of the design team's experience in dealing with both site-specific and operational issues and requirements. Additionally, the philosophy of the design team and the Navy user team interfacing with the design team have important effects on the overall pier design.

A further important variable in the delivery of a new Navy pier project is the construction team. The construction team includes both the contractor that has usually been selected for the job on the basis of a competitive bid and the Navy construction management team that overviews the construction effort. The skill of the construction contractor's forces and degree of attention paid to critical quality requirements of the pier project construction are important determinants in the overall life-cycle cost of a Navy pier facility. Each contractor generally uses locally available materials for the construction of the key structural elements of the pier (the concrete elements).

An important fact about the status quo is that the site-specific nature of both the design solutions used and the design and construction team itself results in a situation in which it is very difficult to translate important lessons learned on one project to improvements on the next project. This is true for the basic pier structure and for the various ship service subsystems involved.

### **14.2 POSSIBILITY OF SYSTEMATIZED PROJECT APPROACH**

The use of floating piers provides an important opportunity for the Navy to systematize the pier design and construction effort. A very important feature of a floating pier project is that it is much less site-specific in its requirements than is a conventional pile-supported pier. Just the fact that the floating pier is less reliant on local geotechnical conditions, local seismic conditions, and local tidal variations is very significant in allowing solutions developed for one floating pier project to be directly applicable to a floating pier project at a different site.

Because the design solutions have wide applicability from one project to the next, it makes good economic sense to invest in design guides and standards that will reliably result in operationally efficient economical facilities on project after project. Because each project will have many features in common, the collection of lessons learned from one project to the next will pay direct dividends. This commonality from project to project will allow improvements to



be made in the design guides and standards to an extent now not feasible or practical because of the extreme site-specific nature of current pile-supported pier construction.

Use of the same pier geometry and arrangement from project to project will foster the refinement and optimization of support systems for both first cost and life-cycle cost by allowing procurement, construction operation, and maintenance experience from one installation to be directly applied to the next. The procurement of Navy piers will become less like the procurement of one-of-a-kind racing cars and more like buying a family car at the local dealer.

#### **14.2.1 Modularity**

There are several levels of modularity that apply to floating Navy piers. At one extreme, an entire pier installation is a module that can be made to be largely interchangeable from site to site. For example, the Navy could commission the construction of several floating piers and decide late in the construction process where they are to be deployed. It is possible to configure ship support utilities to allow piers to accommodate a wider range of vessel types. The deployment planning for floating piers could be similar to that used for vessels of the fleet. Deployment would become a strategic decision much less linked to geography than current pier investments are.

It may also be operationally and economically advantageous to have the ability to bring an operationally obsolete 25-year-old floating pier to a central refitting facility for upgrading of ship support services. An operationally upgraded floating pier could be changed out for an operationally obsolete one with a few months of down time and near zero disruption to adjacent activities.

At the next level of modularity, one may think in terms of the length of the pier. Typically a floating pier will be constructed in modules from 250 to 500 feet (76 to 152 m) in length. These modules will then be prestressed together to form piers up to 1,500 feet (457 m) in length. It would be possible to develop piers that were completely operationally self-sufficient at a length of 700 feet (213 m). The piers could then be deployed as either a single fully operational 700-foot (213-m) facility or connected together to form a 1,400-foot (426-m) pier. This type of modularity would further increase the options that military facility planners have to work with.

The third level of modularity has to do with systems installed on the floating piers. Because the structural configuration of each floating pier can be made exactly the same as the next, it is possible to design subsystems that are truly modular. These systems could be made interchangeable from one facility to the next to an extent much greater than is now possible with the wide range of site-specific designed facilities that comprise the current Navy pier inventory. This has very important implications for maintenance, operational readiness, procurement, inventory requirements, and capital and life-cycle cost.

#### **14.2.2 Off-Site Construction**

On the surface, off-site construction appears to have some nominal advantages relative to improved delivery schedule and reduced construction period disruption. In fact, the real possibility lies in the incorporation of modern factory precasting and factory outfitting into the production of Navy piers. The precast industry has played an important role in increasing quality of construction elements while controlling costs. Conventional pier construction often makes good use of precast elements but the piling and panels are still installed by overwater

construction methods, one of the most expensive forms of construction in the civil construction industry. Precasting floating piers provides the opportunity to capture the quality, durability, and cost savings of factory precast construction while avoiding almost all of the costly overwater marine construction required for installation.

The precast industry now has many specialized facilities for the economical production of highway girders, piling, building units, etc. The industry has a well-developed system of standard concrete forms, standard connection details, well-developed quality control systems and procedures, standard tolerances, and a history of successful interfacing with utility subsystems. Any precast facility located near a waterway would be a candidate supplier of a floating Navy pier. Many of the industrial developments of this industry are directly applicable to the construction of high quality, durable, and cost-efficient floating piers.

### **14.2.3 Standardization**

The possibility of a non-site-specific "standard" design provides the opportunity of repetition in construction to an extent not possible with any other type of construction. This fact offers the potential for standardization of utilities and subsystems designs that are then exactly the same for each installation serving a particular vessel class and fender system standardization that is exactly the same from installation to installation. In addition to potential substantial cost savings, this standardization should pay benefits in maintenance, training, and operational optimization over time.

## **14.3 PROCUREMENT ISSUES**

Government procurement is regulated by a complex set of rules. The accomplishments of the United States space program and those of many military weapons programs has proven that high-quality results can be achieved within the constraints of government procurement regulations. What is difficult in any procurement scenario and particularly difficult in government procurement is to achieve both high-functional performance and quality and economy at the same time.

With concrete marine construction, the achievement of a threshold of quality that leads to long-term durability is of critical importance to the expected life of the facility. This is because Navy piers are subjected to a very unforgiving corrosive environment that will find every lapse in quality and exploit it into a maintenance problem. The objective of using FRP/concrete hybrid construction is to lessen the sensitivity of the basic structural system to corrosive attack, but attention to quality will still be of paramount importance with this new construction approach.

A procurement approach that provides strong incentives to reliably achieve necessary quality objectives is needed. The approach needs to provide a consistent incentive to all members of the project team from the design team through to the construction team. The procurement approach should recognize that much of the achievement of quality standards relates to individual performance. Therefore, the most effective form of incentives would be focused on the intended result and must be meaningful and available to all members of the team, including Navy construction managers and contractor personnel.

While a detailed study of procurement issues is beyond the scope of this effort, it is clear that procurement issues are as important to the life-cycle cost of a Navy pier as design issues.

## SECTION 15 PRELIMINARY COST CONSIDERATIONS

### 15.1 PRELIMINARY EVALUATION OF PROJECT COSTS

On a typical, recently designed berthing pier replacement project (e.g., MILCON P-327 at NAVSTA San Diego), the estimated project construction costs can be broken down as follows:

Structure	34% to 38%
Utilities	22% to 24%
Fendering	6%
Other works and contingencies	32% to 38%

The floating pier concept will likely have somewhat higher structure costs as a percentage of the construction project. A primary objective of the project is to significantly reduce the site-work component of the total project cost. A second project objective is to reduce the utilities portion of the cost somewhat by taking advantage of the ability to systematize the design and improve it from one project to the next. These capital cost factors are also accompanied by an increase in operational function and in the possible inclusion of crew amenities within the project that would otherwise have to be provided onshore.

### 15.2 PROJECT COST OBJECTIVES

The project cost objectives show that it is possible with the Navy floating pier concept to move from a capital cost position associated with prototype, first-of-a-type construction costs that may be higher than conventional Navy pier construction to capital cost equal to or less than conventional. This cost movement must be shown to be achievable in a reasonable number of projects.

### 15.3 MATERIAL COSTS

The proposed floating pier concept uses some materials that are more costly than currently used materials. While the costs of the CFRP mesh material is reducing at this time, it is not likely that it will reduce to lower than conventional concrete steel reinforcement. In making the choice to use more costly materials, we are acknowledging that there are unrecognized costs in terms of maintenance and earlier than desired facility replacement that are not accounted for in the use of some of the current lower cost materials.

### 15.4 PIER ELEMENT COSTS

In Section 7.5, a design philosophy that takes advantage of the corrosion resistant nature and the expected superior structural performance of CFRP mesh is presented. This approach, if

confirmation testing proves it to be workable, allows the higher material costs of CFRP mesh to be mitigated in allowing an overall reduction in material in the floating pier structure.

## 15.5 SYSTEMS COSTS

Systems costs will be controlled by thoughtful integration of the electrical and mechanical systems into the floating dock structure with the objective of making system installation and maintenance economical while optimizing the function of the systems. It is proposed that effort be devoted to developing modularized systems layouts that can easily be configured to support different classes of vessels. It is envisioned that the ship service systems will be installed on the floating dock in the off-site fabrication facility, thus significantly reducing installation costs.

## 15.6 SITE-RELATED COSTS

Site-related costs are often the most difficult project costs to control because they relate to things that are in fact beyond the control of the Navy and the design and construction teams. They are often related to things like site seismicity and site geotechnical features. The advantage of a floating pier with regard to site-related costs is that it minimizes the interaction of the facility with local site conditions. The influence of site conditions on floating pier moorings for example have significantly less project cost impact than the impact of piling design in an area with poor soils conditions.

## 15.7 LIFE-CYCLE COSTS

Appendix C of User's Guide UG-0007, Advanced Pier Concepts, by NCEL (1985) provides a comprehensive 25-year, life-cycle cost study for a Navy floating pier and a Navy pile-supported pier constructed in Seattle. The findings of this work showed life-cycle costs in favor of a floating pier. When a floating pier with greatly extended life and lower maintenance is considered, the results will be even more in favor of the floating pier.

The NCEL study compares a 1985 Navy floating pier conceptual design with a typical fixed, single-deck, pile-supported pier of the latest design in 1985. The comparison was intended to provide a suggested methodology for analyzing costs, and an example of typical costs that may be assigned to construction, operations, and maintenance of a floating pier versus the standard Navy, single-deck, fixed pile-supported pier.

To summarize this effort, the cost analysts found that in a 25-year life-cycle cost analysis the floating pier has a net present value advantage of about \$2.85 million. The fixed pier was found to cost less initially, but the floating pier was found to have significant advantages in operations, maintenance, and terminal value. The 1985 findings are as follows:

- "Swings in construction costs will impact the comparison far more than all other costs combined; more so, however, for the floating pier than the fixed pier. Even so, any variance is expected to be in the same direction for both alternatives keeping the relative comparison essentially unchanged.

- Operational costs impact the fixed pier life-cycle cost in twice the rate as the floating pier. Accuracy of the estimate for the fixed pier is considered much better with one-half as much chance for variance. The greater portion of the difference in operational costs between the pier designs is considered highly accurate.
- Similarly, maintenance and repair costs are considered extremely accurate relative to each other. Variances will change the estimates for both piers in the same direction with little or no impact on the comparison.
- A 60 percent terminal value for the floating pier reduces the net present value by only 5 percent. Lesser assigned value will have a correspondingly decreased impact on the total. The fixed pier terminal costs have negligible affect on the comparison.”

It is noted that this analysis gives very little credit to the value of the floating pier at 25 years. This is the point when one would envision refitting a floating pier with new ship support systems to support new technology vessels for the second 25 years of its life. It has been acknowledged that often the cost to upgrade systems on a conventional fixed pier is cost prohibitive when compared with a new pier. This will not be the case with the new Navy floating pier.

Thus in the second life-cycle analysis of the refitted modernized floating pier from year 25 to year 50, the capital cost of the pier structure for the refitted pier will be near zero. The value of the refitted pier will be essentially the same as a new pier. One must consider this fact in making decisions about facilities like this with very long service lives in order to find the real value in the Navy of today investing in facilities to be used by the Navy of tomorrow.

## **15.8 PHASE 2 COST ESTIMATING**

Cost estimating in the Phase 1 effort has been limited to parametric material variations to determine the cost consequence of the use of materials of differing cost in the basic structure. Without a preliminary design, it is not possible to accurately estimate construction costs. With the results of the Phase 2 preliminary design and input from the Phase 2 constructability evaluations, it will be possible to develop cost estimates based on material quantities and labor and equipment requirements for the various construction activities.

## **SECTION 16 EVALUATION OF RECOMMENDED PHASE 1 CONFIGURATION AGAINST CRITERIA**

The basic recommendation of the Phase 1 effort is to move forward with the development of a floating pier of the configuration shown in Drawing S-2. The primary structure will be developed using an FRP/concrete hybrid design that incorporates encapsulated steel post-tensioning used in combination with CFRP mesh elements for reinforcing in a matrix of lightweight concrete. Other features of the facility will systematically incorporate the maximum practical amount of FRP elements with the overall objective of providing a very high level of functional performance while providing very long-term durability. All of this will be accomplished in the most economical way possible.

### **16.1 TECHNICAL MATURITY OF PROPOSED SOLUTIONS**

Initially, a number of new structural configurations were evaluated to take advantage of the unique properties of FRP materials in floating pier construction. As these configurations were investigated in more detail, it became clear to the project team that a concept that used substantial amounts of a relatively low cost construction material would be needed to offset the high cost of the structural grade FRP construction materials. Many of these materials are 20 plus times more costly than conventional materials now used in Navy pier construction. Similarly, many of the new configurations represented risks relative to expected versus actual structural behavior that would require extensive performance confirmation testing.

#### **16.1.1 CFRP Prestressing Systems**

After a review of the available materials, it was decided that for materials to be used in conjunction with concrete that would experience significant levels of stress, CFRP materials were the best choice at this point in time and stage in development of civil engineering FRP materials. In order to take advantage of the high-strength characteristics of these materials, it was clear that the material either needed to be prestressed or located in structural sections in configurations that would accommodate the higher strains associated with using these materials at higher levels of stress.

CFRP prestressing tendons were initially investigated for use as global post-tensioning of the floating pier. While this may still be a good long-term solution, the technology related to the overall system of prestressing CFRP (tendons, stressing hardware, anchorages) was judged not suited for this application. CFRP prestressing is either too costly or not sufficiently technically developed for a large commercial application that relies totally on the CFRP prestressing material for its structural integrity.

A critical component of this decision was the timing of the need for production quantities of all of the elements of this system. The team judged that the amount of technical development still required for CFRP prestressing systems was not consistent with either the time available or the financial resources available in this program. As mentioned above, it is felt that there is long-term potential for this material and its continued development for commercial civil engineering application is encouraged.

### **16.1.2 CFRP Reinforcing Mesh**

Previous research on CFRP mesh and current efforts by various parties in the United States and elsewhere indicate potentially favorable behavior of concrete sections reinforced with this material. While there is still development to be done in both the manufacturing methods for mesh and in the appropriate ways to use it in design of concrete elements, it is felt that the level of development needed is consistent with the time available and resources available in this program. As outlined in Section 7.5, it appears that material at the cost recently quoted to the design team can be used in conjunction with encapsulated steel post-tensioning to provide a structure that meets the cost target of this program.

## **16.2 TECHNICAL RISK OF PROPOSED SOLUTIONS**

The selection of encapsulated steel prestressing systems eliminates the technical and cost risk associated with the prestressing. The decision to use a cellular concrete flat plate configuration for the pier structure eliminates the configuration technical and cost risk associated with many of the new structural configurations investigated in this effort.

The primary technical risk of the proposed solution appears to be that the CFRP mesh does not perform as expected. Acceptable performance could require more material in the mesh than currently anticipated. This is a cost risk that could cause the cost target to be exceeded. Tests on the reinforcing mesh may disclose unanticipated and unacceptable behavior that makes the use of CRFP mesh not feasible.

The risks associated with the other elements of the project are judged to be typical of any floating concrete facility. This is to say that experienced designers and contractors will be able to handle the design and construction issues with the same level of design, quality, and cost risk associated with typical civil engineering projects.

## **16.3 RISK ASSESSMENT FOR DEVELOPMENT**

A testing program is proposed for the next phase of the work to confirm performance of structural configurations using the CFRP mesh elements. There are structural performance issues to confirm and there are constructability issues to confirm. If the structural performance of the sections reinforced with CFRP mesh is acceptable, then methods of using the mesh material in a concrete construction production environment need to be defined. Basic information regarding applicable construction methods needs to be defined so that contractors can develop their own appropriate methods for producing elements reinforced with CFRP mesh that meet the quality objectives of the project.

Constructability issues that will need to be addressed include:

- Placement and securing the CFRP mesh in the concrete formwork
  - Flatness or contour of mesh
  - Tolerances on mesh cover

- Placement and consolidation of lightweight concrete around the mesh material
  - Self-consolidating concrete
  - Use of form vibrators
  - Use of special vibrating methods
  
- Handling of mesh material to prevent damage
  - Storage of mesh material
  - Fabrication of mesh "cages"
  - Lifting and placing mesh elements
  
- Protection of mesh splice lengths protruding from concrete elements

In addition to material cost risk with CFRP mesh use, there is the potential of labor cost risk. That is, the labor associated with construction using the CFRP mesh material must not be more than with conventional materials. The lighter weight of the materials has the potential for reduced labor. It remains to be seen if other requirements of dealing with the material create unanticipated labor requirements.

#### **16.4 RISK MITIGATION APPROACHES FOR THE PROGRAM**

Risk mitigation planning asks the question "What will be done if hoped for results are not achieved?" While we anticipate successful performance of CFRP mesh used in the manner envisioned here, the confirmation tests may produce unanticipated results. If the results are better than expected, we take advantage of the opportunity for material savings. The worst-case result of the confirmation testing would be that the sections reinforced with CFRP mesh seriously under perform to the extent that use of the mesh becomes uneconomical.

Constructability tests will be used to define basic methods of construction applicable to the use of the CFRP mesh materials. This will serve to mitigate cost risks associated with labor and handling requirements of the material.

Keeping the objective of the program in mind, one viable option would be to substitute stainless steel mesh for the CFRP mesh. This would be a viable fallback that is likely to yield a pier structure with durability characteristics similar to those expected from a facility constructed using the CFRP mesh.



## SECTION 17 DEFINITION OF FUTURE PHASE ACTIVITIES

The next phase of the program, if approved, will be focused on testing to confirm materials properties and structural design assumptions using the combination of lightweight concrete and CFRP mesh reinforcing. Additionally, the configuration of the pier will be further refined to quantify the various system and feature requirements so that the preliminary configuration developed in Phase 1 can be confirmed.

### 17.1 CAPABILITY ADDITIONS FOR PHASES 1A AND 2

Phase 1A of this program will test the performance of the proposed plating element design for the walls and keel of the floatation element of the pier. Phase 2, if authorized, will include further development of the functional design and a preliminary structural design of the overall facility.

It is anticipated that additional specialized capabilities should be added to the team for the next phases of the work. The proposed additions are listed below.

*Vansant and Gusler Incorporated (VGI)* - Ship service utility planning and layout on the floating pier to accommodate range of vessels to be berthed. Work to address optimizing maintainability and modularizing the various elements of the ship service utilities systems.

*ISIS Canada* - Technology transfer on Canadian experience using CFRP materials in civil construction projects. Planning for condition monitoring technology to be installed in the floating pier structure.

*The Glostén Associates* - Hydrodynamics evaluation of pier motions and wave forces and mooring design forces for the full range of wave environments expected at Navy floating pier deployment sites.

*Additional University or Contract Laboratory Testing Capability* - It will likely be necessary to involve either additional university support or contract laboratory support in order to accomplish the confirmation testing program in a timely fashion.

*Precast Concrete Fabricator* - It will be necessary to involve a precast concrete fabricator to cast test specimens and assist in the performance of constructability tests.

### 17.2 MATERIAL CONFIRMATION REQUIREMENTS

The material confirmation requirements to be addressed in Phase 1A include the determination of CFRP mesh engineering properties. Also included are the engineering and workability properties of a lightweight concrete mix suited for use with CFRP mesh reinforcing.

### **17.3 PROTOTYPE FRP COMPONENT DESIGN REQUIREMENTS**

The determination of CFRP mesh engineering design parameters when used in lightweight concrete is needed. The structural behavior of concrete sections reinforced with CFRP mesh material will also be confirmed.

### **17.4 OPERATIONAL REQUIREMENTS REFINEMENT**

A preliminary design that addresses quantified operational requirements will be developed. This design will be used as a basis for an Operational Peer Review Workshop involving the design team and Navy operations staff involved with pier functions.

### **17.5 INTERFACING REQUIREMENTS WITH COMPLEMENTARY PROGRAMS**

Interface requirements for the fender system being developed by the Navy will be developed. Other ongoing Navy design development activities will be reviewed with NFESC staff for applicability to this program. Interfacing plans will be developed as appropriate.

### **17.6 ANALYTICAL REQUIREMENTS**

A hydrodynamic analysis of the effects of the range of wave environments represented by the various potential floating pier deployment sites will be performed. This will quantify motion characteristics of the floating pier and define wave design forces and mooring design forces and considerations.

A preliminary structural analysis sufficient to fully support a preliminary design will be performed for the pier. This will include confirmation of the basic typical cross section and concrete outlines. It will also include the development of structural and mechanical concepts for the critical special features, such as:

- Joining area detailing
- Mooring system interface details
- Mooring system structures
- Working deck access ramp and access ramp interface with the pier
- Utility deck access provisions
- Fender attachment and support provisions

### **17.7 ELEMENT TEST REQUIREMENTS**

The requirement to determine the cracking behavior of lightweight concrete panels reinforced with CFRP mesh materials is anticipated. It is also anticipated that there will be a requirement to confirm the resistance to punching shear of the working deck reinforced with CFRP mesh materials.

## **17.8 COMPONENT TEST REQUIREMENTS**

A requirement to confirm the performance of critical joint details reinforced with CFRP materials by test is anticipated. This includes at a minimum the exterior wall to keel plate joint.

## **17.9 GLOBAL TEST REQUIREMENTS**

At this time, the requirement for global tests of the entire floating pier cross section is not anticipated. It is possible that the confirmation testing results will indicate a need for such testing. This requirement will be addressed at the time a need is indicated.

## **17.10 TECHNICAL RISK REDUCTION PLANNING**

Based on the results of the various tests, plans will be developed to address identified technical risks that could adversely influence project cost and schedule performance.

## **17.11 DETAILED FACILITY COST ESTIMATING**

Based on the results of the preliminary design, a detailed preliminary construction cost estimate will be developed. This estimate will be based on detailed quantity estimates and labor and equipment requirements for the construction effort.

## **17.12 INDUSTRY INVOLVEMENT PLANNING**

Phase 1 of the program benefited from the involvement of the Composites Institute. In Phase 1A and later phases, this involvement will be continued and expanded to other involved industry groups, if appropriate.

## **17.13 SUPPLEMENTAL FUNDING SOURCE PLANNING**

If desired by the Navy, possible collaboration with other FRP research efforts directed at civil infrastructure application and funded by non-Navy sources will be investigated. This may be an effective way of leveraging the Navy investment in FRP research and development.

## **17.14 PHASES 2 AND 3, COST AND SCHEDULE DEVELOPMENT**

At the completion of the Phase 1A efforts, a program, plan, and budget for Phase 2 of the program will be developed.

## SECTION 18 RECOMMENDATIONS

As outlined in the Executive Summary, it is recommended that this project move forward with the development of a permanently floating pier with utility galleries on either side of the pier below the working deck, as shown in Drawing S-2.

The cost range for the structure of a permanently floating facility like this is on the order of \$200 to \$220 per square foot (\$2,150 per square meter to \$2,367 per square meter) of working deck space. This value is based on current pricing assuming a one-of-a-kind project using construction technology similar to that used to construct modern floating bridges.

Assuming that 35 percent of a Navy pier project is due to the bare structure cost of the pier, the Concept 1 baseline conventional pier overall project cost would be \$140 per square foot (\$1,506 per square meter) divided by 0.35 equals \$400 per square foot (\$4,303 per square meter) of working deck space.

For a permanently floating facility, this same approach would result in a bare structure cost of \$200 per square foot (\$2,150 per square meter). If everything else remains equal, then the cost becomes  $\$400 + (200 - 140) = \$460$  per square foot (\$4,950 per square meter) of working deck space total project cost. The cost of the floating facility divided by the cost of the conventional pile-supported pier ( $\$460/\$400$ ) equals 115 percent of the cost of the baseline conventional pier. Thus, at this preliminary stage it appears that a floating facility has the potential of meeting the objective of being within the guideline of 120 percent of conventional for the initial project.

The cost of the Concept 2 off-site prefabricated float-in, pile-supported solution is estimated to be between the cost of the conventional pile-supported configuration and the permanently floating configuration. The potential cost and operational benefits of this approach and the potential increased value of this concept are not judged to be equal to those of the floating facility.

The actual impact on construction cost of using FRP materials and FRP/concrete hybrid designs is difficult to estimate at this point in time. This is because large-scale designs using FRP/concrete hybrids have not yet been accomplished and costs for the FRP elements, which will be used in the pier construction, have not yet been determined. It is anticipated that there will be a much better idea of the actual costs of using this technology at the end of Phase 1 of this effort.

It is our judgment, however, that the permanently floating facility offers the greatest prospect of reduced construction costs from the baseline of \$200 to \$220 per square foot (\$2,150 to \$2,367 per square meter) of deck area. This concept also offers the greatest number of previously listed potential benefits in terms of features, such as less construction disruption and greater opportunity for standardization. When costs are assigned to the additional benefits listed in Section 6.3, it is believed that the permanently floating double-deck pier facility is the most likely of the three concepts considered to offer the clear cost and operational advantages to the Navy that warrant further development of this concept.

NO.	REVISIONS

DATE APPROVED

DATE	REVISION

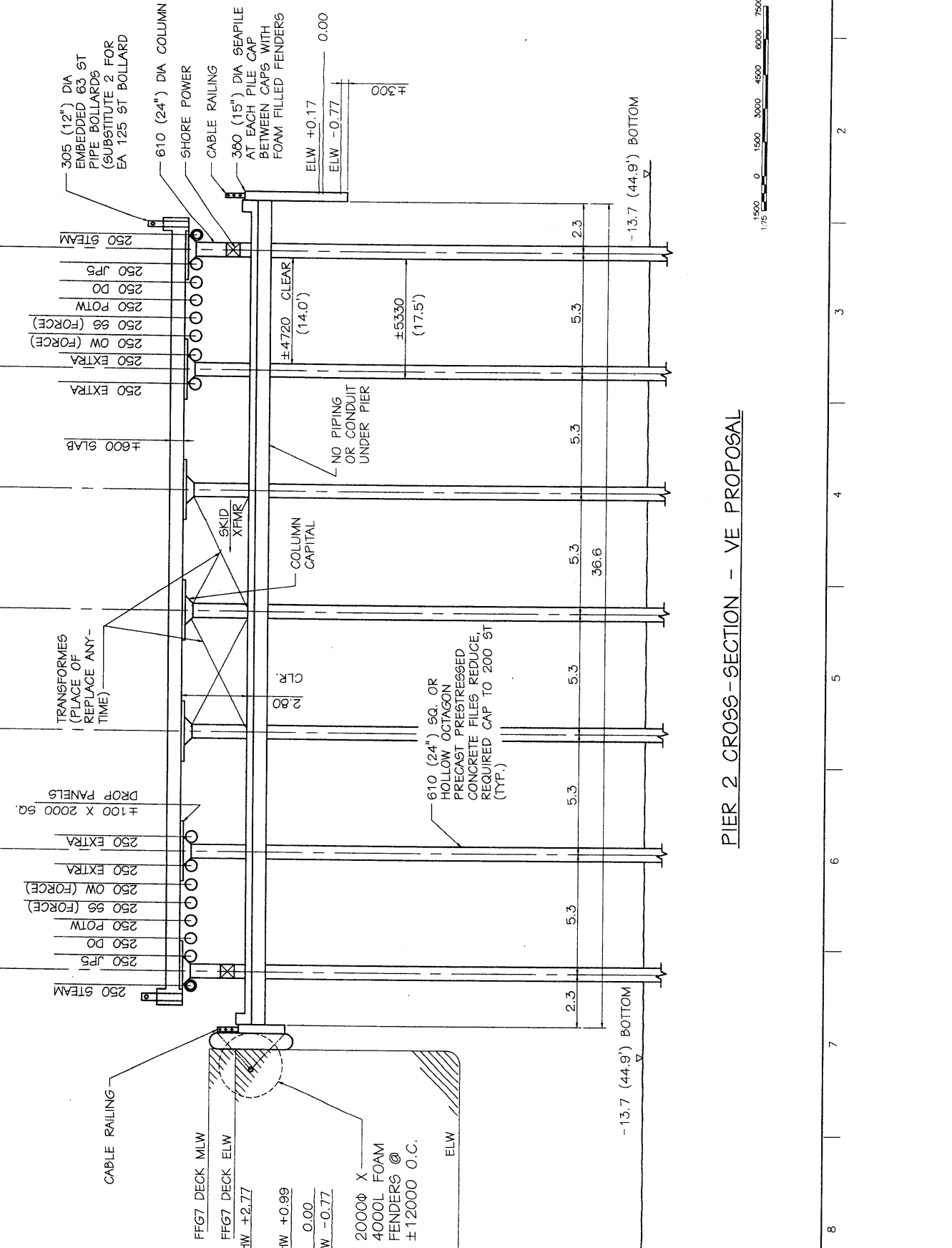
DESIGNER  
CHECKED BY  
DATE

PROJECT NO. 102014500  
DRAWING NO. 102014500-01  
DATE 11/29/2012  
SCALE AS SHOWN  
SHEET NO. 5-1

NAVSTA NORFOLK PIER 2 VE PROPOSAL  
MODULAR HYBRID PIER  
DOUBLE DECK PIER CROSS-SECTION

BERGER/ABAM  
NORFOLK, VIRGINIA

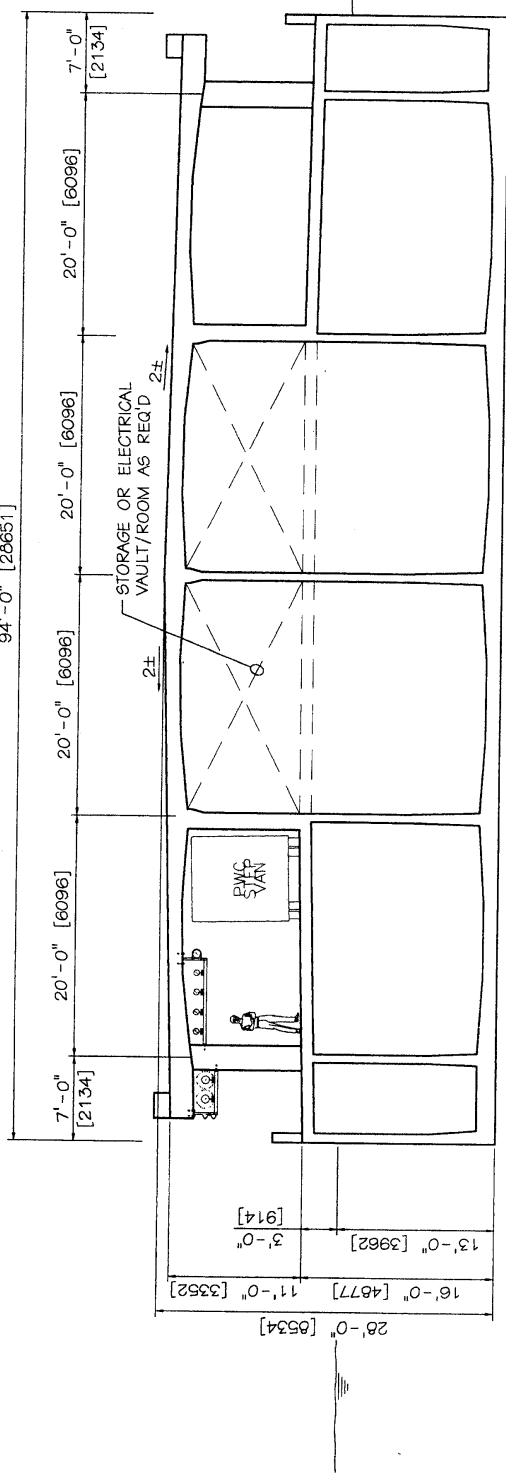
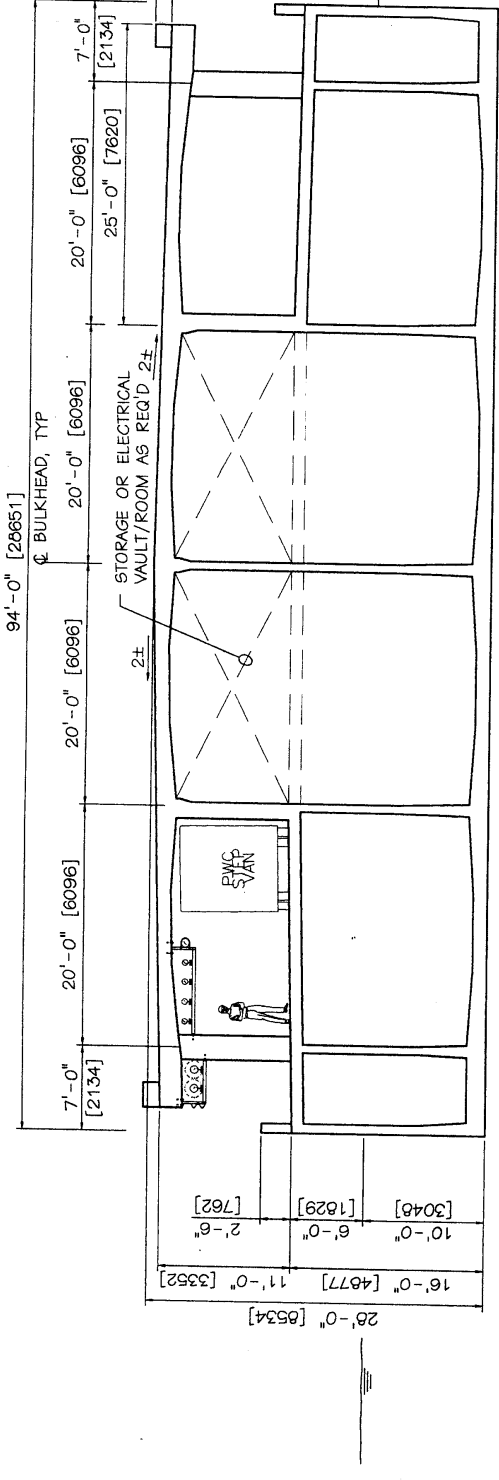
GENERAL NOTES:  
1. ALL DIMENSIONS ARE IN FEET UNLESS OTHERWISE SPECIFIED.  
2. ELEVATIONS ARE MEASUREMENTS FROM THE MEAN LOW WATER (MLW) OF THE ADJACENT WATERS.  
3. REFER TO THE PIER ELEVATION SURVEY FOR THE MEAN LOW WATER ELEVATION.  
4. THE PIER SHALL BE CONSTRUCTED TO REMAIN SERVICEABLE FOR A MINIMUM OF 20 YEARS.  
5. THE PIER SHALL BE DESIGNED TO WITHSTAND THE FULL EFFECTS OF WIND, WAVE AND CURRENT FORCES.  
6. THE PIER SHALL BE DESIGNED TO WITHSTAND THE FULL EFFECTS OF COLLISION FROM ICE.  
7. THE PIER SHALL BE DESIGNED TO WITHSTAND THE FULL EFFECTS OF COLLISION FROM SMALL CRAFT.  
8. THE PIER SHALL BE DESIGNED TO WITHSTAND THE FULL EFFECTS OF COLLISION FROM FISHING VESSELS.  
9. THE PIER SHALL BE DESIGNED TO WITHSTAND THE FULL EFFECTS OF COLLISION FROM PILOTS BOATS.  
10. THE PIER SHALL BE DESIGNED TO WITHSTAND THE FULL EFFECTS OF COLLISION FROM TUG BOATS.  
11. THE PIER SHALL BE DESIGNED TO WITHSTAND THE FULL EFFECTS OF COLLISION FROM LORRY VESSELS.  
12. THE PIER SHALL BE DESIGNED TO WITHSTAND THE FULL EFFECTS OF COLLISION FROM RO-RO VESSELS.  
13. THE PIER SHALL BE DESIGNED TO WITHSTAND THE FULL EFFECTS OF COLLISION FROM CRUISE SHIPS.  
14. THE PIER SHALL BE DESIGNED TO WITHSTAND THE FULL EFFECTS OF COLLISION FROM PASSENGER SHIPS.  
15. THE PIER SHALL BE DESIGNED TO WITHSTAND THE FULL EFFECTS OF COLLISION FROM MERCHANT SHIPS.  
16. THE PIER SHALL BE DESIGNED TO WITHSTAND THE FULL EFFECTS OF COLLISION FROM MILITARY SHIPS.  
17. THE PIER SHALL BE DESIGNED TO WITHSTAND THE FULL EFFECTS OF COLLISION FROM WAR SHIPS.  
18. THE PIER SHALL BE DESIGNED TO WITHSTAND THE FULL EFFECTS OF COLLISION FROM NAVAL VESSELS.  
19. THE PIER SHALL BE DESIGNED TO WITHSTAND THE FULL EFFECTS OF COLLISION FROM NAVAL AIRCRAFT.  
20. THE PIER SHALL BE DESIGNED TO WITHSTAND THE FULL EFFECTS OF COLLISION FROM NAVAL HELICOPTERS.



PIER 2 CROSS-SECTION - VE PROPOSAL

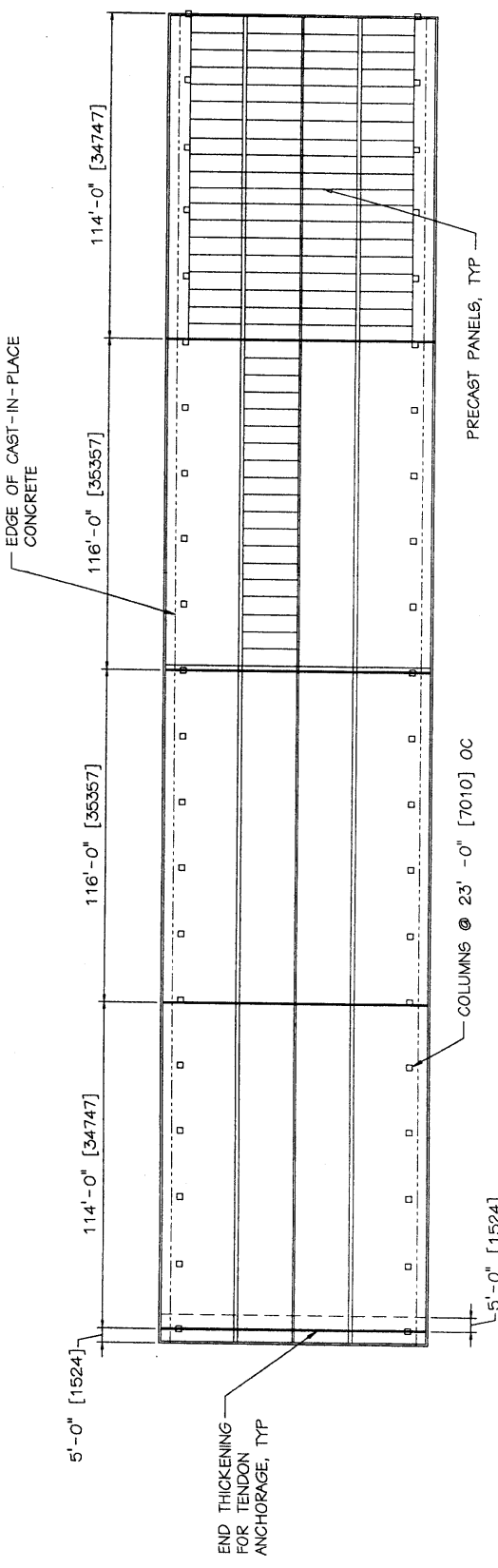
1 CROSS - SECTION (LIGHT SHIP)  
SCALE: 1"=5'

2 CROSS - SECTION (LOADED SHIP)  
SCALE: 1"=5'

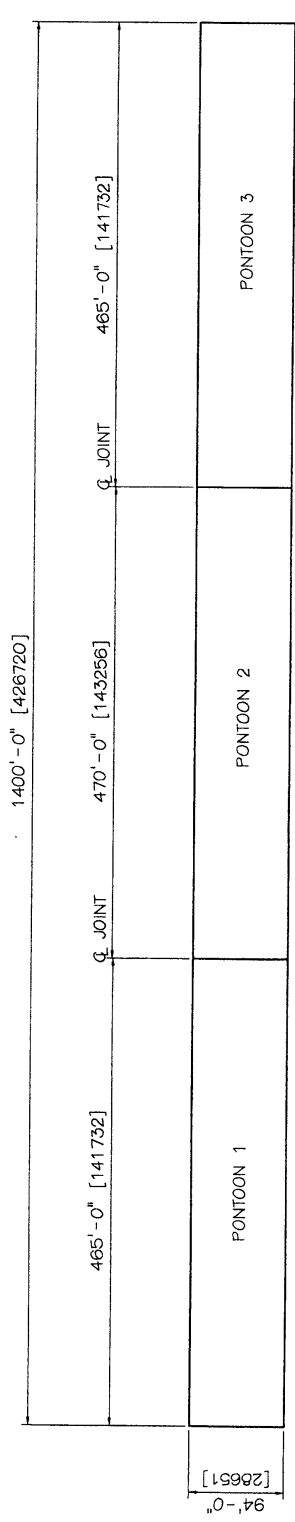


PROJECT: NAVAL STATION  
 MODULAR HYBRID PIER  
 PONTON AND PIER PLANS  
 NFEBC  
 DATE: 11/20/12  
 DRAWN BY: [REDACTED]  
 CHECKED BY: [REDACTED]  
 PROJECT NUMBER: 12000  
 SHEET NUMBER: S-3

NO.	DATE	DESCRIPTION



1 PLAN -- END PONTOON 3  
 SCALE: 1" = 20'



2 PLAN -- PIER AND PONTOONS  
 SCALE: 1" = 60'

1  
2  
3  
4  
5  
6  
7  
8  
 S-3

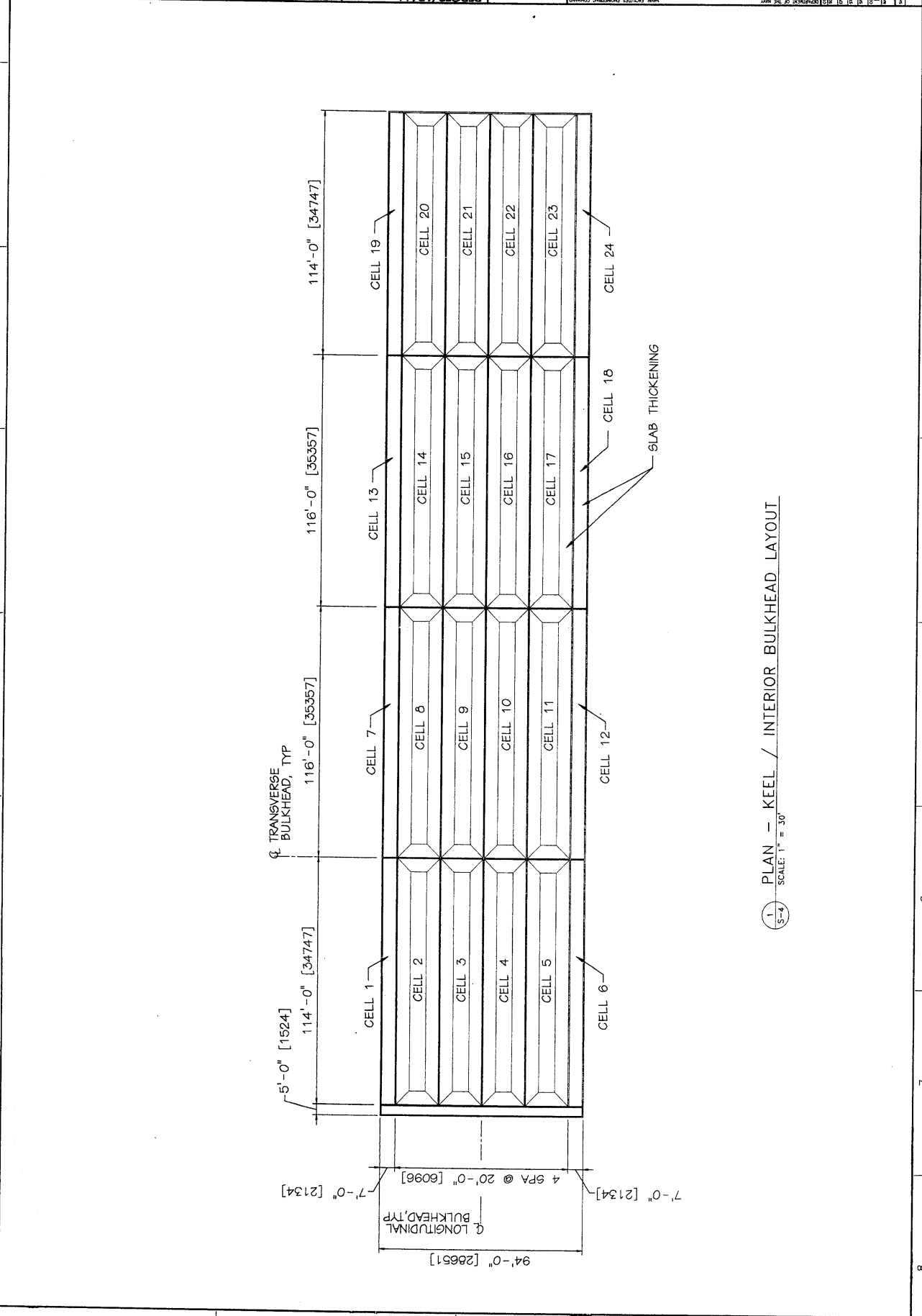
NO.	DATE	DESCRIPTION

DESIGN NO.	
PROJECT NO.	
DATE	
BY	
CHECKED	
APPROVED	

BERGER/ABRAM  
 11000 17th Street, Suite 100  
 San Diego, CA 92161  
 (619) 594-9900

NAVAL STATION  
 MODULAR HYBRID PIER  
 FLOATING PIER  
 KEEL / INTERIOR BULKHEAD LAYOUT

DATE: 02/10/09  
 DRAWING NO.: C-70209  
 SHEET NO.: 1  
 TOTAL SHEETS: 4



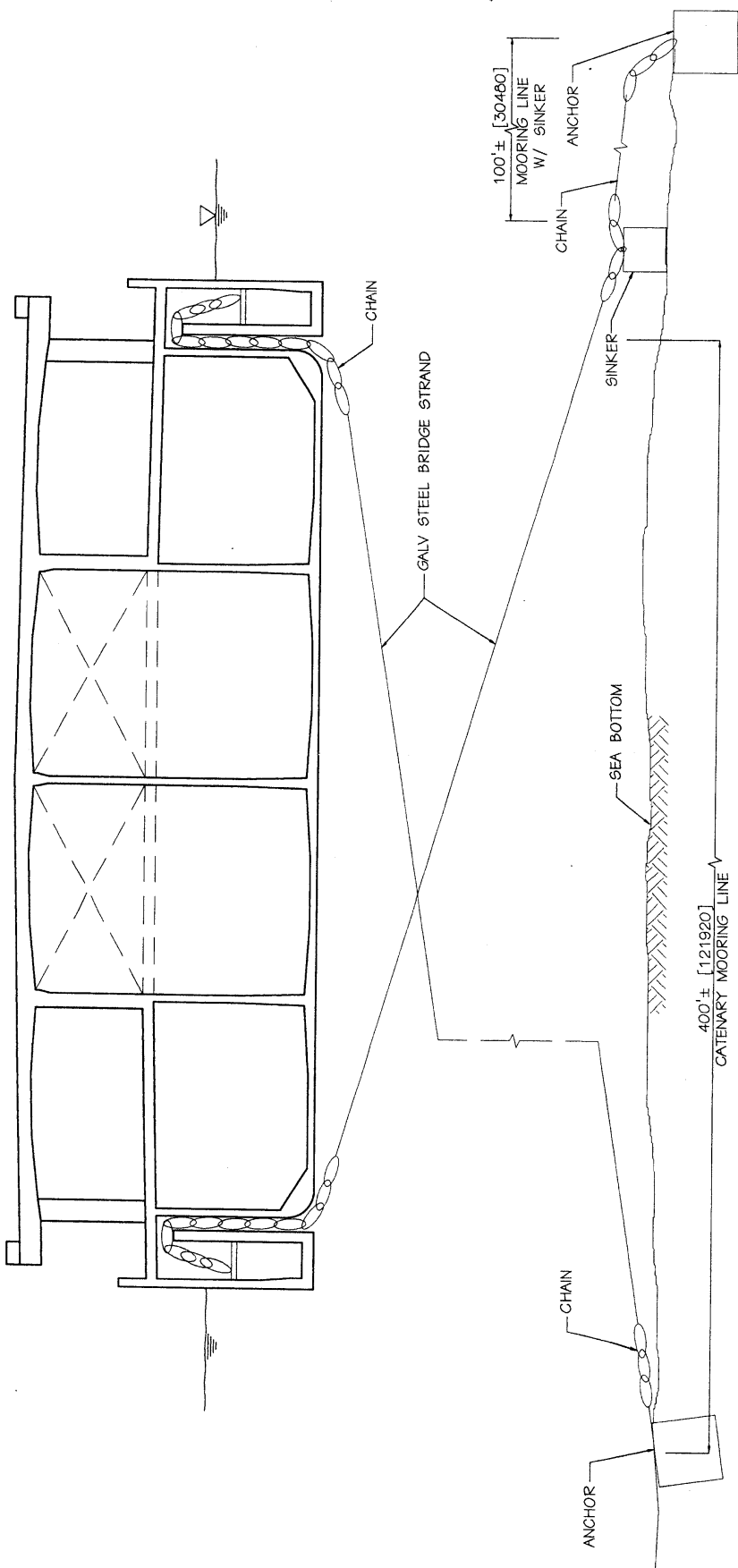
PLAN - KEEL / INTERIOR BULKHEAD LAYOUT  
 SCALE: 1" = 30'

1 2 3 4 5 6 7 8



REVISIONS		DESIGN SECTION		DATE		BY		CHECKED		APPROVED	

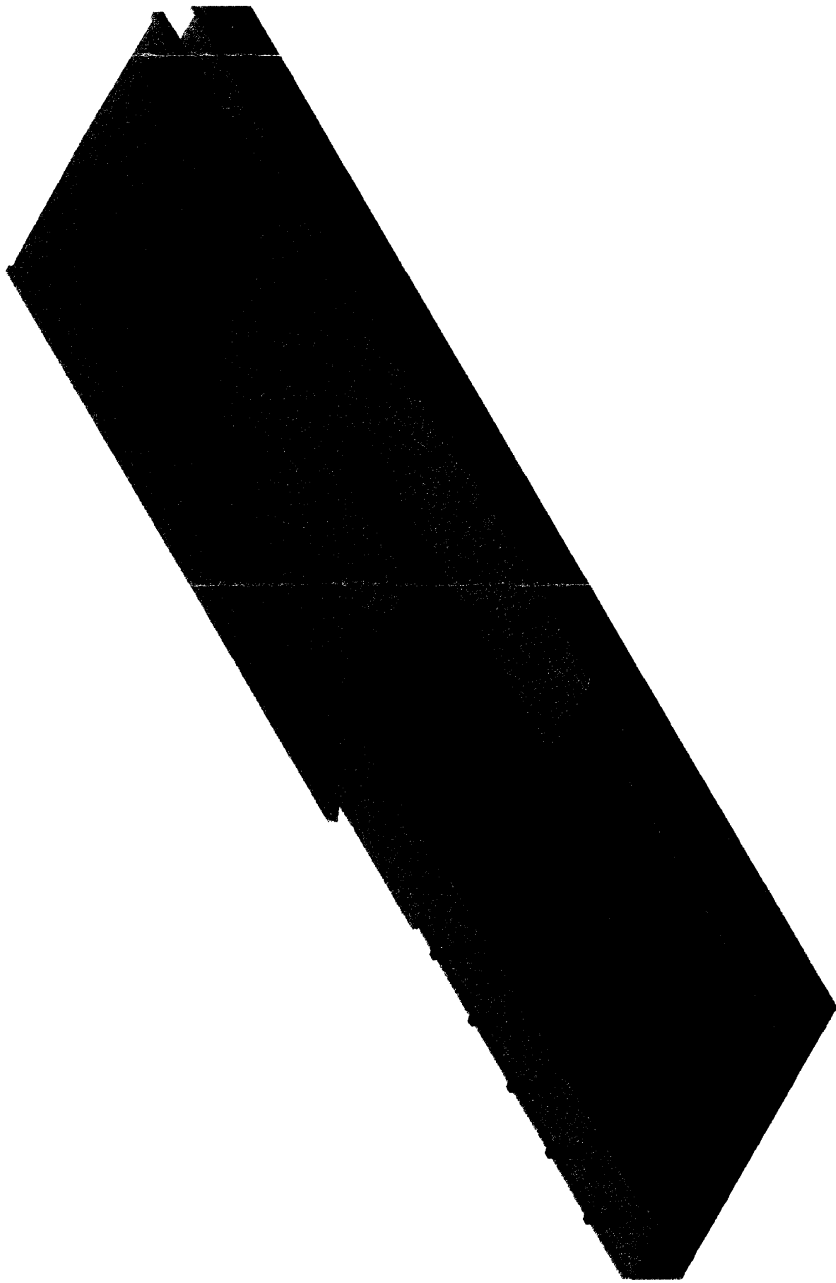
PROJECT: BERGER/ABRAM  
 TITLE: MOORING LINE ARRANGEMENT OPTIONS  
 DRAWING NO.: 121920  
 SHEET NO.: S-5  
 SCALE: 1" = 5'  
 DATE: 12/19/20  
 DRAWN BY: [Name]  
 CHECKED BY: [Name]  
 APPROVED BY: [Name]



SECTION - MOORING LINE ARRANGEMENT OPTIONS  
 SCALE: 1" = 5'

1 2 3 4 5 6 7 8

ISOMETRIC - PONTOON FRAMING



REVIZIJSKI LIST	
№	OPIS
1	IZVOD
2	IZVOD
3	IZVOD
4	IZVOD
5	IZVOD
6	IZVOD
7	IZVOD
8	IZVOD
9	IZVOD
10	IZVOD
11	IZVOD
12	IZVOD
13	IZVOD
14	IZVOD
15	IZVOD
16	IZVOD
17	IZVOD
18	IZVOD
19	IZVOD
20	IZVOD
21	IZVOD
22	IZVOD
23	IZVOD
24	IZVOD
25	IZVOD
26	IZVOD
27	IZVOD
28	IZVOD
29	IZVOD
30	IZVOD
31	IZVOD
32	IZVOD
33	IZVOD
34	IZVOD
35	IZVOD
36	IZVOD
37	IZVOD
38	IZVOD
39	IZVOD
40	IZVOD
41	IZVOD
42	IZVOD
43	IZVOD
44	IZVOD
45	IZVOD
46	IZVOD
47	IZVOD
48	IZVOD
49	IZVOD
50	IZVOD
51	IZVOD
52	IZVOD
53	IZVOD
54	IZVOD
55	IZVOD
56	IZVOD
57	IZVOD
58	IZVOD
59	IZVOD
60	IZVOD
61	IZVOD
62	IZVOD
63	IZVOD
64	IZVOD
65	IZVOD
66	IZVOD
67	IZVOD
68	IZVOD
69	IZVOD
70	IZVOD
71	IZVOD
72	IZVOD
73	IZVOD
74	IZVOD
75	IZVOD
76	IZVOD
77	IZVOD
78	IZVOD
79	IZVOD
80	IZVOD
81	IZVOD
82	IZVOD
83	IZVOD
84	IZVOD
85	IZVOD
86	IZVOD
87	IZVOD
88	IZVOD
89	IZVOD
90	IZVOD
91	IZVOD
92	IZVOD
93	IZVOD
94	IZVOD
95	IZVOD
96	IZVOD
97	IZVOD
98	IZVOD
99	IZVOD
100	IZVOD

1 2 3 4 5 6 7 8

A B C D

ISOMETRIC  
MODULNA HRBID PIER  
NAMSTA NOKHOLK PIER 2 VE PROPOBAL

REVISIONS

**Meeting Minutes**  
24 September 1998  
**FRP/Concrete Hybrid Pier Project**  
Ben C. Gerwick Offices  
San Francisco, CA

**1. Introduction**

**Team members**

George Warren	805-982-1236	<a href="mailto:warrenge@nfesc.navy.mil">warrenge@nfesc.navy.mil</a>
Bob Odello	805-982-1237	<a href="mailto:odellorj@nfesc.navy.mil">odellorj@nfesc.navy.mil</a>
David Hoy	805-982-1062	<a href="mailto:hoyde@nfesc.navy.mil">hoyde@nfesc.navy.mil</a>
Steve Harwell	805-982-1269	<a href="mailto:harwellsa@nfesc.navy.mil">harwellsa@nfesc.navy.mil</a>
Chris Inaba	805-982-1261	<a href="mailto:inabacm@nfesc.navy.mil">inabacm@nfesc.navy.mil</a>
Manfred Zinserling	206-431-2300	<a href="mailto:zinserling@abam.com">zinserling@abam.com</a>
Mike Lanier	206-431-2300	<a href="mailto:lanier@abam.com">lanier@abam.com</a>
Bob Mast	206-431-2300	<a href="mailto:mast@abam.com">mast@abam.com</a>
Charlie Dolan	307-766-2857	<a href="mailto:cdolan@uwyo.edu">cdolan@uwyo.edu</a>
George Fotinos	415-398-8972	<a href="mailto:gcf@gerwick.com">gcf@gerwick.com</a>
Dale Berner	415-398-8972	<a href="mailto:deb@gerwick.com">deb@gerwick.com</a>
Sam Yao	415-398-8972	<a href="mailto:sy@gerwick.com">sy@gerwick.com</a>
Paul Bach (part time)	415-398-8972	<a href="mailto:peb@gerwick.com">peb@gerwick.com</a>

The agenda for this kickoff meeting has been distributed in advance and consisted of the following:

- Introduction
  - Team members
  - Interests of other stake holders
- Team mission statement
- Phase I Approach and Deliverable
- Phases II, III, and MILCON 2004
- Site Characterization
- Fixed or floating pier
- How do other stakeholders want to be involved?

**Applicable background**

The project is funded by ONR through NFESC. The Phase I project will be reviewed and considered for extension based on the findings of the Phase I effort. The final objective is development of a FRP/concrete hybrid pier for MILCON 2004.

## **Interests of other stakeholders**

ISIS CANADA – NFESC is interested in input from ISIS on structural sensor strategy applicable to this project.

Composite Institute – A representative of the group was not able to attend the kickoff meeting. The collaboration agreement between the Navy and the Composites Institute was explained. Initial contact with this group will be through Bob Odello.

SACMA and The Great Lakes Composites Consortium may also be interested in the results of this work. NFESC will handle any initial contacts necessary.

Other interested stakeholders include PACFLEET, LANTFLEET, NAVSHIPS, and NAVFAC LANTDIV. NFESC will handle contacts with these entities.

## **2. Team Mission Statement**

The following mission statement was presented for discussion:

“Operational FRP/Concrete composite pier for MILCON 2004”

This study shall be a showcase of the benefits of composite hybrid pier structures.

It was stated that fendering design will be the responsibility of NFESC.

One objective is to develop a project that showcases the benefits of composite hybrid pier structures.

## **3. Phase I Approach and Deliverable**

The approach and deliverable for Phase I are as outlined in the proposal and supplemented by the task breakdown of the fee proposal provided to NFESC.

It was requested that the team carry both fixed and floating pier concepts through Phase I. The team requested that this decision be made in November 1998 on the basis of background comparison work the team will prepare.

The content of Phases II, III, and any MILCON 2004 work will be mutually agreed with NFESC in advance of the start of each Phase, assuming the project proceeds beyond Phase I.

## **4. Site Characterization**

### **Functional and Operational Requirements/Constraints**

NFESC presented five exhibits from a presentation made to promote this project within the Navy.

The sheets outlined:

Technical goals

Design features  
Hybrid pier design requirements  
Technical concept of a FRP/concrete berthing pier  
Cost breakdown MILCON P327 NAVSTA San Diego

A clear deck is set as a primary goal.

Double deck or not, the pier must have a clear deck with 25,000 ft<sup>2</sup> for Phase Maintenance activities. MIL-HDBK-1025.1 is the standard for determining functional program for the pier.

Minimum on-site construction and little cast-in-place concrete construction in order to minimize environmental impact.

Off-site prefabrication of concrete components/structures, perhaps at a central Navy facility, is a sound idea.

Reconfiguration of pier to accommodate new technology should be one of the design considerations, but relocation from one site to another is not a design requirement.

Overall structural performance is a more important consideration than micro material performance. Selection of materials and structural concepts should be based on performance characteristics required for successful performance of the structures involved.

### **Cost Goals**

The cost target for the initial prototype facility is 1.2 times the cost of conventional pier structures or less. A current cost estimate based on the replacement pier MILCON P-327 NAVSTA San Diego (\$53M) was presented for discussion. It was noted that the pier structure was about 30 to 35 percent of the overall project cost.

The capital cost is a major concern in determining the pier type. In a 1980's study, a floating pier concept was abandoned in favor of a fixed pier due to a small cost difference, despite numerous advantages associated with the floating pier concept.

Navy cost analysis methodology is heavily weighted in favor of low first cost and does not provide substantial credit to operational and life cycle cost reductions.

### **Other Requirements Discussed**

Design for nested vessels 2 deep.

Modulation is a design requirement that is driven by capability to reconfigure the pier to accommodate new technology and to make rapid repairs after damage. Relocation is a

feature that may be inherent to modularity but should not be a primary driver of the design.

Fire protection.

Effects of high temperature during steam curing of precast concrete elements and some service conditions.

Basically no maintenance and no inspection of the pier during the design service life.

Because of past experiences, fiberglass under stress in concrete should be minimized.

Handrails and gratings and other secondary structural elements should exploit fiberglass.

Consideration should be given to the future communication system requirements, and to Navy plans for future use of steam lines and salt water lines.

Design criteria for FRP/Concrete hybrid: reference to Japanese design guidelines, European design guidelines, Canadian design recommendations.

Rapid repair of impact damage – take advantage of modular construction.

Protection against sabotage and terrorists' attacks.

Minimum downtime of existing facilities during the pier construction (however, it was noted that a cost benefit is not assigned to this).

Currently, NFESC is undertaking the investigation of methods to allow the detection of structural problems in advance of the requirement for costly maintenance and repair.

It was discussed that most embedded sensors have much shorter life spans than the service life of the structures. The team will look into sensor strategy most appropriate to the type of pier structure selected.

## **5. Fixed or Floating Pier**

A listing of items to consider in the fixed versus floating decision was presented and discussed. NFESC indicated they would review this listing and provide any input they had.

The team will make a preliminary recommendation on the pier type by Nov. 10.

The overall facility cost is the governing issue in the selection of the pier type.

The maintenance and operational constraints should be factored in the selection process. The first step is to identify 4 to 5 issues that have often caused maintenance and

operational problems in conventional piers. Then, consider the advantages and disadvantages of the fixed and floating pier in solving these problems.

The cost of piers is, in general, site-specific, i.e., the site characteristics can have a significant effect on the cost of a fixed pier while they have less effect on the cost of a floating pier.

Precast concrete fabrication considerations should be factored into cost consideration. Land space on most Navy bases is at a premium. Consideration may be given to fabrication on barges, or a permanent graving dock for precast concrete fabrication of several piers.

Design criteria: reference to Japanese design guidelines, European design guidelines, Canadian design recommendations.

#### **6. How do other stakeholders want to be involved?**

NFESC will handle involvement of other Navy entities at the appropriate time.

#### **7. Next Step**

- Meeting minutes by Sept. 28-29
- By No. 10, the team will have a position paper on the issue of fixed versus floating pier for presentation to NFESC.
- Team will begin to develop appropriate conceptual configurations of fixed and floating piers.
- Team will begin to identify the common issues that have often caused maintenance and operational problems.
- Team will start preliminary study of structural elements: proper materials for typical structural components, how to use them, and where to use them.

Please contact Mike LaNier at [lanier@abam.com](mailto:lanier@abam.com) if you have revisions to these minutes.

**NEFC FRP/Concrete Composite Hybrid Pier Project  
Meeting with Representatives of Composites Institute**

Thursday, December 17, 1998 - 9:30 AM  
BERGER/ABAM Offices  
33301 Ninth Avenue South - Third Floor  
Federal Way, WA 98003  
206-431-2300

We are expecting out of town participants for this meeting to arrive at our offices between 9:00 and 10:00 AM as there are some attendees who will be arriving by plane the morning of the meeting. We will start the meeting with introductions and the mission of the FRP/Concrete Hybrid pier project at 9:30 with the idea that the core aspects of the meeting will begin around 10:00 AM.

**Objectives for meeting:**

1. Provide Composites Institute enough information about the FRP/Concrete Hybrid pier program so that they can assess the most effective ways to interact with the development of the project concepts.
2. Provide an opportunity for the design team to learn the types of resources available from members of the Composites Institute.
3. Identify the range of possible applications for FRP products in the development of the FRP/Concrete Hybrid pier.
4. Determine the availability and or extent of development work necessary to provide products suited for use in the FRP/Concrete Hybrid pier.
5. Define viable methods of determining the costs associated with different FRP products to be used in the FRP/Concrete Hybrid pier.
6. Outline an interaction program among the Navy, the Design Team and the Composites Institute membership for the remainder of the FRP/Concrete Hybrid pier design effort.



**Meeting Agenda**  
**NEFC FRP/Concrete Composite Hybrid Pier Project**  
**Meeting with Representatives of Composites Institute**

Introductions	All
Mission of the FRP/Concrete Composite Hybrid Pier Project	BERGER/ABAM
Interest of the Composites Institute in this project	Composites Institute
Explanation of the current concept and development process	BERGER/ABAM
Discussion of best sources of reliable design materials property information	All
Review of preliminary listing of areas and features that are candidates for FRP Composite use	List by BERGER/ABAM Review by All
Discussion of quantities required and timing of needs	BERGER/ABAM
Discussion of development tasks necessary Prestressing systems Mesh reinforcement	All
Discussion of how to get best FRP cost and availability information	All
Discussion of best ways to interact with Composites Institute and take advantage of experience and capabilities	All
Next Step	BERGER/ABAM
Other items	
Adjourn	

**Meeting Minutes**  
17 December 1998  
**FRP/Concrete Hybrid Pier Project**  
**Design Team/Composites Institute**  
**Initial Introduction Meeting**  
BERGER/ABAM Engineers Inc.  
Offices

**1. Introduction**

**People present**

George Warren - NFESC	805-982-1236	<a href="mailto:warrenge@nfesc.navy.mil">warrenge@nfesc.navy.mil</a>
Doug Barno – Composites Institute	614-587-1444	<a href="mailto:dbarno@socplas.org">dbarno@socplas.org</a>
Mike Guglielmo – Composites Inst.	408-297-9300	<a href="mailto:mike@glasforms.com">mike@glasforms.com</a>
Yanqiang Gao – BERGER/ABAM	206-431-2300	<a href="mailto:gao@abam.com">gao@abam.com</a>
Mike LaNier – BERGER/ABAM	206-431-2300	<a href="mailto:lanier@abam.com">lanier@abam.com</a>
Bob Mast – BERGER/ABAM	206-431-2300	<a href="mailto:mast@abam.com">mast@abam.com</a>

Mr. Barno and Mr. Guglielmo participated in the meeting on behalf of the Composites Institute.

**2. Agenda**

The meeting objectives and agenda for this meeting had been distributed in advance and are attached to these minutes as reference.

**3. Discussion**

Mr. Barno made a presentation of the activities and make-up of the Composites Institute and indicated the type and range of supporting service that their membership could provide to the FRP/Concrete composite pier project. The Market Development Alliance is a subset of the Composites Institute that involves 30 member companies.

It was pointed out that the focus on use of composites in civil infrastructure has been increasing since the early 1990's.

BERGER/ABAM, with input from Dr. Warren, outlined the mission of the initial phase of the FRP/Concrete Composite Pier project. It was pointed out that the potential for subsequent phases of these efforts depends primarily on favorable results from the initial phase.

It was stated that the best source of design materials property information at this stage will likely result from our collaboration with Dr. Dolan at the University of Wyoming.

The group reviewed a list of candidate areas for use of FRP materials in a floating Navy pier. A copy of this listing with annotations is presented in Appendix F. The

Composites Institute representatives will assist the design team in getting vendor information on the items noted for this action in the attached list.

The following listing of rough guidelines for material costs were given by the members of the Composites Institute:

Bridge decks installed (HS20 Loading)	\$70 to \$100 per square foot of deck
Engineered products requiring engineering for each application.	
Standard structural elements (GFRP)	\$2.50 per pound
This includes tubes, channels, and structural shapes.	
Rods with unidirectional fibers (GFRP)	\$2.00 per pound
In quantities exceeding 3000 pounds	
Unique structural elements (GFRP)	\$3.50 per pound
Engineered to optimize element	
Custom hatch covers (GFRP)	\$5.00 per pound.
Deformed carbon prestressing tendons (smooth tendons 25% less)	\$70.00* per pound
Flat strip tendons using Zoltec carbon	\$20.00* per pound

\*Additional discussion and definition of product requirements will be required to verify preliminary costs for carbon fiber prestressing tendons and carbon fiber mesh suited for concrete reinforcement.

A very preliminary listing of quantities of prestressing tendon material and reinforcing mesh material that would be required for a Navy floating pier prestressed and reinforced with carbon fiber materials was presented by BERGER/ABAM for purposes of discussion of availability and likely development and production lead time.

It was agreed that the design team would make any information and input requests through Mr. Barno who will direct the inquiries to the appropriate members of the Composites Institute.

**ACTION:**

BERGER/ABAM to follow up meeting with an annotated list of areas that could take advantage of FRP composites to Mr. Barno with a request for specific product input.

BERGER/ABAM to send Dr. Warren our published data on lightweight marine quality concrete.

Composites Institute – Mr. Barno to assist in securing information as listed in attached list of application areas.

Composites Institute - Mr. Barno to contact SNETEF for applicable development work.

Composites Institute – Mr. Barno to supply contact name in NAVSEA for durability database.

**AGENDA**  
**4 MARCH 1999**  
**BERGER/ABAM OFFICES**  
**FEDERAL WAY, WASHINGTON**

1. **Introduction**
2. **Agenda**
3. **Cost Evaluation**  
Cost analysis  
Hybrid concept versus all steel and all carbon
4. **Meetings with Toray Industries**  
Toray visit  
MegaFloat visit
5. **Construction Issues**  
Piling/mooring system  
Typical details — pontoon sections  
Pontoon hydrostatics  
LTWT concrete durability  
Crack width — How does material behave? Is this satisfactory?
6. **Phase I - Final Report**  
Is normal B/A format acceptable?  
CI-MDA has not delivered yet !  
Dr. Dolan's testing is behind schedule  
Develop Cost Targets
7. **Phase 2 Proposal**  
Proposed Tasks  
Discussion
8. **Other Issues**  
Schedule to complete

**Adjourn**

**MEETING MINUTES  
4 MARCH 1999**

**MODULAR HYBRID PIER PROJECT  
BERGER/ABAM OFFICES  
FEDERAL WAY, WASHINGTON**

**1. INTRODUCTION**

**Team Members**

George Warren	805/982-1236	<a href="mailto:warrenge@nfesc.navy.mil">warrenge@nfesc.navy.mil</a>
George Fotinos	415/398-8972	<a href="mailto:gcf@gerwick.com">gcf@gerwick.com</a>
Sam Yao	415/398-8972	<a href="mailto:sy@gerwick.com">sy@gerwick.com</a>
Bob Mast	206/431-2300	<a href="mailto:mast@abam.com">mast@abam.com</a>
Mike LaNier	206/431-2300	<a href="mailto:lanier@abam.com">lanier@abam.com</a>
Manfred Zinserling	206/431-2300	<a href="mailto:zinslerling@abam.com">zinslerling@abam.com</a>

**2. AGENDA**

The agenda for this meeting was distributed. See attachment.

**3. COST EVALUATION**

The latest version of the memorandum "Design of CFRP-Reinforced Sections" was distributed. Crack width design recommendations are not proposed at this time. It appears that an (arbitrary) maximum strain of 0.0024 in the CFRP near the surface will result in crack widths on the order of 0.1 mm. Further testing should be conducted to verify the effectiveness of grid/mesh reinforcement in controlling crack widths and crack distribution. Crack penetration (depth through the cross section) also needs to be evaluated as this might affect design of the corrosion protection of the prestressing steel.

**Action:** Team to propose a crack width design philosophy for the final report.

Typical reinforcing details for the floating structure were presented and discussed. A cost comparison for a flat slab element is presented in Table 7 of the memo. The comparison only includes concrete, mild steel reinforcement, carbon reinforcement, and steel prestress material costs but not installation costs (formwork, stressing, etc.). Three concepts are presented.

- a. All carbon reinforced cross section consisting of carbon fiber mesh and carbon prestressing reinforcement
- b. All steel reinforced cross-section consisting of mild steel reinforcement and steel prestressing strand]
- c. A hybrid system consisting of steel prestressing strand and carbon fiber mesh

Other assumptions used in the cost comparison.

- a. All mild steel reinforcement was epoxy coated.
- b. Encapsulated steel prestressing tendons were used.
- c. Carbon composite price of \$20 per pound was used.
- d. All steel system designed for "0" tension, hybrid, or all composite systems not limited by "0" tension criteria.
- e. Strain of 0.0024 was used for carbon mesh materials.

The hybrid system appears to be the lowest cost solution for a given service level moment.

**Action:** Team to proceed with development of hybrid system.

#### 4. MEETINGS WITH TORAY INDUSTRIES

BERGER/ABAM has had several meetings with Toray Industries, locally in Seattle and in Japan, to discuss the feasibility of producing mesh fabric using carbon fiber material. Toray provided samples of some of their woven carbon fiber product, raw carbon fiber mesh (dry mesh), and composite carbon fiber mesh.

Weaving technology presently limits strand spacing to 20 to 22 mm for 7k to 12k tow materials. The team's desire is to obtain 25 mm or greater spacing because of the greater tow size required (48k up to 160k or more). Toray will investigate possibility of using greater spacing.

The carbon fiber industry continues to evolve. New products are being produced with improved properties but at lower cost than earlier materials. Carbon fiber prices are in the range of \$8 per pound. Carbon composite prices will be higher and depend on the type of binder (matrix) material. There are many grades of epoxy and the price varies considerably. A target price of \$20 per pound for carbon composite mesh should be attainable.

The carbon fiber industry is apparently entering a period of oversupply/excess capacity because of the shrinking demand from the aerospace industry, new companies entering the business, and existing firms improving plant and equipment. These events could drive the price for carbon fiber down.

Toray is very interested in promoting carbon fiber composites within the civil/structural construction industry. Toray is willing to provide carbon mesh materials for testing in this program.

Field fabrication of composite mesh was discussed. This would be similar to the process used to wrap columns for seismic strengthening. Dry mesh (and prepreg) material is very flexible and easy to coil and hence transport whereas the composite material is very stiff. Further investigation is required into the possibility of shipping material in a dry mesh or prepreg condition and then using a field impregnator machine to produce the composite. There are major benefits to this method: the material is easier to ship and handle and it can be field fabricated to fit the construction.

**Action:** Team participants to develop needs and requirements for carbon mesh to be used in future testing program (Phase 2).

## 5. CONSTRUCTION ISSUES

### Pile Dolphin Mooring System for Floating Dock

Proposed mooring system consists of pile-supported mooring dolphins at each end of the floating dock. Intermediate piles may also be required.

Connection between mooring dolphin and floating dock needs to use proven technologies.

**Action:** Investigate anchor line mooring and document mooring system design.

## 6. LIGHTWEIGHT CONCRETE

Propose to use sand lightweight concrete with design strengths of 7 to 8 ksi. Team will review recent CalTrans experience with lightweight concrete. Have not been able to document experience of self-compacting lightweight concrete, e.g., use of Viscocrete, or similar, with lightweight aggregates. Will need to be demonstrated in the next phase of this program.

**Action:** Provide lightweight concrete mix design that meets desired qualities. List durability parameters for lightweight concrete.

## 7. PHASE 2 PROPOSAL

Presented outline of testing for Phase 2. Phase 2 may be different than was originally planned. NFESC would like to divide testing into several parts – testing that could be undertaken by NFESC and other contract labs in the interim, Phase 1A, between Phase 1 and notice to proceed for Phase 2. NFESC will take responsibility for testing CRFP prestress tendons, possibly do some fatigue testing. NFESC would like to see results from University of Wyoming testing program on GFRP grids before committing to additional testing.

**Action:** Additional basic materials research and testing required. Revise proposed testing program for Phase 2. NFESC desires to proceed with in-house testing or use existing contractors to perform testing in the interim, Phase 1A, between Phases 1 and 2.

## 8. OTHER ISSUES

A revised Table 1 showing cost comparison between MILCON P-327 NAVSTA San Diego and several other recent MILCON projects was presented. A column with a proposed target cost for a floating concrete hybrid pier was presented. The cost target for the initial prototype facility is 1.2 times the cost of conventional pier structures or less. It was noted that the pier structure was about 30 to 35 percent of the overall project cost. One of the key technical issues is the production of the carbon fiber mesh.

**Action:** Team to contact Mike Guglielmo and Goldsworthy regarding manufacture of mesh.

Please contact Manfred Zinserling at [zinslerling@abam.com](mailto:zinslerling@abam.com) if you have revisions to these minutes.



**NEFC Modular Hybrid Pier Project  
Meeting with Representatives of NFESC  
Agenda**

Wednesday 28 July 1999  
BERGER/ABAM Offices  
33301 Ninth Avenue South - Third Floor  
Federal Way, WA 98003  
206-431-2300

**Background**

Phase 1 of the project involved six primary areas of effort:

1. Recommend fixed vs. floating pier
2. Preliminary floating pier configuration recommendation
3. Evaluation of appropriate use of FRP technology in a floating pier
  - Relative maturity of available technologies (near term MILCON)
  - Primary structure use
  - Secondary structure and appurtenance use
4. Identification of applicable structural concepts
5. Development of a design philosophy/criteria for selected structural concept
6. Definition of follow-on Phase 1A and 2 work

**Objectives for meeting:**

1. Discuss the overall hybrid modular floating pier concept and the structural requirements of the critical pier elements.
2. Identify the range of possible applications for FRP products in the development of the FRP/concrete hybrid modular pier.
3. Determine the availability and or extent of development work necessary to provide products suited for use in the FRP/Concrete hybrid modular pier.
4. Discuss the conclusions from the assessment of appropriate ways to use FRP technology for the development of the FRP/Concrete hybrid modular pier
5. Discuss what we feel requires confirmation by test. (The total testing program)
6. Discuss why we have proposed the Phase 1A test program that has been proposed.
7. Outline an interaction program among the Navy, the Design Team and the Composites Institute membership for the Phase 1A FRP/concrete hybrid modular pier design effort.
8. Agree on the scope of work and level of effort for the Phase 1A effort.

**Meeting Agenda**  
**NEFC FRP/Concrete Composite Hybrid Pier Project**  
**Meeting with Representatives of Composites Institute**

Introductions	All
Mission of the FRP/Concrete Composite Hybrid Pier Project	BERGER/ABAM
Interest of the Composites Institute in this project	Composites Institute
Explanation of the current concept and development process	BERGER/ABAM
Discussion of best sources of reliable design materials property information	All
Review of preliminary listing of areas and features that are candidates for FRP Composite use	List by BERGER/ABAM Review by All
Discussion of quantities required and timing of needs	BERGER/ABAM
Discussion of development tasks necessary Prestressing systems Mesh reinforcement	All
Discussion of how to get best FRP cost and availability information	All
Discussion of best ways to interact with Composites Institute and take advantage of experience and capabilities	All
Next Step	BERGER/ABAM
Other items	
Adjourn	

## Construction of the Confederation Bridge

This appendix provides a description of the Confederation Bridge project as background for the offsite prefabrication of large, long span precast concrete modules concept for the double deck Navy pier.

Construction of the Confederation Bridge, or the so-called Prince Edward Island Bridge, over the Northumberland Strait in Canada was a two-year design-build project. In many ways, the project represents the state-of-the-art in offsite fabrication and segmental launching of concrete bridges. The concept and construction techniques used in the project have significant implications in modern precast concrete construction of large civil work projects.

The Confederation Bridge consists of an 11.0-km long main bridge and 1.9-km of approach bridges (see Figure 1). The main bridge consists of a box girder bridge deck resting on 44 precast concrete piers. The pier structure is a gravity-based foundation on bedrock. The piers stand in over 35-m water depths and support the box girder bridge deck that spans 250-m between piers. The box girder superstructure provided a passageway and a utility room from one end of the bridge to the other.

The overriding concern in the project was the severe and unpredictable weather conditions at the bridge site. The winter storms, blizzards, and ice floes across the Northumberland Strait greatly restricted the onsite construction window and made overwater construction very difficult. Figure 2 illustrates an ice floe around the bridge piers, this condition exists throughout the winter season.

As a result, the winning design was a prestressed concrete box girder bridge that was entirely prefabricated offsite and segmentally constructed onsite. The box girder structure provides the most reliable structural performance against a progressive collapse failure under the severe environment. The offsite fabrication allows the minimum onsite construction and more effective quality control.

All the bridge components are made of reinforced high-strength concrete, totaling 478,000 cubic meter in volume. Figures 3(a), 3(b) and 4 show a set of prefabricated main bridge sections and how those sections are fitted together. These bridge components were fabricated in a 165-acre precast concrete yard. The large main bridge components – main girders, drop-in girders, pier shafts, and pier bases – were built atop 2.4 to 5.5-m high concrete pillars. Figure 5 shows the concrete pillars and some of the 6000 meters of skidway that would eventually be installed.

Pier bases were not cast all at one time, but in four separate casting operations. First the bottom (footing) ring was cast, then the cone, next the cylinder (barrel), and finally the top stump segment (See Figure 4 for definitions). Sectionalized forms allowed the components to be cast from the bottom ring up in this segment-by-segment method. Figure 6 shows

three production lines for pier base fabrication, and pier bases at different stages in the casting process.

Pier shafts were cast in two stages. First, the lower ice shield portion was cast, then the pier shaft. The ice shield is a conical structure 20 meters in diameter at its base. The cone is 13 meters high. Its purpose is to reduce the ice force against the bridge piers (See Figure 4 for definitions).

With a length of 192 meters and a weight of 7500 tonnes, the main girder is by far the largest and heaviest component. It is also the most involved piece to cast. Constructing a main girder started with the hammerhead section. It is a steel-concrete composite section that would be the anchoring point for many of the post-tensioning tendons that tie the main girder to the pier shaft and drop-in girders. Once the hammerhead has been completed, it is moved to the next position in the production line and a new girder segment is cast at each end of the hammerhead. That assembly is then moved to the next position, and two more segments are added. This cycle repeats itself until eight segments are added to each side of the hammerhead. Then, the girder is moved to the storage area where a special segment is added that will connect to the hinged drop-in girder. Figures 7(a), 7(b) and 8 illustrate the different stages of construction of the main girders in the yard.

Figure 3 shows the drop-in girders, and how they connect one main girder to the next. There are two types of connection – the continuous connection and the hinged connection. The continuous connection requires a closure pour to make it a one-piece structure. The hinged drop-in girder rests on fixed bearings at one end and sliding bearings on the other. The sliding bearings allow the bridge to expand and contract freely.

All the main bridge components were built atop high concrete pillars. A two-track concrete skidway, upon which a Huisman sledge would slide, was built between sets of pillars. To move a concrete component, a Huisman would travel down the skidway until it was directly under the component. Jacks on the sledge would raise the component a few centimeters off its supporting pillars. The sledge would then crawl down the track, carrying the component to the next work station or to the storage area. Loading out these precast components is through a 500 meter long jetty to accommodate a heavy lift vessel - Svanen.

Svanen is a 103-m long, 72-m wide, and 102-m tall catamaran used to transport and place main bridge components. The vessel was purchased in Europe and modified to accommodate the heavy lifting for the project. The lift capacity was increased from 7000 tonnes to 8500 tonnes.

The major onsite marine work involved dredging and placement of precast segments. Figure 9 shows the Svanen approaching the jetty to pick up a pier base from atop a Huisman sledge. The Svanen then traveled to the bridge site and was anchored firmly into position with 8 pre-set anchors. After final positioning, guided by GPS, the pier base was lowered down to set on three pre-set hard points. Picking up and placing pier shafts and special, match-cast templates to set the main girders upon, was similar to that of pier bases, except

that the pier shaft was not set directly onto the pier base. The two pieces were held slightly apart by jacks. The narrow space between the components was later filled with grout, creating a solid, load-bearing connection.

Lifting and placing the 7500 tonnes main girders required special care. Energy absorbers were used to control the lowering of the girders. Figure 10 shows the Svanen placing Main Girder 22 at the halfway point across the main bridge.

The placement of these main bridge components was followed by extensive post-tensioning operations. Post-tensioning was used to tie main girders to pier shafts, pier shafts to pier bases, and continuous drop-in girders to the main girders on either side.

The entire project formally started on October 3, 1993 when Strait Crossing Development, Inc. and the Canadian government signed an agreement to build the bridge as a BOT project.

By the end of 1994, the 165-acre Amherst Point farm had been turned into a first-class precast yard and over 12,000 design/shop drawings were produced. Some schedule highlights are as follows:

- The first pier base was constructed on May 4, and placed underwater on August 7, 1995;
- The first pier shaft was constructed on June 3, and placed on August 23, 1995;
- The first main girder was constructed on August 9, and placed on October 1, 1995;
- The first drop-in girder was constructed on June 23, and placed on November 17, 1995.
- Prefabrication of the bridge components was carried out throughout the winter season of 1995-1996.
- Placement of the bridge components was resumed on April 20, 1996.
- On November 19, 1996, the Svanen placed the last structural component – the drop-in girder between pier 34 and 35. (Figure 11)
- On May 30, 1997, the Confederation Bridge was formally opened to traffic.

Ben C. Gerwick, Inc. was involved throughout the above project, first as a subconsultant to J. Muller International, the designer, and then as an engineering representative of Morrison-Knudson, the prime contractor, to provide onsite technical support.

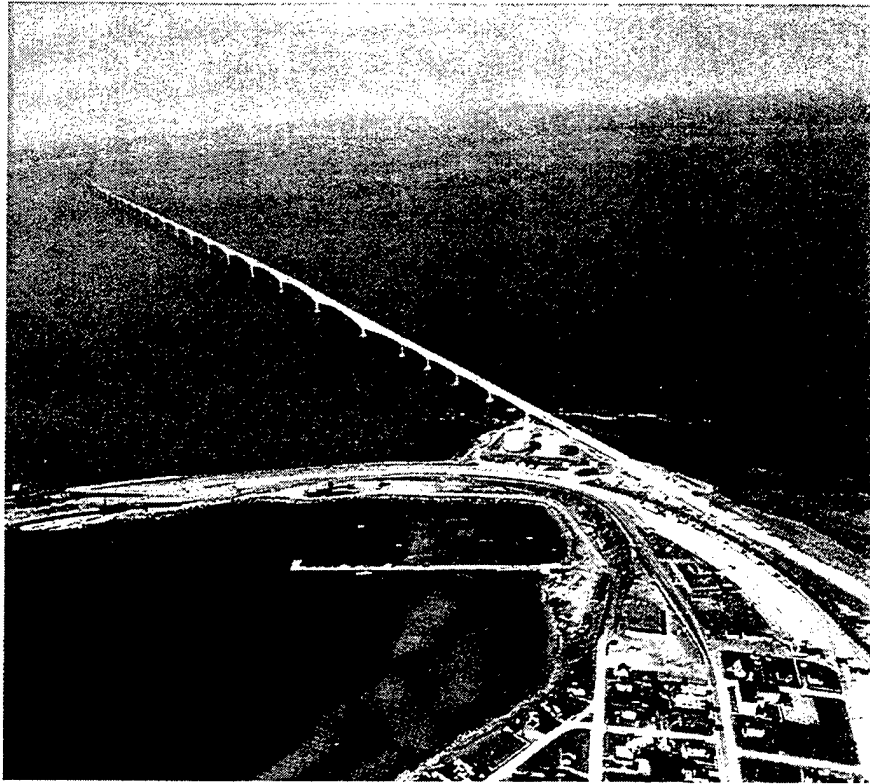


Figure 1 The Confederation Bridge across the Northumberland Strait



Figure 2 Ice Forming around the Bridge Pier

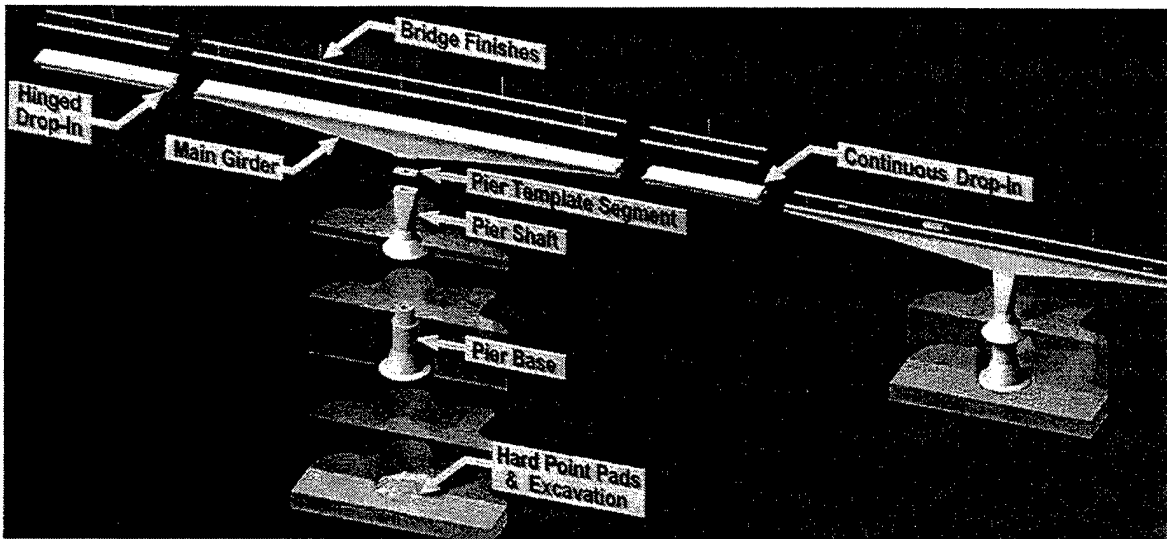


Figure 3(a) Main Bridge Components

## MAIN BRIDGE COMPONENTS

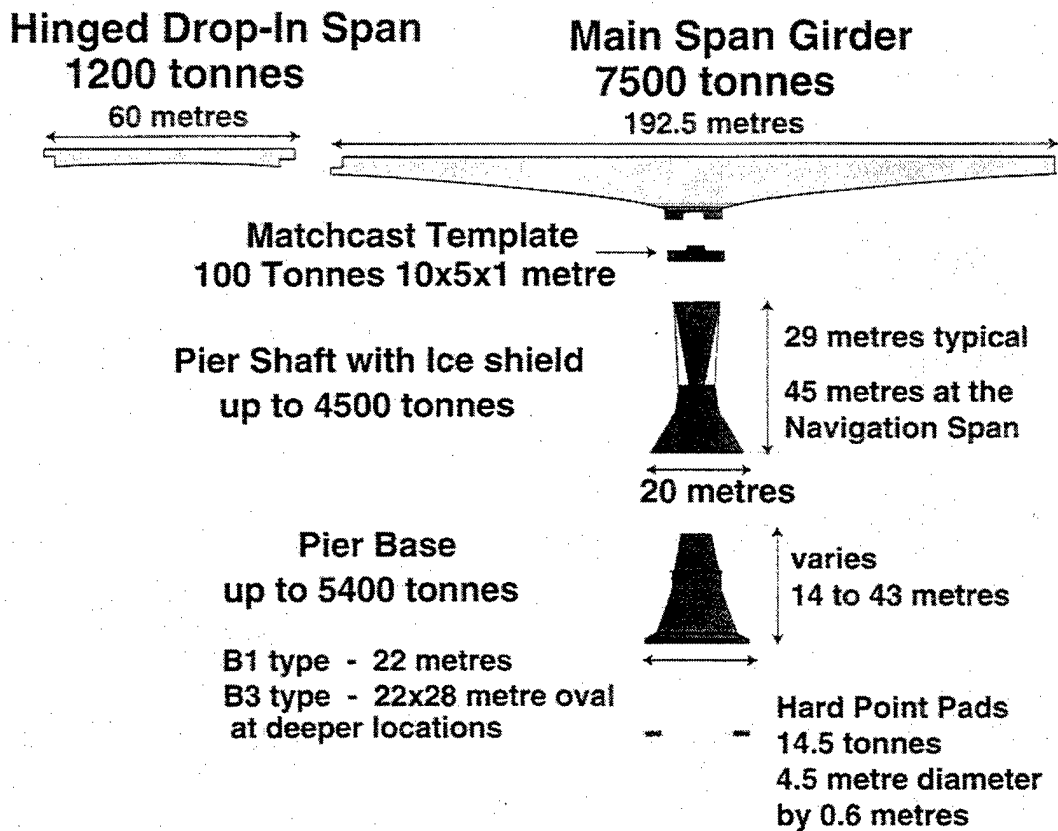


Figure 3(b) Main Bridge Components – Sizes, Shapes, and Weights

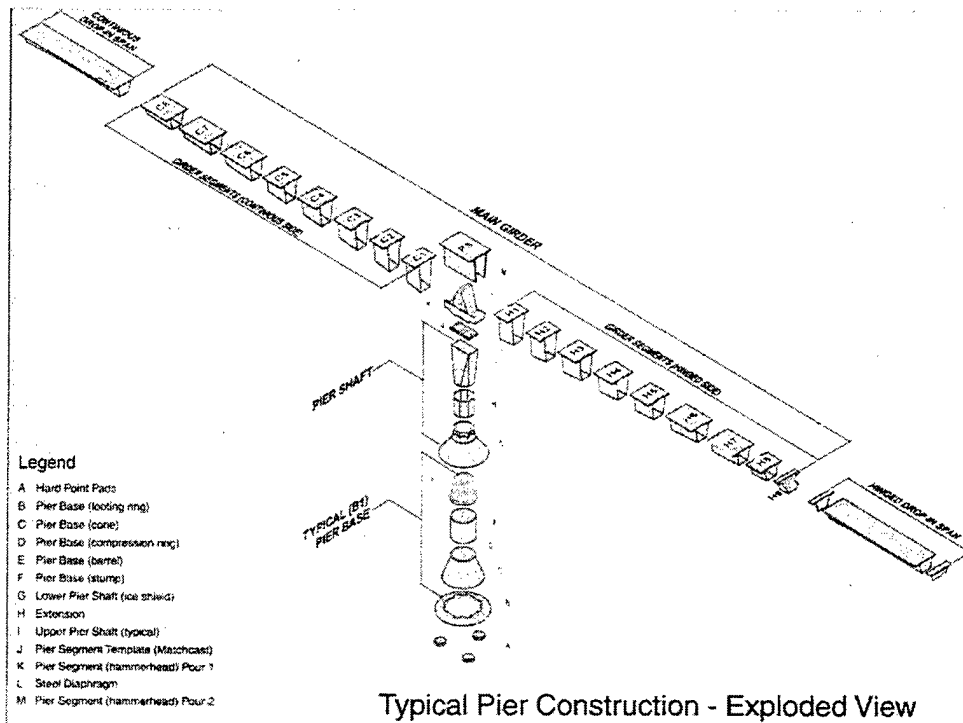


Figure 4 Isometric View of the Individually Cast Segments or Elements That Make up the Larger Components of a Main Bridge Span

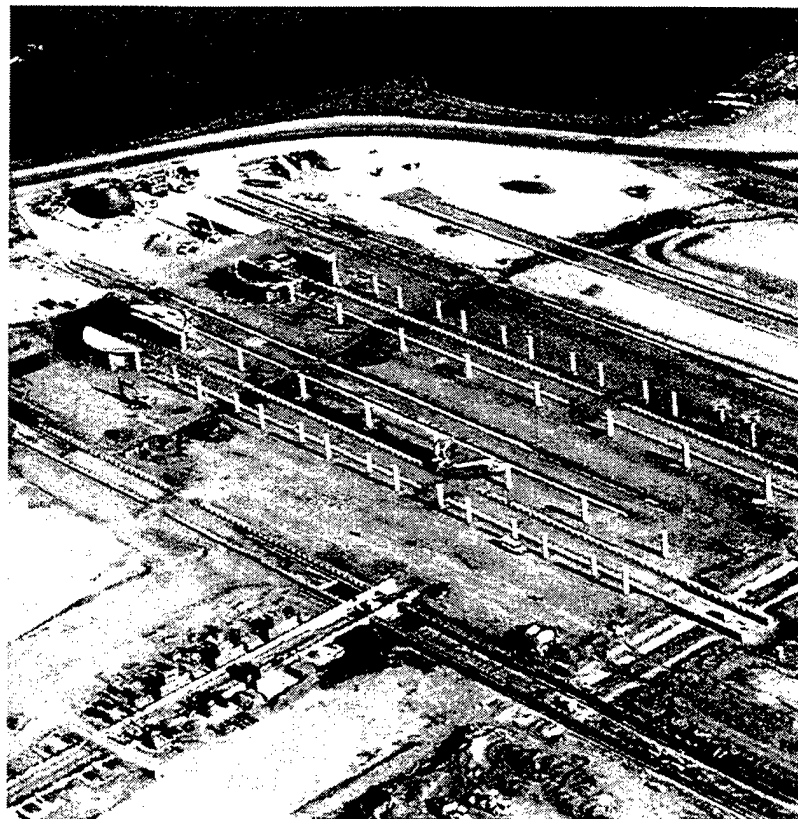


Figure 5 Initial Stage of the Precast Yard – Concrete Pillars and Skidways





Figure 6 The Precast Yard Layout and Various Stages of Production of the Pier Bases and the Main Girders

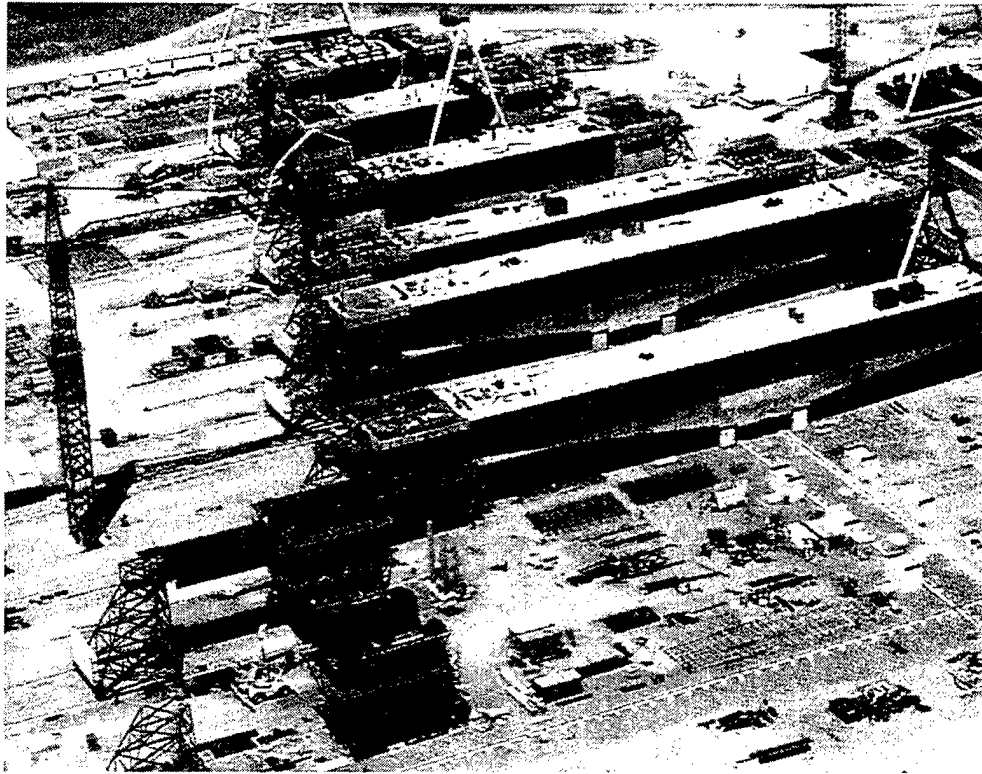


Figure 7(a) Cantilever Construction of the Main Girders on Pillars

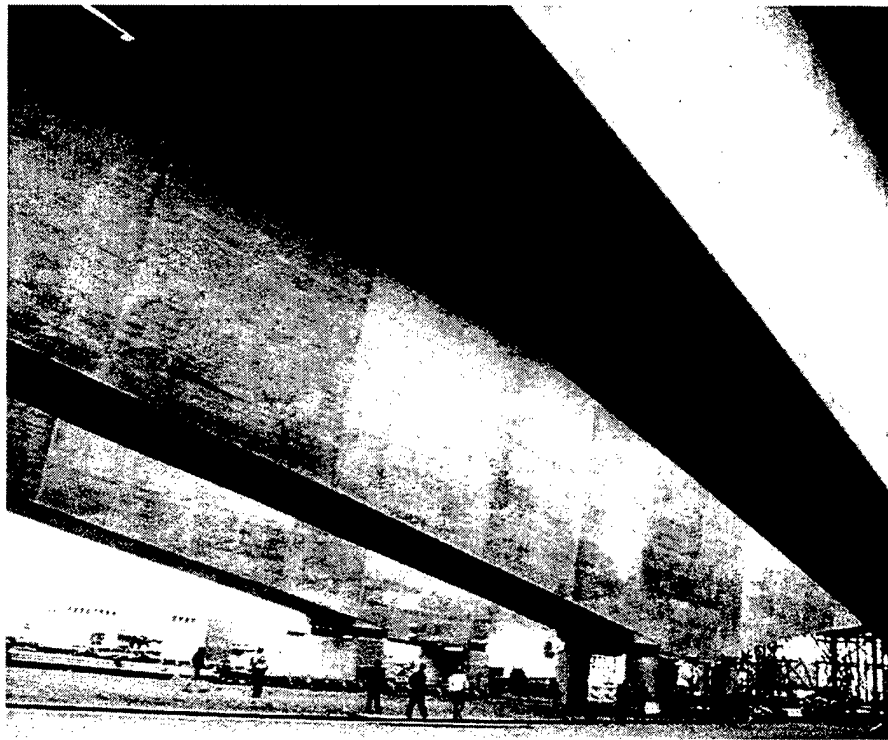


Figure 7(b) Cantilever Construction of the Main Girder on Pillars

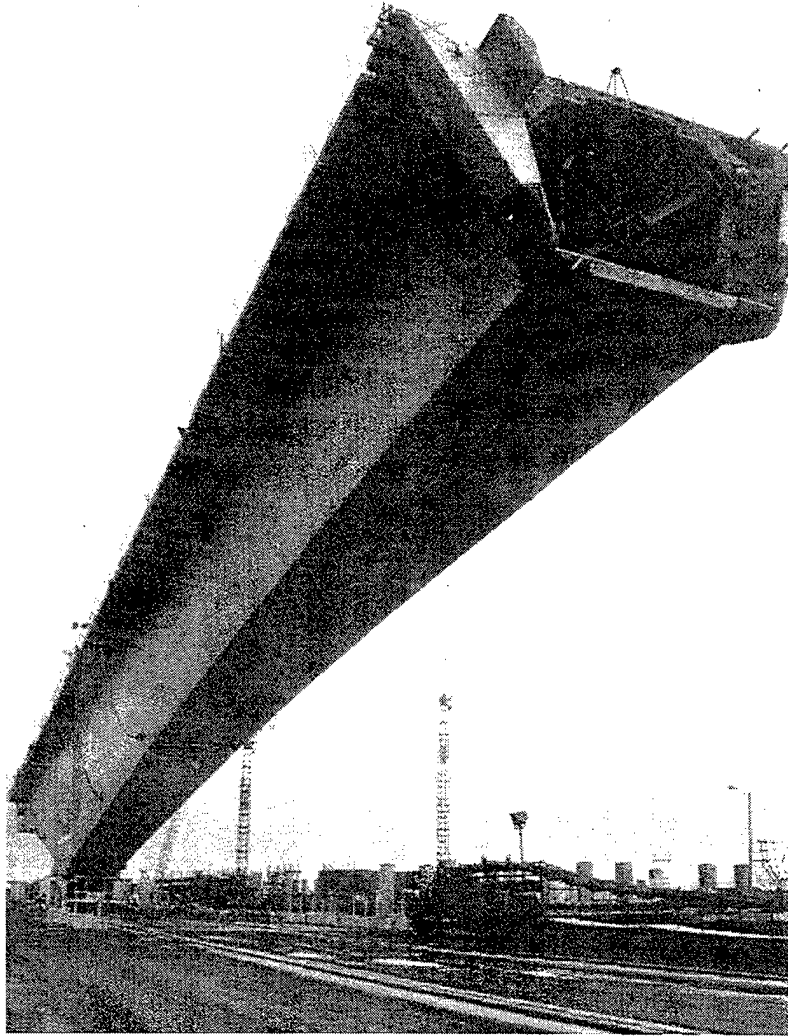


Figure 8 Moving the Main Girder on a Huisman Sledge

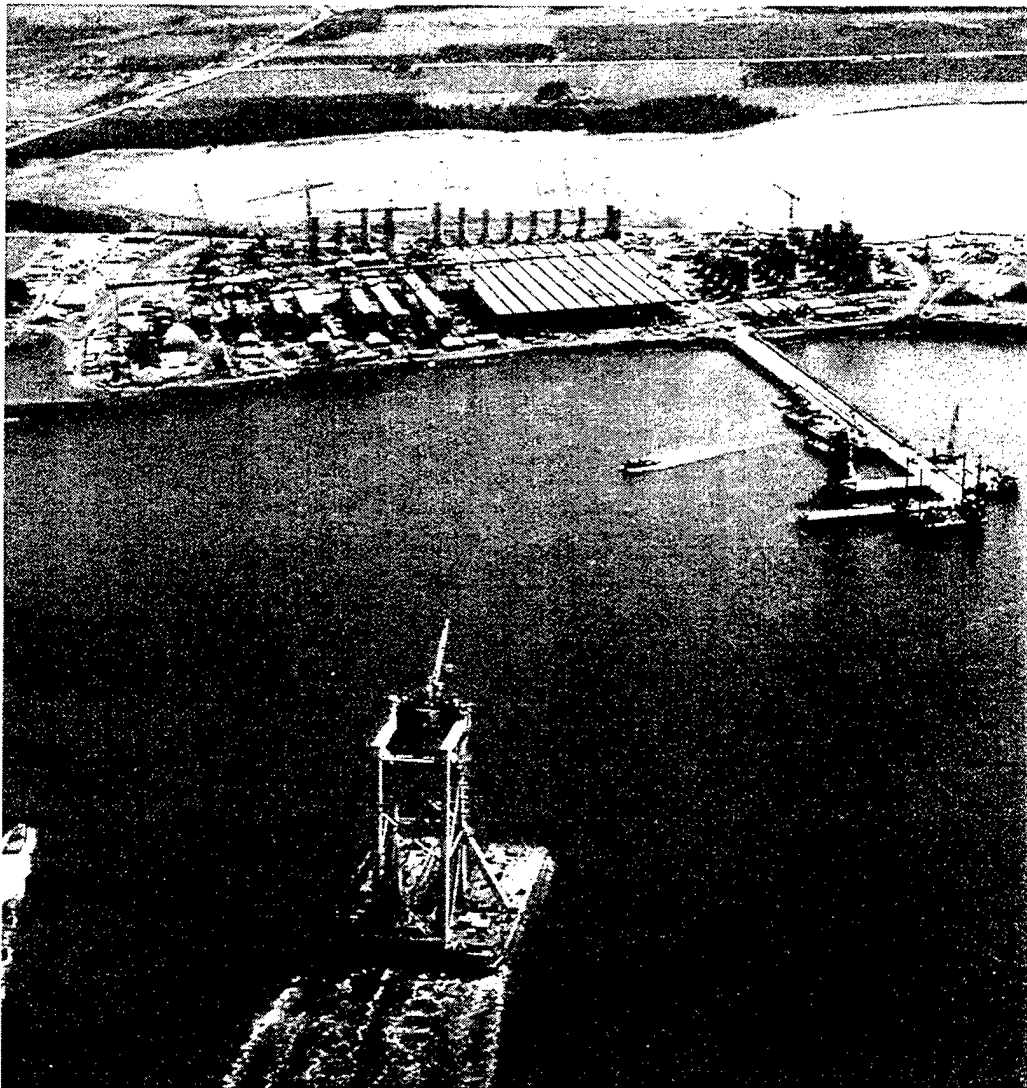


Figure 9 The Svanen approaches the 500m long jetty to pick a Pier Base

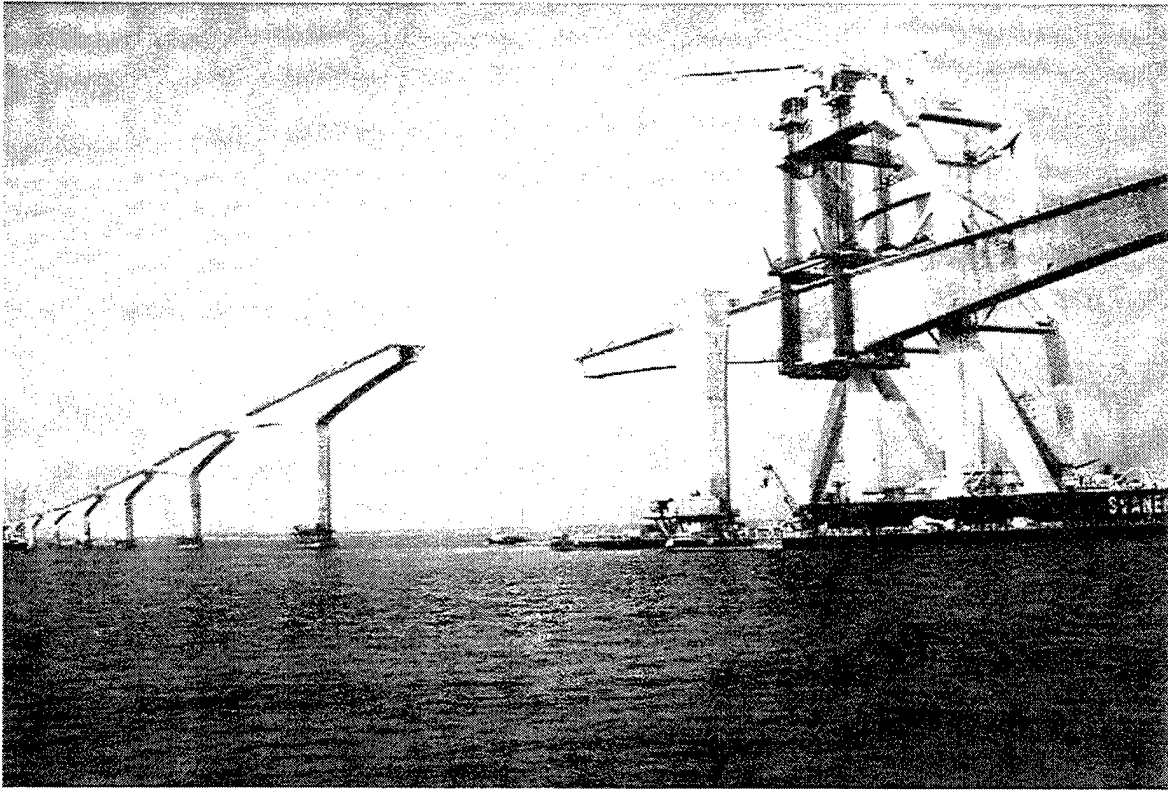


Figure 10 The Heavy Lift Vessel (Svanen) places a Main Girder in 1996

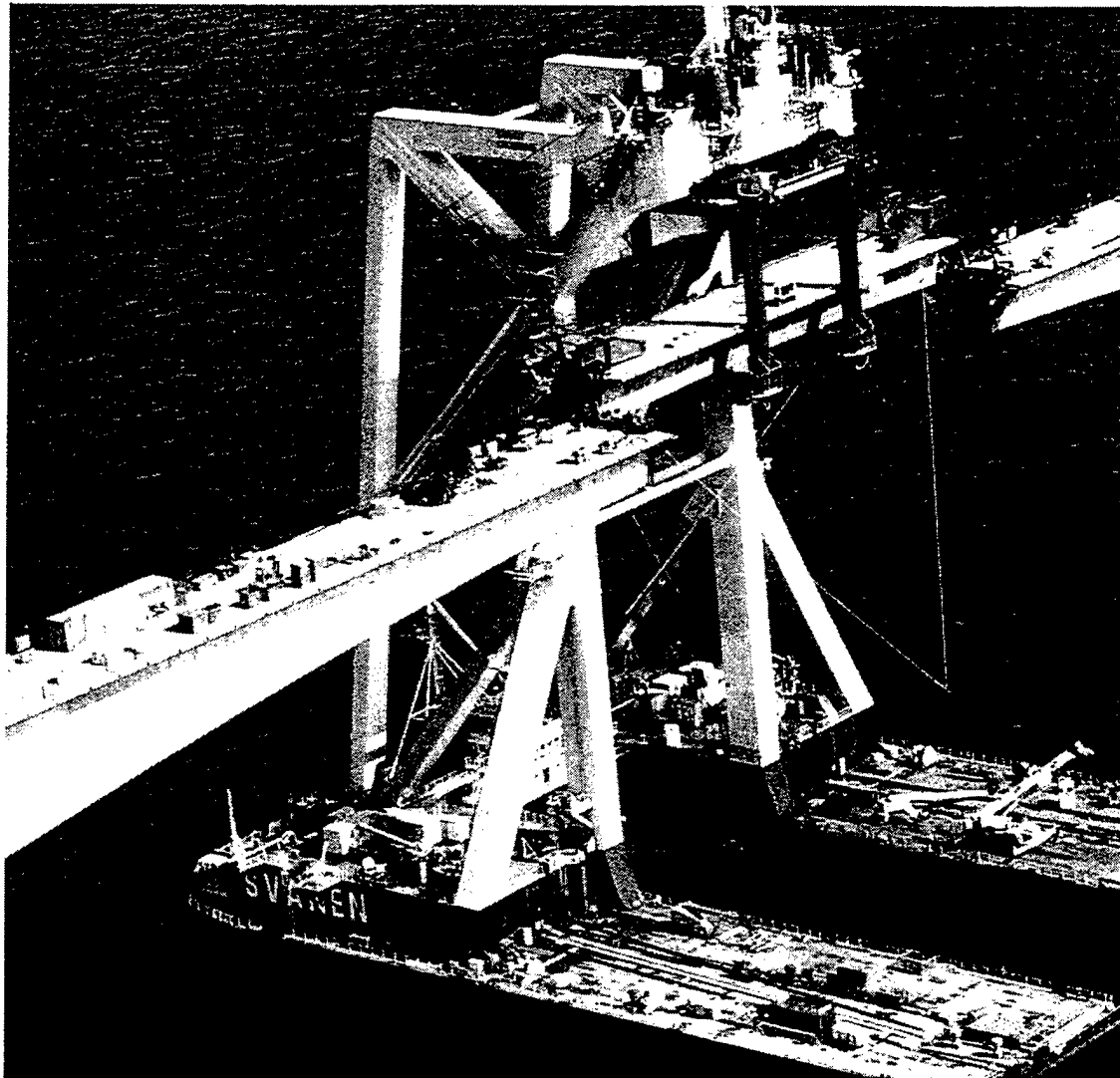


Figure 11 Placing the Last Drop-in Girder on November 19, 1996

## APPENDIX C

The attached analysis was performed as background information to analytically evaluate proposed design methodology and criteria.

The results of this work were also used to develop the preliminary designs for the Phase 1A structural confirmation test specimens.

TEST SECTION ALL UNPRESTRESSED

CASE 1

24-Sep-99

WIDTH = 12.00 DEPTH = 0.00

WIDTH = 12.00 DEPTH = 10.00

A = 120.0 I = 1000 YT= 5.00 ST= 200 SB= 200

CONCRETE STRENGTH = 8.000 KSI DENSITY = 120 PCF TRAPEZOIDAL STRESS BLOCK

MODULUS OF RUPTURE = 0.570 KSI

E = 3880.0 KSI STRAIN MULTIPLIER = 1

SPAN = 20.00 FEET

AXIAL LOAD = 0.0 KIPS, COMPRESSION POSITIVE

FIBER PROPERTIES, BASED ON NET AREA OF CARBON fu = 450 KSI E= 30000 KSI

UNPRESTRESSED FIBER DATA

AREA = 0.2032 DEPTH = 9.50

COMP STRAIN	TENSILE STRAIN	MOMENT K-FT	M/MNOM	CURVATURE RAD/IN	DEPTH OF N. AXIS	DEFL IN	LEVER ARM	FIBER STRESS
0.00000	0.00000	0.0	0.000	0.000000	0.00	0.00	0.00	0.0
0.00000	0.00000	0.0	0.000	0.000000	5.00	0.00	0.00	0.0
0.00004	0.00004	2.5	0.037	0.000008	5.00	0.05	0.00	16.6
0.00008	0.00007	5.1	0.075	0.000016	5.00	0.09	0.00	33.2
0.00012	0.00011	7.6	0.112	0.000024	5.00	0.14	0.00	49.9
0.00040	0.00222	10.2	0.150	0.000275	1.45	1.14	9.02	66.5
0.00050	0.00277	12.7	0.187	0.000344	1.45	1.84	9.02	83.1
0.00060	0.00332	15.2	0.224	0.000413	1.45	2.34	9.02	99.7
0.00070	0.00388	17.8	0.262	0.000482	1.45	2.80	9.02	116.4
0.00080	0.00443	20.3	0.299	0.000551	1.45	3.24	9.02	133.0
0.00090	0.00499	22.8	0.336	0.000620	1.45	3.67	9.02	149.6
0.00100	0.00554	25.4	0.374	0.000688	1.45	4.09	9.02	166.2
0.00110	0.00609	27.9	0.411	0.000757	1.45	4.51	9.02	182.8
0.00120	0.00665	30.5	0.449	0.000826	1.45	4.93	9.02	199.5
0.00130	0.00720	33.0	0.486	0.000895	1.45	5.35	9.02	216.1
0.00140	0.00776	35.5	0.523	0.000964	1.45	5.77	9.02	232.7
0.00150	0.00831	38.1	0.561	0.001033	1.45	6.18	9.02	249.3
0.00160	0.00887	40.6	0.598	0.001102	1.45	6.60	9.02	266.0
0.00170	0.00942	43.1	0.636	0.001170	1.45	7.01	9.02	282.6
0.00180	0.00997	45.7	0.673	0.001239	1.45	7.43	9.02	299.2
0.00190	0.01049	48.0	0.708	0.001305	1.46	7.81	9.01	314.8
0.00200	0.01099	50.3	0.741	0.001368	1.46	8.19	9.01	329.8
0.00210	0.01147	52.4	0.773	0.001429	1.47	8.54	9.00	344.1
0.00220	0.01192	54.4	0.802	0.001486	1.48	8.88	8.99	357.6
0.00230	0.01236	56.4	0.831	0.001543	1.49	9.21	8.98	370.8
0.00240	0.01277	58.2	0.857	0.001597	1.50	9.52	8.97	383.1
0.00250	0.01318	60.0	0.884	0.001651	1.51	9.84	8.96	395.4
0.00260	0.01356	61.6	0.908	0.001701	1.53	10.13	8.95	406.8
0.00270	0.01394	63.3	0.933	0.001751	1.54	10.42	8.94	418.1
0.00280	0.01430	64.8	0.955	0.001800	1.56	10.69	8.93	428.9
0.00290	0.01466	66.4	0.978	0.001848	1.57	10.97	8.92	439.7
0.00300	0.01502	67.9	1.000	0.001897	1.58	11.24	8.91	450.0

SERVICE LOAD LEVEL RESULTS

0.00043 0.00240 11.0 0.162 0.000298 1.45 1.43 0.00 72.0

ZERO T = 0.0 K-FT

CRACKING = 9.5 K-FT

SERVICE = 11.0 K-FT

HI = 0.900 MU = 61.1 K-FT MU/(B\*H^2) = 0.611 K/IN^2



TEST SECTION ALL PRESTRESSED

CASE 2

24-Sep-99

WIDTH = 12.00 DEPTH = 0.00  
 WIDTH = 12.00 DEPTH = 10.00  
 A = 120.0 I = 1000 YT= 5.00 ST= 200 SB= 200  
 CONCRETE STRENGTH = 8.000 KSI DENSITY = 120 PCF TRAPEZOIDAL STRESS BLOCK  
 MODULUS OF RUPTURE = 0.570 KSI  
 E = 3880.0 KSI STRAIN MULTIPLIER = 1  
 SPAN = 20.00 FEET  
 AXIAL LOAD = 0.0 KIPS, COMPRESSION POSITIVE  
 FIBER PROPERTIES, BASED ON NET AREA OF CARBON fu = 450 KSI E= 30000 KSI  
 UNSTRESSED FIBER DATA  
 AREA = 0.0000 DEPTH = 9.50  
 PRESTRESSING DATA EFFECTIVE PRESTRESS fse = 170.00 KSI  
 AREA = 0.2032 DEPTH = 6.50

COMP STRAIN	TENSILE STRAIN	MOMENT K-FT	M/MNOM	CURVATURE RAD/IN	DEPTH OF N. AXIS	DEFL IN	LEVER ARM	FIBER STRESS
-0.00001	-0.00013	0.0	0.000	-0.000013	-0.56	-0.10	0.00	-4.0
0.00000	-0.00014	-0.5	-0.010	-0.000015	0.00	-0.10	-0.17	-4.2
-0.00010	-0.00005	6.0	0.133	0.000005	19.34	0.02	2.08	-1.5
-0.00019	0.00003	11.6	0.257	0.000022	8.31	0.12	4.02	1.7
-0.00023	0.00006	14.1	0.313	0.000030	7.45	0.17	4.90	8.0
-0.00025	0.00008	15.7	0.349	0.000035	7.11	0.20	5.45	17.3
-0.00027	0.00010	17.0	0.378	0.000039	6.89	0.22	5.91	29.1
-0.00029	0.00012	18.2	0.405	0.000043	6.72	0.24	6.33	42.7
-0.00070	0.00193	19.4	0.432	0.000277	2.53	0.76	5.66	57.8
-0.00080	0.00247	20.7	0.459	0.000344	2.33	1.26	5.72	74.1
-0.00090	0.00304	21.9	0.486	0.000415	2.17	1.68	5.78	91.1
-0.00100	0.00363	23.1	0.514	0.000487	2.05	2.10	5.82	108.9
-0.00110	0.00424	24.4	0.542	0.000562	1.96	2.53	5.85	127.1
-0.00120	0.00486	25.7	0.571	0.000638	1.88	2.96	5.87	145.9
-0.00130	0.00550	27.0	0.600	0.000716	1.82	3.41	5.89	164.9
-0.00140	0.00614	28.3	0.629	0.000794	1.76	3.86	5.91	184.2
0.00150	0.00679	29.6	0.658	0.000873	1.72	4.31	5.93	203.8
0.00160	0.00745	31.0	0.688	0.000953	1.68	4.78	5.94	223.5
0.00170	0.00811	32.3	0.717	0.001033	1.65	5.24	5.95	243.3
0.00180	0.00878	33.6	0.747	0.001114	1.62	5.72	5.96	263.5
0.00190	0.00941	34.9	0.775	0.001191	1.60	6.16	5.96	282.4
0.00200	0.01002	36.0	0.800	0.001265	1.58	6.58	5.97	300.5
0.00210	0.01060	37.1	0.825	0.001337	1.57	6.99	5.96	318.0
0.00220	0.01115	38.2	0.848	0.001405	1.57	7.37	5.96	334.6
0.00230	0.01169	39.1	0.870	0.001473	1.56	7.74	5.96	350.7
0.00240	0.01221	40.1	0.890	0.001537	1.56	8.11	5.95	366.2
0.00250	0.01271	41.0	0.911	0.001601	1.56	8.46	5.94	381.3
0.00260	0.01319	41.8	0.930	0.001662	1.56	8.80	5.94	395.8
0.00270	0.01368	42.7	0.948	0.001724	1.57	9.14	5.93	410.3
0.00280	0.01413	43.5	0.966	0.001782	1.57	9.46	5.92	423.8
0.00290	0.01458	44.2	0.983	0.001840	1.58	9.78	5.92	437.3
0.00300	0.01502	45.0	1.000	0.001897	1.58	10.10	5.91	450.0
SERVICE LOAD LEVEL RESULTS								
0.00079	0.00240	20.5	0.456	0.000336	2.35	1.20	0.00	72.0
ZERO T	=	9.1	K-FT					
CRACKING	=	18.6	K-FT					
SERVICE	=	20.5	K-FT					
HI	=	0.900	MU = 40.5 K-FT	MU/(B*H^2) = 0.405	K/IN^2			

TEST SECTION PRESTRESSED AND UNPRESTRESSED  
24-Sep-99

CASE 3

WIDTH = 12.00 DEPTH = 0.00  
 WIDTH = 12.00 DEPTH = 10.00  
 A = 120.0 I = 1000 YT= 5.00 ST= 200 SB= 200  
 CONCRETE STRENGTH = 8.000 KSI DENSITY = 120 PCF TRAPEZOIDAL STRESS BLOCK  
 MODULUS OF RUPTURE = 0.570 KSI  
 E = 3880.0 KSI STRAIN MULTIPLIER = 1  
 SPAN = 20.00 FEET  
 AXIAL LOAD = 0.0 KIPS, COMPRESSION POSITIVE  
 FIBER PROPERTIES, BASED ON NET AREA OF CARBON fu = 450 KSI E= 30000 KSI  
 UNSTRESSED FIBER DATA  
 AREA = 0.0960 DEPTH = 9.50  
 PRESTRESSING DATA EFFECTIVE PRESTRESS fse = 170.00 KSI  
 AREA = 0.1072 DEPTH = 6.50

COMP STRAIN	TENSILE STRAIN	MOMENT K-FT	M/MNOM	CURVATURE RAD/IN	DEPTH OF N. AXIS	DEFL IN	LEVER ARM	FIBER STRESS
0.00000	-0.00007	0.0	0.000	-0.000007	-0.56	-0.05	0.00	-2.1
0.00000	-0.00007	-0.3	-0.005	-0.000008	0.00	-0.05	-0.20	-2.2
-0.00010	0.00001	5.9	0.106	0.000011	8.47	0.06	3.90	0.6
-0.00013	0.00005	8.4	0.151	0.000019	7.06	0.11	5.55	7.7
-0.00016	0.00007	10.1	0.182	0.000024	6.61	0.14	6.68	19.2
-0.00019	0.00009	11.9	0.212	0.000030	6.32	0.17	7.81	33.3
-0.00021	0.00012	13.6	0.244	0.000035	6.11	0.20	8.98	48.8
-0.00060	0.00218	15.5	0.277	0.000292	2.05	0.96	6.47	65.3
-0.00070	0.00274	17.3	0.310	0.000363	1.93	1.60	6.61	82.3
-0.00080	0.00332	19.2	0.344	0.000434	1.84	2.11	6.72	99.7
-0.00090	0.00391	21.1	0.379	0.000507	1.78	2.59	6.82	117.4
-0.00100	0.00451	23.1	0.413	0.000580	1.72	3.05	6.90	135.3
-0.00110	0.00511	25.0	0.448	0.000654	1.68	3.51	6.96	153.3
-0.00120	0.00571	26.9	0.483	0.000728	1.65	3.96	7.02	171.4
-0.00130	0.00632	28.9	0.518	0.000802	1.62	4.42	7.07	189.7
-0.00140	0.00693	30.9	0.553	0.000877	1.60	4.87	7.12	208.0
-0.00150	0.00754	32.8	0.588	0.000952	1.58	5.33	7.16	226.3
-0.00160	0.00815	34.8	0.623	0.001027	1.56	5.78	7.19	244.6
-0.00170	0.00876	36.7	0.658	0.001102	1.54	6.23	7.23	262.9
-0.00180	0.00938	38.7	0.694	0.001177	1.53	6.69	7.25	281.5
-0.00190	0.00996	40.6	0.727	0.001249	1.52	7.11	7.28	298.8
-0.00200	0.01051	42.3	0.758	0.001317	1.52	7.51	7.29	315.4
-0.00210	0.01105	44.0	0.788	0.001384	1.52	7.91	7.30	331.4
-0.00220	0.01155	45.5	0.815	0.001447	1.52	8.27	7.31	346.4
-0.00230	0.01203	47.0	0.842	0.001509	1.52	8.63	7.32	361.0
-0.00240	0.01250	48.4	0.867	0.001568	1.53	8.97	7.32	374.9
-0.00250	0.01295	49.7	0.891	0.001626	1.54	9.31	7.33	388.5
-0.00260	0.01338	51.0	0.914	0.001682	1.55	9.62	7.33	401.3
-0.00270	0.01381	52.3	0.937	0.001738	1.55	9.95	7.33	414.2
-0.00280	0.01421	53.5	0.958	0.001791	1.56	10.25	7.33	426.4
-0.00290	0.01462	54.7	0.980	0.001844	1.57	10.55	7.33	438.5
-0.00300	0.01502	55.8	1.000	0.001897	1.58	10.85	7.33	450.0
SERVICE LOAD LEVEL RESULTS								
-0.00064	0.00240	16.2	0.290	0.000320	2.00	1.25	0.00	72.0
1 ZERO T	=	4.8 K-FT						
1 CRACKING	=	14.3 K-FT						
1 SERVICE	=	16.2 K-FT						
PHI	=	0.900	MU = 50.2 K-FT	MU/(B*H^2) = 0.502 K/IN^2				

TEST SECTION PRESTRESSED AND UNPRESTRESSED  
24-Sep-99

CASE 4A

WIDTH = 12.00 DEPTH = 0.00  
 WIDTH = 12.00 DEPTH = 13.40  
 A = 160.8 I = 2406 YT= 6.70 ST= 359 SB= 359  
 CONCRETE STRENGTH = 8.000 KSI DENSITY = 120 PCF TRAPEZOIDAL STRESS BLOCK  
 MODULUS OF RUPTURE = 0.570 KSI  
 E = 3880.0 KSI STRAIN MULTIPLIER = 1  
 SPAN = 20.00 FEET  
 AXIAL LOAD = 0.0 KIPS, COMPRESSION POSITIVE  
 FIBER PROPERTIES, BASED ON NET AREA OF CARBON  $f_u = 450$  KSI  $E = 30000$  KSI  
 UNSTRESSED FIBER DATA  
 AREA = 0.1287 DEPTH = 12.73  
 PRESTRESSING DATA EFFECTIVE PRESTRESS  $f_{se} = 180.00$  KSI  
 AREA = 0.1437 DEPTH = 8.71

COMP STRAIN	TENSILE STRAIN	MOMENT K-FT	M/MNOM	CURVATURE RAD/IN	DEPTH OF N. AXIS	DEFL IN	LEVER ARM	FIBER STRESS
0.000000	-0.000008	0.0	0.000	-0.000006	-0.74	-0.04	0.00	-2.3
0.000000	-0.000008	-0.6	-0.006	-0.000006	0.00	-0.04	-0.27	-2.3
-0.000010	0.000001	10.8	0.110	0.000008	11.68	0.04	5.01	0.4
-0.000014	0.000005	15.6	0.159	0.000015	9.55	0.08	7.25	7.1
-0.000017	0.000007	18.8	0.190	0.000019	8.94	0.10	8.70	18.1
-0.000019	0.000009	21.8	0.222	0.000022	8.54	0.13	10.12	31.7
-0.000022	0.000012	25.0	0.254	0.000027	8.26	0.15	11.59	47.0
-0.000060	0.00211	28.2	0.287	0.000213	2.82	0.70	8.60	63.2
-0.000070	0.00267	31.6	0.320	0.000265	2.64	1.16	8.79	80.1
-0.000080	0.00325	34.9	0.355	0.000318	2.52	1.53	8.94	97.4
-0.000090	0.00383	38.4	0.390	0.000372	2.42	1.88	9.07	114.9
-0.00100	0.00442	41.8	0.424	0.000426	2.35	2.23	9.18	132.7
-0.00110	0.00502	45.3	0.460	0.000481	2.29	2.57	9.28	150.7
-0.00120	0.00562	48.8	0.495	0.000536	2.24	2.90	9.36	168.7
-0.00130	0.00623	52.3	0.531	0.000591	2.20	3.24	9.43	186.8
-0.00140	0.00684	55.8	0.566	0.000647	2.16	3.58	9.49	205.1
-0.00150	0.00745	59.3	0.602	0.000703	2.13	3.92	9.55	223.4
-0.00160	0.00806	62.8	0.638	0.000758	2.11	4.25	9.60	241.7
-0.00170	0.00867	66.3	0.674	0.000814	2.09	4.59	9.64	260.0
-0.00180	0.00928	69.9	0.710	0.000870	2.07	4.93	9.68	278.3
-0.00190	0.00986	73.2	0.743	0.000924	2.06	5.24	9.71	295.7
-0.00200	0.01041	76.3	0.775	0.000975	2.05	5.54	9.73	312.3
-0.00210	0.01094	79.3	0.805	0.001024	2.05	5.84	9.75	328.2
-0.00220	0.01144	82.0	0.833	0.001071	2.05	6.11	9.76	343.2
-0.00230	0.01193	84.7	0.860	0.001117	2.06	6.37	9.77	357.8
-0.00240	0.01239	87.2	0.885	0.001162	2.07	6.63	9.78	371.6
-0.00250	0.01284	89.6	0.910	0.001205	2.07	6.88	9.78	385.2
-0.00260	0.01327	91.9	0.933	0.001247	2.09	7.12	9.79	398.2
-0.00270	0.01371	94.2	0.957	0.001289	2.10	7.36	9.79	411.2
-0.00280	0.01411	96.4	0.979	0.001328	2.11	7.58	9.79	423.3
-0.00290	0.01452	98.5	1.000	0.001368	2.12	7.81	9.79	435.5

RUPTURE OF STRESSED FIBER

SERVICE LOAD LEVEL RESULTS  
 -0.00065 0.00240 30.0 0.304 0.000240 2.72 0.97 0.00 72.0  
 M ZERO T = 9.1 K-FT  
 M CRACKING = 26.2 K-FT  
 M SERVICE = 30.0 K-FT  
 PHI = 0.900 MU = 88.6 K-FT  $MU/(B \cdot H^2) = 0.494$  K/IN<sup>2</sup>

TEST SECTION PRESTRESSED AND UNPRESTRESSED  
 24-Sep-99

CASE 4B

WIDTH = 12.00 DEPTH = 0.00  
 WIDTH = 12.00 DEPTH = 12.00  
 A = 144.0 I = 1728 YT= 6.00 ST= 288 SB= 288  
 CONCRETE STRENGTH = 8.000 KSI DENSITY = 120 PCF TRAPEZOIDAL STRESS BLOCK  
 MODULUS OF RUPTURE = 0.570 KSI  
 E = 3880.0 KSI STRAIN MULTIPLIER = 1  
 SPAN = 20.00 FEET  
 AXIAL LOAD = 0.0 KIPS, COMPRESSION POSITIVE  
 FIBER PROPERTIES, BASED ON NET AREA OF CARBON  $f_u = 450$  KSI  $E = 30000$  KSI  
 UNSTRESSED FIBER DATA  
 AREA = 0.1200 DEPTH = 11.40  
 PRESTRESSING DATA EFFECTIVE PRESTRESS  $f_{se} = 180.00$  KSI  
 AREA = 0.1760 DEPTH = 7.80

COMP STRAIN	TENSILE STRAIN	MOMENT K-FT	M/MNOM	CURVATURE RAD/IN	DEPTH OF N. AXIS	DEFL IN	LEVER ARM	FIBER STRESS
-0.00001	-0.00010	0.0	0.000	-0.000009	-0.67	-0.06	0.00	-3.1
0.00000	-0.00011	-0.6	-0.007	-0.000009	0.00	-0.07	-0.24	-3.2
-0.00010	-0.00002	8.8	0.103	0.000007	13.89	0.03	3.32	-0.5
-0.00017	0.00004	14.9	0.174	0.000018	9.12	0.10	5.64	3.9
-0.00020	0.00007	18.0	0.210	0.000024	8.40	0.13	6.80	12.0
-0.00023	0.00010	20.6	0.241	0.000028	8.00	0.16	7.80	22.9
-0.00025	0.00012	23.2	0.271	0.000033	7.72	0.19	8.78	35.5
-0.00060	0.00165	25.8	0.302	0.000197	3.05	0.65	7.29	49.4
-0.00070	0.00213	28.5	0.334	0.000248	2.82	1.06	7.46	64.0
-0.00080	0.00264	31.3	0.366	0.000302	2.65	1.41	7.61	79.2
-0.00090	0.00316	34.1	0.399	0.000356	2.53	1.75	7.73	94.8
-0.00100	0.00369	37.0	0.432	0.000411	2.43	2.09	7.83	110.6
-0.00110	0.00422	39.8	0.466	0.000467	2.36	2.43	7.92	126.7
-0.00120	0.00477	42.7	0.500	0.000523	2.29	2.77	8.00	143.0
-0.00130	0.00531	45.6	0.533	0.000580	2.24	3.11	8.07	159.3
-0.00140	0.00586	48.5	0.567	0.000637	2.20	3.45	8.13	175.8
-0.00150	0.00641	51.4	0.602	0.000694	2.16	3.79	8.18	192.4
-0.00160	0.00697	54.4	0.636	0.000752	2.13	4.14	8.23	209.1
-0.00170	0.00752	57.3	0.670	0.000809	2.10	4.48	8.27	225.7
-0.00180	0.00808	60.2	0.705	0.000867	2.08	4.83	8.31	242.5
-0.00190	0.00861	63.0	0.737	0.000922	2.06	5.15	8.34	258.3
-0.00200	0.00911	65.5	0.767	0.000975	2.05	5.46	8.36	273.4
-0.00210	0.00959	68.0	0.795	0.001026	2.05	5.76	8.38	287.8
-0.00220	0.01006	70.3	0.822	0.001075	2.05	6.04	8.39	301.7
-0.00230	0.01049	72.5	0.848	0.001122	2.05	6.31	8.40	314.8
-0.00240	0.01092	74.6	0.872	0.001169	2.05	6.58	8.41	327.6
-0.00250	0.01133	76.5	0.895	0.001213	2.06	6.83	8.41	339.9
-0.00260	0.01173	78.5	0.918	0.001257	2.07	7.08	8.41	351.9
-0.00270	0.01211	80.3	0.939	0.001299	2.08	7.32	8.41	363.3
-0.00280	0.01249	82.1	0.961	0.001341	2.09	7.56	8.42	374.7
-0.00290	0.01284	83.8	0.980	0.001381	2.10	7.78	8.42	385.3
-0.00300	0.01320	85.5	1.000	0.001421	2.11	8.01	8.41	396.1
SERVICE LOAD LEVEL RESULTS								
-0.00075	0.00240	30.0	0.351	0.000277	2.72	1.25	0.00	72.0
I ZERO T = 10.0 K-FT								
I CRACKING = 23.7 K-FT								
I SERVICE = 30.0 K-FT								
I HI = 0.900 MU = 76.9 K-FT $MU/(B*H^2) = 0.534$ K/IN^2								

TEST SECTION PRESTRESSED AND UNPRESTRESSED  
24-Sep-99

CASE 5

WIDTH = 12.00 DEPTH = 0.00  
 WIDTH = 12.00 DEPTH = 10.00  
 A = 120.0 I = 1000 YT= 5.00 ST= 200 SB= 200  
 CONCRETE STRENGTH = 8.000 KSI DENSITY = 120 PCF TRAPEZOIDAL STRESS BLOCK  
 MODULUS OF RUPTURE = 0.570 KSI  
 E = 3880.0 KSI STRAIN MULTIPLIER = 1  
 SPAN = 20.00 FEET  
 AXIAL LOAD = 0.0 KIPS, COMPRESSION POSITIVE  
 FIBER PROPERTIES, BASED ON NET AREA OF CARBON fu = 450 KSI E= 30000 KSI  
 UNSTRESSED FIBER DATA  
 AREA = 0.0960 DEPTH = 9.50  
 PRESTRESSING DATA EFFECTIVE PRESTRESS fse = 180.00 KSI  
 AREA = 0.2440 DEPTH = 6.50

COMP STRAIN	TENSILE STRAIN	MOMENT K-FT	M/MNOM	CURVATURE RAD/IN	DEPTH OF N. AXIS	DEFL IN	LEVER ARM	FIBER STRESS
-0.00001	-0.00017	0.0	0.000	-0.000017	-0.56	-0.12	0.00	-5.1
0.00000	-0.00017	-0.7	-0.011	-0.000018	0.00	-0.13	-0.20	-5.2
-0.00010	-0.00009	5.8	0.089	0.000001	100.66	-0.01	1.59	-2.6
-0.00020	0.00000	12.3	0.188	0.000021	9.50	0.11	3.35	0.1
-0.00026	0.00006	16.3	0.250	0.000033	7.82	0.18	4.46	4.4
-0.00030	0.00009	18.8	0.289	0.000041	7.28	0.23	5.15	11.1
-0.00033	0.00012	20.9	0.321	0.000048	6.97	0.27	5.72	19.6
-0.00060	0.00098	22.9	0.351	0.000167	3.60	0.59	5.47	29.5
-0.00070	0.00135	24.9	0.381	0.000215	3.25	0.90	5.64	40.4
-0.00080	0.00174	26.8	0.411	0.000267	2.99	1.19	5.77	52.1
-0.00090	0.00215	28.8	0.442	0.000321	2.81	1.50	5.88	64.4
-0.00100	0.00257	30.8	0.472	0.000376	2.66	1.81	5.97	77.2
-0.00110	0.00301	32.8	0.503	0.000432	2.54	2.13	6.05	90.3
-0.00120	0.00345	34.9	0.535	0.000490	2.45	2.46	6.12	103.6
-0.00130	0.00391	36.9	0.567	0.000548	2.37	2.79	6.18	117.3
-0.00140	0.00437	39.0	0.598	0.000607	2.31	3.13	6.23	131.1
-0.00150	0.00483	41.1	0.630	0.000666	2.25	3.48	6.28	144.9
-0.00160	0.00530	43.2	0.663	0.000726	2.20	3.83	6.32	159.0
-0.00170	0.00577	45.3	0.695	0.000786	2.16	4.18	6.36	173.1
-0.00180	0.00625	47.5	0.728	0.000847	2.13	4.54	6.40	187.4
-0.00190	0.00670	49.4	0.758	0.000905	2.10	4.87	6.42	200.9
-0.00200	0.00712	51.3	0.786	0.000960	2.08	5.19	6.44	213.7
-0.00210	0.00753	53.0	0.812	0.001014	2.07	5.49	6.45	226.0
-0.00220	0.00792	54.6	0.837	0.001066	2.06	5.78	6.46	237.7
-0.00230	0.00830	56.1	0.860	0.001116	2.06	6.06	6.47	249.0
-0.00240	0.00867	57.6	0.883	0.001165	2.06	6.33	6.48	260.0
-0.00250	0.00902	59.0	0.904	0.001212	2.06	6.60	6.48	270.5
-0.00260	0.00936	60.3	0.925	0.001259	2.07	6.85	6.48	280.7
-0.00270	0.00969	61.6	0.945	0.001304	2.07	7.10	6.48	290.7
-0.00280	0.01001	62.9	0.964	0.001348	2.08	7.35	6.48	300.3
-0.00290	0.01032	64.1	0.982	0.001392	2.08	7.59	6.48	309.7
-0.00300	0.01063	65.2	1.000	0.001435	2.09	7.82	6.48	318.9
SERVICE LOAD LEVEL RESULTS								
-0.00096	0.00240	30.0	0.460	0.000354	2.71	1.68	0.00	72.0
1 ZERO T	=	11.6 K-FT						
1 CRACKING	=	21.1 K-FT						
1 SERVICE	=	30.0 K-FT						
PHI = 0.900	MU =	58.7 K-FT		MU/(B*H^2) = 0.587 K/IN^2				

TEST SECTION PRESTRESSED AND UNPRESTRESSED  
 24-Sep-99

CASE 6

WIDTH = 12.00 DEPTH = 0.00  
 WIDTH = 12.00 DEPTH = 10.00  
 A = 120.0 I = 1000 YT= 5.00 ST= 200 SB= 200  
 CONCRETE STRENGTH = 8.000 KSI DENSITY = 120 PCF TRAPEZOIDAL STRESS BLOCK  
 MODULUS OF RUPTURE = 0.570 KSI  
 E = 3880.0 KSI STRAIN MULTIPLIER = 1  
 SPAN = 20.00 FEET  
 AXIAL LOAD = 0.0 KIPS, COMPRESSION POSITIVE  
 FIBER PROPERTIES, BASED ON NET AREA OF CARBON fu = 450 KSI E= 30000 KSI  
 UNSTRESSED FIBER DATA  
 AREA = 0.0960 DEPTH = 9.50  
 PRESTRESSING DATA EFFECTIVE PRESTRESS fse = 180.00 KSI  
 AREA = 0.4130 DEPTH = 6.50

COMP STRAIN	TENSILE STRAIN	MOMENT K-FT	M/MNOM	CURVATURE RAD/IN	DEPTH OF N. AXIS	DEFL IN	LEVER ARM	FIBER STRESS
-0.00002	-0.00029	0.0	0.000	-0.000029	-0.56	-0.21	0.00	-8.7
0.00000	-0.00029	-1.2	-0.016	-0.000031	0.00	-0.22	-0.20	-8.7
-0.00010	-0.00021	5.3	0.071	-0.000012	-8.01	-0.11	0.86	-6.1
-0.00020	-0.00012	11.8	0.157	0.000008	25.21	0.01	1.91	-3.4
-0.00030	-0.00003	18.4	0.244	0.000028	10.69	0.13	2.97	-0.8
-0.00038	0.00004	23.8	0.315	0.000045	8.57	0.23	3.84	2.4
-0.00044	0.00009	27.4	0.363	0.000056	7.85	0.30	4.42	7.1
-0.00060	0.00043	30.2	0.401	0.000109	5.51	0.47	4.71	13.0
-0.00070	0.00067	32.7	0.433	0.000144	4.86	0.65	4.95	20.0
-0.00080	0.00093	35.0	0.464	0.000182	4.39	0.83	5.13	27.9
-0.00090	0.00122	37.2	0.494	0.000223	4.04	1.02	5.28	36.5
-0.00100	0.00152	39.4	0.523	0.000265	3.77	1.24	5.39	45.6
-0.00110	0.00184	41.6	0.552	0.000310	3.55	1.46	5.49	55.3
-0.00120	0.00218	43.8	0.581	0.000355	3.38	1.70	5.57	65.3
-0.00130	0.00252	46.0	0.610	0.000402	3.23	1.95	5.64	75.6
-0.00140	0.00287	48.3	0.640	0.000450	3.11	2.21	5.71	86.1
-0.00150	0.00323	50.5	0.670	0.000498	3.01	2.47	5.76	96.9
-0.00160	0.00360	52.7	0.699	0.000547	2.92	2.74	5.81	107.9
-0.00170	0.00397	55.0	0.729	0.000597	2.85	3.02	5.85	119.0
-0.00180	0.00434	57.3	0.759	0.000646	2.78	3.30	5.89	130.2
-0.00190	0.00470	59.3	0.787	0.000695	2.74	3.57	5.92	140.9
-0.00200	0.00504	61.3	0.812	0.000741	2.70	3.82	5.94	151.2
-0.00210	0.00537	63.0	0.836	0.000786	2.67	4.06	5.95	161.0
-0.00220	0.00568	64.7	0.858	0.000829	2.65	4.29	5.96	170.4
-0.00230	0.00598	66.3	0.879	0.000872	2.64	4.52	5.97	179.4
-0.00240	0.00627	67.8	0.899	0.000913	2.63	4.73	5.97	188.2
-0.00250	0.00655	69.2	0.917	0.000953	2.62	4.95	5.97	196.6
-0.00260	0.00683	70.5	0.936	0.000993	2.62	5.16	5.97	204.9
-0.00270	0.00709	71.8	0.953	0.001031	2.62	5.36	5.97	212.8
-0.00280	0.00735	73.1	0.969	0.001069	2.62	5.55	5.97	220.6
-0.00290	0.00760	74.3	0.985	0.001106	2.62	5.75	5.97	228.1
-0.00300	0.00785	75.4	1.000	0.001142	2.63	5.94	5.96	235.4
SERVICE LOAD LEVEL RESULTS								
-0.00127	0.00240	45.3	0.600	0.000386	3.28	1.86	0.00	72.0
1 ZERO T	=	19.6	K-FT					
1 CRACKING	=	29.1	K-FT					
1 SERVICE	=	45.3	K-FT					
PHI	=	0.900	MU = 67.9 K-FT	MU/(B*H^2) = 0.679	K/IN^2			

TEST SECTION PRESTRESSED AND UNPRESTRESSED  
24-Sep-99

CASE 6A

WIDTH = 12.00 DEPTH = 0.00  
 WIDTH = 12.00 DEPTH = 8.14  
 A = 97.7 I = 539 YT= 4.07 ST= 133 SB= 133  
 CONCRETE STRENGTH = 8.000 KSI DENSITY = 120 PCF TRAPEZOIDAL STRESS BLOCK  
 MODULUS OF RUPTURE = 0.570 KSI  
 E = 3880.0 KSI STRAIN MULTIPLIER = 1  
 SPAN = 20.00 FEET  
 AXIAL LOAD = 0.0 KIPS, COMPRESSION POSITIVE  
 FIBER PROPERTIES, BASED ON NET AREA OF CARBON fu = 450 KSI E= 30000 KSI  
 UNSTRESSED FIBER DATA  
 AREA = 0.0781 DEPTH = 7.73  
 PRESTRESSING DATA EFFECTIVE PRESTRESS fse = 180.00 KSI  
 AREA = 0.3361 DEPTH = 5.29

COMP STRAIN	TENSILE STRAIN	MOMENT K-FT	M/MNOM	CURVATURE RAD/IN	DEPTH OF N. AXIS	DEFL IN	LEVER ARM	FIBER STRESS
-0.00002	-0.00029	0.0	0.000	-0.000035	-0.46	-0.25	0.00	-8.7
0.00000	-0.00029	-0.8	-0.016	-0.000037	0.00	-0.27	-0.16	-8.7
-0.00010	-0.00021	3.5	0.071	-0.000015	-6.53	-0.13	0.70	-6.1
-0.00020	-0.00012	7.8	0.157	0.000010	20.51	0.02	1.56	-3.4
-0.00030	-0.00003	12.2	0.244	0.000034	8.70	0.16	2.41	-0.8
-0.00038	0.00004	15.7	0.315	0.000055	6.97	0.29	3.12	2.4
-0.00044	0.00009	18.1	0.363	0.000069	6.39	0.37	3.60	7.1
-0.00060	0.00043	20.0	0.401	0.000134	4.48	0.58	3.84	13.0
-0.00070	0.00067	21.6	0.433	0.000177	3.95	0.79	4.03	20.0
-0.00080	0.00093	23.2	0.464	0.000224	3.57	1.02	4.18	27.9
-0.00090	0.00122	24.7	0.494	0.000274	3.29	1.26	4.29	36.5
-0.00100	0.00152	26.1	0.523	0.000326	3.07	1.52	4.39	45.6
-0.00110	0.00184	27.6	0.552	0.000381	2.89	1.80	4.47	55.2
-0.00120	0.00217	29.0	0.581	0.000437	2.75	2.09	4.54	65.2
-0.00130	0.00252	30.5	0.610	0.000494	2.63	2.39	4.59	75.6
-0.00140	0.00287	32.0	0.640	0.000553	2.53	2.71	4.64	86.1
-0.00150	0.00323	33.4	0.670	0.000612	2.45	3.04	4.69	96.9
-0.00160	0.00360	34.9	0.699	0.000672	2.38	3.37	4.73	107.9
-0.00170	0.00397	36.4	0.729	0.000733	2.32	3.71	4.76	119.0
-0.00180	0.00434	37.9	0.759	0.000794	2.27	4.06	4.80	130.2
-0.00190	0.00470	39.3	0.787	0.000853	2.23	4.38	4.82	140.9
-0.00200	0.00504	40.6	0.812	0.000911	2.20	4.69	4.83	151.2
-0.00210	0.00537	41.7	0.836	0.000966	2.17	4.99	4.84	161.0
-0.00220	0.00568	42.9	0.858	0.001019	2.16	5.27	4.85	170.3
-0.00230	0.00598	43.9	0.879	0.001071	2.15	5.55	4.86	179.4
-0.00240	0.00627	44.9	0.899	0.001122	2.14	5.82	4.86	188.1
-0.00250	0.00655	45.8	0.917	0.001171	2.13	6.08	4.86	196.6
-0.00260	0.00683	46.7	0.936	0.001220	2.13	6.34	4.86	204.9
-0.00270	0.00709	47.6	0.953	0.001267	2.13	6.58	4.86	212.8
-0.00280	0.00735	48.4	0.969	0.001313	2.13	6.82	4.86	220.5
-0.00290	0.00760	49.2	0.985	0.001359	2.13	7.06	4.86	228.1
-0.00300	0.00785	49.9	1.000	0.001403	2.14	7.30	4.85	235.4
SERVICE LOAD LEVEL RESULTS								
-0.00127	0.00240	30.0	0.600	0.000474	2.67	2.29	0.00	72.0
1 ZERO T	=	13.0 K-FT						
1 CRACKING	=	19.3 K-FT						
1 SERVICE	=	30.0 K-FT						
PHI	=	0.900	MU =	44.9 K-FT	MU/(B*H^2)	=	0.678 K/IN^2	

.2 INCH SLAB ALL STEEL CASE 7 23-Apr-99

WIDTH = 12.00 DEPTH = 0.00  
 WIDTH = 12.00 DEPTH = 12.00  
 A = 144.0 I = 1728 YT= 6.00 ST= 288 SB= 288  
 CONCRETE STRENGTH = 8.000 KSI DENSITY = 120 PCF TRAPEZOIDAL STRESS BLOCK  
 MODULUS OF RUPTURE = 0.570 KSI  
 E = 3880.0 KSI STRAIN MULTIPLIER = 1  
 SPAN = 20.00 FEET  
 AXIAL LOAD = 0.0 KIPS, COMPRESSION POSITIVE  
 UNPRESTRESSED REBAR DATA  
 AREA = 0.2880 DEPTH = 9.75  
 PRESTRESSING DATA EFFECTIVE PRESTRESS fse = 162.00 KSI  
 AREA = 0.5850 DEPTH = 7.80

COMP STRAIN	TENSILE STRAIN	MOMENT K-FT	M/MNOM	CURVATURE RAD/IN	DEPTH OF N. AXIS	DEFL IN	PT STRESS	REBAR STRESS
0.00000	-0.00026	-1.8	-0.019	-0.000027	0.00	-0.19	156.1	-7.5
0.00010	-0.00021	7.5	0.078	-0.000012	-8.20	-0.10	156.9	-5.8
0.00020	-0.00015	16.9	0.174	0.000005	41.09	0.00	157.7	-4.1
0.00030	-0.00009	26.3	0.271	0.000022	13.85	0.10	158.5	-2.3
0.00039	-0.00003	34.7	0.357	0.000037	10.64	0.19	159.5	-0.3
0.00045	0.00001	40.4	0.415	0.000047	9.62	0.25	161.3	2.8
0.00060	0.00023	44.9	0.462	0.000086	7.01	0.38	163.9	6.8
0.00070	0.00040	48.8	0.502	0.000113	6.20	0.52	167.1	11.6
0.00080	0.00059	52.5	0.541	0.000142	5.63	0.66	170.8	17.0
0.00090	0.00079	56.1	0.577	0.000173	5.20	0.82	174.9	22.9
0.00100	0.00100	59.7	0.614	0.000206	4.86	0.98	179.2	29.1
0.00110	0.00123	63.2	0.650	0.000239	4.60	1.15	183.8	35.7
0.00120	0.00147	66.7	0.687	0.000273	4.39	1.34	188.6	42.5
0.00130	0.00171	70.3	0.723	0.000309	4.21	1.53	193.5	49.6
0.00140	0.00196	73.8	0.760	0.000344	4.07	1.72	198.6	56.7
0.00150	0.00223	76.8	0.791	0.000383	3.92	1.91	204.3	60.0
0.00160	0.00253	79.4	0.817	0.000424	3.77	2.08	210.7	60.0
0.00170	0.00284	82.0	0.844	0.000466	3.65	2.28	217.2	60.0
0.00180	0.00316	84.5	0.870	0.000509	3.54	2.49	223.8	60.0
0.00190	0.00346	86.9	0.894	0.000550	3.45	2.68	230.1	60.0
0.00200	0.00375	89.0	0.916	0.000590	3.39	2.87	236.2	60.0
0.00210	0.00403	91.0	0.936	0.000629	3.34	3.06	241.9	60.0
0.00220	0.00432	92.5	0.952	0.000669	3.29	3.22	246.5	60.0
0.00230	0.00464	93.6	0.963	0.000712	3.23	3.35	249.4	60.0
0.00240	0.00497	94.4	0.971	0.000756	3.18	3.47	251.6	60.0
0.00250	0.00530	95.1	0.978	0.000800	3.12	3.59	253.5	60.0
0.00260	0.00564	95.6	0.984	0.000845	3.08	3.71	255.0	60.0
0.00270	0.00598	96.1	0.989	0.000890	3.03	3.82	256.3	60.0
0.00280	0.00632	96.5	0.993	0.000935	2.99	3.92	257.4	60.0
0.00290	0.00666	96.9	0.997	0.000980	2.96	4.02	258.3	60.0
0.00300	0.00700	97.2	1.000	0.001026	2.92	4.12	259.1	60.0

SERVICE LOAD LEVEL RESULTS

0.00034 -0.00006 30.0 0.309 0.000028 12.42 0.14 158.9 -1.4  
 ZERO T = 30.0 K-FT MZO/MSR = 1.000 MZO/MN = 0.309  
 CRACKING = 43.7 K-FT MCR/MSR = 1.456 MCR/MN = 0.450  
 SERVICE = 30.0 K-FT MSR/MN = 0.309  
 HI = 0.900 MU = 87.5 K-FT MU/(B\*H^2) = 0.607 K/IN^2



3.4 INCH SLAB ALL STEEL CASE 7B 23-Apr-99

WIDTH = 12.00 DEPTH = 0.00  
 WIDTH = 12.00 DEPTH = 13.40  
 A = 160.8 I = 2406 YT= 6.70 ST= 359 SB= 359  
 CONCRETE STRENGTH = 8.000 KSI DENSITY = 120 PCF TRAPEZOIDAL STRESS BLOCK  
 MODULUS OF RUPTURE = 0.570 KSI  
 E = 3880.0 KSI STRAIN MULTIPLIER = 1  
 SPAN = 20.00 FEET  
 AXIAL LOAD = 0.0 KIPS, COMPRESSION POSITIVE  
 UNPRESTRESSED REBAR DATA  
 AREA = 0.3216 DEPTH = 11.15  
 PRESTRESSING DATA EFFECTIVE PRESTRESS fse = 162.00 KSI  
 AREA = 0.5240 DEPTH = 8.71

COMP STRAIN	TENSILE STRAIN	MOMENT K-FT	M/MNOM	CURVATURE RAD/IN	DEPTH OF N. AXIS	DEFL IN	PT STRESS	REBAR STRESS
0.00000	-0.00021	-1.9	-0.018	-0.000019	0.00	-0.14	157.2	-6.2
0.00010	-0.00016	9.8	0.094	-0.000006	-17.32	-0.05	158.0	-4.4
0.00020	-0.00009	21.5	0.206	0.000009	21.19	0.03	158.8	-2.5
0.00030	-0.00003	32.8	0.314	0.000024	12.39	0.12	159.7	-0.6
0.00036	0.00001	40.4	0.387	0.000034	10.74	0.18	161.4	2.5
0.00041	0.00005	45.9	0.439	0.000041	10.04	0.22	164.1	6.8
0.00060	0.00042	50.6	0.485	0.000091	6.57	0.37	167.6	12.1
0.00070	0.00063	55.1	0.527	0.000119	5.88	0.53	171.6	18.2
0.00080	0.00086	59.4	0.569	0.000149	5.38	0.69	176.1	24.8
0.00090	0.00110	63.7	0.610	0.000179	5.01	0.85	180.9	31.9
0.00100	0.00136	68.0	0.651	0.000211	4.73	1.02	186.0	39.4
0.00110	0.00162	72.4	0.693	0.000244	4.51	1.20	191.3	47.1
0.00120	0.00190	76.7	0.734	0.000278	4.32	1.39	196.7	55.0
0.00130	0.00219	80.6	0.771	0.000313	4.15	1.56	202.7	60.0
0.00140	0.00254	83.5	0.799	0.000353	3.97	1.73	209.7	60.0
0.00150	0.00289	86.4	0.827	0.000394	3.81	1.91	217.0	60.0
0.00160	0.00325	89.3	0.855	0.000435	3.68	2.11	224.4	60.0
0.00170	0.00362	92.2	0.883	0.000477	3.56	2.31	232.1	60.0
0.00180	0.00400	95.2	0.911	0.000520	3.46	2.53	239.8	60.0
0.00190	0.00438	97.6	0.934	0.000563	3.37	2.72	246.3	60.0
0.00200	0.00480	99.1	0.949	0.000610	3.28	2.87	250.0	60.0
0.00210	0.00524	100.3	0.960	0.000658	3.19	3.01	252.7	60.0
0.00220	0.00568	101.2	0.968	0.000707	3.11	3.14	254.8	60.0
0.00230	0.00613	101.9	0.975	0.000756	3.04	3.26	256.5	60.0
0.00240	0.00658	102.5	0.981	0.000805	2.98	3.38	257.9	60.0
0.00250	0.00703	103.0	0.986	0.000855	2.92	3.49	259.0	60.0
0.00260	0.00748	103.4	0.989	0.000904	2.88	3.60	259.9	60.0
0.00270	0.00795	103.7	0.993	0.000955	2.83	3.70	260.7	60.0
0.00280	0.00840	104.0	0.995	0.001005	2.79	3.80	261.4	60.0
0.00290	0.00885	104.3	0.998	0.001054	2.75	3.89	261.9	60.0
0.00300	0.00932	104.5	1.000	0.001105	2.71	3.99	262.5	60.0

SERVICE LOAD LEVEL RESULTS

0.00027 -0.00005 30.0 0.287 0.000020 14.58 0.10 159.5 -1.1  
 ZERO T = 30.0 K-FT MZO/MSR = 1.000 MZO/MN = 0.287  
 CRACKING = 47.1 K-FT MCR/MSR = 1.568 MCR/MN = 0.451  
 SERVICE = 30.0 K-FT MSR/MN = 0.287  
 HI = 0.900 MU = 94.0 K-FT MU/(B\*H^2) = 0.524 K/IN^2

10 INCH SLAB ALL STEEL CASE 8 23-Apr-99

WIDTH = 12.00 DEPTH = 0.00  
 WIDTH = 12.00 DEPTH = 10.00  
 A = 120.0 I = 1000 YT= 5.00 ST= 200 SB= 200  
 CONCRETE STRENGTH = 8.000 KSI DENSITY = 120 PCF TRAPEZOIDAL STRESS BLOCK  
 MODULUS OF RUPTURE = 0.570 KSI  
 E = 3880.0 KSI STRAIN MULTIPLIER = 1  
 SPAN = 20.00 FEET  
 AXIAL LOAD = 0.0 KIPS, COMPRESSION POSITIVE  
 UNPRESTRESSED REBAR DATA  
 AREA = 0.2400 DEPTH = 7.75  
 PRESTRESSING DATA EFFECTIVE PRESTRESS fse = 162.00 KSI  
 AREA = 0.7020 DEPTH = 6.50

COMP STRAIN	TENSILE STRAIN	MOMENT K-FT	M/MNOM	CURVATURE RAD/IN	DEPTH OF N. AXIS	DEFL IN	PT STRESS	REBAR STRESS
0.00000	-0.00035	-1.7	-0.020	-0.000045	0.00	-0.32	153.6	-10.2
-0.00010	-0.00032	4.8	0.057	-0.000029	-3.36	-0.22	154.4	-8.7
-0.00020	-0.00027	11.3	0.134	-0.000009	-21.76	-0.11	155.2	-7.2
-0.00030	-0.00021	17.8	0.211	0.000011	27.32	0.01	156.0	-5.7
-0.00040	-0.00016	24.2	0.288	0.000031	12.87	0.13	156.7	-4.1
-0.00050	-0.00010	30.6	0.365	0.000051	9.81	0.25	157.6	-2.6
-0.00058	-0.00006	35.6	0.424	0.000066	8.68	0.34	158.8	-0.5
-0.00070	0.00008	39.6	0.471	0.000101	6.96	0.48	160.7	2.3
-0.00080	0.00020	42.9	0.510	0.000129	6.22	0.61	163.0	5.7
-0.00090	0.00033	45.9	0.545	0.000159	5.66	0.76	165.8	9.6
-0.00100	0.00048	48.6	0.579	0.000191	5.24	0.91	168.9	13.9
-0.00110	0.00064	51.3	0.611	0.000225	4.90	1.07	172.3	18.6
-0.00120	0.00081	53.9	0.642	0.000260	4.62	1.24	175.9	23.5
-0.00130	0.00099	56.5	0.673	0.000296	4.40	1.42	179.7	28.8
-0.00140	0.00118	59.1	0.703	0.000333	4.21	1.61	183.7	34.2
-0.00150	0.00137	61.7	0.734	0.000370	4.05	1.81	187.9	39.7
-0.00160	0.00157	64.2	0.764	0.000409	3.91	2.01	192.1	45.5
-0.00170	0.00177	66.8	0.795	0.000448	3.80	2.22	196.5	51.3
-0.00180	0.00197	69.4	0.825	0.000487	3.70	2.44	200.9	57.2
-0.00190	0.00218	71.4	0.850	0.000527	3.61	2.62	205.4	60.0
-0.00200	0.00239	73.1	0.869	0.000567	3.53	2.79	210.0	60.0
-0.00210	0.00259	74.5	0.887	0.000606	3.47	2.96	214.3	60.0
-0.00220	0.00279	75.9	0.903	0.000644	3.42	3.12	218.5	60.0
-0.00230	0.00298	77.2	0.918	0.000681	3.38	3.28	222.6	60.0
-0.00240	0.00316	78.4	0.932	0.000717	3.35	3.44	226.4	60.0
-0.00250	0.00333	79.5	0.946	0.000753	3.32	3.60	230.2	60.0
-0.00260	0.00351	80.5	0.958	0.000788	3.30	3.75	233.8	60.0
-0.00270	0.00367	81.5	0.970	0.000822	3.28	3.90	237.4	60.0
-0.00280	0.00383	82.5	0.981	0.000856	3.27	4.05	240.7	60.0
-0.00290	0.00399	83.4	0.992	0.000889	3.26	4.20	244.0	60.0
-0.00300	0.00417	84.1	1.000	0.000925	3.24	4.32	246.4	60.0

SERVICE LOAD LEVEL RESULTS  
 0.00049 -0.00011 30.0 0.357 0.000049 10.11 0.24 157.5 -2.8  
 ZERO T = 30.0 K-FT MZO/MSR = 1.000 MZO/MN = 0.357  
 CRACKING = 39.5 K-FT MCR/MSR = 1.317 MCR/MN = 0.470  
 SERVICE = 30.0 K-FT MSR/MN = 0.357  
 HI = 0.843 MU = 70.9 K-FT MU/(B\*H^2) = 0.709 K/IN^2

3 INCH SLAB ALL STEEL CASE 9 23-Apr-99

WIDTH = 12.00 DEPTH = 0.00  
 WIDTH = 12.00 DEPTH = 8.00  
 A = 96.0 I = 512 YT= 4.00 ST= 128 SB= 128  
 CONCRETE STRENGTH = 8.000 KSI DENSITY = 120 PCF TRAPEZOIDAL STRESS BLOCK  
 MODULUS OF RUPTURE = 0.570 KSI  
 J = 3880.0 KSI STRAIN MULTIPLIER = 1  
 SPAN = 20.00 FEET  
 AXIAL LOAD = 0.0 KIPS, COMPRESSION POSITIVE  
 UNPRESTRESSED REBAR DATA  
 AREA = 0.1920 DEPTH = 5.75  
 PRESTRESSING DATA EFFECTIVE PRESTRESS fse = 162.00 KSI  
 AREA = 0.8770 DEPTH = 5.20

COMP STRAIN	TENSILE STRAIN	MOMENT K-FT	M/MNOM	CURVATURE RAD/IN	DEPTH OF N. AXIS	DEFL IN	PT STRESS	REBAR STRESS
0.000000	-0.00049	-1.5	-0.024	-0.000086	0.00	-0.62	149.3	-14.3
-0.00010	-0.00050	2.6	0.040	-0.000070	-1.44	-0.52	150.0	-13.2
-0.00020	-0.00046	6.7	0.105	-0.000045	-4.44	-0.37	150.8	-12.0
-0.00030	-0.00042	10.9	0.169	-0.000020	-14.91	-0.22	151.6	-10.8
-0.00040	-0.00037	15.0	0.233	0.000005	83.21	-0.07	152.3	-9.7
-0.00050	-0.00033	19.1	0.297	0.000030	16.79	0.08	153.1	-8.5
-0.00060	-0.00029	23.3	0.362	0.000055	10.96	0.23	153.8	-7.3
-0.00070	-0.00024	27.4	0.426	0.000080	8.78	0.38	154.6	-6.2
-0.00079	-0.00020	31.3	0.486	0.000103	7.70	0.52	155.5	-4.9
-0.00087	-0.00017	34.4	0.535	0.000122	7.12	0.63	156.8	-3.1
-0.00100	-0.00003	37.1	0.577	0.000168	5.96	0.80	158.4	-1.0
-0.00110	0.00005	39.5	0.614	0.000200	5.50	0.96	160.3	1.4
-0.00120	0.00015	41.7	0.648	0.000234	5.13	1.13	162.5	4.2
-0.00130	0.00025	43.8	0.680	0.000269	4.82	1.30	164.9	7.2
-0.00140	0.00036	45.7	0.710	0.000306	4.57	1.47	167.5	10.5
-0.00150	0.00048	47.6	0.740	0.000345	4.35	1.66	170.3	13.9
-0.00160	0.00061	49.5	0.768	0.000384	4.17	1.85	173.3	17.6
-0.00170	0.00074	51.3	0.797	0.000424	4.01	2.05	176.4	21.4
-0.00180	0.00087	53.1	0.824	0.000464	3.88	2.26	179.5	25.2
-0.00190	0.00100	54.6	0.848	0.000504	3.77	2.45	182.6	29.0
-0.00200	0.00112	56.0	0.869	0.000543	3.68	2.63	185.5	32.5
-0.00210	0.00124	57.2	0.888	0.000581	3.62	2.80	188.2	35.9
-0.00220	0.00135	58.2	0.904	0.000618	3.56	2.96	190.8	39.2
-0.00230	0.00146	59.2	0.920	0.000654	3.52	3.12	193.4	42.3
-0.00240	0.00156	60.1	0.934	0.000689	3.48	3.27	195.7	45.3
-0.00250	0.00166	61.0	0.947	0.000724	3.45	3.42	198.1	48.2
-0.00260	0.00176	61.7	0.959	0.000758	3.43	3.57	200.3	51.1
-0.00270	0.00185	62.5	0.970	0.000792	3.41	3.72	202.4	53.8
-0.00280	0.00195	63.2	0.981	0.000825	3.39	3.86	204.5	56.4
-0.00290	0.00203	63.8	0.991	0.000858	3.38	4.00	206.5	59.0
-0.00300	0.00213	64.4	1.000	0.000891	3.37	4.13	208.6	60.0

SERVICE LOAD LEVEL RESULTS

-0.00076 -0.00021 30.0 0.466 0.000095 8.06 0.47 155.2 -5.3  
 1 ZERO T = 30.0 K-FT MZO/MSR = 1.000 MZO/MN = 0.466  
 1 CRACKING = 36.1 K-FT MCR/MSR = 1.203 MCR/MN = 0.560  
 1 SERVICE = 30.0 K-FT MSR/MN = 0.466  
 PHI = 0.705 MU = 45.4 K-FT MU/(B\*H^2) = 0.709 K/IN^2

13.4 INCH SLAB STEEL+CARBON

CASE 10

24-Sep-99

WIDTH = 12.00 DEPTH = 0.00

WIDTH = 12.00 DEPTH = 13.40

A = 160.8 I = 2406 YT= 6.70 ST= 359 SB= 359

CONCRETE STRENGTH = 8.000 KSI DENSITY = 120 PCF TRAPEZOIDAL STRESS BLOCK

MODULUS OF RUPTURE = 0.570 KSI

E = 3880.0 KSI STRAIN MULTIPLIER = 1

SPAN = 20.00 FEET

AXIAL LOAD = 0.0 KIPS, COMPRESSION POSITIVE

FIBER PROPERTIES, BASED ON NET AREA OF CARBON fu = 450 KSI E = 30000 KSI

UNPRESTRESSED FIBER DATA

AREA = 0.1287 DEPTH = 12.73

PRESTRESSING DATA EFFECTIVE PRESTRESS fse = 162.00 KSI

AREA = 0.1581 DEPTH = 8.71

COMP STRAIN	TENSILE STRAIN	MOMENT K-FT	M/MNOM	CURVATURE RAD/IN	DEPTH OF N. AXIS	DEFL IN	PT STRESS	FIBER STRESS
0.00000	-0.00008	-0.6	-0.007	-0.000006	0.00	-0.04	160.5	-2.3
0.00010	0.00001	10.8	0.125	0.000008	11.62	0.04	161.4	0.5
0.00014	0.00005	15.6	0.180	0.000014	9.54	0.08	164.9	7.2
0.00017	0.00007	18.7	0.216	0.000019	8.92	0.10	171.1	18.2
0.00019	0.00009	21.8	0.252	0.000022	8.53	0.13	179.1	31.9
0.00022	0.00012	25.0	0.289	0.000027	8.25	0.15	188.1	47.1
0.00060	0.00211	28.2	0.327	0.000213	2.82	0.70	197.7	63.2
0.00070	0.00267	31.6	0.366	0.000264	2.65	1.16	207.7	80.0
0.00080	0.00324	35.0	0.405	0.000317	2.52	1.53	217.9	97.2
0.00090	0.00382	38.4	0.445	0.000371	2.43	1.88	228.4	114.6
0.00100	0.00441	41.9	0.485	0.000425	2.35	2.22	238.9	132.2
0.00110	0.00503	45.3	0.524	0.000481	2.29	2.56	247.5	150.8
0.00120	0.00570	48.4	0.561	0.000542	2.21	2.89	251.8	170.9
0.00130	0.00640	51.6	0.597	0.000605	2.15	3.24	254.9	192.1
0.00140	0.00712	54.7	0.634	0.000669	2.09	3.60	257.2	213.6
0.00150	0.00786	57.8	0.670	0.000735	2.04	3.97	258.8	235.7
0.00160	0.00860	61.0	0.706	0.000802	2.00	4.35	260.2	258.1
0.00170	0.00936	64.1	0.742	0.000868	1.96	4.73	261.2	280.7
0.00180	0.01012	67.2	0.779	0.000936	1.92	5.12	262.1	303.6
0.00190	0.01085	70.1	0.812	0.001001	1.90	5.49	262.7	325.4
0.00200	0.01155	72.9	0.845	0.001064	1.88	5.85	263.3	346.4
0.00210	0.01221	75.6	0.875	0.001124	1.87	6.19	263.7	366.4
0.00220	0.01285	78.0	0.904	0.001182	1.86	6.52	264.1	385.5
0.00230	0.01347	80.4	0.932	0.001239	1.86	6.84	264.4	404.1
0.00240	0.01407	82.7	0.958	0.001293	1.86	7.15	264.7	422.0
0.00250	0.01464	84.9	0.984	0.001346	1.86	7.45	264.9	439.2
0.00260	0.01535	86.3	1.000	0.001410	1.84	7.68	265.2	450.0

RUPTURE OF UNSTRESSED FIBER

SERVICE LOAD LEVEL RESULTS

0.00065 0.00240 30.0 0.347 0.000240 2.73 0.94 202.9 72.0

ZERO T = 9.1 K-FT MZO/MSR = 0.302 MZO/MN = 0.105

CRACKING = 26.1 K-FT MCR/MSR = 0.871 MCR/MN = 0.303

SERVICE = 30.0 K-FT MSR/MN = 0.347

HI = 0.900 MU = 77.7 K-FT MU/(B\*H^2) = 0.433 K/IN^2

2 INCH SLAB STEEL+CARBON CASE 10B 24-Sep-99

IDTH = 12.00 DEPTH = 0.00  
 IDTH = 12.00 DEPTH = 12.00  
 A = 144.0 I = 1728 YT= 6.00 ST= 288 SB= 288  
 CONCRETE STRENGTH = 8.000 KSI DENSITY = 120 PCF TRAPEZOIDAL STRESS BLOCK  
 MODULUS OF RUPTURE = 0.570 KSI  
 = 3880.0 KSI STRAIN MULTIPLIER = 1  
 PAN = 20.00 FEET  
 AXIAL LOAD = 0.0 KIPS, COMPRESSION POSITIVE  
 FIBER PROPERTIES, BASED ON NET AREA OF CARBON fu = 450 KSI E = 30000 KSI  
 PRESTRESSED FIBER DATA  
 REA = 0.1152 DEPTH = 11.40  
 RESTRESSING DATA EFFECTIVE PRESTRESS fse = 162.00 KSI  
 REA = 0.1957 DEPTH = 7.80

COMP STRAIN	TENSILE STRAIN	MOMENT K-FT	M/MNOM	CURVATURE RAD/IN	DEPTH OF N. AXIS	DEFL IN	PT STRESS	FIBER STRESS
0.00000	-0.00011	-0.6	-0.008	-0.000009	0.00	-0.07	159.9	-3.2
0.00010	-0.00002	8.8	0.114	0.000007	13.89	0.03	160.8	-0.5
0.00017	0.00004	14.9	0.193	0.000018	9.13	0.10	162.7	3.9
0.00020	0.00007	17.9	0.233	0.000024	8.40	0.13	167.1	12.0
0.00023	0.00010	20.6	0.267	0.000028	8.01	0.16	173.3	22.9
0.00025	0.00012	23.1	0.300	0.000033	7.72	0.19	180.6	35.5
0.00060	0.00164	25.8	0.334	0.000197	3.05	0.65	188.6	49.3
0.00070	0.00213	28.5	0.369	0.000248	2.82	1.06	197.2	63.9
0.00080	0.00263	31.2	0.405	0.000301	2.66	1.41	206.2	79.0
0.00090	0.00315	34.0	0.441	0.000355	2.53	1.75	215.4	94.6
0.00100	0.00368	36.8	0.478	0.000410	2.44	2.09	224.8	110.4
0.00110	0.00421	39.7	0.514	0.000466	2.36	2.42	234.3	126.4
0.00120	0.00476	42.5	0.552	0.000522	2.30	2.76	243.9	142.7
0.00130	0.00536	45.2	0.585	0.000584	2.23	3.09	249.4	160.7
0.00140	0.00600	47.7	0.618	0.000649	2.16	3.44	253.0	180.1
0.00150	0.00667	50.2	0.650	0.000716	2.09	3.79	255.6	200.0
0.00160	0.00736	52.6	0.682	0.000786	2.04	4.16	257.6	220.8
0.00170	0.00806	55.1	0.714	0.000856	1.99	4.54	259.1	241.7
0.00180	0.00878	57.5	0.746	0.000928	1.94	4.94	260.3	263.3
0.00190	0.00946	59.8	0.776	0.000997	1.91	5.32	261.2	283.9
0.00200	0.01012	62.0	0.803	0.001063	1.88	5.68	262.0	303.5
0.00210	0.01075	64.0	0.830	0.001127	1.86	6.03	262.6	322.6
0.00220	0.01136	65.9	0.855	0.001190	1.85	6.37	263.1	340.8
0.00230	0.01196	67.8	0.879	0.001251	1.84	6.71	263.5	358.8
0.00240	0.01253	69.6	0.902	0.001309	1.83	7.03	263.8	375.8
0.00250	0.01309	71.3	0.925	0.001368	1.83	7.35	264.2	392.7
0.00260	0.01362	72.9	0.946	0.001423	1.83	7.66	264.4	408.6
0.00270	0.01415	74.5	0.967	0.001478	1.83	7.96	264.7	424.5
0.00280	0.01466	76.1	0.987	0.001532	1.83	8.26	264.9	439.8
0.00290	0.01525	77.1	1.000	0.001592	1.82	8.49	265.1	450.0

RUPTURE OF UNSTRESSED FIBER

SERVICE LOAD LEVEL RESULTS

0.00075	0.00240	30.0	0.388	0.000277	2.73	1.25	202.0	72.0
ZERO T =	10.0 K-FT	MZO/MSR = 0.335	MZO/MN = 0.130					
CRACKING =	23.7 K-FT	MCR/MSR = 0.792	MCR/MN = 0.308					
SERVICE =	30.0 K-FT	MSR/MN = 0.388						
MI = 0.900	MU = 69.4 K-FT	MU/(B*H^2) = 0.482 K/IN^2						

10 INCH SLAB STEEL+CARBON CASE 11

24-Sep-99

WIDTH = 12.00 DEPTH = 0.00  
 WIDTH = 12.00 DEPTH = 10.00  
 A = 120.0 I = 1000 YT= 5.00 ST= 200 SB= 200  
 CONCRETE STRENGTH = 8.000 KSI DENSITY = 120 PCF TRAPEZOIDAL STRESS BLOCK  
 MODULUS OF RUPTURE = 0.570 KSI  
 E = 3880.0 KSI STRAIN MULTIPLIER = 1  
 SPAN = 20.00 FEET  
 AXIAL LOAD = 0.0 KIPS, COMPRESSION POSITIVE  
 FIBER PROPERTIES, BASED ON NET AREA OF CARBON fu = 450 KSI E = 30000 KSI  
 PRESTRESSED FIBER DATA  
 REA = 0.0960 DEPTH = 9.50  
 RESTRESSING DATA EFFECTIVE PRESTRESS fse = 162.00 KSI  
 REA = 0.2683 DEPTH = 6.50

COMP STRAIN	TENSILE STRAIN	MOMENT K-FT	M/MNOM	CURVATURE RAD/IN	DEPTH OF N. AXIS	DEFL IN	PT STRESS	FIBER STRESS
0.00000	-0.00017	-0.7	-0.012	-0.000018	0.00	-0.13	158.7	-5.2
0.00010	-0.00009	5.8	0.096	0.000001	83.66	-0.01	159.5	-2.5
0.00020	0.00000	12.3	0.203	0.000021	9.42	0.11	160.3	0.2
0.00026	0.00006	16.2	0.268	0.000033	7.79	0.18	162.3	4.6
0.00030	0.00009	18.8	0.310	0.000041	7.27	0.23	165.7	11.3
0.00033	0.00012	20.9	0.344	0.000048	6.96	0.27	170.4	19.8
0.00060	0.00099	22.8	0.377	0.000167	3.58	0.59	175.9	29.7
0.00070	0.00135	24.8	0.410	0.000216	3.24	0.91	182.1	40.6
0.00080	0.00174	26.8	0.442	0.000268	2.99	1.20	188.8	52.3
0.00090	0.00215	28.8	0.475	0.000321	2.80	1.50	195.8	64.5
0.00100	0.00257	30.8	0.509	0.000376	2.66	1.81	203.1	77.1
0.00110	0.00300	32.9	0.543	0.000432	2.55	2.13	210.7	90.1
0.00120	0.00345	34.9	0.577	0.000489	2.45	2.46	218.4	103.4
0.00130	0.00390	37.0	0.611	0.000547	2.38	2.79	226.3	116.9
0.00140	0.00435	39.1	0.646	0.000605	2.31	3.13	234.2	130.5
0.00150	0.00481	41.2	0.681	0.000664	2.26	3.48	242.3	144.3
0.00160	0.00532	43.2	0.713	0.000728	2.20	3.81	248.0	159.5
0.00170	0.00587	44.9	0.742	0.000797	2.13	4.15	251.5	176.1
0.00180	0.00645	46.7	0.770	0.000869	2.07	4.50	254.2	193.6
0.00190	0.00702	48.2	0.796	0.000939	2.02	4.85	256.2	210.7
0.00200	0.00758	49.6	0.820	0.001009	1.98	5.18	257.7	227.4
0.00210	0.00812	51.0	0.842	0.001075	1.95	5.51	258.8	243.5
0.00220	0.00865	52.2	0.862	0.001142	1.93	5.83	259.8	259.4
0.00230	0.00917	53.4	0.882	0.001207	1.91	6.16	260.5	275.0
0.00240	0.00966	54.6	0.901	0.001270	1.89	6.47	261.2	289.9
0.00250	0.01016	55.7	0.919	0.001332	1.88	6.78	261.7	304.7
0.00260	0.01063	56.7	0.936	0.001393	1.87	7.09	262.2	318.9
0.00270	0.01110	57.7	0.953	0.001453	1.86	7.39	262.6	333.1
0.00280	0.01155	58.7	0.969	0.001511	1.85	7.69	263.0	346.6
0.00290	0.01200	59.6	0.985	0.001569	1.85	7.98	263.3	360.1
0.00300	0.01244	60.6	1.000	0.001626	1.85	8.28	263.6	373.3

SERVICE LOAD LEVEL RESULTS

0.00096 0.00240 30.0 0.495 0.000354 2.72 1.69 200.2 72.0  
 ZERO T = 11.5 K-FT MZO/MSR = 0.382 MZO/MN = 0.189  
 CRACKING = 21.0 K-FT MCR/MSR = 0.699 MCR/MN = 0.346  
 SERVICE = 30.0 K-FT MSR/MN = 0.495  
 HI = 0.900 MU = 54.5 K-FT MU/(B\*H^2) = 0.545 K/IN^2

.14 INCH SLAB STEEL+CARBON

CASE 12

24-Sep-99

IDTH = 12.00 DEPTH = 0.00

IDTH = 12.00 DEPTH = 8.14

A = 97.7 I = 539 YT= 4.07 ST= 133 SB= 133

ONCRETE STRENGTH = 8.000 KSI DENSITY = 120 PCF TRAPEZOIDAL STRESS BLOCK

ODULUS OF RUPTURE = 0.570 KSI

= 3880.0 KSI STRAIN MULTIPLIER = 1

PAN = 20.00 FEET

XIAL LOAD = 0.0 KIPS, COMPRESSION POSITIVE

IBER PROPERTIES, BASED ON NET AREA OF CARBON fu = 450 KSI E = 30000 KSI

NPRESTRESSED FIBER DATA

REA = 0.0781 DEPTH = 7.73

RESTRESSING DATA EFFECTIVE PRESTRESS fse = 162.00 KSI

REA = 0.3715 DEPTH = 5.29

COMP STRAIN	TENSILE STRAIN	MOMENT K-FT	M/MNOM	CURVATURE RAD/IN	DEPTH OF N. AXIS	DEFL IN	PT STRESS	FIBER STRESS
0.00000	-0.00029	-0.8	-0.016	-0.000037	0.00	-0.27	156.4	-8.6
0.00010	-0.00021	3.5	0.074	-0.000015	-6.62	-0.13	157.2	-6.0
0.00020	-0.00012	7.9	0.164	0.000010	20.05	0.02	158.0	-3.4
0.00030	-0.00003	12.2	0.254	0.000035	8.65	0.17	158.8	-0.8
0.00038	0.00004	15.7	0.328	0.000055	6.95	0.29	160.0	2.5
0.00044	0.00009	18.1	0.377	0.000069	6.38	0.37	162.2	7.2
0.00060	0.00044	20.0	0.416	0.000134	4.47	0.58	165.2	13.2
0.00070	0.00067	21.6	0.450	0.000177	3.95	0.80	168.8	20.1
0.00080	0.00093	23.2	0.482	0.000224	3.57	1.02	173.0	28.0
0.00090	0.00122	24.6	0.514	0.000274	3.29	1.26	177.6	36.5
0.00100	0.00152	26.1	0.544	0.000326	3.07	1.52	182.6	45.6
0.00110	0.00184	27.6	0.575	0.000380	2.89	1.80	187.9	55.1
0.00120	0.00217	29.1	0.606	0.000436	2.75	2.09	193.5	65.0
0.00130	0.00251	30.5	0.637	0.000492	2.64	2.40	199.2	75.2
0.00140	0.00286	32.0	0.668	0.000550	2.54	2.71	205.1	85.7
0.00150	0.00321	33.5	0.699	0.000609	2.46	3.04	211.1	96.3
0.00160	0.00357	35.0	0.730	0.000669	2.39	3.37	217.3	107.1
0.00170	0.00394	36.6	0.762	0.000729	2.33	3.71	223.5	118.1
0.00180	0.00430	38.1	0.794	0.000790	2.28	4.05	229.8	129.1
0.00190	0.00466	39.5	0.822	0.000848	2.24	4.37	235.7	139.7
0.00200	0.00499	40.8	0.849	0.000905	2.21	4.68	241.4	149.8
0.00210	0.00533	41.9	0.873	0.000961	2.18	4.96	246.0	159.9
0.00220	0.00569	42.8	0.892	0.001021	2.15	5.22	248.8	170.8
0.00230	0.00606	43.6	0.909	0.001081	2.13	5.47	251.0	181.8
0.00240	0.00642	44.4	0.924	0.001141	2.10	5.72	252.8	192.6
0.00250	0.00678	45.1	0.939	0.001201	2.08	5.97	254.2	203.4
0.00260	0.00714	45.7	0.952	0.001260	2.06	6.22	255.5	214.2
0.00270	0.00749	46.3	0.965	0.001319	2.05	6.47	256.5	224.8
0.00280	0.00785	46.9	0.977	0.001377	2.03	6.72	257.4	235.4
0.00290	0.00819	47.4	0.989	0.001435	2.02	6.96	258.1	245.7
0.00300	0.00853	48.0	1.000	0.001492	2.01	7.21	258.8	256.0
SERVICE LOAD LEVEL RESULTS								
0.00118	0.00211	28.8	0.600	0.000425	2.78	2.04	192.4	63.2
ZERO T =	12.9 K-FT	MZO/MSR = 0.449	MZO/MN = 0.269					
CRACKING=	19.2 K-FT	MCR/MSR = 0.668	MCR/MN = 0.401					
SERVICE =	28.8 K-FT	MSR/MN = 0.600						
HI = 0.900	MU = 43.2 K-FT	MU/(B*H^2) = 0.652 K/IN^2						

## **APPENDIX D**

The attached spreadsheet was used to develop the preliminary hydrostatic properties of the proposed floating pier concept.

It was also used to determine the structural concrete quantities in the pier and to estimate the quantities of CFRP materials required (following hydrostatics spreadsheet).



PROJECT: NFESC FRP Concrete Composite Pier  
 SUBJECT: Weight and Center of Gravity Calculation  
 DESIGNER: ESD  
 DATE: 9-Nov-94  
 REVISED: 23-Sep-99

**PONTOON - DELIVERY VOYAGE - TRANSPORT 1**  
 Without Building and Equipment

THIN WALLS AND SLABS III  
 LTWT CONCRETE (120 pcf) - REINF

GROSS PARAMETERS:

**SUMMARY**

Water Density	64 pcf
LTWT Concrete Density	120 pcf
Keel Slab Concrete Density	126.3
Top Slab Concrete Density	124.4
Intermediate Slab Concrete Density	124.4
Interior Walls Concrete Density	120
Exterior Walls Concrete Density	125.3
Avg Reinforced Concrete Density - A	124.1 pcf
Volume Concrete	23,175 cyd
Weight Steel Reinf.	1,295 tons

Pontoon Depth: 28 ft (z) - depth at centre of pier  
 Length: 1,400 ft (y)

Width: 94 ft (x)  
 Lower Deck Height: 16 ft

WEIGHT AND CG - PONTOON

ELEMENT	# UNITS	THICK (in)	LENGTH (ft)	WIDTH (ft)	VOLUME (ft <sup>3</sup> )	UNIT WT (pcf)	WEIGHT (kips)	INCR DRAFT (ft)	X (ft)	Y (ft)	Z (ft)	Wx (kip-ft)	Wy (kip-ft)	Wz (kip-ft)	
<b>PONTOON KEELSLAB</b>															
Cip	1	8.00	1,370.00	94.000	85,853	126.3	10,843	1.287	47.00	700.00	0.33	509,634	7,580,283	3,614	
Exter Haunch Longit	2	5.00	1,360.000	6.160	6,981	126.3	882	0.105	47.00	700.00	0.88	41,442	617,220	772	
Inler Haunch Longit	8	12.00	1,360.000	0.886	9,642	126.3	1,218	0.145	47.00	700.00	0.79	57,235	852,436	965	
Transverse Interior Haunch	24	12.00	78.000	0.886	1,659	126.3	210	0.025	47.00	700.00	0.79	9,848	146,669	166	
<b>PONTOON DECK SLAB</b>															
Precast Panels	4	15.00	1,400.00	20.000	140,000	124.4	17,416	2.068	47.00	700.00	26.38	818,552	12,191,200	459,347	
Inler Haunch	8	12.00	1,370.000	1.045	11,453	124.4	1,425	0.169	47.00	700.00	26.60	66,965	997,345	37,899	
Exterior Section	2	24.00	1,400.000	5.000	28,000	124.4	3,483	0.414	47.00	700.00	27.00	163,710	243,8240	94,046	
Intermediate deck	2	12.00	1,400.000	26.667	74,666	124.4	9,289	1.103	47.00	700.00	15.50	436,560	6,501,957	143,972	
<b>PONTOON WALLS</b>															
Trans End Walls - top	6	10.00	40.500	12.000	2,430	125.3	304	0.036	47.00	700.00	21.00	14,311	213,135	6,394	
Trans End Walls - lower	6	10.00	94.000	14.333	6,737	125.3	844	0.100	47.00	700.00	7.63	39,673	590,873	6,612	
Long Ext Walls	2	10.00	1,396.00	13.893	31,162	125.3	3,905	0.464	47.00	700.00	7.36	183,515	2,733,203	28,751	
Full Ht. Longt. Walls upper	2	16.00	1,399.00	10.750	40,105	125.3	5,025	0.597	47.00	700.00	6.04	236,180	3,517,580	30,360	
Full Ht. Longt. Walls lower	2	8.00	1,399.00	14.833	27,856	120	3,343	0.397	47.00	700.00	7.88	157,106	2,339,874	26,351	
Full Ht. Longt. Walls	1	8.00	1,399.00	26.083	24,327	120	2,919	0.360	47.00	700.00	13.46	137,205	2,043,473	39,288	
Hall Ht Longt Int	2	8.00	1,399.00	13.533	25,244	120	3,029	0.360	47.00	700.00	7.18	142,377	2,120,511	21,760	
Transv Interior top	9	8.00	38.333	11.080	2,548	120	306	0.036	47.00	700.00	20.54	14,373	214,064	6,281	
Transv Interior lower	9	8.00	89.800	14.333	7,723	120	927	0.110	47.00	700.00	7.83	43,557	648,715	7,259	
Upper Haunches	6	12.00	1,370.000	0.528	4,338	120	521	0.062	47.00	700.00	25.90	24,465	364,366	13,482	
Lower H - Lgt Int	6	12.00	1,396.000	0.333	2,791	120	335	0.040	47.00	700.00	2.47	15,741	234,434	826	
Lower H - Lgt 1/2 Int	4	12.00	1,396.000	0.222	1,240	120	148	0.018	47.00	700.00	1.87	6,996	104,193	278	
Lower H - Lgt Ext	2	12.00	1,370.000	0.444	1,217	120	146	0.017	47.00	700.00	1.87	6,861	102,191	273	
Lower H - Transv Int	18	12.00	91.300	0.666	1,095	120	131	0.016	47.00	700.00	2.47	6,173	91,938	324	
<b>END THICKENING</b>															
Top Slab	6	11.00	5.000	41.000	1,128	122	138	0.016	47.00	700.00	26.29	6,465	96,289	3,617	
Base Slab	6	26.00	5.000	94.000	6,110	122	745	0.089	47.00	700.00	1.75	35,035	521,794	1,304	
Exterior walls	12	16.00	5.000	21.660	1,733	122	211	0.025	47.00	700.00	13.00	9,936	147,981	2,748	
<b>ADDITIONAL CONCRETE</b>															
Concrete Columns	114	24.00	9.750	2.000	4,446	120	534	0.063	47.00	700.00	20.88	25,075	373,464	11,137	
Top Edge Curb	2	18.00	1,400.000	1.500	6,300	120	756	0.090	47.00	700.00	28.75	35,532	529,200	21,735	
Lower Edge Curb	2	30.00	1,400.000	0.667	4,666	120	560	0.066	47.00	700.00	17.25	26,317	391,961	9,659	

**WEIGHT AND CG - PONTOON**

ELEMENT	# UNITS	THICK (in)	LENGTH (ft)	WIDTH (ft)	VOLUME (ft <sup>3</sup> )	UNIT WT (pcf)	WEIGHT (kips)	INCR DRAFT (ft)	X (ft)	Y (ft)	Z (ft)	Wx (kip-ft)	Wy (kip-ft)	Wz (kip-ft)
<b>EQUIPMENT SUPPORTS</b>														
	0						0	0.000	47.00	20.00	28.00	0	0	0
	0						0	0.000	0.00	0.00	0.00	0	0	0
	0						0	0.000	64.00	56.00	36.50	0	0	0
	0						0	0.000	0.00	0.00	0.00	0	0	0
	0						0	0.000	0.00	0.00	0.00	0	0	0
	0						0	0.000	0.00	0.00	0.00	0	0	0
<b>MISC ATTACHMENTS AT FLOAT OUT</b>														
Towing BOLLARD & Padeyes	0						50	0.006	47.00	700.00	26.50	2,350	35,000	1,325
Bow Spoon	0						0	0.000	0.00	0.00	0.00	0	0	0
Skeg	0						0	0.000	0.00	0.00	0.00	0	0	0
	0						0	0.000	0.00	0.00	0.00	0	0	0
<b>PONTOON / FOUNDATION INTERFACE</b>														
Keel Thickening	0				0	120	0	0.000	0.00	0.00	0.00	0	0	0
Wall Thickening	0				0	120	0	0.000	0.00	0.00	0.00	0	0	0
					VOLUME (ft <sup>3</sup> )		WEIGHT (kips)		Xo (feet)	Yo (feet)	Zo (feet)	Wx (kip-ft)	Wy (kip-ft)	Wz (kip-ft)
BARE PONTOON SUBTOTAL					561,449		69642		47.00	700.00	14.08	3,273,187	48,749,600	980,546
BARE PONTOON CENTER OF GRAVITY														
<b>CONTINGENCIES</b>														
% Wt Inc-Conc Toler	10				54,763	125	6,845	0.813	47.00	700.00	14.08	321,733	4,791,762	96,381
Inc Top'g Toler top slab (in)	1	0.5	1400 000	90 000	5250	125	656	0.078	47.00	700.00	28.01	30,844	459,375	5,310
Inc Top'g Toler base slab (in)	1	0.25	1400 000	94 000	2742	125	343	0.041	47.00	700.00	0.69	16,107	239,896	236
Inc Top'g Toler intermediate sia (in)	1	0.25	1400 000	52 000	1517	125	190	0.023	47.00	700.00	16.01	8,910	132,708	3,035
					VOLUME (ft <sup>3</sup> )		WEIGHT (kips)		Xo (feet)	Yo (feet)	Zo (feet)	Wx (kip-ft)	Wy (kip-ft)	Wz (kip-ft)
BARE PONTOON + CONTINGENCIES - TOTALS					625,720		77,676		47.00	700.00	13.97	3,650,782	54,373,342	1,085,509
BARE PONTOON CENTER OF GRAVITY														

MISCELLANEOUS STRUCTURES & EQUIPMENT ALLOWANCE  
 \*\*\*\* BY OTHERS \*\*\*\*

WEIGHT AND CG - MISCELLANEOUS STRUCTURES AND EQUIPMENT										MISCELLANEOUS STRUCTURES & EQUIPMENT ALLOWANCE **** BY OTHERS ****				
ELEMENT	# UNITS	THICK (in)	LGTH (ft)	WIDTH (ft)	VOLUME (ft <sup>3</sup> )	UNIT WT (pcf)	WEIGHT (kips)	INCR DRAFT (ft)	X (ft)	Y (ft)	Z (ft)	Wx (kip-ft)	Wy (kip-ft)	Wz (kip-ft)
<b>EQUIPMENT - DRY WEIGHT</b>														
<b>SERVICES</b>							2,000	0.237	47.00	700.00	24.50	94,000	1,400,000	0
GROSS AMOUNT FOR SERVICES (ALLOWANCE)							0							0
<b>PRINCIPAL UTILITIES, MECHANICAL</b>							0							0
Hose cabinets and reels							0							0
Oil, waste/waste oil (OWWO)							0							0
Pipe and Hoses							0							0
Lift station/Oil Water separator							0							0
Valves and risers							0							0
Potable water (PW)							0							0
Pipe and Hoses							0							0
Sectionalizing valves							0							0
Back flow preventers							0							0
Hydrants							0							0
Metering							0							0
Sanitary Sewer (CH)							0							0
Pipe and Hoses							0							0
Sanitary lift station							0							0
Valves and risers							0							0
Steam (STM)							0							0
Pipe and Hoses							0							0
Valves							0							0
Expansion loops							0							0
Condensate return line							0							0
Compressed Air							0							0
Rigid pipes and flexible hoses							0							0
Valves and risers							0							0
J.P. - Aviation fuel							0							0
Rigid pipe and flexible hoses							0							0
Valves and risers							0							0
Diesel or light fuel (DFM)							0							0
Rigid pipe and flexible hoses							0							0
Valves and risers							0							0
<b>OTHER UTILITIES, MECHANICAL</b>							0							0
high pressure compressed air							0							0
Oxygen							0							0
Fire Protection							0							0
Salt water							0							0
Chilled Water							0							0
Pure Water							0							0
Feedwater							0							0
Ventilation							0							0
<b>PRINCIPAL UTILITIES, ELECTRICAL</b>							0							0
Shore power							0							0
Conduit and receptacle housing							0							0
Metering							0							0
Flexible cabling							0							0
Cable lockers/reels							0							0
Substation transformers							0							0
Industrial power							0							0
Conduit, lighting							0							0
Metering							0							0
Substation transformers							0							0
Ventilation							0							0
Switchgear							0							0

WEIGHT AND CG - MISCELLANEOUS STRUCTURES AND EQUIPMENT

ELEMENT	# UNITS	THICK (in)	LGTH (ft)	WIDTH (ft)	VOLUME (ft <sup>3</sup> )	UNIT WT (pd)	WEIGHT (kips)	INCR DRAFT (ft)	X (ft)	Y (ft)	Z (ft)	Wx (kip-ft)	Wy (kip-ft)	Wz (kip-ft)
Cable trays							0					0	0	0
Lighting fixtures							0					0	0	0
Communications							0					0	0	0
Utilities separation							0					0	0	0
Spill containment and control							0					0	0	0
<b>MISCELLANEOUS</b>														
Ramps							0					0	0	0
Bollards							0					0	0	0
Stairways							0					0	0	0
Fendering							0					0	0	0
Possible Int. deck Allowance	12	12.00	40.00	19.500	9.360	121	1,133	0.134	47.00	700.00	16.50	53,230	792,792	18,667
	0						0							
<b>EQUIPMENT SUBTOTAL</b>							<b>WEIGHT</b>		<b>Xo</b>	<b>Yo</b>	<b>Zo</b>	<b>Wx</b>	<b>Wy</b>	<b>Wz</b>
<b>EQUIPMENT CENTER OF GRAVITY</b>							3,133		47.00	700.00	21.61	147,230	2,192,792	67,667
								0.372						

**WEIGHT AND CG - MISCELLANEOUS STRUCTURES AND EQUIPMENT**

ELEMENT	# UNITS	THICK (in)	LGTH (ft)	WIDTH (ft)	VOLUME (ft <sup>3</sup> )	UNIT WT (pcf)	WEIGHT (kips)	INCR DRAFT (ft)	X (ft)	Y (ft)	Z (ft)	Wx (kip-ft)	Wy (kip-ft)	Wz (kip-ft)	
<b>EQUIPMENT - DRY WEIGHT - cont'd</b>															
CONTINGENCIES	20						627	0.074	47.00	700.00	21.61	29,446	438,558	13,537	
% Equipment Weight							WEIGHT (kips)		Xo (feet)	Yo (feet)	Zo (feet)	Wx (kip-ft)	Wy (kip-ft)	Wz (kip-ft)	
							3759	0.446	47.00	700.00	21.61	176,676	2,631,350	81,225	
<b>EQUIPMENT + CONTINGENCIES -- TOTALS</b>															
<b>EQUIPMENT CENTER OF GRAVITY</b>															
<b>BALLAST</b>															
Ballast - Cell 1	0				0	62.4	0	0.000	93.167	1399.167	0.667	0	0	0	
Ballast - Cell 2	0				0	62.4	0	0.000	93.167	1379.583	0.667	0	0	0	
Ballast - Cell 3	0				0	62.4	0	0.000	84.583	1399.167	0.667	0	0	0	
Ballast - Cell 4	0				0	62.4	0	0.000	9.417	1399.167	0.667	0	0	0	
Ballast - Cell 5	0				0	62.4	0	0.000	0.833	1399.167	0.667	0	0	0	
Ballast - Cell 6	0				0	62.4	0	0.000	93.167	0.833	0.667	0	0	0	
Ballast - Cell 7	0				0	62.4	0	0.000	0.833	0.833	0.667	0	0	0	
Ballast - Cell 8	0				0	62.4	0	0.000	0.833	0.833	0.667	0	0	0	
							WEIGHT (kips)		Xo (feet)	Yo (feet)	Zo (feet)	Wx (kip-ft)	Wy (kip-ft)	Wz (kip-ft)	
							0					0	0	0	
							VOLUME (ft <sup>3</sup> /gals)								
							0								
<b>BALLAST SUBTOTAL</b>															
<b>BALLAST CENTER OF GRAVITY</b>															
							0					0	0	0	
<b>MISCELLANEOUS STRUCTURES, EQUIPMENT AND BALLAST WEIGHT AND MOMENTS</b>															
<b>MISCELLANEOUS STRUCTURES, EQUIPMENT AND BALLAST CENTER OF GRAVITY</b>															
							3759	0.446	47.00	700.00	21.61	176,676	2,631,350	81,225	

NORTH


Plan - Pontoon Ballast Cells

**PONTOON - DELIVERY VOYAGE - TRANSPORT 2**

TOTAL WEIGHT AND CENTER OF GRAVITY							
Weights and Moments (pg 2 & pg 4)							
Center of Gravity							
WEIGHT (kips)	DRAFT (ft)	Xo (feet)	Yo (feet)	Zo (feet)	Wx (kip-ft)	Wy (kip-ft)	Wz (kip-ft)
81.435	9.668	47.00	700.00	14.33	3,827.458	57,004.692	1,166,733

**HYDROSTATIC PROPERTIES**

Pontoon Weight = 77,676 kips      Ave. Draft due to Pontoon Wt = 9.22 ft      Displacement = 1,213,691 cu ft  
 Misc Structures and Equipment Weight = 3,759 kips      Ave. Draft from Misc St. & Equ Wt = 0.45 ft      Displacement = 58,736 cu ft  
 Ballast = 0 kips      Ave. Draft due to Ballast = 0.00 ft      Displacement = 0 cu ft  
**Total Weight = 81,435 kips      Average Total Draft = 9.67 ft      Displacement = 1,272,426 cu ft**

Load To Sink Pontoon 1" = 701.87 kips per inch

Freeboard at Delivery Voyage = 18.33 ft

**METACENTRIC HEIGHT CALCULATION - UNBALLASTED**

**X-AXIS (Weak Dir)**  
 KB = 4.83 ft (Center of Buoyancy to Keel)  
 BM = 76.15 ft (Center of Buoyancy to Metacenter)  
 KM = 80.99 ft (Keel to Metacenter)  
 KG = 14.33 ft (Keel to Center of Gravity)  
 GM = 66.66 ft (METACENTRIC HEIGHT)

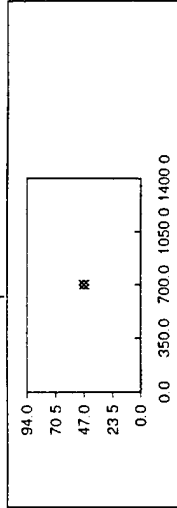
**Y-AXIS (Strong Dir)**  
 KB = 4.83 ft (Center of Buoyancy to Keel)  
 BM = 16892.66 ft (Center of Buoyancy to Metacenter)  
 KM = 16897.50 ft (Keel to Metacenter)  
 KG = 14.33 ft (Keel to Center of Gravity)  
 GM = 16883.17 ft (METACENTRIC HEIGHT)

Moment to Heel 1" = 4,813 kip-ft

Moment to Trim 1" = 81,838 kip-ft

Mx = (0) kip-ft  
 Trim X = 0.00 in  
 Theta X = 0.00 degrees

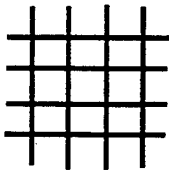
My = (0) kip-ft  
 Trim Y = 0.00 in  
 Theta Y = 0.00 degrees



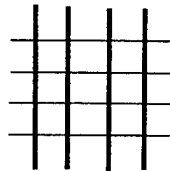
## CARBON GRIDS/MESH — QUANTITIES

As part of Phase 1, an estimate of the quantity of CFRP mesh that would be used in the construction of the floating pier was prepared. This information was then used to estimate the cost associated with using CFRP to reinforce concrete. The steps involved in this estimation were

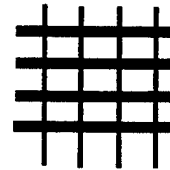
- To establish the structural system of the pier
  - To analyze key elements for stress and strain under service and ultimate loads
  - To relate these stresses to cross-sectional areas of mesh required
  - To determine quantities of mesh based on assumed mesh configurations
  - To assume a unit cost for CFRP mesh and determine a cost accordingly
1. The structural system consists of precast wall elements with precast top and intermediate deck slabs. The deck slabs also act as stay-in-place forms for the cast-in-place topping. The keel slab is cast-in-place, as are the infill sections between precast sections.
  2. Three key elements were analyzed using a stress block analysis, as discussed in Section 8.0, Design Approach. These elements were the keel slab, the top deck slab, and the center longitudinal wall. Each element was analyzed in two locations, one at the location of maximum positive moment, and one at the location of maximum negative moment. Both service and ultimate load levels were examined. The maximum allowable stress level in the fibers was set at 50 percent of the ultimate stress in order to avoid the possibility of creep rupture. The area of nonprestressed fiber required for each section was determined.
  3. For sections that were not analyzed, the cross-sectional area of fiber required was estimated. Based on the fiber amounts required for the key elements, cross-sectional areas of fiber required for the remaining elements were calculated using conservative assumptions for forces developed in the elements.
  4. Four types of mesh were used in the analysis. The first of these, Type 0, was a sample mesh provided by Torayca, and was 12K  $\times$  12K tow, with a grid spacing of 20 mm. The properties of this mesh, specifically weight per plan area and density, were known. In order to reduce the number of types of meshes that would need to be placed, three new mesh types were developed. For all three meshes, the grid spacing was set at 25 mm, and the properties were calculated from those given for the Type 0 mesh. The configurations of the new meshes are shown below.



Type 1 - 48K  $\times$  48K Tow



Type 2 - 12K  $\times$  48K Tow



Type 3 - 48K  $\times$  160K Tow

5. The area required for each element was discretized into multiples of the above meshes. No more than three layers of mesh were allowed on any face of an element. From this, the total plan areas and weight of each mesh type was found. An allowance for splicing was included.

The table below shows the estimated amounts of fiber required. It must be noted that the values of mesh quantities are preliminary and based on an initial analysis of parts of the structure. The estimated total weight of carbon fiber is 66 tons.

Type of Mesh	Total Plan Area (sq ft)	Total Weight (long tons)
Type 1	1,570,000	40.0
Type 2	1,050,000	16.5
Type 3	176,000	9.5





## APPENDIX E MOORING LOAD CALCULATIONS

### Preliminary Estimates of Mooring Pile Strength and Prestressing Requirements

#### LOADING CONDITIONS

##### Assumptions

Two applicable load conditions – wind and current. Assume both loads are broadside to the ship. Maximum current and wind occur simultaneously. Wind area is calculated based on light ship area and current forces are calculated based on LOA x the maximum draft. In addition, assume that the wind load for the ships in the leeward berth is 50 percent of the wind load on the windward vessels.

##### Wind Load

$$F_{yw} = \frac{1}{2} \rho_a \cdot V_w^2 \cdot A_y \cdot C_{yw} \cdot f_{yw}(\theta_w) = 2300 \text{ kips}$$

$$\begin{aligned} \rho_a &= 0.00237 \text{ slugs/ft}^3 \\ V_w &= 80 \text{ mph} = 117.3 \text{ fps} \\ A_y &= 45,500 \text{ ft}^2 / \text{per ship} \times 2 \text{ ships} + 0.50 \times 45,500 \text{ ft}^2 / \text{per ship} \times 2 \text{ ships} = 136,500 \text{ ft}^2 \\ C_{yw} &= 1.0 \text{ (conservative)} \\ f_{yw}(\theta_w) &= 1.0 \text{ (broadside wind)} \end{aligned}$$

##### Current Load

$$F_{yc} = \frac{1}{2} \rho_w \cdot V_c^2 \cdot L_{wL} \cdot T \cdot C_{yc} \cdot \sin\theta_c = 1400 \text{ kips}$$

$$\begin{aligned} \rho_w &= 2.0 \text{ slugs/ft}^3 \\ V_c &= 3.4 \text{ fps} \\ L_{wL} &= \text{LOA} = 600 \text{ ft} / \text{per ship} \times 2 \text{ ships} \\ T &= 33 \text{ ft} \\ C_{yc} &= 3.0 \text{ (assumed average value)} \\ \sin\theta_c &= 1.0 \text{ (broadside wind)} \end{aligned}$$

The sum of these two components gives the maximum lateral mooring load. Therefore, total load on system is 3700 kips. Assume that the load is uniformly distributed along the length of the pier – 2.54 kips/ft.

## PRESTRESS REQUIREMENT

Assume that the floating pier is supported by two pile clusters at its ends. Therefore, the pier acts like a simple beam under wind and current loads.

$$M = wl^2/8 = 622,300 \text{ kip-ft}$$

$$\begin{aligned} w &= 2.54 \text{ kip/ft} \\ l &= 1400 \text{ ft} \end{aligned}$$

Find stress in pier.

Assume external and keel plates are 12 inches thick, internal bulkheads are 8 inches thick, and upper and lower decks are 18 and 12 inches thick, respectively.

$$\sigma = Mc/I = 760 \text{ psi}$$

$$\begin{aligned} M &= 622,300 \text{ kip-ft} = 7,467,600,000 \text{ lb-in} \\ c &= 47 \text{ ft} = 564 \text{ inches} \\ I &= \end{aligned}$$

$$\begin{aligned} \sum I_o + \sum A r^2 &= \frac{30 \text{ in} \cdot (94 \text{ ft})^3}{12} + 2 \cdot \frac{(14.5 \text{ ft}) \cdot (8 \text{ in})^3}{12} + 2 \cdot (14.5 \text{ ft}) \cdot 8 \text{ in} \cdot (40 \text{ ft})^2 + 2 \cdot \frac{(14.5 \text{ ft}) \cdot (12 \text{ in})^3}{12} + 2 \cdot (14.5 \text{ ft}) \cdot 12 \text{ in} \cdot (40 \text{ ft})^2 \\ &= 5.558 \times 10^9 \text{ in}^4 \end{aligned}$$

Thus, an approximately 760 psi prestress should be applied to the concrete hull in order to eliminate tension in concrete.

## SIZING MOORING PILES

The floating pier is supported by two pile clusters at its ends. Each pile cluster consists of six 6-foot-diameter concrete filled composite piles with a concrete cap.

### Assumptions

- The pile shell (fiber glass reinforced plastic shell) carries all of tensile stresses, thus ignoring tensile stress in concrete
- GFRP strength and the assumption of linear stress distribution are based upon the test data and supplemental calculations published by Lehigh University and Rutgers University (Reference: "Technical Reference: Precast Composite Containment Pile" by Lancaster Composite Inc.)

The mooring pile section and material properties are calculated with MATHCAD program as follows.

### GFRP Pile Shell

Outside diameter	72.00 in <sup>2</sup>
Inside diameter	66.00 in <sup>2</sup>
Wall thickness	3.00 in
Ultimate Tensile Strength	70.0 ksi
Ultimate Compressive Strength	40.0 ksi
Modulus of Elasticity, $E_s$	3,000.0 ksi

## Concrete Core

Ultimate Concrete Strength at 28 days,  $f_c' = 6,500$  psi

### Determine the Transformed Section Properties

$$\text{Concrete Modulus of Elasticity, } E_c = 57000\sqrt{f_c'} = 4596000 \text{ psi.}$$

$$\text{GFRP Modulus of Elasticity, } E_s = 300000 \text{ psi.}$$

$$\text{Modulus Ratio, } n = E_c / E_s \quad n = 1.5$$

Shell wall thickness  $t = 2.5$  inches

$$D = 72", d = D - 2t = 67"$$

$$\text{Transformed width as a function of } y \text{ to pile center: } L(y) = 2n\sqrt{\left(\frac{d}{2}\right)^2 - y^2}$$

$$\text{Area of GFRP shell, } A_s = \frac{\pi(D^2 - d^2)}{4} = 545.9 \text{ in.}^2$$

$$\text{Moment Inertial of Shell } I_s = \frac{\pi(D^4 - d^4)}{64} = 330000 \text{ in.}^4$$

Initial guess of distance from center of pile to neutral axis  $y_a = d/4$

$$Y_a(c) = \frac{\int_c^{d/2} y L(y) dy}{A_s + \int_c^{d/2} L(y) dy}$$

Distance from center of pile to neutral axis  $h$  can be calculated by iteration:

$$h = \text{root}(Y_a(y_a) - y_a, y_a)$$

By iteration,  $h = 15.41$  in.

$$\text{Area of Concrete Core (compression zone only) } A_c = \int_h^{d/2} L(y) dy = 1131 \text{ in.}^2$$

$$\text{Distance from pile center to centroid of concrete compression zone } y_c = \frac{\int_h^{d/2} y L(y) dy}{A_c} = 22.84 \text{ in}$$

$$\text{Moment Inertial of Concrete } I_c = \int_{y_c - d/2}^{y_c - d} y^2 L(y_c - y) dy = 25,675 \text{ in.}^4$$

Moment Inertial of Composite Section (transformed to equivalent GFRP section)

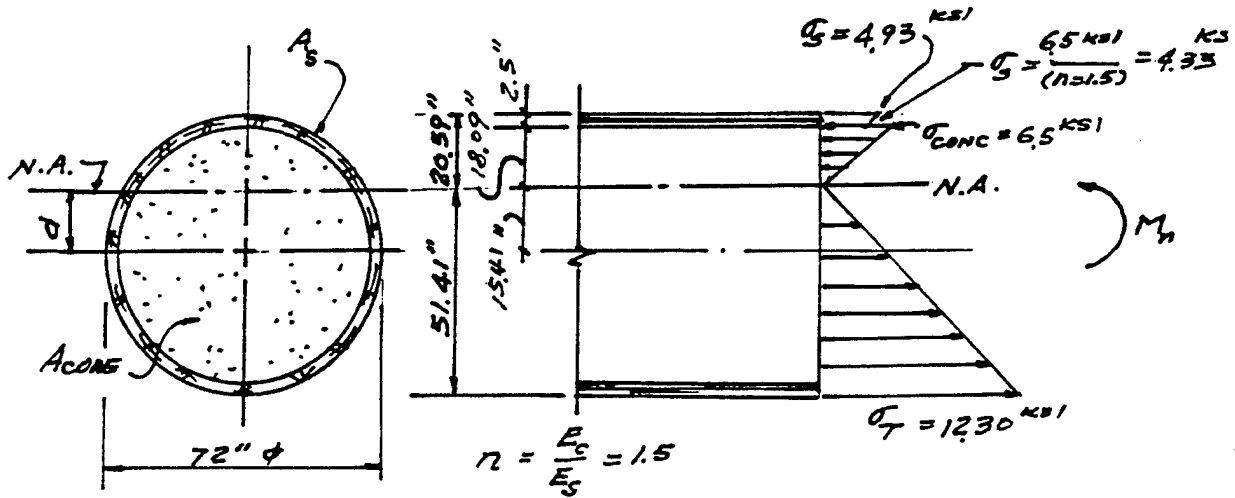
$$I_{\text{transform}} = I_c + I_s + A_c(y_c - Y_a(h))^2 + A_s Y_a(h)^2 = 547744 \text{ in.}^4$$

$$\text{Compressive Sectional Modulus } S_c = \frac{I}{D/2 - h} = 26,598 \text{ in.}^3$$

$$\text{Tensile Sectional Modulus } S_t = \frac{I}{D/2 + h} = 10,655 \text{ in.}^3$$

**Calculate the flexural capacity of a mooring pile**

The Stress Diagram for the composite pile section at a concrete stress  $f_c' = 6.5$  ksi is calculated and as shown below.



**STRESS DIAGRAM**

From the stress diagram, the maximum moment capacity for the section can be determined below.

Maximum compressive stress in the extreme fiber of GFRP shell is equal to 4.93 ksi

$$M^*y/I_{transform} = 4.93 \text{ ksi,}$$

Where:  $y = 20.59$  inches and  $I_{transform} = 547,744 \text{ in}^4$

I.e.  $M_{cap} = 4.93 * I_{transform}/y = 4.93 * 547,744 / 20.59 = 131,150 \text{ kip-in} = 10,929 \text{ kip-ft}$

**Determine numbers of 6-foot composite pile required to resist the total wind/current load.**

Based upon MIL-HDBK-1025/1, load factor for wind plus wave load is 1.25.

Assume that pile clusters at each end of the floating pier takes an equal amount of the factored design wind/current load, then the force on each end.

$$H = 1.25 \times 3,700 \text{ kips} / (2 \text{ ends}) = 2,312.5 \text{ kips/end}$$

Assume that the total length of the mooring piles with a rigid pile cap equals the freestanding length in water ( $40' - 13' = 27'$ ) plus the distance to an assumed point of fixity (4 times pile diameter = 24 feet) below sea floor.

$$L = 27' + 24' = 51'$$

The total required design bending moment with an inflection point at the midlength of the pile could be calculated as

$$M_{\text{Demand}} = PL/2 = 2312.5 \text{ kips} \times 51 \text{ ft} / 2 = 58,969 \text{ kip-ft}$$

The total numbers of piles that required at each end of the floating pier is

$$N_o = M_{\text{Demand}} / M_{\text{Cap}} = 58,969 \text{ kip-ft} / 10,929 \text{ kip-ft} = 5.4$$

Use six 6-foot-diameter pile clusters at each end

Back-check the design capacity.

The factored design wind/current load at each of the 6-foot-diameter mooring pile.

$$H_1 = 1.25 \times 3,700 \text{ kips} / (6 \times 2 \text{ ends}) = 385.42 \text{ kips}$$

The design bending moment required at each of the 6-foot pile.

$$M_1 = H_1 \times L/2 = 385.42 \text{ kips} \times 51 \text{ ft} / 2 = 9,828 \text{ kip-ft} < M_u = \phi M_{\text{cap}} = 0.9 \times 10,926 \text{ kip-ft} = 9,833 \text{ kip-ft, ok}$$

#### Check Pile Top Deflection

The cracked section for a composite pile.

$$EI_{\text{transform}} = 3000 \text{ ksi} \times 547744 \text{ in}^4 = 1,643,232,000 \text{ kip-in}^2$$

Unfactored lateral load on top of each pile = 385.4 kips / 1.25 = 308.3 kips

$$\Delta_{\text{cr}} = H_1 \times L^3 / (12 \times EI_{\text{transform}}) = 308.3 \text{ kips} \times (51 \times 12)^3 / (12 \times 1,643,232,000) = 3.6 \text{ inches}$$

(approximately 0.6% of unsupported pile length)

## APPENDIX F

### Preliminary Listing Modular Hybrid Pier Pier Hardware and Ancillary Applications that Could Take Advantage of FRP Composite Materials 13 December 1998

(Revised after 17 December 1998 Meeting and Composites Institute Input of 24 March 1999)

Context: In the contacts the Composites Institute made with suppliers, it was requested that they stress that we are looking for products that have a very high probability of providing good durability over a 70- to 100-year life span in outside marine exposure. We indicated that we would appreciate comments from suppliers regarding things that would need to be done to reach this life span requirement if their product does not already have this level of durability.

Discussion approach used in the 17 December 1998 meeting.

- Discuss requirement as it relates to FRP concrete pier.
- Has something exactly like this already been developed?
- Has something similar to this been developed?
- Would development of this be simple or difficult?
- Is it likely that required quality/reliability can be achieved?
- Is quantity required for prototype sufficient to encourage development?
- Is using FRP for this application a good idea?
- Is there an FRP element like this currently in service? (Where/How long?)

1. **Longitudinal global prestressing system CFRP Tendons (450 feet long)**

- Already developed                      □ Development required

*Comment: Tendons are shipped on spools with 92-inch flanges. A full spool can hold up to 10,000 feet of tendon material depending on the size of the tendon. There is essentially no length limitation on tendons. Testing will be required to confirm material properties. United States suppliers include Glasforms and DFI. Japanese suppliers include Leadline - Mitsubishi Chemical and Tokyo Rope. Japanese have a full post-tensioning system that has been on the market for approximately seven years. Carbon fiber tendons have been used extensively in Japan for nearly 15 years.*

*More than 50 technical papers have been presented in a variety of technical venues that indicate no long-term performance problems with carbon fiber tendons to date. Extrapolation of stress-strain curves and loss-of-tension curves suggest that carbon fiber tendons should provide long-term performance in the modular hybrid pier to satisfy the Navy's engineering design requirements. However, continued testing is required, particularly in some form of accelerated aging tests to better establish the long-term basis for the design.*

*The new generation of low-cost carbon fibers expected to be commercialized within the next two to five years could significantly impact the current cost premiums associated with carbon fiber tendons. However, engineers should be cautioned that these low-cost carbon fiber materials will absolutely not be of the same quality as traditional carbon fiber materials used for aerospace applications and that these new carbon fiber materials cannot be expected to have the same long-term durability performance as their high-cost aerospace predecessors. Such new materials must be subjected to a full regimen of extensive long-term durability testing before any basis for predicting their performance can be established.*

Europeans seemed to have stopped developing CFRP prestressing systems in favor of glass fiber systems. Dr. Urs Meier at the Swiss Federal Laboratories, a long-time proponent of composite prestressing, has been successfully experimenting with glass fiber tendons operating at lower levels of stress (<30 percent of short-term ultimate). His latest publications indicate that glass fiber tendons at these lower stress levels perform as well as carbon fiber tendons, but at significantly lower cost.

Prestressing Tendon Ducts             Already developed    Development required

Comment: Use PVC or other type of corrugated plastic pipe for tendon ducts. Don't use FRP materials for this. There is no reason to use FRP composite materials in a nonstructural application, such as tendon sheaths.

Prestressing Anchors                 Already developed    Development required

Comment: Anchors will need to be developed for flat strip tendons. Commercial anchoring systems already exist for the Japanese products.

Anchor Confinement                 Already developed    Development required

Anchor confinement already exists through the work between DYWIDAG and South Dakota School of Mines & Technology. Marshall Industries could also likely make the confinement reinforcing. They are now 51 percent owned by Reichold Chemical. They make glass, carbon, and hybrid reinforcing bars in #4 and #6 sizes.

Tendon Grout                         Already developed    Development required

Comment: Normal grout used for steel tendon grouting should work for carbon tendons.

## 2. Transverse global prestressing CFRP (100 feet long)

Tendons                                 Already developed    Development required

Comment: See comments to No. 1 above.

Tendon Ducts                         Already developed    Development required  
Anchors                                 Already developed    Development required

Comment: See comments to No. 1 above.

Anchor Confinement                 Already developed    Development required  
Tendon Grout                         Already developed    Development required

Comment See comments to No. 1 above.

## 3. Prestressing of deck planks CFRP (25 feet long)

For Pretensioning                 Already developed    Development required

Comment: For this shorter length of prestressing material, it may be desirable to use tendons with deformed surfaces. The process of deforming the surface to increase bond adds about 25 percent to the cost of a tendon. Prototypical methods have been developed for pretensioning. Further attention to methods of gripping strand for tensioning (equivalent of strand vice) is warranted for production scale work.



4. Mesh reinforcing in walls, keel, and deck elements

CF Orthogonal 2-D Grid                     Already developed    Development required  
CF Orthogonal 3-D Grid                    Already developed    Development required

Comment: NEFMAC, a 10-year-old Japanese 2-D carbon fiber grid reinforcement is being produced under license in Canada. Dr. Sami Rizkalla of the University of Manitoba is an acknowledged leader in this field. Toray is also making 2-D carbon fiber grids in Japan and will soon have the capability of making them in the United States. Clark Schwebel Tech Fab produces a 2-D mesh with glass fibers, but carbon or aramid fibers could be used as well. BTI makes advanced fiber architectural reinforcements. Hexcel Civil Structures, Fyfe Systems, Xxyss, Inc., Master Builders ("M-Brace"), and Hardcore also produce surface or external 2-D reinforcing system.

GF Orthogonal 2-D Grid                    Already developed    Development required  
GF Orthogonal 3-D Grid                    Already developed    Development required

Comment: Dr. Larry Bank (University of Wisconsin-Madison) has successfully demonstrated reinforcement of structural concrete using 3-D glass fiber materials. Variations of fiberglass/vinyl ester grating have also been used for the past 25 years as 3-D reinforcement in concrete without problems.

Clark Schwebel and others (BTI, Hexcel Civil Structures, Fyfe Systems, Hardcore, and others) are making a resin impregnated mesh from glass.

5. Bar reinforcing CFRP

Straight     Already developed    Development required  
In specific geometries                        Already developed    Development required

Comment: No one in the United States produces a carbon fiber reinforcing bar due to cost. The technical capability exists, but there is no market demand for rebar that is 15 to 20 times more expensive than fusion-bonded epoxy coated steel. The product has a 100 percent probability of successful development if a commercial market could be identified.

The use of GFRP rebars is approximately 20 years old. First generation products included external wraps of reinforcement to achieve surface deformations and were used primarily in nonmagnetic construction associated with hospital magnetic resonance imaging (MRI) units. ACI Committee 440 has just balloted the design standard for FRP composite rebar.

6. Shear reinforcement for concrete elements

GFRP      Already developed                     Development required  
CFRP      Already developed                     Development required

Comment: Marshall Industries, Glasforms, Huges Brothers, and International Grating all make commercial GFRP reinforcing bars for concrete. Marshall Industries can also make CFRP rebars. Glasforms produces pultruded rods that are fabricated into tendons for prestressing and post-tensioning. Use of bent CFRP for stirrups in concrete design may not be the most economical way to reinforce for shear. Marshall Industries makes bent glass reinforcement and is developing a carbon fiber version of this reinforcement.

7. Confinement reinforcement for concrete elements

GFRP      Already developed    Development required

Comment: Lancaster, Hardcore, Fibercast, A.O. Smith, TPI, and others have developed confinement shells of various types for piling. Most of this material is glass; some may have developed carbon jackets.

Exterior confinement using glass fibers and iso polyester, vinyl ester or epoxy resins has been an established technology in the industrial chemical processing industry (CPI) for more than 35 years. Columns, posts, tanks, and related structures have been successfully confined with GFRP. A 25-foot- high GFRP/vinyl ester-concrete filled column has been in service at BASF/Wyandotte in Giesmer, Louisiana, for more than 20 years with no measurable deterioration. The recent Caltrans performance specification for structural column wrapping, which is a performance specification, actually favors glass fibers based on cost and performance. This application is 100 percent developed.

Hexel Civil Structures, Fyfe Systems, Xxyss, Inc., and others have surface applied composite exterior confinement products.

Lancaster Composite and Hardcore have commercial bearing pile and fender pile systems based on FRP composite exterior confinement shells that are filled with structural concrete. TPI has produced such a system, but is not now commercially active in the market. Fibercast, A.O. Smith, and others produce filament-wound FRP pipe that can be used as exterior confinement.

CFRP

Already developed??

Development required

Comment: Carbon fiber jackets could be easily developed, but carry such a premium of cost that there is little commercial demand for such products.

#### 8. Low-pressure utility piping

Piping runs

Already developed

Development required

Comment: This technology is 100 percent commercially developed.

Connections

Already developed

Development required

Comment: This technology is 100 percent commercially developed.

Valves

Already developed

Development required

Comment: GFRP piping of all sizes is in common use by industry in applications up to 450 degrees F and 350 psi. It is commonly used for corrosives. Supplied by A.O. Smith, Fibercast, and Ameron.

#### 9. Drains and sump housings

Already developed

Development required

Comment: Drains and sumps have been produced in GFRP since the 1950s. The majority of drains and sumps in the wastewater industry are already composites; 100 percent commercially developed.

Grating

Already developed

Development required

Comment: 100 percent commercially developed. There are 23 companies that make this type of product out of GFRP. They have standard products and can cost effectively make minor modifications to their standard products. These gratings have been in service for more than 40 years. There is no reason to do anything other than to accept this application as fully developed and suitable for this application. The Composites Institute's Fiber Glass Grating Manufacturer's Council is finalizing a new industry design and performance standard for composite gratings. Fire retardant gratings are also available to meet the demands of the offshore oil & gas industry.

**10. Miscellaneous embedments**

Ladder Attachments                     Already developed    Development required

*Comment: 100 percent commercially developed. FRP composite ladders are already the standard of the electrical and chemical processing industries. Approximately 80 percent of the ladder market is composites. Werner, the largest United States ladder manufacturer produces more than 75 percent of its ladders in composites vs. wood or aluminum.*

Construction Support Elements     Already developed    Development required  
Structural Anchors                     Already developed    Development required

*Comment: Discussion suggested not to use typically available composite anchor bolts. Typical threading cuts composite fibers. Use stainless steel anchor bolts or embedments other than threaded FRP composite bolts.*

**11. Hatch covers, opening covers**

Already developed    Development required

*Comment: 100 percent commercially developed. These can be designed to accommodate high-concentrated loads. Nearly 100 percent of the commercial barge covers on the Mississippi and Ohio Rivers are FRP composites, produced by Xerxes and others.*

**12. Interior structure**

Interior Mezzanine Floors            Already developed    Development required

*Comment: 100% commercially developed. FRP composite flooring is a standard application in the food processing, chemical, and sanitary industries. In addition, a number of companies produce wear-resistant flooring for warehouse and high traffic intensity areas.*

Racks and shelving                     Already developed    Development required

*Comment: Meeting participants were not aware of FRP systems that are cost-effective for racks and the like. Of course, there are a full range of GFRP structural shapes that mimic steel structural shapes. These could be used.*

**13. Ladders/stairs and manways**

Already developed    Development required

*Comment: See comments on ladders above, No. 10.*

Handrails                                 Already developed    Development required

*Comment: 100 percent commercially developed. These are in common use. There are no handrail applications in the proposed pier design that could not be easily accommodated by FRP composites with a 45-year performance history in the chemical processing, marine, offshore, and related industries.*

**14. Utility supports and cable trays**

Already developed    Development required

Comment: 100 percent commercially developed. Virtually all of the cable and bus tray products used in the chemical processing industry are FRP composites. In addition, all of the cable trays in the "Chunnel" between England and France are a glass fiber/acrylic resin product, chosen for both corrosion and fire-resistant characteristics.

Support embeddings  Already developed  Development required

Comment: These are in common use. See earlier comment on anchor embeddings.

**15. Lighting standards**

Already developed  Development required

Comment: 100 percent commercially developed. Shakespeare makes FRP lighting masts up to 45 or 50 feet in length. Creative Pultrusions also produces commercial lighting standards. In Europe, lighting poles up to 100 feet in length are produced. The FRP light poles have more than 30 years of performance history with no problems of UV or other deterioration, as UV coatings are available.

**16. Lighting fixtures**

Already developed  Development required

Comment: Participants suggested use of extruded plastic. There would be no reason to use composites for such a nonstructural application.

**17. Electrical conduit**

Already developed  Development required

Comment: 100 percent commercially developed. Participants suggested using unreinforced plastic conduit for this. The chemical processing, offshore oil, and gas industries use FRP composite conduit where structural performance is required.

**18. Electrical junction boxes**

Already developed  Development required

Comment: 100 percent commercially developed. Nearly 100 percent of the electrical enclosures and equipment housings in the corrosion resistant equipment industry are composites. The earliest products date from the mid-1950s and are still in service. Unreinforced plastic may be best for smaller electrical junction boxes.

**19. Fender system elements**

Attachments for floating pier	<input checked="" type="checkbox"/> Already developed <input type="checkbox"/> Development required
Load distribution elements	<input checked="" type="checkbox"/> Already developed <input type="checkbox"/> Development required
Energy absorbing elements	<input checked="" type="checkbox"/> Already developed <input type="checkbox"/> Development required

See previous comments about composite anchors, No. 10 above.

Comment: NFESC has a fender program concentrating on this now. Information on preferred composite fender systems will be provided to the design team by NFESC.

20. Access ramp structure (pier to shore)

Already developed  Development required

Comment: *An AASHTO HS-25 rated FRP composite bridge or bridge deck is commercially available from Creative Pultrusions, Kansas Structural Systems, Martin-Marietta, Hardcore, and Mesa Fiber Glass. Other companies are designing new versions of these bridges and bridge decks.*

21. Floating pier mooring provisions

Line Moorings  Already developed  Development required

Housings and Guides  Already developed  Development required

Line anchor provisions  Already developed  Development required

Sea floor anchors and  
line connections  Already developed  Development required

Comment: *Participants felt that for things that require abrasion resistance, like mooring line housings and guides, stainless steel is likely a better material.*

Guide pile moorings  
Caisson elements  Already developed  Development required

Comment: *Consider application of Lancaster (or similar) pile concept.*

Interface guide pile elements  
(ductile piling element)  Already developed  Development required

Comment: *These elements may have abrasion requirements that could benefit from some type of abrasion resistant liner.*

22. Vessel mooring provisions

Bollards  Already developed  Development required

Fairleads  Already developed  Development required

Comment: *These elements are likely best suited to current cast steel material. Don't try to convert to FRP construction.*

23. Personnel brows

Already developed  Development required

Comment: *Consider potential for a fold-away brow. FRP personnel bridges up to 120-foot span have been built. The electrical utility industry routinely uses FRP composite buckets and booms that could be adapted to this service.*

24. Signs

Already developed  Development required

Comment: *100 percent commercially developed. FRP signs have been in use in the highway industry since the mid-1970s. Applications include both overhead (large) signs, as well as small post-mounted signs, and FRP composite breakaway highway sign posts. Nearly two dozen fabricators, including Kalwall, Resolite, American Acrylic, and others, make FRP composite sign blanks.*

**25. Transformer vaults**

■ Already developed  Development required

*Comment: 100 percent commercially developed. More than a dozen composites fabricators produce transformer vaults and transformer pads. The Electric Power Research Institute (EPRI) has developed and licensed a transformer vault design for pole-top-mounted and pad-mounted electrical transformers.*

**26. Stay-in-place forms**

■ Already developed  Development required

*Comment: Consider the possibility of prestressed stay-in-place forms.*

**27. Reusable form work**

■ Already developed  Development required

*Comment: 100 percent commercially developed. Reusable composite concrete pouring forms have been in general use in the construction industry since the mid-1950s. MFG of Ashtabula, Ohio, is an industry lead in this field. They produce hundreds of different styles of pan-type pouring forms and panel forms that outlast steel 10-to-1 and give much better dimensional control and are lightweight.*

## GENERAL OPINION COMMENTS ON STRUCTURAL COMPOSITES

by the Composites Institute

Various university researchers, as well as some researchers at various Federal laboratories, appear to overemphasize the importance of the fiber phase of the composite (i.e., material and fiber architecture) while underemphasizing the role and importance of the resin phase of the composite.

This can lead to technically inaccurate, sweeping generalizations about the suitability of a given composite material for a specific application. For example, many researchers accept as an article of faith that glass fiber reinforced composites cannot provide long-term performance in the alkali environment of cement. In fact, glass fiber reinforced composites have been proven to work well in many alkali applications.

Recently, in conjunction with the Ohio Department of Transportation and the Civil Engineering Highway Innovative Technology Evaluation Center (HITEC), the Composites Institute's Market Development Alliance exhumed and analyzed glass fiber/vinyl ester dowel bars that had been in demanding service in Interstate 77 for 15 years. The analysis, perhaps the most thorough in the industry's history, found no evidence of any deterioration or loss of properties (tensile, flexural modulus, hardness, surface condition, etc.) after 15 years in service. Of particular interest to researchers was the fact that the cut ends of these 1.5-inch-diameter FRP dowel bars were not sealed prior to installation. There were no effects on the glass fiber reinforcement even in the exposed ends.

If glass fiber deterioration of a properly constructed FRP composite laminate were the problem that some researchers have attempted to portray, the in-service failures of composites over the last 50 years would have been profound. In fact, however, no evidence exists to back up such sweeping claims of nonperformance. If the resin is suitable for the application, it protects the fibers. If the resin is not, no fiber of any type will survive to provide the intended long-term design performance.

### COMMENT BY NFESC

Regarding 15-year tests on GFRP dowels by the Composites Institute, it is believed that the GFRP dowels indicated were not subjected to sizable loads. In airfield pavements, the U.S. Navy routinely gets equally as good Falling Weight Deflectometer joint efficiencies without any dowels, which indicates that the subgrade carries most of the load. Buried GFRP tanks also have lasted for decades, but the design stress levels were usually 10 percent of the ultimate short-term strength. Glass fibers are much more susceptible to corrosion under tension, in addition to creep rupture. ACI 440F limits GFRP allowable stresses to 13 percent of ultimate. Hence, the durability of GFRP will not be a problem, as long as the allowable loads remain below 10 percent or so of ultimate.