



The Influence of Honing on the Wear of Ceramic Coated Piston Rings and Cylinder Liners

Kevin Radil

U.S. Army Research Laboratory, Glenn Research Center, Cleveland, Ohio

DISTRIBUTION STATEMENT A
Approved for Public Release
Distribution Unlimited

20000309 046

The NASA STI Program Office . . . in Profile

Since its founding, NASA has been dedicated to the advancement of aeronautics and space science. The NASA Scientific and Technical Information (STI) Program Office plays a key part in helping NASA maintain this important role.

The NASA STI Program Office is operated by Langley Research Center, the Lead Center for NASA's scientific and technical information. The NASA STI Program Office provides access to the NASA STI Database, the largest collection of aeronautical and space science STI in the world. The Program Office is also NASA's institutional mechanism for disseminating the results of its research and development activities. These results are published by NASA in the NASA STI Report Series, which includes the following report types:

- **TECHNICAL PUBLICATION.** Reports of completed research or a major significant phase of research that present the results of NASA programs and include extensive data or theoretical analysis. Includes compilations of significant scientific and technical data and information deemed to be of continuing reference value. NASA's counterpart of peer-reviewed formal professional papers but has less stringent limitations on manuscript length and extent of graphic presentations.
- **TECHNICAL MEMORANDUM.** Scientific and technical findings that are preliminary or of specialized interest, e.g., quick release reports, working papers, and bibliographies that contain minimal annotation. Does not contain extensive analysis.
- **CONTRACTOR REPORT.** Scientific and technical findings by NASA-sponsored contractors and grantees.

- **CONFERENCE PUBLICATION.** Collected papers from scientific and technical conferences, symposia, seminars, or other meetings sponsored or cosponsored by NASA.
- **SPECIAL PUBLICATION.** Scientific, technical, or historical information from NASA programs, projects, and missions, often concerned with subjects having substantial public interest.
- **TECHNICAL TRANSLATION.** English-language translations of foreign scientific and technical material pertinent to NASA's mission.

Specialized services that complement the STI Program Office's diverse offerings include creating custom thesauri, building customized data bases, organizing and publishing research results . . . even providing videos.

For more information about the NASA STI Program Office, see the following:

- Access the NASA STI Program Home Page at <http://www.sti.nasa.gov>
- E-mail your question via the Internet to help@sti.nasa.gov
- Fax your question to the NASA Access Help Desk at (301) 621-0134
- Telephone the NASA Access Help Desk at (301) 621-0390
- Write to:
NASA Access Help Desk
NASA Center for AeroSpace Information
7121 Standard Drive
Hanover, MD 21076

Acknowledgments

The author would like to thank Michael Stewart of Micromatic Textron for his assistance in base and plateau honing the liner segments.

Available from

NASA Center for Aerospace Information
7121 Standard Drive
Hanover, MD 21076
Price Code: A03

National Technical Information Service
5285 Port Royal Road
Springfield, VA 22100
Price Code: A03

THE INFLUENCE OF HONING ON THE WEAR OF CERAMIC COATED PISTON RINGS AND CYLINDER LINERS

Kevin Radil
U.S. Army Vehicle Technology Directorate
National Aeronautics and Space Administration
Glenn Research Center
Cleveland, Ohio 44135

SUMMARY

Reciprocating wear tests were performed to investigate the effects of honing on the wear of ceramic coated piston rings and cylinder liners. The baseline or control cases consisted of testing ceramic coated rings against ceramic coated liner specimens whose surfaces were ground and lapped smooth. A second series of tests were performed with liner specimens with base and plateau honed surfaces. Test conditions were chosen to simulate the temperatures, pressures, and boundary lubricated conditions present at top ring reversal in a conventional diesel engine. Wear factor comparisons between the baseline cases and the tests with the honed liner specimens indicate that honing alone is not sufficient to ensure an improvement in ring and liner wear.

INTRODUCTION

Much of the tribological research supporting the development of advanced diesel engines has been focused on ascertaining acceptable ceramic coating combinations for the piston rings and cylinder liners that can endure the high temperatures and pressures predicted to occur at top ring reversal (TRR) (ref. 1). The candidate materials must also equal or surpass the operating performance of current metallic ring coatings (electroplated chrome, molybdenum) and bare cast iron cylinder liners. Lubricated reciprocating wear tests on various ceramic coated ring and liner specimens at conventional diesel engine TRR conditions have consistently demonstrated that the ceramic materials possess poor wear resistance suggesting that they are inadequate choices for advanced heat engines (refs. 2 and 3). However, these test results do not necessarily provide conclusive evidence that ceramics are unsuitable engine materials. One reason for this is that some aspects of the test methods used to evaluate them do not truly represent actual operating parameters that will exist in an advanced diesel engine.

For example, one aspect under scrutiny is the practice of using modern diesel engine oils as the lubricant for the tests. These engine oils contain chemical additives that are tailored for use with the cast iron cylinder liners and the metallic coated piston rings. Depending on the additive, boundary lubricant films can be formed by decomposition, absorption, or chemical reaction (ref. 4). Either individually or collectively, the films help to minimize ring and liner wear. Unfortunately, there do not exist any available chemical additives that are specifically designed for ceramic materials, especially considering the operating temperatures that are predicted. Therefore, testing of ceramics in conventional engine oils may produce negatively misleading results.

Another aspect is that many of the coated liner specimens used for testing have a lapped (smooth) surface that is quite different than the complex microgeometry of the cast iron liners being used in today's heavy-duty diesel engines. The surface microgeometry of the liner is important because it directly affects the operating conditions of the piston rings and cylinder liners by minimizing the high wear rate during the period of "running-in" (ref. 5). Running-in occurs during the early stage of an engine's life and is associated with an adhesive wear mechanism that causes the piston ring and cylinder liner to generate conforming surfaces which helps the ring to form an effective seal and allows it to carry the imposed pressure loads.

To minimize the amount of wear during the early stages of an engine's life, diesel engine manufacturers produce cylinder liners with a bore microgeometry that resembles a surface that results from the running-in period. Producing the run-in surface requires two manufacturing processes, base honing and plateau honing. Base honing is performed after the initial boring process and selectively removes a small amount of stock from the bore to obtain a precise diameter. It is during the base honing process that the familiar crosshatch pattern, characterized by asperity peaks and deep valleys, is implanted on the surface. Plateau honing is then used to remove the asperity peaks and any attached debris remaining from the base honing process without altering the deep valleys of the crosshatch surface.

Fabricating a run-in surface during production of cylinder liners has shown to provide a number of advantages (ref. 6). For instance, tests on engines incorporating plateau honed liners have shown an 80 percent decrease in oil consumption when compared to an engine with liners that were just base honed. Another advantage is lower ring wear because ring material is not sacrificed to produce the run-in surface and the metal removed from the asperities during plateau honing remain in the honing machine instead of in the engine's lubricating oil.

It is highly probable that ceramic coated rings and liners will also experience the high wear rate associated with a running-in period. Conducting wear tests on ceramics with lapped surfaces is not a true measure of performance because the surface finish is not optimized. This may be contributing to the unsatisfactory wear results obtained from previous reciprocating wear tests on ceramics (refs. 2 and 3).

The purpose of this research is to determine if more appropriate surface finishing can improve the overall wear of ceramic coated piston rings and cylinder liners. To test this concept, a commercial spray shop was contracted to apply a ceramic material to the inner bore of cylinder liner segments using plasma and high velocity oxygen fuel (HVOF) spraying techniques. The coated liner segments were either ground and lapped to a smooth finish or base and plateau honed to a surface finish resembling cast iron cylinder liners currently in use. The segments were then cut into liner specimens and tested against four different ceramic coated rings under simulated TRR diesel engine conditions. The effectiveness of the base and plateau honing processes at reducing wear was ascertained by comparing the wear data from the smooth and honed liner tests.

Liner Specimen Preparation

The liner specimens were prepared from cast iron liners that had an inside diameter of 130 mm and an outside diameter of 147 mm. Cylindrical liner segments were obtained by cutting the liners every 60 mm in the radial direction with a band saw. The inner diameter surface of each liner segment was sand blasted in preparation for coating. The ceramic material, a commercially available tungsten carbide (WC)-cobalt (Co) composition, was sprayed on the inner diameter surface of four liner segments. As shown in table I, the coating designated as PS WC was applied to two of the cylindrical liner segments using plasma spraying and the other coating, HVOF WC, was applied to the remaining two segments using HVOF. Both were sprayed until a thickness of ~0.50 mm was reached. After spraying the coated surface was subjected to the honing processes or ground and lapped.

Honing Process.—Base and plateau honing was performed according to the operating parameters shown in table II. The base honing process etched a distinctive crosshatch pattern on the surface of both coatings as shown in figure 1. The angle of the crosshatch is dependent upon the stroke and rotational speed of the honing stone and was measured to be ~36° to 41°. After plateau honing, the inner diameter of the segments was ~126 mm and the final coating thickness was 0.25 mm. Representative surface traces of the honed PS WC and HVOF WC liner specimens, showing flat asperity peaks and deep valleys, are shown in figure 2.

Examining the liner segments after the honing revealed that the PS WC surface contained pits due to the diamond abrasive used during the base honing process. These pits can be seen in figure 1(a). One possible explanation is that the depth of cut exceeded a critical value and microbrittle fracture occurred causing pitting (ref. 7). Conversely, the same base honing parameters produced a clean, sharp cut on the HVOF WC coating, figure 1(b). This result may indicate that the spray method used to apply the coating may influence the honing of ceramic materials. After surface treatment the liner segments were cut into test specimens as described in reference 8.

Grinding/Lapping.—The liner segments that were not honed were ground and lapped to a smooth surface finish and then cut into specimens. Surface roughness measurements were taken of each liner specimen in directions parallel and perpendicular to ring motion. For both directions, the surface finish was ~0.1 to 0.2 μm R_a for the HVOF WC liner specimens and 0.4 to 0.6 μm R_a for the PS WC liner specimens.

Ring Specimen Preparation

Preparation of ring specimens began with obtaining uncoated tapered face keystone piston rings made from SAE 9450 stainless steel. In their unconstrained state, the rings are not perfectly circular but possess a varying diameter that makes any accurate surface treatment difficult. To solve this problem, each ring was placed inside of a liner segment and then the ends located at the free gap were welded together to retain the rings in it's compressed state.

After welding, the ring's outer diameter surface was coated with one of the four different commercially available coatings shown in table I. The first two, PS WC and Cr₂O₃, were applied using plasma spraying and the last two coatings, HVOF WC and CrC, were applied using HVOF. Coating thickness was measured to be 0.40 to 0.50 mm. After spraying, a crown radius of 7 to 13 mm. was ground and lapped on the ring. Surface roughness of the rings depended upon the material but was typically less than 1.2 μm R_a. The final coating thickness ranged from 0.25 to 0.38 mm. After the surface treatment the rings were cut into test specimens as described in reference 8.

TRIBOLOGICAL WEAR TESTING

Prior to testing, the liner and ring specimens were ultrasonically cleaned first in hexane and then in ethyl alcohol. Each cleaning lasted for 10 min.

The specimens were tested in the reciprocating test rig described in detail in reference 8 and shown in figure 3. The test parameters, listed in table III, were chosen to simulate the severe temperature and pressure present at TRR during engine operation under steady-state full load conditions.

Throughout the duration of the test coefficient of friction values were collected once per minute at the midpoint of the stroke.

Wear was measured on the specimens in two different ways. The liner wear was measured with a stylus profilometer and the wear on the ring was determined by using an optical microscope. A detailed description on the use of the profilometer and microscope to measure the wear on the test specimens can be found in reference 8.

Previous baseline tests using chrome ring and cast iron liner specimens, as reported in reference 8, demonstrated that the test method produced friction values that were repeatable to within 5 percent and ring and liner wear factor data was repeatable with respect to the data's order of magnitude. Therefore, it was felt that only one test per ceramic coating combination was necessary.

RESULTS AND DISCUSSION

The resulting wear scar on the ring and liner specimens had a smooth and glossy finish indicating the presence of a fine polishing wear mode thus suggesting that only submicron wear particles are being generated. Obtaining polished wear scars are important for two reasons. First, by reproducing a polishing wear mode, the test method is accurately simulating the same type of wear mechanism that controls the piston ring and cylinder liner wear in a conventional diesel engine. Secondly, due to their small size, any ceramic wear particles suspended in the engine's motor oil will cause wear on engine components equivalent to the wear from metal wear particles.

The friction and wear data for the tests with the PS WC and HVOF WC liner specimens are shown in tables IV and V, respectively.

As can be seen in table IV, the tests involving the PS WC liners produced ring and liner wear factors on the order of 10⁻⁸ for each ring material. The only exception is the Cr₂O₃ ring test against the honed liner. Wear measurements of the liner using the profilometer were unsuccessful because it was difficult identifying the wear scar from the surface trace. A closer examination of the liner surface with an optical microscope revealed the existence of a black material deposited in the liner's honing marks. EDS X-ray analysis of the liner detected the ring's coating, as evidenced by the presence of Cr and O₂, in the honing marks which confirms material transfer occurred.

By directly comparing wear factor results for the tests involving smooth and honed liner surfaces it can be seen that honing did not have any effects on the wear of the specimens.

The wear results for the HVOF WC liners in table V are very similar to what was observed with the PS WC liners except for the tests using the PS WC and HVOF WC coated rings. Testing the HVOF WC ring against the smooth liner specimen yielded ring and liner wear factors on the order of 10⁻⁹ and 10⁻⁸, respectively. When the same ring was tested against a honed liner, the magnitude of the ring wear factor increased to 10⁻⁸ while the liner wear remained constant. This phenomenon also occurred when the PS WC ring was tested. For the smooth liner case, the magnitude of the ring and liner wear factors was 10⁻⁹ and 10⁻⁸, respectively. However, when tested against the honed liner, the magnitude of the wear factor for the ring jumped to 10⁻⁸ while the liner wear remained constant.

In order to put the magnitude of the test data into perspective, wear factor values are provided for comparison. For a conventional diesel engine the wear factors were calculated to be on the order of 10⁻¹⁰ for the ring and 10⁻⁹ for the cylinder liner. These values were based on wear measurements taken of a piston ring and cylinder liner that

were removed from a diesel engine that operated for ~400,000 miles before being overhauled (ref. 8). Due to the longevity of these engines, ceramic coated rings and liners would also have to have equal or greater life expectancy than their conventional counterparts. This means that ceramic coated rings and liners must attain wear factors that are of the same order of magnitude, 10^{-10} and 10^{-9} mm³/N-m, respectively.

According to the test results, ceramic coated rings operating against ceramic coated liners with smooth surfaces do not provide the wear resistance needed for long-term operation in a conventional diesel engine. Direct comparisons between the wear factors for the smooth and honed cases indicates that honing of the liner is not sufficient to reduce the wear of either the ring or liner specimen. In fact, for the PS WC/HVOF WC and HVOF WC/HVOF WC coating combinations, honing caused an increase in ring wear.

However, the test results do not fully answer the question of whether the benefits of honing can be extended to ceramic materials. The present consensus held by researchers is that new lubrication concepts are needed before ceramic materials can be seriously considered for friction and wear applications (ref. 9). The tests reported in this paper were conducted with a liquid lubricant that contains additives that are specifically developed for the metallic ring and liner materials present in conventional diesel engines. Even though the oil used for the tests exhibited some ability to lubricate the ceramic surfaces, it is unknown if film formation was responsible. Therefore, it is recommended that future tests be conducted on the effects of honing when engine oils designed for ceramic materials become available.

CONCLUSIONS

1. The surface finish of the wear scars on the ring and liner indicates that the test method is accurately simulating the polishing wear mechanism that has been observed on actual engine hardware.
2. The differences between the honed surface finishes of the plasma sprayed and HVOF coatings suggests that the technique used to apply a ceramic material may determine whether or not the honing process can be performed on a ceramic material.
3. Relying exclusively on base and plateau honing processes to reduce friction and wear of ceramic coated rings and liners is an ineffective approach.
4. The ability of the conventional engine oil to lubricate the ceramic materials in this report is unknown and warrants further study. Engine oils compatible with ceramics must be developed in order to accurately determine the effects of honing on the wear of ceramic coated piston rings and cylinder liners.

REFERENCES

1. Bjorndahl, W.D., "Improved Piston Ring Materials for 650 °C Service," NASA CR-175058, 1986.
2. Naylor, M.G.S., "Development of Wear-Resistant Ceramic Coatings for Diesel Engine Components," DOE-ORNL Subcontract No. 86X-SA581C, 1992.
3. Gaydos, P.A. and Dufrane, K.F., "Studies of Dynamic Contact of Ceramics and Alloys for Advanced Heat Engines," ORNL/Sub/84-00216/2, 1993.
4. Stedt, P., "Influence of Lubricating Oil Additives On Friction of Ceramics under Conditions of Boundry Lubrication," Nordic Symposium on Tribology, Lulea University of Technology, Lulea, Sweden, June 15-18, 1986.
5. Pawlus, P., "A Study on the Functional Properties of Honed Cylinder Surfaces During Running-In," *Wear*, 176 (1994) pp. 247-254.
6. Fisher H., "Honing A Production Bore Size and Finishing Process," *Carbide and Tool Journal*, vol. 17, no. 2 pp. 16-20 Mar/Apr, 1985.
7. Westkamper, E. and Hohne, L., "Honing of Advanced Ceramics," *International Honing Clinic*, Detroit, MI, April 7-9, 1992.
8. Radil, K.C., "Test Method to Evaluate Cylinder Liner-Piston Ring Coatings for Advanced Heat Engines," NASA TM-107526, 1996.
9. Erdemir, A., Erck, R.A., Fenske, G.R., Hong, H., "Solid/Liquid Lubrication of Ceramics at Elevated Temperatures," 11th International Conference on Wear of Materials, San Diego, CA, April 21-24, 1997.

TABLE I.—COMPOSITION OF TEST COATINGS

Designation	Composition	Specimen	Application method
PS WC	WC - 12%Co	Ring, Liner	Plasma spraying
Cr ₂ O ₃	Cr ₂ O ₃	Ring	Plasma spraying
HVOF WC	WC - 12%Co	Ring, Liner	HVOF
CrC	CrC - NiCr	Ring	HVOF

TABLE II.—OPERATING PARAMETERS FOR THE BASE AND PLATEAU HONING PROCESSES

	Base Honing	Plateau Honing
Stone abrasive	Diamond MBG600 120/140 P 50	Diamond RVG 15/25 X 20
Stone stroke speed	230 mm/sec	230 mm/sec
Stone rotational speed	120 rpm	120 rpm
Coolant	Petroleum-based cutting fluid at 12 percent concentration	Petroleum-based cutting fluid at 12 percent concentration

TABLE III.—WEAR TESTING PARAMETERS

Speed	20 Hz
Load	192 N (32 N/mm)
Temperature	200 °C
Time	24 hr
Stroke length	15 mm
Lubrication	15W-40, oil drip 1 drop every 20 sec

TABLE IV.—FRICTION AND WEAR FACTORS FOR HONED AND SMOOTH PS WC LINERS

Ring coating	Liner coating	Ring wear factor mm ³ /N-m	Liner wear factor mm ³ /N-m	Average friction coefficient
HVOF WC	PS WC	1.28×10 ⁻⁸	5.43×10 ⁻⁸	0.081
HVOF WC	Honed PS WC	1.75×10 ⁻⁸	1.73×10 ⁻⁸	0.085
PS WC	PS WC	1.54×10 ⁻⁸	2.95×10 ⁻⁸	(a)
PS WC	Honed PS WC	2.06×10 ⁻⁸	2.55×10 ⁻⁸	0.088
CrC	PS WC	1.55×10 ⁻⁸	6.49×10 ⁻⁸	(a)
CrC	Honed PS WC	1.12×10 ⁻⁸	2.19×10 ⁻⁸	0.083
Cr ₂ O ₃	PS WC	1.15×10 ⁻⁸	3.62×10 ⁻⁸	(a)
Cr ₂ O ₃	Honed PS WC	3.34×10 ⁻⁸	Material transfer	0.085

^aNot recorded

TABLE V.—FRICTION AND WEAR FACTORS FOR HONED AND SMOOTH HVOF WC LINERS

Ring coating	Liner coating	Ring wear factor mm ³ /N-m	Liner wear factor mm ³ /N-m	Average friction coefficient
HVOF WC	HVOF WC	4.85×10 ⁻⁹	2.28×10 ⁻⁸	0.074
HVOF WC	Honed HVOF WC	1.32×10 ⁻⁸	1.06×10 ⁻⁸	0.072
PS WC	HVOF WC	4.72×10 ⁻⁹	1.15×10 ⁻⁸	0.075
PS WC	Honed HVOF WC	2.90×10 ⁻⁸	3.05×10 ⁻⁸	(a)
CrC	HVOF WC	2.62×10 ⁻⁸	1.03×10 ⁻⁸	0.086
CrC	Honed HVOF WC	1.72×10 ⁻⁸	2.58×10 ⁻⁸	0.086
Cr ₂ O ₃	HVOF WC	6.56×10 ⁻⁸	2.21×10 ⁻⁸	0.084
Cr ₂ O ₃	Honed HVOF WC	1.93×10 ⁻⁸	1.70×10 ⁻⁸	0.072

^aNot recorded.

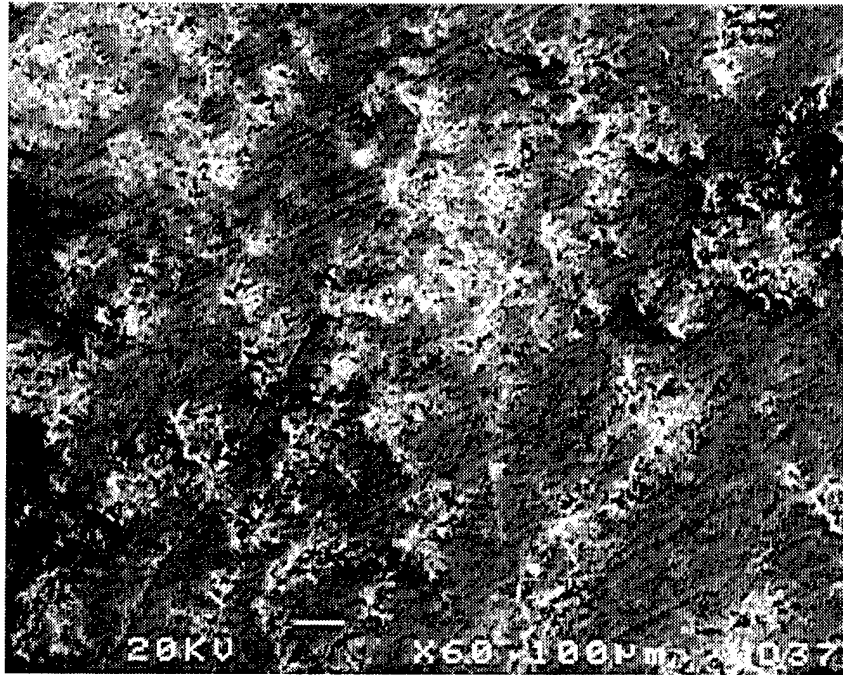

(a)

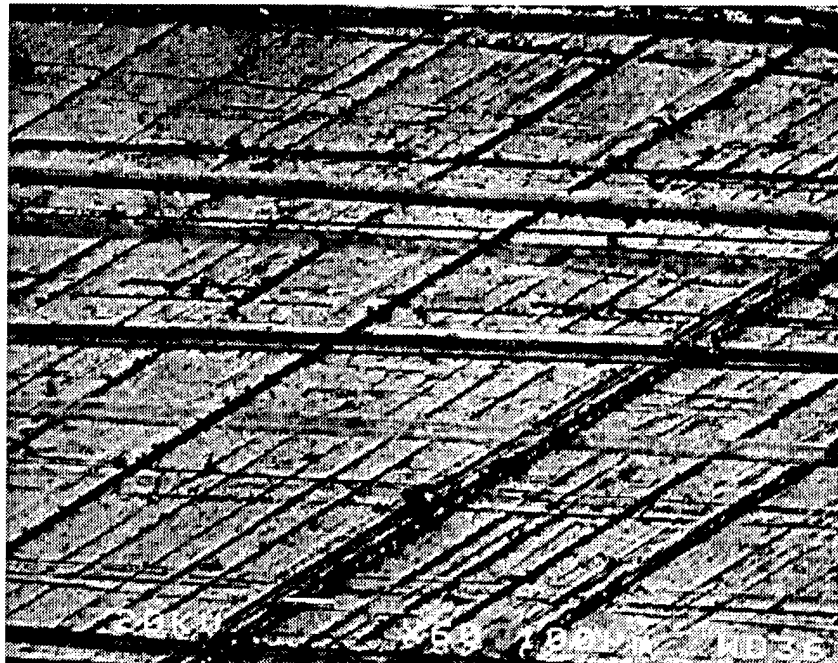

(b)

Figure 1.—SEM photographs of base and plateau honed line specimens.
(a) PS WC. (b) HVOF WC.

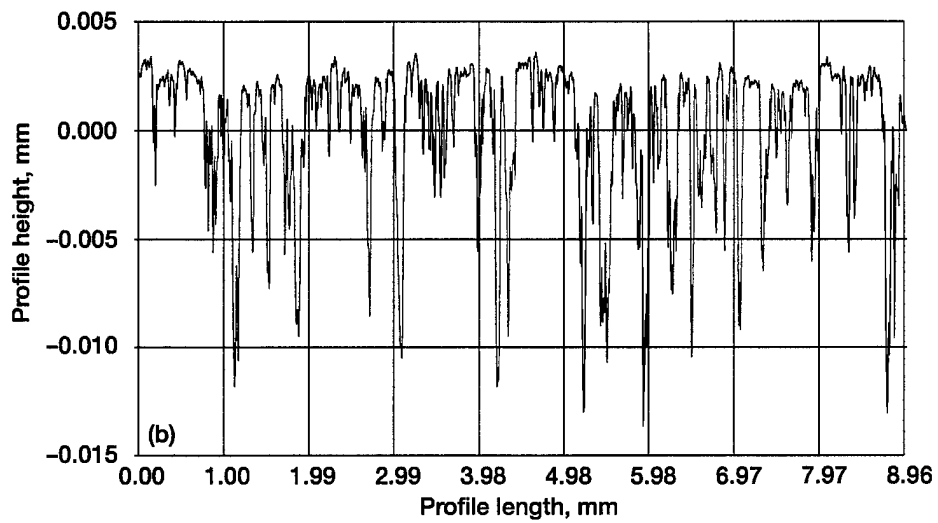
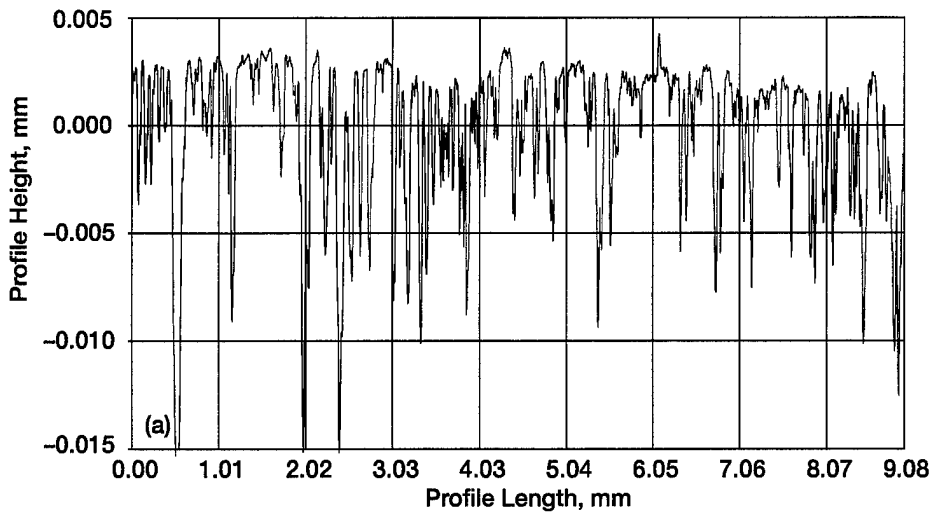

Figure 2.—Typical surface profile of liner specimens with a honed surface. (a) PS WC. (b) HVOF WC.

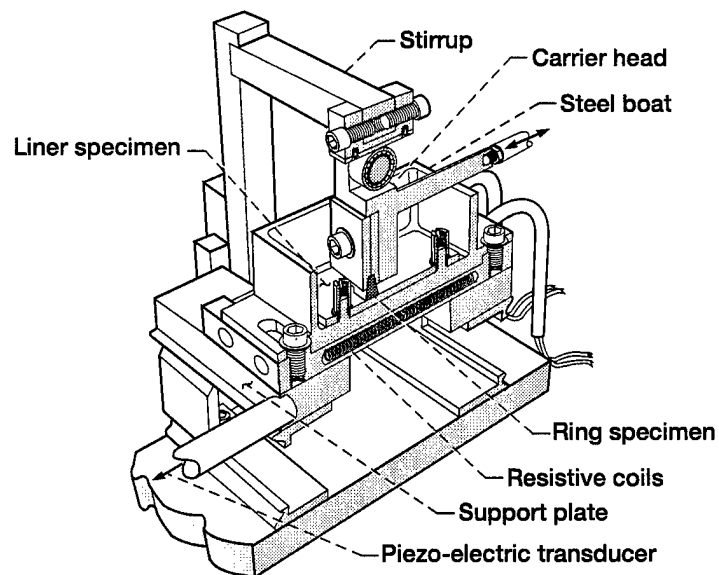

Figure 3.—Schematic of the reciprocating wear rig.

REPORT DOCUMENTATION PAGE			<i>Form Approved</i> OMB No. 0704-0188	
Public reporting burden for this collection of information is estimated to average 1 hour per response, including the time for reviewing instructions, searching existing data sources, gathering and maintaining the data needed, and completing and reviewing the collection of information. Send comments regarding this burden estimate or any other aspect of this collection of information, including suggestions for reducing this burden, to Washington Headquarters Services, Directorate for Information Operations and Reports, 1215 Jefferson Davis Highway, Suite 1204, Arlington, VA 22202-4302, and to the Office of Management and Budget, Paperwork Reduction Project (0704-0188), Washington, DC 20503.				
1. AGENCY USE ONLY (Leave blank)	2. REPORT DATE February 2000	3. REPORT TYPE AND DATES COVERED Technical Memorandum		
4. TITLE AND SUBTITLE The Influence of Honing on the Wear of Ceramic Coated Piston Rings and Cylinder Liners			5. FUNDING NUMBERS WU-523-18-13-00 1L161102AH45	
6. AUTHOR(S) Kevin C. Radil				
7. PERFORMING ORGANIZATION NAME(S) AND ADDRESS(ES) NASA Glenn Research Center Cleveland, Ohio 44135-3191 and U.S. Army Research Laboratory Cleveland, Ohio 44135-3191			8. PERFORMING ORGANIZATION REPORT NUMBER E-12084	
9. SPONSORING/MONITORING AGENCY NAME(S) AND ADDRESS(ES) National Aeronautics and Space Administration Washington, DC 20546-0001 and U.S. Army Research Laboratory Adelphi, Maryland 20783-1145			10. SPONSORING/MONITORING AGENCY REPORT NUMBER NASA TM-2000-209794 ARL-TR-2089	
11. SUPPLEMENTARY NOTES Responsible person, Kevin C. Radil, organization code 5140, (216) 433-5047.				
12a. DISTRIBUTION/AVAILABILITY STATEMENT Unclassified - Unlimited Subject Category: 23 This publication is available from the NASA Center for AeroSpace Information, (301) 621-0390.			12b. DISTRIBUTION CODE Distribution: Standard	
13. ABSTRACT (Maximum 200 words) Reciprocating wear tests were performed to investigate the effects of honing on the wear of ceramic coated piston rings and cylinder liners. The baseline or control cases consisted of testing ceramic coated rings against ceramic coated liner specimens whose surfaces were ground and lapped smooth. A second series of tests were performed with liner specimens with base and plateau honed surfaces. Test conditions were chosen to simulate the temperatures, pressures, and boundary lubricated conditions present at top ring reversal in a conventional diesel engine. Wear factor comparisons between the baseline cases and the tests with the honed liner specimens indicate that honing alone is not sufficient to ensure an improvement in ring and liner wear.				
14. SUBJECT TERMS Engines; Surface modifications; Coatings; Friction			15. NUMBER OF PAGES 13	
			16. PRICE CODE A03	
17. SECURITY CLASSIFICATION OF REPORT Unclassified	18. SECURITY CLASSIFICATION OF THIS PAGE Unclassified	19. SECURITY CLASSIFICATION OF ABSTRACT Unclassified	20. LIMITATION OF ABSTRACT	