

JPRS 68437

4 January 1977

ELECTRICAL COMMUNICATIONS ENGINEERING  
AND TECHNICAL HANDBOOK

**DISTRIBUTION STATEMENT A**  
Approved for Public Release  
Distribution Unlimited



Reproduced From  
Best Available Copy

**U. S. JOINT PUBLICATIONS RESEARCH SERVICE**

REPRODUCED BY  
**NATIONAL TECHNICAL  
INFORMATION SERVICE**  
U. S. DEPARTMENT OF COMMERCE  
SPRINGFIELD, VA. 22161

20000301 074

#### NOTE

JPRS publications contain information primarily from foreign newspapers, periodicals and books, but also from news agency transmissions and broadcasts. Materials from foreign-language sources are translated; those from English-language sources are transcribed or reprinted, with the original phrasing and other characteristics retained.

Headlines, editorial reports, and material enclosed in brackets [ ] are supplied by JPRS. Processing indicators such as [Text] or [Excerpt] in the first line of each item, or following the last line of a brief, indicate how the original information was processed. Where no processing indicator is given, the information was summarized or extracted.

Unfamiliar names rendered phonetically or transliterated are enclosed in parentheses. Words or names preceded by a question mark and enclosed in parentheses were not clear in the original but have been supplied as appropriate in context. Other unattributed parenthetical notes within the body of an item originate with the source. Times within items are as given by source.

The contents of this publication in no way represent the policies, views or attitudes of the U.S. Government.

#### PROCUREMENT OF PUBLICATIONS

JPRS publications may be ordered from the National Technical Information Service, Springfield, Virginia 22151. In ordering, it is recommended that the JPRS number, title, date and author, if applicable, of publication be cited.

Current JPRS publications are announced in Government Reports Announcements issued semi-monthly by the National Technical Information Service, and are listed in the Monthly Catalog of U.S. Government Publications issued by the Superintendent of Documents, U.S. Government Printing Office, Washington, D.C. 20402.

Indexes to this report (by keyword, author, personal names, title and series) are available through Bell & Howell, Old Mansfield Road, Wooster, Ohio, 44691.

Correspondence pertaining to matters other than procurement may be addressed to Joint Publications Research Service, 1000 North Glebe Road, Arlington, Virginia 22201.

<b>BIBLIOGRAPHIC DATA SHEET</b>	1. Report No. JPRS 68437	2.	3. Recipient's Accession No.
4. Title and Subtitle ELECTRICAL COMMUNICATIONS ENGINEERING AND TECHNICAL HANDBOOK		5. Report Date 4 January 1977	
7. Author(s) I. Ye. Golubtsova, Editor		6.	
9. Performing Organization Name and Address Joint Publications Research Service 1000 North Glebe Road Arlington, Virginia 22201		8. Performing Organization Rept. No.	
		10. Project/Task/Work Unit No.	
		11. Contract/Grant No.	
12. Sponsoring Organization Name and Address As above		13. Type of Report & Period Covered	
		14.	
15. Supplementary Notes INZHENERNO-TEKHNICHESKIY SPRAVOCHNIK PO ELEKTROSVYAZI, 1973, Moscow			
16. Abstracts  The report contains data on the construction of rural telephone networks and exchanges, multiplex equipment and telephone exchange equipment.			
17. Key Words and Document Analysis. 17a. Descriptors  USSR Communications Telephone			
17b. Identifiers/Open-Ended Terms			
17c. COSATI Field/Group 17 B			
18. Availability Statement Unlimited Availability Sold by NTIS Springfield, Virginia 22151		19. Security Class (This Report) UNCLASSIFIED	21. No. of Pages 298
		20. Security Class (This Page) UNCLASSIFIED	22. Price

JPRS 68437

4 January 1977

ELECTRICAL COMMUNICATIONS ENGINEERING  
AND TECHNICAL HANDBOOK

JPRS 68437

4 January 1977

## ELECTRICAL COMMUNICATIONS ENGINEERING AND TECHNICAL HANDBOOK

Moscow INZHENERNO-TEKHNICHESKIY SPRAVOCHNIK PO ELEKTROSVYAZI in Russian 1973 signed to press 12 Dec 72 pp 7-40, 94-231, 232-295, 425-463

[Chapters 1, 3, 4, 8 and Appendices 1-6 from the book edited by I. Ye. Golubtsova]

CONTENTS		PAGE
CHAPTER 1.	Construction of Rural Telephone Networks and the Organizational Principles of Internal Production Communications .....	1
CHAPTER 3.	The Line and Cable Installations of Rural Telephone Networks .....	42
CHAPTER 4.	Multiplex Equipment .....	189
CHAPTER 8.	Recommendations for the Project Planning of Rural Telephone Exchanges .....	255
APPENDICES	.....	273

CHAPTER 1: CONSTRUCTION OF RURAL TELEPHONE NETWORKS AND THE ORGANIZATIONAL PRINCIPLES OF INTERNAL PRODUCTION COMMUNICATIONS

Text Rural Telephone Network Design Principles

The communications in a rural area is the system of electrical communications for a rural administrative region, for the organization of which a network of lines a communications channels is created, which are the lowest link in the primary network of the Uniform Automated Communications Network of the country.

Included in the STS [rural telephone network] is the technical equipment for the telephone installations of the regional center, regionally subordinated cities, settlements of a city type and rural populated points. The telephone networks of isolated cities of an oblast' (or kray) subordination (which are not regional centers), located in a rural area, and the administrative, production and departmental telephone networks are not incorporated into the STS complement.

The automation of rural telephone communications should be realized by means of utilizing the rural, crossbar system automatic telephone exchanges, prior to the development and production of more refined automatic telephone exchange systems. City ATS's [automatic telephone exchanges] of the ATSK type [crossbar automatic telephone exchange] should be used in the telephone networks of regional centers, the capacity of which in the long term will exceed three to four thousand numbers. It is not recommended that the ten step equipment be used on the new networks of the type indicated here which are being built.

City telephone exchange communications for cities of an oblast' (or kray) subordination which are not regional centers, should be realized with the STS's through the zonal telephone network. UPATS [institutional-production automatic telephone exchanges] (or rural ATS's) which are connected into the central or junction STS exchanges should be used for institutional-production telephone networks (UPTS's) located in a rural area.

STS telephone exchanges are broken down into the following types:

- A central exchange (TsS), located at the regional center, is at the same time a city telephone exchange for the regional center. Connected into the TsS are the US [junction center] junction lines (for a two stage circuit configuration), and the junction lines of the OS's [terminal exchanges] for a one stage circuit configuration;
- Junction centers (US's), located at any populated point in the rural region. The TsS and OS junction lines are connected into the US;
- Terminal exchanges (OS's), located at any populated point in the rural region. The OS junction lines (depending on the network circuit configuration) are connected into the TsS or US.

Used in the STS is either a radial configuration, in which the rural terminal telephone exchanges are directly connected to the telephone exchange of the regional center, or a radial-junction configuration, in which the rural terminal telephone exchanges are connected to the junction centers, which in turn, are connected to the central telephone exchange at the regional center.

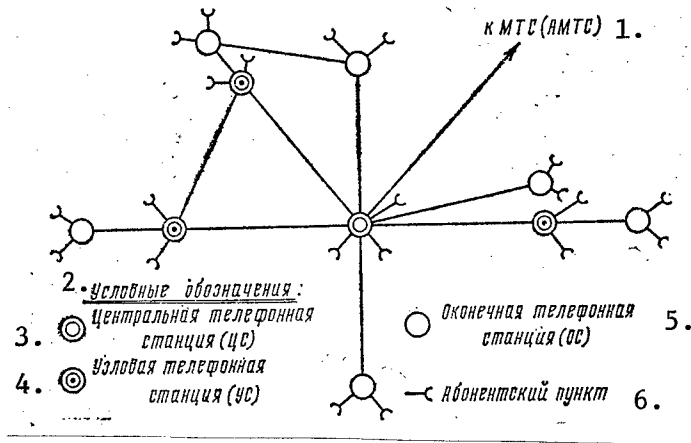

Figure 1.1. Rural telephone network configuration.

- Key: 1. To the MTS (or AMTS) [Long distance telephone exchange (or automatic long distance telephone exchange)];  
 2. Conventional symbols; 3. Central telephone exchange (TsS);  
 4. Junction telephone center (US); 5. Terminal telephone exchange (OS); 6. Subscriber point.

Depending on the circuit configuration, various numbers of communications stages are formed in the STS between the telephone exchanges (Figure 1.1).

In the case of a single stage circuit configuration, when the terminal telephone exchange is directly connected to the central exchange, terminal exchange communications with the central exchange is realized through two stages (OS - US, and US - TsS).

A single stage circuit configuration for the STS assures minimum attenuation simplifies the exchange equipment and speeds up the process of establishing the connections. For this reason, the use of the single stage configuration in a STS is the one most to be preferred and the most promising.

The two-stage STS configuration, in which part of the rural telephone exchanges are junction centers, should be used only when the conditions are expedient in an engineering and economic sense for setting up junctions.

Provisions can be made for the organization of cross communications where the conditions are quite attractive, and there is the corresponding technical and economic basis at the levels of the junction and terminal (ATS K-100/2000 and the modernized ATS K-50/200) exchanges of the crossbar and new automatic telephone exchange systems which are being developed.

#### 1.2. The Organizational Principles for Internal Production Communications

Internal production communications (VPS) are intended for assuring the efficient organization of agricultural production. VPS is created based on the use of a complex of communications equipment and installations, which are intended for the organization of:

- Internal production telephone communications (VPTS);
- Dispatcher control communications, provided for by hard wire and radio equipment.

Additionally, the following can be organized in the VPS complement:

- The transmission of information of a technological nature;
- Managerial communications;
- Personnel search public address radio installations.

The circuit for the organization of the internal production communications of agricultural enterprises is shown in Figure 1.2.

Internal production telephone communications (VPTS) is based on the utilization of the general usage rural telephone communications network (within the limits of the agricultural facility); a provision is made for the ability to limit the right of output from internal production telephone communications facilities to the general usage telephone communications network.



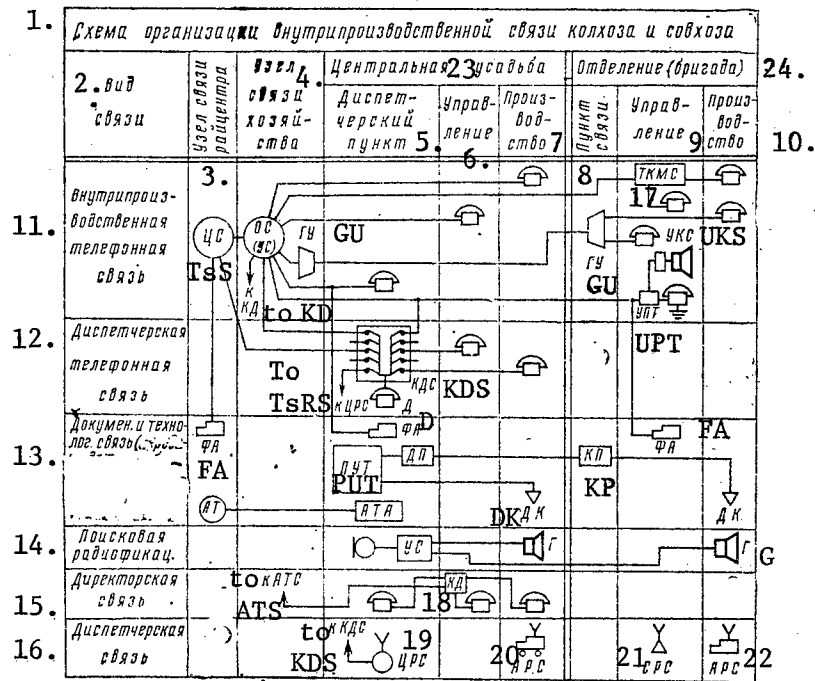

Figure 1.2. Circuit showing the organization of internal production communications for agricultural enterprises.

- Key: 1. Circuit showing the organization of kolkhoz and sovkhov internal production communications; 2. Type of communications; 3. Regional center communications junction; 4. Communications junction of the agricultural facility; 5. Dispatcher station; 6. Management; 7. Production; 8. Communications station; 9. Management; 10. Production; 11. Internal production telephone communications; 12. Dispatcher telephone communications; 13. Documentation and technological communications; 14. Public address radio installation; 15. Managerial communications; 16. Dispatcher communications; 17. TKMS, the local communications telephone complex; 18. KD, controlled terminal set; 19. TsRS, central radio station; 20. ARS, subscriber radio station; 21. SRS, fixed radio station; 22. ARS; 23. Central farm area; 24. Division (or brigade).  
 GU = Party line station; G = PA loudspeakers; DK = Monitor transducers.

Depending on local conditions, the size of the territory of the facility, the number of populated points included in it, the number of inhabitants in them and the telephone density, which determine the structure of the general usage telephone network, the following organizational methods are provided for the VPTS of kolkhozes and sovkhovs:

- Handling the telephone communications of a kolkhoz or sovkhov with one rural ATS;
- Handling the telephone communications of a kolkhoz or sovkhov with several rural ATS's, forming a telephone center;
- Handling the telephone communications of several kolkhozes or sovkhoves with one rural ATS (for small facilities, which have no developmental prospects).

Where it is technically and economically expedient, a provision is made for the use of party lines (GU), incorporated into the rural ATS's, for all the methods of kolkhoz and sovkhov telephone installation.

Local communications telephone complexes (TKMS's) and subscriber line multiplexing equipment can be used on the subscriber lines of production facilities (independently of the right of output to the general usage telephone network).

A provision is made for the joint utilization of the individual VPTS subscriber lines, which do not have the right of output to the general usage telephone communications network, for internal production, dispatcher control and loud-speaker (intercom) communications by means of a special switchboard unit.

Dispatcher control communications are intended for providing operational instructional communications (including intercom and public address communications) when introducing dispatcher control into agricultural enterprises. In the overall organization of internal production communications, hard wire dispatcher control telephone communications are, as a rule, organized in those facilities, the telephone communications of which are serviced by one or several rural ATS's. If the ATS is located in another facility, then the dispatcher control communications are organized by using radio communications equipment or installing a dispatcher switchboard.

Hard wire dispatcher telephone communications is realized through a dispatcher communications switchboard, installed in the office (administration) building of the kolkhoz or sovkhov. It is also desirable to install the rural ATS servicing the particular facility in the same building.

Brought into the dispatcher communications switchboard are:

- Independent dispatcher communications lines (channels);
- Lines used jointly for dispatcher and internal production telephone communications;
- Junction lines to the ATS servicing the facility;
- Lines to the central exchange;
- Lines to the central radio station of the facility (TsRS).

The independent dispatcher communications lines are intended for connecting the most important subscribers and production facilities located within the

bounds of the central farm or which do not have central battery ATS sets, as well as temporary field facilities to local battery type sets.

The lines employed jointly for dispatcher and internal production telephone communications are intended for connecting the production facilities of divisions or brigades which are distant from the central farm settlement (only individual lines of production facilities which do not have the right of output to the general usage telephone communications network can be used for this purpose.

The junction lines to the rural ATS provide for the ability of the dispatcher (operator) to make a connection from the dispatcher communications switchboard to the VPTS network [internal production communications network] and to the general usage telephone communications network. Dispatcher telephone communications with production facilities of divisions (or brigades) where a GU [party line station] (or OS [terminal exchange]) is installed are organized via a separate communications line (or channel), used both for dispatcher communications and VPTS. If it is impossible to make a separate line (or channel) available, then communications between these facilities and the dispatcher (operator) is organized through the rural ATS, which provides for the internal production telephone communications of the facility.

The communications of VPTS network subscribers, who have the right of output to the switched EASS [uniform automated communications network] telephone network, with the dispatcher (or operator) are provided only through the rural ATS which handles the telephone communications of the particular facility.

Dispatcher radiotelephone communications (DRS) is organized with moving, difficultly accessible and remote production facilities, and where necessary, with divisions (or brigades). Provisions are made for two DRS network configuration variants: radial and radial-cluster.

A radial network configuration is used in facilities where the production facility requires communications only with the dispatcher (or with the central radio station of the facility: the TsRS), while a radial-cluster configuration is large scale facilities. The radio stations are installed both in mobile units (subscriber radio stations, ARS's), and in division offices (fixed radio stations, SRS's), and in this case, a provision is made for tying the production facilities into not just the dispatcher of the farm facility, but also to the dispatcher-informant of his own division. A provision is made as well for specialists of the division (brigade) to use portable radio sets.

Where it is necessary to increase the communications range in a set direction, or communications must be organized in a limited territory which is not contiguous with the main territory of the facility, an individual, remote fixed radio station having a junction wire communications line to the dispatcher board is used, or an individual radio communications link is organized for that direction.

All radio stations of the DRS network operate in one simplex channel. Communications in the network is realized using a general audio call where the requisite subscriber is called "by voice".

The organization of a DRS is accomplished using radio frequencies designated in a set order by the local organs of the State Electrical Communications Inspectorate. Predominantly used for these purposes are radio frequencies in the 33 to 46 MHz and 57 to 57.5 MHz, as well as the 1.6 to 2.0 MHz bands.

The transmission of information of a technological nature is provided for to remotely monitor production processes in agriculture by means of remote control, telemetry and remote signaling, i.e. the use of remote control equipment which makes it possible to meter, record and transmit information in a form convenient for operational production control.

The transmission network for information of a technological nature consists of one dispatcher terminal set (DP), controlled terminal sets (KP), monitor transducers (DK) and lines connecting them together. Signals coming from the DK's, which are located at the production facilities of the divisions (or brigades), are picked up by the KP's, transmitted to the DP and registered on the remote control panel, installed in the dispatcher facility.

The lines from all controlled terminal sets and those monitor transducers which are located at the production facilities within the bounds of the central farm settlement are connected directly to the dispatcher terminal set. The lines from the remaining monitor transducers, located at facilities in departments (or brigades) are brought directly into the corresponding controlled terminal sets.

For controlled terminal set communications with a dispatcher terminal, the line installations of the STS are used. In this case, the communications are realized in the following manner:

- If the facility is serviced by several telephone exchanges and the communications between them are realized via channels formed by multiplexing equipment, then isolated high frequency channels are used for transmitting the remote control signals, and individual physical circuits are separated out for audio frequency communications;
- If the facility is serviced by one telephone exchange without a party line, or with a party line, then for controlled terminal set communications with the dispatcher terminal, either physical circuits or high frequency multiplex channels which are organized on the subscriber lines are used.

Individual physical circuits are used for monitor transducer communications with a controlled terminal set or dispatcher terminal.

The transmission of technological information signals can be realized via cable and overhead air lines with the utilization of standard audio frequency (0.3 - 3.4 KHz) and high frequency rural telephone communications channels. The following signals can be transmitted via physical, balanced audio frequency circuits, which are made available for the purposes of remote control, and are placed on one cable or one open air communications line section:

- DC at a voltage no higher than 60 V with a pulse width of no less than 40 msec;

-- AC in a passband of 0.3 - 3.4 KHz at a voltage of no more than 12 V.

For transmitting remote control, remote monitoring and telemetry signals via high frequency channels, the permissible levels of the AC signals should not exceed the levels of the standard signals fed to the HF input of the equipment.

No provision is made for transmitting DC signals via HF channels.

Managerial communications can be organized at large scale and average sized kolkhozes and sovkhozes for operational communications between the facility manager and the main specialists, departments and offices of the facility.

Radio public address personnel search communications are provided at the large scale production facilities of kolkhozes and sovkhozes (machinery yards, grain threshing areas, etc.) to search for and notify a set circle of personnel by means of loudspeakers. Both independent lines and secondary multiplex channels of radio links (with the condition that the multiplexing does not influence the use of these links for broadcast purposes) can be used as line units for public address communications.

### 1.3. Rural Telephone Network Numbering Schemes

#### General Considerations

The decisive factor determining the choice of the numbering scheme is the capacity of the telephone network. The capacity of an STS [rural telephone network] is defined as the number of telephones: for general use (for the home and the national economy), for kolkhoz and sovkhoz ATS's, and telephones for agency ATS's, from which one can make an outside connection. Also belonging to the STS are subscribers of the regional center, city and working settlements of a regional subordination<sup>1</sup>.

Rural telephone networks have a number of specific features which influence the choice of the numeration scheme.

1. The significant number of independent populated points scattered over a large territory.
2. The significant predominance of internal exchange messages at the individual points over external ones (interexchange ones). This is explained by the fact that in the initial period of STS development, with a relatively low telephone density, rural communications are primarily the internal production communications of the kolkhozes and sovkhozes.
3. The predominance in external message traffic of interchange with the regional exchange, where the party, soviet and other supervisory organs are concentrated.

---

<sup>1</sup> A five place numeration scheme has been adopted for STS's in accordance with the proposed final long range capacity of the networks.

4. The predominance of low capacity telephone exchanges (up to 100 numbers) especially during the initial stage of the development and automation of telephone communications for rural regions.

5. A radial-junction network configuration, where connections from subscriber to subscriber can pass through a large number of exchanges (OS - US - TsS - US - OS).

Two basic types of numbering schemes can be used in telephone networks: closed (the subscriber is called by dialing the same number of digits, independently of the location of the calling point); and open (the subscriber is assigned a number with a differing number of digits, depending on from where he is called).

Preference is to be given to an open numbering scheme in the initial stage of STS development, within the bounds of the individual rural exchanges: a numbering scheme of two to five numbers, and for interexchange traffic: a five digit numbering scheme. In the regional center, where a relatively large capacity exchange is installed, it is expedient to have five digit numeration right away.

The practical capacity of a numeration scheme, i.e. the number of telephones which can be connected into the telephone network is less than the theoretical, since part of the digit combinations are used for abbreviating the numbers of special services (00 - 09) and output to intercity telephone exchanges in the case of automated intercity communications (digit 8), while part of the number groups is not used completely; as a consequence of this, more than 20% of the subscriber numbering scheme is lost. Additionally, for ATS's with a capacity less than 100 numbers, an entire hundreds number group is set aside in the numbering scheme, and for ATS's of less than 1,000 numbers, an entire thousands group is set aside, etc. These losses in the numeration capacity are explained only by the fact that they are indispensable in a ten step ATS system with direct control, but also by the fact that it is always necessary to reserve a certain number capacity to expand the ATS in the future.

In planning the numbering scheme on rural networks, the effective utilization factor for the numeration is assumed to be roughly 0.3 - 0.4. With a growth in the capacity of the individual ATS's, the utilization factor for the numeration increases, and for long range planning, the utilization factor for the numeration can be 0.6.

The automatic equipment system being employed is of considerable importance in working out the numbering scheme for rural telephone networks. Crossbar (sending) ATS systems, where necessary, suppress superfluous or repeat certain digits in the number. These systems make it possible to select at each stage in the development of the network, independently of the network circuit configuration, the most expedient numeration scheme for the specific conditions. In systems with direct control, the choice of the numbering scheme depends to a large extent on the circuit configuration of the particular rural telephone network.

### Closed Numeration

Closed, five digit numeration is used in a STS if the following conditions are observed:

1. A large telephone density; high capacity exchanges are installed at populated points, for example, of the ATS K-100/2000 type, and the numeration within the exchange differs only insignificantly from the interexchange numeration.
2. Interexchange communications predominates over local communications.
3. The preponderant number of exchanges in the network, based on their technical capabilities, permit the use of five digit numeration (terminal exchanges and junction centers of the ATS K-100/2000 type and ATS K-50/200-M type when the three digit registers are replaced by five digit ones; central exchanges of the ATS K-100/2000 type).

In the case of closed numeration, calling up the regional center special services, including long distance exchange call order services, is accomplished by all subscribers by dialing the abbreviated numbers 00 - 09, while output to the automatic long distance exchange is accomplished by dialing the index 8. All digits besides 0 and 8 can be used as the first digits of the five digit subscriber numbers. In this case, the overall theoretical capacity of the network is 80,000 numbers, while practically, no more than 30,000 telephones may be connected into the telephone network (with the final long term growth of the network up to 60,000 telephones).

### Open Numeration with the Output Trunk Code

The following variations of open numeration with the output trunk code are used:

1. For communications within its own junction region, the five digit number is dialed without the trunk output index code, while in the case of communications through the central exchange, the trunk output code to the central exchange, the number 0, is dialed before the five digit number. Special services of the regional center are called by the central exchange subscribers by dialing two digit numbers, 00 - 09, and by subscribers of the remaining regional ATS's, by dialing three digit numbers, X00 - X09, where X is a single digit code. The number of junction centers in this is determined depending on the type of terminal ATS's. It is necessary to assign each junction its own first digit for the five digit number, different from that of the other junctions. Consequently, the number of junction regions should not exceed the number of first number digits, provided for at the terminal exchange for calling up the junction center.

Shown in Table 1.1 are the abbreviated subscriber numbers and first digits of the ATS codes, for which the rural exchange circuits are designed.

Table 1.1. Numeration Schemes for Rural Automatic Telephone Exchanges

ATS Type and Capacity	Abbreviated Subscriber Numbers	Code of the Output Trunk to: TsS	MTS	First Digits of the Call-up Numbers:	
				US	OS
Terminal, relay ATS, VRS-20M for 20 Nos.	40-59	0	-	1 - 3 6 - 9	-
Unit, relay, terminal ATS-10/40 for 40 No	10-49	0	-	6 - 9	-
Ten step, terminal ATS 50/100 for 50 Nos.	10-59	0	-	7 - 5	-
Ten step, junction ATS-50/100 for 50 Nos.	10-59	0	-	-	60-99
Ten step, junction ATS-50/100 for 80 Nos.	10-89	0	-	-	90-99
Ten step, terminal ATS-100/500 for 500 Nos.	200-699	0	-	7 - 9	-
Ten step, junction ATS-100/500 for 500 Nos.	200-699	0	-	-	7 - 9
Ten step, central ATS-100/500 for 500 Nos.	200-699	-	8	7 - 9	7 - 9
Crossbar, terminal ATS K-40/80 for 40 Nos.	10-59	-	8	6 - 7 & 9	-
Crossbar, junction ATS K-40/80 for 40 Nos.	10-59	-	8	-	6 - 7 & 9
Crossbar, terminal ATS K-50/200 for 200 Nos.	100-299	-	8	3 - 7 & 9	-
Crossbar, junction ATS K-50/200 for 200 Nos.	100-299	-	8	-	3 - 7 & 9
Crossbar, terminal ATS K-100/2000 for 700 Nos.	100-799	-	8	9	-
Crossbar, junction ATS K-100/2000 for 700 Nos.	100-799	-	8	-	9
Crossbar, central ATS K-100/2000	-	-	8	1 - 7 & 9	1 - 7 & 9

Key: TsS = Central exchange; MTS = Long distance exchange;  
 US = Junction center; OS = Terminal exchange.

2. The call-up of a terminal ATS subscriber, connected into his own junction center, is accomplished by dialing a special code for the output trunk to the junction center (the digit 9), while call-up through the central exchange is



accomplished by dialing the code of the output trunk to the central exchange (the digit 0). The five digit number of the subscriber is dialed after the index. Special services are called by dialing the numbers 000 - 009, while the output trunk to the automatic long distance telephone exchange is dialed using a two digit output trunk code, 08. This variant is employed when the junction center is a ten step exchange system.

3. Calling up any subscriber in the network (besides a subscriber of one's own exchange) is accomplished from terminal and junction centers by dialing the code of the output trunk "upward" (the digit 9) and the five digit inter-exchange number of the subscriber. The numbers of the special lines are 900 - 999, while the code for the output trunk to the automatic long distance exchange is 98. This numbering scheme is employed in a network with a crossbar system junction center (40/80, 50/200, 100/2000).

4. If there are crossbar and ten step system junction centers on the same network, a mixed variant is employed, where the terminal exchanges connected into the ten step system junction centers realize interexchange communications using variant 2, while the terminal stations connected into the crossbar system junction centers use variant 3.

In all cases, central exchange and ATS K-100/2000 (as well as modernized K-50/200M ATS's with five digit registers) subscribers call any subscriber by directly dialing his five digit number, call special services by dialing the numbers 00 - 09, and the automatic long distance exchange by dialing the trunk output code, 8.

It should be taken into account that the K-100/2000 ATS and modernized K-50/200M ATS's with five digit registers cannot be connected in as terminal stations to a ten step system junction center, while ATS-50/100 exchanges which do not provide for constant five digit numbers for interexchange communications should not be used as junction centers in the rural telephone network.

#### Open Numeration without the Output Trunk Code

In the case of open numeration without an output trunk code, the numbering scheme within the exchange is abbreviated (2 - 3 digits), while the inter-exchange is five digit. In order to differentiate the interexchange and internal exchange numbering schemes, the first digits of these numbers should be different. As a consequence of this, the capacity of the rural exchanges and the capacity of the telephone network as a whole is limited.

With an increase in the number of first digits being used in the five digit numeration, the maximum capacity of the individual rural ATS's decreases, and the numeration utilization factor also decreases. When one number is used as the first digit of five place numbers, the theoretical maximum capacity of the network is 8,000 numbers; when two numbers are used, it is 14,000 numbers, and when three numbers are used, 18,000 numbers. Increasing the

number of initial digits in five place numbers to more than three does not yield perceptible results in increasing the maximum capacity of the network, and along with this, leads to an impermissible limitation of the capacity of small ATS's

It is expedient to use open numeration without an output trunk code in those cases where the theoretical capacity of the network does not exceed 8,000 numbers, and only one initial digit allotted for the five digit numeration.

#### Numeration for Communications Through a Rural-Suburban Junction

If the regional center is a city with a regionalized telephone network, and a rural-suburban junction (SPU) for incoming and outgoing traffic replaces the rural communications central exchange, a numeration is used for inter-exchange communications between the junctions and the city subscribers which is similar as regards the number of numeration places in the city telephone network (five - seven places). In this case, subscriber call-up within the limits of his own junction is accomplished using the principles adopted for the rural telephone network by dialing the abbreviated or five digit number; call-up by the subscribers of rural networks of a city network subscriber or a subscriber of the rural network of another junction region is accomplished by dialing the code of the trunk output to the SPU (the digit 0), and after hearing the ready tone from the SPU register, subsequently dialing the number of the subscriber (five to seven digits).

The call-up of subscribers of a rural network by subscribers of a city telephone network of its own administration region is accomplished by dialing their interexchange number (five to seven digits) without the output trunk code.

#### The Numbering Scheme for Special Services

The numbering scheme for regional center special services should be two-place. The main special services should be assigned the following numbers:

Fire department	01
Police	02
First aid	03
Gas network emergency service	04
Long distance exchange call order switchboard	07
Network information service	09

Regional center services should be called from the junction centers and terminal exchanges using the same two digit numbers, not counting the code for the trunk output to the central exchange.

Junction center and terminal exchange special services are called by dialing the complete subscriber numbers in accordance with the numbering scheme adopted at these exchanges.

#### 1.4. The Attenuation Distribution and Through Call Connections in Rural Telephone Networks

The attenuation norms in rural telephone networks are established by the method of evaluating the transmission quality based on an attenuation equivalent taking into the qualitative characteristics of telephone sets used in the network, which is recommended by the International Telephone and Telegraph Consultative Committee.

The following attenuation norms at a frequency of 800 Hz have been adopted for rural telephone networks with TA-60(65) telephone sets. The speech channel attenuation from the set of a rural subscriber to the long distance exchange should not exceed 9.5 dB (1.1 Nep) (without taking into account the exchange attenuation of the long distance exchange).

This attenuation is distributed in the network in the following fashion: subscriber line, 4.3 dB (0.5 Nep); junction lines from the terminal exchange to the long distance exchange, 4.3 dB (0.5 Nep); terminal exchange attenuation, 0.9 dB (0.1 Nep).

In expanding and remodeling rural telephone networks, it is necessary to replace the old sets with TA-60(65) sets on the subscriber lines having an attenuation in excess of 2.7 dB (0.3 Nep). The old telephone sets can be used on the subscriber lines of regional centers where the entral exchange and the long distance exchange are located in one building, and consequently, the attenuation of the junction lines between the automatic telephone exchange and the long distance exchange is 0.0 dB (0 Nep).

TAU-03 telephone sets with semiconductor amplifiers are used on long subscriber lines with an attenuation greater than 4.3 dB (0.5 Nep). The maximum permissible attenuation of the subscriber line with this set, in the case of a residual attenuation of 4.3 dB (0.5 Nep) is: for cable lines, 13.0 (1.5 Nep), and for overhead open air lines, 10.4 dB (1.2 Nep).

If the distance between exchanges reaches tens of kilometers, it is expedient to use multiplex equipment. The same residual attenuation has been adopted for the multiplex channels of rural networks as for intercity channels: 6.9 dB (0.8 Nep). In the case of four wire through connections of two high frequency channels, the through attenuation amounts to 0 dB (0 Nep), i.e. the overall attenuation of the built-up channel remains equal to +6.9 dB (0.8 Nep) without loss for reliable communications, independently of the number of series inter-connected channels.

The most economic and technically efficient way to meet the attenuation norms is through the wide introduction of multiplex equipment on the rural networks

while simultaneously using four wire through connections at long distance exchanges and through call rural ATS's. The long range planning of rural telephone networks should take this condition into account. However, at the present time, there are manually serviced long distance exchanges, and rural ten step automatic telephone exchanges at the regional centers, where the organization of a four wire through connection is impossible at these exchanges. Under these conditions, technical solutions are required which would assure the observation of the norms both for two wire through connections as well as on networks with physical circuits for the interexchange junction lines.

In the overall government automatically switched telephone network system, the permissible nominal magnitude of the attenuation between network subscriber sets for the case of an intrazonal connection should not exceed 27.7 dB (3.2 Nep) at a frequency of 800 Hz. An attenuation of up to 31.2 dB (3.6 Nep) is temporarily permitted for intrazonal communications between subscribers of rural networks, and consequently, temporarily until the wide introduction of multiplex equipment and four wire through call connections, an exceeding of the norm by 1.8 dB (0.2 Nep) is permitted over the section from the rural ATS to the long distance exchange, i.e. the attenuation can amount to 11.2 dB (1.3 Nep).

Used on the rural telephone networks is a system of through connections adopted for the long distance telephone network with cutout of the through attenuator pad networks in the case of two wire through connections, which assures zero through connection attenuation. The through connection attenuator networks are cut out of the audio frequency termination complexes (KNO's) of the multiplex equipment.

A two wire through call for channels with zero through connection attenuation is permitted only temporarily, until the wide introduction of four wire through connections, since in this case the stability of the multiplex channels and the communications quality are reduced.

The long distance exchanges at regional centers are being retained only until the introduction of automatic long distance and zonal communications, and after this, long distance and intrazonal traffic for rural subscribers will be handled through the long distance automatic telephone exchange for the zone. The attenuation norm of 9.5 dB (1.1 Nep) should be observed in this case from the subscriber set to the long distance telephone exchange for the zone.

The norms adopted for rural telephone networks should also be applied for the case of communications through rural-suburban junctions.

It is recommended that the introduction of junction line multiplexing on rural telephone networks be implemented sequentially, beginning from the long distance exchange downward (long distance exchange - central exchange, central exchange - junction center, etc.). Then the norm for the residual attenuation in the long distance channel of 6.9 dB (0.8 Nep) will be extended to the rural ATS at which the transition to the physical circuit is made.

TABLE 1.2. Examples of the Attenuation Distribution for a Standard Attenuation of 11.2 dB (1.3 nepers) between the Subscriber Set and the Long Distance Exchange over Routes without Multiplex Equipment.

Варианты организации связи Communications Organization Variants	Схема построения сети Network Circuit Configuration	2. Затухание, дБ (Нп)						
		1. Рабочее затухание дБ (Нп)	3. Линейных трансформаторов	4. Станционных устройств	5. Линейное (максимальное) в том числе	6. всего	7. аб. линии	8. соедин. линии
ЦС и МТС в одном здании TSS and MTS in one building	<p>TSS = Central Exchange</p>	6.9 (0.8)	—	0.9 (0.1)	6.0 (0.7)	6.0 (0.7)	—	—
ЦС и МТС в разных зданиях TSS and MTS in different buildings	<p>MTS = Long Distance Exchange</p>	11.2 (1.3)	—	0.9 (0.1)	10.4 (1.2)	4.3 (0.5)	6.0 (0.7)	—

10. Несредствительное включение абонента -  
телефонная линия

Key: 1. Working attenuation in dB (nepers); 2. Attenuation in dB (nepers); 3. Of the line transformers; 4. Of the exchange equipment; 5. Line (maximum) attenuation; 6. Total; 7. Including; 8. Subscriber lines; 9. Junction lines; 10. Direct connection of the subscriber circuit to the central exchange.

TABLE 1.2. [Continued]

Table 1.2 Continued

Продолжение табл. 1.2

Communications Варианты организации связи Organization Variants	Схема построения сети Network Circuit Configuration	1. Рабочее затухание вдоль (Нп) (Нп)	2. Затухание, дБ (Нп)			линейное (максимальное) в том числе		
			линей- ных транс- форматоров	станци- онных уст- ройств	всего	аб. линия	соед. линия	5. 7.
ЦС и МТС в одном здании TSS and MTS in one build- ing.	<p>TSS = Central Exchange MTS = Long Distance Exchange</p>	11,2 (1,3)	0,9 (0,1)	1,8 (0,2)	8,5 (1,0)	4,3 (0,5)	4,3 (0,5)	
ЦС и МТС в раз- ных зданиях TSS and MTS in different buildings	<p>OS = Terminal Exchange TSS = Central Exchange</p>	11,2 (1,3)	0,9 (0,1)	1,8 (0,2)	8,5 (1,0)	4,3 (0,5)	4,3 (0,5)	

11.

Key: 1. Working attenuation in dB (nepers); 2. Attenuation in dB (nepers); 3. Of the line trans-  
formers; 4. Of the exchange equipment; 5. Line (maximum) attenuation; 6. Total; 7. Including;  
8. Subscriber lines; 9. Junction lines; 11. Single stage network configuration.

TABLE 1.2. [Continued]

Table 1.2 Continued

Продолжение табл. 1.2

Communications Organization Variants	Схема построения сети Network Circuit Configuration	1. Рабочее затухание ДБ (Нп)	2. Затухание, дБ (Нп)				линейное (максимальное)		
			3.	4.	5.	6.	в том числе		9.
							аб. линии	соед. линии	
ЦС и МТС в одном здании TSS and MTS in one building	<p>OS = Terminal Exchange US = Junction Center</p>	11.2 (1.3)	1.8 (0.2)	2.7 (0.3)	6.9 (0.8)	4.3 (0.5)	2.4 (0.3)		
ЦС и МТС в разных зданиях TSS and MTS in different buildings	<p>TSS = Central Exchange MTS = Long Distance Exchange</p>	11.2 (1.3)	1.8 (0.2)	2.7 (0.3)	6.9 (0.8)	4.3 (0.5)	2.4 (0.3)		

Key: 1. Working attenuation in dB (nepers); 2. Attenuation in dB (nepers); 3. Of the, line trans-  
formers; 4. Of the exchange equipment; 5. Line (maximum) attenuation; 6. Total; 7. Including;  
8. Subscriber lines; 9. Junction lines; 12. Two stage network configuration.

TABLE 1.3. Examples of the Attenuation Distribution for an Attenuation Norm of 9.5 dB (1.1 Nepers) Between the Subscriber Set and the Long Distance Exchange Over Routes with Multiplex Equipment, Two Wire Through Connections with Attenuator Pad Cutout in the Routing Equipment Complex during Intercity Communications.

Communications Variants Organizational Variants	1. Рабочее значение для (дБ) (Hп)	2. Затухание, дБ (Hп)			
		линейных трансформаторов	станционных устройств	линейное (максимальное) в том числе аб. линий	5. в том числе 7. соед. линий
10. Скелетная схема построения сети Skeleton Network Circuit Configuration	7.8 (0.9)	—	1.8 (0.2)	5.9 (0.7)	5.9 (0.7)
11. Одноступенчатое построение сети	7.8 (0.9)	—	—	5.9 (0.7)	5.9 (0.7)
12. Двухступенчатое построение сети	8.5 (1.0)	—	2.7 (0.3)	5.9 (0.7)	5.9 (0.7)

Key: 1. Working attenuation in dB (nepers); 2. Attenuation in dB (nepers); 3. Of the line transformers; 4. Of the exchange equipment; 5. Line (maximum) attenuation; 6. Of all physical circuits; 7. Including; 8. Subscriber lines; 9. Junction lines; 10. Single stage network configuration; 11. Junction lines multiplexed. Central exchange and long distance exchange in one building; 12. Central exchange and long distance exchange in different buildings. All junction lines multiplexed; 13. Two stage network configuration; 14. All junction lines multiplexed. Central exchange and long distance exchange in one building.

OS = Terminal exchange; TSS = Central exchange; MTS = Long distance exchange.



TABLE 1.3. [Continued]

Продолжение табл. 1.3

Communications Organization Variants	Скелетная схема построения сети Skeleton Network Circuit Configuration	1. Рабочее затухание (дБ) (Hп)	2. Затухание, дБ (Hп)		5. в том числе 7. в том числе 9. в том числе		
			линейных трансформаторов 3.	станционных устройств 4.		линейное (максимальное) 6. все физических цепей 8.	
10. Слуплотнены час-тично и МТС в разных зда-ниях		9.5 (1.1)	0.9 (0.1)	2.7 (0.3)	5.9 (0.7)	4.3 (0.5)	1.8 (0.2)
11. Все слуплотнены, ИС и МТС в разных зда-ниях		8.6 (1.0)	—	2.7 (0.3)	5.9 (0.7)	5.9 (0.7)	—
12. Слуплотнены час-тично, ИС и МТС в одном зда-нии		9.5 (1.1)	0.9 (0.1)	2.7 (0.3)	5.9 (0.7)	4.3 (0.5)	1.8 (0.2)

Key: 1. Working attenuation in dB (nepers); 2. Attenuation in dB (nepers); 3. Of the line transformers; 4. Of the exchange equipment; 5. Line (maximum) attenuation; 6. Of all physical circuits; 7. Including; 8. Subscriber lines; 9. Junction lines; 10. Two stage configuration; 11. Junction lines partially multiplexed. [Central exchange] and long distance exchange in different buildings; 12. All junction lines multiplexed. Central exchange and long distance exchange in different buildings; 13. Junction lines partially multiplexed. Central exchange and long distance exchange in one building. MK = Long distance cable.

TABLE 1.4. Examples of the Attenuation Distribution for an Attenuation Norm of 9.5 dB (1.1 Nepers) Between the Subscriber Set and the Long Distance Exchange Over Routes with High Frequency Multiplexing Equipment; Four Wire Through Connections.

Communications Organization Variant	Скелетная схема построения сети Skeleton Network Circuit Configuration	1. Рабочее значение затухания, дБ (Нп)	2. Затухание, дБ (Нп)				5. линеиное (максимальное)
			линейных трансформаторов	станционных устройств	всех физических цепей	в том числе аб. линия	
			3.	4.	7.	8.	9.
10. Все слуплотнены		6.9 (0.8)	—	0.9 (0.1)	5.9 (0.7)	5.9 (0.7)	—
11. Одноступенчатое		9.5 (1.1)	0.9 (0.1)	1.8 (0.2)	6.9 (0.8)	4.3 (0.5)	2.7 (0.3)
12. Все слуплотнены		6.9 (0.8)	—	0.9 (0.1)	5.9 (0.7)	5.9 (0.7)	—
13. Двухступенчатое		9.5 (1.1)	0.9 (0.1)	1.8 (0.2)	6.9 (0.8)	4.3 (0.5)	2.7 (0.3)

Key: 1. Working attenuation in dB (nepers); 2. Attenuation in dB (nepers); 3. Of the line transformers; 4. Of the exchange equipment; 5. Line (maximum) attenuation; 6. Including; 7. Of all physical circuits; 8. Subcarrier lines; 9. Junction lines; 10. Single stage; 11. All junction lines multiplexed; 12. Junction lines partially multiplexed; 13. Two stage; 14. All junction lines multiplexed; 15. Partially multiplexed [junction lines]; OS = Terminal exchange; TSS = Central exchange; MTS = Long distance exchange; US = Junction center; MK = Long distance cable.

In the attenuation distribution over the sections of the speech channel, it should be noted that in the case of four wire through connections of HF channels, the attenuation introduced by the exchange equipment of the through exchange is 0 dB (0 Nep), while in the case of two wire through connections of HF channels, it is equal to 0.9 dB (0.1 Nep).

Examples of the distribution of the magnitude of the attenuation adopted for sections of the speech channel are shown in Tables 1.2 - 1.4.

### 1.5. Rural and City Automatic Telephone Exchange Communications

#### The Organization of Automatic Telephone Exchange and Rural Telephone Network Communications with Regionalized City Telephone Exchanges

When the rural regional center is a city with a regionalized telephone network, a rural-suburban junction for incoming and outgoing SPU [rural-suburban junction] traffic (Figure 1.3) is organized in the city for communications with rural automatic telephone exchanges, where the SPU performs the function of a numberless central exchange. It is recommended that the SPU be designed around crossbar equipment to realize four wire through connections.

The subscribers of rural ATS's, connected into one junction center, are interconnected apart from the SPU. Communications between subscribers connected into different rural junction centers, are made between themselves and with subscribers of the city telephone exchange through the SPU, into which the junction lines are connected from the rural communications juncter centers and terminal exchanges. The rural subscriber output trunk is engaged by dialing the output trunk code 0. The city telephone exchange subscribers dial the number of the desired subscriber without the output trunk code.

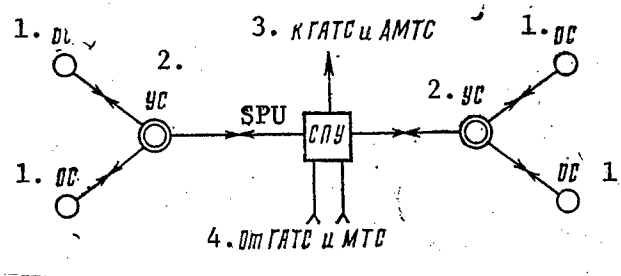

Figure 1.3. The principle of communications organization through a SPU [rural-suburban junction].

- Key: 1. OS = Terminal exchange; 2. US = Junction Center;  
 3. To the GATS [city automatic telephone exchange] and the AMTS [automatic long distance exchange];  
 4. From the GATS and the MTS [long distance exchange]

## Rural-Suburban Junctions of the ATS K-100/2000 Type

Rural ATS K-100/2000 switchboard equipment is used at a regionalized, small capacity, city telephone exchange as the SPU. Other conditions being equal, an SPU based on the ATS K-100/2000 is significantly more economical than an SPU based on city crossbar ATSK's [crossbar automatic telephone exchanges]. However, an ATS K-100/2000 city-suburban junction cannot be used in networks with six and seven digit numbering schemes, since the registers of this ATS are designed for registering only five digits of a number. As a consequence of this, an SPU based on the K-100/2000 ATS is to be designed into only those networks where the nominal capacity of the city telephone exchange and rural telephone network does not exceed 80,000 numbers (with five digit numeration).

The circuit of a rural-suburban junction ATS K-100/2000 is shown in Figure 1.4. Used in the assembly are standard group selector units, registers and RSL [line connector relay equipment] complexes. An individual junction line bundle is to be fed to each ten thousand group, separated out for the STS (or the II GI [group selector] group) from the ten step city automatic telephone exchange. Only one junction line bundle can be fed from crossbar ATS's to the inputs of the I GI (instead of the II group selector), and consequently, communications from the city telephone exchange to the STS will be realized through an additional group selector stage (the I GI). For this reason, such a circuit should be based on the technical and economic design calculations in the planning stage.

The following modernized RSL complexes are employed at SPU's:

- PKU (universal connection complex), for the organization of incoming communications with all incoming complexes and for all incoming communications via three wire junction lines instead of the RSLV-B3 complex;
- RSLI-4, for outgoing communications with the RATS [?regional automatic telephone exchange?] via three wire junction lines, instead of the RSLI-p/b3 complex, and to match the complexes of other ATS systems with SPU equipment;
- RSL<sub>ind</sub>, universal inductive equipment complex for communications via one-way and two-way junction lines with rural ATS's in place of the RSLI-I and RSLV-I. Rural type multiplexing equipment is connected into the channels through the low frequency termination complex;
- The RSLI-U and RSLV-U for city telephone exchange communications via KRR type multiplex equipment channels;
- RSLI-UM and RSLV-UM for long distance telephone exchange communications via KRR type multiplex equipment channels.

All of the complexes enumerated above provide for commutating two wire and four wire speech channels.

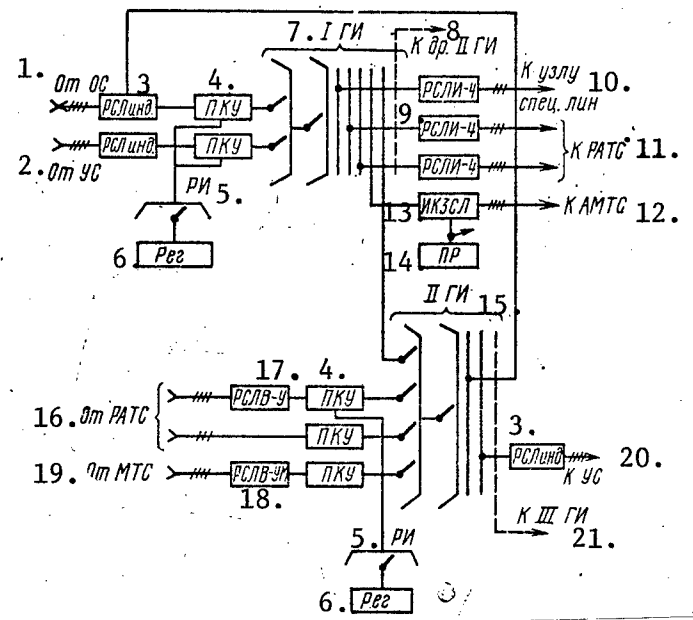

Figure 1.4. Rural-Suburban Junction Circuit of the ATS K-100/200 Type.

- Key: 1. From the terminal exchange; 2. From the junction center;  
 3. RSL<sub>ind</sub> [inductive line connector relay complex];  
 4. PKU [universal connector complex]; 5. RI [register finder];  
 6. Register; 7. I GI [group selector I]; 8. To other II GI's;  
 9. RSLI-4; 10. To special line unit; 11. To the RATS;  
 12. To the AMTS [automatic long distance exchange]; 13. IKZSL  
 [outgoing recording trunk junction line complex];  
 14. PR; 15. II GI [group selector II]; 16. From the RATS;  
 17. RSLV-U; 18. RSLV-UM; 19. From the MTS [long distance exchange];  
 20. To the junction center; 21. To the III GI.

Until industry produces modernized RSL complexes, one can use the RSLI-I, the RSLV-I, RSLI-p/b3 and RSLV-B3 complexes. The RSLU complexes of crossbar or ten step ATS's can be used temporarily for communications through KRR type multiplex equipment channels, and RSLI-p/b3 and RSLV-B3 complexes should be installed in series with the RSLU complexes to match them to the rural-suburban junction equipment. (The RSLI-p/b3 and the RSLV-B3 do not provide for the capability of organizing four wire through connections.)

Standard inductive RSL complexes of the corresponding types of ATS's, in which the corresponding resoldering of connections is made when they are used on multiplex junction lines, are employed at rural junction centers and terminal exchanges interacting with rural suburban junctions.

## Rural-Suburban Junctions of the Crossbar ATS Type

Rural-suburban junctions of the crossbar ATS type (Figure 1.5) are planned only at regionalized city telephone exchanges where junction centers are set up, i.e. with six and seven digit numeration. The connection of RSL complexes into the field and to the inputs of the GI [group selector] stages is accomplished in a manner analogous to that adopted for ATS K-100/2000 rural-suburban junctions.

The incoming junction line complexes of rural ATS's are serviced by standard ARB subscriber registers, while the junction lines from city ATS's and long distance exchanges are serviced by the incoming registers, VRDB. Standard

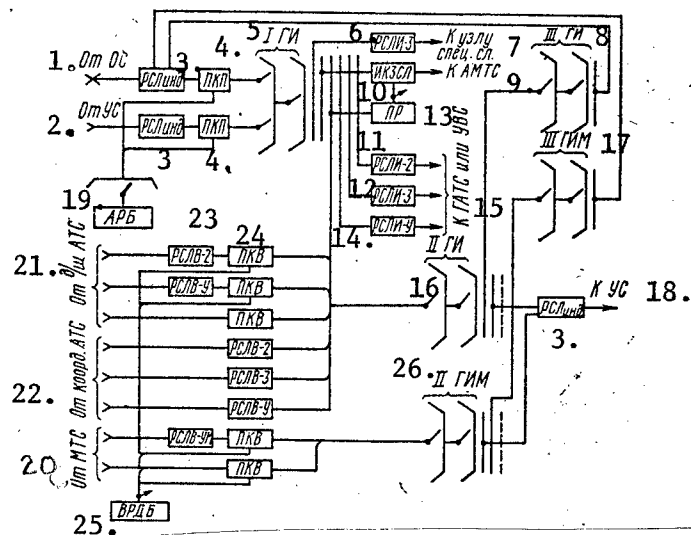

Figure 1.5. Rural-suburban junction circuit of the crossbar ATS type.

- Key:
1. From the terminal exchange;
  2. From the junction center;
  3. RSL<sub>ind</sub>;
  4. PKP [connection complex];
  5. I group selector;
  6. RSLI-3;
  7. To the special junction line assembly;
  8. III group selector;
  9. To the automatic long distance exchange;
  10. IKZSL [outgoing recording trunk junction line complex];
  11. RSLI-2;
  12. RSLI-3;
  13. PR;
  14. RSLI-U;
  15. To the city automatic telephone exchange or the UVS [expansion unknown];
  16. II group selector;
  17. III GIM [III long distance group selector];
  18. To the junction center;
  19. Subscriber register;
  20. From the long distance telephone exchange;
  21. From the ten step ATS;
  22. From the crossbar ATS;
  23. RSLV-2;
  24. PKV;
  25. VRDB [unknown type of incoming register];
  26. II GIM.

crossbar ATS line connector complexes are used for communications with the city automatic telephone exchange, while universal inductive one-way and two-way complexes (RSL<sub>ind</sub>) have been developed for communications with rural ATS's.

Crossbar ATS group selector units are the ones primarily used at the group selector stage.

The hundred thousand group is separated out in a network where a junction is set up, for the rural-suburban junction at the expense of city telephone exchange capacity.

#### The Connection of Rural ATS's to City Type ATS's

In regional centers, where city type ATS's are installed as central exchanges, the incoming junction lines from rural ATS's are connected at the crossbar ATS to the I group selector devices (connection to the registers is accomplished through the PKP's [unknown type of connection complexes]), and at the ten step ATS's, to the I/II group selector devices; the outgoing junction lines are connected into the field of the group selection stages.

Inductive line connector relay complexes, corresponding to the type of terminal exchange or junction center, are installed at rural ATS's for communications with the central exchange. RSL<sub>ind</sub> crossbar ATS complexes similar to the complexes employed in the rural-suburban junction, are installed at the city crossbar system ATS. RSL<sub>ind</sub> K-100/500 ATS complexes can be used temporarily at a ten step city ATS.

At a crossbar ATS, the group selector stages to which the junction lines are connected from the rural ATS's, should be four wire, while at a ten step ATS, it is necessary to provide for cutting out the 6.9 dB (0.8 nepers) attenuator networks in the KNO-1 audio frequency termination complexes during intercity through call channel multiplexing or with four wire lines.

In expanding or rebuilding the network, it is recommended that crossbar junction equipment which provides for four wire through connections be installed at central exchanges with ten-step equipment.

#### Switching Individual Rural Exchanges into the City Telephone Exchange

Where it is necessary to switch individual suburban exchanges of the rural type into a city telephone exchange, one can use the RSL ATS-47 (54) complexes, which are connected for incoming communications into the subscriber complexes of the city ATS, and for outgoing communications, into the field of one of the group selection stages (Figure 1.6).

In choosing this method, one should see that with this circuit the overall attenuation of the subscriber and junction line should not exceed the

attenuation norms for the subscriber line, i.e. 4.3 dB (0.5 nepers). If it is impossible to meet this condition, the communications should be organized through the SPU [rural-suburban junction].

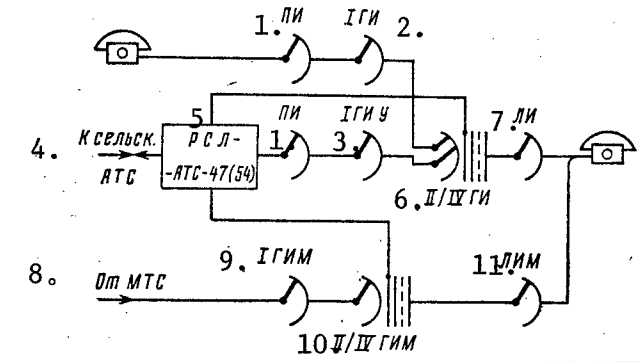

Figure 1.6. Circuit for switching individual rural ATS's into a city telephone exchange.

Key: 1. PI [preselector]; 2. I GI [I group selector]; 3. I GI U [U suffix expansion unknown]; 4. To the rural ATS; 5. ATS-47(54) RSL; 6. II/IV GI; 7. LI [line connector]; 8. From the long distance exchange; 9. I GIM [I long distance group selector]; 10. II/IV GIM; 11. Long distance line connector.

#### Rural ATS Communications with Manual Telephone Exchanges

There are two methods for transmitting the interaction signals during rural ATS communications with manual telephone exchanges, independently of their location in the rural telephone network: inductive and galvanic.

In the inductive method, for interacting with central battery or local battery manual telephone exchanges via two-way, two-wire junction lines, an inductive RSL complex is used at rural ATS's (depending on the type of rural ATS), while additionally installed at the manual telephone exchange is a head-end complex (VK TsS BRS-M). Head-end complexes, powered from 24 volt batteries, are placed in separate racks with 10 relay boards per rack.

VK TsS VRS-M's are used for local and long distance communications, and can interact with local battery switchboards of any type, with TsB2 and TsB3 switchboards [central battery switchboards], as well as with standard long distance switchboards (M-49, MRU, OU). The joint operation of rural ATS's and manual telephone exchanges using the inductive method does not require making any changes in the equipment circuitry of rural ATS's

The circuit for the communications of a manual telephone exchange with rural ATS's using the inductive method of transmitting the interaction signals is shown in Figure 1.7.



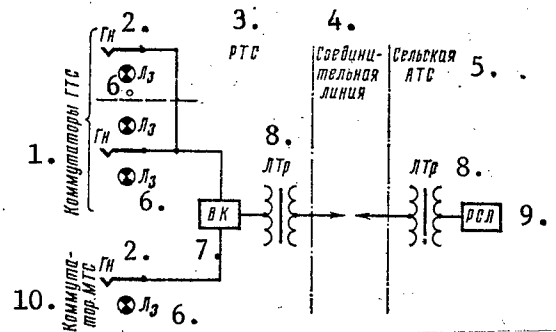

Figure 1.7. Circuit showing manual telephone exchange communications with rural ATS using the inductive transmission method.

Key: 1. City telephone exchange switchboards; 2, Jack; 3. RTS [manual telephone exchange]; 4. Junction line; 5. Rural ATS; 6.  $L_3$  [indicator light 3]; 7. VK [head-end complex]; 8. Line transformer; 9. RSL [connector relay equipment]; 10. Long distance exchange switchboard.

A provision is made for the galvanic method only for the interconnection of rural ATS's with local battery manual telephone exchanges. Depending on the type of ATS, the transmission of signals using direct current is realized either via wires a and b of the junction line (ATS VRS-20M), or via an artificial single wire line, connected to the center taps of the DTN type line transformers (ATS-10/40, UATS-50/100, ATS K-40/80, ATS K-50/200). No provision is made in the ATS-100/500 and 100/500M for galvanic coupling.

Adapting the standard RSL complexes of rural ATS's for galvanic coupling is accomplished by means of resoldering connections provided in the circuits of these devices.

## 1.6. Rural Telephone Exchange Communications with Long Distance Exchanges

### Organizing Communications with the Regional Center Long Distance Exchange

A cord type long distance exchange is provided at each regional center, where the central exchange of the rural telephone network is located. Switched into the intercity switchboards of a regional center long distance exchange are the one-way and two-way long distance telephone channels to the oblast' center long distance exchange, and the direct channels to the long distance exchanges of other regional centers of its own, and in certain other cases, also adjacent oblast's, operating using a toll call order or direct dialing system. Additionally, semi-automatic communications equipment for handling

incoming long distance communications to rural telephone network subscribers, circumventing the operator of the regional center long distance exchange, can be installed at the regional center long distance exchange.

Communications between the regional center long distance exchange and the rural telephone network exchanges is realized through the central exchange of the rural telephone network. For the organization of local (within the limits of a given rural telephone network) and long distance communications over OS - US - TsS and OS - TsS sections, common one-way and two-way interexchange junction line trunk groups are used, which are equipped with universal local and long distance communications instruments. A provision is made on the long exchange - central exchange section for the use of only long distance cord instruments.

At ten step system rural ATS's, which are used as US's and OS's (ATS-100/500, ATS-50/100), special long distance cord instruments (VGM, LIM) are installed for communications from the long distance exchange to the subscribers of these exchanges.

Special long distance cord instruments are not provided at rural crossbar system US's and OS's (ATS K-100/2000, ATS K-50/200, ATS K-40/80), but common switching units (GI, AI [group selector, (?subscriber selector?)]) are used for local and long distance communications, as are universal line complexes which provide the requisite signaling when making long distance connections.

Long distance exchange communications with rural telephone network subscribers is realized via toll call recording trunk and junction lines. Toll call lines are intended for taking call orders from subscribers for long distance conversations, while junction lines serve for establishing incoming and outgoing long distance connections made by regional center long distance exchange operators.

In making the connection to the rural telephone network subscriber, the long distance exchange operator has the ability to:

- Connect into a subscriber line which is busy with a local call and give notice of the long distance call. If the subscriber agrees to break the local connection in favor of the long distance one, he places the telephone receiver on the hook, after which the long distance exchange operator has the ability to send the called subscriber the call ring and make the long distance connection;
- To carry out the preliminary preparation of the subscribers for long distance conversation, and send them the call only at the moment when the connection is made;
- To repeatedly ring when the called subscriber rings off prematurely.

At manually serviced central exchanges, the line and recording trunks are connected into the switchboards in a manner analogous to that for subscriber

lines, and at long distance exchanges, into special line and recording trunk equipment complexes.

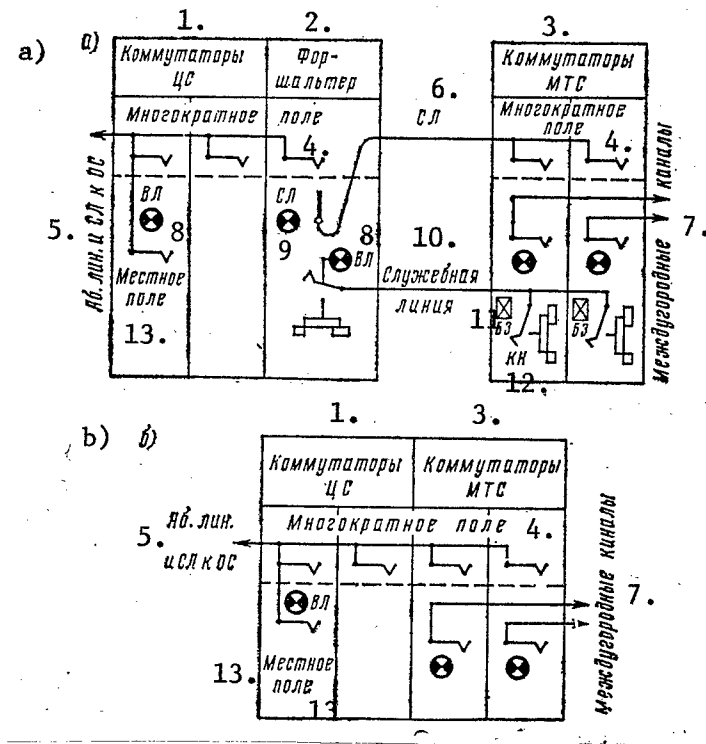

Figure 1.8. Circuit for long distance telephone exchange communications with the central exchange of a manual telephone exchange:

- a) Through the toll switching position;
- b) Via the multiple jack field.

Key: 1. Central exchange switchboards; 2. Toll switching position; 3. Long distance exchange switchboards; 4. Multiple jack field; 5. Subscriber line and junction line to the terminal station; 6. Junction line; 7. Long distance channels; 8. Call light; 9. Signal light; 10. Service line; 11. [?Fuse block?]; 12. KN [expansion unknown]; 13. Local answering jack field.

Long distance connections to the subscribers of a rural telephone network are made via junction lines connected into the central exchange through a toll switching position, or via a common multiple jack field. In the latter case, the long distance exchange should be located in the same building as the central exchange, the capacity of which should not exceed 2,000 numbers. In using standard switchboards (M-49, M-60), the connection of junction lines into the central exchange should be made through the toll switching position.

Circuits for the organization of communications with the regional center long distance exchange through the central exchange for the manual telephone exchange are shown in Figure 1.8.

The line and recording trunks at the ten-step central exchange are switched in as special lines, dialed by the abbreviated number "07" or the three digit number "007" depending on the system of numeration adopted for the rural telephone network and the location of the outgoing exchange in the rural telephone network (the TsS, US or OS).

Shown in Figure 1.9 is the circuit for the organization of communications with the regional center long distance exchange through a central exchange of the ATS-100/500 type. The line and recording trunks are connected into the field of the LI<sub>spets</sub> [special line connector] stage and in ATS's of other types, into the II GI<sub>spets</sub> [II special group selector] (via the II/IV group selector circuit) through the RSL<sub>spets</sub>, which provides for interaction with the line and recording trunk complexes of the long distance exchange (RKZL). The

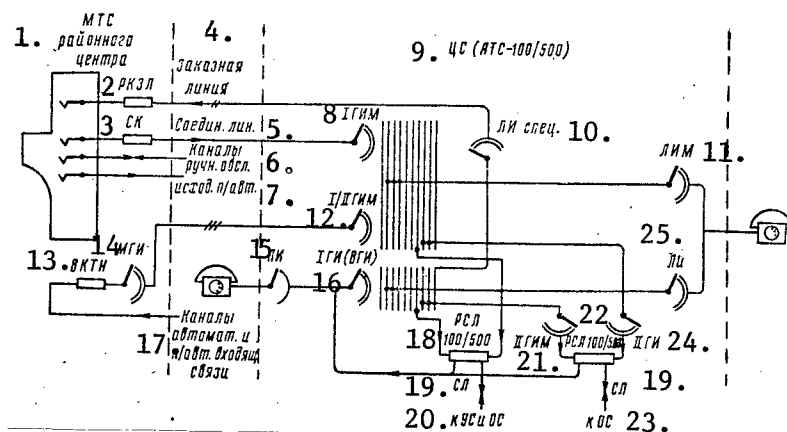

Figure 1.9. Circuit showing the organization of rural telephone network communications with a regional center long distance exchange through a central exchange of the ATS-100/500 type.

Key: 1. Regional center long distance exchange; 2. RKZL [line and recording trunk complex for the long distance exchange]; 3. SK [matching complexes]; 4. Line and recording trunk; 5. Junction line; 6. Manually serviced channels; 7. Outgoing semi-automatic [channel]; 8. I long distance group selector; 9. Central exchange (ATS-100/500); 10. Special line connector; 11. Long distance line connector; 12. I/II long distance group selector; 13. VKTN [channel terminating complexes]; 14. Long distance group selector; 15. Preselector; 16. I group selector (VGI [expansion unknown]); 17. Channels for automatic and semiautomatic incoming communications; 18. RSL 100/500; 19. Junction line; 20. To the junction center and terminal station; 21. II long distance group selector; 22. RSL 100/500; 23. To the terminal station; 24. II group selector; 25. Line connector.

junction lines are connected to the long distance switchboards through matching complexes, SK's. In this case, communications with central exchange subscribers is organized through long distance cable instruments (GIM, LIM [long distance group selector, long distance line connector]), and with junction center and terminal station subscribers, via common long distance connecting line trunk groups of the rural telephone network, which are equipped with universal line complexes. Incoming communications from the long distance exchange to central exchanges of the ATS-47 and ATS-54 types are organized in a similar fashion.

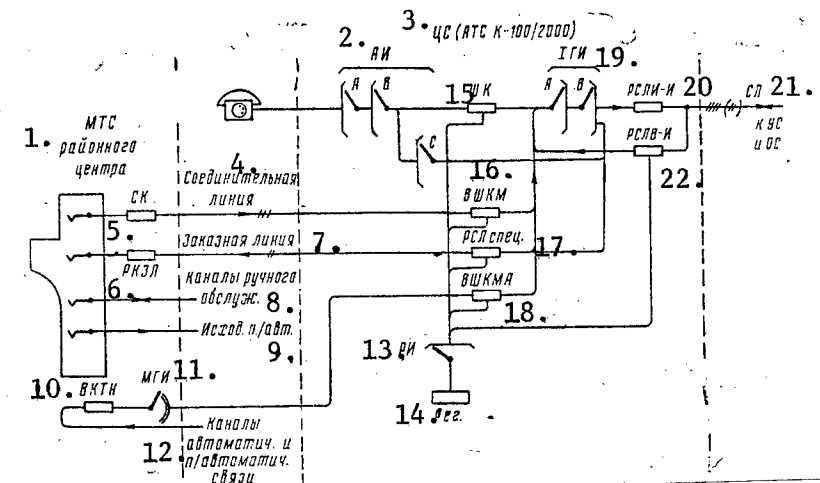

Figure 1.10. Circuit showing the organization of rural telephone network communications with a regional center long distance telephone exchange through a central exchange of the ATS K-100/2000 type.

Key: 1. Long distance telephone exchange of the regional center; 2. AI [subscriber selector?]; 3. Central exchange (ATS K-100/2000); 4. Junction line; 5. Matching complexes; 6. RKZL; 7. Line and recording trunk; 8. Manually serviced channels; 9. Outgoing semi-automatic [channel]; 10. VKTN; 11. MGI [long distance group selector?]; 12. Automatic and semi-automatic communications channels; 13. RI [register finder]; 14. Register; 15. ShK [line cord complex]; 16. VShKM [incoming long distance cord set?]; 17. RSL<sub>spets</sub>; 18. VShKMA [subscriber incoming long distance cord set?]; 19. I GI [I group selector]; 20. RSLI-I [unknown type of outgoing line connector relay complex]; 21. Junction line, to the junction center and terminal station; 22. RSLV-I [unknown type incoming line connector relay complex].

If the regional center long distance telephone exchange has incoming semi-automatic long distance communications channels, the latter are terminated at the long distance exchange by channel complexes (VKTN) and MGI instruments,

in the field of which the junction lines are connected to the central exchange. At the central exchange, these lines are connected to the inputs of the I/II GIM. . .

At crossbar system central exchanges of the ATS K-100/2000 or ATSK types, the line and recording trunks are connected into the field of the I group selector stage through RSL<sub>spets</sub> complexes. The output to these lines is realized by dialing the abbreviated two-digit number "07" or the three digit one, "007", in a manner similar to the case for a ten-step system central exchange.

Shown in Figure 1.10 is the circuit for the organization of communications with a regional center long distance exchange for the case of communications through a central exchange of the ATS K-100/2000 type. The outgoing ends of the junction lines are connected to the long distance exchange switchboard through the SK complex [matching complex], while the incoming ends are connected to the inputs of the I group selector stage through the VShKM complexes. When equipment is present at the long distance exchange for incoming semi-automatic long distance communications from the oblast' center, the junction lines at the long distance exchange of the regional center going to the central exchange are connected into the ten-step system instrument field of the long distance exchange group selector, and at the central exchange, to the inputs of the I group selector stage through the VShKMA.

Junction lines from the long distance exchange switchboards of the regional center are connected into a central exchange of the ATSK type to the inputs of the I/II long distance group selector stage through the connection complexes, the PKP's, which provide for the connection of the lines through the register finder stage to the subscriber registers of the ARB type. At the long distance exchange, the outgoing ends of the junction lines are connected to the switchboards through the SKR matching complexes, which simultaneously perform the functions of the I long distance group selector. Communications with central exchange subscribers is organized through long distance cable instruments (GIM, VShKM), and with the junction center and terminal station subscribers, via the common trunk groups of the long distance junction lines of the rural telephone network.

#### The Organization of Automatic Intra-Oblast' Telephone Communications

Automatic intra-oblast' communications from subscribers of central exchanges of the ATS-54, ATS-54A, ATS-100/500M and ATS K-100/2000 types (with cord complexes which provide for repeating the number dial pulses) are organized by means of AVTS type equipment, which provides a specific group of central exchange subscribers with an output trunk to the oblast' center or to any other point having the same toll rate via direct multiplexed communications channels. For this, the central exchange subscriber first dials the code for output to the AVTS (for example, "8"), and then, having received the second audio signal, dials the complete number of the called subscriber of the oblast' center.



Рис. 1.11. Структурная схема АВТС

Figure 1.11. Structural schematic for AVTS [automatic intra-oblast' telephone communications].

- Key: 1. Regional center; 2. Oblast' center; 3. Central exchange, ATS-54 (or ATS-100/500M); 4. Coin operated telephone; 5. Pre-selector; 6. I GIT [expansion unknown] (or I GI [group selector]); 7. Long distance exchange; 8. Multiplex equipment channels; 9. City telephone exchange; 10. Subscriber equipment complex; 11. Preselector; 12. I group selector; 13. Meter; 14. Pulser unit; 15. Outgoing automatic equipment complex; 16. Incoming automatic equipment complex; 17. I/II GIM [long distance group selector]; 18. II GIM; 19. III GIM; 20. Iv GIM; 21. Line connector; 22. ATS K-100/2000; 23. MA [expansion unknown]; 24. AI [?subscriber selector?]; 25. ShK [cord complex]; 26. Outgoing automatic equipment complex; 27. Incoming automatic equipment complex; 28. Connector relay matching complex; 29. Pulser Unit.

Conversations which have taken place are registered by individual four digit electromagnetic meters. The duration of the conversations is metered by means of repeated counting. At the input end, communications are assured by the long distance flexible cord instruments of the city ATS's of all types. Where AVTS equipment is used, a provision is made for equalizing the ATS equipment circuitry of the regional center (the preselector, the I group selector of ten-step ATS's, the subscriber's line equipment, the flexible cord complex and the I group selector of the ATS K-100/2000), which results from the necessity of organizing conversation metering on subscriber meters, and individually limiting subscriber trunk output to the AVTS, as well as from the capability of using long distance coin operated telephones (MTA's) for communications with the oblast' center.

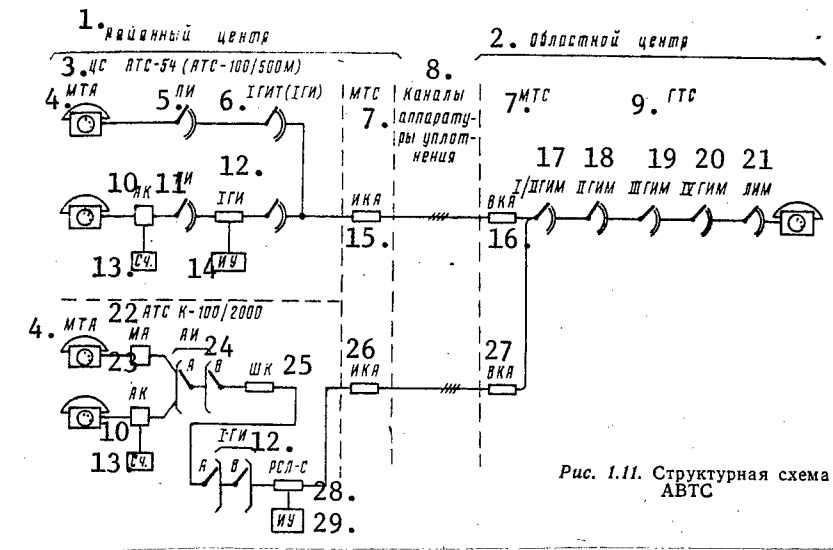
A structural schematic of an AVTS is shown in Figure 1.11. The basic equipment of the AVTS is the incoming and outgoing automatic equipment complex (IKA, VKA). The IKA's [outgoing automatic equipment complexes] are installed at the regional center long distance exchange. At a ten-step system central exchange, they are connected directly into the field of the I group selector, while in a central exchange of the ATS K-100/2000 type, they are connected through matching complexes, RSL-S's. The VKA's [incoming automatic equipment complexes] are installed at oblast' center long distance exchanges, and are connected to the inputs of the I/II long distance group selector. Additionally, included in the AVTS complement are racks for subscriber meters (Sch's) with pulser (IU) boards and RSL-S complexes. These racks are installed at the regional center ATS. When AVTS equipment is used, the trunk output to the trunk line and the internal oblast' networks should be realized through the regional center long distance exchange operator via an individual trunk group of the channels.

A provision is made for the use AVTS equipment only during the transition period, i.e. prior to the organization of automatic long distance communications, in accordance with the principles of zonal communications.

#### The Organization of Communications with a Long Distance Exchange Based on the Principle of Zonal Communications

The internal zonal telephone network takes the form of an aggregate of terminal long distance telephone exchanges, and networks of intrazonal junction lines, which connect the city and rural telephone networks of the zone with the long distance telephone exchanges which are located within the territory of the zone. This communications is organized via the trunk groups of line and recording trunk lines and junction lines which connect the central exchanges of rural telephone networks to the closest (reference) AMTS [automatic long distance telephone exchange] or to the zonal junction (ZU). A uniform seven digit subscriber numbering scheme is employed on the telephone network of the zone.

Each central exchange of the rural telephone network is coupled to the AMTS or ZU of its zone by the independent trunk groups of one-way junction lines; the outgoing zonal and long distance communications, as well as communications with AMTS services (information, toll order desk, etc.) are realized via the line and recording trunk junction lines (zsl), which are equipped with local flexible cord units, while incoming communications to the rural telephone network subscribers is organized via junction lines from the AMTS (or the ZU) to the central exchange, which is equipped with long distance flexible cord units. Thus, in using the principles of zonal communications, the long distance exchanges at regional centers are dismantled.

Used as ATMS's and ZU's are the AMTS-2, AMTS-3, AMTS-4 and ARM-20.

The circuit for rural, zonal and long distance network communications is shown in Figure 1.12. Zonal and long distance communications for rural



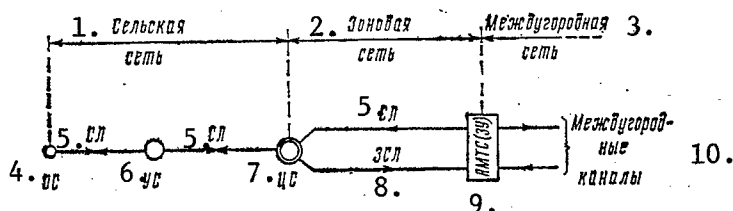

Figure 1.12. Communications circuit for rural, zonal and long distance networks.

- Key: 1. Rural network; 2. Zonal network; 3. Long distance network;  
 4. Terminal station; 5. Junction line; 6. Junction center;  
 7. Central exchange; 8. Recording trunk junction line;  
 9. Automatic long distance exchange (or zonal junction);  
 10. Long distance channels

telephone network subscribers can be realized toll order, direct or high speed operational systems using manual, semi-automatic and automatic means for making the connections. Zonal and long distance connections which have been made are metered by the AMTS telephone operators when making the connection manually or by semi-automatic means, or by the centralized metering equipment installed at the AMTS (or ZU), when the connection is made automatically.

The basic method of determining the category and the number of the telephone of the calling rural telephone subscriber is an automatic one when the automatic method of making intrazonal and long distance connections is used. For this purpose, all ATS's of the rural telephone network are equipped with equipment for automatically determining the category and number of the telephone of the calling subscriber (AON). The AON equipment provides for transmitting a single digit category number and the seven digit zonal number of the telephone of the calling subscriber using a "two of six" multiple frequency code based on the "intervalless packet" method. Information is received from the AON either directly by the AMTS instruments, or by special intermediate equipment installed at the central exchange.

The introduction of AON equipment requires the equalization of the circuitry of a number of existing rural ATS instruments (the preselector, I group selector of the ten step system ATS, the subscriber line equipment complex and the flexible cord complex of crossbar ATS's, as well as junction line complexes of rural telephone networks). In modernizing rural crossbar ATS's, taken into account are the requirements for the organization of automatic zonal and long distance communications using AON equipment.

In rural telephone networks with closed five digit subscriber numeration, the outgoing zonal and long distance communications via the line and recording trunks are established by the terminal station, junction center, and central exchange subscriber by the preliminary dialing of the single digit code "8" and then hearing the additional readiness tone of the AMTS.

When open numeration with an code for the trunk output to the central exchange is used in a rural telephone network, the terminal station and junction center subscribers make outgoing zonal and long distance connections by dialing the two digit code "08". When making an intrazonal connection, the subscriber dials the trunk output code to the zonal network "2", and the seven digit zonal number of the telephone of the called subscriber, and when making a long distance connection, dials the ten digit long distance number, consisting of the three digit zonal code, and the seven digit zonal number of the telephone of the called subscriber. For output to the manual services of the AMTS, the subscriber should dial a two digit number, 11 - 18.

When using AMTS-2 or AMTS-3 type telephone exchanges on the zonal network, installed at the outgoing ends of the recording trunk and junction lines at the central exchange are intermediate registers (PR's), outgoing recording trunk and junction line complexes (IKZSL's) and AON information receive and query units (UZPI's). In this case, after receiving an audio tone from the PR, the calling subscriber of the rural telephone network by directly dialing the number transmits to the PR only the information concerning the number of the telephone of the called subscriber, while the information concerning the category and number of the telephone of the calling subscriber is transmitted from the AON of the outgoing ATS to the UZPI upon its interrogation, and from the latter, to the PR. The information stored in the PR is then transmitted to the AMTS using a "2 of 6" multiple frequency code and the "pulse packet" method. The intermediate equipment provides for the capability of rural network subscriber trunk output via the recording trunk and junction lines to the manual services of the AMTS without interrogation from the AON of the category and number of the telephone of the calling subscriber. In this case, the rural telephone network subscribers can call the toll order desk, or the switchboard operator directly, place a call order for an intrazonal or long distance connection, or obtain it directly.

In the case where AON equipment is lacking at rural telephone network exchanges, and the direct dialing method (NSN) is used for automating zonal and long distance communications, the calling subscriber, using the dial, first transmits to the PR [intermediate register] the three digit zone code (for long distance communications) or the routing code "2" (in the case of intrazonal communications) and the seven digit zonal number of the subscriber being called, and then the proper seven digit zonal number. In this case, a check of the correctness of the dialed proper number by the subscriber is provided via a check loop, established by the PR using the long distance flexible cord instruments. The information accumulated in the PR is transmitted to the AMTS by the method indicated above.

Unversal PR's, which provide for the interaction with AON equipment or direct dialing operation, are used at the central exchanges of rural telephone networks. The use of direct dialing in rural telephone networks is permitted only for the subscribers of the central exchange.

Long distance exchange equipment of the AMTS-4 and ARM-20 types does not require the installation of intermediate equipment on the recording trunk and

The information transmitted by the subscriber and the AON equipment is registered directly at the AMTS. In this case, there is also the possibility of using AON equipment for direct dialing in the rural telephone networks.

A circuit for the organization of communications with a zonal long distance exchange where using ATS-100/500, ATS-47 and ATS-54 ten step system central exchanges is shown in Figure 1.13.

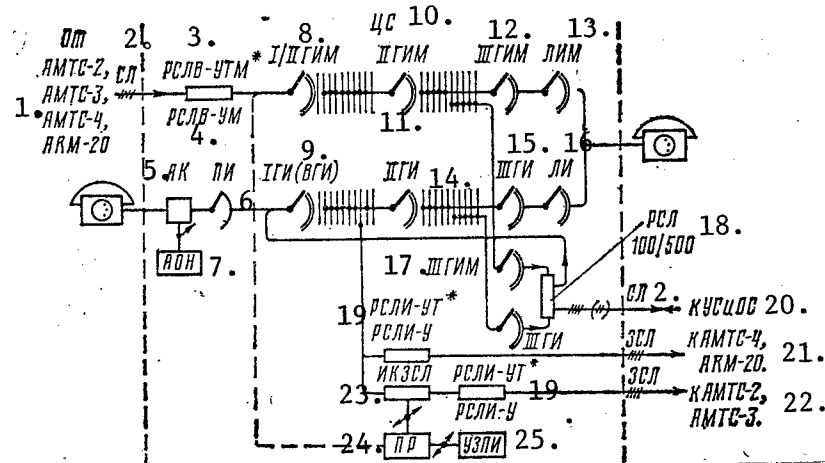

Figure 1.13. Circuit for the organization of rural telephone network communications with a zonal long distance exchange through ten step system central exchanges (ATS-100/500, ATS-47, ATS-54).

- Key: 1. From an AMTS-2, AMTS-3, AMTS-4, ARM-20; 2. Junction line; 3. RSLV-UTM\*; 4. RSLV-UM; 5. Subscriber complex; 6. Preselector; 7. AON [equipment for the automatic determination of the number and category of the calling subscriber telephone]; 8. I/II GIM [long distance group selector]; 9. I GI (VGI) [I group selector (eight decade group selector)]; 10. Central exchange; 11. II GIM; 12. III GIM; 13. LIM [long distance line connector]; 14. II GI; 15. III GI; 16. LI [line connector]; 17. III GIM; 18. RSL 100/500; 19. RSLI-UT\*, RSLI-U; 20. To the junction center and terminal exchange; 21. To the AMTS-4, ARM-20; 22. To the AMTS-2, AMTS-3; 23. IKZSL [outgoing recording trunk and junction line complex]; 24. PR [intermediate register]; 25. UZPI [AON information receive and query unit]; 26. Recording trunk junction line.

\* Those complexes which are under development at the present time are indicated by asterisks.

The line equipment complexes of the recording trunk and junction lines used for communications with the AMTS, the designations of which contain the letter "T", are installed in the multiplex equipment channels where the signal channels are not separated out, while the equipment complexes whose designation does not contain this letter are installed in the KRR type multiplex equipment channels where the signal channels are separated out.\*

The outgoing ends of the recording trunk junction lines are connected into the field of the eighth decades of the I group selector units (VGI). If AMTS-2's or AMTS-3's are used on the zonal network, then intermediate equipment is installed on the recording trunk junction lines and the corresponding line complexes are used (RSLI-UT or RSLI-U).

In the case where direct dialing is used in the rural telephone network, UZPI's are not installed, and to form a monitor loop, each intermediate register is connected to an individual I/II GIM [long distance group selector] for commutating the monitor loop and checking the correctness of the proper number dialed by the subscriber (the circuit for connecting the intermediate register to the I/II GIM is depicted in the schematic by a dashed line).

When AMTS-4's or ARM-20's are used on the zonal network, the outgoing ends of the recording trunk junction lines are formed solely by the line complexes (RSLI-UT or RSLI-U), regardless of whether AON equipment or direct dialing is used in the rural telephone network. In the case of direct dialing, the correctness of the proper number dialed by the subscriber is checked by means of the equipment of the AMTS types cited above, by establishing a monitor loop using the recording trunk and junction lines of the zonal network and the instruments of the long distance cable of the central exchange.

Incoming communications from all four types of AMTS's to the rural telephone network subscribers is accomplished by one method: via the junction lines connected to the inputs of the I/II GIM through the RSLV-UTM or RSLV-UM line complexes. In this case, long distance flexible cord units and universal junction line complexes are used in the rural telephone network.

A circuit showing the organization of rural telephone network communications with a zone long distance exchange where an ATS K-100/2000 is used as the central exchange is shown in Figure 1.14. The outgoing ends of the recording trunk junction lines are connected into the field routing of the I group selector stage dialed by the code "8".

Where AMTS-2 or AMTS-3 equipment is used on the zonal network, the recording trunk junction lines are connected into the field of the I group selector stage through intermediate equipment, and RSLI-UTS or RSLI US line complexes. When direct dialing is employed on the rural telephone network, UZPI's are not used, and each intermediate register is connected through the VShKMA [incoming long distance automatic flexible cord set?] to the register finder,

---

\* [See footnote for Figure 1.13]

and to the input of the I group selector, which provides for forwarding from the intermediate register the series of direct dial pulses of the proper number to the central exchange register, and the subsequent establishing of the monitor loop (the circuits indicated here are depicted in the schematic by a dashed line).

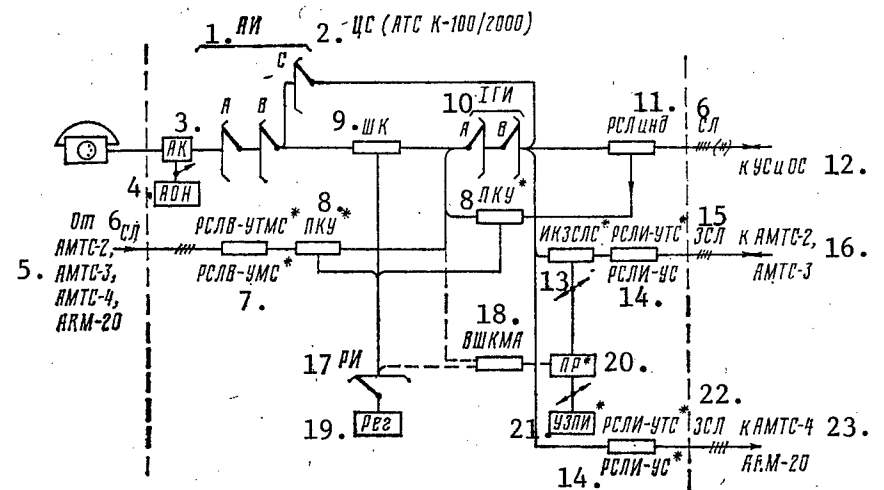

Figure 1.14. Circuit for the organization of rural telephone network communications with zonal long distance exchanges through a central exchange of the ATS K-100/2000 type.

- Key: 1. AI [subscriber selectors]; 2. Central exchange (ATS k-100/2000); 3. Subscriber's line equipment complex; 4. AON; 5. From the AMTS-2, AMTS-3, AMTS-4, ARM-20; 6. Junction line; 7. RSLV-UTMS\*, RSLV-UMS\*; 8. PKU\*[universal connection complex]; 9. ShK [flexible cord complex]; 10. I GI [group selector]; 11. RSLind; 12. To junction center and terminal exchange; 13. IKZSLS\*; 14. RSLI-UTS\*, RSLI-US; 15. Recording trunk junction line; 16. To an AMTS-2, AMTS-3; 17. Register finder; 18. VShKMA; 19. Register; 20. PR\* [intermediate register]; 21. UZPI; 22. Recording trunk junction line; 23. To an AMTS-4, ARM-20.

Where AMTS-4's or ARM-20's are used, the outgoing ends of the recording trunk junction lines are equipped solely with RSLI-UTS or RSLI-US line complexes. Incoming communications from all four types of AMTS's are realized via the junction lines connected through the RSLV-UTMS or RSLV-UMS complexes, which are connected through the universal connection complexes, the PKU's, to the inputs of the I group selector, which provides for an output trunk to the central exchange, junction center and terminal exchange subscribers. The

The PKU complexes, in the case of incoming communications to the central exchange subscribers, perform the functions of a VShKMA, while in the case of a through call, provide for commutating the two and four wire speech channel.

#### Communications with the Long Distance Exchange through a Rural-Suburban Junction

When rural junction centers and terminal exchanges are connected into a SPU [rural-suburban junction], all incoming and outgoing zonal and long distance communications for rural telephone network subscribers are realized through the equipment of this junction.

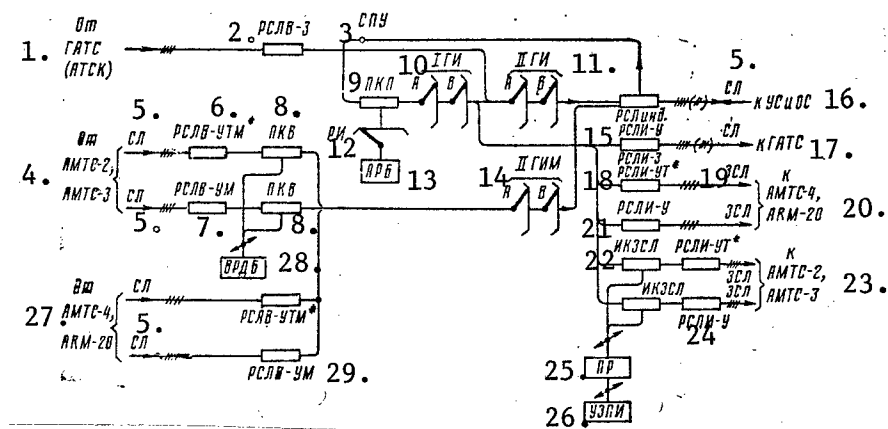

Figure 1.15. The circuit for the organization of rural telephone network communications with zonal long distance exchanges through a rural-suburban junction of the crossbar automatic telephone exchange type.

- Key: 1. From the city telephone exchange (crossbar ATS); 2. RSLV-3; 3. SPU; 4. From the AMTS-2, AMTS-3; 5. Junction lines; 6. RSLV-UTM\*; 7. RSLV-UM; 8. PKV; 9. PKP; 10. I GI; 11. II GI; 12. Register finder; 13. ARB [?Unit subscriber register?]; 14. II long distance group selector; 15. RSLind, RSLI-U; 16. To the junction center and terminal exchange; 17. To the city ATS; 18. RSLI-3, RSLI-UT\*; 19. Recording trunk junction line; 20 To the AMTS-4, ARM-20; 21. RSLI-U; 22. IKZSL; 23. To the AMTS-2, AMTS-3; 24. RSLI-U; 25. PR [intermediate register]; 26. UZPI [AON information receive and query unit]; 27. From the AMTS-4, ARM-20; 28. VRDB; 29. RSLV-UM.

Used as commutating equipment for the SPU are group selector units of the ATSK or ATS K-100/2000 types, which provide for four wire through call connections.

A circuit showing the organization of communications with long distance exchanges based on the principle of zonal communications through crossbar SPU's

of the ATSK type is shown in Figure 1.15. A provision is made at rural telephone network junction centers and terminal exchanges for just the use of AON equipment. Outgoing zonal and long distance communications from junction center and terminal exchange subscribers is realized through the I group selector stage, into the field of which the recording junction lines are connected.

Intermediate equipment is additionally installed on the recording trunk junction lines for communications with AMTS-2's and AMTS-3's.

Incoming communications are realized via junction lines from the AMTS, which are connected to the inputs of the II long distance group selector stage.

To control the process of establishing the incoming connection to the junction center and terminal station, the junction lines from the AMTS-2 and AMTS-3 are equipped with five digit incoming registers of the VRDB type, the connection to which is made through the PKV connection complexes. For communications from AMTS-4's and ARM-20's, it is not necessary to equip the incoming ends of the junction lines with PKV complexes and VRDB registers.

## CHAPTER 3: THE LINE AND CABLE INSTALLATIONS OF RURAL TELEPHONE NETWORKS:

### 3.1. Rural Communications Open Wire Lines

#### Pole Mounted Communications Lines

The pole mounted lines of rural telephone networks (STS's) belong to Class III lines of the all-union VLS [open wire communications lines] classification; the pole mounted lines of rural radio repeater networks (RTS's) when only the cable broadcast circuit is strung, having a working voltage of no more than 360 volts, belong to lines of RTS Class I.

Open wire communications lines suspended on the same support poles as telephone circuits and hard wire broadcast circuits are called *common suspension lines*.

Standard telephone VLS configurations and the number of the circuit positions on the poles are depicted in Figure 3.1, while those for common suspension lines are shown in Figure 3.2. The most widespread ones on the STS's are configurations Nos. 1 and 2. In planning new lines, configurations Nos. 1a, 2a and 3a are used with a spacing between the hooks of 30 cm.

TABLE 3.1. The Main Structural Characteristics of Class III Open Wire Communications Lines and Class I Radio Repeater Network Lines

Тип линии Type of Lines	Обозначение Designation	1. Метеорологические условия				Material and Diameter of the wires, mm	Максимальная допустимая длина пролета, м	Нормальная длина пролета, м
		2. Максимальная скорость ветра при гололеде, м/с	3. Масса воды (гололеда, изморози или мокрого снега), г/пог. м	4. Эквивалентная толщина льда на проводе, мм	5.			
Облегченный Lightweight	О	15	До 150 Up to 150	5	7 8 Биметалл — 4; 3; 2 Сталь — 4; 2 » — 3 » — 2,5 » — 1,5	150 150 125 100 80	100 83,3 83,3 83,3 62,5	
	Н N	15	До 400 Up to 400	10	7 8 Биметалл — 4 » — 3 » — 2 Сталь — 4; 2 » — 3 » — 2,5 » — 1,5	125 100 100 80 62,5 50,3 50	100 100 100 62,5 50,3 50	
Усиленный Strengthened	У	15	До 800 Up to 800	15	7 8 Биметалл — 4 » — 3 » — 2 Сталь — 4; 2 » — 3	100 80 50 50 50	100 80 50 50 50	
	ОУ OU	15	До 1400 Up to 1400	20	7 8 Биметалл — 4 » — 3 Сталь — 4	83,3 60 50 50	83,3 50 50 50	

Key: 1. Meteorological conditions; 2. Maximum wind velocity with ice build-up, m/sec;  
 3. Weight of the water (of the ice crust, hoarfrost, or wet snow), grams/running meter;  
 4. Equivalent maximum thickness of the wall of ice on the wire, mm;  
 5. Maximum permissible span length, m;  
 6. Normal span length, m;  
 7. Bimetal; 8. Steel.



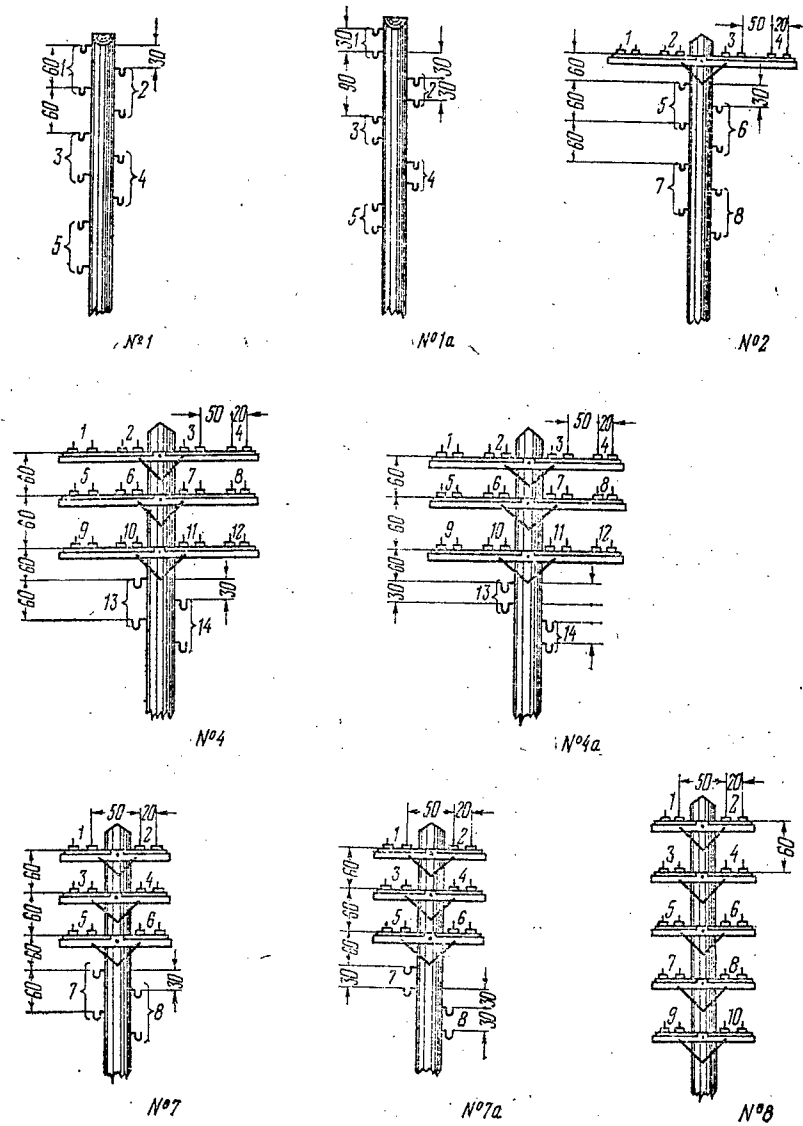

Figure 3.1. Standard open wire communications lines pole configurations.

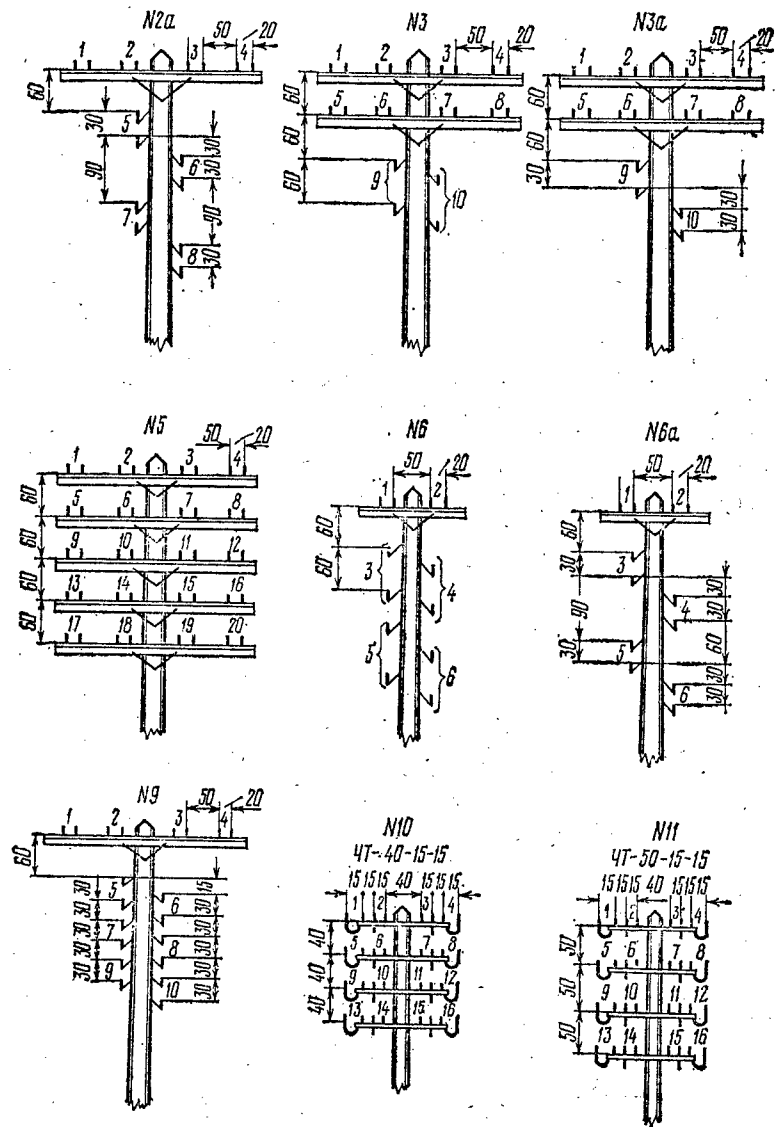

Figure 3.1. [Continued] Standard open wire communications lines pole configurations.

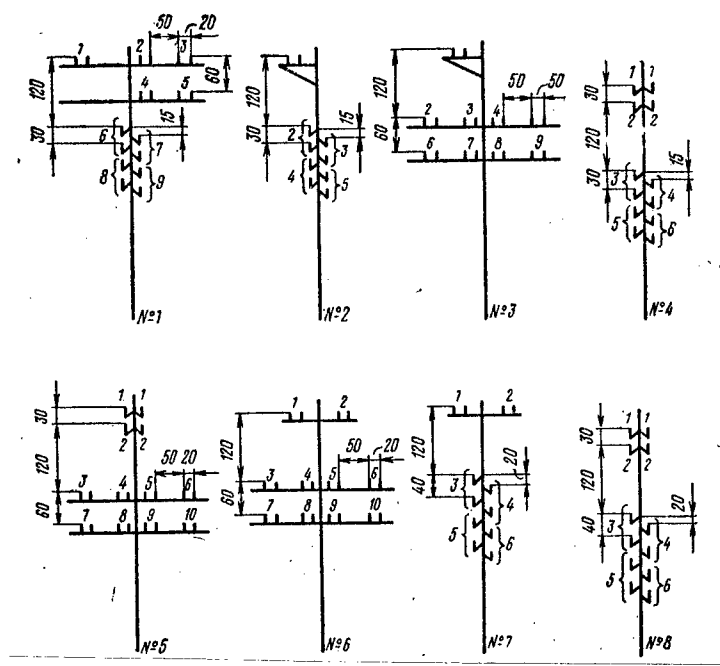

Figure 3.2. Standard support pole configurations for the common suspension of telephone circuit and hard wire broadcast circuit lines.

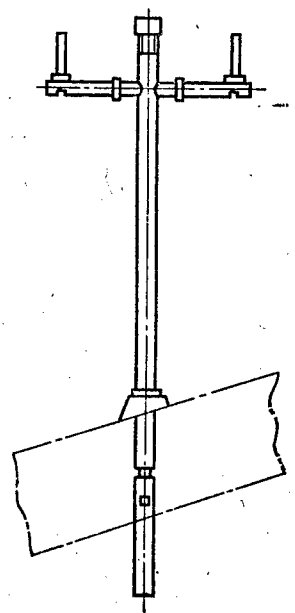

Figure 3.3. Pole construction.

Depending on the meteorological conditions of the regions in which the lines are built, they are broken down into four types: lightweight, standard, reinforced and especially reinforced. Given in Table 3.1. are the basic structural characteristics of Class III open air lines and RTS lines of Class I of different types.

**Pole Supported Communications Lines**

Pole supported lines are usually set up in populated areas. The posts are mounted on the roofs of buildings. Tubular posts of the TST type, fabricated in accordance with GOST 8046-56, are used for the suspension of 1, 2, 6 and 10 pairs of telephone circuits. The structure of

a pole for suspending two circuits is shown in Figure 3.3. Posts for 6 and 10 pairs of circuits can be used for the joint suspension of wires and cables.

The posts are mounted on a cast iron foot and are fastened to the rafter beams of buildings by means of collar clamps. The posts are reinforced by guys, the number of which is determined by the number of suspended pairs of wires, and thus for posts for one, two and six pairs of lines there should be four guys, and for posts for ten pairs, eight guys. Corner, cable and terminal posts are reinforced by an additional guy.

Used for suspension on pole supported lines are steel wires with diameters of 2 and 1.5 mm, and bimetal with diameters of 2 and 1.6 mm. In the case where the telephone lines cross high current lines or for the installation of radio circuits, insulated wires with atmosphere resistant insulation are suspended on the poles.

The wires of pole supported lines are strung on TF-12 type insulators. The length of a span between the poles should, as a rule, be no more than 60 to 80 meters. In exceptional cases, an increase in the span to 150 m is permitted.

LTV wire, which is soldered to the telephone pole line wires, is used for bringing the telephone circuits into attic rooms. The LTV wire is passed through inside the trunk of the post, through the tubular crosspiece and is then brought out through the opening under the corresponding pair of insulators.

To construct radio installation lines, poles are used which are fabricated in accordance with GOST 8715-58. In this case, the following types of poles are used for suspending circuits with a working voltage of up to 240 volts:

- A - Intermediate, with a trunk length of 1.3, 1.6 and 1.9 m;
- B - Intermediate, with removable crosspieces and a trunk length of 1.6 and 1.9 m;
- V - Terminal and corner types, with a trunk length of 1.3, 1.6 and 1.9 m.

To suspend circuits with a working voltage of 360 - 960 volts (clearance, 2.6 m) and for the joint suspension of circuits with a working voltage of 120 - 240 volts along with circuits having a voltage of 360 - 960 volts, the following types of posts are used:

- G - Intermediate, with a trunk length of 3.6, 3.9 and 4.2 m;
- D - With a trunk length of 3.6 m.

The feed-in from the pole feeder line goes through the subscriber transformer, which can be mounted on the pole, in the attic or a stairwell. Used as the feed-in wire is PTPZh or PRZh wire. It is fed into the trunk of the post through a T-shaped porcelain cone insulator. The feed-in wire is connected to the line terminals, or, as an exception, soldered to the wire.

## Wires

Steel wire line with diameters of 3 and 4 mm is employed on open air STS lines for interexchange communications; wire with diameters of 1.5, 2.0, 2.5, 3.0 and 4.0 mm is used on subscriber lines, and in certain cases, bimetal wire line with diameters of 2, 3 and 4 mm, or copper wire with diameters of 3 and 4 mm is used for interexchange communications.

The basic mechanical and electrical characteristics of the wire are given in Table 3.2.

Binding wire is used to fasten the wires to the insulators. The basic data for the binding wire when using a particular wire line are given in Table 3.3.

Small diameter steel and bimetal wires (1.5 - 2 mm) are joined together by double splicing.

## Insulators and Fittings

Porcelain (TF) and glass (TSB) insulators, manufactured from special glass, which do not leach out, are used on the open wire lines of STS's. A cross section of an insulator is shown in Figure 3.4, and given in Table 3.4 are the purpose and basic characteristics of the line insulators.

Spindle, branching insulators with three collars can also be used on Class III communications lines and radio repeater network lines: porcelain, ShO-16 and ShO-12; and glass, ShOS-16 and ShOS-12. Feed-in insulators can be used for bringing in the wires: VB with a height of 132 mm and a diameter of 92 mm at the lower section; and VM with a height of 103 mm and a diameter of 70 mm. RFO-12 and RFO-10 (radio repeater, porcelain, branching types) can be used for subscriber feed-in units.

Included among the fittings of open wire communications lines are the cross-bars, steel spindles and hooks, extension fishplates and clamping terminals, brackets, support hooks, T-shaped brackets and extensions for wire transposition (Figure 3.5), as well as fastening parts (struts, bolts, nuts, washers, lag screws and clamps).

The crossarms are made from hardwoods (oak, pine), which are impregnated with preservatives, or are made of angle steel. Given in Table 3.5 are the basic dimensions and weights of wooden and steel crossarms. The crossarms are fastened to the support with bolts and two steel struts, which are secured to the support pole with a lag screw. On ferrocement poles, the crossarms are fastened with steel collars.

The basic dimensions and weights of the spindles for wooden and steel crossarms are given in Table 3.6, and those for the hooks, in Table 3.7.

TABLE 3.2. Basic Mechanical and Electrical Characteristics of Line Wire

Material	Diameter Диаметр мм	1. Относительное удлинение, не менее, %	2. Предел про- ности, не ме- нее, кг/мм <sup>2</sup>	3. Число переги- бов на 180° не менее	4. Сопротивление по- стоянному току при 20°C, не более, Ом/км	5. Масса прово- локи, кг/км
Сталь (ГОСТ 1668-46)	4,0	10	37	8 (10 <sup>1</sup> )	11,61/10,98*	100
Steel (GOST 1668-46)	3,0	10	37	11 (10)	20,65/19,52	56
	2,5	10	37	—	29,74/28,11	39
	2,0	—	65	8 (5)	46,47/43,92	25
Медь (ГОСТ 6011-51) Copper (GOST 6011-51)	4,0	1,2	42	6,5 (20)	1,49	113
	3,0	1,2	43	8,5 (10)	2,65	64
Bimetal BSM-2 Виметалл — ВСМ-2 (сталеледь) (GOST (ГОСТ 3822-61) 3822-61) Copper clad steel	4,0	1,5	75	8 (10)	5,0	106
	3,0	1,5	75	8 (10)	9,0	59
	2,0	1,5	75	10 (10)	20,0	26
Copper clad steel	1,5	1,5	75	12 (10)	32,0	15

- 1) Indicated in parentheses is the radius of the vice jaws, in mm.  
 2) In the numerator, for copper bearing steel, and in the denominator, for the usual steel wire.  
 Note: When crossing rivers and in other cases where increased line wire strength is necessary, bronze antenna wire of the PAB type with diameters of 4.7 and 7.4 mm is used, which has an ultimate strength of 72 - 75 Kg/mm<sup>2</sup>.

Key: 1. Relative elongation, no less than, %; 2. Ultimate strength, no less than, Kg/mm<sup>2</sup>;  
 3. Number of reverse bends through 180°, no less than; 4. DC resistance at 20° C, no more than, Ohms/km; 5. Weight of the wire, Kg/km.

TABLE 3.3 Basic Characteristics of Binding Wire

Line Wire		Binding Wire				
Material	Diameter	Material	Diameter	Tensile Strength, No Less Than, Kg/mm <sup>2</sup>	Number of Reverse Bends Through 180°	Approximate Consumption Per Km, Kg/Km
Steel	4.0	Steel	2.5	-	13	0.8
	3.0		2.0	-	15	0.5
	2.5; 2 and 1.5		1.2	-	17	0.2
Copper	4.0 and 3.0	Soft Copper, MM	2.5	21	-	1.0
Bimetal or Copper	4.0	Bimetal	2.5	-	-	0.8
	3.0		2.0	-	-	0.5
	2.0		1.2	-	-	0.2

Figure 3.4. Section through an insulator.

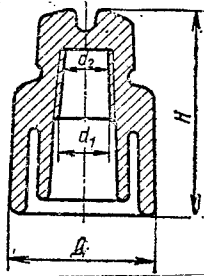

Support Poles

Either wooden or steel reinforced concrete posts, sometimes in wooden or concrete extensions, are used as support poles (Figure 3.6) on rural communications and radio installation lines.

Intermediate wooden support poles, held by support pole braces, which are placed to the perpendicular to the line, are called storm guyed, and those placed in line with the lines, are called reinforced. These support poles are set up when the conductors is six or more in regions without freezing weather where the wind velocity can be 30 m/sec or more, and in freeze regions for type N, U and OU lines for any wind velocity. The storm guyed support pole is secured by one pole brace with an underground stay block. The pole braces are set up in an alternating fashion, first on one side and then on the other side of the line. A reinforced pole, where the wires are placed on hooks, is secured by two pole braces or guys. On O and N type lines, the storm guyed and reinforced poles are set up in an alternating fashion, every other 1.5 Km, for type U, every other 1 Km, and for type OU, every other 0.5 Km.

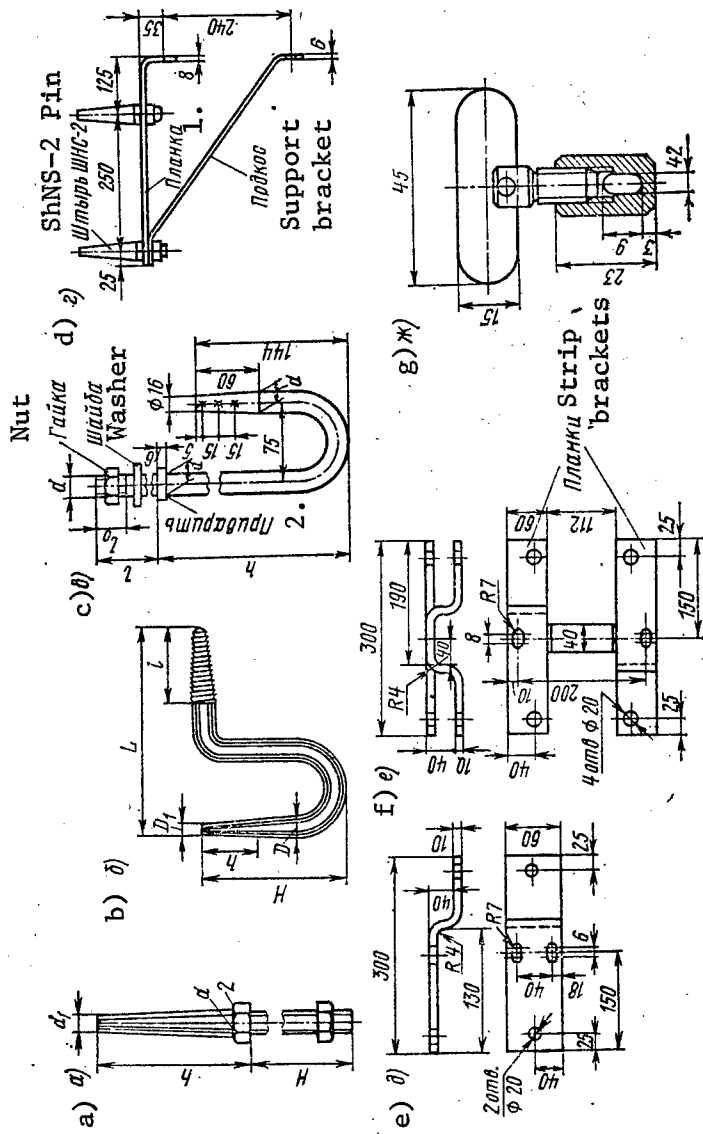

Figure 3.5. Open wire communications lines fittings:

Key: a) Spindle; b) hook; c) Support hook; d)  $\Gamma$ -shaped bracket; e) Type NSD extension splice; f) the same, type ND; g) Check clamp connector.  
 1. Bracket strap; 2. To weld onto.



TABLE 3.4. The Basic Characteristics and Function of the Line Insulators

Type of Insulator	Назначение Function	Height H, mm.	Наружный диаметр нижней части D, мм	Внутренний диаметр 2. отверстия, мм 3. в нижней части 4. в верхней части	Weight Масса кг	Электрическое сопротивление изоляции, не менее МОм	Величина усилия на срез головки, кг
ТФ-12 TF-12 ТСБ-4 TSB-4	Для стальных проводов Ø 2,5 и 3 мм, медных и биметаллических Ø 1,6 - 2,5 мм 7.	67	49	16 15	0,20 0,18	20000 1000	300
ТФ-16 TF-16 ТСБ-3 TSB-3	Для стальных проводов Ø 3 и 4 мм, медных и биметаллических Ø 3 и 3,5 мм 8.	86	61	20 18	0,35 0,3	40000 4000	600
ТФ-20 TF-20 ТСБ-2 TSB-2	Для медных и биметаллических проводов Ø 4 мм 9.	108	75	22 20	0,62 0,58	50000 5000	800

Key: 1. Outside diameter of the lower part, D, mm; 2. Inside diameter of the opening, mm; 3. In the lower part; 4. In the upper part; 5. Electrical insulation resistance, no less than MΩ; 6. Magnitude of the force to shear off the head, Kg; 7. For steel conductors with diameters of 2.5 and 3 mm, copper and bimetal conductors with diameters of 1.6 - 2.5 mm; 8. For steel conductors with diameters of 3 and 4 mm, copper and bimetal conductors with diameters of 3 and 3.5 mm; 9. For copper and bimetal conductors with a diameter of 4 mm.

TABLE 3.5. Basic Dimensions and Weights of Crossarms

Type of Crossarm	Shape and Cross Sectional Dimensions, mm	Total Length, mm	Spacing, mm		Crossarm Weight, Kg.
			Between the Conductors of One Circuit	Between the End Conductors of Adjacent Circuits	
Telephone type, 8 spindle, wooden	Rectangular, 100 x 80	2,500	200	500	-
The same, 4 spindle	Rectangular, 100 x 80		200	500	-
Telephone type, 8 spindle, steel for type O and N lines	Angle, 50 x 50 x 6	2,400	200	500	10.75
The same, for type U and OU lines	Angle, 60 x 60 x 6	2,400	200	500	13.1
The same, 4 spindle for type O and N lines	Angle, 40 x 40 x 4	1,000	200	500	2.45
The same, for type U and OU lines	Angle, 50 x 50 x 6	1,000	200	500	4.5

Feed-in support poles are secured by a pole brace on the side of the wire pull, where the number of wires is more than 16, they are doubled (using two) and are equipped with dual crossarms with feed-in insulators.

Cable support poles, when the number of wires is no greater than 16, are made as standard poles and are equipped with double crossarms, a cable box, a cable platform and a ground. When the number of wires is greater than 16, a twin or half-anchored support pole is used.

The cable boxes employed are of the YaKM long distance type with a capacity of 4, 6, 8 and 10 quads (8, 12, 16 and 20 circuits).

Type YaKG city [cable] boxes, having capacities of 10 and 20 circuits, are used on interexchange communications lines with nonmultiplexed circuits, as well as on subscriber lines.

When the wires are suspended on hooks, inspection poles are equipped with three collar ShO insulators, or a doubled number of hooks with insulators, and when the wires are suspended on crossarms, they are equipped with inspection extensions with spindles and insulators. A ground consisting of a steel wire is set up for inspection poles, and the poles are provided with steel

TABLE 3.6. Basic Dimensions and Weights of the Spindles

Type of Spindle	Function	Overall length, mm	Length, mm			Diameter, mm		Weight, Kg
			Of the lower part	Of the upper conical part	Thread of the lower part	Of the upper part	Of the lower part	
ShT-4D	For wooden cross-arms and TF-12 and TSB-4 insulators	190	110	80	M-12	12	12	0.29
ShT-4S	The same, for steel crossarms	100	20	80	M-12	12	12	0.13
ShT-3D	For wooden cross-arms and TS-16 and TSB-3 insulators	220	120	100	M-16	15	16	0.38
ShT-3S	The same, for steel crossarms	120	20	100	M-16	15	16	0.29
ShT-2D	For wooden cross-arms and TF-20 and TSB-2 insulators	240	120	120	M-16	16	19	0.46
ShT-2S	The same, for steel crossarms	140	20	120	M-16	16	19	0.32
ShNK-2	For inspection extensions and bracket supports with TF-20 and TSB-2 insulators	155	35	120	M-22	16	25	0.51
ShNS-2	For I-shaped support brackets and extension plates for wire transition and transition supports.	155	35	120	M-18	16	23	0.40

climbing rungs. These support poles are usually set up at distances of 20 to 50 Km, depending on local conditions.

Transition support poles are made as semi-anchored poles, consisting of two pole beams with a spacing of 1,500 mm between their centers, and are fastened together above the ground by a cross stay, and below the ground by a cross beam.

TABLE 3.7. Basic Dimensions and Weights of the Hooks

Type of Hook	Function	Maximum diameter of the hook, mm	Height of hooked part	Overall length, mm	Minimum diameter or dimension of spindle part, mm	Length of screw thread part, mm	Weight, Kg
KN-12	For TF-12, TSB-4, Sh0-12, ShOS-12 and RF-12 insulators	12	80	130	12	53	0.21
KN-16	For TF-16, TSB-3, Sh0-16 ShOS-16 insulators	16	110	170	16	70	0.50
KN-18	For TF-20, TF-16, TSB-2 and TSB-3 insulators	18	150	210	16	80	0.85
KN-20	For TF-20 and TSB-2 insulators on corner and terminal support poles	20	150	210	16	80	1.05
KPD-16	Hanging type for wooden crossarms and TF-16 and TSB-3 insulators	16	144	335	M-16	40	0.84
KPS-16	The same, for steel crossarms	16	144	290	M-16	17	0.78
KPD-18	The same, for wooden crossarms and TF-20 and TSB-2 insulators	18	144	337	M-18	40	1.06
KPS-18	The same, for steel crossarms	18	144	292	M-18	17	0.97
KR-10	For RF-10 insulators	10	58	95	10	40	0.125

Pine, oak and larch poles are used for making the wooden support poles, since they are the most resistant to decay. Given in Table 3.8 are the dimensions of poles for support poles and the beams for extensions, used for open wire communications lines supports.

The wooden telephone poles are impregnated with preservatives. The most widespread field method (simplified) of impregnating pine, spruce, cedar and fir poles is the wrapping method. The preservative is applied in the form of a paste to the part of the pole below the ground (buried) while it is placed on the surface of the ground. Thereafter, a wrapping of roofing felt, ruberoid [a roofing material] or water resistant paper, coated with a water repellent (asphalt or an asphalt emulsion), and the edge of the wrapping is bound to the pole with steel wire. The surface of the wrapping and the part of the log 3 cm above and below the wrapping are coated with waterproofing: Type B bituminous varnish or a solution of asphalt in kerosene. After setting the pole up,

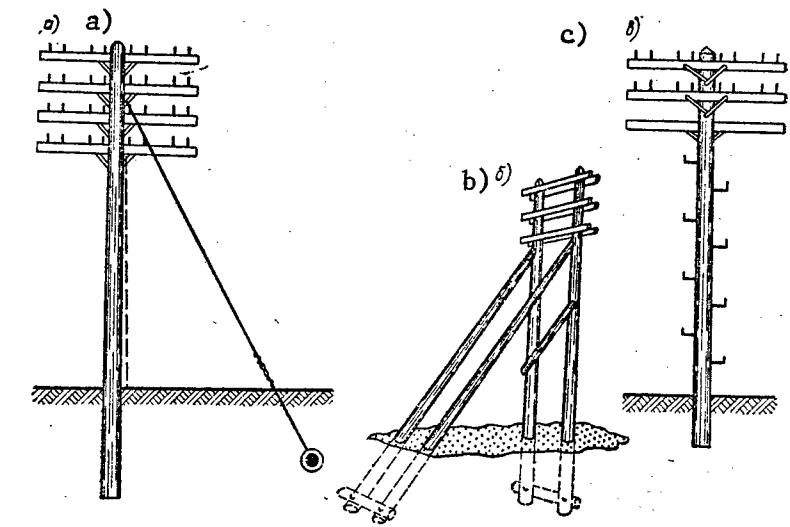

Figure 3.6. Types of wooden support poles:  
 a) Corner pole with guys; b) Semi-anchored type;  
 c) Inspection type.

TABLE 3.8. Dimensions of Lumber Materials for Open Wire Communications Lines Support Poles

Назначение бревен 1.	Диаметр в вершине, см 2.	Длина, м Length, m
Для опор For the supports	14—24 18—24	5,0; 5,5; 6,0; 6,5; 7,5; 8,5 и 9,5 11 и 13
Для приставок For the extensions	14—24	2,75; 3,25 и 3,5

Key: 1. Function of the timbers; 2. Diameter at the top, cm.

the wrapping should protrude 10 cm above the surface of the ground. If it is necessary to protect the entire underground part of the pole against decay, then two wrappings of 60 cm each are applied, and a circular sole plate is applied to the end face of the pole.

The compositions of preservative pastes and their consumption for one wrapping are given in Table 3.9.

The timely impregnation of the support poles, with a moisture content of 20 - 30 % is carried out using factory methods. The Ruping method: the impregnation is carried out in hermetically sealed metal cylinders, where the preservative (a mixture of creosote and crude oil) fills in the pores of the wood under pressure. The hot-cold bath method: the logs are immersed by their butt ends for three hours in hot (90 - 95° C) preservative (creosote), and then the

TABLE 3.9. Compositions of Preservative Pastes and their Consumption for one Wrapping

1. Наименование пасты	2. Состав, %, по весу						9. Расход пасты на один бандаж при длине окружности опоры 100 см, г
	3. фтористый натрий	4. битум	5. керосин	6. каменноуголь- ный лак «Б»	7. экстракт сульфитных щелоков	8. вода	
10. Битумная	55	20	25	—	—	—	1360
11. На каменноугольном лаке	55	—	—	35	—	10	1360
12. На экстракте сульфитных щелоков	62	—	—	—	12	26	1200

Key: 1. Type of paste; 2. Composition in percent by weight; 3. Sodium fluoride; 4. Asphalt; 5. Kerosene; 6. "B" bituminous varnish; 7. An extract of sulfite waste liquors; 8. Water; 9. Paste consumption per one wrapping with a peripheral length around the pole of 100 cm, in grams; 10. Bituminous; 11. Based on bituminous varnish; 12. Based on the extract of sulfite waste liquors.

temperature of the preservative is reduced to 40 - 45° C. In this case, a vacuum is formed in the pores of the lumber and they are filled with preservative. Prolonged soaking (10 days) is carried out in baths with an aqueous solution of uralite or sodium fluoride.

The overall height of the support pole, H, is defined as the sum of the height of the part above ground:

$$H_o = b + c(n - 1) + f + h_{\text{clearance}} \quad (3.1)$$

and the height of the buried part of the support pole,  $h_{\text{bur}}$ :

$$H = H_o + h_{\text{bur}} \quad (3.2)$$

where b is the distance from the top of the support pole to the center of the upper crossarm or to the upper hook, in m;

c is the distance between the crossarms or the hooks, m;

n is the number of crossarms or the maximum number of hooks placed on one side of the support pole;

f is the amount of sag of the conductor at the highest temperature based on Table 3.10, cm;

$h_{\text{clear}}$  is the line clearance determined from Table 3.11, m.

The depth to which the support poles are sunk depends on the number of wires suspended, the overall length of the support pole and the soil classification (Table 3.12).

TABLE 3.10. Amount of Sag for Steel and Bimetal Conductors

1. Длина пролета, м	2. Стрелы провеса, см, при температуре воздуха, °C								
	-40	-30	-20	-10	0	+10	+20	+30	+40
3. Провода диаметром 2,5-5,0 мм									
40	10	11,5	14	17	21	26,5	32	38	44
50	15,5	18	21,5	25,5	31	37	44	51	57
62,5	24	27,5	33	38	45	53	60	69	77
83,3	42	48	56	63	73	82	92	102	110
100	61	69	78	88	98	110	120	132	142
4. Провода диаметром 1,5-2,0 мм									
40	8	9	11	12	14	17	20	25	30
50	14	15	17	19	22	26	31	37	43
62,5	21	23	27	30	35	39	47	55	63
83,3	41	43	47	53	60	68	78	89	100

Key: 1. Span length, m; 2. Amount of sag, cm, at an air temperature of, ° C; 3. Conductors with diameters of 2.5 - 5.0 mm; 4. Conductors with diameters of 1.5 - 2.0 mm.

TABLE 3.11. Clearances of Open Wire Communications and Radio Network Lines

Clearance	Magnitude, in m, for the communications line
Distance from the ground to the lower conductor for lines running along railroad tracks, outside of populated areas	2.5
The same, for lines running along highways, outside of populated areas	3.0
The distance between the lower conductor of one, and the upper conductor of another communications line, at their intersection, for the lowest and the highest temperatures	0.6
Distance between the lower conductor of the line and the rail head when the line crosses a railroad bed for normal and narrow gauge track	7.5
Distance between the lower conductor of a line and the cable carrying the contact conductor of an electrified railroad	2.0
Distance from the ground to the lower conductor of a line when crossing highways	5.5
Distance from the line support poles to the head of the closest rail when the line is run along a railroad bed	1.3 times the height of the part of the pole above ground

TABLE 3.11. [Continued] Clearances of Open Wire Communications and Radio Network Lines

Clearance	Magnitude, in m, for the communications line
Distance between the lower conductor of a feeder RT [radio repeater] circuit, and the upper wire of a communications line, as well as when radio repeater network lines cross each other	1.25
The distance between the axes of the support poles of communications lines running parallel to each other in the presence of only long distance circuits and a nonferrous metal circuit multiplexed with three or twelve channel equipment	8.5
Horizontal spacing between the conductor closest to a building and the vertical plane passing through the edge of a cornice or some other protruding part of the structure	2.25
The distance from the highest masts of ships passing along a set water route at maximum high water to the lowest conductor of a line when it crosses rivers and channels	1.0

TABLE 3.12. Soil Classification

Soil Classification	Soil Designation	Characteristics
I	Soft	Sand, friable vegetative soil, chernozem, peat, light loams
II	Firm or Marshy	Quicksand, packed vegetative soil, peat with the roots of bushes, gravel, sand and vegetative soil with crushed gravel or pebbles, pure fertile clay
III	Stony	Heavy friable clay, shale and schistous clays, chalky rock, soft sandstone, sectional rock.
IV	Rocky	Hard sandstones and limestones, continuous rock, quartz rock.

The height of the above ground part,  $H_0$ , is first determined from expression (3.1), and then the approximate depth is found from Tables 3.13 and 3.14, and the overall length is specified more precisely from Table 3.8 as applied to the set dimensions, or the need to set up supports in extensions or supports made up of two timbers is established.



TABLE 3.13. Depths to which Reinforced Concrete and Wooden Support Poles are Set In for Class III Communications and Radio Repeater Network Lines

1. Число проводов	2. Глубина ям, м, для категорий грунта						
	II и III			II and III		IV	
	3. при длине опоры, м						
	6,5	7,5	8,5	9-11	6,5	7,5-8,5	
Up to 6	До 6	1,2	1,3	1,4	1,5	0,9	1,1
Up to 12	До 12	1,2	1,3	1,4	1,5	0,9	1,1
Up to 24	До 24	1,4	1,4	1,5	1,6	0,9	1,1
Up to 40	До 40	—	1,6	1,6	1,7	—	1,1

Footnote: In Category I soils, and on the slopes of hills with a slope greater than 45°, the holes are dug out 0.15 m or more additionally.

Key: 1. Number of conductors; 2. Depth of the holes, for the following soil classifications; 3. For a support pole length of, in m.

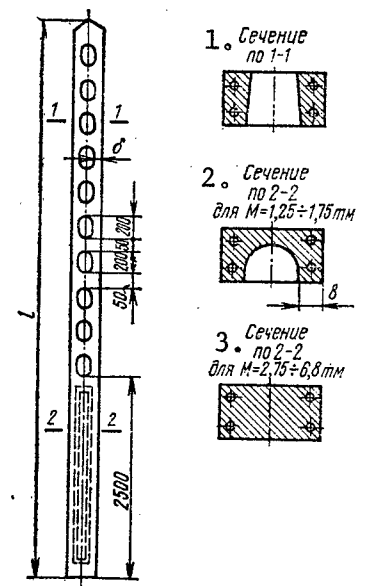

Figure 3.7. Ferrocement pole of the PO type.

Key: 1. Section through 1-1;  
2. Section through 2-2, for  $M = 1.25 - 1.75 \text{ t}\cdot\text{m}$ ;  
3. Section through 2-2, for  $M = 2.75 - 6.8 \text{ t}\cdot\text{m}$ .

Given in Table 3.15, by way of example, are the basic dimensions of wooden support poles for the most widely disseminated size of 3.0 m.

Ferrocement support poles and extensions are made rectangular in the following types (Figure 3.7):

- PO: lightweight support pole with unstressed reinforcing steel;
- PON: lightweight support pole with prestressed reinforcing steel;
- PR: rectangular attachment with unstressed reinforcing steel.

The PO and PON support poles, and PR extensions, are designated in terms of their design bending moment (for example, PO-1.75: bending moment, 1.75 ton·m).

Indicated in Table 3.16 are the dimensions of ferrocement support poles, and in Table 3.17, the height and design bending moments of the support poles (for the 3.0 m size), and in Table 3.18, the dimensions of the extensions.

TABLE 3.14. Depth to Which Transition Support Poles are Set In

1. Число проводов	Общая высота опор, м 2.	Высота опор от дорожного полотна, м 3.	Реличина заглубления опор, м 4.
До 8 Up to 8	12,8	11	1,8
До 16 Up to 16	13,5	11,6	1,9
До 24 Up to 24	14,5	12,5	2,0
До 32 Up to 32	15,0	13,0	2,0

Key: 1. Number of conductors; 2. Overall support pole height, m; 3. Support pole height from the road bed, m; 4. Depth to which the support poles are set in, m.

TABLE 3.15. Dimensions of Wooden Support Poles (for a clearance of 3.0 m)

Число проводов 1.	Профиль опоры 2.	Общая длина опоры, м 3.	Минимальный диаметр опор в вершине, см, для линии типа 4.			
			О О	Н N	У U	OU
4	1 и 8	6,5	12	12	12	13
8	1 и 8	7,5	12	14	14	15
12	5	8,5	12	14	16	19
16	2 и 6	8,5	14	17	18	20
20	3 и 7	7,5 и 8,5	15	18	19	21
24	4	6,5	16	18	19	22

Key: 1. Number of conductors; 2. Support pole configuration; 3. Overall length of the support pole, m; 4. Minimum support pole diameter at the top, cm, for a line of the type:.

TABLE 3.16. Dimensions of Ferrocement Support Poles

Type of Support Poles Тип опор	Расчетный изгибающий момент, т·м 1.	Высота опоры м 2.	Поперечное сечение, см <sup>2</sup> 3.	Масса, кг 4.
PO-1.75 ПО-1,75	1,75	6,5	24×14	343
PON-1.75 ПОН-1,75		7,5		390
PO-2.75 ПО-2,75	2,75	6,5	24×14	410
PON-2.75 ПОН-2,75		7,5		455
PO-4.4 ПО-4,4	4,4	7,5	30×18	725
PON-4.4 ПОН-4,4		8,5		810
PO-6.8 ПО-6,8	6,8	7,5	30×18	725
PON-6.8 ПОН-6,8		8,5		810

Key: 1. Design bending moment, t·m; 2. Height of the support pole, m; 3. Cross section, cm<sup>2</sup>; 4. Weight, Kg.

TABLE 3.17. The Height and Design Bending Moments of Ferrocement Support Poles (for a clearance of 3.0 m)

Число проводов Number of Wires	1. Длина пролета, м						
	50		62,5		83,3		
	2. для линий типа						
	О О	Н Н	У У	ОУ ОУ	О О	НН	О
До 8 (вкл.) Up to 8 (inclusive)	6,75 1,75			6,5 1,75		6,5 1,75	
До 16 (вкл.) Up to 16 (inc.)	6,5 1,75	6,5 2,75	6,5 4,4	6,5 1,75	6,5 2,75	—	
До 24 (вкл.) Up to 24 (inc.)	6,5 1,75	6,5 2,75	6,5 4,4	7,5 6,8	7,5 2,75	7,5 4,4	—

Footnote: The length is given in the numerator; and in the denominator, the design bending moment of the support pole.

Key: 1. Span length, m; 2. For the following types of lines.

TABLE 3.18. Types and Dimensions of Ferrocement Extensions

Тип приставок 1.	2. Расчетный изгибающий момент, т·м, приставок				Поперечное сечение, см <sup>2</sup> 7.	Длина приставки м 8.	Масса приставки кг 9.
	3. поперек линии		4. вдоль линии				
	5. одной	6. двух	5. одной	6. двух			
PR-0.6 ПР-0,6	0,65	1,75	0,42	0,84	14×15	2,8 и 3	148 & 159
PR-0.8 ПР-0,8	0,80	2,75	0,57	1,14	14×17	3 и 3,2	179 и 190
PR-1.2 ПР-1,2	1,2	4,4	0,61	1,22	14×20	3 и 3,2	210 и 224
PR-2.0 ПР-2,0	2,0	6,8	1,0	2,0	14×20	3,2 и 3,5	165 и 175

Key: 1. Type of extension; 2. Design bending moment, in t·m, of the extension; 3. Perpendicular to the line; 4. Along the line; 5. Of one; 6. Of two; 7. Cross section, cm<sup>2</sup>; 8. Length of the extension, m; 9. Weight of the extension, Kg.

The height of ferrocement or wooden extensions for wooden support poles is determined as a function of the depth to which these support poles are dug in, and amounts to 2.8 m for a hole depth of 1.1 - 1.3 m, 3 m for a hole depth of 1.4 - 1.5 m, and 3.2 m for a hole depth of 1.6 - 1.7 m.

The support poles are secured in the extensions by means of two clamps of steel wire with a diameter of 4 mm. The distance between the clamps is 100 cm, and the overall length of the coupling of the extension to the support pole is 135 cm. The support pole should be set off from the surface of the ground by 30 - 35 cm. The number of turns in the clamp is specified in Table 3.19.

TABLE 3.19. The Number of Turns of Steel, 4 mm Wire in Collar Clamps for Securing Support Poles to Extensions

Тип линии Type of Line	Число витков проволоки при числе подвешенных проводов			
	1 до 6 (вкл.) 2	7-12	13-16	17-24
О & N О и Н	4	4	4	4-6
У U	4	6	8	8
ОУ OU	4	6	10	10

Key: 1. Number of turns of wire for the following number of suspended lines:  
2. Up to 6 (inclusive).

Complex ferrocement support poles, for example, twin and anchored types, are made up of two intermediate support poles and are secured by guy wires with stay blocks.

To protect against damage to the concrete and the reinforcement fittings, the lower part of ferrocement poles, which are set up in salt marsh and peaty soils, in cities, and along electrified railroad lines, are coated with asphalt.

#### The Electrical Characteristics of Open Wire Circuits

The transmission parameters are broken down into primary and secondary ones, and the electrical characteristics of open wire communications line circuits are given in the appendix.

The primary transmission parameters are the active resistance, R, the inductance L, the capacitance C, and the conductivity of the insulation, G. The DC resistance of two wire circuits of open wire communications lines,  $R_o$ , at a temperature of +20° C is determined by the expression

$$R_o = \rho \frac{2550}{d_o^2} \text{ Ohms/Km} \quad (3.3)$$

where  $\rho$  is the specific resistivity of the conductor metal, Ohm · mm<sup>2</sup>/m, at  $t = 20^\circ \text{C}$  (Table 3.20);  $d_o$  is the diameter of the conductor, mm.

TABLE 3.20. The Specific Resistivity and Resistive Temperature Coefficient

Conductor Material	Specific Resistivity at + 20° C, Ohm · mm <sup>2</sup> /m	Resistive Temperature Coefficient
Copper	0.01785	+0.0039
Standard Steel	0.139	+0.0046
Copper Steel	0.146	+0.0046

At a temperature  $t$ , other than  $+20^\circ \text{C}$ ,  $R_t$  is determined from the formula:

$$R_t = R_0 [1 + \alpha_{R_0} (t - 20^\circ)] \quad (3.4)$$

where  $\alpha_{R_0}$  is the temperature coefficient of resistance (Table 3.20).

The active AC resistive component for two wire circuits is determined from the expression:

$$R_{\sim} = R_t [1 + F(x)], \quad (3.5)$$

where  $R_t$  is the DC resistance of the circuit at the temperature  $t$ ;

$F(x)$  is a function which takes into account the increase in resistance due to the skin effect, determined from Table 3.21.

TABLE 3.21. The Functions  $F$ ,  $G$ ,  $H$  and  $Q$  for Various Values of  $x$

$x$	$F(x)$	$G(x)$	$H(x)$	$Q(x)$
0	0	$\frac{x^4}{64}$	0,0417	1,0
0,5	0,000326	0,000975	0,042	0,9998
1,0	0,00519	0,01519	0,053	0,997
1,5	0,0258	0,0691	0,092	0,987
2,0	0,0782	0,1724	0,169	0,961
2,5	0,1756	0,295	0,263	0,913
3,0	0,318	0,405	0,348	0,845
3,5	0,492	0,499	0,416	0,766
4,0	0,678	0,584	0,466	0,686
4,5	0,862	0,669	0,503	0,616
5,0	1,042	0,755	0,530	0,556
7,0	1,743	1,109	0,596	0,400
10,0	2,799	1,641	0,643	0,282
>10,0	$\frac{\sqrt{2x}-3}{4}$	$\frac{\sqrt{2x}-1}{8}$	0,750	$\frac{2\sqrt{2}}{x}$

The quantity  $x$  for different conductors is determined from the formulas:

$$\left. \begin{array}{l} \text{Copper} \quad \text{медных} \quad x = 0,0105 d_0 \sqrt{f} \\ \text{Aluminum} \quad \text{алюминиевых} \quad x = 0,0082 d_0 \sqrt{f} \\ \text{Steel} \quad \text{стальных} \quad x = 0,0375 d_0 \sqrt{f} \end{array} \right\} \quad (3.6)$$

where  $d$  is the diameter of the conductor in mm;  $f$  is the frequency in Hz.

Depending on the meteorological conditions, the AC resistance of a circuit is computed for the most severe conditions at the following temperatures:  $+20^\circ \text{C}$ , dry and damp;  $-20^\circ \text{C}$ , dry;  $+2^\circ \text{C}$ , ice crust;  $-10^\circ \text{C}$ , rime.

The resistance of bimetal conductors is defined as the parallel resistance of conductors of the different metals:

$$R_G = \frac{R_{01}R_{02}}{R_{01} + R_{02}} \quad (3.7)$$

The active resistance of a bimetal conductor at any frequency is determined from the formula

$$R'_G = R'_0 q^2 k', \quad (3.8)$$

where  $R'_0$  is the DC resistance of the solid copper or aluminum conductor, the diameter of which is equal to the diameter of the bimetal conductor, in Ohms/Km;

$$q = \frac{d_2}{d_1}$$

where  $d_1$  is the diameter of the steel core, mm;  
 $d_2$  is the outside diameter of the bimetal conductor, mm;  
 $k'$  is the factor taking the surface effect into account, which depends on  $q$  and the auxiliary quantity  $y$

$$y = 2,124 \frac{d_1}{2} \sqrt{\frac{f}{10^4}}$$

$f$  is the frequency in Hz.

When carrying out the calculation for a steel-aluminum conductor, 1.672 is to be substituted for  $y$  in the formula, instead of the factor 2,124.

The inductance of a two wire open air line communications circuit is defined by the expression:

$$L = \left[ 4 \ln \frac{a}{d_0} + \mu Q(x) \right] 10^{-4}, \quad (3.9)$$

where  $a$  is the spacing between the conductors of the circuit in cm;  
 $d_0$  is the diameter of the conductor, mm;  
 $Q(x)$  is the function determined from Table 3.21.

The inductance of bimetal conductors is equal to:

$$L = \left[ 4 \ln \frac{a}{d_0} + k'' \right] \cdot 10^{-4}, \quad (3.10)$$

where  $a$  is the spacing between the conductors, cm;  
 $d_0$  is the diameter of the bimetal conductor, mm;  
 $k''$  is the factor which takes into account the influence of the surface effect (determined from the table found in ITSE, the issue on "Kabel'nyye i vozduzhnyye linii svyazi" ["Cable and Open Wire Communications Lines"], Moscow, "Svyaz'" publishers, 1966 (page 331, as a function of the quantities  $y$  and  $q$ ).

The inductance of the circuits does not depend on the presence of hoarfrost and ice build up on the conductors.

The capacitance of a two conductor circuit for open wire communications lines is determined from the formula:

$$C = \frac{1,05}{36 \ln \frac{a}{d_0}} \cdot 10^{-6}, \quad (3.11)$$

The insulation conductivity of open wire circuits depends on the frequency, weather, and condition of the line insulators, and is determined from the formula:

$$G = G_0 + nf \quad (3.12)$$

where  $G_0$  is the DC insulation conductivity;

$n$  is the factor taking into account the losses in the dielectric for alternating current;

$f$  is the frequency in Hz.

During dry weather,  $G_0$  is taken as  $G_0 = 0.01 \cdot 10^{-6}$  mho/Km, and  $n = 0.05$ , while for summertime dry weather,  $G_0 = 0.5 \cdot 10^{-6}$  mho/Km, and  $n = 0.25$ .

Included among the secondary transmission parameters for communications circuits are the characteristic impedance  $Z_B$ , and the wave propagation factor  $\gamma$ .

The characteristic wave impedance for open wire communications circuits is determined by the expression:

$$Z_B = \sqrt{\frac{R + i\omega L}{G + i\omega C}} \quad (3.13)$$

For circuits of nonferrous metal at frequencies above 10 KHz, the characteristic is determined from the simplified formula:

$$Z_B = \sqrt{\frac{L}{C}} \quad (3.14)$$

The wave propagation factor for all frequencies which can be transmitted is determined by the expression:

$$\gamma = \alpha + i\beta = \sqrt{(R + i\omega L)(G + i\omega C)}, \quad (3.15)$$

where  $\alpha$  is the attenuation is the attenuation coefficient, dB/Km (Nep/Km);  
 $\beta$  is the phase coefficient, radians/Km.

The attenuation factor for an open wire line communications circuit in the case of ice build-up is determined from the formula:

$$\alpha_r = \alpha + \Delta\alpha_r, \quad (3.16)$$

where  $\alpha$  is the attenuation factor of the circuit in the absence of ice, dB/Km (Nep/Km);

$\Delta\alpha_r$  is the increment for the circuit attenuation factor occasioned by electromagnetic energy losses during icing, dB/Km (Nep/Km).

The quantity  $\Delta\alpha_{\Gamma}$  is determined from the approximate formula:

$$\Delta\alpha_{\Gamma} = \frac{1}{2} \beta \frac{\epsilon''}{(\epsilon')^2 + (\epsilon'')^2} \frac{\ln \frac{r_{\Gamma}}{r}}{\ln \frac{a}{r}} \quad (3.17)$$

where  $\beta$  is the phase coefficient in the absence of ice build-up;

$\frac{\epsilon''}{(\epsilon')^2 + (\epsilon'')^2}$  is the dielectric permeability factor of the ice (at a

frequency of 0.8 KHz, it is  $2.1 \cdot 10^{-3}$ , at 10 KHz,  $2.5 \cdot 10^{-3}$ , and at 30 KHz,  $73 \cdot 10^{-3}$ );

$r_{\Gamma}$  is the equivalent radius of the ice build-up formation, cm;

$r$  is the radius of the conductors, mm;

$\alpha$  is the spacing between the conductors, cm.

The phase factor and the characteristic impedance of the circuit for ice formations is determined from the approximate formulas:

$$\beta_{\Gamma} = \beta \left[ 1 + \frac{1}{2} \frac{\ln \frac{r_{\Gamma}}{r}}{\ln \frac{a}{r}} \right]; Z_{\Gamma} = Z_B \left[ 1 - \frac{1}{2} \frac{\ln \frac{r_{\Gamma}}{r}}{\ln \frac{a}{r}} \right] \quad (3.18)$$

The equivalent radius of the ice formation is defined in terms of the mass of the ice or hoar frost build-up,  $P_r$ , i.e. the weight of the water in grams per running meter of conductor:

$$r_{\Gamma} = \sqrt{\frac{P_r}{3,14 \cdot 0,9} + r^2} \quad (3.19)$$

The thickness of the ice build-up layer as a function of the weight of the water per one running meter amounts to 3 mm for a water weight of 50 g, and up to 12 mm for a water weight of 500 g, while for hoar frost, it is 5 and 20 mm respectively.

The parameters for the coupling between open wire line communications circuits are the crosstalk attenuation and the isolation.

The crosstalk attenuation is expressed as the logarithm to the base ten or 1/2 the natural log of the ratio of the power of the generator  $P_1$  driving the exciting circuit to the power of the interference  $P_2$  in the circuit subject to the influence, and is measured in dB or Nep respectively:

$$A = 10 \lg \left| \frac{P_1}{P_2} \right|, \text{ dB}; A = \frac{1}{2} \ln \left| \frac{P_1}{P_2} \right|, \text{ Нп. Неп.} \quad (3.20)$$

For the case of identical matched loads on the mutually influencing circuits, it can also be represented as the ratio of voltages or currents in the



driving ( $u_1, I_1$ ) and in the driven ( $u_2, I_2$ ) circuits:

$$A = 20 \lg \left| \frac{u_1}{u_2} \right| = 20 \lg \left| \frac{I_1}{I_2} \right| \text{ дБ или дБ, or} \\ A = \ln \left| \frac{u_1}{u_2} \right| = \ln \left| \frac{I_1}{I_2} \right| \text{ Нп. Нер} \quad (3.21)$$

In considering the coupling between communications circuits, two forms of energy transfer are distinguished: at the near end, and at the far end. The influence manifest at the end of the circuit where the generator is located is defined as the crosstalk attenuation at the near end,

$$A_0 = 10 \lg \left| \frac{P_{10}}{P_{20}} \right| \text{ дБ или } A_0 = \frac{1}{2} \ln \left| \frac{P_{10}}{P_{20}} \right| \text{ Нп,} \\ \text{дБ or Нер} \quad (3.22)$$

where  $P_{10}$  is the power at the near end of the driving circuit,  
 $P_{20}$  is the interference power at the near end of the circuit which is driven.

In the case of identical circuits ( $Z_{B1} = Z_{B2}$ ), the magnitude of the crosstalk attenuation at the near end can be expressed in terms of the corresponding voltages and currents:

$$A_0 = 20 \lg \left| \frac{u_{10}}{u_{20}} \right| = 20 \lg \left| \frac{I_{10}}{I_{20}} \right| \text{ дБ или дБ, or} \\ A_0 = \ln \left| \frac{u_{10}}{u_{20}} \right| = \ln \left| \frac{I_{10}}{I_{20}} \right| \text{ Нп. Нер.} \quad (3.23)$$

The influence manifesting itself at the opposite end, remote from the generator, is defined as the crosstalk at the far end:

$$A_l = 10 \lg \left| \frac{P_{10}}{P_{2l}} \right| \text{ дБ или } A_l = \frac{1}{2} \ln \left| \frac{P_{10}}{P_{2l}} \right|, \text{ Нп,} \\ \text{дБ, or Нер.} \quad (3.24)$$

where  $P_{10}$  is the power of the generator connected into the driving circuit (at the near end);

$P_{2l}$  is the power of the interference in the circuit, subject to the influence at the far end.

For identical circuits, the crosstalk attenuation at the far end is defined as:

$$A_l = 20 \lg \left| \frac{u_{10}}{u_{2l}} \right| = 20 \lg \left| \frac{I_{10}}{I_{2l}} \right| \text{ дБ или дБ, or} \\ A_l = \ln \left| \frac{u_{10}}{u_{2l}} \right| = \ln \left| \frac{I_{10}}{I_{2l}} \right| \text{ Нп. Нер} \quad (3.25)$$

Most frequently employed in communications engineering is the parameter for the coupling, the *circuit isolation*,  $A_i$ , which takes the form of the difference between the useful signal power and the noise power,  $A = P_s - P_n$ . For

circuits with identical parameters, the isolation  $A_i$  is numerically equal to the difference between the crosstalk attenuation of the cable at the far end and its inherent attenuation  $\alpha l$ :

$$A_i = A_l - \alpha l \quad (3.26)$$

The isolation between circuits at the far end can be defined by the expression:

$$A_{st} = 10 \lg \left| \frac{P_1}{P_{2t}} \right| \text{ dB или } A_{st} = \frac{1}{2} \ln \left| \frac{P_{1t}}{P_{2t}} \right| \text{ Нп. Неп} \quad (3.27)$$

For the case of audio frequency communications, the magnitude of the crosstalk attenuation is normalized at the near end,  $A_0$ , and for high frequency multiplexing, the magnitude of the crosstalk attenuation at the near end,  $A_0$ , and the isolation at the far end,  $A_i l$ , are normalized. Under the existing norms, these quantities are specified in nepers, so that the resulting crosstalk attenuation at the near end,  $A_0$ , between any pair of circuits at a frequency of 800 Hz should not be less than 75.5 dB (8.7 Nep). This norm is defined for a useful signal reception level of 28.6 dB (3.3 Nep). If the level is higher, then the crosstalk attenuation norm can be decreased. Thus, for example, if the useful signal level is 1.0, then  $A_{op} = 54.7$  dB (6.3 Nep).

For multiplexed, the magnitude of the crosstalk attenuation is normalized for the purpose of eliminating the influence at the far end due to reflection from the near end. The resulting crosstalk attenuation at the near end of the line between multiplexed circuits of identical material, over the amplified section throughout the frequency range of the multiplexing, should not be less than the quantity:

$$A_{op} = A_3 + \frac{1}{2} \ln N + \ln \sqrt{2} p + 0,4, \quad (3.28)$$

where  $A_3$  [ $A_i$ ] is the norm for the isolation of the useful signal from the interference. The magnitude of the isolation from the audible crosstalk conversation on a steel circuit is 46.9 dB (5.4 Nep), and for a copper or bimetal (TsM) circuit, is 50.3 dB (5.8 Nep);  $N$  is the number of amplifier stages between the repeater stations. The magnitude of  $N$  is determined from Table 3.22;  $p$  is the reflection factor. For the case of matched devices, it is assumed equal to 0.2 for frequencies up to 30 KHz, and 0.1 for frequencies above 30 KHz.

The norms for the resulting crosstalk attenuation at the near end of the line at frequencies up to 30 KHz, between steel circuits, are given in Table 3.23.

The norms for the resulting crosstalk attenuation at the near end of the line between a nonferrous metal circuit and a steel one can be determined from the following expressions.

For frequencies transmitted via a nonferrous metal circuit from the far end:

$$A_{op} = A_i + \ln p + 0,4 + \alpha_{st} l_{st} + P_{nfm} - P_{st} - \alpha_{nfm} l_{nfm} \quad (3.29)$$

TABLE 3.22.

Values of  $1/2 \ln N$ 

$N$	Values of $1/2 \ln N$													
	1	2	3	4	5	6	7 и 6	9	10-12	13-14	15-18	19-18	23-26	27-30
$\frac{1}{2} \ln N$	0	0,3	0,6	0,7	0,8	0,9	1,0	1,1	1,2	1,3	1,4	1,5	1,6	1,7

Table 3.23. Norms for the Resulting Crosstalk Attenuation on the Amplified Section Between Multiplexed Circuits at Frequencies of up to 30 KHz

1. Число усиленных участков	Norms for the Resulting Crosstalk Attenuation on the Amplified Section Between Multiplexed Circuits at Frequencies of up to 30 KHz													
	1	2	3	4	5	6	7	8	9	10	11	12	13	14
2. Переходное затухание дБ (Нп)	39,0 (4,5)	41,7 (4,8)	44,3 (5,1)	45,1 (5,2)	46,0 (5,3)	46,9 (5,4)	47,7 (5,5)	47,7 (5,5)	48,6 (5,6)	49,5 (5,7)	49,5 (5,7)	49,5 (5,7)	50,3 (5,8)	50,3 (5,8)

Footnote: For copper and bimetallic circuits, the norms are increased by 0.4 nepers.

Key: 1. Number of amplified sections;  
2. Crosstalk attenuation, dB (Nep).

For the frequencies transmitted via a nonferrous metal circuit from the near end:

$$A_{op} = A_i + \ln p + 0.4 + \alpha_{st} + P_{nfm} - P_{st} - \alpha_{nfm}(2l_{nfm} - l_{st}) \quad (3.30)$$

In these expressions,  $A_i = 46.9$  dB (5.4 Nep);  $p$  is the reflection factor (0.2);  $P_{nfm}$  and  $P_{st}$  are the transmission levels at the beginning of the nonferrous metal circuit and the steel circuit respectively;  $\alpha_{nfm}$  and  $\alpha_{st}$  are the attenuation coefficients for the nonferrous metal circuit and the steel one respectively;  $l_{nfm}$  and  $l_{st}$  are the lengths of the amplified section of the nonferrous metal and steel circuits respectively.

The norm for the isolation between the circuits at the far end is determined from the formula:

$$A_{st} = 5,4 + \frac{1}{2} \ln N, \quad (3.31)$$

where  $N$  is the number of amplifier sections between the repeater stations.

#### The Transposition of Telephone Circuits

In order to decrease the mutual influence between open wire communications line circuits, the telephone circuits are transposed, which consists in the systematic mutual alternation of the positions of the circuit conductors. To carry out the transposition, the lines are broken down into sections. The section of a line, over the extent of which a complete transposition cycle is made, is called a *transposition section*. The section is subdivided into short sections of equal length (usually two spans) termed *elements*. The lines of rural telephone networks with span lengths of 83.3 and 100 m have average element lengths of 83.3, 100, 166.6 and 200 m.

There are main sections, which consist of 128 or 256 elements, and abbreviated sections, consisting of 64, 32, 16 and 8 elements. For each circuit, a set order for the transposition ordering is established over the extent of the section, called the *transposition configuration*, and which is designated by simple indices (1/2, 1, 2, 4, 8, 16, 32, 64 and 128), or by combinations of indices (1-2-16-64; 8-16-32). The index 1/2 indicates that the transposition of the circuit conductors is accomplished uniformly over half of an element, i.e. at each support pole; 1 indicates that this is done for each second support pole; the index 2 indicates that it is done for each fourth support pole, etc. A combination of indices, for example, 1-2-16-64, indicates that the transposition is carried out nonuniformly, i.e. on the 1, 3, 5, 7, 9, 11, 13, 15, 16, 17th, etc. elements.

Standard transposition circuits have been worked out for all open wire communications line configurations. Shown in Figure 3.8 are typical configurations for certain of the most frequently encountered configurations on rural telephone networks.

The placement of steel circuits, which are multiplexed up to 30 KHz, on the support poles, where typical transposition configurations are used, is shown in Table 3.24.

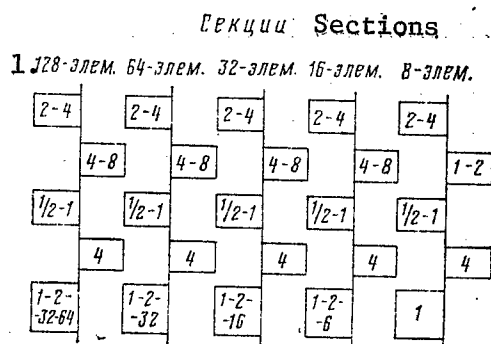
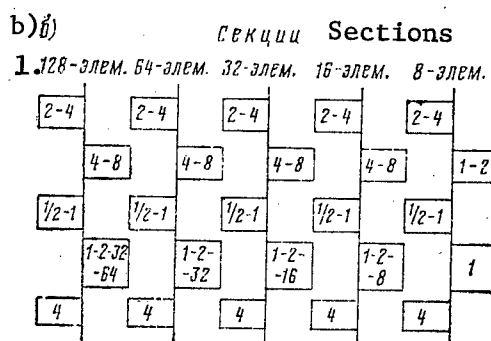
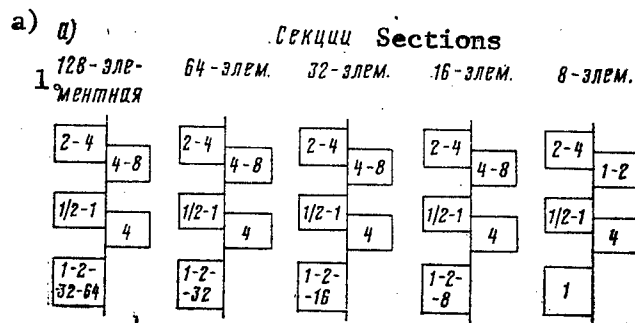

Figure 3.8. Standard transposition configurations for the most frequently encountered support pole configurations:

a) No. 1; b) No. 1a;

Key: 1. 128 element [section].

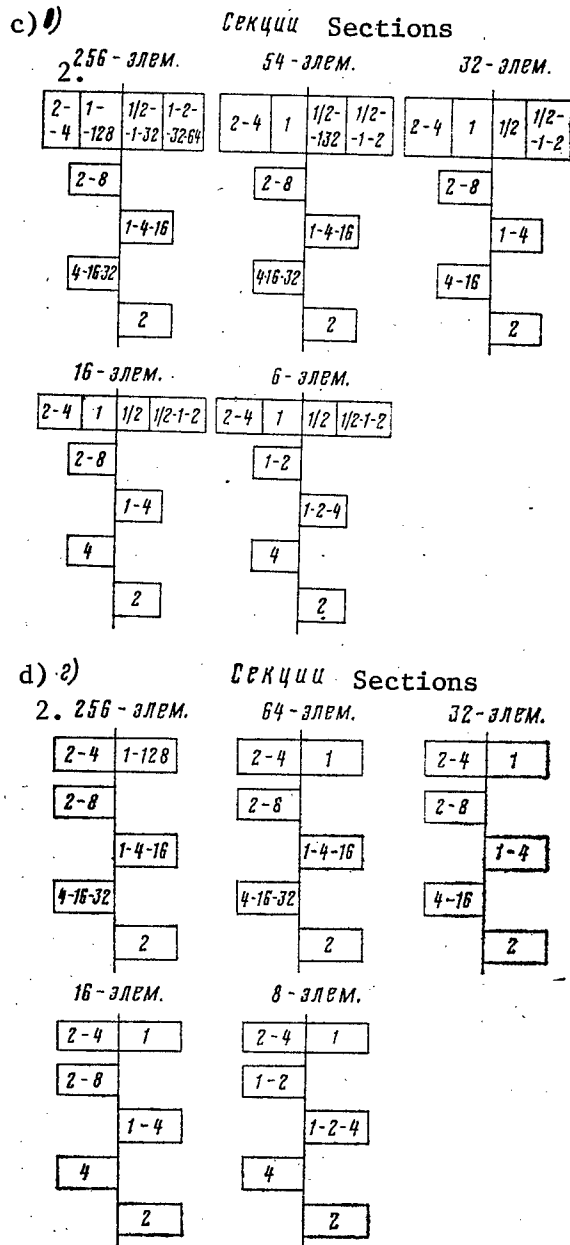

Figure 3.8. Standard transposition configurations for the most frequently encountered support pole configurations:

c) No. 2 and 2a; d) No. 6 and 6a.

Key: 2. 256 element [section].

e)  $\bar{d}$       СЕКЦИИ Sections

256-ЭЛЕМ.		64-ЭЛЕМ.		32-ЭЛЕМ.	
2-4	1-128	2-4	1	2-4	1
$\frac{1}{2}$ 2-1-4-32	2-8-32	$\frac{1}{2}$ 2-1-4-32	2-8-32	$\frac{1}{2}$ 2-1-4	2-8
1-4-16-32	$\frac{1}{2}$ 2-1-4-8	1-4-16	$\frac{1}{2}$ 2-1-4-8	1-4-16	$\frac{1}{2}$ 2-1-4-8
16-32		16-32		4	
	2		2		2

16-ЭЛЕМ.		8-ЭЛЕМ.	
2-4	1	2-4	1
$\frac{1}{2}$ 2-1-4	2-8	$\frac{1}{2}$ 2-1-4	2
$\frac{1}{2}$ 2-1	$\frac{1}{2}$ 2-1-4-8	$\frac{1}{2}$ 2-1	$\frac{1}{2}$ 2-1-4
4		4	
	2		2

f)  $\bar{e}$       СЕКЦИИ Sections

256-ЭЛЕМ.		64-ЭЛЕМ.		32-ЭЛЕМ.	
2-4	1-128	2-4	1	2-4	1
$\frac{1}{2}$ 2-1-4-32	2-8-32	$\frac{1}{2}$ 2-1-4-32	2-8-32	$\frac{1}{2}$ 2-1-4	2-8
1-4-16-32	$\frac{1}{2}$ 2-1-4-8	1-4-16	$\frac{1}{2}$ 2-1-4-8	1-4-16	$\frac{1}{2}$ 2-1-4-8
16-32	2	16-32	2	4	2
2-8	4-32	2-8	4-32	2-8	4

16-ЭЛЕМ.		8-ЭЛЕМ.	
2-4	1	2-4	1
$\frac{1}{2}$ 2-1-4	2-8	$\frac{1}{2}$ 2-1-4	0
$\frac{1}{2}$ 2-1	$\frac{1}{2}$ 2-1-4-8	$\frac{1}{2}$ 2-1	$\frac{1}{2}$ 2-1-4
4	2	4	2
2-8	1-2	1-2	4

Figure 3.8. Standard transposition configurations for the most frequently encountered support pole configurations:

e) No. 7 and 7a; f) No. 8.

TABLE 3.24. The Positioning of Steel Circuits on Support Poles

1. № профиля	Номера мест на опоре для стальных уплотненных цепей 2.
1	1, 3, 5 &
1a	1, 2, 3, 4 и 5
2	1, 2, 3, 4, 5, 7 <sup>or</sup> 1, 2, 3, 4, 6 и 8
2a	1, 2, 3, 4, 5, 6, 7, 8
6	1, 2, 4, 6
6a	1, 2, 3, 4, 5, 6
7	1, 2, 3, 4, 5, 6, 8
7a	1, 2, 3, 4, 5, 6, 7, 8
8	1, 2, 3, 4, 5, 6, 7, 8, 9, 10

Key: 1. Configuration No.; 2. Number of locations on the support pole for steel multiplexed circuits.

**СЕКЦИИ Sections**

128-ЭЛЕМ.				64-ЭЛЕМ.				32-ЭЛЕМ. 32 Element			
8-16-32	16-32-64	8-16-64	16-64	8-16-32	16-32	8-16	16	4-16	2-8	8-16	16
16	8	16-32	8-16-32	16	8	16-32	8-16-32	16	8	4	2-4-8
8-16	16-64	8-32	16-32-64	8-16	16	8-32	16-32	8-16	16	2-4-8	2-8
16-32	8-16-32	16	8	16-32	8-16-32	16	8	4	2-4-8	16	8
8-32	16-32-64	8-16	16-64	8-32	16-32	8-16	16	2-4-8	2-8	8-16	16

16-ЭЛЕМ.				8-ЭЛЕМ. 8 Element			
2-4	2-8	4-8	1-2	2-4	1	2	1-2
4-8	8	4	2-8	1-2	1-2-4	4	2-4
8	4-8	2-4	4	2-4	1-2	2-4	4
4	2-8	4-8	8	4	2-4	1-2	1-2-4
2-4	4	8	4-8	2-4	4	2-4	1-2

Figure 3.9. The transposition configurations for subscriber telephone circuits.

The following circuit positioning is provided on open wire communications line support poles for rural telephone networks. For one and two stage network configurations, circuits are positioned on the first and second cross-arms, which are intended for multiplexing and have conductors of the same material and diameter. The subscriber lines are positioned below the multiplexed circuits.

The transposition configurations for subscriber telephone circuits are shown in Figure 3.9. Where there are cable mounting installations at the crossovers



or feed-ins into the exchange building, the transposition configuration is realized without taking into account the cable mounting installation. When conductors are connected to the cable cores, care must be taken that the circuit is not artificially transposed. One does not have to transpose subscriber circuits with lengths up to two kilometers.

Subscriber circuits can be branched from any support pole. One can branch high frequency steel circuits:

- For a 128 element section, at the end of the 32nd, 64th, 96th and 128th element;
- For a 64 element section, at the end of the 16th, 32nd, 48th and 64th element;
- For a 32 element section, at the end of the 8th, 16th, 24th and 32nd element;
- For a 16 element section, at the end of the 8th and 16th element;
- For an 8 element section, at the end of the 8th element.

The branching off of steel, nonmultiplexed circuits of junction lines, where multiplex circuits are present over the same line, should be accomplished from the 8th, 16th, 32nd, 48th or 64th element. On lines where there are no multiplexed circuits, the branching device is permitted at any point on the section.

The transposition of telephone circuits and radio repeater circuits, colocated on common support poles, is accomplished in accordance with the "Instruktsiya po podveske fidernykh radiotranslyatsionnykh tsepey i tsepey sel'skoy telefonnoy svyazi" ["Instructions for Stringing Feeder Radio Repeater Circuits and Rural Telephone Communications Circuits"], (Moscow, Svyaz' Publishers, 1964).

#### The Construction of Open Wire Lines

The construction of open air lines is realized in accordance with project plans, and includes: laying out the lines over the terrain; cutting out a cleared strip, branches and undergrowth; digging out the holes and delivering the materials to several places; rigging, installing and securing the support poles; unwinding and stringing the wires; numbering the support poles and the wires.

When laying out the line over the terrain, the locations for setting up each support pole are marked by wooden stakes, the line is run straight between its turning points, and the set spacings between the support poles and the line turning angles are observed. Outside of populated points, the normal departure angle should not exceed 15 m, i.e. the internal turning angle should not be less than 145°, while the outer one, not greater than 35°. Given in Table 3.25 are the angular departures corresponding to the normal departure for span lengths of 60 and 40 m.

TABLE 3.25. Angular Departures Corresponding to the Standard One for Span Lengths of 60 and 40 Meters

1. Внутренний угол поворота, °	2. Нормальный вылет, м	3. Вылет углов, град, при пролете, м	
		60	40
173	3	3,6	2,4
168,5	5	6	4
163	7,5	9	6
157	10	12	8
145	15	18	12

Key: 1. Internal turning angle, in °; 2. Normal departure, in m;  
3. Departure of the angles, in °, for a span length, in m, of:.

The holes are dug out mechanically using BKGM-AN-63, BUS-6 or D-453 crane drilling rigs. When done manually, the holes are dug out in a stepped trapezoidal shape. A hole for the pole brace is dug at the same as the hole for the corner or feed-in support pole. The spacing between the hole for the pole and the hole for the pole brace is 4 m for a pole length of 6.5 m.

Rigging the support poles consists in cleaning the support pole, dressing its upper part, rough hewing the top to a double slope, drilling the holes, screwing in the hooks or securing the crossbar, mounting the hooks or extension fishplates for transposition, and screwing on the insulators. The spacing between the hooks and the crossarms is chosen in accordance with Figure 3.1. Two hooks are mounted on corner support poles when the departure of the angle is greater than 7.5 meters for type O and N lines, and 5 meters for type U and OU lines; and for the crossarm configuration of the line, the crossarms are mounted in a plane dividing the angle in half. Dual crossarms are set up. When the departure of the angle is greater than 7.5 meters on the support poles, which are adjacent to the corner pole, the crossarms are placed on the side of the corner support pole. Lightning rods and grounds are rigged on support poles, where a provision is made for this in the plan.

The support poles are set up using a crane drilling rig, or manually by means of a lever and cant hooks. After being set up, the support pole is tilted, lined up and tamped in.

When constructing a line in rugged terrain, and using a crossing unit, the line is gradually raised and lowered in a vertical plane so that the suspension points of the conductors on two adjacent support poles do not differ by more than 2 m.

Before stringing a steel wire, it is stretched out by means of tackle blocks, and the magnitude of the force, which is monitored by a dynamometer, should not exceed 230 Kg for a 4 mm diameter wire, and 130 Kg for a 3 mm diameter wire. The wire is inspected after being stretched. On copper and bimetal line wires, rough places and bends which are detected are smoothed out with a wooden hammer on a flat piece of wood.

The ends of steel conductors are joined together using type 1-3.2 thermite muffle cartridges for 3 mm diameter conductors, and 2-4.2 types for 4 mm diameter conductors. A steel conductor is joined to a bimetal one by the same method. In the absence of thermite muffle cartridges, the steel wires are joined together by soldering. The cleaned and tinned ends of the conductors are placed against each other, wound with soft steel, galvanized wire having a diameter of 1 mm, are soldered over a length of 40 - 50 mm, the ends of the line wire are bent back, and the winding with the tie wire is continued for 10 - 15 mm.

The ends of copper and bimetal conductors are joined together by copper tubes using a special screw stock and wrench. For 2.5 mm diameter conductors, tubes with a hole diameter of 2.8 mm and a length of 100 mm are used, and for 3.0 mm conductors, a 3.3 x 120 mm tube, and for a diameter of 4 mm, a 4.4 x 150 mm tube. Small diameter (1.5 - 2 mm) steel and bimetal conductors are connected together by double twisting.

The conductors are unwound from cable drums which are moved along the line on a motor vehicle or wagon.

After splicing, the steel conductors are stretched out by tackle blocks, while copper and bimetal ones are lined up without tensioning.

The stringing and tying of the conductors is accomplished simultaneously on several (four to five) adjacent support poles. The wires which are positioned on the insulators and secured at the end pole are tensioned by tackle blocks until achieving the specified suspension sag (Table 3.10) and are secured with binding wire. On the intermediate support poles (in a straight line), the conductor is secured in the recess of the insulator head, and at corner poles, on the neck of the insulator.

The support poles on rural communications lines are numbered with sequential numbers, where the digits are positioned horizontally, and above the digits, the two last digits indicate the year the pole is set up. If there are more than a thousand support poles on a line, then the digits designated the thousands are written only on each tenth support pole. The support poles are numbered beginning with the feed-in one standing close to the terminal or amplifier point, and which has the number zero. The count is conducted from the regional center (or central exchange), while in the case of points of equal value, from the north to the south, and from west to east.

### 3.2. RURAL COMMUNICATIONS CABLE LINES

#### Structure of the Cables

The following cables (conductors) belong to single pair rural communications cables (Figure 3.10): PRVPM (a polyvinylchloride pair with copper cores); PRPPM (a line with polyethylene insulation and jacketing, and copper cores); PTPZh and PTVZh (telephone line, polyvinylchloride or polyethylene with steel

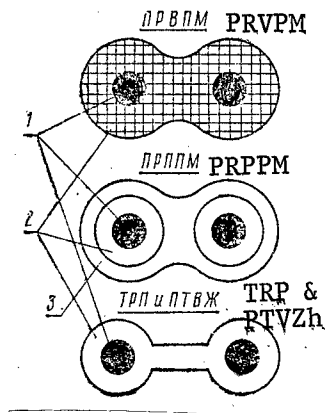

Figure 3.10. The construction of single pair cables for standard profiles:

1. Current carrying cores;
2. Insulation;
3. Jacket.

systems. In regions inhabited by rodents, single quadded cables with armor and thin steel tape (VTSPB and KSPPB) are used. KSPPK cable is recommended for runs through water barriers (rivers and lakes).

The design of single quadded cables permits the mechanized and manual laying of these cables directly in the ground, running them in a cable conduit, as well as stringing them on open wire line support poles by means of special support cables.

The laying and installation of single quadded cables is permitted at ambient temperatures of no less than  $-10^{\circ}\text{C}$ , and their operation is permitted within a temperature range of  $-40$  to  $+50^{\circ}\text{C}$ .

The main structural data for single quadded cables for rural communications are given in Table 3.27.

Multipair cables, used on city telephone networks (Figure 3.12), have found application at the present time on rural telephone networks. These cables include cables of the T and TZ types (telephone pair or quadded twist (spiral quad) with paper insulation in a lead jacket), as well as TPP and TPV (telephone type with polyethylene insulation in a polyethylene or polyvinylchloride jacket). Nonarmored cables of the T (TG), TZ (TZG), TPV and TPP types are intended for laying in cable conduits, in the walls of buildings and for stringing on open wire line support poles by means of support cables. These non-armored cables in the armored variant (TB, TZB, TPVB and TPPB) are intended

TRV, TRP (telephone, distribution, polyvinylchloride or polyethylene); ATRV, ATRP (telephone, distribution, polyvinylchloride or polyethylene with aluminum cores).

Type PRVPM and PRPPM cables are layed directly in the ground both mechanically and manually, and can operate at temperatures of from  $-40^{\circ}$  up to  $+60^{\circ}$  with polyethylene insulation, and  $-30^{\circ}$  up to  $+45^{\circ}$  with polyvinylchloride insulation. Cables of the PTVZh, PTPZh, TRV, ARTV, TRP and ATRP types, which are intended for subscriber feed-in devices and wiring inside buildings, are run in the walls of buildings.

The structural data for single pair cables are given in Table 3.26.

Single quadded cables (Figure 3.11) include cables of the VTSP and KSPP, as well as the KSPV types. These cables are intended for equipping communications lines which are multiplexed using the high frequency V-3-3s, KNK-6S, KNK-6T, KNK-12 and IKM-12

TABLE 3.26. Structural Data for Single Pair Cables

Brand of Cable	Жилы Cores		Изоляция Insulation		Оболочка Jacket		Outside Dimensions	Weight	Строительная длина м 4.
	материал Material	диаметр мм 1.	материал Material	радиальная толщина мм 3.	материал Material	радиальная толщина мм 3.			
PRVPM	5 Медь (MM)	0,8	Поливинилхлорид 6	1,0	—	3,2×6,7	24,2	500	
PRVPM	»	1,0	»	1,2	—	3,8×8,1	36,4	»	
PRVPM	»	1,2	»	1,4	—	4,4×9,3	51,0	»	
PRPPM	»	0,8	Полиэтилен 7	0,7	0,8	3,8×7,6	29,0	»	
PRPPM	»	1,0	»	0,7	0,8	4,0×8,0	36,0	»	
PRPPM	»	1,2	»	0,7	0,8	4,2×8,4	43,8	»	
PTVZh	8. Сталь	0,6	Поливинилхлорид 6	0,6	—	2,0×6,0	10,5	100	
PTVZh	»	1,2	»	0,7	—	2,8×7,6	28,9	»	
PTVZh	»	1,8	»	0,8	—	3,6×9,2	57,3	»	
PTPZh	»	0,6	Полиэтилен 7.	0,6	—	2,0×6,0	8,6	»	
PTPZh	»	1,2	»	0,7	—	2,8×7,6	25,3	»	
PTPZh	»	1,8	»	0,8	—	3,6×9,2	51,7	»	
TRV	Медь (MM) 5.	0,5	Поливинилхлорид 6	0,7	—	2,3×6,6	13,0	200	
ATRV	9 Алюминий (AM)	0,7	»	0,7	—	2,5×7,0	12,8	»	
TRP	Медь (MM) 5.	0,5	Полиэтилен 7.	0,7	—	2,3×6,6	10,0	»	
ATRP	9 Алюминий (AM)	0,7	»	0,7	—	2,5×7,0	9,4	»	

Key: 1. Diameter, mm; 2. Radial thickness, mm; 3. Radial thickness, mm;  
 4. Structural length, m; 5. Copper (MM); 6. Polyvinylchloride; 7. Polyethylene;  
 8. Steel; 9. Aluminum (AM).

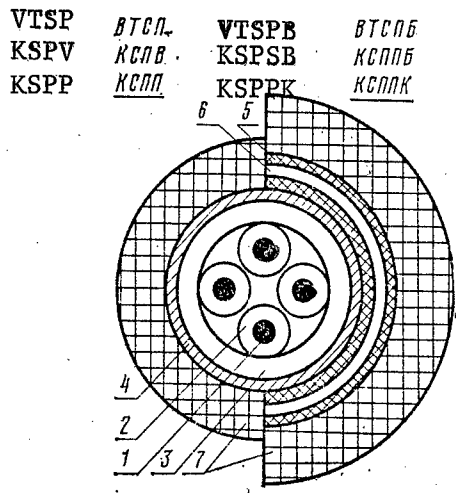

Figure 3.11. The structure of single quadded cables.

- Key: 1. Current carrying cores;  
 2. Core insulation;  
 3. Strip insulation;  
 4. Shield;  
 5. Lining;  
 6. Armor;  
 7. Jacket (plastic).

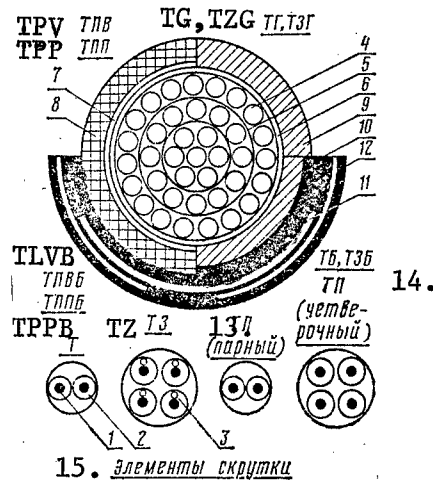

Figure 3.12. The structures of multipair (multiquadded) cables.

- Key: 1. Current carrying cores;  
 2. Core insulation; 3. Paper cord;  
 4. Twist elements; 5. Thread (cotton paper or synthetic); 6. Strip insulation; 7. Shield; 8. Jacket (plastic); 9. Jacket (metal); 10. Jute cushion; 11. Armor; 12. Exterior jute cover; 13. TP (pair); 14. TB, TZB, TP (quadded); 15. Элементы скрутки.

for laying directly in the soil. Armored, circular galvanized wires (TK and TZK) are used for running through water barriers.

Type T cables have current carrying cores of annealed copper wire (MM), insulated with paper tape applied in an overlapping spiral (air - paper insulation) or by a continuous layer of a paper mass (paper - mass insulation). The insulated cores are twisted in pairs with a pitch of no more than 250 mm, and are wound in a spiral with cotton-paper yarn. In each pair, one core has naturally colored insulation, and the other is red or blue. The pairs are twisted in concentric lays (layers), each of which is wound in a spiral with cotton paper yarn. There is a counter pair in each layer, one core of which is distinguished in color from all the other cores of the lay. The outside layer is covered by two overlapping paper tapes.

The main design data for low capacity type T cables having core diameters of 0.5 and 0.7 mm are given in Table 3.28.

Type TZ cables have current carrying cores of annealed copper wire (MM), insulated by paper cord and paper tape. The insulated cores are twisted in quads

TABLE 3.27. Basic Structural Data for Single Quadded Cables

Type Марка кабеля of Cable	1. Жилы		6. Изоляция жил				8. Поясная изоляция		10.
	2 материал	3 диаметр мм	4 материал	5 рад. тол- щина мм	Color расцветка Code	7 шаг скрут- ки, мм	9 мате- риал	рад. тол- щина, мм	
ВТСП VTSP	Медь Cu	1, 2	Поли- этилен 11.	0, 8	12. I пара: крас- ная—натур., II пара: си- няя—натураль- ная	150— —170	Поли- этилен 11.	0, 8	
ВТСПБ VTSPB	>	>	>	>	То же The same	>	>	>	
КСПВ KSPV	>	0, 9	>	0, 7	13. I пара: крас- ная натур. II пара: си- няя (зеленая— натуральная)	120— —150	>	>	
КСПП KSPП	>	>	>	0, 7	14. I пара: крас- ная натур., II пара: си- няя (зеленая натуральная)	120— —150	>	0, 8	
КСППБ KSPPB	>	>	>	>	То же The same	То же	>	>	
КСППК KSPPK	>	>	>	>	>	>	>	>	

Key: 1. Cores; 2. Material; 3. Diameter, mm; 4. Material; 5. Radial thickness, mm; 6. Core insulation; 7. Pitch of the twist, mm; 8. Strip insulation; 9. Material; 10. Radial thickness; 11. Polyethylene; 12. First pair: red--natural; second pair: blue--natural; 13. First pair: red--natural; second pair: blue (green--natural); 14. First pair: red--natural; second pair: blue (green--natural).

Table 3.27 [Continued] Basic Structural Data for Single Quadded Cables

	1. Экранирующие покрытия		3. Оболочка		6. Наруж. диаметр, мм	7. Масса, кг/км	8. Структур. длина м
	Material and Shape	2. кол-во и размер, мм	4. материал	5. рад. тол-щина, мм			
A.	1. Медная жила 2. Алюминиевая лента	$d=0,3 \pm 0,5$ $1 \times 0,1 \times 25$	9. Поливинилхлорид или полиэтилен	1,5	13	160	700
B.	1. Медная жила 2. Алюминиевая лента 3. Поливинилхлоридная лента 4. Стальная лента (броня) 5. Поливинилхлоридная лента	$d=0,3 \pm 0,5$ $1 \times 0,1 \times 25$ $1 \times 0,2$ $1 \times 0,1 \times 15$ $1 \times 0,2$	То же The same	>	15	255	500
C.	1. Медная жила 2. Алюминиевая лента	$d=0,3 \pm 0,5$ $1 \times 0,1 \times 25$	10. Поливинилхлорид	>	10,4	127	750
D.	1. Медная жила 2. Алюминиевая лента	$d=0,3 \pm 0,5$ $1 \times 0,1 \times 25$	11. Полиэтилен	>	10,4	105	750
E.	1. Медная жила 2. Алюминиевая лента 3. Поливинилхлоридная лента 4. Стальная лента (броня) 5. Поливинилхлоридная лента	$d=0,3 \pm 0,5$ $1 \times 0,1 \times 25$ $1 \times 0,2$ $1 \times 0,1 \times 15$ $1 \times 0,2$	>	>	11,4	181	500
F.	1. Медная жила 2. Алюминиевая лента 3. Поливинилхлоридная лента 4. Стальная проволока (броня)	$d=0,3 \pm 0,5$ $1 \times 0,1 \times 25$ $1 \times 0,2$ $24 \times 1,2$	>	>	13,6	310	>

Key: 1. Shield covers; 2. Number and dimensions, mm; 3. Jacket; 4. Material; 5. Radial thickness, mm; 6. Outside diameter, mm; 7. Weight, Kg/Km; 8. Structural length, m; 9. Polyvinylchloride or polyethylene; 10. Polyvinylchloride; 11. Polyethylene; A.1. [VTSP] Copper core; A.2. Aluminum tape; B.1. [VTSPB] Copper core; B.2. Aluminum tape; B.3. Polyvinylchloride tape; B.4. Steel tape (armor); B.5. Polyvinylchloride tape; C.1. [KSPV] Copper core; C.2. Aluminum tape; D.1. [KSPP] Copper core; D.2. Aluminum tape; E.1. [KSPPB] Copper core; E.2. Aluminum tape; E.3. Polyvinylchloride tape; E.4. Steel tape (armor); E.5. Polyvinylchloride tape; F.1. [KS-PPK] Copper core; F.2. Aluminum tape; F.3. Polyvinylchloride tape; F.4. Steel wire (armor).



(a spiral quad formation) with a pitch of no more than 300 mm, and are wound in a spiral with cotton paper yarn or paper tape. One working pair (the cores on a diagonal) in each quad has red and yellow (or natural) insulation, and the other blue and green. The quads are twisted in concentric lays (layers) each of which is wound in a spiral with cotton paper yarn or paper tape. Two adjacent quads (the control and the counter ones) in each layer have a color distinguishing them from each other and from all remaining quads of the lay. The outside lay is covered by two overlapping paper tapes.

The main structural data for TZ type cable having a capacity of up to 37 quads with core diameters of 0.8 mm, 0.9 mm and 1.2 mm are given in Table 3.28.

Type TPV and TPP cables have current carrying cores of annealed copper wire (MM) insulated with solid polyethylene. The insulated cores, which differ markedly in their color, are twisted in pairs or quads with a pitch of no more than 100 mm. The insulated pairs (quads) are twisted in the core of the lay or bundle twist. In the case of the lay twist, the lays are wound with a lavsan [synthetic fiber similar to dacron], cotton or capron [Soviet name for polycaprolactam resin and fiber] thread. In each lay there is one counter pair or a quad with a sharply distinguishing color code. In the case of a bundle twist, the elemental bundles (10 x 2, or 5 x 4) are wound with a lavsan, capron or cotton paper thread of a specified color.

Applied to the twisted core is strip insulation of plastic tapes having a thickness of 0.1 mm overlapping 20 - 25 percent. A shield of aluminum tape with a thickness of 0.1 - 0.2 mm is applied on top of the strip insulation. In the case of a spiral application with an overlap of 10 percent or a longitudinal application with diameters up to 15 mm, smooth tape is used; with diameters of more than 15 mm, corrugated tape is used. Run longitudinally beneath the tape is a 0.5 mm copper wire.

The basic design data of type TPV and TPP low capacity cables with core diameters of 0.5 and 0.7 mm are given in Table 3.29.

#### Cable Materials

Copper, aluminum and galvanized steel wires, the characteristics of which are given in Table 3.30, while their weights are given in Table 3.31, are used for the manufacture of cable cores.

Polyvinylchloride and polyethylene are used for the most part for the insulation in rural communications cables.

Polyvinylchloride (PKhV) belongs to the group of thermoplastic resins. An important property of PKhV is its nonflammability. PKhV is a plastic used in cable technology as a low frequency dielectric.

The basic characteristics of polyvinylchloride plastic of different compositions are shown in Table 3.32.

TABLE 3.28. The Structural Data for Type T and TZ Cables

Cable Type	Capacity	Core Diameter, mm	1. Кабель небронированный			4. Кабель бронированный			11. наружный диаметр, мм	Weight, kg/km	Строительная длина, м
			2. обложка	3. радиальн. шаг тол. материала	Outside Diameter, mm	2. обложка	3. радиальн. шаг тол. материала	Weight, kg/km			
T	10x2	0.5 0.7	1.2 1.3	1.10 1.15	430 590	1.10 1.15	2x0.3	18.1 20.1	820 980	500	
	20x2	0.5 0.7	1.3 1.4	1.15 1.20	670 900	1.15 1.20	2x0.5	21.6 24.8	1190 1510	*	
T	30x2	0.5 0.7	1.3 1.5	1.15 1.25	820 1270	1.15 1.25	*	23.6 29.0	1400 1990	300	
	50x2	0.5 0.7	1.4 1.6	1.20 1.30	1130 1780	1.20 1.30	*	26.8 33.6	1790 2620	*	
TZ	100x2	0.5 0.7	1.5 1.9	1.25 1.60	1680 2980	1.25 1.60	*	32.5 41.9	2560 4040	250	
	3x4	0.8 0.9 1.2	1.3 1.3 1.3	1.15 1.15 1.15	622 705 841	1.15 1.15 1.15	2x0.3 2x0.5	19.1 20.3 21.8	1057 1160 1480	475	
TZ	4x4	0.8 0.9 1.2	1.3 1.3 1.4	1.15 1.15 1.2	699 796 956	1.15 1.15 1.2	2x0.3 2x0.5	20.1 21.5 23.1	1150 1410 1635	*	

Key: 1. Unarmored cable; 2. Jacket; 3. Radial thickness, mm; 4. Armored cable; 5. Protective cover; 6. Cushion (radial thickness, 1.5 mm); 7. Armor; 8. Material and shape; 9. Size, mm; 10. Outer cover (radial thickness, 2.0 mm); 11. Outer diameter, mm; 12. Structural length, m; 13. Two layers of bitumen, between which there is a layer of impregnated cable yarn (jute); 14. Three layers of bitumen, between which there are the following layers: one of impregnated cable paper, and one of impregnated cable yarn (jute).

TABLE 3.28 [Continued] The Structural Data for Type T and TZ Cables

Cable Type	Cable Capacity Емкость кабеля	Core Diameter жил, мм	1. Кабель небронированный				8. Кабель бронированный				Weight масса, кг/км	Outer Diameter, мм	Structural Length, м		
			2 оболочка		3		5 защитный покров		6					11 наружный покров (радиусная толщина 2,0 мм)	12 наружный диаметр, мм
			Material	радиусная толщина, мм	Material	радиусная толщина, мм	Material и вид	размер	Material	размер					
TZ	7x4	0.8 0.9 1.2	Material 1.3 1.4 1.5	1.3 1.4 1.5	15.1 16.8 19.0	886 1082 1327	Material 1.15 1.2 1.25	1.15 1.2 1.25	2x0.5 * *	10 * *	22.4 24.1 27.1	1550 1818 2152	475 * *		
	12x4	0.8 0.9 1.2	Material 1.5 1.6 1.6	1.5 1.6 1.6	19.8 22.4 25.4	1374 1590 2073	Material 1.25 1.25 1.3	1.25 1.25 1.3	* * *	* * *	27.7 30.3 35.3	2225 2522 3230	* * *		
	14x4	0.8 0.9 1.2	Material 1.5 1.6 1.7	1.5 1.6 1.7	20.8 23.5 26.7	1479 1799 2355	Material 1.25 1.3 1.4	1.25 1.3 1.4	* * *	* * *	28.7 31.4 36.6	2363 2777 3660	* * *		
	19x4	0.8 0.9 1.2	Material 1.6 1.7 1.7	1.6 1.7 1.7	23.3 26.3 29.4	1729 2105 2960	Material 1.3 1.4 1.4	1.3 1.4 1.4	* * *	* * *	31.2 36.2 39.8	2695 3289 4230	* * *		
	27x4	0.8 0.9 1.2	Material 1.7 1.8 2.0	1.7 1.8 2.0	28.1 31.7 36.0	2380 3006 3957	Material 1.4 1.5 1.7	1.4 1.5 1.7	* * *	* * *	38.0 41.6 46.0	3629 4273 5350	* * *		
TZ	37x4	0.8 0.9 1.2	Material 1.8 1.9 2.1	1.8 1.9 2.1	31.6 35.7 40.8	3000 2492 5063	Material 1.5 1.6 1.8	1.5 1.6 1.8	* * *	* * *	41.5 45.6 50.5	4320 5100 767	* * *		

Key: 1. Unarmored cable; 2. Jacket; 3. Radial thickness, mm; 4. Outside diameter, mm; 5. Protective cover; 6. Cushion (radial thickness, 1.5 mm); 7. Armor; 8. Armored cable; 9. Material and shape; 10. Size, mm; 11. Outer cover (radial thickness, 2.0 mm); 12. Outside diameter, mm; 13. Three layers of bitumen, between which there are the following layers: one of impregnated cable paper, and one of impregnated cable fiber (jute); 14. Two layers of bitumen, between which there is a layer of impregnated cable fiber (jute).

TABLE 3.29. The Basic Structural Data for Type TPP and TPV Cables

Cable Capacity Емкость кабеля	1. Диаметр жилы mm		2. Оболочка Material		3. Кабель небронированный б масса, кг/км		4. Кабель бронированный Armored Cable				Строительная длина Structural Length, m
	радиальная толщина, мм	наружный диаметр, мм	TPV	TPP	б масса, кг/км	TPV	TPP	TPV	TPP	TPV	
5×2	0.5 0.7	9.0 10.9	1.5 1.5	78.4 116.0	60.0 99.0	17.2 19.1	368.4 443.5	350.0 426.4	17.2 19.1	13	350 350
10×2	0.5 0.7	11.0 13.6	1.5 1.5	118.5 184.5	101.5 162.7	19.2 22.6	449.0 687.7	432.0 665.0	19.2 22.6	13	350 350
20×2	0.5 0.7	13.6 18.3	1.5 2.0	188.1 341.7	166.4 302.3	22.6 27.3	690.4 975.2	669.0 934.5	22.6 27.3	16	350 350
30×2	0.5 0.7	17.2 22.8	2.0 2.5	289.4 513.3	253.1 452.8	26.2 31.8	894.0 1273.6	698.0 1213.1	26.2 31.8	16	300 300
50×2	0.5 0.7	22.0 29.2	2.5 3.0	472.6 831.4	413.9 737.6	31.0 38.2	1216.2 1778.0	1157.5 1679.1	31.0 38.2	16	300 300
100×2	0.5 0.7	29.8 38.1	3.0 3.0	858.2 1440.3	762.7 1316.3	38.8 47.1	1815.0 2629.3	1719.3 2504.3	38.8 47.1	16	300 300

Key: 1. Core diameter, mm; 2. Jacket; 3. Unarmored cable; 4. Radial thickness, mm; 5. Outside diameter, mm; 6. Weight, Kg/Km; 7. Protective cover; 8. Cushion (radial thickness, 1.5 mm); 9. Armor; 10. Material and shape; 11. Size, mm; 12. Outside cover (radial thickness, 2.0 mm); 13. Outside diameter, mm; 14. Polyvinylchloride (TPV) or polyethylene (TPP); 15. Three layers of bitumen, between which there are layers of impregnated cable paper and impregnated cable fiber (jute); 16. Two layers of bitumen, between which there is a layer of impregnated cable yarn (jute).

TABLE 3.29. [Continued] The Basic Structural Data for Type TPP and TPV Cables

Cable Capacity Емкость кабеля	Core Diameter Диаметр жилы, мм	1. Оболочка Material		2. Кабель небронированный			Armored Cable бронированный Cable						Structural Length, m Структурная длина
		Material	Thickness, mm Толщина, мм	Outer Diameter, mm наружный диаметр, мм	TPV Mass, kg/km масса, кг/км	5. защитный покров		10. Outer Diameter, mm наружный диаметр, мм	11. Outer Diameter, mm наружный диаметр, мм	12. Mass, kg/km			
						TPV	TPP			TPV	TPP	TPV	
5×4	0.5	Polyethylene (TPP) or Polyvinylchloride (TPV)	1.5	10.2	110.0	12. Three layers of bitumen, between which there are the following layers: one of impregnated cable yarn (jute); 13. Two layers of bitumen, between which there is a layer of impregnated cable yarn (jute); 14. Radial thickness, mm.	Steel Tape	2×0.3	13. Two layers of bitumen, between which there is a layer of impregnated cable yarn (jute); 14. Radial thickness, mm.	18.4	423.5	408.0	350
	1.5		12.9	174.8	154.4					21.1	653.0	632.4	
10×4	0.5	Polyethylene (TPP) or Polyvinylchloride (TPV)	2.0	12.8	176.0	12. Three layers of bitumen, between which there are the following layers: one of impregnated cable yarn (jute); 13. Two layers of bitumen, between which there is a layer of impregnated cable yarn (jute); 14. Radial thickness, mm.	Steel Tape	2×0.5	13. Two layers of bitumen, between which there is a layer of impregnated cable yarn (jute); 14. Radial thickness, mm.	21.0	655.0	635.0	300
	2.0		17.5	326.4	289.3					26.5	936.0	898.6	
15×4	0.5	Polyethylene (TPP) or Polyvinylchloride (TPV)	2.0	16.2	270.3	12. Three layers of bitumen, between which there are the following layers: one of impregnated cable yarn (jute); 13. Two layers of bitumen, between which there is a layer of impregnated cable yarn (jute); 14. Radial thickness, mm.	Steel Tape	2×0.5	13. Two layers of bitumen, between which there is a layer of impregnated cable yarn (jute); 14. Radial thickness, mm.	25.2	845.0	811.0	300
	2.5		20.8	449.3	404.5					29.8	1149.3	1104.5	
25×4	0.5	Polyethylene (TPP) or Polyvinylchloride (TPV)	2.5	19.6	396.0	12. Three layers of bitumen, between which there are the following layers: one of impregnated cable yarn (jute); 13. Two layers of bitumen, between which there is a layer of impregnated cable yarn (jute); 14. Radial thickness, mm.	Steel Tape	2×0.5	13. Two layers of bitumen, between which there is a layer of impregnated cable yarn (jute); 14. Radial thickness, mm.	28.6	1066.0	1024.0	300
	3.0		26.2	728.1	656.4					35.2	1591.3	1520.0	
50×4	0.5	Polyethylene (TPP) or Polyvinylchloride (TPV)	3.0	26.3	752.0	12. Three layers of bitumen, between which there are the following layers: one of impregnated cable yarn (jute); 13. Two layers of bitumen, between which there is a layer of impregnated cable yarn (jute); 14. Radial thickness, mm.	Steel Tape	2×0.5	13. Two layers of bitumen, between which there is a layer of impregnated cable yarn (jute); 14. Radial thickness, mm.	35.3	1610.0	1539.0	300
	3.0		35.5	1382.0	1266.0					44.5	2496.5	2380.5	

Footnote: The radial thickness of the insulation of cores with diameters of 0.5 and 0.7 mm for a twisted pair is 0.3 and 0.4 mm respectively; and for a quadded (spiral quad) formation, 0.25 and 0.3 mm.

Key: 1. Jacket; 2. Unarmored cable; 3. Outside diameter, mm; 4. Weight, Kg/Km; 5. Protective cover; 6. Cushion (radial thickness, 1.5 mm); 7. Armor; 8. Material and shape; 9. Size, mm; 10. Outer cover (radial thickness, 2.0 mm); 11. Outside diameter, mm; 12. Three layers of bitumen, between which there are the following layers: one of impregnated cable paper and one of impregnated cable yarn (jute); 13. Two layers of bitumen, between which there is a layer of impregnated cable yarn (jute); 14. Radial thickness, mm.

TABLE 3.30. Basic Wire Characteristics

Copper		Aluminum		Galvanized Steel	
Specific Weight g/cm <sup>3</sup>	Specific Resistance Ohm·mm <sup>2</sup> /m	Specific Weight g/cm <sup>3</sup>	Specific Resistance Ohm·mm <sup>2</sup> /m	Specific Weight g/cm <sup>3</sup>	Specific Resistance Ohm·mm <sup>2</sup> /m
8.89	0.01724	2.7	0.0280	7.8	0.18 - 0.22

TABLE 3.31. The Weight of 1 Km of Wire of different Diameters

Диаметр мм Diameter, mm		0,5	0,6	0,7	0,8	0,9	1,0	1,1	1,15	1,2	1,4	1,55
Weight Масса кг Kg	медь Copper	1,75	2,52	3,43	4,48	5,67	7,00	8,47	—	10,08	13,70	—
	алю- миний Aluminum	0,53	—	1,04	—	1,73	2,12	2,56	2,78	3,06	4,16	5,09

Polyethylene (PET) belongs to the group of thermoplastic materials, and burns slowly with a bluish flame without soot. It is used as a high frequency dielectric and is produced in two variants: high pressure (VD) and low pressure (ND) polyethylene. The basic characteristics of high pressure and low pressure polyethylene are given in Table 3.33.

Porous polyethylene is a solid dielectric containing a large number of closed pores. The degree of porosity fluctuates from 35 to 50 percent.

The basic characteristics of porous polyethylene are shown in Table 3.34.

Telephone paper is used as insulation for the cores in multipair cables with lead jacketing. The paper type is designated by the letters KT (cable, telephone) with the addition of a symbol for the color: KTK - red, KTS - blue, KTZ - green, and KTN - natural. Telephone paper is manufactured without adhesive, with a thickness of 0.05 mm and has a standard width of 500 ± 10 mm.

Cable paper is used for winding the cable core and is manufactured with thicknesses of 0.08, 0.12 and 0.17 mm, which corresponds to the types K-80, K-120 and K-170.

The basic characteristics of telephone and cable paper are given in Table 3.35.

Paper cording is paper yarn wound on a core and maintains a constant air gap between the core and the paper winding. Insulating cord is used in the following diameters: 0.40 ± 0.02, 0.50 ± 0.03, 0.60 ± 0.03, 0.76 ± 0.04, 0.85 ± 0.04 mm. The cord should have a constant diameter over its entire length.

TABLE 3.32. The Basic Characteristics of Polyvinylchloride Plastic

Property	Unit of Measurement	Prescriptions					Рецептуры			
		1. изоляционные					2. шланговые			
Характеристика	Единица измерения	489	111	тепло-стойкая	230, 251	38	948	239, 288	301	1183, 355
4. Удельная масса	г/см <sup>3</sup>	1,36	1,30	1,34	1,31	1,32	1,21	1,3	1,3	1,26
5. Временное сопротивление при разрыве	кгс/мм <sup>2</sup>	200÷250	180÷220	200÷250	180÷230	130÷160	100÷120	160÷180	150÷165	120÷130
6. Относительное удлинение при разрыве	%	230÷260	210÷270	200÷220	200÷280	220÷240	320÷400	280÷300	280÷310	300÷400
7. Морозостойкость	°C	-50	-40	-15	-40	-15	-55	-40	-50	-60
8. Влапоглощаемость за 30 суток	%	0,25÷0,4	0,6÷0,8	0,2÷0,4	0,7÷0,9	0,2÷0,3	1,0÷1,2	0,7÷0,9	1,0÷1,2	1,0÷1,2
9. Коэффициент влагопроницаемости	г/см·ч·мм рт. ст.	—	$(1\frac{-3}{-3}) \times 10^{-8}$	$(1\frac{-3}{-3}) \times 10^{-8}$	$(1\frac{-3}{-3}) \times 10^{-8}$	$(1\frac{-3}{-3}) \times 10^{-8}$	$(1\frac{-3}{-3}) \times 10^{-8}$	$(3\frac{-5}{-5}) \times 10^{-8}$	$(3\frac{-5}{-5}) \times 10^{-8}$	$(3\frac{-5}{-5}) \times 10^{-8}$
10. Температура разложения	°C	240÷260	240÷250	240÷250	220÷250	170÷195	220÷240	220÷250	220÷250	220÷240
11. Температура размягчения	°C	180÷185	170÷175	180÷190	175÷180	150÷160	160÷170	170÷175	170÷175	160÷170
12. Удельное объемное сопротивление при +20°C	Ом·см	$(2\frac{-5}{-5}) \times 10^{13}$	$1 \cdot 10^{14}$	$5 \cdot 10^{14}$	$(1\frac{-3}{-3}) \times 10^{13}$	$(1\frac{-3}{-3}) \times 10^{13}$	$1 \cdot 10^{12}$	$(4\frac{-7}{-7}) \times 10^{11}$	$(2\frac{-5}{-5}) \times 10^{11}$	$(5\frac{-7}{-7}) \times 10^{11}$
13. Тангенс угла диэлектрических потерь при частоте 1000 Гц	—	—	0,04	0,02	0,07	0,09÷0,1	—	0,07	0,13	—
14. Диэлектрическая проницаемость при частоте 1000 Гц	—	4÷5	4÷5	3,5÷4,0	5÷6	4÷6	—	6÷6,6	6÷7	—
15. Электрическая прочность при частоте 50 Гц	кВ/мм	50÷60	50÷60	50÷60	50÷60	—	—	35÷50	—	—

Key: 1. Insulation type; 2. Tubing type; 3. Heat resistant; 4. Specific weight; 5. Resistance to rupture; 6. Relative elongation at rupture; 7. Resistance to cold; 8. Moisture absorption capability over 30 days; 9. Moisture permeability factor; 10. Decomposition temperature; 11. Softening temperature; 12. Specific volumetric resistance at +20° C; 13. Tangent of the dielectric phase angle at a frequency of 1,000 Hz; 14. Dielectric constant at a frequency of 1,000 Hz; 15. Electrical strength at a frequency of 50 Hz; 16. g/cm<sup>3</sup>; 17. Kg/mm<sup>2</sup>; 18. g/cm<sup>3</sup>·hr mm Hg.

TABLE 3.33. Basic Characteristics of High and Low Pressure Polyethylene

Characteristic	Unit of Measurement	High Pressure	Low Pressure
Specific weight	g/cm <sup>3</sup>	0.92	0.93 - 0.96
Moisture absorption capability over 30 days	%	0.01	0.01
Moisture permeability factor	g/cm·hr mm Hg	2 · 10 <sup>-9</sup>	2 · 10 <sup>-9</sup>
Softening temperature	° C	105 - 115	140 - 150
Freeze resistance	° C	-50 - -55	-50 - -60
Temperature coefficient of expansions	1/° C	(2 - 8) · 10 <sup>-4</sup>	1.3 · 10 <sup>-4</sup>
Resistance to rupture	Kg/mm <sup>2</sup>	1.0 - 1.5	2.0 - 2.4
Relative elongation at rupture	%	150 - 500	200 - 700
Specific volumetric resistance	Ohm·cm	10 <sup>17</sup>	10 <sup>17</sup>
Dielectric permeability at a frequency of 10 <sup>6</sup> Hz	-	2.3	2.3
Tangent of the dielectric phase angle at a frequency of 10 <sup>6</sup> Hz	-	(3 - 5) · 10 <sup>-4</sup>	(3 - 5) · 10 <sup>-4</sup>
Electrical strength at a frequency of 50 Hz for thicknesses of 1 - 2 mm	Kv/mm	24 - 40	24 - 40

TABLE 3.34. Basic Characteristics of Porous Polyethylene

Characteristic	Unit of Measurement	Magnitude
Specific weight	g/cm <sup>3</sup>	0.47
Resistance to rupture	Kg/mm <sup>2</sup>	0.25 - 0.50
Relative elongation at rupture	%	300
Dielectric constant at a frequency of 10 <sup>6</sup> Hz	-	1.48
Tangent of the dielectric phase angle at a frequency of 10 <sup>6</sup> Hz	-	0.0005
Electrical strength at a frequency of 50 Hz for a thickness of 3.2 mm	Kv/mm	8.7



TABLE 3.35. Basic Characteristics of Telephone and Cable Paper

Характеристика Property	1. Единица измерения	Brand of Марка бумаги Paper			
		КТ KT	К-80	К-120	К-170
Толщина Thickness	мм mm	0,05	0,08	0,12	0,17
Отклонение по толщине Deviation in Thickness	мм	±0,0025	±0,005	±0,007	±0,01
Удельная масса Specific Weight	г/см <sup>3</sup> g/cm <sup>3</sup>	no more than 0,82 не более 0,82 не менее 0,70 no less than 0.70			
2. Относительное удлинение при разрыве, не менее, в направлении: 3. продольном 4. поперечном	%	4,0	20	6,0	—
5. Количество двойных перегибов, не менее	—	500	—	2000	—
Влажность Humidity	%	7±1	—	8	—
6. Диэлектрическая проницаемость при частоте 1000 Гц	—	1,97÷2,10	—	2,36÷2,82	—
7. Тангенс угла диэлектрических потерь при частоте 1000 Гц	—	—	—	5·10 <sup>-3</sup>	—

Key: 1. Unit of measurement; 2. Relative elongation at rupture, no less than; 3. In a longitudinal direction; 4. In a transverse direction; 5. Number of double reverse bends, no less than; 6. Dielectric constant at a frequency of 1,000 Hz; 7. Tangent of the dielectric phase angle at a frequency of 1,000 Hz.

To increase the mechanical strength, a cord is used which is twisted from two filaments with a twisting pitch of 3.5 - 7.0 mm. The resistance to rupture of the cord should be no less than 6.5 Kg/mm<sup>2</sup>.

Aluminum, steel and copper tapes are employed as shielding for cables, the characteristics of which are given in Table 3.36.

Sometimes, steel braid with a wire diameter of 0.3 - 0.5 mm is used. The density of the weave is 85 - 95 percent, and the angle at which the wires are run is 40 - 50°.

The jackets of multipair cables can be metallic (lead and aluminum) and plastic.

TABLE 3.36. Basic Characteristics of Shielding Tapes

Property Характеристика	Единица измерения 1.	Алюминиевая лента 2.	Медная лента 3.	Стальная лента 4.
Марка Type	—	М—мягкая (отожженная), Т—твердая (неотожженная)	МГМ—голая мягкая (отож- женная), МГТ—голая твердая (неотожжен- ная)	8. 9.
Thickness Толщина	мм	0,10±0,15 (+0,005 -0,01)	0,1+0,25× ×(±0,01)	0,05±0,2 × ×(±0,01)
Width Ширина	мм	10±25 (±0,25)	10±25 (0,13)	10±15 (±0,5)
5. Временное сопротив- ление разрыву	кгс/мм <sup>2</sup>	3 for M 3—для М 10—для Т	30 for MGT 30 для МГТ	28
6. Относительное удли- нение	%	3—для М	—	20
7. Удельная масса	г/см <sup>2</sup>	2,7	8,9	7,8

Footnotes: 1) The relative elongation is not standardized for type T copper and aluminum;  
2) The resistance to rupture is not standardized for MGT copper.

Key: 1. Unit of measurement; 2. Aluminum tape; 3. Copper tape;  
4. Steel tape; 5. Resistance to rupture in Kg/mm<sup>2</sup>; 6. Relative elongation in percent; 7. Specific weight in g/cm<sup>2</sup>; 8. MGM: bare, soft (annealed); 9. MGT: bare, hard (nonannealed).  
M = soft (annealed); T = hard (nonannealed).

TABLE 3.37. Lead Jacket Thickness

1. Диаметр кабеля под оболочкой, мм	2. Толщина оболочки кабеля, мм		
	without без брони armor	3. ленточной (Б) и плоской проволочной (П)	4. круглой проволочной (К)
Up to 9			—
До 9	1,2	1,1	
9÷13	1,3	1,15	1,9
13÷16	1,4	1,2	1,9
16÷20	1,5	1,25	2,0
20÷23	1,6	1,3	2,0
23÷26	1,7	1,4	2,0
26÷29	1,8	1,5	2,1
29÷32	1,9	1,6	2,2

Key: 1. Diameter of the cable under the jacket, mm; 2. Thickness of the cable jacket, mm; 3. Of the tape (B) and flat wire (T) type;  
4. Of the circular wire (K) type.

TABLE 3.38. Aluminum Jacket Thickness

1.	Диаметр кабеля под оболочкой, мм	До 13	13÷16	16÷20	20÷23	23÷26	26÷30	30÷33
2.	Толщина оболочки, мм	1,1	1,1	1,2	1,3	1,4	1,4	1,4

Key: 1. Cable diameter beneath the jacket, mm; 2. Jacket thickness, mm.

TABLE 3.39. Thickness of Polyvinylchloride and Polyethylene Jackets

1.	Диаметр кабеля под оболочкой, мм	4÷6	6÷8	8÷11	11÷14	14÷17	17÷22
	Jacket Thickness, in mm	0.6	0.9	1.2	1.5	1.7	1.9

Key: 1. Cable diameter beneath the jacket, mm.

TABLE 3.40 The Main Characteristics of Cable Jackets

Characteristic	Unit of Measurement	Lead	Aluminum	Polyvinylchloride	Polyethylene
Melting point	° C	+ 327	+ 658	-	+ 120
Specific weight	g/cm <sup>3</sup>	11.4	2.7	1.3	0.92
Resistance to rupture	Kg/cm <sup>2</sup>	2.0 - 2.5	4 - 5	1.6-1.8	1.2-1.4
Relative elongation at rupture	%	25 - 35	20 - 35	280-380	150-600
Specific electrical resistance	Ohm·mm <sup>2</sup> /m	0.221	0.028	(3-7)·10 <sup>15</sup>	1·10 <sup>21</sup>

TABLE 3.41. The Main Characteristics of Armor

Characteristic	Unit of Measurement	Armor Tape	Armor Wire
Thickness	mm	0.3 - 1	-
Width	mm	15 - 60	-
Diameter	mm	-	1 - 8
Resistance to rupture	Kg/mm <sup>2</sup>	30	35 - 50
Relative elongation	%	20	8 - 12

Used for lead jackets is lead of the S-3 type with a purity of 99.9%, having antimony added in the amount of 0.4 - 0.8%, or tin in the amount of 1 - 3%.

The thickness of the lead jacket depends on the diameter of the core and the type of protective cover (Table 3.37).

The approximate thickness of an aluminum jacket is given in Table 3.38.

The thickness of plastic jackets depends on the diameter of the cable core, and is given in Table 3.39.

The main characteristics of cables jackets of lead, aluminum, polyvinyl chloride and polyethylene are given in Table 3.40.

Protective covers, consisting of cushions, armor and an exterior cover, are used for the mechanical protection of the cable against external actions. Depending on the function of the cable, either steel armor tape, circular or flat armor wire (Table 3.41) is used for armoring them.

Cable yarn (jute) is used a cushion, which is applied to the jacket underneath and above the armor (the outer cover). The yarn consists of a mixture of hemp fibers, linen fibers, etc.

Unrefined residual axle grease and bitumen are used for impregnating the protective covers (of cable yarn and paper). Unrefined residual axle grease is a thick oily liquid with a specific gravity of 0.926 - 0.936 g/cm<sup>3</sup>. Bitumen is a solid, relatively brittle black colored mass with a specific gravity of 1 g/cm<sup>3</sup>. The most widely used is No. 3 low melting point bitumen with a softening temperature of + 50° C, as well as No. 4 and No. 5 high melting point bitumens with softening temperatures of + 70° C and + 90° C respectively.

The dimensions of the protective covers (of the armor, cushioning, and outer covers) are given in Table 3.42.

TABLE 3.42. Dimensions of the Elements of Protective Covers

The Diameter of the Cable at the Jacket  Диаметр кабеля по оболочке, мм	1. Радиальная толщина				Of the Outside наружного покрова Cover
	2. подушки, не менее				
	3. под стальными лентами		4. под оцинкованными стальными прово- локами		
	5. нормальная	6. усиленная	5. нормальная	6. усиленная	
Up to 13 До 13	1,5	2	—	—	2
13-37	«	«	2	2,5	«
37-50	«	«	«	«	«
More than Свыше 50	«	«	«	«	«

Key: 1. Radial thickness; 2. Of the cushion, no less than; 3. Under the steel tapes; 4. Under galvanized steel wires; 5. Standard; 6. Reinforced.

## The Electrical Characteristics of Cable Circuits

The transmission parameters include primary and secondary parameters.

Included in the primary parameters of communications cables are the resistance, inductance, capacitance and conductivity.

The active AC resistance of a cable circuit up to 5,000 Hz is determined from the expression:

$$R = R_o + R_{se} + R_{pe} + R_1 \quad (3.32)$$

where  $R_o$  is the DC resistance;  
 $R_{se}$  is the resistance due to the skin effect;  
 $R_{pe}$  is the resistance due to the proximity effect;  
 $R_1$  is the resistance due to losses in the metallic parts of the cable structure (adjacent cable pairs, shield, and jacket).

The DC resistance is determined from formula (3.3) taking into account the twist factor,  $\kappa$ , which determines the increase in the resistance of the circuit due to the twisting of the wires.

The values of the twist factor are given in Table 3.43 as a function of the diameter of the lay.

TABLE 3.43. The Twist Factor

Диаметр повива, мм Diameter of the Lay	До 30	30÷40	40÷50	50÷60	60÷70	70÷80
Кoeffициент укрутки Twist factor	1,010	1,016	1,025	1,037	1,050	1,070

The twist factor for the cores of single quadded cables can be taken as 1.01, and for single pair cables, 1.0. The values of the DC resistances of copper two wire cable circuits, without taking the twist into account, at a temperature of +20° C are given in Table 3.44.

TABLE 3.44. The DC resistance of a Copper Circuit

1.	Диаметр жил мм	0,5	0,6	0,7	0,8	0,9	1,0	1,2	1,4
2.	Сопротивление Ом/км	175,6	122,0	89,6	68,6	54,2	43,9	30,5	22,4

Key: 1. Diameter of the cores, mm; 2. Resistance, Ohm/Km.

Cable circuits with aluminum cores having diameters of 0.65, 1.0, 1.2, 1.6 and 1.8 mm have active resistances practically equal to the resistances of copper core circuits having diameters of 0.5, 0.8, 1.0, 1.2 and 1.4 mm respectively.

The calculation of the resistance of cable cores at a temperature other than +20° C ( $R_t$ ), is calculated from formula (3.4).

The average value of the temperature coefficient of the DC resistance ( $\alpha_{R_0}$ ) in a temperature range of from 0 to 100° C for copper and aluminum cable cores can be taken as equal to 0.004/1° C. The temperature coefficient of resistance for AC in the high frequency range, due to the skin effect, is approximately equal to:

The ratio  $R_t/R_{20}$  for copper and aluminum cable cores is given in Table 3.45.

TABLE 3.45. The Ratio  $R_t/R_{20}$  for Copper and Aluminum Cores

$t^\circ\text{C}$	+50	+45	40	+35	+30	+25	+20	+15	+10
$R_t/R_{20}$	1,12	1,10	1,08	1,06	1,04	1,02	1,00	0,98	0,96
$t^\circ\text{C}$	+5	0	-5	-10	-15	-20	-25	-30	-35
$R_t/R_{20}$	0,94	0,92	0,90	0,88	0,86	0,84	0,82	0,80	0,78

The active AC resistance of a cable circuit at frequencies above 5,000 Hz, without considering the influence of a shielding element, is determined from the expression

$$R_{\sim} = R_t \left[ 1 + F(x) + \frac{pG(x) \left(\frac{d_0}{a}\right)^2}{1 - H(x) \left(\frac{d_0}{a}\right)^2} \right] \quad (3.33)$$

In this formula, the first term takes into account the DC resistance, the second one, the resistance due to the skin effect, and the third one, the resistance due to the proximity effect.

$R_t$  is the DC resistance of the cable circuit at a temperature,  $t^\circ\text{C}$ , other than 20° C;

$a$  is the spacing between core centers, in mm;

$d_0$  is the diameter of a core, mm;

$p$  is a coefficient taking into account the form of the twist, the value of which is given in Table 3.46.

TABLE 3.46. The p Coefficient for Different Twist Configurations

Twist	Type of Circuit	Coefficient
Pair	Main	1
Spiral quad	Main	5
	Artificial	1.6

F(x), G(x) and H(x) are functions which depend on the coefficient for the eddy currents and the core diameter  $d_0$  (determined from Table 3.21).

At frequencies of 30 KHz and above, the losses in the metallic jacket and adjacent elements of the cable,  $R_m$ , are taken into account. For a lead jacket, these losses are determined from the expression:

$$R_m \text{ lead} = \quad (3.34)$$

where f is the frequency in Hz;  $R'_m$  is an additional resistance resulting from the adjacent quads and the lead jacket of the cable, which is given in Table 3.47 for a frequency of 200 Hz.

Table 3.47. Values of the Quantity  $R'_m$

Number Число четверок of Quads	1. Сопротивление, Ом, вызываемое							
	2. соседними четверками				3. свинцовой оболочкой			
	4. повивы							
	1	2	3	4	1	2	3	4
1	0	—	—	—	2,2	—	—	—
1+6	8	7,5	—	—	1,5	5,5	—	—
1+6+12	8	7,5	7,5	—	0	0	1,0	—
1+6+12+17	8	7,5	7,5	7,5	0	0	0	1,0

Key: 1. Resistance in ohms, caused by;; 2. Adjacent quads; 3. The lead jacket; 4. Lays.

The loss resistance ( $R_m$ ) for a non-lead, as well as for any other metallic jacket of a cable, is determined from the formula:

$$R_m = R_{m \text{ CB}} \sqrt{\frac{\rho}{\rho_{\text{CB}}}} \approx 2,12_{\text{м CB}} \sqrt{\rho}, \text{ Ом/км}, \quad (3.35)$$

where  $R_{m \text{ CB}}$  is the additional resistance with the presence of a lead jacket computed from formula (3.34) in Ohms/Km;  $\rho$  is the specific electrical resistance of the jacket metal, Ohms·mm<sup>2</sup>/m.

The inductance of a cable circuit,  $L$ , consists of the external interconductor inductance,  $L_H$ , which depends on the diameter of the cores and the spacing between their centers, and the internal inductance,  $L_B$ , determined by the magnetic field arising within the conductor. The inductance of a two-wire circuit is determined taking the twist factor into account:

$$L = L_H + L_B = \kappa \left[ 4 \ln \frac{2a - d_0}{d_0} + \mu Q(x) \right] 10^{-4} \quad (3.36)$$

where  $\mu$  is the magnetic permeability of the conductor metal;  
 $Q(x)$  are the functions determined from Table 3.21.

The external inductance has the greatest value, since the internal inductance is significantly smaller in absolute magnitude, and decreases substantially with an increase in frequency.

The inductance of an artificial circuit formed from a spiral quad, is 1.4 times less than the inductance of a main circuit.

The capacitance of a cable circuit,  $C$ , is:

$$C = \frac{\kappa \epsilon 10^{-6}}{36 \ln \left( \frac{2a}{d_0} \psi \right)} \quad (3.37)$$

where  $\kappa$  is the twist factor;  
 $\bar{\epsilon}$  is the equivalent dielectric constant for the combined insulation;  
 $a$  is the spacing between the centers of the cores, mm;  
 $d_0$  is the core diameter, mm;  
 $\psi$  is the correction factor, characterizing the proximity of the cable circuit to the grounded jacket and other cores, the value of which is given in Table 3.48 for various twist configurations;  
 $d$  is the diameter of an insulated core, mm.

TABLE 3.48.  
 The Coefficient for Different  
 Twist Configurations

$d_1/d_0$	1. Парная скрутка	2. Звездная скрутка
1,6	0,608	0,588
1,8	0,627	0,611
2,0	0,644	0,619
2,2	0,655	0,630
2,4	0,665	0,647

Key: 1. Pair twist;  
 2. Spiral quad.

The equivalent dielectric constant depends on the type of insulation and the ratio of the dielectrics in the cable insulation. For combined insulation (solid dielectric and air), the equivalent dielectric factor is determined by the expression:

$$\epsilon = \frac{\epsilon_1 V_1 + \epsilon_2 V_2}{V_1 + V_2} \quad (3.38)$$

where  $\epsilon_1$  and  $\epsilon_2$  are the dielectric constants for the first and second dielectrics respectively;



$V_1$  and  $V_2$  are the volumes of the first and second dielectrics respectively.

Since communications cables, as a rule, have continuous insulation which is the same over the length, it is possible to substitute the ratio of the cross sectional areas for the ratio of the volumes in the given formulas:

$$\epsilon = \frac{\epsilon_1 S_1 + \epsilon_2 S_2}{S_1 + S_2} \quad (3.39)$$

where  $S_1$  and  $S_2$  are the cross sectional areas of the first and second dielectrics respectively.

For a radially combined (two layer) insulation, the equivalent dielectric constant will be equal to:

$$\epsilon = \frac{\epsilon_1 \epsilon_2 \ln \frac{d_2}{d_0}}{\epsilon_1 \ln \frac{d_2}{d_1} + \epsilon_2 \ln \frac{d_1}{d_0}} \quad (3.40)$$

where  $d_0$  is the diameter of a core, mm;  
 $d_1$  and  $d_2$  are the diameters of the insulated core through the first and second insulation layers respectively, mm.

TABLE 3.49.

The Dielectric Constant for Different Types of Insulation

Type of Insulation	Dielectric Constant
Paper mass	1.6 - 1.7
Air - Paper	1.5 - 1.6
Paper cord	1.4 - 1.6
Polyethylene	1.9 - 2.1
Porous polyethylene	1.4 - 1.5

The values for the equivalent dielectric constant for different insulation types are given in Table 3.49.

The capacitance of an artificial circuit formed from a spiral quad is 2.7 times greater than the capacitance of the main circuit.

The capacitance of single pair cables with two layer insulation is determined from formulas (3.40) and (3.43):

$$C \approx \frac{\epsilon_1 \epsilon_2 10^{-6}}{36 \left( \epsilon_1 \ln \frac{d_2}{d_1} + \epsilon_2 \ln \frac{d_1}{d_0} \right)} \quad (3.41)$$

The conductivity of the insulation of a cable circuit,  $G$ , is determined from a formula similar to formula (3.12):

$$G = G_0 + G_f \quad (3.42)$$

where  $G_0 = 1/R_{ins}$  is the insulation conductivity for direct current, mhos/Km;  
 $G_f = \omega C \tan \delta$  is the conductivity of the insulation caused by dielectric losses with alternating current, mhos/Km;  
 $R_{ins}$  is the insulation resistance of the cable circuit, Ohms·Km; [sic]  
 $\omega = 2\pi f$  is the angular frequency in radians;  
 $f$  is the frequency in Hz;  
 $C$  is the capacitance of the cable circuit, Fd/Km;

$\operatorname{tg} \delta$  [ $\tan \delta$ ] is the tangent of the dielectric loss angle.

The insulation resistance of cables is determined from the formula:

$$R_{\text{ins}} = R_{\text{из}} = \rho \frac{10^{-11}}{2\pi} \ln \frac{d_1}{d_0} \quad (3.43)$$

where  $\rho$  is the specific resistivity of the dielectric, Ohms·cm;

$d_0$  is the diameter of a core, mm;

$d_1$  is the diameter of an insulated core, mm.

The insulation resistance of a cable at a temperature other than + 20° C, is determined from the formula

$$R_{\text{ins } t} = \frac{R_{\text{ins } 20}}{k} \quad (3.44)$$

Where  $R_{\text{ins } t}$  is the insulation resistance at a temperature  $t^\circ$  C, Ohms·Km;

$R_{\text{ins } 20}$  is the insulation resistance at a temperature of + 20° C, Ohms·Km;

$k$  is the conversion factor, the value of which is given in Table 3.50 for different insulations.

TABLE 3.50. The Conversion Factor  $k$

1. Тип изоляции	Temperature    Температура, °C    °C												
	-20	-15	-10	-5	0	+5	+10	+15	+20	+25	+30	+35	+40
2. Бумажная	0,06	0,10	0,17	0,25	0,35	0,40	0,55	0,75	1,00	1,35	1,82	2,45	3,33
3. Поливинилхлоридная	0,001	0,003	0,08	0,02	0,05	0,1	0,2	0,5	1,0	2,2	4,6	8,8	16,7

Footnote: For polyethylene insulation, the factor  $k$  is practically equal to 1.

Key: 1. Type of insulation; 2. Paper; 3. Polyvinylchloride

The quantity  $G_0$  is significantly less than  $G_f$  in cables, and for this reason one can assume:

$$G \approx G_f = \omega C \operatorname{tg} \delta \quad (3.45)$$

where  $\operatorname{tg} \delta$  is the equivalent tangent of the dielectric loss angle for the combined insulation.

The quantity  $\operatorname{tg} \delta$  for cables with mixed combination insulation depends on the ratio of the dielectrics and taking into account the uniformity of the insulation over the communications cable length is equal to:

$$\operatorname{tg} \delta = \frac{\epsilon_1 \operatorname{tg} \delta_1 S_1 + \epsilon_2 \operatorname{tg} \delta_2 S_2}{\epsilon_1 S_1 + \epsilon_2 S_2}$$

where  $\epsilon_1$  and  $\epsilon_2$  are the dielectric constants of the first and second dielectrics respectively;  $\text{tg}\delta_1$  and  $\text{tg}\delta_2$  are the tangents of the dielectric loss angles for the first and second dielectrics respectively;  $S_1$  and  $S_2$  are the cross sectional areas of the first and second dielectrics respectively.

The equivalent values of the tangent of the dielectric loss angles for cables with different insulations are given in Table 3.51.

TABLE 3.51. The Value of  $\tan \delta \cdot 10^{-4}$  for Different Types of Insulation

Тип изоляции Type of Insulation	Frequency Частота, кГц KHz.			
	10	100	250	550
1. Кордельно-бумажная	55	113	160	280
2. Сплошная полиэтиленовая	2	6	8	14
3. Пористо-полиэтиленовая	4	8	12	20

Key: 1. Paper-cord; 2. Solid polyethylene; 3. Porous polyethylene.

In shielded cable circuits, it is necessary to take the reactive effect of the shield into account in calculating  $R_1$ ,  $L$  and  $C$ . The active resistance of the shielded circuit is determined from the formula:

$$R = R_t \left[ 1 + F(x) + \frac{\rho G(x) \left(\frac{d_0}{a}\right)^2}{1 - H(x) \left(\frac{d_0}{a}\right)^2} \left(1 - 4 \frac{a^2 d_3^2}{d_3^4 - a^4}\right) \right] + R_s, \quad (3.46)$$

where  $d_\epsilon$  is the diameter of the shield in mm;  
 $r_\epsilon$  are the losses in the shield, in Ohms/Km.

The inductance of a shielded circuit can be expressed in terms of the inductance of the unshielded circuit,  $L_{un}$ , computed from formula (3.36), and the additional inductance,  $L_\epsilon$ , introduced by the shield:  $L = L_{un} + L_\epsilon$ :

$$L_s = \kappa \left[ 4 \ln \frac{d_3^2 - a^2}{d_3^2 + a^2} - 16 \frac{\mu \sqrt{2}}{x} \frac{a^2 d_3^2}{d_3^4 - a^4} \right] 10^{-4}, \quad (3.47)$$

where  $\kappa$  is the twist factor;  
 $\mu$  is the magnetic permeability of the shield material;  
 $\kappa = \sqrt{\omega \mu_a \sigma}$  is the eddy current coefficient, 1/mm;  
 $\sigma = 1/\rho$  is the specific electrical conductivity of the shield material, m/Ohms·mm<sup>2</sup>;  
 $\mu_a = \mu_0 \mu$  is the absolute magnetic permeability of the shield material, Hy/m;  
 $\mu_0 = 4\pi \cdot 10^{-7}$  is the magnetic constant, Hy/m.

The capacitance of a shielded circuit is determined from the formula:

$$C = \frac{\kappa \epsilon 10^{-6}}{36 \ln \frac{2a}{d_0} \frac{d_s^2 - a^2}{d_s^2 + a^2}} \quad (3.48)$$

where  $\epsilon$  is the equivalent dielectric constant of the insulation;

$\kappa$  is the twist factor;

$a$  is the spacing between the centers of the cores, mm;

$d_0$  is the diameter of a core, mm;

$d_s$  is the diameter of the shield, mm.

The primary parameters of single pair, single quadded and multipair cables are given in the appendix.

Included in the secondary transmission parameters are the attenuation and phase factors, the working attenuation and the characteristic impedance.

The attenuation factor  $\alpha$  and the phase factor  $\beta$ , as well as the propagation constant ( $\gamma = \alpha + i\beta$ ) and the wave (characteristic) impedance  $Z_B$  in the general form, depending on the primary transmission parameters, are determined from the formulas given in section 3.1.

One can use simplified formulas in individual frequency ranges:

-- For direct current:

$$\alpha = \sqrt{R_0 G_0} = \sqrt{\frac{R_0}{R_{H3}}}, \quad \beta = 0, \quad Z_B = \sqrt{\frac{R_0}{G_0}} = \sqrt{R_0 R_{H3}} \quad (3.49)$$

-- In the audio frequency range ( $f \approx 800$  Hz)

$$\alpha = \beta = \sqrt{\frac{\omega RC}{2}}, \quad Z_B = \sqrt{\frac{R}{\omega C}} e^{-i45^\circ} \quad (3.50)$$

-- In the high frequency range, where  $\frac{\omega L}{R} > 5$ , and  $\frac{\omega C}{G} > (f \geq 30 + 40 \text{ KHz})$  [sic]

$$\left. \begin{aligned} \alpha &= \frac{R}{2} \sqrt{\frac{C}{L}} + \frac{G}{2} \sqrt{\frac{L}{C}}, \\ \beta &= \omega \sqrt{LC} \\ Z_B &= \sqrt{\frac{L}{C}} \end{aligned} \right\} \quad (3.51)$$

The attenuation factor for a cable circuit at a temperature  $t^\circ \text{C}$  other than  $+20^\circ \text{C}$  is determined from the formula:

$$\alpha_t = \alpha_{20} [1 + \alpha_\alpha (t - 20)], \quad (3.52)$$

where  $\alpha_{20}$  is the attenuation factor at  $+20^\circ \text{C}$ , dB/Km (Nep/Km);

$t$  is the temperature at which the attenuation factor is specified, °C;  
 $\alpha_\alpha$  is the temperature coefficient of the attenuation, equal to the relative increase in attenuation per °C.

The working attenuation of a cable circuit,  $a_p$ , is the attenuation under actual conditions, i.e. for any loads at the ends of the circuit:

$$a_p = a + \ln \left| \frac{Z_0 + Z_B}{2\sqrt{Z_0 Z_B}} \right| + \ln \left| \frac{Z_1 + Z_B}{\sqrt{Z_1 Z_B}} \right| + \ln \left[ 1 - p_0 p_1 e^{-2\gamma l} \right] \quad (3.53)$$

where the first term is the inherent attenuation of the circuit, dB (Nep);  
the second term is the mismatch attenuation at the start of the circuit, dB (Nep);  
the third term is the mismatch attenuation at the end of the circuit, dB (Nep);  
the fourth term is the mismatch interaction, dB (Nep);  
 $Z_0$  and  $Z_1$  are the loads at the beginning and end of the circuit respectively, Ohms;  
 $p_0$  and  $p_1$  are the reflection factors at the beginning and end of the circuit, respectively, equal to:  $\frac{Z_0 - Z}{Z_0 + Z}$  and  $\frac{Z_1 - Z}{Z_1 + Z}$ ;

$\gamma$  is the circuit propagation constant;  
 $l$  is the length of the circuit, Km.

The input impedance of a cable circuit,  $Z_{BX}$ , is the impedance at the input of the circuit for any load at the end ( $Z_1 \neq Z_B$ ):

$$Z_{BX} = Z_B \operatorname{th}(\gamma l + n) \quad (3.54)$$

where  $Z_B$  is the characteristic impedance of the circuit, Ohms;  
 $n$  is equal to  $\frac{1}{2} \ln \frac{1}{p_l}$ .

With a change in the circuit length or the frequency of the signals being transmitted,  $Z_{BX}$  varies in accordance with an oscillatory law about the magnitude  $Z_c$ . For an electrically long line ( $\alpha l > 13.0$  dB [1.5 Nep]), the input impedance is always equal to the characteristic impedance ( $Z_{BX} = Z_B$ ).

The secondary transmission parameters of single pair, single quadded and multi-pair cables are given in the appendix.

The interfering influences between communications circuits are caused by the action of the electromagnetic field of the influencing circuits on the circuits subject to the influence, and are defined as the influence parameters.

The crosstalk attenuation and isolation of a short section between cable circuits, of an approximately equal structural length, are determined from formulas, which are given in nepers in accordance with the existing norms:

$$\left. \begin{aligned} A_0 &= \ln \left| \frac{2}{\kappa_0 Z_B} \right| \\ A_{0l} &= \ln \left| \frac{2}{\kappa_l Z_B} \right| \\ A_{3l} &= A_{0l} \end{aligned} \right\} \quad (3.55)$$

The crosstalk attenuations and the isolation for long cable lines are computed from the formulas:

$$\left. \begin{aligned} A_0 &= \ln \left| \frac{2 \sqrt{4\alpha l_S}}{\kappa_0 Z_B \sqrt{1 - e^{-4\alpha n l_S}}} \right| \\ A_{0l} &= \ln \left| \frac{2}{\kappa_l Z_B \sqrt{n}} \right| + \alpha n l_S \\ A_{3l} &= \ln \left| \frac{2}{\kappa_l Z_B \sqrt{n}} \right| \end{aligned} \right\} \quad (3.56)$$

The following symbols are introduced in formulas (3.55) and (3.56):

$k_0 = C + \frac{M}{Z_B}$  is the coefficient of electromagnetic coupling at the near end;

$k_1 = C - \frac{M}{Z_B}$  is the coefficient of electromagnetic coupling at the far end;

$C = g + i\omega c$  is the coefficient of electrical coupling;

$M = r + i\omega m$  is the coefficient of magnetic coupling;

$g$  is the active component of the electrical coupling, Mhos;

$c$  is the capacitive coupling, Fd;

$r$  is the active component of the magnetic coupling, Ohms;

$m$  is the inductive coupling;

$\omega = 2\pi f$  is the angular frequency;

$f$  is the frequency, Hz;

$\alpha$  is the attenuation factor of the circuit, dB/Km (Nep/Km);

$l_S$  is the structural length of the cable, Km;

$n$  is the number of structural lengths.

In all balanced cable circuits, the crosstalk attenuation and isolation decrease approximately logarithmically with an increase in frequency.

The transmission levels for power, voltage and current are the relative quantities, with which the absolute magnitudes of the corresponding parameters are replaced in various calculations, and are defined as the logarithm of the ratio of the magnitude of the corresponding parameter at the point of the circuit being considered to the magnitude adopted as the comparison one. The levels are expressed in Bels (decibels) when using base 10 logarithms, and in Nepers when using natural logarithms. The levels are:

$$\text{With respect to power: } p = \frac{1}{2} \ln \left( \frac{P_x}{P} \right),$$

$$\text{With respect to voltage: } p = \ln \left( \frac{U_x}{U} \right);$$

With respect to current:  $p = \ln \left( \frac{I_x}{I} \right)$ .

The absolute level of the power, voltage or current is defined as the logarithm of the ratio of these magnitudes at any point on the circuit to the magnitudes of 1 milliwatt, 0.775 volts and 1.29 milliamperes respectively.

The measurement level is an absolute level obtained at any point on the circuit, if a voltage at a level of 0 dB (Nep) is applied to its beginning.

The difference in the levels at the circuit points under consideration is equal to the attenuation of the section of the circuit joining these points:

$$p_1 - p_2 = \alpha l_{1,2}$$

where  $p_1$  is the level at the start of the section;  
 $p_2$  is the level at the end of the section;  
 $\alpha$  is the attenuation factor of the circuit, dB/Km (Nep/Km);  
 $l$  is the length of the circuit section, Km.

The parameters for the interaction of single quadded cables are given in Table 3.52.

One of the basic means of protecting cable circuits against noise is shielding them, which is accomplished by both shields and other metal elements of the cable structure, in particular, jacketing, armor, etc. The shielding elements of a cable simultaneously stabilize the electrical parameters of shielded cable circuits.

The shielding efficiency is defined as the coefficient of shielding, sometimes in the audio frequency range termed the coefficient of shield action or the coefficient of protective action (kzd):

$$S = \frac{H_e}{H} = \frac{E_e}{E} \quad (3.57)$$

where  $H_e$  and  $H$  are the magnetic field intensities inside the shielded space with the shield present and without it respectively;  
 $E_e$  and  $E$  are the electric field intensities inside the shielded space with the shield present and without it respectively.

At low frequencies, the influencing electromagnetic field is primarily compensated by the electromagnetic field produced by the longitudinal current induced in the metallic elements of the cable structure (in the jacket, armor, etc.).

Ideal or complete shielding can be achieved with a resistance to ground for the shielding element of zero, and in this case, the ideal shielding coefficient in the low frequency range will be:

$$S_H = \frac{R_0}{R_0 + i \omega L} \quad (3.58)$$

TABLE 3.52. The Interaction Parameters for Single Quadded Cables  
(For Structural Lengths)

Type of Cable Тип кабеля	Diameter of the Cores, mm Диаметр жил, мм	Frequency Частота тока KHz	Переходное затухание на ближнем конце дБ (Нп) 1.	Переходное затухание (защитенность) на дальнем конце дБ (Нп) 2.
ВТСП VTSP	1,2	0,8	100(11,5)	101(11,6)
		10	94(10,8)	97(11,2)
		30	85(9,8)	93(10,7)
		60	80(9,2)	89(10,2)
		76	78(9,0)	87(10,0)
		120	73(8,4)	83(9,6)
		250	73(8,4)	80(9,2)
		550	71(8,2)	73(8,4)
		600	70(8,1)	71(8,2)
		700	70(8,1)	69(8,0)
КСПП KSPP	0,9	0,8	105(12,1)	106(12,2)
		6,0	101(11,6)	105(11,5)
		10	96(11,0)	96(11,0)
		30	86(9,9)	89(10,2)
		60	85(9,8)	86(9,9)
		76	85(9,8)	83(9,6)
		120	85(9,8)	85(9,8)
		250	84(9,7)	82(9,4)
		300	82(9,4)	81(9,3)
		400	79(9,1)	80(9,2)
		550	79(9,1)	77(8,9)
		600	79(9,1)	76(8,7)
		700	76(8,8)	72(8,3)
		1000	73(8,4)	73(8,4)
		1500	70(8,1)	68(7,8)
2000	68(7,8)	64(7,4)		

Key: 1. Crosstalk attenuation at the near end, dB (Nep);  
2. Crosstalk attenuation (isolation) at the far end, dB (Nep).

Where  $R_0$  is the resulting DC resistance of the shielding elements, Ohms/Km;  
 $L$  is the inductance of the shielding element, Hy/Km.

For the case of a high frequency influencing electromagnetic field, the compensating electromagnetic field is created by eddy currents in the shielding elements. In this case, the shielding coefficient is determined from the formula:

$$S = S_{\pi} S_0 \quad (3.59)$$

where  $S_{\pi}$  is the coefficient of shield absorption, equal to:

$$S_{\pi} = \frac{1}{\operatorname{ch} \kappa t} \quad (3.60)$$



$S_0$  is the coefficient of shielding reflection, equal to:

$$S_0 = \frac{1}{1 + \frac{1}{2} \left( \frac{Z_\pi}{Z_M} + \frac{Z_M}{Z_\pi} \right) \text{th } \kappa t} \quad (3.61)$$

In these formulas:  $k = \sqrt{\omega \mu_0 \sigma}$  is the eddy current coefficient, 1/mm;  
 $t$  is the shielding element thickness, mm;

$$Z_d = \frac{i \omega \mu_a d_\epsilon}{2} \text{ is the characteristic impedance of the dielectric, Ohms;}$$

$$Z_M = \frac{\sqrt{i \omega \mu_a}}{\sigma} \text{ is the characteristic impedance of the metal, Ohms;}$$

$\sigma = 1/\rho$  is the specific conductivity of the material of the shielding element, Ohms·mm<sup>2</sup>/m;

$\rho$  is the specific resistance of the material of the shielding element, m/Ohms·mm<sup>2</sup>;

$\mu_a = \mu_0 \mu$  is the absolute magnetic permeability, Hy/m;

$\mu$  is the magnetic permeability;

$\mu_0 = 4\pi \cdot 10^{-7}$  is the magnetic constant, Hy/m;

$d_\epsilon$  is the diameter of the shielding element, mm;

$\omega = 2\pi f$  is the angular frequency;

$f$  is the frequency, Hz.

The greatest shielding effect is achieved by using multiple layer shields, for example, copper-steel-copper.

The shielding coefficient for multilayer shields is determined from the formulas:

For a two layer shield:

$$S_{1,2} = \frac{S_1 S_2}{1 - p_1 p_2} \quad (3.62)$$

For a three layer shield:

$$S_{1,2,3} = \frac{S_1 S_2 S_3}{(1 - p_1 p_2)(1 - p_2 p_3) - p_1 p_3 S_2^2} \quad (3.63)$$

In these formulas:  $S_1$ ,  $S_2$  and  $S_3$  are the shielding coefficients of the first, second and third layers respectively;  
 $p_1$ ,  $p_2$  and  $p_3$  are the coefficients for the reactive effect of the shields of the first, second and third layers respectively

### 3.3. CABLE LAYING AND INSTALLATION

The Organization of Construction Work

Single pair and single quadded rural telephone communications cables and multipair city type cables, primarily with plastic insulation and jacketing, are layed in rural terrain.

The following work operations are performed in the process of constructing cable lines:

- Preparation of the cable areas, the cable and the equipment;
- The preparation and surveying of the route;
- The construction of piping conduits for crossing roads;
- The transportation of structural materials for the route;
- The mechanized laying of the cables;
- Digging trenches and excavation pits;
- Manual cable laying;
- Filling in trenches and excavation pits;
- Setting up small gauging posts;
- Running cables through water barriers;
- Stringing cables on open wire line support poles;
- Trucking the empty reels away from the line;
- Structuring the feed-ins at amplifier and terminal points;
- Establishing the route on working drawings;
- Making electrical measurements of the layed out structural lengths;
- Installing splicing and junction boxes;
- Making check measurements of installed sections;
- Drawing up and completing the technical performance documentation.

The following production subdivisions should be organized for carrying out the operations enumerated above:

- Mechanized columns;
- Brigades for manually digging trenches and laying cable;
- Brigades for stringing cables on open wire line support poles;
- Installation brigades;
- A measurement group.

The number and composition of the production subdivisions enumerated above are determined by local conditions, the construction volumes and the deadlines for completing the work.

A mechanized column performs the following complex of operations:

- The preparation and clearing of the route;
- Supplying cable to the cable layer and trucking out the empty reels;
- Laying cable in the ground and through shallow waters with the cable layer;
- Establishing the terminal points of the structural lengths on the schematic;
- Setting up small marker posts.

The installation brigade does the following:

- Digs out excavations;
- Checks cables prior to installation;

- Installs junctions and coupling sleeves;
- Checks the quality of installation work;
- Fills in the excavation pits;
- Establishes the location points for the junctions on the route schematic.

The depth at which cables are buried on rural telephone communications lines should be no less than 0.8 m. The laying and installation of cables is permitted at an ambient air temperature of no less than  $-10^{\circ}$  C.

Single quadded and multipair cables are installed after being layed, while single pair ones are rigged both before and after laying. Before they are layed, single pair cables are rigged in sections at a permanent shop, where their length is determined by the amount of cable on the coils of the cable layers.

Single quadded cables are installed after laying the structural lengths over the entire amplifier section. The receiving and issuance of cable is documented for the installation work.

#### Preparation of the Route

The routes of cable lines are planned by working from the conditions of providing for the minimum lengths and maximum preservation of the cable. The routes are chosen along roads (between the road and the edge of a field). They should have a minimum number of intersections with railroads and highways, underground installations and electrical power transmission lines. On the routes, there should be no sections which have sewage waters, marsh gases, landslips, cave-ins, gullies, regions with intense swelling and cracking soil, or with massive rodent infestation.

The line routes should pass by other installations at a specified distance.

The norms for the proximity of cables to other installations are given in Table 3.53.

The joint laying of several single pair cables on subscriber telephone lines with a length of up to five kilometers is possible.

Subscriber telephone lines and radio repeater lines using single pair cables in one direction are run no closer together than at the following spacings

- For a radio network line voltage of up to 240 volts, 0.25 m;
- For a radio network line voltage greater than 240 volts, 1.0 m;

Cable line routes should be in accord with all of the organizations concerned (sovkhoses, kolkhoses, the administrations of railroads, highways and electrical power transmission lines), as well as with operating and engineering administration standards, RUS [expansion unknown], trunk cable line areas, and RCRM [expansion unknown].

The preparation of the route and marking it out over the terrain are carried out in strict accordance with the project plan documentation.

TABLE 3.53. Norms for the Proximity of Single Pair and Single Quadded Cables to Other Installations

Designation of the Other Installation	Permissible Spacing from Cables, m	
	Running Parallel	Intersecting
Power cables	0.5 in pipes	More than 0.25 in a pipe
Rural communications and radio network cables with a voltage up to 360 volts	0.5	The same
Radio network cables with a voltage greater than 360 volts	1.0	The same
Trunk line communications cables	Determined by the project plan	The same
Water line of the water distribution network, gas line with a pressure of up to 3 Kg/cm <sup>2</sup> or a water drain	1.0	More than 0.5 in pipes
Main line network water piping	2.0	The same
Gas line with a pressure of 3 to 10 Kg/cm <sup>2</sup>	10.0	The same
The grounds of open air communications lines	Determined by the project plan	
The Support poles of open air communications lines	Determined by the project plan	
Electrical power transmission lines support poles	Determined by the project plan	
Streetcar and railroad tracks	Determined by the project plan	1.0 from the rail bed
Highways	Determined by the project plan	0.8 below the bottom of the side drain

#### The Preparation of the Cable for Laying

Prior to laying, the structural lengths of the cables are checked. The cables are approved for laying only if they are not damaged and their electrical characteristics meet the norms.

The structural lengths of single quadded cables run over one amplified section are grouped together. The grouping is accomplished with respect to the cable structure, the length, the magnitude of the working capacitance of the circuits and the magnitude of the crosstalk attenuation at the near end, indicated in the data sheet for the structural lengths.

Grouping with respect to crosstalk attenuation is performed so that four to five structural lengths, which are run to the ends of an amplified section, have the greatest attenuation. Based on the results of the cable grouping, a laying report is drawn up, in which are recorded the numbers of the cable drums in the laying order. A number corresponding to the sequential number for the laying from the laying report is written on the end of each drum.

#### Mechanized Cable Laying

Single pair and single quadded cables on rural telephone communications lines are laid with light LKU-61 or LKU-61M cable layers. When laying two single quadded cables in one direction, LKU-61M or KU-120 cable layers are used.

TABLE 3.54. The Technical Characteristics of Cable Layers

Characteristic	Unit of Measurement	LKU-61	LKU-61M	KU-120
Number of tractors:				
S-100; S-80	Number	1 - 2	1 - 2	3 - 4
DT-54	Number	2 - 3	2 - 3	-
Nature of the ground in which laying is permitted	Classification	No greater than III	No greater than III	No greater than IV
Maximum cable diameter	mm	16.0	26.0	50.0
Maximum laying depth	m	0.8	1.2	1.2
Number of single quadded cables which can be laid simultaneously	Number	1	1 - 2	2
Weight	Tons	2	2.5	3.5
Cable laying speed	Km/hr	3 - 5	2.27 - 3.6	2.2
Towing speed behind a motor vehicle, no more than	Km/hr	30	30	30
Maximum traction force on the hook	Tons	10	10	60
Minimum turning radius	m	10	-	8
Number of service personnel	Persons	2	2	3

Multipair city type cables with an outside diameter of up to 50 mm are laid with the KU-120 cable layer. The technical characteristics of the cable layers are given in Table 3.54.

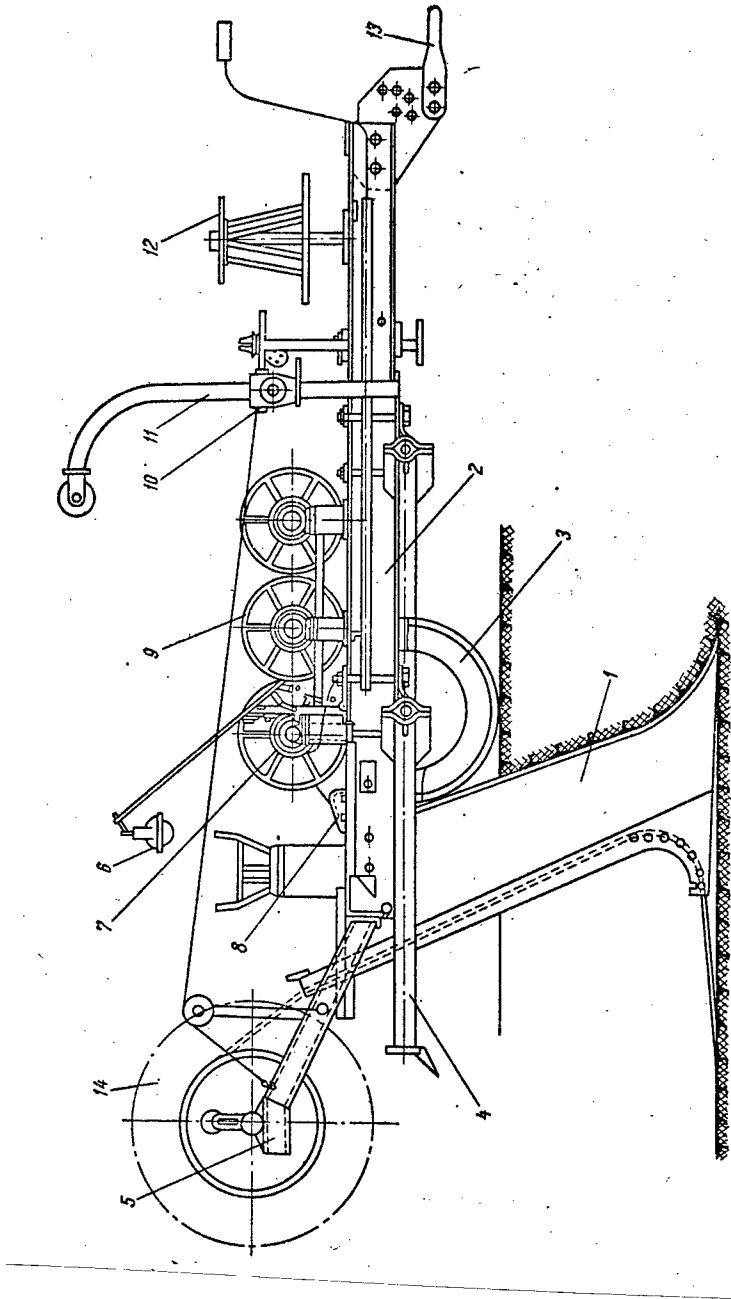

Figure 3.13. Drawing of the LKU-61 Cable Layer

- Key: 1. Blade; 2. Beam; 3. Running wheels; 4. Support; 5. Turning cantilever bracket;  
 6. Damper block; 7. Current pick-off; 8. Blade clamp; 9. Coil; 10. Manual winch;  
 11. Crane; 12. Cable drum carriage; 13. Coupling clevis; 14. Reel.

A drawing of the LKU-61M cable layer is shown in Figure 3.13.

Cable layers operate as towed devices behind S-100, S-80 or DT-54 tractors. The number of tractors is determined by the character and condition of the ground. When several tractors are used, the cable layer is hitched to the most powerful one.

#### Manual Cable Laying

A provision is made for laying cables manually in cases where it is impossible to use cable layers, for example, in difficultly passable regions, in constrained sections, at a branch network for underground installations, or when the use of cable layers is inexpedient due to the small volume of work.

TABLE 3.55. Trench Dimensions

Trench Depth, m	Trench Width, m	
	In Top Part	In Bottom Part
0.8	0.4	0.3
1.0	0.45	0.35
1.2	0.5	0.4

Note: When machines are used, the trench width is determined by the width of the working element of the digging machine.

Where possible when manually laying cables, the trenches and excavation pits should be dug out by machines (excavators, trenchers). The dimensions of trenches for laying single quadded or multipair cables are given in Table 3.55.

A 10 cm thick layer ("bed") of loose earth or sand is layed on the bottom of trenches in rocky soils. Single pair cables are layed from a cable drum carriage mounted on the motor vehicle, or carried manually, while single quadded and multipair cables are run from a cable carriage (for example, the KT-2), towed by a motor vehicle or tractor.

In the absence of a cable carriage, the drum with the cable is set up alongside the trench on sawhorses with lifting jacks, and the cable is unreeled and carried manually. In this case, one cannot permit the cable to be dragged along the ground. The cable is layed along the edge of the trench, inspected and then placed on the bottom. The cable is covered with loose soil without clods and stones, and is then covered over either manually or with a bulldozer. The filling-in is alternated with the tamping of the earth.

The position of the structural lengths is specified more precisely during the laying, and the positioning of their ends are marked on the drawings and on the terrain.

Where the routes cross railroads and highways, the ground is worked up in a concealed fashion, for example, using the BG-1 hydraulic drill, the DM-1 mechanism, or by other means. Concealed working of the ground, as well as digging out trenches at intersections with other underground installations, is carried out in the presence of the representatives of the organizations to which these installations belong, and concerning which they are notified well in advance.

Enough is left over at the beginning and terminating points of the structural lengths of the cables for their connection. The left over length is taken as 1.2 - 1.8 m for single pair and single quadded cables.

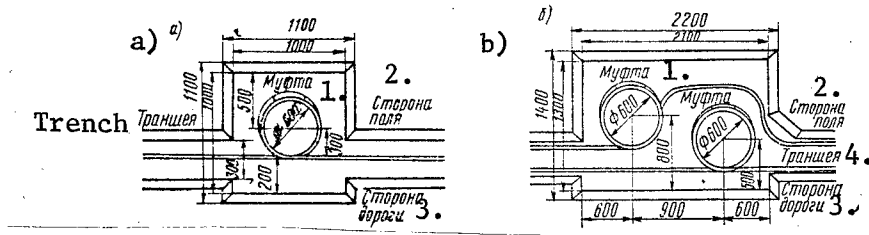

Figure 3.14. Dimensions of excavations.

- a) The excavations for one conduit coupling;
- b) The excavation for two conduit couplings;

Key: 1. Conduit coupling; 2. Field side; 3. Road side; 4. Trench.

Excavations are dug out for the connection of the structural lengths of the cables. The dimensions and shapes of the excavations for single quadded cables are shown in Figure 3.14.

#### Laying Cables in Telephone Conduit

Rural telephone network communications cables are run in telephone conduit (in an individual or already occupied conduit) in urban areas. In free conduits, the cables are pulled in by a 5 mm diameter steel wire or a steel cable, while in already occupied channels using hemp twine or rope. When laying multipair cables, the cable or rope is fastened to the steel cable grip attached to the cable. Single pair and single quadded cables are, as a rule, pulled in the conduit manually, while multipair ones are pulled in using winches. When laying cables with plastic jackets, the use of lubricants (technical vaseline) is not permitted.

The cable left over at inspection points should amount to 1.25 - 2.5 m.

Placed on the cable in each cable access manhole is a numeration ring, on which the number of the cable, its type, capacity and diameter of the cores is indicated.

#### Cable Stringing

Single quadded and multipair cables with a capacity, as a rule, of not more than 100 pairs are strung on open wire communications line support poles. The cables are secured to a 4.5 - 6.6 mm diameter galvanized steel cable by means of suspension hangers. The cable is fastened at angle brackets installed on the poles at a distance of 35 cm from the lower crossarm or hook. The



suspension hangers are spaced 35 cm apart. The distance from the support pole to the nearest suspension hanger should be no more than 17 cm. Below the angle brackets on the support poles, the cable is bent in an arc. No more than two cables are strung on one line, where they are positioned on opposite sides of the poles.

A provision is made for stringing cables at intersections only in the following cases:

- At intersections with water reservoirs up to 40 m wide;
- Over temporary bridges;
- Across railroad branches which are not electrified and are of secondary importance, where the number of tracks is no greater than two.

In the remaining cases, the cable crossings are made underground.

#### The Installation of Single Pair Cables

Prior to installing layed out cables, the continuity of the current carrying cores is checked and the insulation resistance is measured. Installation is permitted only in the case where the cables exhibit no damage and their insulation resistance is not below the norms.

TABLE 3.56. List of Tools and Accessories Used when Installing Single Pair Cables with Copper Cores

Tools and Accessories	Number	
	With Heating	Without Heating
Installation workbench	1	1
Electric soldering iron	1	1
Soldering iron, heated with a thermite muffle cartridge	1	1
Installer's knife	2	2
Sidecutters	2	2
Pliers	1	1
Tape measure	1	1
Small soft brush	1	1
Wooden spatula	1	1
Soldering torch	1	1
Tank for heating the junctions	1	-
Rubber gloves	1	1
Canvas gauntlets	1	-

Note: When installing cables with aluminum cores, used instead of a soldering iron is a holder for thermite muffle cartridges, with which the cores are welded underneath flux (wearing dark glasses)

Restoring the insulation covers of single pair cables when constructing rural telephone communications lines is accomplished using plastic tapes and chemical compounds, which require heating of the junctions at a temperature of + 105 - 107° C. Under operational conditions, the repair of the insulation covers of single pair cables is permitted using plastic tapes and adhesive compounds, which do not require the heating of the junctions (the cold working method). The list of tools and accessories required by one installation brigade for the installation of single pair cables is given in Table 3.56. Given in Table 3.57 is the list and consumption of installation materials required for making 10 direct junctions.

TABLE 3.57. Listing for and Consumption of Installation Materials  
(Figured for 10 Direct Connection Junctions of Single Pair Cables)

Материалы Materials	1. Едн- ица изме- рения	2. ПРВПМ ПТВЖ, ТРВК		ПРПВМ РРРВМ		ПРППМ 3. ПТПЖ	
		с про- гревом 4.	без про- грева 5.	с про- гревом 4.	без про- грева 5.	с про- гревом 4.	без про- грева 5.
6. Припой ПОС-40	г	4	4	4	4	4	4
7. Канифоль	г	2	2	2	2	2	2
8. Лента полиэтиленовая	г	—	—	25	25	25	25
9. Лента поливинилхлорид- ная	г	100	100	100	100	100	100
10. Смесь пластификатов	г	10	—	10	—	10	—
11. Перхлорвиниловый клей	г	—	100	—	100	—	—
12. Полиизобутиленовая мас- са	г	—	—	40	40	40	40
13. Лента I полиэтиленовая липкая	г	—	—	—	—	—	60
14. Изоляционная прорези- ненная х/б лента*)	г	5	—	5	—	5	—
15. Шпагат*)	г	3	—	3	—	3	—
16. Соль поваренная*)	кг	0,6	—	0,6	—	0,6	—
17. Вода*)	л	1,5	—	1,5	—	1,5	—
18. Бензин	л	2,0	0,1	2,0	0,1	2,0	0,1
19. Ветошь	г	20	20	20	20	20	20
20. Термитно-муфельные патроны	шт	11	11	11	11	11	11
21. Термоспички	шт	12	12	12	12	12	12
22. Мыло хозяйственное	г	50	100	50	100	50	50

Footnote: The materials marked with an asterisk are used repeatedly.

Key: 1. Unit of measurement; 2. PRVPM, PTVZh, TRVK; 3. PRPPM, PTPZh;  
4. With heating; 5. Without heating; 6. POS-40 solder, in grams;  
7. Rosin, in grams; 8. Polyethylene tape, in grams; 9. Polyvinyl-  
chloride tape, in grams; 10. Plastics mixture; 11. Perchlorovinyl  
glue, in grams; 12. Polyisobutylene paste, in grams; 13. Adhesive  
polyethylene tape, in grams; 14. Rubberized cotton insulation tape\*,  
in grams; 15. String\*, in grams; 16. Table salt\*, in Kg; 17. Water\*,  
in liters; 18. Gasoline, in liters; 19. Rags, in grams; 20. Thermite  
muffle cartridges, number; 21. Thermite starter matches, number;  
22. Household soap, in grams.

The ends of the cables which are cleaned of dirt have the insulation and jacketing removed (are stripped). The dimensions of the stripped sections should correspond to the sizes indicated in Table 3.58. Stripping single pair cables is accomplished using type KIVP-1 pliers or an installer's knife. The cleaned cores are positioned so that the long core is located opposite the short one. The cores are twisted with a minimum pitch. The cores which are twisted over a length of 25 mm are bent back perpendicular to the cable. The twists of copper and steel cores are soldered, while aluminum ones are welded or soldered, as shown in Table 3.59. The connection of current conducting cores with a simple twist (without soldering or welding) is not permitted. When working

TABLE 3.58. The Dimensions of Stripped Wire Sections

Тип кабеля 1.	Схема Configuration	Вид соединения 2	3. Размеры, мм							
			А	Б	В	Г	а	б	в	г
4. PRPPM с PRPPM PRPPM с PRPVM		Прямое 6	110	30	—	40	100	30	30	60
		Тройник 7	110/110	30/30	—	40/40	100/100	30/30	30/—	60/40
PRPVM to PRPVM с PRPVM PRPVM		Прямое 6	75	25	—	40	70	25	—	45
		Тройник 7	110/100	30/30	—	40/40	100/100	30/30	30/—	60/40
PRPVM PRPVM с PRPVM to PRPVM		Прямое 6	120	50	30	40	110	80	60	30
		Тройник 7	120/80	50/50	30/30	40/30	110/80	80/50	60/30	30/30
5 PRPVM с PRPVM PRPPM с PRPPM PRPVM с PRPVM		8. Отвод	90	10	—	30	80	20	—	30
			А	В	С	Д	а	б	с	д
PTVZh to ПТВЖ с ПТВЖ PTVZh		Прямое 6	110	30	—	40	100	30	30	60
		Тройник 7	110/110	30/30	—	40/40	100/100	30/30	30/—	60/40
PTRZh to ПТРЖ с ПТРЖ PTRZh		Прямое 6	75	25	—	40	70	25	—	45
		Тройник 7	110/100	30/30	—	40/40	100/100	30/30	30/—	60/40

Footnote: For three way connections, the dimensions of the line cable are indicated in the numerator, and indicated in the denominator are the dimensions for the branch cable.

Key: 1. Type of cable; 2. Type of connection; 3. Dimensions, mm;  
4. PRPPM to PRPPM, PRPPM to PRPVM; 5. PRPVM to PRPVM, PRPPM to PRPPM, PRPVM to PRPVM; 6. Direct; 7. Three way; 8. Branch-off.

in a permanent shop, the cores are soldered with an electric soldering iron, or a soldering iron heated with a soldering torch. Aluminum cores are welded

in the flame of a soldering torch. Under field conditions, it is convenient to solder copper cores using a cup type soldering iron, the design of which is shown in Figure 3.15. The soldering iron is heated with a thermite muffle cartridge (for welding 5 mm steel wires). Aluminum cores are welded with the same cartridge, which is inserted in a special holder. The core twists are bent down against the cable after soldering or welding. The sequence for making the connection of current carrying cores of single pair cables is shown in Figure 3.16. The configurations for replacing the insulation covers of single pair cables are shown in Table 3.60. The dimensions of the polyvinylchloride and polyethylene tapes used in the installation are given in Table 3.61.

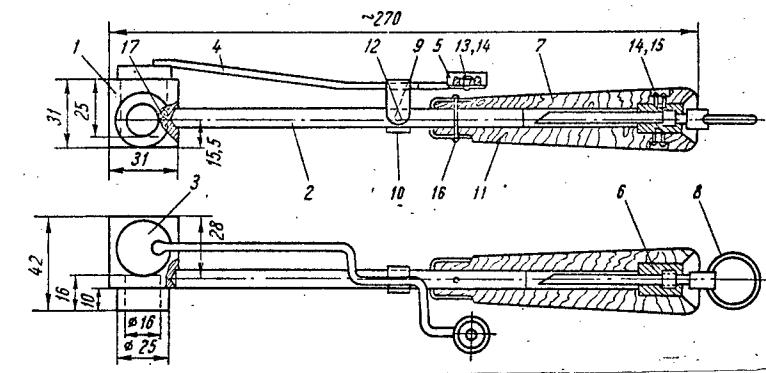

Figure 3.15. Cup type soldering iron

Key: 1. Collar ring; 2. Rod; 3. Cover cap; 4. Bar; 5. Knob; 6. Bushing; 7. Blade; 8. Ring; 9. Spring; 10. Insert piece; 11. Handle; 12. Hinge; 13. Rivet; 14. Disc; 15. Screw; 16. Pin; 17. Thermite muffle cartridge.

TABLE 3.59. The Connection of Current Carrying Cable Cores

Core Material	Method of Connection	Solder	Flux
Copper	Soldering	POS-40	Rosin
Steel	Soldering	POS-40	A solution of zinc chloride ([or] o hydrochloric acid, zinc etched)
Aluminum	Welding	-	Flux compositions: Potassium chloride - 43% Sodium chloride - 22% Barium chloride - 20% Sodium chloride - 15% [sic] or Sodium chloride - 25% Potassium chloride - 58% Sodium chloride - 17% [sic].

TABLE 3.59. [Continued] The Connection of Current Carrying Cable Cores

<u>Core Material</u>	<u>Method of Connection</u>	<u>Solder</u>	<u>Flux</u>
Aluminum	Soldering	Solder of the following composition: Cadmium - 20% Tin - 72% Zinc - 8%	Flux F-59-A, consisting of: Trichloramine - 82% Cadmium fluoroborate - 10% Ammonia fluoroborate - 5% Zinc fluoroborate - 3% (the soldering location is covered with PVKh-26 [PVC] moisture repellent varnish).



- Notes:
1. When connecting copper cores to aluminum and steel ones, the cores are tinned by the method indicated in the table, after which they are twisted and soldered with POS-40.
  2. The flux residues are cleaned off after welding.
  3. In making branching connections, the cores are soldered with a standard soldering iron.
  4. Aluminum cores are soldered with cadmium solder using F-59-A flux and a cup type soldering iron.

To restore polyvinylchloride insulation and jacketing, a mixture of plasticizers or perchlorovinyl glue is used as the adhesive compound. To restore polyethylene coatings, a polyisobutylene mass is employed. The use of a mixture of plasticizers requires heating the junctions in a saturated solution of table salt (450 g per 1 ltr of water). Perchlorovinyl glue does not require heating the junctions. The compositions of the adhesive compounds are given in Table 3.62. For convenience in winding the tapes, the cable with the junction is placed on a work stand. Prior to winding on the tape, the sections of insulation and jacketing adjacent to the junction are stripped off with an installer's knife. The tapes are wound with a 50% overlap, in layers. Each layer should extend over the insulation (or the jacketing) by 5 - 6 mm. In making three way connections, the tapes are wound on the cable of the line and the cable of the branch lead. The tapes are wound with moderate tension. The first five to six layers of polyethylene tapes are wound on the twist of the cores without polyisobutylene when installing PRPPM, PRPVM and PTVZh cables.

The adhesive compounds are applied to the tape with a soft brush, while the polyisobutylene is applied with a wooden spatula.

When using the plasticizer mixture, the wound on tapes are secured with cotton insulating or calico tapes. The securing tape is wound on each core of the single pair cable in one layer with a 50% overlap. The wound on tape is bound with cord. The secured junction is heated in a special tank or metal vessel. The junction is immersed in the cold solution at a temperature of no more than + 30° C. The tank is heated with a soldering torch so that the solution boils in no less than 30 minutes. The junctions of single pair cables are held in the adhesive solution for eight to ten minutes. Thereafter, they are taken out of the solution and cooled under natural conditions for three to five minutes.

TABLE 3.60. Configurations for the Restoration of the Insulation Covers of Single Pair Cables

Марка кабеля Type of Cable	Configurations for re- Схема восстановления изоляционных п/ковров storing the insulation covers	RestoratorСпособ восстановления изоляции Insulation	Method оболочка Jacket
ПРВПМ, ПТВЖ ПРВРМ, РТВЗж		1 Каждую жилу по поливинилхлоридной изоляции обматывают поливинилхлоридной лентой с клеевым составом	
ПРПВМ ПРРВМ		2 Каждую жилу по полиэтиленовой изоляции обматывают полиэтиленовой лентой с полиизообутиленовой массой	
ПРПЖ ПРРЖ			3. Каждую жилу по поливинилхлоридной оболочке обматывают поливинилхлоридной лентой с клеевым составом 4. Каждую жилу по полиэтиленовой оболочке обматывают полиэтиленовой лентой с полиизообутиленовой массой, а затем поливинилхлоридной лентой с клеевым составом

Footnote: The use of adhesive polyethylene or polyvinylchloride tape which is wound on in no less than six layers is permitted in the installation of PRPPM and PTPZh cables, in place of polyvinyl chloride tape with glue compounds. In this case, the junctions are not heated.

- Key: 1. Each polyvinylchloride insulated core is wrapped with polyvinylchloride tape with an adhesive compound;  
 2. Each polyethylene insulated core is wound with polyethylene tape with polyisobutylene;  
 3. Each core in a polyvinylchloride jacket is wound with polyvinylchloride tape with an adhesive compound;  
 4. Each core in a polyethylene jacket is wound with polyethylene tape with polyisobutylene, and then with polyvinylchloride tape with an adhesive compound.

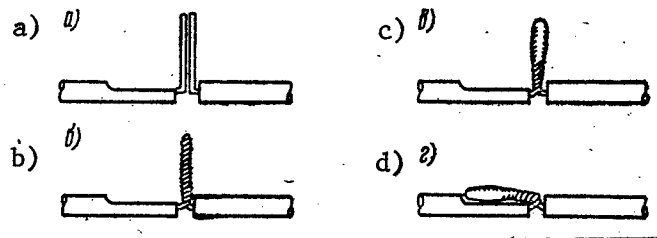

Figure 3.16. The connection sequence for the current carrying cores of single pair cables.

- a) Wire prepared for joining; b) Twisted and cut off wires;  
 c) Soldered wire twist; d) Twist bent down against the cable core.

TABLE 3.61. The Dimensions of Tapes Used in the Installation of Single Pair Cables

Type of Cable	Quantity and Dimensions of the Tapes for:			
	The Cores		The Jacketing	
	Straight Junction	Three Way	Straight Junction	Three Way
PRVPM, PTVZh	Two PVC tapes, each 1 m long, 0.15-0.25 mm thick, 15 mm wide.	Two PVC tapes, each 1 m long, 0.15-0.25 mm thick, 15 mm wide		
PRPVM	Two PE tapes, each 0.7 m long, 0.1 - 0.15 mm thick, 15 mm wide.	Two PE tapes, each 1.5 m long, 0.1-0.15 mm thick, 15 mm wide.	Two PVC tapes, each 1 m long, 0.15-0.25 mm thick, 15 mm wide.	Two PVC tapes, each 1.5 m long, 0.15-0.25 mm thick, 15 mm wide.
PRPPM, PTPZh			Two PE tapes, each 0.7 m long, 0.15-0.25 mm thick, 15 mm wide, and two PVC tapes, each 1 m long, 0.15-0.25 mm thick, 15 mm wide.	Two PE tapes, each 1.5 m long, 0.1-0.15 mm thick, 15 mm wide, and two PVC tapes, each 1.5 m long, 0.15-0.25 mm thick, 15 mm wide.

Footnote: PE = Polyethylene; PVC = Polyvinylchloride.

Following cooling, the securing cord and tape is removed from the junctions. The junctions are flushed with clean water and inspected. There should be no cracks or breaking away of the tape layers at their surface.

When making junctions using perchlorovinyl glue, the work is done wearing rubber gloves in the open air, or in a well ventilated room. After working with the glue, it is necessary to wash the hands carefully (soap and water).

TABLE 3.62. The Compositions of Adhesive Compounds

Designation	Composition	GOST or TU*	Method of Preparation
Mixture of plasticizers	Dimethylphthalate, 85%; dibutylphthalate, 15%; polyvinylchloride plastic finely cut up (2.5 g of plastic per 100 g of mixture).	GOST 8728-58 GOST 5960-51	The plasticizers are measured out, poured together and mixed. To dissolve the tape, the mixture is heated at a temperature of +70 - 80° C.
Perchloro-vinyl glue	Methylene chloride, 85%; perchlorovinyl resin, 15% (adhesive);	TU MKhP 3105-52 TU MKhP 4274-54	The methylene chloride and the resin are measured out and mixed. Methylene chloride is injurious to human health. The glue is prepared in the open or in a fume cabinet. After working with the glue, it is necessary to wash the hands carefully with soap.
Polyisobutylene	P-20 polyisobutylene, 69 g; P-85 polyisobutylene, 6 g; B-70 benzene, 25 g per 100 g of [polyisobutylene] mass.	TU MKhP 1761-54 TU MKhP 1665-54 GOST 443-56	The polyisobutylene is measured out, pulverized down to a size of 1 - 3 cm <sup>3</sup> , mixed, and the benzene is poured over it. The mass is kept in a closed container, being mixed daily. It is ready for use after five to six days.

\* GOST = State Standard; TU = Technical Specifications.

Note: The mixture of plasticizers is poured into polyethylene or glass bottles with a capacity of 0.1 - 0.25 ltrs. Polyethylene and glass containers with hermetically sealing stoppers are used for perchlorovinyl glue. Applied to them are labels with the inscription, "Caution! Perchlorovinyl glue".

The polyisobutylene mass is poured into a glass container with a capacity of 0.1 - 0.25 liters and having a wide mouth.

When installing single pair cables under fixed shop conditions, the finished cables are wound on the reel of a cable layer. However, if the mounting is performed under field conditions, then the cable reserve and the junction are layed on the bottom of the excavation and sprinkled with loose earth. After finishing each junction, electrical measurements of the insulation resistance are made. The measurements are made from the nearest end of the finished section of the line.

During the operational acceptance of newly built or major overhauled lines, consisting of single pair cables, their insulation resistance, figured per 1 Km; should be no less than 75% of the magnitude established for the insulation resistance of the cable.



The insulation resistance of single pair cable lines in operation should be no less than 3 MOhm·Km. After the electrical measurements, the positions of the junctions are noted on the line route schematic (indicating the distance from the junction to the nearest terrain orientation points) and the excavations are filled in.

The procedure for installing single pair cables is set forth in detail in the "Vremennoye rukovodstvo po prokladke i montazhu odnoparnykh kabeley s plast-massovoy izolyatsiey dlya radiofikatskii i sel'skoy telefonnoy svyazi" ["Provisional instructions for the laying and installation of single pair cables with plastic insulation for radio repeater and rural telephone communications"], Moscow, Svyaz'izdat, 1963.

#### The Installation of Single Quadded Cables

Single quadded cables with polyethylene jacketing are installed on rural telephone communications lines in the following manner:

- By restoring the polyethylene insulation using polyethylene tapes with polyisobutylene when joining the polyethylene jacket with polyethylene coupling sleeves, which are fused to the jacket under fiberglass tape with an open flame;
- By restoring the polyethylene insulation through pressure molding of the core insulation and the strip insulation of the cable using molten polyethylene and by restoring the polyethylene jacket with a polyethylene coupling sleeve, fused to the jacket with an open flame under a fiberglass tape.

Single quadded cables with polyvinylchloride jackets may be installed using the following methods:

- By restoring the polyethylene insulation using polyethylene tapes with polyisobutylene when joining the polyvinylchloride jacketing with polyvinylchloride tubes, fused to the jacket with copper bushings heated by a soldering torch;
- By restoring the polyethylene insulation using polyethylene tapes with polyisobutylene when joining a polyvinylchloride jacket using polyvinylchloride tapes with a plasticizer mixture and heating the junctions in boiling salt water;
- By restoring the polyethylene insulation through press molding of the core insulation and the strip insulation of the cable with molten polyethylene and by restoring the polyvinylchloride jacket using a polyvinylchloride tube fused to the jacket by means of a welding rod in a hot stream of air.

A listing of the tools, accessories and equipment required by one installation brigade for the installation of a single quadded cable is given in Table 3.63.

Given in Table 3.64 is a list and the amount used of the installation materials required for making 10 direct junctions of a single quadded cable.

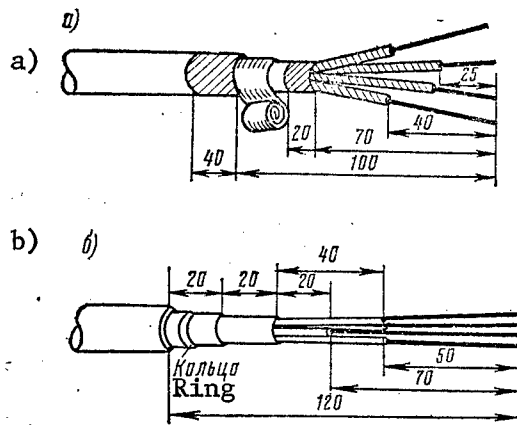

Figure 3.17. The dimensions for stripping KSPP-1x4x1.2 cable:

- a) When restoring the insulation with polyethylene tapes;
- b) When press molding the junction.

The ends of the cables to be worked are cleaned of dirt. The jacketing and insulation is removed from the end of the cable. The dimensions of the stripped sections should correspond to the quantities indicated in Figure 3.17. The dimensions of the tapes, tubing, four-way unions, and so forth, of the materials which are used in the installation of single quadded cables, are indicated in Table 3.65. The compositions of the adhesive compounds are given in Table 3.62.

Single quadded cables are stripped with an installer's knife. The cores are twisted over a length of 25 mm with a minimum pitch. The twisted cores are soldered or welded according to the data of Table 3.57. Copper cores are soldered with a soldering gun, heated by thermite muffle cartridges. The twists are bent down against the cable cores.

The cable with the junction is positioned in the installation work stand. Each core is wrapped with polyethylene tape with polyisobutylene. The tapes are wrapped with a 50% overlap. The first five to six layers are wrapped on the twisted cores without the polyisobutylene.

After restoring the core insulation, the strip insulation is restored. The restoration is accomplished using polyethylene tape with polyisobutylene. The tape which is wound on is bound with a narrow polyethylene strip to protect against its unwinding by itself. The shield wire is wound on the junction and connected with a simple twist. Aluminum shield wires are wound with a 15 - 20% overlap and joined together with a roofing seam.

The polyethylene jackets of single quadded cables are restored with polyethylene coupling sleeves. Prior to connecting the cores, the polyethylene half-sleeves are placed on both ends of the cable. After restoring the core insulation, the strip insulation and the shield, the half-sleeves are moved up over

TABLE 3.63. List of Tools, Accessories and Equipment for the Installation of Single Quadded Cables

Tools, Accessories and Equipment	PE Jacket	PVC Jacket		
	When restoring the insulation with tapes, the jacket with a PE coupling sleeve fused under fiber-glass tape	When restoring the jacket with copper inserts	When restoring the jacket with PVC tapes with a plasticizer mixture	When press molding the junction and restoring the jacket with a welding rod
Mobile electrical generator	-	-	-	1
S-511 compressor (or vacuum cleaner)	-	-	-	1
Monitor and distribution panel	-	-	-	1
Step-down transformer	-	-	-	1
Welding gun	-	-	-	1
Press former	-	-	-	1
Extruder	-	-	-	1
Installation work bench	1	1	1	1
Soldering iron	1	1	1	2
Installer's knife	2	2	2	2
Sidecutters	1	1	1	1
Pliers	1	1	1	1
Tape measure	1	1	1	1
Soft brush	-	-	1	-
Wooden spatula	1	-	1	-
Copper inserts	1	1	1	-
Soldering torch	1	1	1	-
Tank for heating the junctions	-	-	1	-
Canvas gauntlets	-	1	1	1

Note: 1. When installing single quadded cables with aluminum cores, a holder for thermite muffle cartridges, with which the cores are welded under flux, is used instead of a soldering iron.  
 2. Here and in the following, PE = Polyethylene; PVC = Polyvinylchloride.

TABLE 3.64. Listing and Consumption of Installation Materials  
(Figured for 10 Straight Junctions for a Single Quadded Cable)

Material	Unit of Measurement	PE Jacket	PVC Jacket	Jacket	
		When restoring the insulation with PE tapes, and the jacketing with PE coupling sleeves fused under fiberglass tape	When restoring the jacket with copper inserts	When restoring the jacket with PVC tapes with a mixture of plasticizers	When press molding the junction and restoring the jacket with a welding rod.
POS-40 solder	g	10	10	10	10
Rosin	g	4	4	4	4
Polyethylene tape	g	350	75	75	-
Polyvinylchloride tape	g	-	-	380	250
Mixture of plasticizers	g	-	-	30	-
Polyisobutylene	g	120	120	120	-
Insulating cotton tape	g	-	-	10	-
Cording	g	-	-	5	-
Table salt	Kg	-	-	1	-
Water	ltr	-	-	2.5	-
Gasoline	ltr	1.5	1.0	2.0	1.25
Rags	g	50	50	50	50
Thermite muffle cartridges	No.	11	11	11	11
Thermite starter matches	No.	12	12	12	12
Polyethylene coupling sleeves	No.	10	-	-	-
PVC tubing (coupling sleeve)	No.	-	10	-	10
PVC rod stock	g	-	-	-	200
Polyethylene four-way union	g	-	-	-	20
Granular polyethylene	g	-	-	-	400
Slotted steel coupling sleeve with two rings (for restoring the shield)	No.	-	-	-	10
Rubberized tape	No.	-	1	-	-
Fiberglass tape	g	200	-	-	-
Household soap	g	50	50	50	50

TABLE 3.65. The Sizes of Installation Materials for Single Quadded Cables

Material	Q U A N T I T Y		
	PE Jacket	PVC Jacket	Jacket
	When restoring insulation with PE tapes and the jacketing using a PE coupling sleeve with fusion.	When restoring the jacket with copper inserts	When restoring the jacket with PVC tapes and the plasticizer mixture.
Polyethylene tape for restoration	4 PE tapes, 0.7 m long, 10 mm wide, 0.1-0.15 mm thick	4 PE tapes, each 0.7 m long, 10 mm wide, 0.1-0.15 mm thick	4 PE tapes, each 0.7 m long, 10 mm wide, 0.1-0.15 mm thick
Polyethylene tape for restoration	1 PE tape, 2 m long, 10-15 mm wide, 0.1-0.15 mm thick	1 PE tape, 2 m long, 10-15 mm wide, 0.1-0.15 mm thick	1 PE tape, 2 m long, 10-15 mm wide, 0.1-0.15 mm thick
Polyethylene tape for restoration	3 tapes, each 1.5 m long, 20 mm wide, 0.1-0.2 mm thick	-	-
Fiberglass tape	3 tapes, each 0.5 m long, 20 mm wide, 0.2-0.4 mm thick	-	-
Polyvinylchloride tape for restoration	-	PVC tape, 6 m long, 20 mm wide, 0.15-0.20 mm thick	PVC tape, 0.5 m long, 20-25 mm wide, 0.8-1.0 mm thick.
Polyvinylchloride tubing	-	1 PVC tube, 260 mm long, with an inside diameter of 20-22 mm, and wall thickness no less than 1.5 mm	1 PVC tube, 260 mm long with an inside diameter of 20-22 mm, having a wall thickness of no less than 1.5 mm
Polyvinylchloride rod	-	-	2 sections, 0.45 m long, d = 3.5-4 mm.
Polyethylene four-way junction	-	[For last column] →	1 PE four-way union, 75 mm long, with a rib thickness of 2 mm, rib height of 4-5 mm.

the junction and coupled together. The coupling sleeves are fused to both jackets using an open flame underneath fiberglass tape. Polyethylene tapes are wrapped on the junction of the half-coupling sleeves, on the cable jacket and on the cones of the coupling sleeves so that the thickness of the wrapped on layer matches the thickness of the jacket. Then the polyethylene tapes are wrapped on with two layers of fiberglass tapes. The ends of the tapes are secured with soft wire. The fiberglass tape is heated uniformly with the flame of a soldering torch.

After cooling the melted joint down to 50° C, the fiberglass tape is removed. If defects are detected when inspecting the point of the weld (incomplete fusions, holes, bubbles), then polyethylene tape and fiberglass tape are wrapped on again, and an additional fusing is carried out.

When restoring a polyvinylchloride jacket by means of fusion with copper inserts, prior to connecting the cores, a polyvinylchloride tube is placed on one end of the cable. After the shield is restored, the tube is moved up over the junction and positioned so that it covers the contiguous parts of the jacket over the same length. Two copper inserts are inserted under the tube from one end of the junction. The end of the tube with the inserts is wrapped with rubber tape 10 to 15 mm wide. The tail portions of the inserts are heated in turns with a soldering torch. After heating the sections of the inserts introduced into the coupling sleeve up to a temperature of + 180 - 200° C, they squeeze out spontaneously by themselves and fall out. The coupling sleeve is cooled for two to three minutes, being held stationary, after which the rubber tape is unwound and removed. The point of the weld is inspected. There should be no deep creases, incomplete fusions or burns in it. The polyvinylchloride residues are removed from the cooled inserts. The other end of the coupling sleeve is fused to the jacket in a similar fashion.

When restoring the polyvinylchloride jacket of single quadded cables using polyvinylchloride tapes with a mixture of plasticizers, they are wrapped on the junction after the shield is restored (as indicated for single pair cables). The polyvinylchloride tape which is wrapped on is secured by rubber impregnated cotton insulating or calico tape and is bound with cord. The secured junction is immersed in a bath with cold salt water. The bath is heated to boiling for 30-35 minutes. The junctions of single quadded cables are kept in the boiling solution for 10 - 12 minutes. Then the junctions are removed from the solution and cooled off. The cording and the securing tape is removed from them. The junctions are flushed with water and inspected. There should be no cracks or emissions of the polyisobutylene in them.

When installing single quadded cables using the press forming method, the current carrying cores are soldered in the usual fashion, after which a polyethylene four-way crosspiece is inserted between them. The junction is placed in the press former, which is fastened to the installation work stand. After heating the press former and the injection molder with the polyethylene, they are joined together. The molten polyethylene is injected into the press former. The shield is restored at the press molded junction with two steel fishplates, after which polyvinylchloride tape is wrapped on it. Then, a

polyvinylchloride tube is slipped over it, which was placed on one of the cable ends beforehand. The tubing is fused to the jacket with the inserts or by means of a welding rod heated by a jet of hot air obtained from a welding gun.

Cable jackets of different materials (polyvinylchloride and polyethylene) are joined together by means of special transition sleeves.

The quality of the junctions is checked by electrical measurements which are conducted from the near end of the finished section of the line. The junctions are considered to be of good quality if the resistance of the insulation of the line section figured for each 1 Km is no less than the values indicated in section 3.2. At the points where the junctions of single quadded cables are located, gauging posts are set up.

The positions of the junctions of single pair cables are marked on the schematic of the line route.

The procedure for the installation of single quadded cables is set forth in detail in "Vremennaya instruktsiya po prokladke i montazhu odnochetverochnykh kabeley tipa KSPP" ["Provisional Instructions for the Laying and Installation of Single Quadded Type KSPP Cables"], Moscow, Svyaz' Publishers, 1970.

#### The Installation of Multipair Cables with Plastic Insulation and Jacketing

Cables with polyethylene insulation of the TPP and TPPB types find application on rural telephone network lines. On suspension lines, and when the lines are run through the walls of buildings and inside rooms, cables with polyvinylchloride jacketing having a capacity of up to 100 pairs of the TPV type can be used.

The cable cores having the same diameter are connected together with a simple twist. In this case, to speed the process of connecting the cores of the cables, the use of a paired method of joining them together is recommended. The core twists are insulated with polyethylene liners. Insulating two core twists with one common liner is permitted.

The position of the finished cores in pairs or quads is established by grouping rings or lacing with gray twine.

The installation of the polyethylene jackets of multipair cables is accomplished by:

- Fusing the polyethylene coupling sleeves to the cable jackets and the parts of the coupling sleeve to each other with polyethylene tapes, which are heated under a fiberglass tape with the open flame of a soldering torch or gas burner;
- Fusing the polyethylene coupling sleeves to the cable jackets and the parts of the coupling sleeves to each other with copper inserts, which are heated by a soldering torch or a gas burner (for a cables with a capacity of more than 100 pairs);

- Fusing the polyethylene coupling sleeves to the cable jackets and the parts of the coupling sleeves to each other by electrically heating them;
- Fusing the polyethylene coupling sleeves to the cable jackets, and the parts of the coupling sleeves to each other with a polyethylene rod, heated by a flow of hot nitrogen.

Inside dry buildings the installation of distribution cables with a capacity of up to 100 pairs is permitted using polyethylene coupling sleeves and adhesive polyethylene tapes, and for those with a capacity of up to 20 pairs, using only one adhesive polyethylene tape.

The installation of the polyvinylchloride jackets of multipair cables is accomplished by:

- Fusing the polyvinylchloride coupling sleeves to the jackets of the cables and the parts of the coupling sleeves to each other by means of copper inserts;
- Fusing the polyvinylchloride coupling sleeves to the cable jackets and the parts of the coupling sleeves to each other using a polyvinylchloride rod, heated with hot air.

In dry rooms, the installation of distribution cables with a capacity of up to 100 pairs inclusive is permitted using polyvinylchloride coupling sleeves, which are connected to each other and to the cable using polyvinylchloride adhesive tape. For cables with a capacity of up to 20 pairs, the wrapping of the junction with six to eight layers of polyvinylchloride adhesive tape is permitted, without the use of coupling sleeves.

Armored cables of the TPPB and TPPBP types are installed using plastic and cast iron couplings. Cast iron coupling sleeves are filled with MKB cable compound, heated up to a temperature of no more than +95° C.

TABLE 3.66. Transition Sleeves and Coupling Sleeves

Type of Cables Being Installed	Type of Transition Sleeve	Coupling Sleeve to be Used
TPP and TG	MPK-PS	A lead or polyethylene coupling sleeve
TPV and TG	MPK-VS	A lead or polyethylene coupling sleeve
TPP and TPV	MPK-PV	A polyethylene or polyvinylchloride coupling sleeve.

The installation of multipair cables having different jacket materials is accomplished by means of transition sleeves. The type of transition sleeves and the material of the coupling sleeves are shown in Table 3.66.

The installation of cables having different jackets with a capacity of up to 30 pairs may be carried out using only transition sleeves (without the use of coupling sleeves).



The procedure for installing multipair cables is set forth in detail in "Vremenn a instruktsiya po prokladke i montazhu kabeley GTS s plastmassovoy izol'yatsiyey i obolochkoy" ["Provisional Instructions for the Laying and Installation of City Telephone Exchange Cables with Plastic Insulation and Jacketing"], Moscow, Svyaz' Publishers, 1972.

The quality of the installation work on the line sections after installing three to five coupling sleeves, and then over the entire line, is determined by checking:

- The continuity of the cores;
- Shield continuity;
- The absence of shorts between the cores;
- The absence of open pairs;
- The hermetic seal of the jacket (on cables with a capacity greater than 100 x 2).

The electrical measurements enumerated in Table 3.67 are performed on the installed and checked line.

TABLE 3.67. List of Electrical Measurements to be Performed on Multipair Cable Lines

M E A S U R E M E N T S	
Using Direct Current	Using Alternating Current
Loop resistance of the working pair cores	Crosstalk attenuation
Ohmic resistance balance in the working pairs	Working attenuation
Insulation resistance between each pair and all the remaining ones, connected to the shield and ground	
Working capacitance	

On subscriber lines using multipair cables of the TPP and TPV types, the insulation resistance should be 5,000 MOhms per Km for lines without terminals and 1,000 MOhms per Km for lines with terminal devices.

The subscriber line should have an insulation resistance of no less than 100 MOhms over the entire length.

The difference in the resistances (ohmic imbalance) of the cores over the entire length of the line should be no greater than 1% of the loop resistance.

### 3.4. ELECTRICAL MEASUREMENTS OF OPEN WIRE AND CABLE COMMUNICATIONS LINES

#### The Purpose of the Electrical Measurements

Electrical measurements of open wire and cable communications lines are conducted for the purpose of determining:

- Whether the electrical characteristics of the installations being placed in service meet the set norms;
- Whether the existing lines, grounds and protective devices meet the norms for warning of and preventing damage;
- The nature and location of damage;
- The quality of the materials and spare parts supplied by industry, as well as of a repair which has been made.

Errors in the electrical measurements are permitted which do not exceed the magnitudes given in Table 3.68.

TABLE 3.68. Permissible Measurement Errors

Type of Measurements	Unit of Measurement	Permissible Measurement Error, %
Insulation resistance:		
Up to 1,000	MOhms	±5
Greater than 1,000	MOhms	±10
Circuit resistance	Ohms	±0.5
Difference in the resistances of the conductors (cores)	Ohms	±0.3
Working capacitance of the circuit:		
From 0.005 to 0.4	μfd	±3
From 0.4 to 5	μfd	±2
Absolute value of the characteristic or input impedance of the circuit	Ohms	±0.5
Line interference (noise) of the circuit	dB (Nep)	±0.9 (0.1)
Inherent or working attenuation of the circuit	dB (Nep)	±0.43 (0.05)
Crosstalk attenuation and isolation between the circuits, and the attenuation imbalance over the length of the circuit	dB (Nep)	±0.9 (0.1)
Resistance of line grounds	Ohms	±3.0
Firing voltage of the dischargers	V	±10

TABLE 3.69. Electrical Measurements on the Lines, Grounds and Protective Devices of Rural Telephone Networks

Измеряемая характеристика	Plan. Главные измерения Measurements						A. Контр-не уплотненных и удаленных абонентов
	1	2	3	4	5	6	
Direct Постоянный ток Current Сопротивление изоляции каждой жилы (провода) цепи по отношению к другим жилам (проводам), соединенным с землей (экраном)	1	2	3	4	5	6	До и после ремонта 100% 16.
10.	То же The same	Один раз в квартал и по мере необходимости 100% 14.	Один раз в квартал и по мере необходимости 100% 14.	Один раз в квартал и по мере необходимости 100% 14.	Один раз в год и по мере необходимости 100% 15.	То же The same	16.
11.	То же The same	То же The same	То же The same	То же The same	То же The same	То же The same	То же The same
12.	Рабочая емкость кабельной цепи	"	"	"	"	"	"
13.	Сопротивление цепи Circuit Resistance Разность сопротивлений жил (проводов) цепи	"	"	"	"	"	"

Key: [Columns] 1. Characteristic being measured; 2. Nonmultiplexed and remote subscribers; 3. Multiplexed; 4. With terminal amplifiers; 5. Local subscribers; 6. Non-multiplexed and remote subscribers;  
 A. Check measurements;  
 [Column 1] 10. The insulation resistance of each circuit core (wire) with respect to other cores (wires), connected to ground (to the shield); 11. The insulation resistance of the shield of the cable line with respect to ground; 12. The working capacitance of the cable circuit; 13. The difference in the resistances of the circuit cores (wires);  
 [Across] 14. Once quarterly, and as required, 100%. 15. Once annually, and as required, 100%; 16. Before and after repair, 100%.

TABLE 3.69 [Continued] Electrical Measurements on the Lines, Grounds and Protective Devices of Rural Telephone Networks

охлаждающие измерения		Приемо-сдаточные измерения				
А.		В.				
уплотненных	с оконечными усилителями	местных абонентов	неуплотненных и удаленных абонентов	уплотненных	с оконечными усилителями	местных абонентов
7	8	9	10	11	12	13
До и после ремонта 100% С.	До и после ремонта 100% С.	До и после ремонта 100% С.	100%	100%	100%	25-50%
То же	То же	То же	*	*	*	*
The same	The same	The same				
*	*	*	*	*	*	*
*	*	*	*	*	*	*
*	*	*	*	*	*	*

Key: A. Check measurements; B. Acceptance measurements; C. Before and after repair, 100%; [Columns]: 7. Multiplexed; 8. With terminal amplifiers; 9. Local subscribers; 10. Non-multiplexed and remote subscribers; 11. Multiplexed; 12. With terminal amplifiers; 13. Local subscribers.

TABLE 3.69 [Continued] Electrical Measurements on the Lines, Grounds and Protective Devices of Rural Telephone Networks

Characteristic Being Measured	Planned Measurements for:					Check Measurements for: Nonmultiplexed and Remote Subscribers
	Nonmultiplexed and Remote Subscribers	Multiplexed With Terminal Amplifiers	Local Subscribers	Local Subscribers	Local Subscribers	
1	2	3	4	5	6	
The electrical strength of the insulation between all cores, interconnected and grounded to the shield, as well as between the cores of the cable line circuit.	Once annually and as required, 100%	Once annually and as required, 100%	Once annually and as required, 100%	Once annually and as required, 100%	Once annually and as required, 100%	Before and after repair, 100%
Alternating Current						
Absolute value of the characteristic or input impedance	As required, at $f = 0.8$ KHz	As required, in a frequency range of 0.8-120 KHz.	As required, at $f = 0.8$ KHz	As required, at $f = 0.8$ KHz	As required, at $f = 0.8$ KHz	As required, at $f = 0.8$ KHz
Working or inherent attenuation of a physical circuit	Once annually, and as required in a frequency range of 0.3-3.4 KHz, 100%.	Once annually, and as required in a frequency range of 0.8-120 KHz, 100%	Once annually, As required in a frequency range of 0.3-3.4 KHz, 100%	The same	As required, in a frequency range of 0.3-3.4 KHz.	As required, in a frequency range of 0.3-3.4 KHz.
Working or inherent attenuation of a phantom circuit when organizing a hard wire broadcast channel	-	Once annually and as required in a frequency range of 0.1-6.0 KHz, 100%.	-	-	-	-

TABLE 3.69. [Continued from Page 136]

основные измерения		Check Measurements			Acceptance			Measurement		
уплотненных	с оконечными усилителями	местных абонентов	неуплотненных и удаленных абонентов	уплотненных	с оконечными усилителями	местных абонентов	уплотненных	с оконечными усилителями	местных абонентов	
7	8	9	10	11	12	13	14	15	16	
	*	*	*	*	*	*				
14. По мере необходимости в спектре частот 0,3-120 кГц	15. По мере необходимости на частоте $f = 0,8$ кГц	—	15. По мере необходимости на частоте $f = 0,8$ кГц	14. По мере необходимости в спектре частот 0,8-120 кГц	15. По мере необходимости на частоте $f = 0,8$ кГц	—	14. По мере необходимости в спектре частот 0,8-120 кГц	15. По мере необходимости на частоте $f = 0,8$ кГц	—	
16. На частоте 120 кГц 100%	17. По мере необходимости в спектре частот 0,3-3,4 кГц 100%	15. По мере необходимости на частоте $f = 0,8$ кГц	18. В спектре частот 0,3-3,4 кГц 100%	19. В спектре частот 0,8-120 кГц 100%	18. В спектре частот 0,3-3,4 кГц 100%	15. По мере необходимости на частоте $f = 0,8$ кГц	19. В спектре частот 0,8-120 кГц 100%	18. В спектре частот 0,3-3,4 кГц 100%	15. По мере необходимости на частоте $f = 0,8$ кГц	
20. В спектре частот 0,1-6,0 кГц 100%	—	—	—	20. В спектре частот 0,1-6,0 кГц 100%	—	—	20. В спектре частот 0,1-6,0 кГц 100%	—	—	

Key: [Columns] 7. Multiplexed; 8. With terminal amplifiers; 9. Local subscribers; 10. Non-multiplexed and remote subscribers; 11. Multiplexed; 12. With terminal amplifiers; 13. Local subscribers.

[Entries] 14. As required in a frequency range of 0.8-120 KHz; 15. As required at  $f = 0.8$  KHz; 16. At a frequency of 120 KHz, 100%; 17. As required in a frequency range of 0.3-3.4 KHz, 100%. 18. In a frequency range of 0.3-3.4 KHz, 100%; 19. In a frequency range of 0.8-120 KHz, 100%; 20. In a frequency range of 0.1-6.0 KHz, 100%.

TABLE 3.69. [Continued] Electrical Measurements on the Lines, Grounds and Protective Devices of Rural Telephone Networks

Characteristic Being Measured	Planned Measurements				14. Контр-не уплотненных и удаленных абонентов
	2. неуплотненных и удаленных абонентов	3. уплотненных	4. с оконечными устройствами	5. местных абонентов	
15. Переходное затухание между основными цепями на ближнем конце линии	1 раз в год и по мере необходимости на $f=0,8$ кГц 100% 16.	1 раз в год и по мере необходимости в спектре частот 0,8-120 кГц 100% 17.	1 раз в год и по мере необходимости на $f=0,8$ кГц 100% 16.	По мере необходимости на $f=0,8$ кГц 100% 18.	на $f=0,8$ кГц 100% 19.
20. Переходное затухание между искусственной и основными цепями на ближнем конце линии при организации канала проводного вещания	—	1 раз в год и по мере необходимости 0,8 и 0,6 кГц 100% 21.	—	—	—
22. Защищенность между основными цепями на дальнем конце линии	1 раз в год и по мере необходимости на $f=0,8$ кГц 100% 16.	1 раз в год и по мере необходимости в спектре частот 0,8-120 кГц 100% 17.	1 раз в год и по мере необходимости на $f=0,8$ кГц 100% 16.	—	на $f=0,8$ кГц 100% 19.
23. Защищенность между искусственной и основными цепями на дальнем конце линии при организации канала проводного вещания	—	1 раз в год и по мере необходимости на $f=0,8$ и 6,0 кГц 100% 24.	—	—	—

Key: [Columns] 2. Nonmultiplexed and remote subscribers; 3. Multiplexed; 4. With terminal amplifiers; 5. Local Subscribers; 6. Nonmultiplexed and remote subscribers; 14. Check measurements [Entries] 15. Crosstalk attenuation between physical circuits at the near end of a line; 16. Once annually and as required at  $f = 0.8$  KHz, 100%; 17. Once annually and as required in a frequency range of 0.8-120 KHz, 100%; 18. As required at  $f = 0.8$  KHz, 100%; 19. At  $f = 0.8$  KHz; 20. Crosstalk attenuation between physical and phantom circuits and the near end of a line when organizing a hard wire broadcast channel; 21. Once annually and as required at 0.8 and 0.6 [sic] KHz, 100%; 22. Isolation between physical circuits at the far end of a line; 23. Isolation between phantom and physical circuits at the far end of a line when organizing a hard wire broadcast channel; 24. Once annually and as required at  $f = 0.8$  and 6.0 KHz, 100%.

TABLE 3.69 [Continued from page 138] Electrical Measurements on the Lines, Grounds and Protective Devices of Rural Telephone Networks

Основные измерения		Check Measurements		Acceptance		Приемо-сдаточные измерения		Measurements	
Уплотненных	Уплотненных	с оконечными усилителями	местных абонентов	неуплотненных и удаленных абонентов	Уплотненных	с оконечными усилителями	местных абонентов	Уплотненных	с оконечными усилителями
7	8	9	10	11	12	13	14	15	16
В спектре частот 0,8-120 кГц 100%	на $f=0,8$ кГц 100%	По мере необходимости на $f=0,8$ кГц 16.	на $f=0,8$ кГц 100%	В спектре частот 0,8-120 кГц 100%	на $f=0,8$ кГц 100%	По мере необходимости на $f=0,8$ кГц, 16.	14.	15.	15.
На $f=0,8$ и 6,0 кГц 100%	-	-	-	На $f=0,8$ и 6,0 кГц 100%	-	-	18.	18.	-
В спектре частот 0,8-120 кГц 100%	-	-	На $f=0,8$ кГц 100%	В спектре частот 0,8-120 кГц 100%	На $f=0,8$ кГц 100%	-	17.	17.	15.
На $f=0,8$ и 6,0 кГц 100%	-	-	-	На $f=0,8$ и 6,0 кГц 100%	-	-	18.	18.	-

Key: [Columns] 7. Multiplexed; 8. With terminal amplifiers; 9. Local Subscribers; 10. Nonmultiplexed and remote subscribers; 11. Multiplexed; 12. With terminal amplifiers; 13. Local subscribers;

14. In a frequency range of 0.8-120 KHz, 100%; 15. At  $f = 0.8$  KHz, 100%; 16. As required at  $f = 0.8$  KHz; 17. In a frequency range of 0.8-120 KHz, 100%; 18. At  $f = 0.8$  and 6.0 KHz, 100%.



TABLE 3.69. [Continued] Electrical Measurements on the Lines, Grounds and Protective Devices of Rural Telephone Networks

Characteristic Being Measured	Planned Measurements				14. Контр-не уплотненных и удаленных абонентов
	1. Измеряемая характеристика	2. неуплотненных и удаленных абонентов	3. Уплотненных	4. с оконечными усилителями	
15. Уровень линейных помех (шумов) на основных цепях	1 раз в год и по мере необходимости в спектре частот 0,3-3,4 кГц 16. 100%	1 раз в год и по мере необходимости в спектре частот 0,3-3,4 кГц 16. 100%	1 раз в год и по мере необходимости в спектре частот 0,3-3,4 кГц 16. 100%	По мере необходимости в спектре частот 0,3-3,4 кГц 17.	В спектре частот 0,3-3,4 кГц 18. 100%
19. Уровень линейных помех (шумов) на искусственных цепях при организации канала проводного вещания	—	1 раз в год и по мере необходимости в спектре частот 0,1-6,0 кГц 20. 100%	—	—	—
21. Затухание продольной асимметрии основных цепей на ближнем конце линии	1 раз в год и по мере необходимости в спектре частот 0,8-3,4 кГц 16. 100%	1 раз в год и по мере необходимости в спектре частот 0,8-3,4 кГц 16. 100%	1 раз в год и по мере необходимости в спектре частот 0,8-3,4 кГц 16. 100%	По мере необходимости в спектре частот 0,8-3,4 кГц 22.	В спектре частот 0,8-3,4 кГц 23. 100%
24. Сопротивление заземлений на вводно-коммуникационных устройствах, кабельных ящиках, необслуживаемых усилительных пунктах аппаратуры уплотнения, тросов подвесных кабелей, молниестроительных и т. п.	Twice annually (summer and winter) and as [required, Два раза в год (летом и зимой) и по мере 100%]				
25. Напряжение зажигания разрядников на вводно-коммуникационных устройствах, кабельных ящиках и кабельных коробках НУПов аппаратуры уплотнения и т. п.	Annually before each thunderstorm season Ежегодно перед каждым грозовым периодом				

Key: [See page 142]

TABLE 3.69. [Continued from page 140] Electrical Measurements on the Lines, Grounds and Protective Devices of Rural Telephone Networks

ольные измерения		Check Measurements			Acceptance			Measurements		
		с оконечными усилителями	местных абонентов	неуплотненных и удаленных абонентов	уплотненных	с оконечными усилителями	местных абонентов			
7	8	9	10	11	12	13				
В спектре частот 0,3-3,4 кГц 100% 26.	В спектре частот 0,3-3,4 кГц 100% 18.	По мере необходимости в спектре частот 0,3-3,4 кГц 17.	В спектре частот 0,3-3,4 кГц 100% 18.	В спектре частот 0,3-120 кГц 100% 26.	В спектре частот 0,3-3,4 кГц 100% 18.	По мере необходимости в спектре частот 0,3-3,4 кГц 100% 27.				
В спектре частот 0,1-6,0 кГц 100% 28.	—	—	—	В спектре частот 0,1-6,0 кГц 100% 28.	—	—				
В спектре частот 0,8-120 кГц 100% 23.	В спектре частот 0,8-120 кГц 100% 23.	По мере необходимости в спектре частот 0,8-3,4 кГц 22.	В спектре частот 0,8-3,4 кГц 100% 23.	В спектре частот 0,8-120 кГц 100% 23.	В спектре частот 0,8-3,4 кГц 100% 23.	По мере необходимости в спектре частот 0,8-3,4 кГц 22.				
[Twice annually (summer and winter) and as required, 100%		100%	100%	100%	100%	100%				
after each severe thunderstorm and during после каждой сильной грозы и при каждом посещении объекта, 100%										
each visit to the facility, 100%										

Key: [See page 142]

[Key to Table 3.69 Continued on pages 140 and 141]:

[Columns] 1. Characteristic being measured; 2. Nonmultiplexed and remote subscribers; 3. Multiplexed; 4. With terminal amplifiers; 5. Local subscribers; 6. Nonmultiplexed and remote subscribers; 7. Multiplexed; 8. Local subscribers; 10. Nonmultiplexed and remote subscribers; 11. Multiplexed; 12. With terminal amplifiers; 13. Local subscribers; 14. Check measurements.

[Entries]:

15. Level of line interference (noise) on physical circuits; 16. Once annually and as required in a frequency range of 0.3-0.4 KHz, 100%; 17. As required in a frequency range of 0.3-3.4 KHz; 18. In a frequency range of 0.3-3.4 KHz, 100%; 19. Level of line interference (noise) on phantom circuits when organizing a hard wire broadcast channel; 20. Once annually and as required in a frequency range of 0.1-6.0 KHz, 100%; 21. Imbalance attenuation over the length of physical circuits at the near end of a line; 22. As required in a frequency of 0.8-3.4 KHz; 23. In a frequency range of 0.8-120 KHz, 100%; 24. The resistance of grounds at input-switching units, cable boxes, unmanned amplifier stations of multiplex equipment, suspension strands for suspension cables, lightning arresters, etc.; 25. Firing voltage of dischargers at input-switching units, cable boxes and cable blocks of multiplex equipment NUP's [unattended amplifier stations], etc.; 26. In a frequency range of 0.3-120 KHz, 100%; 27. As required in a frequency range of 0.3-3.4 KHz, 100%; 28. In a frequency range of 0.8-120 KHz, 100%.

The scope and frequency of the electrical measurements are indicated in Table 3.69.

All of the work related to the performance of electrical measurements on line and cable installations should be carried out with the obligatory observance and implementation of engineering safety regulations.

#### The Classification of Measurements

The electrical measurements of communications lines, grounds and protective devices are subdivided into:

- Scheduled ones, performed periodically during operation;
- Unscheduled ones, performed to determine the location of a fault point (or section);
- Inspection ones, performed on the line after completing any installation or construction work, including work related to opening up a cable during routine repairs;
- Acceptance ones, performed for the operational acceptance testing of newly built, retrofitted or overhauled lines and grounding devices.

The results of planned and check measurements serve as the initial data for the determination of the condition of the lines, grounds and protective

devices, and as a basis for working out plans for routine and major repairs or the project planning for rebuilding communications facilities.

### Direct Current Electrical Measurement Methods for Communications Lines

The insulation resistance between the conductors (cores) of a circuit, of each conductor with respect to ground (the shield), as well as for the shield of the cable with respect to ground, is measured using a voltmeter-milliammeter or a bridge. Insulation resistances up to 1,000 MOhms are measured by the

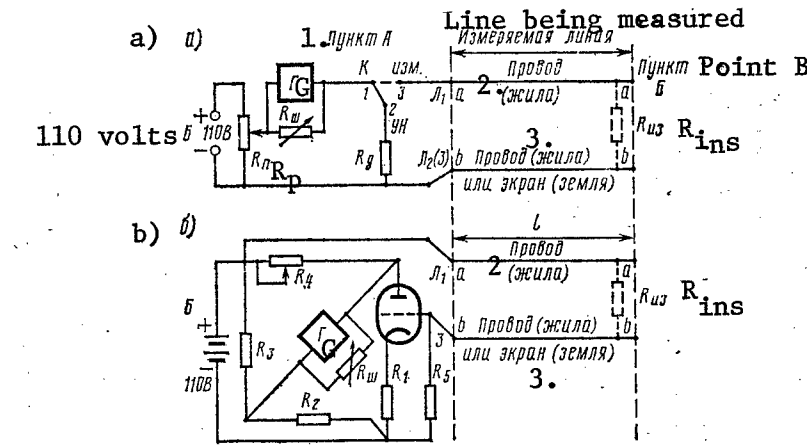

Figure 3.18. Measuring the insulation resistance between the conductors (cores) and between the conductor (core) of a circuit and the cable shield (ground).

Key: 1. Point A; 2. Conductor (core); 3. Conductor (core) or shield (ground).

voltmeter-milliammeter method (Figure 3.18a) using type PKP-2M (PKP-50), KM-61S, or PKP-3 instruments, the scales of which are graduated in Ohms (MOhms). In measuring an insulation resistance greater than 1,000 MOhms, PKP-2M, MEG-9 (MEG-8), or MOM-4 (MOM-3) instruments, where they are connected in a bridge circuit with vacuum tubes, are employed.

In measuring  $R_{ins}$ , the conductors at point B are isolated. The requisite measurement circuits for  $R_{ins} < 1,000$  MOhms are created by means of the switches on the switch panel of the measurement instrument. If  $R_{ins} > 1,000$  MOhms (for example, the insulation resistance of cable cores), the cores are connected to the other terminals of a PKP-2M instrument or a MOM-4 (MOM-3), or a MEG-9 (MEG-8) instrument. After voltage has been applied to the conductor for 1 minute, the magnitude of the insulation resistance is read from the galvanometer scale. However, the actual magnitude of the insulation resistance over the length of the line will be equal to the instrument reading multiplied by the galvanometer scale factor.

The working capacitance of a circuit or the electrical capacitance of a core with respect to the shield is measured using type PKP-2M (PKP-50), KM-61S or PKP-3 instruments (Figure 3.19).

Prior to making measurements at the opposite end of the section being measured (point B), the cores are isolated. The requisite measurement circuits are created by using the switches on the switch panel of the measuring instrument.

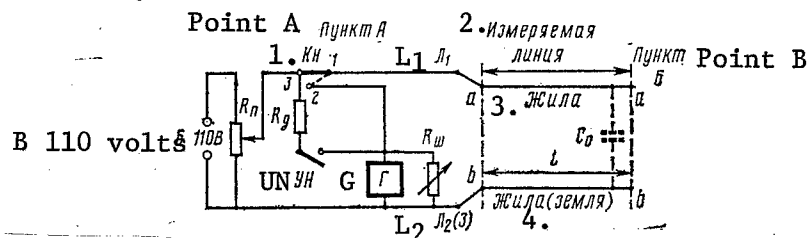

Figure 3.19. Measuring the working capacitance of a circuit.

Key: 1. Pushbutton; 2. Line being measured; 3. Core; 4. Core (ground); G = Galvanometer;  $L_1$  = Line one terminal;

When using the PKP-2M instrument, the measurement circuits are obtained by switching the circuit cores at the instrument terminals. After applying voltage to the circuit being measured for two minutes, the capacitance over the length of the line being measured (the section) is read at the maximum deflection of the galvanometer needle. The circuit capacitance will be equal to the galvanometer reading (graduated in microfarads), multiplied by the scale factor of the instrument.

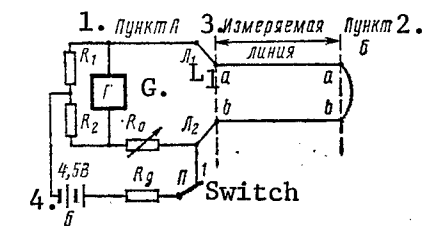

Figure 3.20. Measuring circuit resistance.

Key: 1. Point A; 2. Point B;  
3. Line being measured;  
4. 4.5 volt battery;  
G = Galvanometer.

The circuit resistance is measured in the bridge method using the PKP-2M (PKP-50) or KM-61S instrument (Figure 3.20). Prior to making the measurement, the conductors at the opposite end of the line are connected together. The bridge is balanced by means of variable resistor  $R_0$ . When  $R_1 = R_2$ , the magnitude of the circuit resistance is read directly from the variable resistor, and when  $R_1 \neq R_2$ , it is determined from the formula:

If the measurements are made at a temperature other than  $+20^\circ \text{C}$ , the magnitude of the resistance will be referenced to  $+20^\circ \text{C}$ .

The difference in the resistances of the circuit conductors is determined using the PKP-2M (PKP-50M) instruments by means of a bridge with constant ratio arms. The conductors are connected together and grounded at the opposite end. When the bridge is balanced ( $R_1 = R_2$ ), the value of  $R_0$  is obtained.

If the bridge cannot be balanced, it is necessary to reverse the positions of the conductors at the terminals  $L_1$  and  $L_2$  and repeat the measurement. The magnitude of the difference in the circuit conductor resistances is read directly from the variable resistor  $R_0$ ,  $R_{imb.} = R_0$ .

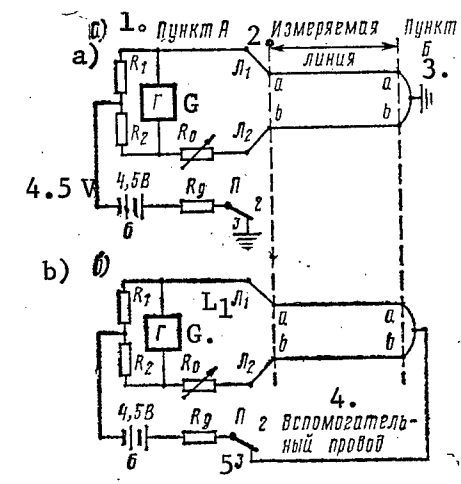

Figure 3.21. Measuring the difference in the resistance (imbalance) of the conductors (cores) of a circuit.

Key: 1. Point A;  
2. Line being measured;  
3. Point B;  
4. Auxiliary conductor;  
5. Grounding switch.

When transient currents are present, an auxiliary conductor of any length, diameter and material (Figure 3.21) is used as a return conductor (ground).

The magnitudes of the difference in the resistances of the circuit conductors should not exceed the norms given in the appendices.

#### Alternating Current Methods for the Electrical Measurements of Lines and Protective Devices

Instruments with balanced or unbalanced inputs with respect to ground, which are connected to the line being measured through shielded balancing transformers, are used for the measurement of the electrical characteristics of lines by means of alternating current. The input impedance of the measurement instruments should be high, or equal to the characteristic or input impedance of the line being measured. The type of instruments to be used is determined by the amount of line noise. If the noise level is 13.0 - 17.3 dB (1.5 - 2.0 Nep) below the expected attenuation, then the application of wideband voltmeters is recommended, and in the converse case, the use of selective level (voltage) meters is recommended. The measurements are made from both ends of the line (the amplified section).

The absolute value of the characteristic impedance of the structural lengths of open air and cable lines with an attenuation of up to 13.0 dB (1.5 Nep) is determined by measuring the input impedances of the circuit under no load (isolated) and when its conductors are short circuited at the far end. In determining the magnitude of the short circuit impedance,  $R_{kz}$ , of the circuit conductors, the switch  $\Pi$  [P] is thrown to position 2-4, and the magnitude of the

voltage is read from the level meter, UU. Then the switch is thrown to position 1-3, and by varying the amount of the resistance of the resistor decade,  $R_{ms}$ , the same readings are achieved on the level meter, UU, as when the switch was thrown to position 2-4.

The magnitude of the resistance of the unloaded circuit is determined just as when measuring  $R_{kz}$  [short circuit resistance], but the circuit conductors are set in the "insulation" position at the far end. The absolute value of the characteristic impedance of the circuit for each measurement frequency is computed from the formula:

$$|Z_{in}| = \sqrt{R_{\text{short circuit}} R_{\text{no load}}} = |Z_B| = \sqrt{R_{ks} R_{xx}}$$

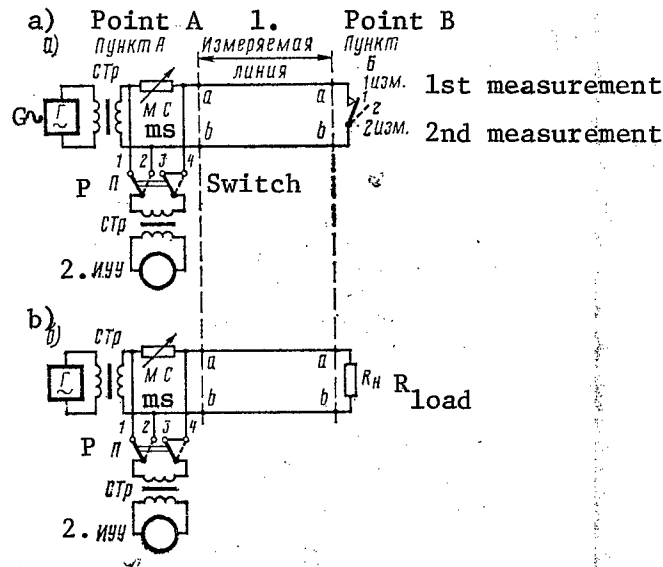

Figure 3.22. Measuring the characteristic and input impedances of a circuit.

Key: 1. Line being measured; 2. Level meters;  
 MS = Attenuator decade; СТр = Balancing transformer;  
 G = Signal generator.

The absolute value of the input impedance of the circuit is measured in accordance with Figure 3.22 under operational conditions for the circuits of multiplexed lines with an attenuation of greater than 13.0 dB (1.5 Nep).

The line being measured is loaded into a resistance at the far end (Figure 3.22) equal in magnitude to the absolute value of the input impedance of the multiplex equipment. By means of the resistor decade, the same readings are obtained on the level meter when switch P is thrown to positions 2-4 and 1-3. The absolute value of the circuit input impedance will be equal to the reading of the resistor decade,  $R_{ms}$ , i.e.  $|Z_{in}| = Z_{ms}$ .

The following instruments are used for the measurements: the UUP-600 (300), 12xN036, IUU-600, IG-300, G-33, STr-300, etc.

The circuit attenuation is measured by means of a generator having any input impedance and two level meters.

An inherent circuit attenuation of up to 13.0 dB (15. Nep) is measured using the circuit shown in Figure 3.23a. The measurement process consists in setting

the load resistances,  $R_{MC}$  [ $R_{ms}$ ] (at points A and B, simultaneously for each measurement frequency) equal to the characteristic impedance of the circuit, and reading the levels  $p_1$  at the transmit and  $p_2$  at the receive ends of the line. In this case, the inherent attenuation of the circuit (for each measurement frequency) will be equal to the difference in the transmit and receive levels:

$$\alpha = p_1 - p_2 - 0.69,$$

where 0.69 is the attenuation introduced into the circuit being measured by the resistance of  $R_{ms}$  (Point A).

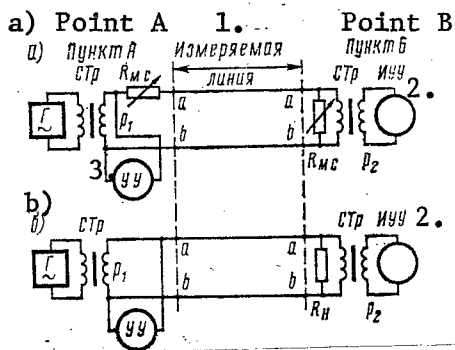

Figure 3.23. Measuring circuit attenuation.

- Key: 1. Line being measured;  
 2. Electronic level meter;  
 3. Level meter;  
 $R_{MC}$  = Variable resistor decade  
 $R_H$  = Load resistance.

An inherent circuit attenuation of greater than 13.0 dB (1.5 Nep) is measured using the circuit of Figure 3.23b. In this case, the circuit is loaded into a constant resistance  $R_H$  [ $R_N$ ] at point B, equal to the absolute value of the characteristic impedance of the circuit or the absolute

value of the input impedance of the multiplex equipment.

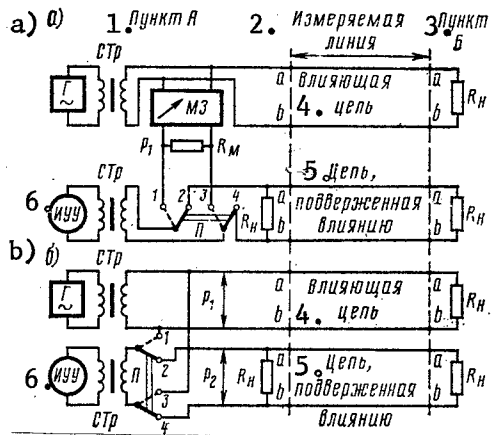

Figure 3.24. Measuring the crosstalk attenuation between physical circuits at the near end of a line.

- Key: 1. Point A;  
 2. Line being measured;  
 3. Point B;  
 4. Interfering circuit;  
 5. Circuit being interfered with;  
 6. Electronic level meter.



The following units are employed in measuring the inherent and working attenuation of a circuit: the IG-300, G-33 (LIG-60), UUP-600 (300), 12xN036, UU-110, IUU-600, MZ-600, 12xN024, Str-300, etc.

The crosstalk attenuation between physical circuits at the near end and the isolation at the far end of a line are measured using the comparison method or the level difference method (Figure 3.24b and 3.25b). The quantities  $A_0$  and  $A_i$  are measured by comparing the level obtained at the output of an attenuator decade with the level at the output of the circuit being interfered with. The attenuator decade is adjusted for identical readings of the level meter at positions 1-3 and 2-4 of switch P. The readings of the attenuator

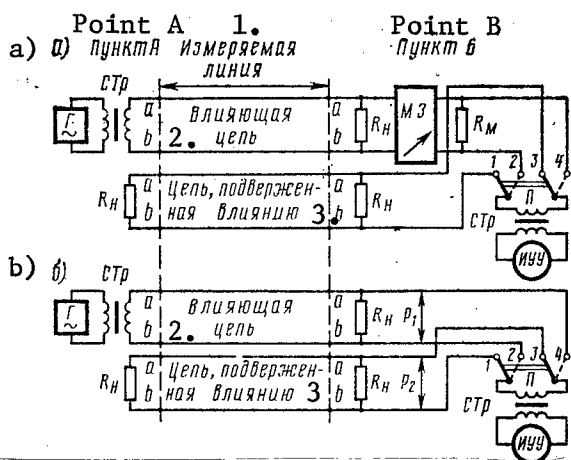

Figure 3.25. Measuring the crosstalk attenuation between physical circuits at the far end of a line.

Key: 1. Line being measured;  
2. Interfering circuit;  
3. Circuit being interfered with;  
MЗ = Attenuator decade.

decade are taken at each measurement frequency.

Measuring the quantities  $A_0$  and  $A_i$  using the level difference method consists in reading the level  $p_1$  in the interfering circuit, and  $p_2$  in the circuit subject to the interference on the level indicator, the IUU (UU). The quantities  $A_0$  and  $A_i$  are computed from formulas at each measurement frequency.

1. The comparison method:

$$A_0 (A_s) = a_{MЗ} \text{ (при } R_{НВ} = R_{НП});$$

$$A_0 (A_s) = a_{MЗ} - \frac{1}{2} \ln \frac{R_{НВ}}{R_{НП}} \text{ (при } R_{НВ} \neq R_{НП}).$$

[ $a_{MЗ}$  = Attenuation of the attenuator decade;  $R_{НВ}$  = Characteristic impedance of the interfering circuit;  $R_{НП}$  = Characteristic impedance of the circuit subject to the interference;  $A_s = A_i$ ]

2. The level difference method:

$$[A_0 (A_s) = p_1 - p_2 \text{ (при } R_{НВ} = R_{НП});$$

$$A_0 (A_s) = p_1 - p_2 - \frac{1}{2} \ln \frac{R_{НВ}}{R_{НП}} \text{ (при } R_{НВ} \neq R_{НП}).$$

The crosstalk attenuation between the phantom and physical circuits at the near end, and the isolation at the far end of a line are measured by the comparison method (Figures 3.26a and 3.27a) or the level difference method (Figures 3.26b and 3.27b) at frequencies of 0.8 and 6.0 KHz. The methods of measuring the quantities  $A_0$  and  $A_1$  for the circuits subject to interference are similar to the measurement methods for the physical circuits, while the calculation is carried out for each circuit using the following formulas:

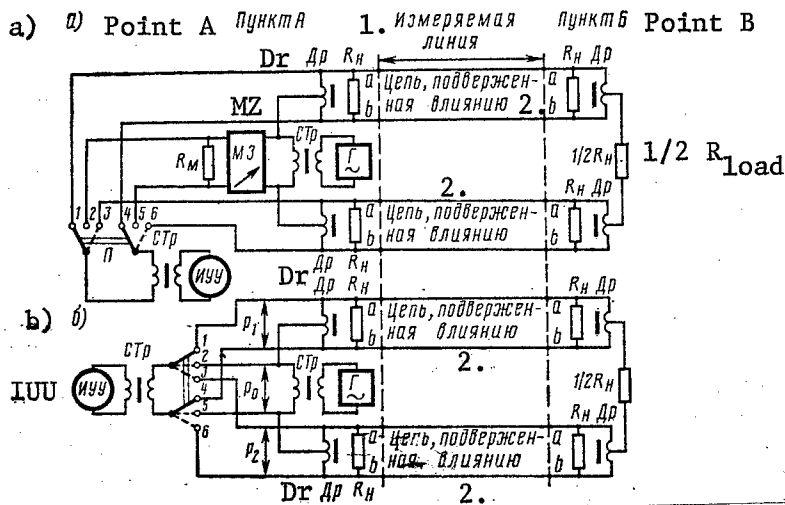

Figure 3.26. Measuring the crosstalk attenuation between a physical circuit and a phantom circuit at the near end of a line.

Key: 1. Line being measured; 2. Circuit subject to interference; Dr = Choke; MZ = MZ = Attenuator decade; IUU = Electronic level meter.

1. The comparison method:

$$A_0(A_s) = a_{MZ} - \frac{1}{2} \ln \frac{R_{НВ}}{R_{НП}}$$

2. The level difference method:

$$A_0(A_s) = p_0 - p_1(p_2) - \frac{1}{2} \ln \frac{R_{НВ}}{R_{НП}}$$

$R_{НВ}$  and  $R_{НП}$  are the load impedances equal to the characteristic impedances of the circuits being measured.

The norms for the crosstalk attenuation and the isolation are given in the appendices.

Used for measuring the crosstalk attenuation and isolation on lines are the following instruments: the KIPZ-300, G-33 (LIG-60), IG-300, UUP-600 (300), IUU-600, MZ-600, MZU-60, 12xN024, a differential audio frequency choke coil, STR-300, STR-IPZ-300, etc.

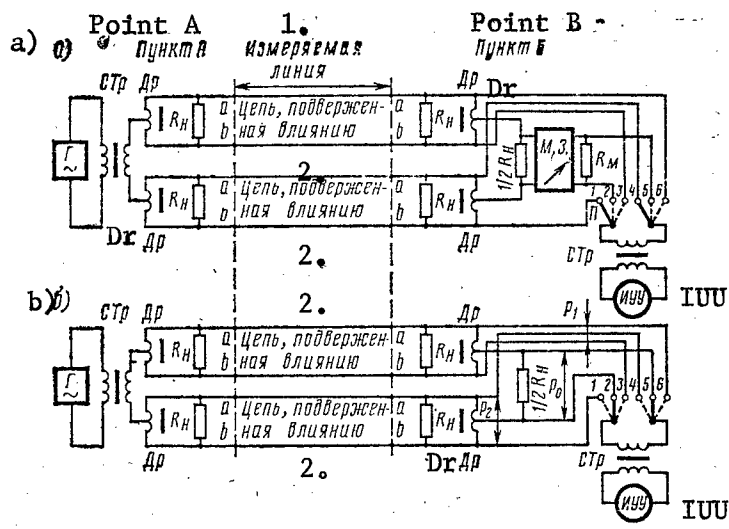

Figure 3.27. Measuring the isolation between phantom and physical circuits at the far end of a line.

Key: 1. Line being measured; 2. Circuit subject to the interference; Др = Choke coil; ИУУ = Electronic level meter;  $R_H = R_{load}$ .

Line noises with a duration of  $200 \pm 50$  msec are measured at both ends of both the physical and phantom circuits for wire communications. The magnitude of the noise is normalized for the length of one amplified section, for multiplexed circuits, and between terminal points for unmultiplexed circuits within the frequency spectrum of one channel.

Those noises which vary their amplitude level within a wide frequency range by a magnitude of no more than  $\pm 2.7$  dB (0.3 Nep) during a measurement period of 0.5 - 1 minute are called smooth noises. Overshoots are characterized by a sharp change in the noise level of 2.7 dB (0.3 Nep) and more within a narrow frequency passband. Overshoots are broken down into regular (which repeat during the greater part of the observation period) and random types. Selective noise has a relatively constant level (roughly  $\pm 2.7$  dB (0.3 Nep) in a frequency range of  $\pm 5$  KHz) during a measurement period of 0.5 - 1 minute. As a rule, selective noise exceeds the noise level in the surrounding frequency range by more than 4.3 - 8.5 dB (0.5 - 1 Nep).

The magnitude of a noise voltage is measured as follows: for smooth noises, in a frequency range of 0.1 - 3.4 KHz and 0.1 - 6.0 KHz using instruments of the 12xN031, UNP-60 (UNP-2) types with a psophometric circuit; in a spectrum of from 0.1 - 20 KHz, using the same instruments without psophometric circuits; for selective, smooth and overshoot noise, in a frequency spectrum of 12 - 160 KHz, using the PCh-1 (IT-13) type microvoltmeter, and others.

The circuit for the measurement of line noise of a physical circuit using a 12xN031 or UPN-60 (UPN-2) instrument is shown in Figure 3.28a. The line being measured is loaded at both ends into resistances,  $R_H$ , the magnitudes of which are equal to the magnitude of the absolute value of the input impedance of the multiplex equipment (for example, 120 ohms for the KNK-6S). Line noises in the phantom circuit are measured using the same circuit configuration, but two cores are taken for one circuit core, i.e. one physical circuit is the wire for the phantom circuit.

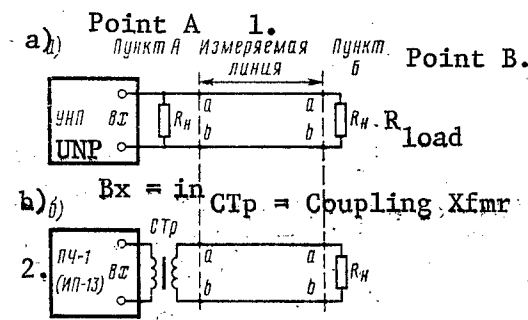

Figure 3.28. Measuring line noise.

Key: 1. Line being measured;  
2. PCh-1 (IP-13)  
UNP = Noise voltage meter

Prior to starting the measurements, it is necessary to make a survey of the entire frequency spectrum from 12 to 160 KHz by means of a selective meter, for example, the PCh-1 (IP-13), and establish the presence of selective noise or overshoots. The magnitude of the noise voltage is read at the maximum deflection of the needle on the galvanometer scale of the instrument, taking into account

the position of the switch lever for the "scale switch":

$$U_n = U_n \text{ meter } A$$

where  $U_n$  is the magnitude of the noise voltage acting within the frequency spectrum being measured;  
 $U_n \text{ meter}$  is the magnitude of the noise voltage read on the scale of the instrument galvanometer;  
A is the magnitude of the factor determined from the position of the "scale switch" lever.

Line noise is measured within the selectivity passband of the instrument, which is equal to  $1.5 \pm 0.1$  KHz in the line spectrum of the channel, using the PCh-1 (IP-13) instrument and others, based on the circuit configuration of 3.28b. Since the input impedance of the instrument is 150 ohms, it is simultaneously a load on the line. As a rule, line noise in the frequency spectrum for high frequency multiplexing is measured at frequencies corresponding to the conversion of the communications channel to frequencies of 800 - 1,000 Hz.

The magnitude of the noise voltage over the width of the line spectrum of one channel is determined from the formula:

$$U_{n c} = U_n \text{ meter } \sqrt{\Delta f_{\text{KHz}}}$$

where  $U_{n c}$  is the noise voltage in the frequency spectrum of one channel having a width of 3.0, 4.0 or 7.33 KHz;  
 $U_n \text{ meter}$  is the measured noise voltage in a part of the channel frequency spectrum 1.5 KHz wide;

$\Delta f_{\text{KHz}}$  is the passband of the line spectrum of the channel frequency, not taken in by the measurement, equal to 1.5, 2.5 or 5.83 KHz.

The magnitudes of the line noise voltage are referenced to units of power into an impedance of 600 ohms for convenience in making comparisons with the set norms.

The power of the noise measurements is computed from the formula:

$$P_n = \ln \frac{U_n}{0.775}$$

where  $U_n$  is the magnitude of the voltage measured by the instrument into a load other than 600 ohms;

0.775 is the magnitude of the voltage measured into an impedance of 600 ohms, taken as the zero level, or a power of 1 milliwatt.

If the magnitude of the noise is measured by a selective instrument, graduated in nepers, then the magnitude of the noise over the spectral width of one channel is determined from the formula:

$$P_{nc} = P_{n \text{ meter}} + \frac{1}{2} \ln \Delta f$$

where  $P_{nc}$  is the noise level in the frequency passband of one channel, for example, 4.0 KHz wide, into a circuit load of 120 ohms;

$P_{n \text{ meter}}$  is the noise level measured by the instrument having a selectivity passband of 1.5 KHz, into a circuit load of 120 ohms;

$\Delta f_{\text{[KHz]}}$  is the difference in the frequency spectrum over the width of one channel which is not taken in by the measurement.

If it is necessary to determine the magnitude of the noise level in a narrow channel passband, for example, over 1.5 KHz, for a known noise level over the width of the channel, for example 7.33 KHz, then the magnitude of the noise level in the 1.5 KHz passband is determined from the formula:

$$P_{n1,5[\text{KHz}]} = P_{nk} - \frac{1}{2} \ln \frac{7,33}{1,5}$$

where  $P_{n1,5 [\text{KHz}]}$  is the noise level in the 1.5 KHz wide passband;

$P_{nk}$  is the norm for the noise level in the 7.33 KHz wide passband;

1.5 KHz is width of the frequency spectrum in which the noise level is determined.

If it is necessary to reference the noise level measured into an impedance other than 600 ohms to a value for the power into a 600 ohm load, the calculation is performed using the following formula:

$$P_n = P_L - \frac{1}{2} \ln \frac{R_L}{600}$$

where  $P_L$  is the noise voltage measured in the passband of the channel into an impedance other than 600 ohms;  $R_L$  is the load impedance of the circuit which is different than 600 ohms.

The magnitudes of the line noise should not exceed the norms given in the appendices.

The attenuation imbalance over the length of a physical circuit at the near end of a line is measured by either the comparison method or the level difference method.

In the case of comparison method measurements (Figure 3.29a), the level of the circuit subject to the interference is compared to the level at the output of the attenuator decade. By varying the attenuation of the attenuator decade, identical readings are obtained from indicator UU in positions 1-3 and 2-4 of switch  $\Pi$ . The magnitude of the circuit imbalance attenuation  $A_a$  (for each measurement frequency) is equal to the quantity obtained on the attenuator decade,  $a_{M3}$ .

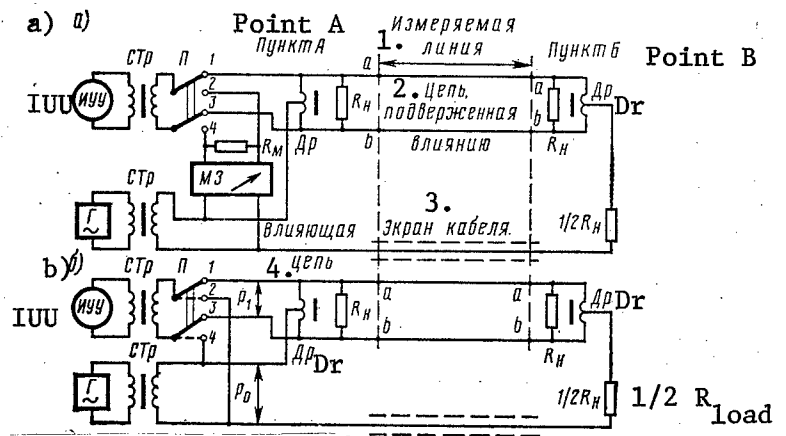

Figure 3.29. Measuring the lengthwise imbalance attenuation at the near end of a physical circuit.

Key: 1. Line being measured; 2. Circuit subject to the interference; 3. Cable shield; 4. Influencing circuit;  $D_r$  = Choke coil; IUU = Level meter;  $\Pi$  = Switch;  $M3$  = Variable attenuator decade.

The measurement circuit for the level difference method is shown in Figure 3.28b. In this case, the level  $p_1$  at the input of the driving (phantom) circuit, and the level  $p_2$  is the circuit being driven are measured. The amount of imbalance for each measurement frequency is determined from the formula:

$$A_a = p_1 - p_2 - \frac{1}{2} \ln \frac{R_{HB}}{R_{HH}},$$

where  $R_{HB}$  and  $R_{HH}$  are the load impedances equal to the characteristic impedances of the circuits being measured.

The imbalance is measured using the following instruments: the KIPZ-300, LIG-60, G-33, ZG-36, IG-300, UU-110, IUU-600, 12xN036, STR-300, STR-IPZ-300, differential audio frequency and high frequency chokes, etc.

The norms for the imbalance attenuation over the circuit length are given in the appendices.

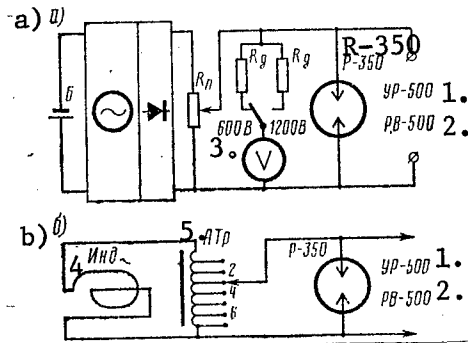

Figure 3.30. Measuring the firing voltage of dischargers.

Key: 1. UR-500; 2. RV-500;  
3. 600 volts;  
4. Magneto;  
5. Autotransformer.

The firing (flashover) voltage of gas filled, carbon, and other dischargers, used as a means of protecting line and exchange installations, is measured using the IR-3 or IR-2 instruments (Figure 3.30a,b).

The IR-3 instrument makes it possible to convert the low DC voltage to a high voltage, as well as smoothly adjust and monitor it on a voltmeter within limits of 250 - 1,100 volts.

The proper operation of the discharger is determined in the following fashion. A standard voltage is fed to its electrodes from a current source. The moment of ignition is established by the monitor voltmeter visually as a sharp decrease in the magnitude of the voltage set initially. Following a sharp decrease in the voltage down to the lower limit, it is automatically increased up to the firing level, and the process indicated here is repeated. The presence of sharp fluctuations in the voltage permits the conclusion that the discharger is in good order.

The IR-2 instrument makes it possible to obtain a voltage of from 220 to 560 volts. The voltages fed from the generator to the autotransformer, ATr, depending on the position of switch P, have the values given in Table 3.70.

TABLE 3.70. The Voltage at the Electrodes of a Discharger

1. Положение переключателя П	1	2	3	4	5	6	7
2. Напряжение на электродах разрядника, В	220	280	340	390	450	500	560

Key: 1. Position of the switch P; 2. Voltage at the discharger electrodes, volts.

A manually cranked generator serves at the alternating current source for the instrument.

The monitor indicator for the checking the insulation resistance of the instrument hook-up, the proper operation of the current generator and the discharger under test is an MN-3 neon lamp. The firing (flashover) of the discharger at a reduced or normal voltage of the current source is established visually from the lighting of the monitor lamp. The absence of lighting of the neon lamp at a specified or increased voltage at the discharge electrode

TABLE 3.71. Firing (Flashover) Voltages of Dischargers

Type of Discharger	Firing (Flashover) Voltage, volts.
R-350	350 ± 40
UR-500	500 ± 100
RV-500	500 ± 100

read on the scale of the galvanometer in a manner similar to that for the MS-08 (07) instrument.

indicates it is not working properly. The firing voltages of various types of dischargers are given in Table 3.71.

The measurement of grounding resistance using the ISZ-2 instrument is shown in Figure 3.31b. The voltage source in the ISZ-2 instrument is an alternating current generator at a frequency of 1,000 Hz. The magnitude of the measured resistance of the ground is

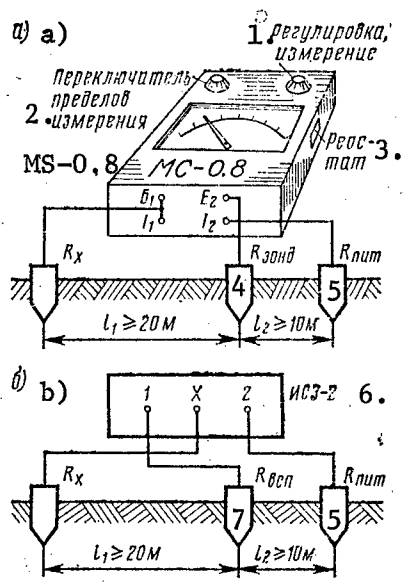

Figure 3.31. Measuring the resistance of grounds.

- Key:
1. Measurement adjustment;
  2. Measurement scale switch;
  3. Rheostat;
  4. R<sub>probe</sub>;
  5. R<sub>supply</sub>;
  6. The ISZ-2;
  7. R<sub>aux</sub>.

The voltage source in the MS-08 (07) instrument is a manually cranked AC generator. The magnitude of the measured grounding resistance is read from the instrument galvanometer, the scale of which is graduated in ohms, taking the position of the scale switch into account.

The measured grounding resistances should correspond to the quantities given in GOST [State Standard] 464-68.

The resistances of grounding devices are measured using MS-08 (07) (Figure 3.31a) and ISZ-2 (Figure 3.31b) instruments. For the measurement of any ground, two auxiliary grounds are rigged, R<sub>probe</sub> and R<sub>supply</sub>, in the form of steel rods 0.7 - 0.8 m long with a diameter of 1 cm at a distance of 20 - 30 m from the ground being measured, R<sub>x</sub>. All external connections between the measurement instrument and the grounds are made with insulated wire.

Processing the Measurement Results of the Electrical Characteristics of Lines



The electrical condition of open wire and cable line communications circuits are evaluated based on the measurement results of their characteristics, referenced to a temperature of +20° C. At an ambient temperature,  $t^\circ$ , when making AC and DC measurements on lines, the following are employed:

- For open wire lines, the temperature of the air, humidity, nature of precipitation (ice, crust, rime ice);
- For cable lines run in the ground, the ground temperature at the depth of cable laying;
- For cable lines run in conduit, the air temperature in the draw-in box at a level of 0.5 m from its bottom;
- For cables run through the outer walls of buildings, as well as for those strung on pillar or post lines, the ambient air temperature.

The measured resistance of a uniform circuit is referenced to a temperature of +20° C using the formula:

where  $R_{t^\circ}$  is the measured magnitude of the circuit resistance at a temperature other than +20° C;  $k_2$  is a factor which depends on the temperature difference determined from the formula,  $1 + \alpha_R(t^\circ - 20^\circ)$ ;  $\alpha_R$  is the temperature coefficient of the metal of the conductors (cores) of the circuit, equal to 0.004 for copper and aluminum, and 0.00455 for steel.

The values of the coefficient for copper and aluminum cores are given in Table 3.72, and for steel conductors, in Table 3.73.

TABLE 3.72. Values of the Coefficient  $k_2$  for Computing the DC Resistance of Copper and Aluminum Conductors (Cores)

$t^\circ$	$k_2$	$t^\circ$	$k_2$	$t^\circ$	$k_2$	$t^\circ$	$k_2$
40	1,080	19	0,996	6	0,944	-7	0,892
35	1,060	18	0,992	5	0,940	-8	0,888
30	1,040	17	0,988	4	0,936	-9	0,884
29	1,036	16	0,984	3	0,932	-10	0,880
28	1,032	15	0,980	2	0,928	-11	0,876
27	1,028	14	0,976	1	0,924	-12	0,872
26	1,024	13	0,972	0	0,920	-15	0,860
25	1,020	12	0,968	-1	0,916	-20	0,840
24	1,016	11	0,964	-2	0,912	-25	0,820
23	1,012	10	0,960	-3	0,908	-30	0,800
22	1,080	9	0,956	-4	0,904	-35	0,780
21	1,040	8	0,952	-5	0,900	-40	0,760
20	1,000	7	0,948	-6	0,896		

TABLE 3.73. Values of the Coefficient  $k_2$  for Computing the DC Resistance of Steel Conductors

$t^\circ$	$\kappa_2$	$t^\circ$	$\kappa_2$	$t^\circ$	$\kappa_2$	$t^\circ$	$\kappa_2$
50	1,137	16	0,982	-2	0,900	-20	0,818
45	1,114	15	0,977	-3	0,895	-21	0,813
40	1,091	14	0,973	-4	0,891	-22	0,809
35	1,068	13	0,968	-5	0,886	-23	0,804
30	1,046	12	0,964	-6	0,882	-24	0,798
29	1,041	11	0,959	-7	0,877	-25	0,795
28	1,036	10	0,955	-8	0,873	-26	0,791
27	1,032	9	0,950	-9	0,868	-27	0,786
26	1,027	8	0,945	-10	0,864	-28	0,782
25	1,023	7	0,941	-11	0,859	-29	0,778
24	1,018	6	0,936	-12	0,854	-30	0,773
23	1,014	5	0,932	-13	0,850	-35	0,750
22	1,009	4	0,927	-14	0,845	-40	0,727
21	1,005	3	0,923	-15	0,841	-45	0,704
20	1,000	2	0,918	-16	0,836	-50	0,681
19	0,996	1	0,914	-17	0,832		
18	0,991	0	0,909	-18	0,827		
17	0,986	-1	0,904	-19	0,823		

The circuit resistance per 1 Km of length is determined from the formula

$$R_0 = \frac{R_{20^\circ C}}{l}$$

where  $R_{20^\circ}$  is the measured magnitude of the circuit resistance referenced to a temperature of  $+20^\circ$  C;  $l$  is the length of the circuit known from the data sheet for the line or the scheduled measurements.

If the circuit is electrically nonuniform, then prior to processing the measurement results, it is necessary to reduce the entire circuit to one value of a circuit length with respect to resistance or diameter (for example, with respect to the resistance (diameter) of the first section from the point of measurement).

Two cases are encountered:

1. The circuit (conductor, core) is electrically nonuniform as regards material. Computing the referenced length of the circuit is carried out using the formula:

$$l' = l_1 + l_2 \frac{z_2}{z_1} + \dots + l_n \frac{z_n}{z_1},$$

where  $l'$  is the referenced length of the circuit;

$l_1$  is the length of the first section of the circuit, to which the length of all remaining sections (inserts) are referenced;

$l_2, \dots, l_n$  are the lengths of the remaining circuit sections;

$z_1$  is the resistance of 1 Km of conductor of the first circuit section;  
 $z_2, \dots, z_n$  is the resistance of 1 Km of conductor of the circuit sections being normalized.

2. The circuit is electrically nonuniform with respect to the diameter, but uniform as regards the material. The calculation of the normalized circuit length is performed using either the preceding formula:

$$l' = l_1 + l_2 \kappa_1 + \dots + l_n \kappa_1,$$

$k_1$  is the factor determined from the formula:

$$\kappa_1 = \left( \frac{d_1}{d_n} \right)^2;$$

$d_1$  is the conductor diameter of the first circuit section  
 $d_2, \dots, d_n$  is the conductor diameter of the normalized circuit sections.

The resistance of the normalized circuit per 1 Km of length is determined from the formula:

$$R_0 = \frac{R_{020^\circ}}{l'},$$

The resistance of the polyethylene insulation of cable cores between each other over a length of 1 Km and for each core with respect to the other cores, connected the shield and ground, is computed from the formula:

$$R_{ins} = R_{meas.} \cdot l$$

where  $R_{meas.}$  is the measured resistance of the core insulation at any temperature of the ambient medium;  $l$  is the length of the circuit, known from the line data sheet.

The resistance of the polyvinylchloride insulation of single pair cables is found from the formula:

$$R_{ins\ 20^\circ} = R_{meas.} \cdot l \cdot k_3$$

where  $k_3$  is the coefficient for calculating the resistance of the polyvinylchloride jacketing (insulation) given in Table 3.74.

TABLE 3.74. Values of the Coefficient  $k_3$  for Calculating the Resistance of the polyvinylchloride Insulation of Single Pair Cables.

$t^\circ, C$	5	10	15	20	25	30
$k_3$	0,1	0,2	0,5	1,0	2,2	4,6

The resistance of paper, air-paper and cotton insulation for cable cores is computed from the formula:

$$R_{ins\ 20^\circ} = R_{meas.} \cdot k_4$$

where  $k_4$  is the coefficient for calculating the resistance of the cable core insulation. The values of the coefficient are given in Table 3.75.

TABLE 3.75. Values of the Coefficient  $k_4$  for Calculating the Insulation Resistance of the Cores of Multipair Type T Cables.

$t, ^\circ\text{C}$	1. $k_4$ для изоляции			$t, ^\circ\text{C}$	1. $k_4$ для изоляции		
	2 хлопчатобумажной	3 бумажной массы	4 воздушно-бумажной		2 хлопчатобумажной	3 бумажной массы	4 воздушно-бумажной
45÷50	46,0	28,85	10,45	5÷9	0,17	0,37	0,51
41÷45	28,0	15,90	6,12	0÷4	0,10	0,24	0,35
36÷40	16,0	8,20	4,04	-1÷-5	0,074	0,17	0,25
31÷35	8,40	5,20	2,79	-6÷-10	0,057	0,13	0,17
25÷30	4,50	3,12	1,94	-11÷-15	0,047	0,094	0,10
21÷25	2,28	1,68	1,37	-16÷-20	0,041	0,074	0,066
20	1,00	1,00	1,00	-21÷-25	0,037	0,056	0,050
15÷19	0,80	0,91	0,94	-26÷-30	0,031	0,042	0,036
10÷14	0,38	0,67	0,72	-31÷-35	0,027	0,032	0,024
				Ниже -35	0,023	0,025	0,018

Key: 1.  $k_4$ , for insulation of: 2. Cotton; 3. Paper mass; 4. Air-paper.

The resistance of paper cording insulation for cable cores is computed from the formula:

$$R_{ins\ 20^\circ} = R_{meas.\ t^\circ} \cdot k_5$$

where  $k_5$  is the coefficient for calculating the insulation resistance of the cable cores. The values of the coefficient are given in Table 3.76.

The resistance of the insulation of the conductors of open air communications lines is determined from the formula:

$$R_{ins} = R_{meas.\ t^\circ}$$

The data obtained are compared with the norms given in the appendices.

The results of measuring the internal attenuation of a cable line circuit are referenced to a temperature of +20° C using the formula:

$$a_{20^\circ} = \frac{a_t}{1 + \alpha_\alpha (t^\circ - 20^\circ)}$$

where  $\alpha_{t^\circ}$  is the attenuation of the circuit measured at a temperature other than +20° C;

$\alpha_\alpha$  is the temperature coefficient of the attenuation of the measured circuit, given in the appendix.

The attenuation factor for the circuit per 1 Km of length is determined from the formula:

$$\alpha = a_{20^\circ}/l,$$

where  $\alpha_{20^\circ}$  is the measured magnitude of the circuit attenuation referenced to a temperature of  $+20^\circ$  C.

TABLE 3.76. Values of the Coefficient  $k_5$  for Computing the Resistance of the Core Insulation for Type TZ Cable with Paper-Cording Insulation

$t^\circ$	$\kappa_5$	$t^\circ$	$\kappa_5$	$t^\circ$	$\kappa_5$	$t^\circ$	$\kappa_5$
35	10,000	15	0,769	-1	0,443	-17	0,311
30	2,500	14	0,735	-2	0,431	-18	0,306
29	2,174	13	0,704	-3	0,420	-19	0,299
28	1,923	12	0,676	-4	0,410	-20	0,294
27	1,572	11	0,649	-5	0,400	-21	0,289
26	1,563	10	0,625	-6	0,391	-22	0,284
25	1,429	9	0,603	-7	0,382	-23	0,279
24	1,316	8	0,581	-8	0,373	-24	0,275
23	1,220	7	0,562	-9	0,365	-25	0,270
22	1,136	6	0,544	-10	0,357	-26	0,266
21	1,064	5	0,526	-11	0,350	-27	0,262
20	1,000	4	0,510	-12	0,343	-28	0,258
19	0,943	3	0,495	-13	0,336	-29	0,254
18	0,894	2	0,481	-14	0,329	-30	0,250
17	0,847	1	0,467	-15	0,323	-35	0,233
16	0,807	0	0,455	-16	0,317		

The attenuation factor for an open wire circuit per 1 Km of length is determined from the formula:

$$\alpha_{[KM]} = \frac{a_{t^\circ}}{l}$$

#### Determining the Distance to the Location of a Circuit Insulation Fault

The following faults are the ones most frequently encountered in operating open wire and cable lines:

- A reduction in the insulation resistance between the conductors (cores) of one circuit, a "short";
- A reduction in the insulation resistance of a conductor (core) with respect to ground (the shield), a "ground";
- A reduction in the insulation resistance between the conductors (cores) of different circuits, a "cross connection";
- A difference in the resistance of the conductors (cores) of a circuit, an "imbalance";
- A break in one or both conductors (cores), or a break in several conductors (cores) of a line;

-- Open conductors (cores) between different circuits on a line.

The location of an insulation fault is determined using a DC bridge with constant ratio arms when one conductor is good and if the diameter and material of the damaged conductor is known, and the lengths of the faulty and good conductors (of any diameter and material) are also known; if the insulation resistance of the good conductor is 100 times greater than the insulation resistance of the faulty one, and the magnitude of the contact resistance,  $R_{\Pi}$ , at the point of the fault is no more than 40 MOhms.

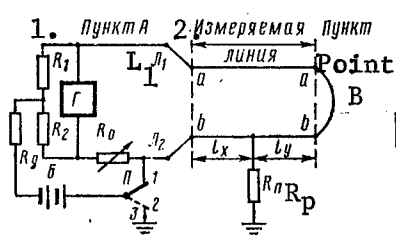

Figure 3.32. Determining the location of an insulation fault in the conductors (cores) of a circuit using a bridge with constant ratio arms.

Key: 1. Point A;  
2. Line being measured;  
 $R_p$  = Contact resistance.

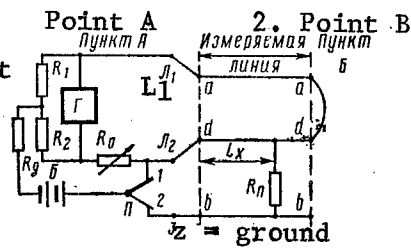

Figure 3.33. Determining the location of an insulation fault in the conductors (cores) of a circuit, a "short" or "cross connection", using a bridge with constant ratio arms.

Key: 2. Line being measured;  
 $\Gamma$  = Galvanometer;  
 $\Pi$  = Switch;  
 $\mathcal{Z}$  = z = Ground.

The location of an insulation fault in a conductor of the "ground" type is determined using the circuit configuration of Figure 3.32, while for a "short" or "cross connection" type, using the circuit configuration of 3.33. In both cases, when switch  $\Pi$  is in position 1, the resistance of the circuit  $R'_0$  is measured, while measured in position 2 is the difference in the resistances (imbalance) of the conductors of the circuit  $R''_0$ . The voltage of the measurement battery is set from 4.5 to 10 volts for the first measurement and in the second, depending on the magnitude of the contact resistance at the fault point, from 4.5 to 500 volts.

The distance from the measurement point to the point of the fault,  $l_x$ , is determined from the formula:

$$l_x = \frac{R'_0 - R''_0}{2r}$$

where  $r$  is the resistance of 1 Km of the faulty conductor, known from the line data sheet or the scheduled measurement documents, referenced to the temperature of the ambient medium.

If the bridge cannot be balanced during the second measurement, then it is necessary to interchange the lines (cores) of the circuit being measured at the terminals  $L_1$  and  $L_2$  of the instrument, and repeat the measurement.

In this case, it is necessary to correspondingly change the sign from minus to plus in the formula for the calculation.

A bridge with variable ratio arms is used when one good conductor is available, where the length, material and diameter of the good and faulty conductors are known; the insulation resistance of the good conductor is 100 times greater than the resistance of the insulation of the faulty one; the contact resistance at the fault location is no greater than 40 MOhms. The measurement circuit for the determination of the location of a "ground" type fault in the circuit insulation is shown in Figure 3.34, while for a "short" or "cross connection" type, in Figure 3.35. One measurement is made in each case. The value of  $R_0$  is obtained when the bridge is balanced.

The distance from the measurement point to the fault location is determined from the following formulas:

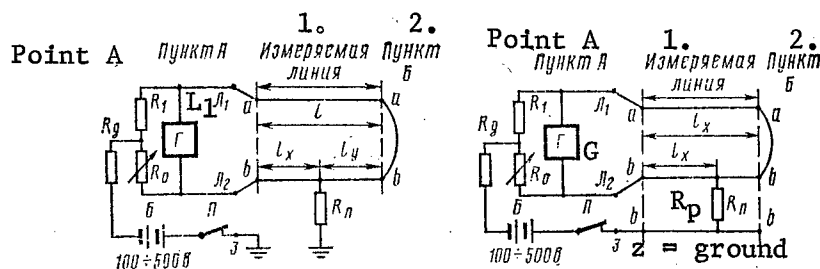

Figure 3.34. Determining the location of an insulation fault in the conductors (pairs) of a circuit, a "ground" by means of a bridge with variable ratio arms:  
 Key: 1. Line being measured;  
 2. Point B;  
 $L_1$  = Line 1 terminal;  
 $R_{\pi}$  = Contact resistance.

Figure 3.35. Determining the location of an insulation fault in the conductors (cores) of a circuit, a "short" or "cross connection", using a bridge with variable ratio arms:  
 Key: 1. Line being measured;  
 2. Point B;  
 $R_p = R_{\pi}$  = Contact resistance;  
 $\Pi$  = Switch;  
 G = Galvanometer.

-- For the case of identical lengths, materials and diameters of the good and faulty conductors of the circuit:

$$l_x = l_k$$

where  $l$  is the length of the faulty conductor;

$$k \text{ is a coefficient equal to } \frac{2R_0}{990 + R_0}.$$

-- For different lengths of the circuit conductors (the faulty conductor being shorter), but identical diameters and materials:

$$l_x = \frac{l_1 + l_2}{2} k$$

where  $l_1$  and  $l_2$  are the lengths of the good and the faulty conductors;

-- For different lengths and diameters of the conductors of the measured circuit (the faulty conductor is shorter and has a greater diameter):

$$l_x = \frac{l_1' + l_2}{2} \kappa,$$

Where  $l_1'$  is the normalized length of the good conductor, which is determined from the formula:

$$l_1' = l_1 \left( \frac{d_2}{d_1} \right)^2 = l_1 \kappa_1,$$

$\kappa_1$  is a factor equal to  $\left( \frac{d_2}{d_1} \right)^2$ ;

$d_1$  and  $d_2$  are the diameters of the good and faulty conductors of the circuit respectively.

The location of a "short" type fault or "cross connection" type, in the absence of good conductors, is determined using a bridge with constant ratio arms in the case where the diameter and material of the conductors are known, but the length of the circuit is unknown; where the magnitude of the contact resistance at the fault point does not exceed 1,000 ohms; and the insulation resistance of the faulty conductors of the circuit with respect to ground (of a core with respect to the cable shield) exceeds the contact resistance at the point of the fault by 50 times.

During the first measurement (Figure 3.36a), the circuit conductors at point B are isolated. The switch  $\Pi$  is thrown to position 1. The measurement result is the value of the resistance  $R_0'$ . During the

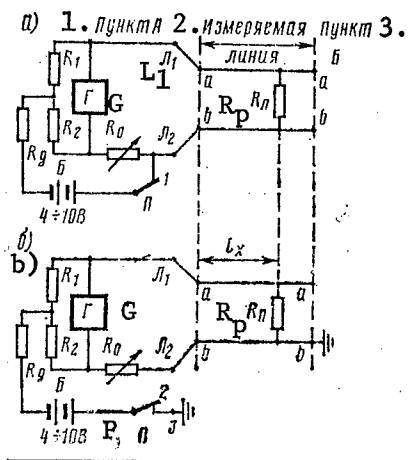

second measurement (Figure 3.36b), one of the circuit conductors is grounded at point B, while the other is insulated. Switch  $\Pi$  is thrown to position 2, and a ground is connected to terminal 3. The conductors being measured are connected to the terminals of the instrument so that the conductor grounded at point B is connected to terminal  $L_2$  of the instrument. When the bridge is balanced, the magnitude of the resistance  $R_0''$  is obtained. The voltage of the instrument battery should be no greater than 10 volts during the measurements.

The distance from the measurement point to fault point is determined from the formula:

$$l_x = \frac{R_0' - R_0''}{2r}$$

Figure 3.36. Determining the location of a fault in the insulation between conductors (cores), a "short" or "cross-connection", using a bridge with constant ratio arms. Key: 1. Point A; 2. Line being measured; 3. Point B.

The location of a "short" or "cross connection" type insulation fault in the conductors can also be determined using the method of no circuit load (isolation) with two-way measurements using a bridge with constant ratio arms according to the



circuit configuration of 3.37, where the resistance of the circuit and its length are known, the contact resistance at the fault point is no greater than 0.1 MOhms, the circuit conductors are uniform and the insulation resistance of each conductor with respect to ground (core to cable shield) exceeds the contact resistance at the insulation fault point by no less than 50 times.

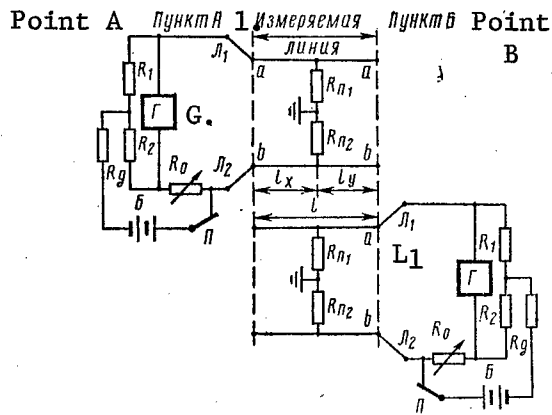

Figure 3.37. Determining the location of a circuit insulation fault between the conductors (cores) and ground, using the no load method with a bridge having constant ratio arms.

Key: 1. Line being measured.

The first measurement is made from point A. The circuit conductors are insulated at point B. When the bridge is balanced, the value of the resistance  $R_0'$  is obtained. The second measurement is made from point B with the circuit conductors insulated at point A. The value of the resistance  $R_0''$  is obtained. The voltage of the measurement battery should be no more than 100 volts during the measurements.

The distance from the measurement point (A or B) to the point of the fault is determined from the following formulas respectively:

$$l_x = l \frac{R_0' + R_n - R_0''}{2R_n};$$

$$l_y = l \frac{R_0'' + R_n - R_0'}{2R_n}.$$

The location of a "short" or "cross connection" type insulation fault is determined by means of a short circuit method for the circuit at the far end of the line with two-way measurements using a bridge with constant ratio arms in accordance with Figure 3.38, given the conditions that the length of the circuit being measured is known, the circuit conductors are uniform; the resistance  $R_{n1}$  is 3 to 10 times greater than the resistance  $R_{n2}$ ; and the magnitude of the contact resistance at the location of the insulation fault is no more than 40 MOhms.

The first measurement is made from point A with the conductors connected together at point B, and the value of the resistance  $R_0'$  is obtained, while the second measurement is made from point B with the circuit conductors connected together at point A, and the value of the resistance  $R_0''$  is obtained.

The distance to the location of the fault is determined from the following formulas respectively:

$$l_x = l \frac{R_0''}{R_0' + R_0''}; \quad l_y = l \frac{R_0'}{R_0' + R_0''},$$

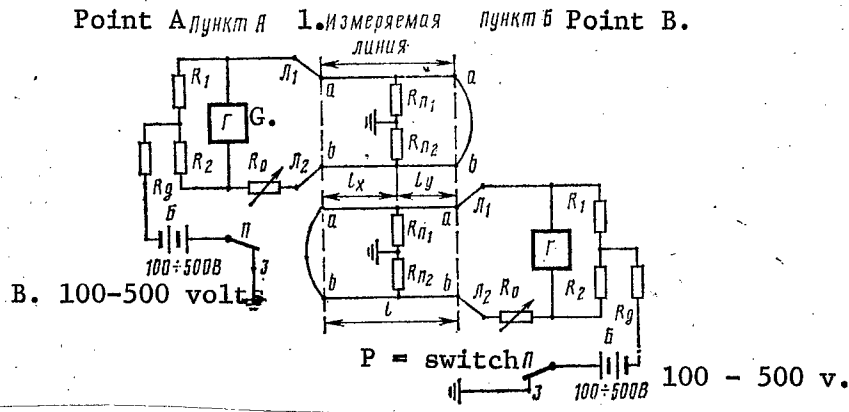

Figure 3.38. Determining the location of an insulation fault in the conductors (cores) of a circuit using a bridge with constant ratio arms.

Key: 1. Line being measured.

The location of a "short" or "cross connection" type insulation fault in the conductors of a circuit is determined using the short circuit and no load methods at the far end of the line, with one-way measurements using a bridge with variable ratio arms in accordance with the circuit of Figure 3.39, given

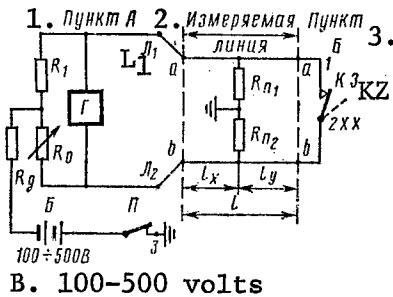

Figure 3.39. Determining the location of an insulation fault between conductors (cores) and ground, using a bridge with variable ratio arms.

Key: 1. Point A;  
 2. Line being measured;  
 3. Point B.  
 KZ = Short circuit;  
 2XX = [Position] 2, no load.

the conditions that the damaged conductors of the circuit have identical characteristics (length, diameter and material); the length of the circuit being measured is known; the resistance  $R_{\pi 1}$  is 20 times greater than the resistance

$R_{\pi 2}$ ; and the magnitude of the contact resistance at the fault point is no more than 40 MOhms.

During the first measurement, the conductors of the circuit at point B are connected together, and, having balanced the bridge, the value of the resistance  $R_0^I$  is obtained, and during the second measurement, the circuit conductors are insulated at point B, and the value of  $R_0^{II}$  is obtained.

The distance to the location of the insulation fault in the circuit is determined from the formula:

$$l_x = l \frac{\kappa' - \kappa''}{1 - \kappa''},$$

where  $\kappa'$  is the coefficient obtained as a result of the circuit measurement when short circuited ( $R_0^I$ ) at point B;

$$\kappa' = \frac{2R_0}{990 + R_0};$$

$\kappa''$  is the same, with the circuit open ( $R_0^{II}$ ) at point B;  $\kappa'' = \frac{2R_0^{II}}{990 + R_0^{II}};$

$l$  is the length of the circuit known from the data sheet for the line.

The locations of insulation faults of the "short to ground" or "cross connection to ground" types in circuit conductors are determined using the short circuit method at the far end of the line with two-way measurement using a bridge with variable ratio arms based on the circuit configuration of Figure 3.40, in those cases where the length of the circuit being measured is known; where the faulty circuit conductors have identical characteristics (diameter, material, length); the magnitude of the contact resistance at the fault point is no greater than 40 MOhms; and the insulation resistance of each conductor with respect to ground (the cores with respect to the cable shield) differ from each other by no less than 30%.

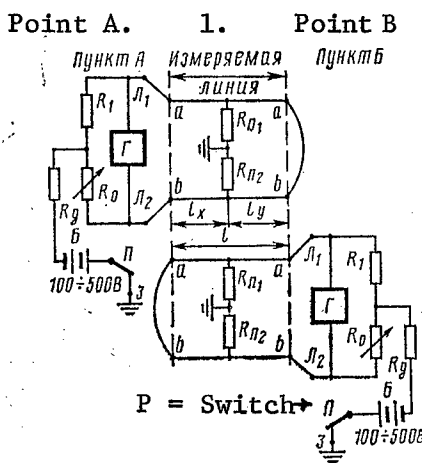

Figure 3.40. Determining the location of an insulation fault with respect to ground for the conductors (cores) of a circuit using a bridge with variable ratio arms.

Key: 1. Line being measured.

In the first measurement (from point A), the wires of the circuit are connected together at point B, and having balanced the bridge, the value of the resistance  $R_0^I$  is obtained; in the second measurement (from point B), the wires are

shorted at point A and the magnitude of the resistance  $R_0''$  is obtained. The voltage of the bridge battery for both measurements should be from 100 to 500 volts.

The distance from the measurement point (A or B) to the location of the fault is determined from the following formulas respectively:

$$l_x = l \frac{1 - \kappa''}{(1 - \kappa') + (1 - \kappa'')} ;$$

$$l_y = l \frac{1 - \kappa'}{(1 - \kappa') + (1 - \kappa'')} ,$$

where  $\kappa'$  is the coefficient obtained from the results of measuring the circuit from point A;  $\kappa''$  is the same, taken from point B.

#### Determining the Distance to the Point of a Break in the Conductors (Cores) of a Circuit

The distance to the point of a break in the conductors of cable lines is determined by two methods, the ballistic and the bridge methods, using a frequency of 3 to 4 Hz, pulsed or induced currents, while on open wire lines, using only the bridge method with a frequency of 800 Hz for the pulsating or pulsed currents.

The ballistic method (Figure 3.41) is employed if there is a good core with the same characteristics (length, diameter, capacitance) as the damaged one, if the insulation resistance of the damaged core with respect to the cable shield is no less than 10 MOhms, and if the length of the damaged core is known. Prior to making the measurement, the cores of the circuit are insulated at point B. During the first measurement, the capacitance of the good core,  $C_{ab}$  is determined, and during the second, the capacitance of the damaged core,  $C_a$ , is determined with respect to the cable shield. To obtain more precise results, the lines at the ends are connected to the shield along with the positioned cable cores.

The distance from the measurement point to the point of the break in the circuit core is determined from the formulas:

-- With a one-way measurement from point A:

$$l_x = l \frac{C_a}{C_{ab}} ;$$

-- With a two-way measurement from points A and B respectively:

$$l_x = \frac{l}{1 + \sqrt{\frac{C_a}{C_b} \frac{C_{ab} - C_b}{C_{ab} - C_a}}} ;$$

$$l_y = \frac{l}{1 + \sqrt{\frac{C_b}{C_a} \frac{C_{ab} - C_a}{C_{ab} - C_a}}} ,$$

where  $C_b$  is the capacitance of the faulty circuit core measured from point B;  
 $l$  is the circuit length known from the line data sheet.

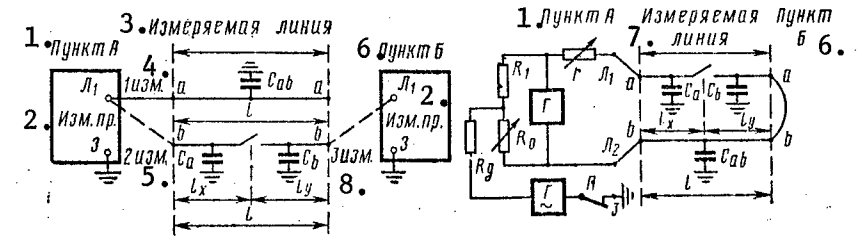

Figure 3.41. Determining the point of a break in circuit conductors using the ballistic method.

- Key: 1. Point A;  
 2. Measurement instrument;  
 3. Line being measured;  
 4. First measurement;  
 5. Second measurement;  
 6. Point B;  
 8. Third measurement.

Figure 3.42. Determining the point of a break in a circuit conductor (core) using an AC bridge with variable ratio arms.

- Key: 1. Point A;  
 6. Point B;  
 7. Line being measured

A bridge with variable ratio arms (Figure 3.42) is used for determining the location of a break in the core of a circuit no more than 3 Km long, or in the conductor of an open wire circuit, using 800 Hz alternating current. The conditions for the application of this method are the same as for the ballistic method. Maximum precision using this measurement method is assured by inserting an additional variable resistor  $r$  (no greater than 200 ohms) in series with the faulty core; by making two-way measurements; and by connecting all cores running along with the faulty one to the shield of the cable at both ends of the line.

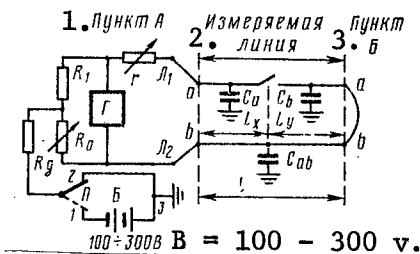

Figure 3.43. Determining the location of a conductor (core) break in a circuit using a bridge with variable ratio arms and pulsating current.

Key: 1. Point A; 2. Line being measured; 3. Point B.

The measurement procedure consists in setting the values of  $R_0$  and  $r$  for minimum sound in the telephone or reading on the level meter, inserted in the bridge circuit in place of the galvanometer.

The distance from the measurement point to the location of the fault is determined from the formula:

$$l_x = l k$$

When the cable length is greater than 3 Km, the point of the break is

determined using a bridge with variable ratio arms by means of a pulsating current (Figure 3.43). The conditions for the measurements are analogous to the conditions for the first two methods. During the measurement process, the battery is switched in and out by throwing switch  $\Pi$  from the first position to the second and monitoring the galvanometer readings. The bridge is balanced by resistors  $R_0$  and  $r$  (up to 1,000 ohms). When a balance of the bridge is achieved, the value of the resistance  $R_0$  is obtained.

The distance to the fault point is determined from the preceding formula.

#### Determining the Distance to the Point of a Difference in the Resistances (Imbalance) of Circuit Conductors.

The location of a difference in the resistances of circuit conductors is determined by two methods: short circuiting the circuit to ground or using a bridge with constant ratio arms and a pulsating current generator; short circuiting and opening the circuit using a bridge with constant ratio arms and an AC generator at 800 Hz.

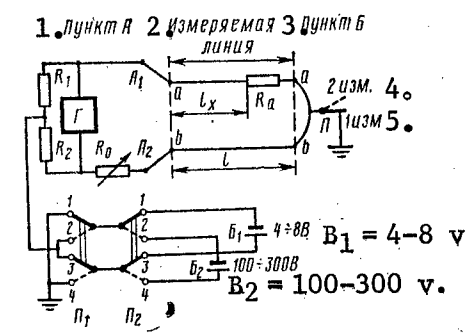

Figure 3.44. Determining the difference in the resistances (imbalance) of the conductors (cores) of a circuit using a pulsating current bridge with constant ratio arms.

Key: 1. Point A; 2. Line being measured; 3. Point B; 4. Second measurement; 5. First measurement.

The bridge method using a pulsating current generator (Figure 3.44) is employed if the length of the cable line is no less than 3 Km, if the circuit length is known, if the insulation resistance of the circuit conductors with respect to ground (cores with respect to the cable shield) is no less than 2 MOhms/Km, and if the circuit conductors are uniform.

The voltage of the battery should be 4.5 - 10 volts for the first measurement, and 100 - 300 volts for the second.

The distance from the measurement point to the point of the fault is determined from the formula:

$$l_x = l \left( 1 - \frac{R_0''}{R_0'} \right),$$

where  $l$  is the circuit length known from the line data sheet.

The location of an imbalance in the circuit conductors is determined using a bridge with constant ratio arms and an 800 Hz generator (Figure 3.45a). This measurement is made when the length of the faulty cable line is no more than 3 Km; there is a current generator and a high impedance telephone or selective level meter available. The other conditions are analogous to the conditions when measuring with a pulsating current generator.

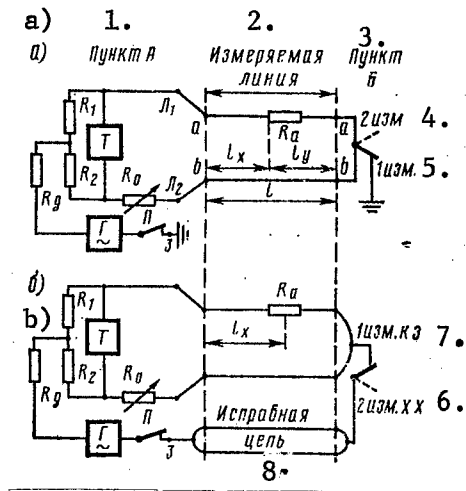

Figure 3.45. Determining the difference in the resistances (imbalance) of the conductors (cores) of a circuit using an AC bridge with constant ratio arms.

- Key: 1. Point A;  
 2. Line being measured;  
 3. Point B;  
 4. Second measurement;  
 5. First measurement;  
 6. Second measurement, open circuit;  
 7. First measurement, short circuit;  
 8. Good circuit.

Two measurements are made: The first when the conductors are shorted together at point B, and the second, when they are insulated. When the bridge is balanced, the values of the resistances  $R_0'$  and  $R_0''$  are obtained. The distance from the measurement point to the point of the fault is determined from the formula:

$$l_x = l \left( 1 - \frac{R_0''}{R_0'} \right).$$

In the presence of stray currents, another good circuit is used in place of the grounds (Figure 3.45b).

#### Determining the Location of a Fault in Circuit Conductors by the Pulse Method

The pulse method of determining the location of a fault is based on the phenomenon of the reflection of short current pulses at the points of the inhomogeneities. The polarity of the reflected pulse indicates the character of the change in the characteristic impedance at the point of the circuit fault. A positive reflected pulse indicates an increase in the characteristic impedance (a break, an imbalance), while a negative one indicates a decrease (a short, ground).

The measurements are made from one end of the circuit using a R1-5A (IKL-5) instrument, and others.

The measurement circuit configuration and the pulse characteristic of a circuit having two conductor discontinuities are shown in Figure 3.46.

The distance from the measurement point to the circuit fault point is determined from the formula:

$$l_{xc} = l \frac{\tau''}{\tau},$$

Figure 3.46. The pulse characteristics and measurement of a uniform circuit loaded into different impedances.

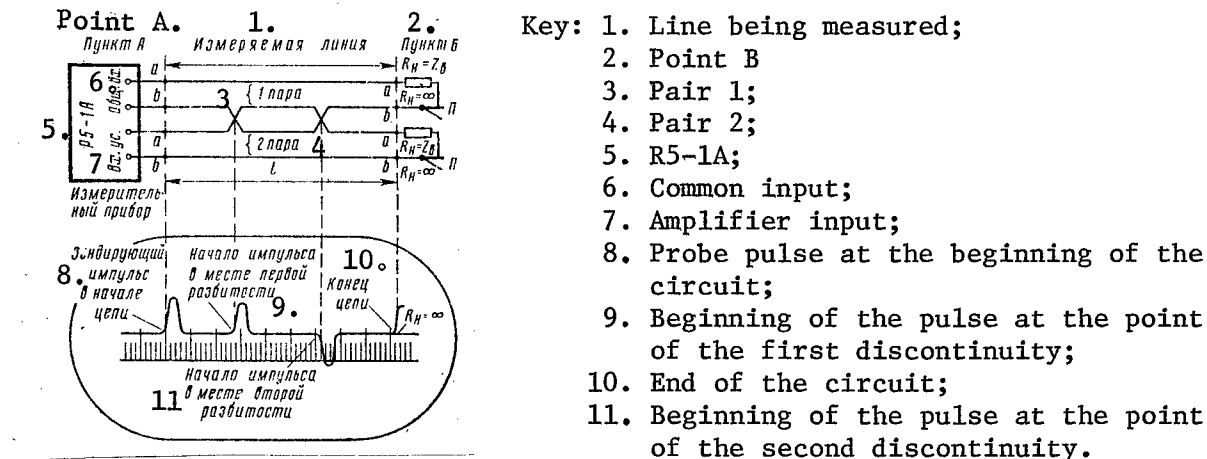

where  $l'$  is the number of divisions read on the screen of the instrument from the beginning of the probe pulse to the beginning of the reflected pulse at the end of the circuit (no load on the circuit);  $l''$  is the number of divisions read on the screen from the beginning of the probe pulse to the beginning of the first, second, etc., reflected pulses;  $l$  is the circuit length known from the line data sheet.

If there are several types of faults on the circuit, they are eliminated sequentially.

#### Finding Cable Routes and Fault Points

The route of a cable and the location of a fault in the cores or shield of a cable are determined using type KI-3 or IPL-4 cable detectors. The inductive method is the basis for operation of the KI-3 instrument, while for the IPL-4, inductive and contact methods are used. The location of a cable fault is determined at any time of the year, for any condition of the ground, and without a precise knowledge of the cable route using the inductive method. The contact method can be used where there is soft and moist soil, and when the cable route is precisely established.

A "ground", "short" or "cross connection" type fault, where the magnitude of the contact resistance at the insulation fault point is no greater than 20 KOhms, is detected using the inductive method, and when the magnitude is 15 - 200 KOhms, using the contact method. In this case, it is necessary to keep in mind that the route of the cable is defined where good cores are present, while a fault of any type can be determined where they are absent.

If there is a "break" and "ground" in the cable circuit, then it is necessary at the outset to restore the core insulation, and then eliminate the "break".



The route of a cable in an underground conduit or in the ground is detected by the inductive method (Figure 3.47). A signal at a frequency of 1,000 - 1,020 Hz is fed into the cable cores.

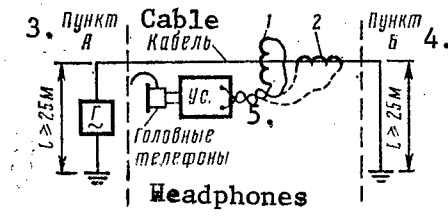

Figure 3.47. Locating a cable route by the inductive method.

- Key: 1, 2 [Search coils];  
 3. Point A;  
 4. Point B;  
 5. Amplifier.

The operator moves along, holding the search coil in front of him at a distance of 5 - 10 cm from the ground, listening for the sound of the generator in the headphones. At the moment it is positioned over the cable, the sound in the headphones will be a maximum or minimum, depending on the position of the coil with respect to the ground. The cable route is determined as a result of listening twice for a maximum and minimum sound.

The locations of "ground" or "break" type faults in cable line cores using the inductive method are detected using the circuit configurations shown in Figure 3.48a. When approaching the fault point, the sound of the generator decreases sharply, while above the fault point and behind it, it disappears.

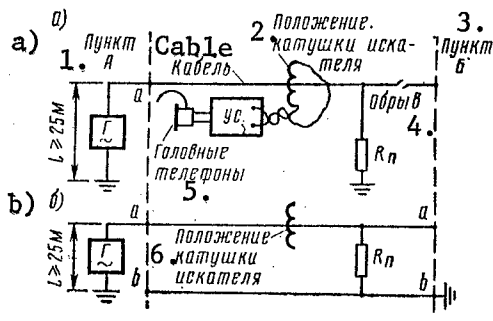

Figure 3.48. Locating the fault points in cable line cores by the inductive method.

- Key: 1. Point A;  
 2. Position of the search coil;  
 3. Point B;  
 4. Break;  
 5. Headphones;  
 6. Position of the search coil.

Searching for a "short" or "cross-connection" type fault location is similar to the search for a "ground" type fault (Figure 3.48b).

The locations of "ground" type faults using the contact method are determined by two operators, using two instruments (Figure 3.49a). The first operator locates the cable route by the inductive method. At a distance of 4-5 m from the first operator, the second makes a search for the fault location, shifting the metal rods of the search instrument (at a depth of 3-4 cm) in the ground, positioning them at a distance of 1-1.5 m from each other over the cable, and listens to the generator for equal loudness. The

generator sound increases sharply over the fault point, and behind the fault point, the sound disappears.

The location of a "short" or "cross connection" type fault is determined by the contact method using the circuit configuration of 3.49b. In this case,

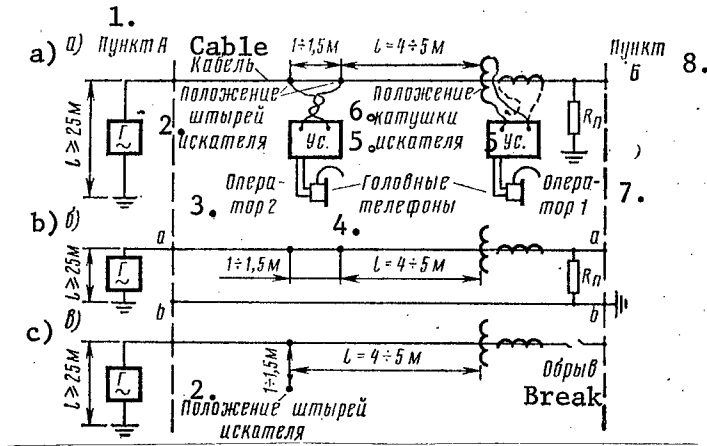

Figure 3.49. Locating the fault points in cable line cores using the contact method.

- Key: 1. Point A;  
 2. Position of the detector rods;  
 3. Operator 2;  
 4. Headphones;  
 5. Amplifier;  
 6. Position of the search coil;  
 7. Operator 1;  
 8. Point B:

one core of the faulty circuit should be grounded at point B and insulated at point A. The procedure for the search is similar to the search procedure for a "ground" type fault.

The locations of "break" faults are detected using the circuit configuration of 3.49c. The first operator locates the route of the cable and the second, using metal rods pushed into the ground, where one is directly above the cable and the second at a distance of 1 - 1.5 m from it, listens for equal loudness from the generator. In approaching the fault point, the generator sound increases sharply and disappears above the fault point and behind it.

### 3.5. MEASUREMENT INSTRUMENTS

#### The PKP-2M Instrument

The instrument is intended for making electrical measurements and determining the locations of faults on wire communications lines. Using the instrument, it is possible to measure:

The DC resistance of a circuit	From 0.1 to 10,000 ohms $\pm$ 0.3%
	From 10,000 to 100,000 ohms $\pm$ 0.5%

Circuit imbalance	Up to 1,000 ohms $\pm$ 0.3%
Insulation resistance	From 0.0 to 300 MOhms $\pm$ 2.5% From 300 to 50,000 MOhms $\pm$ 10%
Capacitance	From 0.005 to 0.4 $\mu$ fd $\pm$ 3% From 0.4 to 4 $\mu$ fd $\pm$ 2%

The distance to an insulation fault or core break point.

The instrument design permits the creation of a bridge circuit with fixed or variable ratio arms, circuits for the determination of the location of a core break using the ballistic method and the bridge method using pulsating current.

The portable instrument is housed in two boxes: placed in one are the bridge, galvanometer, potentiometer, switches and terminals, and in the other, the 3, 4, 5 and 110 volt batteries. The boxes are interconnected with a five conductor cable with a connector plug.

The dimensions of the instrument are 385 x 167 x 287 mm, of the battery box, 308 x 153 x 148 mm.

The instrument weights 9.8 Kg, and the battery box without the power sources weighs 1.7 Kg.

#### The KM-61S Instrument

The instrument is intended for making electrical measurements and determining the locations of faults on wire communications lines. The instrument makes it possible to measure:

The DC resistance of a circuit	From 0.1 to 100,000 ohms $\pm$ 0.2%
Circuit imbalance	From 0.1 to 1,000 ohms $\pm$ 0.2%
Insulation resistance using the milliammeter (ohmmeter)	From 0.01 MOhms to 10,000 MOhms $\pm$ 5% ("10")
Circuit capacitance using the charge-discharge method	From 0.01 to 5 $\mu$ fd $\pm$ 2.3% (of the upper limit of the scale)

Distance to an insulation fault or core break point.

The instrument design makes it possible to create a bridge circuit with constant with constant or variable ratio arms, circuits for determining the locations of insulation fault and core break points in a circuit.

The instrument is made portable in a metal box with a removable cover. When being transported, the instrument is housed in a special packing box.

The instrument can be powered from the AC mains at 24 volts  $\pm$  10%, 36 volts  $\pm$  10%, 220 volts  $\pm$  10%, or from a DC battery with a voltage of 11.5 or 14 volts. The power consumption when powered from the 24 volt, 36 volt and 220 volt AC

mains is no more than 5 VA; when powered from dry batteries or storage batteries, no more than 3 watts.

Included with the instrument is a power supply unit consisting of a rectifier, voltage regulator and converter, which makes it possible to obtain DC at a voltage of up to 500 volts, which is used in measurements of the distance to an insulation fault or core break point in circuits. The dimensions of the instrument are 397 x 329 x 292 mm. The weight is 5.0 Kg.

#### The MEG-9 Megger

The instrument is intended for measuring the core insulation of cable structural lengths, as well as of cable lines during the construction and operational period.

The instrument permits the measurement of the insulation resistance of cable cores within limits of from 1 to 100,000 MOhms at a voltage of up to 150 volts. The basic error of the instrument when measuring quantities up to 1.000 MOhms is no more than 10%, and at 100,000 MOhms,  $\pm 15\%$ . The portable instrument is housed in a metal box with an opening cover and a carrying handle.

The instrument is powered from two ZS-U-30 type batteries. The current consumption is no more than 100 mA.

The dimensions of the instrument (with the lid closed) are 310 x 210 x 175 mm. The weight is around 6.6 Kg, including the power sources.

#### The IPI-1 Insulation Electrical Strength Tester

The instrument is intended for checking the electrical insulation strength of cores over the structural lengths of a cable before laying it, and over the length of an amplified section of an already laid cable. The IPI-1 tester is a low power DC voltage source, running up to 3,500 volts, which can be roughly set in steps of  $350 \pm 50$  volts, and precisely set within the limits of each step at each  $50 \pm 8$  volts. The precision in the setting of the output voltage is  $\pm 2.5\%$ . A block diagram of the instrument consists of three units: the power supply, the converter and the switcher.

The tester provides for the measurement of the leakage in cable insulation to 50  $\mu$ A with an error of no more than  $\pm 10\%$ .

The power supply of the instrument is derived from the AC mains at 50 Hz and 220 volts  $\pm 10\%$ , and 24 volts  $\pm 10\%$ , or from a DC source at a voltage of 12 volts  $\pm 10\%$ . The power consumed from the AC mains is no more than 2 VA, and from a DC source, no more than 3 watts.

The instrument operates at a temperature of from  $-30$  to  $+50^\circ$  C, and a humidity of up to 98%.

The dimensions of the instrument are 325 x 190 x 265 mm. The weight is 9 Kg.

### The IR-3 Discharger Tester

The instrument is intended for testing the firing voltage of gas filled, carbon and other types of dischargers, which are used as protection for wire communications lines. The discharger meter converts the low DC voltage to a high voltage in a range of from 250 to 1,100 volts with the capability of adjustment and monitoring using a voltmeter. The precision in the determination of the flashover voltage of the dischargers at an ambient air temperature of  $+20 \pm 5^\circ \text{C}$  is no less than  $\pm 5\%$  of the corresponding full scale reading. The test voltmeter of the instrument has two measurement scales: from 0 to 600 volts and from 0 to 1,200 volts.

The instrument is powered from one 4.1-MFU-0.7 battery. The current consumption does not exceed 85 mA during operation with the 0 to 600 volt scale, and 170 mA using the 0 to 1,200 volt scale.

The portable instrument is housed in a metal box with an opening cover. The working position of the instrument is horizontal.

The dimensions are 200 x 100 x 120 mm. The weight is 1.9 Kg with the power supply.

### The KIPZ-300 Equipment Complex

The complex is intended for measuring the transmission and crosstalk parameters of physical circuits in a frequency range of from 0.8 to 300 KHz, and for phantom circuits, from 0.8 to 6 KHz.

Included in the KIPZ-300 complex are:

- A LIG-IPZ-300 generator, with a working frequency range from 0.3 to 300 KHz and an output level of no less than 26.0 dB (3 Nep);
- An IPZ-300 crosstalk attenuation meter, from 0 to 138.9 dB (0 - 16 Nep);
- An IN-IPZ-300 (selective) indicator with measurement scales from +26.0 to 104.2 dB (+3.0 - 13.0 Nep);
- Two PL-IPZ line switches;
- Two boxes of detachable and spare parts.

### Characteristics of the Complex:

Near end crosstalk attenuation and isolation at the far ends of physical circuits, without using the PL-IPZ line switchers 0 - 128.9 (0 - 16 Nep) at  $f = 0.8 - 300 \text{ KHz}$

Near end crosstalk attenuation and far end isolation between physical and phantom circuits using the PL-IPZ line switchers 0 - 78.2 dB (0 - 9 Nep) at  $f = 0.8 - 6.8 \text{ KHz}$

Lengthwise imbalance attenuation at the near and far ends of physical and phantom circuits

0 - 69.5 dB (0 - 8 Nep) at  $f = 0.8 - 6.0$  KHz

The attenuation of physical circuits using the loop circuit and comparison methods

0 - 138.9 dB (0 - 16 Nep) at  $f = 0.8 - 300$  KHz.

The measurement error in all cases does not exceed

1.73 dB (+0.2 Nep).

The LIG-IPZ-300 generator and the IN-IPZ-300 indicator are powered from two DC sources (the filament voltage is 6.3 volts  $\pm 10\%$ ; the plate voltage is 220 volts  $\pm 10\%$ ) or from an AC source of 127/220 volts +10%, -15% through converters.

Each instrument of the complex is housed in a metal box with a removable cover.

Dimensions: Generator, 550 x 330 x 284 mm; the indicator, 550 x 330 x 284 mm; crosstalk attenuation meter, 540 x 260 x 285 mm; line switcher, 340 x 258 x 228 mm each; power supply, 340 x 258 x 228 mm.

Weight: generator, 25 Kg; indicator, 20 Kg; crosstalk attenuation meter, 17 Kg; generator and indicator power supplies, 14 Kg each; line switchers, 7 Kg each.

#### The VIZ-3 Instrument

The instrument is intended for measuring the frequency characteristics between circuits, the near end crosstalk attenuation and far end isolation of a cable in a frequency range of from 12 to 800 KHz, when building, balancing and operating communications lines.

#### Instrument Characteristics

The frequency characteristic being measured is displayed on the screen of a cathode ray tube with a diameter of 120 mm.

Working frequency range

12 - 300 and 300 - 800 KHz

Output level of the generator into a 170 ohm load

No less than +26 dB (3.0 Nep) (with respect to power)

Maximum measureable magnitude of the crosstalk attenuation using the indicator; attenuation measurement error

138.9 dB (16 Nep)

Up to 130.3 dB (15 Nep)

No more than  $\pm 1.73$  dB (0.2 Nep)

Up to 138.9 dB (16 Nep)

No more than  $\pm 2.7$  dB (0.3 Nep).

A shift in the frequency bands when the power supply voltage changes by  $\pm 10\%$  amounting to no more than 300 KHz is permitted (compensated by manual adjustment of the frequency shift and the width of the band by  $\pm 50$  KHz).

When the attenuation of the interfering circuit is no more than 69.5 dB (8 Nep), the measurements of the far end isolation between circuits are made up to 69.5 dB (8 Nep):

Input of the generator and indicator	Transformer, balanced with respect to ground
Input impedance of each	170 Ohms $\pm 10\%$
Duration of one sweep of the generator frequency	Around 4 seconds

The instrument is powered from 6.5 and 220 volt type 7-NKP-60 storage batteries or from the AC main at 127 or 220 volts with permissible fluctuations of  $\pm 10\%$ . The power consumption is:

When powered from the DC source:

For the generator, 100 mW (220 volts) and 2 watts (6.5 volts)

For the indicator, 75 mW (220 volts) and 3.5 watts (6.5 volts)

When powered from the AC source:

For the generator, 45 VA

For the indicator, 55 VA.

The AC instrument is housed in two metal boxes (generator and indicator). When transporting them, they are placed in wooden packing boxes, in which the various connecting cables and spare parts are also packed.

The generator dimensions are 350 x 260 x 200 mm, and those for the indicator, 280 x 420 x 490 mm. The weight of the generator is 14 Kg, and the indicator, 29 Kg.

The PCh-1 (IP-13) Noise Level Meter

The instrument is intended for measuring the noise on wire communications lines. It takes the form of a selective, high frequency microvoltmeter.

Instrument Characteristics:

Tuned within a frequency range of	12 - 160 KHz (the range is broken down into five sub-bands in the meter)
Instrument sensitivity	1 - 100,000 microvolts
Passband	1.5 $\pm$ 0.1 KHz
Input	Unbalanced with respect to ground, its impedance is 150 ohms.

Peak values

Read on the monitor indicator (microvoltmeter) taking into account the scale factor for the instrument switch position.

A special audio monitor channel is provided in the instrument circuitry, into which a headset can be connected, for listening to the nature of the noise when making measurements.

Power is supplied from the AC mains at 50 Hz and a voltage of 127/220 volts  $\pm 10\%$ ,  $-15\%$ , or from DC sources, a battery pack attached to the instrument.

The portable instrument is housed in a metal box with a removable cover and a shoulder strap for carrying it.

The dimensions are 300 x 180 x 450 mm. The weight is 8 Kg.

The G-33, LIG-60, IG-300, ZG-36, LIG-IPZ-300, etc., Signal Generators

Measurement generators are used as a source of sinusoidal AC signals when measuring the transmission and crosstalk parameters of hard wire communications circuits. In wire communications engineering, vacuum tube signal generators are used which operate in a frequency spectrum of from 0.06 to 300 KHz.

Characteristics:

Input	Balanced with respect to ground
Input impedance	135 and 600 ohms
Maximum power level at the output	Up to +26 dB (3.0 Nep)
Frequency stability and setting accuracy	No less than 0.3%
Nonlinearity suppression	Not less than 34.7 dB (4.0 Nep)
Long term frequency drift	No more than $\pm 0.04\%$ .

The power supply for the G-33 (LIG-60) and LIG-IPZ-300 generators is derived from AC sources at 127/220 volts  $+ 10\%$ ,  $- 15\%$ , or using DC at 6.3 and 220 volts, or 24 and 220 volts (LIG-IPZ-300) through divider resistors, and 24 and 220 volts (G-33 and LIG-60).

Each generator is housed in a metal box convenient for carrying and designed for being carried on any type of transport.

The UNP-2 (UNP-60) and 12xN031 Noise Voltage Meters

The instrument is intended for the quantitative evaluation of the noise appearing in telephone circuits and wire broadcast circuits. The instruments consist of a vacuum tube microvoltmeter with a square law detector, which



sets a time constant close in quantity to the time constant of the human ear, two filters which impart a frequency response characteristic to the vacuum tube voltmeter such as recommended by the MKKTT [International Consultative Committee on Telephony and Telegraphy] for a telephone channel or a wire broadcast channel; a telephone headset for monitoring the character of the noise in the audio monitoring channel during the measurement. With the filters switched in, the instrument is used as a vacuum tube voltmeter to measure the effective values of the voltage in a frequency range of 30 to 20,000 Hz.

Instrument Characteristics:

Range of measureable voltages	From 0.01 $\mu$ V to 10 volts
Instrument integration time	200 $\pm$ 50 msec
Input	Balanced with respect to ground
Input impedance	600 ohms $\pm$ 5%, or high impedance (greater than 8 KOhms)

The UNP-2 instrument is powered from two DC batteries:

- The filament circuit (8 type ZS-L-30) elements at a voltage of 12 volts;
- The plate circuit (two type BAS-80 batteries) at a voltage of 160 volts.

The 12xN031 instrument is powered from the AC mains at a voltage of 127/220 volts  $\pm$ 10%, -15%, while the UNP-60 is powered from AC sources at a voltage of 127/220 volts  $\pm$ 10%, -15%, or using DC at 21.2 volts  $\pm$  3%, or 24 volts  $\pm$   $\pm$  10%.

The UNP-2 instrument is housed in three metal boxes, the overall weight of which along with the power supplies is no greater than 60 Kg.

The UNP-60 and 12xN031 instruments are each housed in a metal box with dimensions of 540 x 260 x 300 mm and 495 x 233 x 365 mm respectively. The weight of the UIP-60 is 18 Kg, and the 12xN031 is 27 Kg.

The UU-110 Level Meter

The instrument is intended for measuring voltage levels, as well as the working and crosstalk attenuation, and in conjunction with an external high frequency attenuator decade, for measuring the absolute value of impedances. Additionally, it can be used as an instrument amplifier with a gain of no less than 3.5 Nep when the amplifier output is loaded into 600 ohms.

Instrument Characteristics:

The operational frequency range	0.05 - 110 KHz
Measurement limits	+26.0 to -60.8 dB (+3.0 to -7 Nep)

Output impedances:

High impedance	Greater than 15,000 ohms
Low impedance	600 - 30 ohms

The instrument error at 1,000 Hz for the extreme right scale marker does not exceed + 0.04

Isolation attenuation 60.8 dB (7.0 Nep)

Imbalance attenuation at this frequency, no less than 43.4 dB (5 Nep).

The instrument is powered from DC sources at a voltage of 24 volts  $\pm$  10% (the battery positive is grounded) and 220 volts  $\pm$  10% (the battery minus is grounded), or from the AC mains at a nominal voltage of 127/220 volts  $\pm$ 10%, -15%.

The instruments consists of a level meter, an attenuator decade and a device for measuring working and crosstalk attenuations, as well as the absolute value of the characteristic impedance of a circuit, using an external attenuator decade, where the level meter is used as an indicator.

The instrument is mounted on a metal panel and is housed in an iron box.

Dimensions: 485 x 340 x 255 mm. Weight: No more than 23 Kg.

The UUP-600 (UUP-300), and 12xN036 Semiconductor Level Meter

The instrument is intended for measuring signal levels from 0.2 to 600 KHz on wire communications lines. The instrument permits the measurement of voltage or power at a level of +26.0 to -60.8 dB (+3.0 to -7.0 Nep).

Instrument Characteristics:

Input impedance	135, 600 ohms, or high impedance
Input	Transformer, balanced with respect to ground
Imbalance attenuation of the instrument input transformer	No less than 39.0 dB (4.5 Nep)
Overall error of the level meter in the operational frequency range on all scales	No more than 0.6 dB (0.07 Nep).

The instrument is powered from three dry batteries of the 4.1-FMTs-07 (or 3.7-FMTs-0.5) type at a voltage of 11 - 14 volts, which are housed in the instrument, or from an external 24 volt DC source or 220 volt AC source. The power consumed by the level indicator is no more than 6.0 milliwatts.

The instrument is housed in a metal box with a removable cover.

The instrument dimensions: 260 x 180 x 135 mm. The weight is about 4 Kg.

#### The TR-LLZ-300 Shielded Balancing Transformer

The instrument is intended for reducing the AC imbalance with respect to ground in measurement instruments and various electrical circuits, as well as for the shielding and isolation of one electrical circuit from another.

#### Instrument Characteristics:

Transformation ratio	1:1
Insulation resistance between the windings, as well as between each winding and the frame	No less than 100 MOhms
Absolute value of the characteristic impedance on the input side when the output is loaded into an impedance of 600 ohms	600 ± 5% in the operational frequency range
Operational attenuation in a frequency range from 0.2 to 300 KHz	No more than 0.2 dB (0.03 Nep).
Longitudinal imbalance attenuation in the frequency range indicated	No less than 78.2 dB (9 Nep).

The transformer is housed in a metal box with a removable cover.

Dimensions: 168 x 156 x 117 mm. The weight is 1.7 Kg.

#### The MS-08 Ground Meter

The instrument is used for measuring the resistance of grounding devices, determining the specific resistance of the earth and the resistances of conductors within limits of from 0 to 1,000 ohms. The instrument has three measurement ranges: From 0 to 1,000 ohms, from 0 to 100 ohms, and from 0 to 10 ohms. The measurement error does not exceed ± 1.5% of the quantity being measured. Extraneous currents at a frequency of 45 - 55 Hz, and DC, have no effect on the error. The measurement of a resistance is based on the ammeter and voltmeter method.

The instrument has four terminals: Two current terminals,  $I_1$  and  $I_2$ , and two voltage ones,  $E_1$  and  $E_2$ , for the connection of two auxiliary grounding electrodes and one being measured.

The instrument is powered from a generator rotated by hand at a speed of from 90 to 135 r.p.m.

The instrument is housed in one box, placed in a special container having a shoulder strap.

The instrument dimensions: 192 x 244 x 455 mm. The weight is 12 Kg.

#### The ISZ-2 Ground Resistance Meter

The instrument is intended for measuring the resistance of line grounding electrodes, as well as for the measurement of other types of resistances, for example, the internal resistance of a current source, etc.

The operation of the instrument is based on the compensation method using an internal 1,000 Hz source. The instrument makes it possible to measure resistances within limits of from 0 to 150 ohms with an error not exceeding 3%. A pointer type galvanometer serves as the indicator determining the sound minimum (reading maximum) when measuring a ground resistance. The diffusion of the minimum (maximum) of the readings on the indicator does not exceed  $\pm 2$  scale divisions of the variable resistance. The noise immunity of the meter is characterized by a reduction in the readings of the meter needle of no less than 50 times when the frequency of the input signal changes from 50 to 1,500 Hz with the same voltage at the input. The instrument is powered from a flashlight battery of the 4.1-FMTs-07 type.

#### The 12xU24 and MZ-600 Attenuator Decades

The instrument is used for adjusting the level of a signal generator operating in a range up to 600 KHz. The attenuation error of the decade does not exceed:

- 0.002 Nep: For an attenuation of from 0.08 to 0.09 dB (0.01 to 0.1 Nep);
- 0.015 Nep: For an attenuation of from 0.9 to 8.5 dB (0.1 to 1.0 Nep);
- 0.2 dB (0.03 Nep): For an attenuation from 8.5 to 43.4 dB (1.0 to 5.0 Nep);
- 0.43 dB (0.05 Nep): For attenuations from 43.4 to 138.9 dB (5.0 to 16.0 Nep).

#### Attenuator Decade Characteristics:

Attenuator input impedance                      600 Ohms

The attenuator decade is balanced with respect to ground, and the attenuator imbalance with respect to the attenuation does not exceed, in terms of the nominal magnitude,                      0.08 dB (0.01 Nep)

The maximum permissible power level at the attenuator decade input should not exceed                      34.7 dB (4.0 Nep).

Located on the front panel of the attenuator decade are terminals (jacks) for "input" and "output", terminals for connecting the ground, the load impedances and switches for the attenuation quantities. The instrument is housed in a metal box. The weight is 7 Kg.

## The R1-5A (IKL-5) Pulse Tester for Lines

[This unit is] intended for determining the character of a fault and the distance to it on open wire and cable wire communications lines.

The following distances can be measured using the instrument:

- To the location of an insulation fault in the conductors (cores) of a circuit with respect to ground (a "ground"), and in the insulation between conductors (cores) of different circuits (a "cross connection");
- To the location of a fault in the insulation between the conductors (cores) of one circuit (a "short");
- To the location of a break in a conductor (core) with a reduction in the insulation or without insulation;
- To the location of a difference in the resistances of circuit conductors (cores) (imbalance);
- To the point of an unpaired connection (discontinuity) of the conductors (cores) in circuits;
- To the point of complex faults, consisting of a combination of faults (break, insulation break, poor contact, imbalance, etc.);
- To the point where water is located between the core insulation and the strip insulation of a cable.

The instrument is powered from the AC mains at a voltage of 127/220 volts, + 10, - 15%, at a frequency of 50 Hz, or from a DC source at 24 volts  $\pm$  10% through a PPT converter. In this case, the instrument's power consumption is 150 watts.

The R1-5A instrument is housed in two metal boxes: Placed in one is the main measurement instrument, and in the other, the AC converter. The boxes are connected together and to the power sources with special cables having plug connectors attached to the instrument.

The dimensions of the instrument: 310 x 350 x 500 mm. The weight is 23 Kg.

## The IPL-4 Cable Detector

The instrument is intended for finding faults in underground cables with polyvinylchloride or polyethylene jacketing using both the inductive and the contact method. Using the inductive method, the instrument makes it possible to determine the route and burial depth of a cable, a break in the cores, an insulation breakdown between the cores of one circuit (a "short") and between the cores of different circuits (a "cross connection"), as well as an insulation breakdown of the cores with respect to ground (a "ground"). Using the contact method, the instrument makes it possible to locate the place of a core break, an insulation breakdown between the cores of one circuit (a "short"), between the cores of different circuits (a "cross connection"), and of the cores with respect to ground (a "ground").

The IPL-4 instrument consists of;

- A signal generator at a working frequency of 1,000 Hz  $\pm$  20% and a pulse repetition rate of 1 to 6 Hz, a power of no less than 0.8 watts into a long line and 0.2 watts into a short line;
- An amplifier with a gain of no less than 60.8 dB (7.0 Nep);
- A search coil;
- Two contact rods and headphones.

The instrument generator is powered from three type 4.1-FMTs-0.7 batteries, while the detector (amplifier) is powered from two 1.5-SNMTs-0.6 cells. The generator uses from 80 to 180 mA of current from the power supply (depending on the length of the line), and the detector (amplifier) uses no more than 8 mA.

The generator is housed in a metal box with a lid which opens up during operation and a handle for carrying it; there is a special battery compartment in the box.

The detector consists of: an amplifier, a remote coil, rods and headphones. The detector is placed in a canvas bag with a shoulder strap.

The generator dimensions: 230 x 130 x 200 mm; the detector dimensions: 1,045 x x 225 mm.

The weight of the generator with the working battery set is no more than 2.3 Kg, and for the detector, no more than 1 Kg.

#### The KI-3 Cable Detector

The cable detector is intended for locating faults on cable lines using the inductive method by means of a remote inductance coil, where these cable lines are run in telephone conduit, the ground, strung on open wire line support poles, run in walls of buildings, as well as over the structural lengths of cables.

The instrument permits:

- Finding the route of a layed cable;
- Determining the depth at which the cable is buried;
- Finding the location of a break in the cable cores, an insulation breakdown between the cores of one circuit (a "short"), between the cores of different circuits (a "cross connection"), and between the cores and ground (a "ground").

Included in the instrument complex are:

- A signal generator at a frequency of  $1,020 \text{ Hz} \pm 2.5\%$ , the output power of which is no less than 1.3 watts. The generator can feed signals continuously or at set intervals;
- A detector with an audio frequency amplifier installed in it, having a gain of 60.8 dB (7.0 Nep).

A ferrite antenna, which is secured in the working position to a contact rod, is connected to the amplifier input. Connected to the amplifier output are type TON-2 headphones. A provision is made in the detector for the capability of working with narrow and wide passbands of 75 - 175 Hz, and 200 - 400 Hz respectively.

The generator is powered from the AC mains at a voltage of 220 or 24 volts, or from 10 type FMTs-U-3.2 cells at 1.6 volts each, connected in series, or from any external DC source at a voltage of 12 - 15 volts. The detector is powered from two 1.5SNMTs-0.6 cells, connected in series. The current consumption does not exceed 5 mA.

The generator is housed in a metal box, in which there is a special compartment 10 type 1.6FMTs-U-3.2 cells.

The detector consists of an amplifier, a tuned circuit with a ferrite antenna, rods and a power supply. The detector, rods and search coil are kept in a canvas bag with shoulder straps for carrying them.

The dimensions of the generator are 240 x 168 x 200 mm; and of the search coil, 1,030 x 200 mm.

The weight of the generator with the working battery set is no more than 4.5 Kg; and of the detector, no more than 1 Kg.

#### A Mobile Instrumentation and Alignment Laboratory

For the operational monitoring of the technical condition of HF multiplex equipment, line installations and channels, and performing operational measurements of the electrical transmission characteristics of channels located on the territory of an operational engineering communications unit for rural telephone networks, the "Pinal" mobile instrumentation alignment laboratory is employed.

The mobile laboratory makes it possible to carry out the following:

- Measurements of the electrical transmission parameters of line units for both DC and AC in a frequency range of from 0.3 to 300 KHz;
- Measurements of the electrical transmission characteristics of HF multiplex equipment in a frequency range of from 0.3 to 300 KHz, telephone channels in a frequency range of from 0.2 to 3.5 KHz, and wire broadcast channels in a frequency range of from 0.1 to 6.5 KHz;

- Adjustment and alignment of the equipment of automatic telephone exchanges of the relay, relay-unit crossbar, and ten-step types;
- Measurements of the resistances of line and exchange grounds at monitor and cable posts, terminal and intermediate HF multiplex exchanges, telephone exchanges, and wire broadcast junctions;
- Check of the line protection elements in the cable boxes of the HF multiplex equipment, and the cable boxes of the telephone network input switching units (VKU's).

The "Pinal" instrumentation laboratory is built up using the following instruments and equipment: a UAZ-452 motor vehicle with equipment; with measurement instruments (the basic set, the remote set, and general use instruments) and tools.

The measurement instruments of the basic set are intended for measuring the transmission parameters of HF multiplex equipment, line units, equipment and wire broadcast lines.

This set consists of: a signal generator with a frequency range of 0.3 to 300 KHz, of the IG-300 type, a wide-band level meter with a passband of from 0.2 to 600 KHz of the IU-600 type; a selective level meter with a passband of from 5.0 to 300 KHz of the IUU-300 type; a control switching panel of the 12XR007A type for organizing the work area (in the vehicle) for the AC measurement of certain line transmission and equipment parameters; a portable cable instrument with power supply, of the PKP-2M type; and a 12XN024 attenuator decade.

The remote instrument set of the laborator, depending on the purpose, consists of several groups of instruments. To organize a remote work location at the other end of a line being measured or channel, the following are used: a signal generator with a frequency range of from 0.3 to 200 KHz of the GZ-36 type; a R-33 resistance decade; a 12x036 level meter with a frequency range of from 0.2 to 300 KHz, with a power supply unit.

To measure nonlinear distortion, noise voltages, and to observe the shape of the signal and the character of the noise in the channel, in a wire broadcast amplifier and in HF multiplex equipment, the following are used: a nonlinear distortion meter of the S6-1 (INI-12) type; a UNP-60 or 12x31 noise voltage meter; and VM-370 oscilloscope.

To make measurements of the electrical transmission characteristics of the amplifiers of radio relay centers and wire broadcast lines in a frequency range of from 0.1 to 6.5 KHz, the following instruments are used: a GZ-36 signal generator with a frequency range of from 0.02 to 200 KHz; a VK-7-9 (AChM2) AC voltmeter; a VZ-10 AC voltmeter; and a set of equivalent loads.

The following instruments are used to carry out alignment and measurement work on automatic telephone exchange equipment: a IDIR decatron pulse time meter with a transducer (of the pulses) and a device for checking polarized relays; and an inductive dial pulse converter.



Included in the general use complex of instruments are: a Ts-435 ammeter - voltmeter; a L2-1 instrument for checking transistor parameters; a meter for the signal voltage at the input terminals of wire broadcast units; a MS-08 or ISZ-2M ground resistance meter; a TR-3 discharger tester; a LATR-2M voltage regulator for 2A.

The electrical equipment of the laboratory makes it possible to power the instruments, provide lighting, maintain a normal temperature and provide for the operation of ventilation units from the external AC mains at a voltage of 220 volts, and power the devices and instruments indicated above in the emergency mode from a 24 volt storage battery, and in this case, a DC 24/220 volt converter is used for powering the plate circuits of the instruments.

Included in the electrical equipment complement of the laboratory are: a distribution panel, storage battery consisting of two 6ST-54-EM storage batteries, one of which is included in the motor vehicle complex, and the other is installed additionally, three reels of cable, of which one is used for connecting the electrical equipment of the laboratory to the external AC mains, and two reels of cable for connecting the facility being measured (line, NUP [unattended amplifier station], multiplex equipment terminal station) to the measurement work location housed in the motor vehicle, as well as the illumination lighting.

If the measurement instruments of the laboratory do not correspond to the task at hand (low sensitivity, limited frequency range of a signal generator or level meter, or the requisite instruments are lacking) for the facility measurements, it is necessary to outfit the laboratory with other instruments compatible as regards the power and type of current and voltage levels of the electrical equipment.

Setting the work location and using it should be carried out with the chassis of the motor vehicle grounded. Grounding is accomplished using a rod which is connected by a wire to the metal housings of the electrical equipment and the shields of the internally installed cables of the laboratory.

The equipment is placed in a UAZ-452 rough terrain motor vehicle. To provide for normal operation under any weather conditions, the body of the motor vehicle is heat insulated with a layer of expanded plastic and layered plastic, and the floor is insulated with linoleum.

The body is equipped with special compartments in which the measurement instruments are placed for transport and storage.

The compartments are made in welded construction housings, made of angle iron. Each housing has a folding lid with a sealing liner of porous rubber, which reliably secures the instruments by means of fastening locks, protecting them from jolts when the motor vehicle is underway.

The internal laboratory installation is executed with concealed wiring. The lines and junction lines are run using shielded conductors.

## CHAPTER 4: MULTIPLEX EQUIPMENT

### 4.1. Audio Frequency Termination Complexes and the Automatic Through Working of High Frequency Telephone Channels

High frequency telephone channels in a rural communications network can be used simultaneously as junction lines on several network sections. To observe the norms for the attenuation distribution, the through call connections should be made in the rural network so that the residual attenuation of the composite HF channel remains approximately 7.0 dB (0.8 Nep). It is necessary for this to provide for matching of the levels of HF telephone channels at the switching points.

Through working of HF telephone channels is realized automatically at central and junction rural ATS's [Automatic Telephone Exchanges]. Two methods of HF channel through call working are distinguished: Two-wire and four-wire. Ten step ATS's are designed for the capability of organizing automatic two-wire through working, while crossbar ATS's, for the capability of organizing automatic four-wire through working (as well as for two-wire through working).

In accordance with the conditions for the organization of communications on a rural network, the audio frequency termination circuits for HF telephone channels should provide the following:

- Automatically making the terminal connections;
- Automatic two-wire through working;
- Automatic four-wire through working;
- Making connections between manually operated telephone exchanges.

The V-2, V-2-2, V-3-3s, VO-3-4, KNK-6S, KNK-6SM, KNK-6T and KNK-12 multiplex equipment contain audio frequency termination complexes which assure the operation of the channel in any of the modes indicated above. The multiplex equipment listed here is the same as regards its functional purpose and operational principle, despite a number of differences in the electrical circuitry, equipment composition, semi-finished products, structural finishing and equipment complement.

The circuit of a channel with automatic terminal connection is shown in Figure 4.1 (using the example of the V-2 equipment). The signal from the telephone set of the speaking subscriber is fed through the differential transformer, DTr, the matching transformer, Tr, the amplitude limiter using diodes D<sub>1</sub> and D<sub>2</sub>, 2.7 dB (0.3 Nep) and 7 dB (0.8 Nep) attenuator pads, and the VKh [input] break jacks to the input of the transmitting part of the multiplex equipment. Following signal modulation and amplification, it is transmitted via the line in the HF range. The signal transmitted via the line, after demodulation and amplification, passes through the Vykh [output] break jacks, the 7 dB (0.8 Nep) and 0.9 dB (0.1 Nep) attenuator pads and a differential transformer, DTr,

to the set of the listening subscriber. The transmission of the telephone signals is realized in an analogous manner in the opposite direction.

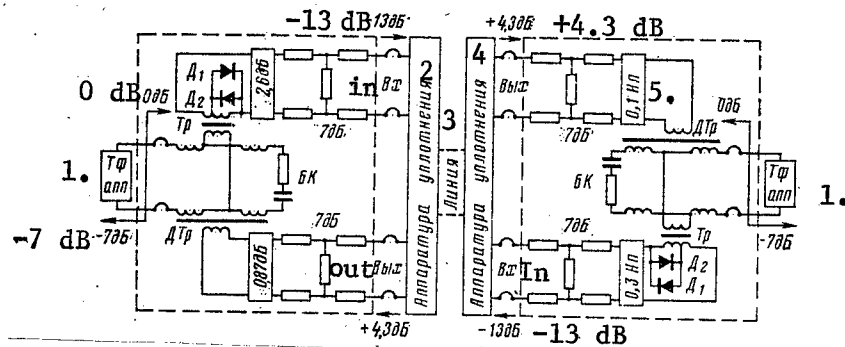

Figure 4.1. Schematic of a channel with automatic terminal connection.

Key: 1. Telephone set; 2. Multiplex equipment; 3. Line; 4. Multiplex equipment; 5. 0.1 Nep.

The attenuation of the transmit and receive routes, including the attenuation of the differential transformer, taking into account losses of 3.4 dB (about 0.4 Nep), is 13.0 and 11.3 dB (1.5 and 1.3 Nep) respectively. When feeding a signal at a zero measurement level into the two wire input of a channel, the level at the input of the transmit channel of the multiplex equipment at the break jacks, Vkh, amounts to -13.0 dB (-1.5 Nep). The measurement level at the output of the receive channel of the multiplex equipment at the break jacks, Vyk, is equal to +4.3 dB (+0.5 Nep). In this case, the receive level at the two wire channel output is -7.0 dB (-0.8 Nep). The diagram of the levels indicated here provides for a residual channel attenuation of 7 dB (0.8 Nep) in the two transmission directions.

A circuit for automatic two-wire through working for a ten step ATS is shown in Figure 4.2 (using the V-2 equipment as an example). For the case of through working of two HF channels for the signal from the ATS, the two 7 dB (0.8 Nep) attenuator pads are switched out of the transmit and receive channels of the outgoing channel. For example, when making a connection from right to left (the calling subscriber is on the right), the attenuator pads of the right channel are switched out. Switching out the attenuator pads provides for an attenuation of the through working exchange close to zero.

A circuit composed of two transistors,  $T_1$  and  $T_2$ , and a through working relay, V, serves for switching out the attenuator pads. For the case of local call through working, a negative voltage is fed from the ATS circuit to the base of transistor  $T_1$  of the outgoing channel, and the transistor turns on, relay V actuates, and switches out the attenuator pads with its contacts. For the case of long distance through call working on a rural network, a negative voltage is fed from the ATS circuit to the base of transistor  $T_2$  in a similar fashion.

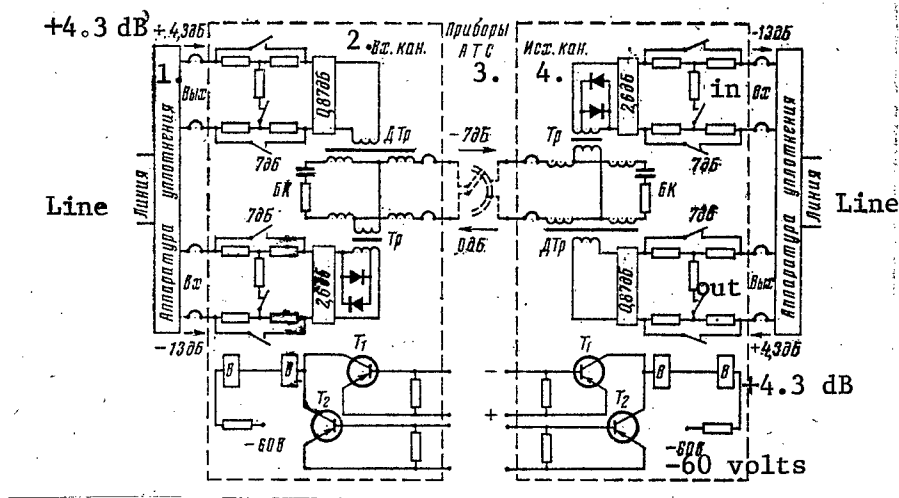

Figure 4.2. Schematic for automatic two-wire through working.

Key: 1. Multiplex equipment; 2. Channel input; 3. Automatic telephone exchange equipment; 4. Channel output.

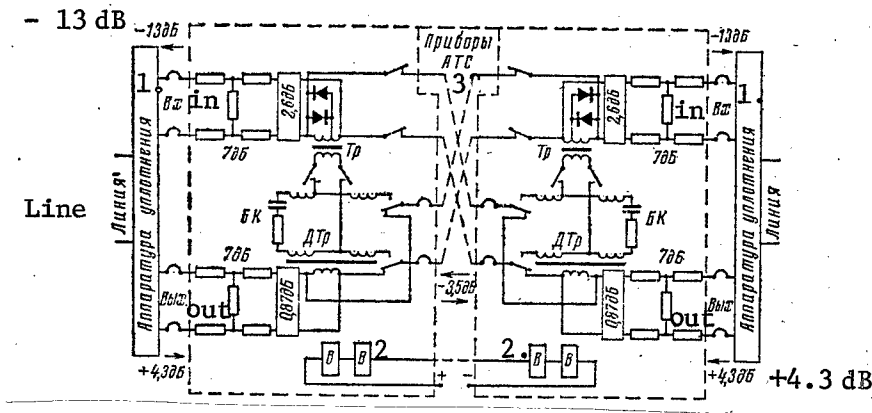

Figure 4.3. Schematic for automatic four-wire through working.

Key: 1. Multiplex equipment; 2. Relays V; 3. Automatic telephone exchange equipment.

For the case of terminal connection, as well as for through call working of the HF channel to a connecting channel organized on a physical circuit, the transistors are cut off and the attenuator pads remain switched in the circuit.

A circuit for automatic four-wire through working at a crossbar ATS is shown in Figure 4.3 (using the V-2 equipment as an example). In this case, the differential transformers, DTr, are switched out of the circuits of the HF

termination complexes participating in the through call working of the channels, and two two-wire transmission channels are formed. Because of this switching over, the through call working of the HF channels is assured without an increase in the attenuation. The measurement level at the switching points is equal to -3.4 dB (-0.4 Nep).

Relays V are included in the HF termination equipment complex, and actuate on a signal from the RSL [connector relay unit].

Three types of audio frequency termination complexes (KNO's) are provided in the V-2 equipment:

- For terminal operation with the capability of automatically switching over to the two-wire through working mode (type I KNO);
- For terminal operation with the capability of automatically switching over to the four-wire through working mode (type II KNO);
- For terminal mode operation between manual exchanges with transmission and reception of the magneto call-up ring via two wires, as well as with negative polarity DC call-up ring receive from the switchboard via one wire (type III KNO); this type of KNO can also be used for making terminal connections between ATS's.

The type of KNO is specified in the order; if the type is not specified in the order, then a type I KNO is installed in the equipment. On site modification of KNO circuits is permitted as an exception.

The KNO complex consists of a printed circuit board, as well as a relay and equalizing capacitors, installed outside the board. The board is designed for the installation of all circuit elements which are used in all three KNO types, but in each case, only those components which are essential to the circuitry of a given type are mounted on the board. When making a modification, the superfluous elements and jumpers are unsoldered, while the missing components and jumpers are soldered into the circuit board. One of the conductor bundles coming up to the board is also changed. The components (resistors, diodes and transistors) necessary for the retrofitting are appended in the ZIP [expansion unknown].

In the V-2-2 equipment, the audio frequency termination complexes provide the same switching capabilities as in the V-2 equipment, but are made structurally in the form of two mutually interchangeable plug-in blocks. One of the KNO blocks of types I - II is intended for automatically making terminal connections with the capability of organizing automatic two-wire or four-wire through working. Changing over from a two-wire circuit to a four-wire through working one, and vice-versa, is accomplished by means of resoldering, where all the components necessary for this, including the relay (type RES-22), are installed on the block circuit board. The second KNO-III block is intended for making terminal connections between manually serviced exchanges and between ATS's. The type of block is specified in the equipment order.

Three types of audio frequency termination plug-in blocks are provided in the V-3-3S equipment:

- The DS block, for terminal mode operation for automatic and manual communications;
- The DS-2T block, for terminal mode operation with the capability of automatically switching over to two-wire through working;
- The DS-4T block, for terminal mode operation with the capability of automatically switching over to four-wire through working.

The type of DS block is specified in the equipment order.

A provision is made in the VO-3-4 equipment, just as in the case of the V-3-3s equipment, for three types of plug-in audio frequency termination blocks:

- The variant I differential system, for terminal mode operation with automatic and manual communications;
- The variant II differential system, for terminal mode operation with the capability of automatic switchover to the two-wire through working mode;
- The variant III differential system, for terminal mode operation with the capability of automatic switchover to the four-wire wire through working mode.

The requisite variant of the differential system is stipulated in the equipment order.

The KNK-6S equipment, which was supplied prior to 1966, was equipped with a type VIJ [Latin letters] audio frequency termination block, intended for terminal mode operation of the channels with automatic and manual communications. Subsequent variants of the equipment, the KNK-6SM and KNK-6T types, were put together as a function of the order for the audio frequency termination blocks of the VIJ or VAJ [Latin letters] types. In addition to automatically making terminal connections, a type VAJ block provides for two-wire or four-wire automatic through working of the channels, where the changeover from a two-wire to a four wire circuit is realized by means of resoldering on the terminal strip of the block. In the case where VIJ blocks in the KNK-6S equipment are replaced by VAJ blocks, it is necessary to tailor the resoldering of the rack equipment to each individual case.

Two types of differential systems are used in the KNK-12 equipment. One differential system is intended for the terminal connection which can be made both automatically and manually. The other differential system serves for making automatic terminal and through call connections, where the changeover from two-wire to four-wire through working, and vice-versa, is accomplished by means of resoldering.

The basic electrical characteristics of the audio frequency termination complexes for all of the multiplex equipment types treated here are approximately the same. The amplitude response characteristics of the limiters incorporated

into the equipment complement<sup>1</sup> are flat within 0.2 - 0.43 dB (0.03 - 0.05 Nep) when the input signal level increases 3.4 dB (0.4 Nep) above the measurement level, and deviates from a linear response by no more than 2.2 - 2.7 dB (0.25 - 0.3 Nep), when the input level increases by 8.5 dB (1 Nep). The balancing networks consist of a 600 ohm resistor and two 0.5 and 1.0  $\mu$ fd capacitors, which permit shifting the balancing capacity within limits of 0.33 - 1.5  $\mu$ fd. Provisions are made in all circuits with two-wire through working for outputs to connect external balancing networks.

The audio frequency termination complexes assure equality of the channel input impedance on the 600 ohm two-wire input side with a return loss in a frequency range of 300 - 3,400 Hz not exceeding 10% (when the isolating capacitor protecting against induced current overloads is cut out). The input and output impedances of the channels at the -13 dB (-1.5 Nep) and +4.3 dB (0.5 Nep) level points are 600 ohms with return loss factors at frequencies of 300 - 3,400 Hz not exceeding the quantities indicated in Table 4.1.

TABLE 4.1. Return Loss Factor

Equipment	V-2, V-2-2	V-3-3S	VO-3-4	KNK-6S	KNK-6SM	KNK-12
Return Loss Factor, %	25	15	10 (Transmit) 15 (Receive)	20-30	25	20

Any type of audio frequency termination complexes can be installed at terminal ATS's (OS's [terminal exchanges]). Installed at through working ten-step and crossbar ATS's (junction centers, subexchanges, central exchanges) are complexes intended for not only terminal connections, but also for the capability of automatic changeover to the corresponding two-wire or four-wire through working mode.

When multiplexing lines between an ATS and a manually serviced exchange, any type of audio frequency termination complexes can be employed, and where necessary, with the corresponding automatic through call working to the ATS. Complexes intended for a terminal operational mode with manual servicing are used for communications between switchboards.

#### 4.2. The Line Spectra of Open Wire Line Multiplex Equipment up to 30 KHz

The line spectra of the V-3-3, V-3-3S, V-2, V-2-2, K-3<sup>2</sup>, UDK-1 and UDK-2 equipment for multiplexing rural steel circuits are shown in Figure 4.4. The line spectra of the VO-3-4 equipment, which differs slightly from the V-3-3S spectra are shown in Figure 4.12. The line spectrum of the V-2-2 equipment coincides with the V-2 spectrum.

<sup>1</sup> In the V-3-3S equipment, the amplitude limiter is mounted outside the audio frequency termination complex.

<sup>2</sup> The K-3 equipment has not found wide application on rural networks.

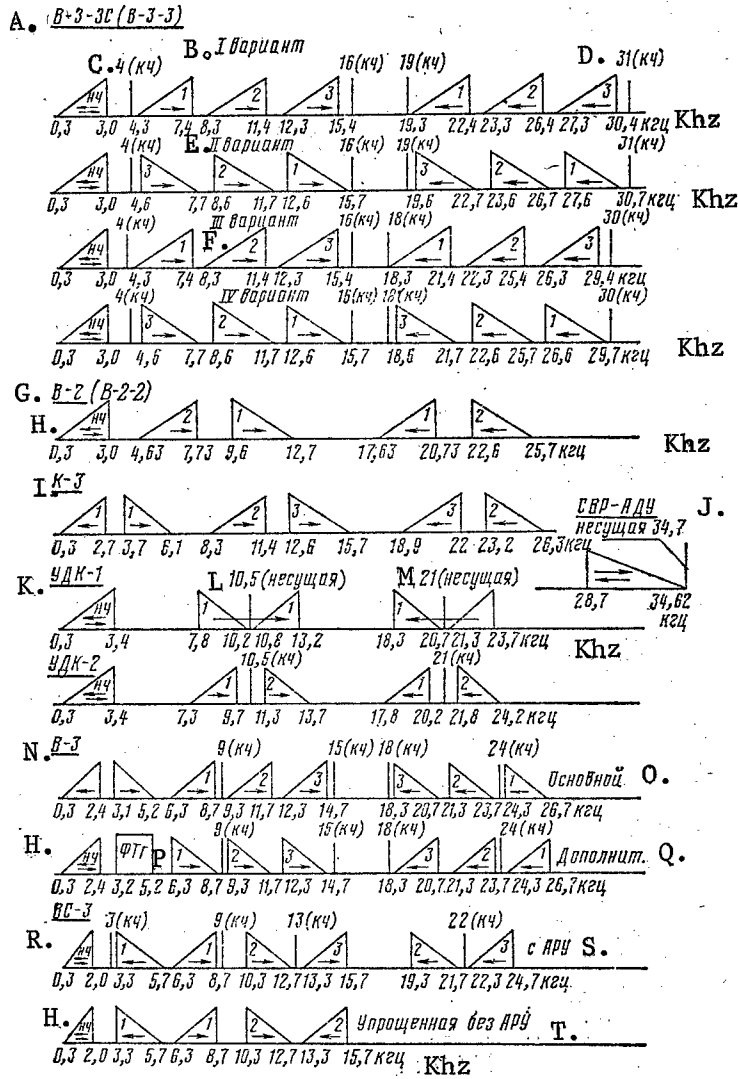

Figure 4.4. The line spectra of open wire line multiplex equipment up to 30 KHz.

Key: A. V-3-3S (V-3-3); B. Variant I; C. 0.3 to 3.0 KHz, audio; D. 31 [KHz] (channel frequency); E. Variant II; F. Variant III; G. V-2 (V-2-2); H. Audio frequency, 0.3 - 3.0 [KHz]; I. K-3; J. SVR-ADU, 34.7 KHz carrier; K. UDK-1; L. 10.5 (carrier); M. 21 (carrier); N. V-3; O. Main; P. FTg [facsimile]; Q. Additional; R. VS-3; S. With ARU [automatic gain control]; T. Simplified, without ARU.

Parts of rural circuits are strung on long distance communications line poles. For this reason, the mutual coupling between the rural and long distance multiplex systems has to be taken into account. The line spectra of V-3 three



channel long distance systems for multiplexing circuits of nonferrous metals, and the VS-3 type for multiplexing steel circuits are shown in Figure 4.4. The line spectra of the three channel V-3-3 system, intended for multiplexing both nonferrous and steel circuits for long distance communications coincide with the spectra of the V-3-3S rural system.

To avoid opposing telephony in all systems, working in a frequency range up to 30 KHz, the lower group of channels is always transmitted (from exchange A to exchange B, the A-B direction) from north to south and from east to west, while the upper group (from exchange B to exchange A, the B-A direction) from south to north and from east to west. The sole exception is the part of the spectrum of the first channel of the VS-3 equipment close to 5 KHz. This proves to be permissible because of the adequately high crosstalk attenuation at the near end and the low transmission attenuation at relatively low frequencies. As far as the spectrum of the second channel of the simplified VS-3 equipment is concerned, this channel is employed only in the absence of parallel multiplexed circuits strung on the same support poles.

The correct choice of the transmission directions makes it possible to consider only the influence at the far end, the crosstalk between systems operating on parallel circuits with overlapping spectra in the same direction. The coupling at the far end is brought down to the existing norms by means of transposing the circuits in accordance with the "Instruktsii po skreshchivaniyu telefonnykh tsepey vozdushnykh linii svyazi" ["Instructions on the Transposition of Open Wire Communications Line Telephone Circuits"], Moscow, Svyaz' Publishers, 1968.

In a number of cases, a substantial increase in the crosstalk attenuation between steel circuits can be achieved by means of an even simpler measure: Concentrated balancing by means of switching equalizing RC networks in at the ends of the amplified sections.

Audible transfers, arising between multiplexed systems operating with the same line spectrum, represent the greatest danger. A line spectrum variant is provided in each of the UDK-1, UDK-2, K-3, V 2 and V-2-2 units.

In the V-3-3S and VO-3-4 equipment, to prevent audible crossovers, arising when multiplexing parallel circuits, in inaudible ones, four variants each of the line spectra are provided. In the V-3-3S equipment, the I and III variants differ from the II and IV variants by the frequency inversions, while the I and II variants additionally differ from the III and IV variants by the frequency shift in the upper group. The A and D variants of the line spectra of the VO-3-4 equipment coincide with the I and IV variants respectively of the V-3-3S equipment spectrum, while the B and C variants of the VO-3-4 equipment differ from the II and III variants of the V-3-3S by the frequency inversion in the lower group of channels (Figures 4.4 and 4.12).

The spectrum inversion of the frequencies adds to the isolation against crosstalk noise by 8.5 dB (1.0 Nep), while the frequency shift, without inversion,

adds 6.0 dB (0.7 Nep). Additionally, a provision is made in the V-3-3S and VO-3-4 equipment for the option of using companders which suppress noise by 13 dB (1.5 Nep).

Rural steel circuits are also multiplexed with HF broadcasting systems. The spectrum of one of these systems of the SVR-ADU type, intended for feeding broadcast programs to rural radio repeater junctions and for the remote control of them from the regional center is shown in Figure 4.4. Included in the SVR-ADU equipment complement are the transmitting, branching, amplifying and receiving stations. Used in the equipment is the method of transmitting the carrier current and one sideband (the lower one) on the line. The transmit level on the line with respect to the carrier at the transmit and branching stations is +30.4 dB (3.5 Nep), and at the amplifier station, is +26.0 dB (3 Nep). The sideband is transmitted into the line at a level of 13.9 dB (1.6 Nep) below the 34.7 KHz carrier level. The maximum attenuation of the amplified sections coming after the transmitting and branching stations is 43.4 dB (5 Nep) at a frequency of 34.7 KHz, and for the sections coming after the amplifier station, 39.0 dB (4.5 Nep). The maximum length of the amplified sections intended for operation under worst case conditions into lines of "20 mm rime ice" is given in Table 4.2. The maximum number of amplified sections is four.

For the case of SVR-ADU equipment operation on parallel circuits with telephone systems occupying a frequency range of from 24 to 30 KHz, incorporated into the channel of the transmitting station is a D-6 filter which limits the bandpass of the broadcast channel to 6 KHz, while at the remaining exchanges, the LF-1 (D-12, K-20) line filter plug is replaced by the LF-11 (D-12, K-28) plug.

TABLE 4.2. The Maximum Lengths of the Amplified Sections in Km for SVR-ADU Equipment

1. Расстояние между проводами, см	2. Затухание участка 39,0 дБ (4,5 Нп) при диаметре проводов		3. Затухание участка 43,4 дБ (5 Нп) при диаметре проводов	
	3 мм	4 мм	3 мм	4 мм
20	18,5	22,2	20,6	24,8
40	21,0	25,3	23,3	28,1
60	22,5	27,1	25,0	31,1

Key: 1. Distance between the conductors, cm; 2. 39.0 dB (4.5 Nep) section attenuation for a conductor of:; 3. 43.4 dB (5 Nep) section attenuation for a conductor diameter of:.

For multiplexed telephone systems, the choice of the transmission directions is made according to the points of the compass. The broadcast network though, is built out from the regional center on a radial principle. For this reason, in 50% of the cases, opposing transmission will occur between the high frequency telephony and broadcast systems.

The line spectra of the V-3-3S and VO-3-4 equipment in a frequency range of 28.7 - 30 (31) KHz overlap with the SVR-ADU spectrum. For this reason, even on transposed circuits, these systems cannot work into each other on parallel lines over long amplified sections. The opposing operation of these systems is possible only over shortened sections.

Cover filters which protect the telephone channels and the broadcast channel against crosstalk interference are provided in the UDK-2 and V-2 equipment. When the line filters (LF-I or LF-II) are replaced in the SVR-ADU equipment by specially designed filters, this equipment can operate over one circuit with the UDK-2 equipment, with the exception of the case of opposing transmission. The SVR-ADU equipment can operate with UDK-2, V-2 and V-2-2 equipment on parallel transposed circuits, including the case of opposing transmission.

#### 4.3. The Signal Channels of Multiplex Equipment

A characteristic feature of multiplex equipment intended for operation on a rural automated network is the transmission of control and interaction signals via a signal channel which is separated out. The basic data on signal channels for certain types of rural communications equipment are given in Table 4.3.

TABLE 4.3. Signal Channel Data

Аппаратура Equipment	1. Вынесенный сигнальный канал	
	Working рабочая частота, Гц Frequency Hz	уровень передачи относительно изме- рительного, дБ (Нп) 2.
УДК-2 UDK-2	3000	0
В-2, В-2-2 V-2, V-2-2	4000	-6,0 (-0,7)
В-3-3С V-3-3S	3825	-10,4 (-1,2)
ВО-3-4 VO-3-4	3825	-6,0 (-0,7)
3. КНК-6С, КНК-6СМ	3850	0
КНК-6Т КНК-6Т	3850	-6,0 (-0,7)
КНК-12 КНК-12	3825	-20,0 (-2,3)

Key: 1. Extracted signal channel; 2. Transmit level with respect to the measurement [level], dB (Nep); 3, КНК-6S, КНК-6SM.

The main features of the operational conditions and certain characteristics of signal channels which are common to all multiplex systems used on a rural network are:

1. Each telephone channel is equipped with its own isolated signal channel, which serves for the transmission of control and interaction signals with automatic call completion, and for transmitting the ring-up in the case of manual servicing. No provision is made for signal transmission via the signal channel before the telephone channel is occupied, and during a conversation (with the exception of КНК-12 equipment).

2. To exclude the possibility of self-excitation, the telephone channel is either loaded into an equivalent resistance or short circuited by means of the RSL [connector relay] from the moment it is engaged until the called subscriber answers.

3. To preclude false actuations, the signal channel is protected by filters against noise from the telephone channels. A check of the isolation is made by feeding measurement signals at a level of +4.3 dB (0.5 Nep) above the nominal into the telephone channel input. When the frequency of the signal is varied within limits of 300 - 5,000 Hz, the signal channel receiver should not actuate.

The noise immunity of the signal channel likewise depends on the nonlinear distortion factor and the load level on the telephone channel. To protect the signal channel against nonlinear interference, when the limiter is switched out in the telephone channel, a provision is made for an excess in the frequency response. Additionally, an amplitude limiter is inserted at the telephone channel input for the purpose of decreasing its load. A check of the protection of the signal channel against nonlinear noise is accomplished by means of sequentially feeding signals at frequencies of  $(1/2)f_c$  and  $(1/3)f_c$  into the channel input with the limiter switched in, where  $f_c$  is the working frequency of the signal channel; at a level of the test signals which exceeds the measurement level by 10.4 - 13.0 dB (1.2 - 1.5 Nep), the receiver should not actuate.

4. The operation of the signal channel should not cause noticeable interference in adjacent telephone channels.

5. The distortion in the 20 and 40 msec wide pulses transmitted via the signal channel should not exceed  $\pm 6$  msec. This should be observed during a change in the receive level, the ambient temperature and when interference is present on the line.

6. The control of the operation of the signal channel from the RSL, and the relaying of transmitted pulses to the RSL is realized via one wire, using a positive polarity by means of a closing contact.

#### 4.4. The UDK-1 and UDK-2 Equipment

The UDK-1 equipment is built to transmit a carrier and two sidebands into a line, and provides for the organization of one HF telephone channel on a steel circuit, in addition to the existing audio channel. A 10.5 KHz carrier and two sidebands in a range of 7.8 - 13.2 KHz are transmitted on a line in the A-B direction, and in the B-A direction a 21 KHz carrier and two sidebands are transmitted in a range of 18.3 - 23.7 KHz (Figure 4.4.).

The transmit level on the line is 6.0 dB (0.7 Nep) for the carrier, while the modulation coefficient corresponding to the measurement level is 60 - 70%.

The transmission of the call-up and dial signals is accomplished by means of retuning the carrier frequency from 10.5 to 7.4 KHz in the lower transmission and from 21 to 17.9 KHz in the upper direction.

The UDK-2 equipment is designed for multiplexing a steel circuit with two HF telephone channels. Included in the equipment complement are terminal and intermediate stations. To compensate for the change in the line attenuation, a flat ARU [automatic gain control] response is provided in the intermediate and terminal equipment.

The equipment operates with the transmission of one sideband into the line. The shift of the channel spectra from the HF range to the line spectrum is accomplished by means of a single individual conversion of the frequency by means of 7, 14, 17.5 and 24.5 KHz carriers, which are derived from a 21 KHz master oscillator, located at station B. In the A-B direction, the two channel group is transmitted in a range of 7.3 - 13.7 KHz, and in the B-A direction, in a range of 17.8 - 24.2 KHz (Figure 4.4). For controlling the ARU devices, a control current at a frequency of 10.5 KHz is transmitted in the A-B direction, while transmitted in the B-A direction is a 21 KHz control signal which is used simultaneously for synchronizing the carriers of the opposite terminal stations.

The transmission level on the line is 4.3 dB (0.5 Nep) (with respect to power). The 10.5 and 21 KHz monitor signals are transmitted at the same level on the line.

When the attenuation of the steel circuit deviates by -6 to +3.4 dB (-0.7 to +0.4 Nep) from the average value, which corresponds to a change in the conditions from "12 mm rime ice" to "summer - damp" and from "summer - damp" to "winter - dry", the ARU maintains the output level of the monitor signal constant within -0.9 to 0.4 dB (-0.1 to +0.05 Nep).

The call-up and dial signals are transmitted via the extracted signal channel at a frequency of 3,000 Hz, working at the measurement level. The distortion of the pulses transmitted via the signal channel do not exceed  $\pm 6$  msec.

To increase the range of the UDK-1 and UDK-2 equipment, the PS-UDK-1 and PS-UDK-2 intermediate stations respectively, are employed. Additionally, a universal PS-2M-UDK station has been produced which can be used as an intermediate station, both for UDK-2 equipment and for the UDK-1. The basic data for the UDK-1 and UDK-2 equipment are given in Table 4.4.

The HF terminations circuitry of the UDK-1 and UDK-2 equipment is designed for operation of the HF channels in a terminal mode with a residual attenuation of 7 dB (0.8 Nep) between automatic and manual telephone exchanges, as well as for organizing permanent two-wire and four-wire through working (using resoldering). Additionally, a provision is made in the UDK-2 equipment for the capability of organizing automatic two-wire through working between UDK-2 equipment channels without increasing the attenuation.

The power supply for the equipment is from DC exchange sources at -24 or -60 volts<sup>1</sup>. The current consumption for a UDK-1 terminal station is 25 mA, and for

<sup>1</sup> A DC regulator is provided in the UDK-2 equipment which is designed for an input voltage change of -20% to +30%.

TABLE 4.4. Basic Data on the UDK-1 and UDK-2 Equipment

Characteristic	Unit of Measurement	Equipment	
		UDK-1	UDK-2
Maximum attenuation of an amplified section (for "summer-damp") conditions which can be compensated	dB	30.4 (3.5) at a frequency of 21KHz	34.7 (4) at a frequency of 24.2 KHz
Maximum length of an amplified section via a steel circuit with conductor diameters of 3 and 4 mm	Km	25 and 30	25 and 30
Maximum communications range when using:			
One intermediate station	Km	50 - 60	50 - 60
Two intermediate stations	Km	-	Up to 75
Input impedance from the line side	Ohms	1,000	1,000 <sup>1</sup>
Return loss factor	%	20	20
Frequency passband which can be effectively transmitted via the HF channels	Hz	300 - 2,700	300 - 2,700
Nonlinear distortion factor, no greater than	%	5	3
Amplitude response when the level at the channel input increases 4.3 dB (0.5 Nep) above the measurement level (with the limiter switched in)	-	-	Flat within 0.9 dB (0.1 Nep)
Inherent noise voltage of the terminal equipment at the channel output at the point with a level of -7 dB (-0.8 Nep), no greater than	Millivolts Psophometric	-	0.2
Isolation against audible cross-talk between channels, no less than	dB (Nep)	-	56.5 (6.5)

<sup>1</sup> A provision is made for resoldering the inputs of the terminal and intermediate stations for an impedance of 150 ohms.

a UDK-2 terminal station, 230 ± 15 mA. A DC regulator is provided in the UDK-2, which is designed for an input voltage change of from -20 to +30%. The UDK-2 equipment can be powered from the AC mains through the VDK-2 rectifier, while the UDK-1 can be powered through the VDK-1 rectifier.

The intermediate station is powered either remotely with the terminal station from a -60 volt source, or from local DC (-24 or -60 volt) or AC (through the VDK-1 or VDK-2 rectifiers) sources. The DC consumption is 90 - 100 mA.

A meter is provided in the terminal and intermediate equipment which permits monitoring the power supply voltage and the transmit and receive levels.

Terminal and intermediate stations are intended for operation in heated rooms and are housed in a rack or secured to a wall with a bracket.

Plug-in blocks with bulk mounting comprise the structural basis for the equipment. An external view of the UDK-2 terminal station is shown in Figure 4.5. The main structural data are given in Table 4.5.

TABLE 4.5. Structural Data for the UDK-1 and UDK-2 Equipment

Equipment	Number of Plug-in Blocks	Dimensions, mm	Weight, Kg
UDK-1 terminal station	7	380 x 80 x 180	About 10
UDK-2 terminal station	16	460 x 190 x 225	About 25
UDK-2 intermediate station	8 <sup>1</sup>	460 x 95 x 225	About 12

<sup>1</sup> Without the power supply and protective unit (the ZPU) with dimensions of 286 x 125 x 115 mm.

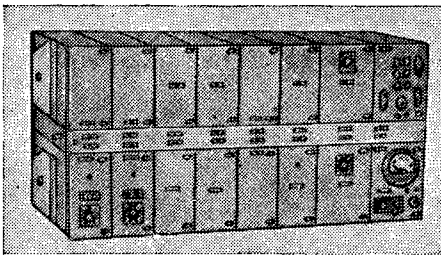

Figure 4.5. General view of the UDK-2 terminal equipment.

on central exchange to junction center and junction center to terminal exchange sections.

The audio channel in the UDK-1 and UDK-2 equipment is limited at frequencies of 4.9 and 5.4 - 5.5 KHz respectively. For the case of one section, i.e. in the absence of intermediate amplifiers, the audio channel can be used as a junction channel between telephone exchanges. With two to three amplified sections, the audio channel can be used as a service channel. If the intermediate station is located at a junction telephone center, a US, the audio channel can be used in sections for organizing junction channels

#### 4.5. The V-2 and V-2-2 Equipment

The V-2 equipment (Figure 4.6) is intended for multiplexing short steel circuits between rural telephone exchanges with two HF channels. In this case, the existing audio channel is preserved.

The equipment does not have any intermediate stations. Depending on the diameter of the steel circuit conductors and the spacings between them, the equipment assures the communications range shown in Table 4.6.

The equipment is designed around the group principle with the transmission of one sideband into the line. The individual conversion of the audio

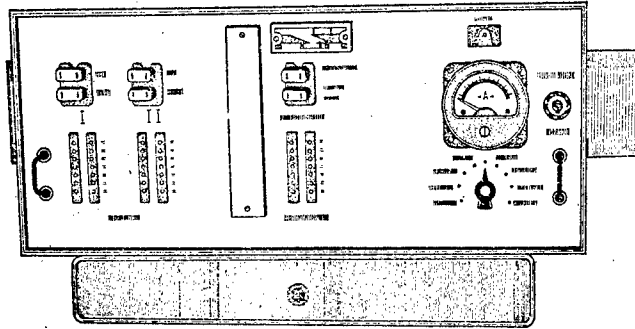

Figure 4.6. General view of the V-2 equipment.

TABLE 4.6. The Communications Range in Km when Multiplexing Steel Circuits with V-2 Equipment

1. При расстояниях между проводами, см	2. При диаметре проводов 3 мм		3. При диаметре проводов 4 мм	
	макс	мин	макс	мин
20	22	7,5	27	9,0
30	23,7	7,9	28,5	9,5
60	26	8,5	32	11

Key: 1. For spacings between the conductors of, cm;  
 2. For a conductor diameter of 3 mm;  
 3. For a conductor diameter of 4 mm.

For transmission in the opposite A-B direction, the two channel group is shifted by means of a 30.33 KHz carrier to a range of 4.63 - 12.7 KHz (Figure 4.4.). All the carrier frequencies at each station are derived from one master crystal oscillator at 17.33 KHz.

The transmission and reception of the ring and dial signals is accomplished on the isolated signal channel at 4,000 Hz at a level of 6.0 dB (0.7 Nep) below the measurement level. The distortion of the pulses transmitted via the signal channel does not exceed  $\pm 6$  msec.

The power supply is from -24 or -60 volt DC sources with voltage fluctuations of from -10 to +20 %. The current consumption for one terminal station is 150 mA, and for the simultaneous operation of two signal channels, 270 mA.

spectrum of the first channel is realized by a 17.33 KHz carrier, while the conversion of the audio spectrum of the second channel is accomplished by means of a 26 KHz carrier. Individual balanced modulators are designed around transistors in a phase difference circuit and for a frequency range offset from the carrier by 300 - 900 Hz; they suppress the unused sideband 26 dB (3 Nep). The suppression of the unused sideband in a wider frequency range is accomplished by group filters. The two channel group which is formed, and which occupies a range of from 17.63 to 25.7 KHz, is transmitted via the line directly in the B-A



TABLE 4.7. Basic Characteristics of the V-2 Equipment

Characteristic	Unit of Measurement	Magnitudes
Maximum gain at 25.7 KHz:		
Under conditions of "summer-damp"	dB (Nep)	34.7 (4.0)
Under conditions of "12 mm ice coating"	dB (Nep)	42.6 (4.9)
Transmit level into the line (with respect to power)	dB (Nep)	+4.3 (+0.5)
Input impedance from the line side	ohms	800 or 180
Return loss factor, no greater than	%	20
Peak factor of the group channel, no less than	dB (Nep)	10.4 (1.2)
Passband of the HF telephone channels	Hz	300 - 3,400
Amplitude response characteristic of the HF telephone channels	Flat within 0.9 dB (0.1 Nep) when the input level increases 7 dB (0.8 Nep) above the measurement level.	
Nonlinear distortion factor, no greater than:		
Total	%	3
Third harmonic distortion	%	1
Internal noise voltage at the channel output at the point with a level of +4.3 dB (+0.5 Nep), no greater than	Millivolts psophometric	1
Isolation from audible crossovers between the channels, no less than	dB (Nep)	60.8 (7.0)

A meter is provided in the equipment which permits monitoring the power supply voltage, the transmission level, the residual attenuation of the channels, and also permits carrying out a rough alignment of the equipment on the line by means of setting the residual attenuation of the channels at a frequency of 800 Hz with an accuracy of  $\pm 1.3$  dB ( $\pm 0.5$  Nep).

The equipment is designed for operation under fixed station conditions in heated rooms at a temperature of from +10 to +40° C, and a humidity of up to 80%.

The equipment is structurally packaged in the form of an instrument which consists of an HF block with dimensions of 412 x 170 x 245 mm and an audio block fastened to it having dimensions of 336 x 48 x 245 mm, made in the form of a support (Figure 4.6). All of the HF channel equipment is placed in the HF block. Located on the front panel of the HF block are the meter and the adjusting devices, the access to which is necessary when aligning and operating the equipment.

The audio block contains KNO [low frequency termination complex] circuits, relays and instrumentation jacks for all three channels. Both blocks are connected at the rear by a cable with 30 contact connectors. The HF block is a plug-in design and can be removed from the housing. A 1.5 m long cable terminating in a 30 contact connector is provided for connecting it into the exchange circuitry.

The equipment can be set up on a desk, wall (shelf), as well as in a bay by means of the angle brackets included in the equipment complement. The weight of one terminal station is 15 Kg.

Produced for the V-2 equipment is the EK-V-2 operational complex, the complement of which includes a number of boards and blocks, as well as spare parts (coils, capacitors, crystals, transistors, diodes, etc.).

TABLE 4.8. The Lengths of Amplified Sections and the Communications Range When Multiplexing Steel Circuits with V-2-2 Equipment

1. Цепь		Колич. усилит. участков	Длины усилительных участков, км	Дальность связи, км
d, мм	a, см			
3	20	1	23,8	23,8
	30		25,0	25,0
	60		27,4	27,4
	20	2	21,8	43,6
	30		22,9	45,8
	60		25,0	50
	20	3	20,4	61,2
	30		21,7	65,1
	60		23,8	71,4
4	20	1	28,6	28,6
	30		30,0	30,0
	60		33,4	33,4
	20	2	26,1	52,2
	30		27,4	54,8
	60		30,5	61
	20	3	24,8	74,4
	30		26,0	78
	60		29,0	87

Key: 1. Circuit; 2. Number of amplified sections; 3. Lengths of the amplified sections, Km; 4. Communications range, Km.

The V-2-2 equipment, just as the V-2 unit, is intended for multiplexing steel circuits with two HF telephone channels, but has a flat ARU and is designed for the capability of increasing the operational range by using one or two unattended intermediate stations. The characteristics of the equipment are given in Table 4.7. The lengths of the amplified sections and the communications range are given in Table 4.8.

For the control of the ARU devices via the line in the A-B and B-A directions, control signals at 8.67 and 21.67 KHz respectively are transmitted at levels 6.0 dB (0.7 Nep) below the measurement level. In the B-A direction, automatic gain control is realized both at the terminal and the intermediate stations, while in the A-B direction, only at the terminal station. The receivers of the monitor channels for the lower and upper transmission directions are identical and are controlled by the 21.67 KHz control signal. The error in ARU operation does not exceed  $\pm 0.9$  dB ( $\pm 0.1$  Nep) when the conditions on the line change from "winter-dry" to "12 mm ice coating".

The V-2-2 equipment differs from the V-2 equipment in its electrical and structural refinements.

The electrical power supply for the terminal station is a 24 or 60 volt (-10 to +20%) source; the current consumption is 330 mA (when the call-up devices operate, 80 mA). For an intermediate station, the voltage for a "two conductors - ground" circuit from the terminal station is -60 volts (-10%, +20%), and from local sources, 25 or 60 volts (-10 to +20%). The current consumption is 85 mA. The DC resistance of the remote supply circuit for "two conductors - ground" should not exceed 350 ohms.

A meter is provided at the terminal station which permits monitoring the regulated power supply voltages (-18 and -22 volts), the remote supply current and the current through the ARU termistor. Also provided is the capability of checking the proper operation of the terminal station "into itself", including the group equipment. Automatic monitoring of the group channel provides for the operation of alert signaling and blocking of the channels in case the control current is lost.

The terminal station (OV-2-2) consists of 12 plug-in blocks (Figure 4.7a). One of the blocks is an engineering block for connecting the removed blocks into the station circuitry during alignment and repair. Located on the front panels of the blocks are instrumentation sockets, a meter and adjustment controls. The back of the station is closed off by a wall.

The intermediate station (PV-2-2) consists of seven plug-in blocks (including the engineering block), two soldered in line protection blocks, and are made in fashion structurally similar to the terminal station (Figure 4.7b). The majority of the blocks of the terminal and intermediate equipment are modular and interchangeable.

The dimensions of the terminal and intermediate stations are identical and equal to 550 x 214 x 230 mm, while the weights are 20 and 15 Kg respectively.

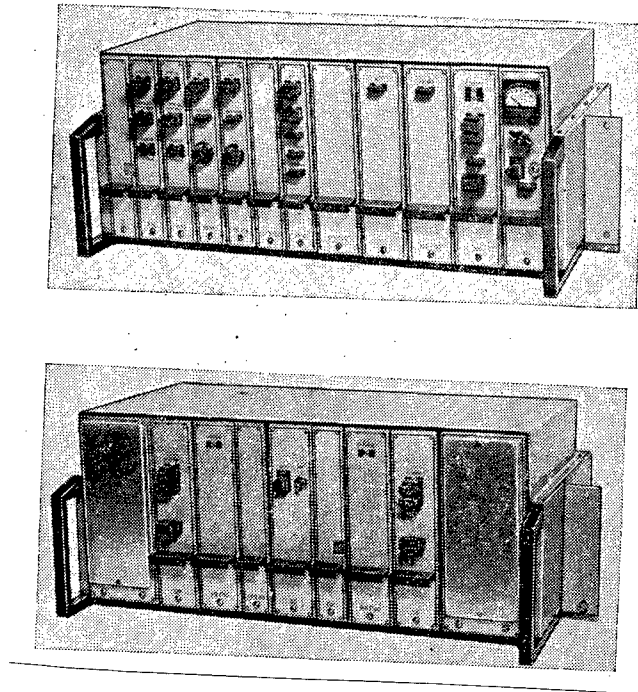

Figure 4.7. General view of the V-2-2 equipment:  
 a) Terminal station; b) Intermediate station.

The terminal and intermediate stations can be set up in a bay, on a wall (shelf) or desk, and are designed for operation in rooms at a temperature of from +10 to +40° C, and a humidity up to 80%.

The audio channel in the V-2 and V-2-2 equipment is limited to 3 KHz. Just as in the UDK equipment, the audio channel on one amplified sections can be used as a junction between telephone exchanges, and as a service channel in the case of two or three amplified sections. When the intermediate station is located at the telephone junction center, the US, it is possible to use the audio channel in sections for organizing junction lines between a central exchange and a junction center, and between a junction center and a terminal exchange.

#### 4.6. The STN-2 and ST-5 Racks

The STN-2 and ST-5 racks are intended for the housing and operational servicing of the V-2, V-2-2, PV-2-2, UDK-2 and PS-UDK-2 low capacity rural telephone communications equipment. Two stations each can be installed in the STN-2 wall type rack, while the floor type ST-5 rack can house up to 5 - 6 stations of any of the types enumerated above.

The racks contain the instruments and devices which are necessary for:

- Making check measurements of the multiplex equipment;
- Remote measurement of the residual telephone channel attenuation;
- Conducting service telephone conversations via the audio and HF channels of the equipment installed in the rack;
- Setting up phantom circuits;
- Establishing protection against dangerous and interfering voltages in accordance with GOST 5238-66;
- Organizing the rack, ordinary and overall exchange signaling.

The STN-2 rack is powered from a 22 - 34 volt exchange battery, and the ST-5 rack, from the AC mains at a voltage of 120/220 volts (+10%, -15%) with the capability of automatically switching over to exchange battery power at 22 - 34 volts or 54 - 72 volts in case the mains voltage drops by 15% or fails altogether. It is possible to set up remote powering of the intermediate stations at a voltage of -60 volts from the V-2-2 and UDK-2 terminal stations installed in the ST-5 rack.

The main equipment complement of the racks is given in Table 4.9.

Additionally installed in the ST-5 rack is a power supply panel, which contains:

- 22 - 36 volt or 54- 72 volt rectifiers for supplying the multiplex equipment stations;
- A  $24 \pm 1$  volt rectifier for supplying the instruments and other components installed in the rack;
- a 47 - 60 volt rectifier for the remote control of the measurements of the residual attenuation of the channels.

Two-wire break jacks are provided in the racks for the audio and HF channels, and for the line circuits, as well as load resistors of 120, 600, 800, 1,000 and 1,400 ohms. Remo

Remote measurements of the residual attenuation are possible in systems without intermediate stations, where these measurements should be carried out from the ST-5 rack. The STN-2 and ST-5 racks have a weight of no more than 40 and 120 Kg respectively, and dimensions of 810 x 650 x 240 and 2,150 x 650 x 240 (without protruding parts). The racks can also be used for mechanically securing the UMS-1, UMS-3 and UMS-5 bridging amplifiers.

#### 4.7. The V-3-3S Equipment

Function: The equipment is intended for multiplexing open wire steel circuits with three HF telephone channels in a spectrum of up to 30 - 31 KHz. The equipment also permits the organization of six HF telephone channels on type

TABLE 4.9. Equipment Complement of the Racks

Equipment	STN-2	ST-5
An 800 Hz signal generator with a zero output level and an output impedance of 600 ohms <sup>1</sup>	1 Unit	1 Unit
Level meter for a frequency range of 0.3 - 3.0 KHz and a measurement range of from -43.4 to +26.0 dB (-5 to +3 Nep), with a 600 ohm and high impedance (greater than 7 KOhms) inputs	-	1 Unit
Intercom and call-up unit	1 Unit	1 Unit
Line transformers	2 Units	6 Units
Phantom transformers	1 Unit	2 Units <sup>2</sup>
Input and protection device for steel circuits, which are multiplexed up to 30 KHz	For 2 circuits	For 6 circuits <sup>3</sup>

<sup>1</sup> Attenuator pads are provided in the racks for reducing the output level to -13 dB (1.5 Nep).

<sup>2</sup> A position is provided in the ST-5 for the installation of a third phantom transformer.

<sup>3</sup> The ST-5 rack is supplied without the input, switching and protection panel, the VKZ. The need for a VKZ panel for six physical circuits is specified when ordering. The VKZ panel is installed at the position set aside for the first station.

VTSP and KSPP single quadded cables when multiplexing with two systems.

The effective passband which can be transmitted is 300 - 3,400 Hz; the equipment is designed for secondary multiplexing with multichannel audio frequency telegraphy and facsimile signals. With secondary multiplexing, one telephone channel can be occupied simultaneously.

To facilitate the operational conditions for parallel circuits strung on the same poles, four variants of the line spectrum (Figure 4.4.) are provided in the equipment.

The terminal stations (OV-3-3S) are equipped with dual frequency, flat-sloped ARU devices [AGC devices] and have a transmission level of +16,5 dB (+1.9 Nep) (with respect to power). The remotely powered, intermediate amplifier stations (NUP V-3-3S) do not contain ARU devices and have a nominal (maximum) transmission level of +4.3 dB (0.5 Nep). The maximum number of unattended amplifier stations between terminal stations is two.

TABLE 4.10. Maximum Lengths of Amplified Sections and the Communications Range When Multiplexing a Steel Circuit,  $d = 4$  mm,  $a = 20$  cm Using V-3-3S Equipment (Channels Without Companders)

Оборудование Equipment	1. Длина, км/затухание, дБ для участка			Общ. длина, км/общ. затухание дБ
	I	II	III	
3. Две оконечные станции без НУП	31,6	—	—	31,6
	46,9			46,9
4. Две оконечные станции с одним НУП	31	19	—	50
	45,8	28,1		73,9
5. Две оконечные станции с двумя НУП	30,5	18,6	16,5	65,6
	45,1	27,4	24,3	96,8

Key: 1. Lengths, Km/attenuation, dB, for a section;; 2. Overall length, Km/total attenuation, dB; 3. Two terminal stations without an NUP [unattended amplifier station]; 4. Two terminal stations with one NUP; 5. Two terminal stations with two NUP's.

Note: The attenuation magnitudes are given for conditions of "25 mm ice coating.

The V-3-3S equipment was designed around the V-3-3 equipment. The majorit of the V-3-3 and V-3-3S equipment blocks are standardized. In contrast to the V-3-3 equipment, in which the transmission of the call-up and dialing signals is realized within the passband of the telephone channel at a frequency of 2,100 Hz, used for this purpose in the V-3-3S equipment is an isolated signal channel operating at 3,825 Hz.

Range: The equipment provides for the organization of communications over one, two, or three amplified sections. The lengths of the amplified sections and the range for various cases where the equipment is used are given in Tables 4.10 - 4.13<sup>1</sup>. In a number of cases, the length of the amplified sections is limited by the DC resistance of the two-wire loop, the magnitude of which should not exceed 840 ohms under worst case conditions to provide for transmitting the remote power. For steel circuits with conductor diameters of 3 and 4 mm, this corresponds to 18.8 and 33.5 Km, while for VTSP and KSPP cable, 26.3 and 14.7 Km. For practical project planning, the DC resistance of the cable feed-ins and inserts should be taken into account where necessary.

The range of the V-3-3S equipment can be increased by approximately two times if a type PV-3-3 attended intermediate amplifier station is employed, which is included in the equipment complement of the V-3-3 long distance equipment. The PV-3-3, just as the OV-3-3S, is equipped with a flat-sloped ARU and has a transmit level of +16.5 dB (+1.9 Nep); the minimum receive levels of these stations are the same, -37.3 dB (-4.3 Nep) at a frequency of 31 KHz, or -54.7 dB

<sup>1</sup> The line sections in these tables are numbered in the B-A direction.

TABLE 4.11. The Lengths of Amplified Sections and the Communications Range When Multiplexing Steel Circuits with the V-3-3S Equipment (The Channels are Equipped with Companders)

Цепь Circuit		1. Кол-во НУП	2. Длины усилительных участков, км, для участка			3. Дальность связи, км	
d, мм	a, см		I	II	III		
3	20	0	0÷33,4	—	—	0÷33,4	
	30		0÷35,1	—	—	0÷35,1	
	60		0÷38,6	—	—	0÷38,6	
4	20		0÷40	—	—	0÷40	
	30		0÷42,1	—	—	0÷42,1	
	60		0÷47,1	—	—	0÷47,1	
3	20		1	8,4÷18,8	8,4÷18,8	—	16,8÷37,6
	30			8,7÷18,8	8,7÷18,8	—	17,4÷37,6
	60			9,7÷18,8	9,7÷18,8	—	19,4÷37,6
4	20	10÷33,5		10÷25	—	20÷58,5	
	30	10,5÷33,5		10,5÷26,3	—	21÷59,8	
	60	12÷33,5		12÷29,8	—	24÷63,3	
3	20	2		8,4÷18,8	8,4÷21	8,4÷18,8	25,2÷58,6
	30			8,7÷18,8	8,7÷21,7	8,7÷18,8	26,1÷59,3
	60			9,7÷18,8	9,7÷24,2	9,7÷18,8	29,1÷61,8
4	20		10—33,5	10÷25	10÷25	30÷83,5	
	30		10,5÷33,5	10,5÷26,3	10,5÷26,3	31,5÷86,1	
	60		12÷33,5	12÷29,8	12÷29,8	36÷93,1	

Key: 1. Number of unattended amplifier stations; 2. Lengths of the amplified sections, in Km, for a section of; 3. Communications range, in Km.

(-6.3 Nep) under especially severe conditions, and the other characteristics are the same. The PV-3-3 station can supply remote power to NUP's [unattended amplifier stations] with one NUP on each side. Two such stations can be installed in a bay.

A long line can be broken down into two sections by means of the PV-3-3 station: Terminal station -- One (two) NUP's -- PV-3-3, and PV-3-3 -- One (two) NUP's -- Terminal station. The PV-3-3 station makes it possible to increase the number of amplified sections up to six. So that noise in channels without companders does not exceed the permissible limits, the attenuation of the first amplifier sections in each stage (Table 4.10) should be decreased by 3 dB (0.35 Nep) when using the PV-3-3 station. For channels equipped with companders, this limitation is not applicable, but the overall communications length should not exceed 160 Km (on a steel circuit, d = 4 mm, a = 20 cm, Table 4.11).



TABLE 4.12. The Lengths of Amplified Sections and the Communications Range When Multiplexing Underground Single Quadded VTSP and KSPP Cables Using V-3-3S Equipment (Channels Without Companders)

Type of Cable Тип кабеля	Колич. НУП 1.	2. Длины усилительных участков, км для участков			Макс. дальность связи, км 3.
		I	II	III	
4. ВТСП 1×4×1,2	0	0÷25,2	—	—	25,2
5. ВТУ 21.3.59	1	8,4÷25	10÷17,4	—	42,4
	2	8,4÷23,5	10÷17,4	10÷16,3	57,2
4. ВТСП 1×4×1,2	0	0÷29,4	—	—	29,4
6. МРТУ 16.505.010-64	1	11÷26,3	12,7÷20,4	—	46,7
	2	11÷26,3	12,7÷21	12,7÷19,4	57 <sup>1)</sup>
7. КСПП 1×4×0,9	0	0÷23,2	—	—	23,2
	1	10÷20,6	11÷16	—	35,3 <sup>2)</sup>
	2	10÷14,7	11÷16,6	11÷14,7	40 <sup>2)</sup>

Key: 1. Number of unattended amplifier stations; 2. Lengths of the amplified sections, in Km, for sections of::; 3. Maximum communications range, Km; 4. VSTP 1 x 4 x 1.2; 5. VTU 21.3.59; 6. MRTU 16.505.010-64; 7. KSPP 1 x 4 x 0.9.

<sup>1</sup> The maximum communications range is less than the sum of the maximum lengths of the individual sections, since it is limited by the control range of the slope equalizer, which is inserted in the receiving equipment of the terminal station at B.

<sup>2</sup> The length of one of the amplified sections should not exceed 14.7 Km.

TABLE 4.13. The Lengths of Amplified Sections and the Communications Range When Multiplexing a VTSP (MRTU 16.505.010-64) Open Wire Cable Using the V-3-3S Equipment (Channels Without Companders).

Колич. НУП 1.	2. Длины усилительных участков, км			Максимальная дальность связи, км 3.
	I	II	III	
0	11÷26,2	—	—	26,2
1	11÷21,7	12,7÷15,2	—	36,9
2	11÷19	12,7÷15,8	11÷12,4	47,2

Key: 1. Number of unattended amplifier stations; 2. Lengths of the amplified sections in Km; 3. Maximum communications range, in Km.

Note: The swing in the temperature change of the cable over a year is taken as 80° C.

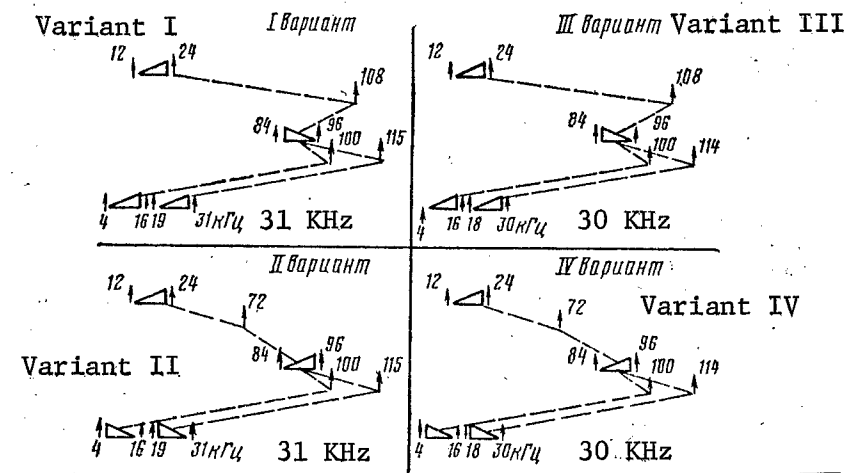

Figure 4.8. The group frequency conversion of the V-3-3S equipment.

Frequency Conversion and Line Spectrum: The individual conversion of the HF spectra of the three telephone channels is accomplished by carriers at 12, 16, and 20 KHz, and the upper sidebands are used for the transmission. The three-channel group occupying the 12 - 24 KHz passband is shifted in the first group conversion to an intermediate frequency range of 84 - 96 KHz (Figure 4.8). A carrier frequency of 108 KHz is used in this stage to derive variants I and II of the line spectrum, while for variants III and IV [sic, probable intention: 'variants III and IV'], a 72 KHz carrier is used. Following conversion, the corresponding upper and lower sidebands are used. The second stage of the group conversion serves for shifting the three-channel group from the intermediate frequency range of 84 - 96 KHz to the line spectrum. In all variants of the line spectrum, a 100 KHz carrier is used to convert the

TABLE 4.14. Group Carrier Frequencies, KHz

1. Ступени группового преобразования частот	2. Варианты линейного спектра			
	I	II	III	IV
Первая First	108	72	108	72
Вторая Second	100	100	100	100
3 направление А-В	114	114	115	115
4 направление Б-А	115	115	114	114

Key: 1. Group frequency conversion stages; 2. Line spectrum variants; 3. A-B direction; 4. B-A direction.

three channel group to the 4 - 16 KHz range for the lower A-B transmission direction, while for its conversion to the 18 - 30 KHz (variants I and II) range for the upper B-A direction, or 19 - 31 KHz (variants III and IV), carriers at 114 or 115 KHz respectively are used.

The group carrier frequencies required for deriving any line spectrum variant are given in Table 4.14.

#### Characteristics of the Channels:

Amplitude-frequency response with respect to the attenuation at  $f = 800$  Hz:

Response in excess, by no more than: 2.2 dB (0.25 Nep) (300 - 400 Hz, and 3,000 - 3,400 Hz)  
1.8 dB (0.2 Nep) (400 - 600 Hz, and 2,400 - 3,000 Hz)  
0.9 dB (0.1 Nep) (600 - 2,400 Hz)

Response low, by an amount no more than:

0.9 dB (0.1 Nep) (300 - 3,400 Hz)

Nonlinear distortion factor, no more than:

Total 2%  
Third harmonic 1%

Amplitude characteristic when the amplitude limiter is switched out

Flat within  $\pm 0.35$  dB (0.04 Nep), when the input level increases 7 dB (0.8 Nep) above the measurement level.

Internal noise voltage of the terminal equipment at the +4.3 dB level point, no more than

1 millivolt, psophometric

Isolation against audible crossovers between the channels, no less than

65 dB (7.5 Nep)

Isolation between the transmit directions of one channel at  $f = 800$  Hz, no less than

52 dB (6.0 Nep).

The call-up ringing and dial signals are transmitted via an extracted signal channel at a frequency of 3,835 Hz at a level 10.4 dB (1.2 Nep) below the measurement level. To protect the call-up and dial signal receiver against false actuation due to the speech signals, an amplitude limiter, Ogr, and a band exclusion filter, ZF, with maximum attenuation at the 3,825 Hz frequency (Figure 4.9) are inserted at the input of the telephone channel.

The call-up and dial signals are converted to a range of 12 - 24 KHz (15,825, 19,825 and 23,825 Hz respectively for the first, second and third channels), and then along with the ARU 12 and 24 KHz control signals are inserted in the channel at the input to the group equipment, bypassing the individual filters. The call-up and dial signals are converted by means of the individual modulators,  $M_1 - M_3$ , which are fed by the corresponding individual carriers, while the separation out of the upper sideband components being used is accomplished by filters  $F_1 - F_3$ . Amplifiers  $Us_1 - Us_3$  perform the functions of static relays. When the control contacts  $K_1 - K_3$  of the RSL [connector relay] are open,

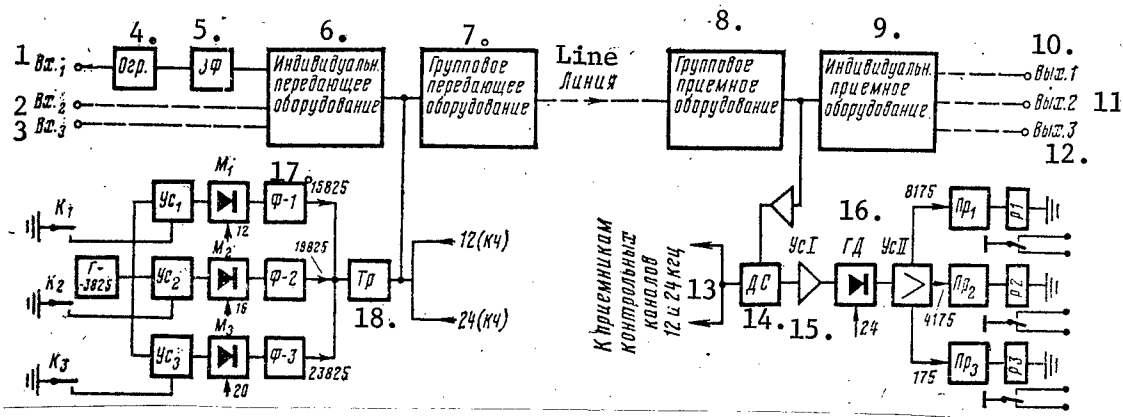

Figure 4.9. The call-up and dial signal transmission circuitry in the V-3-3S equipment.

- Key: 1. Input 1; 2. Input 2; 3. Input 3; 4. Ogr [limiter];  
 5. ZF [stop band filter]; 6. Individual transmitting equipment;  
 7. Group transmitting equipment; 8. Group receiving equipment;  
 9. Individual receiving equipment; 10. Output 1; 11. Output 2;  
 12. Output 3; 13. To the 12 and 24 KHz control channel receivers;  
 14. DS; 15. UsI, [Amplifier I]; 16. GD [group detector?];  
 17. F-1 [filter 1]; 18. Tr [transformer];  $\Pi p_1$  = Receiver 1;  
 $Yc_1$  = Amplifier 1;  $M_1$  = Modulator 1.

the amplifier of the given channel is cut off, and when closed, a 3,825 Hz signal is passed from the output of the G-3825 signal generator to the modulator input.

The call-up and dialing signals are separated out at the receive station along with the control signals, from the output of the group equipment, and are amplified by a common amplifier, UsI, which contains three resonant circuits. In the group demodulator, which is fed by the 24 KHz carrier signal, the 15,825, 19,825 and 23,825 Hz signals are converted to frequencies of 8,175, 4,175 and 175 Hz respectively. Following amplification by a common amplifier, UsII, to the output of which three resonant transformers are connected, the signals are fed to the inputs of the corresponding receivers,  $Pr_1 - Pr_3$ , which convert the AC pulse train to DC pulses. Inserted at the output of each receiver is an individual point relay,  $R_1 - R_3$ . The distortion in the transmitted pulses does not exceed  $\pm 6$  msec.

The generator equipment supplies the two systems with all the individual and group carrier signals. All the carriers and control signals are derived as a result of converting the main 4 KHz signal frequency, which is the product of dividing the frequency of a master 8 KHz crystal oscillator having a frequency stability of  $\leq 3 \cdot 10^{-5}$  (Figure 4.10). The individual 12, 16 and 20 KHz carriers are formed by multiplying the 4 KHz signal frequency, the 72 and 108 KHz group carriers are obtained by the sequential multiplication of the 12 KHz



in the heating circuit of thermistors. The change in the resistances of the working elements of the thermistors controls the flat gain and the slope of the frequency response of the receiving equipment. The ARU motors are powered from a 400 Hz transistorized generator.

The sensitivity of the ARU circuitry is  $\pm 0.35 - 0.6$  dB ( $0.04 - 0.07$  Nep), while the limits for flat and sloped control amount to no less than 26 and 20 dB respectively (3 and 2.3 Nep). The operation of the ARU circuit is blocked when the flat regulation control signal level changes sharply by more than  $\pm 3.5 - 5.2$  dB ( $0.4 - 0.6$  Nep), as well as when any of the control signals are lost. A provision is made for the capability of switching the ARU out and going over to manual control.

The intermediate unattended amplifier:

Amplifier characteristics:

Maximum gain at $f = 31$ KHz, no less than	34.7 dB (4 Nep)
Length of the preceding amplified section using a steel circuit, $d = 4$ mm, $a = 20$ cm:	
In the A-B direction	10 - 25 Km
In the B-A direction	10 - 33.5 Km
Maximum transmit level for the conditions "winter--dry" (with respect to power)	$+4.3 \pm 0.9$ dB ( $0.5 \pm 0.1$ Nep) flat within 0.43 dB (0.05 Nep) when the level is increased 13 dB (1.5 Nep) above the measurement level.

Attenuation through the feedback loop, no less than:

Within the useable passband	26 dB (3 Nep)
Outside the useable passband	17.3 dB (2 Nep).

The input impedance of the terminal and intermediate equipment on the line side is 800, 150 or 100 ohms. The return loss factor in the working passband does not exceed 20% for the terminal stations and 25% for intermediate ones.

The terminal stations are powered from the AC mains at 50 Hz and 220 or 127 volts (+10 to -20%). A station storage battery with a voltage of -24 or -60 volts (+20 to -10%) can serve as a standby power supply. Where -60 volt battery power supply is used, the equipment is connected to the -24 volt lead, while the remaining part of the battery is loaded into a ballast resistor for uniform discharging, where the ballast resistor is located at the input terminal blocks of the equipment. A provision is made for the ability to automatically switch the power supply over to the storage battery in case the AC mains voltage decreases or is lost, as well as the ability to switch back when the AC mains voltage is restored.

All equipment units are supplied with a regulated voltage of -19 volts  $\pm 2\%$ .

The power consumed by one terminal three-channel station when powered from the mains, from a -24 volt battery and a -60 volt battery, is 50, 35 and 85 watts respectively. Taking the power for the NUP [unattended amplifier station] into account, these power requirements increase to 75, 50 and 125 watts respectively.

The NUP is remotely powered by DC using a "wire--wire" configuration. In the case of two NUP's, each of them is powered from the nearest terminal station.

The power supply circuits for the amplifiers of two transmission directions are connected in series. The supply voltage at the NUP input can have any polarity and is 40 volts; the remote supply current is equal to 40 mA.

The remote supply voltage is derived at the terminal exchange by means of converting the regulated DC -19 volts, and is 80 volts. In the case of a loss of, or impermissible increase in the remote supply current, signaling actuates at the terminal station indicating a line break or short circuit.

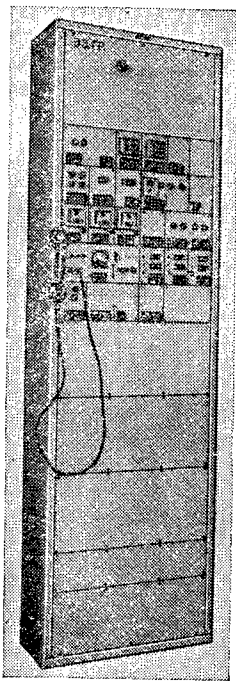

Figure 4.11.

General view of the V-3-3S terminal station equipment (for three channels).

Construction of the Terminal Equipment. The terminal equipment is housed in a rack with dimensions of 2,150 x 650 x 250 mm (Figure 4.11). The rack is made in the form of a cabinet without a front wall. Horizontal bottom plates (shelves) for mounting the plug-in blocks and connecting them into the station circuitry are installed between the vertical sides. The rack mounting is positioned in the side recesses of the chassis and in the internal recesses of the bottom plate. The mounting of the bottom plate is terminated at the front face with 8-jack sockets.

The equipment assemblies, made, as a rule, using pertinax [bakelite] printed circuit boards are built up in blocks. The mounting of each block is terminated at the front face with 8-jack sockets. The block is connected into the circuitry by means of two-pin plugs which connect the block mounting and the base.

The racks are produced already built-up with one or two three-channel stations. A rack with one station is designed for installation with the expansion option of a second station.

The weight of the rack built up with one or two three-channel stations does not exceed 105 and 185 Kg respectively.

The terminal equipment is intended for installation in heated rooms where the ambient temperature varies from +10 to +40° C and at a humidity of up to 80%.

The rack is equipped with visual and audio signaling, a PVU call-up and intercom unit, and an instrument for the entire rack which consists of an 800 Hz

generator and a switchable voltmeter, making it possible to measure levels within limits of  $\pm 6$  dB ( $\pm 0.7$  Nep), as well as the AC and DC supply voltages, carrier levels, etc.

The NUP construction is designed for the capability of installing it in unheated rooms. A NUP is made in the form of a metal base with brackets for securing it to the wall. The blocks are positioned between two side walls and are enclosed by a housing. All the blocks are hermetically sealed at the point where the housing makes contact with the base, a rubber gasket is provided, and the cable is brought in through seals.

Placed in the NUP is the intermediate equipment for one three-channel system. The NUP dimensions, including the brackets, are 335 x 295 x 560 mm, and the weight is 20 Kg.

The audio channel passband is limited to 2,700 Hz; since the audio channel is not designed for passing inductive dialing and inductive ring-up signals, it can be used only as an auxiliary channel, for example, for service communications. The audio channel at terminal stations and NUP's is provided with a transformer having the center tap brought out for DC telegraphy in case remote power is lacking.

The equipment complement. Included in the complement of the main equipment are:

- The terminal station with ARU, the OV-3-3S with the power supply (PU) and matching autotransformer (AT);
- The unattended amplifier station, NUP V-3-3S, with devices for the transmission and conversion of the remote power (DP and PDP), which are installed at the terminal station.

Supplied on separate order are:

- The complex of blocks for extending the terminal station with ARU, including the PU and AT, and providing for the derivation of three additional channels (without generator equipment);
- Line matching units (the LUS's);
- The compander block;
- The block for equalizing curvilinear distortions, the VKr, (used for equalizing the frequency response of the cable in a range of 4 - 16 KHz).

#### 4.8. The VO-3-4 Equipment

Function. The equipment is intended for multiplexing steel circuits, as well as nonferrous metal circuits, with three HF telephone channels in a spectrum up to 30 - 31 KHz. Any of the telephone channels, having an effective transmission passband of 300 - 3,400 Hz, can be multiplexed with multichannel telegraph signals.



Four variants of the line spectrum are provided in the equipment: A, B, C and D, (Figure 4.12.). Just as in the V-3-3S equipment, the telephone signals are transmitted in the lower channel group (the A-B direction) in the 4 - 16 KHz spectrum, and in the upper channel group (the B-A direction) in the 18 - 30 or 19 - 31 KHz bands. Variants A and D coincide with variants I and IV respectively of the line spectrum of the V-3-3S equipment, while variants B and C differ from variants II and III of the V-3-3S by the frequency inversion in the lower group. Also provided in the line spectrum of the VO-3-4 equipment are sections 480 Hz wide for the capability of organizing 3 - 4 tone telegraphy channels outside the passband of the telephone channels (these are not used on a rural network). Transmitted via the line in the A-B and B-A directions for all line spectrum variants are the control signals for the ARU at 16.11 and 31.11 KHz respectively, and the monitor measurement signals at 3.81 and 17.81 KHz for measurements and manual control.

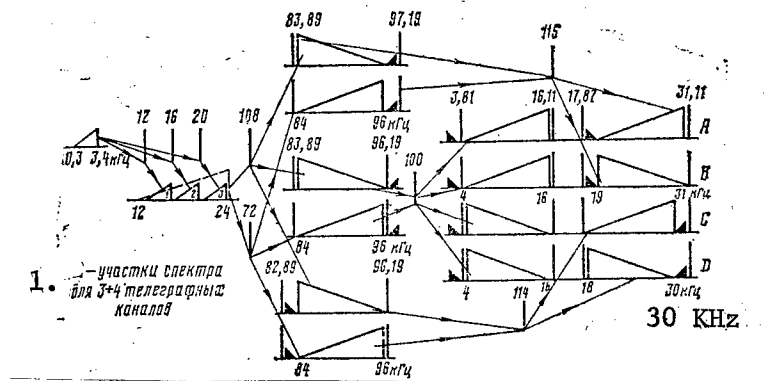

Figure 4.12. The frequency conversion and line spectrum of the V-3-4 equipment.

Key: 1. Sections of the spectrum for three to four telegraph channels.

A provision is made on steel rural communications circuits for the use of terminal and intermediate stations of both the unattended and the attended types. Terminal stations (VBO-3-4) [Latin letters used for VBO, NBO and FBO equipment designations] are equipped with a single frequency flat-sloped ARU and have a transmit level of +16.5 dB (1.9 Nep) (with respect to power). Unattended intermediate amplifier stations with a remote power supply (NBO-3-3) do not contain ARU devices and are designed for a nominal (maximum) transmit level of +4.3 dB (0.5 Nep) (with respect to power). An attended intermediate amplifier station (FBO-3-2), just as the terminal station, is equipped with an ARU, and has a transmit level of +16.5 dB (1.9 Nep). The minimum receive level at a frequency of 31 KHz for terminal and attended intermediate stations is -49.5 dB (- 5.7 Nep).

Using terminal stations and NUP's, it is possible to organize communications with two or three amplified sections. The application of attended intermediate stations makes it possible to increase the number of amplified sections up to

four to six. The maximum number of NUP's between two terminal stations, or between a terminal and attended intermediate station, is two. Each NUP is powered remotely from the nearest terminal or attended intermediate station. To suppress noise in the telephone channels, and increase the range, a provision is made in the equipment for the option of using companders.

The transmit and receive levels, the characteristics of the amplifiers and the equalizing devices of the VO-3-4 equipment coincide or are close to similar data for the V-3-3S equipment. In establishing the communications range and the lengths of amplified sections in various cases, the applications for VO-3-4 equipment can be guided by Table 4.10 and 4.11, which are given for the V-3-3S equipment.

The equipment is supplied by the Hungarian firm, Budavox.

Frequency conversion and generator equipment. The frequency conversion circuitry is configured just as in the V-3-3S equipment, based on a three channel 12 - 24 KHz group using an intermediate frequency range of 84 - 96 KHz (Figure 4.12). The distinction noted in the line spectra is explained by the fact that in variants B and C, used as carriers in the VO-3-4 equipment during the first group conversion are 108 72 KHz respectively, at the same time as the 72 and 108 KHz carriers are used in the II and III variants of the V-3-3S spectrum. So that the values of the control frequencies on the line for all spectrum variants are the same, fed to the input of the second group conversion stage in the transmitting equipment at a level 15 dB below the measurement level are control signals at the following frequencies: at station A, 83.89 and 96.19 KHz; at station B, 83.89 and 97.19 KHz for line spectrum variants A and B, and 82.89 and 96.19 KHz for variants C and D. The ARU line control signals at 16.11 and 31.11 KHz are derived by converting the 82.89 and 83.89 KHz generator control signals, while the line monitor and instrumentation signals for manual control at 3.81 and 17.81 KHz are derived as a result of converting the 96.19 and 97.9 KHz generator control signals.

A thermostatically controlled crystal oscillator at 4 KHz is used as the master oscillator. The individual carriers at 12.16 and 20 KHz, and the group carriers at 72 and 108 KHz are derived from the 4 and 12 KHz harmonic generators respectively. The group carriers at 100, 114 and 115 KHz are derived from individual thermostatically controlled crystal oscillators. The instability in the 4 KHz master oscillator and group carrier generators does not exceed  $2 \cdot 10^{-6}$ /month following continuous operation for half a year. All four control signals are generated by individual crystal oscillators which are not thermostat controlled, having a frequency instability of no more than  $4 \cdot 10^{-5}$ /month.

#### Channel Characteristics:

Amplitude-frequency distortion in the 300 - 3,400 Hz range      Within limits of 2/5 of MKKTT standards

Total nonlinear distortion, no more than      2 %.

Amplitude response when the amplitude limiters are switched out	Straight line within $\pm 0.3$ dB (0.035 Nep) when the input level increases 7 dB (0.8 Nep) above the measurement level
Internal noise voltage of the terminal equipment at the +4.3 dB (+0.5 Nep) level point, no greater than	0.7 millivolts, psophometric
Isolation from audible crossovers between channels, no less than	65 dB (7.5 Nep)
Isolation between transmission directions for one channel at $f = 800$ Hz, no less than	54 dB (6.2 Nep).

The call-up and dial signal transmission system is designed around a universal circuit configuration and operates both in the passband of the telephone channel at 2,100 Hz, and outside the passband at a frequency of 3,825 Hz. In both cases, the signals are transmitted via the HF channel at a level 6 dB (0.7 Nep) below the measurement level. A provision is made for the capability of changing over from one operational variant to another by means of resoldering.

In the second variant, the transmitting equipment consists of a 3,825 Hz oscillator and three, according to the number of channels, static relays. The output of each relay is connected to the line for the corresponding channel at the point between the output of the D-3.4 filter, which serves for protecting the signal channel against noise from the telephone signal side, and the input of the individual modulator. When the "ground" potential arrives from the RSL [connector relay], the static relay opens and passes the signal from the 3,825 Hz oscillator to the input of the individual modulator. On the receive side, the receiver for the signal channel is connected to the telephone channel line at the point between the output of the audio amplifier and the input of the D-3.4 receive filter. Connected at the output of the receiver is a hermetically sealed reed type relay which forwards the transmitted DC pulses to the RSL. The distortion in the pulses transmitted via the signal channel does not exceed  $\pm 6$  msec. A provision is also made in the signal channel receiver for an electronic output, which permits replacing the receive, hermetically sealed relay with an external RPN type relay. The pulse distortions in this case increase to +10 msec and -15 msec.

In contrast to the signal channel of the V-3-3S equipment, in which the dial and call-up signals are introduced into the transmission line and are brought out from it following and prior to the individual frequency conversions respectively, i.e. in the 12 - 24 KHz spectrum, avoiding the channel filters for transmit and receive, in the VO-3-4 equipment these signals are fed to the input of the individual modulator, and are picked off from the output of the audio amplifier. In comparison with the V-3-3S equipment, the channel filters of which are designed for passing only the converted telephone signals in a passband of from  $f_c + 300$  to  $f_c + 3,400$  Hz (where  $f_c$  is the individual carrier

frequency), the upper limit of the passband for the channel filters of the VO-3-4 equipment has been shifted up to  $f_c + 3,825$  Hz to assure passing the call-up and dial pulses.

The single frequency, flat-slope ARU is of an electromechanical type with variable equalizers, which can be controlled by means of a motor-capacitor block. Used in the 3.81 KHz control channel receiver is a filter using coils and capacitors, while in the receivers of the remaining three control channels, single stage crystal filters are employed. The control range of the flat ARU at 16 KHz amounts to 23.5 dB (2.7 Nep), while the control range for the slope ARU in the lower group is 16.5 dB (1.9 Nep). The control range of the flat ARU at 31 KHz is 41 dB (4.7 Nep), while the control range for the slope ARU in the upper group is 21 dB (2.4 Nep). Additionally, in each of the two transmission directions, an additional manual slope control of 11.3 dB (1.3 Nep) is provided in steps of 1.3 dB (0.15 Nep) each. When the level of the control signal decreases by 2.7 - 3.4 dB (0.3 - 0.4 Nep), the ARU is blocked. At the extreme end positions of the motors, the ARU actuates signaling which indicates that the control limits have been exhausted.

#### The Intermediate Unattended Amplifier

##### Amplifier characteristics:

##### Maximum gain, no less than

At $f = 31.11$ KHz	33 dB (3.8 Nep)
At $f = 16.11$ KHz	22.6 dB (2.6 Nep)

##### Maximum slope of the gain in the passband:

Of the upper group of channels	12.2 dB (1.4 Nep)
Of the lower group of channels	15.6 dB (1.8 Nep)

##### Maximum transmission level (with respect to power) for "winter-dry" conditions

+4.3 dB (0.5 Nep)

##### Overload level

+20 dB (+2.3 Nep)

##### Feedback loop attenuation, no less than:

In the useable passband	20 dB (2.3 Nep)
Outside the useable passband	17.4 dB (2.0 Nep).

The input impedance of the terminal and attended intermediate stations is 800, 600, 150 or 100 ohms; the input impedance of an unattended amplifier stations (a NUP) is 100, 150 or 800 ohms for a return loss factor of no more than 10%.

The electrical power supply for the blocks of the terminal and attended intermediate stations is from the mains at 50 Hz  $\pm$  5% and 110, 127, or 220 volts  $\pm$  10%, while the power for the signaling circuits of these stations is from a -24 volt (+15%, -10%) DC source; when mains power is lost, the power supply

for the equipment blocks automatically switches over to -24 volts DC (+15%, -10%) or -21.2 volts  $\pm$  3%.

A power supply mode is provided for the stations using only -24 volts DC (+25%, -10%) without using the mains.

Appended to stations of the first production series was a separate block, by means of which it is possible to organize the power supply for these stations from -60 volt ATS batteries using a tap at the -24 volt point. In this case, when the mains power is lost, the power supply of the given station is automatically switched over to the -24 volt tap, while an auxiliary block connects a ballast load to the battery between the -60 and -24 volt points, and provides for its uniform discharging, as well as the signaling and protection of the equipment against overvoltages at the moment of switching. The dimensions of the block are 490 x 640 x 225 mm, and the weight is no more than 28 Kg. In stations of a later production series, all the power supply units are housed in the rack along with the remaining equipment.

Remote powering of a NUP is accomplished using DC in a "wire--wire" circuit configuration. The remote power supply current is 40 mA, while the nominal voltage is 45 volts. The NUP can be powered with a voltage of any polarity, and the NUP can be fed from any end. The transmitting unit, which can be installed at a terminal or attended intermediate station, provides for feeding a supply voltage of 50 - 90 volts into the line, and controlling the remote power supply current, and is also equipped with a signaling system which actuates when the current changes by  $\pm$  30%. One transmitting complex can provide remote power for two NUP's operating on different circuits. One such complex can be installed at a terminal station, while at an attended intermediate station, two such complexes can be installed. The complex for transmitting the remote power is mounted along with the NUP.

The structure of terminal and attended intermediate stations: The 12 channel terminal equipment is housed in a rack with dimensions of 2,100 x 660 x 250 mm, while an attended intermediate station is placed in a rack with dimensions of 2,600 x 660 x 250 mm. The equipment is made in the form of removeable (slide out) block, which are connected to the rack installation by means of two-pin plugs, inserted from the front. Parallel jacks are provided on the two-pin plugs for the connection of measurement instruments.

Placed above the terminal rack are the protection devices, the power supply terminals and the input terminal block boards. Then follows the generator equipment, the unit for feeding the remote power, and other blocks. Placed below the rack are the power supply block, the differential systems, companders, etc. A neper meter and other instruments, a jack field, switches for switching the signaling system, controls for the residual attenuation of the channels, signal lights, as well as a slide out desk top are placed in the central part of the rack. One terminal three-channel station is placed in a terminal rack, and two intermediate stations are placed in an intermediate rack.

The equipment is designed for operation in heated rooms with a variation in the ambient temperature of +10 to +40°C, and with a humidity of less than 80% at 20° C for no more than two months out of the year. The weight of one terminal or one attended intermediate rack with a full equipment complement is no more than 350 Kg.

The terminal and intermediate racks are equipped with visual signaling which actuates when the power supply is lost, fuses burn out, in case of a deviation from the permissible limits of the control signal levels cited above ( $\pm 2.7 - 3.4$  dB [ $\pm 0.3 - 0.4$  Nep], actuation delay of 10 seconds), in the remote power supply current, etc.; additionally, monitored at terminal stations are the overheating or insufficient heating of the thermostats of the crystal oscillators and the output level of the common signal channel oscillator. A provision is made for the ability to feed emergency signals from the racks to the common rack visual or audio signaling system.

An intercom and call-up unit, PVU, and a neper meter are provided at terminal and attended station racks. The neper meter of a terminal station consists of an audio generator with stepwise control of the output level and frequency within limits of  $-17.3$  to  $4.3$  dB ( $-2.0$  to  $0.5$  Nep), and  $300 - 3,400$  Hz, as well as a wide band level meter for a frequency range of  $0.3 - 150$  KHz with the capability of varying the level within limits of  $-52$  to  $18.2$  dB ( $-6.0$  to  $2.1$  Nep) and with a  $135, 150, 600$  ohm and high impedance inputs. The neper meter of an intermediate station consists of an oscillator at three fixed frequencies of  $0.8$  KHz (with a zero output level and  $600$  ohm output impedance),  $9.5$  and  $24.5$  KHz, and the output level is  $-21.7$  dB ( $2.5$  Nep) (the output impedance is  $150$  or  $600$  ohms) and the same level meter as at a terminal station.

The structure of a NUP is designed for the installation of equipment on a wall or telegraph pole. The NUP is made structurally in the form of a hermetically sealed container, which consists of a vertical cylinder and a box placed beneath it. Placed in the cylindrical part of the structure are amplifiers, filters and equalizers, while input and protective devices are placed in the box. The basic data for the NUP structure are given in Table 4.15.

TABLE 4.15. Structural Data for Unattended Amplifier Stations

Высота, мм <u>Height, mm</u>	620
Поперечные размеры, мм <u>Cross sectional dimensions</u>	460×440
Масса, кг <u>Weight, Kg.</u>	54

The NUP construction is designed for equipment operation in the open with fluctuations in the ambient temperature of up to  $\pm 50^\circ$  C. The container is fastened to a telegraph pole by means of a collar clamp. A provision is

made for the possibility of mounting two containers on a pole. In this case, the containers are positioned on the pole with the rear walls facing each other and no collar clamps are used. During alignment and installation, as well as repair work, access is provided into both parts of the structure. The cylindrical housing is shifted upward on guides for this purpose. The overall height of the structure when the housings are opened and locked is 1,230 mm.

A portable measurement instrument can be used for aligning the NUP, which consists of a level meter with measurement limits of -17.3 to 26 dB (-2 to +3 nep) in a frequency range of 0.3 - 40 KHz, and having 100, 150, 600, 800 ohm and high impedance inputs, and also consists of a DC voltmeter with measurement ranges of 25, 50 and 100 volts.

A block of balancing line filters is employed when equipping the channel with audio amplifiers. The block is designed for installation in standard racks. The passband of the audio channel is limited to 2,400 Hz. In all stations, the audio channel is equipped with transformers having a center tap, which can be used for DC telegraphy in the absence of a remote power supply. Just as in the V-3-3S equipment, the audio channel can be used only for service communications, with the only exception that where balancing filters are present, this channel can be equipped with amplifiers.

The line matching and protective device is intended for matching the impedance of an 800 ohm stell circuit to the 150 or 100 ohm cable input impedance, and consists of a matching autotransformer, blocking and drainage coils, two R-350 discharges, one spark discharger, and two fuses. The device is installed at the input cable support and is designed for operation with an ambient temperature change of from -50 to +50° C, and humidity of up to 98%.

The equipment complement:

- A VBO-3-4 terminal rack, set up with one three-channel station; a type A or B with the requisite spectrum variant (A, B, C or D) and differential systems (I, II or III) are supplied in accordance with the order; the following can be supplied along with the rack in accordance with the order:
  - a) companders,
  - b) block of balancing line filters,
  - c) auxiliary 60 volt supply block,
  - d) line matching and protective unit;
- A FBO-3-2 attended intermediate station rack; the rack is supplied for operation on a steel or nonferrous metal circuit in accordance with the order and set up with equipment for one or two three-channel systems; the following can also be supplied along with the rack in accordance with the order:
  - a) one or two remote power complexes,
  - b) block of balancing line filters,
  - c) auxiliary 60 volt supply block,
  - d) two or four line matching and protective devices;

-- A NBO-3-3 unattended amplifier station (NUP); it is supplied along with a remote power complex consisting of a remote power transmission block and a block of remote power filters, and with a portable measurement instrument, as well as with a line matching and protective device on special order.

#### 4.9. The KNK-6S Equipment

Function: The KNK-6S equipment is intended for multiplexing one cable pair with six telephone channels. Included in the equipment complement are terminal and intermediate unattended, remotely powered, amplifier stations (NUP's). The maximum length of an amplified section for a single quadded VTSP cable, fabricated in accordance with TU 21-3-59, is 14 Km, and is 16 Km for a VTSP cable fabricated in accordance with MRTU 16.505.010-64. The maximum number of amplified sections is four. When multiplexing two pairs of VTSP cables, and using two terminal and three intermediate stations, the equipment permits the organization of 12 telephone channels with an effective transmitted passband of 300 - 3,400 Hz and a maximum range of up 56 - 64 Km.

The equipment is intended for multiplexing a single quadded VTSP cable. The use of companders in the equipment also permits using it for multiplexing multipair audio cables of the TZ and TZB types. In this case, the equalizers which are made in accordance with the frequency characteristic of the given type of cable are replaced in the equipment.

The terminal equipment is housed in heated rooms at an ambient temperature of +10 to +40° C and a relative humidity of 45 - 75% (80% is permitted for 10 hours), while the intermediate equipment is buried in the ground at the cable laying depth.

The joint operation of the KNK-6 equipment with other systems on one cable is not permitted.

The equipment is supplied by the Czechoslovakian company, Tesla.

The frequency conversion and line spectra: The individual frequency conversion in the transmitting equipment is realized by phase difference modulators, the phase shifting four pole networks of which are designed around resistors and capacitors. Using individual carriers at 80, 88, 96, 104, 112 and 120 KHz, the telephone channel passbands are shifted from the 0.3 - 3.4 KHz range to the 76 - 120 KHz band (Figure 4.13). The lower sidebands are employed for the transmission, while the upper sidebands are suppressed by no less than 26 dB (3 Nep). Each of the carrier signals is suppressed at the output of the individual equipment by no less than 17.3 dB (2.0 Nep). A passband of 8 KHz is set aside in the line spectrum for each telephone channel.

The resulting six channel group, which occupies a frequency range of 76 - 120 KHz, is transmitted directly via the line in the B-A direction (to the regional center). For transmission in the opposite A-B direction (from the regional



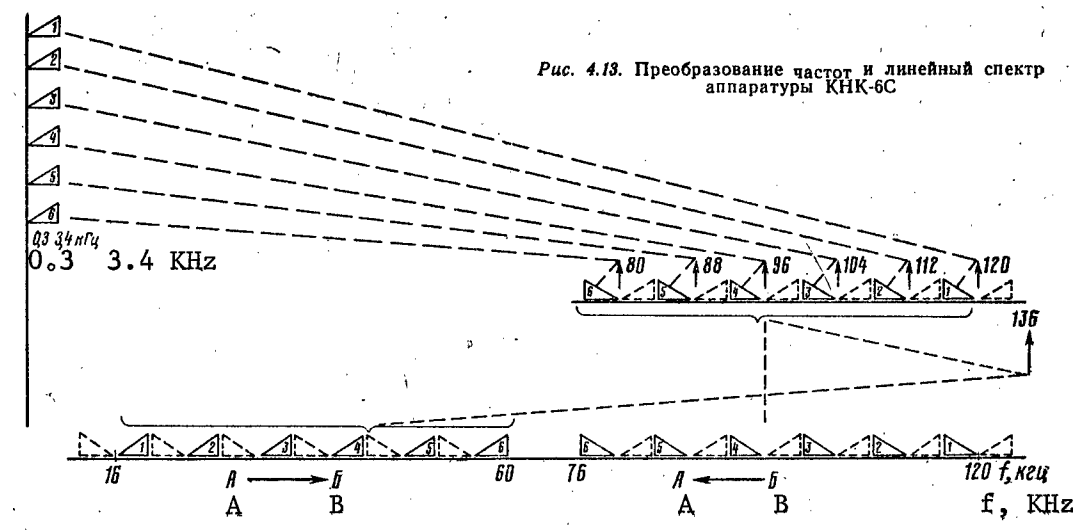

Figure 4.13. The frequency conversion and line spectrum of the КНК-6S equipment.

center), the six channel group is converted by means of the group carrier frequency at 136 KHz to the 16 - 60 KHz range (Figure 4.13).

Transmit and receive levels: The equipment works with a preliminary slope of the transmit levels which corresponds to the slope of the frequency characteristic of the amplified section of a cable of maximum (nominal) length (Figure 4.14).

#### Channel Characteristics:

Nominal (maximum) transmit levels at the output of the terminal and intermediate station (with respect to power):

Via channel No. 6, A-B ( $f = 56.8$ KHz)	+21 dB (2.4 Nep)
Via channel No. 1, B-A ( $f = 119.2$ KHz)	+13 dB (1.5 Nep)

Slope of the transmit levels<sup>1</sup>

In the lower group of channels	15.2 dB (1.75 Nep)
In the upper group of channels	8.5 dB (1.0 Nep)

Nominal receive level

For the lower group of channels	-56.5 dB (-6.5 Nep)
For the upper group of channels	-61.7 dB (-7.1 Nep)

<sup>1</sup> In the lower channels of the spectrum for the lower and upper directions, the transmission is realized at lower levels.

Nominal attenuation of an amplified section  
at  $f = 120$  KHz

48.6 dB (5.6 Nep)

Minimum possible receive level

-67 dB (7.75 Nep).

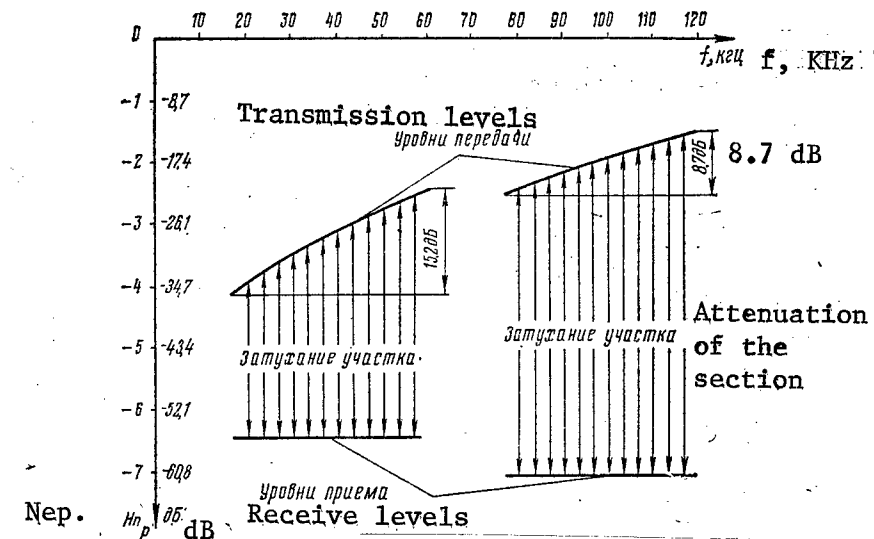

Figure 4.14. Transmit and receive levels of the KNK-6S equipment.

To suppress the noise arising as a consequence of using the comparatively low transmit and receive levels, the equipment is outfitted with companders, which increase the noise immunity by 17.3 dB (2 Nep).

Channel Characteristics:

The amplitude-frequency distortion in the 300 - 3,400 Hz passband Within limits of 2/5 MKKTT norms

Total nonlinear distortion (taking into account the companders), no more than 5%

Amplitude response Straight line within 0.3 dB (0.035 Nep) when the input level increases by 3.4 dB (0.4 Nep) above the measurement level

Isolation against audible cross-overs between the channels, no less than 65 dB (7.5 Nep)

The transmission of the call-up and dial signals is realized via an extracted signal channel at 3,850 Hz at the measurement level. Miniature relays are

used to connect the 3,850 generator signal to the channel input, and to receive the call-up and dial signals. The contacts of the transmitting relay are made from an alloy of gold and nickel. The distortion of the pulses transmitted via the signal channel does not exceed  $\pm 6$  msec for level fluctuations of  $\pm 1.7$  dB ( $\pm 0.2$  Nep) and a change in the signal frequency of  $\pm 10$  Hz.

The generator equipment provides for the derivation of six individual carrier frequencies at 80, 88, 96, 104, 112 and 120 KHz, a group carrier frequency of 136 KHz, as well as the 3,850 Hz signal channel frequency. The generator equipment is designed for feeding four six-channel systems. All carrier frequencies are derived by multiplying the 8 KHz frequency for both the odd and even harmonics. Synchronization of the carrier frequency of the terminal stations is provided in the equipment. At the synchronizing (controlling station) the 8 KHz signal is derived from a master crystal oscillator, while at the synchronized (controlled) station, it is derived from a synchronized LC oscillator. Reserved in the generator equipment is the derivation of the main 8 KHz signal, the group 136 KHz carrier and the 3,850 signal frequency.

Carrier frequency synchronization: Under normal conditions, the synchronizing station is station A, while the synchronized one is station B. At station A, the 120 KHz control signal is fed to the input of the group equipment, and then converted in the group modulator by means of the 136 KHz carrier to the 16 KHz line synchronization signal, which is also forwarded along the line to station B. At station B, the isolated and amplified 16 KHz signal is used for synchronizing the 8 KHz LC oscillator. To facilitate the synchronization for the subharmonic, a diode is inserted at the oscillator input.

When the 16 KHz synchronizing signal is lost, station B automatically switches over to the synchronizing mode, while station A switches over to the synchronized station mode. In this case, the 120 KHz synchronization signal is fed via the line from station B to station A, where this signal is derived from an 8 KHz crystal oscillator. At station A, the 120 KHz signal separated out by a crystal filter, is converted by means of a 112 KHz carrier in a separate modulator to an 8 KHz signal, which is further utilized for synchronizing the 8 KHz LC oscillator.

For the case where several radial links are organized from a regional center (i.e. with system branching) using the KNK-6S equipment, under normal conditions station A transmits the 16 KHz synchronization signal to all peripheral B stations. One of the directions in this case is the main one. If at the station B for the main direction this 16 KHz synchronization signal is lost, then this station automatically switches over to the synchronizing mode and begins to feed a 120 KHz signal to station A, which becomes the synchronized one. In this case, station A continues to forward the 16 KHz signal to all the remaining B stations, i.e., remains the synchronizing station with respect to them.

However, if the 16 KHz synchronization signal is lost at a B station for one of the directions other than the main one, the circuit for deriving the carrier frequencies at this stations automatically switches over to a crystal oscillator. In this case, stations A and B operate in the given direction without synchronization. The frequency instability of the 8 KHz crystal oscillator when the ambient temperature changes from +10 to +40° C, does not exceed  $\pm 1$  Hz, while the divergence of the frequencies in the upper channel spectrum can run up to 30 Hz in this emergency mode.

The 16 and 120 KHz synchronization control signals are fed via the line at the measurement level.

Monitoring, switching and signaling: The control panel, which is provided in the terminal equipment, permits the following:

- Monitoring the DC supply voltages and input levels of the carriers, the crystal and LC oscillators, as well as the level of the 8 KHz amplifiers and the 3,850 Hz signal channel oscillators on a meter;
- Monitoring the proper operation of the individual receiving-transmitting equipment by means of checking it "into itself";
- Monitoring the correct operation, and carrying out the alignment and switching of synchronization channels;
- Monitoring the correct operation and carrying out the switching of the generator equipment to standby;
- Organizing service conversations via the HF channels or via a special service circuit.

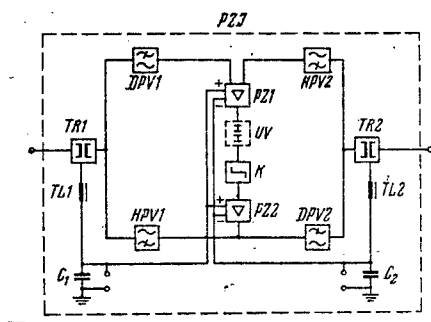

Figure 4.15. Skeleton schematic of the intermediate amplifier of the KNK-6S equipment.

Monitoring the correct operation of the equipment and synchronization is realized by means of signal lights, which indicate the nature of a fault.

The intermediate amplifier (Figure 4.15) consists of two two-pin guide plug HF and audio filters (DPV1, HPV1, DPV2, HPV2), which split the transmission directions, a preslope circuit (K), which provides for the tilting of the output levels, an artificial line (UV), which supplements the attenuation of the amplified sections of the cable up to the nominal value where necessary, input and output transformers (Tr<sub>1</sub>, Tr<sub>2</sub>), which match the amplifier to the line and organize the remote power and service communications using the center taps and the amplifier. The amplifier, consisting of two blocks (PZ1, PZ2) works in a frequency range of 16 - 120 KHz, and simultaneously amplifies signals fed in two opposite transmission directions.

Amplifier characteristics:

Nominal gain at $f = 120$ KHz	48.6 dB (5.6 Nep)
Maximum gain	54.3 dB (6.25 Nep)
Amplitude response characteristic	When the output level increases up to 8.5 dB (+1.0 Nep), it is flat within 0.43 dB (0.05 Nep)
Suppression of second and third harmonic nonlinearity at an output level of -6.9 dB (-0.8 Nep)	No less than 52 and 69.5 dB respectively (6 and 8 Nep)
The internal noise level of the amplifier referenced to its input	126 dB (-14.5 Nep) <sup>1</sup>

The group channel of the system is designed taking into account the cross-overs in the multiquadded cable at a specific noise power of 10 picowatts/Km, i.e. at a noise power in the channel of 1,000 picowatts for a communications length of 100 Km. Considered in the calculation was the suppression of noise by compander devices.

The nominal input impedance of the intermediate and terminal equipment can be set at 120 or 150 ohms by means of resoldering (for a VTSP cable, 120 ohms). The return loss factor does not exceed 40%.

The frequency response characteristics of the line are equalized in the intermediate and terminal equipment by means of supplementing the attenuation of the amplified sections of the cable with the attenuation of artificial lines, up to the attenuation of a section of nominal (maximum) length. The artificial line of an intermediate station corresponds to 1/8 of the nominal length of an amplified section. Insofar as one artificial line is provided in the intermediate amplifier for the simultaneous control of the levels in two transmission directions, the lengths of the amplified sections between NUP's can vary within limits of 7/8 - 1 of the nominal length.

The length of an amplified section associated with a terminal station can be selected at any value, but not above the nominal. This adjustment is accomplished by means of resoldering the setting of the artificial lines, provided in the terminal equipment, in steps of 1/8 of the nominal section length each. To equalize the scattering in the frequency response characteristics of the cable and equipment, as well as the frequency distortion due to reflections, an additional equalizer is provided in the receive section of the terminal equipment. Additional equalization is performed at both station A and station B in a frequency range of 76 - 120 KHz.

Seasonal changes in the attenuation of a VTSP cable over one amplified section of nominal length, which are caused by annual fluctuations in the ground

<sup>1</sup> At the minimum receive level of 62 dB (7.15 Nep), this corresponds to a noise power of 47 picowatts at the output of the channel at a point with a relative zero level.

temperature within limits of from  $-5$  to  $+19^{\circ}$  C, reach 2.8 dB (0.32 Nep) at a frequency of 120 KHz, and 2.3 dB (0.26 Nep) at 60 KHz. The seasonal fluctuations in the line attenuation are compensated at the terminal station by means of group, flat regulation within limits of  $\pm 2.7$  dB ( $\pm 0.3$  Nep), as well as by means of adjusting the residual attenuation of the channels within limits of  $\pm 6$  dB ( $\pm 0.7$  Nep).

The equipment is powered from the AC mains at 50 Hz and 220 volts  $\pm 3\%$ . The equipment assemblies are powered by rectified voltage at -24, -12 and -9 volts. Supplied along with the equipment is the ST-250.4 alternating current regulator, which makes it possible to extend the permissible limits for the fluctuation of the mains voltage to  $+10$  to  $-15\%$ . The terminal bay, which is outfitted with two or four six-channel systems, uses a power of no more than 75 watts (90 VA), and along with the regulator, no more than 175 watts (260 VA).

The remote powering of the intermediate amplifiers is realized from a terminal station via a single quadded cable phantom circuit ("pair--pair" circuit) using DC in a series circuit configuration. The remote supply current is 20 m and the voltage drop for each amplifier is 15 - 18 volts. The remote power supply at a voltage of  $\pm 60$  volts is designed for powering up to three NUP's in each of four six-channel systems. Also provided is the capability of powering the amplifiers in a "pair--ground" circuit configuration, and via a phantom circuit using an unmultiplexed pair (for multipair cables) as the return conductor.

Service communications between terminal and intermediate stations are organized via a single quadded cable phantom circuit. The telephone unit for service communications is made portable and can be used both at terminal and intermediate stations. For the case of conversation with an intermediate station, the set is powered dry batteries at 9 volts. The call-up is made by voice. A loudspeaker is used for reception. When transmitting, this same loudspeaker is used as a microphone. The set provides for service communications via a channel with up to 45.2 dB (5.2 Nep) of attenuation.

The sensitivity of the service communications circuit can be increased by means of inserting a standard MB [local battery] set in the portable set. In this case, magneto ringing is not permitted.

Construction of the terminal equipment: The equipment is made in two structural variants. The equipment for four six-channel systems (Figure 4.16) is housed in a ST-4 rack with dimensions of 2,600 x 625 x 225 mm, while the equipment for two six-channel systems (Figure 4.17) is placed in a ST-2 rack with dimensions of 2,120 x 625 x 225 mm. The weight of a fully equipped ST-4 bay is 275 Kg, while for a ST-2, it is 185 Kg. The bays are made in the form of welded racks of formed steel sheet. The faces of the racks in the upper and lower parts are closed off with removable double-leaf doors.

The individual assemblies of the equipment are made in the form of blocks with a rear inset. In the majority of blocks (with the exception of the

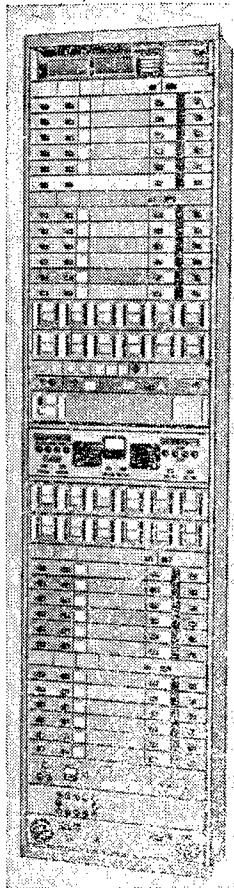

Figure 4.16. General view of the KNK-6 terminal station equipment (a ST-4 rack for 24 channels).

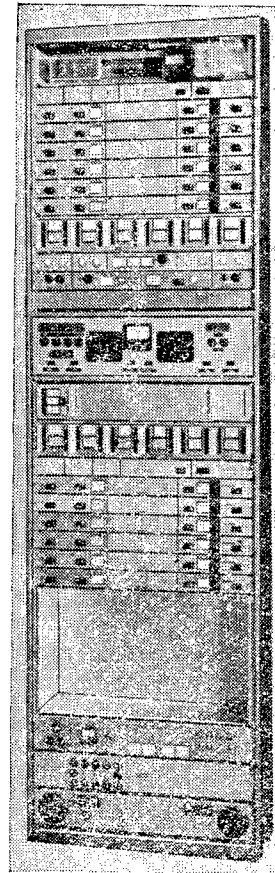

Figure 4.17. General view of the KNK-6 terminal station equipment (a ST-2 rack for 12 channels).

rectifier, the device for transmitting the remote power, and a few others), printed circuit boards are employed. The inset notches are made in the form of shoes with special springs enveloping the knife contacts of the blocks. To provide for a reliable contact, the surfaces of the springs and the knife contacts are coated with a gold and nickel alloy. Supplied along with the terminal rack is a ST-450.4 alternating current regulator, which is installed separately from the rack.

The construction of an unattended amplifier station (NUP): An unattended amplifier station for a single quadded cable (an amplifier station of the PZS-2 type) consists of a cast iron box and two switching junction boxes (Figure 4.18). A brass box, which is hermetically sealed by soldering when it is made, is placed in the cast iron box. Located inside the brass box

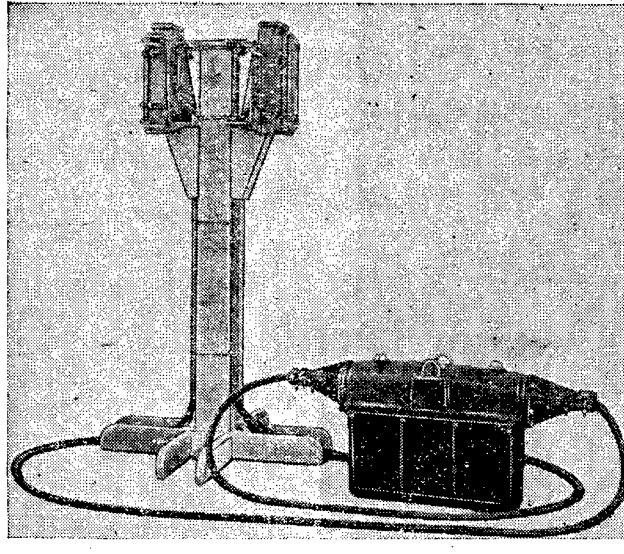

Figure 4.18. General view of the NUP for the KNK-6 equipment (PZS-2 intermediate station).

are four intermediate amplifiers, of which two are the main ones, and two are standbys, a block with auxiliary circuits and a humidity indicator, as well as a charge of a moisture drying agent. The intermediate amplifiers are similar to the amplifiers of the terminal equipment and are made using printed circuit boards.

A cover is provided for the upper part of the brass box which covers the access to the solder connections. Prior to installing the NUP on the line, the cover is unsoldered and all the necessary resoldering connections of the artificial line, the remote power circuits, etc. are made. In this case, the hermetic seal of the brass box is not disturbed.

After soldering the cover in place, the space between the [cast iron] box and the brass box is filled with potting compound (supplied along with the equipment), and the cast iron box is closed with a cover and buried directly in the ground.

The dimensions of the cast iron box are 540 x 1,160 x 254 mm, the weight along with the brass box and the amplifiers is 135 Kg. The surface of the box is coated with asphalt paint to protect it against corrosion.

The switching junction boxes with dimensions of 50 x 30 x 20 mm are placed on ferrocement extensions of the PR-1 type. The extensions are fabricated on site. Placed in the boxes are the break jacks for the transmission channels, which are necessary for making operational measurements, the inputs



and outputs for all four amplifiers, which permit switching the channel from defective amplifiers to good ones, as well as jacks for connecting the service communications set and the measurement of the insulation resistance of the humidity indicator. Additionally, protective devices consisting of gas filled R-350 dischargers and IR-0.2 spark dischargers are placed in the boxes. The box is closed with a hinged cover. Moisture impenetrability is assured by a rubber packing seal.

Each box is equipped with a packed-up section of single quadded VTSP cable 2.5 m long, which serves for making the connection to the line, and a packed section of four-quadded cable 6 m long with a lead jacket for making a connection to the underground part of the NUP.

The equipment makes it possible to organize communications with branching of the individual six-channel systems in two or three directions. Cable boxes, which are supplied along with the equipment, are installed at stations which are not equipped with input devices. Placed in the box are break jacks, protective devices (R-350 and IR-0.2 dischargers) and transformers for organizing a phantom circuit using an unmultiplied pair. In case of interference from long wave radio stations, a DR-120-K filter cover can be installed in the box. Where necessary, intermediate amplifiers can also be equipped with similar DP-120-Z filters. The cable box for station A with four six-channel systems is designed for branching the communications in three directions.

Measurement equipment: Attached to station A is a 12XJ035 generator and two level indicators, 12XN042 and 12XN036, while attached to station B is a 12XJ035 generator and a 12XN036 level indicator. The wideband 12XN036 level indicator is designed around transistors. The main technical data for the level indicators are given in Table 4.16.

TABLE 4.16. Technical Data for Level Meters

Characteristic Measurement	Unit of Measurement	12XN042		12XN036
		Wideband	Narrow Band (Passband $\pm 600$ Hz)	
Frequency range	KHz	0.3 - 550	10 - 550	0.03 - 300
Measurement limits	dB (Nep)	-60.8 to +21.7 (-7 to +2.5)	-87 to +21.7 (-10 to +2.5)	-60.8 to +28.7 (-7 to +3.3)
Input impedance	Ohms	Balanced, 75, 150, 600, and >5,000		Balanced and un- balanced, 150, 600, and > 20,000
Power supply		Mains, 120/220 volts, 50 Hz, 100 VA		Battery, 6 to 9.5 volts, 4.5 mA
Weight	Kg	16		4

The 12XJ035 generator operates in a frequency range of 0.3 - 550 KHz. The output level can be adjusted within limits of +17 to -67 dB (+1.5 to -7.7 Nep) with an internal impedance of 75, 150 or 600 ohms. The instrument is powered from the AC mains, and the weight of the instrument is 17.6 Kg.

The KNK-60 equipment was supplied prior to 1966.

#### 4.10. The KNK-6T Equipment

The basic technical data for the KNK-6T equipment<sup>1</sup> are the same as for the KNK-6S equipment.

The NUP amplifiers are equipped with an ARU [automatic gain control] based on the ground temperature which partially compensates for the seasonal changes in the cable attenuation. This has made it possible to increase the maximum number of NUP's between terminal stations up to six and bring the maximum communications range via a VTSP cable (MRTU 16.505.010-64), as well as a KSPP 1 x 4 x 1.2 cable, up to 112 Km with seven sections of 16 Km each. A spacing of up to 18 Km is permitted between terminal stations, and when using one NUP, up to 17 x 2 = 34 Km. For KSPP cable 1 x 4 x 0.9, the length of a section is 15 Km, while the overall communications range is 105 Km.

Up to three NUP's can be powered from one terminal station remotely, and the remote power supply current is reduced to 15 mA. Three intermediate equipment complexes are placed in a NUP, of which the third complex is the standby and can be switched in by means of handles in the switching junction box in place of either of the two main complexes.

A provision is made for the capability of remotely determining the number of damaged NUP from the terminal station. For this purpose, each intermediate amplifier is equipped with an oscillator designed for a frequency set for each of them. The oscillators at the NUP's are switched on from the terminal station by means of reversing the polarity of the remote power supply circuit. The signals from the different intermediate amplifiers are fed to the terminal station on different telephone channels. A damaged amplifier is determined by listening for the monitor signals in the channels.

The signal channel receiver has been refined; the transmit level via the signal channel has been reduced to -6.0 dB (-0.7 Nep). A hermetically sealed reed type relay has been installed at the receiver output. The pulse distortion does not exceed  $\pm 6$  msec when the receive level varies by  $\pm 3.4$  dB ( $\pm 0.4$  Nep).

The equipment is powered from the AC mains at 50 Hz and a voltage of 220 volts  $\pm 3\%$ . Attached to the equipment is a ST-250.4 power supply regulator which permits extending the permissible fluctuations in the mains to +10 to -15%.

<sup>1</sup> Produced since 1967.

Also supplied with the terminal station is a separate NTT-60 emergency power supply complex. The complex provides for automatically switching the equipment power supply over from the main source to the standby in case the primary source voltage is lost, as well as automatically switching it back when the main voltage appears. A -60 volt station battery can be used as the main power supply, while the AC mains can be used as the standby, or vice-versa. It is also possible to power the equipment through the NTT-60 complex from the -60 volt battery alone.

The power consumed by a rack set up with two or four six-channel systems, when powered directly from the mains, does not exceed 90 watts (120 VA) and when powered through the ST-250.4 regulator, it does not exceed 150 watts (275 VA).

A provision is made for the capability of organizing a broadcast channel via a phantom circuit in a passband of 100 - 6,000 Hz in place of the service communications channel.

Main equipment of from one up to four six-channel stations is housed in ST4A and ST4B terminal racks, and in ST2A and ST2B racks, the equipment for one to two stations. The list of supplemental equipment and measurement instruments which are supplied along with the terminal racks is given in Table 4.17.

TABLE 4.17. Supplemental Equipment and Measurement Instruments

Наименование Designation	ST4A	ST4B	ST2A	ST2B
1. Аппарат служебной связи SLS.	I	I	I	I
2. Кабельная коробка	I (KAS 4A)	I (KAS 4B)	I (KAS 2A)	I (KAS 2B)
3. Измерительный генератор 12XJ035	I	I	I	I
4. Указатель уровня 12XN042A	I	—	I	—
5. Указатель уровня 12XN036	I	I	I	I
6. Псофометр 12XN031	I	—	I	—
7. Стабилизатор ST250.4	I	I	I	I
8. Комплект питания NTT.60	I	I	I	I

Key: 1. SLS service communications set; 2. Cable box; 3. 12XJ035 measurement generator; 4. 12XN042A level meter; 5. 12XN036 level indicator; 6. 12XN031 noise meter; 7. ST250.4 regulator; 8. NTT.60 power supply complex.

When ordering, the cable type for the VAJ (with the capability of automatic through working) or VIJ (only for terminal mode operation) differential systems is specified, with which the terminal six-channel SKS6 single terminal sets should be equipped. In case this specification is missing, the equipment is supplied with the VAJ differential systems.

The PZS2TR (unattended intermediate station) intermediate amplifier station with ARU is supplied along with two switching junction boxes and connecting cables with a set of accessories for installing it and also spare parts. For lines with one to three NUP's, one NPZ remote power supply block is ordered, while two such blocks are ordered for lines with a greater number of NUP's.

A supplemental DOS switching junction box is supplied on special order, which is intended for connecting broadcast equipment to the phantom circuit of a single quadded cable; also supplied are six channel SKS6 single terminal sets as expansion equipment for installation at previously supplied terminal stations using KNK-6T equipment, as well as additional service communications sets, differential systems, regulators and switching junction boxes.

The KNK-6Sm equipment is a transitional type between the KNK-6S and KNK-T. This equipment is distinguished from the KNK-6S equipment through the use of an unattended amplifier station with ARU based on the temperature of the ground by the NTT 60 emergency power supply complex, as well as VAJ type differential systems, designed for the possibility of making through call connections without increasing the channel attenuation. It was supplied in 1966.

#### 4.11. The KNK-12 Equipment

Function and basic characteristics: The KNK-12 equipment is intended for multiplexing single quadded KSPP and VTSP cables; each pair is multiplexed with 12 channels in a frequency range up to 108 KHz; when multiplexing two pairs on a single quadded cable, 24 channels can be organized.

Included in the equipment complement are terminal and intermediate unattended remotely powered amplifier stations. Up to six NUP's can be inserted between the terminal stations. The maximum length of an amplified section when using KSPP 1 x 4 x 1.2 and VTSP 1 x 4 x 1.2 cables is 16 Km, and for KSPP 1 x 4 x 0.9 cable, 15 Km, while the maximum communications length reaches 105 and 112 Km. The minimum length of an amplified section is 1/3 of its maximum length.

The total design noise power in the telephone channel at the maximum communications range is 2,000 picowatts, of which 1,000 picowatts is due to thermal and nonlinear noise in the terminal and intermediate equipment, and 1,000 picowatts to noise in the line.

The lower group of channels is transmitted in the direction from station A to station B in a frequency range of 6 - 54 KHz, while the upper group of channels is transmitted in the opposite direction in a range of 60 - 108 KHz. The transmit level (with respect to power) is -3 dB, and the minimum receive level at a frequency of 108 KHz is 52.1 dB. In the AB and BA directions, the ARU control signals at 54 and 60 KHz respectively are transmitted on the line at levels of 15 dB below the measurement level.

The terminal equipment is based on the standard 12 channel block with electro-mechanical channel filters. The frequency conversion configuration and the

and the line spectrum are shown in Figure 4.19. All the carriers and control frequencies are derived from a thermostatically controlled crystal oscillator at 100 Hz with a relative frequency instability of no more than  $1 \cdot 10^{-6}$  over the course of a month. The amplitude instability of the control signals over a month does not exceed  $\pm 0.2$  dB (0.03 Nep).

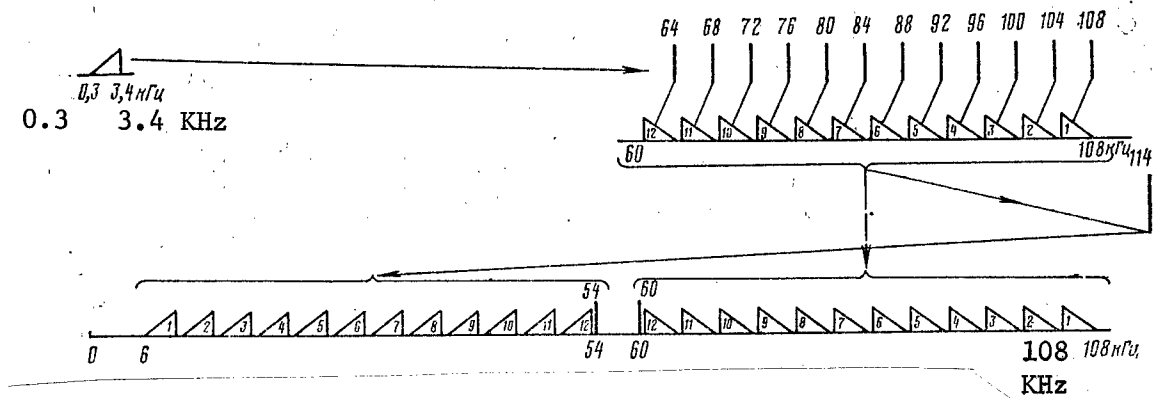

Figure 4.19. The frequency conversion and line spectrum of KNK-12 equipment.

A complete complex of equipment for one or two 12-channel systems including the electrical power supply unit, differential systems, and where needed, companders, are housed in the terminal rack with dimensions of 2,120 x 600 x 225 mm. The construction of the equipment is modular. The weight of an equipped rack does not exceed 200 Kg. The terminal equipment is intended for operation in rooms with an ambient temperature of 10 - 40° C and a relative air humidity of 45 - 75%; at temperatures of up to 25° C, an increase in the humidity up to 85% is permitted.

#### Channel characteristics:

The telephone channels are designed for the effective transmission of signals in a passband of 300 - 3,400 Hz

Amplitude-frequency distortion with respect to the attenuation at  $f = 800$  Hz:

Excess response, no greater than	3 dB (0.35 Nep) [300 - 400 Hz and 3,000 - 3,400 Hz]
	1.8 dB (0.2 Nep) [400 - 600 Hz and 2,400 - 3,000 Hz]
	0.9 dB (0.1 Nep) [600 - 2,400 Hz]
Response low, by no more than	0.9 dB (0.1 Nep) [300 - 3,400 Hz]

Nonlinear distortion factor, no more than:

Total	1.5%
Third harmonic	1%

Amplitude characteristic with the amplitude limiters switched in Linear within  $\pm 0.3$  dB (0.035 Nep) when the input level increases 3.4 dB (0.4 Nep) above the measurement level

Internal noise voltage of the terminal equipment at the point with a zero measurement level, no more than 0.4 millivolts, psophometric

Isolation against audible crossovers in the terminal equipment, no less than:

Between the channels of one system	69.5 dB (8.0 Nep)
Between the channels of different systems	73.8 dB (8.4 Nep)

Isolation between the transmission directions of one channel, no less than 56.5 dB (6.5 Nep)

The telephone channels are designed for secondary multiplexing. Any of the channels can be set aside for facsimile transmission. The characteristics of the channels, with the exception of those which occupy the extreme end positions in each of the transmission directions, are designed for the capability of transmitting data and multichannel telegraphy signals. By combining two telephone channels, it is possible to organize a Class II broadcast channel in accordance with GOST 11515-65. In the case where cable lines are multiplexed which are subject to significant noise, the telephone channels can be equipped with companders, which are installed in the terminal station rack.

Each telephone channel is equipped with its own isolated signal channel. The signal channel operates at a frequency of 3,825 Hz at a level 20 dB (2.3 Nep) below the measurement level. A provision is made for the ability to transmit signals via the isolated channel when conversation or other information is being passed via the given telephone channel. By means of continuous signal transmission on the isolated channels, it is also possible to realized constant monitoring of the proper operation of the free (unoccupied) telephone channels. The signal channel is terminated with a hermetically sealed reed type relay which forwards the transmitted pulses to the RSL [connector relay]. The distortion of the transmitted pulses when the residual attenuation fluctuates within limits of  $\pm 5.2$  dB ( $\pm 0.6$  Nep) does not exceed  $\pm 6$  msec.

Placed in the NUP is the intermediate equipment for two 12 channel systems. The amplifiers are equipped with ARU based on the temperature of the ground, which maintains a constant output level. The crosstalk attenuation between the two equipment complexes housed in one NUP exceeds 78.2 dB (9 Nep). The level of the internal thermal noise of the amplifier, referenced to its input, amounts to about -130.3 dB (15 Nep) in the 104 - 108 KHz passband. The suppression of second and third harmonic nonlinearity is no less than 78.2 and 87 dB respectively (9 and 10 Nep). Half of the NUP structure is below

ground, with the ability to gain access to the equipment without engaging in digging operations. The structure provides for normal equipment operation when the temperature of the outside air changes within limits of  $-40$  to  $+50^{\circ}$  C, and at a humidity of up to 98% at  $40^{\circ}$  C.

The return loss factor from the input impedance of the terminal and intermediate equipment with respect to the characteristic impedance of the cable satisfies the following condition in the working passbands:

$$0.25 \geq k \leq 0.15\sqrt{108/f},$$

where  $f$  is the given frequency in KHz.

The single frequency flat-slope ARU of terminal stations is designed for eliminating inaccuracies in the operation of ground temperature type ARU's, which accumulate from NUP to another. When the receive level of the control signal changes at the input of the terminal station within limits of  $\pm 3.4$  dB ( $\pm 0.4$  Nep), its level at the output of the group receive equipment is maintained constant within  $\pm 0.43$  dB ( $\pm 0.04$  Nep). When the receive level of the control signal deviates by more than  $\pm 3.4$  dB (0.4 Nep), the signaling system actuates indicating an irregularity on the group channel. A provision is made for the capability of switching out the ARU and go over to manual control, as well as for the ability to automatically block the telephone channels in the case where the control signal level decreases by 5.2 dB (0.6 Nep).

The terminal equipment is powered from the AC mains at  $50 \pm 2$  Hz and 220 volts ( $-15\%$ ,  $+10\%$ ); in case of an impermissible reduction or loss in the AC mains voltage, the equipment is automatically switched over to standby power from the ATS station battery at -60 volts ( $-10\%$ ,  $+20\%$ ); when the mains voltage appears, it is switched back in. A fully outfitted terminal rack uses no more than 160 VA when powered from the mains, and when powered from a battery, no more than 2.4 amps.

A NUP is powered remotely using DC via the phantom circuit of a single-quadded cable. Up to three NUP's can be powered from one terminal station. The remote power supply current is 40 mA, and the remote power supply voltage does not exceed 200 volts. An increase in the remote power supply current of 50% is noted by the signaling system at the terminal station supplying the power.

Service communications between terminal stations and NUP's is realized, just as in the KNK-6S equipment, via a phantom circuit using telephone sets with loudspeakers. Just as in the KNK-6T equipment, a provision is made for remotely determining the number of a damaged NUP from the terminal station. The line protection devices are included in the terminal and intermediate equipment complement.

#### 4.12. The IKM-12M Pulse Code Modulation Equipment

The equipment complex provides for multiplexing KSPP  $1 \times 4 \times 0.9$  or KSPP  $1 \times 4 \times 1.2$  cable with 12 telephone channels in a single sideband single cable system

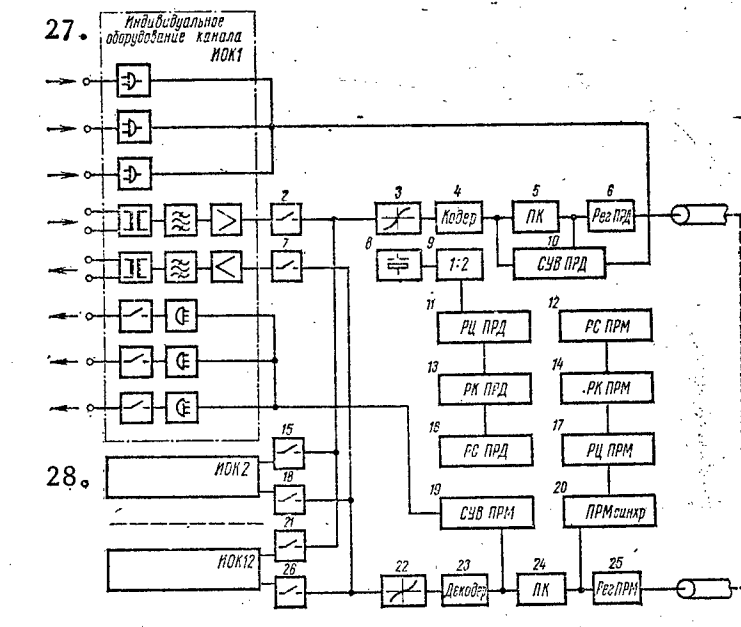

Figure 4.20. Schematic of the IKM-12M equipment.

Key: 4. Coder; 5. PK, code converter; 6. Reg PRD, transmit repeater; 10. SUV PRD, ATC control and interaction signals, transmit; 11. RTs PRD, Transmit digital distributor; 12. RS PRM, Receive signal distributor; 13. RK PRD, Transmit, channel distributor; 14. RK PRM, Receive channel distributor; 16. RS PRD, Transmit signal distributor; 17. RTs PRM, Receive digital distributor; 19. SUV PRM, ATS interaction and control signals, receive; 20. PRM sinkhr, synchronization receiver; 23. Decoder; 24. PK, receive code converter; 25. Reg PRM, receive repeater; 27. Individual channel equipment, IOK 1; 28. IOK 2, individual channel equipment block 2.

with a maximum spacing between the unattended remotely powered repeaters of up to 7.2 Km or 7.3 Km respectively. The communications range when remotely powered from both ends is up to 50 Km. The maximum number of intermediate stations which can be supplied with remote power from two terminal stations is seven for KSPP 1x4x0.9 cable, and eight for KSPP 1x4x1.2 cable.

The complex permits the organization of two telegraph channels without occupying the telephone channels.

A second class broadcast channel with three two-way remote control channels and a return monitor channel can be organized instead of two telephone channels.



The telephone channel equipment can be multiplexed with all types of secondary multiplex signals.

Shown in Figure 4.20 is a simplified schematic of the IKM-12M equipment. Shown in Figure 4.21 is a diagram of the time relationships for the equipment.

The gating frequency of the telephone signals is 8 KHz, which corresponds to the 125 microsecond period of the gating pulses. The time interval between two gating pulses for one channel is termed a cycle. A cycle is broken down into 12 channel intervals (Figure 4.21). Each channel interval contains seven bits, intended for the coding and transmission of telephone messages. Between the 3 - 4, 6 - 7, 9 - 10 and 12 - 1 channel intervals, the free timing positions are intended for cyclical and hypercyclical synchronization, and control and interaction signals for the ATS and telegraph.

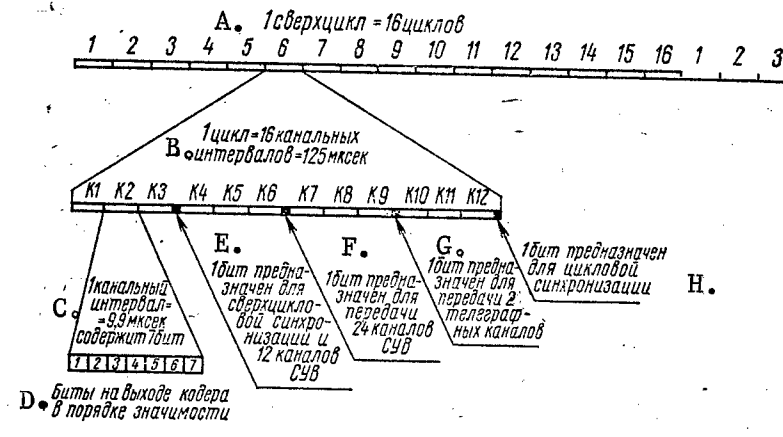

Figure 4.21. Diagram of the time relationships

Key: A. One hypercycle = 16 cycles; B. One cycle = 16 channel intervals = 125 microseconds; C. One channel interval = 9.9 microseconds, contains 7 bits; D. Bits at the coder output in order of significance; E. One bit intended for hypercycle synchronization and 12 channels of SUV [ATS interaction and control signals]; F. One bit intended for transmitting 24 channels of SUV; G. One bit intended for transmitting two telegraph channels; H. One bit intended for cyclical synchronization.

The telephone channels and ATS interaction and control signals (SUV) are fed to the input of the individual channel equipment (IOK) block (see Figure 4.20), which can be employed in a four-wire or a two-wire circuit configuration by means of setting the corresponding jumpers on the circuit board. The input and output levels are set by means of attenuator pads located in the block. The IOK blocks contain a transformer, differential system, 300 - 3,400 filter and an amplifier.

Gating circuits 2, 15 and 21 are intended for sampling the telephone signals and converting them to a time quantized signal using pulse amplitude modulation.

The gating circuits are controlled on command from the channel distributor, 11. The pulse amplitude modulated signal combined at the outputs of the transmission gating circuits is fed through a fast response compressor, 3, with  $\mu = 30$ , which is intended for creating the requisite signal to noise ratio for the quantization, to the input of the coder where it is quantized with respect to amplitude and converted to a seven valued code combination.

The SUV PRD block [ATS interaction and control signal transmission block], 10, combines the signals from the individual equipment of the signal channels, shapes the pulse train for the cyclical and hypercyclical synchronization and writes them into the group signal in the code converter block, 5.

The transmit repeater shapes a single polarity pulse width equal to the timing interval of 1.4 microseconds, a pulse signal suitable for transmission on the line.

The line signal is restored in amplitude, shape and timewise position in the receive repeater, 25, (just as in each line repeater) and is fed to the inputs of the receive code converter, 24, and the synchronization receiver, 20. The synchronization receiver, having separated out the synchronized pulse train in the composite line signal, establishes the necessary phase for the receiving generator equipment. The digital binary signal is fed from the output of the code converter to the decoder where it is converted to a pulse amplitude modulated signal.

Channel distributor 14, by means of receive gating circuits 7, 18 and 26, controls the distribution of the pulse amplitude modulated signal over the corresponding blocks of the individual channel equipment. The SUV receive block, 19, distributes the SUV information to the corresponding channels on the instruction of the receive signal distributor, 12. The equipment for the individual SUV receive channels is located in each IOK block [individual channel equipment block] and is terminated in an electronic switch.

The primary frequency of 1,408 KHz is generated by crystal oscillator 8 and is used for the coder operation. The repetition rate of the digit symbols is derived at the output of the 1:2 divider (9). Digital distributor 11 divides the 704 KHz frequency down to the frequency of the digit symbols and controls the operation of the digit circuits of the coder. The channel pulses, controlling the operation of the gating circuits, are produced by channel distributor 13. The hypercycle intended for SUV transmission is formed by means of dividing the frequency of the channel distributor by 16 in signal distributor (RS) 16.

The 704 KHz repetition rate of the digit symbols in the receive station is formed from the received pulse sequence in the receive repeater and controls the system of dividers, 7, 14 and 12, through the cyclical synchronization receiver.

The following equipment must be used to organize communications for 12 telephone channels:

- Two IKM-12M terminal stations, each including: a 12 channel block, a block of terminal repeater equipment, an intercom unit;
- Intermediate stations in the number necessary for the given type of cable and route length, each including: two repeater line amplifiers, two phantom lines, and NUP's.

The given equipment permits connection an ATS of any type using standard RSL's [connector relays]. When it is necessary to organize two telegraph channels operating in dual polarity or single polarity modes with a call-up instrument, one must provide for a two channel telegraph unit (DTU). The design of the matching devices, the SU-IKM's (used in place of the existing RSL's), makes it possible to house them in one cabinet with the terminal station, the IKM-12M (the SU [matching device] submodule). When using SU-IKM's, two (for city ATS's) or three (for rural ATS's) signal channels are used for each telephone channel.

When it is necessary to organize a broadcast channel, a broadcast channel individual equipment unit should be additionally order (two units). The broadcast channel unit is installed in the 12-channel block in place of the individual equipment for the two telephone channels.

#### Channel characteristics:

The variation in the residual attenuation in the 300 - 3,400 KHz passband as a function of the frequency, with respect to its value at 800 Hz	[Meets] MKKT [International Consultative Committee on Telephony] [standards] in any channel
Total nonlinear distortion at 800 Hz	No greater than 3%
Average value of the psophometric noise power at the zero measurement level point during the busy hour, less than	900 picowatts
Isolation against audible crossovers between channels	No less than 60 dB for 100% of the channels
Residual attenuation instability during operation over one month, no more than	± 1 dB
Ratio of the signal power to the psophometric quantization noise power, greater than	26 dB (3 Nep)
Distortion of pulses transmitted via the signal channel, no greater than	± 4 msec
Average synchronization lock-in time, no greater than	11 msec
Equipment power supply	From the ATS power sources at a nominal voltage of 54 - 72 volts
Power consumed by the equipment, no more than	50 watts when remotely powered

Remote power supply voltage	200 volts
Remote power supply current, up to	100 mA.

The IKM-12M terminal station is housed in a cabinet with dimensions of 2,150 x 600 x 225 mm. The maximum number of stations in one cabinet is three (without the SU-IKM block and DTU).

The RSL connection of the ATS to the terminal station is realized via a multi-pair station cable. The cable is brought in through the top of the cabinet and unsoldered at the input connectors of the 12-channel block. Because of the presence of the connectors joining the station and cabinet blocks, one can easily replace a faulty block.

An intermediate station, a PS, is designed so that four line repeater amplifiers can be installed in it for operation via two cables of two systems, and is buried in the ground at a depth of around 900 mm in a vertical position. replacing repeaters in the intermediate station is accomplished through the NUP cover, extending 500 m [sic] above the surface of the ground. The connection of cables to the PS is made by means of assembly cables included in the intermediate station complex.

The weight of a terminal station when the three IKM-12M systems are installed is no more than 250 Kg, and the intermediate station weighs no more than 10 Kg. The IKM-12M intermediate station is 1,580 mm high and has a diameter of 500 mm.

The first batches of IKM-12M equipment were supplied with audio termination complexes, designed for terminal mode operation of the channels with a residual attenuation of 7 dB (0.8 Nep) and 3.4 dB (0.4 Nep), and with the capability of automatically changing over to a four-wire through working mode (a type II KNO [low frequency termination complex]). Since 1973, the equipment has also been supplied with audio termination complexes designed for terminal mode operation with the residual attenuation magnitudes indicated above, but with the ability to automatically switch over to a two-wire through working mode (type I KNO). The type of KNO is indicated when ordering the equipment.

#### 4.13. Amplifiers for Rural Telephone Communications

##### Function and Main Characteristics

UMT and UMS bridging amplifiers can be used on rural telephone communications networks. UMS amplifiers differ from similar amplifiers used on GTS's [city telephone exchanges] in that:

- The limits for the change in the two terminal networks are expanded;
- Compensation is provided on interexchange connections for the influence of the DTN type line transformer inductance;
- MP26B high voltage transistors are used instead of MP40A (P14) transistors.

UMS amplifiers are intended for reducing the circuit attenuation of junction lines which are not multiplexed and not coil loaded, and use TPP cables in a passband of 0.3 - 3.4 KHz. In the absence of multiplex equipment, the amplifiers can be used on junction lines which use VTSP and KSPV type cables, as well as on steel open wire line communications circuits with conductor diameters of 3 - 4 mm. Additionally, UMS's can be employed on lines using TPP, T and TZ type cables, and in certain cases, on mixed circuits consisting of sections of a cable circuit and an open wire steel circuit.

The gain of the amplifier depends on the attenuation of the telephone circuit and can be set within limits 3.4 to 8.5 dB (0.4 to 1.0 Nep) at a frequency of 800 Hz when it is switched into a cable circuit, and within limits of 3.4 to 7.38 dB (0.4 - 0.85 Nep) when it is hooked into the steel circuits of open wire lines.

The amplifiers provide for the equalization of the amplitude-frequency response of cable circuits within a passband of 0.3 - 3.4 KHz, and the steel circuits of open wire lines within a passband of 0.3 - 2.4 KHz.

The residual attenuation of telephone circuits with the amplifiers connected satisfies Part XVI.1.10 of "Vremennyye normy na kanaly obshchegosudarstvennoy avtomaticheskoy kommutiruyemoy telefonnoy seti" ["Provisional Standards for the Channels of the Overall State Automatically Switched Telephone Network"], approved 26 November, 1968, by the Interdepartmental Coordinating Committee of the USSR Communications Ministry.

The amplifiers pass the interaction signals for the ATS's of all systems, transmitted using both DC and 50 Hz AC, as well as inductive dial pulses at up to 120 volts.

The level of the noise introduced by the amplifier into the line does not exceed 0.3 millivolts.

The power for the amplifiers is derived from exchange DC sources at 24 and 60 volts with voltage fluctuations within limits of -10 to +30%, in which case the gain in the working frequency range remains practically unchanged. The current consumption per amplifier is 30 mA.

The amplifiers should be installed in buildings with an air temperature of from +10 to +45° C, and a relative humidity from 45 to 85%.

#### Amplifier Circuitry and Construction

The two-way bridging amplifier takes the form of an active four terminal network, designed in a bridge T configuration. The amplifier schematic is shown in Figure 4.22. Transformer  $Tr_1$  provides for setting up the bridge circuit and the connection of the amplifier to the line. The four terminal network contains two active elements: series and parallel converters ( $P_1$  and  $P_2$ ) of passive two-pole negative impedance networks. Connecting this active four-terminal network to a telephone circuit decreases the attenuation of the

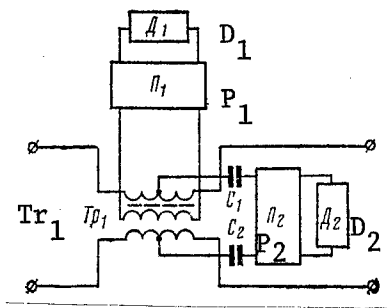

Figure 4.22. Structural schematic of a bridging amplifier.

The basic circuit of a bridging amplifier is shown in Figure 4.23. The series  $P_1$  and parallel  $P_2$  converters take the form of push-pull amplifiers with positive feedback, designed around transistors  $T_1 - T_4$  of the MP26B in a common base configuration. In converter  $P_1$ , the positive feedback is produced using transformer  $Tr_2$ . Additionally, power is fed through this transformer to the collectors of transistors  $T_1$  and  $T_2$ . Resistors  $R_1, R_2$  and  $R_3$  establish the requisite operational mode and provide for temperature sta-

latter by the amount of the negative attenuation of the four terminal network. To preclude power losses occasioned by reflection at the junction of the circuit and the four terminal network, its characteristic impedance should be equal to the input impedance of the telephone circuit. The parameters of telephone circuits, depending on the type and extent of the circuit, vary in rather large range, and for this reason, in each individual case when using an amplifier, it is necessary to align it directly when connecting it into the telephone circuit.

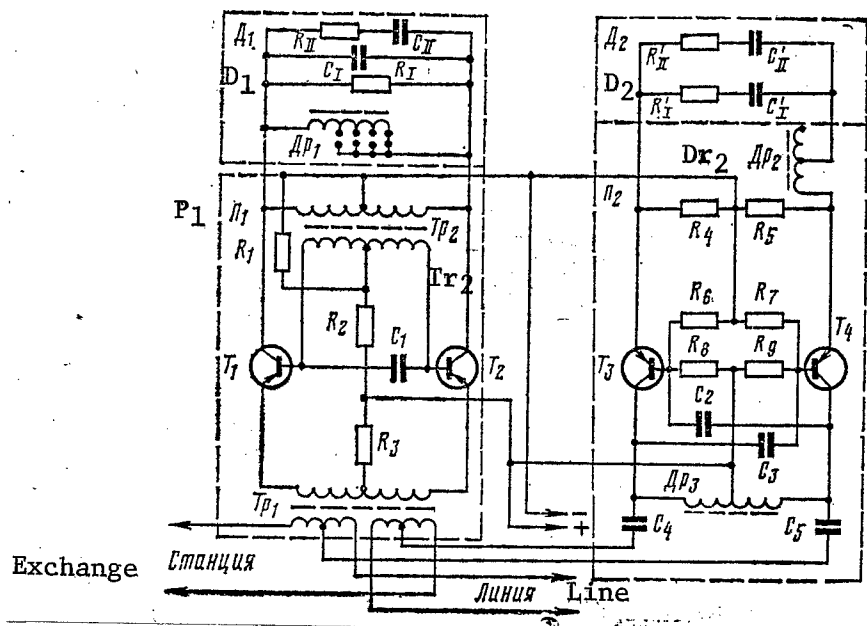

Figure 4.23. Basic schematic of a bridging amplifier.

bilization of the transistors. Capacitor  $C_1$ , shunting the feedback winding of transformer  $Tr_2$ , assures amplifier stability at frequencies of 10 - 15 KHz. To increase the stability at frequencies on the order of 100 - 150 Hz, the

inductance of the winding of transformer  $Tr_2$ , which is connected to the collector of the transistors, should be somewhat less than the inductance of the winding of transformer  $Tr_1$ , which is connected to the emitters of the transistors. In converter  $P_2$ , positive feedback is provided by capacitors  $C_2$  and  $C_3$  and resistors  $R_6 - R_9$ . Resistors  $R_4 - R_9$  provide for the operational mode and temperature stabilization of the transistors. Choke  $Dr_2$ , which is connected in series with two terminal network  $D_2$ , provides for amplifier stability at frequencies above 15 KHz.

The working mode for the transistors is  $V_{ce} = 12$  volts and  $I_c = 5$  mA. The current consumption for one amplifier is 30 mA. The temperature stability

coefficient is 2. The amplifiers are made in three structural variants: the UMS-1 (Figure 4.24), the UMS-3 (Figure 4.25) and the UMS-5 (Figure 4.26), which differ in the number of amplifiers in the block. All three variants are designed around the same basic circuit. To improve the quality and decrease the size, printed circuit boards are used in the UMS-5 amplifiers.

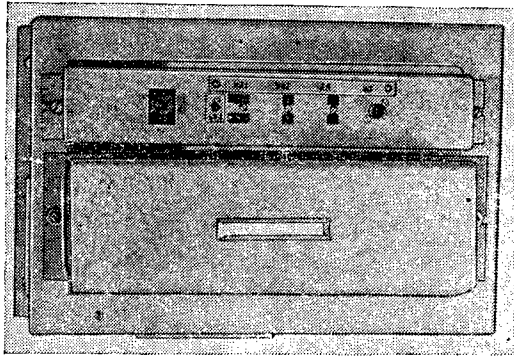

Figure 4.24. The structural design of the UMS-1 amplifier.

The UMS-1 and UMS-3 amplifiers contain plug-in boards which are fastened to the steel chassis.

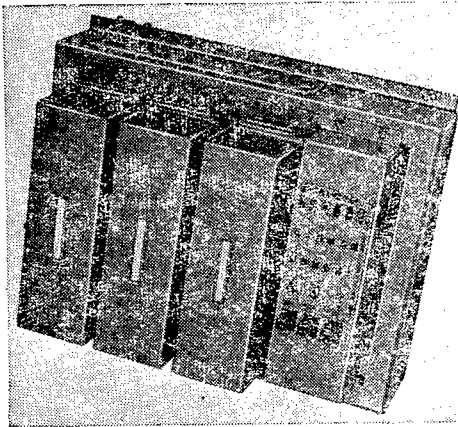

Figure 4.25. The structural design of the UMS-3 amplifier.

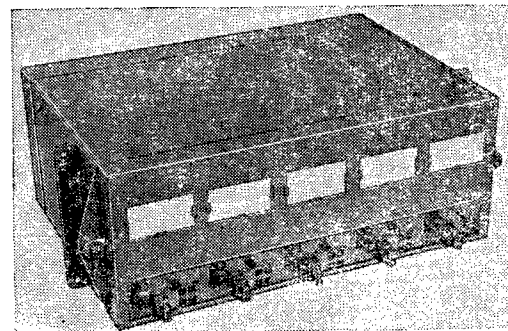

Figure 4.26. The structural design of the UMS-5 amplifier.

Placed in the upper part of the chassis behind the board is a socket with pins, intended for bringing in the line conductors and connecting the power supply and signaling lines, while in the lower part, there is a power supply and signaling panel on which the individual fuses, test jacks and push button switches are placed. A general view of a UMS-1 and UMS-3 amplifier plug-in

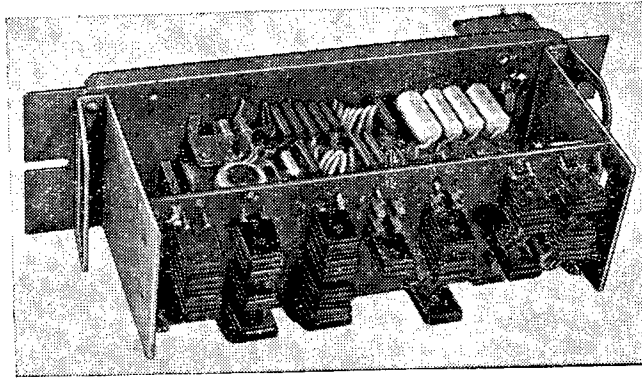

Figure 4.27. General view of the UMS-1 and UMS-3 amplifier plug-in board.

board is shown in Figure 4.27. Transformers  $Tr_1$  and  $Tr_2$ , choke  $Dr_3$  and two getinax [paper/bakelite plastic] panels are fastened to the steel mounting plate. Located on one panel are the components of converters  $P_1$  and  $P_2$ , and on the other, the components of the two terminal networks. Located on the

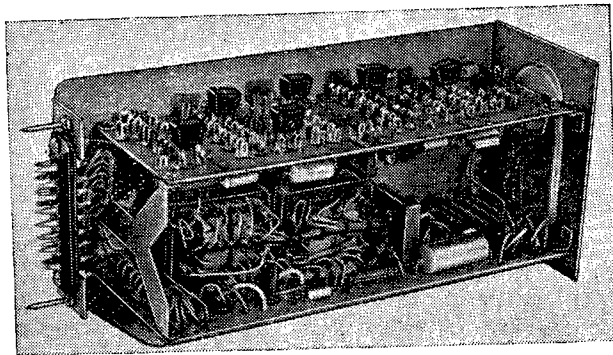

Figure 4.28. General view of the UMS-5 amplifier plug-in board.

face of the panel for the two terminal are strips, and on the reverse side, a set of resistors, capacitors and choke  $Dr_1$ . The requisite magnitudes, capacitances, and inductance are connected into the circuit by means of special short circuiting two-pin plugs, during the process of aligning the amplifier, and the plugs are replaced with permanent jumpers after alignment. The electrical circuit of the plug-in board of the amplifier is connected to the block circuitry by a plug-in connector.

The dimensions of the UMS-1: 380 mm wide, 223 mm high and 205 mm deep. The weight is 6.5 Kg.

The dimensions of the UMS-3: 980 mm wide, 455 mm high and 205 mm deep. The weight is 13.5 Kg.

The UMS-5 amplifier blocks are designed for installation in SN-5 racks or ones similar to them.

The UMS-5 amplifier block takes the form of a housing in which five plug-in amplifiers are placed. Located in the lower part of the housing is the power supply and signal panel, on which the individual fuses, test jacks and push button switches are located. Mounted on the rear panel of the housing is a block with pins intended for bringing in the line conductors, the power



supply and signaling lines, and the power supply jack. The input terminal block and the installation leads are covered with a removable cap. Plug connector sockets, which provide for electrically connecting the amplifier circuit to the block circuitry are mounted inset in the housing. An overall view of the UMS-5 amplifier plug-in board is shown in Figure 4.28. Secured to the UMS-5 amplifier plug-in board are two printed circuits and the male connector of the plug connector. Located on one printed circuit board are the components for converters P<sub>1</sub> and P<sub>2</sub>, and on the other, the components of the two terminal networks D<sub>1</sub> and D<sub>2</sub>. The amplifier boards are inserted in the chassis and closed in with a cover which is secured with screws of the type which do not fall out of the hole when loosened. Labels are applied to the cover for recording the circuit data and the gain of the amplifiers.

The UMS-5 amplifier dimensions: 457 mm wide, 160 mm high and 290 mm deep. The weight is 13.75 Kg.

#### Alignment Procedure

The alignment of the amplifiers is composed of two basic steps:

- Determining the gain;
- Determining the magnitudes of the components of the two terminal networks, D<sub>1</sub> and D<sub>2</sub>, which provide for the requisite amount of gain and matching the characteristic impedance of the amplifier to the input impedance of the telephone circuit over the entire working frequency range.

The gain of a bridging amplifier is determined by the conditions for stable operation, and depends on the attenuation of the telephone circuit and the level of matching of the characteristic impedance of the amplifier to the input impedance of the telephone circuit within the limits of the working frequency passband.

In connection with the fact that besides the demands on the stability of the amplifier, a requirement is also made for the correction of the amplitude-frequency distortion of the telephone circuit, the best shape of the frequency response for the gain will obviously be that which, in the working frequency range, corresponds to the shape of the frequency response characteristic for the circuit attenuation, i.e. the following relationships will be observed:

When the amplifier is inserted in cable circuits:

$$\frac{S_{3,0}}{S_{0,8}} = \frac{a_{3,0}}{a_{0,8}}$$

When the amplifier is inserted open wire line steel circuits:

$$\frac{S_{2,4}}{S_{0,8}} = \frac{a_{2,4}}{a_{0,8}}$$

where S<sub>3,0</sub>, S<sub>2,4</sub>, and S<sub>0,8</sub> are the gains of the amplifier at frequencies of 3.0, 2.4 and 0.8 KHz;  
 a<sub>3,0</sub>, a<sub>2,4</sub>, and a<sub>0,8</sub> are the attenuations of the telephone circuits at frequencies of 3.0, 2.4 and 0.8 KHz.

The gain should fall off outside the working frequency range.

This shape of the amplitude-frequency response of the amplifier gain assures the following:

- The most favorable stability conditions, both within and outside of the working frequency range;
- The greatest amplifier efficiency at frequencies which determine the loudness and intelligibility of the speech amplifier;
- Satisfactory equalization of the amplitude-frequency distortion of the telephone circuit.

The amount of permissible amplifier gain is determined at the upper frequency of the working spectrum (3 KHz when the amplifier is connected into cable circuits, and 2.4 KHz when connected into open wire circuits) and is found from the expression:

$$S = \frac{1}{2} \ln \frac{1}{1 - 2a + p},$$

where  $p$  is the mismatch factor for the characteristic impedance of the amplifier and input impedance of the circuit.

The magnitude of the mismatch factor  $p$  is defined as 3% for cable circuits and 3.5% for steel open wire circuits. The quantity adopted for registering the stability assures long term operation of the amplifiers without needing alignment.

To simplify the alignment process, a calculation of the permissible gains is carried out as a function of the attenuation for different types of circuits. The results of the calculation are set forth in tables, which are set forth in tables, which are placed in the instructions for aligning the amplifiers.

The sizes of the components of the two terminal networks,  $D_1$  and  $D_2$ , can be found during the alignment process by means of trial and error. Since the number of variable elements in the two terminal networks is large, the order of amplifier alignment is of considerable importance.

For the purpose of facilitating the alignment, the sizes of the components of two terminal network  $D_1$  of the series converter are determined by calculation as a function of the gain and type of line.

The calculations have been performed for the following types of lines: TPP-0.4, TPP-0.5, TPP-0.7, KSPP(KSPV)-0.9, VTSP-1.2 and steel open wire line circuits with conductor diameters of three and four mm with cable feed-ins made using T and TZ type cables with copper cores having a diameter of 0.4 - 1.2 mm for a cable feed-in length of up to 1 Km. The results of the calculations are given in Tables placed in the alignment instructions.

The quantities for the two terminal network of the parallel converter are selected when aligning the amplifier. The amplifier alignment is realized

by matching the characteristic impedance of the amplifier to the input impedance of the circuit at frequencies of 0.8, 2.4 and 3.0 KHz, when setting the amplifier up on steel circuits, and at frequencies of 0.8, 2.0 and 2.4 KHz setting it up on steel open wire circuits, which is achieved by varying the quantities  $R_1$ ,  $C_1$  and  $R_1$  [sic] of the two terminal network of parallel converter  $D_2$ .

The final step in the alignment is measuring the amplitude-frequency response of the amplifier gain and checking its stability. A detailed sequence for the alignment of the amplifiers is set forth in the alignment instructions.

A specially developed portable PKUS device is used for the amplifier alignment process.

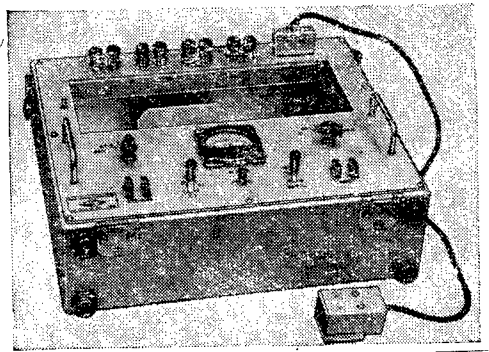

Figure 4.29. The main part of the PKUS .

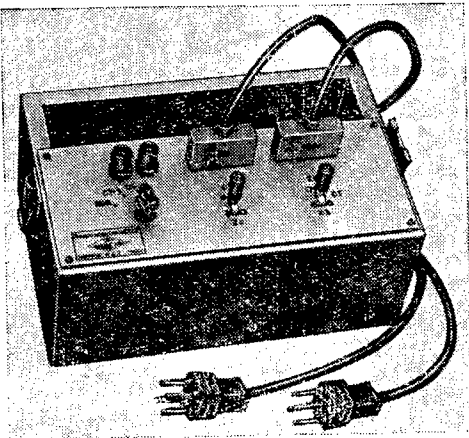

Figure 4.30. The supplemental part of the PKUS.

The PKUS permits setting up the circuits necessary for aligning the amplifiers, measuring the gain and checking the stability, as well as for measuring the collector currents of transistors.

The PKUS device consists of two parts: the main part (Figure 4.29) and the supplemental part (Figure 4.30). During the alignment, the main part of the device is connected by a connecting cable to the work location of the amplifier being aligned.

An audio frequency generator, a level meter, and a DTN transformer of the same type as those inserted in the line are connected to this part of the PKUS. The supplemental part of the PKUS serves for placing the requisite loads on the end of the circuit and is connected to this circuit by means of cables through the VKU switch field. During the alignment, the supplemental part of the PKUS should be operated by a technician who makes the requisite switch connections on the instructions of the alignment technician.

Besides the PKUS, an audio frequency generator of any type with a balanced output, and a level meter with a balanced high impedance (greater than 5 KOhms) input are required for the amplifier alignment.

## CHAPTER: RECOMMENDATIONS FOR THE PROJECT PLANNING OF RURAL TELEPHONE EXCHANGES

### 8.1. Selecting Rural Telephone Exchange Equipment

It is recommended that ATS K-50/200 and K-50/200M be used on rural telephone networks as the OS's [terminal exchanges] and US's [junction centers], and the ATS K-100/2000<sup>1</sup> be used for the TsS's [central exchanges]. The ATS K-100/2000 of VNR [Hungarian People's Republic] manufacture is recommended for use only in those cases where the maximum capacity of the exchange does not exceed 2,000 numbers.

Setting up an ATS K-50/200 type exchange as an OS is economically inexpedient at populated points where the number of telephones runs up to 20. At such points, the use of group installations, GU's, is recommended.

Relay and crossbar ATS-40/80's should be used for the maximum possible amount of time. This type of ATS may be replaced only because of considerations of inadequate capacity or when going over to outgoing automatic long distance communications, for which they are not suitable. The organization of incoming automatic and semi-automatic long distance communications is possible when any type of rural ATS is present on the network.

Ten step junction ATS's of the UATS-50/100 type should be gradually phased out, using them on the networks as terminal exchanges connected directly into a central exchange.

It is also recommended that existing central exchanges of the ATS-100/500, ATS-47 or ATS-54 be used in the future, only the numeration should be brought up to five digits by means of adding selector stages. When introducing outgoing automatic long distance communications, these exchanges, just as the ATS K-50/200 and ATS K-100/2000 type exchanges, should be fitted out with the equipment for automatic determination of the calling subscriber number, AON.

### 8.2. Figuring the Equipment Volume. The Number of Junction Lines to a Junction Center or Central Exchange

The equipment volume is not computed for low capacity rural terminal exchanges. The number of junction lines to a junction center or central exchange is taken from the data of Table 8.1.

The through working equipment and the number of interexchange junction lines is figured for a junction center or central exchange of any capacity. In this

---

<sup>1</sup> The ATS K-100/2000's can be used as a US and OS if the capacity of the exchange being planned will exceed 200 numbers in the coming five years.

case, the maximum number of junction lines which can be connected to exchanges of different types, which is given in Table 8.2, should be taken into account.

TABLE 8.1. The Maximum Number of Junction Lines to a Junction Center or Central Exchange from Terminal, Low Capacity Automatic Telephone Exchanges

Type of Terminal ATS	Number Capacity	Number of Two-Way Junction Lines
The VRS-20M relay ATS	20	2
Relay, unit ATS-10/40	10	2
" "	20	3
" "	30	4
" "	40	4
Ten step UATS-50/100 and 50/100M	50	4
Ten step ATS-100/500 and 100/500M	100	7
" "	200	13
Crossbar ATS K-40/80	40	4
" "	80	6
Crossbar ATS K-50/200	50	5
" "	100	7
" "	150	10
" "	200	13
Crossbar ATS K-50/200M		
" "	50	7
" "	100	10
" "	150	14
" "	200	17

If two-way junction lines are used in a bundle of up to 13 junction lines, it is recommended that with a greater number of lines, a transition be made to one-way junction lines (incoming and outgoing).

#### The Initial Data for the Determination of Telephone Traffic Quantities

To calculate the number of instruments and interexchange junction lines, the following statistical data for telephone traffic are required, which should be determined through operation on the basis of systematic observation:

TABLE 8.2. The Maximum Number of Junction Lines and Directions for Junction Centers and Central Exchanges of Different Types

Type of Rural ATS	Maximum Number	
	Of Junction Lines	Of Directions
Ten step junction ATS-50/100 with a capacity of 50 numbers	40	9
The same, with a capacity of 80 numbers	10	5
Crossbar junction ATS K-40/80	50	15
Crossbar junction ATS K-50/200 and K-50/200M	49	15
Crossbar junction and central ATS K-100/2000 <sup>1</sup>	any number	any number
Ten step junction and central ATS K-100/500 <sup>1</sup>	"	"

<sup>1</sup> When the number of outputs from the GI [group selector] field is inadequate to provide the requisite number of directions and number of junction lines, an additional GI stage is introduced.

TABLE 8.3. The Average Values of C and T for Determining Telephone Traffic Quantities

Character of the populated points	1. Категория абонентов						Доля вызовов, заканчивающихся разговором
	2. сектор		3. тор		4. томаты		
	C <sub>к</sub>	T <sub>к</sub>	C <sub>нх</sub>	T <sub>нх</sub>	C <sub>та</sub>	T <sub>та</sub>	
6. При числе абонентов квартирного сектора до 65%							
7. Города и села с населением до 20 тыс. чел.	0,7	100	2,4	80	6	110	0,65
8. То же, от 20 до 100 тыс. чел.	0,8	110	2,7	85	8	110	0,65
9. То же, от 100 тыс. до 500 тыс. чел.	0,9	110	3,0	85	10	110	0,6
10. При числе абонентов квартирного сектора более 65%							
7. Города и села с населением до 20 тыс. чел.	0,8	130	1,6	90	6	110	0,65
8. То же, от 20 до 100 тыс. чел.	0,9	140	1,9	90	8	110	0,65
9. То же, от 100 тыс. до 500 тыс. чел.	1,0	140	2,2	90	10	110	0,6

Key: 1. Subscriber category; 2. Apartment sector; 3. National economic sector; 4. Pay telephones; 5. Fraction of call-ups which result in conversation; 6. When the number of apartment sector subscribers runs up to 65%; 7. Cities and towns with a population of up to 20,000; 8. Same as above, from 20 to 100,000 persons; 9. Same as above, from 100,000 to 500,000 persons; 10. When the number of apartment sector subscribers is greater than 65%.

1. The average number of calls, C, coming in to one subscriber during peak load hours (chmn):
  - Of the apartment sector;  $C_k$
  - Of the national economic sector;  $C_{HX}$
  - Of a coin operated telephone line;  $C_{ta}$
2. The average duration of a conversation in seconds:  $T_k$ ,  $T_{HX}$ ,  $T_{ta}$  respectively.
3. The fraction of call-ups of the overall number of call-ups,  $P_p$ , which result in in conversation.
4. The structural composition of the subscribers in percent of the overall number.
5. Traffic distribution with respect to the direction (for junction centers and central exchanges).

When the statistical data for C, T and  $P_p$  is lacking, it is recommended that the amount of telephone traffic be determined from the average figures of Table 8.3, taking into account the structural composition of the subscribers.

#### Determining the Outgoing Load Quantities

The magnitude of the outgoing design load, developed on rural ATS's of the ten step system, is determined in terms of traffic units using the following formula:

$$Y_{out} = Y_{HCX} = 1.1 P_p [N_{HX} C_{HX} (t_{co} + t_H + t_B + T_{HX}) + N_k C_k (t_{co} + t_H + t_B + T_k) + N_{ta} C_{ta} (t_{co} + t_H + t_B + T_{ta})] \frac{1}{3600} + Y_{ytc}$$

where 1.1 is the factor taking into account the load created by call-ups which do not result in conversation;  
 $P_p$  is the factor taking into account the fraction of the calls resulting in conversation (0.65);  
 $N_{HX}$ ,  $N_k$ ,  $N_{ta}$  are the numbers of telephones in the national economic and apartment sectors, as well as pay telephones, respectively;  
 $t_{co}$  is the average time the subscriber hears the exchange answering signal;  
 $t_H$  is the time for dialing the number, in seconds, equal to 1.5 n, where n is the number of digits in the number;  
 $t_B$  is the average time for listening to all of the call-up transmission signal (10 seconds);  
 $Y_{ytc}$  is the load created by the agencies' telephone exchanges [PBX's], in traffic units.

The size of the outgoing design load on an ATS K-100/2000 is determined in traffic units from the following formula:

$$y_{ucx} = 1,1 P_D [N_{HK} C_{HK} (t_B + t_{per} + T_{HK}) + N_K C_K (t_B + t_{per}) + T_K] + N_{TA} C_{TA} (t_B + t_{per} + T_{TA}) + y_{ytc} \cdot t_{per} = t_{co} + t_H + t_{yucx},$$

where  $t_{yucx}$  is the time for making a connection after the subscriber number is established in the register (2.5 seconds).

The Number of Junction Lines to Agency's Telephone Exchanges (UTS's) [PBX's]

The number of junction lines from a UTS is determined by a calculation based on the statistical data for telephone loading. In the absence of the statistical data, it is recommended that the number of junction lines be taken from Table 8.4.

TABLE 8.4.

The Recommended Number of Junction Lines From an Agency's Telephone Exchange

- Key:
1. The number of subscribers having the right to outside communications;
  2. The number of junction lines outgoing to rural exchanges;
  3. The number of junction lines incoming from rural exchanges.

1. Количество абонентов, имеющих право внешней связи	2. Количество соединительных линий, исходящих на сельские станции	3. Количество соединительных линий, входящих от сельских станций
50	3	3
100	5	5
200	9	8
300	11	10
400	13	12
500	15	14
600	17	16
700	20	18
800	22	20
900	24	22

The Recommended Norms for Losses at Rural Telephone Exchanges

The norms for the losses (p) to determine the number of instruments for the selector stages are given in Tables 8.5 and 8.6.

The loss norms are defined as a function of the capacity of the ATS which is directly tied to the exchange being planned.

The Number of Test Desks and Information Desks

At ATS K-100/2000's, supplied by the VNR [Hungarian People's Republic], it is necessary to set up one measurement and test desk. The testing of subscriber



TABLE 8.5. Losses for Interexchange Connections

Selector Stage	Loss Norm	
	For the ATS K-100/2000	For ten step ATS's
AI's [subscriber selectors]:		
-- For outgoing traffic	0.005	-
-- For incoming traffic	0.002	-
GI [group selector]	0.005	0.003
GIM and LIM [long distance group selector and long distance line connector]	-	0.001
LI [Line selector]	-	0.005
RI [register finder]:		
-- When inserted in RI racks of ShK [?cord complex?], RSLV-BZ, VShMK [?incoming long distance cord set?], and VShKMA [?auto- matic incoming long distance cord set?] complexes	0.002	-
-- When inserted in RI racks of RSLV-I [?incoming-outgoing line connector relay?] complexes	0.02	-

Table 8.6 Losses for Incoming and Outgoing Outside Connections for GI's [Group Selectors]

Capacity of the ATS, numbers	Existing Developmental Period (up to 1975)	Short Term (Up to 1980)	Long Term (After 1980)
40 - 100	0.10	0.05	0.003
More than 100	0.05	0.03	0.02

lines at other rural ATS's is provided for by means of test and measurement instruments included in the ATS equipment complement.

Information desks are set up for the entire rural telephone network at the central exchange, depending on the equivalent capacity of the network:

- Up to 3,000 numbers: 1 desk;
- Up to 6,000 numbers: 2 desks;
- Up to 8,000 numbers: 3 desks;
- Up to 10,000 numbers: 4 desks;
- More than 10,000: one desk for each subsequent 2,000 numbers.

The equivalent capacity of a rural telephone network for establishing the number of information desks is equal to:

$$N = N_1 + kN_2$$

where  $N_1$  is the central exchange capacity in numbers, while on a regionalized network, it is the total capacity of the regional center ATS;

$N_2$  is the overall capacity of the rural junction centers and terminal exchanges;

$k$  is a factor less than 1, taking into account local conditions, and derived from operation.

### 8.3. The Equipment Layout for Rural Automatic Telephone Exchanges

#### General Principles

The equipment of rural ATS's, in particular, low capacity ATS's (up to 200 numbers), should, as a rule, be housed in common rooms with the radio equipment. The choice of the room for the ATS, as well as the layout of the equipment, should take into account the final capacity of the ATS. For equipment needed during expansion, free places are reserved in the end-frame of equipment racks.

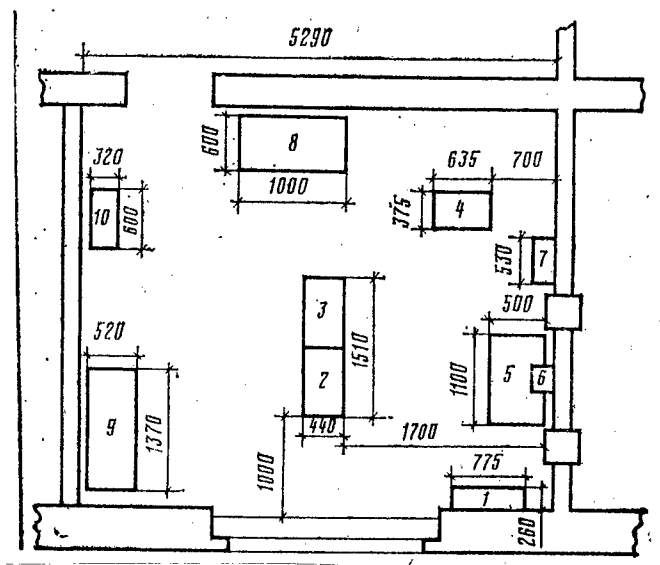

Figure 8.1. Plan for the equipment layout of an ATS K-40/80 80 number central exchange.

Key: 1. VKU [input switching unit]; 2. Main rack; 3. Supplemental rack; 4. TU-600; 5. Desk with RTU receivers and rectifiers; 6. Antenna panel; 7. Line panel; 8. Working desk; 9. Cabinet for the storage batteries, NZhN-45.

The planning of the technical accommodations for rural ATS's is given in typical project plans for the construction of rural stations of various types and capacities, developed by the Leningrad Department of the "Giprosvyaz'" institute. When relating to local conditions, it is necessary to consider the actually available facility for arranging the equipment, the volume of through working equipment at the junction center, the requisite volume of equipment at the central exchange (based on calculations), as well as the equipment complement for electrical and radio communications which can be installed in the common room, making allowances for expansion.

Given below are layout plans for equipment taking from typical project plans.

### The Crossbar ATS K-40/80

The ATS K-40/80 equipment is installed in double sided floor racks with dimensions of 2,240 x 755 x 440 mm.

A 40 number subscriber block is housed in one rack. One main rack is installed at 40 number capacity ATS's, and at ATS's with a capacity of 80 numbers, one main rack and one supplemental rack are installed.

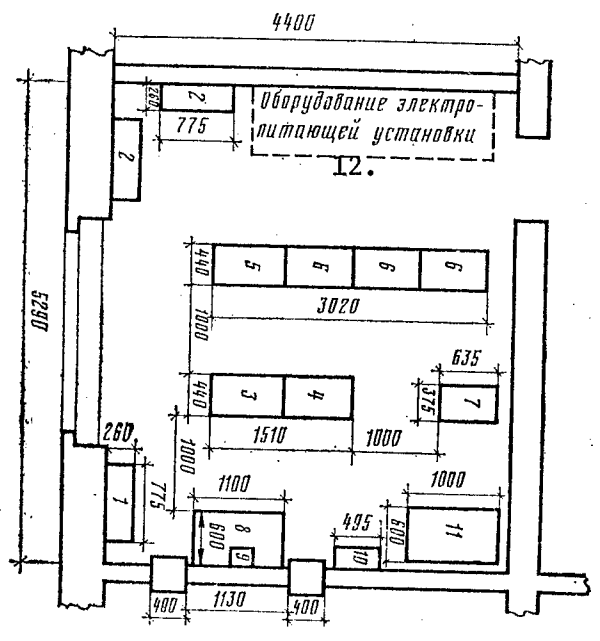

Figure 8.2. Equipment layout for a junction center 80 number ATSK-40/80

Key: 1. Subscriber line input unit; 2. Junction line input unit; 3. Main SU rack; 4. Supplemental SU rack; 5. Main TU rack; 6. Supplemental TU rack; 7. TU-600; 8. Desk with RTU receivers; 9. Antenna panel; 10. Line panel; 11. Work desk; 12. Electrical power supply equipment.

The through calling equipment, which is installed at a junction center, is housed in two racks, which differ in their construction: the main TU rack for eight junction lines, and an additional TU rack for 14 junction lines. Depending on the number of junction lines, installed at a junction center are one main, and one to three supplemental racks.

A typical layout for the equipment of a terminal exchange of the ATS K-40/80 type with a capacity of 80 numbers is shown in Figure 8.1, while a junction center with a capacity of 80 numbers is shown in Figure 8.2. The ATS equipment is housed jointly with the radio communications equipment. The ATS K-40/80 racks create a floor loading of 450 kg per 1 m<sup>2</sup> of room area.

### The Crossbar ATS K-50/200

The number of racks which can be installed depends on the installation capacity of the ATS. The equipment of a terminal exchange with a capacity of 200 numbers is placed in four floor type racks, each with dimensions of 2,240 x 775 x 440 mm.

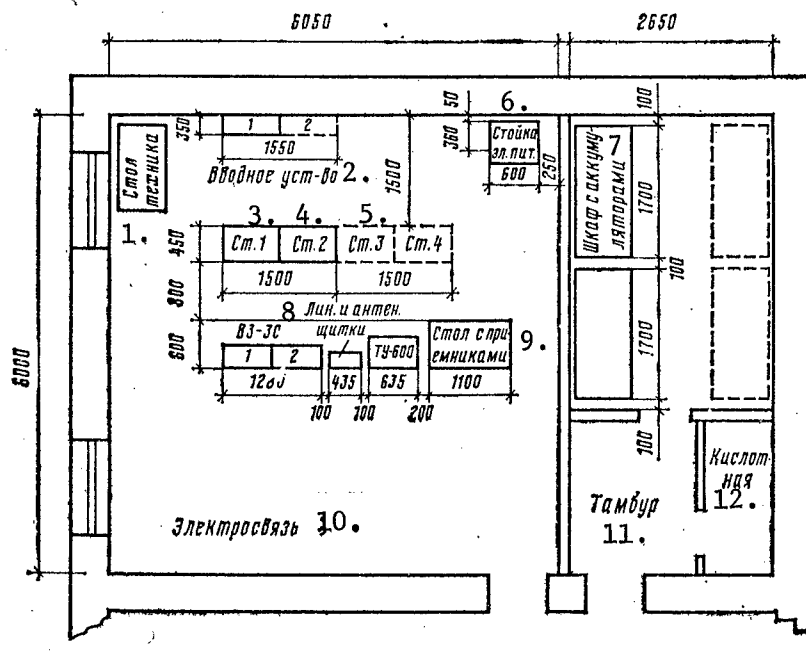

Figure 8.3. Layout of the terminal exchange equipment for an ATS K-50/200 with a capacity of 100 numbers with an expansion capacity of up to 200 numbers.

- Key: 1. Technician's desk; 2. Input unit; 3. Rack 1; 4. Rack 2; 5. Rack 3; 6. Electrical power supply bay; 7. Cabinet with the storage batteries; 8. Line and antenna panels; 9. Desk with receivers; 10. Electrical communications service; 11. Vestibule; 12. Acid room.

The same racks are installed at junction centers as subscriber equipment as at the terminal exchanges, only in place of RSLO's [?line connector relay equipment?] they are assembled with ShKV [?incoming cord connector?] complexes. The through working equipment is housed in racks of the same design. Located in the first main TU rack are 7 junction line relay (RSL) complexes and in the three supplemental racks, 14 complexes each.

The typical layout of the equipment of a terminal exchange with a 100 number capacity K-50/200 and an expansion capacity up to 200 numbers is shown in Figure 8.3, while a junction center with a capacity of 50 numbers and an expansion capability of up to 100 numbers, is shown in Figure 8.4. The ATS equipment is colocated with the radio communications equipment. The ATS K-50/200 racks create a load on the floor of 450 Kg per 1 m<sup>2</sup> of room area.

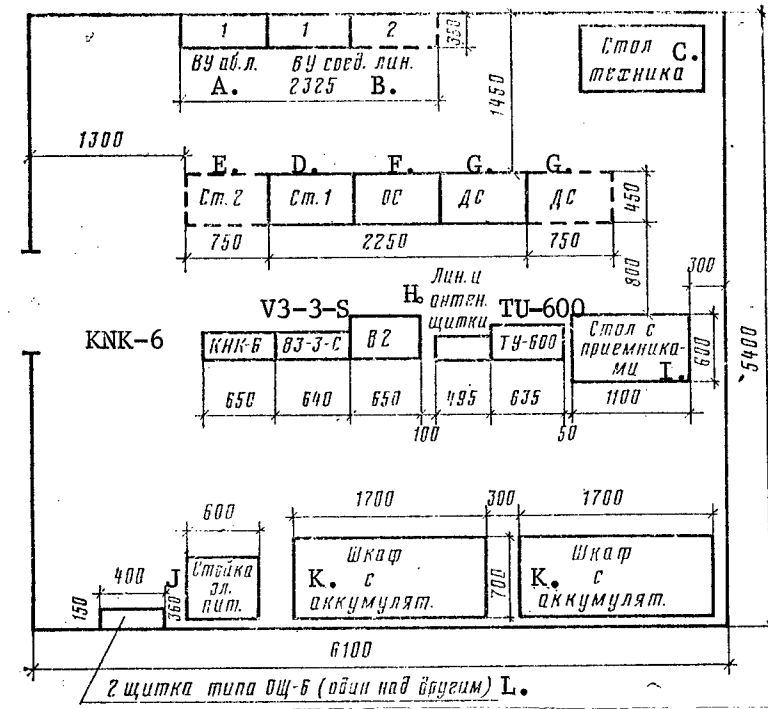

Figure 8.4. Equipment layout for a junction center ATS K-50/200 with a capacity of 50 numbers and an expansion capability up to 100 numbers.

Key: A. Subscriber line input unit; B. Junction line input unit; C. Technician's desk; D. Rack 1; E. Rack 2; F. OS [terminal station]; G. DS [expansion unknown]; H. Line and antenna panels; I. Desk with receivers; J. Electrical power supply bay; K. Cabinet with storage batteries; L. Two OShch-6 type panels (one above the other).

## The Ten Step ATS 100/500

The overall height of the equipment, along with the channels, is three meters. The height of the technical facilities from the floor to the lowest point on the ceiling should be 3,200 mm for the automatic switching room, the distribution frame and rectifier rooms, and for the storage battery room, the height of the facility should be 3,000 mm.

The floors between stories for the automatic switching room and the distribution frame should be designed for a loading of 450 Kg per m<sup>2</sup>. The floor at the point where the rectifiers are set up should sustain a concentrated load of 2,000 Kg.

Rough figures for the installation of ATS equipment with a capacity of 200 to 300 numbers require an automatic switching room area of about 30 m<sup>2</sup>, and for a capacity of 500 numbers, about 40 m<sup>2</sup>. The area of the storage battery room is 15 m<sup>2</sup>. When installing ATS storage batteries, along with MTS [long distance telephone exchange] and LATs [line equipment shop] batteries, as well as automatic equipment together with LATs and radio communications equipment, the area of the requisite room increases correspondingly, depending on the volume of the additional equipment. In this case, the requisite facility area is determined based on the specific plan for the equipment layout.

TABLE 8.7. Structural and Design Dimensions of ATS 100/500 Racks

1. Наименование стativoв	2. Ширина мм	3. Глубина мм	4. Расчетная ширина мм
5. ИПИ	548	243	580
6. ИГИ-ГИМ	410	255	470
7. ЛИ-ЛИМ	526	255	580
8. ИГИ-ВГМ	465	255	515
9. ВГИ	333	255	390
10. ДУ	441	200	500
11. РСЛ-ПК	561	180	630
12. РСИ-6	550	—	600
13. СВУ	401	180	450
14. Каркас ПЩ	535	315	720
15. Кросс на 1-ю ячейку	1300	595	—
16. Кросс на 2-ю ячейку	1700	595	—
17. Правый угольник	70	—	—
18. Левый угольник	60	—	—

Key: 1. Rack designation; 2. Width, mm; 3. Depth, mm; 4. Design width, mm; 5. IPI, preselector 1; 6. IGI-GIM, group selector 1 - long distance group selector; 7. LI-LIM, line connector - long distance line connector; 8. IGI-VGM [Expansion unknown]; 9. VGI [Expansion unknown]; 10. DU; 11. RSL-ПК [Expansion unknown]; 12. RSI-6; 13. SVU; 14. PShch chassis; 15. Distributing frame for the first cell; 16. Distributing frame for the second cell; 17. Right elbow; 18. Left elbow.

TABLE 8.8. Dimensions of Passageways in the ATS 100/500 Automatic Switch Room

Section Designation	Spacing Between Row Centers, mm	Minimum Spacing, mm
Passage between the rows without PShch	1,050	725
Passage between the rows with PShch	1,150	730
Passage between the wall (projection) and the row without PShch	900	740
Passage between the wall (projection) and with PShch	950	740
Side passage between the end of the row and the wall	600	600

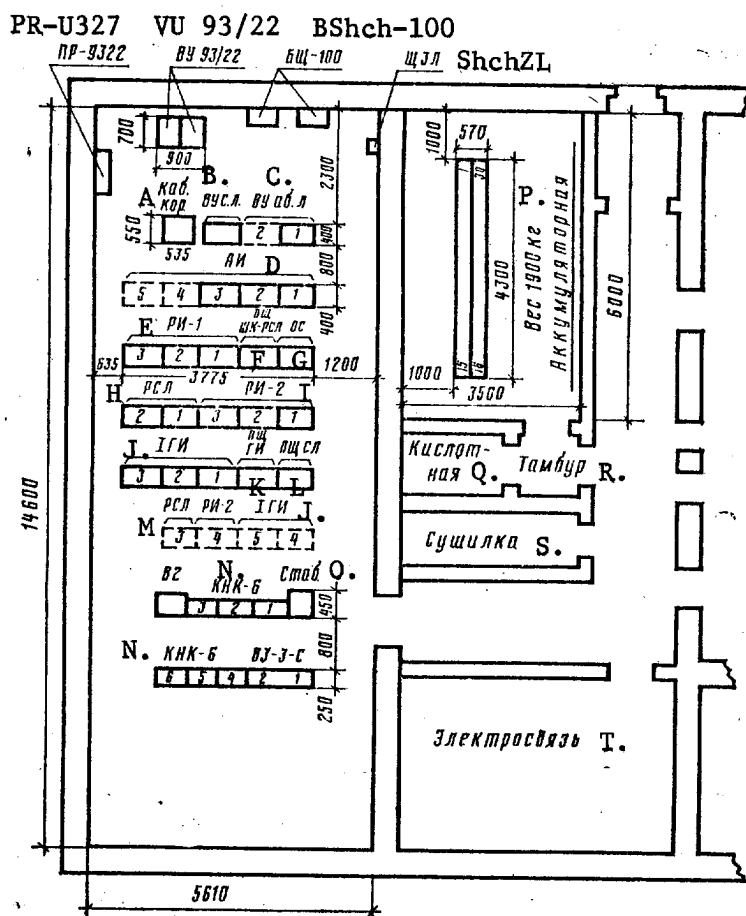

Figure 8.5. Layout plan for the equipment of a junction center ATS K-100/2000 with a capacity of 300 numbers and the capability of expanding to 500 numbers.

Key:

- A. Cable boxes;
- B. Junction line input unit;
- C. Subscriber line input unit;
- D. Subscriber selector;
- E. RI-1 [register finder 1];
- F. PShch, ShK-RSL;
- G. OS [terminal station];
- H. RSL [connector relays];
- I. RI-2;
- J. I GI [group selector 1];
- K. PShch, GI;
- L. PShch SL;
- M. RSL;
- N. KNK-6;
- O. Regulator;
- P. Weight 1,900 Kg; storage battery room;
- Q. Acid room
- R. Vestibule;
- S. Dryer;
- T. Electrical communications service.

The structural and design dimensions of the racks of the rural ten step ATS 100/500 are given in Table 8.7.

When laying out the ATS 100/500 rack rows, the dimensions of the passageways should correspond to those given in Table 8.8.

With a two sided layout of the rows with the racks in the automatic switching rooms with the central main passage, an effort should be made to have the

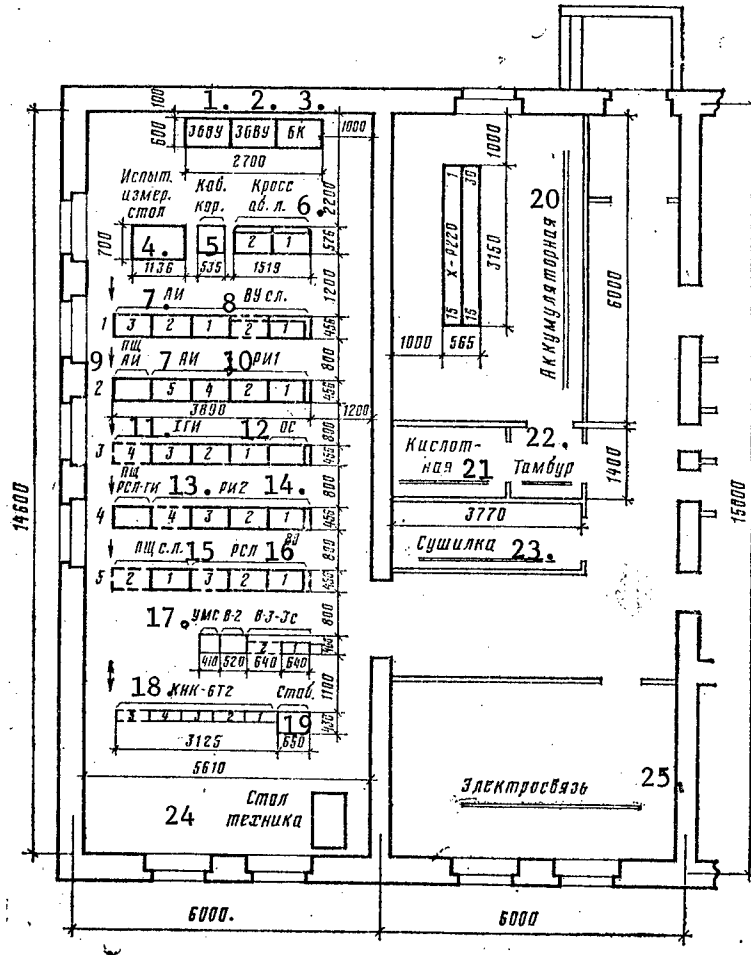

Figure 8.6. The equipment layout for a junction center ATS K-100/2000 with a capacity of 500 numbers.

Key: 1,2. ZBVU [expansion unknown]; 3. BK [expansion unknown]; 4. Test and measurement desk; 5. Cable boxes; 6. Subscriber line distribution frame; 7. Subscriber selector; 8. Junction line input unit; 9. Subscriber selector PShch [expansion unknown]; 10. RII [register finder 1]; 11. Group selector; 12. OS [terminal station]; 13. PShch line connector-group selector; 14. Register finder 2; 15. Junction line PShch;



[Key to Figure 8.6 Continued]: 16. RSL [connector relays]; 17. UMS-V-2 [bridging amplifier V-2], V-3-3S; 18. KNK-6T2; 19. Regulator; 20. Storage battery room; 21. Acid room; 22. Vestibule; 23. Dryer; 24. Technician's desk; 25. Electrical communications service.

center lines of the rack rows of both halves of the automatic switching room coincide. The face of the racks should be turned towards the main entrance into the automatic switching room (from the side of the main entrance into the ATS building).

The following dimensions should be provided in the automatic switching room for the main passage:

- For the case of a two-sided layout of the rows, 1,500 mm;
- For a one-sided row layout, 1,300 mm.

The passage between a column and the face of the nearest rack row should be no less than 700 mm.

#### The Crossbar ATS K-100/2000

The height of the automatic switching room for the ATS K-100/2000 to the lowest point of a beam should be no less than 3 m, and where multiplex equipment is used, no less than a height of 2,100 - 2,200 mm. When using multiplex equipment 2,500 - 2,600 mm high, the height of the room should go up to 3,200 mm. The carrying capacity of the floor under the automatic switching room should be no less than 750 Kg per m<sup>2</sup> of room area.

Used in an ATS K-100/2000 are two sided racks with a width of 752 mm, the design width is 755 mm; the depth at the base is 400 mm and with the instruments is 440 mm. The design width of VNR produced racks is 762 mm, and the depth is 456 mm.

Shown in Figure 8.5 is a typical plan for the layout of domestic equipment in a junction ATS K-100/2000 with a capacity of 300 numbers, with the capability of expanding to 500 numbers. Shown in Figure 8.6 is the layout for the equipment of the same ATS (capacity 500 numbers) consisting of VNR [Hungarian People's Republic] produced equipment. A signaling rack 80 mm wide is set up at the end of each row.

A plan for the equipment layout of a central exchange with a capacity of 800 numbers, with the capability of expanding up to 1,500 numbers is shown in Figure 8.7.

The passage clearances given in Table 8.9 should be maintained for the rack rows of the ATS K-100/2000.

#### Distribution Frames



Рис. 8.7. План расположения оборудования сельской ЦС АТС К-100/2000 на 800 номеров с расширением до 1500 номеров

Figure 8.7. The equipment layout for a rural central exchange ATS K-100/2000 for 800 numbers with an expansion capability up to 1,500 numbers.

- Key: 1. Adjustment room; 2. Rectifier room; 3. Automatic switch room; 4. Technician's desk; 5. Line equipment shop; [AC] regulator; 6. KNK; 7. PSP; 8. Distribution frame, expanded; 9. Distribution frame; 10. Line side; 11. Test desk; 12. Distribution frame room; 13. Acid room; 14. Vestibule; 15. Storage battery room; 16. Subscriber selector; 17. Subscriber selector, expanded; 18. Register finder 1; 19. Register finder 1, expanded; 20. Terminal station; 21. Group selector 1 PShch; 22. Group selector 1; 23. Group selector 1, expanded.

For rural ATS K-100/2000's with a capacity of 300 numbers and more, an open type distribution frame should be provided, while for exchanges with a lower capacity, an input switching unit (VKU) for 300 subscribers should be provided.

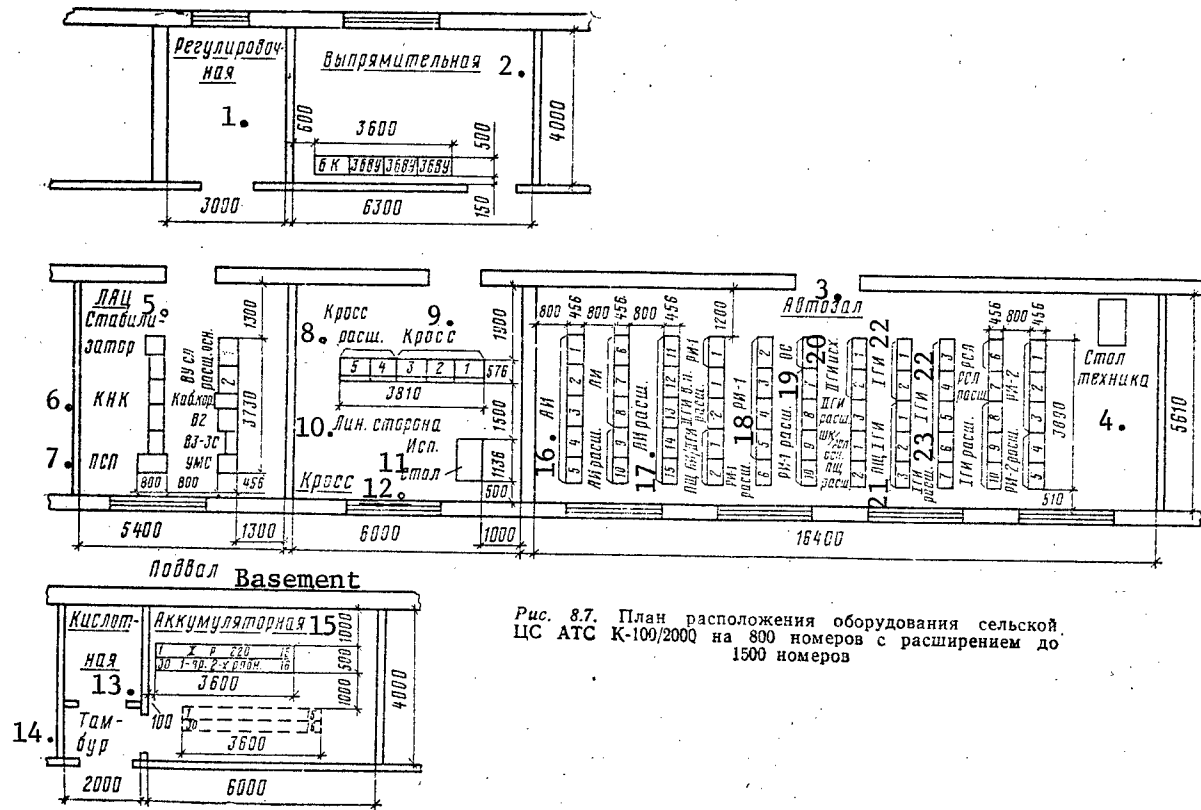
Included in the equipment complement of the ATS K-100/2000 of VNR manufacture is an open type distribution frame for an ATS of any capacity.

TABLE 8.9. Passageways at an ATS K-100/2000

Section	Designation	Minimum Spacing mm
	Passage between rows	800
	Passage between a wall and a row	800
	Side passage between the end of a row and a wall	600

The frameworks for the subscriber distribution frame, as well as the test desks and measurement instruments, should be located in the distribution frame rooms of rural ATS's. The installation in the distribution frame of racks with amplifiers and up to two information desks is permitted. When placing the distribution frames in one row, the line side should face the window. When the distribution frames are arranged in parallel rows, the line sides should face each other.

TABLE 8.10. Passageways in the Distribution Frame Room

Section	Designation	Passage Size, mm
	Passage between the rows of the distribution frame	1,500
	Passage between the exchange side of the distribution frame and a wall	800
	Passage between the line side of the distribution frame and a wall	1,200
	Side passage between the end of the distribution frame and a wall	800
	Passage from the rear of the desks	800
	Passage from the front of the desks	1,500
	Distance from a wall to the end face of the desks, where there is a side passage from the other side of the desks	200

When laying out the distribution frames, test and information desks, the passage clearances indicated in Table 8.10 should be observed.

#### The Line Equipment Shop

Rural telephone network LATs's [Line equipment shops] should be present at:

- Central ATS's, as a rule, in individual rooms or in one room with the long distance exchange LATs;
- At junction centers, depending on the HF multiplex equipment volume, determined by the long term circuit configuration for rural telephone network development;

TABLE 8.11. Rack Dimensions for the Multiplex Equipment of Rural Networks

Наименование аппарата, 1. туры	Dimensions Размеры, мм мм
ВЗ-3-С V3-3-S	2150×650×250
КНК-6-Т-2 КНК-6-Т-2	2150×625×225
КНК-6-Т-4 КНК-6-Т-4	2630×625×225
2. Стабилизатор к аппаратуре КНК-6	
3. Каркас на 3 шт	2100×650×450
4. Каркас на 6 шт	2600×650×450
КНК-12 КНК-12	2600×600×225
ИКМ-12 ИКМ-12	2244×728×512
ВО-3-4 ВО-3-4	2100×680×250
СТ5 ST5	2150×650×400
СТН-2 STN-2	810×722×430
ПСП PSP	2500×526×816
5. Кабельные коробки каркас на 4 шт	2600×535×550

Key: 1. Equipment designation;  
2. Regulator for the КНК-6 equipment;  
3. Three piece frame;  
4. Six piece frame;  
5. Cable boxes, four piece frame.

3. The floors underneath the technical accommodations should be designed for the equipment load, and where necessary, correspondingly reinforced.

4. The floors of the facilities should have a smooth surface. The use of hygroscopic materials beneath the flooring is not permitted.

5. The rooms should be dry, well ventilated, and have natural illumination.

6. The artificial electrical lighting of the technical accommodations should be handled in accordance with the "Construction Norms and Rules", VTU 122-60, and the "Rules for the Devices of Electrical Facilities", Section VI, "Electrical Illumination", (Moscow, Gosenergoizdat, 1959).

7. The convective and exhaust ventilation, and the heating of the rooms should be in accordance with the requirements of Technical Regulation: "Civil Enterprise Wire and Postal Communications Works" (TU 588-60)<sup>1</sup>.

<sup>1</sup> New technical regulations are being worked out at the present time (NTP 588-71).

-- At terminal exchanges, as a rule, in a common room with the ATS equipment.

Given in Table 8.11 are the dimensions of multiplex equipment and input devices used on rural telephone networks.

#### The Engineering Requirements Placed on Rooms for the Installation of Electrical and Radio Communications Equipment

1. The facilities provided for the installation of electrical and radio communications equipment on rural telephone networks should be assigned to buildings which meet the requirements of no less than the III Fire Resistance Category.

For forested and remote regions, the use of buildings in the IV-V Fire Resistance Categories is permitted

2. The dimensions of the technical accommodations should permit the option of housing the equipment in them, taking prospective development into account.

Where furnace heating is used, the furnace should not extend into the technical rooms.

8. The height of the rooms from the floor to the bottom of a joist beam or the ceiling should be in accordance with requirements, depending on the type of equipment being installed, but no less than 3 m.

[No number 9 in text]

10. The floor of the equipment room should be either parquet or planked, and covered with relin [term unknown], plastic or linoleum. The walls and ceiling are painted with oil base paint.

11. The relative humidity of the equipment should be within limits of 45 - 75%.

12. The height of the storage battery room from the floor to the bottom of a ceiling beam or joist should be no less than 2.4 m.

13. Access into the storage battery room should be through a vestibule, both doors of which should open outward. The vestibule should have dimensions such that the inside door can be opened and closed when the outside door is closed.

14. The floor of the storage battery room should be concrete, covered with asphalt or vitreous floor tile on acid resistant cement.

15. The walls and ceiling of the storage battery room are painted with acid resistant paint.

16. The storage battery room is equipped with special convective and exhaust ventilation, for which special ducts are provided.

17. A special hermetically sealed electrical lighting fixture should be used in the storage battery room, the lead-in to which comes through with the conductor in a hermetically sealed, acid resistant jacket.

The installation of switches, connector plugs and fuses is not permitted in the storage battery room.

APPENDIX 1

Norms for the Electrical Characteristics of the Amplified Sections of Open Wire Interexchange Communications Lines Multiplexed with High Frequency Equipment

APPENDICES

Характеристика Characteristic	Единица измерения I.	Частота тока 2. ° Клц	3. Нормы при уплотнении стальных проводов различного диаметра аппаратурой УДК-1, УДК-2, В-2-2, В-3-3с		
			3 мм	4 мм	5 мм
4. Сопротивление основной цепи при температуре +20°С. не более	$\Omega/\text{Км}$ Ом/км	DC пост. ток	43,0	24,2	15,5
5. Разность сопротивлений проводов основной цепи, не более	Ом/с Ом		30,0	5,0	5,0
6. Сопротивление изоляции каждого провода по отношению к земле в сырую погоду (90% влажности воздуха), не менее	$\text{М}\Omega \cdot \text{Км}$ МОм.км		2,0	2,0	2,0
7. Сопротивление изоляции между проводами цепи в сырую погоду (100% влажности воздуха), не менее	МОм.км		4,0	4,0	4,0
8. Разница в величинах сопротивлений изоляции проводов по отношению к земле, не более	%		30,0	30,0	30,0

Key: 1. Unit of measurement; 2. Frequency, KHz; 3. Norms when multiplexing steel conductors of different diameters using the UDK-1, UDK-2, V-2-2 and V-3-3s equipment; 4. Resistance of a physical circuit at a temperature of +20° C, no more than; 5. Difference in the resistances of the conductors of a physical circuit, no more than; 6. Insulation resistance of each conductor with respect to ground during damp weather (90% air humidity), no less than; 7. Insulation resistance between the circuit conductors in damp weather (100% air humidity), no less than; 8. Difference in the amount of insulation resistance of the conductors with respect to ground, no more than.

APPENDIX 1 [Continued]:

Характеристика Characteristic	Единица измерения 1.	Частота тока кГц 2.	3. Нормы при уплотнении стальных проводов различного диаметра аппаратурой УДК-1, УДК-2, В-2-2, В-3-3с		
			3 мм	5 мм	4 мм
4. Переходное затухание на ближнем конце между основными цепями, не менее	дБ, (Nep) дБ (Hп)	0,8 4-31	69,5 (8,0) 60,8 (7,0)	69,5 (8,0) 60,8 (7,0)	69,5 (8,0) 60,8 (7,0)
5. Защищенность между основными цепями на дальнем конце, не менее	дБ (Hп)	4-31	56,5 (6,5)	56,5 (6,5)	56,5 (6,5)
6. Асимметрия основной цепи на ближнем конце, не менее	дБ (Hп)	0,8 4-31	66,0 (7,5) 43,4 (5,0)	65,2 (7,5) 43,4 (5,0)	65,2 (7,5) 43,4 (5,0)
7. Линейные помехи (шумы), не более	дБ (Hп)	0,8 4-31	65,2 (7,5) 78,2 (9,0)	65,2 (7,5) 78,2 (9,0)	65,2 (7,5) 78,2 (9,0)
8. Переходное затухание между выходом и входом одной уплотненной цепи в НУП (ОУП), не менее	дБ (Hп)	4-31	65,2 (7,5) 78,2 (9,0)	65,2 (7,5) 78,2 (9,0)	62,2 (7,5) 78,2 (9,0)
9. Переходное затухание между выходом одной и входом другой уплотненных цепей, не менее	дБ (Nep)	4-31	10, НУП-91,2 (10,5) ОС (ОУП)-110,3 (12,7)	10, НУП-91,2 (10,5) ОС (ОУП)-110,3 (12,7)	10, НУП-91,2 (10,5) ОС (ОУП)-110,3 (12,7)

Key: 1. Unit of measurement; 2. Frequency, KHz; 3. Norms when multiplexing steel conductors of different diameters using UDK-1, UDK-2, V-2-2, and V-3-3s equipment; 4. Near end crosstalk attenuation between physical circuits, no less than; 5. Far end isolation between physical circuits, no less than; 6. Near end imbalance in a physical circuit, no less than; 7. Line interference (noise) no more than; 8. Crosstalk attenuation between the output and input of one multiplexed circuit in a NUP (or OUP), no less than; 9. Crosstalk attenuation between the output of one and the input of another multiplexed circuit, no less than; 10. Unattended amplifier station: 91.2 (10.5); Terminal exchange (terminal amplifier station): 110.3 (12.7).

APPENDIX 2

Norms for the Electrical Characteristics of Amplified Sections of Interexchange Cable Lines, Multiplexed with High Frequency Equipment

Характеристика Characteristic	Единица измерения 1.	Частота тока кГц 2.	3. КНК-6-		V-3-3S		B-3-3C		6. ИКМ-12М	
			VTSP (B) VTCP (B) 1X4X0,8 1X4X1,2	КСПП(В) 1X4X0,8; КСПП(К) 5X4X0,9;	МКРВ МКПВ 11X4X1,2	VSTP (B) VTCP (B) 1X4X1,2	VSTP (B) VTCP (B) 1X4X1,2	КСИП(В) 1X4X0,9 КСИП(К) 1X4X0,9		
8. Сопротивление цепи при температуре +20°C, не более — основной of a physical circuit — искусственный of a phantom	$\Omega/\text{Km}$ Ом/км	пост. ток DC	31,6 15,8	56,8 28,4	31,9 15,95	31,6 15,8	31,6 15,8	31,6 15,8	56,8 28,4	
9. Разность сопротивлений жил цепи, не более — основной of a physical — искусственный of a phantom	$\Omega$ Ом		1,5 1,0	2,0 1,5	1,0 1,0	1,5 1,0	1,5 1,0	1,5 1,0	2,0 1,5	
10. Сопротивление изоляции между каждой жилой и стальными жилами, соединенными с заземленным экраном, не менее: — основной цепи of a physical — искусственной цепи of a phantom	M $\Omega$ Km Мом. км.		10000 5000	10000 5000	15000 7500	10000 5000	10000 5000	10000 5000	10000 5000	
11. Сопротивление изоляции экранов по отношению к земле, не менее	Мом. км.		0,05	1,0	—	0,05	0,05	0,05	1,0	
12. Рабочая емкость, не более — основной цепи of a physical — искусственной цепи of a phantom	нФ/км пФ/км		43,5±2,0 115±5,0	38,0±2,0 100,2±5,3	34,5±1,1 91,4±2,9	43,5±2 115±5	43,5±2 115±5	43,5±2 115±5	38,0±2,0 100,2±5,3	
13. Электрическая прочность изоляции между всеми соединенными жилами и экраном, между лучком жил «а» и жил «б» основных цепей, не менее	V, В	AC	15000	1500	2000	1500	1500	1500	1500	
14. Переходное затухание между цепями на ближнем конце, не менее — основной physical — искусственной и основной phantom and physical	дБ (Нп) дБ (Nep)	пер. ток 4-31 16-120 8-700 0,1-6,0	52,1 (6,0) 60,8 (7,0)	52,2 (6,0) 60,8 (7,0)	52,2 (6,0) 60,8 (7,0)	60,8 (7,0)	60,8 (7,0)	56,6 (6,5) 60,8 (7,0)	60,8 (7,0)	
15. Защищенность между основными цепями на дальнем конце, не менее	дБ (Нп) дБ (Nep)	AC пер. ток 4-31	—	—	—	—	—	—	—	
16. Переходное затухание между входом и выходом одной уплотненной цепи в НУП, ОУП, не менее	дБ (Нп) дБ (Nep)	AC пер. ток 4-31 16-120 8-700	78,2 (9,0)	78,2 (9,0)	78,2 (9,0)	78,2 (9,0)	78,2 (9,0)	78,2 (9,0)	78,2 (9,0)	
17. Асимметрия основной цепи на ближнем конце, не менее	дБ (Нп)	AC пер. ток 4-700	43,4 (5,0)	43,4 (5,0)	43,4 (5,0)	43,4 (5,0)	43,4 (5,0)	43,4 (5,0)	43,4 (5,0)	
18. Линейные помехи (шумы) основной цепи на ширине спектра одного канала, не более	дБ (Нп)	4-700 4-700	95,6 (11,0)	95,6 (11,0)	95,6 (11,0)	95,6 (11,0)	95,6 (11,0)	86,2 (10,0)	86,9 (10,0)	



[Key for Appendix 2]:

1. Unit of measurement; 2. Frequency, KHz; 3. KNK-6; 4. KNK-6T; 5. KSPP(V) 1x4x0.8; KSPPB(K) 1x4x0.9; 6. IKM-12M; 7. KSPP(V) 1x4x0.9, KSPPB(K) 1x4x0.9; 8. Circuit resistance at a temperature of +20° C, no greater than;; 9. Difference in the resistances of the circuit cores, no greater than;; 10. Insulation resistance between each core and the steel cores connected to the ground shield, no less than;; 11. Insulation resistance of the shield with respect to ground, no less than;; 12. Working capacitance, no more than;; 13. Electrical strength of the insulation between all connected cores and the shield, between the bundle of "a" cores and "b" cores of physical circuits, no less than;; 14. Near end crosstalk attenuation between circuits, no less than;; 15. Far end isolation between physical circuits, no less than;; 16. Crosstalk attenuation between the input an output of one multiplexed circuit in a NUP or OUP, no less than;; 17. Near end imbalance in a physical circuit, no less than;; 18. Line interference (noise) of a physical circuit over the spectral width of one channel, no more than;; 19. Without a NUP - 56.5 (6.5); [with] 1 NUP - 59.1 (6.8); 2 NUP's - 60.8 (7.0); 3 NUP's and 1 OUP - 63.4 (7.3); 4 NUP's and 1 OUP - 64.1 (7.4); 20. Without a NUP - 56.5 (6.5); [with] 1 NUP - 59.1 (6.8); 21. NUP - 60.8 (7.0); OUP - 78.2 (9.0).

### APPENDIX 3

#### OPERATIONAL ENGINEERING NORMS FOR THE ELECTRICAL CHARACTERISTICS OF INSTALLED (EXISTING) RURAL TELEPHONE COMMUNICATIONS LINES

##### Insulation Resistance

1. The insulation resistance of 1 Km of open wire with respect to ground during damp weather (100% relative air humidity) is no less than 2 MOhms·Km for inter-exchange junction lines and for subscriber lines. The insulation resistance between circuit conductors should be approximately equal to the sum of the insulation resistances of both conductors of the line with respect to ground. A difference in the magnitude of the insulation resistance of the conductors of an open wire circuit with respect to ground should not exceed 30%.

2. The insulation resistance of the cores of single pair cables of the PRVPM type with polyvinylchloride insulation and the PRPPM type with polyethylene insulation, with respect to ground, is no less than 3 MOhms·Km. The insulation resistance between the cable cores is no less than 6 MOhms·Km.

3. The insulation resistance of the cores of multipair cables of the T, TPP, TPKSh, TPKSh-B and TPKSh-Z types, with respect to all the remaining cores connected to the jacket (shield) of the cable and ground, should be no less than the following at a temperature of +20° C:

-- For interexchange cable lines and the cables of junction lines for lengths of 0.5 Km and more, 1,000 MOhms·Km;

- For line lengths of up to 0.5 KM, 500 MOhms·Km.
- For a distribution cable, over the entire length of the cable, 50 MOhms.

4. The insulation resistance of the cores of a single quadded KSPV cable, and a multiquadded TZ cable, with respect to the remaining cores, which are connected to the shield and ground, should be no less than 10,000 MOhms·Km, while for a single quadded MKPV cable, no less than 15,000 MOhms·Km.

5. The insulation resistance of cores with respect to ground of a subscriber wire should be no less than 25 MOhms·Km over the entire length of the line.

The Difference in the DC Resistances (Imbalance) of the Conductors (Cores) of a Circuit.

1. The circuit imbalance of subscriber open wire and cable lines should be no more than 1 % of the circuit resistance.
2. The imbalance in interexchange junction open wire lines both multiplexed and unmultiplexed, over the length of the line between terminal stations (without amplifier stations) or over an amplified section, should be no more than 5 ohms for steel conductors with a diameter of 4 mm, and 10 ohms for conductors of diameters of 2.5 and 3 mm.
3. The imbalance in interexchange junction lines made of cables of any type, both multiplexed and unmultiplexed, should be no more than 2 ohms for physical and phantom circuits.

Near End Crosstalk Attenuation Between Circuits

1. The crosstalk attenuation between any subscriber circuits on a cable line at a frequency of 800 Hz should be no less than 69.5 dB (8 Nep) for 95% of the circuits, and no less than 65 dB (7.5 Nep) for the remaining 5% of the line circuits.
2. The crosstalk attenuation between open wire line subscriber circuits at a frequency of 800 Hz should be no less than 69.5 dB (8.0 Nep).
3. The crosstalk attenuation between unmultiplexed, interexchange junction lines at a frequency of 800 Hz should be no less than 69.5 dB (8 Nep).
4. The crosstalk attenuation between multiplexed circuits on interexchange junction lines between two terminal stations (without amplifier stations) or for an amplified section in a multiplex passband of 4 - 31 KHz for open wire and 8 - 700 KHz for cable lines, should be no less than 60.8 dB (7.0 Nep).

The Far End Isolation Between Circuits

1. The isolation on a length of cable line between terminal points (without amplifier stations) or over an amplified section, between multiplexed circuits

at the far end of a cable in a frequency spectrum of 4 - 31 KHz, when using the V-3-3S and VO-3-4 equipment, should be no less than 56.5 - 65 dB (6.5 - 7.5 Nep). This quantity is determined by the number of amplified sections.

2. The far end isolation between the circuits of a cable line within a frequency range of 4 - 120 KHz when using the KNK-6S, KNK-6SM, KNK-6T and KNK-12 equipment, should be no less than 60.8 dB (7 Nep) with seven amplified sections. For IKM-12M equipment in a frequency range of 8 - 700 KHz, it should be no less than 43.4 dB (5.0 Nep).

3. The isolation between circuits at the far end of open wire communications lines within a frequency passband of 4 - 31 KHz should be no less than 56.5 dB (6.5 Nep).

#### The Lengthwise Imbalance Attenuation of a Circuit at the Near End of the Line

The lengthwise imbalance attenuation of a circuit at the near end of subscriber, interexchange, and junction lines for both multiplexed and unmultiplexed lines, should be no less than 65 dB (7.5 Nep) in a frequency passband of 0.3 - 3.4 KHz, and 43.5 dB (5 Nep) in a range of 4 - 700 KHz.

#### Line Noise

1. The level of psophometric noise should be no more than 5 millivolts on interexchange, junction unmultiplexed open wire or cable lines, which are not equipped with terminal audio frequency amplifiers. Lines, equipped with terminal amplifiers, should have no more than 2.5 millivolts.

2. The noise on subscriber lines, measured at the terminals of the telephone set in a frequency range of 0.3 - 3.4 KHz, should be no more than 1.0 mV.

3. The psophometric noise voltage in a frequency passband of 0.3 - 3.4 KHz at the terminals of the telephone set, which is induced in the open wire line telephone circuits of rural networks by power lines (electrified railroad, electrical power transmission lines, etc.), on the section from the subscriber to the distribution frame of the telephone exchange for the case of a local connection, should not exceed 0.5 millivolts.

In individual cases, if observing the indicated norm results in high costs, an increase in the noise up to 2 millivolts is permitted with the permission of the Communications Ministry of the union republic.

4. The overall noise voltage in the frequency passband of one multiplex channel on open wire steel circuits in a line spectrum of 4 - 31 KHz, should be no less than 78.2 dB (9 Nep).

5. The overall noise voltage in the frequency passband of one channel on cable lines in a line spectrum of 4 - 120 KHz should correspondingly be no less than 95.6 dB (11 Nep).

Table P.4.1. The Electrical Characteristics of Single Pair Cables at a Temperature of +20° C.

Таблица П.4.1  
ЭЛЕКТРИЧЕСКИЕ ХАРАКТЕРИСТИКИ КАБЕЛЕЙ ПРИ ТЕМПЕРАТУРЕ +20°С

Type of Cable	1. Сопротивление потока, Ом/км	2. Сопротивление изоляции жил, не менее Мом.км	3. Рабочая емкость цепи, не более дкФ/км	4. Испытательное напряжение на частоте 50 Гц, не менее В. эфф	5. Коэфф. затухания на частоте 800 Гц не более дБ/км (Нп/км)	6. Модуль волнового сопротивления на частоте 800 Гц, Ом
PRVPM	33,4	10	0,116	8000	0,85(0,096)	237
PRVPM	47,8	10	0,114	2000	1,00(0,115)	290
PRVPM	75,2	10	0,111	2000	1,24(0,143)	353
PRPPM	31,6	100	0,070	4000	0,56(0,061)	360
PRPPM	45,6	100	0,060	4000	0,63(0,072)	443
PRPPM	71,0	100	0,055	4000	0,72(0,083)	580
PTVZh	140	10	—	500	—	—
PTVZh	280	10	—	500	—	—
"	1200	10	—	500	—	—
PTPZh	140	60	—	500	—	—
"	280	60	—	500	—	—
"	1200	60	—	500	—	—
TRV-0,5	190	25	—	2000	—	—
ATRV-0,7	160	»	—	»	—	—
TRP-0,5	190	100	—	»	—	—
ATRP-0,7	160	»	—	»	—	—

Key: 1. DC resistance, no greater than, Ohms/Km; 2. Insulation resistance of the cores, no less than, MOhms·Km; 3. Working circuit capacitance, no more than, microfarads/Km; 4. Test voltage at a frequency of 50 Hz, no less than, eff. Volts; 5. Attenuation factor at 800 Hz, no greater than, dB/Km (Nep/Km); 6. Absolute value of the characteristic impedance at 800 Hz, ohms.

TABLE P.4.2. The Electrical Characteristics of Multipair Cables at a Temperature of +20° C

ЭЛЕКТРИЧЕСКИЕ ХАРАКТЕРИСТИКИ МНОГОПАРНЫХ КАБЕЛЕЙ ПРИ ТЕМПЕРАТУРЕ +20°С

Type of Cable	Диаметр жил, мм	Сопротивление цепи питания, Ом/км	Сопротивление изоляции жил, не менее Мом·км	Рабочая емкость цепи, не более, мкФ/км	Испытательное напряжение между жилами перем. тока частотой 50 Гц, не менее, В.эфф.	Кэфф. затухания на частоте 800 Гц, не более дБ/км(НП/км)	Модуль волнового сопротив. на частоте 800 Гц, Ом
Тип кабеля	1.	2.	3.	4.	5.	6.	7.
ТРР(V), ТРРV, ТППВ, ТППВ	0,4	296	5000	0,05	5·500/500	1,44(0,166)	1140
	0,5	190	5000	0,05	500/500	1,20(0,138)	940
	0,7	97	5000	0,042	500/500	0,79(0,091)	700
ТПКШ ТПКШh	0,5	190	2000	0,05	500/500	1,21(0,140)	889
	0,4	296	5000	0,045	500/500	1,52(0,175)	1136
ТПКШ-3 ТПКШh-3	0,5	186	5000	0,05	1000/1000	1,13(0,130)	934
	0,4	296	2000	0,05	500/500	1,61(0,185)	972
ТГ, ТВ, ТК ТГ, ТВ, ТК	0,5	190	2000	0,05	500/500	1,26(0,145)	869
	0,7	96	2000	0,042	5 0/500	0,83(0,095)	691
	0,8	72,2	10000	0,033	700/1000	0,64(0,074)	648
ТЗ, ТЗВ, ТЗК ТЗ, ТЗВ, ТЗК	0,9	57,0	10000	0,034	700/1000	0,57(0,066)	588
	1,0	45,6	10000	0,034	700/1000	0,51(0,059)	510
	1,2	32,8	10000	0,035	1000/1800	0,43(0,050)	424
	1,4	23,8	10000	0,036	1000/1800	0,37(0,043)	366

Примечание. В числителе указывается испытательное напряжение между жилами, в знаменателе — между жилами и экраном или металлической оболочкой.

Note: Given in the numerator is the test voltage between the cores, and in the denominator, the voltage between the cores and the shield or the metal jacket.

Key: 1. Diameter of the cores, mm; 2. DC resistance of the circuit, no more than, Ohms/Km; 3. Insulation resistance of the cores, no less than, MOhms·Km; 4. Working circuit capacitance, no more than, microfarads/Km; 5. Test voltage between the cores using AC at 50 Hz, no less than, eff. volts; 6. Attenuation factor at 800 Hz, no more than, dB/Km (Nep/Km); 7. Absolute value of the characteristic impedance at 800 Hz, ohms.

TABLE P.4.3. The Frequency Characteristics of Single Quadded Cable Circuits at a Temperature of +20° C

Таблица П.4.3  
ЧАСТОТНЫЕ ХАРАКТЕРИСТИКИ ЦЕПЕЙ ОДНОЧЕТВЕРЧНЫХ КАБЕЛЕЙ ПРИ ТЕМПЕРАТУРЕ +20°С

Частота, кГц Frequency, kHz	VTSP (V) ВТСП(В) 1x4x1,2						МКРВ МКПВ 1x4x1,2						
	Основные цепи 1.			Основные цепи 2.			Основные цепи 1			Основные цепи 2.			
	Кoeffициент затухания, дБ/км (Нп/км)	Модуль волнового сопротивления, Ом	температурный коэффициент затухания 10 <sup>-3</sup> /°С	Кoeffициент затухания, дБ/км (Нп/км)	Модуль волнового сопротивления, Ом	температурный коэффициент затухания 10 <sup>-3</sup> /°С	Кoeffициент затухания, дБ/км (Нп/км)	Модуль волнового сопротивления, Ом	температурный коэффициент затухания 10 <sup>-3</sup> /°С	Кoeffициент затухания, дБ/км (Нп/км)	Модуль волнового сопротивления, Ом	температурный коэффициент затухания 10 <sup>-3</sup> /°С	
0,3	0,54(0,062)	360,0	3,51	0,34(0,04)	165,0	—	0,62(0,071)	536,5	0,43(0,05)	410,0	—	0,49(0,057)	178,0
0,8	0,59(0,068)	333,8	3,49	0,71(0,082)	154,0	—	0,71(0,082)	492,6	0,51(0,059)	358,5	—	0,61(0,070)	152,5
1,5	0,62(0,072)	320,0	3,47	0,79(0,091)	141,0	—	0,78(0,090)	441,2	0,57(0,056)	378,3	—	0,68(0,079)	134,3
3,0	0,70(0,081)	282,2	3,44	0,88(0,101)	91,0	—	0,92(0,106)	398,5	0,68(0,079)	232,0	—	0,88(0,098)	98,0
3,4	0,72(0,090)	267,2	3,43	0,91(0,105)	87,0	—	0,97(0,112)	373,4	0,70(0,081)	214,9	—	0,87(0,109)	94,4
5,0	0,85(0,103)	207,0	3,38	1,03(0,119)	70,0	—	1,18(0,137)	273,1	0,77(0,089)	196,0	—	0,94(0,103)	80,0
10	1,09(0,126)	165,0	3,35	1,11(0,128)	63,0	—	1,50(0,175)	180,7	0,80(0,092)	170,0	—	0,97(0,112)	77,2
30	1,71(0,198)	132,0	3,25	1,18(0,137)	57	—	2,12(0,245)	149,2	1,10(0,127)	157,0	—	1,10(0,137)	65,0
60	2,26(0,260)	125,0	3,07	—	—	—	2,60(0,297)	141,8	1,39(0,160)	150,0	—	—	—
100	2,82(0,325)	120,0	2,76	—	—	—	2,62(0,302)	137,9	1,80(0,208)	145,0	—	—	—
108	2,90(0,335)	120,0	2,74	—	—	—	2,88(0,332)	137,0	1,83(0,213)	144,5	—	—	—
120	3,04(0,350)	120,0	2,70	—	—	—	3,27(0,378)	136,0	1,91(0,231)	144,0	—	—	—
150	3,34(0,385)	118,0	2,66	—	—	—	3,52(0,406)	135,3	—	—	—	—	—
200	3,50(0,403)	117,0	2,59	—	—	—	3,93(0,453)	134,1	—	—	—	—	—
250	3,92(0,452)	116,5	2,52	—	—	—	4,34(0,500)	132,9	—	—	—	—	—
300	4,35(0,501)	116,0	2,45	—	—	—	4,75(0,546)	131,8	—	—	—	—	—
350	4,69(0,540)	115,8	2,42	—	—	—	5,10(0,586)	131,0	—	—	—	—	—
400	4,87(0,562)	115,8	2,39	—	—	—	5,40(0,625)	130,0	—	—	—	—	—
500	5,65(0,654)	114,0	2,32	—	—	—	6,55(0,729)	129,8	—	—	—	—	—
600	5,82(0,674)	113,8	2,30	—	—	—	6,55(0,755)	129,6	—	—	—	—	—
700	6,25(0,720)	113,5	2,25	—	—	—	7,05(0,807)	129,0	—	—	—	—	—

Key: 1. Physical Circuits; 2. Phantom circuits; 3. KSPV (V) 1x4x0.9; KSPPB(K) 1x4x0.9;  
4. Attenuation factor, dB/Km (Nep/Km); 5. Absolute value of the characteristic impedance, ohms; 6. Temperature coefficient of attenuation, 10<sup>-3</sup>/°C.

APPENDIX 5

THE ELECTRICAL CHARACTERISTICS OF OPEN WIRE COMMUNICATIONS LINES

TABLE P.5.1. The Frequency Characteristics of Two Wire Steel Circuits With Diameters of 1.5 and 2 mm  
(Humid, temperature +20° C)

Т а б л и ц а П.5.1

ЧАСТОТНЫЕ ХАРАКТЕРИСТИКИ ДВУХПРОВОДНЫХ СТАЛЬНЫХ ЦЕПЕЙ  
С ДИАМЕТРОМ 1,5 и 2 мм  
(Сыро, температура +20°С)

1. Частота кГц	2. Коэффициент затухания, дБ/км (Нп/км)	3. Модуль волнового сопротивления, Ом	4. Коэффициент затухания, дБ/км (Нп/км)	5. Модуль волнового сопротивления, Ом
$a=20$ см				
0,3	0,237 (0,0273)	4100	0,178 (0,0205)	3084
0,8	0,347 (0,0400)	2640	0,252 (0,0290)	2130
2,0	0,498 (0,0573)	1990	0,412 (0,0474)	1695
5,0	0,912 (0,1050)	1620	0,742 (0,0854)	1380
$a=36$ см				
0,3	0,220 (0,0253)	4330	0,166 (0,0191)	3243
0,8	0,330 (0,0380)	2795	0,237 (0,0273)	2245
2,0	0,472 (0,0543)	2096	0,387 (0,0445)	1796
5,0	0,830 (0,0955)	1706	0,697 (0,0803)	1460

- Key:
1. Frequency, KHz;
  2. Attenuation factor, dB/Km (Nep/Km);
  3. Absolute value of the characteristic impedance, ohms;
  4. Attenuation factor, dB/Km (Nep/Km);
  5. Absolute value of the characteristic impedance, ohms.

TABLE P.5.2. The Parameters of Open Wire Line Circuits for Alternating Current (Summer, Humid,  $t = +20^{\circ} \text{C}$ )

Материалы и диаметр 1. проводов цепи	Частота кГц 2.	R Ом/км 3.	G мксм км 4.	5. C, вФ/км						7. $\alpha$ , дБ/км (НП/км)						9. $ Z_B $ , Ом						$-\varphi_7^0$
				10. при расстоянии между проводами, см						10. при расстоянии между проводами, см						10. при расстоянии между проводами, см						
				20	60	20	60	20	60	20	60	20	60	20	60	20	60	20	60	20	60	
Steel Сталь 3 мм	0.8	58.4	0.7	5.98	4.89	11.2	11.6	19.7	17.9	45	41	1640	1830	22°21'	21°35'							
	10	182.0	3.0	5.98	4.89	4.7	5.1	(0.1711)	(0.1555)	357	326	864	1100	15°32'	14°07'							
	30	306.0	8.0	5.98	4.89	3.5	4.0	(0.8608)	(0.7592)	887	850	938	12°07'	10°50'								
Steel Сталь 4 мм	0.8	42.2	0.7	6.35	5.14	9.0	9.6	15.0	14.9	41	37.5	1390	1570	20°53'	20°05'							
	10	134.0	3.0	6.35	5.14	3.9	4.3	(0.1303)	(0.1294)	322	304	835	970	14°12'	12°54'							
	30	228.0	8.0	6.35	5.14	3.0	3.5	(0.7340)	(0.6289)	839	804	716	844	10°43'	9°26'							
Copper Медь 4 мм	0.8	2.9	0.7	6.35	5.14	1.9	2.4	2.8	2.3	18	17	563	690	7°35'	6°01'							
	10	5.0	3.0	6.35	5.14	1.9	2.3	(0.0243)	(0.01998)	221	221	550	674	0°58'	—							
	30	8.1	8.0	6.35	5.14	1.9	2.3	(0.0469)	(0.0408)	661	661	544	670	0°27'	—							
	150	17.2	38.0	6.35	5.14	1.9	2.3	(0.0834)	(0.0756)	3290	3240	542	667	—	—							
Bimetal Биметалл BSM-2 4 мм	0.8	12.3	0.7	5.65	4.66	1.9	2.4	9.9	8.5	20	19	700	805	25°	—							
	10	13.6	3.0	5.65	4.66	1.9	2.3	(0.0860)	(0.0738)	217	216	547	674	3°	—							
	30	15.0	8.0	5.65	4.66	1.9	2.3	(0.1129)	(0.0964)	648	647	544	672	—	—							
	150	23.6	38.0	5.65	4.66	1.9	2.3	(0.1381)	(0.1199)	3233	3235	542	670	—	—							

Key: 1. Materials and diameter of the circuit conductors; 2. Frequency, KHz; 3. R, ohms/Km; 4. G, micromhos/Km; 5. C, nanofarads/Km; 6. L, millihenries/Km; 7.  $\alpha$ , dB/Km (Nep/Km); 8.  $\beta$ , milliradians/Km; 9.  $|Z_0|$ , ohms; 10. For a spacing between the conductors of, cm.



TABLE P.5.3. The Frequency Characteristics of Open Wire Communications Line Steel Circuits

Таблица П.5.3

ЧАСТОТНЫЕ ХАРАКТЕРИСТИКИ СТАЛЬНЫХ ЦЕПЕЙ ВОЗДУШНЫХ ЛИНИЙ СВЯЗИ

Частота, КГц	2. Коэффициент затухания, дБ/км (Нп/км), при						Модуль волнового сопротивления Ом
	сухо +20°C		сухо -20°C		средней толщине слоя, мм		
	сухо +20°C	сыро +20°C	сухо -20°C	сыро -20°C	3. средняя толщине слоя, мм	5. изморози rime ice	
	3. средняя толщине слоя, мм						
	4. гололеда		5		12		
	5. изморози rime ice						
	6. гололеда						
	7. изморози rime ice						
	8. гололеда						
	9. изморози rime ice						
	10. гололеда						
	11. изморози rime ice						
	12. гололеда						
	13. изморози rime ice						
	14. гололеда						
	15. изморози rime ice						
	16. гололеда						
	17. изморози rime ice						
	18. гололеда						
	19. изморози rime ice						
	20. гололеда						
	21. изморози rime ice						
	22. гололеда						
	23. изморози rime ice						
	24. гололеда						
	25. изморози rime ice						
	26. гололеда						
	27. изморози rime ice						
	28. гололеда						
	29. изморози rime ice						
	30. гололеда						
	31. изморози rime ice						
	32. гололеда						
	33. изморози rime ice						
	34. гололеда						
	35. изморози rime ice						
	36. гололеда						
	37. изморози rime ice						
	38. гололеда						
	39. изморози rime ice						
	40. гололеда						
	41. изморози rime ice						
	42. гололеда						
	43. изморози rime ice						
	44. гололеда						
	45. изморози rime ice						
	46. гололеда						
	47. изморози rime ice						
	48. гололеда						
	49. изморози rime ice						
	50. гололеда						
	51. изморози rime ice						
	52. гололеда						
	53. изморози rime ice						
	54. гололеда						
	55. изморози rime ice						
	56. гололеда						
	57. изморози rime ice						
	58. гололеда						
	59. изморози rime ice						
	60. гололеда						
	61. изморози rime ice						
	62. гололеда						
	63. изморози rime ice						
	64. гололеда						
	65. изморози rime ice						
	66. гололеда						
	67. изморози rime ice						
	68. гололеда						
	69. изморози rime ice						
	70. гололеда						
	71. изморози rime ice						
	72. гололеда						
	73. изморози rime ice						
	74. гололеда						
	75. изморози rime ice						
	76. гололеда						
	77. изморози rime ice						
	78. гололеда						
	79. изморози rime ice						
	80. гололеда						
	81. изморози rime ice						
	82. гололеда						
	83. изморози rime ice						
	84. гололеда						
	85. изморози rime ice						
	86. гололеда						
	87. изморози rime ice						
	88. гололеда						
	89. изморози rime ice						
	90. гололеда						
	91. изморози rime ice						
	92. гололеда						
	93. изморози rime ice						
	94. гололеда						
	95. изморози rime ice						
	96. гололеда						
	97. изморози rime ice						
	98. гололеда						
	99. изморози rime ice						
	100. гололеда						

Key: 1. Frequency, KHz; 2. Attenuation factor, dB/Km (Nep/Km), for the following conditions;;  
 3. An average layer thickness, in mm; 4. Of ice crust; 5. The absolute value of the characteristic impedance, ohms.

TABLE P.5.3. [Continued] The Frequency Characteristics of Open Wire Communications Line Steel Circuits

Продолжение табл. П.5.3

Частота, кГц	2. Коэффициент затухания, дБ/км (Нп/км), при						3. средней толщине слоя, мм	наморози rime	Модуль вол-нового сопро-тивления, Ом
	сухо +20°C		сухо -20°C		4. гололеда				
	dry	damp	dry	dry	5	12			
10.0	0.745(0.0858)	0.759(0.0874)	0.691(0.0795)	0.725(0.0835)	0.730(0.0841)	0.732(0.0843)	1100	0.732(0.0843)	
15.0	0.955(0.1100)	0.976(0.1124)	0.887(0.1021)	0.939(0.1081)	0.949(0.1092)	0.952(0.1096)	1037	0.952(0.1096)	
20.0	1.147(0.1320)	1.171(0.1348)	0.948(0.1207)	1.127(0.1297)	1.144(0.1317)	1.149(0.1323)	982	1.149(0.1323)	
30.0	1.464(0.1685)	1.485(0.1710)	1.339(0.1542)	1.477(0.1700)	1.512(0.1741)	1.523(0.1753)	938	1.523(0.1753)	
40.0	1.720(0.198)	1.746(0.2010)	1.580(0.1819)	1.755(0.2020)	1.815(0.2090)	1.834(0.2111)	910	1.834(0.2111)	
$d=4$ мм, $\sigma=20$ см									
0.3	0.076(0.0086)	0.081(0.0093)	0.072(0.0083)	0.075(0.0086)	0.075(0.0086)	0.075(0.0086)	1740	0.075(0.0086)	
0.8	1.141(0.0162)	0.146(0.0168)	0.130(0.0150)	0.136(0.0156)	0.136(0.0156)	0.136(0.0156)	1390	0.136(0.0156)	
2.0	0.255(0.0294)	0.265(0.0305)	0.235(0.0270)	0.246(0.0283)	0.246(0.0283)	0.246(0.0283)	1133	0.246(0.0283)	
3.0	0.834(0.0384)	0.339(0.0390)	0.301(0.0347)	0.319(0.0367)	0.319(0.0367)	0.319(0.0367)	1043	0.319(0.0367)	
5.0	0.461(0.0531)	0.467(0.0538)	0.433(0.0498)	0.450(0.0518)	0.451(0.0519)	0.452(0.0520)	944	0.452(0.0520)	
7.0	0.573(0.0660)	0.578(0.0665)	0.530(0.0617)	0.560(0.0645)	0.562(0.0647)	0.563(0.0648)	865	0.563(0.0648)	
10.0	0.721(0.0830)	0.734(0.0845)	0.668(0.0766)	0.703(0.0809)	0.708(0.0815)	0.710(0.0817)	835	0.710(0.0817)	
15.0	0.929(0.1070)	0.942(0.1085)	0.864(0.0995)	0.918(0.1057)	0.929(0.1069)	0.932(0.1073)	784	0.932(0.1073)	
20.0	1.103(0.1270)	1.120(0.1290)	1.020(0.1175)	1.098(0.1264)	1.115(0.1284)	1.120(0.1290)	755	1.120(0.1290)	
30.0	1.407(0.1620)	1.433(0.1650)	1.299(0.1495)	1.429(0.1645)	1.464(0.1685)	1.477(0.1700)	716	1.477(0.1700)	
40.0	1.668(0.1920)	1.694(0.1950)	1.530(0.1762)	1.729(0.1991)	1.795(0.2067)	1.819(0.2094)	694	1.819(0.2094)	
$d=4$ мм, $\sigma=60$ см									
3.0	0.069(0.0079)	0.073(0.0084)	0.070(0.0084)	0.066(0.0076)	0.066(0.0076)	0.066(0.0076)	1950	0.066(0.0076)	
0.8	0.125(0.0144)	0.129(0.0148)	0.116(0.0133)	0.120(0.0138)	0.120(0.0138)	0.121(0.0139)	1575	0.121(0.0139)	

TABLE P.5.3. [Continued] The Frequency Characteristics of Open Wire Communications Line Steel Circuits

Продолжение табл. П.5.3

1. Частота, КГц	2. Коэффициент затухания, дБ/км (Нп/км), при										3. средняя толщина слоя, мм	изморозь fime	4. номер в последовательности
	сухо +20°C		сыро +20°C damp		сухо -20°C dry		4. гололеда						
	dry	dry	damp	damp	dry	dry	5	12	12				
2.0	0.221(0.0255)	0.225(0.0259)	0.225(0.0259)	0.225(0.0259)	0.202(0.0232)	0.212(0.0244)	0.212(0.0244)	0.212(0.0244)	0.212(0.0244)	0.212(0.0244)	0.212(0.0244)	0.212(0.0244)	1283
3.0	0.295(0.0340)	0.296(0.0341)	0.296(0.0341)	0.296(0.0341)	0.262(0.0302)	0.280(0.0322)	0.280(0.0322)	0.280(0.0322)	0.280(0.0322)	0.280(0.0322)	0.280(0.0322)	0.280(0.0322)	1189
5.0	0.408(0.0470)	0.413(0.0476)	0.413(0.0476)	0.413(0.0476)	0.375(0.0432)	0.396(0.0456)	0.396(0.0456)	0.396(0.0456)	0.396(0.0456)	0.396(0.0456)	0.396(0.0456)	0.396(0.0456)	1085
7.0	0.493(0.0568)	0.505(0.0581)	0.505(0.0581)	0.505(0.0581)	0.456(0.0525)	0.487(0.0561)	0.487(0.0561)	0.487(0.0561)	0.487(0.0561)	0.487(0.0561)	0.487(0.0561)	0.487(0.0561)	1028
10.0	0.617(0.0710)	0.629(0.0724)	0.629(0.0724)	0.629(0.0724)	0.568(0.0654)	0.599(0.0690)	0.599(0.0690)	0.599(0.0690)	0.599(0.0690)	0.599(0.0690)	0.599(0.0690)	0.599(0.0690)	970
15.0	0.799(0.0920)	0.812(0.0935)	0.812(0.0935)	0.812(0.0935)	0.734(0.0845)	0.781(0.0899)	0.781(0.0899)	0.781(0.0899)	0.781(0.0899)	0.781(0.0899)	0.781(0.0899)	0.781(0.0899)	914
20.0	0.929(0.01070)	0.962(0.1108)	0.962(0.1108)	0.962(0.1108)	1.896(0.0994)	0.929(0.1070)	0.929(0.1070)	0.929(0.1070)	0.929(0.1070)	0.929(0.1070)	0.929(0.1070)	0.929(0.1070)	884
30.0	1.190(0.1370)	1.216(0.1400)	1.216(0.1400)	1.216(0.1400)	1.086(0.1250)	1.194(0.1375)	1.194(0.1375)	1.194(0.1375)	1.194(0.1375)	1.194(0.1375)	1.194(0.1375)	1.194(0.1375)	844
40.0	1.407(0.1620)	1.442(0.1660)	1.442(0.1660)	1.442(0.1660)	1.279(0.1473)	1.429(0.1645)	1.429(0.1645)	1.429(0.1645)	1.429(0.1645)	1.429(0.1645)	1.429(0.1645)	1.429(0.1645)	821
$d=5$ мм, $d=20$ см													
0.3	0.967(0.0077)	0.069(0.0080)	0.069(0.0080)	0.069(0.0080)	0.062(0.0071)	0.064(0.0074)	0.064(0.0074)	0.064(0.0074)	0.064(0.0074)	0.064(0.0074)	0.064(0.0074)	0.064(0.0074)	1539
0.8	0.126(0.0144)	0.129(0.0148)	0.129(0.0148)	0.129(0.0148)	0.117(0.0135)	0.122(0.0140)	0.122(0.0140)	0.122(0.0140)	0.122(0.0140)	0.122(0.0140)	0.122(0.0140)	0.122(0.0140)	1225
2.0	0.226(0.0260)	0.231(0.0256)	0.231(0.0256)	0.231(0.0256)	0.213(0.0245)	0.221(0.0254)	0.221(0.0254)	0.221(0.0254)	0.221(0.0254)	0.221(0.0254)	0.221(0.0254)	0.221(0.0254)	1005
3.0	0.296(0.0341)	0.301(0.0346)	0.301(0.0346)	0.301(0.0346)	0.277(0.0316)	0.287(0.0330)	0.287(0.0330)	0.287(0.0330)	0.287(0.0330)	0.287(0.0330)	0.287(0.0330)	0.287(0.0330)	921
5.0	0.408(0.0470)	0.415(0.0478)	0.415(0.0478)	0.415(0.0478)	0.382(0.0440)	0.398(0.0458)	0.398(0.0458)	0.398(0.0458)	0.398(0.0458)	0.398(0.0458)	0.398(0.0458)	0.398(0.0458)	845
7.0	0.512(0.0590)	0.512(0.0590)	0.512(0.0590)	0.512(0.0590)	0.471(0.0542)	0.499(0.0574)	0.499(0.0574)	0.499(0.0574)	0.499(0.0574)	0.499(0.0574)	0.499(0.0574)	0.499(0.0574)	792
10.0	0.631(0.0726)	0.643(0.0740)	0.643(0.0740)	0.643(0.0740)	0.578(0.0665)	0.622(0.0716)	0.622(0.0716)	0.622(0.0716)	0.622(0.0716)	0.622(0.0716)	0.622(0.0716)	0.622(0.0716)	750
15.0	0.808(0.0930)	0.819(0.0943)	0.819(0.0943)	0.819(0.0943)	0.740(0.0852)	0.803(0.0924)	0.803(0.0924)	0.803(0.0924)	0.803(0.0924)	0.803(0.0924)	0.803(0.0924)	0.803(0.0924)	715
20.0	0.968(0.1115)	0.982(0.1130)	0.982(0.1130)	0.982(0.1130)	0.895(0.1030)	0.960(0.1105)	0.960(0.1105)	0.960(0.1105)	0.960(0.1105)	0.960(0.1105)	0.960(0.1105)	0.960(0.1105)	688

TABLE P.5.3. [Conclusion] The Frequency Characteristics of Open Wire Communications Line Steel Circuits

Продолжение табл. П.5.3

Частота, кГц 1.	2. Коэффициент затухания, дБ/км (Нп/км), при				3. средняя толщина слоя, мм			Модуль волн. нового сопро- твления, Ом 5.
	сухо +20°C dry	сыро +20°C damp	сухо -20°C dry	заморожен -20°C frozen	4. гололеда		rime	
					5	12		
30.0	1,220(0,1405)	1,242(0,1430)	1,116(0,1285)		1,225(0,1410)	1,267(0,1459)	1,230(0,1474)	658
40.0	1,459(0,1630)	1,477(0,1700)	1,327(0,1528)		1,484(0,1709)	1,557(0,1792)	1,579(0,1818)	637
$d=5 \text{ мм}, a=60 \text{ см}$								
0.3	0,058(0,0067)	0,067(0,0072)	0,055(0,0063)		0,055(0,0065)	0,056(0,0065)	0,056(0,0065)	1729
0.8	0,110(0,0127)	0,113(0,0130)	0,100(0,0115)		0,105(0,0121)	0,105(0,0121)	0,105(0,0121)	1390
2.0	0,197(0,0227)	0,202(0,0232)	0,184(0,0212)		0,190(0,0219)	0,191(0,0220)	0,191(0,0220)	1145
3.0	0,285(0,0294)	0,261(0,0300)	0,236(0,0272)		0,247(0,0284)	0,247(0,0284)	0,247(0,0284)	1072
5.0	0,351(0,0404)	0,355(0,0409)	0,325(0,0374)		0,340(0,0391)	0,340(0,0392)	0,341(0,0393)	979
7.0	0,431(0,0496)	0,439(0,0505)	0,400(0,0461)		0,420(0,0483)	0,420(0,0484)	0,421(0,0485)	936
10.0	0,535(0,0616)	0,546(0,0629)	0,505(0,0581)		0,526(0,0605)	0,530(0,0610)	0,530(0,0610)	884
15.0	0,680(0,0783)	0,693(0,0798)	0,628(0,0723)		0,669(0,0770)	0,678(0,0780)	0,680(0,0783)	844
20.0	0,810(0,0832)	0,828(0,0853)	0,730(0,0840)		0,796(0,916)	0,808(0,0930)	0,810(0,0933)	815
30.0	1,021(0,1175)	1,042(0,1200)	0,914 (0,1052)		1,012(0,1165)	1,042(0,1200)	1,052(0,1211)	785
40.0	1,203(0,1385)	1,235(0,1422)	1,094(0,1260)		1,226(0,1412)	1,282(0,1476)	1,299(0,1496)	763

Key: 1. Frequency, KHz; 2. Attenuation factor, dB/Km (Nep/Km), for the following conditions;;  
 3. An average layer thickness of, in mm; 4. Of ice crust; 5. The absolute value of the characteristic impedance, ohms.

APPENDIX 6.

NORMS FOR THE ELECTRICAL TRANSMISSION CHARACTERISTICS OF TELEPHONE COMMUNICATIONS CHANNELS AND THEIR MEASUREMENT

The Frequency Characteristics of the Residual Channel Attenuation

The maximum distortion in the amplitude-frequency characteristics of communications channels on local communications sections (rural telephone networks), equipped with HF multiplex equipment, should be no greater than the amounts cited in the Table.

TABLE P.6.1. Distortion in the Amplitude-Frequency Response

ИСКАЖЕНИЯ АМПЛИТУДНО-ЧАСТОТНЫХ ХАРАКТЕРИСТИК		
Frequency Полоса частот, Гц passband, Hz	Изменение величины [остаточного затухания относительно его значения на частоте 800 Гц, дБ/Нп]	
	2. превышение	3. снижение
300÷400	(6,94) (0,8)	(1,91) (0,22)
400÷600	(3,90) (0,45)	(1,91) (0,22)
600÷2400	(1,91) (0,22)	(1,91) (0,22)
2400÷3000	(3,90) (0,45)	(1,91) (0,22)
3000÷3400	(6,94) (0,8)	(1,91) (0,22)

- Key: 1. Change in the magnitude of the residual attenuation with respect to its value at 800 Hz, (dB)(Nep);  
 2. Excess response;  
 3. Deficient response.

The frequency characteristics of the residual attenuation of a channel are measured in a four wire termination of the transmission channel at the -13.02 dB (1.5 Nep) and +4.34 dB (0.5 Nep) points in all channels of the HF multiplex system, both with and without the companders.

The transmitting station alternately feeds to the -13.02 dB (1.5 Nep) point of the channel an AC signal from the generator having an output impedance of 600 ohms, at frequencies of 800, 200, 300, 400, 600, 800, 1,200, 1,600, 2,000, 2,400, 2,700, 3,000, 3,400, 3,500, and 800 Hz and a level of -1.5 Nep (13.02 dB), which is monitored by the level meter, the UU.

Using the level meter, UU, with an input impedance of 600 ohms, measured at the receive station at the +4.34 dB (0.5 Nep) point for the KNK-6S and KNK-6T equipment, are the +6.08 (0.7 Nep) receive levels of the corresponding channel.

When several retransmission sections are present on a line, the frequency characteristic of the residual attenuation should be measured over again on each of the retransmission sections, and then for the case of sequential through working for all sections of the line.

The magnitude of the residual attenuation of the channel frequency response at each measured frequency is computed from the formula:

$$a_r = p_{\text{trans}} - p_{\text{rec}} \text{ dB/Nep}$$

where  $p_{\text{trans}}$  is the transmit level at the -13.02 dB (1.5 Nep) point;  
 $p_{\text{rec}}$  is the receive level at the +4.34 dB (0.5 Nep) point.

#### The Amplitude Characteristics of the Channels

The amplitude response makes it possible to determine at which maximum signal level at the input of the channel the sharpest increase in the nonlinear distortion occurs in the channel.

The amplitude response of the channels of HF equipment is measured at 800 Hz at the -1.5 Nep (13.02 dB) and the +0.5 Nep (4.34 dB) points of a four wire channel termination at each retransmission section, and between terminal stations.

When amplitude limiters and companders are present on the HF multiplex equipment channels, the amplitude characteristic of the channel is measured anew when the amplitude limiters and companders are switched out, and then when the amplitude limiters are switched in and the companders are switched out in order to establish the proper operation of the amplitude limiters.

The frequency response of the channel is measured with an 800 Hz generator, two attenuator decades with an input impedance of 600 ohms, and two tone frequency level meters, with inputs balanced with respect to ground. The transmit station feeds through the attenuator decade, the MZ, to the channel input at the -13.02 dB (1.5 Nep) point the following levels, sequentially, at a frequency of 800 Hz: -13.02 (1.5); -21.71 (2.5); -13.02 (-1.5); -11.29 (-1.3); -9.55 (-1.1); -8.68 (-1.0); -7.81 (-0.9); -6.94 (-0.8); -0.7 (-6.08); -0.6 (-5.21) [original text inconsistent]; and -1.5 (13.02) Nep (dB) when the limiters and companders are switched out. With the amplitude limiters switched in and the companders switched out, the signal levels at the input of the channel at the -1.5 (-13.02) point should be: -1.5 (-13.02); -2.5 (-21.71); -1.5 (-13.02); -1.1 (-9.55); -1.0 (-8.68); -0.8 (-6.94); -0.5 (-4.34); -0.3 (-2.60); -0.2 (-1.73); -0.1 (0.86); and -1.5 (-13.02) Nep (dB).

The 600 ohm input impedance level meter at the receive station is connected to the HF system channel being measured at the +0.5 Nep (4.34 dB) point [+0.7 Nep (6.08 dB) for the KNK-6 equipment] through attenuator decade MZ<sub>2</sub>, on which the attenuation should be set so that a receive level is obtained which is suitable for readout on the level meter.

The magnitude of the change in the amplitude characteristic of the channel is computed from the formula:

$$\Delta p = p_{\text{trans}} - p_{\text{rec}}, \text{ Nep (dB)},$$

where  $p_{trans}$  is the transmit level at the -1.5 Nep (-13.02) point;  
 $p_{rec}$  is the receive level at the +0.5 (0.7 Nep) point [4.34 (6.08) dB]  
[sic].

The residual attenuation of the channel for one retransmission section, or between two terminal stations (without retransmission sections) should remain constant within 0.05 Nep (0.43 dB) when the level at the input of the channel is increased from -2.5 Nep (-21.75 dB) to -0.7 Nep (-6.08 dB) when the amplitude limiters and companders are switched out, and from -2.5 Nep (-21.75 dB) up to -1.1 Nep (-9.55 dB) when the amplitude limiters are switched in and the companders are switched out.

The distortion in the amplitude response of the channel when the amplitude limiters and companders are switched in on one retransmission section, should not exceed (1.47 dB) 0.17 Nep.

#### Measuring Noise

The amount of noise in the channel, as a rule, is evaluated by measuring the psophometric noise voltage. In this case, a distinction is drawn between the internal noise of the channel and the overall (total) noise. Internal noise in the channels is measured in the absence of transmission by the HF multiplex equipment on all channels being measured and via channels corresponding in frequency which are used by equipment operating on parallel lines.

The overall channel noise is measured at the peak load hours for the channels used by the HF multiplex equipment being measured, and the equipment operating on parallel lines, and both ends of the channel should be loaded into 600 ohms.

The noise voltage in the channels is measured with a noise meter having an input impedance of 600 ohms which is balanced with respect to ground. The instrument is connected at the terminal (retransmission) stations for HF multiplexing in turn at the (4.34 dB) +0.5 Nep points [at the (6.08 dB) +0.7 Nep point for the KNK-6S1 KNK-6SM and KNK-6T equipment]. In this case, the opposite end of the channel being measured should be loaded into a 600 ohm resistor (when measuring the overall noise).

If the HF multiplex equipment channels are outfitted with compander (noise suppressing) devices, then the noise measurements are performed both with the compander devices switched in and out.

The psophometric noise voltage at the 4.34 (6.0 dB) +0.5 (+0.7) Nep point of the telephone channel, which is measured with a noise meter at the peak load hour for the multiplex equipment for one retransmission section of a line, should not exceed the quantities in Table P.6.2.

For a retransmission section which differs from the norm, the measured amount of noise is multiplied by the factor  $\sqrt{l/l_n}$ , where  $l$  is the length of the retransmission section which exceeds the normal length.

TABLE P.6.2. Psophometric Noise Voltage, millivolts

Relative level at the multiplex equipment points, dB (Nep)	V-2-3 (V-2)	V-3-3S	BO-3-4	KNK-6 S, SM, T	KNK-12	IKM-12M
4.34 (+0.5) (without companders)	5.8	5.8	5.8	-	1.9	1.9
6.08 (+0.7) (without companders)	-	-	-	6.4	-	-
4.34 (+0.5) (with companders)	-	1.42	0.82	0.94	-	-

Note: Climatic conditions:

- For steel open wire line circuits, "summer - humid" at an air temperature of +20° C;
- For cable lines, the ground temperature is +20° C at the burial depth of 0.8 m.

In this case, the overall magnitude of the noise is determined from the formula:

$$U_n = U_{n \text{ nor. sect}} \sqrt{\frac{l}{l_n}} \text{ millivolts}$$

If there are n retransmission sections in a channel, the resulting magnitude of the noise voltage is determined from the formula:

$$U_{\text{ш}} = \sqrt{u_1^2 + u_2^2 + \dots + u_n^2}, \text{ mB,}$$

where  $u_1$ ,  $u_2$  and  $u_n$  are the respective magnitudes of the noise voltage measured at each retransmission section of the channel.

In the absence of a noise meter at the terminal (retransmission) stations, the amount of noise in the channel can be measured (approximately) using a wideband level meter of the UUP-300, IU-600 types, and others. In this case, when the noise is uniformly distributed over the channel spectrum, the psophometric noise voltage is computed from the formula:

$$U_{\text{ш}} = \frac{775e^p}{k}, \text{ mB,}$$

where p is the noise level in nepers measured by the level meter at the (4.34 dB) +0.5 Nep point of the channel;

k is the psophometric factor, equal to 1.33 for channels with an effective transmission passband of 3,100 Hz.

#### The Nonlinear Distortion of a Channel

Nonlinear distortions of a channel are measured at 800 Hz using a S6-1 (INI-12) type instrument.



When organizing the measurement circuitry for the nonlinear distortion of a channel, the magnitude of the nonlinear distortion factor of the measurement generator at 800 Hz and a level of -13.02 dB (-1.5 Nep) is taken into account. The magnitude of the nonlinear distortion factor of the measurement generator should be no more than 0.5%.

If the measurement generator has a nonlinear distortion factor greater than 0.5 %, the measurements are to be carried out using a low frequency filter, which suppresses the harmonics of the primary 800 Hz frequency.

Nonlinear distortions are measured in the four wire part of the channel between the -13.02 (-1.5) and 4.34 (+0.5) dB (Nep) points in both transmission directions, both with and without the companders.

At terminal (retransmission) stations, the multiplex equipment for all channels, other than the one being measured, is loaded into an impedance ohms at the -13.02 (-1.5) and +4.34 (0.5) dB (Nep) points. The 800 Hz generator signals at a level of -13.02 dB (-1.5 Nep), which is monitored on the level meter, the UU, is fed through a low frequency filter to the channel being measured for the transmitting station at the -13.02 dB (-1.5 Nep) point.

The nonlinear distortion of the channel is measured at the receive station at the 4.34 dB (+0.5 Nep) point [at the 6.08 dB (+0.7 Nep) point without the companders for the KNK-6S, KNK-6SM and KNK-6T equipment] using the S6-1 (INI-12) instrument with a 600 ohm input.

During measurements with the S6-1 (INI-12) instrument, the nonlinear distortion factor in the channel is read from the scale of the galvanometer directly in percent. The nonlinear distortion factor in the channel when the amplitude limiters and companders are switched out should be no more than 3% for one retransmission section, and with the use of a compander, no more than 5%. Where there are  $n$  retransmission sections, the nonlinearity factor for the channel should be no more than  $3\sqrt{n}$  and  $5\sqrt{n}$  % respectively.

#### Channel Stability

Any telephone channel, equipped with amplifiers, should be stable against self-excitation under any unfavorable operational conditions that may arise during the operational process.

One of these conditions is the no load mode (open circuit), and for this reason the stability reserve of the telephone channels is checked in the no load mode (open circuit). The stability reserve of a channel is checked both with and without the compander devices in the following sequence.

The channel being tested is set for no load (open circuit) at both ends (with the through working amplifiers inserted at the -6.94 dB (-0.8 Nep) level points). Then wideband level meters, UU's, with a high impedance input or high impedance headsets for monitoring the appearance of oscillation in the channel, are connected to its ends.

After this, the gain of the amplifiers of the tone frequency multiplex equipment is slowly increased in the receive direction at both ends of the channel until the oscillation threshold is reached, which can be heard in headphones or seen by the sharp increase in the readings of the UU level meters, which have shown an insignificant level of noise until this point. The increase in the amplifier gain is stopped at this point.

A signal generator with an output impedance of 600 ohms operating at 800 Hz and a level of 0.0 dB (0.0 Nep), which is monitored by the level meter, the UU, drives the channel being tested at the transmitting station at the -0.8 Nep (-6.94 dB) of the two wire connection of the channel. At the similar point at the receive station of the channel, the generator level is measured using the level meter, the UU, having an input impedance of 600 ohms.

The magnitude of the channel stability reserve,  $\sigma$ , is determined from the formula:

$$\sigma = 0,8(6,94) - \left( \frac{a_1 + a_2}{2} \right), \text{ dB/Hn},$$

where 6.94 (0.8) is the nominal residual attenuation of the channel in dB (Nep);  
 $a_1$  and  $a_2$  are the magnitudes of the residual attenuation in dB (Nep) measured in both transmission directions at the oscillation threshold of the channel.

The magnitude of the channel stability reserve for the HF multiplex equipment in the no load position (open circuit) should be no less than 5.21 dB (0.6 Nep).

When there are three to four retransmission sections present, the stability reserve of the channel, which is determined under the same no load conditions from both ends of the channel, and when the through working pads are switched in, should be no less than 4.34 dB (0.5 Nep).

#### The Isolation Against Audible Crosstalk Conversation Between Channels

The isolation of a channels shows how much weaker the crosstalk conversation level is in the given channel than the level of the useful signal.

For various channels, the magnitude of the isolation fluctuates within rather wide limits, depending on the multiplex equipment, the line installation and the function of the channel. The isolation is evaluated from noise measurement data for the channel, both at its near and far ends at a frequency of 800 Hz.

Measurements of the amount of isolation of the channels are made between the channels of one HF multiplex systems, both at the near and far ends, in four wire terminations of the channels in both transmit directions.

Prior to measuring the isolation magnitudes for the channel, it is necessary to establish the normal transmit levels at the +4.34 dB (0.5 Nep) [for the KNK-6S, KNK-6SM and KNK equipment, +(6.08 dB) 0.7 Nep] and measure the psophometric noise voltage,  $V_n$ , in the channel. In this case, the inputs of the channels at both ends should be loaded into 600 ohms.

Thereafter, the signal generator operating at 800 Hz and a level of -13.02 dB (-1.5 Nep) which is monitored by the level meter, the UU, drives one of the channels (the interfering one) at the transmitting station at the -13.02 dB (-1.5 Nep) point. At the output of the channels of this station, the induced noise voltage is measured at the 4.34 dB (+0.5 Nep) point with a noise meter. Each channel in turn becomes the driving interfering channel.

The voltage of the noise induced in the channel is determined from the formula:

$$U_{\text{ind. noise}} = \sqrt{U_{\text{meas.}}^2 - U_{\text{noise}}^2}, \text{ millivolts}$$

where  $U_{\text{meas.}}$  is the measured total noise voltage, consisting of the internal noise voltage of the channel and the voltage of the induced noise;  
 $U_{\text{noise}}$  is the inherent noise voltage of the channel.

The magnitude of the channel isolation in nepers against audible crosstalk conversation is determined from the formula:

$$A_i = \ln \frac{1,280}{U_{\text{ind. noise}}}, \text{ dB (Nep)}$$

where 1,280 (1,560 for KNK-6S, KNK-6SM and KNK-6T equipment) is the 800 Hz measurement frequency voltage at the 4.34 dB (+0.5 Nep) point (6.08 dB [+0.7 Nep] point for the KNK-6S, KNK-6M (6T) equipment), in millivolts.

The isolation against crosstalk conversation between the channels, both at the near and far ends of the same or different HF multiplex systems, operating on parallel circuits is measured on a four wire termination of the channels in both transmit directions for identically named channels.

The isolation against audible crosstalk conversation between the channels of one system, measured at 800 Hz, on one retransmission section both at the near and far ends, should be no less than 60.8 dB (7.0 Nep).

The isolation against crosstalk conversations between the channels of systems operating on parallel circuits for one retransmission section both at the near and far ends should be no less than 46.9 dB (5.4 Nep) for open wire steel lines and 50.4 dB (5.8 Nep) for cable lines.

For a retransmission section which differs from the norm, for example, on the low side, the amount of isolation should be determined from the formulas:

-- For steel open wire line circuits:

$$A_i = 5.4 + \frac{1}{2} \ln \frac{l_n}{l_d}$$

-- For cable lines:

$$A_i = 5.8 + \frac{1}{2} \ln \frac{l_n}{l_d}$$

where  $l_d$  is the actual length of the line over the retransmission section.

The amount of isolation between channels on one section in the presence of several repeaters is determined from the formulas:

-- For steel open wire lines:

$$A_i = 5.4 + \frac{1}{2} \ln n + \frac{1}{2} \ln \frac{l_n}{l_d}$$

-- For cable lines:

$$A_i = 5.8 + \frac{1}{2} \ln n + \frac{1}{2} \ln \frac{l_n}{l_d}$$

where  $n$  is the number of channel retransmissions.

---

8225  
CSO: 8344/4392

END