



**US Army Corps  
of Engineers**  
Engineer Research and  
Development Center

Technical Report REMR-CS-63  
September 1999

*Repair, Evaluation, Maintenance, and Rehabilitation Research Program*

## **Repair and Rehabilitation of Dams: Case Studies**

*by James E. McDonald, Nancy F. Curtis*

Approved For Public Release; Distribution Is Unlimited

20000203 034

**DTIC QUALITY INSPECTED 4**

Prepared for Headquarters, U.S. Army Corps of Engineers



The following two letters used as part of the number designating technical reports of research published under the Repair, Evaluation, Maintenance, and rehabilitation (REMR) Research Program identify the problem area under which the report was prepared:

| <u>Problem Area</u> |                               | <u>Problem Area</u> |                           |
|---------------------|-------------------------------|---------------------|---------------------------|
| CS                  | Concrete and Steel Structures | EM                  | Electrical and Mechanical |
| GT                  | Geotechnical                  | EI                  | Environmental Impacts     |
| HY                  | Hydraulics                    | OM                  | Operations Management     |
| CO                  | Coastal                       |                     |                           |

The contents of this report are not to be used for advertising, publication, or promotional purposes. Citation of trade names does not constitute an official endorsement or approval of the use of such commercial products.

The findings of this report are not to be construed as an official Department of the Army position, unless so designated by other authorized documents.



PRINTED ON RECYCLED PAPER

**Repair, Evaluation, Maintenance, and  
Rehabilitation Research Program**

Technical Report REMR-CS-63  
September 1999

# **Repair and Rehabilitation of Dams: Case Studies**

by James E. McDonald, Nancy F. Curtis

U.S. Army Engineer Research and Development Center  
Waterways Experiment Station  
3909 Halls Ferry Road  
Vicksburg, MS 39180-6199

Final report

Approved for public release; distribution is unlimited

**U.S. Army Engineer Research and Development Center Cataloging-in-Publication Data**

McDonald, James E.

Repair and rehabilitation of dams : case studies / by James E. McDonald, Nancy F. Curtis ; prepared for U.S. Army Corps of Engineers.

265 p. : ill. ; 28 cm. —(Technical report ; REMR-CS-63)

Includes bibliographic references.

1. Concrete dams — Maintenance and repair — Case studies. 2. Arch dams — Maintenance and repair — Case studies. 3. Buttress dams — Maintenance and repair — Case studies. 4. Gravity dams — Maintenance and repair — Case studies. I. Curtis, Nancy F. II. United States. Army. Corps of Engineers. III. U.S. Army Engineer Research and Development Center. IV. Repair, Evaluation, Maintenance and Rehabilitation Research Program. V. Title. VI. Series: Technical report REMR-CS ; 63.

TA7 E8 no.REMR-CS-63

# Contents

---

|  |     |
|--|-----|
| Preface .....                                | xiv |
| 1—Introduction .....                         | 1   |
| Background .....                             | 1   |
| Objective .....                              | 1   |
| Scope .....                                  | 1   |
| 2—Case Histories .....                       | 3   |
| New Orleans District .....                   | 3   |
| Old River Low-Sill Control Structure .....   | 3   |
| St. Louis District .....                     | 11  |
| Lock and Dam No. 24, Mississippi River ..... | 11  |
| Wappapello Dam .....                         | 17  |
| Omaha District .....                         | 18  |
| Oahe Dam .....                               | 18  |
| Baltimore District .....                     | 20  |
| Indian Rock Dam .....                        | 20  |
| Little Falls Dam .....                       | 21  |
| New York District .....                      | 24  |
| Troy Lock and Dam .....                      | 24  |
| Detroit District .....                       | 26  |
| Menasha Dam .....                            | 26  |
| Rock Island District .....                   | 26  |
| Brandon Road Dam .....                       | 26  |
| Dresden Island Lock and Dam .....            | 31  |
| LaGrange Lock and Dam .....                  | 35  |
| Lock and Dam No. 20, Mississippi River ..... | 36  |
| Marseilles Dam .....                         | 41  |
| Peoria Lock and Dam .....                    | 45  |
| Red Rock Dam .....                           | 48  |
| Starved Rock Lock and Dam .....              | 51  |
| St. Paul District .....                      | 54  |
| Lock and Dam No. 1, Mississippi River .....  | 54  |
| Lock and Dam No. 2, Mississippi River .....  | 55  |
| Lock and Dam No. 6, Mississippi River .....  | 56  |
| Seattle District .....                       | 57  |

|                                     |     |
|-------------------------------------|-----|
| Chief Joseph Dam .....              | 57  |
| New Exchequer Dam .....             | 63  |
| Walla Walla District .....          | 67  |
| Dworshak Dam .....                  | 67  |
| Lucky Peak Dam .....                | 69  |
| Huntington District .....           | 74  |
| Alum Creek Dam .....                | 74  |
| Delaware Dam .....                  | 77  |
| Mohawk Dam .....                    | 78  |
| R. D. Bailey Dam .....              | 83  |
| Sutton Dam .....                    | 86  |
| Tom Jenkins Dam .....               | 88  |
| Nashville District .....            | 91  |
| Center Hill Dam .....               | 91  |
| Pittsburgh District .....           | 93  |
| Loyalhanna Dam .....                | 93  |
| Point Marion Lock and Dam .....     | 96  |
| Stonewall Jackson Dam .....         | 100 |
| Tygart Dam .....                    | 106 |
| Mobile District .....               | 106 |
| Columbus Lock and Dam .....         | 106 |
| Wilmington District .....           | 108 |
| Philpott Lake Dam .....             | 108 |
| Albuquerque District .....          | 110 |
| Abiquiu Dam .....                   | 110 |
| Little Rock District .....          | 114 |
| Clearwater Lake Dam .....           | 114 |
| DeQueen Dam .....                   | 115 |
| Gillham Dam .....                   | 118 |
| Norfolk Dam .....                   | 119 |
| Wilbur D. Mills Dam .....           | 121 |
| Bureau of Reclamation (BuRec) ..... | 125 |
| A. R. Bowman Dam .....              | 125 |
| Cottonwood Dam No. 5 .....          | 126 |
| Friant Dam .....                    | 127 |
| Gibson Dam .....                    | 129 |
| Glen Canyon Dam .....               | 130 |
| Grand Coulee Dam .....              | 135 |
| Stewart Mountain Dam .....          | 137 |
| Theodore Roosevelt Dam .....        | 140 |
| Upper Stillwater Dam .....          | 147 |
| UTE Dam .....                       | 151 |
| Tennessee Valley Authority .....    | 152 |
| Chickamauga Lock and Dam .....      | 152 |
| Fontana Dam .....                   | 154 |
| Other Structures .....              | 157 |
| Bhakra Dam .....                    | 157 |
| Big Eddy Dam .....                  | 159 |
| Lake Buchanan Dam .....             | 162 |
| Burrinjuck Dam .....                | 165 |

|                                    |     |
|------------------------------------|-----|
| Crescent Dams .....                | 166 |
| Vischer Ferry Dams .....           | 169 |
| Daniel Johnson Dam .....           | 171 |
| Delta Dam .....                    | 171 |
| Easton Dam .....                   | 174 |
| Fuelbecke Dam .....                | 176 |
| Glines Canyon Dam .....            | 177 |
| Haweswater Dam .....               | 179 |
| Hoist Dam .....                    | 180 |
| Humphreys Dam .....                | 184 |
| International Control Dam .....    | 186 |
| Kamburu Dam .....                  | 188 |
| Lost Creek Dam .....               | 193 |
| Mactaquac Dam .....                | 197 |
| Morris Sheppard Dam .....          | 200 |
| Olmos Dam .....                    | 206 |
| Santeetlah Dam .....               | 209 |
| Shepaug Dam .....                  | 211 |
| Sherman Island Dam .....           | 212 |
| Snake River Dams .....             | 216 |
| Soda Dam .....                     | 219 |
| Stillwater Dam .....               | 222 |
| Versuvius Dam Spillway .....       | 224 |
| Waste House Dams No. 1 and 3 ..... | 226 |
| Williams Bridge Dam .....          | 228 |
| Wissota Dam .....                  | 230 |
| <br>                               |     |
| 3—Conclusion .....                 | 236 |
| <br>                               |     |
| References .....                   | 237 |

SF 298

## List of Figures

---

|   |   |
|---|---|
| Figure 1. Old River Control Project, Mississippi River .....  | 4 |
| Figure 2. Sand closure for dewatering stilling basin at Old River<br>Control Project, Mississippi River .....               | 5 |
| Figure 3. Failed tread rail in Downstream Gate Bay 7, Old River<br>Control Structure, Mississippi River .....               | 6 |
| Figure 4. Failed guide rail in north side of Gate Bay 5 in Old River<br>Low-Sill Control Structure, Mississippi River ..... | 7 |
| Figure 5. Rail repair closure in Old River Low-Sill Structure,<br>Mississippi River .....                                   | 9 |

|            |  |    |
|------------|--|----|
| Figure 6.  | Completed rail system repairs, Old River Low-Sill Structure, Mississippi River . . . . .   | 10 |
| Figure 7.  | Baffle Block repaired with shotcrete to restore original configuration and halt further erosion, Old River Control Structure . . . . . | 11 |
| Figure 8.  | Cracking and deterioration of concrete, Mississippi River Lock and Dam No. 24 . . . . .  | 16 |
| Figure 9.  | Cross section of Little Falls, Dam, showing typical flow conditions below the dam . . . . .  | 21 |
| Figure 10. | Plan for placement of grout-filled bags to eliminate the roller at Little Falls Dam . . . . .  | 22 |
| Figure 11. | Work barge with raised deflection gate, Little Falls Dam . . . . .   | 23 |
| Figure 12. | Spacing frame used for placing grout-filled bags at Little Falls Dam . . . . .   | 24 |
| Figure 13. | Inflated grout bags installed; spacing frame removed . . . . .   | 25 |
| Figure 14. | Head gate section of Brandon Road Dam after rehabilitation . . . . .   | 28 |
| Figure 15. | Head gate section on upstream face at Brandon Road Dam after rehabilitation . . . . .  | 29 |
| Figure 16. | Repairs to the horizontal deck of the head gate section at Brandon Road Dam . . . . .  | 29 |
| Figure 17. | Boiler house after rehabilitation, Brandon Road Dam . . . . .  | 30 |
| Figure 18. | Reinforcing and forms for head gate closure panels at Dresden Island Lock and Dam . . . . .  | 32 |
| Figure 19. | Downstream face of head gate section after rehabilitation, Dresden Island Lock and Dam . . . . .                                       | 32 |
| Figure 20. | Concrete removal and anchors for the arch dam at Dresden Island Lock and Dam . . . . .   | 33 |
| Figure 21. | The south abutment of the arch dam after rehabilitation, Dresden Island Lock and Dam . . . . .   | 34 |
| Figure 22. | Concrete placed in the ice chute during conversion to ogee crest, Dresden Island Lock and Dam . . . . .                                | 34 |
| Figure 23. | Completed ice chute, Dresden Island Lock and Dam . . . . .   | 35 |



|            |  |    |
|------------|--|----|
| Figure 24. | Braced steel sheet-pile cofferdam, LaGrange Lock and Dam . . . .   | 37 |
| Figure 25. | Concrete placement in riverward pier at LaGrange Lock<br>and Dam . . . . .   | 37 |
| Figure 26. | Placing of submersible gate, LaGrange Lock and Dam . . . . .   | 38 |
| Figure 27. | Epoxy injection of pier stem at Lock and Dam No. 20,<br>Mississippi River . . . . .  | 39 |
| Figure 28. | Local cofferdam used to dewater bullnose piers,<br>Marseilles Dam . . . . .  | 42 |
| Figure 29. | Concrete removal of ogee crest and side of pier to accommodate<br>new gate, Marseilles Dam . . . . .   | 43 |
| Figure 30. | Line drilling for concrete removal at Marseilles Dam . . . . .   | 44 |
| Figure 31. | Twenty-nine thousand thirty and four-tenths-kilogram (32-ton)<br>section cut from pier with diamond wire cutter,<br>Marseilles Dam . . . . . | 45 |
| Figure 32. | Concrete placement in new gate sill, Marseilles Dam . . . . .  | 46 |
| Figure 33. | Peoria Dam before a section of the wicket dam was replaced<br>with a submersible gate . . . . .  | 47 |
| Figure 34. | Completed piers and gate constructed at Peoria Dam . . . . .   | 48 |
| Figure 35. | Anchor and concrete placement at the end sill, Red Rock Dam . .  | 49 |
| Figure 36. | Concrete pump used for end sill repair at Red Rock Dam . . . . .   | 50 |
| Figure 37. | Anchors and waterstop installed in head gate section, Starved<br>Rock Lock and Dam . . . . .   | 52 |
| Figure 38. | Forms and openings for pumping concrete for closure panels<br>in head gate section, Starved Rock Lock and Dam . . . . .                      | 52 |
| Figure 39. | Tainter gate pier after rehabilitation, Starved Rock Dam . . . . .   | 53 |
| Figure 40. | Ice chute after being converted to ogee crest, Starved Rock<br>Dam . . . . .   | 54 |
| Figure 41. | Chief Joseph dam with completed 27-unit powerhouse and<br>raised dam . . . . .   | 57 |

|            |  |    |
|------------|--|----|
| Figure 42. | False pier with boxes that make spillway face and pier even,<br>Chief Joseph Dam .....   | 58 |
| Figure 43. | Floating cofferdam positioned for dewatering for pier<br>modifications at Chief Joseph Dam .....   | 59 |
| Figure 44. | Piers raised and widened to resist greater head at Chief<br>Joseph Dam .....   | 59 |
| Figure 45. | Monolith section showing leakage, Chief Joseph Dam .....   | 60 |
| Figure 46. | Frame-mounted remote-controlled camera and pneumatic<br>equipment used for inspection and repair of monoliths at<br>Chief Joseph Dam ..... | 62 |
| Figure 47. | Details of repair for open, leaking joints at<br>New Exchequer Dam .....   | 65 |
| Figure 48. | Details of joint covers used at New Exchequer Dam .....  | 65 |
| Figure 49. | Details of installation of geomembrane over toe fill at<br>New Exchequer Dam .....   | 66 |
| Figure 50. | Upstream (left) and downstream views of cavitation<br>in flip-bucket floor in channel no. 1, Lucky Peak Dam .....                          | 71 |
| Figure 51. | Spray from outlet no. 5 reaches Highway 21, Lucky Peak<br>Dam .....  | 71 |
| Figure 52. | Outlet channel of flip bucket no. 4 with steel plates on the<br>walls, Lucky Peak Dam .....  | 72 |
| Figure 53. | Plan for repairing outlet works, Lucky Peak Dam .....  | 73 |
| Figure 54. | Anchoring spillway monoliths at Alum Creek Dam .....   | 75 |
| Figure 55. | Anchor strands, cut and bound, for Alum Creek Dam .....  | 76 |
| Figure 56. | Construction of a parapet wall on the upstream crest of<br>Mohawk Dam .....  | 80 |
| Figure 57. | Forming for construction of additional monolith on the<br>right side of the spillway, Mohawk Dam .....                                     | 81 |
| Figure 58. | Holes drilled for installation of posttensioning anchors on<br>spillway crest, Mohawk Dam .....  | 81 |
| Figure 59. | Forming and reinforcing for the top lift of concrete for the<br>apron, Mohawk Dam .....  | 82 |

|            |  |     |
|------------|--|-----|
| Figure 60. | Placing and finishing concrete for the top of the spillway apron, Mohawk Dam .....             | 82  |
| Figure 61. | Upstream face and baffles in dewatered stilling basin, R. B. Bailey Dam .....                  | 84  |
| Figure 62. | Intake structure and access bridge, R. D. Bailey Dam .....                                     | 85  |
| Figure 63. | Aerial view of Sutton Dam .....  | 87  |
| Figure 64. | General design details of high-level intake at Sutton Dam .....                                | 88  |
| Figure 65. | Connection detail for intake at Sutton Dam .....   | 89  |
| Figure 66. | Stilling basin dewatered for fifth periodic inspection, Tom Jenkins Dam .....                  | 90  |
| Figure 67. | Spalled area in monolith joint on right basin wall, Tom Jenkins Dam .....                      | 90  |
| Figure 68. | Upstream view of Center Hill Dam .....   | 91  |
| Figure 69. | Fixed bridge support leaning toward the center of the spillway at Center Hill Dam .....        | 93  |
| Figure 70. | Sawcutting and coring to shorten concrete bridge deck at Center Hill Dam .....                 | 94  |
| Figure 71. | Minor cracking below and to the right of selected repair on parapet wall, Loyalhamma Dam ..... | 95  |
| Figure 72. | Downstream face of Point Marion Dam; end of old land wall is at right .....                    | 99  |
| Figure 73. | Right-side fixed weir section, Point Marion Lock and Dam .....                                 | 99  |
| Figure 74. | Gate arm and guide slot of tainter gate, Point Marion Lock and Dam .....                       | 100 |
| Figure 75. | Bug holes on the upstream face of Stonewall Jackson Dam .....                                  | 103 |
| Figure 76. | Access stairway for tower no. 1 separated from dam face at Stonewall Jackson Dam .....         | 103 |
| Figure 77. | Spalling beneath access stairway at water quality tower no. 2, Stonewall Jackson Dam .....     | 104 |
| Figure 78. | Leakage at monolith joint 5/6, Stonewall Jackson Dam .....                                     | 105 |

|            |   |     |
|------------|---|-----|
| Figure 79. | Stainless steel brackets installed to support water quality tower stairway .....                  | 105 |
| Figure 80. | Plan for outlet works modification at Abiquiu Dam .....   | 111 |
| Figure 81. | Plenum chamber at Abiquiu Dam .....   | 112 |
| Figure 82. | Flexifloat barge assembly, Abiquiu Dam .....  | 113 |
| Figure 83. | Removal of south bulkhead gate, Abiquiu Dam .....   | 114 |
| Figure 84. | Condition of stilling basin at DeQueen Dam in 1993 .....  | 117 |
| Figure 85. | Erosion Damage in stilling basin, Gillham Lake Dam .....  | 120 |
| Figure 86. | Steel rods used to reinforce cantilever portion of Norfolk Dam .....                              | 122 |
| Figure 87. | Repair stilling basin at Wilbur D. Mills Dam .....  | 123 |
| Figure 88. | Lay barge with hopper barge positioned for sinking at Wilbur D.Mills Dam .....                    | 123 |
| Figure 89. | Lay barge with a flooded hopper barge being lowered to the river bed at Wilbur D. Mills Dam ..... | 124 |
| Figure 90. | Alkali-aggregate extrusion on the downstream face of Friant Dam .....                             | 128 |
| Figure 91. | Fabrication of Obermeyer Pneumatic Spillway Gates for installation at Friant Dam .....            | 128 |
| Figure 92. | Gibson Dam following rehabilitation and construction of splitter piers .....                      | 129 |
| Figure 93. | Cavitation damage downstream of the elbow in the left spillway tunnel at Glen Canyon Dam .....    | 131 |
| Figure 94. | Steel reinforcing steel being replaced in the invert of the spillway elbow at Glen Canyon .....   | 133 |
| Figure 95. | Aeration slot, Glen Canyon Dam .....  | 134 |
| Figure 96. | Overview of Stewart Mountain Dam .....  | 138 |
| Figure 97. | Profile Stewart Mountain Dam, showing locations of posttensioned tendons .....                    | 139 |
| Figure 98. | Arched tendons used to stabilize Stewart Mountain Dam .....                                       | 139 |

|   |     |
|---|-----|
| Figure 99. Theodore Roosevelt Dam prior to rehabilitation . . . . .   | 141 |
| Figure 100. Alternating cantilevered placement of mass concrete<br>blocks at Theodore Roosevelt Dam . . . . . | 142 |
| Figure 101. Bench excavation for Theodore Roosevelt Dam lake tap . . . . .                                    | 144 |
| Figure 102. Inlet tube shaft at Theodore Roosevelt Dam . . . . .  | 145 |
| Figure 103. Inlet tube placement with tremie concrete at Theodore<br>Roosevelt Dam . . . . .                  | 145 |
| Figure 104. Penstock tunnel installed at Theodore Roosevelt Dam . . . . .                                     | 146 |
| Figure 105. Modifications performed at Theodore Roosevelt Dam . . . . .                                       | 147 |
| Figure 106. Leakage into the foundation gallery at Upper Stillwater Dam . .                                   | 148 |
| Figure 107. Plan for first injection stage at Upper Stillwater Dam . . . . .                                  | 149 |
| Figure 108. Injection plan for Stage 2 of Upper Stillwater Dam repair . . . . .                               | 149 |
| Figure 109. Work platform used at Upper Stillwater Dam . . . . .  | 150 |
| Figure 110. Ute Dam with completed labyrinth spillway . . . . .   | 153 |
| Figure 111. Crack repair with posttensioning tendons at Fontana Dam . . . . .                                 | 156 |
| Figure 112. Design of pneumatic caisson and the sinking set used at<br>Bhakra Dam . . . . .                   | 158 |
| Figure 113. Big Eddy Dam . . . . .  | 159 |
| Figure 114. Deteriorated shotcrete repair on the downstream face of<br>Big Eddy Dam . . . . .                 | 160 |
| Figure 115. Downstream view of Lake Buchanan Dam . . . . .  | 163 |
| Figure 116. Joint leakage at Buchanan Dam . . . . .   | 164 |
| Figure 117. Injection of foam to stop joint leaks at Buchanan Dam . . . . .                                   | 165 |
| Figure 118. Section through Burrinjuck Dam, showing details of raising<br>height of dam 40 ft . . . . .       | 166 |
| Figure 119. Crescent Dams . . . . .   | 167 |
| Figure 120. Portable cofferdam used upstream at Crescent Dams . . . . .                                       | 168 |
| Figure 121. Typical spillway repair in progress at Crescent Dams . . . . .                                    | 169 |

|  |     |
|--|-----|
| Figure 122. Vischer Ferry Dams .....   | 170 |
| Figure 123. Details for installation of posttensioning anchors at<br>Delta Dam .....   | 173 |
| Figure 124. Permeability control with Zemdrain liner used at Fuelbecke<br>Dam .....  | 176 |
| Figure 125. Test specimens showing concrete placed with conventional<br>formwork and formwork lined with Zemdrain .....                          | 177 |
| Figure 126. Power-operated cradles used for making repairs to<br>downstream face of Haweswater Dam .....   | 180 |
| Figure 127. Deterioration on downstream face of Hoist Dam .....  | 181 |
| Figure 128. Repair work underway on downstream face of Hoist Dam .....   | 182 |
| Figure 129. Patchwork repairs on upstream face of Hoist Dam .....  | 183 |
| Figure 130. Upstream elevation and typical section of Kamburu Dam<br>Spillway .....  | 189 |
| Figure 131. Modifications to radial gate, embedded pars and skin plate, at<br>Kamburu Dam Spillway .....   | 191 |
| Figure 132. Grout locations on Pier 1 of the spillway at Kamburu Dam .....   | 192 |
| Figure 133. Cross section showing the Corps' conceptual design for a<br>typical geomembrane system installation .....                            | 194 |
| Figure 134. Geonet installed on dam face with plastic impact anchors prior<br>to installation of geomembrane at Lost Creek Dam .....             | 195 |
| Figure 135. Workers anchor internal vertical profiles over geonet at<br>Lost Creek Dam in preparation for installation of a<br>geomembrane ..... | 195 |
| Figure 136. Workers on swing stages install 16 precut geomembrane<br>panels on the upstream face of Lost Creek Dam .....                         | 196 |
| Figure 137. Mactaquac Dam .....  | 197 |
| Figure 138. Diamond wire cutting of Mactaquac Dam .....  | 199 |
| Figure 139. Downstream view, Morris Sheppard Dam .....   | 201 |
| Figure 140. Muck being removed from bay at Morris Sheppard .....   | 203 |

|  |     |
|--|-----|
| Figure 141. Placement of prestressed reinforcing to strengthen nonoverflow sections at Olmos Dam .....                                   | 207 |
| Figure 142. Spillway section strengthened with mass concrete at Olmos Dam .....  | 208 |
| Figure 143. Layout of Shanteetlah Dam .....  | 209 |
| Figure 144. Investigation and treatment plan for horizontal joints in Blocks 23 and 24 at Santeetlah Dam .....                           | 210 |
| Figure 145. Overview of Sherman Island Dam rehabilitation project. The arch section of the dam was removed by diamond wire cutting ..... | 213 |
| Figure 146. Typical configuration of a diamond wire-cutting machine and wire .....   | 214 |
| Figure 147. View of two arches prepared for removal at Sherman Island ...  | 214 |
| Figure 148. Order of removal of typical transverse section of Sherman Island Dam .....   | 215 |
| Figure 149. Individual floating caisson used to construct floating bulkhead at Snake River Dams .....                                    | 217 |
| Figure 150. Floating caissons joined to form floating bulkhead at Snake River Dams .....   | 218 |
| Figure 151. Nonoverflow gravity dam section at Soda Dam .....  | 220 |
| Figure 152. Seepage on downstream face of gravity section of Soda Dam ..   | 221 |
| Figure 153. Chemical grouting of upstream face of Soda Dam .....   | 222 |
| Figure 154. General plan for Vesuvius Dam and spillway .....   | 225 |
| Figure 155. Plan for submerged intake structure at Waste House Dam No. 1 .....   | 228 |
| Figure 156. Plan for replacement of South dam at Wissota Hydroelectric Project .....   | 232 |
| Figure 157. Cross section of design of floating bulkhead, Wissota Hydro Project .....  | 234 |
| Figure 158. Caissons fill on floating bulkhead, causing bulkhead to sink, Wissota Hydro Project .....                                    | 235 |
| Figure 159. Floating bulkhead used to repair head gates, stop logs, and trash racks at Wissota Hydro Project .....                       | 235 |

# Preface

---

The study reported herein was authorized by Headquarters, U.S. Army Corps of Engineers (HQUSACE), under Civil Works Research Work Unit 32639, "Repair and Rehabilitation of Dams," for which Mr. James E. McDonald, Structures Laboratory (SL), Waterways Experiment Station (WES), Vicksburg, MS, U.S. Army Engineer Research and Development Center (ERDC), was the Principal Investigator. This work unit was part of the Concrete and Steel Structures Problem Area of the Repair, Evaluation, Maintenance, and Rehabilitation (REMR) Research Program.

The REMR Technical Monitor was Mr. M. K. Lee, HQUSACE. Dr. Tony C. Liu (CERD-C) was the REMR Coordinator at the Directorate of Research and Development, HQUSACE. Mr. Harold C. Tohlen (CECW-O) and Dr. Liu served as the REMR Overview Committee. Mr. McDonald was the Problem Area Leader for Concrete and Steel Structures. This report was prepared by Mr. McDonald, Concrete and Materials Division (CMD), SL, and Ms. Nancy F. Curtis, Contractor, under the general supervision of Dr. Paul F. Mlakar, Chief, CMD, and Dr. Bryant Mather, Director, SL, WES.

Copyright permission to reprint material in this document was requested and granted, and courtesy credit lines are indicative of this material.

At the time of publication of this report, Dr. Lewis E. Link was Acting Director of ERDC, and COL Robin R. Cababa, EN, was Commander.

*The contents of this report are not to be used for advertising, publication, or promotional purposes. Citation of trade names does not constitute an official endorsement or approval of the use of such commercial products.*



# 1 Introduction

---

## Background

A Repair, Evaluation, Maintenance, and Rehabilitation (REMR) Research study conducted by McDonald and Campbell (1985), U.S. Army Engineer Research and Development Center, Waterways Experiment Station (WES), to determine the condition of concrete in the U.S. Army Corps of Engineers (USACE) civil works structures revealed that more than 60 percent of the deficiencies described in periodic inspection reports were located in dams. Concrete cracking was the deficiency most often reported. Other major problem areas were seepage and spalling. Since many of the concrete dams in the United States today are operating beyond their normal 50-year service life and will have to continue to be operable, there is a great need for information concerning the repair and rehabilitation of these structures. This report provides current information on repair and rehabilitation performed at selected dams. Materials and methods used at these projects include familiar and conventional approaches, as well as new, innovative applications. Some of the repairs are simple and routine; others are highly complex and require trained personnel to perform. Some methods and materials can be used as described; others will serve as an impetus to the development of even more durable, cost-effective methods for preserving this vital part of the nation's infrastructure.

## Objective

The objective of this study was to identify current practices in the repair and rehabilitation of concrete dams through a review and analysis of selected case histories.

## Scope

Input on methods for repairing and rehabilitating hydraulic structures was obtained through (a) literary searches, (b) discussions with designers and contractors, (c) visits to project sites, and (d) discussions with project personnel.

The information was checked for completeness, and, in some cases, follow-up contact was made to obtain missing data or to clarify information.

For each case study included in this report, an attempt was made to obtain (a) a description of the project, (b) the cause and extent of the deficiency that required repair or replacement, (c) design details, (d) mixture proportions, (e) descriptions of materials, equipment, and placement procedures, (f) costs, and (g) an evaluation of the repair to date.

## 2 Case Histories

---

### New Orleans District

#### Old River Low-Sill Control Structure

The Old River Control Project is located on the Mississippi River about 80 km (50 miles) northwest of Baton Rouge, LA, and about 56 km (35 miles) southwest of Natchez, MS. The project was developed in the late 1950s to prevent the Mississippi River from merging with the Atchafalaya River as it made its way to the Gulf of Mexico. This union would have negated millions of dollars of flood protection in place in the Lower Mississippi Valley and would have created major problems for the industrial area south of Baton Rouge (Hassenboehler 1988).

The Old River Control Project consists of a reinforced concrete, low-sill control structure, an inflow channel from the Mississippi River and an outflow channel to the Red River, the over-bank structure, a navigation lock, an earthen dam to close off the old channel, and a levee (Figure 1). The 200-m- (655-ft-) long low-sill structure consists of 11 gated-monoliths, inflow training walls, a concrete approach apron, and a stilling basin. The training walls, approach apron, and stilling basin have a soil foundation (Hassenboehler 1988). The monoliths are supported on steel piles. Each of the 11 gate bays has a 13.4-m (44-ft) clear width between piers. The three center bays--designated as low bays--have a weir crest elevation (el) of -5.<sup>1</sup> The eight outer bays--the high bays--crest at el +10. Steel vertical lift gates, controlled by two traveling gantry cranes, are used to regulate flow through the structure. An 8-m- (26-ft-) wide highway bridge on the downstream side of the low sill is part of Louisiana State Highway No. 15 (U.S. Army Engineer District (USAED), New Orleans 1988).

Completed in 1959, the Old River Control Project became operable in 1963. It performed as expected with only minor scour problems until the flood of 1973, which left a 16.8-m (55-ft-) deep scour hole in the inflow channel that threatened total failure of the structure. Emergency repairs consisted of filling the hole with

---

<sup>1</sup> All elevations (el) cited herein are in feet referred to National Geodetic Vertical Datum (NGVD) of 1929.

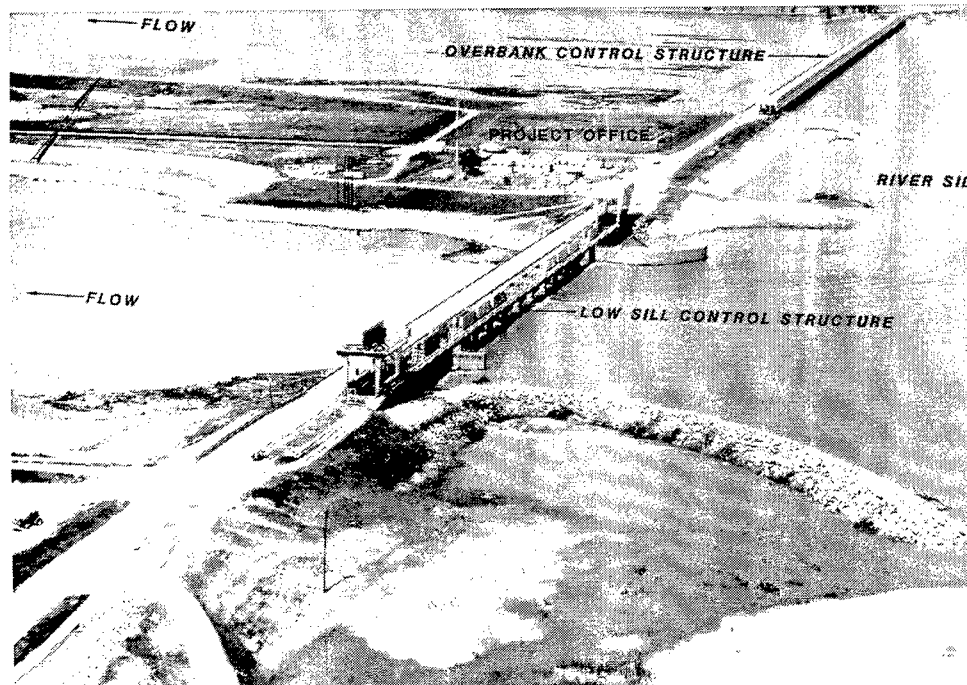

Figure 1. Old River Control Project, Mississippi River (from U.S. Army Engineer District, New Orleans 1988)

riprap and grouting undermined areas of the structure with a special cement grout mixture (Hassenboehler 1988). Once the emergency was under control, a major rehabilitation program was undertaken. As a part of this program, annual underwater inspections of the structure, channels, and stilling basin were initiated. These inspections indicated the stilling basin floor was continuing to erode (Hassenboehler 1988).

As a result of an inspection of the stilling basin in August 1976, engineers determined that damage to the stilling basin slab in the area between the end-sill wall and downstream row of baffle blocks was extensive enough that repair was imperative but that the structure would not be closed to facilitate repair. After an exhaustive investigation and study of repair plans, engineers selected the plan that would provide the greatest durability and economy and that would require a minimum time for construction: steel plate modules were anchored and grouted to the end sill and to the floor slab in the damaged area. This work was performed underwater (McDonald 1980). While the repair work was being done, a stability analysis of the low-sill structure was being performed. The analysis showed that the maximum differential head of 11.3 m (37 ft) had been reduced to 6.7 m (22 ft); under this restriction, the structure could meet day-to-day requirements but not emergencies. The only solution for meeting emergency requirements was to build an auxiliary structure (Hassenboehler 1988). Authorization for the structure was obtained in October 1979; work began October 1981 and the structure was completed in September 1987 (USAED, New Orleans 1988).

**Dewatering.** The auxiliary structure allowed the low-sill structure to be completely closed so the stilling basin could be dewatered for inspection and repairs. A dewatering analysis was conducted to evaluate the stability of the pile-foundation gated monoliths and stilling basin flotation and to determine what type of downstream channel closure to use. The gated monoliths were chosen as the upstream closure, making it possible to dewater the stilling basin when the Mississippi River reached el 30 or below. This elevation and the minimum anticipated differential head across the structure were used to calculate the downstream closure height.

After studying various closure options, engineers decided to use a sand closure, because it could be easily constructed in a minimum amount of time. However, because there were risks involved in working with sand, the engineers included collection pipes, a rock dike, filter fabric to hold the sand, and a dewatering system upstream of the sand closure crown in the plan (Figure 2) (Hassenboehler 1988).



Figure 2. Sand closure for dewatering stilling basin at Old River Control Project, Mississippi River (from Hassenboehler)

While plans and specifications for constructing the sand closure were being developed and 6 days before the annual underwater stilling basin inspection was to begin, the lower (5.2 m (17 ft)) of the support rails at Gate Bay 7 failed (Figure 3). To prevent delay of the inspection, workers bolted wide-flange beams to the two lower gate panels so the bottom panel could swing past the absent section of the rail into its closed position. Permanent repair plans were postponed until the dewatering. Just 4 days before the low-sill structure was to be dewatered, an upstream guide rail in Gate Bay 5 failed (Figure 4). As a result of these two failures, the high bay support rail systems were inspected. The inspection showed that all of the systems were corroded and in need of repair (USAED, New Orleans 1988).



Figure 3. Failed tread rail in Downstream Gate Bay 7, Old River Control Structure, Mississippi River (from U.S. Army Engineer District, New Orleans 1988)

**Rail system repair.** In order to repair the damaged rail system, workers had to remove the gate; therefore, a repair closure had to be constructed. Original construction provisions for installing a closure system had to be modified, as they were based on a 6.4-m (21-ft) head, and stability analysis of the pile foundation indicated there could be a 10.7-m (35-ft) head across this structure. The needles (vertical panels) had to be much taller. PZ-22 steel sheetpiling was chosen over prestressed concrete for making the needles, because sheetpiling would require less time to construct the needles, it would cost less, and it would be easier to install. Next, the needle beam was modified from a wide-flange beam to a welded high-strength plate girder with tapered ends that would fit into the pier slots. The increased height of the needles and the location of the needle beam made it necessary to install an upper safety strut to increase stability against waves and impact loads (Hassenboehler 1988).



Figure 4. Failed guide rail in north side of Gate Bay 5 in Old River Low-Sill Control Structure, Mississippi River (from U.S. Army Engineer District, New Orleans 1988)

An underwater inspection revealed that the needle seat was eroded and could not support the needles. A “Z”-shaped needle support plate and anchor bolt system were designed to provide full support for the needles, regardless of any support offered by the existing seat lip. The anchor bolts were capable of resisting pure shearing or a combination of shearing and bending.

The first step in installing the rail repair closures was to anchor the needle support in the needle seat of the gatebay slab. A drilling template was attached to the needle support before it was lowered into position. Drillers, working from a platform suspended above the water, lowered the drill casing into the water, where divers guided it into a vertical riser pipe on the drilling template. Since the work was being performed in 10.7 m (35 ft) of water, the vertical riser pipe helped the divers maintain the specified alignment. The divers would then leave the water while workers drilled a core through the concrete to a depth of approximately 457 mm (18 in.). The divers would then guide the drill casing to

the next location. This procedure was used to drill the 123 holes needed for the gate bay (USAED, New Orleans 1988).

**Anchor installation.** When drilling was completed, divers installed the Hilti HVA 31.75-mm- (1-1/4-in.-) diam, 482-mm- (19-in.-) long adhesive anchors. An air hose was used to clean debris from the holes, and then two different Hilti chemical cartridges were inserted to a depth of 381 mm (15 in.), and the anchor bolts were spun into the holes. The chemicals were given time to react with each other to form a vinyl resin epoxy, and then the nuts were torqued to manufacturer's specifications (McDonald 1989). Because the epoxy in some of the holes took longer than was specified to reach its strength, each bolt was torque tested. The failure rate was between 2 and 3 percent. All failures were removed and reinstalled with the same procedure. When the anchor bolts were set, nonshrink grout was pumped between the concrete seat and the anchor plate (USAED, New Orleans 1988).

Six needle support brackets were installed to keep the needle beam from rotating. The 11,350-kg (25,000-lb) needle beam was inserted into the pier slots, and the supports were placed between the needle beam and the concrete and bolted to the beam. The upper safety strutt provided a platform for workers who directed the needles into position; divers guided the needles underwater and bolted them to the needle beam. Technicians then pumped water from the area between the needles and the gate down to the same level as that in the tail bay. After caulking around the needles, they removed the gate. The last step was to install the 3.4-m- (11-ft-) diam, 7.6-m- (25-ft-) tall, 11,804-kg (26,000-lb) half-round cofferdams (Figure 5) (USAED, New Orleans 1988).

**Tread rail inspection.** With the cofferdams in place, workers could inspect the tread rails on the low bays, even though the stilling basin had not been dewatered. A decision was made to install new guide rails. All hardware and rails below el +35.0 were removed and replaced, except the embedded beam and the old splice plate. They were both sandblasted, and the old splice plate was repainted (USAED, New Orleans 1988). As further protection against the damaging effects of erosion and corrosion, all downstream hardware was welded together and completely encased in concrete. Since this procedure could not be used with the upstream hardware, the amount of hardware used in this area was doubled. (Hassenboehler 1988). Following adjustment and alignment of the new rails, the rails, hardware, and embedded beam were painted with a vinyl paint system from el +35.0 to el -5.0 (USAED, New Orleans 1988).

While the stilling basin was being dewatered, engineers inspected the tread rails and hardware in the high bay gates. The same type of erosion was found here as in the low bay gates; however, the damage was less extensive. Since the contractor had completed repairs to the low gate bays in half the contract time, the USACE decided to have him repair as many of the high gate bays as possible in the remaining contract time. All of the repair work was completed by the end of the contract period (Figure 6) (USAED, New Orleans 1988).



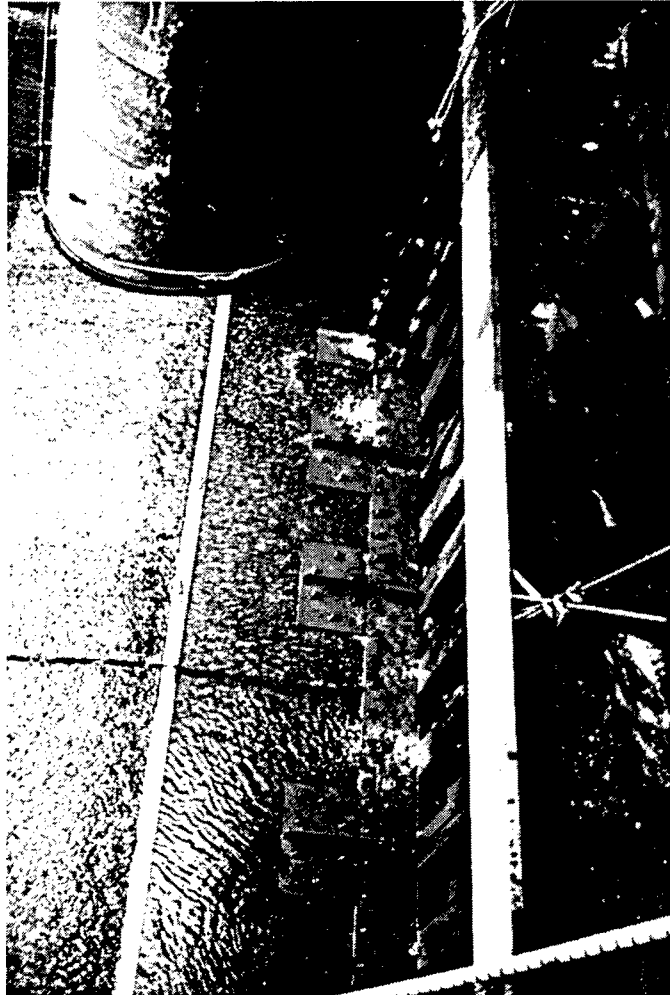

Figure 5. Rail repair closure in Old River Low-Sill Structure, Mississippi River (from U.S. Army Engineer District, New Orleans 1988)

With the sand closure in place, dewatering the stilling basin was set to begin. A major concern was the buildup of uplift pressures beneath the stilling basin as the water was removed. Eighteen additional piezometers were installed throughout the stilling basin so areas of excessive pressure could be identified. A relief well was installed in the south high bays and in the low bays. Pumps were placed in manholes that led to the collector pipes in the drainage system. Water was pumped primarily from the relief well in the low bays and the downstream collector pipe (Hassenboehler 1988).

Once the water and the silt deposited on the stilling basin slab were removed, visual inspections were performed. Most of the findings were similar to those reported in the eight previous underwater inspections. There were areas of erosion and undercutting; however, all of the plate modules installed in 1976 were intact, and the exposed grout had only minor irregularities. A number of baffle blocks had exposed reinforcement, typically near the bottom of the block. The bases of transition walls between the low and high bays were deteriorated,



Figure 6. Completed rail system repairs, Old River Low-Sill Structure, Mississippi River (from U.S. Army Engineer District, New Orleans 1988)

but previously placed underwater patches were still intact. No significant damage was observed on the stilling basin walls (USAED, New Orleans 1988).

**Stilling basin repair.** After the inspection, workers began preparing the stilling basin slab for a 305-mm (12-in.) overlay of 34.5 MPa (5,000-psi) concrete with a low water-cement ratio (w/c). Over 10,000 hooked dowels were epoxied into the existing slab to anchor the overlay; then forms were erected, reinforcing steel was installed, piezometers installed in the slab were capped (two were left as permanent working piezometers), and over 1,529 cu m (2,000 cu yd) of concrete was placed. The overlay covered most of the damage to the baffle blocks. Damaged areas that extended above the overlay were repaired with shotcrete, a polymer improved cementitious mortar with aggregate that had a 28-day compressive strength over 48.3 MPa (7,000 psi) (Figure 7). It was also used to repair grout patches that had been damaged by erosion. Shotcrete was selected for these repairs because it is fast setting, has exceptional

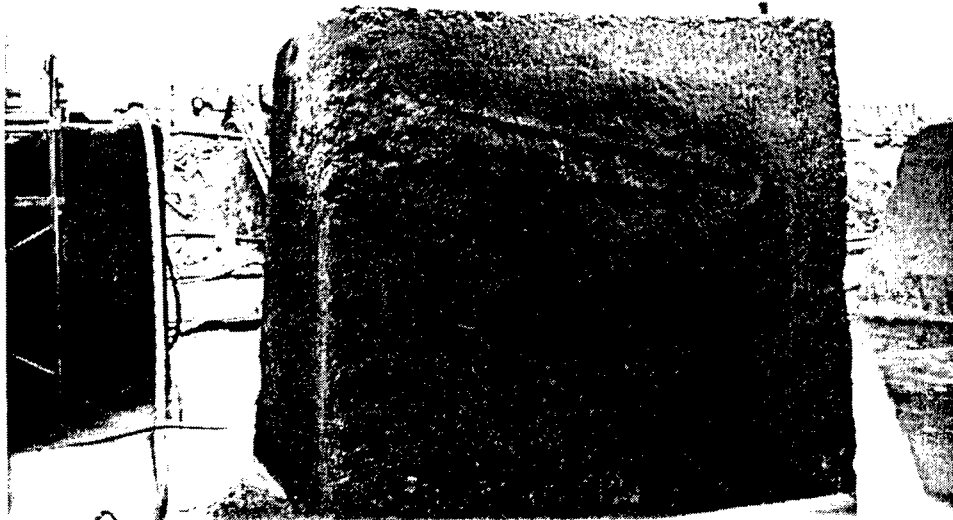

Figure 7. Baffle Block repaired with shotcrete to restore original configuration and halt further erosion, Old River Control Structure (U.S. Army Engineer District, New Orleans 1988)

bonding properties, and has an abrasion resistance six times greater than that of conventional concrete. (Hassenboehler 1988).

When the stilling basin repairs were completed, the contractor began rewatering; however, the procedure was slowed until work on the high bay gate rails on the north side could be finished. The stone dike, risers, and sand closure were removed. The low-sill structure was reopened 14 October 1987, exactly 5 months from the day it was closed (USAED, New Orleans 1988).

The inspection team for the Eleventh Periodic Inspection (USAED, New Orleans 1996) reported numerous spalls around the gate storage slot in the low-sill control structure but recommended no corrective action as the spalls were old and resulted from gate handling operations. Damaged areas were to be monitored on a periodic basis. Concrete in the structure, including the gate monoliths and inflow/outflow training walls, was structurally sound.

## **St. Louis District**

### **Lock and Dam No. 24, Mississippi River**

Lock and Dam No. 24 is located on the Mississippi River at Clarksville, MO, about 150 km (95 miles) upstream from St. Louis. The project, which was constructed in the 1930s, consists of a main lock and upper gate bay of an auxiliary lock, a dam with a moveable section that contains 15 tainter gates, and a fixed submersible stone-covered earth dike that extends from the storage yard to the Illinois shore. Steel pile cells form the core of the dike.

In 1979, Waterways Experiment Station (WES) performed an extensive investigation of selected concrete columns that support the service bridge and piers No. 2 through 15. The purpose of the investigation was to determine the extent and severity of cracking near the trunnion shafts on the downstream portions of the piers and in the columns. The investigation consisted of visual examination, ultrasonic pulse velocity movements, and testing of concrete cores. Stowe and Thornton (1981) reported the investigation and findings and made recommendations for repairs; this case study summarizes their report.

**Investigation of support columns, piers.** The investigation showed that 32 percent of the 64 service bridge support columns were damaged, ranging from very light to severe. Columns representing each of the levels of damage plus four columns that had no signs of deterioration had borings placed in them. Vertical borings were performed in piers where ultrasonic pulse velocity tests indicated poor concrete and where survey data indicated the greatest amount of settlement and downstream movement of the piers had occurred. Short, horizontal borings were also placed in these piers. A marine floating plant was used as a work platform for the drilling operation. A crane on top of the structure was used to move and position the drilling equipment. Once drilling was completed, all borings were backfilled with a mixture consisting of 22.7 kg (50 lb) of packaged dry combined materials plus 4.5 kg (10 lb) of portland cement. An air-entraining admixture was added to the water before it was combined with the dry mixture. After 24 hr, the crown area of backfilled horizontal borings in columns were sealed.

In Pier No. 9, concrete was removed from around the trunnion shaft to expose the tainter gate anchorage steel. The concrete was removed with a hand-held air hammer. There was some rust on the exposed steel, but the amount of damage was considered insignificant. The hole was cleaned, asphaltic bonding material was applied to the anchorage, and then the hole was backfilled with air-entrained concrete.

Cores selected from top, middle, and bottom portions of all vertical cores and intact horizontally drilled cores were sent to WES for testing. Damage consisted of cracking and weathered concrete. Cores and in-place surface concrete were compared. Deterioration in the cores and in the in-place surface concrete matched; this parallel suggested this condition would likely be true even in columns that were not cored.

A petrographic examination of the cores revealed that the concrete was nonair-entrained and that it contained sand and gravel of mixed composition with the maximum size aggregate being 38 mm (1-1/2 in.) Coarse aggregate consisted of sandstone, quartz, chert, and particles of carbonate rock, igneous rock, and ironstone. Chalcedony in the chert particles was identified as the common reactive material. The types of cracking found were typical of that caused by cycles of freezing and thawing and alkali-silica reaction. The concrete was saturated with white alkali-silica gel, which formed a coating on cracks and exterior core surfaces. It was not possible to determine how much of the cracking was caused by freezing and thawing and how much by alkali-silica reaction.

Test results on the cores indicated that the interior concrete in the piers was sound and would serve its original intended purpose. Except for a small zone of damaged concrete downstream of the trunnion shafts on all piers, the lowest compressive strength in the concrete in the piers was about 40.3 MPa (5,840 psi). The compressive strength in the columns was between 6.9 and 13.8 MPa (1,000 and 2,000 psi), the exterior 305 mm (12 in.) having the lower compressive strength. The columns were not weak enough to crumble under static compressive loads; however, the compressive strength would continue to decrease with time if the deterioration of the concrete was allowed to continue. A few fine cracks were found near the trunnion shaft on all piers, a condition that suggested that a portion of the collars on all piers was lightly rusted; however, the damage was not significant to the anchorage steel.

The greatest amount of deteriorated concrete was found on the top portions of the columns. This damage was probably the result of water trapped on top of the columns infiltrating the concrete and then freezing and thawing. Over time, the damaged areas had extended downward, but the concrete near the bottom of the columns was sound. The average depth of damage for the moderately and severely deteriorated columns was 305 mm (12 in.) on the upstream and downstream faces.

The lack of entrained air in the concrete made it more susceptible to frost damage. Once the surface of the concrete was delaminated, alkali-silica reaction accelerated. However, there could have been other causes that were not identified during this investigation, such as vibration of the dam. Support for this theory lies in the fact that the columns on Piers 5, 9, and 16 had more damaged concrete than did the columns on any other piers. Vibration could have caused microcracking at specific locations along the dam. Microcracking, in turn, would have allowed for the beginning of frost damage. Another possible cause of the deterioration was burst pipes. Columns on Piers 9 and 16 had burst pipes; frozen water associated with the pipes could have caused the concrete to split.

Without knowing the basic cause of the problem, those conducting the study could not make definitive recommendations for repairs. They did, however, recommend that all surface cracks on the piers be sealed, especially those in the area of the trunnion shaft. Eliminating the ingress of water into the concrete would prevent the anchorage steel from rusting further and would reduce frost action and alkali-silica reaction.

**Repair plans.** Both an interim repair plan and a major repair plan for the concrete pier columns were outlined. The interim repair plan consisted of implementing modifications for keeping water from entering the concrete: sloping the tops of the columns and cross members so they would drain toward the interior opening between the columns, drilling drainage holes along the lift joint between the columns and column facings, and sealing the top surfaces of the columns and cross members. The crack sealer suggested for horizontal surfaces was a heavy-duty membrane of rubberized asphalt integrally bonded to polypropylene mesh with enough overlap that it could be installed with a mechanical band around the columns to secure it.

The major rehabilitation plan specified removing unsound concrete and replacing it with new air-entrained concrete. No more concrete was to be removed than was necessary to completely expose the outer layer of reinforcing. A high-pressure water jet was recommended for surface removal of deteriorated concrete from piers and bridge columns. The amount of reinforcing steel in the concrete made the water jet preferable to conventional methods of concrete removal; it would leave steel reinforcing clean and undamaged so that it could be reused. Also, the water jet would cause minimal damage to the remaining concrete, it would produce no dust and little noise, and it could be used to remove irregularly shaped concrete. If more than 50 percent of a column area was expected to be removed, temporary support for the column loads were to be provided. It was recommended that replacement concrete be proportioned in accordance with current standard practice and that admixtures to reduce susceptibility to action from freezing and thawing and alkali-silica reaction be added. Also consideration should be given to controlling temperature differences between existing and replacement concrete during placement and curing because of the thermal restraint exerted by the existing concrete. In addition, there should be no more than 14 °C (25 °F) difference between the replacement concrete and the ambient temperature when the forms are removed and immediately afterward.

**Repairs.** Repairs to the trunnion areas and the areas of severest deterioration on the bridge piers were accomplished in 1988. Concrete in the dam was deteriorated in two areas, the columns that support the service bridge over the dam and the pier trunnion areas. Concrete in these areas was cracked extensively, with cracks ranging from hairline to fairly wide. Pier concrete had cracking that ran parallel to the surface concrete. Cracking was attributed to freezing and thawing of nonair-entrained concrete and alkali-silica reaction. Deteriorated concrete in the bridge columns and in the trunnion area on Piers 2 through 16 was removed and replaced, and large cracks were injected with epoxy. Approximately 77.9 cu m (2,750 cu ft) of concrete was removed and replaced from the downstream face of the piers below the trunnion pin. The depth of removal ranged from 0.5 to 1 m (1.47 to 3.39 ft). Approximately 21.4 cu m (756 cu ft) of concrete was removed and replaced on the bridge columns. Maximum depth of these repair areas was 0.17 m (0.55 ft). All of the deteriorated concrete was not removed from the bridge columns because the contractor became concerned about the effect of the removal on the service bridge and the parapet wall on top of the piers. Also, 190.8 lin m (626 lin ft) of cracks were injected with epoxy under this construction contract. An attempt was made to seal the horizontal surface of the piers at el 454 with a modified-methacrylate sealer, but the configuration of the trunnion pin at that elevation and the V-shaped reservoir formed by the pier concrete trapped water and saturated the concrete in the trunnion area, leading to further damage from freezing and thawing.

**Rehabilitation study.** A Major Rehabilitation Study (USAED, St. Louis 1993) performed on Lock and Dam No. 24 investigated the project and made recommendations for rehabilitating the structure with work to be completed during FY98. Economic benefits of the proposed rehabilitation are expected to be realized through reduction in lock closures through more efficient performance and a decrease in future operations and management costs.

The concrete in the piers was investigated through concrete cores, visual inspections, determination of physical properties, and pulse velocity measurements. These investigations determined that a large amount of deteriorated concrete was still present in the bridge columns. Both the concrete and the chert aggregate were cracked in the bridge column on Pier 9. There was also extensive vertical cracking, a result of cycles of freezing and thawing, which decreases the ability of the columns to carry load. Concrete cores taken in the trunnion area did not show sufficient deterioration to require any removal and replacement of concrete in this area. However, it was recommended that a concrete cap be placed over the trunnion pin area to prevent ponding of water to decrease further deterioration from freezing and thawing.

The reliability analysis of the concrete columns that support the service bridge over the dam showed a reliability index of 1.69 for the upstream columns and 1.84 for the downstream columns when the crane carrying the bulkhead was crossing the service bridge above these columns. When the crane was not over them, their reliability index was 2.9 and 3.28, respectively. These reliability indices and the present and future effects of freezing and thawing on the bridge columns indicated that rehabilitation was necessary.

Investigators felt that failure to repair the bridge support columns could result in total collapse of a bridge column. In this event, the crane operator would likely be killed, all power to the tainter gates would be lost because the power line would be severed, the tainter gate in the gatebay where the column collapsed would be seriously damaged. Because of the possibility of such a calamity, use of the crane on the bridge was suspended.

Repair methods considered for rehabilitating the concrete bridge supports included epoxy injection, encasement, and removing and replacing the deteriorated bridge support columns. The epoxy injection repair method was rejected because of the lack of success with this method at Lock and Dam No. 20, USAED, Rock Island. The encasement method which would have consisted of building a steel box around the deteriorated columns, was rejected because there was no known application where it has been successful. The method selected was to remove the deteriorated concrete bridge support columns on Piers 2, 4, 5, 6, 8, 9, 10, and 16 and replace them. The service bridge would remain in place during the replacement; a temporary frame would be fabricated to support the bridge over the pier being rehabilitated. The trunnion area on Piers 2 through 16 would also be capped with concrete to keep water from pooling in the V-shaped area above the trunnion pin.

At the time of the Tenth Periodic Inspection (USAED, St. Louis 1997), the removal and replacement of columns on six of the eight bridge piers approved in the 1993 Major Rehabilitation Report were underway. Two of the columns that support the service bridge at Pier 16 had been removed. The periodic inspection team examined them and found excessive cracking, especially toward the top of the columns (Figure 8a). Generally, the concrete in the columns was in poor condition (Figure 8b).

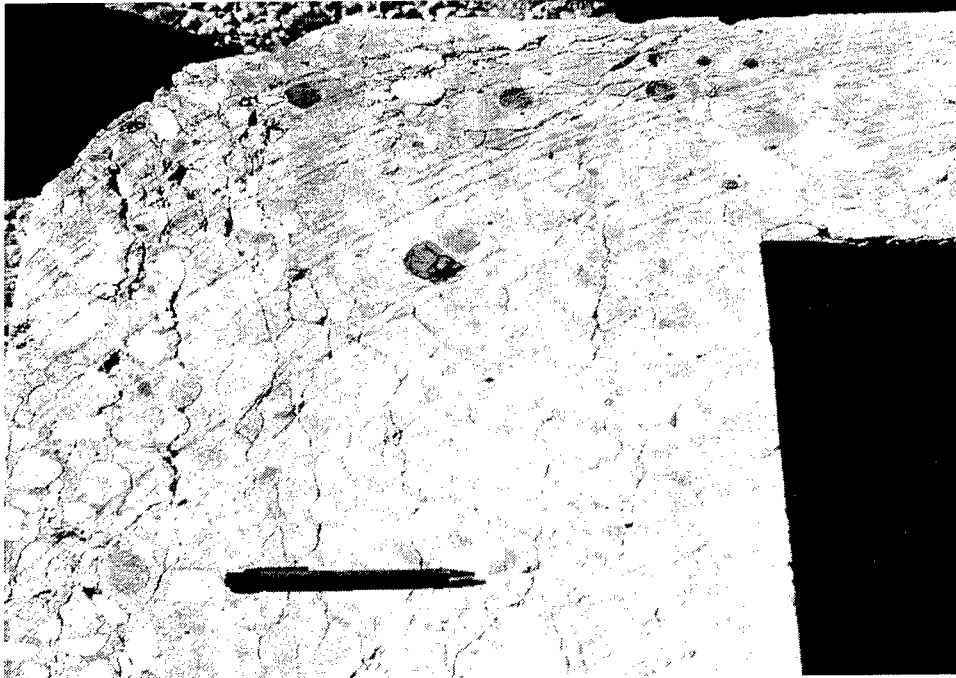

- a. Interior cracking in concrete on Pier 11 removed for replacement, Mississippi Lock and Dam No. 24 (from U.S. Army Engineer District, St. Louis 1997)

Figure 8. Cracking and deterioration of concrete, Mississippi River Lock and Dam No. 24

The inspection team was recommended that the District Materials Engineer inspect the columns as they were removed to determine the severity of the deterioration. This inspection indicated conditions were as bad as believed; therefore, the team recommended that Piers 4 and 5, which were approved in the 1993 Major Rehabilitation Report but which had not been funded, be replaced. The recommendation was approved, and these piers were to be replaced under the current contract.

The vertical cracks on both sides of the dam piers that were noted in 1993 did not appear to be opening. The inspection team recommended that the piers be sealed to reduce water seepage into the piers as soon as possible and to continue visual monitoring for further deterioration caused by freezing and thawing. Based on this recommendation, workers began the process of capping the lower areas of Piers 2 through 15 with 203 mm (8 in.) of reinforced concrete. The concrete cap, Pier 9, will function as a floating slab to reduce reflective cracking (Figure 8c). This work is also scheduled for completion during FY98.





Figure 8b. Severely deteriorated concrete in bridge support column from Pier 11, Mississippi Lock and Dam No. 24 (from U.S. Army Engineer District, St. Louis 1997)

### **Wappapello Dam**

The Wappapello Dam project, which was constructed in the 1940s, is located on Wappapello Lake on the St. Francis River near Poplar Bluff, Missouri. Between construction and 1986, the emergency spillway was overflowed once.

An inspection of the project revealed areas of concrete deterioration in the stilling basin floor, on baffle blocks, and on the end sill. Some of the reinforcement in the stilling basin floor was exposed. Concrete in the emergency spillway contained numerous cracks, and monolith-joint material had eroded away. Repairs were made to the stilling basin and emergency spillway in 1986.

So that repairs to the stilling basin could be made in the dry, flow through the spillway had to be rerouted. A bulkhead was constructed above the basin and flow was directed over the basin through a 1067-mm (42-in.) corrugated metal pipe. Prior to placement of a 76-mm (3-in.) concrete overlay on the stilling basin floor, the surface was cleaned with high-pressure water blasting, and an epoxy was spread over the surface to bond the overlay to the existing concrete. The stepped end sill was changed to a slope so rocks could be washed from the basin. Baffle blocks were repaired with an epoxy mortar; however, all of the

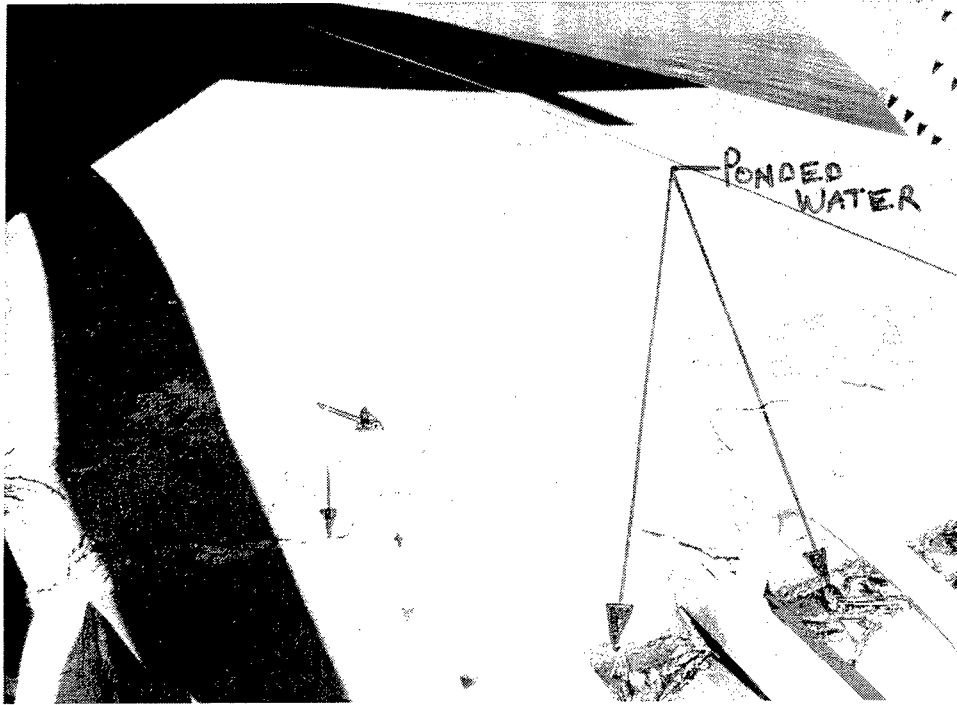

Figure 8c. Lower area of Pier 9 to be capped with floating concrete slab, Lock and Dam No. 24, Mississippi River (from U.S. Army Engineer District, St. Louis 1997)

mortar did not bond to the existing concrete, and the repairs were not completed before the basin was reopened.

The major cracks in the emergency spillway were injected with epoxy, and epoxy mortar was used to repair spalls and holes in the surface. Monolith joints were resealed with a silicone joint sealant. So that work could continue during the winter months. The work areas were temporarily enclosed.

A follow-up inspection was conducted in March 1991. The overlay in the stilling basin was in excellent condition, and the epoxy mortar that had bonded to the baffle blocks was still intact. In the emergency spillway, the epoxy injected into cracks was performing satisfactorily, and the joint sealant was in excellent condition. However, the epoxy mortar repairs were debonding and cracking.

## Omaha District

### Oahe Dam

The Oahe Powerhouse is a part of the Oahe Dam project at Pierre, SD. In 1977, sport divers sighted concrete damage in the tailrace slab of the powerhouse. This revelation led to further investigation and the discovery of spalling

not only in the tailrace slab, as the divers had reported, but also at its junction with the powerhouse draft tube and in units 4 and 5 of the draft tube portals. Downstream of Unit 1, a large area of spalling was found on the slab where it tapers to a thickness of 0.3 m (1 ft).

The cause of the spalling has been attributed to rebounding of the underlying shale formation. The end of the tailrace slab, which was not anchored, had raised up to 0.9 m (3 ft) in the center sections as a result of the rebounding. Spalling likely began when concrete at the interface of the powerhouse and the tailrace slab started moving together. Reinforcement in the slab was placed in one continuous segment, so there was no allowance for movement between the concrete sections. Also, the tailrace slab was placed against the draft tubes without an expansion joint.

Repairs were made to the tailrace slab and the downstream edge of the draft tubes between September 1978 and January 1979. A second contract, begun in October 1979 and ending in January 1980, was for epoxy resin repair of additional spalls on the downstream edge of the draft tube. All repairs were made underwater because the expense of dewatering plus estimates for revenue lost from power production were considered to be too costly.

The damage on the tailrace slab was repaired with grouted preplaced aggregate. The first step in the repair was to chip out loose and drummy concrete, and then remove some sound concrete to shape the area for repair. Next, the area was cleaned with air-water jets, and the aggregate was placed. A steel form was bolted over the aggregate, and then the aggregate was grouted with a standard concrete grout that included an expanding agent. The consensus was that the preplaced aggregate repair was better than a tremie concrete repair would have been. A saw cut was made in the tailrace slab just downstream of the interface to relieve pressure. Spalls at the downstream edge of the tailrace slab were repaired with epoxy grout resin. Divers placed the epoxy by hand and then covered it with a steel plate until it cured. Approximately 4,012 l (1,060 gal) of epoxy grout was used for these repairs. Water temperature was approximately 10 °C (50 °F) during repairs. The repairs proved to be quite successful when the epoxy had more than 12 hr to cure before the turbine involved was restarted. Underwater TV cameras were used for monitoring the repairs.

During the 1980s, the repairs were monitored periodically by divers. By the late 80s, spalling had become active and was moving close to the seal plate. Should spalls undermine the seal plate, the downstream stop logs would not seal. In 1990 to 91 diving inspections were performed to determine the size of the damaged area. Divers took core samples to ascertain the depth of laminations and the condition of the concrete.

An underwater repair plan based on similar repairs performed at Gavins Point Dam, Yankton, SD, (Harris, Palmer, and Miller 1991) and technology published by the REMR Research Program (McDonald 1990) was selected. Spalls would be repaired with preplaced aggregate; anchored steel plates would serve as a

form for the aggregate. The contract bid was \$469,450.00; the length of the contract was 120 days, with the powerhouse shutdown limited to 28 days.

Anchors for the steel plates were installed with vinylester resin in a two-step procedure developed by Hilti, Inc. (McDonald 1990). A small amount of adhesive was injected into the bottom of the drill hole, and then paired cartridges, one containing vinylester and the other a hardener, were dispensed into the hole with a tool that resembled a caulking gun. The anchor was spun into the hole, breaking the cartridges and mixing the epoxy, and displacing the remainder of the water. Twelve hundred forty-seven holes were drilled to anchor the steel plates, which weighed 1,103 kg (2,430 lb) each.

Steps in the repair procedure were to install anchors around a repair area, remove drummy concrete, hydroblast the area to remove all debris, place the aggregate, install the steel plates, and then inject the grout under pressure to displace water in the aggregate voids. Grout was cured for a minimum of 24 hr before the next anchor holes could be drilled. The area between the sill plate and the interface of the tailrace slab was covered with steel plates. Just downstream of the interface on the tailrace slab, 305-mm- (12-in.-) wide plates were used.

The repairs were done at a depth of 10 m (33 ft) in water that ranged from 13 to 17 °C (56 to 63 °F). Divers worked in two 12-hr shifts, with 15 divers per shift. The contractor completed the project 4 days early, earning \$18,000 per day as a bonus for early completion. The final payment was \$524,354.50.

## **Baltimore District**

### **Indian Rock Dam**

Indian Rock Dam is located in York, PA, about 213 m (700 ft) above the confluence of the Main Branch and the South Branch of Codorous Creek. The dam, which was constructed between 1940 and 1942, is part of Codorous Creek flood protection. It is a rolled earth-fill embankment with a rock facing. The crest, without the spillway, is 305 m (1,000 ft) long and 25.3 (83 ft) above the streambed. The spillway crest is at el 425.5. The dam does not confine a permanent lake and has impounded floodwater only twice.

Cores taken during an inspection of the concrete spillway revealed areas of deteriorated concrete at locations near the surface to depths up to 0.6 m (2 ft). The cores, which were well consolidated, nonair-entrained concrete, showed no signs of segregation. Fractures and cracks generally ran parallel to subparallel to the tops of the cores. Bond between the concrete and reinforcing steel and between concrete and the bedrock interface was intact. Laboratory tests showed concrete deeper than 0.6 m (2 ft) had a compressive strength greater than 24.8MPa (3,600 psi). The conclusion, based on the pattern of fractures and cracks, was that the deterioration resulted from cycles of freezing and thawing.

Repairs were scheduled for 1993. Deteriorated concrete was removed down to sound concrete, and then an inspection was made to ensure there were no isolated areas of deterioration below the estimated depth. After the surface was cleaned by sandblasting, it was flushed with water. No. 6 reinforcing bars were installed on 1.2-m (4-ft) centers to anchor the replacement concrete facing to the existing concrete and for aligning new reinforcing steel in the new concrete. The new reinforcing consisted of a mat of No. 6 reinforcing bars on 305-mm (12-in.) centers. A minimum 127 mm (5 in.) of cover was maintained. Type II air-entrained concrete was used as the replacement concrete.

The same procedure was used for replacement of deteriorated concrete surfaces for the weir and spillway walls and floor.

### Little Falls Dam

Little Falls Dam is located on the Potomac River between Virginia and Maryland just west of Washington, DC, in a section of the river that is a very popular recreational site. The dam was constructed to direct flow to the pumping station that supplies the nation's capital with water. It is a 426.7-m- (1,400-ft-) long low-impoundment dam with two pools. Depending on the season, the water level between the pools typically varies from 0.3 to 0.9 m (1 to 3 ft). It has an ogee downstream face and a 0.6-m- (2-ft-) high hydraulic jump at the toe of the apron. This configuration was designed to dissipate hydraulic energy and reduce erosion; however, remnants of a rock crib dam built in the 1830s blocks the free flow of tail-water below Little Falls, raising the elevation of the lower pool. In periods of very heavy flow, when 0.9 to 1.5 m (3 to 5 ft) of water crest the dam, a strong roller, or undertow, condition is created (Figure 9). Between 1975 and 1983, 17 people drowned in the vicinity of the dam. Rafting or canoeing near or over the dam, they were caught in the undertow and submerged. Seeking to prevent further loss of life, the USACE began looking for solutions for this problem (Davis and George 1985).

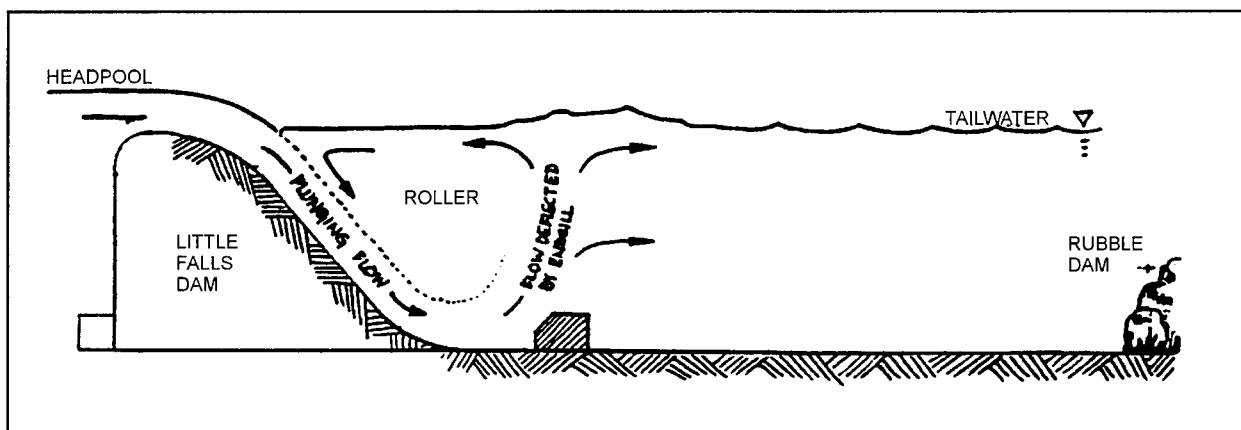

Figure 9. Cross section of Little Falls Dam, showing typical flow conditions below the dam (from Davis and George 1985)

The most obvious solution was to remove the remnants of the rock crib dam, which was originally constructed to divert water into the Chesapeake and Ohio Canal, but the dam could not be removed because of its historic features. The USACE began model testing various alternatives for eliminating the roller. The alternative selected was to use grout-filled bags to create a 3:1 stepped slope that would extend about 6 m (20 ft) beyond the toe of the apron (Davis and George 1985). Figure 10 shows the alternative design.

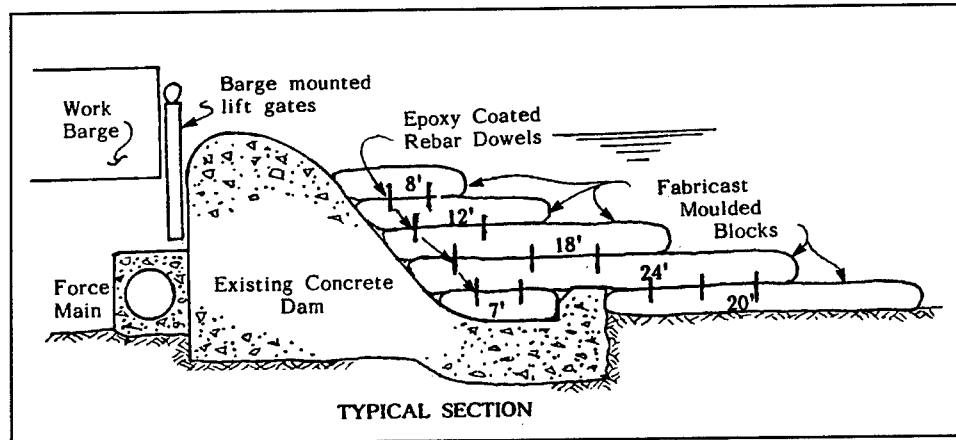

Figure 10. Plan for placement of grout-filled bags to eliminate the roller at Little Falls Dam (from Intrusion-Prepakt, Inc. 1986)

Prepakt Concrete Company was low bidder for the project. The company had to comply completely with National Park Service (NPS) rules. To meet NPS regulations, the contractor had to fence off the work area, construct washout ponds with tarp linings for easy cleanup for haul trucks, provide protection for trees, and construct a 487.7-m- (1,600-ft-) long service road to access the work area. The stone-surface service road was built on a heavy filter fabric so it could be completely removed upon completion of the project. Where the access road crossed the Chesapeake and Ohio Canal, a 2.7-m- (9-ft-) diam metal culvert was installed to prevent interruption of canoe traffic on the waterway (Intrusion-Prepakt 1986).

Barges were equipped to serve as floating work stations. To provide calm water for the divers, work barges were fitted with adjustable deflection gates. Once the barges were in place, a crane would lower the deflection gates into position to divert river flow around the work area (Figure 11).

Grout was mixed at an off-site batch plant and delivered to the work site in transit-mix trucks. It was pumped to the barges through a 64-mm (2-1/2-in.) flexible line. Spacing frames especially designed for this project (Figure 12) were used to position the grout bags. The cranes were used to lower the frames into the water. Workers on floating barges began installing the grout bags from the end of the dam, working toward the center. Grout bags were inflated with grout until they were 0.6 m (2 ft) thick, 1.8 m (6 ft) wide, and up to 7.3 m (24) ft long (Figure 13). Each tier of bags was anchored to the previous tier with epoxy-coated rebars.

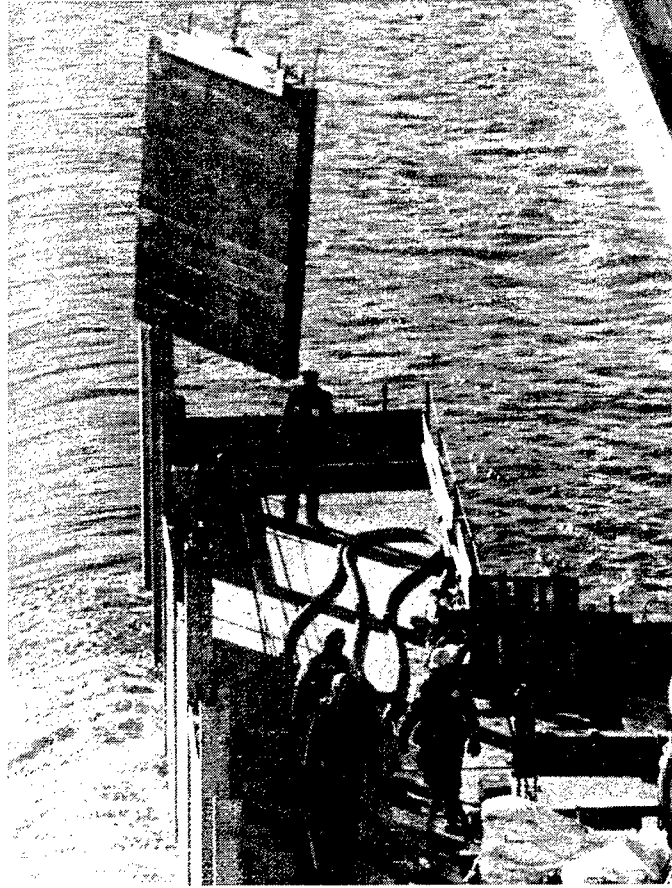

Figure 11. Work barge with raised deflection gate, Little Falls Dam (from Intrusion-Prepakt, Inc. 1986)

The project actually began in mid-December of 1985 and was completed March 1 on schedule. The contractor worked continuously 7 days a week, even when there was ice on the river or heavy flooding. Monday through Friday, he was restricted by NPS regulations that did not permit commercial traffic in the area before 9:30 A.M. or after 3:30 P.M. There were no restrictions on the weekends. The modifications to Little Falls Dam successfully eliminated the undertow problem.

To complete the project, the contractor had to restore the area to its original condition, leaving no signs that a major project had ever been performed there. In addition to removing about 5,443 Mg (6,000 tons) of stone, the canal crossing and the service road, he had to plant 500 new trees and shrubs under NPS direction (Intrusion-Prepakt 1986).

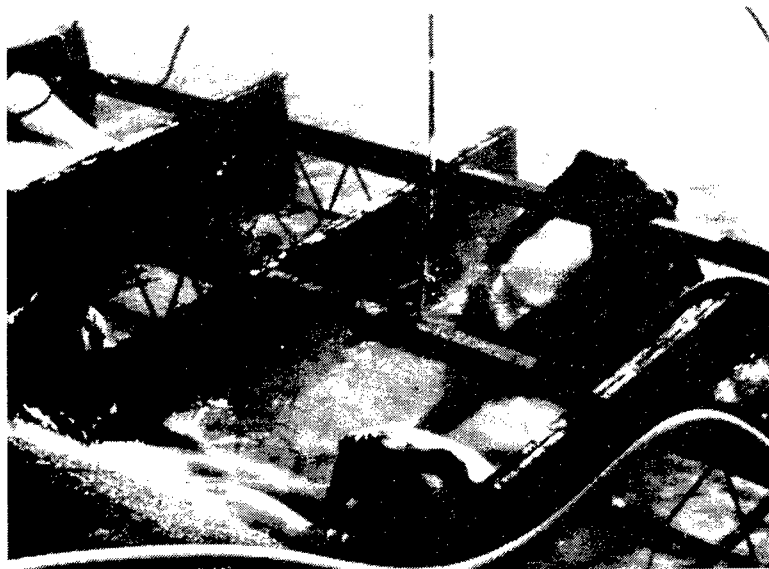

Figure 12. Spacing frame used for placing grout-filled bags at Little Falls Dam (from Intrusion-Prepakt, Inc. 1986)

## New York District

### Troy Lock and Dam

Troy Lock and Dam is located on the Hudson River near the city of Troy, New York. The dam, a 396-m- (1,300-ft-) long concrete gravity overflow structure, has a 178.6-m- (586-ft-) long section with el 14.33 and a 217.6-m- (714-ft-) long section with el 16.33. A 59.4-m- (195-ft-) long gated structure is located at the western end of the dam at the flume to the Niagara Mohawk Power Corporation powerhouse, and a 7.6-m (25-ft) ice-pass spillway is adjacent to the gated structure. Completed in 1915, the dam, which is founded on bedrock, was constructed with nonair-entrained concrete and river gravel aggregate.

During the initial stages of an inspection of the dam in the mid-1980s, several types of deterioration were noted: cracking in the concrete on the piers that support the gated structure and in the dam tunnel access shaft at construction joints, scour holes at the toe of the dam, and several voids under the concrete sill. The cracks were caused by stress from ice and debris lodging on the structure during high river flows; cracks in some construction joints were large enough that a considerable amount of water flowed through them. Scoured areas at the base of the dam were caused by turbulent water.

The dam was repaired during the summer months between 1988 and 1990. Cracked concrete on top of the piers was removed to sound concrete and replaced with air-entrained, reinforced concrete. Dowels were used to anchor the new concrete to the existing concrete. Following placement, the concrete





Figure 13. Inflated grout bags installed; spacing frame removed (from Intrusion-Prepakt, Inc. 1986)

was protected with curing sheets and cured with water for 7 days. Cracks in the dam access were sealed with a moisture-reactive, polyurethane chemical grout that helped control leakage. Original specifications had called for a cementitious grout, but because water was flowing at several grout repair areas, the contractor elected to use the polyurethane grout as it could be applied in wet conditions. No structural repairs were made to the cracks because the contractor was not certain about the distribution of stress through the crack-repair area. Scoured areas were filled with tremie concrete, pumped from shore. Specifications for the concrete called for a minimum of 431 kg/cu m (727 lb/cu yd) of cement; w/c ratio of 0.45 by weight; a maximum slump of 203 mm (8 in.), and a compressive strength of 27.6 MPa (4,000 psi). The scoured holes were examined and cleaned, if necessary, by a diver prior to placement of the concrete. Water flow over the dam was diverted during concrete placement and for a minimum of 24 hr after placement.

A follow-up inspection indicated repairs to the piers, the spalled areas, and cracks in the shafts and tunnels were performing as expected. However, crack repair in the access shaft was not completely effective because the large amount of water flowing through one area prevented the grout from curing properly.

Cost of repairs to the piers was \$89,585, which included \$35,750 for 84 cu m (110 cu yd) of concrete; \$9,835 for 4,461 kg (9,835 lb) of reinforcing; and \$44,000 for removal of 84 cu m (110 cu yd) of concrete. Mobilization and

demobilization of equipment were included in these costs. Total cost for crack repair in the access shaft was \$5,520, including labor, materials, and equipment. Preparatory work for repairing scour holes, which consisted of equipment and driving sheet piles along the dam, was \$150,000. The cost for 363 cu m (475 cu yd) of tremie concrete was \$89,375.

## **Detroit District**

### **Menasha Dam**

Menasha Dam is located on the Fox River in Menasha, WI, at the outlet of Lake Winnebago. Built on a soil foundation, the 121-m- (400.5-) ft-long dam has a 75-m- (246.5-) ft-long uncontrolled, ogee-shaped gravity section that serves as a spillway and a 47-m- (154-ft-) long sluiceway with six tainter gates. The dam holds a 3-m (9.7-ft) head. It was constructed in 1937 to control the level of Lake Winnebago. Through the years, cycles of freezing and thawing caused concrete deterioration on the face of the spillway and sluiceway piers. This damage was repaired in the summer of 1985.

All areas to be repaired were dewatered, and then the deteriorated concrete was removed with jackhammers to a maximum depth of 0.3 m (1 ft). Anchors were installed to tie the new concrete to the existing concrete, and an epoxy adhesive was applied to the existing concrete as a bonding material. Welded-wire fabric was used to restore the repair to the original geometry of the structure. The replacement concrete had a compressive strength of 41.4 MPa (6,000 psi). A spray-on compound was used for curing.

During curing, hairline cracks, which were attributed to drying shrinkage, appeared in the new concrete. The contractor reportioned the replacement concrete to have a compressive strength of 27.6 MPa (4,000 psi) and stopped using the epoxy adhesive bonding material.

An inspection of the dam in October 1989 revealed that the repaired areas were still sound.

## **Rock Island District**

### **Brandon Road Dam**

Brandon Road Dam is located on the Des Plains River at Rockdale, IL. The 478.2-m (1,569-ft) gated concrete structure is connected to an earthen embankment on the right abutment and a concrete channel wall on the left. The channel wall is a concrete gravity structure that ranges from 4.6 m to 12 m (15 to 40 ft) high; it extends upstream about 1.86 km (3 miles). The original dam had a 97.5-m (320-ft) head gate section, a 9-m (30-ft) ice chute, a 27.7-m (91-ft) sluice

gate section, and a 338-m (1,110-ft) tainter gate section. Completed in 1933, the dam was constructed of unreinforced, nonair-entrained concrete. Primarily because of the lack of air-entrainment, concrete in the lock, the dam, and the walls sustained damage from cycles of freezing and thawing.

The structure was repaired in five stages between 1984 and 1988, with major rehabilitation performed in 1986 and 1987. The lock was rehabilitated during the first two stages, and the channel wall was repaired with precast concrete panels during Stages IV and V. The dam was rehabilitated during Stage III.

The tainter gate section consists of twenty-one 15-m- (50-ft-) wide gates separated by adjacent 1-m- (3-ft-) wide piers. Rehabilitation of this section included replacement of 13 gates, repair of 8 gates, replacement of hoisting mechanisms, replacement of side and sill seals, and resurfacing of the upstream portion of 11 piers. On the upstream portions of the piers, deteriorated concrete was removed to a depth of approximately 203 mm (8 in.). Replacement concrete was conventionally placed air-entrained concrete anchored with No. 6B bars and reinforced with No. 6 steel bars at 305 mm (12 in.) each way. A steel angle was embedded at the upstream bullnose of the piers.

The head gate section consists of sixteen 4.6-m- (15-ft-) wide gates. At the time of rehabilitation, six of the gates were operational. Rehabilitation consisted of sealing eight head gate openings with concrete, modifying eight head gate openings to accommodate new gates, and repairing concrete on the upstream, downstream, and horizontal surfaces of the head gate section.

The District had decided to use preplaced aggregate concrete (PAC) to close all eight gates; however, the low bid contractor wanted to use conventional concrete. The compromise was to use PAC for four of the openings and conventional concrete for four. Conventionally placed, air-entrained concrete with a 27.6 MPa (4,000 psi) was used to seal head gates 3, 4, 7, and 8. Delays during the placement of the first three truckloads of concrete used to seal head gate openings 7 and 8 resulted in slump loss in the waiting fourth and fifth loads. Although loads four and five were subsequently rejected, some of the stiff concrete was placed in an effort to avoid a cold joint. After the forms were removed, cold joints and areas of honeycomb were visible. Pulse velocities were determined, and several cores were taken to evaluate the integrity of the concrete. Concluding that most of the honeycomb areas were near the surface, the contractor decided to patch the areas. No problems were encountered during the placement of concrete in head gate openings 3 and 4.

Head Gates 1, 2, 5, and 6 were sealed with PAC. The coarse aggregate was crushed limestone, 38 mm to 19 mm (1-1/2 to 3/4 in.) in diameter, that was screened and washed at the site just before it was placed in the forms. The grout was mixed at the site. Each batch of grout had a yield of 0.17 cu m (6 cu ft). The contractor was allowed to use horizontal, rather than vertical, grout pipes for grouting the PAC. The grout was injected through holes on 0.6-m (2-ft) centers. The 19-mm (3/4-in.) grout pipe was inserted in the lowest hole in one corner of the forms. When good grout flow was noted from adjacent holes, the grout pipe

was removed and a wooden dowel was driven into the hole. The grout pipe was then inserted into an adjacent hole until grout again flowed through adjacent holes. This process was continued until the forms were completely filled. The performance of the PAC was more satisfactory than that of the conventional concrete from the standpoint of shrinkage cracking. The rehabilitated downstream face of the head gate section is shown in Figure 14.

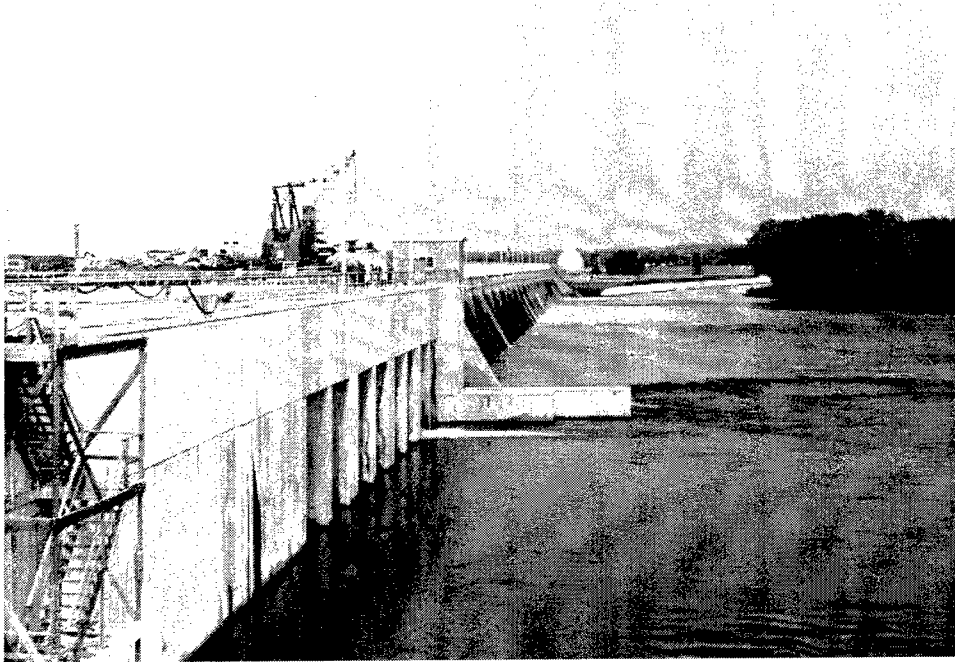

Figure 14. Head gate section of Brandon Road Dam after rehabilitation

Concrete was removed to a depth of 229 mm (9 in.) on the horizontal surfaces of the head gate section. No. 6 steel bars at 305-mm (12-in.) spacings each way provided reinforcing for the horizontal surfaces of the head gate section. Additional reinforcing was added across the openings in the existing concrete. An asphaltic bond breaker was applied to the existing concrete before the conventional air-entrained concrete overlay was placed (Figure 15). Repair to the horizontal deck of the head gate section was similar to that of the sides; a 229-mm- (9-in.-) thick, unbonded overlay was used to replace deteriorated concrete (Figure 16).

The sluice gate section had six gates, which were inoperable. These gates were sealed as a result of the increase in discharge capacity that resulted from the rehabilitation of the head gate section. A value engineering proposal to use gates removed from the head gate section as the upstream form and to use the in-place sluice gate as the form for the downstream face was adopted. A waterstop was installed around the perimeter of the opening. Reinforcing steel consisted of two mats of No. 8 bar on 229-mm (9-in.) centers each way. A 0.30-m- (1-ft-) thick concrete slab was placed in the sluice gate slots and the entire surface was overlaid with 51 mm (2 in.) of latex-modified concrete. The latex-modified



Figure 15. Head gate section on upstream face at Brandon Road Dam after rehabilitation



Figure 16. Repairs to the horizontal deck of the head gate section at Brandon Road Dam

concrete was mixed on a barge, loaded into Georgia buggies, and transported to the placement site. A grout mixture of cement, sand, water, and latex modifier was scrubbed into the existing concrete surface just before the overlay was placed. Wet burlap and polyethylene sheeting were used to moist cure the concrete for the first 24 hr. The overlay was then air-cured for 3 days before being opened to traffic.

The materials and placement procedures used to resurface the sluice gate section were used to rehabilitate the ice protection wall, which extends from the boiler house pier to the upstream end of the upper guide wall of the lock. A new bridge was constructed across the ice chute section.

The boiler house monolith was extensively modified. Rehabilitation included removal of a large portion of the downstream section, resurfacing vertical and horizontal surfaces, and filling existing openings. Conventional concrete was used, and a new metal maintenance building was erected on top of the rehabilitated monolith (Figure 17).

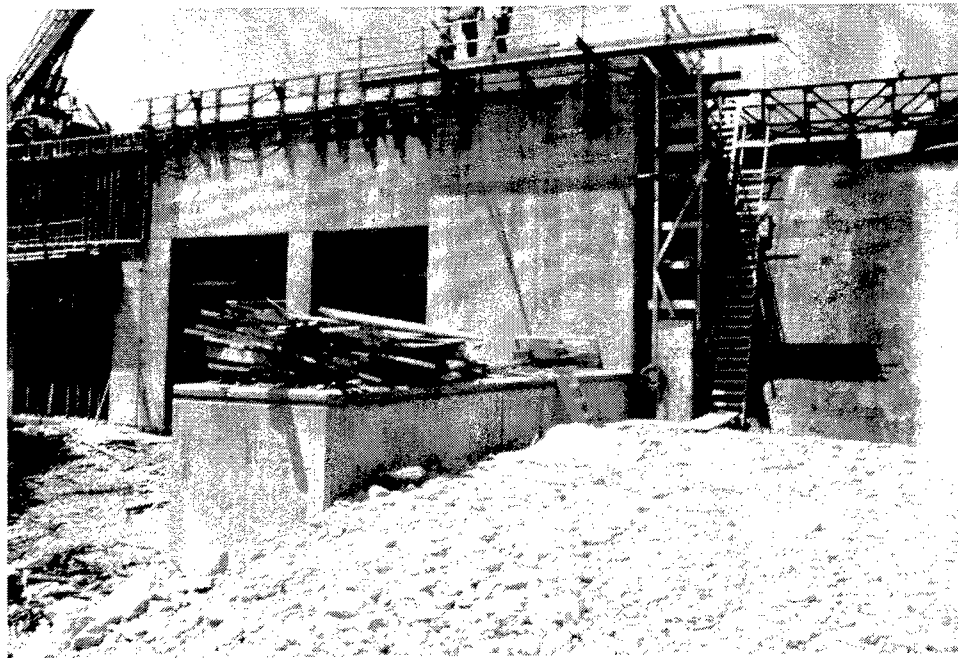

Figure 17. Boiler house after rehabilitation, Brandon Road Dam

A follow-up inspection indicated all repaired areas on the project are performing satisfactorily, even though all surfaces have experienced minor shrinkage cracking.

Unit costs for the repairs were as follows: concrete removal, \$26 per cu m (\$20 per cu yd); concrete anchors, \$42 each; concrete, \$654 per cu m (\$500 per cu yd); latex concrete, \$916 per cu m (\$700 cu yd); and precast concrete, \$300 per sq m (\$27 per sq ft) (Doak 1988).

As a result of this project PAC was specified for resurfacing Peoria lock wall.

The sixth periodic inspection team (USAED, Rock Island 1992) found the concrete on the head gate, sluice gate, and boilerhouse portions of the dam to be in good condition.

### **Dresden Island Lock and Dam**

Dresden Island Lock and Dam is located immediately downstream of the junction of the Des Plaines and Kankakee Rivers, approximately 13 km (8 miles) northeast of Morris, IL. The lock is 33.5 m (110 ft) wide and 183 m (600 ft) long; it has a lift of 66.3 m (21.75 ft). The concrete dam, which is 290 m (950 ft) long, is founded on rock. It consists of a 189-m (620-ft) tainter gate section, a 91-m (300-ft) head gate section, a 9.1-m (30-ft) ice chute section, a 33.5-m (110-ft) arch dam, and a 11.4-m (37.5-ft) fixed dam section.

A 1980 inspection of the 47-year-old dam revealed severe deterioration of the concrete as a result of years of being subjected to cycles of freezing and thawing and impact and abrasion. Hydraulic studies conducted as part of the evaluation of the dam indicated that the head gate section was not required for discharge of water; therefore, the construction of closure panels for this section became a part of the rehabilitation plans. Additional work done in 1981 included resurfacing the arch dam abutments and the tainter gate piers and modifying the ice chute. Conventional, air-entrained concrete with a compressive strength of 27.6 MPa (4,000 psi) was used in all repairs. Vibrators were used to consolidate the concrete, and a curing compound was used for curing.

The head gate closure panels were installed on the downstream face of the structure. The panels, which were 4.6 m (13 ft 4 in. ) wide, 4.9 m (16 ft) high, and 1.2 m (4 ft) thick, were reinforced with No. 6 steel bars on 305-mm (12-in.) centers each way on both faces. No. 6 steel bars on 457-mm (18-in.) centers vertically were used to anchor the panels to the existing piers. Anchors were also installed at the bottom of the panels (Figure 18). The head gate section after rehabilitation is shown in Figure 19.

Deteriorated concrete in the roof of the head gate opening was removed, and grout was troweled on to provide a smooth surface. The surface was then painted with bituminous mastic. A waterstop was installed along the horizontal joint at the top of the closure panel.

Ready-mix trucks delivered the concrete to the site from a plant about 13 km (8 miles) away. The trucks were driven onto the head gate section and discharged the concrete directly into the forms.

Rehabilitation of the tainter gate section primarily consisted of removing and replacing 229 mm (9 in.) of concrete and installing new gate seal plates along the sides of the piers. The vertical and horizontal resurfacing was anchored to the existing concrete with No. 6 B anchors, 0.6 m (2 ft) on center both ways. The

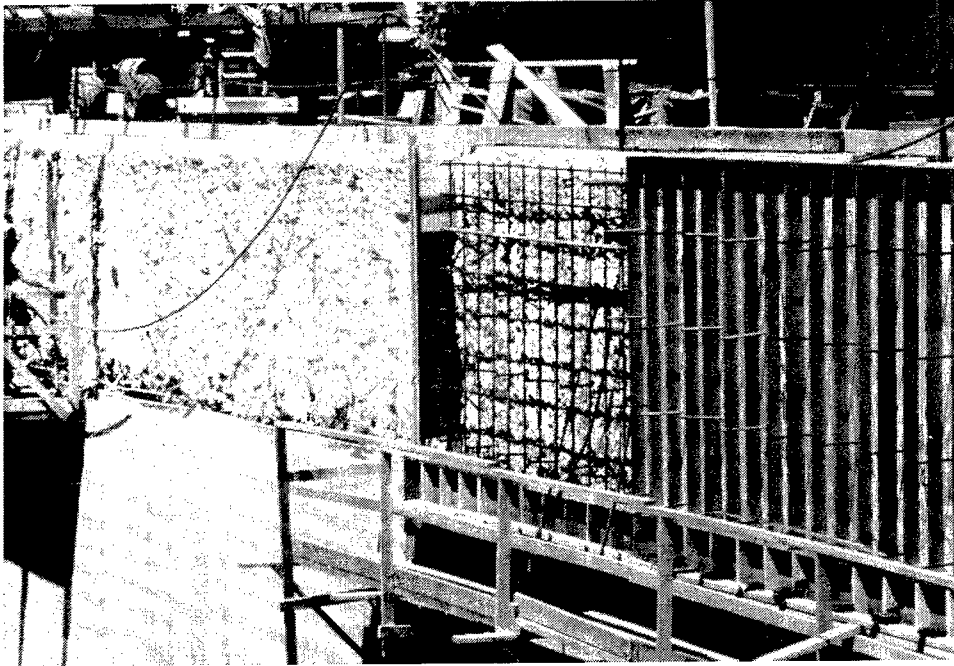

Figure 18. Reinforcing and forms for head gate closure panels at Dresden Island Lock and Dam



Figure 19. Downstream face of head gate section after rehabilitation, Dresden Island Lock and Dam



resurfacing was reinforced with welded wire fabric. Ready-mix trucks were transported by barge to the tainter piers. A crane and a bucket were used to place the concrete. Other work included modification of concrete to accommodate new bridge bearing details.

The procedure for resurfacing the arch dam was similar to that used for the tainter gate section. Concrete removal on the arch section varied from 229 mm to 0.38 m (9 in. to 1 ft 3 in.). Line drilling, expansive grout, and chipping hammers were used to remove the deteriorated concrete (Figure 20). The arch dam after rehabilitation has been completed is shown in Figure 21.

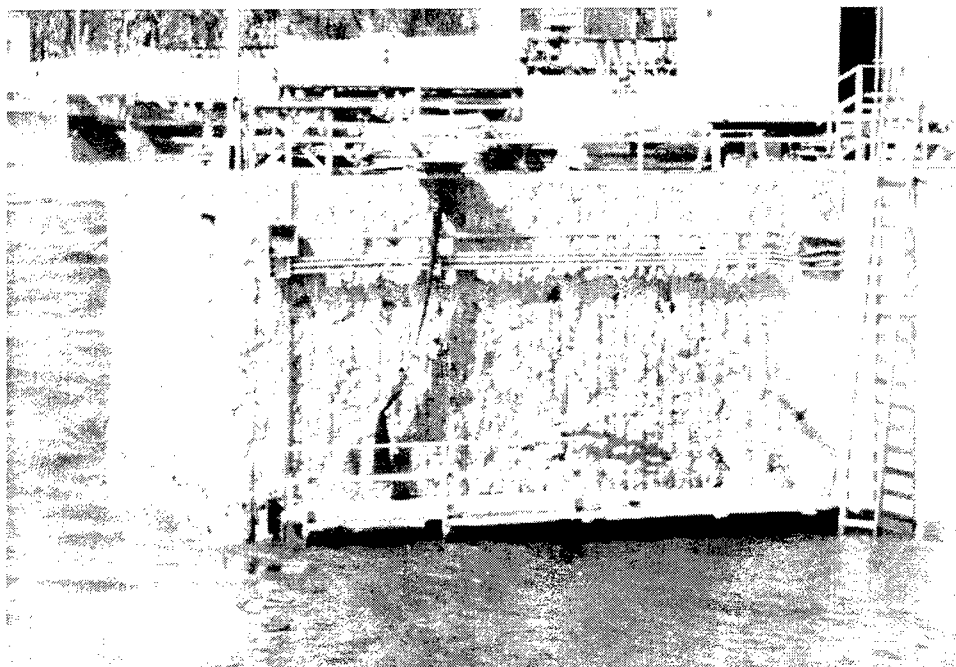

Figure 20. Concrete removal and anchors for the arch dam at Dresden Island Lock and Dam

The gated ice chute was converted to an uncontrolled ogee crest. Concrete was removed, forms were built, and the concrete replaced to obtain the ogee configuration (Figure 22). The converted ice chute is shown in Figure 23. The downstream face of the gate sill was resurfaced, and the gate recess in the sill was filled with concrete. The same methods were used to resurface this section as had been used on the arch dam.

Proportions for concrete used in the rehabilitation work consisted of 293 kg per cu m (494 lb per cu yd) of Type I cement, 843 kg per cu m (1,420 lb per cu yd) fine aggregate, 1,033 kg per cu m (1,740 lb per cu yd) coarse aggregate, 147 kg per cu yd (247 lb per cu yd) water, 0.2 ℓ per cu m (5 oz per cu yd) of air-entraining admixture, and 0.6 ℓ per cu m (14.8 oz per cu yd) water-reducing admixture.



Figure 21. The south abutment of the arch dam after rehabilitation, Dresden Island Lock and Dam

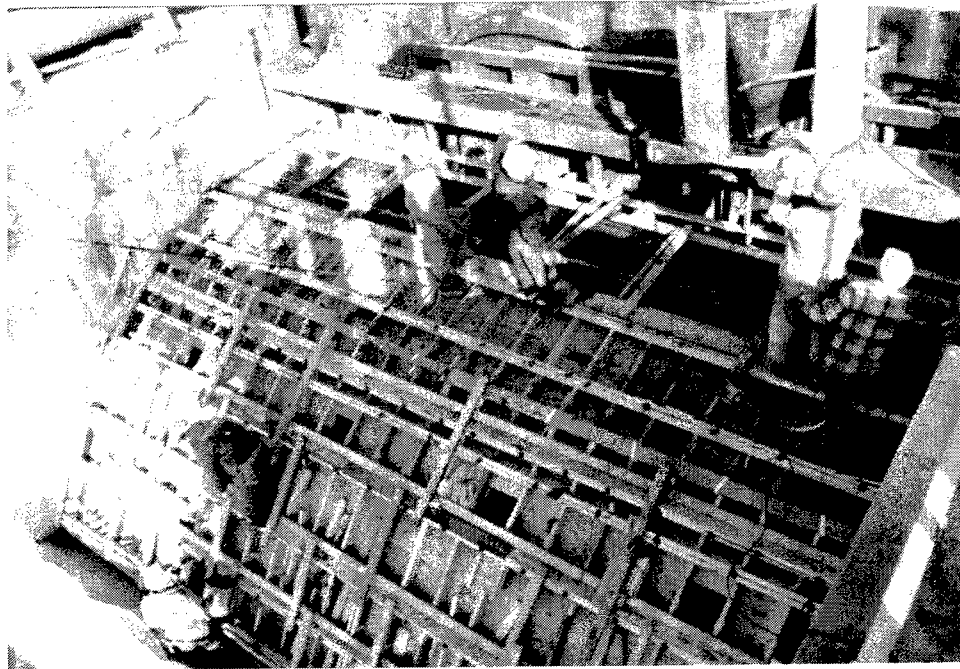

Figure 22. Concrete placed in the ice chute during conversion to ogee crest, Dresden Island Lock and Dam

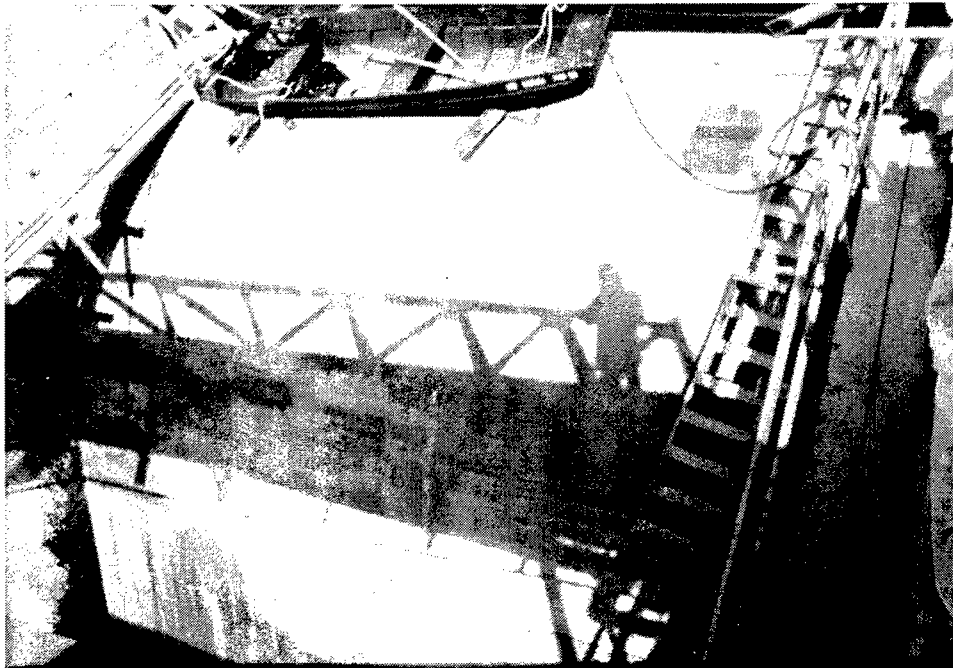

Figure 23. Completed ice chute, Dresden Island Lock and Dam

Estimated quantities and 1980 bid prices for the work were as follows: tainter gate piers, \$1,486,820; conversion of ice chute to overflow, \$117,710; head gate piers, \$279,258; arch dam abutments, \$348,555; boiler house pier, \$98,227.

The fifth periodic inspection (USAED, Rock Island 1990) noted only minor cracking in the rehabilitated structure. The inspection team for the sixth periodic inspection (USAED, Rock Island 1995) reported efflorescence on the bottom construction joint of the head gate bulkheads, but there was no indication of seepage. The arch dam also had efflorescence at some cracks and joints but, otherwise, was in good condition.

### **LaGrange Lock and Dam**

LaGrange Lock and Dam is located on the Illinois Waterway about 13 km (8 miles) downstream from Beardstown, IL. The lock is 33.5 m (110 ft) wide by 183 m (600 ft) long with a normal lift of 3.1 m (10 ft). The dam is 165 m (540 ft) long. It is one of the few wooden wicket dams remaining in the United States.

The wicket dam allows towboats to bypass the lock in open pass navigation when flows are sufficient to lower all of the wickets. This condition occurs about 50 percent of the time during a year. There are, however, several problems with the wicket dam, the biggest being that ice and debris cannot pass through the dam while the wickets are raised, which they must be during low river flows. Even the flip top, hinged wickets, which can lower the top 0.9 m (3 ft), cannot sufficiently pass heavy ice flows. The dam had no other section for passing ice

or debris. Backed-up ice inhibits the movement of tows and slowed lockages; ice lockages are frequently required to remove large quantities of ice while tows wait for a clear lock. Other problems with the wickets are that, in the lowered position, they pass a column of water that causes severe scouring action. Also, raising or lowering the wickets as flows change is a slow process.

To alleviate some of the problems of the wicket dam and to provide ice passage capability and a safer means of regulating flow, a section of the wicket dam was replaced with an 25.6-m- (84-ft-) wide, submersible gate adjacent to the lock wall. Appurtenant piers, gate sills, an apron, and a service bridge were included in the modification plan.

The contractor constructed a single-wall, internally braced sheet-pile cofferdam to dewater the work site. Three sides of the cofferdam were constructed of sheetpiling driven to an impervious layer. The fourth side consisted of the lock wall and its cutoff and a supplemental cutoff driven parallel to the lock wall. Tremie concrete placed between the supplemental cutoff and the lock wall formed a seal. The contractor assembled the cofferdam bracing above the sheet piles and lowered the 526 Mg (580 tons) of framing into the sheet piling with four hydraulic jacks. Bolted connections were designed to allow relocation of columns, struts, and cross bracing to accommodate construction activities (Figure 24).

A concrete pier, 27.4 m (90 ft) long, 4.9 m (16 ft) wide, and 12.2 m (40 ft) high, a new gate sill, 35 m (115 ft) long, 26 m (85 ft) wide, and 3 m (10 ft) thick, and a half pier section were constructed to accommodate the submersible gate. Ready mix trucks were used to transport the concrete from a plant about 20 minutes from the dam. The trucks were loaded onto a barge; concrete was discharged into buckets and transferred by a crane to the forms (Figure 25). Lifts were restricted to 2.3 m (7-1/2 ft). Vibrators were used to consolidate the concrete, which was then moist-cured where possible; curing compound was used where necessary. A high-pressure water jet was used to clean lift joints. The last step was to place the gate between the new piers (Figure 26).

Estimated bid prices (1987) were as follows: stool reinforcement, \$65,250; concrete anchors, \$6,050; and concrete, \$2,081,208.

Some fine shrinkage cracks were noted during a periodic inspection conducted during August 1991.

### **Lock and Dam No. 20, Mississippi River**

Lock and Dam No. 20 is located upstream of Canton, MO. The 699-m- (2,294-ft-) long structure includes a 653-m (2,144-ft) section that contains 40 tainter gates and 3 roller gates and a 46-m (150-ft) nonoverflow section. Over time the structure experienced concrete deterioration, especially around the tainter gates and service bridge piers. Cause of the deterioration is attributed to the lack of entrained air in the concrete, which decreased its resistance to cycles of freezing and thawing, alkali-silica reactions, and ponding of water on the tops

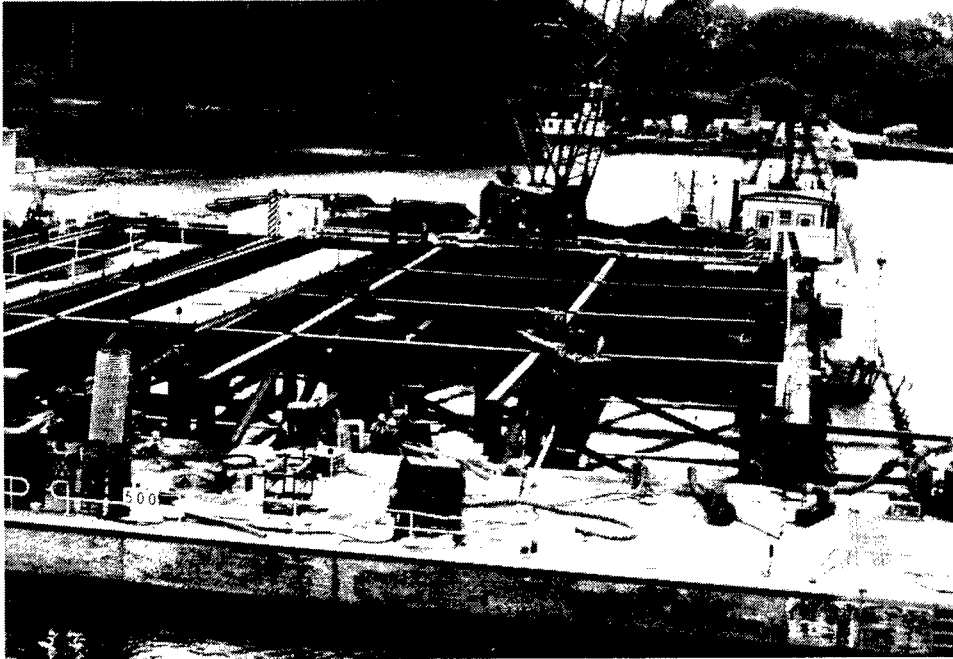

Figure 24. Braced steel sheet-pile cofferdam, LaGrange Lock and Dam

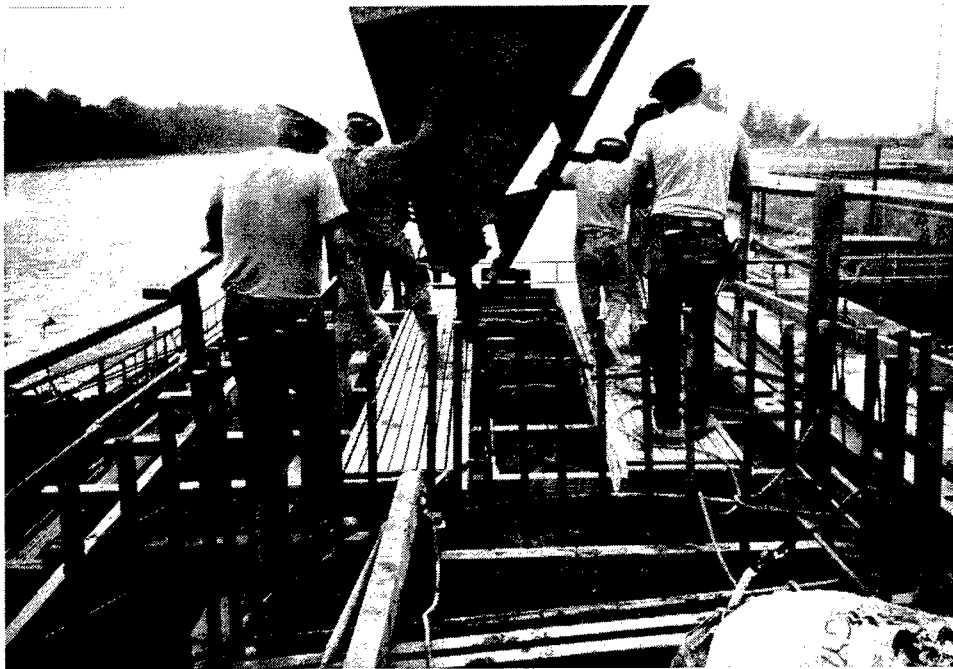

Figure 25. Concrete placement in riverward pier at LaGrange Lock and Dam

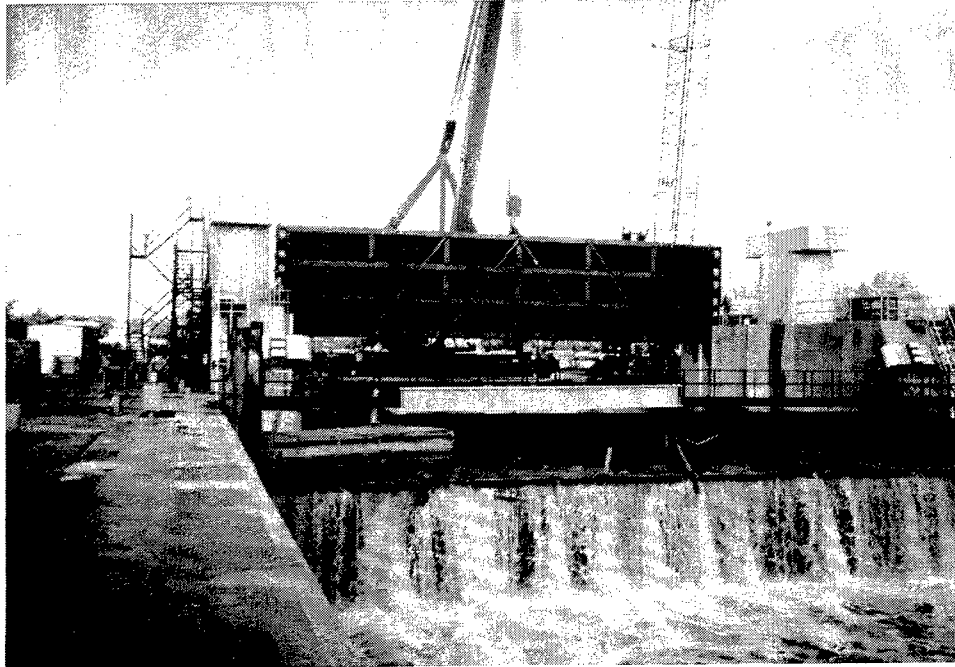

Figure 26. Placing of submersible gate, LaGrange Lock and Dam

of the piers, which contributed to the extreme cracking and leaching in these areas.

In August 1982, Pier 39 was selected as a test site for in situ repair of cracked concrete (Doak 1988). The repair method was to use high pressure to inject a low-viscosity epoxy grout into the crack. The worst areas of deterioration on the pier were so severe that intact cores could not be extracted, and the crack system was too extensive for individual crack repair to be considered. The contractor had 25-mm (1-in.) injection ports installed in a grid pattern. The pier faces were sandblasted to ensure that they were clean, and then water was injected to locate extensive interconnection. The pier was sealed with a trowel-on epoxy, and then low-viscosity epoxy was injected through the ports with pressures up to 1.1 MPa (160 psi). The injection procedure was downward from the top of the pier, upward in the archway, and horizontally on the downstream and east sides; the upstream and west sides were not injected. Approximately 30 l (8 gal) of epoxy was injected into the pier.

Ultrasonic velocity measurements were made before and after the injection, and, where practical, tests were run on core samples. One concern was that since the piers are integral with the submerged part of the dam, encapsulation could occur in the concrete behind the injected faces. If this encapsulation did occur, there would likely be rapid deterioration from cycles of freezing and thawing of the injected pier. Cores taken at intervals since 1982 and the Fifth Periodic Inspection (USAED, Rock Island 1991b) indicated no problem. The major problem was that the epoxy sealant used to waterproof the pier tops did not completely seal them, and seepage still occurred through unfilled cracks.

A further test of in situ repair was conducted on Pier 27 during August 1987 (Webster, Kukacka, and Elling 1989). For this test, an ultra-low-viscosity material was used, and injection was made through holes in wood dowels bonded directly to the concrete surface (Figure 27). This test demonstrated that pressure injection repair techniques can restore the integrity of cracked concrete hydraulic structures.

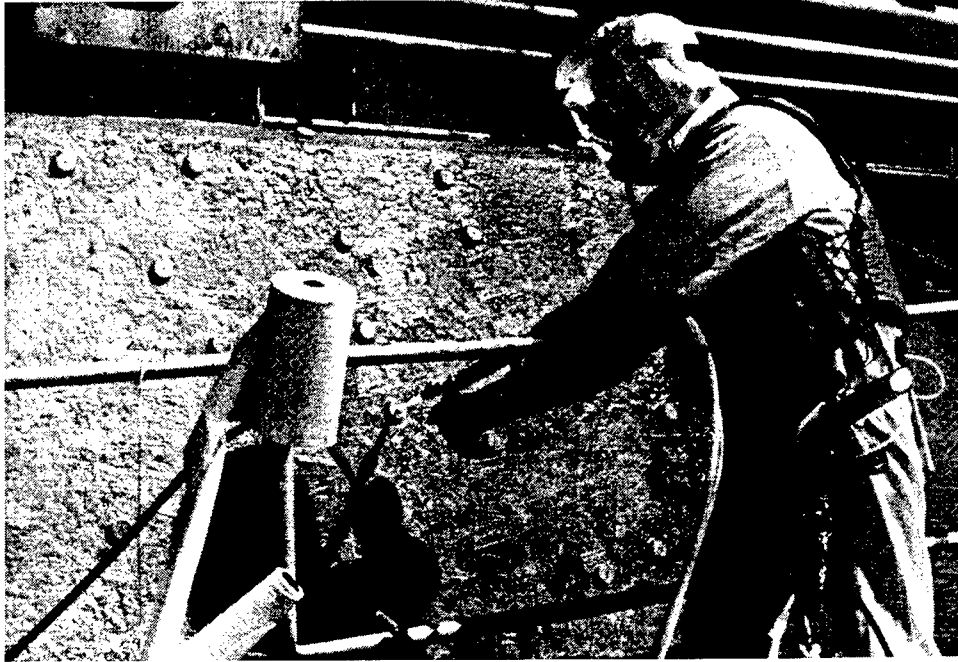

Figure 27. Epoxy injection of pier stem at Lock and Dam No. 20, Mississippi River

The Stage III contract was awarded in June 1988, with most of the work done during the 1989 construction season. The contract, based on a report of the epoxy injection of Pier 39 and draft copies of REMR reports done by the Brookhaven National Laboratory, called for the epoxy injection of 36 piers, the removal of the top 0.5 m (1.5 ft) of all the pier stems and replacement with conventional concrete with improved drainage features, and installation of new bridge bearings.

During the 1989 construction season, 13 pier stems were injected and cored. The first step in the epoxy injection procedure was to clean the surface of the pier with a power grinder. Port holes were then drilled and installed along the crack network. A water pressure test was performed, and the results indicated the need for additional ports. The surface was then sealed with an epoxy gel. The epoxy injected into the pier was an ultra-low viscosity, two-component, 100 percent solids epoxy resin, insensitive to the presence of water. Injection started at the lowest point of the area on the pier and moved up. Injection pressures were limited in the specifications to a maximum of 1.1 MPa (160 psi).

Techniques used to monitor the adequacy of the epoxy injection work included pre- and postinjection pulse velocities, visual examinations of cores, and petrographic analysis, which included examination of the length of injected and noninjected cracks and the maximum depth of epoxy injected. Pulse velocities, splitting tensile strengths, and unconfined compressive strengths were determined on various portions of the cores.

Results revealed very little differences between the preinjection and post-injection pulse velocities taken on the piers. Velocities that were low remained low; those that were high remained high.

One hundred and two-millimetre- (102-mm-) (4-in.-) diam cores, approximately 0.5 m (1.5 ft) long were examined. The total length of fractures along the outside surface ranged from 2,858 to 8,453 mm (112.5 to 332.79 lin in.) in the upper zone to 2,883 to 5,338 mm (113.51 to 210.16 lin in.) in the lower zone.

The petrographic examinations revealed that an average of 69 percent of the cracks in the upper zones of the cores were filled with epoxy. Piers that exhibited less cracking had a greater percentage of fractures filled than those that exhibited more cracking. Pier 42 was injected through 1,052 ports (approximately one port for every 0.07 sq m (0.75 sq ft)) of pier surface to be injected. Cores from this pier, which had more cracking, averaged 89 percent of the fractures in the upper zone filled. An average of 31 percent of the cores in the lower zone were filled.

The epoxy-injected upper cores had an average compressive strength of 25.7 MPa (3,727 psi) (the average compressive strength of cores taken in "sound" concrete, with no epoxy, was 42.8 MPa (6,212 psi), an average splitting tensile strength of 3.4 MPa (494 psi), and an average pulse velocity of 2,229 mps (7,313 fps). The concrete in Pier 42 fell in the range of poor-quality concrete, (2,133 to 3,048 mps (7,000 to 10,000 fps)).

The epoxy showed variable bonding strength, ranging from well-bonded in thick sections to poorly bonded where the epoxy was thin.

After analysis of the data and evaluation of epoxy injection program, USAED, Rock Island, decided to abandon the epoxy injection method and to modify the contract to remove and replace the remaining badly cracked and deteriorated pier stems. Seven pier stems were removed and replaced. Since all work had already been accomplished on the other piers and the contractor had already replaced the service bridge, no additional work was required for these piers.

Periodic inspection of the piers will help the Rock Island District determine what percent of voids filled is required to prevent further damage to the concrete from cycles of freezing and thawing. The addition of the new 0.5 m (1.5 ft) of air-entrained concrete along with new bridge bearings will add considerable longevity to the injected piers since it eliminated a major source of free water.



The Sixth Periodic Inspection Report (USAED, Rock Island 1996) described the condition of the concrete in the dam good. The report also stated that the one concrete pier tested by epoxy injection during the last major rehabilitation was in satisfactory condition and the concrete surrounding the epoxy-treated area was in sound condition.

## **Marseilles Dam**

Marseilles Dam, located 105 km (65 miles) southwest of Chicago on the Illinois River, was constructed in 1933 to control river flow and to maintain a 2.7-m (9-ft) navigation channel. In addition to the main dam, the project has two auxiliary dams and a lock, which is located 4 km (2-1/2 miles) downstream. The original main dam consisted of a 168-m- (552-ft-) wide section that had eight tainter gates. A 1983 inspection of the project revealed that the tainter gates and the service bridge had severe corrosion damage, and the concrete in the top third of the piers had both pattern and D-cracking, as well as surface leaching. Also, the bullnoses of the piers had suffered damage from impact. The spillways showed signs of mild abrasion but were generally sound. Monolith joints on the canal guide wall were deteriorated and in need of repair.

Damage to the tainter gates was attributed to ice loads, abrasion, and impact; concrete deterioration in the piers was a result of cycles of freezing and thawing; thermal expansion and cycles of freezing and thawing were cited as the causes of deterioration of the monolith joints. Restoration plans included replacing the tainter gates with submersible gates and the service bridge, removing and replacing deteriorated concrete on the piers, and reconstructing the monolith joints.

The decision to replace the nonsubmersible tainter gates was based upon past performance of the gates during winter conditions and results of a structural analysis of the gates performed with updated criteria. The original gates were not designed for ice loads nor for passing ice and debris. During the worst winter weather, the gates could not be raised because of the weight of the ice. Workers would then have to use steam and ice-chipping tools to restore gate operation, a dangerous and time-consuming exercise. The structural analysis showed that the original design load was no longer sufficient; according to current criteria, some of the gates were overstressed and others were borderline. A plan to reconstruct the existing gates showed this option was not cost-effective. The final decision was to replace the gates with submersible tainter gates.

The Rock Island District had already used submersible tainter gates at several dams. The design of the new gates for Marseilles Dam was based on the design used on similar dams in the district. The design ice load for the gates is 0.24 MPa (5,000 lb/sq ft) at the waterline, in combination with the water load, mud load, dead weight, cable tension, and the trunnion reaction. The new gates are supported on top and bottom with plate girders that extend the width of the gate; on the sides these girders are attached to top and bottom strut arms, which

transfer external loads to the trunnion. Each gate is further stiffened with upstream and downstream skin plates strengthened with three interior and two end diaphragms. With the exception of certain corrosion-resistant elements, the skin plate and balance are made of American Society of Testing and Materials (ASTM) A36 steel (ASTM 1995a). Each 64-Mg (71-ton) gate was prefabricated and delivered to the job site.

The new gate system was designed to be operationally efficient and to eliminate the short-coming of the old counter-weighted tainter gate system. Before the submersible gates were installed, a model study was performed at WES to evaluate their hydraulic and stilling basin performance.

To replace the gates and complete repair work, it was necessary for the contractor to dewater each spillway sequentially. The contractor was faced with the challenge of constructing a reusable cofferdam that could withstand 6.1 m (20 ft) of water. Bedrock just below the bottom of the reservoir ruled out use of conventional sheetpiling. The solution was a local cofferdam that could be flooded to provide stability (Figure 28) (Stone and Webster).

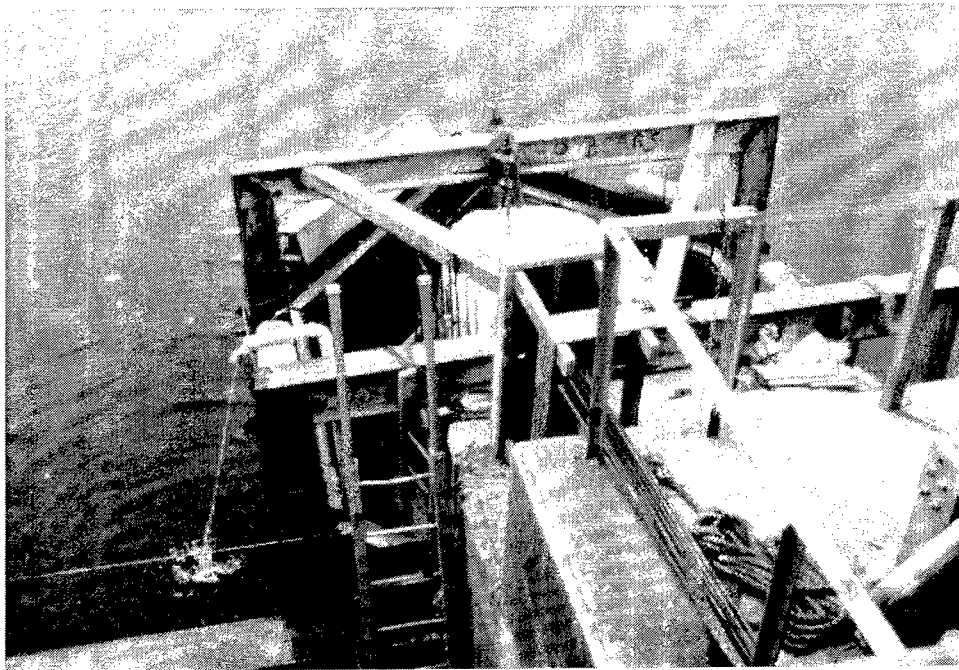

Figure 28. Local cofferdam used to dewater bullnose piers, Marseilles Dam

Before the new submersible tainter gates could be installed, the piers had to be repaired and modified and the gate sills reconstructed. The ogee crest was removed and some concrete was removed from the side of the pier to accommodate the new gate (Figure 29). Concrete repair consisted of removing the deteriorated nonair-entrained concrete and replacing it with conventional reinforced mass concrete. In addition to visual inspection, concrete in the piers was further evaluated by coring. Concrete cores revealed that deterioration ranged



Figure 29. Concrete removal of ogee crest and side of pier to accommodate new gate, Marseilles Dam

from 102 to 254 mm (4 to 10 in.) deep and that the compressive strength of sound concrete was from 55 to 69 MPa (8,000 to 10,000 psi). Damaged concrete was removed to sound concrete, approximately 229 mm (9 in.). Deteriorated concrete was line drilled (Figure 30) and then removed with jackhammers and expansive grout. Diamond wire cutting was used to remove end blocks of concrete from the piers to allow for the installation of the new trunnion supports (Figure 31). With a cutting speed of 0.9 to 3.7 sq m/hr (10 to 40 sq ft/hr), the diamond wire was faster than conventional methods, and it required fewer workers. The pier sections were cut free in two work shifts.

All horizontal surfaces were sloped slightly to prevent water ponding. A 0.5-m- (14-ft-) high extension was added to each pier so the gates could be raised to maximum elevation. Sills for the tainter gates were altered from an ogee shape to one that would allow the gates to be submerged (Figure 32). Post-tensioned tendons on the pier sides were used to support the trunnion anchor beam and resist trunnion loads. The tendon load was transferred into the parent

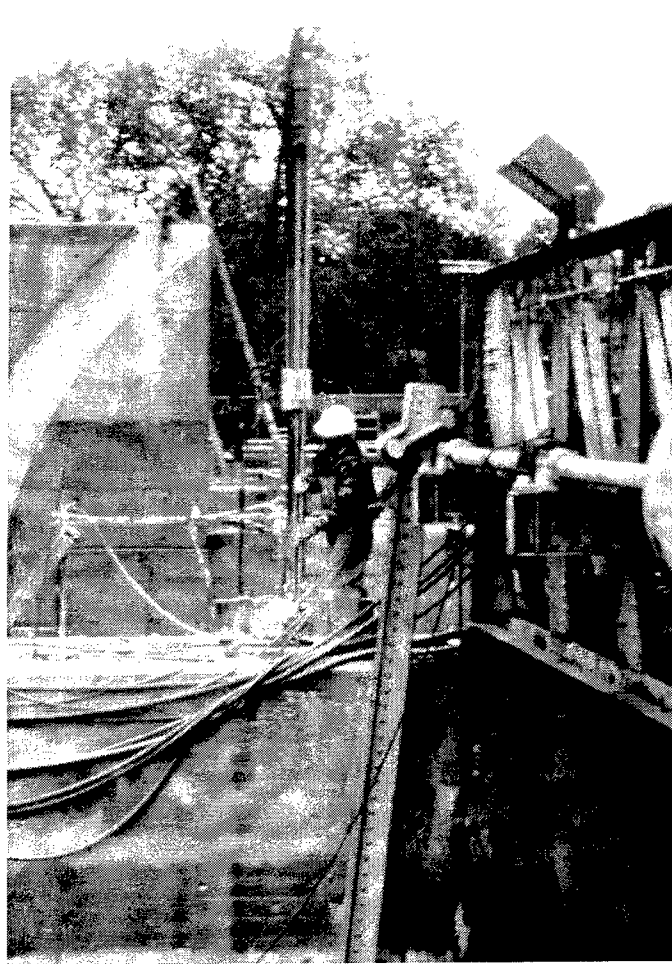

Figure 30. Line drilling for concrete removal at Marseilles Dam

concrete with shear reinforcement. Cables were protected from direct impact by the construction of an ice and debris deflector. Guide wall joints were reconstructed with new expansion joint material.

In addition, the service bridge was replaced with a new steel bridge, and the ice chute gate was replaced with an ogee spillway. To reduce staffing requirements, a new system for operating the dam gates was being installed under an ongoing contract. The new system would allow the gates to be operated manually at the dam, by remote control from the lock, and automatically in response to fluctuations in the pool. To ensure the safety and future integrity of the structure, a surveillance and public announcement system was also to be installed (Wehrley 1988).

Construction was set to begin in September 1985 and to be completed in September 1988. Cost for the project was approximately \$15 million (1985-1988 dollars).

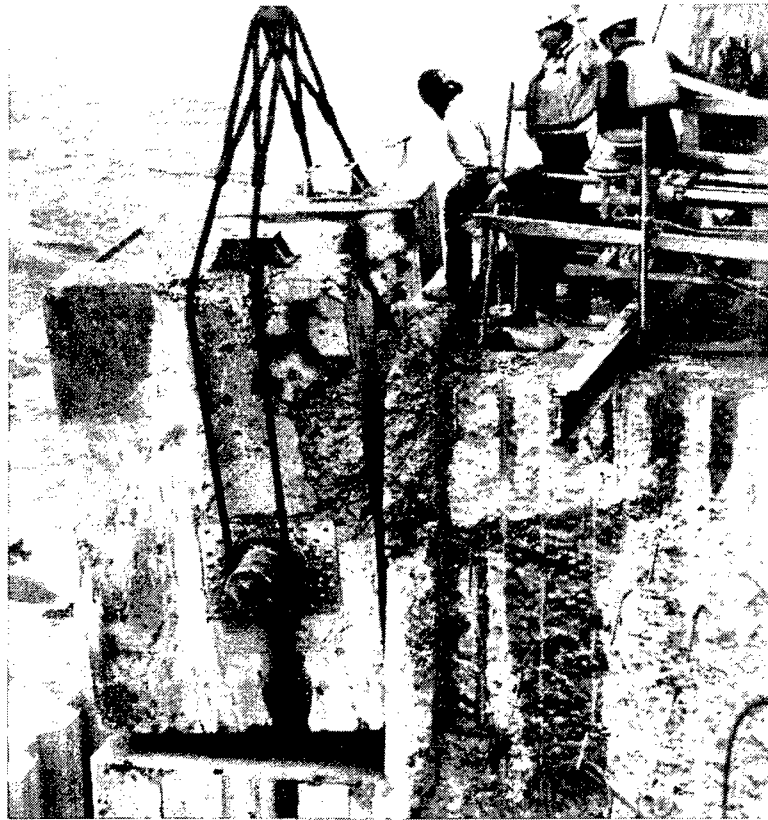

Figure 31. Twenty-nine thousand thirty and four-tenths-kilogram (32-ton) section cut from pier with diamond wire cutter, Marseilles Dam (from Cutting Technologies, Inc. 1990)

### Peoria Lock and Dam

Peoria Lock and Dam is located on the Illinois Waterway, just downstream from Peoria, IL. The lock is 33.5 m (110 ft) wide, 183 m (600 ft) long, and has a lift of 3 m (10 ft). The dam is 165 m (540 ft) long. It is one of the few wooden wicket dams remaining in the United States (Figure 33).

The wicket dam allows towboats to bypass the lock in open-pass navigation when flows are sufficient to lower all of the wickets. This condition occurs about 40 percent of the time during a year. There are, however, several problems with wicket dams, the biggest being that ice and debris cannot pass through the dam while the wickets are raised, which they must be during low river flows. Even the flip-top, hinged wickets, which can lower the top 0.9 m (3 ft), cannot sufficiently pass heavy ice flows. The dam had no other section for passing ice or debris. Backed up ice inhibits the movement of tows and slow lockages; ice lockages are frequently required to remove large quantities of ice while tows wait for a clear lock. Other problems with the wickets are that, in the lowered position, they pass a column of water that causes severe scouring action. Also, raising or lowering the wickets as flows change is a slow process.

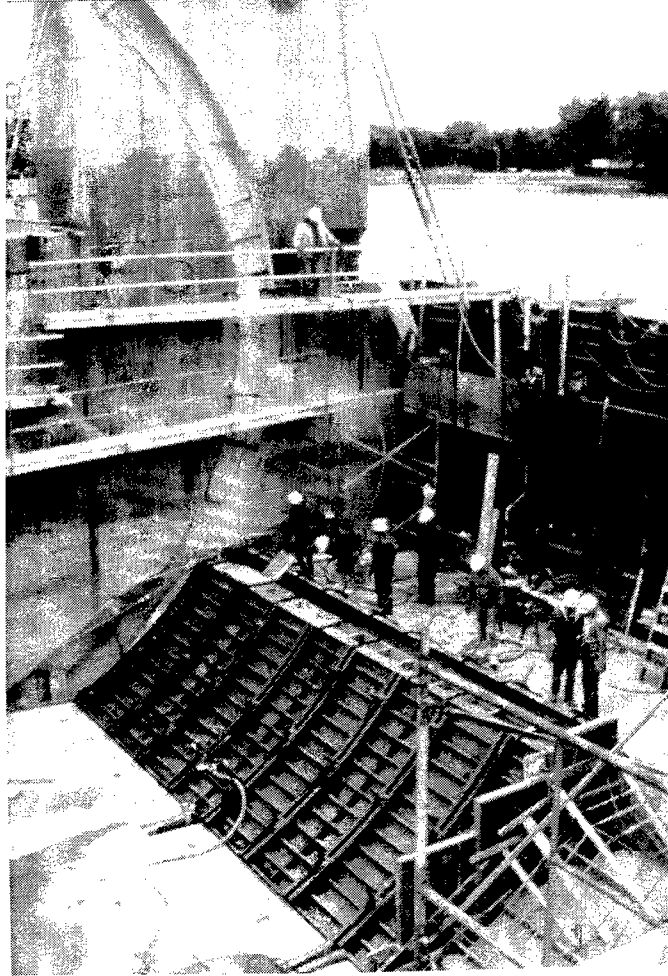

Figure 32. Concrete placement in new gate sill, Marseilles Dam

To alleviate some of the problems of the wicket dam and to provide ice passage capability and a safer means of regulating flow, a section of the wicket dam was replaced with a 25.6 m (84-ft) wide, submersible gate adjacent to the lock wall. Appurtenant piers, gate sills, an apron, and a service bridge were included in the modification plan.

The contractor constructed a single-wall, internally braced sheet-pile cofferdam to dewater the work site. Three sides of the cofferdam were sheet-piling driven to an impervious layer. The fourth side consisted of the lock wall and its cutoff and a supplemental cutoff driven parallel to the lock wall. Tremie concrete placed between the supplemental cutoff and the lock wall formed a seal. The contractor assembled the cofferdam bracing above the sheet piling and lowered the 526 Mg (580 tons) of framing into the sheetpiling with four hydraulic jacks. Bolted connections were designed to allow relocation of columns, struts, and cross bracing to accommodate construction activities.

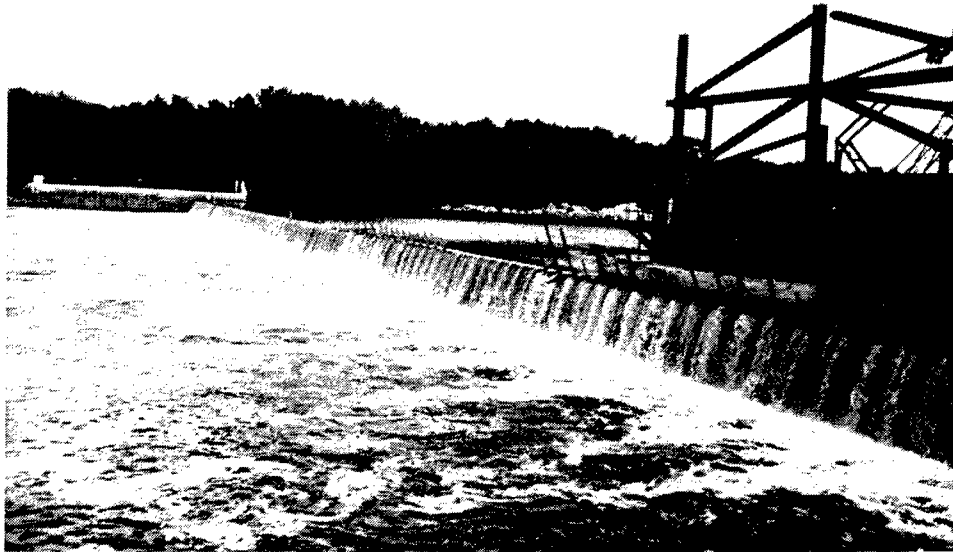

Figure 33. Peoria Dam before a section of the wicket dam was replaced with a submersible gate

After the cofferdam was pumped down, a seepage problem developed. The pressure of the water from the upper pool caused the supplemental cutoff piling to separate from the tremie concrete seal. A concrete cap was placed over the supplemental sheet-pile cutoff and anchored to the lock and additional piling was connected to the cofferdam and capped with concrete to lengthen the seepage path. Voids that had developed under the lock wall were filled with sand and chemical grout.

A concrete pier, 27.4 m (90 ft) long, 4.9 m (16 ft) wide, and 12.2 m (40 ft) high, a new gate sill, 35 m (115 ft) long, 26 m (85 ft) wide, and 3 m (10 ft) thick, and a half pier section were constructed to accommodate the submersible gate. The approximate mixture proportions for the concrete were 267 kg per cu m (450 lb per cu yd) Type I cement, 71 kg per cu m (120 lb per cu yd) Class C fly ash, 119 kg per cu m (200 lb per cu yd) coarse aggregate, 591 kg per cu m (995 lb per cu yd) fine aggregate, 0.66 l per cu m (17.1 oz per cu yd) Type A water reducer, and 0.12 l per cu m (3 oz per cu yd) air-entraining admixture.

Ready-mix trucks were used to transport the concrete from a plant about 20 minutes from the dam. The trucks were loaded onto a barge; concrete was discharged into buckets and transferred by a crane to the forms. Lifts were restricted to 2.3 m (7-1/2 ft). Vibrators were used to consolidate the concrete, which was then moist-cured where possible; curing compound was used where necessary. A high-pressure water jet was used to clean lift joints. The completed piers and gate are shown in Figure 34.

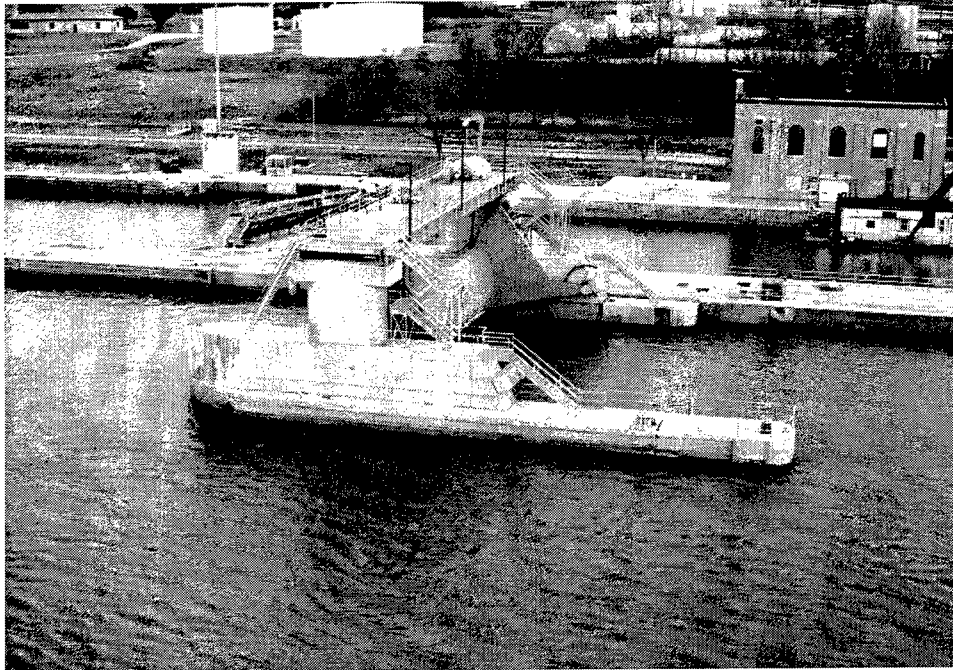

Figure 34. Completed piers and gate constructed at Peoria Dam

Estimated bid prices (1987) for the rehabilitation were steel reinforcement, \$217,500; concrete anchors, \$6,655; and concrete \$1,971,952.

The report of the Fifth Periodic Inspection (USAED, Rock Island 1991c) noted a fine longitudinal crack in the riverward pier; otherwise, concrete in the dam was reported to be in excellent condition.

### **Red Rock Dam**

Red Rock Dam is located on the Des Moines River near Pella, IA. The dam was opened for operation in 1969. The 1,890-m- (6,200-ft-) long, 29-m- (95-ft-) high dam is composed of two rolled earth-fill embankments separated by a concrete section that contains a spillway with an ogee crest and an outlet works. The spillway has five tainter gates, each 12.5-m (41 ft) wide by 15-m (49 ft) high. The outlet works consists of fourteen 1.5- by 2.7-m (5- by 9-ft) conduits that pass through the ogee section. The 73- by 65-m (240- by 214-ft) stilling basin passes a minimum flow of 8.5 cms (300 cfs), even in dry seasons.

A diver inspected the stilling basin in 1982 and found several small areas where concrete and bedrock had been eroded along the end sill. Heavy rains in 1983 and 1984 resulted in discharges ranging to 1,133 cms (40,000 cfs) as compared to normal discharges of 85 cms (3,000 cfs). As a result of the inspection and the subsequent high discharges, plans to repair the dam were begun.



A major concern was the high cost of dewatering the dam for the repair, especially since the damage to the stilling basin was not considered to be severe. A report of laboratory tests (Neeley and Wickersham 1989) indicated that cohesive, flowable, abrasion-resistant concrete that would bond well to in-place hardened concrete could be placed underwater without use of a tremie seal if proper materials and placement procedures were used. The addition of antiwash-out and water-reducing admixtures to the concrete mixture and tremieing the concrete at the point of use allowed for placement with minimum loss of fines. Underwater repair was selected as being the most cost-effective alternative.

A final underwater inspection of the stilling basin was performed in August 1988, just before repair work was begun. The eroded areas, mostly in the bedrock, extended about 5.5 m (18 ft) downstream of the end sill; maximum depth of the eroded areas was approximately 1.5 m (5 ft). Prior to concrete placement, loose rock and debris were removed, and anchors and reinforcing were installed.

Holes for the anchors were air-percussion drilled 3 m (10 ft) deep. Spacers were used to maintain an annular space to be filled with cementitious nonshrink grout. A 102- by 102-mm (4- by 4-in.) steel plate was placed over each anchor to minimize the washing away of the grout. A wall of grout-filled bags with a vertical upstream face and a sloping downstream face was constructed 1.5 m (5 ft) downstream from the end of the sill to help contain the concrete during placement (Figure 35).

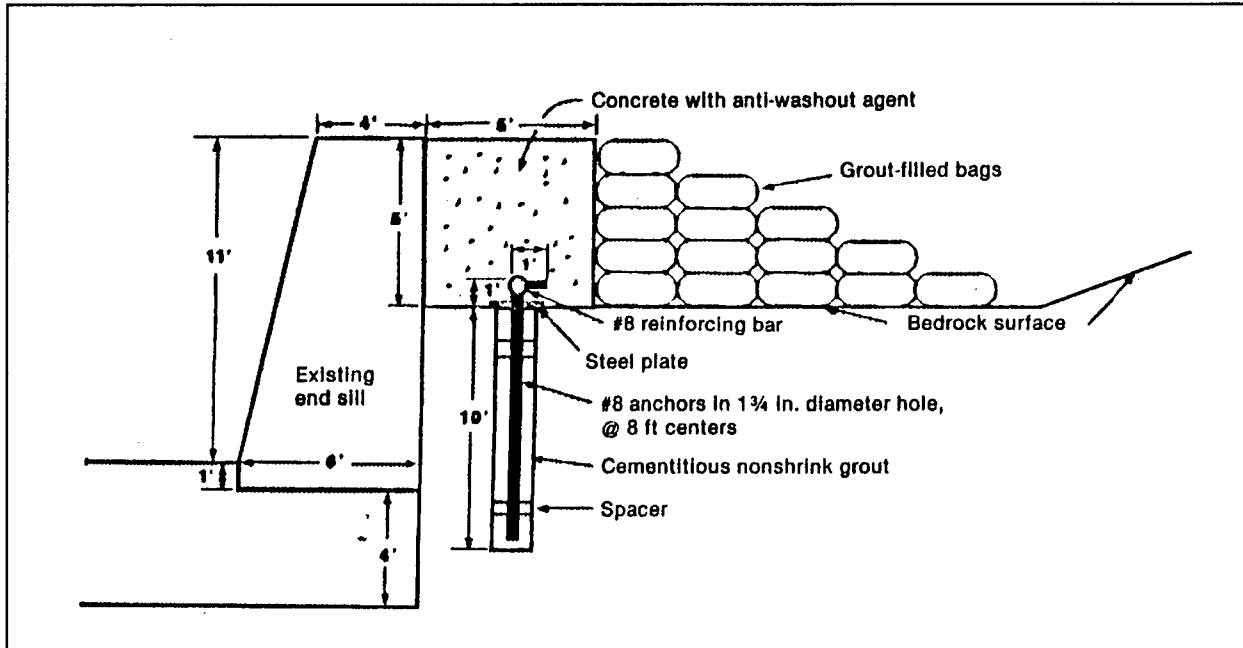

Figure 35. Anchor and concrete placement at the end sill, Red Rock Dam (from Neeley and Wickersham 1980)

Concrete mixture proportions for 1-cu m (1-cu yd) batch were 415 kg (700 lb) of Type 1 Portland cement, 729 kg (1,229 lb) of fine aggregate, 946 kg (1,594 lb) of coarse aggregate, 163 kg (275 lb) water, 0.19 ℓ (5 fl oz) of antiwashout admixture, 1.63 ℓ (42 fl oz) of water reducing admixture, and 0.80 ℓ (2 fl oz) of air-entraining admixture. The concrete was delivered to the job site by truck mixers, each arriving about 2 min after the previous truck had finished unloading. Haul time was approximately 15 min. A 102-mm- (4-in.-) diam pump line controlled by a diver was used to place the concrete approximately 7.6 m (25 ft) underwater (Figure 36). Placement began at the middle of the end sill and worked toward the north bank. During placement, water was discharged through the dam at a minimum 8.5 cms (300 cfs), and the river water temperature was about 26 °C (80 °F). The end of the pump line was kept embedded in the mass of concrete being discharged; the diver moved the line around to completely fill the repair area. Approximately 31 cu m (40 cu yd) of concrete was placed in the northern half of the end sill in about 1-1/2 hr.

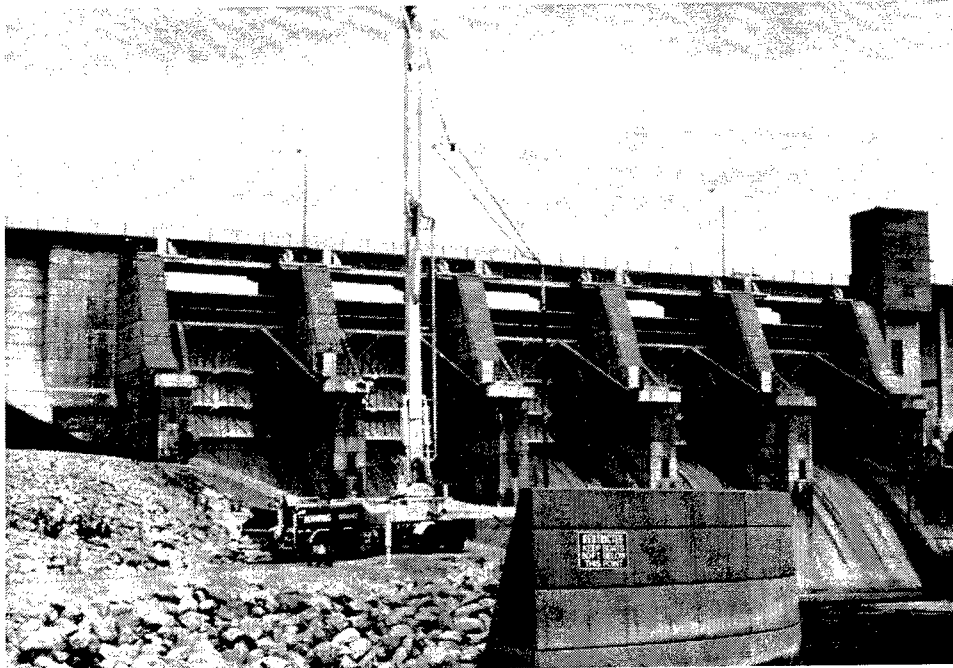

Figure 36. Concrete pump used for end sill repair at Red Rock Dam

Placement on the southern shore of the river was not quite as smooth. The truck mixers generally waited 15 to 20 min at the site before unloading. However, the delay did not appear to affect the workability of the concrete. Approximately 46 cu m (60 cu yd) of concrete was placed in the southern half of the end sill in about 2-1/2 hr.

The diver inspected the entire placement before coming to the surface. He reported that the area between the bag wall and the end sill was completely filled and that the concrete placed earlier in the day was beginning to harden. Although the concrete mixture had a slump of about 229 mm (9 in.), the diver

reported that it was very cohesive, pumped well, and self-levelled within a few minutes of placement.

Approximately 76 cu m (100 cu yd) of concrete was placed in 4 hr. Total cost of the repair was \$128,000, a considerable savings since estimates for dewatering alone ranged from \$500,00 to \$750,000 (Neeley and Wickersham 1989).

### **Starved Rock Lock and Dam**

Starved Rock Lock and Dam is located on the Illinois Waterway in Utica, IL. The project was completed in 1933. The lock is 33.5 m (110 ft) wide and 183 m (600 ft) long and has a lift of 5.7 m (18.7 ft). The dam consists of a 173-m (566-ft) head gate section, a 9.1-m (30-ft) ice chute, and a 208 m (684-ft) tainter gate section.

After almost 50 years of exposure to cycles of freezing and thawing and impact and abrasion from ice and debris, the nonair-entrained concrete in the structure showed signs of deterioration. An evaluation of the dam indicated that the rehabilitation should include construction of closure panels for the head gate section, conversion of the gated ice chute to an uncontrolled ogee crest, and resurfacing of the tainter gate piers.

The closure panels for the head gate section were 4.3 m (14 ft) wide, 4.9 m (16 ft) high, and 0.8 m (2 ft 6 in.) thick. Two rows of No. 6 steel bars on 229-mm (9-in.) centers were installed to anchor the panels (Figure 37). Deteriorated concrete was removed from the roof of the head gate opening, and a waterstop was installed along the perimeter of the opening. The concrete for the closure panel was pumped to just below the opening (Figure 38), and then the opening was filled with nonshrink grout. Vibrators were used to consolidate the concrete. A curing compound was used for curing.

Rehabilitation of the tainter gate section consisted of removing and replacing concrete on the surface of the piers, installing new gate seal plates and heating elements along the sides of the piers, and modifying concrete to accommodate new bridge bearing details.

Concrete was removed to a depth of 152 mm (6 in.) for vertical and horizontal resurfacing. The replacement concrete was anchored to the piers with No. 6B steel bars on 0.6-m (2-ft) centers. Reinforcing consisted of welded wire fabric. A steel angle was embedded at the upstream bullnose of the piers. The contractor was concerned about being able to place the required 19-mm (3/4-in.) maximum concrete in the relatively narrow 152-mm (6-in.) section, which was congested with anchors, reinforcing, and other embedded items, so he requested permission to use a high range water reducer admixture (HRWRA) to increase workability of the concrete.

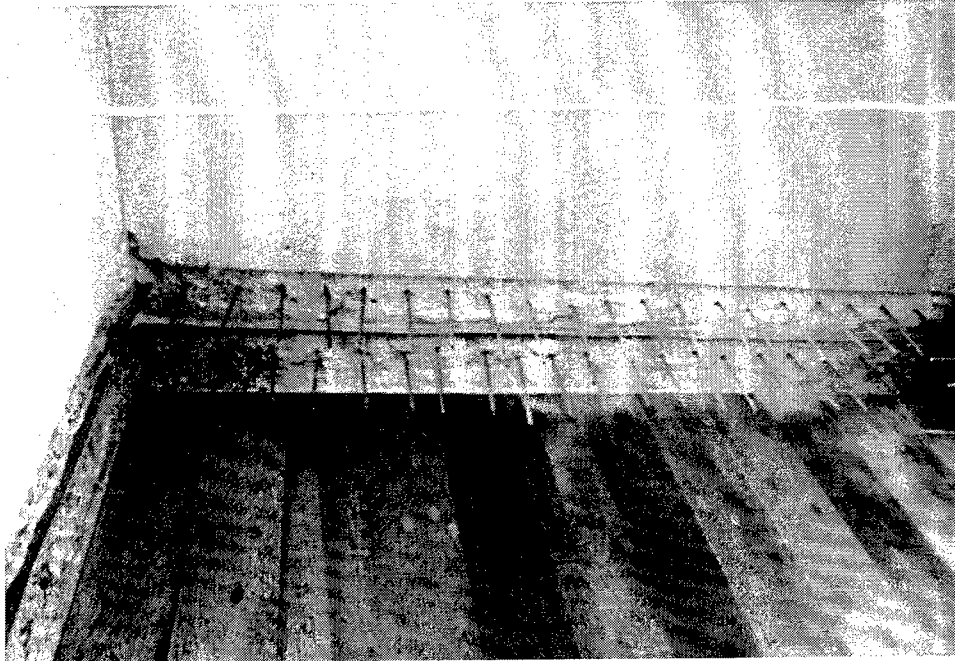

Figure 37. Anchors and waterstop installed in head gate section, Starved Rock Lock and Dam

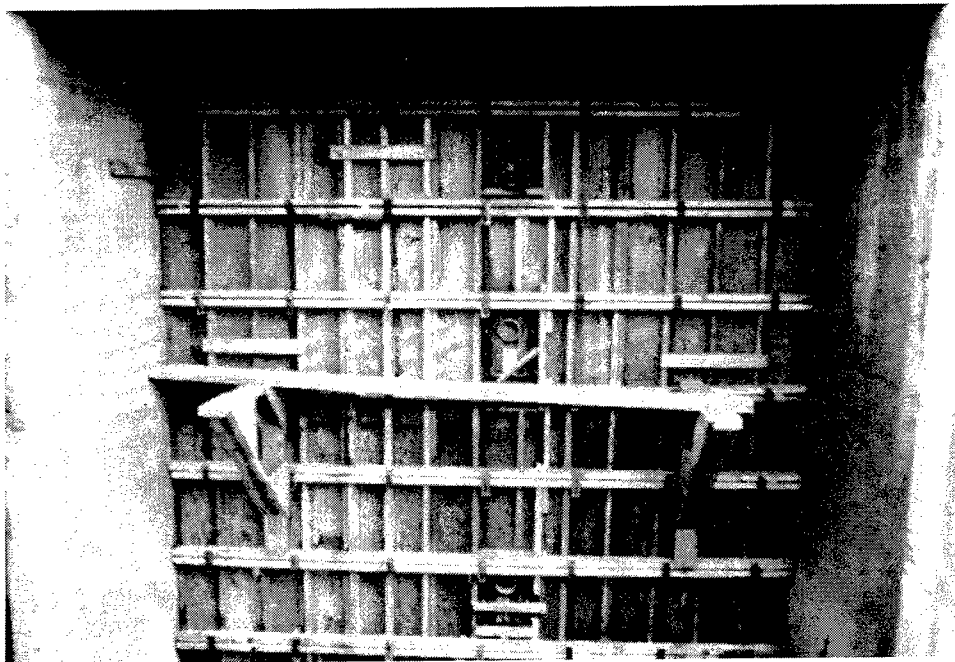

Figure 38. Forms and openings for pumping concrete for closure panels in head gate section, Starved Rock Lock and Dam

HRWRAs have altered the entrained air void system in concrete such that the concrete becomes nondurable; therefore, compressive strength tests and freeze/thaw durability tests were performed on the proposed concrete mixture with and without the HRWRA. Use of the HRWRA was approved. Approximate proportions for a 1-cu m (1-cu yd) batch of the concrete were 335 kg (564 lb) of Type I cement, 751 kg (1,265 lb) fine aggregate, 1,053 kg (1,775 lb) coarse aggregate, 158 kg (266 lb) water, 0.12 l (3 oz) air-entraining admixture, 0.66 l (17 oz) retarder, and 2.63 l (68 oz) HRWRA.

Ready-mix trucks carrying the concrete were transported by barge to the tainter gate section. A crane and bucket were used to place the concrete. A curing compound was used for curing the concrete. The rehabilitated tainter gate is shown in Figure 39.

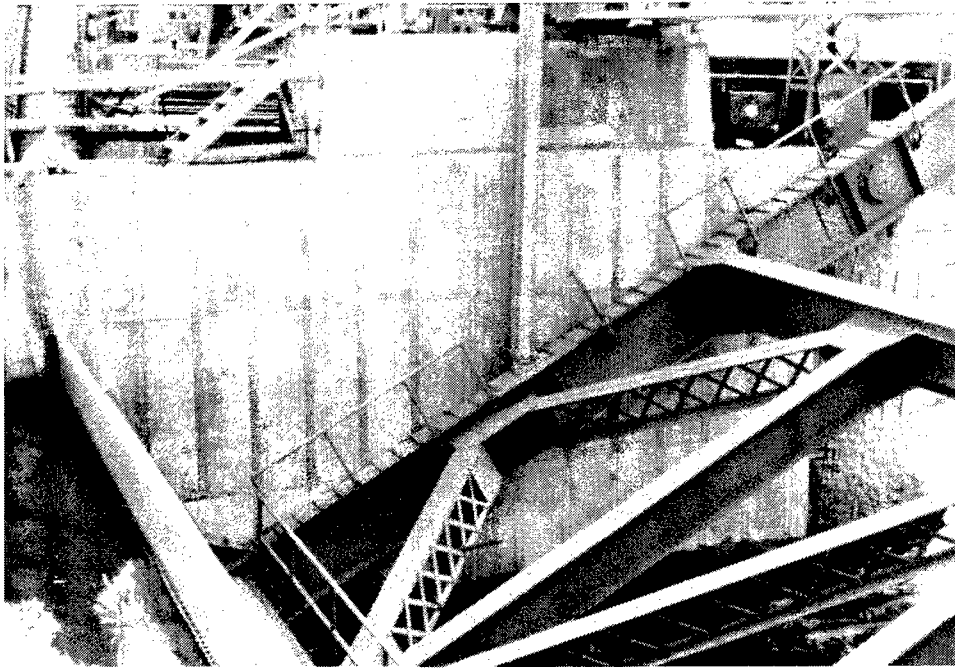

Figure 39. Tainter gate pier after rehabilitation, Starved Rock Dam

The wide gated ice chute was converted to an uncontrolled ogee crest. Some concrete had to be removed to obtain the ogee configuration. The downstream face was resurfaced and the gate recess in the sill was filled with concrete. The same type of anchoring and reinforcement as used on the tainter gate were used in rehabilitation of the ice chute. The converted ice chute is shown in Figure 40.

Estimated bid prices (1981) for the rehabilitation were as follows: tainter gate piers, \$1,396,470; ice chute conversion, \$59,480; and modification to the head gate bays, \$366,000.



Figure 40. Ice chute after being converted to ogee crest, Starved Rock Dam

## St. Paul District

### Lock and Dam No. 1, Mississippi River

Lock and Dam No. 1 is located on the Mississippi River at Minneapolis-St. Paul. The structure is part of a hydroelectric project. The 175-m (574-ft) Ambursen dam, which extends across the river from the lock river wall to the river wall of the hydroelectric power plant, was completed in 1917. Over time, concrete in the dam deteriorated as a result of weather conditions and use. An inspection in the early 1980s revealed deteriorated concrete on the apron downstream from the ogee crest, at the outlet end of the sluiceways, and in the monolith joints. Also, waterstops showed signs of wear. Dam repairs began November 1981.

The repair method was to remove the deteriorated concrete and replace it with conventional reinforced concrete. Deteriorated concrete on the apron and in the sluiceways was removed to a minimum depth of 305 mm (12 in.). In the sluiceways, the edges of the damaged areas were saw cut. Hooked reinforcing bars were drilled and grouted into the repair areas, and then the conventional reinforced concrete was placed. Before the repair concrete was placed in the sluiceways, an epoxy bonding agent was spread over the surface. Deteriorated monolith joints were routed and then reconstructed with preformed compression seals.

Repairs were completed in March 1982. A follow-up inspection determined that the concrete repairs were performing satisfactorily, but the expansion-joint material needed replacing.

Cost for the project, including demolition of deteriorated concrete, was approximately \$796,500.

The Third Periodic Inspection Report (USAED, Rock Island 1991) included the results of the concrete condition survey conducted on the Ambursen dam between 9-21 June 1990. The firm that performed the detailed inspection of the dam concluded there were no conditions that constituted an immediate threat to the stability or integrity of the dam. However, because the dam was aging, the inspection team recommended that the dam be closely monitored and that any conditions that could be detrimental to the integrity of the dam be corrected or repaired.

### **Lock and Dam No. 2, Mississippi River**

Lock and Dam No. 2 is located on the Mississippi River at Hastings, MI. Completed in 1930, the original dam was approximately 250 m (820 ft) long and included twenty 10.7-m- (35-ft-) wide tainter gates, twenty-one 1.5-m- (5-ft-) thick piers, and a 30.5- (100-ft) Boule dam. Later the 100-ft Boule dam was replaced with a concrete ogee spillway, which, in turn, was replaced with a hydroelectric plant. One of the tainter gate bays was closed, and the space was used for storage.

By 1988 the structure was in need of repair and rehabilitation. Concrete on the piers directly beneath the existing bridge had deteriorated, and there was surface spalling of the concrete on the faces of the piers and in the trunnion recesses. A contract for the repair work was let in September 1988.

Repair of the piers and trunnion recesses consisted of removing the deteriorated concrete and replacing it with fiber-reinforced, acrylic-polymer modified concrete (FRAPMC) and eliminating leakage into the trunnion recesses.

FRAPMC consists of mortar, coarse aggregate, and reinforcement fibers. It is mixed in a mortar mixer as a two-component system consisting of a liquid polymer emulsion of acrylic polymer and additives and a mixture of cements, aggregates, and admixtures. Polypropylene fibers and aggregate are mixed with the polymer emulsion mixture until the fibers are conditioned and dispersed, and then the cement mixture is added. Typically, FRAPMC is mixed in batches that can be placed within 30 min or less.

Specifications for this project called for FRAPMC with a compressive strength of 17.2 MPa (2,500 psi) at 3 days and 30 MPa (4,500 psi) at 28 days and a bond strength of 7.6 MPa (1,100 psi) at 28 days. Fiber reinforcement for the mixture was 38 mm (1-1/2 in. ) long, collated, fibrillated polyolefin fiber; coarse aggregate was saturated surface dry, conforming to ASTM C 33, size No. 8 (ASTM 1995b).

The first step in the repair process was to identify and remove the deteriorated concrete. The contractor identified areas of deterioration by visual examination and sounding the surface with hammers. Once the limits of an area of deterioration were determined, the perimeter of the area was saw cut to a minimum depth of 38 mm (1-1/2 in.), and the deteriorated concrete was removed with a chipping hammer.

Next, holes were drilled to install 1.5-m- (5-ft-) long dowels to anchor the FRAPMC to the sound concrete. The dowels were embedded in nonshrink grout. The repair area was dry sandblasted to remove any loose material and then wet to a saturated-surface-dry stage for placement of the FRAPMC.

Surface temperature for placement of FRAPMC had to be between 10 and 27 °C (50 and 80 °F). The necessary formwork was constructed and the FRAPMC placed and then wet-cured for 24 hr.

Cracks were injected with epoxy to seal them; joints were sealed with joint sealant. The epoxy was a two-component, 100 percent solids, low viscosity, water insensitive material especially made for sealing concrete cracks. Specifications for the epoxy were that it meet or exceed the following properties if cured at 24 °C (75 °F) for 7 days: flexural strength, 69 MPa (10,000 psi) (ASTM D 790) (ASTM 1995e); tensile strength, 55 MPa (8,000 psi) and bond strength, 3.4 MPa (500 psi) (ASTM C 321) (ASTM 1995c).

The injection procedure was to begin at the lowest injection port on the crack or joint; epoxy was injected until it flowed from the next adjacent port; the first port was sealed and the second port injected. This procedure was followed for the entire crack or joint. When the injection material had cured, the surface was ground flush with the adjacent concrete. Once the movement of water into the trunnion recesses was eliminated, the trunnion pits were filled with water-activated hydrophobic foam grout joint filler. In addition to being repaired, the tops of the piers that support the bridge were modified to accommodate a new two-level steel structure, which replaced the original concrete/steel bridge.

Cost for the project, including concrete removal and modification of the piers and trunnion areas, was approximately \$436,000 (October 1988 dollars).

### **Lock and Dam No. 6, Mississippi River**

Completed 20 August 1936, Lock and Dam No. 6 is located on the Mississippi River at Trempealeau, WI. The 272-m- (893-ft-) long dam consists of five 24.4-m (80-ft) roller gates and ten 10.7 m (35-ft) tainter gates. An inspection of the structure in the mid-1980s revealed areas of deteriorated concrete beneath the bridge seats and a diagonal crack that extended from the base of the bridge seat towards the bridge span. Bent anchor bolts at the expansion end of the beams and stress cracks in the deteriorated concrete suggested the damage was partially caused by the lack of expansion capability in the expansion end of the bridge beams.



Repairs were performed between November 1989 and January 1991. Deteriorated concrete around the bottom plate of the bridge seat was removed and replaced with fiber-reinforced, acrylic-polymer modified concrete (FRAPMC). New bridge seats were installed, allowing for more expansion movement of the bridge. Bent anchor bolts were straightened, and the slots in the expansion end of the bridge beams were lengthened. Cracks were injected with epoxy. The repairs have been deemed extremely effective.

Bid costs for the project were as follows (November 1989 prices): FRAPMC, \$5,400 per 1.8 cu m (9 cu ft); epoxy adhesive, \$500 for the first 3.8 ℓ (1 gal), \$750 for each additional 3.8 ℓ (1 gal); injecting epoxy adhesive, \$1,200 for the first 1.8 lin m (6 lin ft), \$2,100 for each additional 0.3 lin m (lin ft).

## Seattle District

### Chief Joseph Dam

Chief Joseph Dam, which was built in the 1950s to provide hydropower, is located on the Columbia River in north-central Washington near Bridgeport; its pool extends 82 km (51 miles) to the tailrace of Grand Coulee Dam (Figure 41). The original dam stood 70 m (230 ft) above the riverbed. The spillway structure consisted of 19 tainter gates. The powerhouse was constructed for 27 generator units; however, when the dam was completed only 16 units were installed because they supplied all the power requirements at that time. However, rapid development in the Northwest significantly increased the demand for hydropower, so from the mid-1970's to 1981, the dam was modified to increase hydropower production.

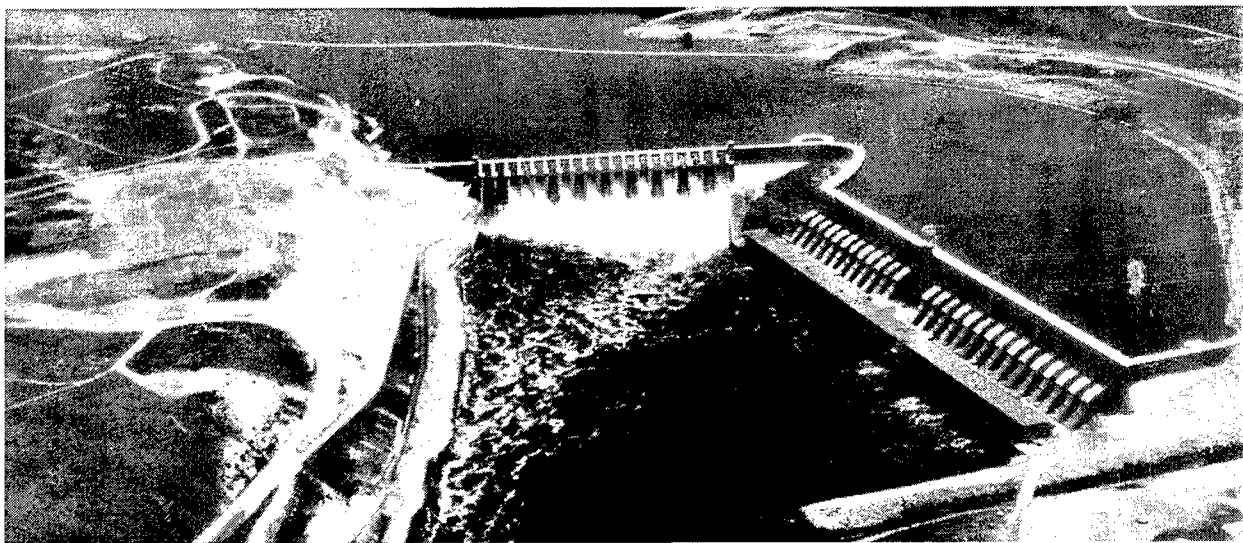

Figure 41. Chief Joseph dam with completed 27-unit powerhouse and raised dam (from Sondergard 1991b)

Modifications included raising the height of the dam by 3 m (10 ft), and installing of 11 generating units in the powerhouse to bring the total to 27 as per the original plan. Raising the dam required increasing the height of the spillway piers from 18.3 to 21.3 m (60 to 70 ft) and their width from 2.7 to 4 m (9 to 13 ft). This work had to be done without interruption of power production or the flow of the Columbia River. To solve this problem, engineers decided to use floating cofferdams that would allow several spillway bays to be dewatered at one time without the reservoir having to be lowered.

Before the floating cofferdams could be used, the contractors had to provide a way to lock them against the flat and recessed spillway abutment so they would overlap the first pier when they were first positioned. Two false piers were constructed for this purpose. They were floated to the site and lowered into place by hydraulic suspension units located on top of the dam. The false piers were permanently attached to the dam with anchors and tremie concrete. Mass concrete was used to fill the piers within 7.6 m (25 ft) of the top. The false piers were joined to a pair of boxes that made the spillway abutment and the piers even (Figure 42).

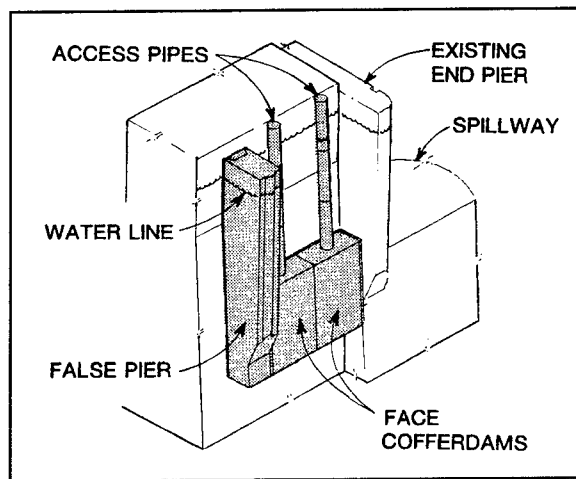

Figure 42. False pier with boxes that make spillway face and pier even, Chief Joseph Dam (from ENR 1978)

The floating cofferdams were constructed in a graving dock excavated in the shore of the reservoir. Each cofferdam weighed approximately 4,717 Mg (5,200 tons) and was floated by 20 ballast tanks connected by a network of pipes. The air-operated valves of the tanks were controlled from the deck. The hydraulic systems used to place the false piers, and come-alongs on the cofferdams were used to place the 43.6-m- (143-ft-) long cofferdams against the dam face. Double J-shaped seals were used to close off

the sides and bottom of the cofferdam. When first placed, each cofferdam was locked on a false pier and the third pier down the spillway, closing two bays for work. Afterwards, each closed three bays, so two piers could be modified before the cofferdam must be moved. (Figure 43).

To raise the height of the piers, the contractor had to first remove the reinforced concrete down to the pier bases, install dowels in the bases and rebuild the piers. Removal of the reinforced concrete required some experimentation. The piers were only 1.83 m (6 ft) from the face of the floating cofferdam, therefore, placing a restraint on blasting. Particle velocity was limited to 101.6 mm (4 in.) per second in any material that stayed in place. The

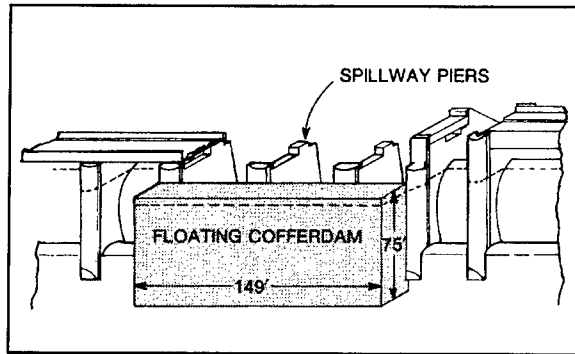

Figure 43. Floating cofferdam positioned for dewatering for pier modifications at Chief Joseph Dam (from ENR 1978)

contractor developed a plan for concrete removal that included presplitting the pier noses with drills and then placing fractions of dynamite sticks in the holes and detonating them with blasting cord. With this method, a pier top could be removed in about 3 weeks. Installing dowels and rebuilding the piers took several months (Figure 44). When work on a pair of piers was completed, the crew placed stop logs in the bays and then moved the

cofferdam to the next location. New gates were installed behind the stop logs. Also, the 16 original gates were shut down one at a time, refitted, and automated. The powerhouse was raised in two 1.5-m (5-ft) lifts and a new gallery was added for operation of the new hydraulic intake gates.



Figure 44. Piers raised and widened to resist greater head at Chief Joseph Dam (from ENR 1978)

Modifications were completed and the pool raised in 1982. Immediately leakage inflow into the spillway sump increased from below 6,183 to 13,626  $\ell$ /pm (1,800 to 3,600 gpm). By the winter of 1988-89, leakage had reached approximately 22,710  $\ell$ /pm (6,000 gpm). Variations in temperature as small as 0.6 °C (1 °F) could change the amount of leakage by hundreds of litres (gallons) per minute. The greatest flows occurred in February and March when the temperature of the concrete was at a minimum and contraction at a maximum.

Leakage was occurring through unsealed horizontal-lift and vertical-monolith joints. The drainage system in the monoliths consisted of vertical face drains that collected leakage from the lift joints and discharged it into the drainage gallery. Double-vertical copper waterstops and formed-in-place joint drains

centered between the waterstops collected water from the monolith joint and discharged it into the spillway sump. Construction activities and the increased velocity of water moving through the joint lines damaged the drainage system (Figure 45).

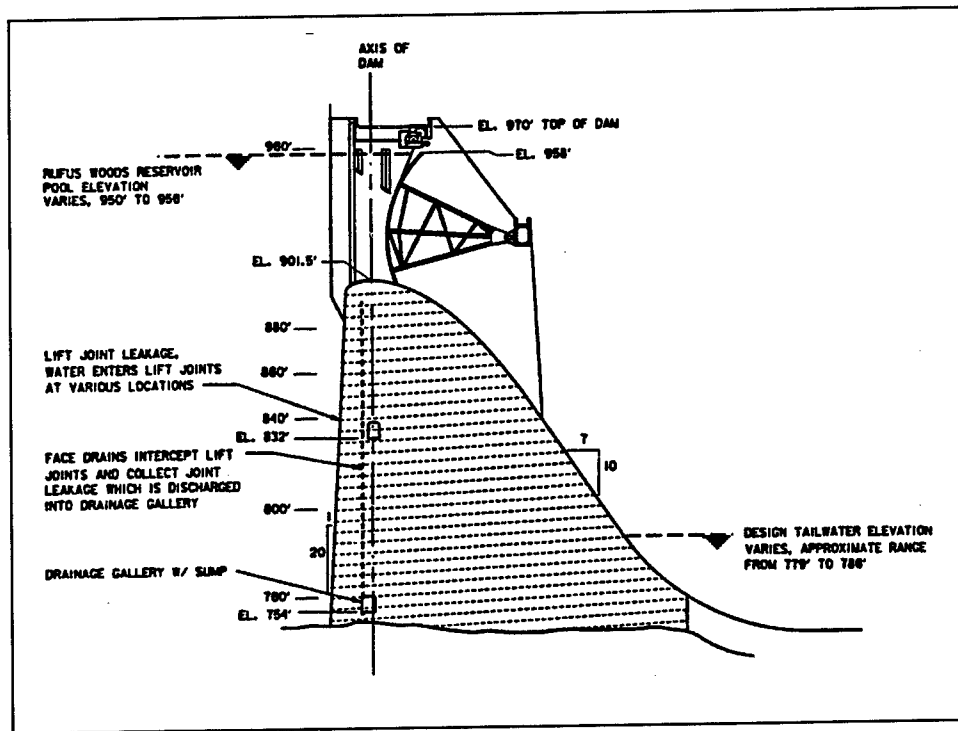

Figure 45. Monolith section showing leakage, Chief Joseph Dam (from Sondergard 1991a) (multiply feet by 0.3048 to obtain meters)

In the winter of 1981-82, a variety of materials were tested in an effort to control leakage into the structure's joints. Materials tested included compressed wood particles (presto-logs), cinders, fibrous wood, and a water-activated polyurethane chemical grout, which was applied by remote control. In the winter of 1988-89, a variety of materials and techniques were investigated in a revised approach. Wood particulate (sawdust, with a varying size gradation) was deposited in the upstream reservoir near the surface of the spillway structure. Some of the particulates were drawn into the joints, reducing leakage significantly. In March 1989, after the application of the particulate, a visual inspection of the joint entrances revealed large deposits of wood particles along the open joints. However, visual inspection in February through April 1990 disclosed that no wood particles remained. The absence of particles indicated that during the summer, when the joints close and water movement in the joints ceases, the attractive force holding the particles in the joint entrances is lost and surface currents wash the particles away.

Underwater applications of sealants containing polyurethane and silicone appeared successful in closing joint entrances and reducing water movement in the joints. The water-activated polyurethane sealant bonded to the concrete

surfaces and, according to inspection reports in the winter of 1989-90, was still effective (Sondergard 1991a).

By November 1989, monoliths that needed to be repaired had been identified, and preparations to install a valve system on the face and joint drain outlets of these monoliths had been completed. The valves would control water movement in the drains and joints and regulate velocities. The drainage system was inspected in December 1989, January 1990, and May 1990, and sources of leakage into the monolith joint drains were identified. Suspect joint entrances on the upstream face of the spillway, ranging from 27.8 to 59.6 m (71.5 to 195.5 ft) below the reservoir surface, were located with dye injection equipment. Weak, friable concrete and other contaminants were removed from the surface, and the joints were sealed during February through mid-April 1990.

The choice of a method to repair the leaking joints was based on past experience with chemical grout injection. Ten sealants were tested in the laboratory and in field trials in the winters of 1988 through 1990. The sealants were tested for low-temperature gel time and physical characteristics. The sealant selected for the repair at Chief Joseph Dam was a hydrophilic, water activated, isocyanate-based, polyurethane-forming chemical grout with a moderately high viscosity. The sealant begins reacting upon contact with water at temperatures of 1.1 °C (34 °F) and above. It requires no accelerator or material modifications.

All repairs were performed underwater. A remote-controlled camera with a 360-deg pan, 360-deg tilt, and 8-power zoom was used to monitor the repair work. A pneumatic grout pump supplied grout to the application nozzle, and a pressure pot supplied dye to leak-detection equipment. The camera, cleaning equipment, dye injection hose, lights, and grout injection nozzle were mounted on an underwater frame supported by a crane. A pneumatic motor moved the cleaning-inspection-grouting equipment along the length of the frame, which was positioned over a lift joint (Figure 46). Controls for the camera, lights, and grouting equipment were on top of the spillway bridge. As each joint was sealed, the amount of leakage through drain outflows was measured and inspected visually. The leakage reduction in each instance was significant.

The repair procedure involved locating the leakage points and applying the sealant. A pneumatic grout pump with a 30:1 ratio and up to 11.4-lpm (3-gpm) delivery was used to pump the grout. Since the water movement into the joints had a significant attractive force, the sealant not only sealed the joint entrance but was also drawn into the joint interior for a short distance (induction grouting).

The repair methods used in this project appeared to be effective on lift joints in general. Observations during repair of the monolith joints indicated that a few of the copper water stops were ineffective along their entire lengths and other monolith joints appeared to have localized points of leakage. The remedial underwater joint sealing techniques in these instances were very difficult and cumbersome. However, significant leakage reductions resulted for all monolith joints where the repair procedure was used.

Following the underwater joint sealing effort, an alternative procedure was used for repairing monolith joint leaks. The procedure used conventional drill-hole grouting and chemical grouting equipment and techniques to seal the joint drain centered between two copper waterstops spaced 0.9 m (3 ft) apart (Sondergard 1991b). These joint drains extend from the spillway ogee surface to 1.5 m (5 ft) above the foundation. Two balloon-type drill-hole packers, each 178 mm (7 in.) in diam and 1.2 m (4 ft long), were assembled in tandem with 0.6 m (2 ft) of space between them. A 165-mm- (6-1/2 in.-) diam sealed pipe was placed into this space to reduce the volume, thereby minimizing the chemical grout consumption. A compressed-air supply line, a hoist cable, and the grout supply line were attached to the top of the packer assembly. The entire assembly was positioned in the joint drain by an overhead hoist. When the packers were in the desired position, they were inflated, and then chemical grout was injected into the space between them. The grout entered the monolith joint between the water stops and filled the void. The (1.2-m-) 4-ft-long packers acted as a surface barrier to prevent the grout from exiting the joint. Injection at each location was continued until grout in the joint void reached the top of the packer. The packer assembly was then deflated, repositioned, and reinflated, and the process was repeated. The grout used was a hydrophobic, water-activated, isocyanate-based, polyurethane-foam-forming chemical grout with a viscosity of approximately 1,000 cp at 21 °C (70 °F). This method used the existing features of the structures, required no drilling or structural modifications, resulted in a sealed

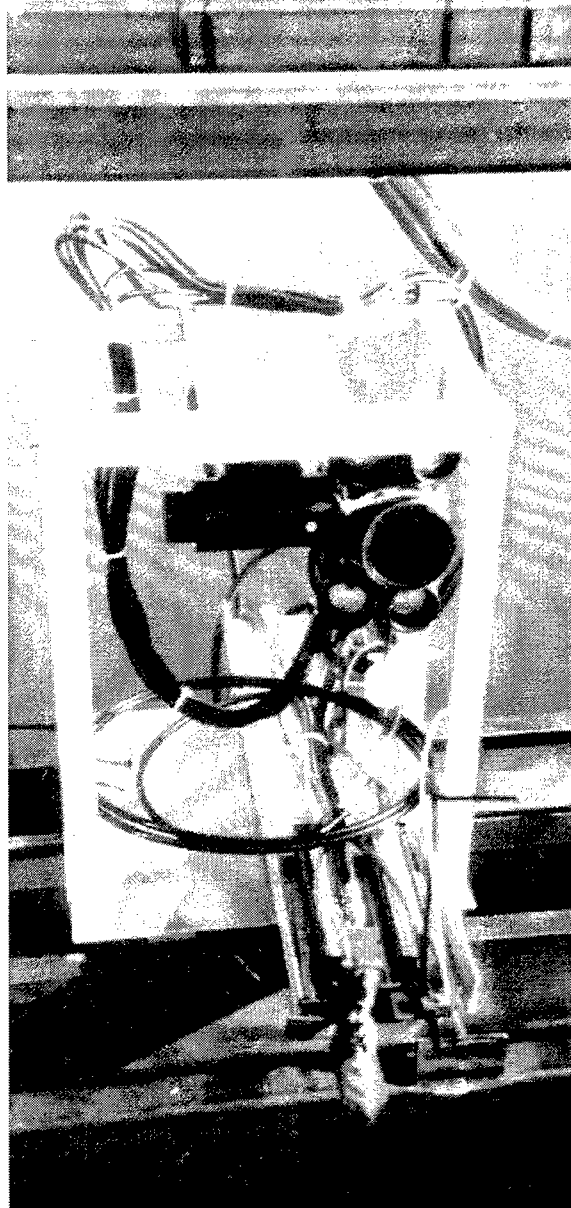

Figure 46. Frame-mounted remote-controlled camera and pneumatic equipment used for inspection and repair of monoliths at Chief Joseph Dam (from ENR 1978)

monolith joint, and left the joint drain open and functional for future inspections and touch-up sealing.

The repair procedures implemented in the winters of 1989-90 and 1991 at Chief Joseph Dam have been effective in providing significant face and joint drain outflow reductions. Drain outflow has been reduced to a small fraction of prerepair outflow.

## **New Exchequer Dam**

New Exchequer Dam is located in Mariposa County, about 48 km (30 miles) northeast of Merced, CA. The dam, which impounds Lake McClure, and an 80-MW power plant were built between 1964 and 1968 by the Merced Irrigation District to provide water for irrigation. The project also provides power generation and flood control.

The dam consists of a zoned rock-fill embankment with a concrete slab on the upstream face. At the time of its construction, it was the highest concrete-faced dam in the world. The upstream face of the dam intersects the downstream slope of an 88-m- (290-ft-) high concrete gravity arch dam. The upstream concrete slab extends through a vertical height of about 94.5 m (310 ft), and the embankment has an approximate height of 149 m (490 ft) above its foundation. The dam crest is approximately 372 m (1,220 ft) long.

Leakage had been the primary problem at the dam since construction, requiring constant maintenance and repairs as water levels permitted. The leakage was attributed to dam settlement, which was attributed to construction methods, such as the use of deep-dumped rock fill, copper waterstops, and central joints with compressible wood fillers. Also, the use of expansion joints between the concrete slabs to permit movement of the slabs allowed the slabs to conform to the settlement, resulting in joint displacement. Vertical joints in the middle of the dam tended to compress; perimetric joints and vertical joints at the abutments tended to open and become offset, thus allowing the greatest amount of leakage.

In 1983, total leakage reached about 4 cms (140 cfs) with the surface 0.6 m (2 ft) below reservoir level. Because of the increasing leakage and to eliminate the continuing costs of temporary repairs, which also adversely affect the hydroelectric plant, the District decided to perform a long-range repair. The safety of the dam was not an issue in the decision. This case history is a summary of the rehabilitation procedure described by Brown and Kneitz (1987).

The repair procedure selected was based on a review of the history of leakage, face-slab movement, and past repairs; input from the Merced Irrigation District, the Pacific Gas and Electric Company, and consultants; and a comparison of economic options. The repair was designed to provide a monolithic face slab by replacing the existing filler in the vertical and perimeter joints with mortar and grout filling voids below joints between slabs and rockfill surfaces; to restore the face slab to its original state as a watertight covering by repairing

spalled joints, filling open joints with concrete or mortar, and installing a rubber cover at joints where significant movement or leakage might occur; and installing a watertight membrane in the toe fill area.

The last comprehensive inspection of the face of the dam had been done in 1977; therefore no details of the condition of each joint were available. Joint repair specifications were designed to allow for flexibility in the performance of the repair so the joints could be inspected before a repair procedure was selected.

The construction period was determined by the need to control the reservoir level. The early forecast was that the reservoir elevation would peak toward the end of June 1985 and then be drawn down until the end of September, when it would reach the top of the old spillway gates of the old dam (el 707). At that time, the space between the old and new dams could be dewatered. The plan was to hold the reservoir at the old spillway crest (el 693) until the first of December 1985. During this time most of the work on the lower slabs and the toe fill could be accomplished. However, colder and drier conditions than normal occurred during December 1985 and January 1986, providing an extension of construction time.

A few repairs were performed in the top slabs as test repairs; several minor changes were made as a result of these repairs. As the water was drawn down, workers cleaned and chipped joints and removed existing cover slabs. The central compressed joints were cleaned with water-blasting equipment and filled with nonshrink grout. Joints that were fairly tight were filled with a nonshrink grout that could be more easily placed.

Open, leaking joints that were to be covered with rubber were filled in to provide support for the cover. Joints that had opened more than 50.8 mm (2 in.) were filled in with a concrete wedge (Figure 47). The wedge would provide support for the joint cover for up to 76 mm (3 in.) of future joint opening. Workers chipped out the joint to a "V," or wedge, shape. Irregular surfaces left by the chipping equipment were plastered with cement mortar or dry-mix shotcrete. Next, a Deery membrane, which is a low modulus, highly resilient, adherent material commonly used for lining ponds, was installed in the joint. Shotcrete was then placed against the membrane and screeded even with the top of the opening. Welded wire fabric was used to provide reinforcing for some of the wedges.

The joint covers were constructed at the site. All of the necessary materials were purchased except for the Deery membrane, which does not come in the size needed for the covers. The membrane is produced from a liquid, which is heated up to 204 °C (400 °F), poured into a form, and allowed to cool. Personnel from the Deery Oil Company made the 0.9-m (34-in.) strips used for the joint covers at the dam site. Thickness of the membrane varied from 9.5 to 16 mm (3/8 to 5/8 in.).

To install the rubber joint covers, workers placed strips of Deery membrane over the shotcrete, then nitrile sheets and steel cover plates. Holes were drilled



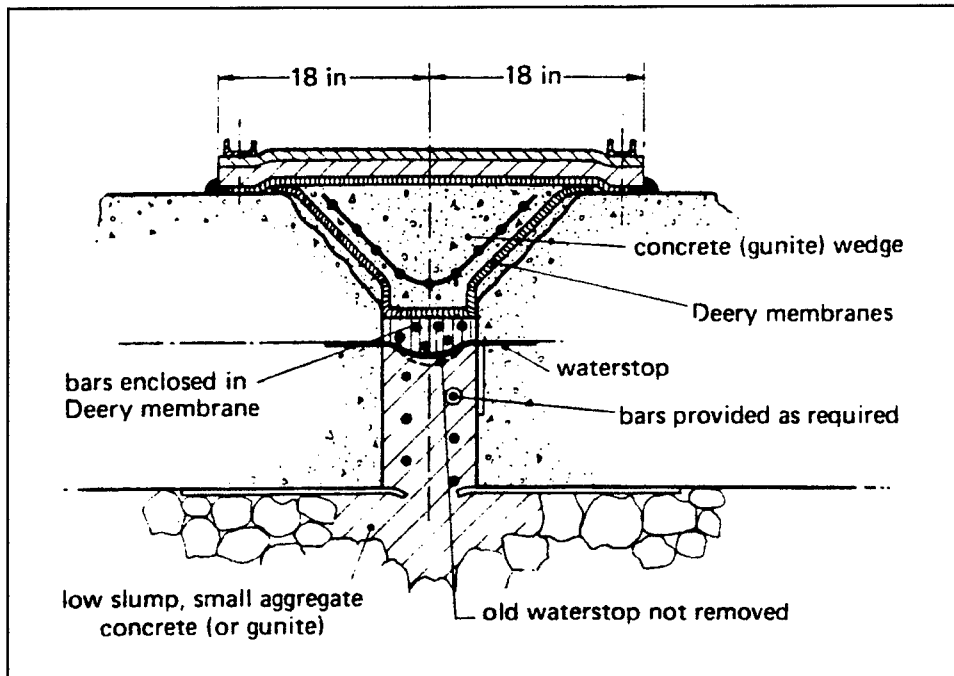

Figure 47. Details of repair for open, leaking joints at New Exchequer Dam (from Brown and Kneitz 1987)

for anchor bolts and the bolts were installed and tightened with a torque wrench. A sealing compound was placed at the edges of the joint cover between the nitrile and the concrete face slab (Figure 48).

Open joints that had leaked in the past were inspected for voids. The voids were filled with a sand-cement grout mixture, which was typically injected through holes in the waterstop. In those joints where the copper waterstop was torn, the waterstop was removed and the void was filled with shotcrete.

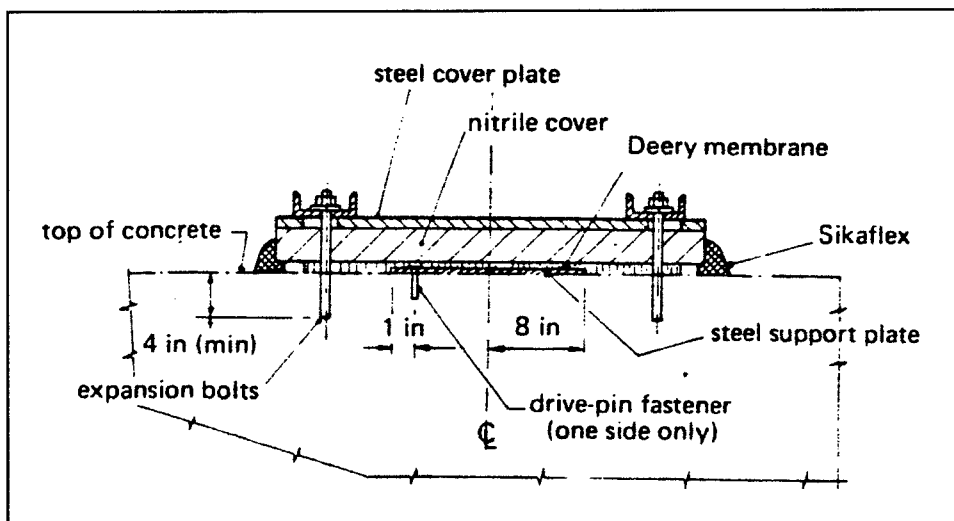

Figure 48. Details of joint covers used at New Exchequer Dam (from Brown and Kneitz 1987)

Shotcrete was used to repair spalled joints. The spalled concrete was chipped out and removed, and a thin layer of cork was placed in the joint to help with load transfer before the shotcreting was done. If the spalled area was deep, reinforcing was added to help anchor the new concrete to the existing slab.

Although the toe fill was in good condition, with no sinkholes, the repairs planned for this area were completed (Figure 49). Two light bulldozers were used to remove extraneous material and grade the fill. Next, a layer of geotextile was placed over the fill, followed by imported material dumped from the crest of the old dam and spread by the dozers. This material was covered with a second layer of geotextile. A watertight geomembrane was placed over this layer of geotextile. The geomembrane had been precut and seamed in three large panels. An additional piece had to be added because of the difference between the expected and actual toe-fill geometry and to provide for adjustment of the membrane to the toe fill after the reservoir filled. A tented enclosure and heaters were used to maintain proper temperatures for making the field joints.

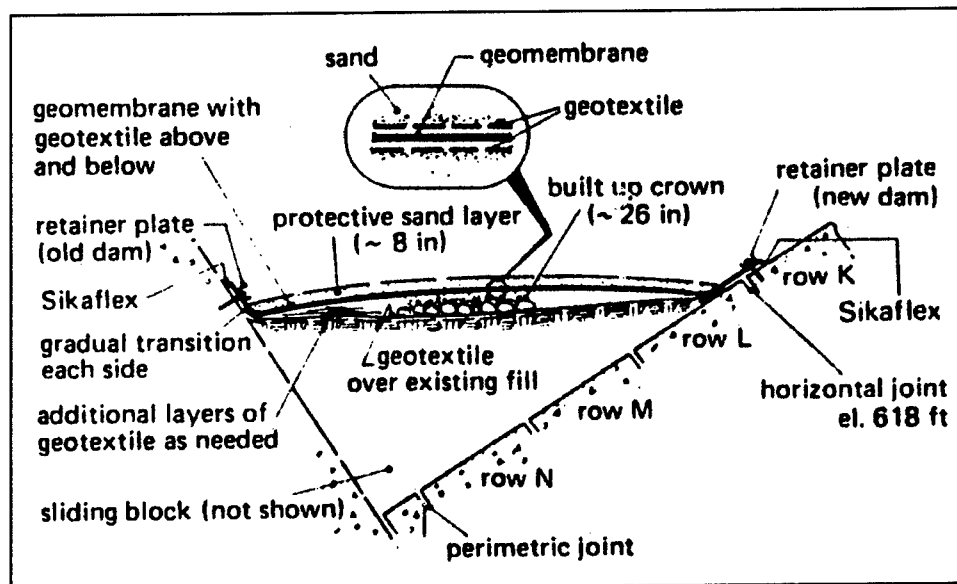

Figure 49. Details of installation of geomembrane over toe fill at New Exchequer Dam (from Brown and Kneitz 1987)

The geomembrane was covered with a layer of geotextile topped with a layer of sand. The entire toe-fill repair was carefully wetted, and then the area was rewatered. By mid-January 1986, the water level had reached el 706 and had a static head of 26.8 m (88 ft) on the surface of the toe fill. No measurable leakage had occurred. The reservoir continued to fill; not until 3 March 1986, were traces of leakage noted. When the reservoir peaked 28 June 1986, 3.4 m (11 ft) below normal maximum reservoir level, leakage was 0.098 cms (3.5 cfs), a significant reduction when compared to leakage of 3.9 cms (140 cfs) at this same level in 1983. Leakage at the dam reported in July 1986 was 0.1 cms (3.7 cfs). Some personnel believe as much as half of this amount is coming through the old dam gallery and the new dam access gallery.

The repairs to New Exchequer Dam were made over a 9-month period and cost approximately \$3.5 million. Since the main source of the leakage has been eliminated, the cost of the repairs is expected to be recovered soon through increased flows available for the hydroelectric plant and the elimination of costs for temporary repairs.

## Walla Walla District

### Dworshak Dam

The multipurpose Dworshak Dam and Reservoir is located on the North Fork Clearwater River in central Idaho. This straight-axis, gravity-type dam has an overall structural height of 218.5 m (717 ft) and 52 monoliths that create a total crest length of 1,002 m (3,287 ft). South of the hydroelectric power plant and contiguous to the left riverbank is a chute-type spillway overflow with two 15.2- by 16.8-m (50- by 55-ft) tainter gates that control flows above elevation 1,545 ft. Three regulating outlets provide release of the reservoir to pool el 1,440 msl by way of 3.4- by 5-m (11- by 16.5-ft) tainter valves.

Before the reservoir was filled in 1971, cracks on the upstream face of several monoliths were measured and mapped to pinpoint their exact location and length. At that time, the cracks were not regarded as being significant. After reservoir filling, eight of the cracks that were mapped penetrated the interior of the structure, causing an inflow of water into several galleries. These cracks were drilled to release hydrostatic pressure. After the drilling was completed, flows decreased, and over time most of the cracks healed as a result of calcification. New instruments for monitoring cracks and other areas where stresses were occurring were added to the resistant thermometers, pressure cells, stress meters, and joint meters that had been installed during construction of the dam.

One of the cracks was a thermal crack on the upstream face of Monolith 35. Over the course of the next couple of years, the crack extended farther into the structure and penetrated the drainage and grouting galleries. The crack, which had been partially healed by calcification, reopened in the fall of 1979 when holes were drilled into an adjacent contraction joint to release water that had collected between the two waterstops. The crack width gradually increased during the following spring pool filling time. Then on 30 May 1980, the crack extended and widened unexpectedly, allowing 0.38 cms (13.37 cfs) of water to enter the internal drainage system. The initial cause of cracking was thermal stresses during the curing process; its propagation was due mainly to penetration of cold water into the warm concrete interior causing the concrete to contract.

Drilling crews drilled holes into the crack to relieve the high water pressure and thereby stop the propagation and to define the limits of the crack so that a rational stability analysis could be performed. Crack propagation was stopped, and flows were reduced, but this time the chance that the crack would be healed by calcification was slight. It was, therefore, necessary to repair the crack

permanently. As a temporary repair measure, a vinyl membrane curtain was placed on the upstream face of the dam over the upper part of the crack to reduce the amount of water entering the crack system in Monolith 35. The first step in this plan was to perform an underwater TV scan of the crack. This scan revealed that debris protruded from the crack for its full height. The debris would have to be removed. Divers could not be employed for the work because the depth of the crack exceeded 51.8 m (170 ft), the legal depth at which they can work.

On June 6, 1980, engineers completed a preliminary design for the equipment, known as the traveller, that would be used to scrape away the protruding debris from the crack and place the vinyl membrane curtain. A number of curtain materials were evaluated. The one selected was made of a 25-mil nylon, reinforced vinyl material. The material was ordered in 4.6-m- (15-ft-) wide strips. The strips were wound on a 203-mm- (8-in.-) roller, which was attached to the traveller. Steel plates, 127 mm (5 in.) square by 3.2 mm (1/8 in.) thick were used to fasten the curtain against the upstream face of the dam. An underwater impact gun that fires 0.38-caliber cartridge pins was used to fasten the steel plates to the dam and for anchoring the wood filler strips that were placed in the joint rustications within the drawdown area.

The traveller was managed with a fare lead from a barge and a truck crane located on the dam roadway deck. The free end of the vinyl curtain roll was wrapped around two 0.6- by 2.4-m (2- by 8-ft) boards, which were anchored to the wall with a 19-mm- (3/4-in.-) diam bolt and concrete expansion anchor after the curtain was plumb. The first attempt to place the curtain was difficult as a considerable amount of material had unwound from the roller before the traveller had gone very far below the water surface. The slack curtain could not be rerolled without removing the traveller from the water. Once technicians learned how to adjust the brake on the roller so it would provide enough drag to keep the curtain taut during placement, they had no further incidents. The crack was covered with three strips of curtain, each with a 1.5-m (4-3/4-ft) overlap. Two vinyl membrane curtains were placed. There was an immediate reduction in flows of approximately 6,050 lpm (1,600 gpm). (Although a majority of the decrease in flow was attributed to the center face drain in monolith 35, additional crack drain holes were being drilled during this time to reduce crack pressure, so the reduction amount is only an approximation.) However, this project showed that vinyl curtains can be placed as temporary surface sealers; they are effective in reducing seepage and/or leakage, and they can be inexpensive. The total cost of all underwater work was \$29,979.75; the vinyl membrane cost \$5,803.87.

The permanent solution selected was to seal the crack with an epoxy material designed to be placed underwater. Technicians first had to remove the vinyl membrane curtain; this work was completed early in May 1981. Before applying the epoxy, workers dumped a mixture of wood fiber, volcanic cinders, and cement down the face of the monolith. The material was sucked into the crack and reduced flow. Divers chipped out the crack and prepared the surface for the epoxy injection. Some of the epoxy was sucked into the crack because the crack filler did not completely seal the crack. The "suckers" ranged in size from pin holes to approximately 0.5 m (1-1/2 ft). These areas were plugged with various

lengths of rope with diameters from 4.8 to 8 mm (3/16 to 5/16 in.), which was then embedded in epoxy. Divers worked 2 years repairing the crack. The work was slowed by existing reservoir control restraints and excessive diving depths. The repair was performing satisfactorily 1 year after placement (American Society of Civil Engineers (ASCE) 1988).

The contractor mentioned several design changes that could prevent such incidents from happening in future structures: more closely controlled concrete placing temperatures, improved cold weather protection, and changes in locations of waterstops, or grouting the contraction joints.

In the late 1980s, erosion resulting from the grinding action of riprap and trapped debris caused a loss of almost 1,220 cu m (1,600 cu yd) of concrete in the stilling basin, and the outlet conduit suffered cavitation damage when excessively high flows washed out large pieces of aggregate and matrix from the face of the outlet. Both the stilling basin and the outlet conduit were repaired with polymer-impregnated concrete in the first major field application of this repair material (Denson 1989).

Periodic Inspection Report No. 11 (USAED, Walla Walla 1997) reported that the crack in Monolith 35 and monolith joint 34/35 had experienced no movement during the past year; however, joints 35/36 and 36/37 had opened up as a result of joint pressure and increased water leakage during full pool. Instrumentation as well as visual inspection is being used to monitor the existing conditions. Flows from drains are also being monitored.

The stilling basin was last inspected in September 1993. However, there is some concern about the accuracy of the inspection: the Contractor was required to use state-of-the-art equipment, which produced excessive data, which the Contractor had difficulty handling. Also, the fact that the actual floor elevation of the stilling basin was 0.3 m (1 ft) above where it should be suggests the contractor had difficulty establishing water elevations. Since the raw data indicated no severe debris piles or erosion holes, a new inspection was not performed. The next inspection is scheduled for FY 1999 (USAED, Walla Walla 1997).

### **Lucky Peak Dam**

Lucky Peak Dam, located on the Boise River near Boise, ID, became operational in 1955. It is an earth and rock-fill structure with a silt core and rock slopes. The dam is 103.6 m (340 ft) high, and its crest is 713 m (2,340 ft) long. It has an ungated, 1829-m (6,000-ft) ogee spillway that discharges into an unlined channel.

The outlet works is a 7-m- (23-ft-) diam steel conduit that directs water to a manifold structure that has six outlets, each controlled by a slide gate. The manifold also has a 762-mm (30-in.) hollow jet valve that is used to regulate discharge during low flows. Flip buckets constructed directly downstream of

each slide gate lead to the 45.7- by 45.7- m (150- by 150-ft) stilling basin, which was excavated into basalt rock.

Cavitation became a constant problem once the dam was placed in operation. One source of the problem was thought to be the design of the flip buckets. The design was based on a model study made for the project. Data from the model study indicated that, under certain conditions, cavitation erosion would occur within and downstream of the gate slots. However, the decision was made to proceed with this particular system under the belief that cavitation damage could be controlled by restricting gate operation. An additional point of interest is that the slot configuration/gate-leaf relationship, detailed in the original contract was not constructed; a substitution was made that deviated from model study geometry. This deviation may partially explain why model study predictions and actual prototype damage differed by such a large degree. The final outlet alignment, flip bucket, and stilling basin designs were determined by the model study.

An inspection made in July 1955 revealed extensive erosion of the concrete inverts of the outlet channels and flip buckets downstream of the gates (USAED, Walla Walla 1983). Eroded areas extended from the gatewells into the flip buckets to maximum depths of approximately 1,016 mm (40 in.) (Figure 50). The flip buckets were repaired during the winter of 1995-1996. The concrete floor of each of the channels was removed to the depth of the erosion, and the side wall concrete was removed to a depth of 203 mm (8 in.) for a height of 2.4 m (8 ft) above the channel floor. This procedure was carried out for the full length of flip bucket no. 1. Concrete was removed from the other outlet channels only to the end of the pier nose. A steel plate was then anchored to the concrete, grout was pumped through holes in the plate, and the holes were patched with steel plugs and ground smooth. Repairs were completed in March 1956.

An additional problem with the flip buckets was the hazardous conditions the spray produced on Highway 21 (Figure 51). To resolve this problem, the outlet channel and flip bucket were modified. In 1958, flip bucket no. 3 was cut from 0.61 to 0.31 radians (35 to 18 deg), and a training wall that extended downstream from the right pier nose was added. These modifications improved conditions with the spray, but the training wall eroded badly during operation of the flip bucket. Because the modifications had helped with the spray problem, a decision was made in 1961 to cut back flip buckets no. 2, 3, and 4 to 0.2 radians (12 deg) and to line the training walls on both sides of these buckets with 19-mm (3/4-in.) steel plates (Figure 52). Operation of flip buckets no. 5 and 6, which generated excessive spray and were closest to the highway, was limited. Flip bucket no. 5 was later modified to a 0.68-radian (39-deg) flip angle. Although the changes in angles reduced the spray problem, they caused an erosion problem downstream of each of the modified flip lips that threatened to undermine the existing training walls. Also, the downstream edges of the flips on buckets no. 2, 3, and 4, which were still concrete, had eroded down to the reinforcement. In 1972, steel liners had been placed downstream of flip buckets no. 2, 3, and 4; by 1974 the liners downstream of flip buckets no. 3 and 4 had been torn out.

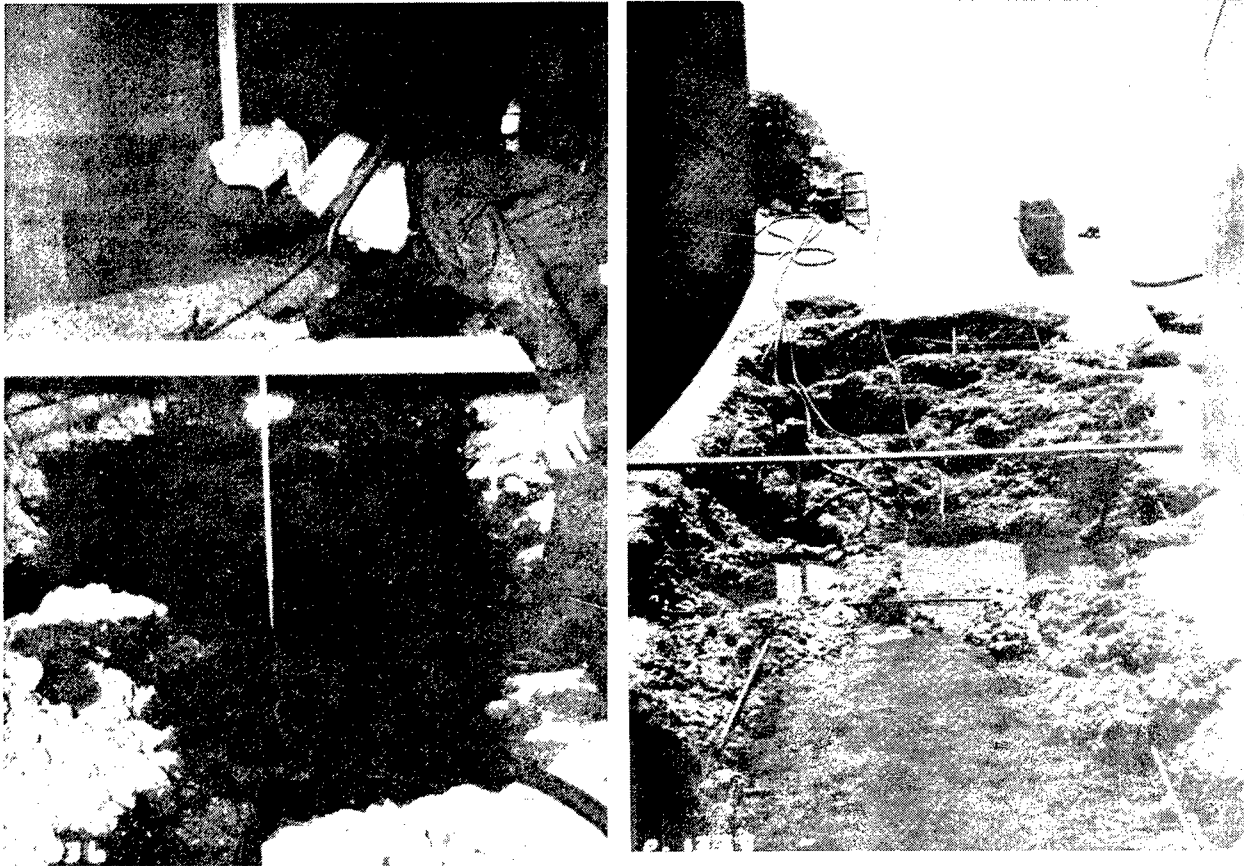

Figure 50. Upstream (left) and downstream views of cavitation in flip-bucket floor in channel no. 1, Luck Peak Dam (from U.S. Army Engineer District, Walla Walla 1983)

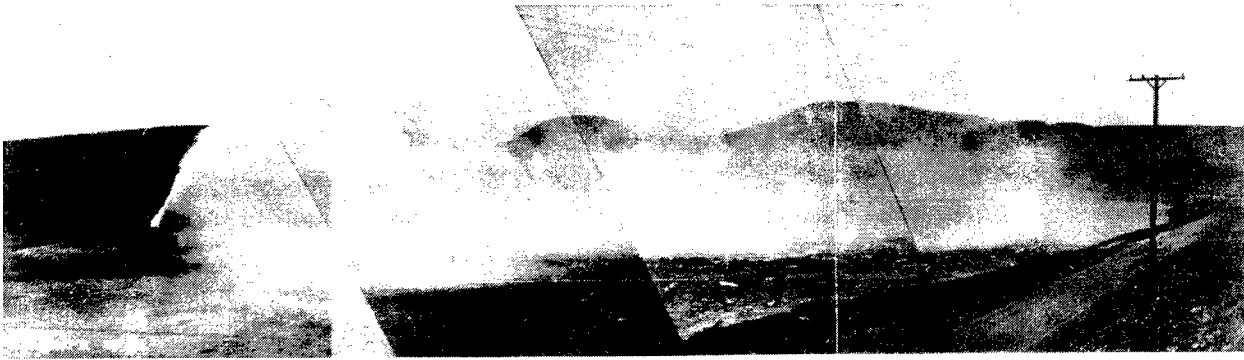

Figure 51. Spray from outlet no. 5 reaches Highway 21, Lucky Peak Dam (from U.S. Army Engineer District, Walla Walla 1983)

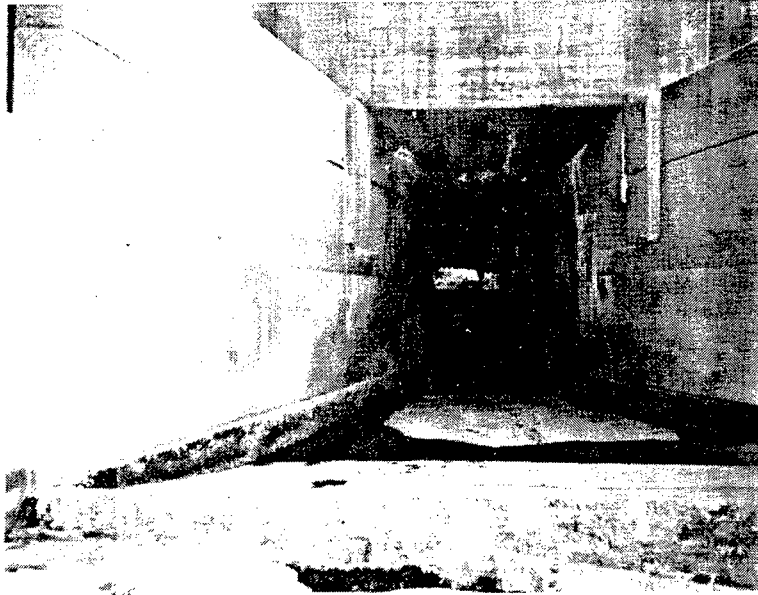

Figure 52. Outlet channel of flip bucket no. 4 with steel plates on the walls, Lucky Peak Dam (from U.S. Army Engineer District, Walla Walla 1983)

In 1974, a hydraulic study of the outlet was conducted. The study concluded that the major factors contributing to the erosion damage on the concrete aprons downstream of the modified flip buckets were the reduced flip angle of the affected flip buckets, the deterioration of the flip lip, normal air flow to the underside of the flow jet being blocked by the training walls, and high-velocity flows, in the range of 2.5 to 3.5 cu m/s (88 to 124 fps).

In 1972, cavitation damage in the flip bucket channel floors were repaired with fibrous concrete. In 1984, a contract was let for repair of the outlet work. The alternative selected for these repairs was to: (a) fully cover the floors of each flip with 19-mm (3/4-in.) steel plate, including the vertical faces at the edge of the flip lip; (b) to restructure Channels 2, 3, and 4 with provisions for air vents in the training walls to supply air to the channel floors just downstream of the flip lips (wall heights in the area of the air vents would be raised by 1.5m (5 ft) to raise the air intakes above the level of the waterflow and prevent suction of water into the air vents); (c) fully line Channels 2, 3, and 4 with steel (Figure 53); (d) patch and repair the existing concrete surfaces of Channels 5 and 6; (e) cut back and resurface the concrete aprons of Channels 3 and 4 to provide a 10 percent downstream slope from the edge of the flip lip; (f) replace the severely damaged training walls 2, 3, and 4 with new 19-mm (3/4-in.) steel welded to W10 × 45 columns and filled with concrete; and (g) establish a mandatory operation schedule for flip buckets 5 and 6 to minimize road hazard, making sure the gate would be operational in an emergency.

In addition, the piers and invert were strengthened with 32-mm- (1-1/4-in-) thick steel plates, stiffened at 1.5-m (5 ft) intervals with steel rods. Concrete was placed between the pier plates and mortar backfill was pumped behind the



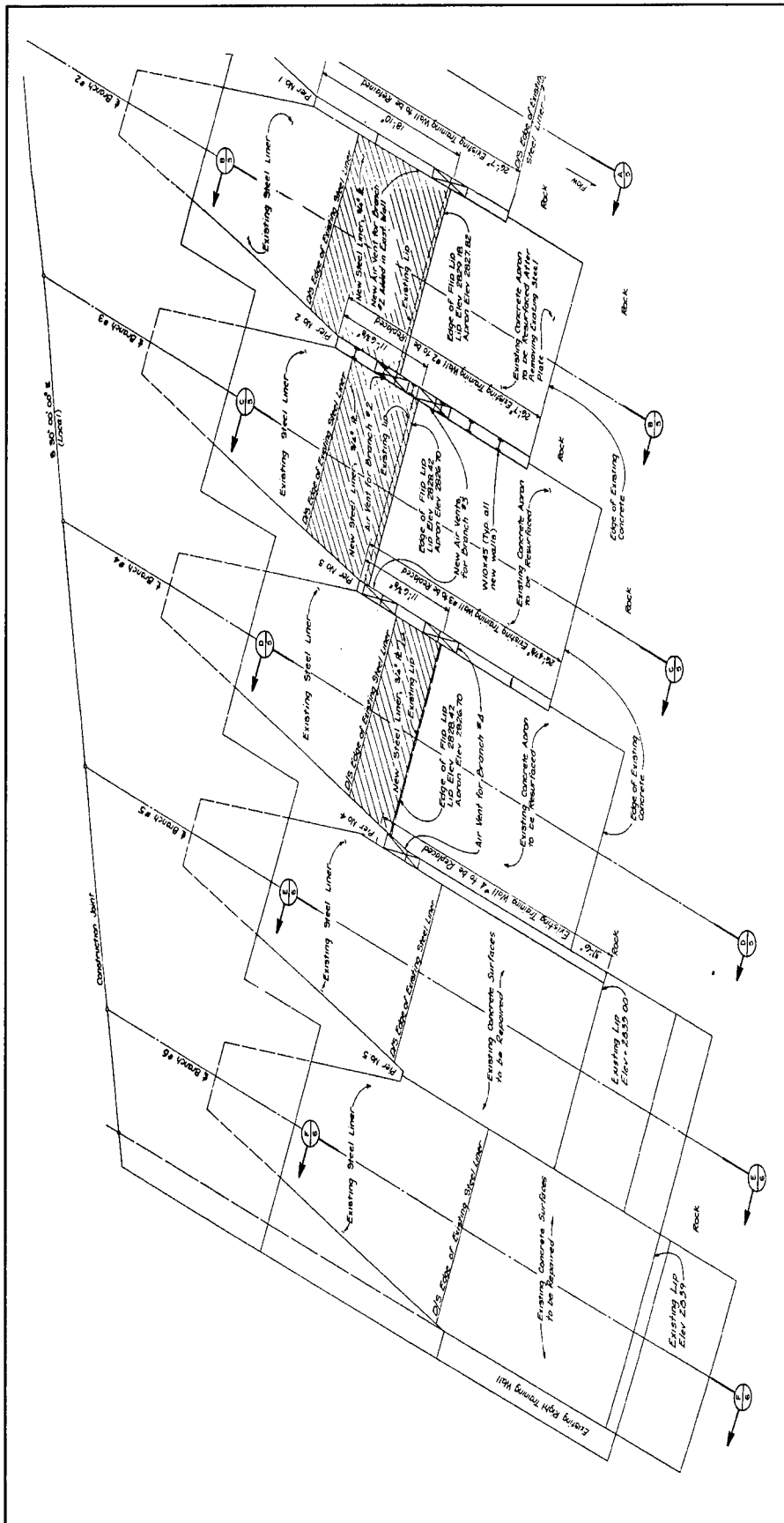

Figure 53. Plan for repairing outlet works, Lucky Peak Dam (from U.S. Army Engineer District, Walla Walla 1983)

invert plates. No further work was done because modifications to the powerhouse would nearly eliminate usage of the outlet. Following 1 year of greater-than-average usage of Bays 3 and 4, cavitation had worn through the protective steel plates on the side piers downstream of the gates and about 152.4 mm (6 in.) into the concrete; the invert plates, however, showed no signs of cavitation. - Since the completion of the powerhouse, the use of these gates has almost been discontinued.

At the time of Periodic Inspection Report No. 7 (USAED, Walla Walla 1989), the repairs to the flip bucket chute inverts and walls were performing well; they would continue to be visually inspected in the future.

## Huntington District

### Alum Creek Dam

Alum Creek Dam is located on Alum Creek north of Columbus, OH, in Delaware County. The dam is a rolled earth-fill embankment. It is 28.3 m (93 ft) high and has a crest length of 3,048 m (10,000 ft). The spillway is located on the right abutment. The spillway raceway empties into a stilling basin. Three 10.4 by 7.6-m (34- by 25-ft) tainter gates are used to control the flow. The tainter gates are supported by 24.8-m- (8-ft-) wide concrete piers atop concrete ogee sections with a crest elevation of 878. Constructed between 1970 and 1974 and operated by the USACE, the dam and reservoir provide flood-control, water storage, and recreational opportunities.

Although the monoliths were designed to resist overturning, failure of the rock in bearing, and sliding on the foundation or any seam in the foundation, there was concern that sliding would occur because of the soil on which the dam was constructed. The Ohio Black Shale at the dam site is a hard, massive silt shale with clayey seams. Cores taken for inspections indicate that occasionally contacts between the seam and the shale are clayey coated.

Barnes (1982a) reported on the 1975 periodic inspection and subsequent anchoring of the spillway monoliths. This case history is a summary of his report. One hundred fifty-two and four tenths-millimetre-(152.4-mm- (6-in.) cores were drilled into the raceway to obtain samples of the weak foundation seams. Because clayey seams were found in a significant number of cores, specimens were taken for laboratory testing to determine shear strength parameters. The shear strengths from the laboratory tests and the latest analytical criteria were used to perform a deep-seated sliding analysis. Test results indicated that the spillway monoliths should be anchored with high-capacity rock anchors.

Loading conditions and assumptions used in the sliding analysis were also used in designing the anchors. A minimum shear-friction factor of safety of 1.5 was used. The anchor design was for seven 5,780-kN (1,300-kip) anchors per

monolith to be installed at 0.79 radians (45 deg) (Figure 54). Each anchor was constructed with 53 seven-wire high-strength strands with a working stress of 1,103 MPa (160 ksi).

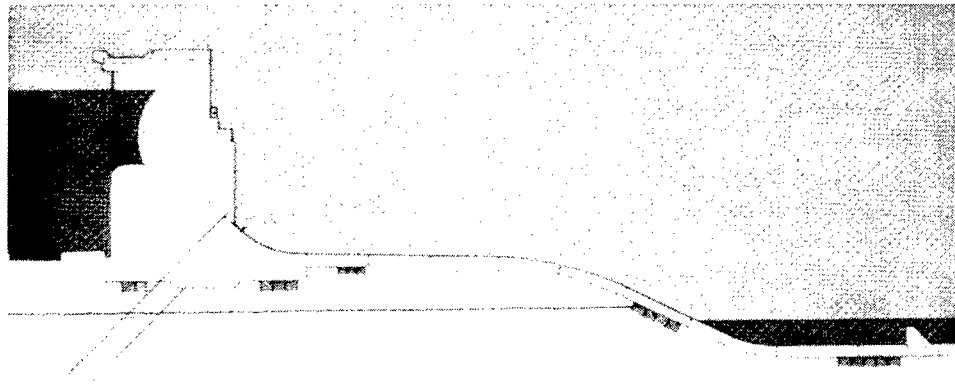

Figure 54. Anchoring spillway monoliths at Alum Creek Dam (from Barnes 1982a)

With an initial stress of 6,817 kN (1,532.5 kips) plus seating losses, anchors were subjected to a test lift-off at 1 hr and at 14 days subsequent to stressing to determine losses in the anchor. If the anchor had fallen only to load capacity 6,227 kN (1,400 kips) by day 14, any following loss was expected to merely reduce the stress to the original design capacity of 5,780 kN (1,300 kips).

To secure an anchorage zone beneath all suspected weak seams, each anchor was installed at an elevation below the stilling basin slab. Stress concentrations in the rock were avoided by staggering anchor hole depth. Three bell anchors were installed in each anchor zone to provide positive anchor resistance. An allowable bearing value of 3.5 MPa (500 psi) for the bell-against-rock and an allowable grout-to-rock shear value of 0.062 MPa (90 psi) were used to determine an anchor length of 9.5 m (31.2 ft). At the top of each anchor hole, a 0.9-m- (3ft-) wide and 0.9-m- (3ft-) deep hole was drilled in the face of the spillway to accommodate the installation of bearing plates and supporting concrete, as well as anchor-head and strand extensions.

VSL Corporation was awarded the contract to install the anchors at a price of \$254,777.50. Drilling commenced on 15 June 1977 from a contractor-designed work platform that was towed across the raceway. Anchor hole size was modified from 229 to 356 mm (9 to 14 in.) to accommodate the contractor's equipment. To offset bearing area losses, the bell anchor diameter was altered from 533 to 610 mm (21 to 24 in.) All holes were drilled, grouted, and redrilled to ensure that all voids were filled. Drilling was completed on 24 August 1977. Bearing plate concrete was placed on 23 and 26 August. Specifications required the high-strength concrete to have a minimum compressive strength of 27.6 MPa (4,000 psi) before the anchors were stressed. Seven-day compressive strength for anchors placed Aug. 23 ranged from 30.6 to 33.6 MPa (4,440 to 4,880 psi); for those placed Aug. 26, 27.9 to 28.5 MPa (4,060 to 4,130 psi). Twenty-eight-day compressive strength for anchors placed Aug. 23 ranged from 41.9 to

42.3 MPa (6,080 to 6,130 psi); for those placed August 26, 37.8 to 38.5 MPa (5,480 to 5,580 psi).

Another contract alteration allowed the contractor to use a 52-strand anchor with a minimum of 1,900 MPa (275 ksi) per strand instead of the designed 53-strand anchor with 1,700 MPa (250 ksi). The strands were cut and bound together (Figure 55) to form an anchor. A helicopter was used to install the anchors; each anchor unit weighed approximately 1,540 kg (3,400 lb). The operation was completed in 5 hr on 6 September 1977. The next 3 days were used to grout the anchors in place. The grout contained 19 ℓ (5 gal) of water per bag of cement and 1-percent Intraplast-N. Fifty one-millimeter- (2-in.-) cube specimens were taken and tested at both 7 and 21 days; they passed the contract specification of 27.6 MPa (4,000 psi) with compressive strengths of 29.1 and 42.7 MPa (4,220 and 6,200 psi), respectively.

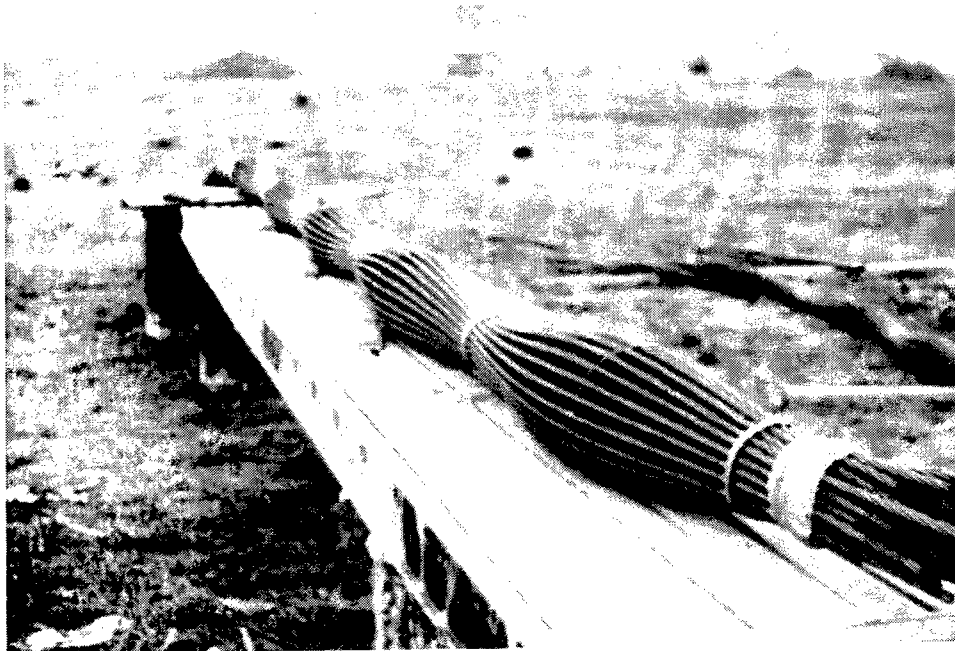

Figure 55. Anchor strands, cut and bound, for Alum Creek Dam (from Barnes 1982a)

When the grout reached a compressive strength of 27.6 MPa (4,000 psi), the anchors were stressed. Each strand of each anchor unit was pulled to 13 kN (3 kips) to remove slack in the system, and then the entire unit was stressed in increments of 20 percent to 100 percent of 6,800.5 kN (1,528.9 kips). This load was supplied by a 907-Mg (1,000-ton) center hole jack with a gauge attached to measure the pressure. An initial lift off was conducted to determine the quantity of load remaining in the anchor. The load was then released from the jack, and after a minimum of 1 hr, the jack was reloaded and a second lift off made. The anchors were again tested at 14 days.

Second-stage grouting was conducted to ensure positive corrosion control after the 14-day anchor lock-off. To complete the project, concrete that had spalled when the 0.9-m (3-ft) hole for the anchor head was drilled was repaired.

## **Delaware Dam**

The Delaware Lake Dam, completed in 1948, is located on the Olentangy River approximately 6.4 km (4 miles) upstream of the City of Delaware in Delaware County, Ohio. The dam is a homogeneous, rolled impervious earth-fill structure with a concrete gravity spillway section. The dam has a maximum height of 28m (92 ft) and a crest length of 5,670 m (18,600 ft). Its maximum flood pool is 162,822,000 cu m (132,000 acre-ft) of water. It was constructed for flood control, recreation, and water supply.

The concrete spillway consists of conventional overflow ogee weir sections with a crest elevation of 922. Its overall length is 7.0 m (232 ft). Low flow is controlled by five 2-m- (6.5-ft-) square gated sluices passing through the spillway section and discharging into the stilling basin. High flow is controlled by six tainter gates, each 7.6 m (25 ft) high by 908 m (32 ft) wide.

The top sloping surfaces of the spillway training walls exhibited a moderate amount of irregular, intermittent cracking and spalling. During the first periodic inspection, maintenance-type repairs were recommended. By the time of the second inspection, the left wall had deteriorated somewhat (USAED, Huntington 1990a). An investigation of the concrete revealed an insufficient amount of entrained air in the concrete and deterioration that was likely caused by cycles of freezing and thawing. The final construction report indicates that the concrete contractor initially furnished an air-entraining admixture interground with the cement, but the admixture apparently failed to entrain the desired amount of air. Use of the air-entrained cement was later phased out, and an air-entraining admixture was added to the portland cement at the project site. However, no mention is made of insufficient air-entrained concrete ever being removed and replaced.

In June 1983, a contract was awarded for \$725,412 for the removal and replacement of deteriorated concrete. Construction drawings of the concrete repair of the training walls are contained in Periodic Inspection Report No. 5 (USAED, Huntington 1990a). Most of the sloping surface of the walls was removed and replaced. Other areas of deterioration on the surface of the walls were removed to a minimum depth of 305 mm (12 in). The replacement concrete was reinforced with No. 5 bars, 305 mm (12 in.) on centers both ways and anchored to the existing concrete with No. 6 anchors. The Fifth Periodic Inspection (USAED, Huntington 1990a) noted that the repair was performing well.

The stilling basin was first inspected in August 1971 by divers. They found a significant quantity of stones and moderate damage. During the second inspection (1975), the basin was dewatered to a depth of approximately 0.6 m (2 ft)

(USAED, Huntington 1990a). The inspection team found large accumulations of stone, sand, and gravel, as well as irregularities in the floor and abrasion on the baffles. The debris was removed from the basin, but no repairs were made. A third inspection in July 1980 found the basin to be in the same condition as it was in 1975 despite having been cleaned out. Stone, sand, and gravel deposits had recurred in the same pattern. Damage to the concrete appeared about the same, except for a hole downstream of sluice 1 behind the first row of baffles. Here, the depth of erosion had increased from 508 mm (20 in.) in (1975) to more than 0.9 m (3 ft).

An investigation revealed that the normal method of gate operation was to use Gates 1 and 2 for control. When the required outflow exceeded the capacity of these gates, other gates were opened. However, because of the manner of operation, swirling, erosive currents were created when Gates 1 and/or 2 only were in use. These currents tended to bring in sand and gravel particles from downstream and deposit them in the basin. Also, the agitation of these particles caused damage to the concrete. Since then, the method of gate operation has been revised to a uniform opening of all gates. This revision has eliminated the undesirable eddy effects in the basin.

In October 1980, the stilling basin was dewatered and repair work performed on the two largest holes on the right side, downstream of sluice 1. Approximately 5 cu m (6-1/2 cu yd) of 20.9-MPa (3,000-psi) concrete was placed in the holes to bring them to the general level of the basin floor. Some existing reinforcing steel was left exposed at the base of the baffle downstream of the largest hole. No other areas were patched or repaired. One small area (approximately 0.9 sq m (10 sq ft)) within the largest hole was coated with epoxy to improve the bond between the new concrete and the old. No anchors or reinforcing bars were added.

For the Fifth Periodic Inspection (USAED, Huntington 1990), the basin was dewatered and cleaned. Very little debris was present. It was noted that the concrete used to repair the erosion hole below sluice 1 had popped out and the hole was again in need of repair. No other deterioration of concrete was noted.

### **Mohawk Dam**

The Mohawk Dam is a dry dam located on the Walhonding River approximately 26 km (16 miles) above its convergence with the Tuscarawas River. Its primary function is flood control. The embankment consists of an impervious core, pervious layers, and an outer rock-shell covering. The original structure had a maximum height of 33.8 m (111 ft), a crest length of 710 m (2,330 ft), and crest width of 10.7 m (35 ft) at el 910. The outlet works, located in the left abutment, includes an intake structure, two 6-m (20-ft) horseshoe conduits, six 2.4 by 5.2-m (8- by 17-ft) caterpillar-type gates, a stilling basin, and an outlet channel. Just past the left abutment is an unrestricted saddle spillway with a crest elevation of 890 ft above msl.

During a routine inspection, potentially serious embankment underseepage was discovered. Boils and springs had always been active during times of pool storage. In July 1969, during a high-pool event, seepage increased to the point that inspectors became concerned about the stability of the embankment under higher pools. Subsequent studies were initiated, and as a result, 14 relief wells, 2 collector drains, and a toe trench were installed by 1975. After the pool reached el 857.7 in March 1975, the consensus was that the relief well system was not adequate. Consequently, seven additional wells and four additional collector drains were installed in 1976.

A component of the Dam Operation Management Policy (DOMP) is that personnel prepare inundation maps that identify areas that would be affected in the event of a flood. The maps for Mohawk Dam, completed in November 1984, were prepared for two conditions: spillway design flood routing without dam failure and spillway design flood routing with dam failure. The investigation for the mapping indicated that the spillway at Mohawk Dam was inadequate and needed several remedial treatments.

In 1986, construction was begun at Mohawk Dam to correct the spillway deficiency. When the construction was completed in 1988, the crest of the dam had been raised 1.4 m (4.5 ft) to el 914.5, a parapet wall had been built along the crest to provide the required freeboard, an upstream stability berm had been added, the downstream filter blanket had been raised, and the spillway had been widened.

The procedure for raising the crest of the dam was to place a layer of random fill on the upstream face of the embankment and then cover it with a layer of random rock fill. The original upstream slope varied from 2 to 3:1. The rock fill and random rock blanket provide a 4:1 stability berm to el 840 where a 15.5-m- (50-ft-) wide bench was constructed. The 4:1 slope continues above the bench to el 891 where it transitions to 2.5:1 and continues from there to the crest. Because space near the intake structure was limited, it was not possible to maintain the 4:1 stability berm cross section. In this area, select fill was placed on a 2:1 slope to el 900 before transitioning to a 2.5:1 slope from that point onward to the crest. The crest of the dam was covered with impervious fill. After the embankment was raised, a 0.9-m- (3-ft-) high concrete parapet wall was installed to provide the minimum required freeboard (Figure 56).

The spillway was widened from 195 to 200 m (640 to 657 ft) to improve entrance conditions and to provide a suitable foundation for the newly added spillway approach sidewalls. A monolith was added to each end of the curved concrete weir that protects the spillway crest in the event of spillway flow (Figure 57). Concrete hang-on walls for the spillway approach were constructed at the contacts between the weir and the excavated spillway sidewalls. A one-row grout curtain, 9 m (30 ft) deep, 3-m (10-ft) centers was also placed along the line of the concrete weir. Additionally, the concrete hang-on walls and the existing weir monoliths were anchored into the rock. No. 8 reinforcing bars were grouted into drill holes spaced on 3-m (10-ft) centers (Figure 58). The anchors were then posttensioned to 149 kN (33.5 kips).



Figure 56. Construction of a parapet wall on the upstream crest of Mohawk Dam (from U.S. Army Engineer District, Huntington 1990b)

An apron keyed into the rock was added to the existing weir cross section. Reinforcing bars anchored into the existing weir were used to secure the apron. Only the top lift of concrete for the apron was reinforced (Figure 59). The surfaces was screeded smooth (Figure 60).

Also, an additional 0.9 m (3 ft) of fill was placed on the filter blanket that was constructed at the downstream right terrace in 1982. The cost of the entire remedial treatment was \$8,894,549.12.

The Fifth Periodic Inspection (USAED, Huntington 1990b) reported the concrete in the new apron and sidewalls, outlet works, stilling basin, intake structure, and parapet walls to be in good to excellent condition. The stilling basin was not dewatered for this inspection, but all visible areas were in good condition. A few weep holes needed cleaning and the bulkhead needed painting; otherwise, no repair work or remediation was required.



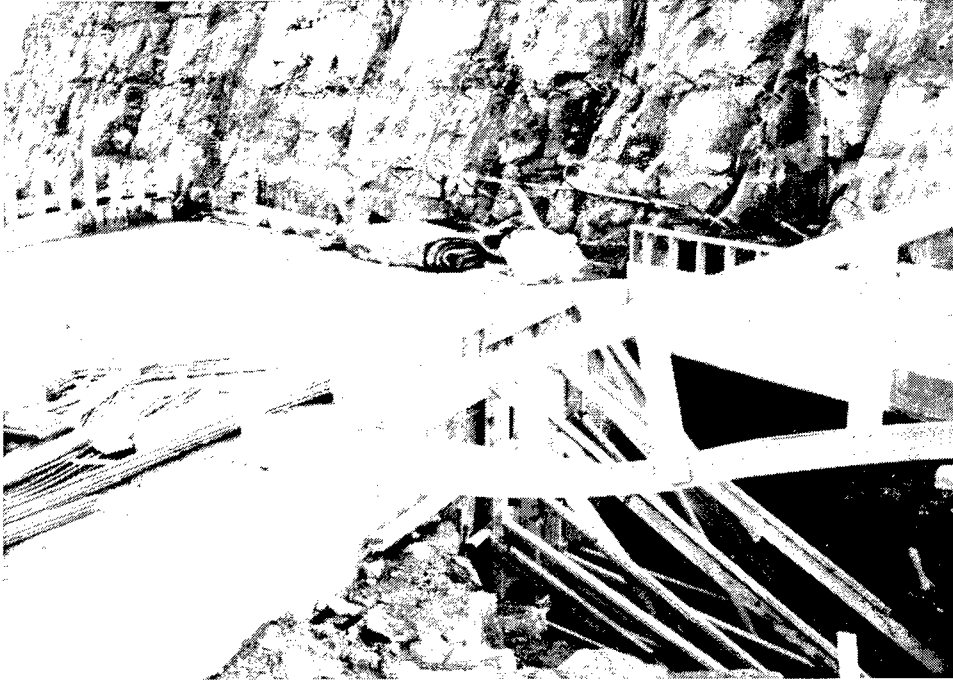

Figure 57. Forming for construction of additional monolith on the right side of the spillway, Mohawk Dam (from U.S. Army Engineer District, Huntington 1990b)

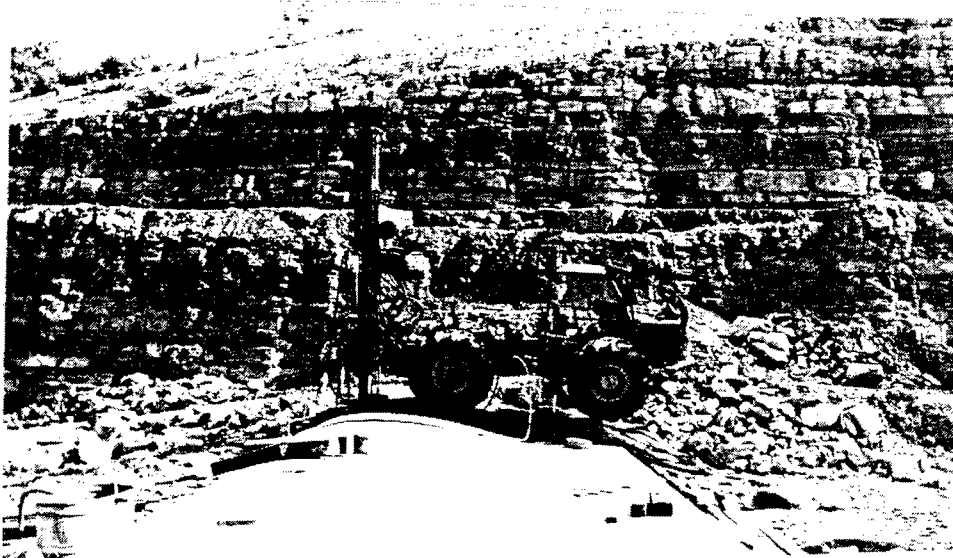

Figure 58. Holes drilled for installation of posttensioning anchors on spillway crest, Mohawk Dam (from U.S. Army Engineer District, Huntington 1990b)

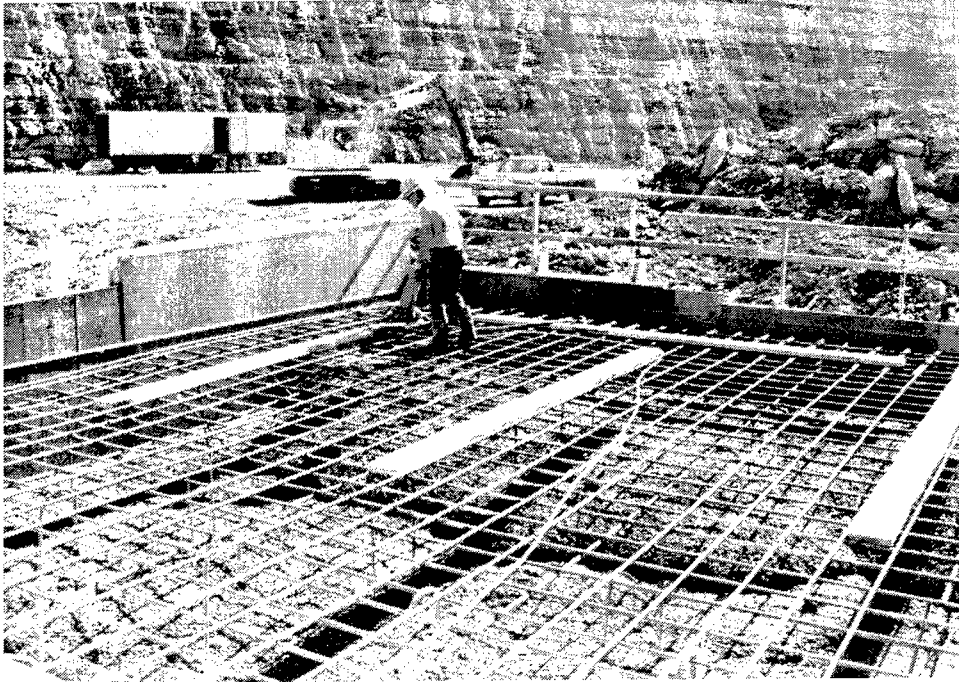

Figure 59. Forming and reinforcing for the top lift of concrete for the apron, Mowhak Dam (from U.S. Army Engineer District, Huntington 1990b)



Figure 60. Placing and finishing concrete for the top of the spillway apron, Mohawk Dam (from U.S. Army Engineer District, Huntington 1990b)

## R. D. Bailey Dam

R. D. Bailey Dam is located in Mingo and Wyoming Counties, West Virginia, on the Guyandotte River. The dam, which was completed in 1979, is a 94.5-m- (310-ft-) high rolled, random rock-fill structure with a reinforced concrete face. The outlet works, located in the left abutment, consists of an inlet channel, a 52.7-m- (173-ft-) high reinforced concrete intake structure with two 1.8- by 3.7-m (6- by 12-ft) sluices controlled by hydraulically operated slide gates for flood-control operation and five 3- by 2.4-m (10- by 8-ft) intake gates at three elevations, which discharge into an 1- by 3-m (3.3- by 10-ft) sluice for selective withdrawal. Discharge from the intake structure flows into an 5.5-m- (18-ft-) diam, 549-m- (1,800-ft-) long, circular, concrete-lined tunnel. The tunnel, in turn, discharges into a conventional stilling basin. This case history is based on findings of the Tenth Period Inspection Report (USAED, Huntington 1993).

The stilling basin was dewatered in May 1977 during the final inspection of the outlet works. At that time, some damage to the baffles had occurred. During this inspection, erosional damage to both sides of the outlet channel was noted. No action was taken. The basin was again dewatered in 1980. Inspectors found no stones in the basin, but the damage to the baffles had worsened, and they noted an area of erosion downstream of the stilling basin. A study to determine the cause of the erosion and lack of stilling action in the basin was conducted. The conclusion was that the basin had been inadequately designed. To correct the design flaw, a concrete dam was constructed in the outlet channel to increase stilling action by raising the tailwater. The stilling baffles were rebuilt, and an anchored concrete slab was placed in the scour hole. A new 7.3-m- (24-ft-) wide bridge with walkway and parapet was placed on top of the new dam. The left side of the outlet channel was repaired with a semi-gravity, concrete hang-on wall, and stones were placed on both sides of the outlet channel to protect the slopes from erosion. Construction was completed in 1983. Dewatering and inspection in July 1993 revealed the general condition of the stilling basin to be very good. No chipping, spalling, or other damage was noted (Figure 61).

Moisture has been a problem in the intake structure since the dam became operable. During the first inspection in 1979, a number of cracks in the intake structure were noted in the walls and service platform. These cracks were not considered structurally harmful, but most did exhibit leakage when the pool was raised. Excess water (due to leakage) and high humidity levels caused problems with electrical equipment and created a safety hazard to those working with and around the equipment. Also, the excess moisture caused the paint on equipment to peel. In November 1984, a gutter was installed to channel seepage and condensation from the walls to the floor drain on the premise that if the gutter had solved or improved the problem, sealing the cracks would not have been necessary.

Because the cracks had to be sealed from the outside, necessitating underwater work or drawdown of the lake, a decision was made to seal one crack in

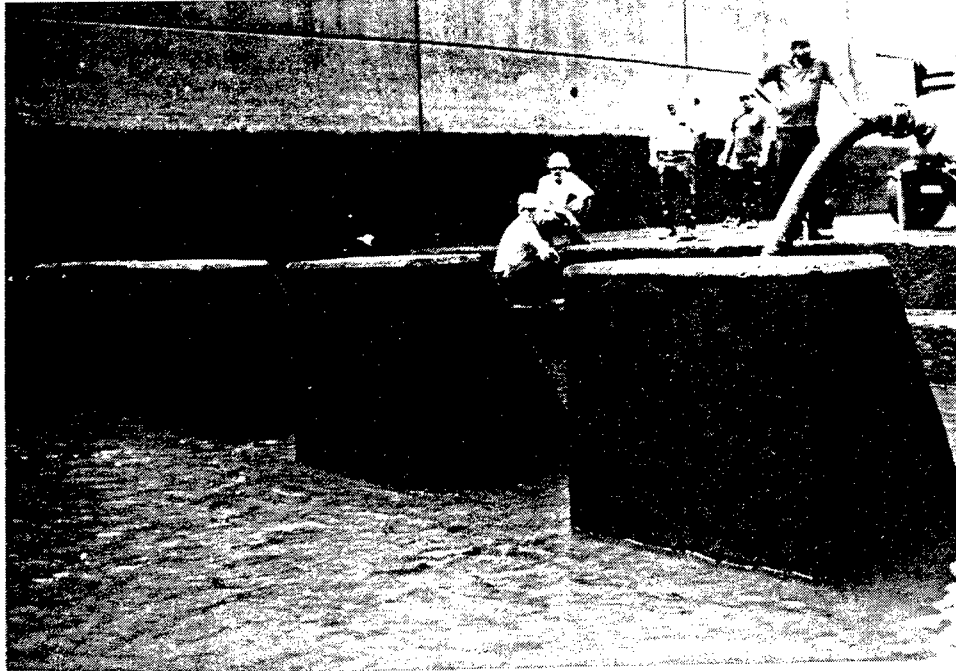

Figure 61. Upstream face and baffles in dewatered stilling basin, R. B. Bailey Dam (from U.S. Army Engineer District, Huntington 1993)

the lower portion of the intake structure as a test of the repair method; if that repair was successful, the other cracks would be similarly repaired. The crack was sealed with an epoxy grout heated to approximately 38 °C (100 °F) and injected under pressure to about 0.7 MPa (100 psi). The work, completed in March 1987, was only partially successful. The relative coldness of the concrete, coupled with the narrow crack width and long crack path apparently caused the sealing to be incomplete.

In 1989, a plan to cover the outside of the intake structure (Figure 62) with an adhesive-mounted rubber membrane similar to roofing-type materials was considered. However, because of concern for loss of fish and other aquatic life and the impact upon recreational activities resulting from the proposed drawdown, a decision was made to make another attempt at sealing the cracks, this time from the inside.

In January 1990, plans and specifications for sealing the cracks from inside the intake structure were completed, and work was scheduled to begin in the spring of 1990. However, the specified materials were determined to be hazardous because of their low flashpoint. A recommendation was made that safer materials be used. Specifications were rewritten to use a polyurethane grout with a high flashpoint. The cracks were injected in 1991 with a single-component, moisture-reactive urethane liquid, which, upon curing, expands and forms a water-impermeable, elastomeric-polyurethane foam. The cracks injected ran vertically in a wall 4 m (3 ft) thick and then continued horizontally in a floor slab 2.4 m (8 ft) thick. The maximum external hydrostatic head on any crack

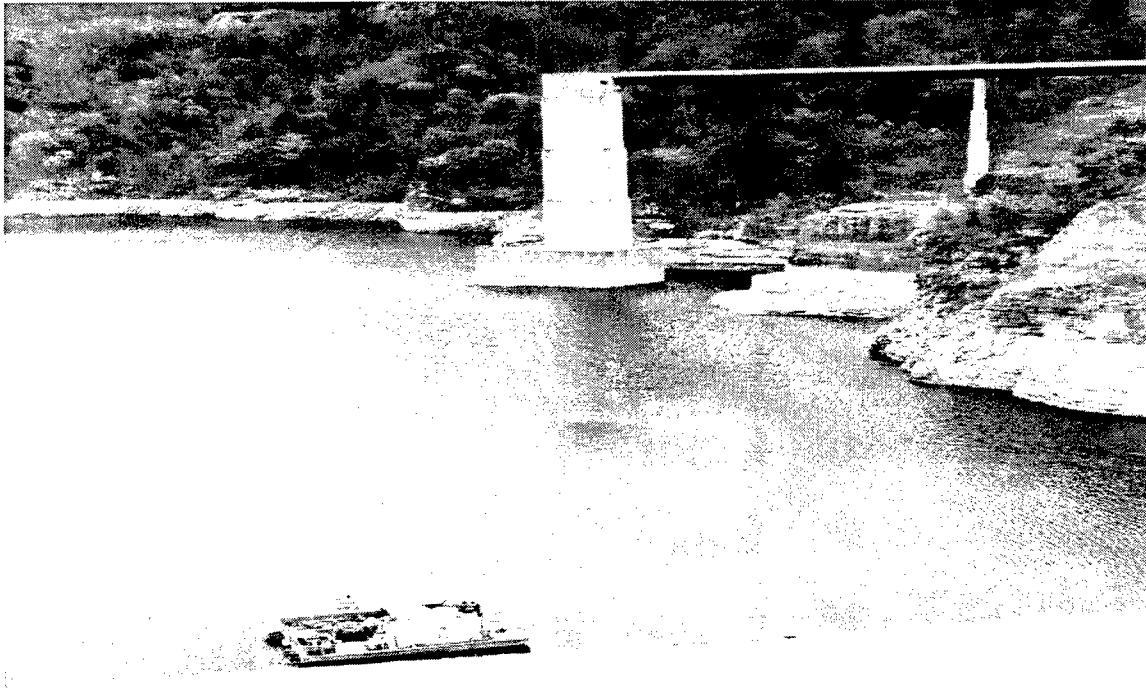

Figure 62. Intake structure and access bridge, R. D. Bailey Dam

during sealing was 34 m (12 ft). The injection was done by contract. Although the sealing appeared to be successful at first, the 1993 inspection revealed continued problems with the elevator, other electrical items, and metal components caused by leakage through cracks and condensation. A decision to try to solve the moisture problem by dehumidification was made, and a request for bids for providing and installing a complete dehumidifier system was issued in November 1993. This decision was based on the success of this method at other district project intake structures with similar moisture problems.

Cracking in the concrete face of the dam and toe blocks has been another source of seepage. When divers inspected the concrete face in March and April 1981, they found several seepage entrance areas, but most were considered to be minor. The most significant area found was where lanes 16 and 17 intersected with the toe block. There were broken slab sections, and settlement of about 152 mm (6 in.) was noted. A task force that investigated the problem concluded the distressed area was an isolated occurrence and there was no cause for concern for either rapid or progressive failure. The area was repaired in December 1991. Silty sand was used to choke underlying materials and minimize seepage. The 1993 inspection team found areas of spalling on the concrete face and toe block and recommended these areas be removed and that exposed reinforcing steel be painted to prevent further deterioration. In 1993, the toe block cracking was remapped and all joints on the face were sounded for drumminess. The toe block cracking showed little change. Some previously

noted drummy areas are now showing cracking at the approximate boundaries of the drummy/nondrummy areas. The face was not totally remapped, but during the sounding along the joints, changes in cracking associated with drummy areas were noted.

In 1993, four of the five selective withdrawal gates were repaired by inspection divers and are now in operation again. The divers drilled through each gate stem and bolted it to prevent it from separating from the gate. The cavitation/erosion at the bottoms of the service gates had not been repaired as recommended by the Eighth Periodic Inspection team. The Tenth Periodic Inspection team concurred in that recommendation but noted that the cavitation had not worsened significantly since the last inspection.

The strong motion indicators installed in 1983 and 1985 were replaced with updated equipment in October 1991. There was no indication that increased instrumentation was needed.

The embankment generally appears to be in good condition. Recommendations were made that several areas on the downstream right and left and upstream right abutments be cleared of undergrowth. It was also recommended that vegetation on the downstream slope be sprayed and that the outlet channel downstream of the structure be cleared.

## **Sutton Dam**

Sutton Dam is located on the Elk River near Sutton, WV. The dam, a 70-m- (230-ft-) high concrete gravity structure with five low-level sluices (Figure 63), was constructed between 1949 and 1961 to provide flood control, general recreation, fish and wildlife enhancement, and water supply. Construction, operation, and maintenance of the structure adversely affected the aquatic environment downstream of the dam. The problems were primarily caused by depressed water temperatures and increased turbidity resulting from the outflow of water from the lowest stratum of the reservoir. Moreover, winter drawdown and seasonal pool elevations interfered with lake fishery and with water recreation in general (Barnes 1992b).

The obvious solution to the problem of downstream water temperature and turbidity was to relocate the intake to permit the outflow of warmer, less turbid water from the highest stratum of the reservoir. Making this change required the construction of a high-level intake connected to one of the sluices of the dam (Barnes 1982b). The shape of the structure was determined by model tests at WES.

A 30.5-m- (100-ft-) high, 4.9-m- (16-ft-) radius, semicircular, high-level steel intake (Figure 64) was designed to be placed over the center sluice on the upstream face of the dam. Construction began in June 1979. The work had to be performed in winter, when the pool was near minimum. Even at low level, there was a high probability that a cofferdam would be overtopped frequently;

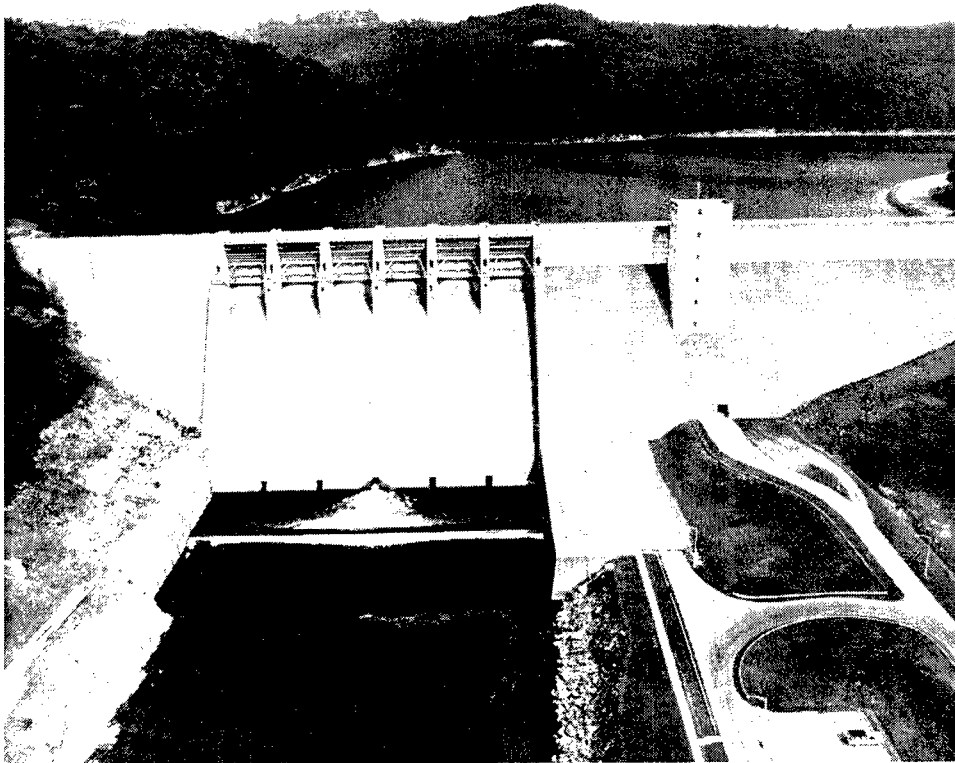

Figure 63. Aerial view of Sutton Dam (from Barnes 1982b)

therefore, nearly half the structure was installed by divers using a variety of underwater techniques.

The foundation and bottom of the structure were formed of concrete, tremied into place. The 136-mg (150-ton) structure of plate-and-rib design was fabricated in three pieces and attached to the face of the dam with high-strength rock bolts (Figure 65). A circumferential concrete fillet was added at the invert in the bottom of the structure to improve flow conditions in accordance with model testing performed at WES. An inlet-with-bulkhead was installed below the top of the structure to permit the passage of water during low lake levels. Finally, the top of the structure was capped with concrete to a depth of 6 m (20 ft). The concrete cap would improve flow, provide support for the trashrack, and provide an aesthetically “finished” appearance (Barnes 1982b).

The structure was completed in May 1980 at a final construction cost of \$1,960,863. Together with the modification of seasonal and winter pool elevations, the structure (a) has effectively restored acceptable downstream temperature and turbidity levels, (b) has improved lake conditions significantly, and (c) did not interfere with the project’s primary functions of flood control and low-flow augmentation (Barnes 1982b).

Because of the lake elevation, the inside of the high-level intake structure was not inspected during the fourth or fifth periodic inspections (USAED,

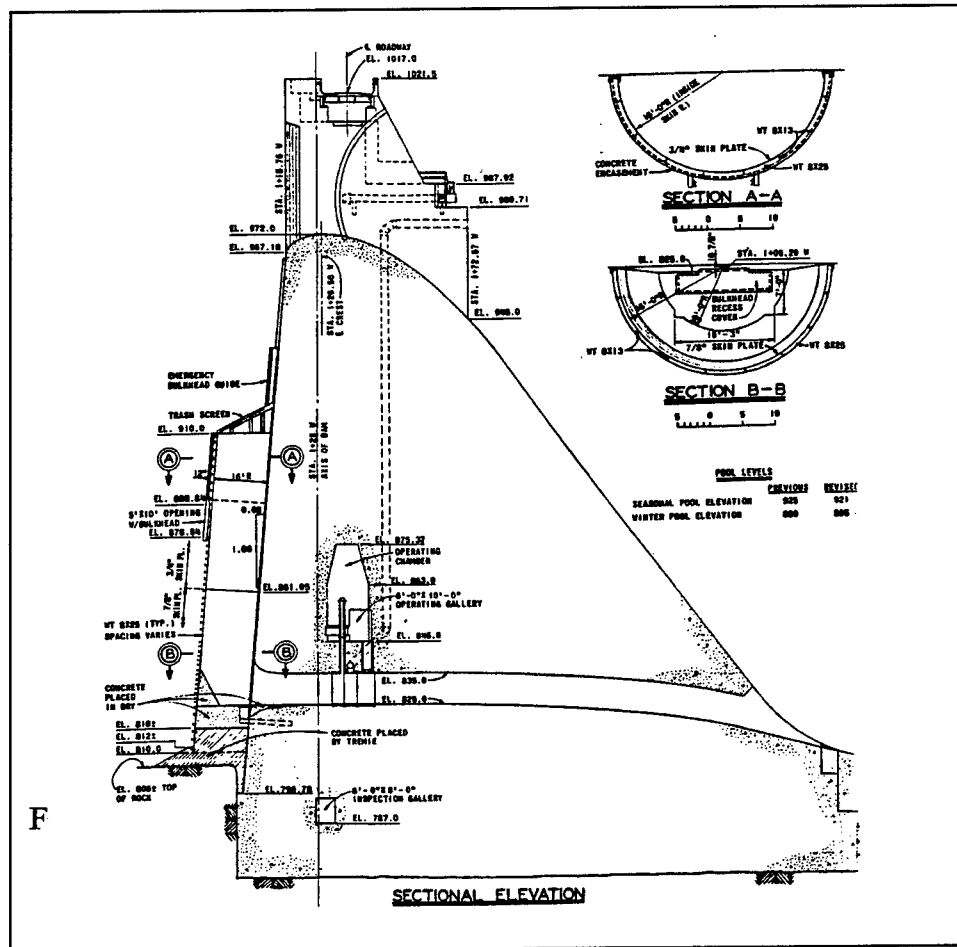

Figure 64. General design details of high-level intake at Sutton Dam (from Barnes 1982b)

Huntington 1984 and 1989). However, all external concrete components were reported to be in good condition during both inspections.

### Tom Jenkins Dam

Tom Jenkins Dam is located on the east branch of Sunday Creek near Glouster, OH. Completed in 1950, the dam was constructed on Burr Oak Lake to provide flood control, recreation, and water supply. The rolled homogenous earth-fill embankment is 25.6 m (84 ft) high and has a 288-m- (944-ft-) long crest. The intake structure has three 1- by 2-m (3-1/2- by 7-ft) gate sluices with a discharge capacity of 39 cms (1,380 cfs) at water supply level. The uncontrolled, open-cut spillway crest is located at el 740. A blanket drain controls seepage in the downstream third of the embankment.

In the mid-1960's, a toe-drain system was installed at the downstream area of the dam to drain seepage from the blanket drain. By 1975, however, very wet, spongy areas were noted at the toe of the dam. These wet areas were present,



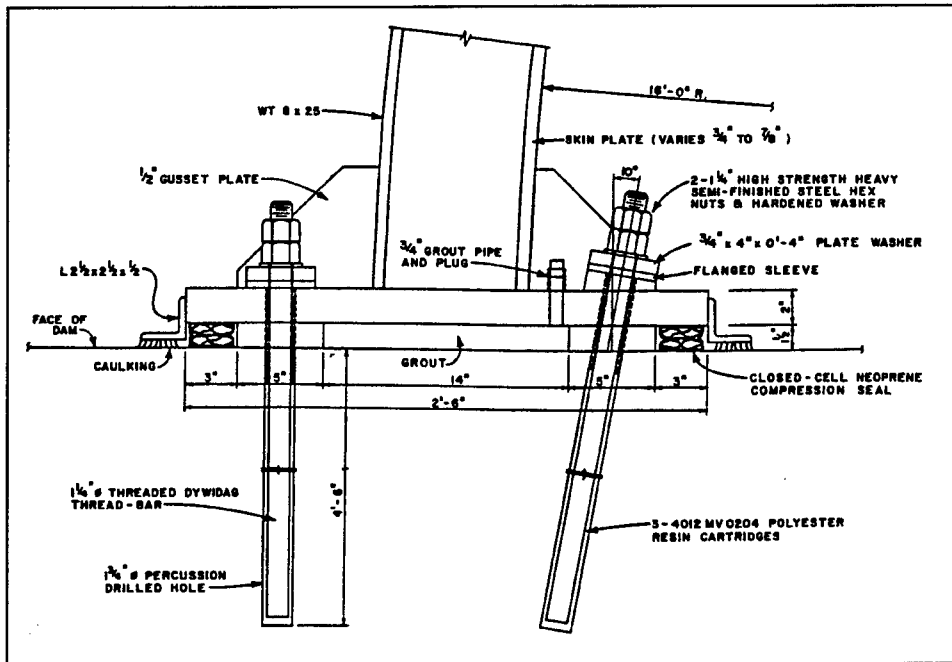

Figure 65. Connection detail for intake at Sutton Dam (from Barnes 1982b)

even in very dry weather. The moisture may have been caused by drainage from the horizontal blanket. It was concluded that the toe drain system was insufficient and that a more functional drain was warranted. At the time of the Fifth Periodic Inspection (USAED, Huntington 1990c), the area was still wet. Again, the recommendation was that the toe-drain system be repaired or replaced.

The components of the stilling basin have been in good condition throughout the history of the project with the exception of the concrete in the training walls. Seepage water flowing over the face of the concrete walls combined with freezing and thawing conditions caused severe deterioration of the concrete. The walls were patched in 1968, but this repair did not hold. More extensive repairs were undertaken in 1975. All deteriorated concrete was removed, and 0.3-m- (1-ft-) thick reinforced concrete was placed on the surface of the walls. The reinforcing consisted of 19-mm (3/4-in.) steel bars placed on 305-mm (12-in.) centers. The 76-mm- (3-in.-) diam weep holes in the existing walls were cleaned and extended through the new reinforced concrete surface. A 1,067-mm (42-in.) parapet wall was installed around the stilling basin to keep water from flowing over the stilling basin and training walls. The repairs were completed in 1976 at a cost of \$75,000. The walls have been in good condition since these repairs were made.

The stilling basin was dewatered for the Fifth Periodic Inspection (Figure 66). All components were in satisfactory condition. A depression from 25 to 51 mm (1 to 2 in.) was found in the center of the basin floor, but no remedial action was planned. Monolith joints in the training walls had slight damage, spalling, and popouts (Figure 67) but none that required repairing.

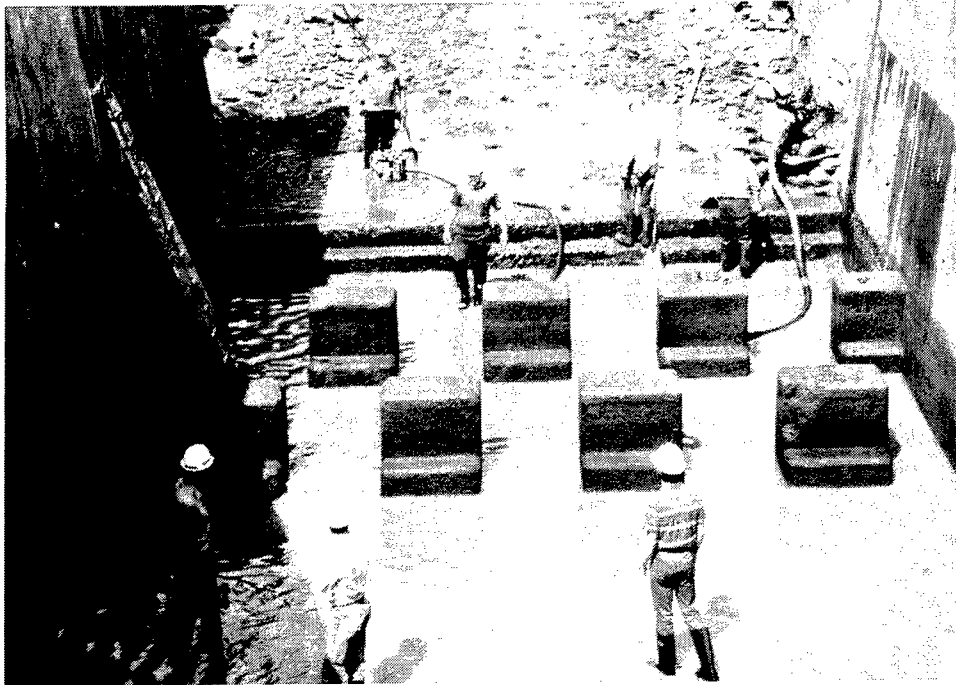

Figure 66. Stilling basin dewatered for fifth periodic inspection, Tom Jenkins Dam (from U.S. Army Engineer District, Huntington 1990c)

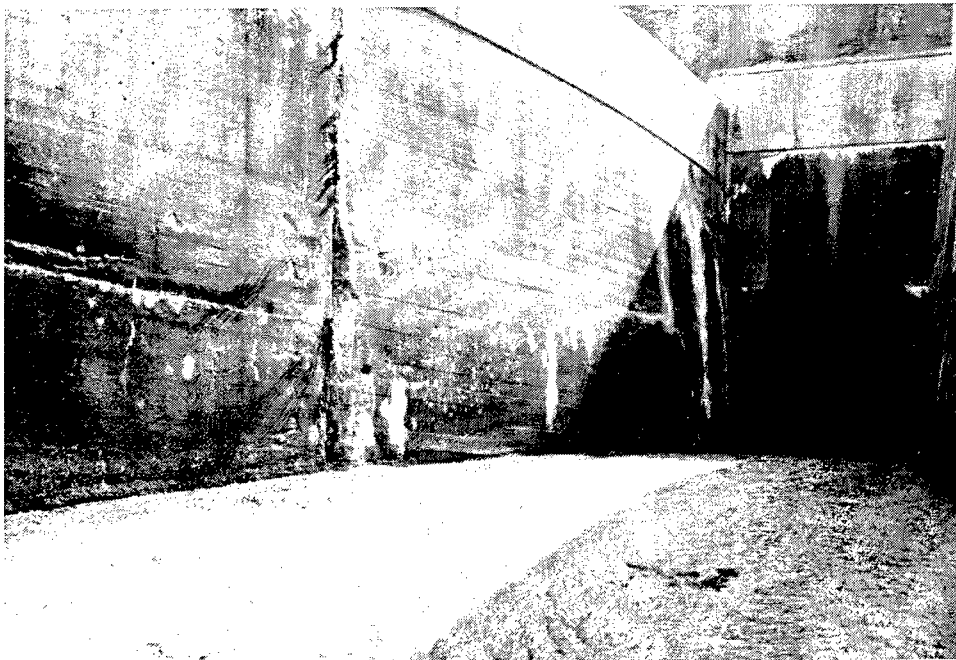

Figure 67. Spalled area in monolith joint on right basin wall, Tom Jenkins Dam (from U.S. Army Engineer District, Huntington 1990c)

## Nashville District

### Center Hill Dam

Center Hill Dam is located in DeKalb County, Tennessee, on the Caney Fork River about 80 km (50 miles) east of Nashville. Construction on the dam began in March 1942, but because of the World War II, it was not completed until November 1948. The project provides flood control, hydroelectric power, and recreational opportunities. Constructed across a valley, the 76.2-m- (250-ft-) high dam consists of a 421-m (1,382-ft) concrete gravity-type section on the right side of the valley and a 23.7-m (778-ft) earth-fill embankment on the left. The concrete gravity section has right and left bank nonoverflow sections, a spillway, and a powerhouse intake (Figure 68). This case history is a summary of a report by Hugenberg (1987).

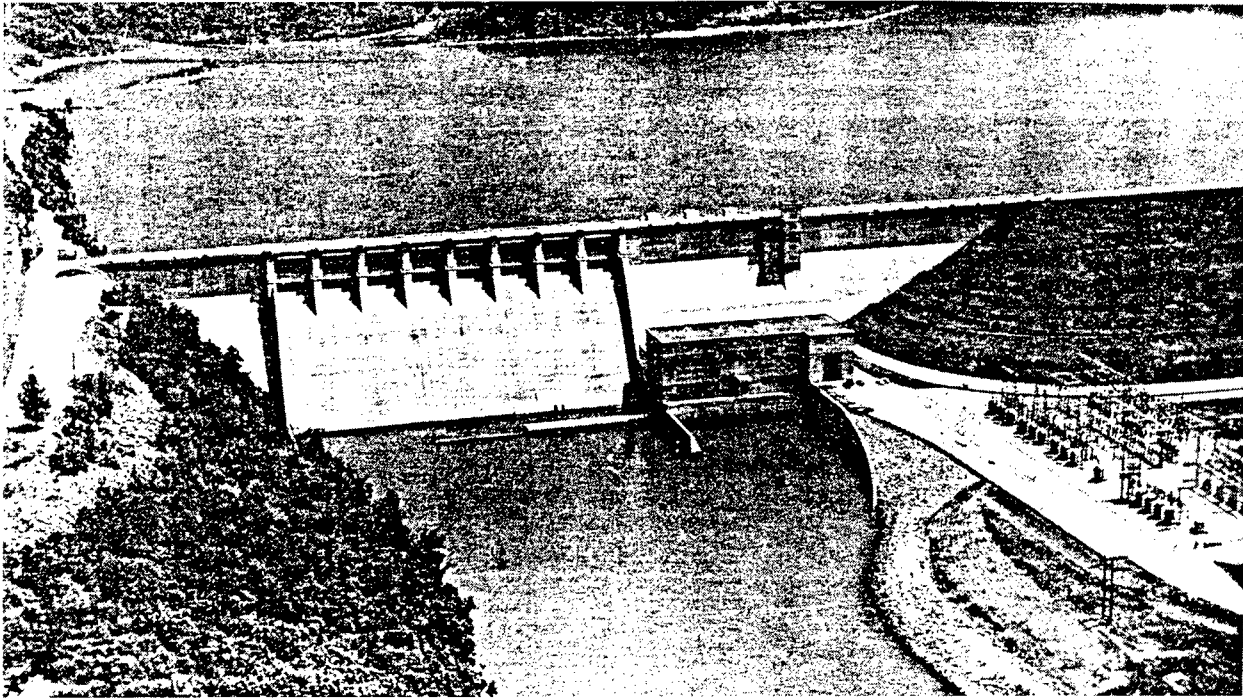

Figure 68. Upstream view of Center Hill Dam (from Hugenberg 1987)

Aggregate used for the concrete was taken from an onsite quarry in the Ordovician Cannon Formation. This quarry was evaluated during the initial stages of the project, but limited information is available for reconstructing the evaluation process. In making the concrete, guidelines published in the leading engineering journals were followed; portland cement complying with Federal Specification SS-C-206a was used, but no limitation was placed on the alkali content of the cement. Until 1947, all concrete used in the structure was nonair-entrained.

The concrete structure operated as intended without any deficiencies of engineering significance until about 1967. A detailed engineering inspection in August 1967 found several horizontal lift joints to be leaking excessively. Two of these joints were located near the center of the spillway near crest elevation. Concrete cores were taken through the leaking joints. The conclusion reached by this investigation was that the cause of the leakage was poor bond resulting from deficient construction. The joints were reinforced with anchors/bars to assure monolithic action of the lifts.

After a 1974 inspection of the bridge over the spillway, several of the bridge supports on the right end of the spillway were reset because they were raised, causing the end of the spillway to tilt towards the center. No detailed investigation into the cause of the displacement was conducted.

A 1983 inspection of the structure revealed additional problems in the spillway section. The expansion joints and bridge seats for the first two spans on both ends of the spillway showed excessive movement toward the center of the spillway. Also, Gates 8 and 1 bound when they were raised short distances. The torque shaft for tainter Gate 8 on the left side of the spillway had to be shortened by 32-mm (1-1/4 in). Electrical conduits beneath the roadway had also buckled. A decision was made to identify the cause of structural distress so appropriate measures could be taken to remedy them.

In the late summer of 1983, cores were taken from the dam, galleries, adits, powerhouse, spillway piers, and spray walls and were sent to WES for petrographic examination and testing. The mineralogical composition of most of the rock was calcite with some dolomite and quartz and some clays and feldspars. Some of the rock types were identified as potentially reactive. The concrete cores contained many aggregate particles with reaction rims left in relief when the more soluble carbonate particles were acid etched. Five small cores were taken from aggregate particles within the larger concrete cores and tested for expansion according to ASTM C 586-69 (1995d). Test results indicated a potential for alkali-carbonate rock reaction but were not considered to be conclusive.

In 1984, rock samples from the onsite quarry that had been used for aggregate production in construction of the dam were tested. These tests, along with the tests on the concrete cores and petrographic examinations led to the conclusion that some potentially reactive aggregates were used in the concrete.

In 1967, an extensive crack survey revealed only horizontal lift joint leakage. In 1984, considerable horizontal and diagonal cracking on the upstream and downstream faces of the monoliths at the ends of the spillway indicated that compression was taking place along the horizontal axis of the dam, tending to force the upper portion of the monoliths into the spillway opening.

To monitor further movement in the structure, monuments were set at the top of each monolith and references to permanent monuments in both abutments. The monuments were monitored at periodic intervals with high-order precision

equipment. The data collected showed that the entire structure had traveled upstream and that individual monolith elevations had increased. Monoliths 7 and 15 had shifted into the spillway opening, while Monoliths 2 and 3 had shifted toward the right abutment; joints 6-7 and 15-16 were opening. Inspection in April 1984 indicated that all of the bridge expansion joints were closed and the fixed supports were rocked toward the center of the spillway (Figure 69).

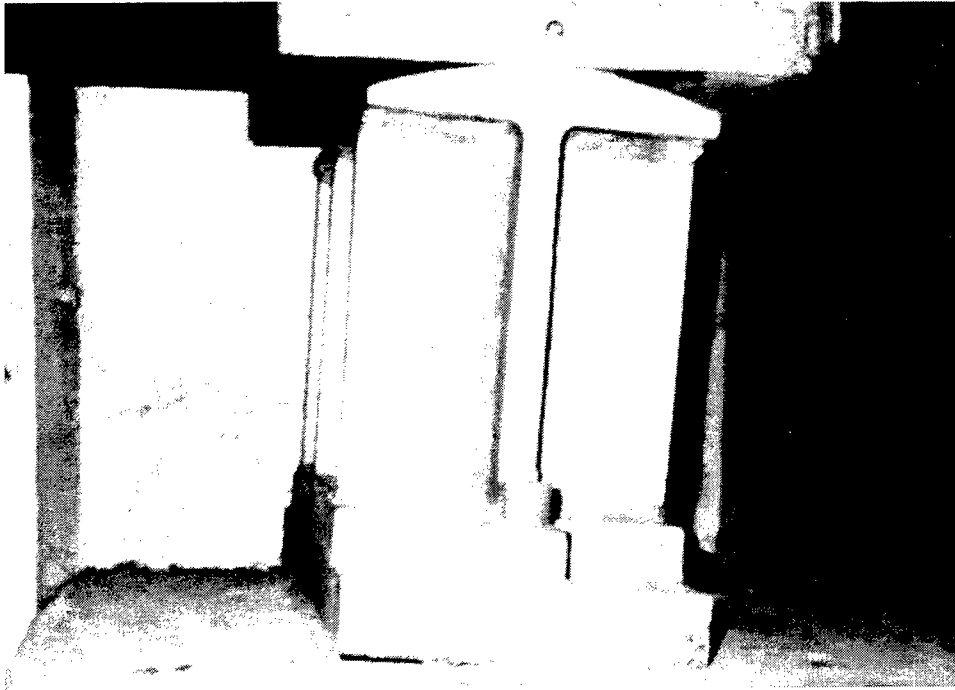

Figure 69. Fixed bridge support leaning toward the center of the spillway at Center Hill Dam (from Hugenberg 1987)

In the summer of 1985, the bridge spans were shortened by cutting the concrete deck (Figure 70) and steel girders. The supports and expansion joints were reset. Gates 1 and 8 were shortened, and the embedded gate seals in Monoliths 7 and 15 were built out to vertical so that the gates were again functional.

There was no proof that shortening the bridge spans and spillway gates was more than a short-term solution to operational deficiencies and that the structure might not continue to grow.

## **Pittsburgh District**

### **Loyalhanna Dam**

Loyalhanna Dam is located on Loyalhanna Creek in Westmoreland County, Pennsylvania. The dam was constructed by the Great Lakes Dredge and Dock Company in 1942 at a cost of \$1,700,000. This concrete gravity-type structure

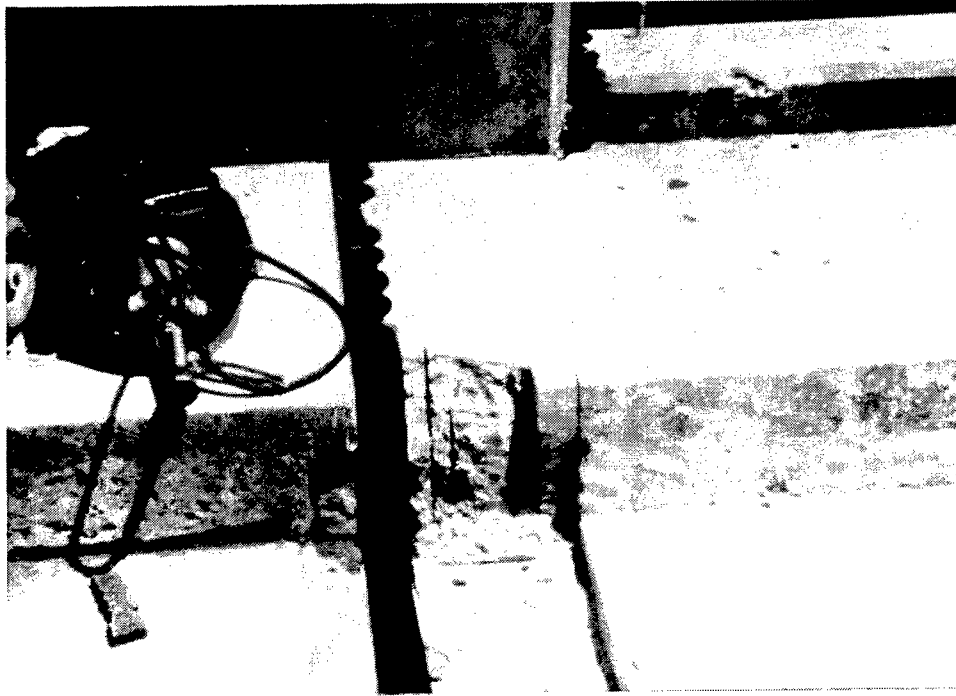

Figure 70. Sawcutting and coring to shorten concrete bridge deck at Center Hill Dam (from Hugenberg 1987)

has a rolled earth-fill abutment on its left side and a five-gate spillway section; the total length of the structure is 292.6 m (960 ft); its elevation is 300 m (983 ft). The outlet works is regulated by four hydraulically operated gates. The stepped stilling basin stretches 35.5 m (116.5 ft) downstream of the dam, and its training walls extend 3 m (10 ft) past that point.

Shortly after operation of the structure began in 1946, the steel service gates in the outlet works were replaced with CRD clad gates. Micarta seals were installed on the gate leaves, and CRS seals were installed on the gate frames. Cost of these modifications was \$29,000. The deterioration of the steel gates was attributed to acid water. The bottom section of service gate 2 was reconstructed in 1967 and filled with Igas joint filler at a cost of \$6,500. The gates were reported to be in good condition.

All four of the emergency gates in the outlet work have been renovated and the bottom section of the gates reconstructed. The repair history is as follows:

| Date | Gate             | Cost     |
|------|------------------|----------|
| 1970 | Emergency Gate 2 | \$16,000 |
| 1972 | Emergency Gate 3 | 9,500    |
| 1973 | Emergency Gate 4 | 11,000   |
| 1974 | Emergency Gate 1 | 11,000   |

Concrete damage at the top of the dam was repaired in 1986-87. The dam top was marked with many areas of spalling, leaching, and cracking that varied in size and location. The repair work consisted of the placement of a section of new 102-mm (4-in.) overlay near the right abutment, selective concrete patching of the dam deck and parapet walls, and removal of the spillway post and replacement similar to that of the parapet wall dimensions.

Selective concrete repairs to the spillway crest were done in conjunction with repairs to the top of the dam. These repairs consisted of replacement of concrete for a depth of 102 mm (4 in.). No. 4 dowels and wire mesh were used in the replacement concrete. Minor cracking is now present in the repaired areas of Monoliths 9 to 11.

In 1988, eroded areas in the deflector floor plates in sluices 1, 3, and 4 and downstream of the service gate in sluice 4 were repaired. Work included placement of an epoxy resin compound in all sluices at the concrete floor to deflector (tetrahedral) plate transition to alleviate any undercutting, placement of the same epoxy resin compound in miscellaneous other areas, and enlargement of the air vent gratings downstream of all service gates.

The Fifth Periodic Inspection (USAED, Pittsburgh 1990a) revealed minor cracking in the repairs to the parapet walls and some vertical cracking in the parapet (Figure 71). However, no plans were made to repair these areas, as the concrete was considered to be, generally, in good condition.



Figure 71. Minor cracking below and to the right of selected repair on parapet wall, Loyalhanna Dam (from U.S. Army Engineer District, Pittsburgh 1990a)

## Point Marion Lock and Dam

Point Marion Lock and Dam are located on the Monongahela River, approximately 1.6 km (1 mile) upstream from Point Marion, Pennsylvania. The original lock and fixed-crest dam were constructed by Government forces in 1923-1926. The dam was reconstructed in 1958-1959 to provide a movable crest and to raise the upper pool by 1.2 m (4 ft). This modification was done as part of a series of projects to provide a minimum of 2.7-m (9-ft) navigable depth in the upper Monongahela River. The lock is located on the left bank and consists of a single 17- by 110-m (56- by 360-ft) chamber with a normal lift of 5.8 m (19 ft). The lock walls and gate sills are unreinforced concrete gravity sections founded on bedrock. The top of wall elevation is el 803. The dam piers, constructed of reinforced concrete, are founded on and anchored into bedrock. The dam consists of six bays with nonoverflow movable trunnion gates, each 21.3 m (70 ft) long by 2.6 m (8.5 ft) high, and an 18.9-m- (62-ft-) long fixed weir with a crest elevation of 796.7 and a total length of 170 m (557 ft). (The 171-m (560-ft) weir was shortened 0.9 m (3 ft) and the crest raised 0.3 m (1 ft) during 1988 dam rehabilitation). A concrete cutoff wall and continuous concrete baffle wall (end sill) were constructed in 1959 at the downstream end of the original dam apron to underpin the apron in areas where it was undermined from erosion.

The dam was rehabilitated in 1988 primarily to address stability concerns that the piers, dam sill, and abutment had potential for sliding. Work done under this contract included anchoring the dam piers and dam gate sill monoliths, anchoring and refacing the abutment, painting the service bridge, and concrete repairs to the piers and spillway areas.

A Design Analysis Memorandum for Dam Rehabilitation was completed in February 1986 (USAED, Pittsburgh 1989a). This analysis found that concrete placed at the dam during the modification in 1958-59 was generally in good condition. The only problem area was below the bridge seats where cracking had occurred and was repaired in 1969 and 1972. Areas where original concrete remained exposed were in poor condition with cracks and spalling occurring frequently. Scouring in the area of the abutment and fixed weir appeared to be a recurring problem. The structural steel elements of the dam were in good condition, except for localized pitting on the upstream face of the tainter gates. Stability computations based on fairly conservative rock strength parameters showed that sliding of the piers, dam still, and abutments was a serious problem.

The abutment concrete was also noted in the Design Analysis Memorandum as showing signs of significant deterioration. Stability analyses showed that the abutment monoliths were deficient in meeting both rehabilitation overturning and sliding stability criteria.

The Design Analysis Memorandum was submitted for use as a basis for the preparation of plans and specifications. Subsequently, a construction contract was awarded to the Nicholson Construction Co. for rehabilitation of the dam. Work was accepted as completed on 31 December 1988 with an approximate final cost of \$2,592,000.00.



Work accomplished during the dam rehabilitation included:

- a. Anchoring the dam piers and dam gate sill monoliths. Two inclined rock anchors per pier were installed, one on each side. Four or five rock anchors per gate bay were installed. The anchors were designed to attain a minimum factor of safety against sliding of 2.0.
- b. Refacing and anchoring the abutment. A 0.9-m- (3-ft-) thick wall that extended the full height and length of the abutment was installed. This refacing was heavily reinforced to distribute the load of the rock anchors required for stabilization. Eighteen anchors were staggered at two levels to further distribute the load. New 152-mm- (6-in.-) thick concrete paving was placed behind the abutment wall.
- c. Routing and caulking cracks. Cracks in the concrete below the service bridge seats of Piers 1, 2, and 6 were routed and caulked. A maximum of 152.4 mm (6 in.) of concrete was removed and replaced on the upstream and downstream faces below the bridge pier seats of Piers 5 and 7.
- d. Repairing spillway faces. Repair of the sloped downstream spillway face of each bay consisted of the removal of a minimum 152 mm (6 in.) of concrete, resin-grouting no. 6 hooked dowels into the existing concrete with no. 3 bars on 305-mm (12-in.) centers; and then shotcreting the repair area to its original shape; a downstream bulkhead was used to block lower pool; however, leakage and seepage through monolith joints reportedly made the shotcrete repairs difficult.
- e. Repainting the service bridge. The service bridge was sandblasted and painted with a urethane paint system instead of the original phenolic aluminum paint.
- f. Brush-off sandblasting the emergency bulkhead and hoist and applying three to five coats of vinyl paint.
- g. Performing selective lower spillway repairs in various areas. An attempt was made to use a fabricated caisson. However, a poor seal at the base of the caisson created numerous problems, preventing its use. Selective repairs of the spillway apron were then accomplished with an under-water placement of silica fume concrete. No concrete removal was done in these repairs. Also, no dowels or anchors were used.

The Fifth Periodic Inspection Report on the dam (USAED, Pittsburgh 1989a) noted the following conditions of the rehabilitation work.

- a. The spillway face repairs (shotcreting done in the 1988 dam rehabilitation) showed uneven lips between the old concrete and the new shotcrete. No action was required; however, it was noted that this lip could cause accelerated deterioration.

- b. The concrete in the piers was generally in good condition except for the following items. New cracks of a relatively minor nature continued to propagate from the bridge seats. This cracking appeared to be slightly worse at the upstream seats, which are closer to the concrete edges. Plans were to seal these new cracks and reseal the older cracks to help prevent additional damage.
- c. The new concrete refacing (done during the dam rehabilitation) on the upstream side, below the bridge seats, of piers 5 and 7 exhibited signs of minor cracking. A vertical crack, approximately 0.3 m (1 ft) long, had developed on the new upstream face of Pier 5, just below the right-side seat.
- d. The new concrete in the abutment wall was in good condition with minor cracking of the top surface of the downstream monolith noted.

The Seventh Periodic Inspection (USAED, Pittsburgh 1994) found that the condition of the dam and appurtenances was good (Figure 72). Fine, random cracks in refaced areas below the upstream bridge bearings on Piers 5 and 7 have developed; these will be visually monitored by staff and will be sealed as time and funding are available. Corrosion on the top flange of the upstream bridge girder has caused cracking and spalling in the overlying concrete deck slab. The recommendation for these areas is to clean and reseal the expansion joints to eliminate leakage that is causing the corrosion.

The concrete in gate bays and right-side fixed weir (Figure 73) exhibits deterioration in areas where concrete has been repaired. Divers reported numerous areas of erosion in the top of the concrete apron, but the baffle wall and end sill were in good condition. A section of the dam apron between Pier 1 and the old lock's riverwall was exposed during the inspection because the left-side fixed weir was being constructed. Previous areas of repair in this area are rough and were not struck flush with the surrounding concrete. It is recommended that in any future repair of stilling basin concrete the repair concrete be struck flush with the surrounding concrete.

An inspection of the dam in June 1994 by divers reported that the river bottom was as much as 1.2 m (4 ft) lower than the top of the dam's end sill. However, they found no undercutting of the cutoff wall or scour downstream of the end sill. Soundings conducted in July 1994 indicated no scour downstream of the dam. Based on previous Periodic Inspection Reports, diver inspections, and soundings, a decision was made not to provide scour protection; however, the area will be monitored, and additional soundings will be made during inspections.

Tainter gate structural members above water are generally well covered with a well bonded paint film. Debris, which has accumulated in the tops of the gates and in the interior structural members, has blocked some drain holes, causing water to pond in the gates. Water is also ponding in the gate arms near the trunnions where there are no drain holes. It is recommended that drain holes be



Figure 72. Downstream face of Point Marion Dam; end of old land wall is at right (from U.S. Army Engineer District, Pittsburgh 1994)

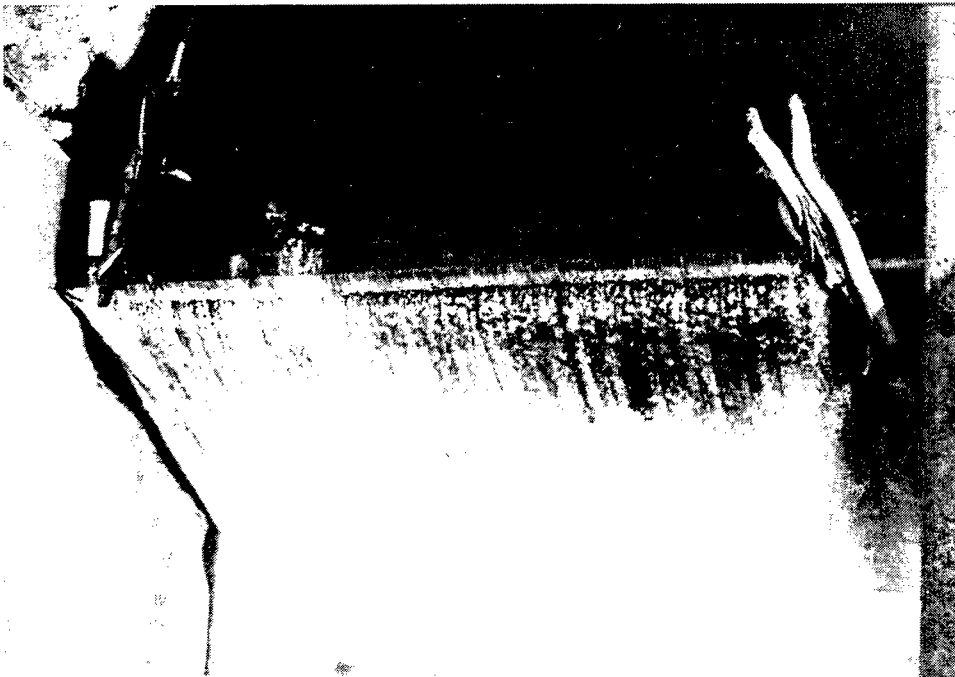

Figure 73. Right-side fixed weir section, Point Marion Lock and Dam (from U.S. Army Engineer District, Pittsburgh 1994)

evaluated before the gates are painted again, and consideration should be given to enlarging the holes.

Some leakage is occurring at gate side and bottom seals, but it is not enough to justify repairs. The trunnions and trunnion guide slots are operating without problems (Figure 74).

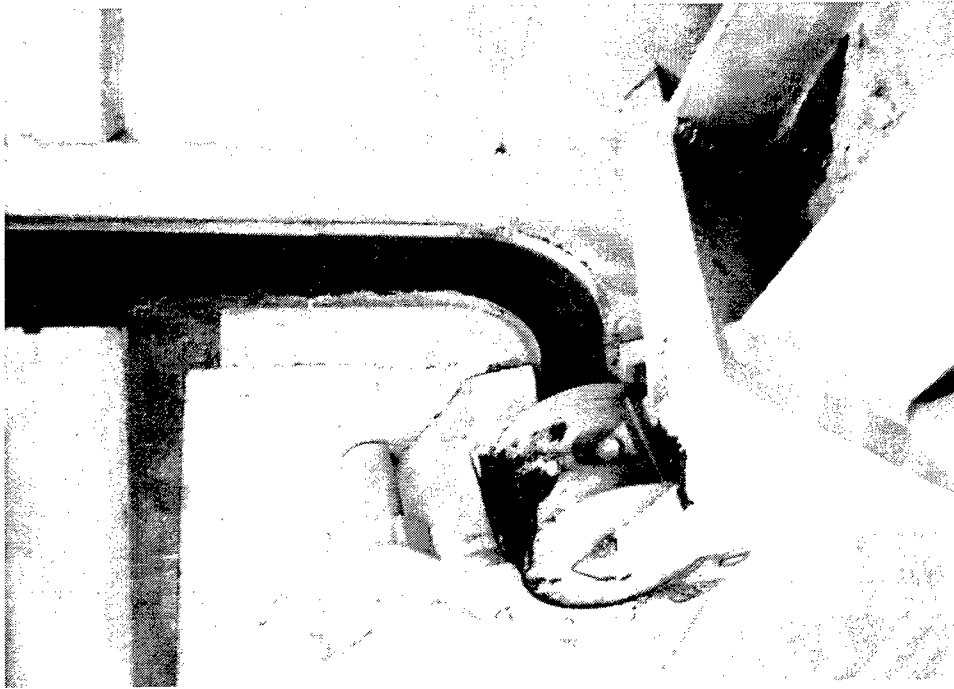

Figure 74. Gate arm and guide slot of tainter gate, Point Marion Lock and Dam (from U.S. Army Engineer District, Pittsburgh 1994)

### **Stonewall Jackson Dam**

Stonewall Jackson Dam is located on the West Fork River about 5 km (3 miles) south of Weston, WV. The concrete gravity structure, consisting of 16 monoliths, is 189 m (620 ft) long and 29 m (95 ft) high. It has an uncontrolled ogee-type center spillway. Three 1-by 2-m (3-1/2- by 7-ft) flood-control sluices and two 0.8- by 1.2-m (2-1/2- by 4-ft) water-quality control sluices discharge into a concrete stilling basin with baffle piers and an end sill. Each sluice has a service gate and an emergency gate arranged in tandem. A 533-mm- (21-in.-) diam bypass conduit maintains downstream flow during periods when the stilling basin is dewatered for inspection or maintenance. The bypass has its own stilling basin located at the downstream end of the left training wall.

During construction, problems with concrete mixture and placement caused entrapped air holes, or “bug holes,” to develop in the faces of the dam and sluices. Several attempts to reduce or eliminate this problem were unsuccessful. It was not until the later stages of construction that a change in the vibrating procedure greatly reduced and in some cases eliminated the formation of the bug

holes. A modification was issued to fill the deeper holes in the sluices and rub all the faces of the dam with a cement grout. The result is a more attractive surface, but one that may be subject to early weathering and damage from cycles of freezing and thawing. Several areas remain rough after treatment, including the right end of the spillway crest, the top of the penstock plug on the downstream face of Monolith 4, around the air vent in Monolith 16, and on both spray walls. There is some spalling of the surface layer of grout along vertical downstream monolith joint 7/8. Minor patching has been done at monolith joint 3/4, 11 lifts down from the top and near the upstream bases of both water-quality towers.

Another problem was that the crews working on the dam lacked experience in placing and consolidating mass concrete. Incorrect placement and consolidation resulted in open lift joints and leakage into and through the dam when the reservoir was partially filled in May 1988. Subsequent falling-headwater tests conducted in the fifteen 203-mm- (8-in.-) diam monolith joint drains during September-October 1988 confirmed the existence of leaks in the upstream and downstream faces and in the galleries of the dam. The seepage was identified as occurring through both horizontal lift joints and vertical monolith joints.

**Grouting monolith joints and drains.** On 9 November 1988, USAED, Pittsburgh and Mobile, personnel met to discuss the remediation needed to reduce the joint seepage at Stonewall Jackson Dam. Their decision was to use portland cement to grout the 15 monolith drains. The 11 drains accessible from the dam crest would be reamed out with a roller bit after grouting was completed to restore them. The four drains accessible only from the spillway would be left grouted. Grouting would be performed to just above the horizontal 76-mm (3-in.) drain pipes that empty into the drainage gallery so that they would not become permanently plugged. The work was carried out in December 1988 with the USAED, Mobile, performing the drilling and grouting and the USAED, Pittsburgh, providing onsite inspection of the operation.

Prior to grouting, the length of each hole was sounded with a weighted tape. A plug was placed in the horizontal 76.2-mm (3-in.) drain pipe, and then the 203-mm (8-in.) drain was filled with fine sand to a height of 1.2 m (4 ft) above the pipe to prevent permeation of grout into it.

An initial grout mixture with a w/c of 0.9 by weight of cement (1.33 by volume) was used for all holes. The mixture was then thickened as necessary. A prepackaged additive containing a grout fluidifier and an expansive agent was also used in amounts equivalent to 1 percent by weight of cement. The grouting pressure was limited to that exerted by the weight of the column of slurry in a full drain hole. After their initial filling, the holes were kept full by the addition of more grout in order to maintain the pressure. A record was kept of the total amount of cement used in each drain hole. In addition, an estimate was made of the volume of grout used in excess of that required to fill the drain.

After being grouted, each of the 11 drains to be reamed was allowed to cure for a minimum period of 2 days to prevent the fresh grout from being washed out. A 200-mm (7-7/8-in.) roller bit was used for the drilling. Following the

drilling, each drain was flushed with water to remove the remaining sand and drill cuttings. Falling head water tests were then conducted to help determine the effectiveness of the grout seal.

On two occasions, grout leakage through the joints was so excessive that the grout mixture was thickened. While drain 6/7 was being grouted, an extensive leak appeared on the upstream face. The seepage exited between el 1,035 and 1,040. Grout batches were subsequently thickened to a 0.53 w/c; eventually the leak stopped. The grout take was very large, suggesting that the aperture of this monolith joint was larger than those encountered while grouting lift joints. A leak approximately 1.8 m (6 ft) wide also appeared at the el 1,065-ft joint of Monolith 6, immediately adjacent to the monolith joint.

While drain 8-9 was being grouted, a leak appeared on the downstream side of the monolith joint. Grout was observed flowing as high as el 1,065; however, most of the grout was exiting between el 1,045 and 1,050 ft. Although subsequent grout batches were thickened to 0.4 w/c, grout continued to leak through the joint. Later that day, a fine, uniform sandblasting sand was added to three thick batches at a 0.2 sand-cement ratio, resulting in a slowing down of the leak. The following morning, bentonite was added to further thicken two batches in amounts equivalent to 3 percent by weight of cement. The leak subsequently stopped. A total of 60 bags of cement was used.

A comparison with results of water tests conducted before and after grouting revealed that marked decreases in drain flows were achieved by the grouting operation. However, since the water tests were performed in the grout holes and radial flow is heavily influenced by conditions close to the hole, the tests do not indicate the extent of grout travel through the lift joints. Although there was evidence of grout migration across monoliths, it is expected that, in most cases, the grouting operation was not able to seal the portions of the lift joints between the drains. It is believed flow through lift joints could still be possible, and the drains might be incapable of reducing uplift pressures because of the decrease in drainage efficiency.

**Sealing parapet wall and tower access stairs.** The Second Periodic Inspection of Stonewall Jackson Dam (USAED, Pittsburgh 1989b) noted numerous "bug holes" throughout all monoliths and the tower access stairs (Figure 75). There were vertical cracks beneath the open joints of the parapet wall that extended onto the dam face for 0.6 to 0.9 m (2 to 3 ft). It was recommended that these cracks be sealed with Plasti Dip Film when funding became available. Hairline cracks on the dam face above the pump door and conduit cover at the water quality tower No. 1 and near the pump door of water tower No. 2 were to be sealed.

The access stairways for both water quality towers had separated from the face of the dam (Figure 76). Water quality tower No. 1 also had a crack about midway underneath the stairs. Water quality tower No. 2 had a spalled area approximately 13 mm (1/2 in.) deep on the bottom platform of the stairs (Figure 77). Minor deterioration was also noted around monolith joint drains.

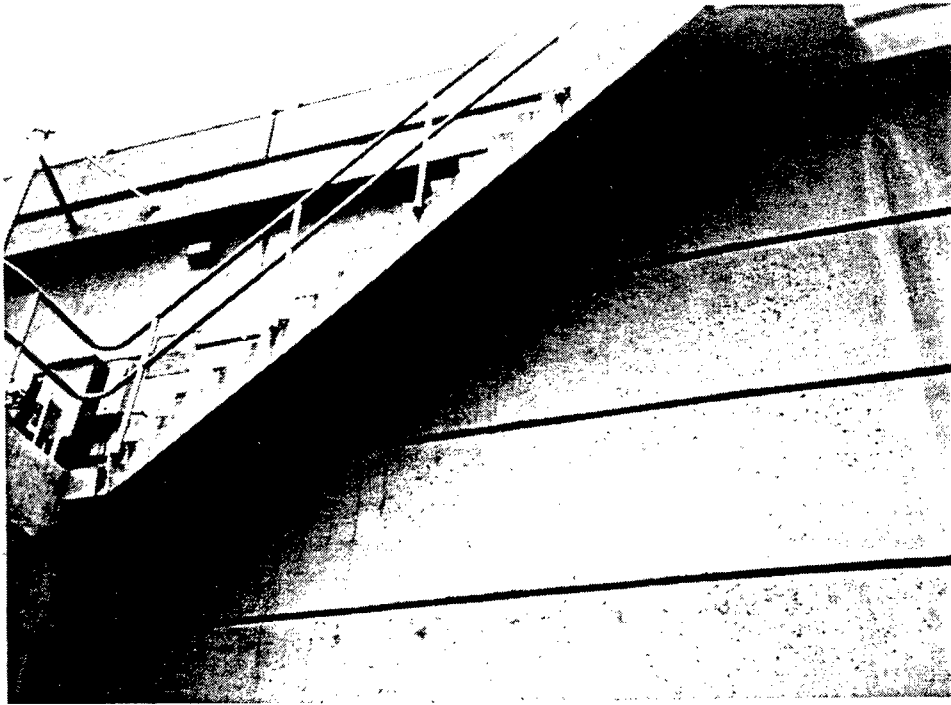

Figure 75. Bug holes on the upstream face of Stonewall Jackson Dam (from U.S. Army Engineer District, Pittsburgh 1989b)

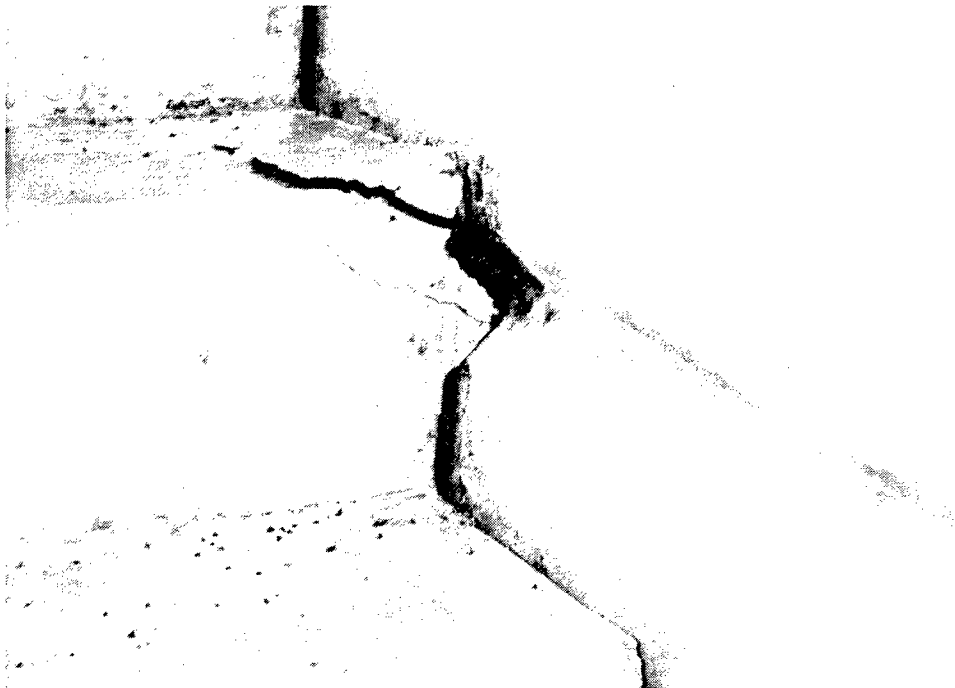

Figure 76. Access stairway for tower no. 1 separated from dam face at Stonewall Jackson Dam (from U.S. Army Engineer District, Pittsburgh 1989b)



Figure 77. Spalling beneath access stairway at water quality tower no. 2, Stonewall Jackson Dam (from U.S. Army Engineer District, Pittsburgh 1989b)

There were minor cracked and spalled areas on the faces of the upstream monoliths. Although the deterioration was minor, it was recommended that all cracks be sealed and that spalled areas be repaired to prevent further damage.

There was slight seepage on the spray wall of Monolith 5 and seepage/leakage across the lift joint near el 1,027 on Monolith 6 (Figure 78). The leakage was considered nominal with possible self-sealing potential. No immediate repair plans were made (USAED, Pittsburgh 1989b).

The Fifth Periodic Inspection (USAED, Pittsburgh 1992) noted that the general condition of concrete in the dam was slightly more deteriorated and discolored. This condition was attributed to spalling and the discoloration of the surfaces that were "rubbed" with cement grout during construction to fill bug holes. This condition was considered to affect appearance only and to be of no structural significance.

Brackets were installed to support the water quality tower access stairways, which had pulled away from the dam face (Figure 79). The stairs were then considered to be stable.

Minor seepage was noted at monolith joints 5/6 and 8/9. These are two of the monolith joints that were not reamed out during the 1988 grouting program. Although the area around monolith joint 5/6 was wet during the Seventh Periodic Inspection (USAED, Pittsburgh 1995a), no stream of water was observed.





Figure 78. Leakage at monolith joint 5/6, Stonewall Jackson Dam (from U.S. Army Engineer District, Pittsburgh 1989b)

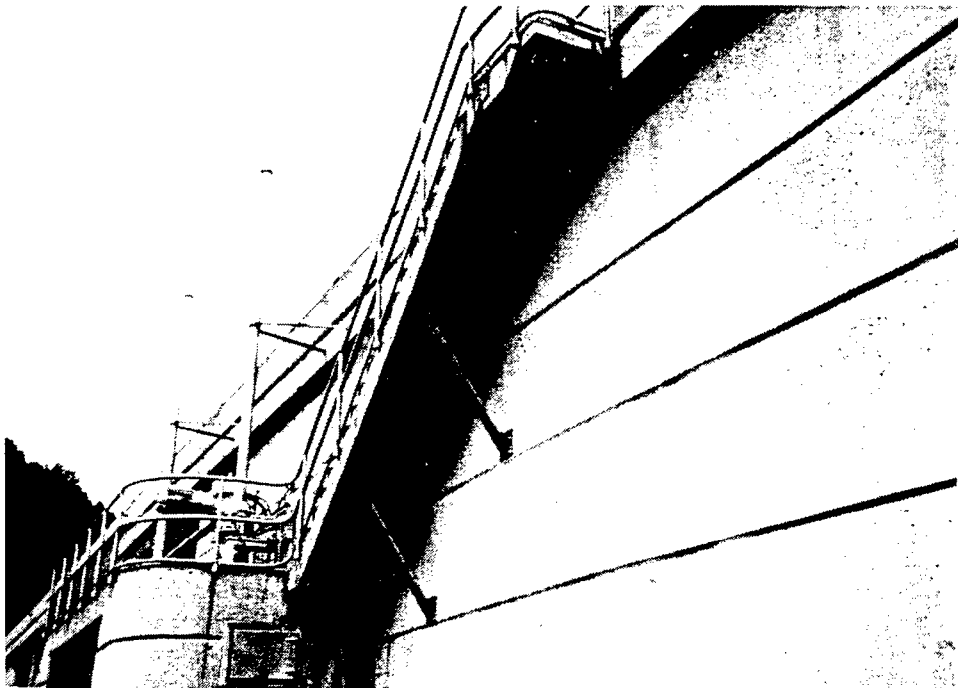

Figure 79. Stainless steel brackets installed to support water quality tower stairway, Stonewall Jackson Dam (from U.S. Army Engineer District, Pittsburgh 1992)

Otherwise, there was no significant change in the condition of the concrete surface of the downstream face of the dam.

## **Tygart Dam**

Tygart Dam is located on the Tygart River approximately 184 km (115 miles) south of Pittsburgh in Taylor County, West Virginia. The dam was constructed between December 1934 and February 1938.

The crest of the 586-m- (1,921-ft-) long gravity-type structure is 70 m (230 ft) above the original streambed. It has an elevation of 1,190 msl. The uncontrolled spillway, located at the center of the dam, is 149 m (489.3 ft) wide and has a crest el at 1,167l. Eight 1.7- by 3-m (5-ft 8-in. by 10-ft) conduits, each regulated by hydraulically operated service and emergency slide gates, control discharge. Two 1,067-mm (42-in.) gate valves handle low flow discharge. The stilling basin is 68 m (223 ft) long from the sluice outlets to the downstream stilling weir.

Following the Fourth Periodic Inspection (USAED, Pittsburgh 1985), the concrete roadway on the right side and the parapet walls were repaired. Prior to the repair, core samples of the concrete were sent to U.S. Army Engineer Division, Ohio River (ORD), laboratory for petrographic examination. Test results indicated the deterioration was caused by cycles of freezing and thawing, but there was no evidence of alkali-aggregate reaction. Deteriorated concrete was removed and replaced with latex modified concrete. The repair work was completed in 1986 at a cost of \$195,000. Final inspection was conducted December 3, 1986. During that inspection, spalling in the patch and repair areas in the roadway overlay in Monolith 5 was noted; however, a follow-up inspection May 15, 1987, revealed that this repair and patch area had not changed significantly during the 5-month period.

Findings of the Fifth Periodic Inspection of Tygart Dam (USAED, Pittsburgh 1990b) indicated that the latex concrete repairs on the right-side roadway and parapet walls were in very good condition. Neither the downstream nor upstream faces of the dam were in need of repair.

The latex concrete repairs on the right-side roadway and parapet walls were still in good condition, with only some minor crazing of the concrete surface, at the time of the Sixth Periodic Inspection (USAED, Pittsburgh 1995b).

## **Mobile District**

### **Columbus Lock and Dam**

Columbus Lock and Dam is the third navigational structure on the Tennessee-Tombigbee Waterway above Demopolis Lock and Dam. It is located at river

mile 370.14, or about 6.4 km (4 miles) northwest of Columbus, MS. Principal features of the project are a gated spillway with five 18.3-m (60-ft) gates, abutment walls, a minimum flow structure, a system of overflow and nonoverflow dikes, and a 33.5- by 183-m (110- by 600-ft) lock with a 8-m (27-ft) lift. Construction on the project was initiated in April 1975 and was essentially complete by 1985 except for recreational facilities.

In November 1979, during a period of high water, the gallery access stair shaft and gallery equipment access shaft exhibited signs of leakage. Leakage was located in monolith D3 near a lift line at el 143 in the stair shaft and at el 138 in both the stair and gallery equipment access shafts. An inspection of the downstream face of D3 revealed cracks and mild spalling in these areas.

In May 1980, when floodwaters receded, further cracking was discovered on the upstream faces of Monoliths D1, D2, and D3. Lift lines at el 158 and 163 in Monoliths D1 and D2 had horizontal cracks. A diagonal crack stretched from the joint between Monoliths D2 and D3, el 152, to the edge of Gatebay 1, near el 133.

No cause was determined for the cracking, and there was no indication that the cracks extended into the gallery or across gate bays. An epoxy injection system was chosen as the initial approach to repair. The first step in the repair was to seal the surface of each crack and install threaded nipples every few feet for injection. Next the cracks were cleaned with a weak acid solution and flushed with water. The final step was to inject a fast setting epoxy under about 0.11 MPa (5 psi) pressure. The repair was made in June 1980. Brass inserts were installed at the cracks in Monoliths D1, D2, and D3 at the same time.

Stability analyses were performed on the cracked sections in Monoliths D2 and D3. Since the extent of the crack in Monolith D3 was not known, stability was checked on an assumed horizontal cracked section at el 143. Computations indicated there was compression across the entire section. The same was true for Monolith D2 at el 158.

An inspection of the epoxy injection repair in September 1980 revealed that the repair had failed. Two cores were taken from Monolith D2 and one from D3. The cores broke at the crack. Epoxy had filled the crack in each core but had not bonded to both sides of the crack.

An investigation into the possible causes of the cracking in the three monoliths included an analysis of construction records. These records included concrete compressive strength tests, sequence and dates of placement of concrete and backfill, and settlement plug readings. The average compressive strength of the concrete in the location of the cracks was approximately 27.6 MPa (4,000 psi). All concrete in the cracked monoliths had strengths well above the design strength; however, weak planes may have existed at lift lines. There was no correlation between concrete and backfill placement and settlement plug readings, so the sequence of placement was not considered important, but the dates of placement may have been significant. All of the top three lifts in

Monoliths 13L, D1, D2, and D3 (with the exception of the second and third lift from the top in D2) were placed between October 1977 and February 1978. Concrete temperature could have increased substantially from winter to summer, resulting in concrete expansion. Thermal expansion of the top three lifts of concrete is considered to be one possible cause of the cracking.

## Wilmington District

### Philpott Lake Dam

Philpott Lake Dam was constructed in the Roanoke River Basin in Virginia in the early 1950s. The dam, a 272-m- (892-ft-) long gravity structure, includes two nonoverflow sections, a power intake section, and a spillway section. The first periodic inspection of the structure was performed in 1966 (USAED, Wilmington 1966). At that time a crack was observed at el 965 and 972 at the intersection of the ceiling and downstream wall of the spillway gallery. The crack extended completely across Monoliths 11 and 12 and 0.6 m (2 ft) into Monolith 10. There was no documentation as to when the crack first appeared; project personnel reported that it had existed for a number of years. No action was taken.

In July 1968, project personnel reported that the crack had widened and now extended completely across Monolith 10. Also, another horizontal crack had developed along a horizontal lift joint near the gutter at the upstream wall of the gallery. In some places the crack dipped down into the bottom of the gutter.

In August 1968, a formal inspection of the gallery cracks was conducted. The conclusion of this inspection was that no imminent hazard existed; however, it was recommended that micrometer measurements across the cracks be taken, a stability analysis be performed on the portion of the spillway crest above the location of the cracks, exploratory drilling be done to determine the extent and width of the cracks, and repair plans be made.

Crack measurements indicated upstream and downstream movement and opening and closing of the cracks. The exploratory drilling in the spillway was unsuccessful, but approval to make repairs to the spillway was obtained in May 1969. The contract for repairs was awarded in September and the work completed in December 1969 at a cost of \$70,000.

Cracks were monitored for 1 year, and then anchors were installed at 2.4-m (8-ft) centers along the spillway crest and posttensioned to 1,112 kN (250 kips). The anchors were installed to arrest the growth of cracks in the spillway gallery and to improve the safety factor against sliding (for the "cracked section"). The vertical and horizontal components of the posttensioning force represent approximately 46 and 11 percent of the deadweight of the "cracked section," respectively. From available data, there was no indication of any change in the cracks either during tensioning or immediately following installation of the anchors.

Continued monitoring has revealed a gradual trend for the upper portion of the spillway ("cracked section") to move in the upstream direction. This movement may be attributed to the horizontal component of the posttensioning force. If the upstream crack at the gallery gutter elevation had not been intersected by the anchors during posttensioning, the forces applied might very well be prying the "cracked section" off and into the reservoir.

Although the amount of movement in the upstream direction at the current time is minimal, monitoring is being continued, and should the stability of the spillway be affected, remedial action will be taken. One approach being considered is to release the force on the existing anchors. This modification will turn the active posttensioning system into a passive posttensioning system that will exert force on the spillway only during periods of flooding to prevent the "cracked section" from "sliding."

The Fifth Periodic Inspection (USAED, Wilmington 1988) noted cracking along the ceiling and gutter in the spillway gallery, in the head-gate bay area, the south gallery access and the head-water gauge access. There had been some movement in the entrance to the head-gate bay area as the watertight door was difficult to open. Less significant cracking was observed throughout the dam. The exterior of the dam had some areas of spalling but, in general, the concrete was considered to be in good condition. The upper portion of the spillway still tended to move in the upstream direction. No remedial action was planned at the time.

A crack condition survey of the concrete dam was performed by WES in October 1992 (USAED, Wilmington 1993). A comparison of the results of this survey with a survey in June 1987 showed no significant change in the condition of the dam.

Since the last inspection, horizontal movement toward the lake in the upper spillway gallery had not exceeded 2.5 mm (0.1 in.). This amount of movement was not considered to be serious; however, monitoring of the upper spillway gallery would continue. Tilt sensors installed in the upper spillway gallery in 1986 indicated no significant tilt toward the lake; however, a downstream tilt sensor showed positive tilting at a rate of about 0.52 min/year. This situation would be monitored.

The head-gate bay and south gallery access were instrumented in 1985 with crack measuring devices. These devices indicated a steady increase in crack width. Vertical movement was small in the head-gate bay access, but in the south gallery access movement had been about 0.5 mm (0.02 in.) per year. Horizontal movement had been little to none. There was no concern about the stability of the structure.

## Albuquerque District

### Abiquiu Dam

Abiquiu Dam is located on the Rio Chama River about 80 km (50 miles) northwest of Santa Fe, NM, in Rio Arriba County. The dam was completed in 1963 by the USACE as a part of the water resources development scheme for the Rio Grande watershed. The 103-m- (338-ft-) high, 469-m- (1,540-ft-) long earth-fill dam drains a 5,579 sq km (2,154 square mile) watershed and impounds a 44,652,700-cu m (362,000 acre-ft) pool. In addition to providing flood and sediment control, the reservoir is used for recreation and irrigation.

The original outlet works at the dam consisted of an intake, a 3.7-m- (12-ft-) diam concrete lined outlet tunnel, a gate chamber, service gates, and a flip-bucket energy dissipator. The tunnel consisted of two sections: a 204-m- (669-ft-) long pressurized section upstream of the service gates and a 430-m- (1,411-ft-) long free-flow section downstream of the service gates. A 4.9-m- (16-ft-) diam vertical shaft extending 91 m (289.5 ft) to the dam surface provided access to the gate chamber, which housed two hydraulically operated gates and their auxiliary equipment. Two 0.9-m- (3-ft-) diam pipes supplied air from the shaft to the tunnel downstream of the service gates.

For normal flow, the Corps regulated discharge through the outlet works by operating the gates and keeping the downstream tunnel section in the open-channel-flow mode. During low flow, the flip bucket at the end of the tunnel performed as a hydraulic-jump stilling basin and, at high flow, it served as a means to divert water from the dam toe and left abutment. The capacity of the outlet works was 232 cms (8,192 cfs).

In the mid-1980s, the Incorporated County of Los Alamos sought permission to construct a hydroelectric power project at the dam, which is owned by the USACE and operated through the USAED, Albuquerque. Any modifications to the dam had to meet Federal guidelines, which stated that new construction could not affect the structural integrity, safety, or operation of the existing facility. The county had a Design Report prepared and approved by the USACE before construction began. This case study is a summary of a report on the modifications by Kneitz (1991).

The addition of the hydroelectric power project at the dam required modification of the outlet works so that reservoir releases previously made through the dam outlet works would pass through the hydroelectric facility. During power generation, the entire outlet tunnel had to be pressurized to the existing reservoir water surface. Modifications required to accomplish this task included lining the tunnel with steel, strengthening the air vent pipes to support the additional loadings, and constructing a plenum chamber to connect the hydrofacility penstock to the outlet works (Figure 80). With the completion of these modifications, discharges up to 71 cu m/s (2,507 cu ft/s) are now directed through the hydrofacility; discharges in excess of this amount bring powerhouse shutdown and the return of flow regulation to the USACE.

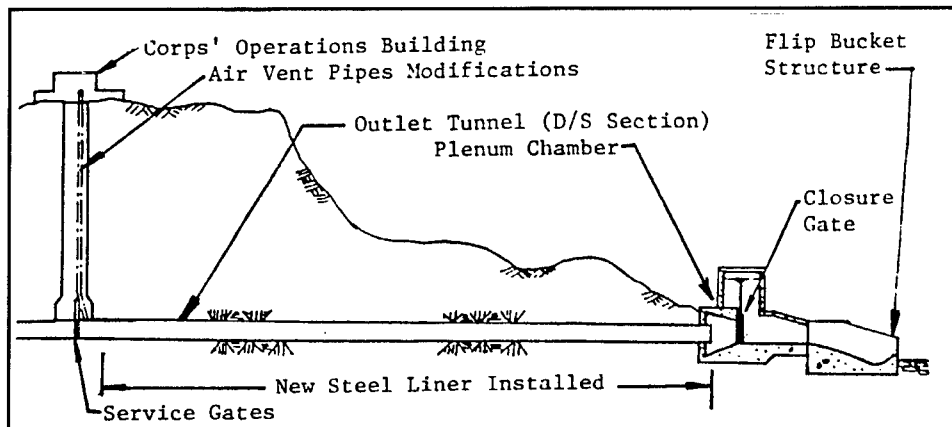

Figure 80. Plan for outlet works modification at Abiquiu Dam

The downstream section of the tunnel was lined with a 428-m- (1,404-ft-) long, 3.4-m- (11.2-ft-) diam circular steel liner. A 3.7-m- (12-ft-) long rectangular-to-circular transition section was installed between the liner and the service gates to reduce headlosses. The other end of the liner is connected to the plenum chamber liner.

The thickness of the liner plate, which was determined by an analysis of pressure developed by external loading, tapers from 25 mm (1 in.) at the upstream end to 15 mm (0.6 in.) at the downstream end where it connects to the plenum chamber liner. The liner plate was shop-fabricated in 12.2-m- (40-ft-) sections for shipping. The sections were field welded into 36.6-m- (120-ft-) long pieces to be pulled into the tunnel. To provide a level area for the sections so they could be pulled into the tunnel, the flip bucket was filled to the tunnel invert. A winch anchored to the steel-lined pier that separates the two upstream service gates was used to pull each section into the tunnel. To facilitate pulling, each section was supported by several sets of steel-wheeled dollies that rode in a steel-channel track bolted to the concrete lining. Once the sections were in place, connections between pieces were field-welded from inside the liner, and then the entire tunnel liner was grouted in place with nonshrink grout. The grout was placed in three stages to prevent gaps from developing behind the liner: encasement grouting, contact grouting between the encasement and the existing concrete lining, and contact grouting between the encasement and the steel liner. Installation of the steel liner took approximately 90 days.

A plenum chamber was installed at the end of the downstream tunnel liner to convey water from the tunnel to the hydrofacility under the power generation mode and to supply a transition from the tunnel to the flip bucket during flood control (Figure 81). Hydraulic model studies of the plenum chamber configuration were conducted in late 1986 at Colorado State University to ensure the design would not create a shape of discharge from the flip-bucket structure significantly different from the discharge that would occur in the outlet works without the plenum chamber addition, would create no significant negative

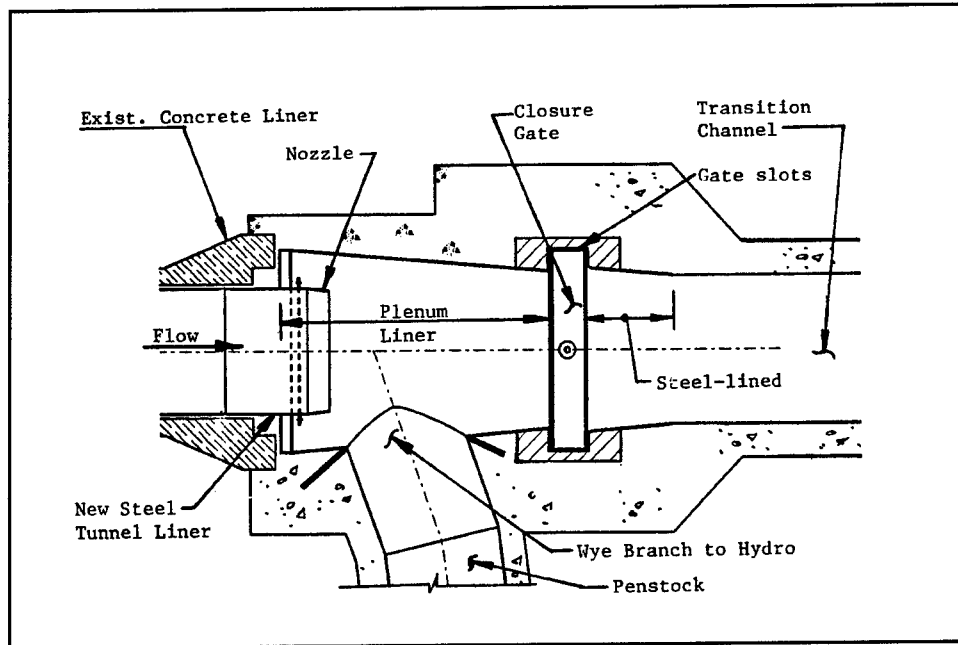

Figure 81. Plenum chamber at Abiquiu Dam (from Kneitz 1991)

pressures that could cause cavitation or other adverse effects on the structure, and would not impinge the jet onto the crotch plate of the side outlet to the penstock.

The plenum chamber is a 7.2-m- (23.5-ft-)long steel cone encased in concrete. At its widest point, the cone has a 5.5-m (18-ft) diam; at its narrowest, a 4.3-m (14-ft) diam. A 3.2-m- (10.5-ft-) diam side outlet leads to the hydrofacility. Three 0.9-m- (3-ft-) diam air vent pipes with butterfly valves were installed at the plenum chamber crown and penstock to provide air to the plenum during flood-control operation. The sidewalls of the transition channel that connects to the flip bucket were lined with stainless steel. This section tapers to a point 3.4 m (11 ft) downstream of the gate slots. Also, the center line of the branch into the penstock was raised 20 deg above the horizontal to move the crotch of the wye branch out of the path of water exiting the tunnel during flood-control operation.

The downstream closure gate for the plenum liner is a 5.5-m- (18-ft-) wide by 4.6-m- (15-ft-) high slide gate with a rubber bulb seal. The bulkhead-like gate is operated by a 6.7-m-(22-ft-) long single-acting hydraulic cylinder mounted in the gate body. Because of the upstream seal arrangement of the closure gate, fabrication and installation tolerances for the gate leaf and seal plates were critical. To achieve the required fit for correct sealing of the gate, it was necessary to field machine the seal plate surfaces.

In March of 1991, the hydraulically operated service gates of Abiquiu Dam were inspected and repaired. To perform the repairs, workers had to retrieve two steel bulkhead gates from their underwater stored position and place them so that



they would seal the intake control structure of the dam. Because of shoreline and intake geometry, a crane operating from land could not be used to maneuver the 9,979-kN (11,000-lb) gates. Instead, a waterborne crane mounted on a Flexifloat barge and a team of divers were contracted from Oceaneering International, Inc., for the project. The 16- by 13.7 by 1.2-m (52.5- by 45- by 3.8-ft) "L"-shaped operations barge was assembled with seven 9.1 by 2.2 by 1.2-m (30- by 7.5-ft by 3.8-ft) Quadra-floats, four 4.6 by 2.3 by 1.2-m (15- by 7.5- by 3.8-ft) Duo-floats, and two 4.6 by 2.3-m (15- by 7.5-ft) loading ramps (Figure 82). The barge was powered to the work site by three Army MK-1 jet boats and anchored on location with cables and buoys.

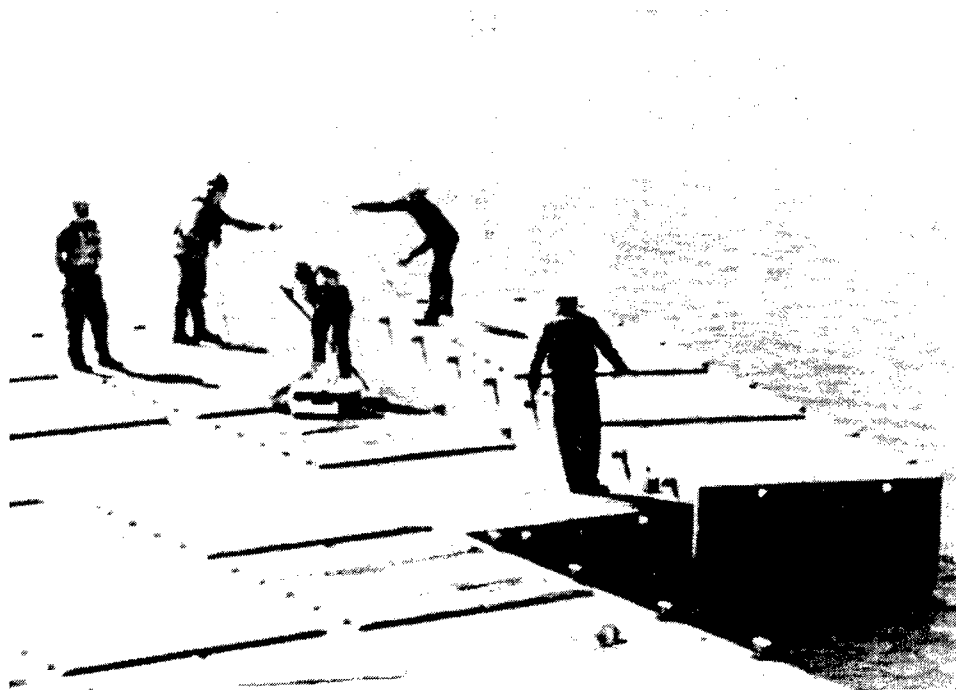

Figure 82. Flexifloat barge assembly, Abiquiu Dam (from Oceaneering International, Inc. 1991)

An underwater inspection of the bulkhead gates and their components revealed aquatic growth on the walls, corrosion of the retaining bars and flapper valves, aquatic biofouling, and an accumulation of debris under the gates. However, the gates were assessed as operational and were moved to the closed position with the barge-mounted crane. With the gates in place, the intake tunnel was dewatered. An inspection showed that both gates were leaking from the top of the "J" seal area. Each area of leakage was approximately 1.6 mm (1/16 in.) wide and between 0.6 and 0.9 m (2 and 3 ft) long. Burlap and Duxseal were placed into the openings; leakage was reduced by 75 percent.

Once the internal repairs were completed, a decision was made to retrieve the bulkhead gates (Figure 83) and take them to the boat ramp area where they could be thoroughly examined. The moderate corrosion and aquatic biofouling had prevented workers from determining the true condition of the gates.

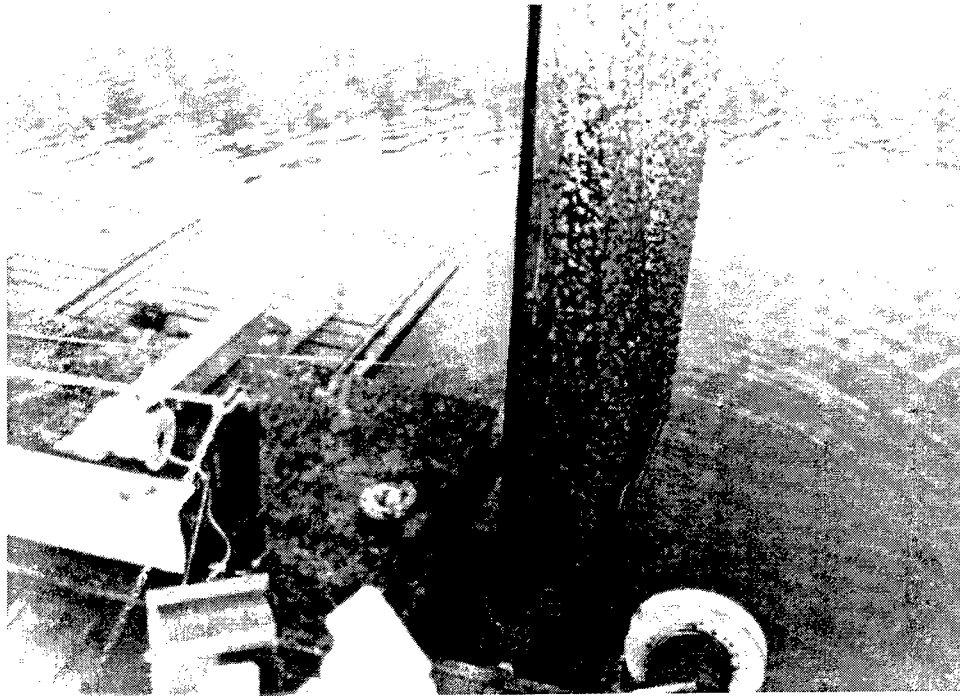

Figure 83. Removal of south bulkhead gate, Abiquiu Dam (from Oceaneering International, Inc. 1991)

Upon completion of the project, all equipment was loaded and demobilized (Oceaneering International, Inc. 1991).

## Little Rock District

### Clearwater Lake Dam

Clearwater Lake Dam is located on the Black River in Piedmont, MO. The dam, completed in 1950, is an earthen embankment 1,297 m (4,255 ft) long with a maximum height above streambed of 47 m (154 ft). The outlet works is located on the right abutment. It consists of an approach channel, a gated intake tower, a 7-m- (23-ft-) diam concrete lined tunnel, service bridge, chute and stilling basin, and a discharge channel. The dam impounds 482,298,500-cu m (391,000 acre-ft) of water and has a discharge capacity of 3,540 cms (125,000 cfs).

In July 1987, cracks in the left wing wall of the stilling basin were repaired. The cracks, which were primarily the results of aging, ranged from hairline to 6.4 mm (1/4 in.) in width and up to 7 m (23 ft) in length. They extended from the top of the wing wall, starting at the rip rap area, and extended to the mouth of the tunnel below el 452.1.

The repair procedure was to remove loose concrete, chisel out the cracks to a width and depth of 19 mm (3/4 in.), clean them with a wire brush, and then fill

them with joint compound. A standard caulking gun was used to apply the joint compound.

The cost of the repair was \$1150.00, \$350.00 for materials and \$800.00 for labor. A 1991 inspection showed that the repair was still in satisfactory condition.

In 1989, twelve areas of deterioration on the service bridge of the control tower were repaired. The deterioration, which was concentrated along the sides of the bridge surface where the bridge intersects with the wall, was caused by weathering. The size of the damaged areas averaged 0.09 sq m (1 sq ft) with a depth of 12.7 mm (1/2 in.).

Deteriorated concrete was ground from the damaged areas, and then the areas were cleaned with a wire brush. Cat Coat Brand, 2-part, underwater coating No. 1-140-2 was used to fill the repair areas. Components were mixed and poured into depressions to the level of the bridge surface.

Cost of these repairs was \$300.00 for materials and labor. A year later, the edges in 50 percent of the repairs were popping up. The repair failure appeared to be a bond failure caused by moisture and weather.

The Seventh Periodic Inspection (USAED, Little Rock 1994) found that the cracks in the stilling basin left training wall that were sealed in 1988 were still sealed, and the service bridge was in excellent condition.

## **DeQueen Dam**

DeQueen Dam is located on the Rolling Fork River about 11 km (7 miles) northwest of DeQueen, AR. The dam, which was completed in 1969, has a crest length of 719 m (2,360 ft) and a height of 48.8 m (160 ft). The side slopes of the outlet channel are covered with riprap to prevent erosion. During periods of high discharges, some of this riprap washes into the stilling basin where it is tossed around by turbulent water until it disintegrates. This abrasive action also wears the concrete on the stilling basin floor, the baffle blocks, and in the ogee section of the stilling basin. In an attempt to decrease the amount of riprap entering the basin, the existing barrier fence on top of the training walls was extended to 2.4 m (8 ft), and a concrete slurry overlay was placed over a portion of the riprap slope. These preventive steps decreased the problem, but did not eliminate it. The stilling basin had to be repaired in 1982 and again in 1989.

The repair of the stilling basin in 1982 consisted of placing a reinforced concrete overlay on the entire floor slab, the baffles and walls, constructing a concrete filler between the floor slab and end sill, applying a protective coating on the surface of all new stilling basin concrete, and adding a concrete slab and walls in the outlet channel for a distance of 24.4 m (80 ft) downstream of the stilling basin.

Since the repairs were to be performed in the dry, the contractor constructed a downstream cofferdam, and had the lake lowered approximately 3 m (10 ft) to provide additional storage space, thus reducing the possibility of lake water being released during the 60-day period estimated for the repairs. The outlet works gates were closed, and the contractor constructed a sandbag dike to pond any leakage through the upstream gates. One of the most difficult tasks involved in the repair was keeping the work area dewatered. Pumps were used to maintain a minimum flow of 0.23 cu m/s (8 cfs) in the downstream channel.

Areas of damaged concrete were saw cut and the concrete was removed to a depth of 51 mm (2 in.) below the reinforcing steel. Damaged reinforcing steel was replaced. Reinforcing steel that remained was straightened and cleaned. All repair surfaces were thoroughly cleaned with high-pressure water jets. Existing drains were cleaned and pipe for extensions and new drains were installed. Anchor holes for the concrete overlay were drilled and the anchors grouted into place with nonshrink grout at least 6 days before concrete was placed to allow the grout to set. Rock was excavated from the outlet channel, and the channel surface was cleaned in preparation for the concrete repair work.

Concrete for the overlay consisted of portland cement, water, fine and coarse aggregate, and an air-entraining admixture. Compressive strength specifications for the concrete at 28 days were 34.5 MPa (5,000 psi) for concrete used within the stilling basin and outlet channel and 20.7 MPa (3,000 psi) for all other concrete. The design mixture proportions for the concrete were tested by an independent commercial testing laboratory. Concrete was placed within 45 min of being mixed and was compacted with mechanical vibrating equipment supplemented by handspading and tamping. Construction joints in the new stilling basin concrete slab were placed over the joints in the existing slab. New concrete was moist-cured for 7 consecutive days. After repairs were completed, an epoxy coating was placed on the new portland cement concrete overlay on the upstream face, the top of the baffles, and the exposed surface of the concrete fillet at the end sill.

The cost of the 1982 repair, which was accomplished by contract, was \$168,795.55. Continued erosion of the stilling basin concrete necessitated another repair of the stilling basin floor in 1989. In-house personnel performed this repair in basically the same way as the 1982 repair. Cost of this repair is unknown.

In 1993, the stilling basin was dewatered for repairs. The parabolic section floor was generally in good condition, with the severest erosion in the central portion. It extended about 0.9 m (3 ft) upstream of the stilling basin floor and was from 51 to 76 mm (2 to 3 in.) deep, but none of the reinforcing was exposed. The area between the upstream row of baffles and station 20+30 (Figure 84) was in badly eroded condition. Erosion reached a maximum of 279 mm (11 in.), and almost all of the reinforcing was exposed. There were two other large eroded areas and several smaller areas. The baffles were in good condition.

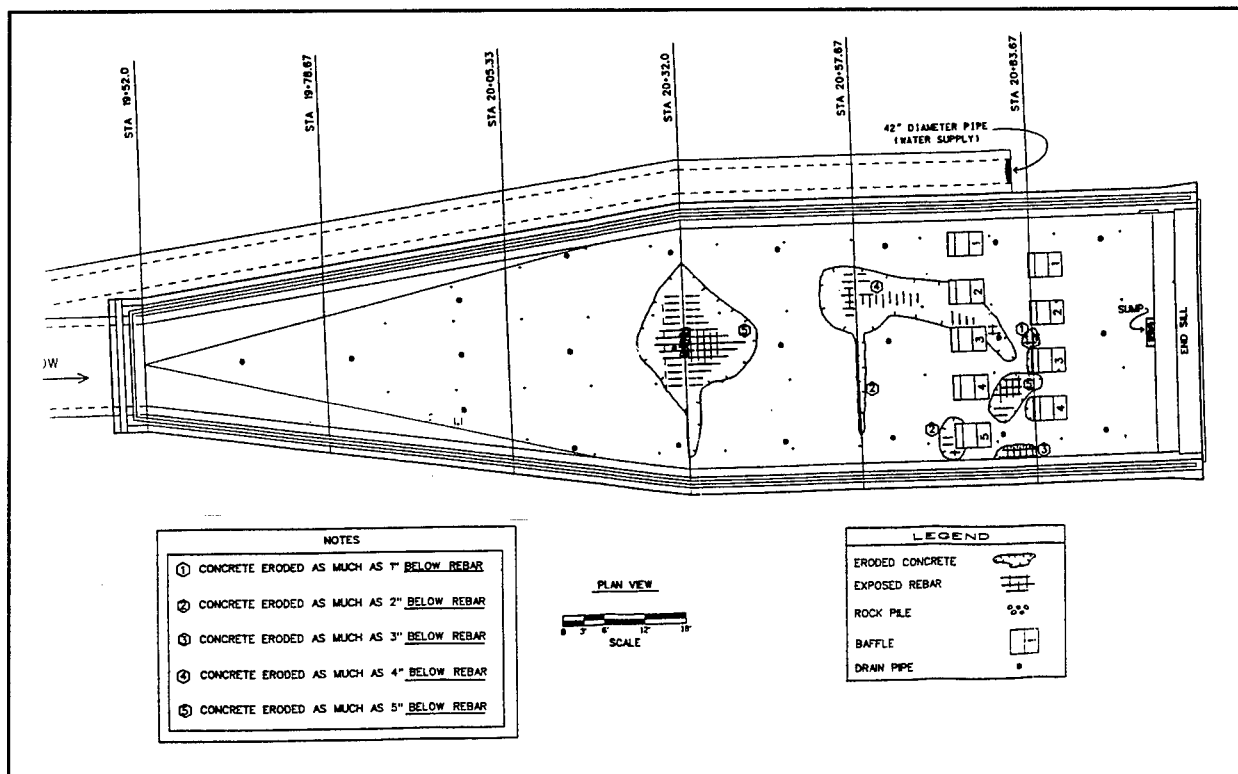

Figure 84. Condition of stilling basin at DeQueen Dam 1993 (from U.S. Army Engineer District, Little Rock 1997a)

Prior to the repair, workers removed approximately 0.4 cu m (1/2 cu yd) of rocks from the stilling basin. The rocks ranged in size from 25 to 203 mm (1 to 8 in.) in diameter. Divers examined the outlet works gate tower and the outlet conduit but found no evidence that the rocks were passing through from upstream. The entire stilling basin floor and the lower 0.9 m (3 ft) of the paraolic drop-section floor were covered with a 102-mm (4-in.) overlay of silica fume concrete. It was recommended that all ungrouted riprap on the left and right banks of the stilling basin from the downstream end of the basin to the public access steps be grouted.

The Eighth Periodic Inspection (USAED, Little Rock 1997a) indicated that the 1993 repairs were performing well. Minor erosion was continuing, especially in the area of the baffles. Reinforcing was exposed on upstream baffles 3, 4, and 5, and the bottom foot of all baffles had some erosion. The sump was completely filled with rocks and debris, but it was the only area of the stilling basin that contained a concentration of rocks. Some of the rocks were coated with cement grout. Overall, the concrete surfaces were in very good condition.

## Gillham Dam

Gillham Dam is located on the Cossatot River about 32 km (20 miles) northeast of DeQueen, AR. This dam is 533 m (1,750 ft) long and 48.8 m (160 ft) high; it consists of a rolled earth and rock-filled embankment, gated spillway, and controlled outlet works. During the construction of the stilling basin in 1967, no provisions to stabilize the area immediately downstream were made. The side slopes and bottom of the outlet channel were shale and layers of broken sandstone. During times of high discharges, this material was pulled back into the stilling basin by the turbulence of the water. The grinding action of this material resulted in wear to the concrete surfaces. Also, gouge marks in the conduit indicated rocks had entered the stilling basin from upstream.

The stilling basin was repaired by contract in 1983. The contract work consisted of placing a 305-mm- (12-in.-) reinforced concrete overlay on the entire floor slab and on the upstream face and top of all baffles, placing a concrete fillet between the floor slab and the end sill, and applying a protective coating to the surface of all new concrete. A cavity in the west bank of the outlet channel was filled with concrete. In addition to the repairs, pneumatic concrete was placed over the bottom and side slopes of the outlet channel for a distance of 12 m (40 ft) downstream of the stilling basin. This concrete overlay has reduced the amount of rock entering the stilling basin, but it has not eliminated the problem.

Repairs to the stilling basin were performed in the dry. The contractor constructed a downstream cofferdam; the Government lowered the lake approximately 4.6 m (15 ft) to reduce the possibility of water being released into the repair area and closed the gates to the outlet works so the repair area could be dewatered. The contractor supplied the required minimum flow of 0.4 cms (14 cfs) in the downstream channel by tapping into an existing underground water main owned by the Gillham Regional Water Association.

The repair procedure was to remove and replace deteriorated concrete and reinforcing. Deteriorated areas were saw cut in a rectangular shape and the deteriorated concrete removed to sound concrete. Damaged reinforcing steel was replaced. Holes for anchors were percussion drilled and the anchors installed with nonshrink grout a minimum of 6 days before concrete placement. The final preparatory step was to clean the repair area with a high-pressure water jet.

The repair concrete consisted of portland cement, water, fine and coarse aggregate, and an air-entraining admixture. The contractor was responsible for determining the mixture proportions. Specifications called for a compressive strength of 34.5 MPa (5,000 psi) at 28 days for concrete used within the stilling basin and outlet channel and 20.7 MPa (3,000 psi) for all other concrete. An independent commercial laboratory tested the concrete to determine that the mixture met all specifications. Concrete was placed within approximately 45 min of being mixed. It was compacted with mechanical vibrating equipment supplemented by hand spading and tamping and then moist cured for a period of

7 days. Once the concrete was cured and its surface relatively dry, the epoxy coating was applied to the new concrete overlay on the upstream face and top of the baffles, the stilling basin slab and ogee, and the exposed surface of the concrete fillet at the end sill.

A 1988 inspection revealed cracking in the grout caps of the trunnion blocks. The cracking, possibly the result of shrinking, could have allowed water to reach the steel reinforcement, thus threatening structural integrity. A two-part epoxy coating was used to seal the exterior surface of the grout caps. Before the sealant was applied, the surfaces were lightly sandblasted to clean them. The repair work was relatively easy because the lake level during normal pool is below the weir section of the spillway; work could be performed without water flowing through the spillway.

The approximate cost of the 1983 repair work was \$150,000. Cost for sealing the trunion blocks grout caps was \$8,782. The trunion blocks are inspected monthly as part of the maintenance program. Divers who inspected the stilling basin in August 1990 reported some erosion of the concrete surface.

In 1991, numerous high discharges washed approximately 0.4 cu m (1/2 cu yd) of rock into the stilling basin. These high discharges in conjunction with the rock caused significant progression of erosion in the stilling basin floor. A 305-mm (12 in.-) wide band of erosion, 51 to 76 mm (2 to 3 in.) deep, extended across the floor adjacent to the end sill. However, the 12-m- (40-ft-) long concrete slab placed downstream of the end sill in the fall of 1983 was still in good condition. Baffles were generally in good condition; no. 1 and 3 on the downstream row had some exposed reinforcing bars.

Since 1994, deterioration has continued as a result of high flows and trapped rock in the stilling basin. The most severe erosion has occurred downstream of baffles 3 and 4 (Figure 85). The eroded area is 305 mm (12 in.) deep and has exposed reinforcing. The 12-m- (40-ft-) long concrete slab placed in 1983 and the baffles are still in good condition. The district geotechnical section recommended that the stilling basin be dewatered and repaired (USAED, Little Rock 1997b).

## **Norfolk Dam**

Norfolk Dam is located in north central Arkansas on the North Fork River at the White River Basin. Construction of the gravity-type dam was begun in 1941 and completed in December 1944. The dam, which consists of 56 monoliths, has a crest length of 802 m (2,631 ft). The hydroelectric capacity of the dam consists of units in Monoliths 22 and 23 and penstock openings for future use in Monoliths 20 and 21.

The roadway on top of the nonoverflow monoliths of Norfolk Dam cracked near the center line in a longitudinal direction, raising concern about the integrity of the cantilever portion of the roadway section of the dam as some of the cracks

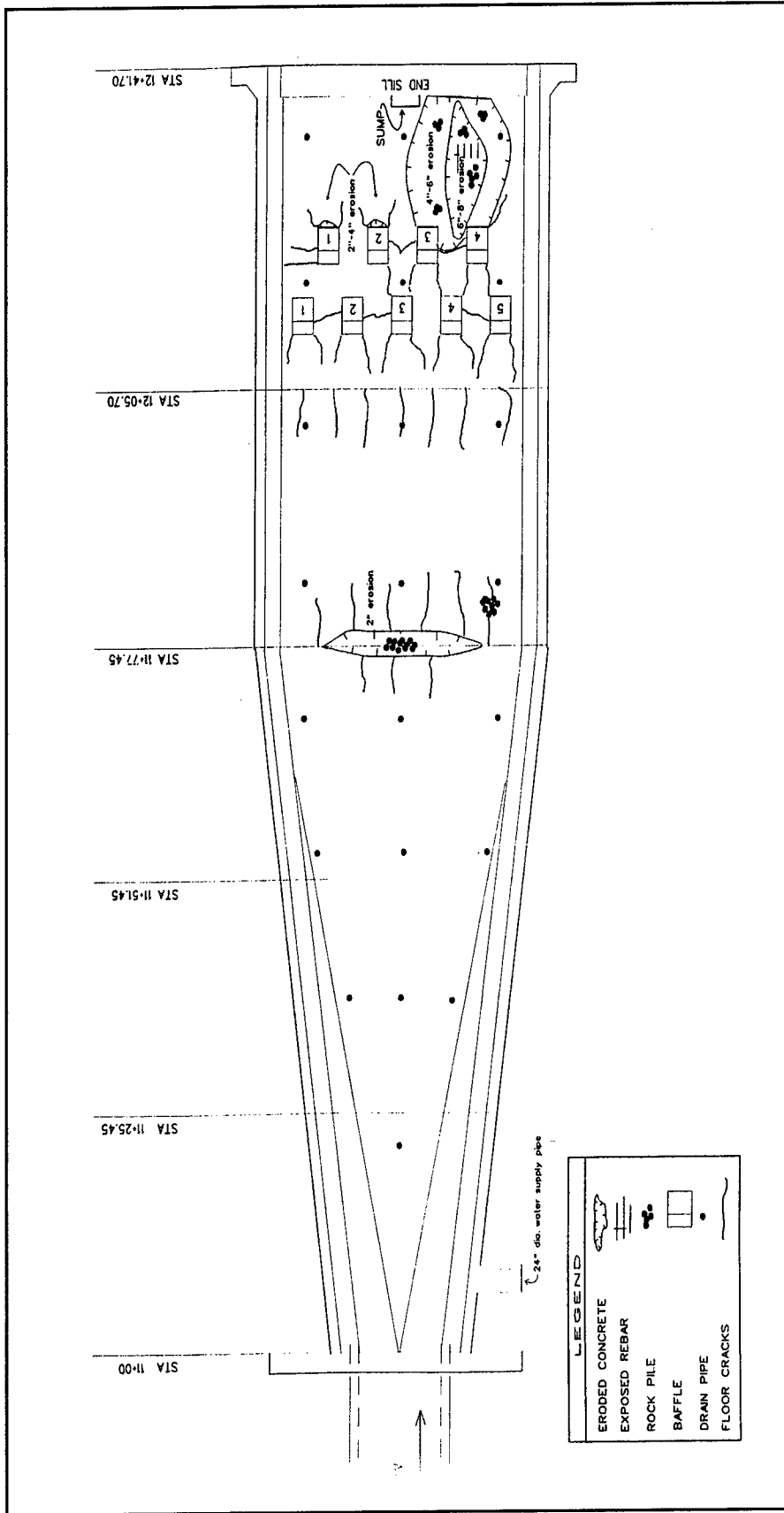

Figure 85. Erosion damage in stilling basin, Gilliam Lake Dam (from U.S. Army Engineer District, Little Rock 1997b)



extended into this area. (The roadway cantilevers 3.4 m (11 ft).) The cantilevered roadway area contained reinforcing steel, whereas the noncantilevered roadway area was not reinforced; however, no as-built drawings could be found to confirm that the reinforcing bars holding the cantilevered portion of the dam roadway were embedded in concrete in all major stress points of the dam roadway.

An examination of concrete cores taken from the roadway indicated that the cracks were more severe than surface cracks. A stability analysis, assuming a cracked section and neglecting concrete tension, indicated an unstable condition of the cantilevered portion of the roadway with the absence of reinforcement in the noncantilevered roadway portion of the dam.

In 1982, the concrete in the roadway on top of the nonoverflow monoliths was reinforced by retrofitting and posttensioning 25-mm- (1-in.-) diam steel rods on 1.8-m (6-ft) centers, transverse to the roadway cracks, in each of 38 monoliths (Figure 86). After installation of stress rods, 76-mm (3-in.) holes were drilled through the top of the dam monoliths and then grouted. The cantilevered portion of the dam roadway was reinforced with special strength 581-mm (2-in.) reinforcing bars. A 152-mm (6-in.) hole was drilled through the 12.2-m (40-ft) roadway of the dam; the reinforcing bar with a threaded end was inserted through the hole and tensioned with 550 MPa (80,000 psi). Nuts on the end of the reinforcing bar were tightened down on steel washers. The hole was grouted with high-strength grout, and the cavity for the nut and washer on each end of the reinforcing bar was concreted over. These reinforcing bars were placed every 6 m (20 ft). In 1983, the roadway cracks were sealed with a nonflexible epoxy. Cost of the repair was \$525,600.

The inspection team for the Fifth Periodic Inspection of Norfolk Dam had recommended reducing the inspection interval for the dam to every 3 years because of the abnormal cracks in the roadway cantilever and monolith cracks in the flood control conduit in Monolith 16 (USAED, Little Rock 1990). However, the team for the Eight Periodic Inspection reinstated the 5-year interval for inspections. In the interval between these inspections, the roadway cantilever had been reinforced and the roadway cracks had been sealed with a nonflexible epoxy. Also, joint meters placed across the major longitudinal crack through the sluice in Monolith 16 and monitored since 1983 indicated movements were cyclic and related to variation in temperature. A finite element structural analysis of Monolith 16, performed in 1984, showed that the monolith was structurally adequate. The USAED, Little Rock, agreed with the recommendation to increase the inspection interval to 5 years.

### **Wilbur D. Mills Dam**

Wilbur D. Mills Dam is located on the lower Arkansas River. It is also known as Dam No. 2 in the McClellan-Kerr Navigation System. The structure consists of a 527-m- (1,730-ft-) long spillway section, a 1,150-m- (3,773-ft-) long earthen embankment, and 1579-m- (5,180-ft-) long high-level overflow section. The dam is 16 m (52.4 ft) high.

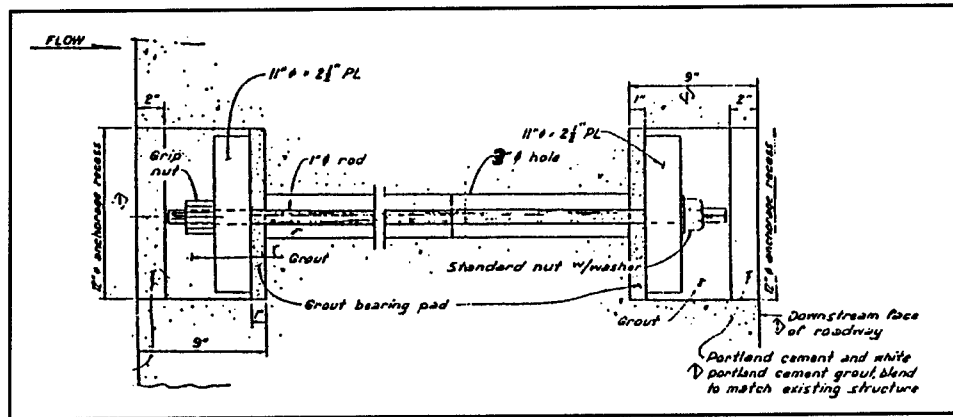

Figure 86. Steel rods used to reinforce cantilever portion of Norfolk Dam (multiply inches by 25.4 to obtain millimetres)

The Arkansas River flows into the Mississippi River. Flooding along the Arkansas River in December 1982, when the Mississippi River was low, created a situation of high water velocities in the Arkansas River and through the dam. The turbulent water caused 34 barges to break loose from a fleeting area 8 miles upstream of the dam. These loose barges caused the runaway of three others 8 km (5 miles) upstream of the dam. Fourteen of the barges struck the dam and sank wholly or partially and were wedged against the spillway gates; two passed through the open gate bays of the dam; the remaining twenty-one sank or grounded farther upstream (ASCE 1988).

The barges blocked 12 of the 16 gates of the dam and created upstream cross currents and downstream surging through the remaining 4 gates. These conditions resulted in severe scouring both upstream and downstream of the dam. Though the structure remained stable, there was concern that the severe scouring could result in undercutting and eventual failure of the dam. Immediate repair efforts included removing the barges and placing approximately 31,750 Mg (35,000 tons) of riprap in the downstream scour holes. Fine-grained material was dredged into the upstream scour holes to partially restore the upstream blanket.

In the latter part of the summer of 1982, work began on a permanent repair of the upstream scour area. This repair involved removing 1.2 to 1.5 m (4 to 5 ft) of the material that had been placed for the temporary repair and replacing it with 1,973 Mg (2,175 tons) of riprap. To prevent the riprap from being undermined by water currents, nearly 1530 cu m (2,000 cu yd) of concrete was pumped across the dam (335 m (1,100 ft)) to the scour area. The seal consisted of 0.5 to 0.6 m (1-1/2 to 2 ft) of concrete over the top of and slightly beyond the riprap. The cost of this repair was \$141,000 (Barber 1983).

In October 1990, work began on a permanent repair to the scour problem downstream of the dam. This repair involved the use of a novel concept (sunken barges filled with riprap) to extend the stilling basin 64 m (210 ft) downstream (Figure 87) (*Construction News* 1992).

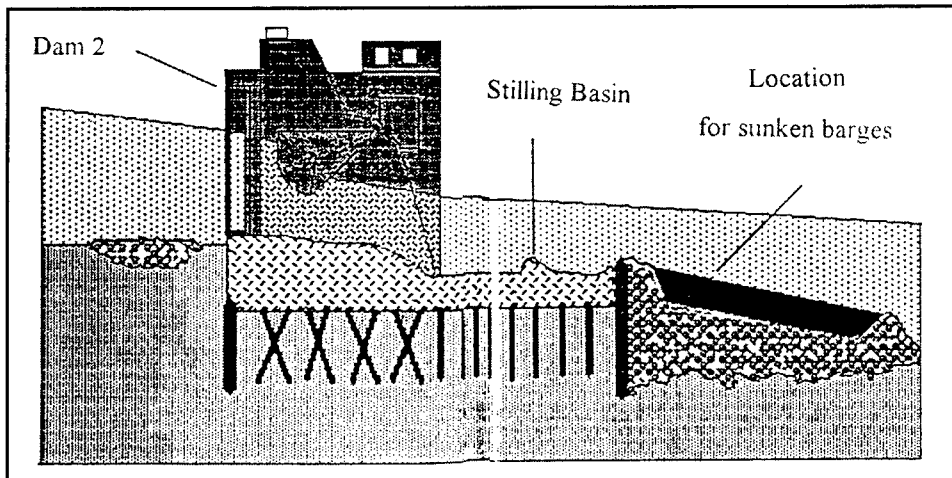

Figure 87. Repair stilling basin at Wilbur D. Mills Dam (from *Construction News* 1992)

Before the barges could be placed, the area had to be prepared. Since all of this work was done underwater, special equipment was needed. A German-made Liebherr excavator was the instrument selected. The excavator was mounted on a barge, which floated 15 to 18 m (50 to 60 ft) above the riverbed. Its electronic sensors and advanced computer technology tracked the underwater operations and provided the operator a graphic display on a monitor in the cab. A Set 3 Electronic Total Stationing surveying instrument was set atop the dam and used to precisely position the excavator barge. From the barge, the operator directed the removal of riprap weighing up to 4,080kg (9,000 lb) per stone and the proper sloping of the riverbed. Once this work was completed, a bed of leveling stone 0.3 to 0.6 m (1 to 2 ft) thick was placed and the bed resloped with a steel H-beam.

Once the riverbed was ready, the lay barge was constructed (Figure 88). Two rake barges were connected with two huge plate girders to form a giant catamaran. Cross-bracing and walkways between the barges were added. The space between the "pontoons" was 13 m (43 ft) wide, to allow positioning of the hopper barge for sinking. The flotation chambers of the hopper barge were filled with 650 cu m (850 cy yd) of concrete for a total weight of 1,451 Mg (1,600 tons). A tow boat then pushed the lay barge

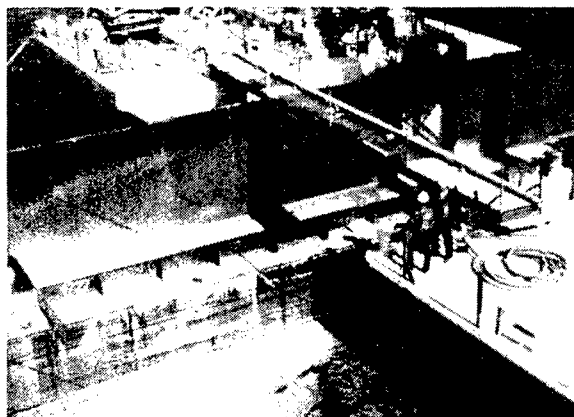

Figure 88. Lay barge with hopper barge positioned for sinking at Wilbur D. Mills Dam (from Spaul and Virden 1992)

into position below the dam. Anchor lines were moored to piles downstream of the dam and to the stern and bow of the lay barge. These lines were used to adjust the position of the hopper barge. When it was in the correct position, the hopper barge was sunk to the river bottom; the back of the barge was lowered so water could flood the cargo hole (Figure 89). The barge was then lowered to the bottom by four winches with 32-mm (1-1/4-in.) cables.

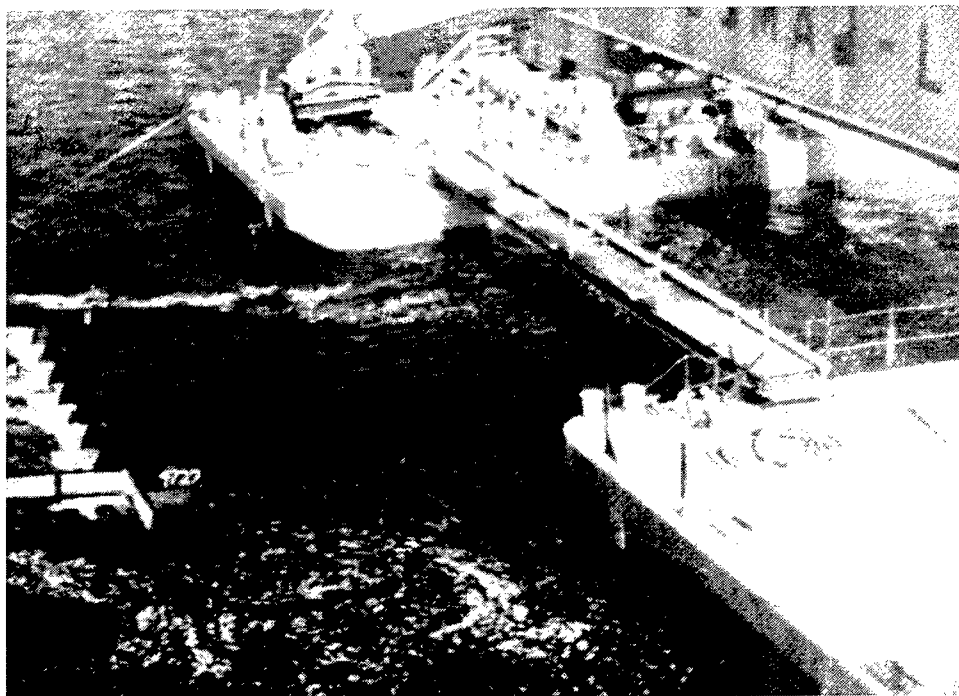

Figure 89. Lay barge with a flooded hopper barge being lowered to the river bed at Wilbur D. Mills Dam (from Spaul and Virden 1992)

After each hopper barge was sunk, its cargo hold was filled with rock, and an underwater concrete mixture was used to fill the voids in the rock-filled barge. This same concrete mixture was used to fill the spaces between the existing stilling basin upstream and the sunken barges.

Other work included placing riprap on both banks of the river for about 183 m (600 ft) downstream of the dam and in the river bottom for 47.7 m (150 ft) beyond the stilling basin extension.

The contract for the permanent repair was \$17.6 million, which was much less than the cost of other possible solutions (*Construction News* 1992).

## Bureau of Reclamation (BuRec)

### Arthur R. Bowman Dam

Arthur R. Bowman Dam is located on the Crooked River in central Oregon. It is a central-core rock-filled dam that stands 74.7 m (245 ft) high and is 235 m (800 ft long). A study determined that the probable maximum flood (PMF) would overtop the dam by 6 m (20 ft) with a discharge of 8 cms (280 cfs) over the embankment crest. Overtopping would start at 23 percent of the PMF, which corresponds to approximately the 500-year flood.

A decision was made to provide overtopping protection to the dam to accommodate large flood events. Although roller-compacted concrete (RCC) had become a common form of overtopping protection and had performed satisfactorily in several locations, BuRec designers were reluctant to use RCC at the A.R. Bowman Dam because it had not been used on dams with the hydraulic height and anticipated flow velocities of A.R. Bowman Dam. BuRec staff members evaluated case histories of overtopping protection for conventional spillway chutes that had failed in an effort to eliminate the potential failure in this project. The common element in the failed applications was that individual concrete slabs were lifted by uplift pressures from flow that was deflected through vertical offsets or contraction joints. The designers determined that almost any concrete overtopping overlay would be stable on the downstream face of a dam if there were no offsets or uplift along the flow surface.

Four concrete overtopping protection alternatives were evaluated: RCC overlay with steps, RCC without steps, continuously reinforced concrete (CRC) overlay with steps, and a smooth CRC slab. The CRC slab was chosen because it would provide monolithic behavior, creating a nearly impervious barrier without protrusions into the flow. Also, conceptual design cost estimates revealed the smooth CRC slab to be the most economical.

Specifications called for the slab to be 305 mm (12 in.) thick. Since the slab would provide its own crack control and a layer of crushed rock under the slab would provide drainage, there was no need to increase the thickness of the slab. Three weep holes at the toe of the dam were installed to allow for drainage. To prevent a back flow of water into the weep holes from hydraulic jump pressures, the weep holes were fitted with flap valves.

The crest of the dam was designed to prevent seepage under the CRC overlay. A drainage blanket that drains through the downstream crest block was placed under the crest overlay. Upstream and downstream wedge-shaped blocks embedded in impervious zone 1 material prevent seepage from the upstream face and through the road. The CRC overlay is anchored into the downstream wedge block.

Groin protection was provided by anchoring the CRC slab into the abutment bedrock and lining the abutments with concrete in those areas where the bedrock

was considered to be susceptible to erosion. Also, the abutments were shaped to provide smooth flow lines to reduce turbulence along the groins (Hensley and Hennig 1991).

### **Cottonwood Dam No. 5**

Cottonwood Dam No. 5 is one of 17 small private reservoirs that were constructed on Grand Mesa, near Grand Junction, Colorado, to regulate spring runoff of small streams. They have since been incorporated in the Collbran Project to provide water for irrigation and hydroelectric power. Following a safety inspection, in the early 1980s, a recommendation was made that Cottonwood Dam No. 5 be breached and reconstructed. This recommendation provided the BuRec the opportunity to field test the use of a flexible membrane lining as a low-cost means of constructing a spillway.

Growing concern over inadequate emergency spillway capacity for embankment dams led the BuRec to begin a search for low-cost alternatives to meet new inflow requirements. One alternative that appeared to have merit was the use of a buried, flexible membrane to line an emergency/auxiliary spillway. Although a search of literature produced no reports of the use of flexible membranes for spillway embankments, one report mentioned that work was being done in France, and another from the U.S.S.R. concluded that soft spillways should be studied further. Selection of a project for field testing was based in part on the consequences of failure and the feasibility of the test area.

The main objective of the field test at Cottonwood Dam No. 5 was to develop design procedures, material specifications, construction procedures, and cost data for use of membranes in spillways of low-head structures.

Before the emergency spillway was constructed, the earth dam was rebuilt 6 m (20 ft) high and 137 m (450 ft) wide. The spillway was aligned to pass through the more plastic materials on the right abutment to provide additional erosion protection if needed. Prior to installation of the membrane, the spillway subgrade was inspected to ensure that it was free of depressions, wet areas, or any objects that could puncture the lining. The membrane used was 36-mil reinforced hypalon sheets fabricated to 11.6 by 12.2 m (38 by 40 ft) and 11.6 by 7 m (38 by 23 ft). During shipment and storage the lining was protected from direct sunlight, temperatures greater than 60 °C (140 °F), and debris. At the job site, the membrane remained in a heavy-duty protective covering until it was installed (Timblin et al. 1984).

The membrane sheets were anchored and installed in the spillway in a slackened condition, with a 1.5-m (5-ft) overlap of each sheet at its downstream end. The sheets were fabricated to span the entire width of the spillway to prevent the necessity for splicing. A concrete grade sill was installed at the upper end of the liner system to prevent piping. A membrane sheet was attached to the grade sill with redwood furring strips and nails to prevent separation and to distribute load evenly across the sheet. Subsequent downstream sheets were

anchored at their upstream end and at their edges by tucking the ends into trenches and compacting backfill into the trenches. A 80-m- (262-ft-) long section of the spillway was lined with membrane sheets in this fashion. A concrete grade sill was also installed at the downstream end of the membrane system to protect against headcutting. The entire lined area was covered with 152 mm (6 in.) of granular material to provide protection against puncture from animals and vehicle traffic. At the beginning of emergency spillway operation, this granular material will be washed away and the membrane lining system will provide protection from erosion.

The finished design included an inflow design flood of 100 years and a discharge of 1.1 cms (40 cfs), with supercritical flow over the entire area protected by the liner. Channel dimensions following installation of the liner were a depth of 0.9 m (3 ft), a width of 3.7 m (12 ft), and a 2:1 side slope. The maximum channel velocity was 4.4 m (14.5 ft) over a naturally incurred hydraulic jump downstream of the riprap area. The project was completed in 1985 (Parrett 1986).

### **Friant Dam**

Friant Dam is located 32 km (20 miles) north of Fresno, CA. The 97-m- (318-ft-) high dam impounds the 642,000,000-cu m (520,470 acre-ft) Millerton Reservoir, which provides water for domestic use and irrigation. Three 5.5-m- (18-ft-) high by 30-m- (100-ft-) long drum gates were used to control reservoir discharge. Spillway capacity is 2,350 cms (82,980 cfs).

Alkali-aggregate reaction caused the expansion of the concrete at the outermost piers of the downstream face of the dam (Figure 90). The expansion caused binding of the drum gates, thus affecting operation of the dam.

Following a 1992 study, the U.S. Bureau of Reclamation, owner of the dam, decided to replace the outer drum gates with rubber dams and rehabilitate the inner drum gate. Further studies were implemented. In 1997, BuRec decided to use the Obermeyer Pneumatic Spillway Gate System to replace the two outer drum gates. This system consists of high-strength steel gate panels connected to the spillway crest with a pivotal, reinforced elastomeric hinge. Inflatable actuators clamped along the hinge sections within an embedded keyway in the spillway concrete are used to operate the gates. This system provides a leak-proof connection.

The Obermeyer Pneumatic Spillway Gate System planned for installation at Friant Dam was being designed to match the curvature of the existing lowered drum gates (Figure 91). The project was scheduled to be completed in February 1998.

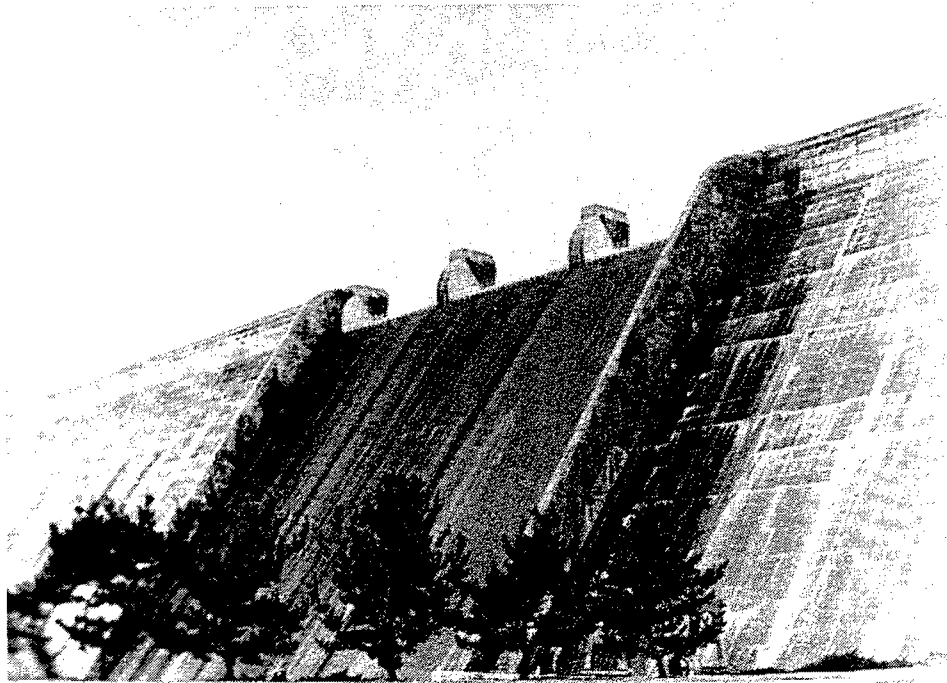

Figure 90. Alkali-aggregate extrusion on the downstream face of Friant Dam  
(from *Hydro Power and Dams* 1997)

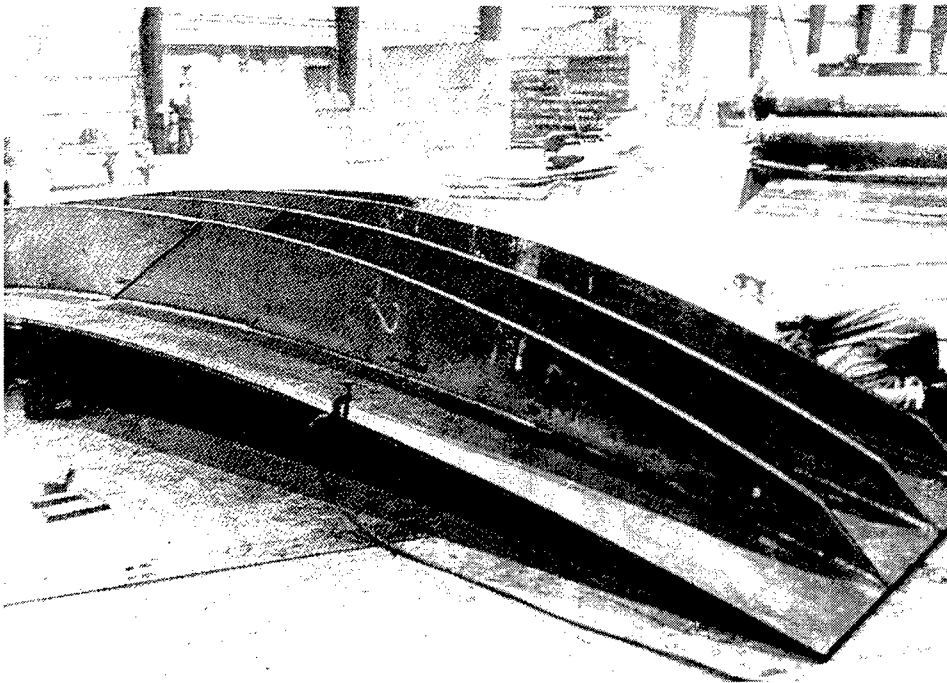

Figure 91. Fabrication of Obermeyer Pneumatic Spillway Gates for installation  
at Friant Dam (from *Hydro Power and Dam* 1997)



## Gibson Dam

Gibson Dam (Figure 92) is located in a narrow gorge of Montana's Sun River, about 112 km (70 miles) west of Great Falls. The 60.6-m- (199-ft-) high concrete arch dam is controlled by the BuRec. In 1964, a storm overtopped the 37-year-old structure for approximately 20 hr with 1 m (3.2 ft) of flow over the top of the parapet wall. Although no substantial damage was detected, BuRec reevaluated the PMF, raising the peak discharge from 1,700 to 4,400 cms (60,000 to 155,000 cfs). BuRec decided to rehabilitate the dam in 1980-82 to meet a new PMF volume of 45,022,750 cu m (365,000 acre-ft). During this maximum flood, the dam would be overtopped by 3.7 m (12 ft) for approximately 5 days.



Figure 92. Gibson Dam following rehabilitation and construction of splitter piers (from Parrett 1986)

In a new approach, piers were constructed on the crest of the dam. In the event of overtopping, the piers will divide the flow and provide aeration beneath it. The piers extend to the height of the PMF (3.7 m (12 ft)) and are placed at intervals of 30.5 m (100 ft). The upstream pier edges project into the roadway, and the downstream edges are flush with the parapet walls. To prevent plucking erosion, rock bolts and concrete caps were installed on downstream rock abutments (Parrett 1986).

## Glen Canyon Dam

Glen Canyon Dam is located on the Colorado River 24 km (15 miles) upstream of Lee's Ferry, Arizona. The dam, which is controlled by the BuRec, was completed in 1964 as a part of the Colorado River Storage Project. The 216-m- (710-ft-) high concrete arch dam has two open-channel-flow-type-spillway tunnels regulated by 12.2 by 16 m (40- by 52.5-ft) radial gates. Each tunnel has a 12.5-m- (41-ft-) diam section inclined at 0.96 radians (55 deg), a vertical elbow, and a 3,048-m (1,000-ft) horizontal section with a deflector bucket at the end. The reservoir provides 33,304,500 cu m (27,000,000 acre-ft) of storage.

After 16 years, it was finally filled, and the spillway system was tested for the first time in July 1980. An inspection of the tunnels following the test revealed minor cavitation damage to the liners. (Vapor cavities occur in a liquid when water pressure in a high-velocity flow is reduced by an irregularity in the flow surface. As these cavities move into a zone of higher pressure, they collapse, sending out high-pressure shock waves that cause cavitation.)

After analyzing the spillway flow, BuRec staff members decided to construct an aeration slot in each tunnel. These slots, which would be based on the design of similar slots used at Yellowtail Dam in southern Montana, would entrain air into flowing water to significantly reduce the effect of collapsing vapor bubbles. The necessary field data to begin the aeration-slot design had been gathered when a major flood event occurred in 1983. The flood was caused by snow melt from an extremely large snow pack. Burgi and Eckley (1987) described the Glen Canyon aeration-slot project; this case history is a summary of their report.

BuRec made every effort to control the flow through the tunnels to minimize damage, especially in the right tunnel, after a June 6 inspection in which engineers found several large holes in the invert of the elbow of the left tunnel. To provide additional storage in Lake Powell and continue controlled releases through the spillway, 2.4-m- (8-ft-) high metal flash boards were installed on top of the spillway gates. These flash boards also proved useful after the peak inflow had passed and the gates could be closed. However, during the flood, both spillway tunnels had to be used for two months. As a result, major damage occurred in the elbows of both spillway tunnels.

The tunnel spillways were dewatered in early August 1983. Engineers, who entered the tunnels through the deflector buckets, found approximately 229 cu m (300 cy yd) of concrete, reinforcing steel, and sandstone in the deflector bucket of the left tunnel. They discovered a large sandstone boulder in the tunnel invert and debris several feet deep along the invert. Immediately downstream from the elbow in the left tunnel, a hole 10.7 m (35 ft) deep, 40.8 m (34 ft) long, and 15.2 m (50 ft) wide (Figure 93) had been eroded in the sandstone by the high-energy spillway flow. Most of the tunnel liner circumference was missing in the area of the hole. The right tunnel spillway was less severely damaged; however, there was a large hole in the tunnel invert immediately downstream of the elbow.



Figure 93. Cavitation damage downstream of the elbow in the left spillway elbow at Glen Canyon (from Burgi and Eckley 1987)

The invert liner was missing for some 53 m (175 ft), and sandstone had been excavated up to 3.7 m (12 ft) deep.

In late August 1983, BuRec contracted for the repair work and the installation of an aeration slot in each tunnel. Work in the project was performed in several stages: first, holes downstream of the elbows were backfilled, and then major damage in the elbows was repaired. Less severe damage to the inverts was ground and patched; sandstone erosion downstream to the deflector bucket was repaired. The final phase of the project was to install the aeration slots.

Throughout the repair effort, care had to be taken to direct all flowing water from seepage, drain holes, and radial gate leakage around the work area. Access had to be provided and demolition had to be controlled to prevent the destruction of the sound portions of the tunnels.

Dewatering the structure included caulking radial gates and redirecting remaining leakage around the work site. In the tunnel, packers were installed in the crown drain holes, and polyvinyl chloride (PVC) drainage pipes were used to route water to the elbow area. French drains, ditches, steel panning, reinforced rubber and neoprene conveyor belting, and plastic sheeting supported by chain-link fencing or wooden trusses were also used to control water.

To provide access to the nearly horizontal portion of each tunnel, workers constructed two horseshoe-shaped tunnels from the power plant parking lot to the spillway tunnels. The inclined portion of each spillway was reached from the spillway radial gate intake structure via hoists, suspended walking platforms, and an eight-passenger mancar. Workers and equipment were transported to the aeration-slot installation area by a hoist and man-car system.

Repair work began with the removal of the entire tunnel lining, including sections that were not damaged, to improve safety, speed construction, and produce satisfactory, long-lasting results. The tunnel was rewatered for this work, which was performed from platforms on barges. Once the lining was removed, the tunnel was dewatered for the second time, the debris from the demolition process was removed, and repair of reinforcement began. Damaged and missing reinforcement was replaced (Figure 94). New reinforcement was manually welded to existing reinforcement in most cases. In areas where drainage water prevented welding, steel dowels were epoxied into drill holes in the liner and then wired to the existing reinforcing in a splicing technique.

Backfilling the large scour holes downstream of the tunnel elbows required 1,760 cu m (2,300 cu yd) of concrete for the left tunnel and 523 cu m (684 cu yd) for the right. Minimum compressive strength specified for the concrete was 17.2 MPa (2,500 psi). Transit mixers were used to accomplish the monolithic placement of the backfill. No. 11 steel bars used for scaffolding were left in place as the only reinforcing.

A 1.22-radian (70-deg) invert screed on rails was used to place the tunnel invert once reinforcement for the invert had been constructed. Concrete was transferred to the screed through a hopper and conveyor system. As the screed moved along, the concrete was vibrated through the hoppers and under the screed.

The arch lining in the severely damaged section was reinforced with a double mat of No. 11 reinforcement on 152-mm (6-in.) centers. Concrete was placed from the upstream direction with a form system fed by four 203-mm (8-in.) slick lines. Concrete with a 101-mm (4-in.) slump was used for the lower portion of the placement and with a 152-mm (6-in.) slump for the crown. Concrete was pumped to refusal.



Figure 94. Steel reinforcing steel being replaced in the invert of the spillway elbow at Glen Canyon (from Burgi and Eckley 1987)

Damage in the elbows of the tunnels occurred mainly in the floor with holes approximately 2.4 m (8 ft) deep in a stair-step fashion. The steps in this area were removed by drilling and blasting. The edges of the the damaged area were sawcut, and concrete below the first mat of steel was removed. Damaged reinforcing was replaced. Concrete on the steeper portions of the spillway elbow were replaced with a standard screed and strike-off. . The areas of erosion downstream of the deflector bucket were repaired with tremie concrete placed from floating barges. Approximately 1,530 cu m (2,000 cu yd) of concrete was placed in this area.

Although tunnel lining and invert replacement were made to the same line and grade and the same reinforcing as used in the original construction, BuRec criteria for damage repairs were not as extensive as those previously required on similar rehabilitation work. Since the repaired tunnels would include an aeration slot to prevent cavitation damage, BuRec decided the tunnel lining did not have to be as smooth as would have been required otherwise. A savings of several million dollars was realized by this relaxing of the smoothness criterion.

The aeration-slot design for Glen Canyon Dam consists of a short length of ramp that lifts the flowing water over the air supply slot to prevent the slot from filling with water (Figure 95). The slot, which is 1.2 by 1.2 m (4 by 4 ft) in cross section, extends around the lower three-quarters of the tunnel. It is located on the 0.96 radians (55 deg) incline approximately 45.7 m (150 ft) above the start of the elbow and just below the 178-mm- (7-in.-) high ramp. The ramp is designed to create a low-pressure zone under the water jet which draws air into both sides of the slot from the tunnel above the water surface. The air drawn under the water jet is concentrated in the lower surface of the jet nappe and flows along the boundary through the elbow.

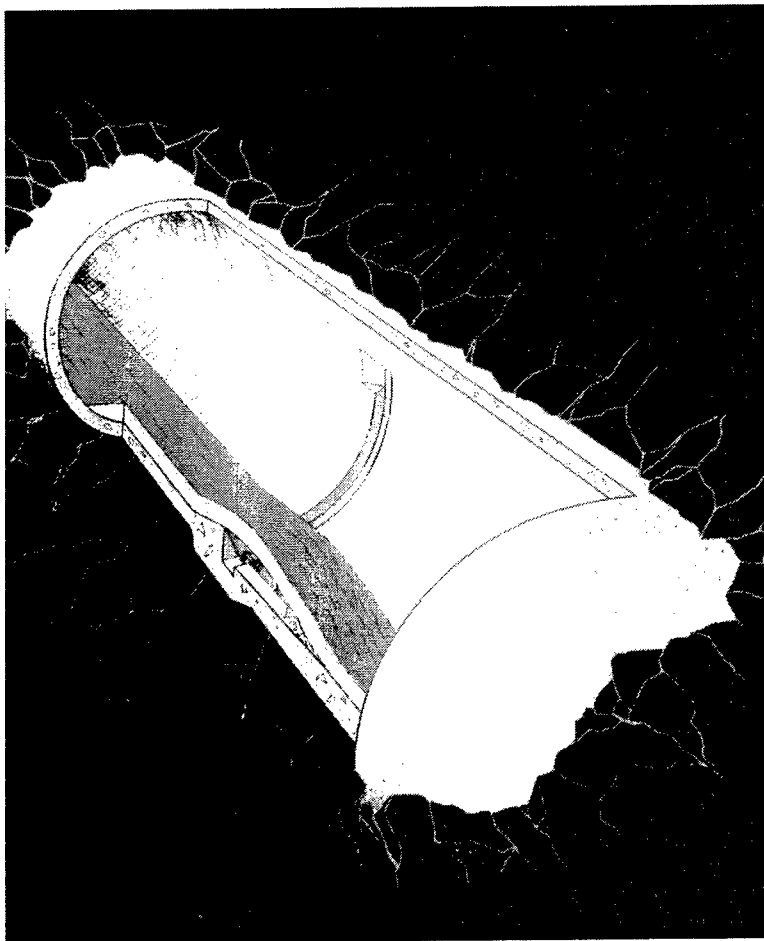

Figure 95. Aeration slot, Glen Canyon Dam (from Burgi and Eckley 1987)

Construction of the aeration slots was made difficult by access restrictions, the wet work environment, and limited space. Concrete removal for the aeration slots was accomplished by saw cutting, drilling, and blasting. Installation of each slot required replacement of 8.8 lin m (29 lin ft) of the sloping tunnel liner. Approximately 535 cu m (700 cu yd) of concrete was placed per slot. The concrete was pumped into hoppers at the spillway bridge and gravity fed down a 76.2-m (250-ft) line to the placement area. Placement was made from downstream to upstream.

Prototype tests on the rehabilitated left tunnel were run from 11 to 17 August 1984 to evaluate the design of the slots. Computer-based instrumentation installed in the slots collected air velocity, dynamic pressure, and static pressure. Following the phase one basic data-gathering tests, the tunnel was tested under conditions that would have induced cavitation without the existence of the slot; only minor concrete deterioration was found--none due to cavitation. Cost of the repair was approximately \$31 million.

### **Grand Coulee Dam**

Grand Coulee Dam is located on the Columbia River in northeast Washington. Completed in 1942 as a part of the BuRec's Columbia Basin Project, it forms the 82 km- (51-mile-) long Franklin D. Roosevelt Lake Reservoir. The dam provides hydroelectric capability of over 6,000,000 kW, and the reservoir is an integral part of an irrigation system for over 4,046,900,000 sq m (1 million acres) of land in the Columbia Basin area. A two-lane concrete roadway, over 1.6 km (1 mile) long and 457 mm (18 in.) thick, was constructed directly on the top of the mass concrete of the dam. After 45 years of use and exposure to severe winter conditions, the roadway experienced shallow spalling and surface cracking. The deterioration was not a threat to the safety of the dam, but if it was not repaired, the roadway would eventually have to be replaced.

A conventional asphalt overlay was not a repair option because the roadway contains numerous hatches, access ports, electrical service outlets and the embedded rails for the dam's gantry cranes; the clearance between the crane wheels and the roadway concrete is less than 19 mm (3/4 in.). BuRec selected a surface-impregnation technique for the repair.

BuRec had begun investigating and developing concrete polymer materials in 1966 in the belief that these materials could be used to reduce the permeability of concrete and, therefore, the deterioration caused by chloride intrusion, whether the intrusion resulted from the use of chloride deicing salts on highways and highway bridge decks in areas affected by sub-freezing weather or from windblown sea spray in coastal areas. A cooperative research program sponsored by the Federal Highway Administration and performed at BuRec facilities indicated that impregnating the surface of concrete bridge decks to a depth of 12.7 to 25 mm (½ to 1 in.) with acrylic polymer would increase the durability of the bridge decks. Following the initial study, surface impregnation was demonstrated on highway bridge decks in eight states, the largest application

being the impregnation of the entire roadway and part of the pumping plant parking area of Grand Coulee Dam. A contract for the work was awarded under competitive bidding procedures. The construction period was from May to December 1982. W.G. Smoak (1990) reported on the project; this case study is a summary of his report.

Traffic over the roadway was limited to one lane during surface impregnation. The contractor elected a 24-hr-a-day work schedule, with exceptions for special holidays or events when full access to the dam roadway was required.

The first step was to sandblast the concrete surface to remove contaminants and shallow areas of deterioration. Then thermocouples were epoxied to the surface and at depths of 25 mm (1 in.) below the surface to monitor the temperature of the concrete.

The contractor used a 4.6 by 79-m (15- by 260-ft) heating enclosure for drying, impregnation, and polymerization. The enclosure had a structural steel channel base covered with 22 heating panels, each containing nine electric infrared heating elements. Three heat-control units with timers were used to regulate the temperature for each process.

Before the drying process was begun, a 12.7-mm- (1/2-in.-) thick layer of sand was spread on the concrete surface within the enclosure to reduce thermal shock to the concrete and to serve as a reservoir for the monomer system while it penetrated the concrete surface. Then the heat panels were set in place and connected to the electricity. Typically, the drying cycle required 14 to 16 hr; heat had to be maintained at 121 °C (250 °F) for 8 hr. Then followed a cool-down period of 12 to 36 hr, depending on how long it took for the concrete 25 mm (1 in.) below the surface to reach 37.8 °C (100 °F).

The next step involved impregnation of the concrete. The monomer system was 95-percent methyl methacrylate (MMA) and 5 percent trimethylpropane trimethacrylate (TMPTMA) with 0.5 to 1.0 percent AMVN (2,2-azobis-(2,4-dimethylvaleronitrile)), a polymerization catalyst, all by mass. The system was applied at the rate of 2 kg/sq m (0.4 lb/sq ft) with a hand-held sprayer attached to the monomer tank truck with a flexible hose. Immediately following application of the monomer, mylar film was placed over the saturated sand, where it would remain through polymerization. The mylar film reduced monomer evaporation and fire hazard within the enclosure. Impregnation required about 6 hr. During this time, the heat panels were replaced, and the enclosure was prepared for the polymerization step.

The polymerization step involved reheating the pavement and then maintaining a temperature of 73.9 °C (165 °F) for 5 hr. A total reheat-polymerization cycle required 7 to 8 hr. A forced-air ventilation system with monomer vapor sensors in the enclosure was used to prevent development of flammable and unsafe vapor concentrations. This process resulted in polymer penetrations of 12.7 mm (1/2 in.).



The complete three-step process could be completed in about 48 hr. Fifty setups of the enclosure were required for the entire project. Seven years after completion of the project, no further damage to the concrete surface of the roadway had been noted.

The cost of the treatment of the roadway was \$42.37 per 0.8 sq m (1 sq yd); this cost did not include electricity used for the drying and polymerization steps or the impregnation sand.

Polymer impregnation appears to be a very effective method of increasing the impermeability of concrete surfaces and making them more abrasion resistant. The surface impregnation process can be used on precast or cast-in-place concrete, and it requires very simple equipment. However, the process has limitations. The monomer would be difficult to apply to any surface that is not horizontal because the material has to soak into the concrete. Also, safety is a factor that should be considered carefully: the MMA-TMPTMA monomer system is flammable and has a moderately high vapor pressure. The flash point of the monomer is 12.8 °C (55 °F), and the vapors of the monomer and catalyst are toxic. Storage, handling, and use of these materials must be done in compliance with established safety practices.

### **Stewart Mountain Dam**

Stewart Mountain Dam is located on Salt River just west of Phoenix, AZ. The dam, which was completed in 1930, was constructed as a part of a water storage, supply, and power plant system by the Salt River Valley Water Users Association. The thin arch dam is 65 m (212 ft) high and 178 m (583 ft) long; it is 2.4 m (8 ft) wide at the crest and 10 m (33 ft) wide at the base. A gravity-type thrust block and a gravity-type wing dam connect the arch dam to the abutments on each side. The service spillway is located on the right abutment, and the auxiliary spillway, on the left (Figure 96).

Structural stability investigations conducted by the BuRec in the late 1960s, indicated Stewart Mountain Dam was not stable enough to survive the revised maximum credible earthquake (MCE), Richter magnitude of 6.75 at 15 km (9.3 miles). The stability of the dam was questioned because of poor bond of the horizontal construction joints, deterioration of surface concrete, a 152-mm (6-in.) displacement of the arch crest, and revised PMF loads, which indicated the dam would be overtopped by 4.3 m (14 ft). The poor bond between the 1.5-m- (5-ft-) high concrete blocks of the dam was attributed to ineffective clean-up between placements during construction and the use of concrete with relatively high water content to combat high ambient temperatures at the time of construction. Alkali-silica reacted concrete caused the surface deterioration and the displacement of the arch crest. A three-dimensional finite element analysis of the dam under PME seismic loading conditions indicated there could be separation of lift joints which could cause failure of the dam (Nuss and Fielder 1988).

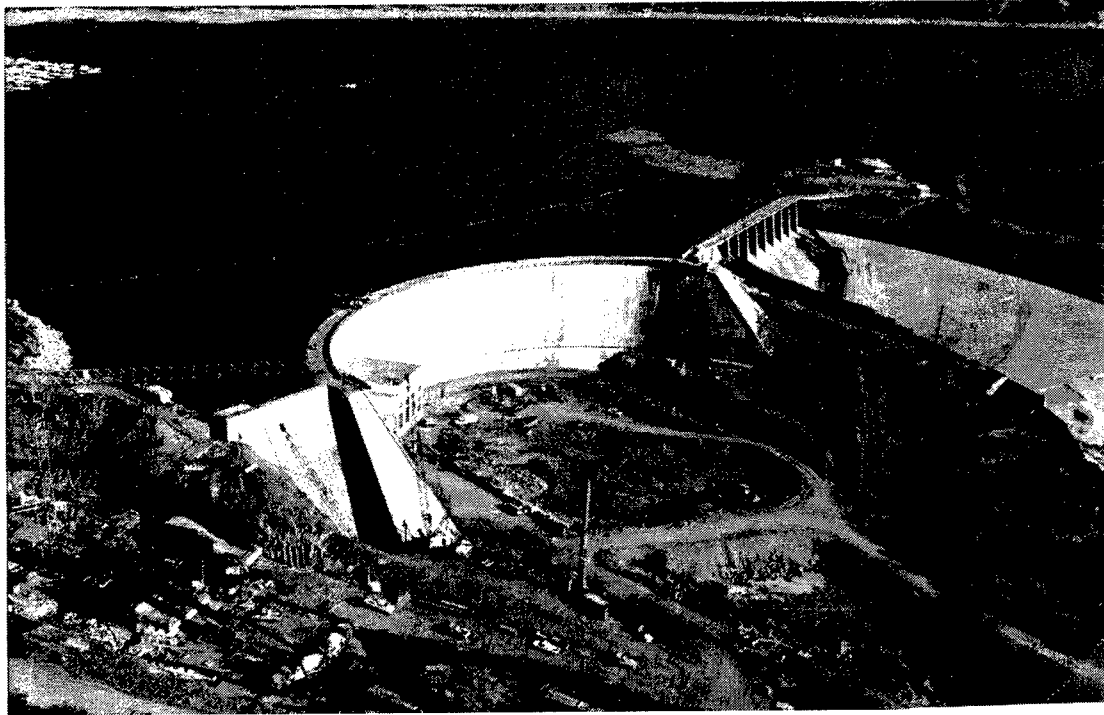

Figure 96. Overview of Stewart Mountain Dam (from Bruce, Fielder, and Triplett 1991)

After further study, BuRec decided to construct an auxiliary spillway to alleviate the PMF loading and to stabilize the dam against possible seismic loadings with posttensioned rock anchors. Posttensioned anchors had been used to stabilize concrete gravity dams, but this was believed to be the first time this method was used to stabilize a thin arch concrete dam (Nuss and Fielder 1988).

A geological investigation of the foundation of the arch dam indicated the bed rock had three distinct zones, each with its own mechanical properties, fracture systems, and permeabilities. Test of the design anchors indicated they would have high safety factors in two of the zones. Design specifications for anchors to be used in the third zone were altered (Bianchi and Bruce 1993).

A preliminary investigation indicated that the concrete, although cracked, had more than enough strength and stiffness to support the usual load combinations. After 1968, the permanent upstream displacement of the arch decreased, indicating the expansion due to alkali-silica reaction was slowing down. Also, the interior concrete showed trends of healing and gaining strength. Future expansions from alkali-silica reactions were judged to be minor and not detrimental to the structure due to a depletion of reactive alkalis in the concrete.

The installation of posttensioned cables was judged to be the least expensive, most viable solution for stabilizing the arch dam. Sixty-two tendons with free lengths ranging up to 65.8 m (216 ft) and bond lengths in the foundation from 9 to 13.7 m (30 to 45-ft) were installed on approximately 2.7-m (9-ft) centers (Figure 97). Each arched tendon was made up of 22 (152-mm- (0.6-in.-) diam)

epoxy-coated strands (Figure 98). Design working loads averaged approximately 2,958 kN (665 kips), the equivalent of about 50 percent guaranteed ultimate tensile strength (GUTS).

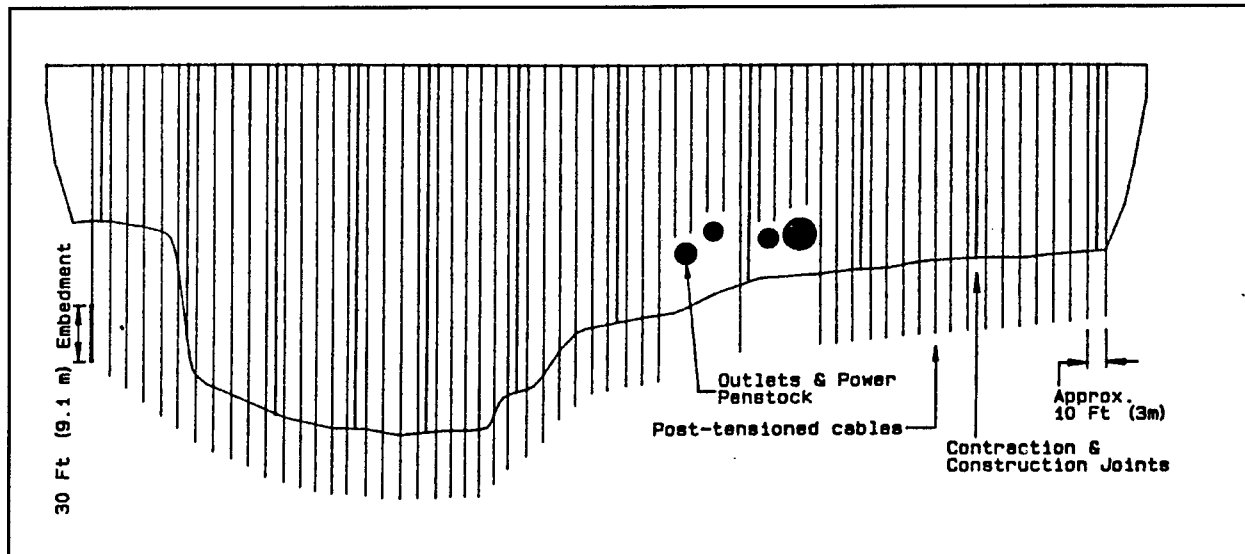

Figure 97. Profile Stewart Mountain Dam, showing locations of posttensioned tendons (from Nuss and Fielder 1988)

The effect of cable loads is different for arch dams than for gravity dams. Arch dams interact with load in a 3-D manner because of the horizontal and vertical curved shape. The cable force at Stewart Mountain Dam mainly compresses the structure in the vertical direction, to increase friction between lift joints, because the largest component is vertical. However, horizontal stresses develop in the arch because of arching action and the small radial component from the inclined cables.

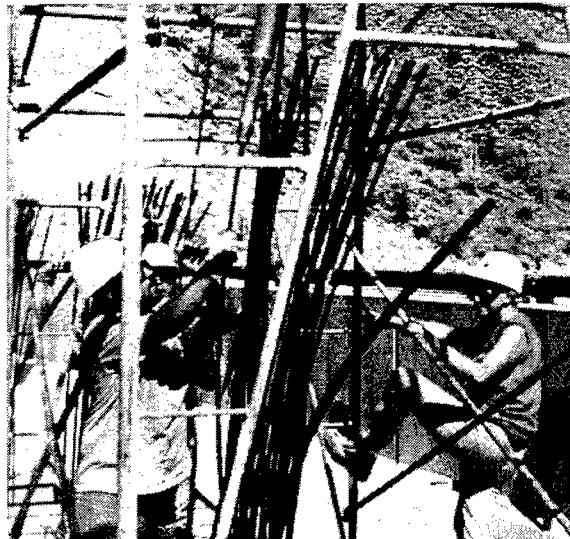

Figure 98. Arched tendons used to stabilize Stewart Mountain Dam (from Bruce, Fielder, and Triplett 1991)

The curved thin arch shape of the dam required precise positioning of the posttensioned cables (inclination varied from vertical to 0.15 radians (8 deg, 40 min) from vertical). Square recesses (1.4 by 0.6 m (4-ft, 9-in. by 2-ft) deep) were formed in the dam crest. At precise locations, bearing and inclination, a 305-mm- (12-in.-) diam hole was drilled about 1.5 m (5 ft) deep. A 254-mm- (10-in.-) diam steel guide tube was then surveyed and cemented into this hole to ensure the anchor-hole drilling

would have the exact prescribed starting orientation. A down-the-hole hammer was used to drill the 254-mm- (10-in-) diam anchor holes. A special hammer and rod attachments promoted hole straightness. During the drilling, the position of each hole was measured at 3-m (10-ft) intervals in the upper 15 m (50 ft) and every 6 m (20 ft) thereafter to final depth. The precision required for each hole was 76 mm (3 in.) in 30.4 m (100 ft).

After drilling, every hole was water-pressure tested, pregrouted, and redrilled if necessary. Some holes required three treatments to meet the specified 0.25 tpm/m (0.02 gpm/ft) of hole at 0.03 MPa (5 psi) excess pressure for the free length and half that for the bond length.

The epoxy-coated strands for the tendons were delivered to the site on special uncoilers. Workers used extreme care to prevent abrasion of the epoxy coating when they installed the tendons in the holes. A special high-strength, plasticized grout was tremied into each hole to provide the exact bond length.

Stressing was begun a minimum of 14 days after the grout was placed. Anchors were tested according to Post-Tensioning Institute (PTI) proof test provisions. Each anchor was proved to 133 percent of design working load (DL), prior to interim lock-off at 117 percent of DL. Monitoring of the dam during stressing confirmed no significant structural deflections. After a 100-day observation period, final lock-off at 108.5 percent of DL and full secondary grouting of the free length were performed.

In addition to the arch tendons, 22 tendons were installed in the left thrust block of the dam near the structure-foundation interface. These tendons, each of which had 28 strands, had a free length from 12 to 38 m (40 to 125 ft), plus a 12 m (40-ft) bond length. Design load for each tendon was 4,381 kN (985 kips), or 60 percent GUTS (Bruce, Fielder, and Triplett 1991).

## **Theodore Roosevelt Dam**

Theodore Roosevelt Dam was constructed between 1903 and 1911 at the confluence of Tonto Creek and Salt River, approximately 128 km (80 miles) northeast of Phoenix, AZ. The dam had an original structural height of 85.3 m (280 ft) and a crest length of 220 m (723 ft). It is the largest of the dams in the Salt River Project, which provides the area with hydroelectric power and water for irrigation and other municipal projects. When it was completed, it was the tallest cyclopean masonry, gravity-arch dam in the world.

Construction of the Salt River Project was the result of major policy by then President Theodore Roosevelt. The President, realizing westward development depended upon the availability of water and that the Federal Government was the only agency with resources sufficient for the project, persuaded Congress to pass the Reclamation Act of 1902, establishing the Reclamation Service, later named the Bureau of Reclamation. The following year, construction on

Theodore Roosevelt Dam began. In 1963, it was listed in the National Register of Historic Places (Figure 99) (Quint and Fielder 1989).

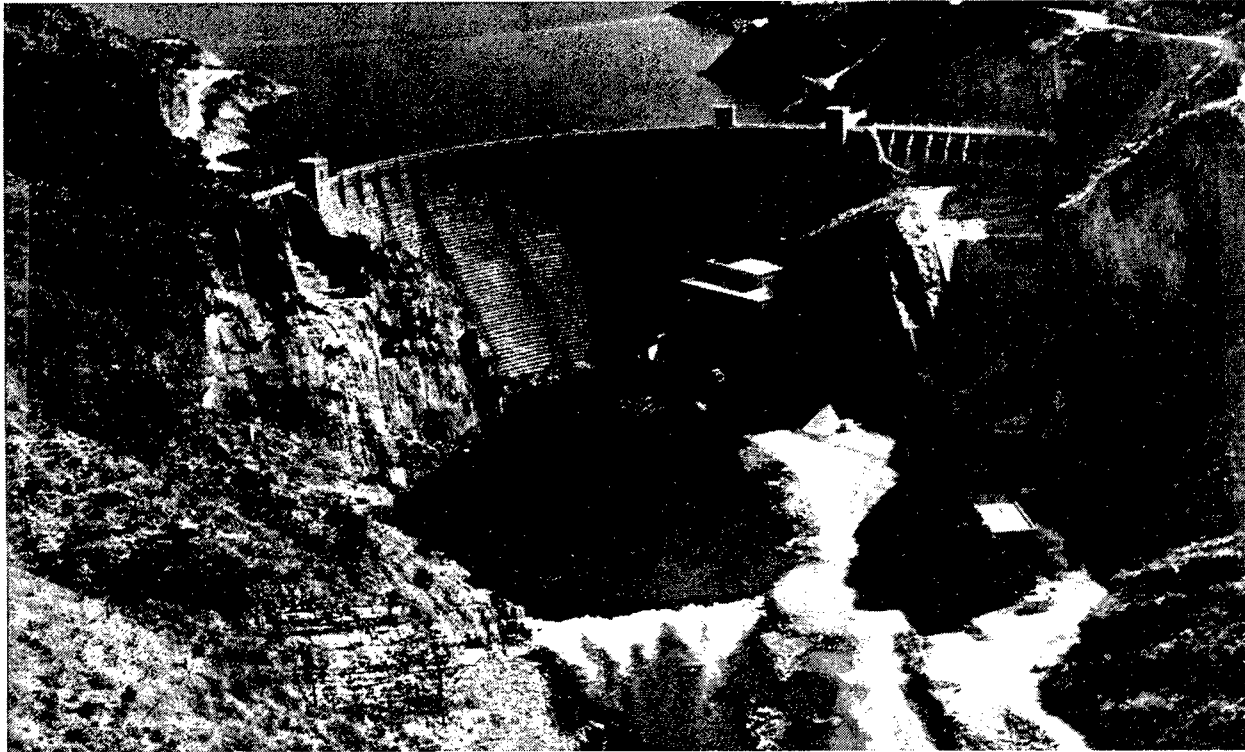

Figure 99. Theodore Roosevelt Dam prior to rehabilitation (from Quint and Fielder 1989)

In 1978, during investigations for the Federal Safety of Dams Act, Roosevelt Dam, which impounds Roosevelt Lake, was identified as a high-hazard dam in need of modifications. According to revised PMF figures (a peak inflow of 18,500 cms (654,000 cfs) and a volume of 7 billion cu m (3 million acre-ft) during a 16-day period), Roosevelt Dam would be overtopped, causing a loss of the spillways and the power plant and possibly causing failure of the three dams downstream. The loss of these dams would probably result in loss of life as well as extensive damage, including flooding in Phoenix. In addition, revised maximum credible earthquake (MCE) figures indicated Roosevelt Dam could fail in the event of an MCE. If the dam did not fail but suffered significant cracking, the low-level outlets were not adequate to empty the 1.6 billion-cu m (1.3 million-acre-ft) Roosevelt Lake in an emergency (Hepler and Drake 1995).

**Modification plan to raise and strengthen dam.** BuRec's recommendations for modifying Theodore Roosevelt Dam were approved by Congress in 1984. Work on the project began in 1989. Modifications included raising the height of the dam from 23.5 to 109 m (77 ft to 357 ft) and increasing the length to 369 m (1,210 ft). This increase in the size of the dam increased storage capacity to 1.97 billion cu m (1.6 million acre-ft). The dam's capacity to hold floodwater was increased to 2.2 billion cu m (1.8 million acre-ft). A new river outlet works was added to provide for a more efficient emptying of the reservoir

in case of an emergency. The river outlet works and the maximum spillway releases can empty 90 percent of the reservoir storage in 63 days. The modified dam can restrict releases to 4,250 cms (150,000 cfs), within the spillway capacity of the downstream dams. The dam power plant was modified to enable its operation under higher reservoir heads and tailwater.

An additional modification included in the \$347 million improvements was construction of a new steel arch bridge upstream of the dam to reroute traffic. The bridge was completed before modifications on the dam were begun. The 329-m- (1,080-ft-) long bridge is 15.2 m (50 ft) above the 200-year-flood elevation of the reservoir. It is the longest two-lane, single-span, steel-arch bridge in North America (Hepler and Drake 1995).

Basing their decision on finite element and thermal analyses, BuRec engineers decided to use a single-curvature arch design and to use mass concrete placed in 3-m- (10-ft-) high, 21.3-m- (70-ft-) wide blocks that ranged in thickness from 13 to 15.2 m (10 to 50 ft) to raise and thicken Roosevelt Dam. The blocks were placed in alternating cantilevers (Figure 100). Also, mass concrete was used for the two large thrust blocks constructed on the right and left dam abutments to transfer arch loads from the dam into the foundation.

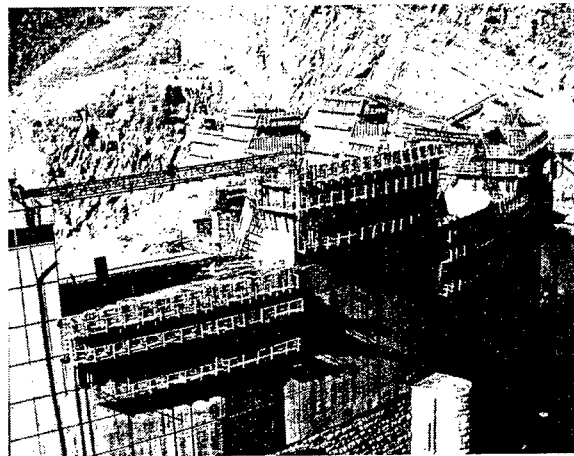

Figure 100. Alternating cantilevered placement of mass concrete blocks at Theodore Roosevelt Dam (from Balogh 1996)

**Concrete specifications.** Specifications for the concrete mixture required that it be workable, have sufficient paste to bond with the masonry, heat slowly to minimize thermal stresses, have a compressive strength of 5 MPa (750 psi) in 7 days to facilitate form removal and a compressive strength of 20.7 MPa (3,000 psi) at 1 year. Concrete was to be placed at temperatures between 4.4 and 10 °C (40 and 50 °F); joint grouting temperatures were to be between 15.5 and 18 °C (60 and 65 °F).

The final concrete mixture contained 102-mm (4-in.) maximum size aggregate, 160 kg/cu m (270 lb/cu yd) of cementitious material; the cementitious material was 80 percent Type II special low-heat cement and 20 percent flyash. The w/c was 0.53, which produced a 51-mm (2-in.) slump. The mixture had excellent workability and sufficient compressive strengths that the forms could be raised to the next lift within 4 to 7 days after concrete placement.

The batch plant was located just upstream from the dam. It supplied 107 cu m (140 cu yd) of concrete per hour. Flaked ice was used in the mixing water and chilled air was circulated through the aggregate just prior to batching to maintain correct placement temperatures. The concrete was transported to the site on a 579-m- (1,900-ft-) long cableway that delivered the concrete where it was needed.

**Construction.** Before beginning concrete placement, workers cleaned the existing masonry surface by removing all loose, chipped material and then waterblasting the surface with pressures up to 70 Mpa (10,000 psi). The concrete blocks were then constructed on the downstream face of the dam. The mass concrete for each block was consolidated in 508-mm (20-in.) layers to complete the 3-m (10-ft) lift. At the downstream face within the central arch, the nine blocks vary in width from 13.4 m (44 ft) at the base to 21 m (69 ft) at the crest. The blocks were constructed in an alternating high-low sequence (Hepler and Drake 1995). Concrete placement took place year round; during the summer when temperatures were in excess of 38 °C (100 °F), concrete was placed at night, and approximately 90 percent of the mixing water was replaced with ice, to maintain the required placement temperatures. Cooling coils were used at each lift, and cooling water was circulated over the concrete for 20 days after it was placed (Balogh 1996).

The joints were not grouted until the winter months, December to February. Grout was not pumped into contraction joints, until the circulating cooling water had lowered the concrete temperature to 15 to 18 °C (60 to 65 °F). To make sure the concrete overlay blended with the original masonry, workers attached deep wood strips to the forms at each 3 m- (10-ft) lift.

A system of horizontal, flat drains and a vertical collector pipe were installed to drain the interface of the masonry and the mass concrete. The horizontal drains, which were installed at each 3-m (10-ft) lift, were constructed of pipe wrapped in filter fabric and plastic sheeting; these pipes were attached to the existing masonry and embedded in the concrete overlay. The horizontal drains are connected to the vertical drainage system; it discharges at the toe of the dam overlay (Balogh 1996).

Quality control consisted of systematic testing of concrete materials and mixtures; testing of cylinders cast for all placements and cores, which were taken every 3 months to test compressive, tensile, and shear strengths. The concrete mixture exceeded the specifications; the average compressive strength for 7 days was 5.5 MPa (800 psi) and for 1 year, 31 MPa (4,500 psi) (Balogh 1996).

**River outlet works.** The river outlet works (ROW) tunnel was constructed from the upstream side of Roosevelt Dam around the left abutment to the downstream side of the dam. The tunnel includes an intake inlet on the upstream side, a 19.5-m (64-ft) radius curve down to the outlet, a gate shaft and steel wheel-mounted gate structure, a separate bulkhead downstream gate, a separate power penstock, and an outlet portal (Beall 1991).

To effect this construction, a lake tap was needed. Instead of a conventional uncontrolled lake tap, BuRec engineers designed a completely controlled tap for Roosevelt Dam. To construct the lake tap, workers excavated a horizontal bench (Figure 101) and a 6-m- (20-ft-) diam vertical shaft underwater. A drill mounted on a barge was used to drill the 18-m (60-ft) bench about 30 m (100 ft) underwater. A 22.6-m- (74-ft-) long template with a sonar mounted on it was used to position the drill. Information from the sonar was displayed on a cathode ray tube (CRT) with a gridded screen that showed the drill operator where to place the drill. Also, divers and a remote operated submarine with a camera monitored the work. Cuttings from the bench were sucked up an air lift, screened, and returned to the lake in a return pipe (Beall 1991).

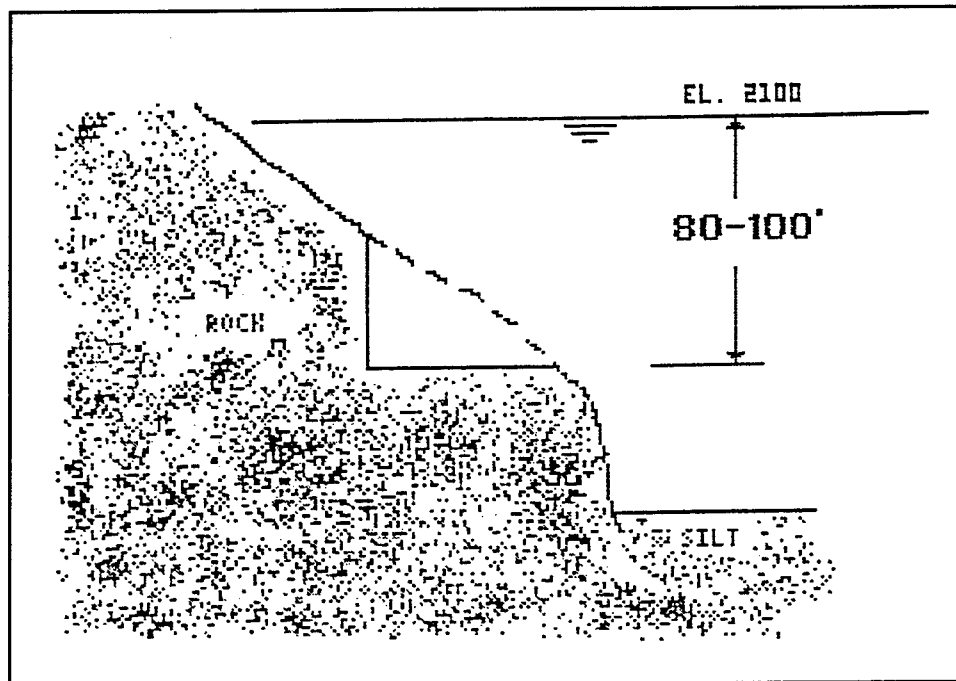

Figure 101. Bench excavation for Theodore Roosevelt Dam lake tap

Once the bench was completed, the template was cut and reformed and used for the inlet tube shaft, which was excavated in a horseshoe shape to accommodate the 1.6-radian (90-deg) angle in the inlet tube (Figure 102). The steel inlet tube was floated out to the site and inserted in the completed shaft. The inlet tube was grouted into place with tremie concrete (Figure 103). Specifications for the tremie concrete called for a 27.6 MPa (4,000-psi) compressive strength. The mixture contained 25-mm (1-in.) aggregate and a plasticizer. The ROW tunnel is 200.6 m (658 ft) long with a 4.9-m (16-ft) finished diam. Reinforced concrete was used to line the section of the ROW upstream of the gate chamber, and the cross section downstream of the bifurcation structure is lined with steel and reinforced concrete. After the inlet tube was installed, capped with a bulkhead, and dewatered, the remainder of the ROW was mined along the pilot tunnel to the inlet and from the gate shaft to the outlet. Then the 108.2-m- (355-ft-) long, 3.8-m- (12.5-ft-) diam power penstock tunnel was constructed, the



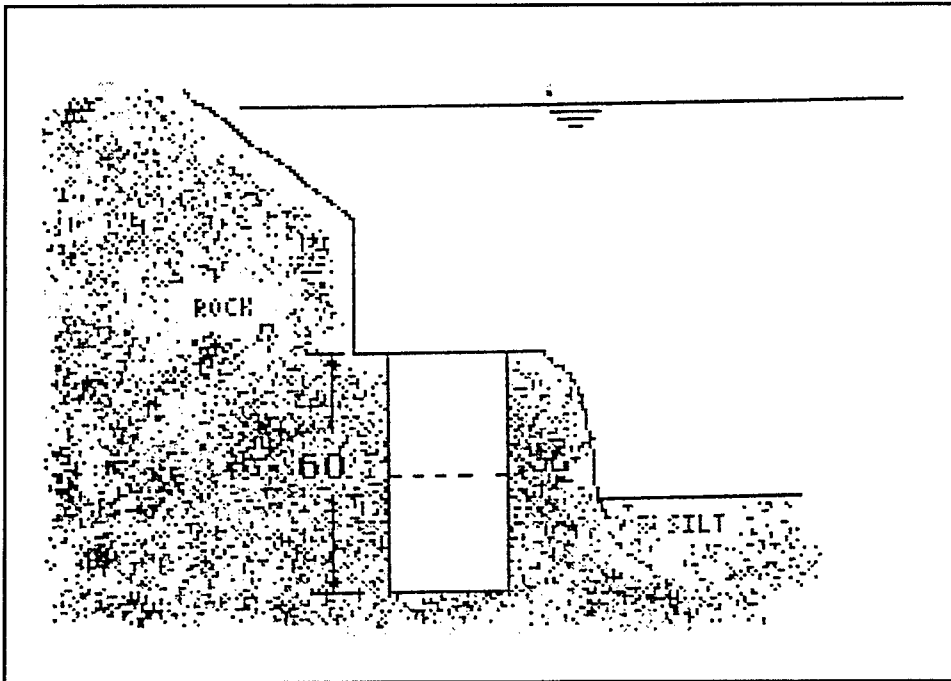

Figure 102. Inlet tube shaft at Theodore Roosevelt Dam

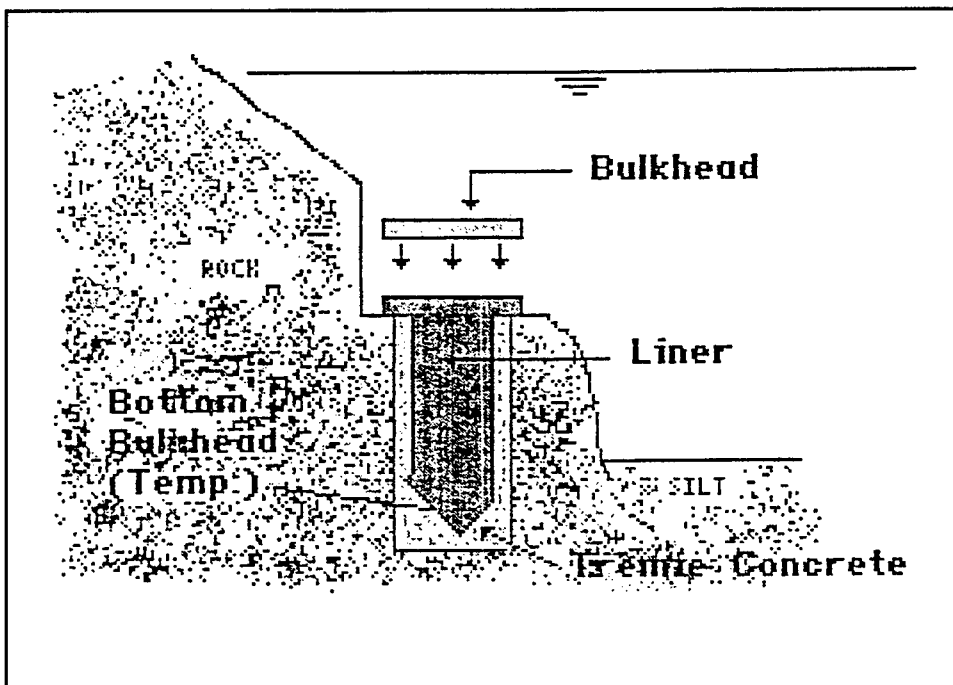

Figure 103. Inlet tub placement with tremie concrete at Theodore Roosevelt Dam

gate was installed in the gate shaft, and alterations were made to the power plant (Figure 104). The original 49,500-horse-power (hp) turbine was replaced with a new, smaller turbine having the same capacity and capable of operating at the new higher reservoir heads (Beall 1991).

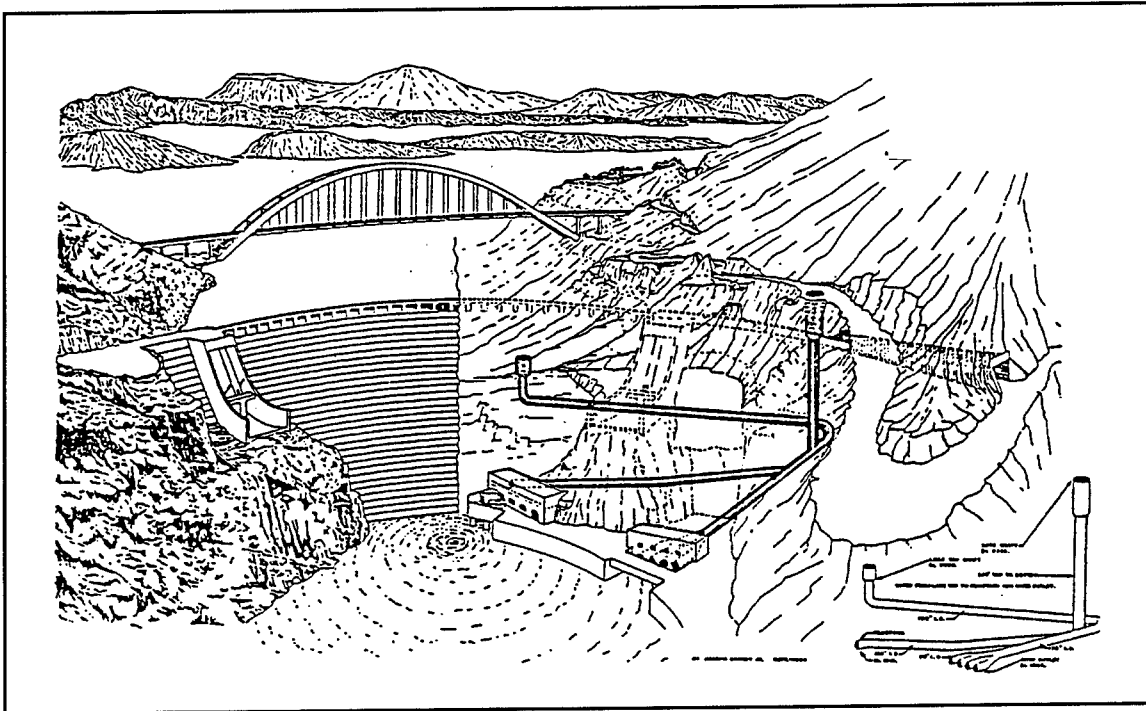

Figure 104. Penstock tunnel installed at Theodore Roosevelt Dam

Environmental impacts were considered in the design and construction of the alterations. In order to preserve the valuable reservoir water for use in the arid Phoenix region, the total drawdown during rehabilitation was limited to 6 m (20 ft). During construction, one spillway was kept available at all times in case of flooding, and a 3.3-m- (129-in.-) diam pipe was used to divert streamflow. The pipe extended 161.5 m (530 ft) downstream from the ROW to a downstream cofferdam. The diversion pipe had a capacity of 142 cms (5,000 cfs), which when combined with reservoir storage capacity would have permitted control of a 20-year flood without spillway releases (Hepler and Drake 1995).

During January 1993, record rainfall interrupted the work. The eight available spillways were forced into use, and the tailrace area had to be evacuated. On January 19, the reservoir rose to el 2,139 ft, the highest level in the dam's history. Flooding lasted for 3 weeks, and spillway releases continued until March 8. The construction contract had to be extended to May 1996 from July 1995 (Hepler and Drake 1995).

Once the concrete overlay was installed, exposed concrete surfaces were cleaned and stained so they would more closely match the surrounding rock. Figure 105 provides an overall view of the modifications to the structure.



Figure 105. Modifications performed at Theodore Roosevelt Dam

The U.S. Forest Service will spend about \$39 million in BuRec funds to design and construct recreation facilities on Roosevelt Lake. Plans include developing individual campsites, picnic sites, boat launch areas, and fish cleaning stations. A new visitors' center and a sheriff's aid station have already opened (Hepler and Drake 1995).

### **Upper Stillwater Dam**

Upper Stillwater Dam is located 72 km (45 miles) north of Duchesne, Utah. The dam, which was completed in August 1987, was constructed with roller compacted concrete (RCC), placed without contraction joints. Engineers expected cracks to develop in the RCC as a result of the placement method.

During the first filling of the reservoir in June 1988, a crack was discovered in the foundation gallery. As the reservoir continued to fill, the crack widened and eventually extended from the foundation gallery at station 25 + 20 to the crest and on both the upstream and downstream faces of the dam near station 25 + 15. At full reservoir head, the crack was 6.6 mm (0.26 in.) wide and allowed about 4,920  $\ell$ /min (1,300 gal/min) to leak into the gallery and about 6,810  $\ell$ /min (1,800 gal/min) to leak from the crack on the downstream face (Figure 106). This amount of leakage was considered unacceptable. When the reservoir was drawn down, the crack width decreased to about 3 mm (0.1 in.) and the leakage slowed. This change in crack width indicated foundation deformation and concrete cooling enhanced the formation of the cracks in the dam.

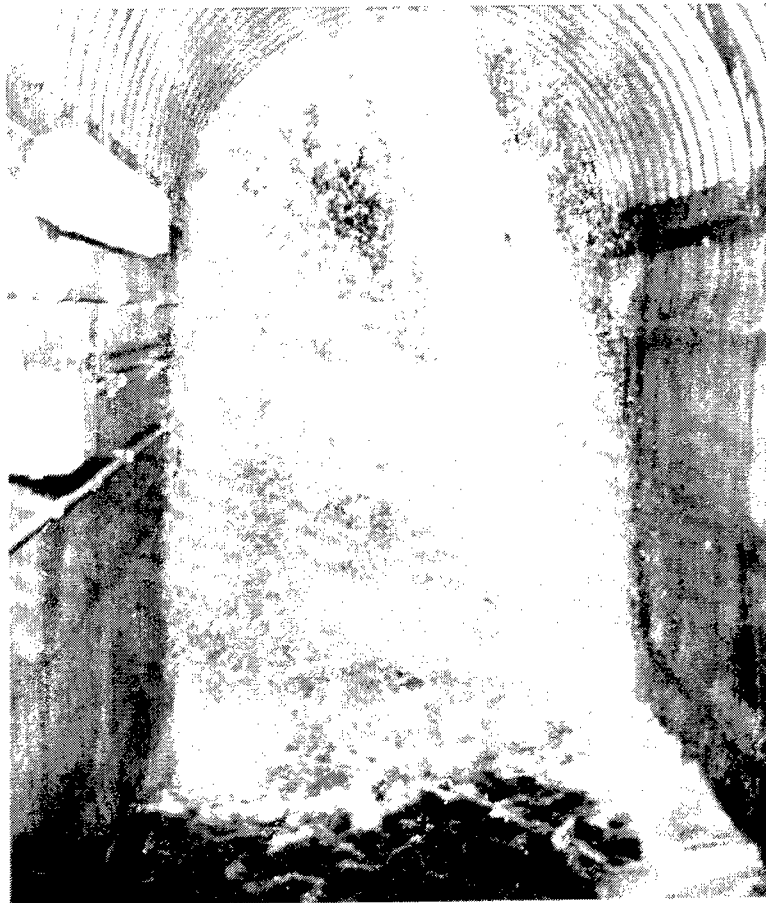

Figure 106. Leakage into the foundation gallery at Upper Stillwater Dam (from Smoak 1991)

The Bureau of Reclamation decided to repair this and several smaller cracks by pressure injecting them with resin. This case study is a summary of the repair procedure reported by Smoak (1991).

Because the reservoir level would change with the seasons, creating the potential for crack movement, a flexible hydrophilic polyurethane resin was selected as the repair material. Another characteristic of this material is that it allows for multiple injections. The injection was accomplished in three stages. Work for the first two stages was executed from the gallery and the downstream face at elevations below the reservoir water level. The first objective of the first stage was to cut off the flow of water into the gallery. A series of 16-mm (5/8-in.) holes were drilled from the gallery walls at an angle to intercept the crack at depths of 0.3 to 0.9 m (1 to 3 ft.) Injector valves ("wall spears") were placed in the holes and opened to relieve the water pressure in the crack. The surface of the crack between wall spears was then sealed with wood wedges, lead wool, or urethane-soaked jute rope or oakum. When the flow of water was controlled, a urethane resin pump system was connected to the injectors, and resin was pressure injected into the crack (Figure 107). If needed, the crack was reinjected.

The major work in the repair project was performed during the second stage. The first step was to drill 25-mm-(2-in.-) diam holes to intercept the crack at the locations shown in Figure 108. The holes varied in depth from 5.8 to 28 m (19 to 92 ft). When the drill hole intercepted the crack, as evidenced by the drill water loss, a pneumatic packer was set several feet from the hole-crack intercept, and the hole was injected with resin. The D-line of holes was drilled and injected first to reduce water flow during drilling and injection of interior holes. The alphabetical designation of the holes

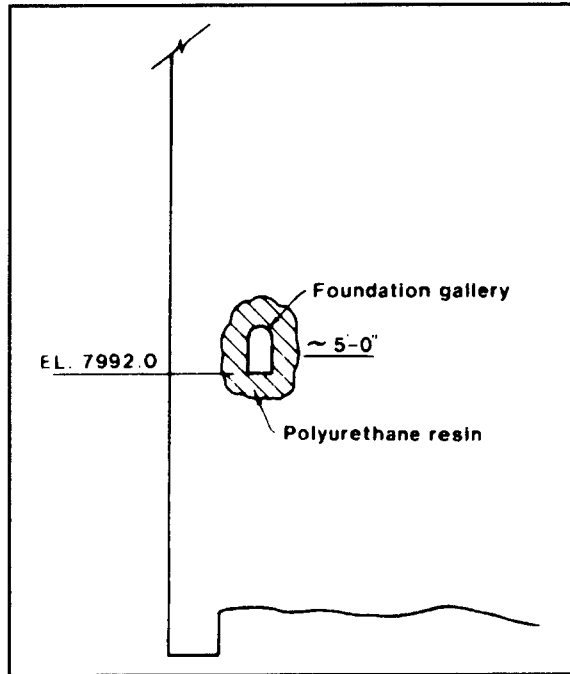

Figure 107. Plan for first injection stage at Upper Stillwater Dam (from Smoak 1991)

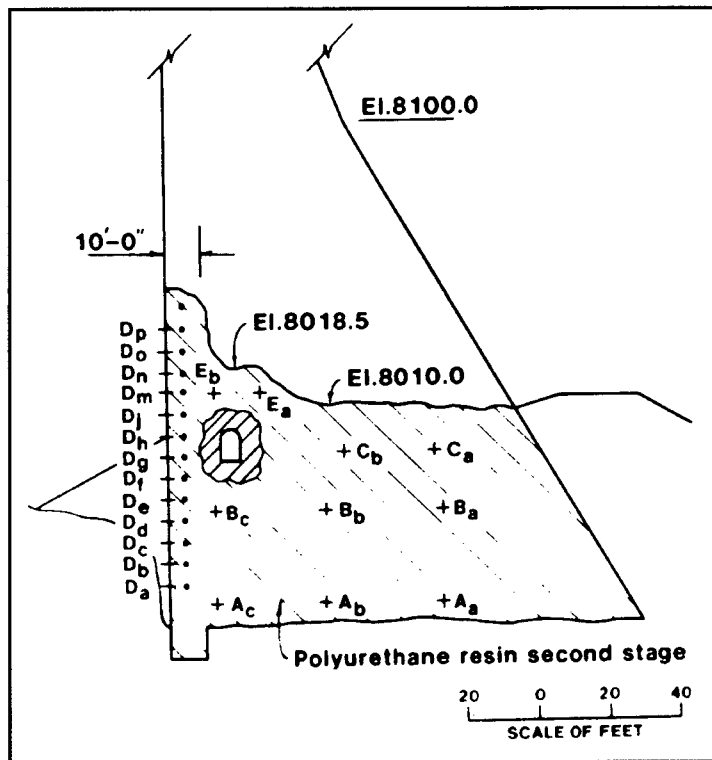

Figure 108. Injection plan for Stage 2 of Upper Stillwater Dam (from Smoak 1991)

indicates the sequence of drilling and injection. Water-to-resin ratios varied from 0:1 (neat resin) to 2:1 with most injections done at a 1:1 ratio. Check holes were used to determine whether the crack had been sealed; if not, additional holes were drilled and injected until the crack was adequately sealed.

The third stage of the injection involved sealing the crack on the upstream face of the dam above the drawn-down water level. A floating barge and a spider platform suspended from the top of the dam were used as work platforms during the drilling and injection procedures (Figure 109). Crack intercept holes were drilled 305 to 610 mm (12 to 24 in.) apart on alternate sides of the crack and angled so they would intercept the crack about 0.6 m (2 ft) from the upstream face. Wall spears were installed and then the holes were pressure injected with resin. Workers started at the lowest injection hole and moved up the crack to the top of the dam. Resin volumes were calculated to permit injection of a zone approximately 3 m (10 ft) into the dam; however, in some instances, miscalculations resulted in the resin penetrating the entire section and coming out on the downstream face. A 1:1 water-to-resin ratio was used for the crack at these elevations. Check holes were used to determine whether the crack was sealed.

A similar procedure was used to seal the smaller cracks in the dam. After the repair of the cracks, and at full reservoir, no measurable leakage was detected at any of the smaller cracks. The leakage at the largest crack was reduced from 11,700  $\ell$ pm (3,100 gpm) to less than 3,030  $\ell$ pm (800 gpm).

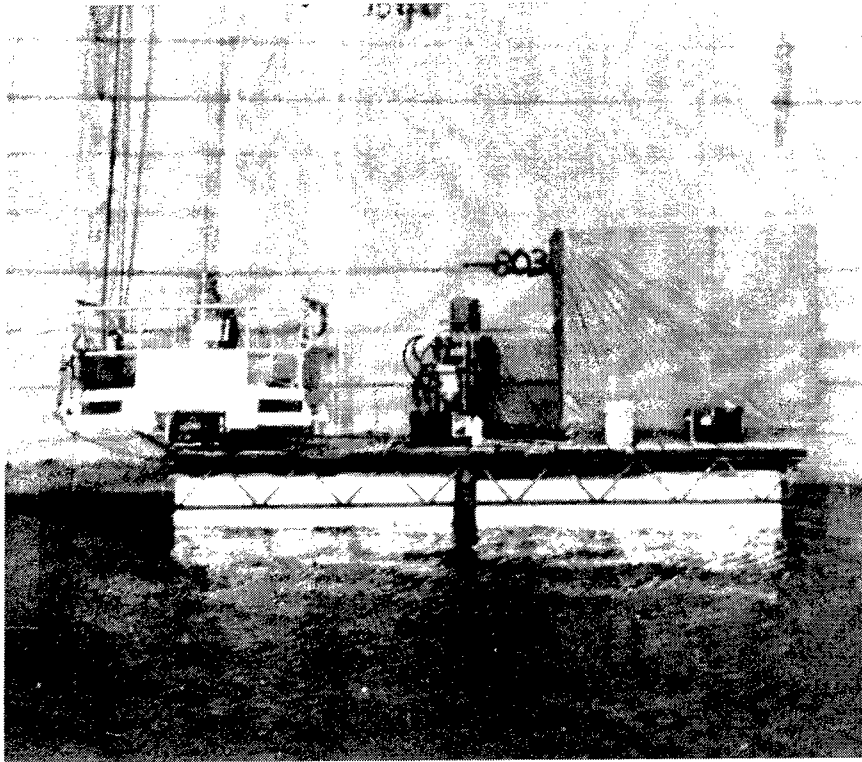

Figure 109. Work platform used at Upper Stillwater Dam (from Smoak 1991)

## Ute Dam

Ute Dam, is situated on the Canadian River in east-central New Mexico near Logan, NM. Owned and operated by New Mexico Interstate Stream Commission (NMISC), the dam was completed in 1963. The original structure consisted of a 36.6-m- (120-ft) high zoned embankment main dam, an ungated ogee-type concrete spillway with a 256-m (840-ft) crest located to the left of the main dam; and a 7.3-m (24-ft) maximum height embankment dike located to the left of the spillway.

The dam did not provide sufficient storage capacity to permit use of its full storage allotment, as agreed in the Canadian River Compact. NMISC requested the Bureau of Reclamation to modify the dam so that it would provide the desired reservoir capacity. BuRec prepared appraisal designs and estimates for several types of gated structures; the minimum field cost for a structure of this type was approximately \$34 million (based on 1980 prices). Since this cost was unacceptable to NMISC, the Bureau prepared several ungated alternative designs. The most economical alternative, which was approved by NMISC, was to construct a labyrinth spillway and raise the dam; the estimated cost for this modification was \$10 million.

The advantage of the labyrinth spillway is that its zigzag configuration increases the effectiveness of a spillway within the existing length of the dam. Ute Dam was well suited for a labyrinth spillway in that the dam's approach flow is parallel to the spillway center line; this configuration is required for greatest efficiency of a labyrinth spillway. This cantilever-type free overflow structure can provide reservoir storage capacity of a standard spillway economically without the necessity of manual or mechanical operation. Hinchliff and Houston (1984) described the modification Of Ute Dam. This case history is a summary of their report.

A hydraulic model was used for the design of the spillway. A 14-cycle spillway passed the required maximum discharge at 5.8 m (19 ft) of head. In addition to the labyrinth spillway shape, the model was used to determine the effect of nappe interference, impact pressures in the downstream channel, water surface profiles in the upstream channel, and low flow conditions.

Once the hydraulic design was completed, the labyrinth spillway was analyzed for stability and structural integrity. Analyses showed that a typical full cycle was stable against overturning, but required a 1.5-m- (5-ft-) deep key trench to provide an adequate factor of safety against sliding. The foundation bearing pressure was acceptable for the loading conditions. To make the end-half cycle of the labyrinth stable against overturning, an anchor block was attached to the existing spillway end wall. The anchor block and key trench allowed the existing end wall and the labyrinth half cycle to act as a unit.

Construction on the labyrinth spillway at Ute Dam began in November 1982. The original sandstone spillway area was excavated with a Roto-Mill profiler for the labyrinth spillway foundation. Areas of clay seams and fractured sandstone were overexcavated and backfilled with concrete. The 1.5-m- (5-ft-) wide key

trench for the labyrinth base slab was excavated with a trenching machine and a backhoe.

After excavation was completed, a series of 102-mm- (4-in.-) diam split drain pipes were installed on the foundation surface to intercept seepage and reduce uplift pressures on the base of the labyrinth. Water collected by the split drains is carried downstream of the labyrinth and passed through the existing ogee in a series of holes drilled horizontally through the crest. A line of 21-m- (70-ft-) deep relief wells was drilled immediately upstream of the crest to prevent excessive uplift pressure from developing beneath the existing structure. These wells were cased with slotted pipe and capped with a flat valve to prevent debris from plugging the hole.

Forms for the base slab were then constructed and reinforcement installed. Because the labyrinth is a cantilever-type structure, most of the reinforcement for the wall had to be embedded in the base slab before the concrete for the base was placed. This procedure created difficulties in placing the large amounts of reinforcement required and in supporting the steel for the walls of the labyrinth. Forming the control joints within the base slab was also difficult because of the number of reinforcing bars that had to pass through the joint and the installation of PVC waterstops along the joint.

Construction started with the center cycle of the labyrinth and proceeded toward the ends. Concrete with a design strength of 34.5 MPa (5,000 psi) at 90 days was placed for the base slab at each cycle in seven different sections, each delineated by control joints. Concrete for the walls was placed in 3-m- (10-ft-) high lifts, also delineated by control joints. No concrete was placed in immediate sections of the base or wall until the abutting concrete had been in place for at least 7 days. This was done to ensure the concrete had contracted to its final dimensions and provided tight joints.

Discharge flowing over the labyrinth spillway increases in direct proportion to crest length; however, hydraulic model tests show that when hydraulic head increases, discharge efficiency decreases. Piers were placed along the spillway crest at Ute Dam to split the flow and allow air to enter under the flow nappe; the split flow reduces oscillation in atmospheric pressure and noise produced when the spillway is operated under low hydraulic head (Parrett 1986). The completed labyrinth spillway is shown in Figure 110.

## **Tennessee Valley Authority**

### **Chickamauga Lock and Dam**

Chickamauga Lock and Dam was completed in January 1936. Shortly after construction was completed, pattern cracking was noted on the concrete surfaces of the dam; however, to this date no repairs to the surface have been required.



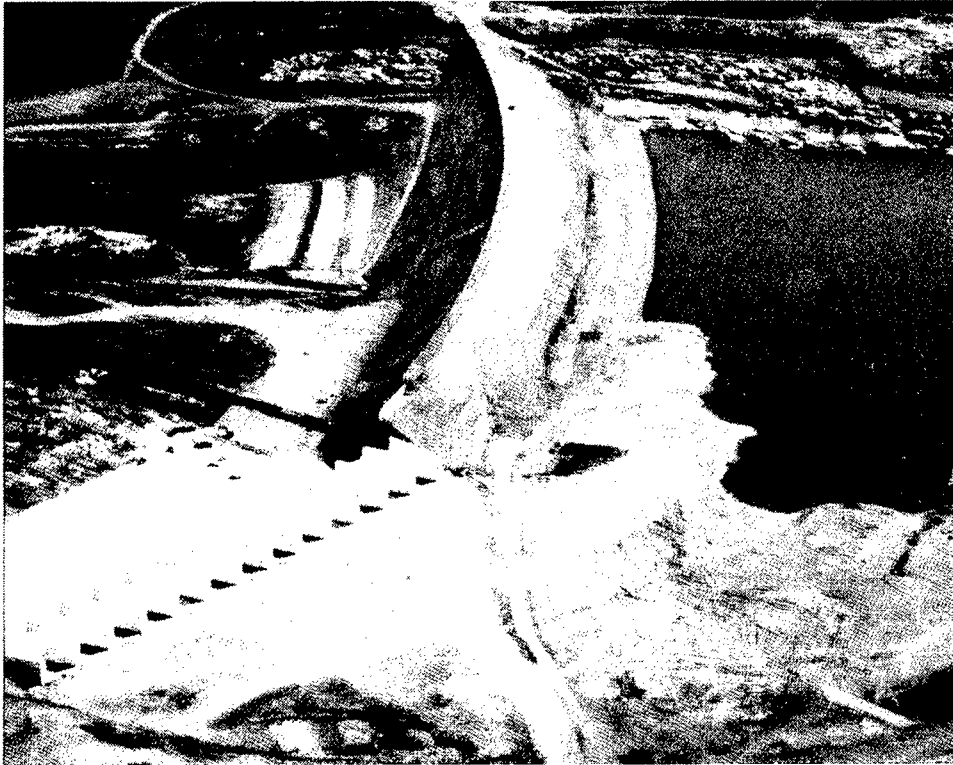

Figure 110. Ute Dam with completed labyrinth spillway (from Parrett 1986)

Later, structural problems developed as evidenced by misalignment in the powerhouse; the misalignment was attributed mainly to alkali-aggregate reactivity and its resulting expansion of the concrete. All the generating equipment and heavy crane runners have required realignment, but the most dramatic evidence of concrete growth has been in the navigation lock.

In 1964, a joint opening and vertical offset was discovered at the upstream joint of the upper approach wall of the lock. Divers inspected the six piers that support the wall and found cracks on the two upstream piers, which indicated the wall was expanding and moving the pier tops upstream. All contraction joints in the wall were very tight, and portions of the wall appeared to have increased in height. To alleviate the adverse effect of the expanding (growing) wall and allow room for future expansion, three slots were cut in the wall in 1965. In addition, the two upstream piers which had cracked were posttensioned.

In 1977 divers discovered similar cracking in the other four piers. During the same inspection, a large crack near the end of the lower river approach wall was discovered. This crack was grouted and posttensioned later that year. The wall is supported by four 5.3 m- (17.5-) ft-diam sheet-pile cells that are filled with tremie concrete. A separation between a downstream portion of the cells and the bottom face of the wall was found on the three downstream cells. Subsequently, a slot was cut across the wall, upstream of the four cells, to provide space for future concrete growth.

Also in 1977, diagonal cracks were discovered in the piers between the discharge ports of both the land and river walls. Cracking in the land wall was very minor.

In 1979 and 1980, the three existing slots on the upper approach wall were recut, one additional slot was drilled, and the four piers were posttensioned. These slots are gradually closing. Also, in 1980, the cracks in the lower river wall discharge piers appeared to have worsened. Solid 127 mm- (5-in.-) diam steel bars were installed in vertically drilled holes in the piers to ensure adequate load-carrying ability.

In 1983, a vertical crack and three horizontal cracks were discovered in the lower river wall gate block, and a horizontal crack was found in the adjoining downstream block. Repairs to the vertical crack completed in 1984 consisted of grouting the crack with a neat cement grout and posttensioning with high-strength reinforcing bars. The horizontal cracks in the gate block and adjoining downstream block were grouted and posttensioned with multistrand tendons.

With the exception of the surface cracking, the overall condition of the concrete is good. Compressive strength tests of core samples range from 27.6 to 55 MPa (4,000 to 8,000 psi) (Hammer and Buttrey 1984).

## **Fontana Dam**

Fontana Dam is located in a deep steep-sided gorge in the counties of Swain and Graham in western North Carolina. The Tennessee Valley Authority (TVA) completed the 146-m- (480-ft-) high, 721-m- (2,365-ft-) long concrete gravity structure in 1945. The project consists of a concrete nonoverflow dam, a service spillway with four radial gated bays, an emergency overflow spillway, and a 3-unit powerhouse.

Two monoliths between the main body of the dam and the spillway curved in plan, resulting in the axis of the dam turning through an angle of about 0.6 radian (35.5 deg). For approximately 30 years the dam was operated and monitored with no significant problems. Late in 1972, however, during a routine structural inspection, cracking was observed in the walls of the foundation drainage gallery in the curved portion of the dam near the left abutment. Further field investigations revealed the cracking to be excessive, so a comprehensive program of analysis and repair was initiated.

The 6.4-mm (1/4-in.) maximum width crack extended into the adjacent straight block on each side of the blocks comprising the curved portion of the dam and had a 4.8-mm (3/16-in.) maximum upstream offset of the wall face above the crack relative to the face below the crack. The observable cracking indicated an inclined plane intersected the gallery and sloped upward towards the downstream face. The cracking extended from the gallery to the downstream face as well as a short distance upstream of the gallery. Gauges were installed

across the crack and observations early in the 1973 warm season indicated the crack to the opening.

The downstream face of the dam receives the full force of the afternoon sun. The high temperatures were considered a contributing factor to the cracking, as was indicated by the increasing rate of crack opening during warmer seasons. Temperature data indicated a seasonal temperature fluctuation affecting the exterior 11 m (36 ft) of the mass. Comparison of temperatures measured in 1961 and 1971 indicated a slight average temperature rise may have occurred in the upper portion of the dam during this period. Also, petrographic examinations disclosed small deposits of alkali-silica gel, very fine cracks in a few aggregate particles, and a deficiency in calcium hydroxide in the cement paste.

The conclusion reached was that a slow alkali-silica reaction plus an increase in temperature over a portion of the dam was producing an increase in volume. This increase was effectively resisted longitudinally by the foundation, except near the curve of the dam. In that portion of the dam, the longitudinal thrust created a force tending to overturn the curved blocks, resulting in tension in the downstream face which led to the cracking.

When the crack was discovered, TVA took action immediately to ensure the integrity of the dam. One of the first measures taken was to "stitch up" or posttension the crack (Figure 111). The work was performed from a barge on the lake face of the dam. Holes were percussion drilled into the dam on a diagonal that crossed the crack and went far enough past it to provide grouted anchorage for the tendons. Hole depths for adjacent tendons were varied to prevent a concentration of anchorage zone loads. The posttensioning cables were inserted in the holes. A total of 25 tendons were used in the three most affected blocks, which included the two curved blocks. Each tendon consisted of 90 wires, each 6.4 mm (1/4-in.) in diam. Initially the tendons were posttensioned to 20 percent of their ultimate strength. The grouting served the dual purpose of restoring shear resistance along the plane of the crack and preventing possible movement of the blocks during cable tensioning. The stitching was completed in September 1973 and will be a part of the permanent repair. However, while the posttensioning was in progress, TVA engineers learned through instrumentation that the crack might still be growing. As an interim measure, they installed a pipe system to spray cold reservoir water onto the downstream face. The beneficial efforts of this spraying were quickly apparent, as the rate of crack opening diminished significantly within a few days after the spraying began.

Since strengthening of the cracked blocks and spraying the dam during warm weather were not considered adequate as a permanent solution, TVA engineers decided to interrupt the longitudinal thrust by cutting a wide expansion slot across the upper portion of the dam. A series of investigations and laboratory analyses on core samples led engineers to the conclusion that cutting the slot in the curved portion of the dam would have no adverse effect on the stability or load-carrying capacity of the rest of the dam, and it was determined that optimum stress relief would result from locating a single 30.5 m (100-ft) deep slot at the contraction joint between the last monolith of the straight main body

of the dam and the first curved block. In 1976, this slot was cut transverse to the dam adjacent to the curve at this location.

To cut the expansion slot, workers percussion drilled a series of overlapping 127-mm- (5-in.-) diam holes located 114 mm (4-1/2 in.) on center. The holes were drilled vertically into the top and downstream face of the dam. To overcome the difficult problem of maintaining proper alignment, workers first drilled an accurately controlled pilot hole at the beginning of each series of percussion holes.

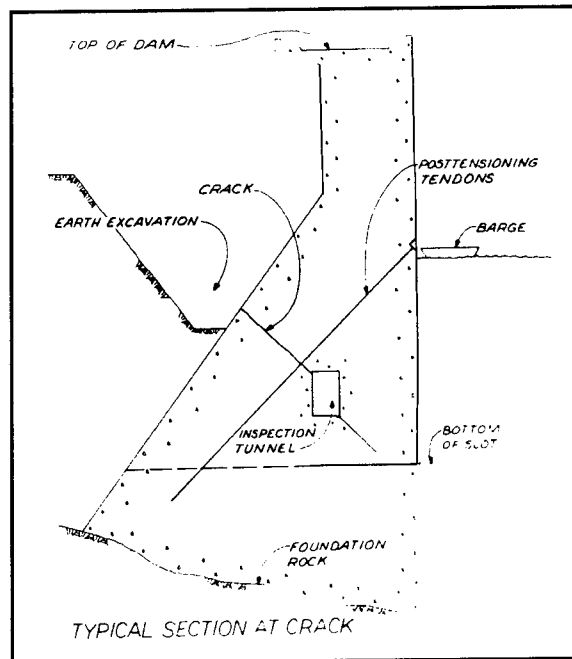

Figure 111. Crack repair with posttensioning tendons at Fontana Dam (from *TVA Today* 1976)

A system of flexible primary and secondary seals was installed at the slot to prevent leakage during high reservoirs. The primary seal was installed at the upstream face, and the secondary seal was placed in a 0.9-m (3 ft-) diam calyx hole. This hole, centered 1.2 m (4 ft) downstream of the face, was drilled to a level a few feet below the bottom of the slot. Both seals consisted of 14.3-mm- (9/16-in.-) thick industrial rubber conveyor belt stock 0.8 m (30 in.) wide. The primary seal on the upstream face was extended to the foundation (Abraham and Sloan 1978).

A considerable program of monitoring has been maintained prior to and since completion of the slot cutting. In addition to monitoring movement of the crack and slot closure, instrumentation at Fontana Dam provides measurements of temperatures, strains, joint openings, uplift, deflection (by use of long plumb lines), gallery drainage, alignment along the axis, growth, and stress under the slot. Data observations indicate the dam is still "growing."

Alignment and plumb line readings show the top of the dam has experienced a long-term upstream movement of approximately 76 mm (3 in.). By the summer of 1983, the upmost portion of the slot had completely closed and was recut to a depth of approximately 15 m (50 ft) in late 1983. Total permanent closure of the slot has been almost 76 mm (3 in.) since the slot was initially cut in 1976. Frequent observations are continuing on both the original dam monitoring instruments and on new instruments installed at the crack and at the slot. Stresses beneath the slot, measured both by strain meters installed beneath the slot and by in situ testing using overcoring techniques, have increased approximately 13.8 MPa (2,000 psi) since cutting the slot.

Other growth problems have appeared in the separate emergency spillway structure at the project. Total upstream movement of the top of this arch spillway had reached 279 mm (11 in.) by 1984. Concrete growth has also caused binding of the main spillway gates, requiring periodic trimming of the overflow skirts to obtain adequate clearance to fully open the gates (Hammer and Buttrey 1984).

In 1983, a bore-hole camera was used to inspect bore holes made during a drilling program begun in the summer of 1982. The inspection revealed that all joints appear to be bonded with the exception of the upper portion. Also, test results indicate high tensile stresses in the areas of the grouted joints. Because the conclusion was that the grouted joints could not handle these stresses, meaning the block would not act monolithically, a Phase II analysis was made with a two-dimensional (2-D) nonlinear finite element analysis. This analysis indicated that while cracking along the joints would occur, the dam will not overturn during an MVE and that an acceptable factor of safety against sliding still exists (Sharma and Sarkaria 1985).

## Other Structures

### Bhakra Dam

Bhakra Dam is located on the Sutlej River near Himachel Pradesh, India. The 225-m- (740-ft-) high concrete dam, which was completed in 1963, impounds a reservoir that supplies energy to two power plants, one on either side of the dam's 152-m- (500-ft-) high spillway. The spillway discharges floodwater at a rate of 6,776 cms (239,330 cfs) into a 128-m- (420-ft-) long stilling basin. The stilling basin is divided into two equal compartments by a wall.

When divers inspected the stilling basin, they found erosion damage, which was attributed to gravel and boulders that passed through the stilling basin during flood discharge. The damage varied in depth from 50 to 700 mm (2 to 27.5 in.). Because the two power plants had to remain in operation, the damage was initially repaired with conventional underwater concrete methods. A subsequent inspection revealed that the repair had failed because of inadequate bonding of the new and old concrete. Therefore, a new method of repair that would allow for the necessary bonding while keeping the power plants operating was needed. Malholtra, Agarwal, and Bhat (1987) described the new repair method. This case history is a summary of their report.

The solution was to construct a 26-m (85-ft-) high steel caisson that could be used to dewater the repair area and then use conventional concrete repair methods in the near-dry area. The square double-walled caisson consisted of 12 upper units and a bottom unit containing two sections. A toe plate on the bottom section maintained the vertical position of the caisson when repairs were made to sloping surfaces. The 4- by 4-m (13.1- by 13.1-ft) center hole had a

double hatch cover for an air lock and was used to regulate the passing of men and materials. The bottom section area was increased to provide a 9.5- by 9.5-m (31-by 31-ft) working area. The air lock consisted of a compression and decompression chamber. The primary air compressor supplied air at a rate of 78 cu m/min (2,750 cu ft/min) and was capable of running continuously for 10 to 15 days. A standby air compressor had a capacity of 21 cu m/min (740 cu ft/min) (Figure 112).

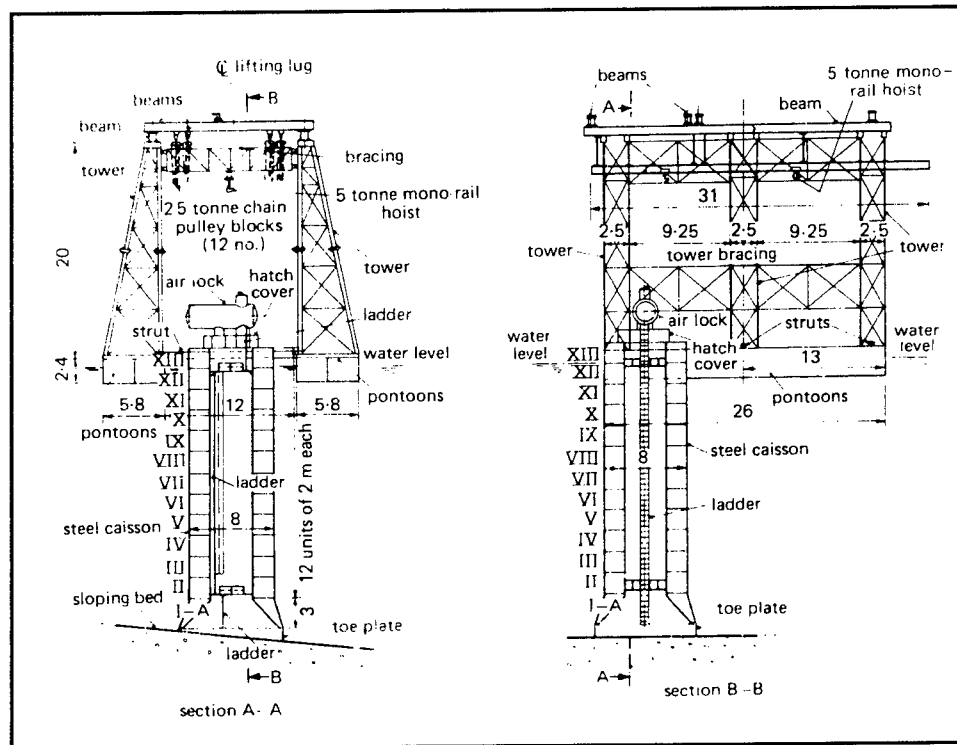

Figure 112. Design of pneumatic caisson and the sinking set used at Bhakra Dam (from Malholtra et al. 1987)

Once the caisson was constructed, ballast was added to provide a net downward load of 40 to 50 Mg (44 to 55 tons). Air pressure was applied so the caisson would float, and then pontoon-mounted winches were used to position it. As air pressure was released from the caisson, it was lowered with chain pulley blocks to ground it. Then water was pumped into the wall cavity with the required ballast. When the desired load had been created, the caisson was pressurized to remove the water, and then the tow plate was sealed.

Concrete repair consisted of cleaning the concrete surface with an air/water jet, removing deteriorated concrete manually or pneumatically, and repairing the eroded concrete. The repair method depended upon the depth of erosion. Deterioration less than 50 mm (2 in.) was replaced with epoxy concrete to designated height. Areas of deterioration in excess of 50 mm (2 in.) were coated with epoxy before the new concrete was placed. If the depth of erosion exceeded 200 mm (8 in.), epoxy-grouted dowels were installed on 0.6-m (2-ft) centers to anchor the new concrete, and joints were treated with epoxy paint.

From 92 to 154 hours was required to repair one setting, an area of approximately 60 sq m (650 sq ft). Work was interrupted by the monsoon season. The equipment had to be dismantled and then reerected when flooding was over and work could be reassumed.

Because working inside a pneumatic caisson can be dangerous, project engineers took special precautions: only experienced personnel were employed, a qualified doctor remained on site during the work and all persons entering the caisson were medically supervised, working hours were strictly controlled, hot drinks were supplied, the temperature was carefully monitored, oil-free compressed air was used, the compression and decompression chambers were sufficiently large, pressure gauges were tested on a regular basis, and emergency lighting inside the caisson was available.

### **Big Eddy Dam**

Big Eddy Dam is a concrete buttress gravity structure located 45 m (28 miles) southwest of Sudbury, Ontario, Canada, on the Spanish River. It was constructed between 1918 and 1922. The 44-m- (145-ft-) high, 351-m- (1,150-ft-) long dam, which impounds Lake Agnew, is used to provide hydroelectric power (Figure 113).



Figure 113. Big Eddy Dam (from Gore and Bickley 1987)

Since its construction, Big Eddy Dam has suffered severe visible deterioration of the concrete and has experienced extensive seepage of water throughout the dam. A variety of repair methods was tried; all failed to halt the concrete deterioration and the seepage. The failure of a shotcrete repair of the downstream face is shown in Figure 114.

In 1974, International Nickel Company, owner of the dam, initiated an investigation to determine the cause of the major problems at the dam. A visual inspection and testing of cores taken from the east wing wall were accomplished. The main causes of deterioration were identified as cycles of freezing and thawing and alkali-aggregate reaction. Further investigation in 1975 indicated a need for a comprehensive study of the dam. Gore and Bickley (1987) reported the investigation and subsequent remedial steps taken. This case history is a summary of their report.



Figure 114. Deteriorated shotcrete repair on the downstream face of Big Eddy Dam (from Gore and Bickley 1987)

In 1978, investigators were hired to determine the integrity and safety of the dam; estimate the rate of continued deterioration; determine the costs, methods, and specifications for remedial work that would allow the structure to be operational for 50 additional years; recommend the scope and phasing of remedial measures; and calculate the structural factor of safety prior to repair and in a presumed restored condition. The following conclusions were drawn from this study, which included a visual survey, examination of foundation material, and a coring program: no problems with the foundation bedrock were anticipated within the next 50 years; the slag aggregate concrete in the core of the dam was sound, dense, and had an average compressive strength of 39 Mpa (5,200 psi) and was expected not to deteriorate significantly over the next 50 years; both the upstream face (above the low water level) and downstream face of the dam had suffered significant damage as a result of exposure to cycles of freezing and thawing; deterioration of the repair concrete was expected to continue until the repair concrete cladding was completely lost, a result of the incompatibility of the repair concrete and the slag concrete core and the reactive and deleterious aggregate used in the repair concrete; the deterioration and leaching of horizontal construction joints was expected to continue because of open discontinuities within the dam that allowed water to seep through the structure; the dam appeared to be stable against sliding, but the calculated toppling stability



was considered marginal, especially as leaching of the horizontal joints was expected to continue.

Recommended remedial measures in priority order included improvement of the overall stability of the dam, elimination of leakage through the structure, and replacement of deteriorated surface concrete.

To improve dam stability, posttensioned anchors were installed through the dam into the bedrock. This process began with drilling 32 vertical anchor holes; core holes previously used for inspection were deepened and used as anchor holes when possible. Falling headwater tests were used to determine the grout tightness of the drill holes; if necessary, the holes were grouted and then redrilled. These precautions were taken to prevent localized leakage from creating voids that would eventually result in loss of anchor strength and increased corrosion.

After the anchor recesses were cut, the anchor cables were placed in the holes. Each cable consisted of 12 strands of 1.6-mm- (0.62-in.-) diam, extra-high-strength stabilized steel. The portion of the cables that passed through the concrete of the dam were sheathed in plastic and a corrosion-resistant grease packing was placed between the sheath and the individual steel strands. The 8.2-m (27-ft) cable sections that extended into the foundation were not sheathed, but were exposed and grouted into place.

Six batches of cement mortar were used to grout the 32 cable anchors. The mixture proportion consisted of 40 kg (88 lb) of Type III high-early-strength portland cement, 0.34 kg (3/4 lb) of Porzite 70 with aluminum powder in the ratio 50:1, and 18.9 l (5 gal) of water. The average 28-day strength values varied from 19.9 to 29.4 MPa (2,890 to 4,267 psi), with a mean of 26.4 MPa (3,835 psi).

Following initial tensioning and proof testing, a base plate was grouted in the drill hole collar, and the anchor head was positioned over the cable strands. Wedges were positioned over each strand, and strands were individually tensioned with a jack placed over the hole and the strands passing around its circumference. The final lock-off load on each strand was approximately 176 kN (39.6 kips).

The cable loads were monitored for approximately 2 months. Only one anchor required retensioning. The anchor installation was completed by severing the cables approximately 152 to 229 mm (6 to 9 in.) above the bottom so that they would be below the top of the dam. Inverted aluminum pails were placed over the anchor head recesses and then filled with a weak concrete mixture that would be easy to remove for monitoring operations in the future.

To arrest the leakage, all joints in the dam along its entire length were pressure grouted. Grout holes were drilled with an air track. A single mechanical packer was installed within each grout hole, and then the grout was pressure injected. Typically, a thin water-cement mixture of 4:1 was used to begin the

injection. Cement was gradually added (up to 1:1 mixture) if a particular section or hole continued to take grout beyond the normal or expected amount. Grouting continued until "refusal" (less than 1 gal of grout take in 10 minutes).

The pressure used to inject the grout was calculated according to depth. An additional 0.07 Mpa (10 psi) was then applied in each test grout section to ensure grout movement through potential cracks. Generally, for every 0.3 m (1 ft) of concrete above the test section, 0.007 MPa (1 psi) of grout pressure was used. Three-hundred-twenty-five 63.5-mm (2-1/2-in.) grout holes were drilled with an approximate total length of 3,810 m (12,500 ft) and a take of about 2,600 bags of cement.

The grouting program was largely successful, although there was still minor seepage occurring at the junction of the east wing wall and the east end of the penstock structure. The seepage was small and did not have a detrimental effect on the performance or stability of the dam. It is being monitored, and if a significant increase in seepage is noted, additional grouting will be carried out at this location in the future.

Because of the concerns expressed during the initial investigation about the potential deterioration of the repair concrete in the pier, additional concrete cores were recovered from these structural elements in 1986. From a nominal testing program carried out on a number of these core samples, as well as from a comparison of the physical properties of the concrete as established during the detailed investigation in 1978, it was concluded that very little further deterioration of the pier concrete had occurred since 1978. Remedial work on the pier was canceled, pending evidence of concrete problems.

## **Lake Buchanan Dam**

Lake Buchanan Dam is located on the Colorado River near Burnet, TX, about 80 km (50 miles) west of Austin. With an approximate length of 3 km (2 miles), it is considered to be the longest concrete multiarch dam in the nation. The dam provides hydroelectric power and water storage.

Construction of the multiarch dam was started in 1931 by a private utility. In 1932, the utility went bankrupt, and construction was halted. In 1935, the Lower Colorado River Authority (LCRA), an agency of the State of Texas, took over the dam and resumed construction. LCRA completed the dam in 1937.

The dam is approximately 44 m (45 ft) high with the top of the spillway at el 1,020 ft msl. The arches are sloped such that the top of each arch is located downstream of its bottom. Each arch is 32 m (105 ft) in length along its circumference and 0.9 to 1.2 m (3 to 4 ft) thick and is supported on its ends by concrete buttresses (Figure 115). The buttresses are on 21.3-m (70-ft) centers and are perpendicular to the axis of the dam. Each lift of an arch is keyed into the previous lift with the key occupying the middle third of the construction joint. Joints are perpendicular to the length of the arch and, thereby, inclined downstream from the horizontal.

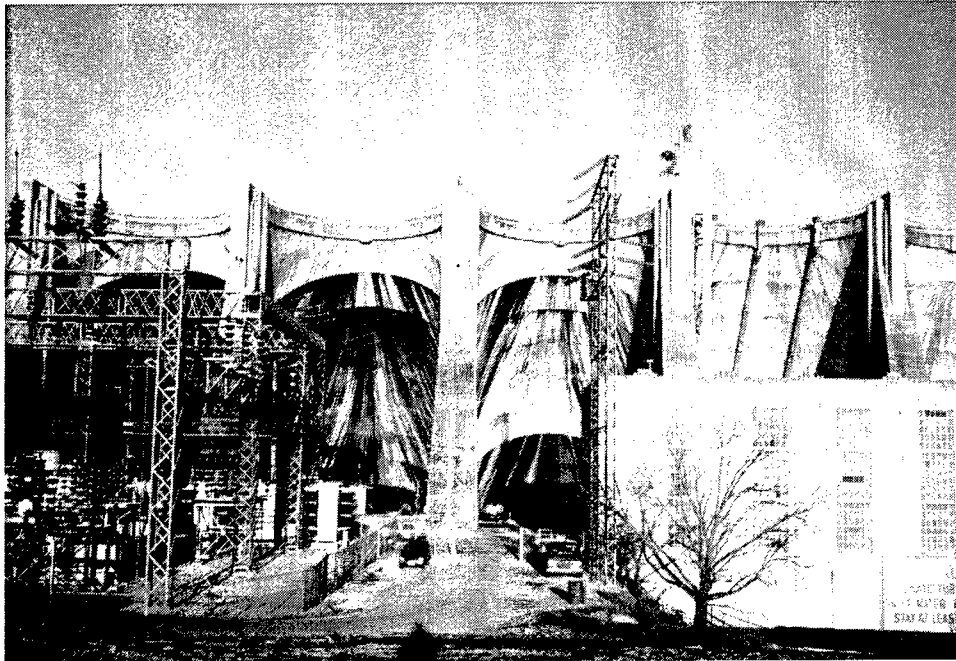

Figure 115. Downstream view of Lake Buchanan Dam

When the lake was impounded, the area between the original and later construction began leaking because of inadequate bond between the older and newer concrete, a result of the interruption in construction (Figure 116).

Although the dam was safe, LCRA wanted to stop the leaks to conserve water and improve dam appearance. Following numerous attempts to stop the leakage over the years, an effective repair method was found in 1985. Ellett (1991) described the repair. This case history is a summary of his report.

The 1985 repair method was similar to a method used earlier; the earlier repair failed because the grout injected into the joint hardened and did not move with the dam. The new repair method specified a water-activated foam, which would remain flexible and keep the voids filled as the dam expanded and contracted.

The copper-sealed construction joint between the two building phases where the leakage occurred is 9 to 12 m (30 to 40 ft) above the foot of the dam. The first step in the repair process was to install pipes to divert water from the construction joints. Workers used 15.9- by 610-mm (5/8- by 24-in.) bits to drill holes about 305 mm (12 in.) above the seam. The holes were drilled to intersect the joint almost halfway through the arch, which is 0.9 to 1.2 m (3 to 4 ft) thick. Drilling for each hole continued until the joint was intersected and water exited through the hole. A 9.5-mm (3/8-in.) pipe was then inserted into each hole and driven in with a hammer to assure a secure fit. Next, a valve was installed on the pipe and left open so water would flow through the pipe and away from the seam.

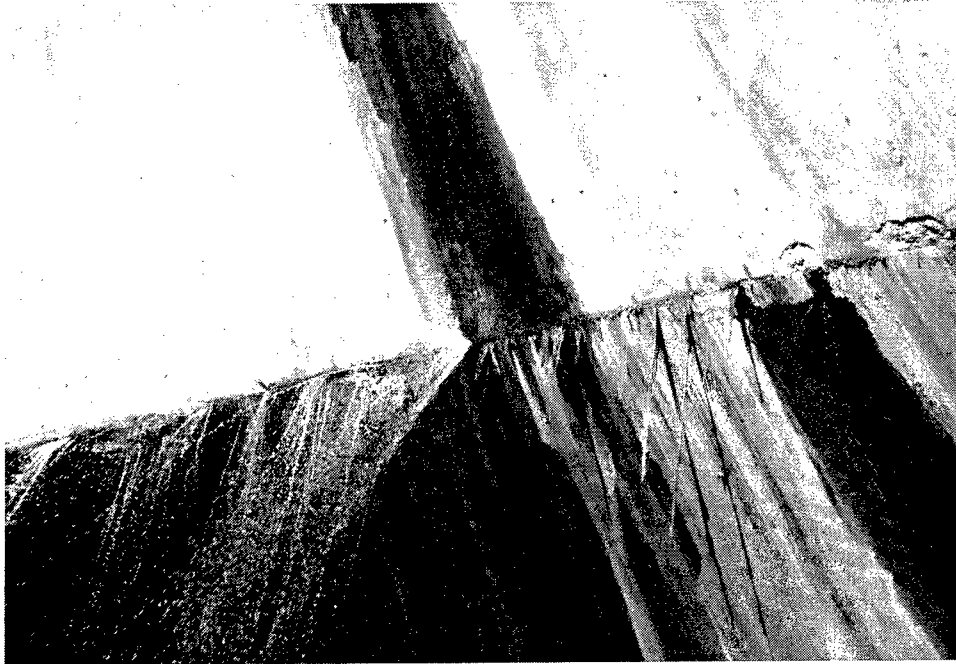

Figure 116. Joint leakage at Buchanan Dam

Lead wool and oakum were used as a temporary seal. As the seam flow was plugged, the flow of water through the pipes increased. If the increased pressure pushed the lead wool and oakum back out of the seam, more pipes were installed to relieve the water pressure. Once all water was diverted to the pipes, the water-activated foam could be injected into the joint.

Equal parts of chemical foam and water were used. The foam and water were pumped through separate hoses and mixed in a mixing manifold connected directly to the 9.5-mm (3/8-in.) pipe valves installed in the dam. A check valve prevented backflow of foam or water into the other hoses. A high-pressure pump (capable of pumping up to 34.5 MPa (5,000 psi)) with a dual cylinder was used to inject the foam into the joint.

With all valves open and water flowing, one valve on the end of the joint was turned off. A manifold was connected, and pumping began under a pressure of approximately 10.5 MPa (1,500 psi). A regulator on the pump was used to control flow pressure of the mixture into the seam (Figure 117). The foam mixture was pumped into one pipe until a milky flow was visible from the next pipe. The manifold was then connected to that pipe, and the process continued until the flow of water was stopped. The lead wool helped to keep the foam from washing out before it set. Approximately 150 to 190 ℓ (40 to 50 gal) of foam was used per joint.

Five years after the material was first used to repair the leaking joint, the repair was still performing well.

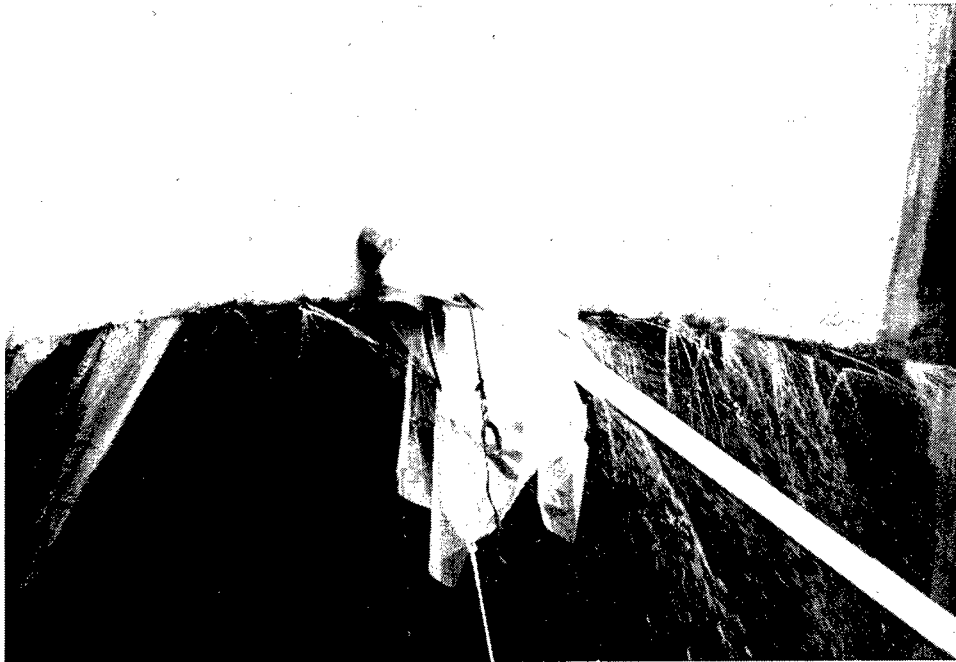

Figure 117. Injection of foam to stop joint leaks at Buchanan Dam

### **Burrinjuck Dam**

Burrinjuck Dam, originally constructed between 1907 and 1928, is located in New South Wales (NSW). The dam, which is owned by the Department of Water Resources, is a 79-m- (259-ft-) high, 230-m- (755-ft-) long monolithic concrete gravity structure. In 1956, concrete buttresses were added to the dam to strengthen it so it could provide increased storage and spillway capacity.

In the 1900s, the NSW government began a dam safety program, which involved upgrading existing high-hazard dams to meet new PMF standards. One method of upgrading the dams was to increase storage by raising the height of the dams. This method was selected because it is cost-effective and environment friendly.

In 1990, work began on a project to increase the height of the dam by 12.2 m (40 ft). An open reinforced-concrete chamber was constructed at the existing crest level of the dam, and the dam was stabilized with posttensioned ground anchor cables (Figure 118). During high flood levels, the chamber fills with water, thus providing additional stability. Two rows of posttensioned ground anchors provide a stabilizing force of 14,200 kN/m (5,240 tons/ft) for the dam. The anchor cables, each consisting of 63 strands (15.2-mm- (0.6-in-) diam) were placed on 1.5-m (5-ft) centers. To provide corrosion protection, strands were encapsulated in grease-filled polyethylene tubes above the anchorage zone, and cables in the anchorage zone and the free length of cable were installed in a single-stage grouting operation. Type G oil well cement was specified for the grout; it produced a high-strength, low-shrinkage, and low-bleed mixture. Cable load is monitored, and the anchors can be restressed if necessary.

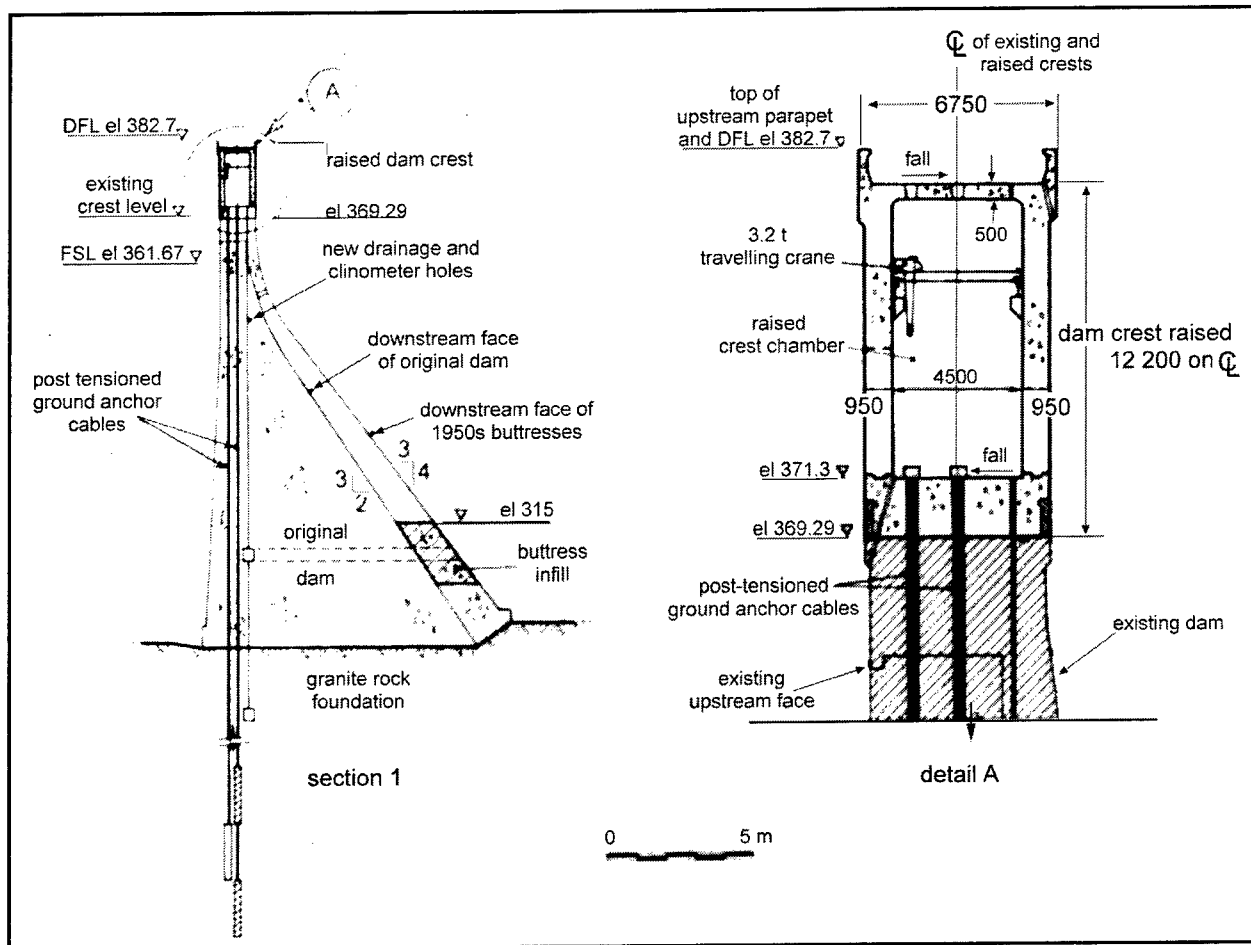

Figure 118. Section through Burrinjuck Dam, showing details of raising height of dam 12.2 m (40 ft)

To provide access for the cable installation and concrete placement, a 96-m- (315-ft-) long cantilever roadway was constructed across the northern spillway. The spillway walls were modified, and the outlet works were improved as a part of the rehabilitation. The total cost of the effort was \$119 million (Carter 1990).

### Crescent Dams

Crescent Dams are located on the Mohawk River near Albany, NY. The dams were completed in 1912 as part of the Erie Canal System. The dams consist of two independent gravity overflow sections that link each bank to an island in the middle of the river. Total length of the dams is 438 m (1,436 ft). The dams, which are curved in plan, have an average structural height of about 12 m (40 ft). Three hundred five-mm- (12-in.-) high flashboards top the crest of each dam. A river control structure located on the west bank consists of a 9-m- (30-ft-) wide tainter gate (Figure 119). The dams provide 8.2 m (27 ft) of head for the 11.6 MW hydro plant located at the site.

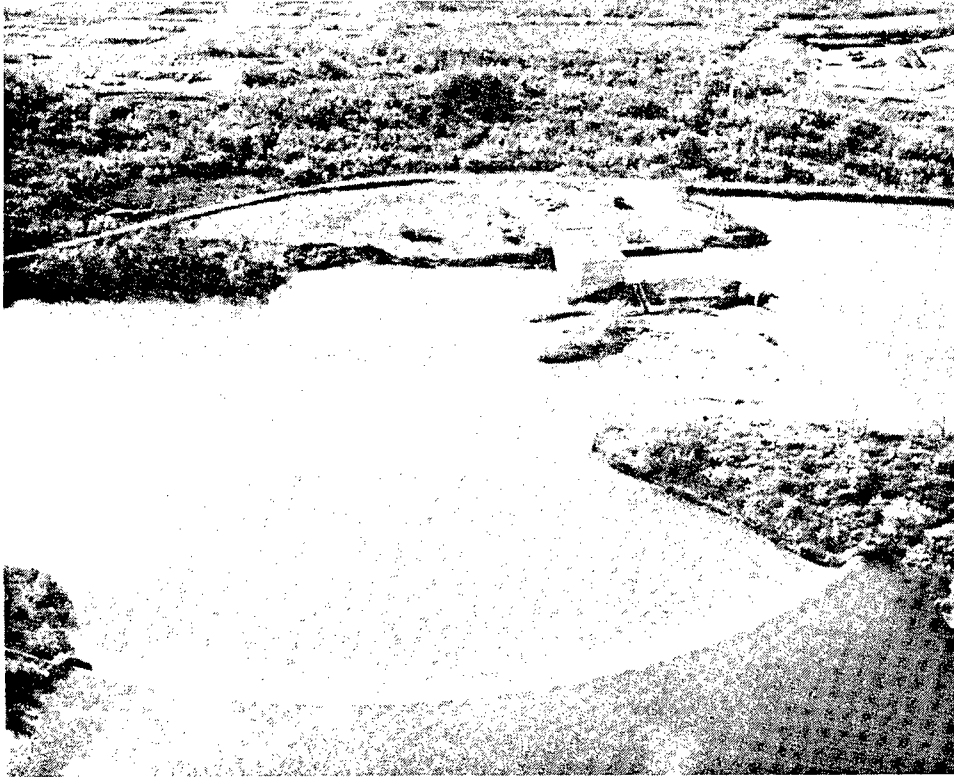

Figure 119. Crescent Dams (from Sumner, Nash, and Haag 1991)

In 1987, stability and hydraulic analyses of Crescent Dams confirmed earlier conclusions that the dams needed to be posttensioned to meet Federal Energy Regulatory Commission (FERC) safety guidelines for unusual and extreme

events. Sumner, Nash, and Haag (1991) described the rehabilitation. This case study summarizes their report.

A total of 151 anchors, ranging in length from 18 to 30 m (60 to 100 ft) were installed. Each had a design capacity of 191,416 kg (422 kips). The amount of posttensioning force required depended on the width and height of each of the 45 monoliths.

Extensive consolidation grouting and redrilling of the anchor holes were required because of poor watertightness in the bond zone. It was believed that this extra work was necessary because the anchor holes were percussion drilled instead of core drilled. During percussion drilling, 14 kg/sq cm (200 psi) of air was used to remove the cuttings. The air pressure caused openings in thin foundation rock bedding planes and cleared minor concrete cracks, resulting in subsequent water and grout loss in the bond zone. However, an economic evaluation showed that percussion drilling, consolidation grouting, and redrilling were less expensive than the slower core drilling. Also, percussion drilling left the surface of the boreholes rougher, which increased the ultimate bond strength between rock and grout. All of the posttensioned anchors exceeded test and design requirements.

Structural repairs made to the dam faces followed two underwater inspections: the first inspection gave a basis for bidding while the second (an underwater video inspection) aided the contractor in identifying specific areas to be dewatered and repaired. Portable cofferdams were fabricated and assembled onsite to dewater repair areas. On the upstream side of the dam, all repairs were within 1.5 m (5 ft) from the crest. The 1.2-m-wide by 1.7-m-deep (4-ft-wide by 5-1/2-ft-) deep by 90-m- (30-ft-) long cofferdams used in this area were fabricated to match dam contours (Figure 120). Cofferdams used to dewater the downstream toe and apron sections were 7.6 m (25 ft) wide by 4.3 m (14 ft) deep by 9 m (30 ft) long.

Crane and supply barges and push and utility boats were used to handle materials and equipment during the repair effort. Dewatering allowed for a more detailed inspection of the deteriorated areas. In general, any concrete that had deteriorated to a depth of 127 mm (5 in.) or greater was repaired. Damaged areas were excavated to sound concrete or 102 mm (4 in.) and edges were kept perpendicular to the repair surface. Repairs less than 305 mm (12 in.) deep were reinforced with 6 by 6, W4 by W4 welded wire mesh. Those over 305 mm (12 in.) were reinforced with no. 6 rebar on 305-mm (12-in.) centers. The hooked dowels were epoxy grouted into 0.6-m- (2-ft-) deep holes drilled in the original concrete. If cracking was severe enough to allow leakage, PVC pipe drains were installed to relieve hydrostatic pressure behind a fresh concrete patch and to later serve as urethane grout injection ports (Figure 121).

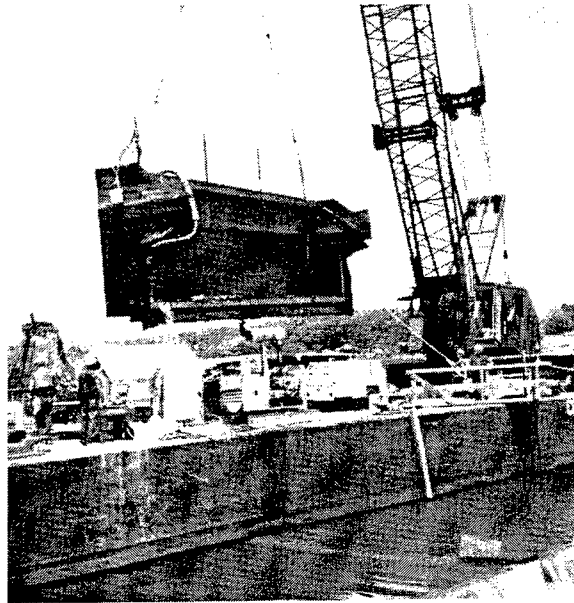

Figure 120. Portable cofferdam used upstream at Crescent Dams (from Sumner, Nash, and Haag 1991)

Rehabilitation of the dam crest consisted of placement of a 12.7-mm- (1/2-in.-) thick, 152-mm- (6-in.-) wide stainless steel plate along the entire crest length. This steel plate provided a smooth, nondeteriorating, low-maintenance surface for sealing the flashboards. The design also included revised flashboard details and the use of a “candy cane” configuration for flashboard pins.





Figure 121. Typical spillway repair in progress at Crescent Dams (from Sumner, Nash, and Haag 1991)

A 65-year service life of the tainter gate at Crescent necessitated substantial repairs to the concrete piers and the gate itself. Concrete piers were repaired using techniques similar to those described for dam repairs. In addition, corroded steel braces and approximately 35 percent of the skin of the plate were replaced, horizontal and vertical posttension anchors were installed, and a new electrically operated gear drive was placed into service. All repairs to the tainter gate were accomplished behind the earthen and cellular cofferdams constructed to dewater the gate area.

### Vischer Ferry Dams

The Vischer Ferry Dams are located on the Mohawk River near Albany, NY. The dams were completed in 1913 as a part of the Erie Canal System. The dams are two concrete gravity overflow sections that link each bank to an island. Total length of the dams is 585 m (1,919 ft); the gravity sections average 9 m (30 ft) in height. A 686-mm- (27-in.-) tall flashboard tops the dams. Because the island is slightly below headwater level, a 0.9-m- (3-ft-) tall broad crested weir was constructed on the upstream end of the island (Figure 122).

In 1987 plans were made to relocate the existing regulating structure at Vischer Ferry Dams so hydropower capacity at the dams could be increased from 5.6 to 11.6 MW. The existing river regulation structure was relocated from what is now the intake to the expansion powerhouse. After confirmation by hydraulic modeling, a replacement structure was located perpendicular to the dam, discharging from the left side of the new intake. The existing intake gates were modified and reused, and a new control system was installed to allow

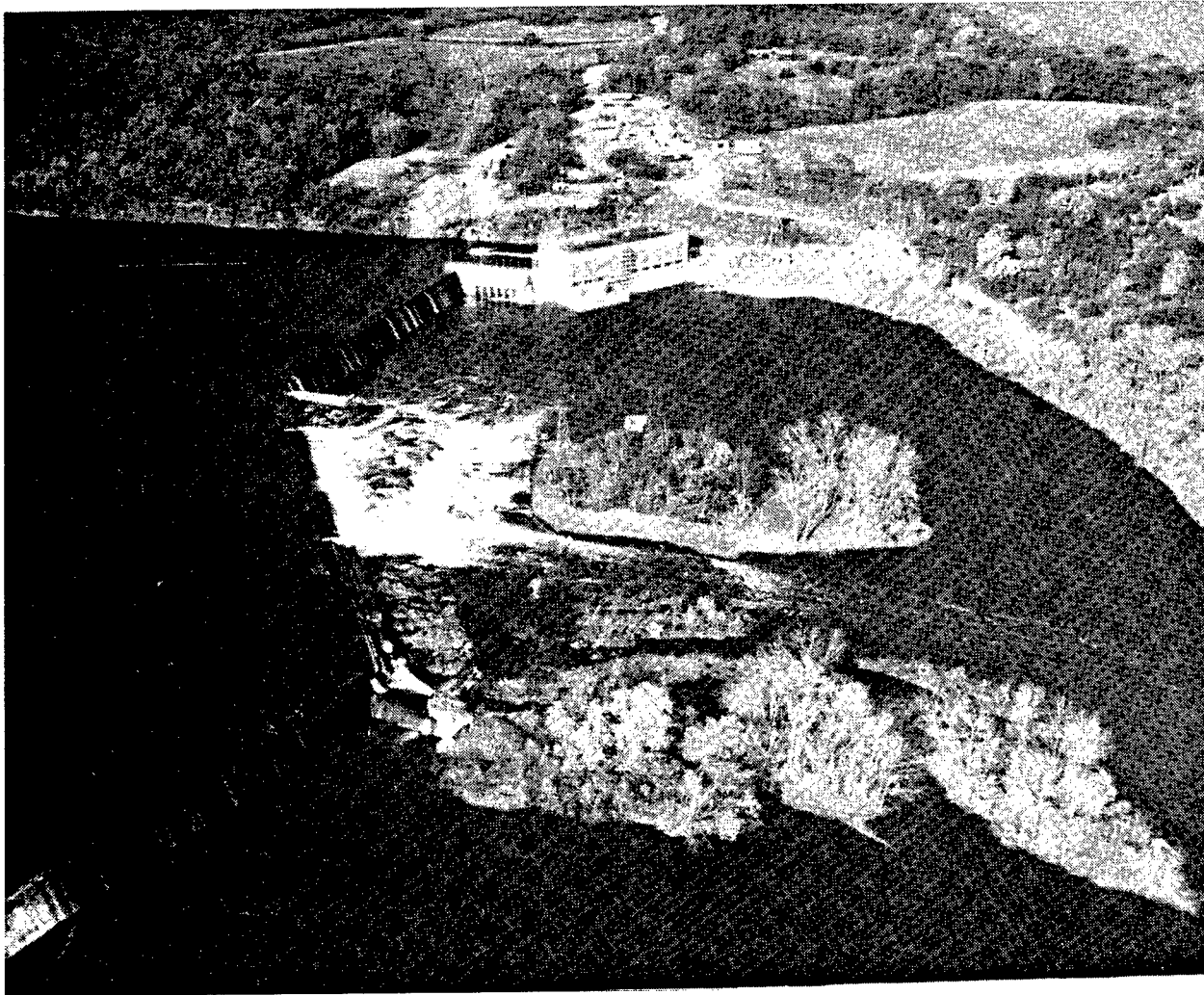

Figure 122. Vischer Ferry Dams (from Sumner, Nash, and Haag 1991)

remote operation. A new trash sluice, which is coordinated with powerhouse trash racks and rack cleaning machine, was also installed. The existing structure was removed by means of underwater demolition methods.

The pier nose at the end of the relocated regulating structure was extended to reduce head loss and eliminate the potential for water separation. The pier was constructed with precast concrete sections and tremie concrete, saving the \$160,000 additional cost of dewatering necessary for a cast-in-place extension.

Procedures used for structural repairs to the dams and rehabilitation of the dam crest were identical to those used at the Crescent Dams and described in the previous section (Sumner, Nash, and Haag 1991).

## Daniel Johnson Dam

Daniel Johnson Dam is located on the Manicouagan River in Quebec, Canada. The 204-m- (703-ft-) high multiple arch dam, which is owned by Hydro-Quebec, impounds a 141.9 billion cu m (115-million acre-ft) reservoir. Each arch of the dam was constructed with 12 columns that were cast in vertical lifts and then grouted together to form a monolithic buttress.

During the winter of 1980, blasting for the construction of a new four-unit powerhouse at the site was interrupted when cracks were discovered in the downstream face of the dam. A team of experts determined the cracks could have been caused by the high-pressure cleaning method used to remove construction debris from the face drains that run between inspection galleries, by pressures from the grout injection of the columns that make up the arches, or from cycles of freezing and thawing. Large cracks were drilled and grouted, and thin cracks inside the dam were sealed with epoxy (*ENR* 1981).

In 1990, following extensive field measurements and analytical studies to evaluate the structural behavior of the dam and to ascertain the cause of the cracks observed on the faces of the arches, work was begun on the construction of nine tent-like structures to provide thermal protection for the lower portions of the smaller arches. Analytical studies concluded that the downstream cracks were caused by severe winter temperatures and cracks on the upstream heels of the arches were caused by stress concentrations due to a discontinuity in geometry. The studies further indicated that the load-carrying capacity of the dam had been only slightly affected by the thermally induced cracks, and the dam was judged to be structurally stable. Thermal protection was therefore recommended to prevent further cracking.

The structures consist of steel frames covered in layers of reinforced insulating sheets. In winter, heaters are used inside the structures to maintain a temperature of 5 to 10 °C (23 to 50 °F) (*Water Power & Dam Construction* 1990).

## Delta Dam

Delta Dam is located on the Mohawk River about 6 km (4 miles) north of Rome, NY. The 30-m- (100-ft-) high, 305-m- (1,000-ft-) long cyclopean masonry dam has a 91-m- (300-ft-) long uncontrolled spillway and four low-level outlet pipes discharging into the stilling basin downstream of the structure. Problems at the site were evident in 1913, when the dam was completed. A high-water-content concrete had been used in construction to fill voids between the cyclopean stones. Leaching from the concrete left carbonate deposits on the outer surface of the dam and on the joints between adjacent monoliths. This leaching caused the concrete to deteriorate.

The disintegration of the dam faces caused citizens of Rome to be concerned about the stability of the dam, so an inspection was conducted in 1924. The subsequent inspection report carried recommendations for placing new masonry on the upstream and downstream faces of the dam, grouting to stop interior

leakage, improving sliding stability of a portion of the spillway, installing a grout curtain in the foundation rock, and installing a drainage system to relieve uplift pressures.

Repairs since the inspection consisted of the following: in 1924, partial grouting of the dam body was accomplished. In 1925, a reinforced concrete lining was placed on the upstream face of the dam, the foundation area was grouted, and a concrete thrust block was placed over the western half of the downstream edge of the spillway apron. In 1956, concrete on a portion of the downstream face below the gate house was removed and replaced with gunite, and some portions of the dam were grouted. In 1958, the entire downstream face of the dam was resurfaced with gunite, and wrought iron nosing was installed on the gatehouse intake piers. Concrete deterioration continued despite these repair efforts.

In 1978, the USACE sponsored inspections of non-Federal dams as part of the National Dam Safety Program. Delta Dam, which is owned by the New York State Department of Transportation (NYDOT), was evaluated according to the Phase I guidelines set by the USACE. The inspection report recommended that the condition of the dam be evaluated further and that the stability of the dam be improved to meet modern design flood criteria. Standig (1984) described the rehabilitation plan for Delta Dam. This case history is a summary of his report.

In 1979, NYDOT hired a private firm to do a detailed inspection of the dam and to make specific recommendations for rehabilitation of the structure. Engineers reviewed the hydrologic capacity and stability of the structure when placed under updated design criteria and evaluated the extent of concrete deterioration. Based on this study, they recommended that posttensioned anchors be installed to improve the stability of the dam, both the upstream and downstream faces of the dam be repaired, and portions of the dam be grouted. A contract for the rehabilitation work was awarded in 1982 (Standig 1984).

The system of posttensioned anchors included 93 anchors on 1.8-m (6-ft) centers in the spillway section, where the greatest strengthening was needed, and on 4.6-m (15-ft) centers in the abutment areas. The steel strands specified for the anchors had a guaranteed ultimate tensile strength (GUTS) of 186 kN/sq cm (270 ksi). The design load of each anchor was based on 60 percent GUTS of the material but was actually locked off at 70 percent GUTS to account for losses from creep in the rock and relaxation of the steel strands. Each anchor was stressed to a proof load of 80 percent GUTS during installation to ensure that the lower anchorage could transfer the load to the rock. The strands were installed with double corrosion protection consisting of a plastic duct and grouting. The grouting system included simultaneous tremie-placement of grout both between the strand and casing and the casing and anchor hole. Anchor embedment depth ensured resistance of the lower anchorage to applied upward pull. In the free length of the anchor, the smooth duct and a grease and plastic coating on the strands kept the strands from bonding to the grout. Figure 123 shows the anchor detail.

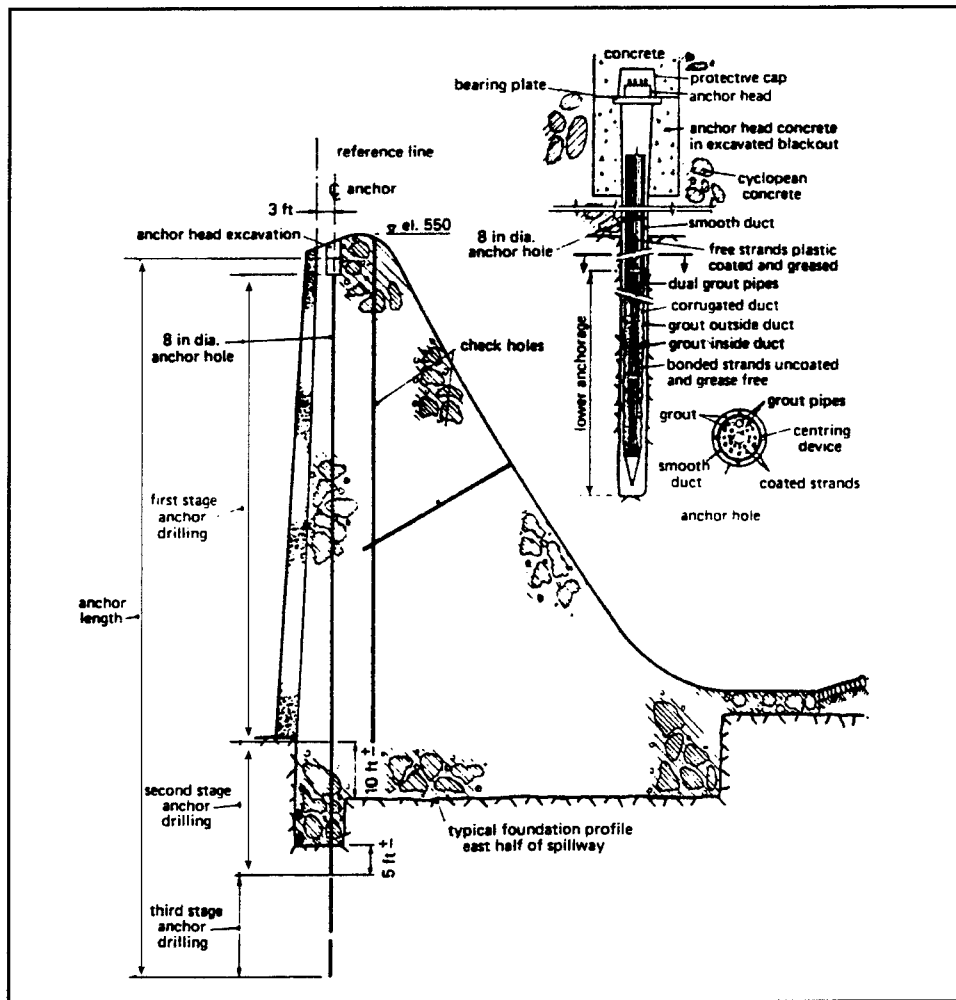

Figure 123. Details for installation of posttensioning anchors at Delta Dam (from Standig 1984)

Each anchor hole was drilled in three stages: the first stage to within 3 m (10 ft) of the concrete rock interface; the second stage to 1.5 m (5 ft) below the interface; the third stage to the final anchor depth. Water-pressure tests performed after each stage of drilling identified the region of water loss. When drilling was completed, anchor holes that failed the watertightness specification were tremied with Portland cement grout. A thin mixture was used for small cracks and a thicker mixture for large voids. Grouted anchor holes were redrilled and retested to the same watertightness specification. Small-diameter check holes were drilled into the dam and pressure tested to determine the effectiveness of the grouting of the anchor holes. These check holes were then grouted.

The first step in resurfacing the downstream face of the dam was to remove the deteriorated surface, including gunite from pervious repairs and some original concrete, to sound concrete; the average removal depth was approximately 0.3 m (1 ft). A 457-cm- (18-in.-) thick reinforced concrete overlay was then installed on the downstream surface. The overlay was placed in alternate

9-m- (30-ft-) wide panels with vertical construction joints that matched the existing monoliths. The panels were bonded to the existing concrete with hooked dowels that were grouted into the existing concrete. A waterstop and underdrain were installed at each contraction joint; underdrains were also placed below horizontal construction joints. The spillway crest was reshaped to conform to the revised hydraulic standards for overflow structures.

Specifications for the concrete used in the overlay included the use of air-entrainment to increase resistance from cycles of freezing and thawing, a low w/c to produce a dense concrete and reduce shrinkage, and restrictions on component materials that could cause alkali-aggregate reactivity and chloride attack on reinforcement. Also, curing of the concrete was carefully controlled to prevent shrinkage and cracking.

Concrete damage on the upstream face was characterized by excessive leaching and honeycombing around improperly constructed horizontal joints. The deterioration was the result of cycles of freezing and thawing of the poor quality concrete in the zone affected by the rise and fall of the reservoir. These drummy areas were removed and replaced with a durable concrete mixture.

During the rehabilitation design, a problem was discovered at the gate house. There were vertical cracks in the walls between adjacent gate wells. These cracks, which extended over the full height of the walls, were located in line with the dam axis. The cracks had to be repaired before any anchoring was performed in the area to prevent aggravation of the situation as a result of the posttensioning operation. From the downstream face of the dam, bar anchors were installed horizontally across the plane of the cracks to "stitch" the sides of the cracks together. Existing voids in the body of the dam were grouted before the cracks were filled and rebonded by epoxy injection. Finally, the bar anchors were stressed to put the plane of the cracks in compression before the rock anchors were installed.

## **Easton Dam**

Easton Dam, which is owned and operated by Bridgeport Hydraulic Company, Connecticut, was completed in 1926. The original concrete gravity structure was 37.5 m (123 ft) high and 317 m (1,040 ft) long with a 12-ft wide crest. The 30.5-m- (100-ft-) long spillway has a ogee crest. The dam was constructed with 16 vertical construction joints.

The USACE inspected the dam in 1978. The inspection team identified areas of surface and joint spalling, deterioration on the crest and crest overhang, and railing anchors pulled from the concrete. There was also seepage and efflorescence along some of the vertical construction joints.

Seasonal leakage patterns indicated the possibility that the structure had not been constructed with waterstops, or that, if it had been, they had deteriorated under repeated cycles of expansion and contraction. The primary cause of

deterioration was identified as freezing and thawing of the reservoir leakage on the downstream face and ponding on the crest. Bernard (1989) described the repairs made to Easton Dam. This case history is a summary of his report.

Core samples revealed that visible deterioration was as deep as 152 mm (6 in.). An underwater inspection showed that concrete and joint deterioration was limited to the upper 7.6 m (25 ft) of the dam. A decision was made to seal the vertical joints with a chemical grout and to install joint waterstops 10.7 m (35 ft) below the top of the dam.

After conducting a literature search, obtaining information from grout manufacturers and installers, and the USACE, engineers for the project selected a urethane-foam-type grout as the filler material. These two-component chemical grouts expand up to eight times their volume upon contact with water. Urethane grout waterstops were installed during the fall and winter of 1983. Cost was \$97,000.

To seal the vertical construction joints, technicians drilled 152-mm- (6-in.-) diam holes 10.7 m (35 ft) deep or 1.5 m (5 ft) into bedrock, depending on whether they encountered bedrock. The holes were located 0.6 to 0.9 m (2 to 3 ft) from the upstream face and centered over each of the 16 vertical construction joints. Down-the-hole closed circuit video equipment was used to ensure the holes were drilled over the construction joints. A temporary joint sealant approved for potable use was applied underwater to the upstream face to prevent the grout from escaping through the joint into the reservoir water.

Although this was not the first time urethane grout had been used to seal leakage, the drill holes for this project were longer and larger than those for any previous application, so a new installation method was used. Rags soaked in the grout were stapled to sections of 51-mm- (2-in.-) diam perforated PVC pipe, and the pipe was twisted down the hole. Once a pipe section was placed to just above the grade of the dam crest, it was coupled to the next section so that placement could continue. Seepage was reduced by 80 percent.

Repairs to the dam crest consisted of removing deteriorated concrete and replacing it with reinforced concrete. The deteriorated concrete was removed by hydrodemolition. To ensure durability of the concrete, a mixture with a compressive strength of 34.8 MPa (5,000 psi) at 56 days was specified. An elastomeric sealant was used at the joints to keep water from entering. The steel reinforcing was coated with epoxy to prevent future deterioration. Dowels were used to anchor the new concrete to the existing concrete, and hooked bars were installed on each monolithic section at construction joints to control curling. To provide the specified depth of cover for the reinforcing steel, the concrete overlay was 229 mm (9 in.) deep. According to calculations, the higher crest would have no adverse effect on the stability of the dam.

Additional improvements included, widening the cap and installing rails to the outside faces. The crest was sloped away from the vertical construction joints and the downstream face to eliminate standing water. A cantilever

section was installed where the upper gate house extends into the crest; this section facilitates heavy equipment traffic.

With completion of these repairs in 1988 at a cost of \$700,000, repairs to the downstream face became less urgent and were postponed to allow for further structural monitoring.

## Fuelbecke Dam

Fuelbecke Dam is located near Altena, Germany. The dam, which was completed in 1896, is 29 m (95 ft) high and 145 m (476 ft) long. When the dam was refurbished recently, the local water authority requested that durability and reduction of surface blemishes, or blow holes, be given priority, so the contractor, a concrete specialist, recommended that Zemdrain be used to line the formwork for the upstream face of the dam. This case history is a summary of "Permeable Formwork Liner for German Dam Repair" (*Water Power & Dam Construction* 1991).

Zemdrain is a permeable, 0.7-mm- (0.028-in.-) thick, 100 percent thermally bonded polypropylene fabric that allows air and water to enter its matrix but not cement particles. Natural hydrostatic head within the wet concrete along with internal vibration cause the air and water to pass through the liner (Figure 124).

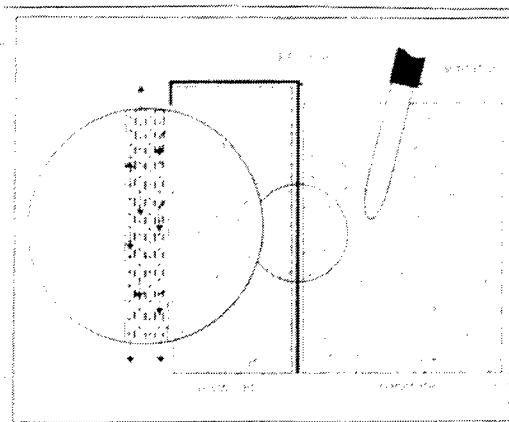
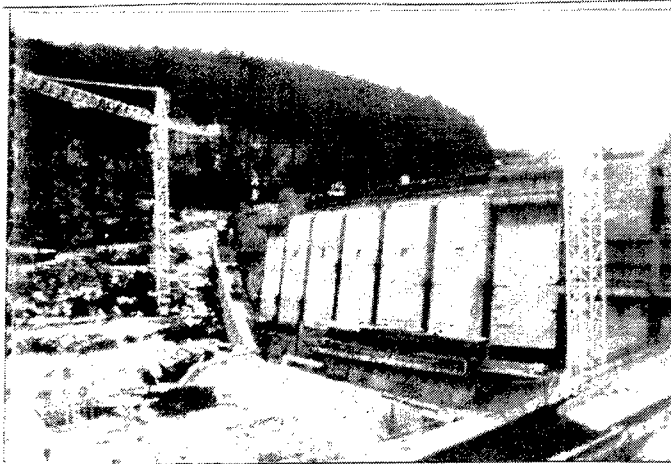

Figure 124. Permeability control with Zemdrain liner used at Fuelbecke Dam (from *Water Power and Dam Construction* 1991a)

When Zemdrain is attached to the inside of a steel or timber shutter, air that would normally form pockets at the concrete/shutter interface exits through the liner. In a similar manner, water near the concrete/shutter interface leaves the surface zone and drains to the bottom of the shutter, thus significantly reducing the w/c in this region.



Results of tests conducted for the Fuelbecke project were similar to those of earlier tests done by Taywood Engineering Ltd., United Kingdom, show that the use of Zemdrain creates a surface that is free from blow holes and that has a harder cover zone (Figure 125). Also, initial surface absorption and concrete permeability are greatly reduced, thus increasing resistance to cycles of freezing and thawing and aggressive environments.

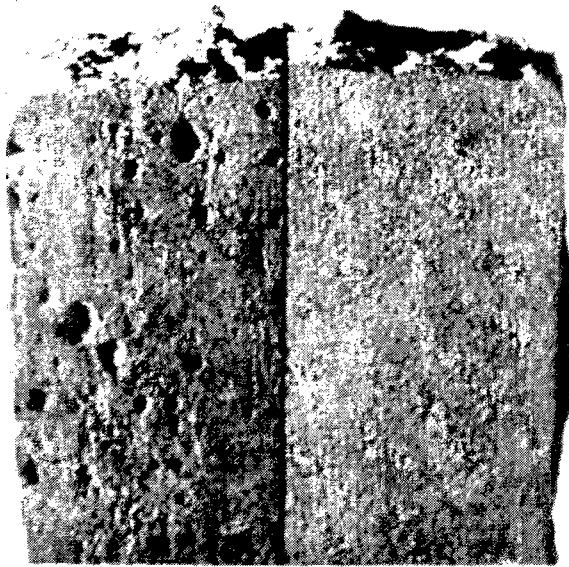

Figure 125. Test specimens showing concrete placed with conventional formwork and formwork lined with Zemdrain (from *Water Power and Dam Construction* 1991a)

The use of Zemdrain requires no major changes in construction procedures. Before the shutter is placed, the liner is installed on the inside face of the shutter. It is held in place with tensioning springs and staples, which keep the material taut so as to prevent surface deformations in the finished product. Once the shutter is placed, work continues as usual.

Use of the Zemtrain liner did increase rehabilitation costs considerably; however, the extended life of the dam and the reduction in maintenance costs will offset this initial expense. Also, construction costs were reduced because the shutter did not have to be cleaned and striking times were reduced. Estimated payback time for the use of the liner at Fuelbecke Dam is only a few years because of reduced maintenance costs alone.

The Fuelbecke project was not the first time Zemtrain was used, but it is thought to be the largest. Zemtrain had been used at Ataturk Dam in Turkey, for wave walls at several locations along the North Sea, and for some canal and lock rehabilitation projects in Germany.

### **Glines Canyon Dam**

Construction of Glines Canyon Dam was completed in the 1920s. From the time of completion, water leaked in the outlet tunnel past the head gate structure. An underwater inspection performed in 1987 with a remotely operated vehicle revealed leakage at original construction cold joints and at cracking around the gate area. Belcher (1989) described the repairs made in 1988. This case history is a summary of his report.

The repair work was scheduled to coincide with a scheduled outage for planned repair and service of the powerhouse in the fall of 1988. Epoxy injection was selected for the repairs because of its strength, durability, and previous success in underwater repairs. Repairs at Glines Canyon Dam included sealing the cracks and joints to arrest water leakage and refurbishing the concrete liner.

With the exception of the ladder well, the tunnel downstream of the head gate was prepared in the dry for later underwater repair. Preparation included removing loose concrete, cleaning cracks, drilling and installing ports, and sealing cracks with hydraulic cement. The locations of these areas for later repair were noted on drawings for easy diver identification and relocation.

Equipment and materials for the repair were situated between the left abutment and dam crest and the ladder well. Repair personnel entered the penstock from below the vent tower and walked up the penstock to the head gate area. They were assisted through the 762- by 762-mm (30- by 30-in.) square ladder well shaft by personnel working above the gate house. Lighting and a hard-wire voice communication system were "snaked" down the ladder well to the repair area, and an electrically operated winch and pulley were used to lower and raise materials in the shaft.

The procedure used for the underwater crack repair was as follows: cracks, voids, spalls, and other damage were located and described; and algae and loose concrete were water-blasted from the repair area. For crack repairs, injection ports were drilled and installed and then the surface of the cracks between injection ports were sealed with hydraulic cement. For voids and pocket repairs, injection ports were inserted, and then the voids were hand-packed with hydraulic cement flush to the surface.

Injection began on the upstream side of the gate. The ports were injected with epoxy. Adjacent ports that showed epoxy return were plugged. The areas behind the sealed cracks and cement-filled voids were checked to verify epoxy placement.

To permit a good flow of epoxy material into the cracks in the cold underwater concrete, workers circulated warm water from the surface pumping station down an insulating and protective fire hose sleeve around the epoxy hoses to the diver's mixing head. A portable, diesel-fired water heater and electric pump kept the temperature of the epoxy high enough to ensure good flow.

The damaged area was successfully penetrated with 198 ℓ (50 gal) of hydraulic cement and 102 ℓ (27 gal) of injection material. The repair was considered sound.

## Haweswater Dam

Haweswater Dam, owned and operated by the North West Water Authority, is located near Shap in Cumbria, United Kingdom (UK). Constructed between 1931 and 1942 to supply water to Manchester, the dam is 27.5-m- (90-ft-) high and 470-m- (542-ft-) long. It is a hollow, concrete-buttress structure with continuous upstream and downstream faces. Fillets were used on the forms during casting to make the faces look as if they were constructed of large concrete blocks. Problems and repair methods used at Haweswater Dam were reported by *Concrete* (1989) and *Water Power & Dam Construction* (1989). This case history is a summary of information from these sources.

Surface spalling of the downstream face of the dam was first observed in 1971. The cause of the spalling has been attributed to excess moisture, a result of the installation of security doors within the dam structure, following perceived terrorist threats in the early 1970s. Moisture enters the dam through construction joints in the downstream face (waterstops and sealants were used only in the central spillway section), as seepage through the upstream face, and from internal drains. The security doors restricted the free flow of air through the internal chambers, so humidity within the dam remained high and the interior concrete surfaces were constantly saturated, and, therefore, subject to deterioration caused by cycles of freezing and thawing. The spalling, which continued to increase, seemed to accelerate in 1975. Most of the deterioration was located in the lower two-thirds of the dam; penetration in some areas was 100 mm (4 in.).

In 1982, three repair systems were selected for testing: each used a repair mortar with a sealer coating; two used acrylic sealants and the other an epoxy. Test repairs made with the acrylic sealants were inconclusive; the test repair with the epoxy sealant failed.

In 1985, louvers were installed on the security doors. This step reduced humidity and lowered saturation levels of the internal concrete surfaces. However, the spalled concrete still needed to be repaired, so further testing was conducted with materials similar to the acrylic-sealant systems. Three 10-m (33-ft) sections were used for the tests. All systems were applied by one contractor to increase the reliability of comparisons. Minor cracking, which was attributed to fine cracks in the original concrete, occurred on all three test panels. Two of the test sections exhibited crazing, which allows moisture to penetrate the repair mortar. The crazing was thought to be caused by shrinkage of the repair mortar. All materials used on the third panel were judged satisfactory. These materials, therefore, formed the basis for the selection of materials for the permanent repair.

The Fosroc system (Fosroc Focus 1990) selected for permanent repairs consists of Renderoc, a cementitious mortar; Renderoc FC, a cementitious fairing coat; and Nitocote Dekguard, a penetrating, silane-impregnated primer that becomes part of the concrete. (The fairing coat used in the first test was a

render layer of Renderoc, but the FC version was developed prior to full repair and was tested and approved in 1987. Joints between the repaired blocks were sealed with polyurethane sealant during the trial; this practice was carried over to the repair effort.)

Work was performed from power-operated cradles (Figure 126). Repair areas were first cleaned with air chisels, high-pressure water jets between 27.6 and 41.4 MPa (4,000 and 6,000 psi), and sand blasting. These methods enabled workers to remove spalling to depths of 100 mm (4 in.). The repair-mortar was mixed with water in a forced-action mixer and applied by

hand to the entire downstream face on one side of the spillway. The fairing coat was then applied to areas that did not need repair so they would be receptive to the overall sealing coats. The silane-impregnated primer was applied with a low-pressure back pack spray unit that floods the surface to ensure full absorption, and then a methacrylate top coat was applied with a high-pressure spray unit. In addition, all joints not sealed during original construction will be sealed with a polyurethane sealant.

The entire surface area of the downstream face of the dam, 10,300 sq m (12,320 sq yd), was coated during the repair project. Cost of the work was approximately 450,000 pounds.

### Hoist Dam

Hoist Dam, which was completed in 1925, is located on the Dead River in the Upper Peninsula of Michigan. The dam consists of a 137-m- (451-ft-) long concrete gravity-arch overflow section in the river gorge with thrust blocks on both abutments; a nonoverflow gravity section is located at each abutment, a 387-m- (1270-ft-) long section on the east and a 192-m- (630-ft) section on the west that extends into a 381-m- (1250-ft-) long earth dam. Maximum height of the dam is 19.8 m (65 ft) and crest width is 2.4 m (8 ft). The spillway, which is located on the east side of the gravity-arch, has a 30-m- (99-ft-) long section with an ogee crest that is about 0.3 m (1 ft) lower than the adjacent overflow section of the gravity-arch. The upstream faces of the gravity-arch sections are vertical; the downstream faces are vertical from the top to el 1,345 and are then sloped 0.625:1.

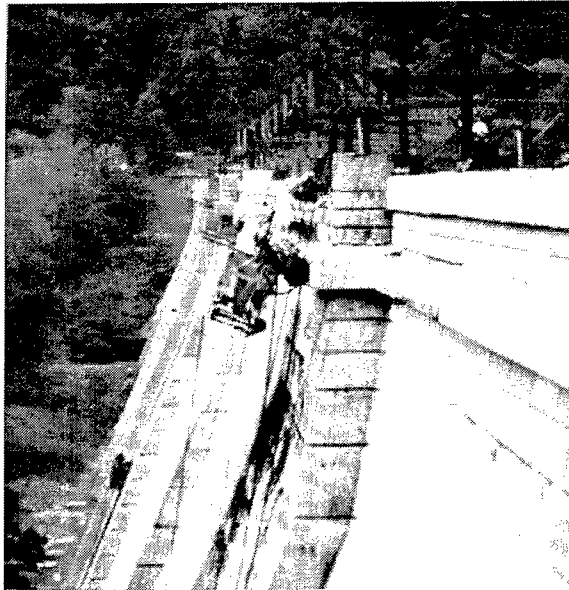

Figure 126. Power-operated cradles used for making repairs to downstream face of Haweswater Dam (from Fosroc Focus 1990)

Because of the dam's location and its having been constructed before the development of more durable concretes, Hoist Dam suffered from extreme weathering. Beginning in 1948, a number of repairs were made to areas of severe concrete deterioration. However, in 1971, Cliffs Electric Service, owner and operator of the dam, began a regular repair program because of the severe deterioration of concrete on the downstream face of the dam (Figure 127). As a part of the program, the Michigan Department of Natural Resources conducted a thorough inspection of the dam from 1974 to 1975. Following that inspection, Cliffs Electric Service hired an engineering firm to inspect the dam and provide an engineering report on its safety. Mass and Meir (1980) reported the inspection results and the repair of Hoist Dam. This case history is a summary of their report.



Figure 127. Deterioration on downstream face of Hoist Dam (from Mass and Mier 1980)

This inspection included a review of available information on the design and construction of the dam, a visual inspection, a review of repair work in progress, drilling and testing of core specimen, and an evaluation of concrete conditions.

Little information on the design and construction of the dam was available; however, several drawings of cross sections and the construction site plan, and some general notes on design features, construction joint treatment, lift height, monolith width, and special reinforcement were found. The visual examination of the structure showed severe concrete weathering and erosion. Cores were taken to determine the depth of deterioration and the condition of interior concrete. Petrographic examinations and laboratory tests were made on these core specimens. The study showed that complete restoration would require an

average of 0.4 m (1.2) ft of concrete replacement on the upstream face and 0.7 m (2.3 ft) of concrete replacement on the downstream face. The interior concrete was not of first quality, but if protected from exposure by a high-quality concrete exterior, further deterioration would be minimized, and the structure could provide many years of continued service.

Repair work consisted of drilling and grouting the left gravity wall and removing and replacing deteriorated concrete on the upstream and downstream faces. Repairs were made on the worst area first. Surface repair work was performed according to water levels in the reservoir. During late fall and winter when the reservoir was at minimum elevation, work was done on the upstream face. When the water level rose in the spring, work was moved to the downstream face. The downstream work on the sloping face was done in strips or panels (Figure 128) as opposed to the patch work on the upstream face (Figure 129).

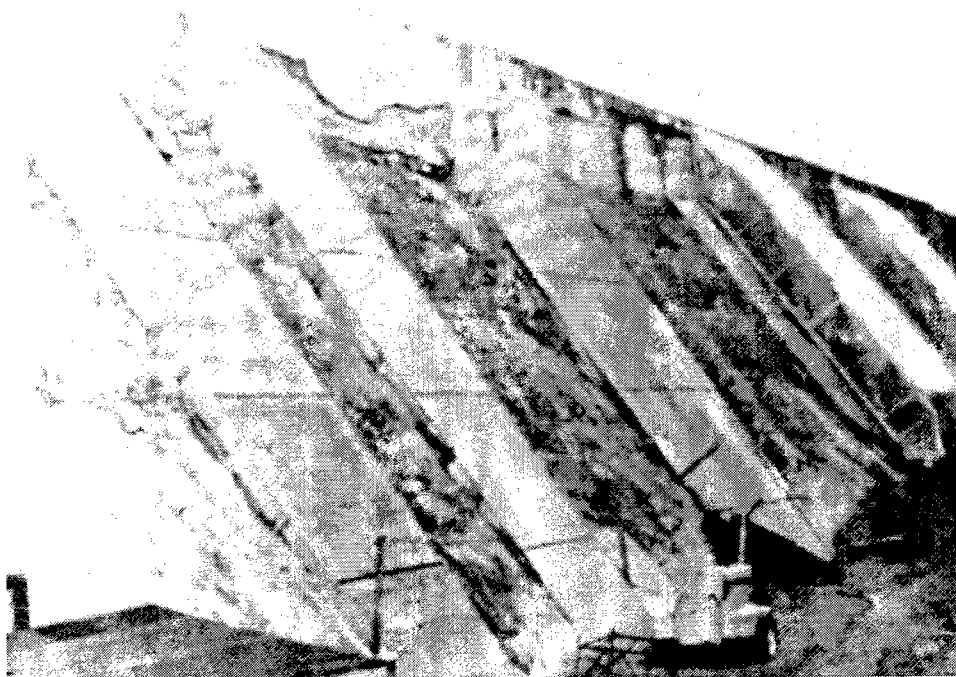

Figure 128. Repair work underway on downstream face of Hoist Dam (from Mass and Mier 1980)

During 1973, the first 61 m (200 ft) of the left gravity wall was grouted. Fifty-five vertical 38-mm- (1-1/2-in.-) diam holes were drilled to their ultimate depth. The holes were drilled on 0.6-m (2-ft) centers and staggered from 1.2 to 1.8 m (4 to 6 ft) from the upstream face, starting from the stoplog slot and working in an easterly direction. A packer was used to grout the holes; grouting began at the bottom.. The grout mixture consisted of neat cement, water, and intrusion aid. The w/c varied from 0.88 to 0.54 by weight. Grout take ranged from 85 to 981 kg (188 to 2,162 lb) of cement per hole with an average take of 443 kg (978 lb) of cement per hole.

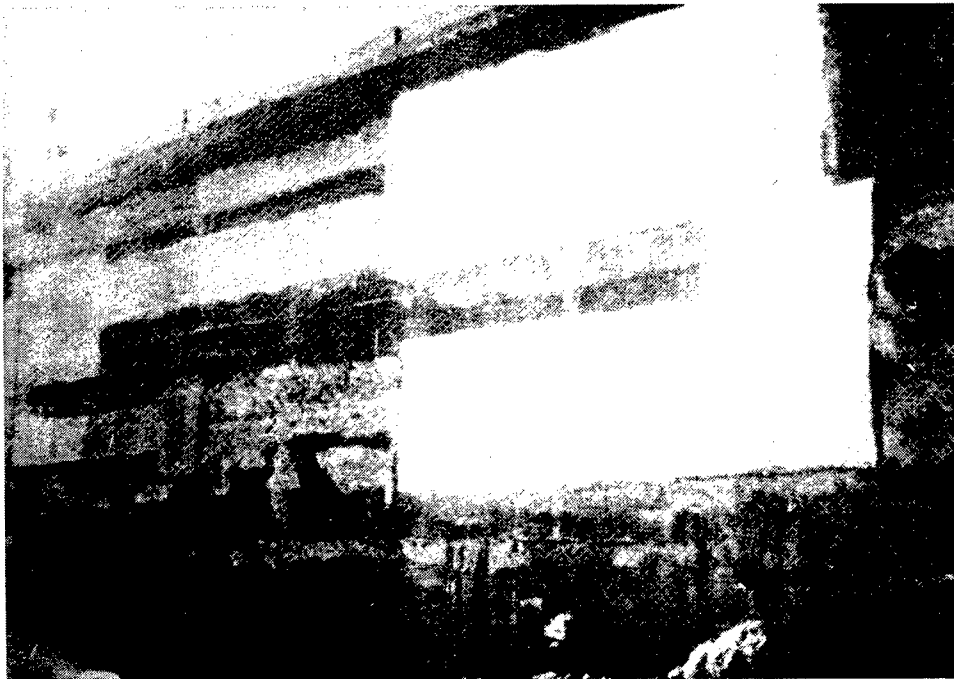

Figure 129. Patchwork repairs on upstream face of Hoist Dam (from Mass and Mier 1980)

The repair procedure for surface deterioration consisted of removing deteriorated concrete to sound concrete; grouting cracks and joints in the exposed surface; installing anchors, temperature and shrinkage reinforcement, and a copper waterstop; and placing preplaced-aggregate concrete. Temporary shelters of plastic sheeting were constructed around the repair areas during the winter months for protection of the workmen and concrete work.

Shallow cracks and joints on the upstream face were drilled and grouted. The amount of this work in each repair area was dependent on the condition of the exposed surface. Grout takes averaged 0.006 cu m (212 cu ft) at 24.2 kg (53.3 lb) of cement per 0.09 sq m (1 sq ft) of repair.

Dowels were installed in drill holes to anchor the reinforcing mat. The 19-mm- (3/4-in.-) diam dowels were placed on 0.6-m (2-ft) centers and grouted 0.6 m (2 ft) deep. Form anchors were drilled and grouted at various spacings depending on the height of the form. The reinforcing mat consisted of no. 5 reinforcing bars on 305-mm (12-in.) centers each way.

A V-shaped copper waterstop was installed in the upstream face at the vertical construction joints between monoliths. A V-groove strip was placed on the form to create a plane of weakness at the location of the water stop so that any subsequent crack would occur at the water stop. Reinforcement did not cross the joint location.

Wooden forms for placement of the preplaced aggregate concrete were installed around the perimeter of the repair and caulked to prevent grout leakage.

The facing form was then set in place. The form was filled with clean, well-graded coarse aggregate obtained from a local quarry. The coarse aggregate was crushed rock with a maximum size of 38 mm (1.5 in.) graded to 19 mm (3/4 in.). Once the aggregate was placed, a sand-cement grout was pumped into the form from the bottom corner. The grout consisted of Type I portland cement, fly ash, sand, intrusion aid, and water. A nozzle was inserted through each hole of a 610-mm (24-in.) on-center grid of holes in the form. As the grout advanced to adjacent holes, the nozzle was removed, the hole plugged, and the nozzle inserted into the next hole.

Repairs on the upstream face were cured by leaving forms in place for 7 days. Repairs on the downstream face were water cured for a period of 7 days. A total of 1,338 sq m (14,400 sq ft) of the upstream face and 752 sq m (8,100 sq ft) of the downstream face was repaired.

### **Humphreys Dam**

Humphreys Dam is located on Goose Creek in the San Juan Mountains in southwest Colorado about 11 km (7 miles) upstream of the confluence with the Rio Grand River. The 25.9-m- (85-ft-) high concrete arch dam has a crest length of 56.7 m (186 ft). The dam is 1 m (3.5 ft) thick at the crest and 5 m (16 ft) thick at the base. The spillway is a concrete gravity structure located about 30.5 m (100 ft) north of the left abutment. The spillway crest is an uncontrolled ogee weir about 21 m (70 ft) long. The outlet works is located under the center of the arch dam. It consists of two riveted steel pipes embedded in concrete and a bedrock plunge area. The inlet works, a reinforced concrete box structure, is protected by trashracks.

The dam was completed in 1924 to create a scenic and recreational lake on COL A. E. Humphreys's 3,440 sq m (850-acre) wilderness ranch. The remote location, rugged terrain, and harsh weather created problems during construction, which began in May 1923, continued through the winter, and was completed the following May.

The original design called for the upstream face of the dam to be waterproofed. However, the reservoir was filled before the waterproofing was applied. Four years later, in 1928, records show that leakage through the dam was noted. The seepage, which appeared to occur through the vertical construction joints, along horizontal lift lines, and at cracks, was attributed to inadequate concrete protection from freezing during construction and improper joint preparation during concrete placement. The leakage continued over the years in spite of numerous attempts to correct the problem. The continuous presence of water on the downstream face during cycles of freezing and thawing resulted in severe surface deterioration of the nonair-entrained concrete.

Both faces of the dam were repaired in 1957. Large areas of concrete were removed and replaced with preplaced aggregate concrete. In addition, vertical holes were drilled through the dam into the foundation and injected with



chemical grout in an attempt to seal the voids and cracks. In 1972, cracks were grouted from the downstream face to further reduce leakage.

Numerous hydrologic and stability studies have been conducted on the dam since 1978 with the final conclusion being that the dam was structurally sound and strengthening was not required. However, it was decided to rehabilitate the dam to preserve the structure and prevent further deterioration and subsequent structural problems. This case history is a summary of a report on the project by Hutton (1989).

An engineering evaluation indicated that the depth of measurable frost damage caused by weathering ranged from 76 to 152 mm (3 to 6 in.) and that the interior concrete was comparatively uniform and of good quality; therefore, the primary rehabilitation objective was to stop the deterioration on the downstream face of the dam.

Five rehabilitation alternatives were considered: (a) waterproofing the upstream face and resurfacing the downstream face, (b) placing an RCC gravity section against the downstream face, (c) placing a rock-fill embankment against the downstream face, (d) replacing the dam with a new dam, and (e) placing a rock-fill embankment against the upstream face. These alternatives were evaluated in terms of the overall effectiveness, the geometric constraints of the terrain, the availability and quality of construction materials, the time and cost of construction, construction access, and potential environmental impacts.

The first alternative was considered to be the best approach because it was the least expensive and would preserve the aesthetics of the original arch dam. Also, the work could be done during the winter, so summer recreational activities would not be interrupted, and conventional concrete construction methods could be used.

Rehabilitation was started in October 1988 and proceeded throughout the winter, often under extremely harsh weather conditions. Temperatures dipped as low as  $-5^{\circ}\text{C}$  ( $-40^{\circ}\text{F}$ ) at night, and snow depths reached 1.5 m (5 ft).

The major problems encountered during construction were draining the reservoir, controlling sediment, and controlling concrete placement. When the reservoir was lowered, 6 to 7.6 m (20 to 25 ft) of sediment was found in the gorge immediately upstream of the dam. The outlet works intake structure was completely covered with sediment on three sides with only the top open. To control sediment during reservoir draining, workers (a) excavated and lined a diversion channel around the edge of the lake, (b) constructed an earth cofferdam about 107 m (350 ft) upstream of the arch dam and installed outlet pipes at different elevations in the earth dam, and (c) constructed straw overflow dams about 122 m (400 ft) downstream of the arch dam.

After the reservoir was drained, it was discovered that a considerable amount of aggregate was exposed on the upstream face of the dam on both the original concrete and the preplaced aggregate patches. The proposed cementitious

waterproofing material was designed to react with unhydrated lime in the cement and form a crystalline structure at and immediately below the concrete surface. This reaction cannot develop on an exposed aggregate surface. In addition, the petrographic examination of samples from the original concrete revealed that there was no unhydrated lime in the cement. Also, at each lift line, there existed a 152- to 203-mm- (6- to 8-in.-) wide band of badly deteriorated cement slurry of unknown depth. This band would need to be removed and replaced before the waterproofing was applied. In view of these findings, plans for rehabilitation of the upstream face of the dam were abandoned.

The downstream face of the dam was resurfaced with reinforced concrete. Deteriorated concrete was removed, and dowels (19-mm- (3/4-in.-) diam) were installed at 0.6 m (2 ft) on centers. The new concrete overlay has a minimum thickness of 203 mm (8 in.) and is reinforced with 19-mm (3/4-in.) bars spaced 381 mm (15 in.) on centers in each direction. The control of form work on the face of the dam was a problem because of the irregular nature of the existing concrete, the curved surfaces of the dam and spillway, and the contractor's electing to use prefabricated forms instead of custom-made forms, would have been cost prohibitive because of the additional time and cost involved. To maintain the curvature of the downstream face of the dam, the contractor had wooden templates fabricated to the required radius at the elevation of placement and used these as a guide for setting the forms.

The repair design required the installation of split PVC pipe drains over lift lines, cracks, and vertical contraction joints to collect seepage and prevent buildup of hydrostatic pressure behind the new concrete overlay. Difficulty was encountered in placing the rigid pipe against the rough concrete surface and sealing the edges to prevent concrete grout from flowing into and plugging the drain. The method used by the contractor to solve this problem was to place a piece of polyethylene backup rod over the edge of the split PVC pipe and caulk the joint with sealant. This method was only moderately successful, and considerable time was spent cleaning clogged drains. The use of one of the new geomembranes might be a better application to provide drains between new and old concrete.

The repair work was completed in June 1989.

### **International Control Dam**

The International Control Dam is located about 1.5 km (5 miles) above Horseshoe Falls. The 623-m- (2,044-ft-) long dam blocks that part of the Niagara River that flows between Chippawa, Ontario, and Tower Island, New York. The 18-bay dam, completed in 1962 under joint ownership of the Power Authority of the State of New York and Ontario Hydro, was designed to control both the volume of water flowing over the falls and the water level immediately upstream. Raising the head assists in diverting water to the power plants. The head is raised by adjusting the heights of hydraulically operated steel gates, framed into concrete piers spaced 34.7 m (114 ft) on centers.

Extending approximately 3 m (10 ft) above the piers are posttensioned, "T"-shaped pier caps. Bearing seat haunches at the ends of the 12-m- (39-ft-) wide caps support six 21.6-m- (71-ft-) long precast, prestressed arched I-beams that frame each bay. The beams are seated on phosphorous-bronze surfaced steel bearing plates and support a 7.3-m- (24-ft-) wide by 152-mm- (6-in.-) thick prestressed roadway deck slab, surfaced with asphalt.

Expansion joints located in the deck slab over the beam/pier cap interfaces were originally filled with a rubberized tar-based mastic material. As this material deteriorated over time, water penetrated the joints, carrying with it deicing salts that had been placed on the roadway during winter. Since most of the pier caps do not contain air-entrained concrete, cycles of freezing and thawing caused the concrete to deteriorate, which, in turn, led to corrosion of the steel reinforcing. Concrete in the protected beams and deck slab did not deteriorate.

A restoration program was begun in 1984 and extended into the early 1990's. Two or three bays were repaired each year, one at a time. Hubler (1984) described the repair process. His report is summarized in this case study.

A portable, steel-framed, concrete-block counter-weighted cofferdam was used to dewater the area under the span and provide adequate access to the pier caps. The 372-Mg (410-ton) beam and deck slab assembly overlying each bay was lifted with a hydraulic lift-climbing jack assembled to a Bailey Bridge structure. The Bailey structure acted as an overhead crane.

Before dewatering and Bailey assembly, asphalt was removed from the piers for the Bailey bearing locations and where the roller guide channel used to move the Bailey from one span to the next would be installed. The transflex expansion joint and rubberized tar filler in the joint between the pier and span were removed. A conventional waterblaster was used to remove the rubberized tar. Cores were diamond drilled for the support beam lifting cable, the lifting jack rods, and to free the steel conduits that cross the sawtooth expansion joint between the pier and span. The curb and handrail were removed to accommodate the Bailey structure.

The components for the Bailey bridge structures were assembled offsite and delivered to the dam site in segments as required. Portable, steel-framed, concrete-block counter-weighted cofferdams were installed upstream and downstream of the designated span, and the area was then dewatered. Fine to coarse cinders were placed against the gates to seal them.

Two steel lifting beams were lowered to the invert of the dewatered span and situated on top of steel pipe rollers. The lifting beams were then positioned under each end of the span, and three lift point locations were prepared at each end. The center lift point was used for the crane cable; the end lift points served as lift guides. The Bailey bearing pads were placed precisely at accurate locations. Steel batterboard offsets were used to mark the sides of the span, locating the line and grade. Twelve hydraulic lift climbing jacks lifted the span

3 m (10 ft) from its bearing location. The batterboard system was monitored during the lift so that tilt corrections could be made as needed. Bearing seat location was recorded as an average of three values from a string line positioned transversely from the offsets to the bronze bearing seat top.

Deteriorated material from the heavily reinforced concrete bearing seat was removed with a pneumatic chipping gun. The remaining concrete surface and exposed reinforcement was cleaned with a waterblaster. The formwork was prefitted to the areas being repaired and then removed prior to the application of the epoxy bonding agent. Cappar Nicklepoxy No. 19 Fresh Concrete Bonder was specified for the project. It was sprayed onto all exposed surfaces of the concrete and reinforcing with an airless piston-activated spray gun.

The new concrete in the pier caps was placed when the temperature of the old concrete was about 20 °C (68 °F). Placement at this temperature allowed between 60 and 90 min for the epoxy to become tacky enough for concrete placement. Following the epoxy application, the forms were reinstalled, and the super-plasticized concrete pumped into them. Aggregate size in the 34.5-MPa (5,000-psi) concrete was kept to 12.7 mm ( 1/2 in.) because of the heavy concentration of reinforcing steel. During the concrete finishing operation, a slight slope was left on the bearing seat to ensure that water does not “pond.” A “drip groove” was installed to prevent water and salt from migrating along the underside of the parabolic hammerhead pier.

Elastomeric bearing pads were placed on the underside of span bearing seats with an epoxy bonding material. When the new concrete had cured adequately, the span was lowered onto the piers in approximately 8 hr.

## **Kamburu Dam**

Kamburu Dam is located on the Tana River 160 km (99 miles) northeast of Nairobi, Kenya. The 56-m- (184-ft-) high asphaltic concrete-faced rockfill dam was built between 1970 and 1974 by Engineering and Power Development Consultants, Ltd., as part of a hydroelectric scheme that provides 18 percent of Kenya's installed power. The spillway structure is set in a rock cut channel 30 m (98 ft) deep and 50 m (164 ft) wide. The structure consists of a massive concrete rollway supporting four concrete piers. Between the piers are three 13-m- (43-ft-) square radial gates whose trunnion bearings are secured by prestressed tendons embedded horizontally within each pier. The structure is flanked by two stoplog stores (Figure 130).

In 1982, eight years after the construction of the spillway, relative movement was observed between Pier 1 and the adjacent stoplog store. This movement was monitored for 3 years until, in 1985, it was found that Pier 1 had deformed into the gate opening to such an extent that gate operation was impossible. An investigation at that time revealed cracks in the concrete on Pier 1 and water seepage through horizontal cracks 20-30 mm wide that were parallel to and adjacent to the tendons securing the gate trunnion. The cracking pattern within

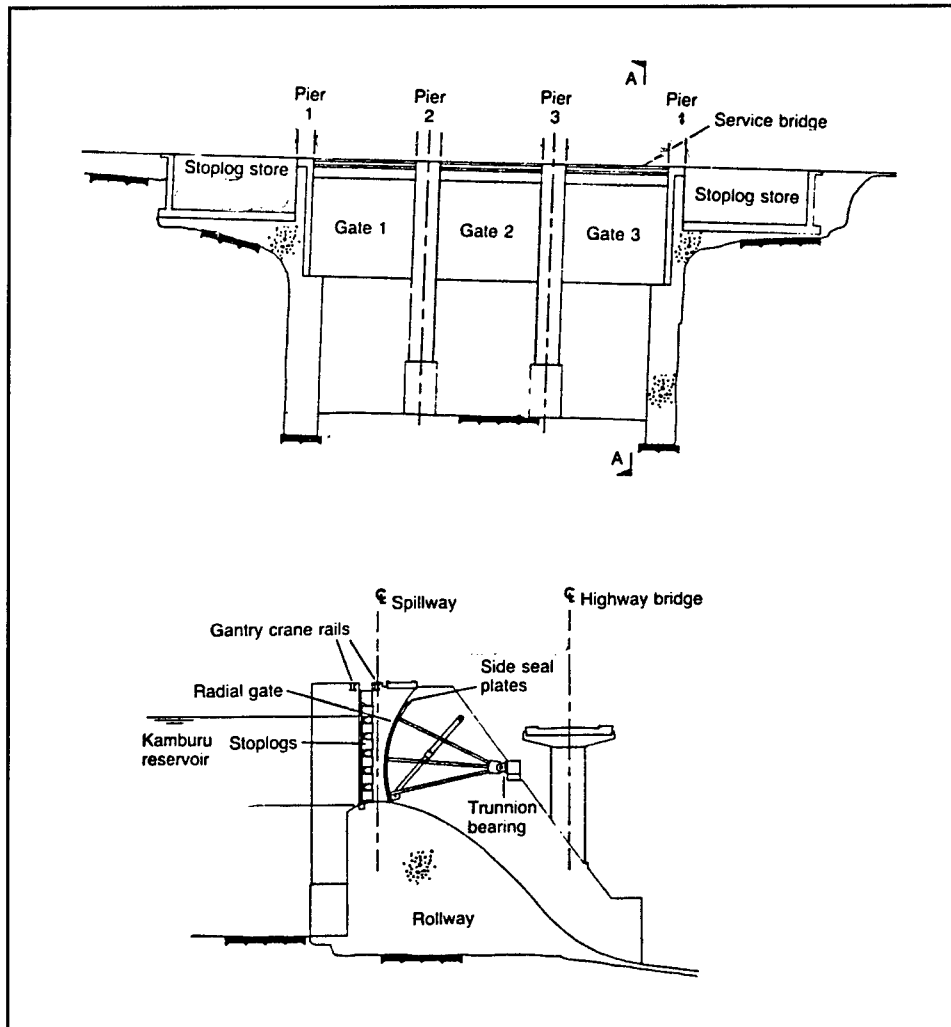

Figure 130. Upstream elevation and typical section of Kamburu Dam Spillway (from Sims and Evans 1988)

the left stoplog store confirmed the that the store was tilting. A study attributed the cracking to drying shrinkage, plastic shrinkage, plastic settlement, and alkali-silica reaction (ASR). This case history is a summary of a report by Sims and Evans (1988).

The distribution of ASR was patchy and concentrated in individual pours. The areas worst affected by ASR appeared to be those with greatest exposure to water from the abutments and on the highway bridge hammerheads where rain-water drained down. This finding is consistent with observations on other dams and ancillary structures affected by ASR.

Most of the cracking and consequent damage to the spillway was found to be caused by opal particles within the coarse aggregate. From a visual examination of the cores, it was estimated that 0.1 percent of the coarse aggregate particles were opal, but the distribution was randomly variable and about 35 percent of

the concrete contained little or no opal. In spite of the ASR, the concrete in the spillway was found to be good quality concrete.

An additional factor affecting structural behavior observed on Piers 1 and 4 appeared to have been loading from unstable rock wedges within the abutments. Pier 1 was analyzed to determine the size of the force needed to produce the distortion observed. This force was found to be an order of magnitude greater than the weights of the potential rock wedges within the abutments; therefore, the wedges by themselves could not have caused the observed distortion.

ASR thrives in an environment with a plentiful supply of moisture and, in time, can weaken the concrete. Additionally, rock wedges bear on the rear faces of the abutment piers. Therefore, the principal aims of the remedial works were to enable all three radial gates to function as designed, to reduce the intensity of the ASR by reducing the water available to the concrete, to relieve Piers 1 and 4 as far as possible of structural load from rock wedges, and to quantify, absolutely, future movement of the structure by installing comprehensive instrumentation; in this way the response of the spillway structure to the remedial works may be understood and the role played by each contributing factor quantified. This information will provide early warning for any necessary additional measures.

Gate 1 was released by trimming 140 mm (5.5 in.) off the side of the gate adjacent to Pier 1. Figure 131 shows the revised arrangement for the seal and also the new stainless steel sealing face. After the gate was released, the alignment of the gate arms and trunnion bearings were checked, and minor adjustments had to be made to relieve stresses induced by the misalignment of the gate and piers.

The measure taken to reduce the water available to the concrete included the following. The existing grout curtain under the stoplog stores was reinforced by placement of both a low-alkali cement grout and resorcinol-formaldehyde resin grout (Figure 132). Immediately under the stoplog store, a combination of curtain grouting and rib grouting was used, the curtain grouting being straight down to the spillway foundation level and the rib grouting inclined at about 1 radian (60 deg) to the vertical to intersect with the rear face of the pier. Both the curtain and rib grouting were carried out in three rows. The two outer rows were grouted first with cement grout. The central row was grouted later, first with cement and subsequently with chemical grout. This grouting reduced the overall permeability of the abutment rock. Additional protection to Piers 1 and 4 was provided by a further curtain of cement grout followed by chemical grout between each pier and the abutment rock.

The potential for water to seep into the upstream concrete face of the stoplog stores was reduced by coating them with a bituminous emulsion. The joint between Pier 1 and the stoplog store and the joint below the stoplog store both opened as a result of the rotation of the store. A flexible surface water bar was installed over these joints to inhibit water ingress, and the treatment was repeated on the right abutment. Similarly, the joints in the surface of the

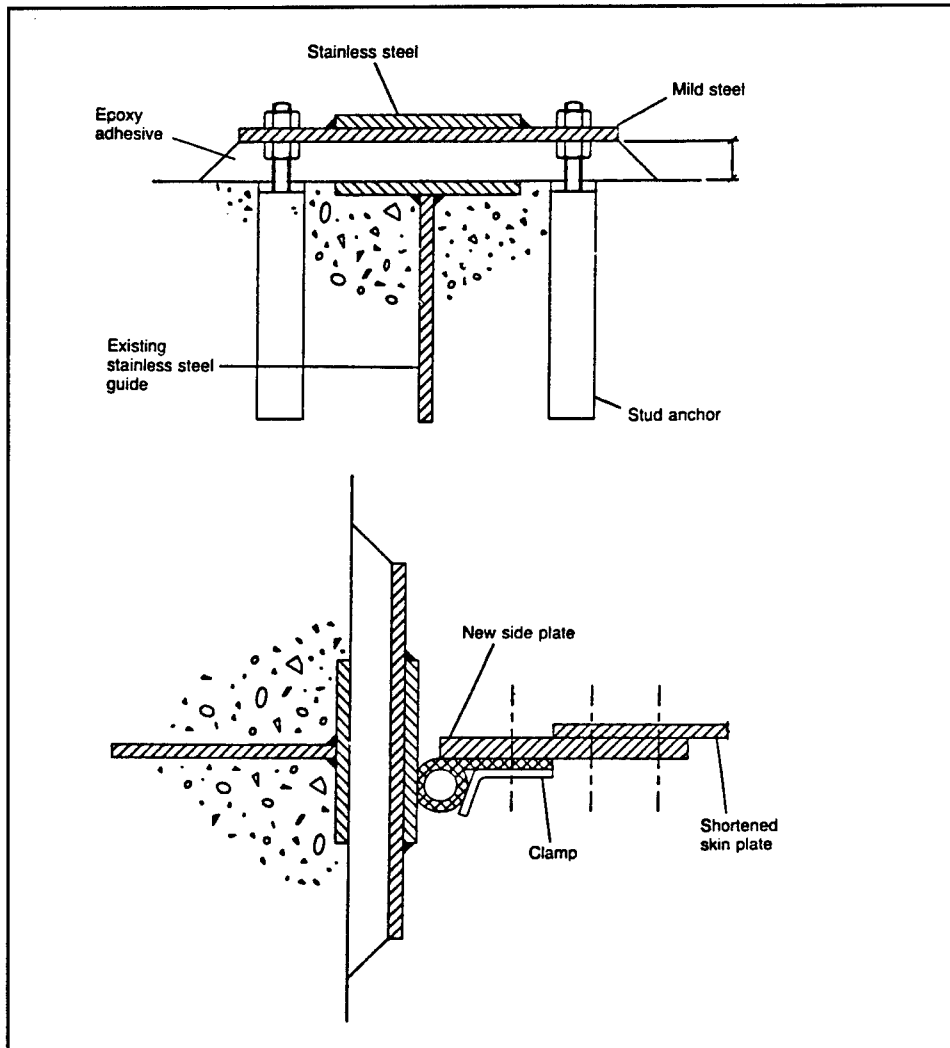

Figure 131. Modifications to radial gate, embedded parts and skin plate, at Kamburu Dam Spillway (from Sims and Evans 1988)

highway bridge were sealed with steel plates. In addition, water deflectors were incorporated at the tops of the bridge piers.

After the grouting was completed, drains were drilled into the abutment to remove water from the area downstream of the grout curtain. These drains consisted of 5-m- (16.5-ft-) long, 100-mm- (4-in.-) diam holes lined with perforated plastic pipe. The plastic pipes were extended beyond the face of the pier to allow the drainage water to be thrown clear. All remaining surface water from seepage or rainfall was diverted into purpose-formed gullies and pipes to discharge into a convenient point in the spillway.

Rock anchors were installed into abutment rock mainly through Piers 1 and 4. Fifteen anchors, 30 to 38 m (98 to 125 ft) long, were used on the left abutment

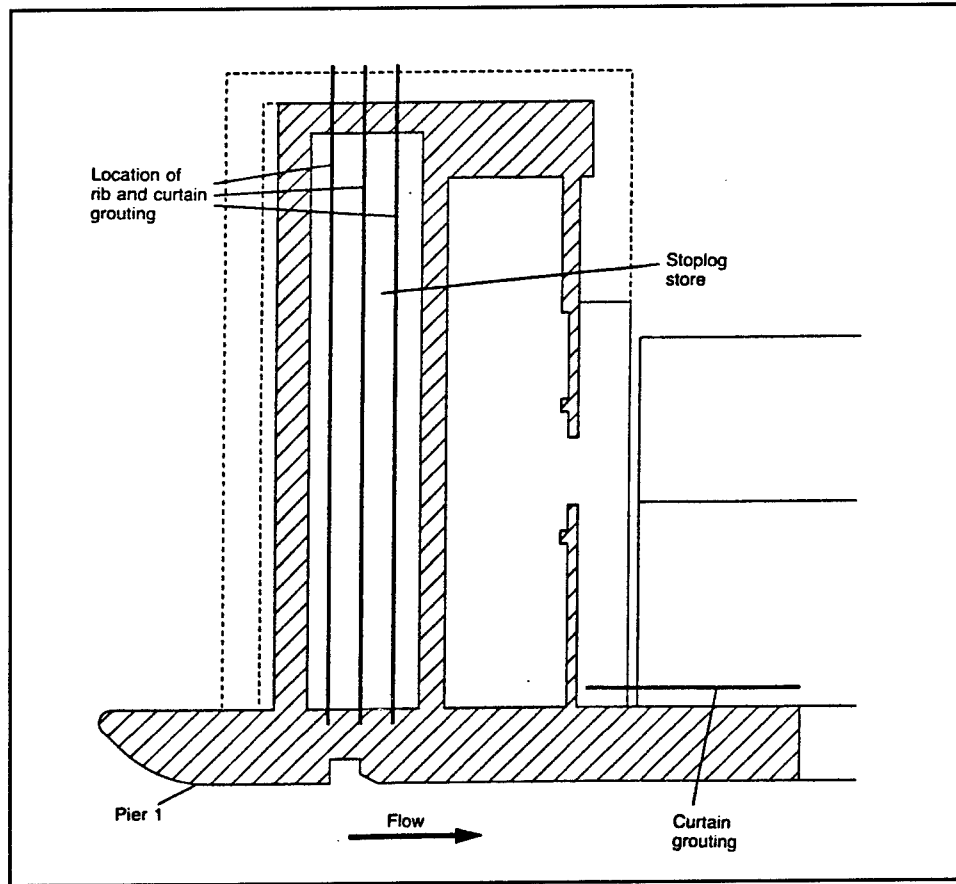

Figure 132. Grout locations on Pier 1 of the spillway at Kamburu Dam (from Sims and Evans 1988)

and an additional nine on the right abutment. These anchors were each of 1,470-kN (165-ton) capacity but were stressed to only 590 kN (66 tons). The extra capacity allows for adjustment should movement of the rock or pier require it. The anchor heads were set into the concrete of the piers and fitted with a sealing plate flush with the pier faces.

The larger cracks in the faces of the piers, notably at the bottom of the prestressed anchor zone, were sealed by injection of an epoxy resin after loose or deteriorated concrete was removed. It was considered prudent to leave smaller cracks untreated to allow moisture to pass out of the concrete piers.

A management strategy involving precise measurements is now in place for the spillway. The overall dimensions and relative positions of the spillway piers and abutments are measured by precise survey and by tape extensometer. Local movements are measured with borehole extensometers. Deflection of the piers from vertical and movement of the abutments are detected by inclinometers. Standpipe and vibrating wire piezometers monitor water pressures in the abutments, and seepage through the rock is measured at strategically placed V-notch weirs. The data obtained from the instruments will provide useful information on structural behavior of the spillway.



## Lost Creek Dam

Lost Creek Dam is located 112 m (70 miles) north of Sacramento, CA. The dam, which was completed in 1964, is owned and operated by Oroville-Wyandotte Irrigation District. The concrete arch structure is 37.2 m (122 ft) high and impounds a 6,969,275-cu m (5,650-acre-foot) reservoir that provides water for hydroelectric generation, domestic consumption, and irrigation.

In the mid-1960s, the porous concrete on the downstream face of the dam began spalling and cracking. Water seepage through the dam exacerbated the effects of cycles of freezing and thawing on the exposed concrete. In 1995, Oroville-Wyandotte Irrigation District began a study of available options for performing a long-term rehabilitation of the dam. Options evaluated included installing either a drainage layer protected with shotcrete or a roller-compacted concrete buttress at the downstream face. After careful study, installation of a CARPI USA geomembrane system on the upstream face of the dam to prevent water from seeping into the concrete was selected. This method would not require major structural rehabilitation; however, this would be the first underwater installation of a geomembrane on the entire upstream face of a dam.

The procedure for selecting materials and for installing the geomembrane was based on a study conducted under the auspices of the USACE. A review of the use of geomembranes as a means for controlling leakage in dams, conducted by McDonald (1993), revealed that the technique had been highly effective over the past 25 to 30 years; however, the installations had been done in the dry. Since dewatering is intrusive and costly, the next step in research was to develop a method for installing geomembranes underwater. The contract to develop an underwater geomembrane repair system was awarded in 1994 to CAPRI USA and Oceaneering International on the basis of their expertise in geomembrane systems and underwater construction and repair, respectively.

The study was conducted in two phases (McDonald 1998): the first phase consisted of researching and testing materials and developing an installation procedure; the second phase was a demonstration of the constructibility of the geomembrane system underwater.

Material recommendations based on project research were as follows: for the membrane, PVC with geotextile backing; for the drainage layer, high-density polyethylene (HDPE); for anchor bolts, stainless steel wedge bolts; for anchoring profiles, stainless steel flat bars; for gaskets, high-tack butyl-based sealant. It was also recommended that, if needed, a two-part epoxy resin be applied to smooth the surface concrete. The conceptual design of a typical geomembrane installation is shown in Figure 133.

In the demonstration phase, for which there was a hydrostatic head of about 6 m (20 ft) of water, five anchor bolts failed during one of the underwater installations. Suction was reapplied, and divers, using dye, were able to locate the small leak. The defective bolts were replaced underwater, and the system

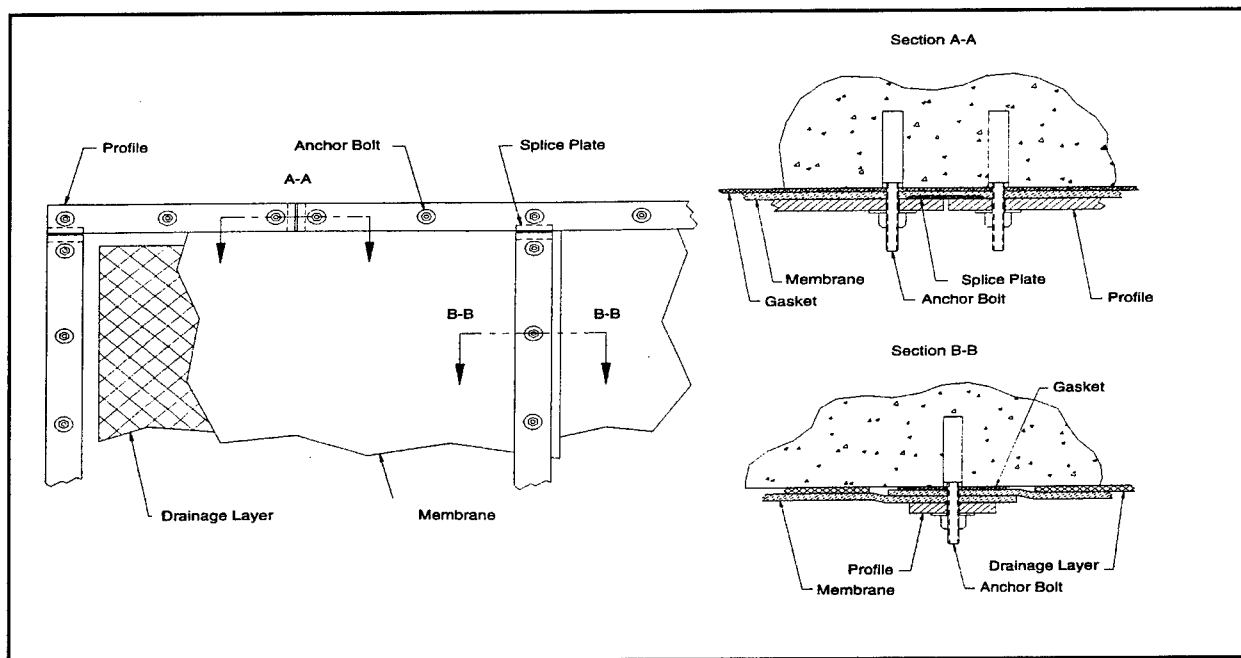

Figure 133. Conceptual design for a typical geomembrane system installation (from McDonald 1998)

remained conformed to the wall for the remaining 2 weeks of the test period. This situation proved that the geomembrane system could not only be installed underwater, but also could be repaired underwater (McDonald 1998)

The installation of the geomembrane at Lost Creek Dam was reported by Oneken (1998). This case history is a summary of his report. Prior to beginning the installation procedure, workers examined the upstream face of the dam and removed protrusions with grinders, filled underwater cavities with an epoxy or quick-set cement, and patched above-water cavities with PVC membrane or a thick geotextile.

The first step in the installation of the geomembrane was to install the above-water, perimeter anchors that would be used to seal the geomembrane to the dam's face. The 6.4-mm (1/4-in.) stainless steel dowells were anchored in the drill holes with an epoxy. Next, a 2-m- (6.6-ft.-) wide, 7-mm- (0.3-in.-) thick HDPE geonet was fastened to the dam in a cross-diagonal grid pattern, with 6.4-mm (1/4-in.) plastic impact anchors and stainless steel washers. The geonet was placed in this pattern so seepage behind the membrane would drain toward the lowest point of the dam (Figure 134).

Two-part vertical profiles, stainless steel frames, were installed above water on the geonet (Figure 135). The first, or internal, section of the vertical profile was anchored to the dam face with threaded, stainless steel anchor rods and chemical epoxy; the geomembrane was attached to this frame, and then the exterior vertical profile was bolted to the internal profile, tensioning the geomembrane.



Figure 134. Geonet installed on dam face with plastic impact anchors prior to installation of geomembrane at Lost Creek

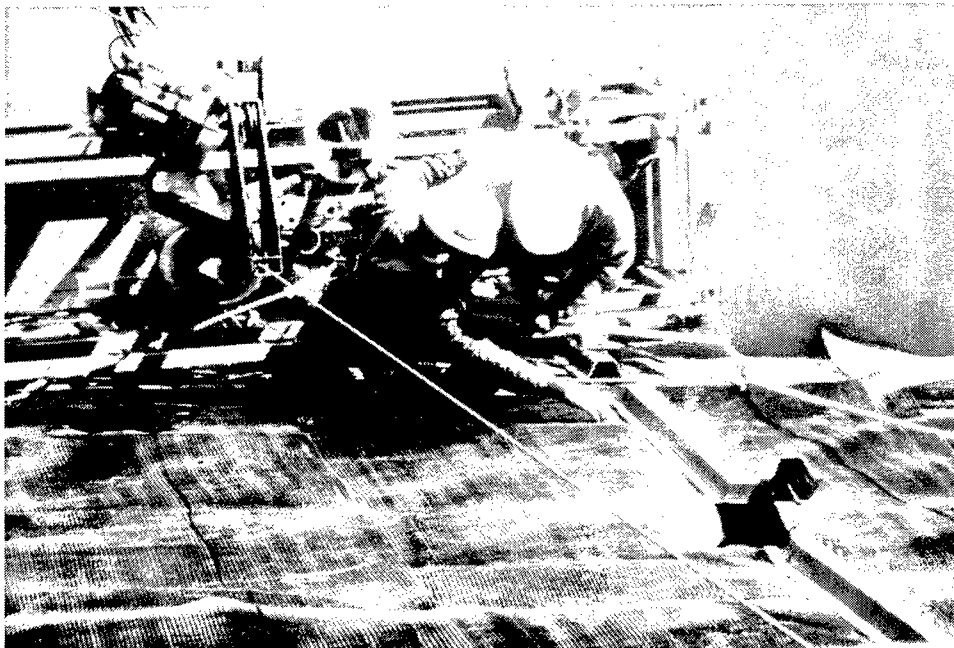

Figure 135. Workers anchor internal vertical profiles over geonet at Lost Creek Dam in preparation for installation of a geomembrane (from Onken 1998)

To install internal profiles underwater, divers worked from swing platforms that were controlled from a materials barge. They used grid lines as guides to ensure the internal profiles were installed in a perfect vertical line. Gasket material was placed on the installed vertical profiles to provide a watertight seal at the membrane joints. The geomembrane was installed next. Using a crane, workers lifted the top end of each of the 16 panels until it was level with the upper perimeter seal, pulled it to the dam face, and then unrolled the remainder of the panel onto the materials barge and into the water. Divers aligned the panels with the installed internal vertical profiles, making sure the panels overlapped sufficiently (Figure 136). The installation team on the bridge deck used chain falls and winches to make adjustments according to instructions from the divers. Once the panels were aligned, divers secured them to the dam face above the perimeter seal. Another layer of gasket material was placed over the geomembrane, and the external vertical profiles were clamped to the internal vertical profiles, creating tension between the two profiles and pulling the panels toward the face of the dam.

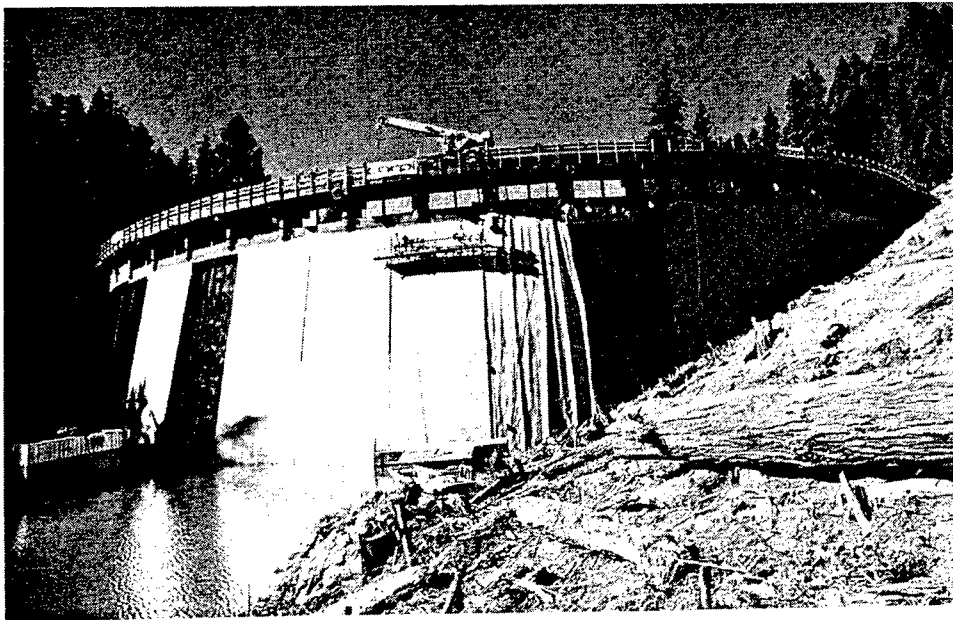

Figure 136. Workers on swing stages install 16 precut geomembrane panels on the upstream face of Lost Creek Dam (from Onken 1998)

PVC cover strips were welded over the external profiles to create a watertight seam. Three 51-mm- (2-in.-) diam ventilation holes were drilled behind the internal profiles through the dam at the panel joints to prevent a vacuum from developing behind the membrane. Also, a 102-mm- (4-in.-) diam core hole was drilled at the lowest point of the geomembrane to provide drainage for seepage and dehydration water. Divers placed a seal over the core hole on the reservoir side; then they placed a 76-mm- (3-in.-) diam stainless steel pipe into the hole and grouted it in place. When the grout set, they installed a ball valve on the downstream end of the pipe. The seal was removed, and a drainage accumulator plate was anchored to the dam just above the exit hole.

A piezometer conduit was anchored to the face of the dam to enable workers to monitor water accumulation in the geonet drainage layer. A water level indicator allows workers to measure water levels from the bridge deck.

Continuous monitoring of the water level indicator since the geomembrane installation was completed indicates there has been no water accumulation in the drainage layer between the geomembrane and the dam on the upstream face. The latest reported measurement of the flow of water behind the membrane, which was taken 30 March 1998, shows the flow to be 0.47 ℓ (0.125 g) per minute.

Total cost of the project, which includes consultation fees, Oroville-Wyandotte's staff's time, all preparation activities, and the actual installation, was \$2.6 million. Costs for other options evaluated ranged from \$3 to \$6 million.

### **Mactaquac Dam**

Mataquac Generating Station, which is owned by New Brunswick Power (Figure 137), is located on the Saint John River 20 km (12.5 miles) upstream of Fredericton, New Brunswick. The project consists of a concrete rock-fill dam, powerhouse, intake, and spillway. The Mactaquac Generating Station has an installed capacity of six 653-MW units.

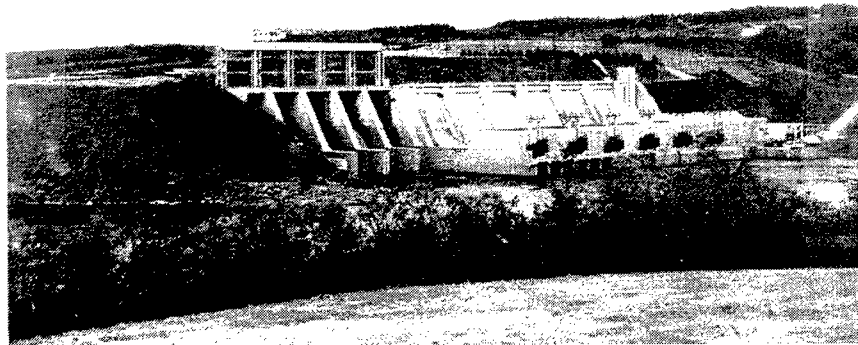

Figure 137. Mactaquac Dam

From the time the dam was constructed in the late 1960s, it had been slowly but steadily expanding. As a result, by 1988, a spillway structure pier had moved 30 mm (1-1/4 in.) off-line, there had been some gate obstruction and some cracking in the powerhouse generator floor. The expansion of the concrete

was attributed to alkali-aggregate reaction. In the original construction of the dam, a greywacke aggregate was used with cement containing alkali.

New Brunswick Power began a program for data monitoring and remedial work that included a \$330,000 contract for making two vertical cuts in the concrete cross section of the dam between Units 5 and 6 in the spillway/intake to take pressure off the adjoining spillway structure pier and help bring it back in line. Biefer (1989) described the cutting; this case history is a summary of his report.

The contract for the cuts was awarded to Trentec, one of two firms invited to bid on the job. Trentec uses a specially modified diamond wire saw that is continuously moving avoids being trapped in the cut concrete by staying ahead of the cut. The saw has a drive unit with a large diameter drive wheel that is hydraulically powered, idler wheels, and a diamond-plated cutting wire.

Before the cutting could begin, the work area had to be dewatered. A separate contract was let for construction of a blister cofferdam to be placed in front of an intake structure on the upstream face. The cofferdam was constructed of a 2.74-m- (9-ft-) diam by 23-m- (75-ft-) long half-circle of concrete pipe. The vertical cofferdam provided a dry access path for the cutting crew and upstream cut line. The intake gates for Units 5 and 6 were closed and the intake dewatered.

The next step was to provide reinforcing for the intake structure and piers in case any major cracking occurred as heavy stress loads in the structure were relieved. Reinforcing steel was placed on the walls inside the intake structure adjacent to the cut area and 57 stressed steel tendons were also positioned inside the intake structure.

With reinforcement in place, workers drilled five holes from the downstream face to the upstream face of the dam, following the vertical path of the intended cut. The bottom cut was made first. The drive unit was placed on the ground in front of the dam. The cutting wire was run through the second lowest hole on the downstream face to idler gears on the other side of the structure, and then threaded back through the lowest hole to the drive unit to form a continuous loop. The cut was made through the concrete down to the bottom of the dam, ending up with a 10-mm (0.4-in.) vertical slot covering a 280-sq m-(335-sq yd-) cross-sectional area of the concrete wall.

As the first cut closed behind the wire saw, the 'load' or pressure caused by the growth was transferred to the top half of the dam. Trentec's crew then moved their equipment to the very top of the dam (Figure 138) to begin the second vertical cut. The 10-mm- (3/8-in.-)wide cut began to close when the diamond wire saw was about 6 m (20 ft) from the top. The second vertical cut intersected the slot of the first cut, completing the project. The second cut relieved pressure on the top half of the dam.

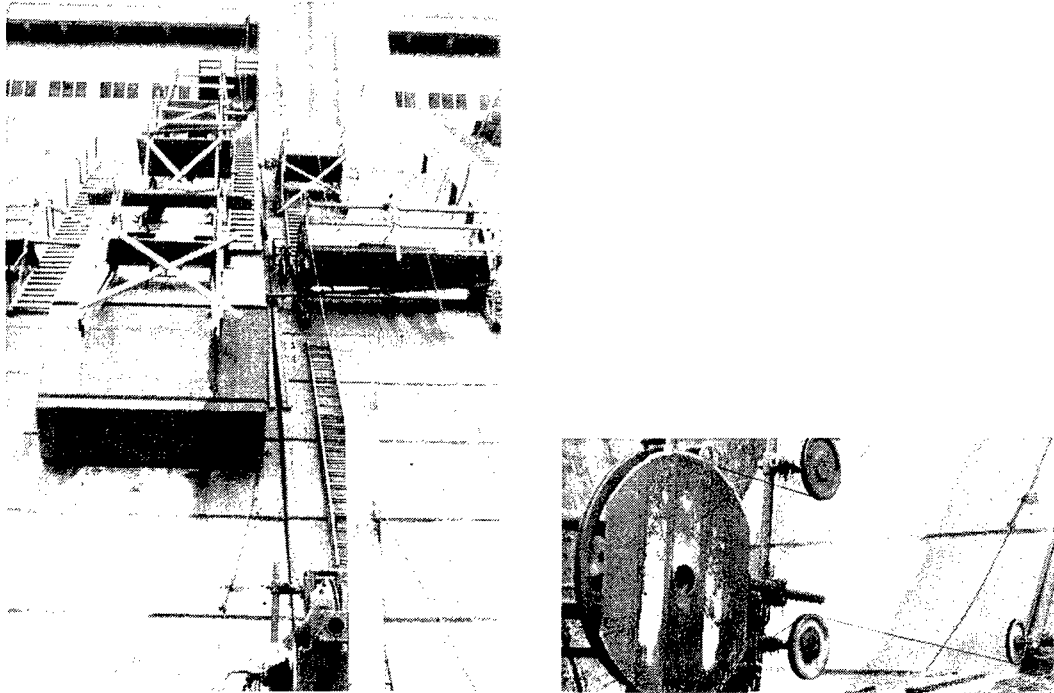

Figure 138. Diamond wire cutting of Mactaquac Dam

Crews worked around-the-clock for 13 full days to make the two cuts, which covered a 483-sq m- (578-sq yd) cross-sectional area of the concrete structure. The 10-mm (0.4-in.) cut closed almost completely, and any small gaps were grouted and sealed. The leaning spillway pier “rebounded” by about 6 mm (1/4 in.) as the dam moved in and about (5/32 in.) 4 mm on the other side of the cut. The cutting program had “shrunk” the growing dam section about 10 mm (0.4 in.), the exact width of the cuts. This amount was estimated to be the equivalent of 1 year’s growth at the spillway east end pier.

By 1989, three diamond wire saw cuts had been made at the intake section of the structure. Although the cuts were effective in reducing the problems of concrete expansion, they had a limited duration of effectiveness because of their small width, 10 mm (0.4 in.), and the continuing expansion of the concrete. In 1991, four methods of cutting were under consideration for future wider slots. These methods are listed in the following tabulation.

| Cutting Methods Under Consideration at Mactaquac ( <i>Water Power &amp; Dam Construction 1991b</i> ) |                 |  |
|--|-----------------|--|
| No. Method   | Lifetime        | Comments   |
| 1 12.7-mm- (0.5-in.-) diam diamond wire saw cut  | 4 years         | Proven method but frequent recuts.                               |
| 2 Larger diameter diamond wire saw cut   | 8 years perhaps | Needs development of wire saw but otherwise proven method.       |
| 3 102-mm- (4-in.-) wide parallel double wire saw cut   | 30 years        | Problem is removal of concrete slabs.                            |
| 4 Overlapping 102- or 152-mm- (4- or 6-in.-) drill holes   | 18 to 26 years  | Proven method, requires drill guides, concern regarding binding. |

In addition to the intake section, consideration was being given to diamond wire cuts in the powerhouse and the diversion sluiceway (after *Water Power & Dam Construction 1991b*).

### Morris Sheppard Dam

Morris Sheppard Dam is located on the Brazos River in Palo Pinto County, Texas, about 128 km (80 miles) west of Fort Worth. The 504-m-(1,655-ft-) long, 58-m- (190-ft-) high, flat-slab, buttress dam controls a drainage area of over 3,367 sq km (13,000 sq miles) that forms Possum Kingdom Reservoir, a 703,095,000-cu-m (570,000-acre-ft) lake. The service spillway for the dam (Figure 139) contains nine 22.3-m- (73-ft-) wide, 4-m- (13-ft-) high roof weir gates, which have a maximum discharge capacity of 14,200 cms (500,600 cfs). The dam, which was completed in 1941, is owned and operated by the Brazos River Authority (BRA). It provides hydroelectric power, recreation, and water supply for municipal, industrial, and irrigation uses.

The design of Morris Sheppard Dam utilizes the weight of the structure and impounded water to stabilize the dam against overturning and sliding. This concept was first employed for reinforced concrete buttress dams by Nils F. Ambursen at Theresa, NY, in 1903. The principal structural components of the buttress dam include reinforced concrete, flat-slab lake-wall panels and massive concrete buttresses. The massive buttresses are spaced on 12-m (40-ft) centers to form thick concrete walls. They have a triangular shape and are proportioned to transmit the water load and the weight of the structure to the foundation rock. The base of each buttress is integrally connected to a thick concrete spread footing designed to interface with the foundation rock to sustain the gravity and overturning loads of the dam. The lake-wall panels, which span between the buttresses, are supported at the buttresses on thickened corbels. These panels are keyed into the buttresses and thus transfer their water load and weight entirely to the buttresses. The lake-wall panel and buttress connections at the corbels are articulated to allow for temperature expansion and some vertical or horizontal



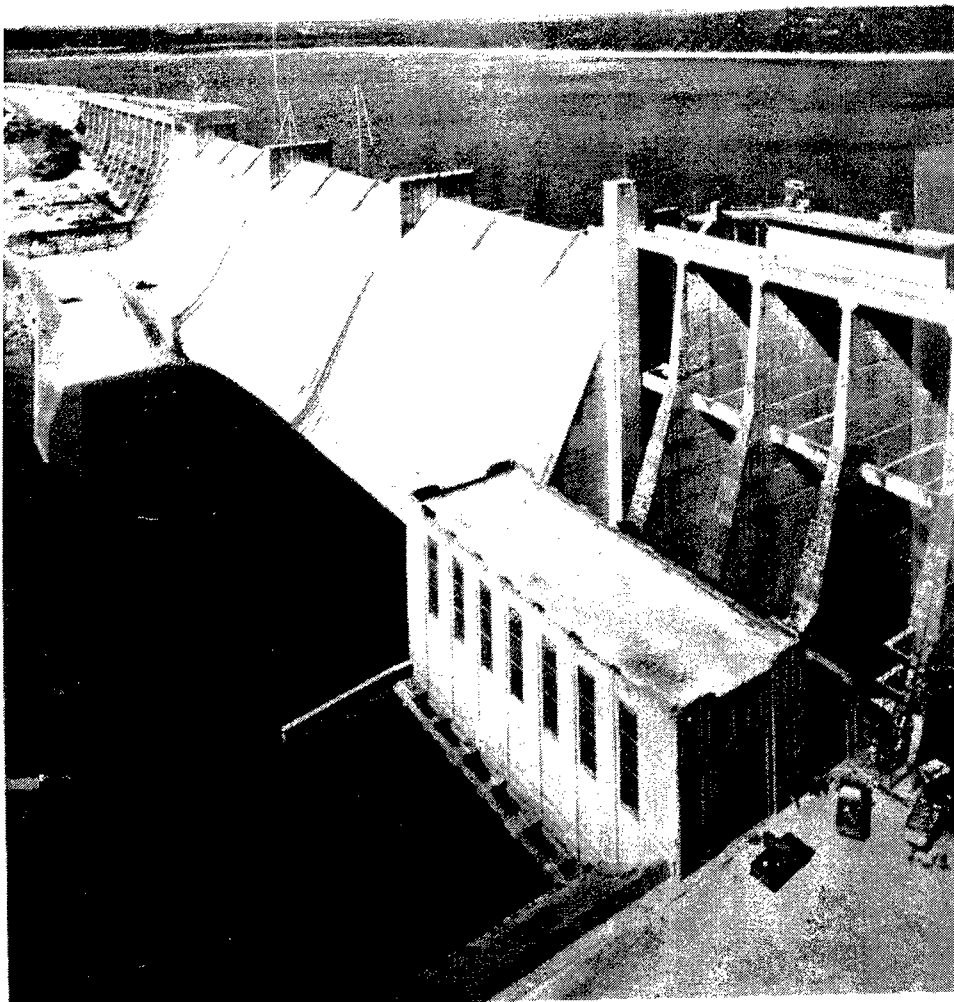

Figure 139. Downstream view, Morris Sheppard Dam (from *ENR* 1988)

displacement between buttresses without losing the water seal or inducing moments in the buttress corbels. The lake-wall panels tie into a transition beam that serves as a seating for these panels and a cap for the upstream toe wall (Thompson and Waters 1989).

The downstream side of the spillway buttresses is covered by reinforced concrete deck panels, similar in design to the lake-side panels. The concrete spillway uses a combination of raised and flat roller buckets with a hearth and deflector to dissipate the velocity head generated during spillway discharge.

The rock strata in the vicinity of the dam are composed of several thick beds of hard limestone, grading into the Wolf Mountain shale. The buttress footings were usually set on the blue shale, but along the south abutment, footings are on

the sandstone overlying the shale. To control seepage under the dam, a 10.7-m- (35-ft-) deep concrete toe wall was saw cut into the shale at the upstream toe of the dam. Weep holes and foundation drains for the buttress footing were also provided (Thompson and Waters 1989).

**Inspection results.** A 5-year inspection of the project was conducted in December of 1986. The inspection revealed movement of the service spillway buttresses downstream, shearing of the surface at the level of the upstream toe wall and a hydrostatic pressure equivalent to 65 percent of the lake head acting on the upstream toe wall, erosion along the south bank of the river downstream of the hearth, cracking in the hearth slabs downstream of buttresses 16 to 26 and structural cracking of the buttress corbels between buttresses 26 and 33, insufficient openings of the spillway buttresses between bays to prevent a rising high tailwater from creating a buoyancy condition that would adversely affect the stability of the dam during large floods, and nine gates in the service spillway capable of accommodating only 60 percent of the calculated present-day PMF. A recommendation based on these findings led to further investigation and the implementation of corrective actions (Thompson and Waters 1989).

In April of 1987, the BRA lowered the lake level from the normal pool elevation of 1,000 to el 987 to reduce the driving force acting on the dam (portions of the spillway had moved as much as 114 mm (4-½ in.) from its original alignment) and to provide an immediate increase in the stability of the dam. Concurrent with this lowering of the reservoir, the BRA initiated emergency construction and geotechnical contracts to access the spillway bays, extend the geotechnical investigation, and install relief wells across the service spillway (Thompson and Waters 1989).

**Construction and investigation.** The construction and geotechnical investigations proceeded concurrently. A footing level, 2.4-m- (8-ft-) diam, passageway was drilled through buttresses into the enclosed spillway bays. Once the passageway had been constructed, each bay was mucked out and filled with crushed gravel to form a working platform for relief well and instrumentation installation (Figure 140). As the working platform was constructed, additional instrumentation and piezometers were installed farther upstream in the spillway bays. In total, 132 piezometers, 10 inclinometers, and 18 extensometers were installed to monitor the piezometric pressure and movement of the dam (Thompson and Waters 1989).

The progression of the access passageway and the gravel working platform allowed the installation of a relief-well curtain across the upstream end of the bays forming the service spillway. The relief-well curtain was designed to consist of 152-mm- (6-in.-) diam relief wells spaced every 4 m (13 ft); however, as the wells were installed in the region of buttresses, 14 to 19 high-pressure flows of up to 1,893 lpm (500 gpm) were encountered, which necessitated installing additional wells in these bays. A total of 146 wells, some as large as 305 mm (12 in.) in diameter, were installed without effectively stabilizing the piezometric pressures (Thompson and Waters 1989).

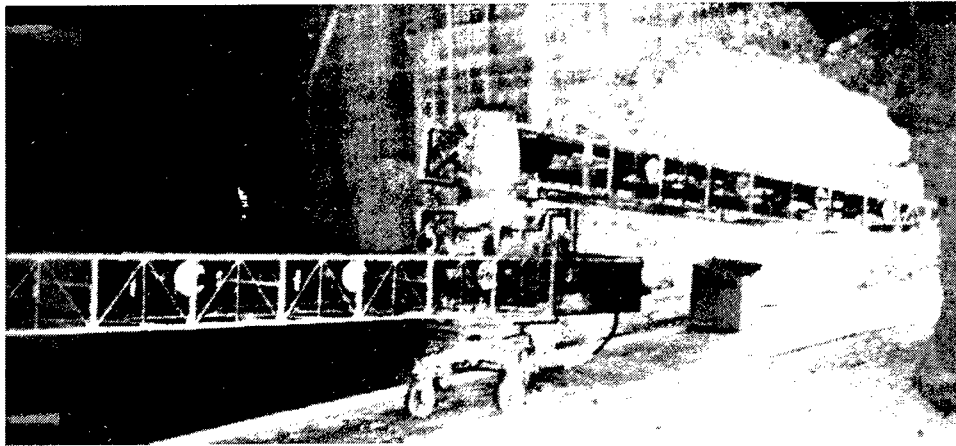

Figure 140. Muck being removed from bay at Morris Sheppard (from *ENR* 1988)

**Grouting.** A series of exploratory core holes were drilled into the upstream end of Bays 14 and 15 in an attempt to isolate the entry of the relief-well flows. These holes indicated that the flow was entering the foundation of the dam in the vicinity of buttress 14. These core holes also encountered a high-pressure flow and diagonal crack at the interface of the concrete transition beam and toe wall. After considering the various grouting techniques available for sealing this crack, the use of a sodium silicate grout accelerated by cement was selected, and a series of primary and secondary grout holes were installed. The typical set time for the primary grouting effort was approximately 1 min. Prior to the primary grouting effort, the total flow from the relief wells in Bays 14, 15, and 16 was on the order of 2,082  $\ell$ pm (550 gpm). After the primary grouting effort, these flows were reduced to 45  $\ell$ pm (12 gpm). The reduction in flow was accompanied by a corresponding reduction in the foundation piezometric pressures as measured by numerous piezometers. The secondary grouting effort further reduced the relief-well flow from 45 to 7.6  $\ell$ pm (12 to 2 gpm). In some of the secondary grout holes that exhibited low flows, neat cement was used to seal off the crack and flow zone. This combination of sodium silicate and neat cement grouting was very successful in sealing off the flow zone entering the foundation near buttress 14 and did not affect the existing relief-well curtain or the piezometers that were monitoring the foundation conditions (Thompson and Waters 1989).

The relief of the hydrostatic pressure encountered in the foundation of Morris Sheppard Dam was basically achieved over a 1-year time frame as a result of the installation of the 146 relief wells and selective grouting of the flow zones feeding the foundation joint system.

Throughout the investigation and improvement efforts, the buttresses were monitored to detect any movement. Extensometers installed in critical buttresses and conventional precision surveys of monuments at the top of the buttresses and along the catwalk through the spillway gates were employed. Readings show

that buttress 21 moved approximately 6.4 mm (1/4 in.) downward and upstream along the axis of the slanted extensometer. This movement is interpreted to be associated with the venting of the hydrostatic uplift and consolidation of the pressurized zones of the foundation shale. Conventional precision surveys of monuments established along the catwalk through the service spillway were also made prior to and after the venting of the hydrostatic pressure. These surveys confirm that the downstream dam movement previously noted has been completely arrested by these efforts (Thompson and Waters 1989).

**Emergency spillway.** The initial investigation showed that Morris Sheppard Dam did not have sufficient spillway capacity to pass the PMF without overtopping. As part of the project remediation, a decision was made to construct an emergency spillway to remedy this problem.

The top elevation of the concrete nonoverflow sections of the dam is 1,024. Structural analyses of the dam based on proposed rehabilitated conditions showed that flood levels that overflowed the top of the structure would cause undue stress on the upper flat slab panels; therefore, the emergency spillway needed to be designed to pass the entire PMF with a maximum lake elevation below el 1,024. This requirement eliminated any alternative that involved raising the top of the dam. At the same time, the capacity of the existing spillway would have to be nearly doubled (Rutledge 1989).

The site selected for the emergency spillway was the south abutment. The terrain in this area limited the width of the emergency spillway to 427 m (1,400 ft), because additional width would require rock excavations deeper than 21.3 m (70 ft), and benefits would not be proportional; for example, increasing the width of the spillway to 488 m (1,600 ft) would provide less than 0.3 m (1 ft) of protection but would require an additional 191,000 cu m (250,000 cu yd) of rock excavation. The 427-m (1,400-ft) width limit meant the crest of the emergency spillway must be set at the conservation pool level of 1,000, and a fuse plug would be required to prevent excess discharge from relatively frequent storms.

In the summer of 1988, a hydraulic model study was done at the Utah Water Research Laboratory to determine the actual discharge capacity rating curve for the existing service spillway, to investigate the operation of the spillway in conjunction with the proposed emergency spillway, and to develop methods for providing erosion protection downstream of the spillway. The hydraulic model was used to study two possible solutions. The first alternative was to construct a roller-compacted concrete stilling basin at el 870 about 8 m (25 ft) below the existing hearth. This lower basin, under most discharge conditions, would serve as a plunge pool for the jet flipped by the upper basin. However, the study indicated that under high discharge conditions, the high tailwater would force a hydraulic jump back into the upper stilling basin.

The second alternative consisted of a combination of emergency spillway configuration and operation of the service spillway gates to provide sufficient tailwater for all discharge levels. This alternative would eliminate the need for a

second stilling basin. The first step in the hydraulic model study was to establish a minimum tailwater condition that would be required to create a hydraulic jump condition on the hearth downstream of Gates 6 through 9, the southernmost four gates of the service spillway. The next step was to determine a combination of gate-release policy and sufficient emergency spillway discharges to provide the needed tailwater in the entire range of lake levels. A loop tailwater rating curve developed by Freese and Nichols in 1985 for a breach analysis of Morris Sheppard Dam was used to calculate associated discharges and tailwater levels.

Of primary concern was the amount of tailwater present during different overflow conditions. The spillway gates create the normal water level of el 1,000; any reservoir rise above this level would cause some discharge over all nine gates regardless of whether they were open or closed. For reservoir rises up to 1.5 m (5 ft), the deflector downstream of Gates 6 through 9 forces a hydraulic jump of the discharge that would flow over these gates in their closed position. If the amount of tailwater was not adequate to force a hydraulic jump to the hearth upstream of the deflector sill, discharges over Gates 7 through 9, in their closed position, would flip over the deflector sill and create a potential for significant erosion. To prevent such a condition from occurring, when the reservoir reaches el 1,006, Gate 6 is to be closed, and the entire emergency spillway operating. For this reason, a 1.5-m- (5-ft-) high fuse plug was designed for the entire 427-m- (1,400-ft-) wide emergency spillway. When the reservoir reached el 1,010, there would be adequate tailwater to allow Gates 7, 8, and 9 to be lowered.

The gate operation policy, based on findings from the hydraulic model study, was to (a) lower Gates 1 through 5 to maintain a reasonable lake level; (b) lower Gate 6 when the reservoir reaches el 1,005; and (c) lower Gates 7 through 9 when the reservoir reaches el 1,010. The fuse plug will begin to breach when the reservoir rises above el 1,005.

Also, according to the hydraulic model study, 1.2-m- (4-ft-) diam riprap placed for a distance of 30.5 m (100 ft) downstream of the hearth deflector would provide sufficient erosion protection downstream of the stilling basin below Gates 6 through 9. Twenty 0.3-m- (1-ft-) long anchor bars grouted into the existing rock in a 3-m (10-ft) grid pattern would provide stability for the riprap.

A total of 504,603 cu m (660,000 cu yd), mostly rock, was excavated in the south abutment of the dam for the emergency spillway. Converging boundaries downstream of the crest reduced the amount of excavation required. Areas where the final excavated surface was not rock were over-excavated to sound unweathered rock; soil cement was used to fill the over-excavation to grade. An estimated 16,820 cu m (22,000 cu yd) of soil cement would be required for the project. To prevent overflow of emergency spillway discharges from flowing back toward the base of the dam on the north side of the emergency spillway, crews constructed a 7.6-m- (25-ft-) high levee. Soil cement was placed on the channel-side slope to provide erosion protection.

**Fuse Plug.** The fuse plug had to be designed to remain stable under relatively frequent reservoir loadings of 0 to 1.5 m (5 ft) because its base is at the conservation pool level; it had to begin breaching when the reservoir rose above el 1,005 and to be completely eroded away when the reservoir reached el 1,006; it had to have sufficient wave erosion protection on the upstream slope; and because of its height, it could not have the usual numerous interior zones as they would widen the cross-sectional area of the fuse plug considerably, which would slow the erosion process. Specifications called for the filter cloth to be placed in sections 3.8 m (12-1/2 ft) wide or less so not to impede the erosion process. No bonding between panels was allowed, although panels could be overlapped. The top of the fuse plug was set at el 1,007; a pilot channel crest was set at the required el 1,005. Around each pilot channel, the clay core zone was extended downstream in a 305-mm (12-in.) layer to just below the pilot channel invert to prevent significant amounts of shallow discharges from flowing through the gravel fill below the pilot channel. Six central pilot channels were spaced across the 427-m (1,400-ft) length of the fuse plug, so the entire fuse plug would erode in approximately 30 min. This time limit was based on PMF calculations for providing sufficient tailwater for the rapidly rising lake level (Rutledge 1989).

With the recommended five gates operating, the spillway has a discharge capacity of 1,515 cms (53,500 cfs). When the reservoir reaches level of el 1,005, this amount increases to 2,741 cms (96,800 cfs), 97 percent of the estimated 100-year inflow. The emergency spillway with the 427-m- (1,400-ft-) long, 1.5-m- (5-ft-) high fuse plug enables the dam to pass the full PMF with a peak level of el 1,023.4, 178 mm (7 in.) below the top of the dam.

In 1990, a follow-on construction contract was let to add 66,590 cu m (87,000 cu yd) of lean concrete ballast to the spillway bays. With the completion of these contracts, the factor of safety of Morris Sheppard Dam was increased to 1.75 in compliance with the Federal Energy Regulatory Commission requirements. The total contract effort for the Morris Sheppard Dam improvements was in excess of \$30 million dollars (Thompson and Waters 1990).

## **Olmos Dam**

Olmos Dam is located on Olmos Creek, a tributary 8.8 km (5-1/2 miles) upstream of the central business district of San Antonio, TX. The dry reservoir dam was constructed to impound and control release of flood water when heavy rains fall in the area. The release of flood water is regulated through the flood gates of the dam until the reservoir is drained.

The Olmos Dam drainage area is subject to heavy rainfalls that result when unstable air moves from the Gulf of Mexico over southwest Texas. At times heavy rainfall covers more than 31,000 sq km (12,000 sq miles) in this area. Studies conducted in 1973 disclosed that a 100-year storm event, such as those in 1921 and 1972, would overtop the dam and overstress it beyond safe limits.

An additional study to determine the most cost-effective method for ensuring that Olmos Dam would be able to control high volumes of rainfall runoff was authorized in 1974 and completed in 1975. This case history is a summary of a report on modifications made to Olmos Dam in *Civil Engineering* (1982).

The first alternative considered was the placement of mass concrete on the entire downstream face of the dam. This option was rejected because of costs and the modifications to the existing stilling basin and sluice-way discharge at Olmos Creek that it would have required. The alternative selected was to strengthen the two nonoverflow sections with prestressed anchors installed in 2- to 3-m- (7- to 10-ft-) thick, hard limestone 15 m (50 ft) below the base of the dam (Figure 141) and to increase the stability of the spillway with mass concrete (Figure 142).

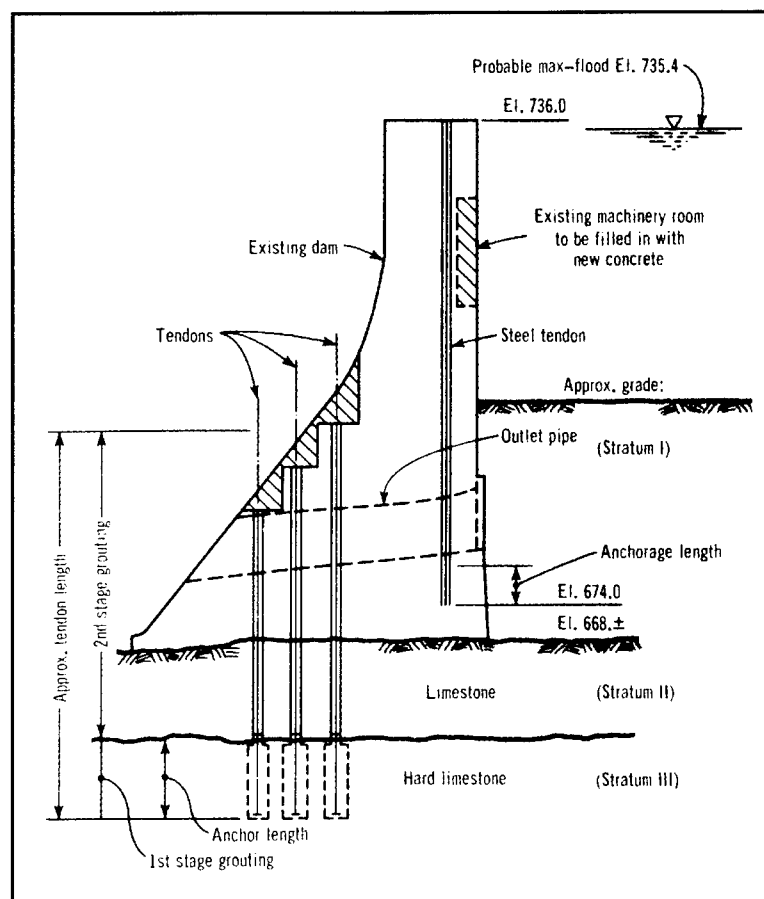

Figure 141. Placement of prestressed reinforcing to strengthen nonoverflow sections at Olmos Dam (from *Civil Engineering* 1982)

Before construction began, approval had to be obtained from property owners, adjacent municipalities, the San Antonio Fine Arts Commission, the Olmos Task Force Committee, the San Antonio Parks Department, and the Archeological Survey Unit of the Texas Department of Natural Resources.

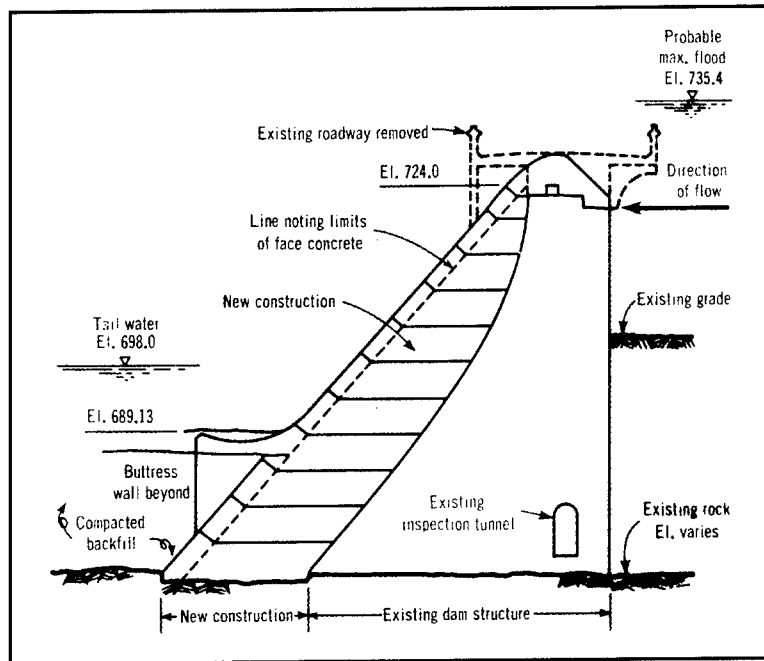

Figure 142. Spillway section strengthened with mass concrete at Olmos Dam (from *Civil Engineering* 1982)

Construction began in 1979 with the first project being the construction of a detour road, which specifications required to be open before Olmos Drive, located on top of the dam, was closed. Two problems that had to be overcome during construction were excessive groundwater in the limestone stratum at the contact plane for the dam and brecciated limestone rock in an area under the spillway. The brecciated limestone rock was grouted.

For construction of the 39-m- (1,287-ft-) long ogee spillway crest, the topmost portion of the dam had to be removed. For the first time ever, explosives were used to remove sections of an existing dam. High-velocity, small-charge explosives were detonated sequentially, creating a result similar to that of presplitting in quarrying. This technique reduced by half the amount of time that would have been required to remove the top sections of the dam. The shock produced by the explosives was less than what would have been produced by a hydraulic ram. Permission to use the explosives was obtained from the Antonio River Authority. The use of explosives helped bring in the low bid for the project within 2 percent of the estimate.

Additional modifications made at Olmos Dam included construction of a flip bucket at the center of the spillway section, relocation of Olmos Drive roadway from the top of the dam to a location approximately 107-m (350-ft) downstream in the tailwater floodplain, construction of a new gate operating room atop the nonoverflow section, location and reconstruction within the dam structure of major telephone trunk lines and an inspection gallery.



The original project contract price was \$8.6 million; final cost was within \$100,000 of that figure.

## Santeetlah Dam

Santeetlah Dam is located in Graham County in western North Carolina, south of the Great Smoky Mountational National Park. The 320-m-long , 65-m- (213-ft-) high concrete gravity structure was completed in 1928 as part of a hydroelectric project. The first modification was made to the dam in 1930 in an attempt to correct seepage problems. Massive amounts of concrete were placed on abutment blocks 6, 10, 21, and 24. Seepage recurred, and the same repair method was used for abutment blocks 7, 8, 9, 22, 23, and 25 (Figure 143). Repairs were also made in 1950 and 1967.

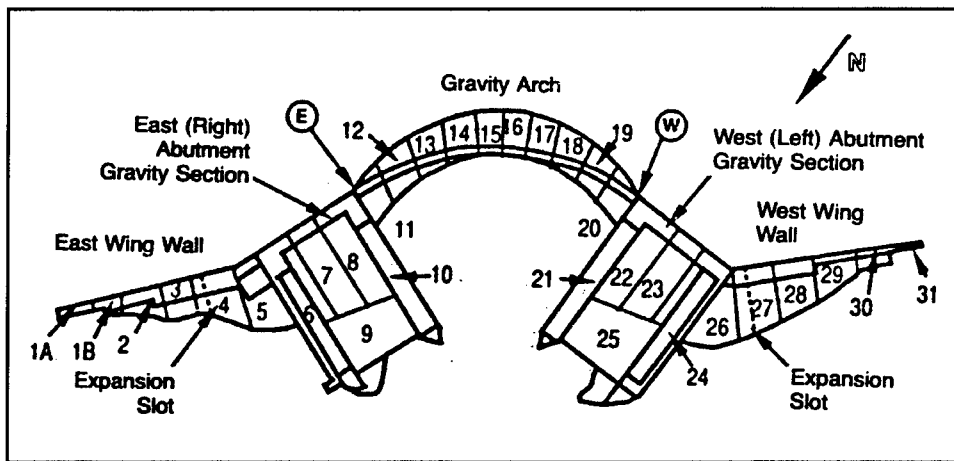

Figure 143. Layout of Shanteetlah Dam (from Bruce and Porcellinis 1991)

Routine measurement of deformation of the dam crest over a period of 25 years indicated that the crest had ratcheted (moved upstream in a cyclically increasing manner) since the 1930 and 1938 modifications, and the seepage volume had increased considerably. By 1987, seepage in the west abutment had reached over 4,000  $\mu\text{m}$  (1,050  $\text{gpm}$ ) and was entering the lower gallery at higher pressures and over larger areas than ever before. In addition, seepage from the downstream side of the gallery was also apparent (Bruce and De Porcellinis 1991).

Old construction records revealed that when repairs were made in 1930 and 1938 no structural connection was used to bond the new concrete to the old, except near the crest. Therefore, engineers attributed the steady ratcheting of the crest to thermal expansion caused by seasonal cycling. Displacements occurred along the interface between the original and new concrete. These upward deformations also caused construction joints to open seasonally, creating the possibility for concrete leaching (Bruce and De Porcellinis 1991).

A decision was made to use epoxy-resin grout to seal the joints and cracks in Santeetlah Dam. A 23-m- (75-ft-) long section in the most critical area was selected for treatment, which was conducted from within the lower gallery. The gallery is located about 3 m (10 ft) above the foundation and 4.5 m (15 ft) back from the upstream face. Cores up to 6 m (20 ft) long were taken from the upstream section of the dam to allow for inspection of the joints (Figure 144). The core holes revealed that water flows were traveling through the joints; the cores indicated the concrete was sound. A number of holes intercepted flows of 400  $\mu$ pm (105 gpm) at full hydrostatic head (Bruce 1989).

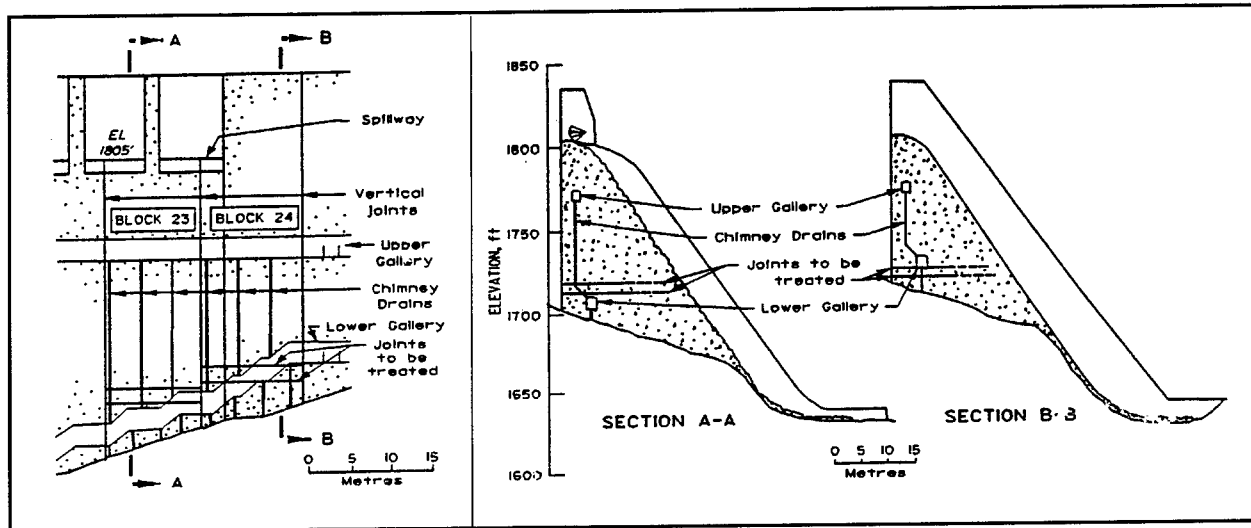

Figure 144. Investigation and treatment plan for horizontal joints in Blocks 23 and 24 at Santeetlah Dam (from Bruce 1989)

After all the primary holes had been drilled and the data carefully considered, the systematic epoxy-resin grouting program was begun. Disposable packers designed for high-pressure grout injection were installed in each hole. Resin was injected through one packer until it could be observed in the next hole; the injection nozzle would then be moved to that injection port, thus ensuring that each joint was filled with the epoxy resin (Bruce 1989).

A secondary phase of drilling and grouting was then conducted to confirm the effectiveness of the first and to allow for re-injection of any areas that needed more grout. Resin thicknesses up to 10 mm (0.4 in.) were found, substantiating the actual width of joint openings. Once the treatment was completed, holes were drilled for a final verification of grout penetration. These holes revealed the secondary grout had penetrated even microfissures (Bruce and De Porcellinis 1991).

By the conclusion of the work in the fall of 1988, the total flow into the grouted section was about 120  $\mu$ pm (32 gpm), virtually all of which was entering the gallery through vertical roof drains and fissures well above the levels grouted. The concrete of the upstream gallery wall had begun to dry, and flows from secondary longitudinal roof fissures and from the downstream gallery wall

were also stopped completely. This performance has persisted during the maximum reservoir levels (Bruce 1989).

## Shepaug Dam

Shepaug Dam is located on the Housatonic River near Sandy Hook, Connecticut. The dam was completed in 1955 was constructed to provide flood control and power generation. The concrete buttress, gravity dam is 40 m (130 ft) high and 430.4 m (1,412 ft) long. A stability reassessment in the 1980's found that the dam would be overtopped 6 m (20 ft) by the PMF. Therefore, high-capacity prestressed rock anchors were designed and installed to safeguard the dam against overturning. This case history is a summary of a report by Bruce and Clark (1989).

The standard inverted cone method was applied to the weight of rock in the potential failure volume to calculate the overall stability requirements of the dam. The design specifications and placement of the anchors was based on the stability requirement of the dam. Specifications called for 83 anchors for the crest and 14 for the spillway, each with individual working loads from 4,372 to 8,273 kN (983 to 1,860 kips). Crest anchors were installed from vertical to 0.04 radians (2.3 deg) upstream, and the spillway anchors were installed 24 m (80 ft) below on the downstream spillway face and inclined at a 0.86-radian (49-deg) angle from horizontal.

The 254-mm- (10-in.-) diam anchor holes for the crest and spillway were drilled with a rotary percussive down-the-hole hammer mounted on a diesel hydraulic drill rig. For the improvement of hole straightness and linearity, spiralled centralizers were placed behind the hammers, and 6-m- (20-ft-) long barrelled rods were used. The holes were then cleaned with potable water. Each hole was over-drilled by 0.9 m (3 ft) to allow for debris that remained in the holes. Each hole was water-pressure tested to ensure tightness before the anchors were installed, and all holes passed the test.

Each anchor tendon consisted of groups of 15-mm- (0.6-in.-) diam, low-relaxation, seven-wire steel strand of 261 kN (58.6 kips) guaranteed ultimate tensile strength (GUTS). At design working load, each strand would be operating at 60 percent GUTS, with temporary test load stresses of 80 percent GUTS being reached before lock-off at 70 percent. Tendons varied from 20.7 to 62.8 m (68 to 206 ft) long, including 2 m (6-1/2 ft) of "tail" and consisting of 28 to 53 strands. Maximum tendon weight was therefore about 4.5 Mg (5 tons).

In the bond length, the strands were noded and centralized at 3-m (10-ft) centers to promote grout penetration around the strands and to ease installation. However, it was in the free length that a major innovation was made, principally in order to effect a major cost saving to the owner. In all 14 spillway anchors and in 8 crest anchors where the depth-to-top-of-bond zone was less than 15 m (50 ft), the conventional lock-off system was used: the prestress is maintained in the free length after testing by using a top anchorage assembly, with wedges

gripping the strands and bearing on the concrete of the dam crest. The free length of each strand is protected by an individual, full-length, greased sheath and surrounded after lock-off by the secondary grout. For all the other anchors, however, the load was maintained by bond between the bared upper part of the free length (about 11 to 17 m (36 to 55 ft) long) and the secondary grout. This scheme saved the considerable cost of coring large-diameter recesses in the dam crest to accommodate the conventional top anchorage hardware. The 75 anchors of this type were referenced as secondary bond anchors.

### **Sherman Island Dam**

Sherman Island Dam is located on the Hudson River approximately 5 km (3 miles) southwest of Glen Falls, New York. The dam was a hollow-arch concrete dam owned by Niagara Mohawk Power Corporation.

Over time the dam, which is more than 70 years old, suffered concrete damage as a result of chemical reaction and cycles of freezing and thawing. Despite extensive maintenance the deterioration continued to occur. By the mid-1980s, severe cracking in the dam's arches and buttresses was allowing water to penetrate the structure and cause structural damage (*Concrete Construction* 1994). A cellular cofferdam was installed to allow for a careful evaluation of the structure. This evaluation resulted in the decision to conduct a major rehabilitation, including modifying the buttress-arch design of the dam to a flat-slab design.

The first step in the rehabilitation was to dewater the area between the cellular cofferdam and the existing 31-arch dam. Submersible pumps were used to lower the water in 2-m (6-1/2-ft) lifts. Previously installed tiltmeters and vibrating wire piezometers were used to monitor the procedure (Beckman and Hulick 1991).

Once the area was dewatered, silt was removed and general demolition began. Block curtain walls between the buttresses along the downstream face of the dam, which had been installed many years ago to minimize the impact of cycles of freezing and thawing, were removed.

Next came the demolition work on the dam. The foundation and lower buttress portions of the dam that had not been exposed to weathering were sound and usable; therefore, total concrete demolition was not required (*Concrete Construction* 1994). The entire reinforced concrete arch roof and selected areas of the buttresses would have to be removed (Figure 145). Partial removal of the concrete arches and severing reinforcing steel would affect the stability of the structure and increase the need to restrict heavy vibration. The contractor elected to use diamond wire-cutting technology to remove the concrete at Sherman Island Dam because of its successful use in recent years at large hydro-schemes.

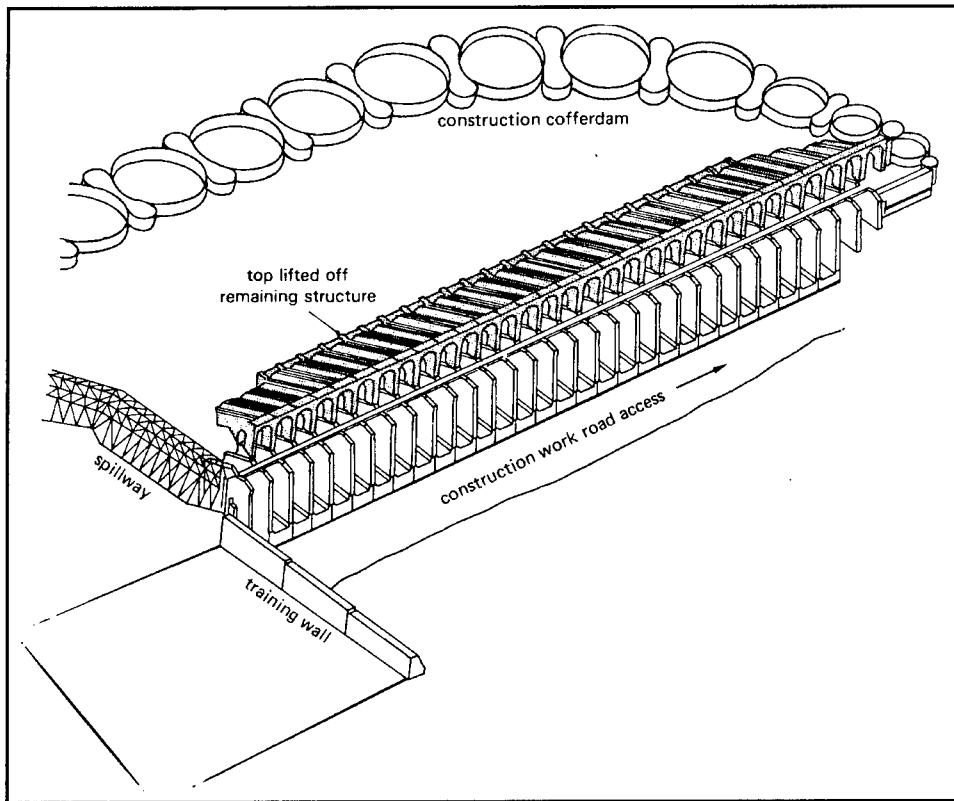

Figure 145. Overview of Sherman Island Dam rehabilitation project. The arch section of the dam was removed by diamond wire cutting (from Beckman and Hulick 1991)

A typical wire-cutting configuration and diamond wire are shown in Figure 146. Electric-, gasoline-, or diesel-powered units provide hydraulic power to the motor and cylinder. An operator controls the cutting rate with mechanical or electrical controls. Typical cutting rates are from 1 to 4 sq m/h (1.2 to 4.8 sq yd/h); the linear speed of the wires approaches 30 m/s. At peak operation at the Sherman Island Dam project six wire saws were running at different locations (Beckman and Hulick 1991).

Work began on the upper arch sections. Two transverse cuts were made between the arches and buttresses in each bay across the 31-m (102-ft) width of the dam (Figure 147), and then three longitudinal cuts were made in steps along the 185-m (600-ft) length of the dam. The cut angle allowed the concrete arch to remain in position, without any additional shoring, until the contractor was ready to remove it. Access holes for the diamond wires, 20 to 40 mm (0.8 to 1.6 in.) in diameter and approximately 700 mm (28 in.) long, were drilled with percussion drills at the points where transverse cuts intersected longitudinal cuts. The wire saws were operated from the ground, from scissor lifts, or on large platforms anchored to the face of the dam. Some cuts required wires up to 80 m (260 ft) long (Beckman and Hulick 1991).

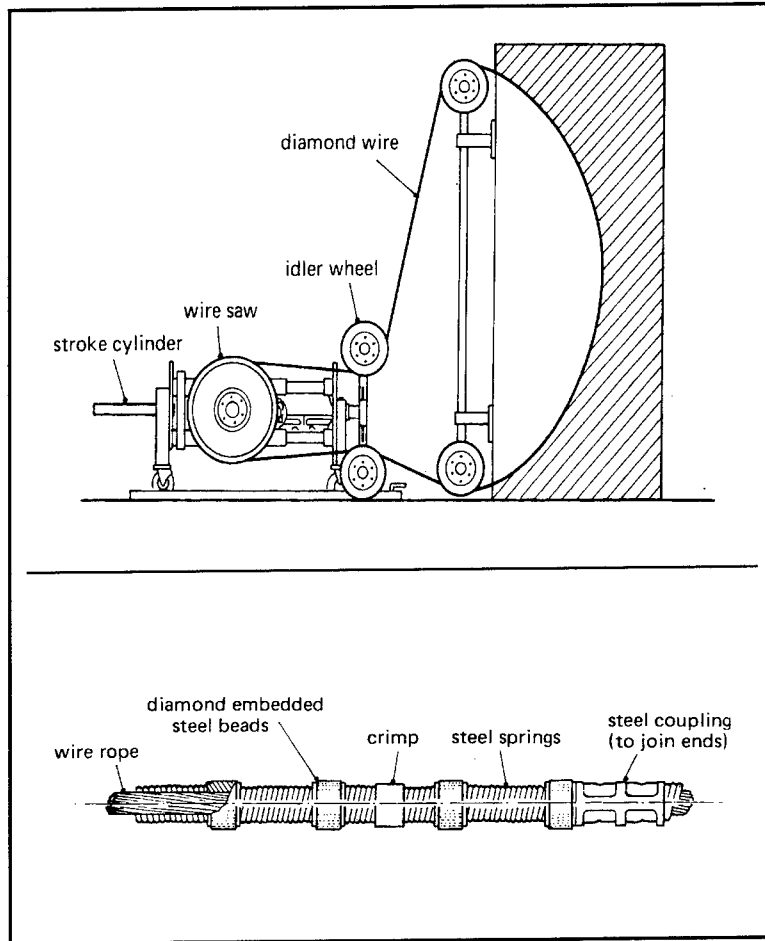

Figure 146. Typical configuration of a diamond wire-cutting machine and wire (from Beckman and Hulick 1991)

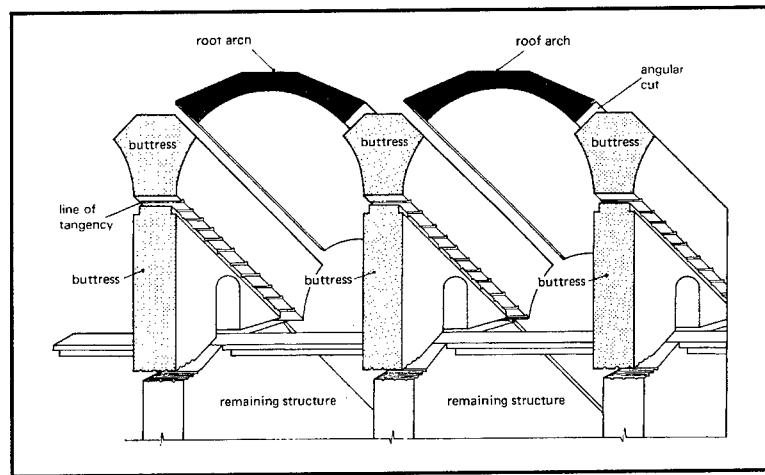

Figure 147. View of two arches prepared for removal at Sherman Island (from Beckman and Hulick 1991)

Using the transverse and longitudinal cutting pattern allowed the contractor to remove sections in a checkerboard fashion. Buttress No. 4 was removed to grade to facilitate access through the dam. To prevent unwanted deflection of the remaining buttresses, temporary I-beam braces were bolted across each bay and then removed after arch sections on either side of a buttress had been lifted (Beckman and Hulick 1991).

Once the arches had been removed, the buttresses were drilled horizontally through the 1-m- (3-ft-) thick section along the line of tangency. Then hydraulic rock splitters separated the buttress along the unreinforced construction joint. Additional buttress sections were removed adjacent to the inspection gallery walkway, along with smaller sections at the bulkhead toe. Finally, bulkhead toe sections and other sections of concrete were removed from the lower upstream edge of the dam (Figure 148). The main scope of the concrete cutting work was completed within the required 16-week schedule (Beckman and Hulick 1991).

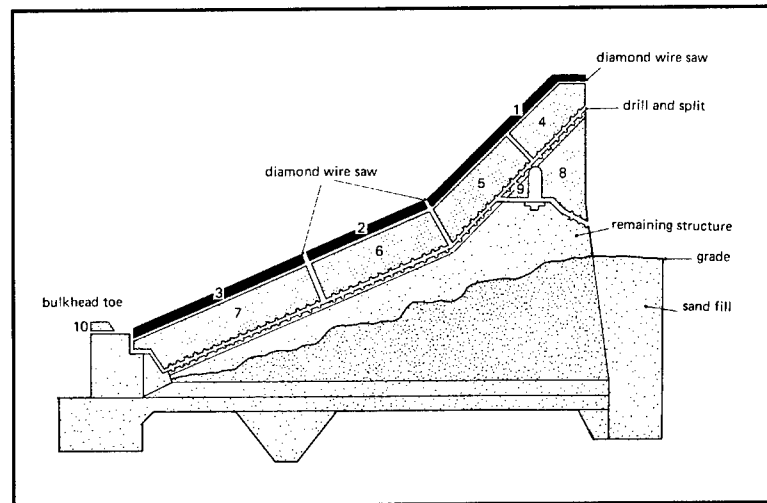

Figure 148. Order of removal of typical transverse section of Sherman Island Dam

Once concrete removal was completed, reinforced steel was fabricated to recap existing buttresses, and new concrete buttresses and slabs were installed. Specifications called for 27.6-MPa (4,000-psi) concrete with a maximum w/c of 0.50, epoxy-coated reinforcing bars, galvanized steel fasteners, and an integral-loop PVC waterstop. This type of waterstop was selected because its built-in system for attaching the waterstop to the reinforcing makes installation easier than conventional waterstop installation; it remains in place during concrete placement and consolidation, it helps create a mechanical bond between the cured concrete and the waterstop, and it contains no holes, thus eliminating water penetration (*Concrete Construction* 1994).

The project, which began in October 1990, was completed in May 1992. It required approximately 1,360 t Mg (1,500 tons) of reinforcing, 13,760 cu m (18,000 cu yd) of concrete, and 3,660 lin m (12,000 lin ft) of waterstop at a cost

of approximately \$13 million. The dam is being monitored by a network of sensors installed in and around the dam. Since Sherman Island Dam resumed operation in 1992, it has remained leak-free (*Concrete Construction* 1994).

## Snake River Dams

The Upper Salmon, Lower Salmon, and Bliss Dams, which are owned by the Idaho Power Company, are located on the Snake River in Idaho. When the power company decided to replace the spillway radial gate seals and paint the spillway gates at these dams, the contractor for the project had to devise a method for dewatering the work areas at all three dams because use of a conventional, drop-in-place bulkhead was not feasible. None of the dams have stoplogs or bulkheads to seal the spillway bays for dewatering (only Bliss has bulkhead slots), vehicular access on the spillways, and spillway hoist bridges capable of carrying heavy loads such as a crane or stoplogs. Also, the reservoirs could not be lowered without a loss in power-generating revenue and possible environmental consequences.

The contractor elected to use a floating bulkhead at all three dams. Lux and Regner (1991) described the design and advantages of floating bulkheads. This case history is a summary of their report.

A floating bulkhead consists of individual floating caissons linked together to form a unit. Individual caissons, which can be used separately, have a flotation compartment and another compartment that is filled with water to sink the caisson or emptied to float it (Figure 149). Each caisson is lowered into the water and then towed into position by a boat. The caissons are pinned together to form the bulkhead, and then individual caissons are filled with water so that they slowly submerge in a controlled manner, pulling the rest of the units behind (Figure 150). The unit resembles a giant garage door as it floats on the water. Installation of a floating bulkhead has required less than 2 hr.

Articulated floating bulkheads have several advantages over conventional bulkheads or stoplogs: the bulkheads can be removed and reused at other projects; they do not need a large-capacity crane for placement; the floating bulkhead can be used with or without bulkhead slots; and they can be used as barges or work platforms when they are not needed as bulkheads.

Four general requirements were established for design of the floating bulkhead. First, each caisson must float or sink, depending on the amount of water it contains. Second, the bulkhead must be able to resist the hydrostatic pressures of the dewatering process. Third, upon removing the bulkhead, each caisson must ascend slowly to reduce the potential danger of heavy caissons ascending quickly, rising above the water, and damaging the dam and bulkhead or injuring workmen. Fourth, the bulkhead caissons must be small enough to be hoisted out of the water and transported to other dams by truck.



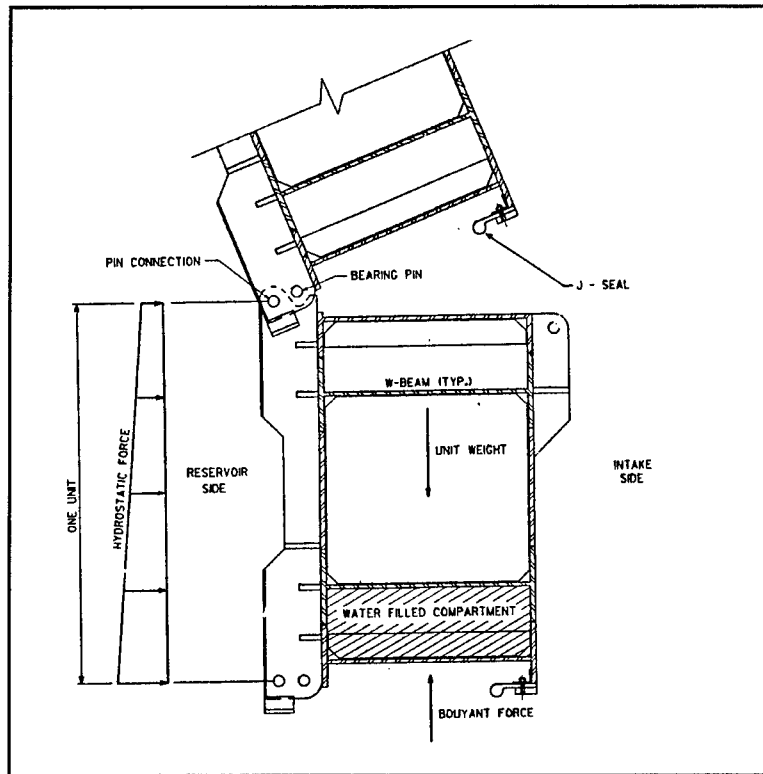

Figure 149. Individual floating caisson used to construct floating bulkhead at Snake River Dams (from Lux and Regner 1991)

The steel sections used for the caissons are W-shapes in combination with steel plates. The W-beams have very low weight-to-area ratio, which is necessary to achieve the required buoyancy. Initially, hinges were used between caissons because they made construction of a bulkhead easier. However, several benefits were realized. When only selected compartments in alternate caissons are filled, the bulkhead remains almost weightless in the water and is, thus, easier to maneuver and can be controlled with a hoist as small as a 1,800 kg (2-ton) capacity on each side of the bulkhead. (The dry weight of the bulkhead is approximately 82 Mg (90 tons).) The bulkhead can be placed and removed in minimum time. This factor is especially important should there be an emergency. Also, diver time in the water is kept to a minimum, resulting in a cost savings. Placing the floating cofferdam is safer because little equipment is used and less work has to be performed underwater than with conventional bulkheads.

The hinges are designed to allow 3.14 radians (180 deg) of movement, so pins are stressed only when the bulkhead is being installed or removed. When the bulkhead is either totally horizontal or vertical, the caissons are in direct contact with one another, leaving the pins free to be removed or installed without shear forces on them.

Three key locations require a seal: between the caissons, at the pier nose or bulkhead slot, and at the base of the bulkhead. Wood is placed against concrete

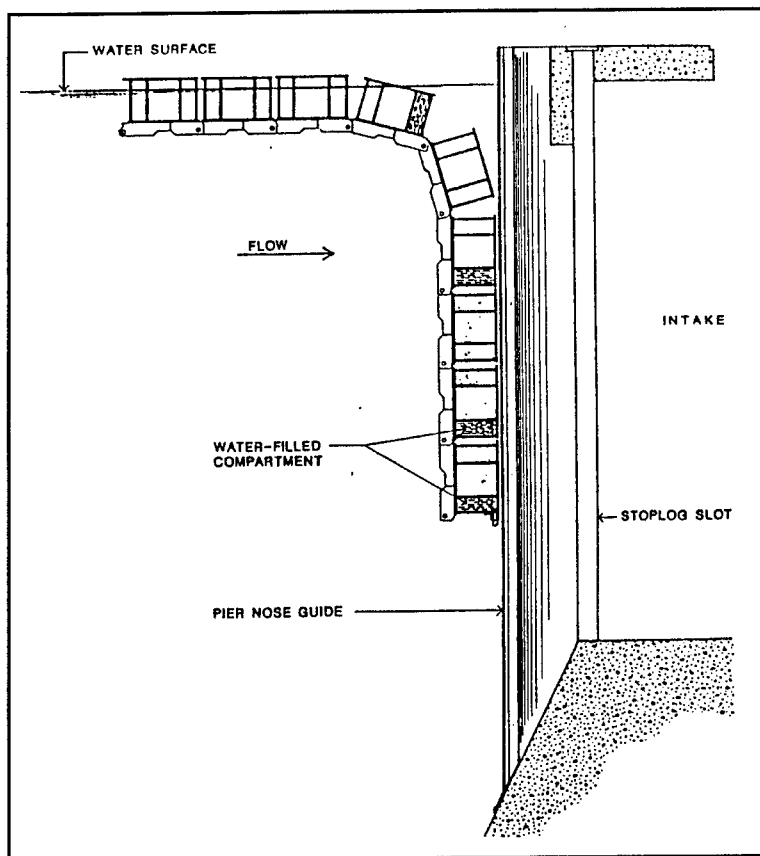

Figure 150. Floating caissons joined to form floating bulkhead at Snake River Dams (from Lux and Regner 1991)

because of its ability to conform to irregular, rough surfaces and its low cost of replacement. Rubber seals are used at steel surfaces. Small leaks through and around the bulkheads are expected; however, construction crews installing the bulkheads have sealed leaks with such materials as cinders and rubber hose.

Information about the three Snake River dams that was used to design the bulkhead used in their rehabilitation is shown below.

| Item                  | Bliss, ft | Lower Salmon, ft | Upper Salmon, ft |
|-----------------------|-----------|------------------|------------------|
| Max. normal pool el   | 2,654.0   | 2,798.6          | 2,880.4          |
| Pool fluctuations     | 1.5       | 2.0              | 0.0              |
| Spillway crest el     | 2,624.0   | 2,783.5          | 2,865.4          |
| U/S apron or sill el  | 2,624.2   | 2,762.0          | 2,861.8          |
| Maximum design head   | 30.8      | 36.6             | 18.6             |
| Spillway span at gate | 39.0      | 30.0             | 30.0             |
| Spillway span at pier | 49.0      | 38.0             | 38.0             |
| Bulkhead slots        | Present   | None             | None             |

Note: Multiply feet by 0.3048 to obtain metres.

The floating bulkhead consisted of eight 12.2-m- (40-ft-) wide by 1.25-m- (53-in.-) high caissons. It spanned 11.6 m (38 ft) under a water head of 11 m (36 ft) at Lower Salmon Dam, the most critical structure. The final major design concern was the durability of the newly fabricated structure. Special attention was given to the welds to assure that faying surfaces would not come in contact with water and corrode. All of the interior surfaces were sprayed with linseed oil. The compartments that are filled with water received applications of linseed oil at regular intervals. The exterior surfaces were painted with a coal-tar epoxy. Construction cost for the bulkhead was approximately \$190,000.

At both Upper Salmon and Lower Salmon Dams, the spillway pier noses and an upstream concrete apron were used as the bearing surfaces for the bulkhead seals. At Bliss Dam, the existing 0.33-m- (13-in.-) wide bulkhead slots were used as the sealing surfaces for the floating bulkhead. At this location, each caisson was installed and removed individually. Each end of the caisson had a tapered end which allowed the bulkhead to be fitted into the bulkhead slots.

### **Soda Dam**

Soda Dam is located on Bear Creek in Soda Springs, Idaho. The dam, owned and operated by Pacific Power-Utah Power, was constructed in 1925. It consists of a nonoverflow gravity section, an integral intake powerhouse section, a gated-spillway section, and a short earth-embankment section. The 64-m- (10-ft-) long, 22-m- (72-ft-) high nonoverflow gravity section of the dam was constructed in 2- to 24-m- (65- to 85-ft-) wide monoliths placed in 1.5- to 2-m- (5- to 6.5-ft-) thick lifts (Figure 151).

Minor leakage along lift joints has occurred during the life of the project. In the 1950s, a thin layer of shotcrete was placed on the downstream face of the dam in an effort to arrest concrete deterioration. Initially, this layer may have protected the surface from further deterioration, but ultimately, it probably contributed to increasing the rate of deterioration as minor leakage resulted in water being trapped behind the shotcrete. Inspections during 1990 revealed the existing shotcrete layer was delaminating from the underlying surface. This discovery prompted an investigation to determine the extent of deterioration. This case history is a summary of a report on the investigation and repair of Soda Dam by Marold, Koniarski, and Bruen (1992).

Much of the shotcrete layer covering the downstream face was removed to permit an inspection of the surface. Six core holes, ranging from 1.4 to 3.5 m (4.5 to 11.5 ft) deep, were drilled in the downstream face, and two vertical core holes were drilled through the entire height of the structure into the foundation. Samples were retrieved for compressive testing and petrographic analyses. The investigation revealed the following: in the upper 3 m (10 ft) of the structure and on the downstream face, advanced deterioration was found in the outer 0.3 to 0.6 m (1 to 2 ft) of concrete; microcracking with soft, carbonate-like fillings in the surface concrete on the downstream face indicated alkali-aggregate

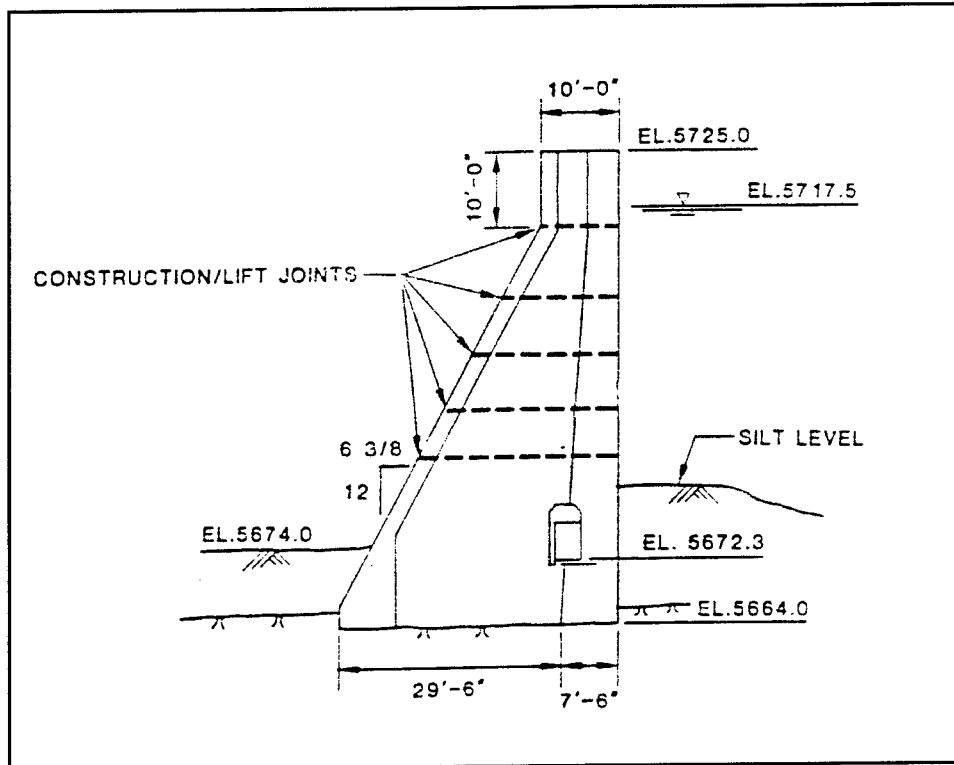

Figure 151. Nonoverflow gravity dam section at Soda Dam (from Marold, Koniarski, and Bruen 1992) (multiply feet by 0.3048 to obtain metres; inches by 25.4 to obtain millimetres)

reactivity; compressive strengths in the downstream face and upper 3 m (10 ft) of the structure ranged from 10 to 20.7 MPa (1,500 to 3,000 psi), while concrete in the body of the structure had compressive strengths ranging from 20.7 to 27.6 MPa (3,000 to 4,000 psi); reactive aggregates were identified as part of the concrete, especially (rhyolites and other silica-rich aggregates); cracking was attributed to swelling of the calcium-alkali-silica gel by-product of the alkali-aggregate reaction and subsequent cycles of freezing and thawing.

The investigation also revealed that the nonoverflow gravity section was stable, structurally sound, and strong enough to resist overturning or sliding in its present condition for the normal operating loading. However, over time, continued seepage of water through cracks and joints could weaken the structure along horizontal construction joints (Figure 152). Once a large enough area was weakened, a sliding failure or increased leakage could result. A decision was made to eliminate the leakage through the structure. Several remedial techniques were considered. Chemical grouting of construction joints was selected as being the most cost-effective and best technical alternative.

A hydrophilic, polyurethane foam chemical grout was selected for the repairs. When this grout encounters water, it expands 10 to 15 times its original volume and becomes a flexible foam grout that has low permeability. It adheres to concrete surfaces.

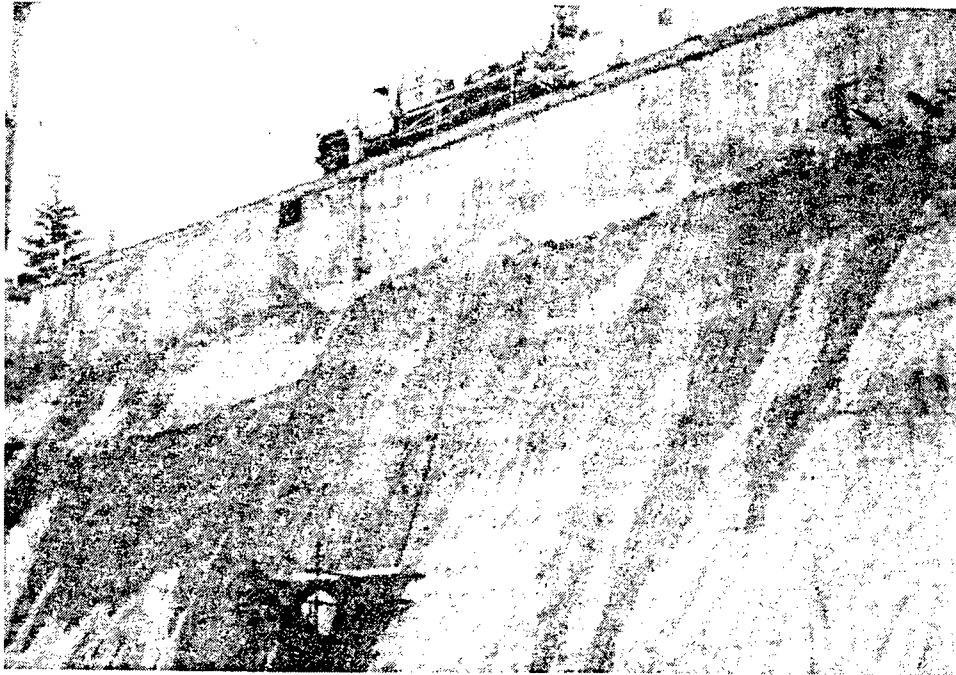

Figure 152. Seepage on downstream face of gravity section of Soda Dam (from Marold, Koniarski, and Bruen 1992)

Initially, a conventional grout injection program was tested on monolith No. 1. This method was ineffective because of the low permeability of the joints and the use of low injection pressures (0.10 to 0.55 MPa (15 to 80 psi)). Therefore, an alternate method of grouting from the upstream face was chosen. The reservoir was lowered to el 5,680 (13.7 m (45 ft) below crest level) to permit replacement of spillway piers. Construction monolith joints and cracks were identified and mapped on the upstream face of the structure; 244 lin m (800 lin ft) of cracks were identified as requiring treatment.

A short testing program revealed that a hole spacing of 0.5 m (1.5 ft) would assure maximum grout penetration between holes. Holes 16 mm (5/8 in.) in diameter were drilled to intersect the joint/crack a minimum of 254 mm (10 in.) behind the upstream face. Grout injectors, 152-m- (6-in.-) long mechanical packers, were installed in each hole. Water was preinjected for a period of 5 min to test the tightness of the crack, to ensure that the polyurethane grout would be activated, and to maximize grout penetration.

A total of 1,098 ℓ (290 gal) of polyurethane grout was injected into 450 holes for the treatment of 192 lin m (630 lin ft) of monolith and lifts joints (Figure 153). Grouting pressures were increased to a maximum 13.8 MPa (2,000 psi) and generally averaged 4.8 to 8.3 MPa (700 to 1,200 psi). Grout acceptance varied from 0 to 19 ℓ (5) gal per hole, with only 1 percent of the holes actually tight. The overall average grout acceptance per linear foot of joint/crack treated was 2.5 ℓ (0.65 gal), with higher acceptance in the upper 3-m (10-ft)

section of the dam, which had more deterioration and microcracks. In this zone, maximum grout penetration along microcracks to a distance of 2 m (6 ft) was realized.

The downstream face of the dam was not rehabilitated. Since the chemical grouting program was completed in late 1990, there has been no measurable leakage through the concrete dam. Additional chemical grouting may be performed if further leakage occurs. If there is no further leakage, no protection of the downstream surface is anticipated to arrest further damage from cycles of freezing and thawing.

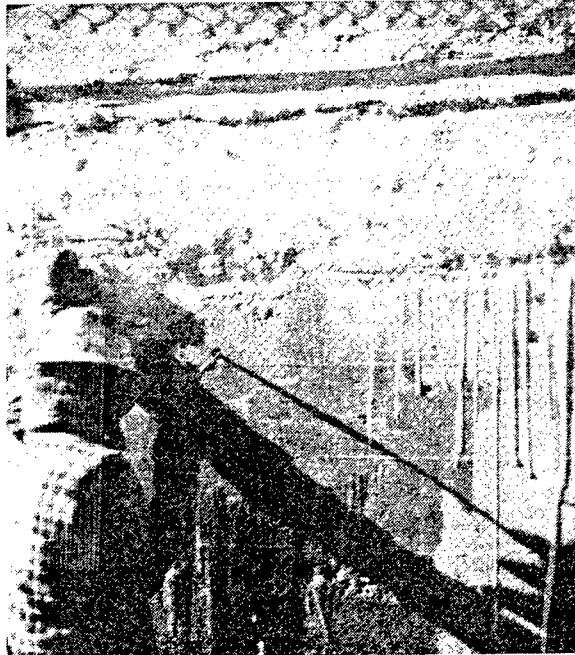

Figure 153. Chemical grouting of upstream face of Soda Dam (from Marold, Koniarski, and Bruen 1992)

The actual cost to complete the chemical grouting program was \$196,000, which was within the original estimated range of costs (Marold, Koniarski, and Bruen 1992).

### Stillwater Dam

Stillwater Dam is located on the Beaver River in the Town of Webb, NY. Hudson River--Black River Regulating District, a public benefit corporation, operates the dam for flood and pollution control, as well as for hydropower production and recreation.

The dam has a maximum height of 17 m (55 ft) and is made up of three sections that span 387 m (1,270 ft) over three natural rock ravines. The northern earth embankment is 183 m (600 ft) long. The 108-m- (355-ft-) long center concrete gravity dam contains a 12-m- (40-ft-) long gatehouse structure and a 73.5-m- (41-ft-) long flashboard regulated spillway. Thirty and four-tenths metres (30.4 m (100 ft)) from the center section, the 96-m- (315-ft-) long southern earth embankment is 6 m (20 ft) high. A 60-m- (200-ft-) long spillway located 457 m (1,500 ft) south of the southern embankment section is 1.2 m (4 ft) high. Stillwater Dam impounds 134.5 billion litres (4.75 billion cu ft) of water.

The reservoir is full during most of May and June. From June to October, it is drawn down to supplement the lower basin; from November to December, the level is lowered to provide storage for spring runoff. Part of the present

structure was built in 1890. In 1923, the main dam was reconfigured and the auxiliary spillway was added. In 1969, the dam was covered with gunite because of surface deterioration that included exposed aggregate. The deterioration was attributed to the exposure of the nonair-entrained to the severe mountain climate. The gunite separated from the original concrete and peeled off, a result of leakage through construction joints. Leakage at several of the gates, cavitation damage in the discharge chutes, and the condition of the old concrete were also areas of concern.

In 1978, the U.S. Army Corps of Engineers produced a Phase 1 Inspection Report that contained a PMF estimation of 1,150 cms (40,700 cfs), a high-water level of 514.5 m (1,688 ft), and possible stability deficiencies; the report recommended that deteriorated concrete be removed and replaced and that trees and brush be removed from the embankments. This case history is a summary of a report on Stillwater Dam by Zeccolo (1992).

In 1987, a hydro plant was completed and became operable at the site. The Federal Energy Regulatory Commission required a safety evaluation of the dam by an independent contractor. Because of the scope of the evaluation, the District was forced to accelerate its time schedule for rehabilitation of the dam.

Extensive research was done, including locating notes and photographs from the 1920s construction. These studies, completed in 1988, reduced the estimated outflow of the PMF to 620 cms (22,000 cfs) and the water elevation to 1,683 ft. A stability analysis of the overflow section (concrete dam) based on the research data satisfied all previous stability concerns. The only remedial work to the concrete dam was the installation of a 513-mm- (15-in.-) thick reinforced concrete overlay and the placement of six rock anchors in the log way vicinity. Later on, the rock anchor installation confirmed research data that a rock/concrete keyway always existed and that sliding was never a problem.

As a result of a slope stability analysis performed on the north and south embankments, piezometers were installed in the earth embankments, four in each dike, and a new recording system based on the reservoir level was implemented. The readings of the newly installed piezometers demonstrated that the south dike was not functioning as well as the north dike and that seepage through the clayey core was occurring.

A geotechnical consultant was engaged to design an inverted filter for the south dike and the northern end of the north dike. Bids were received on 8 September 1989 in the amount of \$38,000 for approximately 1,150 cu m (1,500 cu yd) of material. The new inverted filter was completed in November 1989. An earthen berm built in 1923 was part of the containment area for the new filter drain, and an outlet ditch was equipped with a "V" notch weir for measuring seepage.

The entire downstream slope of the south dike was reinforced by the new inverted filter. The 1.5-m (5-ft) depth of filter material was armored by a 1.5-m (5-ft) cover of 102 to 152-mm (4- to 6-in.) surge stone. Rock spoil from the

hydroplant excavation had been spoiled along the upstream slope of the south dike, widening the top width from 4.6 to 10.7 m (15 to 35 ft). This rock spoil needed to be removed and regraded because it was causing a surcharge on the upstream slope of the embankment. The south dike top width was returned to 4.6 m (15 ft), and upstream slope was flattened to a 4:1 slope.

The concrete overlay was installed on the main dam, the auxiliary spillway, the crest, and 1.5 m (5 ft) down the upstream face of the dam during the winter months when the reservoir level was drawn down. The concrete overlay and rock anchor installation was completed in August 1989 at a cost of \$538,000.

The leaking gates in the gatehouse were replaced with Rodney Hunt Gates--two 1.2 m (4 ft), one 0.9 m (3 ft), and two 0.6 m (2 ft). A liquefied petroleum gas engine was purchased to operate the drive mechanism for the gates. This was considered an expedient choice because of the remote setting of the dam.

### **Vesuvius Dam Spillway**

Vesuvius Dam Spillway is located in the Wayne National Forest in southern Ohio. The dam, which was constructed by Civilian Conservation Corps workers, was completed in 1939. The earth-fill dam impounds a lake that is used primarily for recreation. The spillway is composed of a side channel overflow section, a chute channel, a stilling basin, and a lower channel (Figure 154).

Soon after the dam was completed, progressive concrete deterioration in the spillway was noted. Repairs were made to the spillway wall and floor joints in 1949. A number of floor slabs were replaced, and prepacked aggregate and grout were used to repair the walls in February 1955. The entire floor below the overflow section was replaced in 1964, and additional repairs were made on the walls. The deterioration has been attributed to lack of quality control during construction, the use of tongue and groove joints, inadequate expansion joints, winter construction, and cycles of freezing and thawing.

The concrete continued to deteriorate--cracking, spalling, raveling rock pockets, and efflorescence were evident. By 1977 there was concern about the structural integrity of the structure, so a decision was made to inspect all concrete areas in the spillway and pond drain channels and to make repairs where needed. This case history is a summary of a report by Coghlan and Vanderpoel (1980) on the investigation and repairs made at Vesuvius Dam spillway.

A Schmidt Rebound Hammer and a machinist hammer were used to "sound" the concrete to identify areas of deterioration. The quality of the concrete tested with the machinist hammer was determined by whether it made a "thunk" or a "ring" when it was hit with the hammer. This technique was correlated with test results from areas inspected with the Schmidt Rebound Hammer. Concrete equivalent to an indicated Schmidt Rebound Hammer strength of less than 17 MPa (2,500 psi) was marked for repair.



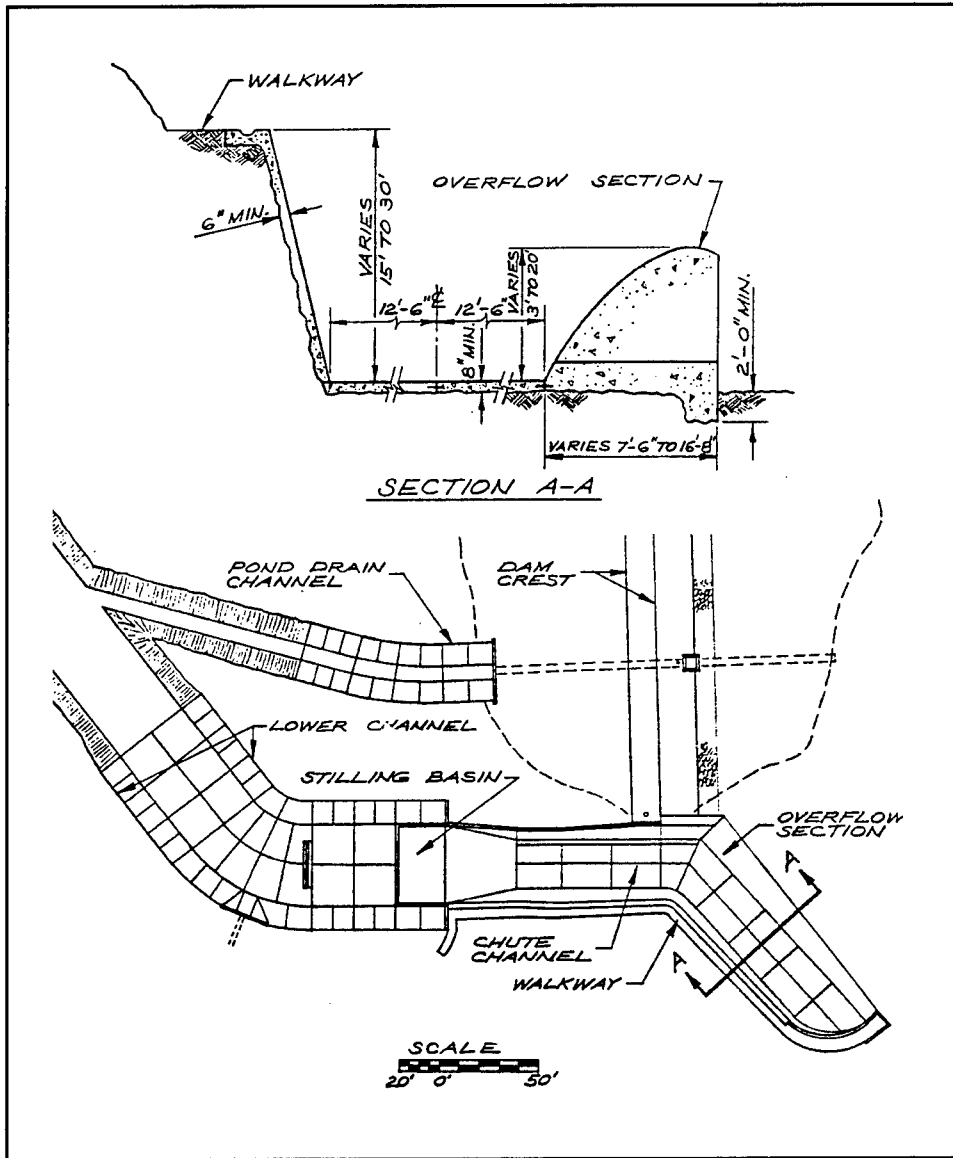

Figure 154. General plan for Vesuvius Dam and spillway (from Coghlan and Vanderpoel 1980) (multiply feet by 0.3048 to obtain metres; inches by 25.4 to obtain millimetres)

To allow contractors to choose the repair materials and methods they wanted to use, the owners used an end-product specification for the bidding, with the stipulation that contractors would demonstrate their ability to make the repairs with the materials and methods of choice. Pay was based on repaired area rather than on material volume because of the variety of repair material costs. Wall repairs were further classified as shallow or deep to avoid inequities and conflicts. The reservoir level could be lowered only 152 mm (6 in.) from April 15 to October 1 because of recreational use, so a provision was added to the contract to allow the contractor to place a dike on the spillway to allow for additional storage. The dike could be a maximum of 152 mm (6 in.).

The lowest of four bidders was an experienced shotcrete firm from Alabama. Repair work began in May. Chipping hammers were used to remove the deteriorated concrete. Then the exposed surface was washed and sandblasted. Wire mesh reinforcing was installed, and the shotcrete was sprayed on the prepared area to an overdepth. The surface was troweled smooth and brush finished. Because large repair surfaces were noticeably rougher than the original surface, the concrete in these areas was removed and repaired in 0.9-m (3-ft) sections. Plywood forms with chamfer strips served as a straight-line guide and support for finishing longer edge repairs. The repairs were completed in July.

The last step in the contract for repairs was to sandblast the walls of the spillway channel to clean them and then treated the walls with a double coat of linseed oil. The linseed oil was used to improve the weather resistance of the existing concrete as well as to blend the appearance of the old and new concrete. However, the concrete did not absorb the same amount of the oil: old concrete became darker, new concrete remained light colored, and the area around the repairs became very dark, especially where the area was smeared with grout.

### **Waste House Dams No. 1 and 3**

Waste House Dams No. 1 and 3 were constructed by the Philadelphia and Reading Coal and Iron Company in 1884 and 1901, respectively. They are now owned and operated by the Mahanoy Township Authority and serve as a part of the public drinking water distribution system for Mahanoy City, PA, and its surrounding communities.

Waste House Dam No.1 is a 16.8-m- (55-ft-) high, 122-m- (400-ft-) long earth-fill structure that drains a 2,470,000-sq m (610-acre) area and impounds a 215,900-cu m (175-acre-ft) pool at normal storage capacity. Nine hundred fourteen meters (914) (3,000 ft) upstream of Dam No.1, Waste House Dam No. 3 drains a 919,500-sq m (245-acre) area. It is an 11.6-m- (38-ft-) high, 293-m- (960-ft-) long earth embankment dam that impounds a 166,500-cu m (135-acre-ft) pool at normal storage capacity.

When the USACE began its Phase I Inspection Program during the late 1970s, these dams, along with others owned by the Authority, were evaluated according to new dam safety design standards. At the same time, the Pennsylvania Department of Environmental Resources, Division of Dam Safety, became active in mandating that unsafe dams under their jurisdiction be repaired or breached. The Authority received a long-term dam rehabilitation program to satisfy the mandate for Dams No. 1 and 3. This case history is a summary of a report by Kline (1992).

Among the original design features for both dams was hand-placed riprap on the upstream and downstream sides of both dams. Stone-lined channels in the right abutments serve as spillways for both structures. Stone-encased, rock-founded, 508-mm- (20-in.-) diam cast-iron pipes make up the outlet works of the dams. These outlet pipes are fitted with vertical 1.6-radian (90-deg) elbows and

screens at the upstream end and stone masonry valve houses at the downstream end. Two 508-mm (20-in.) serial valves with blow-off lines are contained in this house and operate as drains for the reservoirs.

Because no pipes directly connect the reservoirs to the distribution system, water releases through the outlet pipes can supplement the withdraws at the system's intake pond located downstream of Dam No. 1. Releases from Dam No. 3 travel to the reservoir of Dam No. 1, thus entering directly into the intake point. Water enters the Authority's system through a supply line through the intake pond's embankment.

As a result of age and lack of maintenance, the outlet works facilities at both dams were in need of repair. Seepage observed near the outlet works at each dam raised the question as to whether the leakage came from the outlet pipe or through the embankment. Piping had been noted in the embankment material at Dam No. 1. Neither outlet works had a way of closing its outlet pipe. Remedial measures to remedy these deficiencies were undertaken.

The ability to isolate flow from an earthen embankment was a safety feature adopted by the state's Division of Dam Safety. By isolating flow from the reservoir to the outlet pipe, upstream closure can prevent further damage to an earthen embankment should a serious leak develop through the joints or a rupture of the pipe. In order to isolate flow from the earthen structures, aid in outlet pipe inspection, and prevent reservoir storage loss in the failure of related dam mechanisms, a method for the upstream closure of the outlet pipes was pursued. Alternatives considered included having a diver install a steel plate blind flange (this was the least costly, but most awkward and hazardous alternative--concerns included loss of flange, installation ease, and diver safety); installing a submerged valve that would be operated by stem installed on upstream bank (convenient top of dam operation--concerns included ice/frost damage leading to failure of operating stem); installing a gate tower operating platform (connection with gate operator stand and immersed sluice gate/valve--concerns included adequate foundation, cost, and necessity); and constructing a submerged intake chamber with a valve that would be operated by a diver (cost effective and safe with long-term operability). This design alternative was chosen for the rehabilitation.

The submerged intake chamber (Figure 155) allowed for various foundation conditions and diver safety in valve operation. The intakes consist of a cast-in-place concrete chamber housing two valves in series mounted at the upstream end of the outlet pipe. The actuators for the valves were specially fitted with stainless steel parts to resist corrosion. The second valve was a backup for the first valve in case it failed to operate. A flap gate mounted on the pipe entrance would also meet this purpose. Aluminum floor grating placed on the cast-in-place valve housing served as an intake screen and working platform for the operator. In the event of an emergency, a diver could be onsite for valve operation within a day. Downstream valves controlled routine reservoir release.

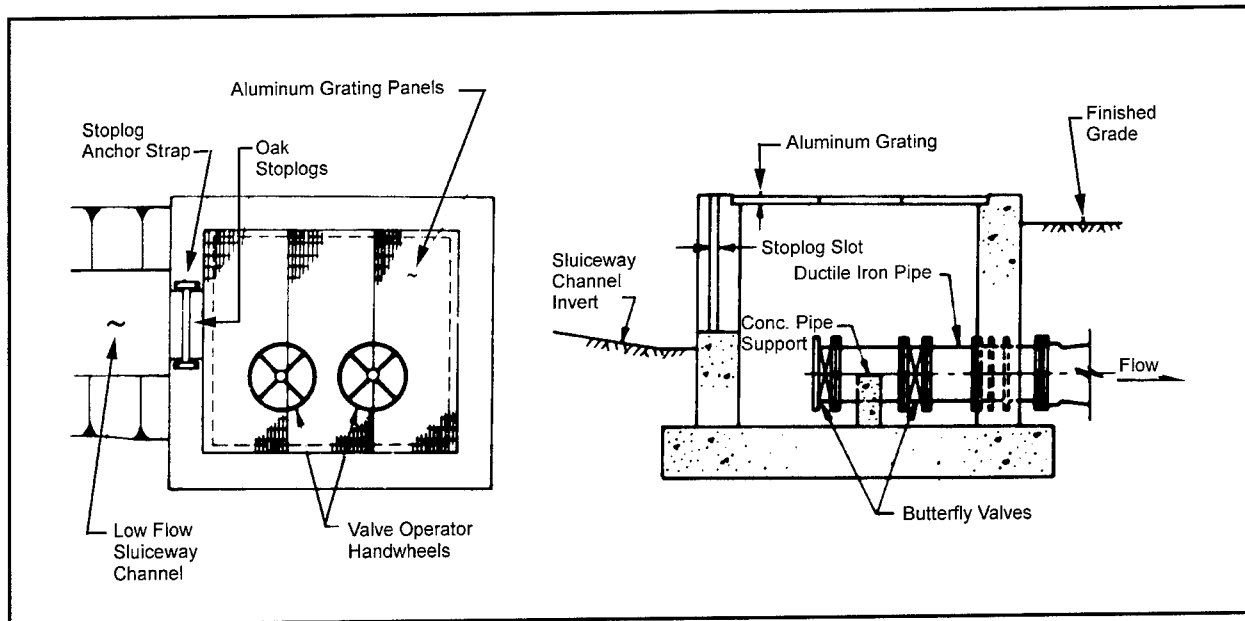

Figure 155. Plan for submerged intake structure at Waste House Dam No. 1 (from Kline 1992)

Because of the age and the infrequency of their use, the existing outlet pipes of both structures were cleaned and slip-lined with a polyethylene plastic pipe. A high-pressure rotary water jet was used to clean the pipes before the linings were installed. A butt fusion heat welding process joined the polyethylene plastic pipe liner onsite. The manufacturer claims this procedure ensures joint strength greater than that of the pipe material.

Rehabilitation costs totalled only 10 percent of the original construction cost (Kline 1992).

### Williams Bridge Dam

Williams Bridge Dam, which is owned by Pennsylvania Gas and Water Company, impounds a supply reservoir with a 1.1-billion  $\ell$  (300-million-gal) capacity. The reservoir supplies 1.6 billion  $\ell$  (3.5 million gal) of water per day to Scranton and surrounding communities. The earth embankment dam, completed in 1893, has a maximum height of 16.8 m (55 ft) and a length of 198 m (650 ft) with upstream and downstream slopes of 3-1/2H:1V and 3H:1V, respectively. The dam has a combination masonry and concrete core wall that rises approximately 0.9 m (3 ft) above the top of the embankment. Originally, the dam had a two-stage spillway section. A 17-m- (56-ft-) long, 1.5-m- (5-ft-) wide broad-crested weir served as the primary spillway; the second-stage spillway, 0.3 m (1 ft) above normal pool, was a 31.4-m- (103-ft-) long masonry wall with 1.3 m (4.2 ft) of freeboard above the top of the dam.

Hydrologic calculations based on PMF criteria established by the USACE and the Pennsylvania Department of Environmental Resources determined that

Williams Bridge Dam could safely pass only 31 percent of its calculated PMF. The dam was rated high hazard because of this deficiency and because of its location: it is approximately 914 m (1000 yd) upstream of Lake Scranton Dam and could cause loss of life and property downstream of Lake Scranton Dam should it fail. Boyle (1987) described the modifications made to Williams Bridge Dam in 1985 to ensure its structural integrity in the event of a PMF. This case history is a summary of his report.

Calculations indicated an additional spillway capacity of 305 cms (10,750 cfs) would be required for the dam to pass the PMF. The design for the modifications included a new 68.6-m- (225-ft-) long concrete ogee spillway along the west shore of the existing reservoir at normal pool elevation (existing low-stage spillway) and a side channel spillway chute. The ogee-shaped spillway was chosen because it would maximize flow for the length of the weir. The side-channel spillway chute was constructed to carry the overflow from the new spillway back to the downstream channel.

The side channel spillway chute was constructed first. The design consists of an approximately 15-m- (50-ft-) wide upper stilling basin that overflows into a 61-m- (200-ft-) long chute that flows into an approximately 7.6-m- (25-ft-) wide lower stilling basin. Flow through the channel drops a vertical distance of 14.6 m (48 ft). A 1.5-m- (5-ft-) high concrete gravity weir was constructed to create the lower stilling basin, which initiates a hydraulic jump to dissipate flow from the spillway chute. A 0.3-m- (1-ft-) wide slot in the center of the small gravity weir allows low flow to return to the downstream channel. Construction began with the excavation of 8,410 cu m (11,000 cu yd) of overburden and 19,100 cu m (25,000 cu yd) of rock. Controlled blasting was used to help with excavation of the rock. As a result, some minor cracking occurred in the existing concrete retaining wall near the dam; however, this wall was replaced with a new reinforced concrete wall as a part of the rehabilitation project.

When excavation was completed, the reservoir was lowered approximately 3.7 m (12 ft) below normal pool elevation 1,360.6; the exposed bedrock for the new spillway averaged elevation 1,355. In September 1985, Hurricane Gloria caused excessive flooding at the dam site. It is believed flooding would have overtopped the earth embankment core wall if excavation of the side spillway chute had not been complete.

The area was cleaned after the flooding, and construction of the concrete ogee spillway was begun. The structure consists of nine 7.6-m- (25-ft-) long bays. Concrete specifications included a compressive strength of 20.7 MPa (3,000 psi), a maximum aggregate size of 6.4 mm (2-1/2 in.), 218 kg (480 lb) of Type II cement per cubic yard, and a w/c 0.48. To ensure uniform foundation bearing, workers grouted the foundation for the side channel spillway where necessary and installed ten 310-kN (70-kip) rock anchors across a fracture zone in the foundation. When the new spillway was completed within 0.6 m (2 ft) of the maximum elevation, steel cables installed at the outside quarter points of each bay were posttensioned to produce a working load of 620 kN (140 kips) of stabilizing force per bay.

The new spillway resulted in acceptable freeboard requirements for the existing earth embankment. However, the concrete masonry core wall had to be injected with grout to eliminate seepage along the downstream slope that could have undermined the stability of the embankment. Primary and secondary injection holes were drilled on 6-m (20-ft) spacings from the top of the core wall; tertiary holes were drilled where necessary. A total of 25.6 Mg (28 tons) of cement was injected into the core wall. The grouting program noticeably reduced the seepage exiting on the downstream slope. In addition to the grouting program, a 0.3-m- (1-ft-) thick layer of filter material placed along the toe of the dam and covered with shot rock from the side channel excavation, stabilized the remainder of the earth embankment.

The existing spillway sections were stabilized with twelve 2,500-kN (560-kip) posttensioned rock anchors so these sections would meet stability criteria for the PMF and ice loading conditions. Before the posttensioning work was begun, cement grout was injected into the foundation rock to consolidate it and to reduce seepage through the structure. Then 152-mm- (6-in.-) diam holes were drilled from the top of the dam to depths as great as 15.2 m (50 ft) into the underlying bedrock. Steel cables consisting of 7-wire, high-strength steel strands were lowered into the holes and grouted into the bedrock zone to create a lower anchorage. A hydraulic ram, locked off at the required working load, was used to stress the tendons. The stressed tendons were then grouted for the entire length to provide corrosion protection.

Construction work at the site was completed in January 1986 at a cost of \$1,800,000.

### **Wissota Dam**

The Wissota Hydroelectric Project is located on the Chippewa River about 5 km (3 miles) upstream of Chippewa Falls, Wisconsin. The project, completed in 1917, is owned by Northern States Power (NSP) Company. The overall project includes a powerhouse which contains six vertical Francis turbine generator units, two sections of slab and buttress dams, a spillway structure with 13 counterbalanced flap gates, and three embankment sections with concrete core walls. The two sections of slab and buttress dams are located on either side of the powerhouse. The dams impound Lake Wissota, a 69,076,000-cu m (56,000-acre-ft) reservoir.

The original slab and buttress concrete was very lightly reinforced compared to today's standards. The inevitable seepage coupled with the use of nonair-entrained concrete used in construction and severe environmental conditions caused the concrete to deteriorate. In the early 1930s, concrete overlays were placed on parts of the upstream face to strengthen it, and support slabs and beams were placed under parts of the upstream face during repairs completed in 1934 and 1959. Asbestos transit panels were also installed on the downstream face of the dam. Although these repairs extended the life of the project, they did not rehabilitate the structure.

In 1985 the Federal Energy Regulatory Commission (FERC) notified NSP that a firm schedule must be developed to repair or replace the slab and buttress dams. NSP decided to rehabilitate the dams to conform to the FERC requirements and to give the dams an additional 50-year life span. LaMar, Ivarson, and Tenke-White (1991) described the project. This case history is a summary of their report.

Items considered during the selection of rehabilitation alternatives were safety, uninterrupted power generation, maintenance of lake levels, environmental and aesthetic impacts, constructability, cost effectiveness, and life expectancy of the repair. The options selected were to construct a replacement dam for a portion of the south slab and buttress section and to convert the remaining part of this section to a gravity dam by filling the hollow area between the buttresses with mass concrete. The replacement dam for a portion of the south section was selected because the areas between the buttresses in this portion were backfilled. Conversion of this portion to a gravity section would have required excavation of the backfill to place mass concrete between the buttresses. FERC was concerned about the stability of this portion of the dam if the backfill were removed under reservoir loading conditions and would have required lowering the reservoir or building an upstream cofferdam. Neither of these options were desirable, so the decision was made to construct a replacement dam for this portion of the south section. All of the north slab and buttress section was converted to a gravity dam.

Two types of replacement dams were considered: a cellular sheet-pile dam or a sand-fill dam with an impervious cutoff. Also, a matter of consideration was how new and rehabilitated structures would be connected. A study indicated a sheet-pile cell would provide the easiest way to connect the two structures. The cell would also provide support for dewatering a small area or for placing tremie concrete. The study also indicated a sand-fill dam would be the most cost effective alternative, but that connecting it to the existing dam would be difficult. The final decision was a combination of the two alternatives (Figure 156).

The 103.6-m- (340-ft-) long sand-fill dam was placed underwater and consolidated by vibratory compaction. A positive cutoff slurry wall deeper than 18 m (60 ft) was constructed within the sand-fill dam. The dam was connected to a 17-m- (56-ft-) diam sheet-pile cell filled with concrete and sand. Perpendicular to the sheet-pile cell, a tremie-placed concrete dam connects the replacement dam to the existing face slab.

To strengthen the existing slab and buttress dam where it interfaces the new dam to support the concrete that would be placed against it, workers placed mass concrete between the buttresses behind the face slab, thus converting it to a gravity dam. This method was acceptable to the FERC because no significant volume of sand-fill removal was required at this location.

Two areas of concern for converting the slab and buttress portion to a gravity structure were good bond of the mass concrete to the foundation rock and control of temperature in the mass concrete during placement. The rough surface of the

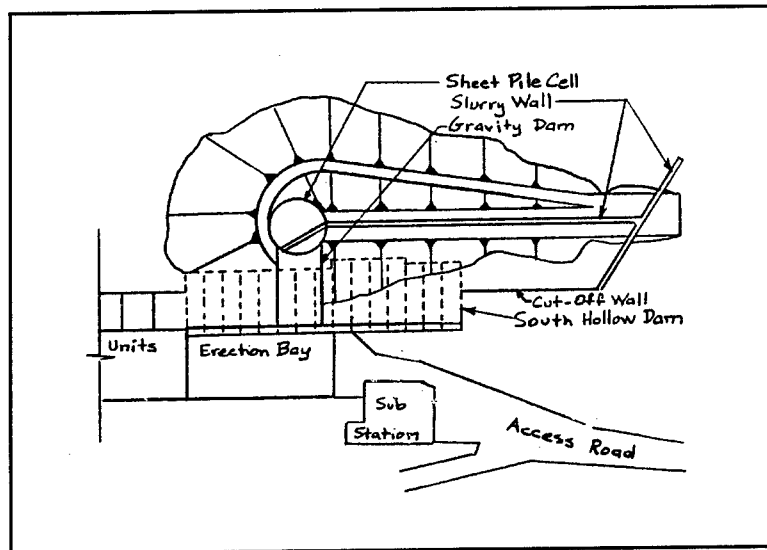

Figure 156. Plan for replacement of South dam at Wissota Hydroelectric Project (from LaMar, Iverson, and Tonke-White 1991)

foundation granite made cleanup very difficult. Workers used shovels, hand tools, water, and vacuums to clean the surface to ensure good bond.

Construction began in the fall of 1988, and the contractor began placing the mass concrete during the cold winter months, thus eliminating the need for special cooling during concrete placement and curing. The remainder of the mass concrete was placed during the winter of 1989, and the tremie concrete was placed in the sheet-pile cell that same winter. At placement, the concrete mixture had a temperature of 7 to 10 °C (45 to 50 °F). The contractor could place 18-m- (6-ft-) high lifts every 3 days or 3-m- (10-ft-) high lifts every 7 days. Thermocouple wires embedded in the concrete monitored the temperature. The highest temperature recorded in the center of the mass was 45 °C (113 °F). Within 60 days after placement was completed, the temperature had decreased to about 21 °C (70 °F).

After the tremie concrete in the cell had set, the cell was filled with sand, and then the “Z” sheet piles for the gravity dam were installed. The gravity dam extends from the powerhouse face slab to the sheet-pile cell. Tremie concrete for the gravity dam was placed, and then rock fill for the earth dike was placed from the shoreline to the gravity dam and powerhouse slab. Sand fill was placed between the rock fill and the existing dam to create the dike. A 21.3-m- (70-ft-) long probe with a 100-hp vibroflot was used to compact the sand in the cell and dike.

A backhoe that could reach to a depth of 18.3 m (60 ft) was used to excavate the 0.6-m- (2-ft-) wide slurry wall. The wall was constructed in a continuous operation; after a length of wall had been excavated to bedrock, the contractor placed plastic concrete (PC) to form the wall. The PC was tremied to the top of



the trench and then by chute directly from the concrete truck. The mixture had an unconfined compressive strength of 4 MPa (601 psi) at 28 days. A thinner was used to obtain a slump of 152 to 254 mm (6 to 10 in.).

While drilling through the slurry to perform foundation grouting, workers found numerous voids, many at the interface and joints between PC pours and others at random locations. Jet grouting was used to fill these areas. When the jet grouting was completed, workers finished the foundation grouting.

The entire north slab and buttress section was converted to a gravity dam. Mass concreting took place under the same requirements as the south section. Because of the late construction start for the north section, the mass concrete at this dam was placed during the summer with significant costs for cooling and some additional delay between lift placements.

The rehabilitation provided NSP with a project that will require only minimal maintenance and will last in excess of another 50 years.

To repair head gates, stoplog slots, and trash racks, NSP had to develop a way to seal the entire fore bay of each unit or lower the reservoir to perform the repairs. Work in the head gate area would require a minimum of 4.6-m (15-ft) drawdown of Lake Wissota, which has a normal full-reservoir volume of 69,076,000 cu m (56,000 acre-ft), and the existing stop-log support trusses were too badly deteriorated to be considered. Rather than rent a barge and crane, NSP had an articulated floating bulkhead designed and fabricated for the project. The floating bulkhead was very similar in design to the one used at Snake River Dams. It was installed at the intakes of Lake Wissota hydroplant in 1987 (Figure 157) (Lux and Regner 1991).

The floating bulkhead is constructed of nine caissons, each comprised of three compartments, which are used to float or sink the unit (Figure 158). The caissons are placed in the water and then linked together to form the bulkhead. The floating bulkhead fabricated for Wissota Hydro Project is 11 m (36 ft) square and 0.7 m (27 in.) thick when fully assembled (Figure 159). Because of its buoyancy, only 1,270 kg (2,800 lb) of the 62-Mg (68-ton) mass of the structure rests on the concrete below the headgate. Steel and wooden vertical guides installed on the pier noses are used to align the bulkhead. To sink the unit, the caissons are selectively filled. Water pressure from the lake seals the bulkhead. When repairs are completed, the water-filled compartments of the caissons are emptied, and the unit rises to the surface. The bulkhead has been installed in less than 2 hr and removed within 30 min. The bulkhead cost about \$130,000 (Lux and Regner 1991).

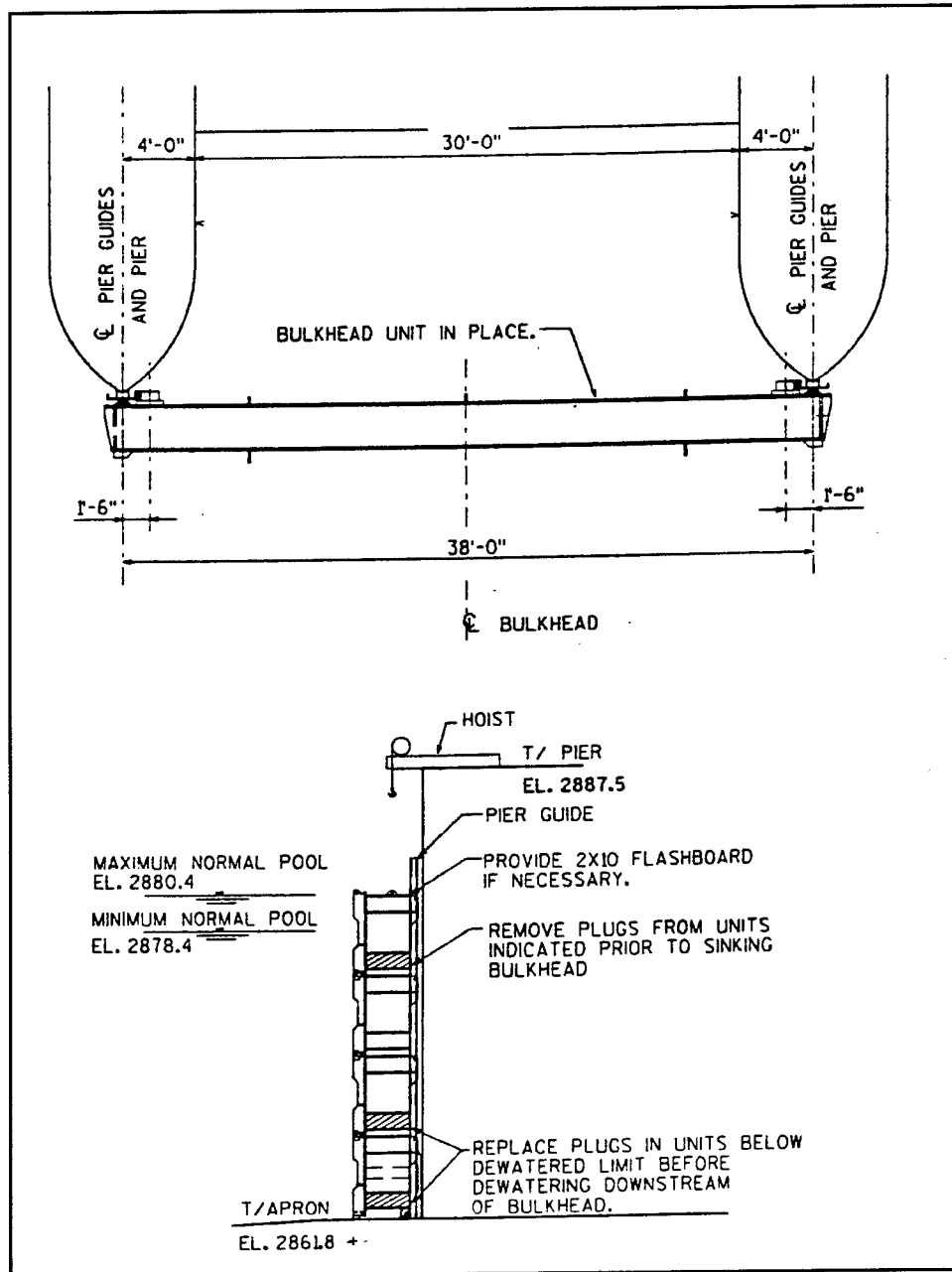

Figure 157. Cross section of design of floating bulkhead, Wissota Hydro Project

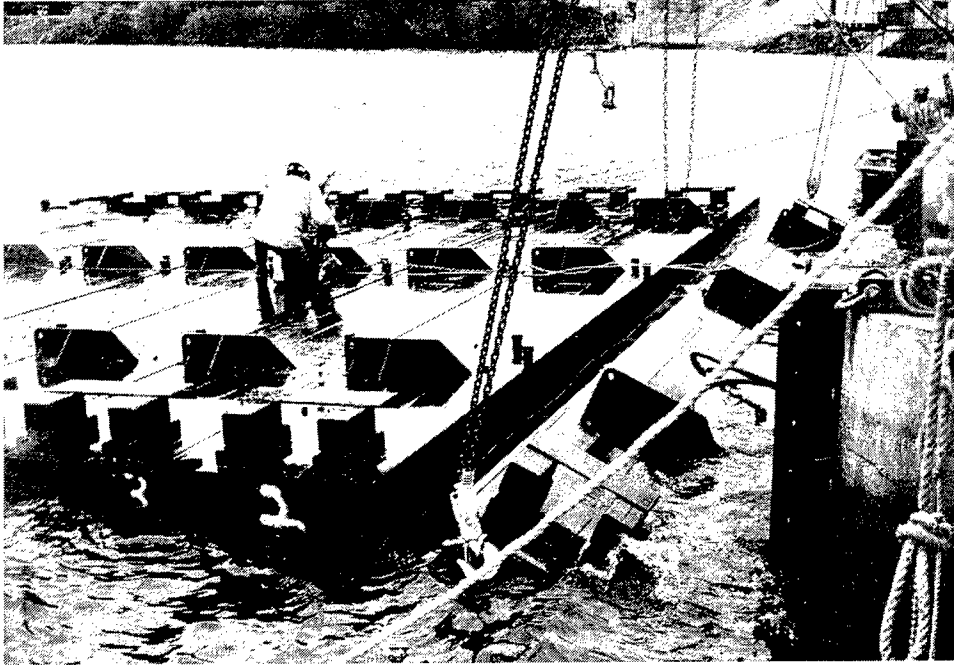

Figure 158. Caissons fill on floating bulkhead, causing bulkhead to sink, Wissota Hydro project

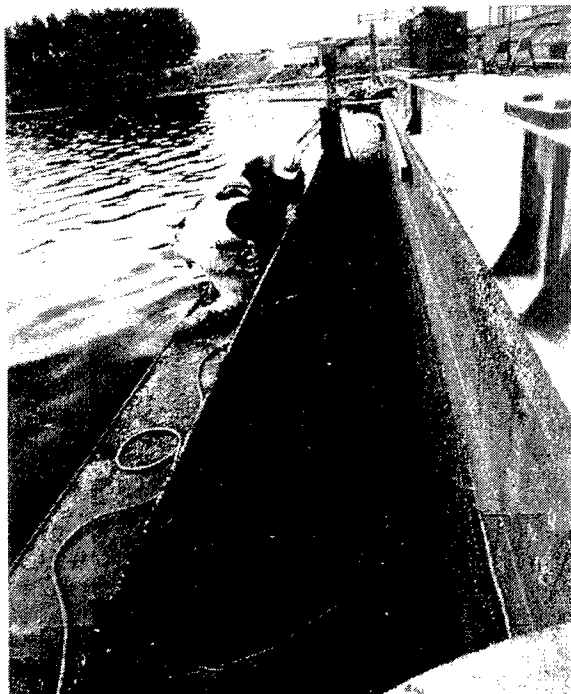

Figure 159. Floating bulkhead used to repair head gates, stop logs, and trash racks at Wissota Hydro Project

## 3 Conclusion

---

Hydraulic structures are a vital part of the infrastructure of this nation as they provide hydropower, water for domestic consumption, irrigation, and recreation, and flood control. Many of the concrete dams at these projects are experiencing deterioration for reasons that include age, weathering, and design flaws. Repairing and rehabilitating these dams is not optional; it is essential. The case histories in this report show that durable, cost-effective materials and methods are available for repairing concrete dams and their appurtenances; many of these repairs can be performed without interruption of the operation of the dam.

As research continues, the variety of available repair materials and the techniques for applying or installing those materials will increase. To ensure a durable, long-term, cost effective repair or rehabilitation, owners, engineers, and contractors should research and carefully evaluate materials and applications for each individual project.

# References

---

- Abraham, T. J., and Sloan, R. C. (1978). "TVA cuts deep slot in dam, ends cracking problem," *Civil Engineering* 48(1), 67-70.
- American Society of Civil Engineers. (1988). "Dam No. 2 - Arkansas River," *Lessons from Dam Incidents, USA-II*, New York.
- American Society for Testing and Materials. (1995). *Annual Book of ASTM Standards*, Philadelphia, PA.
- a. ASTM A 36. "Specifications for carbon structural steel," Vol 01.04.
  - b. ASTM C 33. "Specification for concrete aggregates," Vol 04.02.
  - c. ASTM C 321. "Test method for bond strength of chemical-resistant mortars," Vol 04.05.
  - d. ASTM C 586. "Test method for potential alkali reactivity of carbonate rocks for concrete aggregates (rock cylinder method)," Vol 04.02.
  - e. ASTM D 790. Test methods for flexural properties of unreinforced and reinforced plastics and electrical insulating materials," Vol 08.01.
- Ayers Associates. (1987). "Floating, hinged bulkhead proves flexible, reusable," *Trends*. Eau Claire, WI.
- Balogh, A. (1996). "Project profile: concrete changes the face of Theodore Roosevelt Dam," *Concrete Construction* 41(6), 505-508.
- Barber, M. (1983). "1,100-foot pumping job helps to cure Dam 2 ills," *Construction News*, 28(11), 12-14.
- Barfoot, J. (1989). "Freeze-thaw repairs to Haweswater Dam," *Journal of Concrete Society* 23(10), 44-45.
- Barnes, W. D. (1982a). "Anchoring of spillway monoliths, Alum Creek Lake, Ohio," *Concrete Structures Information Exchange Bulletin, C-82-1*, U.S. Army Engineer Waterways Experiment Station, Vicksburg, MS.

- Barnes, W. D. (1982b). "The high level intake at Sutton Dam, West Virginia," Concrete structures: Repair and rehabilitation, C-82-1, U.S. Army Engineer Waterways Experiment Station, Vicksburg, MS.
- Beall, E. M. (1991). "Super Mario to the rescue," *Southwest Contractor*, 15-21.
- Beckman, T. R., and Hulick, R. M. (1991). "Diamond wire sawing accelerates dam rehabilitation scheme," *Water Power and Dam Construction* 43(7), 25-28.
- Belcher, T. R. (1989). "Glines Canyon Dam concrete restoration and headgate repair using a low cost ROV and divers." *Annual conference proceedings*. Association of State Dam Safety Officials, Lexington, KY, 265-272.
- Bernard, E. M. (1989). "Rx for dam repair," *Civil Engineering* 59(11), 44-46.
- Bianchi, R. H., and Bruce, D. A. (1993). The use of post-tensioned anchorages on the arch portion of Stewart Mountain Dam, Arizona," *Geotechnical Practice in Dam Rehabilitation*, No. 35, American Society of Civil Engineers, New York.
- Biefer, M. (1989). "Taking a slice out of concrete growth," *Canadian Construction Record*, 18-21.
- Boyle, C. W. (1987). "Rehabilitation of Williams Bridge Dam." *American Society of Civil Engineers hydraulic engineering conference*. Williamsburg, VA.
- Brown, H. M., and Kneitz, P. R. (1987). "Repair of New Exchequer Dam," *Water Power and Dam Construction* 39(9), 25-29.
- Bruce, D. A. (1989). "The repair of large concrete structures by epoxy resin bonding," *The REMR Bulletin* 6(4), U.S. Army Engineer Waterways Experiment Station, Vicksburg, MS.
- Bruce, D. A., and Clark, J. H. (1989). "The stabilization of Shepaug Dam, CT, using high prestressed rock anchors." *Annual conference proceedings*. Association of State Dam Safety Officials, Lexington, KY, 136-143.
- Bruce, D. A., Fielder, W. R., and Triplett, R. E. (1991). "Anchors in the desert," *Civil Engineering* 59(5), 40-43.
- Burgi, P. H., and Eckley, M. S. (1987). "Repairs of Glenn Canyon Dam," *Concrete International* 9(3), 24-31.4,31
- Bruce, D. S., and DePorcellinis, P. (1991). "Sealing cracks in concrete dams to provide structural stability," *Hydro Review* 10(4), 116-124.

- Carter, P. (1990). "The upgrading of dams in New South Wales," *Water Power and Dam Construction* 42(5), 19-22.
- Civil Engineering*. (1982). "Olmos Dam modifications," 52(6), 54-55.
- Coghlan, G. T., and Vanderpoel, A. (1980). "Vesuvius Dam Spillway: A case history of concrete performance, failure, and repair," *Concrete International* 2(5), 42-44.
- Concrete Construction*. (1994). "Dam reconstruction uses integral-loop waterstop," 39(6), 523.
- Construction News*. (1992). "Corps finds solution in sinking barges," 59(13), 8-9.
- Davis, J. E., and George, J. F. (1985). "Model tests of Little Falls Dam, Potomac River, NY," Summary Report, U.S. Army Engineer Waterways Experiment Station, Vicksburg, MS.
- Denson, R. H. (1989). "Repair of cavitation/erosion damage at Dworkshak Dam." *Annual conference proceedings*. Association of State Dam Safety Officials, 305.
- Doak, S. S. (1988). "Experimental concrete repairs." *Corps of Engineers structural engineering conference*. St. Louis, MO.
- Ellett, Troy. (1991). "Water-activated foam used to seal leaks at Texas Dam," *Hydro Review* 10(1), 98-99.
- ENR. (1978). "Old dam grows behind floating cofferdams," 200(14), 20-21.
- \_\_\_\_\_. (1981). "Arch dam cracks repaired," 207(12), 42.
- \_\_\_\_\_. (1988). "Brakes applied to sliding dam," Brochure reprinted from *Elk*, June 8, *The McGraw-Hill Construction Weekly*, New York.
- Fosroc International, Ltd. (1990). "Fosroc products for dam repairs," *Fosroc Focus*, Birmingham, England.
- Gore, I. W., and Bickley, J. A. (1987). "Big Eddy Dam," *Concrete International* 9(6), 32-38.
- Hammer, J. J., and Buttrey, H. G. (1984). "Chickamauga Dam and Lock." *Corps of Engineers structural engineering conference*. Pittsburgh, PA.
- Harris, B. N., Palma, J. F., and Miller, D. F. (1991). "Underwater repair of concrete based on REMR technical information," *The REMR Bulletin* 8(4), U.S. Army Engineer Waterways Experiment Station, Vicksburg, MS.

- Hassenboehler, T. (1988). "Old River low sill structure, dewatering and repairs to stilling basin and gate rails." *Corps of Engineers structural engineering conference*. St. Louis, MO.
- Hepler, T. E., Drake, D. M. (1995). "Raising Roosevelt Dam: Protection against floods, earthquakes," *Hydro Review* 14(4), 40-48.
- Hensley, P. J., and Hennig, C. C. (1991). "Overtopping protection for A. R. Bowman Dam," *1991 annual conference proceedings*, Association of State Dam Safety Officials, Lexington, KY.
- Hinchliff, D. L., and Houston, K. L. (1984). "Hydraulic design and application of labyrinth spillways." *Fourth annual USCOLD lecture*. Phoenix, AZ.
- Hubler, R. L., Jr. (1984). "Niagara Falls control dam restoration," *Engineering Digest* 30(8), 27-28.
- Hugenberg, Tom. (1987). "Alkali-carbonate rock reaction at Center Hill Dam, Tennessee." SP-100-96, *Concrete durability, Katharine and Bryant Mather international conference*. John M. Scanlon, ed., Vol 2, American Concrete Institute, Detroit, 1883, 1901.
- Hutton, C. C. (1989). "Rehabilitation of Humphreys Dam and Spillway." *Annual conference proceedings*. Association of State Dam Safety Officials, Lexington, KY, 274-279.
- Hydropower and Dams*. (1997). "A review of hydropower and dam projects in North America: Spillway gates to be replaced at Friant Dam," Issue 3, 40.
- Intrusion-Prepakt, Inc. (1986). "Taming a tenacious undertow with Fabricast™ bags," *Spotlight*, Cleveland, OH.
- Kline, R. A., Jr. (1992). "Innovations in outlet works repairs." *Annual conference proceedings*. Association of State Dam Safety Officials, Lexington, KY, 274-279.
- Kneitz, P. R. (1991). "Outlet works modifications at Abiquiu Dam," *Waterpower '91* Vol 3, 1495-1504.
- LaMar, B., Ivarson, W. R., and Tenke-White, K. (1991). "Rehabilitation and replacement of slab and buttress dams at the Wisconsin Hydroelectric Project," *Waterpower '91* Vol 2, 998-1007.
- Lux, F. III, and Regner, E. P. (1991). "Dewatering using a floating bulkhead proves flexible, reusable and cost effective," *Waterpower '91* Vol 2, 1843-1852.
- Malholtra, R. K., Agarwal, M. L., and Bhat, A. P. (1987). "Spillway repairs at Bhakra Dam," *Water Power & Dam Construction* 39(10), 16-21.



- Marold, W. J., Koniarski, C. M., and Bruen, M. P. (1992). "Chemical grouting of a concrete dam," *The REMR Bulletin* 9(2), U.S. Army Engineer Waterways Experiment Station, Vicksburg, MS.
- Mass, G. R., and Meier, J. G. (1980). "Investigation and repair of Hoist Dam," *Concrete International* 2(9), 49-55.
- McDonald, J. E. (1980). "Maintenance and preservation of concrete structures; repair of erosion damaged structures," Technical Report C-87-4, Report 2, U.S. Army Engineer Waterways Experiment Station, Vicksburg, MS.
- \_\_\_\_\_. (1989). "Evaluation of vinyl ester resin for anchor embedment in concretes," Technical Report REMR-CS-20, U.S. Army Engineer Waterways Experiment Station, Vicksburg, MS.
- \_\_\_\_\_. (1990). "Anchor embedment in hardened concrete under submerged conditions," *The REMR Bulletin* 7(3), U.S. Army Engineer Waterways Experiment Station, Vicksburg, MS.
- \_\_\_\_\_. (1993). "Geomembranes for repair of concrete hydraulic structures," *The REMR Bulletin* 10(4), 1-6, U.S. Army Engineer Waterways Experiment Station, Vicksburg, MS.
- \_\_\_\_\_. (1998). "Repairing concrete underwater with geomembrane systems," *Hydro Review* XVII(3), 42-48.
- McDonald, J. E., and Campbell, R. (1985). "The condition of Corps of Engineers' concrete structures," REMR-CS-2, U.S. Army Engineer Waterways Experiment Station, Vicksburg, MS.
- Neeley, B. D., and Wickersham, J. (1989). "Repair of Red Rock Dam," *Concrete International* 11(10), American Concrete Institute, Detroit, MI.
- Nuss, L. K., and Fielder, W. R. (1988). "Proposed posttensioned anchors for Stewart Mountain Dam thin arch structure." *Corps of Engineers Structural Engineering Conference*. Pittsburgh, PA.
- Oceaneering International, Inc. (1991). "Underwater placement of bulkhead gates at Abiquiu Dam, New Mexico," Falls Church, VA.
- Onken, S. C. (1998). "Installing an underwater geomembrane at Lost Creek Dam," *Hydro Review* XVII(3), 34-38.
- Parrett, N. (1986). "New approaches to rehabbing old dams," *Civil Engineering* 56(6), American Society of Engineers, New York.
- Quint, R., and Fielder, W. R. (1989). "Dams reborn," *Civil Engineering* 59(5), 44-47.

- Rosenbaum, D. B. (1991). "Lake tap proves difficult," *ENR* 226(13), 24-25.
- Rutledge, J. (1989). "Increasing spillway capacity to allow passage of the PMF at Morris Sheppard Dam." *Annual conference proceedings*. Association of State Dam Safety Officials, Lexington, KY, 375-385.
- Sharma, R. P., and Sarkaria, G. S. (1985). "Rapid filling of reservoirs," *Waterpower '85* Vol 2, 1411.
- Sims, G. P., and Evans, D. E. (1988). "Alkali-silica reaction: Kamburu spillway, Kenya, case history," Part 1 Design and Construction, Vol 84. *Proceedings, The Institution of Civil Engineers*, Vol 84, The Institution of Civil Engineers, UK.
- Smoak, W. G. (1990). "Field applications of concrete surface impregnation." *Proceedings International Conference on protection of concrete held at the University of Dundee*. Scotland, UK.
- \_\_\_\_\_. (1991). "Crack repairs to Upper Stillwater Dam," *Concrete International* 13(2), 33-36.
- Sondergard, Kenneth B. (1991a). "Effective underwater joint sealing at Chief Joseph Dam," *The REMR Bulletin* 8(2), U.S. Army Engineer Waterways Experiment Station, Vicksburg, MS.
- \_\_\_\_\_. (1991b). "Remedial joint sealing at Chief Joseph Dam," *Concrete International* 13(6), 39-42.
- Standig, K. F. (1984). "Rehabilitation of the Delta Dam," *Water Power & Dam Construction* 36(12), 21-24.
- Stowe, R. L., and Thornton, H. T., Jr. (1981). "Condition survey repair and rehabilitation Lock and Dam No. 24, Mississippi River," Miscellaneous Paper SL-81-21, U.S. Army Engineer Waterways Experiment Station, Vicksburg, MS.
- Sumner, A. C., Nash, M. F., and Haag, T. W. (1991). "Rehabilitation of the dams at the Crescent and Vischer Ferry Hydroelectric Projects," *Waterpower '91*, Denver, CO.
- Timblin, L. O., Jr., Grey, P. G., Starbuck, J. E., and Frobel, R. K. (1984). "Flexible membrane emergency spillway." *Fourth annual USCOLD lecture*. Bureau of Reclamation, Phoenix, AZ.
- Thompson, R. A., and Waters, R. H. (1989). "Restoration of a buttress dam." *Annual conference proceedings*. Association of State Dam Safety Officials, Lexington, KY, 274-279.
- TVA Today*. (1976). "Fixing the crack in Fontana," 7(2), 2-3.

- U.S. Army Engineer District, Huntington. (1984). "Sutton Lake, Elk River, West Virginia, concrete dam," Periodic inspection report no. 4, Huntington, WV.
- \_\_\_\_\_. (1989). "Sutton Lake, Elk River, West Virginia, concrete dam," Periodic inspection report no. 5, Huntington, WV.
- \_\_\_\_\_. (1990a). "Delaware Lake, Olentangy River, Ohio: Dam, Outletworks, and Waldo Levee," Periodic inspection report no. 5, Huntington, WV.
- \_\_\_\_\_. (1990b). "Mohawk Dam, Walhonding River, Ohio, Dam, Outlet Works and Spillway," Periodic inspection report no. 5, Huntington, WV.
- \_\_\_\_\_. (1990c). "Tom Jenkins Dam, East Branch of Sunday Creek, Ohio, Dam, Outlet Works and Spillway," Periodic inspection report no. 5, Huntington, WV.
- \_\_\_\_\_. (1993). "R. D. Bailey Lake, Guyandotte River, West Virginia, Dam, Outlet Works and Spillway," Periodic inspection report no. 10, Huntington, WV.
- U.S. Army Engineer District, Little Rock. (1990). "Norfork Dam and Power Plant, Norfork River, Arkansas: Dam and Power Plant," Periodic inspection report no. 8, Little Rock, AR.
- \_\_\_\_\_. (1994). "Clearwater Lake Project, Black River, Missouri, Dam and Outlet Works," Periodic inspection report no. 7, Little Rock, AR.
- \_\_\_\_\_. (1997a). "DeQueen Lake Project, Rolling Fork River, Arkansas," Periodic inspection report no. 8, Little Rock, AR.
- \_\_\_\_\_. (1997b). "Gillham Lake Project, Cossatot River, Arkansas," Periodic inspection report no. 8, Little Rock, AR.
- U.S. Army Engineer District, New Orleans. (1988). "Old River Sill Control Structures, 1987 stilling basin and gate rail inspection and repairs," Periodic inspection report no. 9, New Orleans, LA.
- \_\_\_\_\_. (1996). "Old River Project, Low Sill Control Structure," Periodic inspection report no. 11, New Orleans, LA.
- U.S. Army Engineer, District, Pittsburgh. (1985). "Tygart Dam," Fourth periodic inspection report, Pittsburgh, PA.
- \_\_\_\_\_. (1989a). "Point Marion Lock and Dam, Monongahela River," Fifth periodic inspection report, Pittsburgh, PA.

U.S. Army Engineer, District, Pittsburgh. (1989b). "Stonewall Jackson Dam," Second periodic inspection report, Pittsburgh, PA.

\_\_\_\_\_. (1990a). "Loyalhanna Dam," Fifth periodic inspection report, Pittsburgh, PA.

\_\_\_\_\_. (1990b). "Tygart Dam, West Virginia," Fifth periodic inspection report, Pittsburgh, PA.

\_\_\_\_\_. (1992). "Stonewall Jackson Dam," Fifth periodic inspection report, Pittsburgh, PA.

\_\_\_\_\_. (1994). "Point Marion Lock and Dam, Monongahela River," Seventh periodic inspection report, Pittsburgh, PA.

\_\_\_\_\_. (1995a). "Stonewall Jackson Dam," Seventh periodic inspection report, Pittsburgh, PA.

\_\_\_\_\_. (1995b). "Tygart Dam," Sixth periodic inspection report, Pittsburgh, PA.

U.S. Army Engineer District, Rock Island. (1990). "Illinois Waterway, Dresden Island Lock and Dam, Morris, Illinois, periodic inspection and continuing evaluation of completed Civil Works Structures," Periodic inspection report no. 5, Rock Island, IL.

\_\_\_\_\_. (1991a). "Illinois Waterway, Illinois, La Grange Lock and Dam, Versailles, Illinois, Periodic inspection report no. 5, Rock Island, IL.

\_\_\_\_\_. (1991b). "Nine-foot channel project, Mississippi River, Canton, Missouri, Lock and Dam No. 20," Periodic inspection report no. 5, Rock Island, IL.

\_\_\_\_\_. (1991c). "Illinois Waterway, Illinois, Peoria Lock and Dam, Peoria, Illinois," Periodic inspection report no. 5, Rock Island, IL.

\_\_\_\_\_. (1992). "Illinois Waterway, Illinois, Brandon Road Lock and Dam, Joilet, Illinois," Periodic inspection report no. 6, Rock Island, IL.

\_\_\_\_\_. (1995). "Illinois Waterway, Dresden Island Lock and Dam, Morris, Illinois, Periodic inspection and continuing evaluation of completed Civil Works Structures," Periodic inspection report no. 6, Rock Island, IL.

U.S. Army Engineer District, Rock Island. (1996). "Nine-foot channel project, Mississippi River, Canton, Missouri, Lock and Dam No. 20," Periodic inspection report no. 6, Binder 1 of 2, Rock Island, IL.

- U.S. Army Engineer District, St. Louis. (1993). "Major Rehabilitation Report: Lock and Dam No. 24, Mississippi River," Major rehabilitation project, St. Louis, MO.
- \_\_\_\_\_. (1997). "Lock and Dam No. 24, Mississippi River, Clarksville, Missouri, Lock and Dam, Storage Yard and Overflow Dike," Periodic inspection report no. 10, Rock Island, IL.
- U.S. Army Engineer District, St. Paul. (1991). "Lock and Dam 1 and Crib Wall, Mississippi River, Minnesota," Periodic inspection report no. 3 and Crib Wall periodic inspection report no. 4, St. Paul, MN.
- U.S. Engineer District, Walla Walla. (1983). Lucky Peak Lake, Idaho: Flip bucket modification," Design Memorandum No. 12, Walla Walla, WA.
- \_\_\_\_\_. (1989). "Lucky Peake Lake, Boise River, Idaho, Dam Safety Assurance Program," Periodic inspection report no. 7, Walla Walla, WA.
- \_\_\_\_\_. (1987). "Dworkshak Dam and Reservoir, North Fork Clearwater River, Idaho, Dam Safety Assurance Program," Periodic inspection report no. 11, Walla Walla, WA.
- U.S. Army Engineer District, Wilmington. (1966). "Philpot Lake Dam and Powerhouse, Roanoke River Basin, Virginia," Periodic inspection report no. 1, Wilmington, NC.
- \_\_\_\_\_. (1988). "Philpott Lake Dam and Powerhouse, Roanoke River Basin, Virginia," Periodic inspection report no. 5, Wilmington, NC.
- \_\_\_\_\_. (1993). "Philpott Lake Dam and Powerhouse, Roanoke River Basin, Virginia," Periodic inspection report no. 6, Wilmington, NC.
- Water Power & Dam Construction*. (1989). "Concrete repairs at Haweswater Dam, UK," 41(8), 54-56.
- \_\_\_\_\_. (1990). "Permanent remedial measures to proceed soon at Daniel Johnson Dam," 42(2), 3.
- \_\_\_\_\_. (1991a). "Permeable formwork liner for German dam repair," 43(10), 73-74.
- \_\_\_\_\_. (1991b). "Ageing of dams and remedial measures," Report of the 17th ICOLD Congress.
- Webster, R. P., Kukacka, L. E., and Elling, D. (1989). "In situ repair of deteriorated concrete in hydraulic structures: a field study," Technical Report REMR-CS-21, U.S. Army Engineer Waterways Experiment Station, Vicksburg, MS.

Wehrley, D. R. (1988). "Illinois Waterway Marseilles Dam major rehabilitation." *Corps of Engineers Structural Engineering Conference*. St. Louis, MO.

Zeccolo, S. J. (1992). "Stillwater Dam rehabilitation project." *Annual conference proceedings*. Association of State Dam Safety Officials, Lexington, KY.

# REPORT DOCUMENTATION PAGE

*Form Approved*  
*OMB No. 0704-0188*

Public reporting burden for this collection of information is estimated to average 1 hour per response, including the time for reviewing instructions, searching existing data sources, gathering and maintaining the data needed, and completing and reviewing the collection of information. Send comments regarding this burden estimate or any other aspect of this collection of information, including suggestions for reducing this burden, to Washington Headquarters Services, Directorate for Information Operations and Reports, 1215 Jefferson Davis Highway, Suite 1204, Arlington, VA 22202-4302, and to the Office of Management and Budget, Paperwork Reduction Project (0704-0188), Washington, DC 20503.

|   |   |  |  |  |
|---|---|--|--|--|
| <b>1. AGENCY USE ONLY (Leave blank)</b>   |   | <b>2. REPORT DATE</b><br>September 1999        | <b>3. REPORT TYPE AND DATES COVERED</b><br>Final report                        |  |
| <b>4. TITLE AND SUBTITLE</b><br>Repair and Rehabilitation of Dams: Case Studies   |   |  | <b>5. FUNDING NUMBERS</b>  |  |
| <b>6. AUTHOR(S)</b><br>James E. McDonald, Nancy F. Curtis   |   |  |  |  |
| <b>7. PERFORMING ORGANIZATION NAME(S) AND ADDRESS(ES)</b><br>U.S. Army Engineer Research and Development Center<br>Waterways Experiment Station<br>3909 Halls Ferry Road, Vicksburg, MS 39180-6199  |   |  | <b>8. PERFORMING ORGANIZATION REPORT NUMBER</b><br>Technical Report REMR-CS-63 |  |
| <b>9. SPONSORING/MONITORING AGENCY NAME(S) AND ADDRESS(ES)</b><br>U.S. Army Corps of Engineers<br>Washington, DC 20314-1000   |   |  | <b>10. SPONSORING/MONITORING AGENCY REPORT NUMBER</b>                          |  |
| <b>11. SUPPLEMENTARY NOTES</b>  |   |  |  |  |
| <b>12a. DISTRIBUTION/AVAILABILITY STATEMENT</b><br>Approved for public release; distribution is unlimited.  |   |  | <b>12b. DISTRIBUTION CODE</b>  |  |
| <b>13. ABSTRACT (Maximum 200 words)</b><br><br>This study was conducted to identify methods that have been used in the repair and rehabilitation of concrete dams. Information was obtained through literary searches, discussions with project personnel, and visits to project sites. Each case history includes a background of the project, the deficiency that necessitated repair or rehabilitation, and descriptions of materials and methods used in the repair or rehabilitation. When available, the cost of the repair project and the performance of the repair to date have been included. Case histories included in this report cover a range of deficiencies in concrete structures, including cracking, spalling, erosion, leakage, inadequate PMF capacity, expansion resulting from alkali-aggregate reaction, instability, and insufficient storage capacity. |   |  |  |  |
| <b>14. SUBJECT TERMS</b>  |   |  | <b>15. NUMBER OF PAGES</b>   |  |
| Aeration slots  | Epoxy injection   | Super-plasticizer concrete                     | 265  |  |
| Cellular cofferdam  | Flexible membrane lining  | Vinyl resin epoxy                              | <b>16. PRICE CODE</b>  |  |
| Dewatering analysis   | Geomembrane system  | Water-activated foam grout                     |  |  |
| Diamond-wire cutting  | Labyrinth spillway  |  |  |  |
| <b>17. SECURITY CLASSIFICATION OF REPORT</b><br>UNCLASSIFIED  | <b>18. SECURITY CLASSIFICATION OF THIS PAGE</b><br>UNCLASSIFIED | <b>19. SECURITY CLASSIFICATION OF ABSTRACT</b> | <b>20. LIMITATION OF ABSTRACT</b>  |  |