



US Army Corps
of Engineers

Construction Engineering
Research Laboratory

CERL Technical Report 99/77
August 1999

Application of Visualization in Structural Engineering Design

Blessing Adeoye
Victor Aviles
Beth Brucker

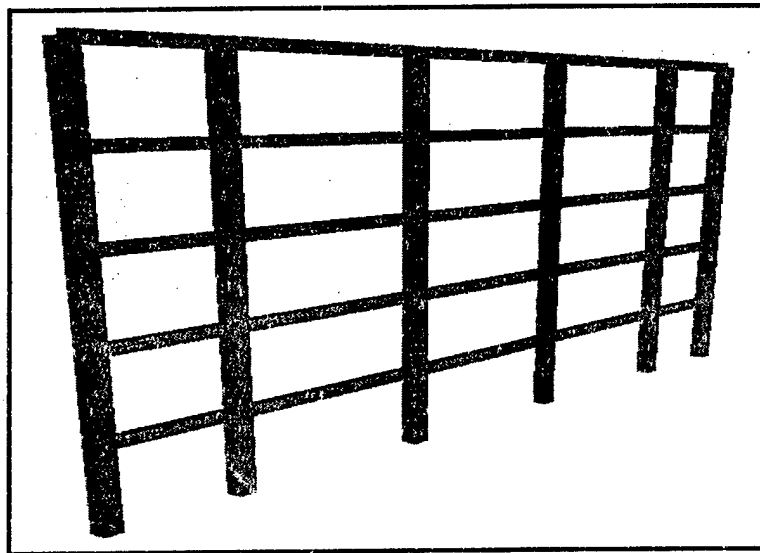

The addition of improved visualization capabilities to engineering design applications can help engineers visualize problems better, analyze problems more accurately, and find better solutions. Applications that involve visualization commonly use the visual modes of volume visualization, color shading, contour lines, animation, and surface representation techniques. However, little research has been done concerning the application of visual modes in structural engineering design analysis. This basic research study investigated how different visual modes influence engineers' decisions in solving problems, and attempted to determine significant differences between the effectiveness of various visual modes.

19991220 021

The contents of this report are not to be used for advertising, publication, or promotional purposes. Citation of trade names does not constitute an official endorsement or approval of the use of such commercial products. The findings of this report are not to be construed as an official Department of the Army position, unless so designated by other authorized documents.

DESTROY THIS REPORT WHEN IT IS NO LONGER NEEDED

DO NOT RETURN IT TO THE ORIGINATOR



**US Army Corps
of Engineers**

Construction Engineering
Research Laboratory

CERL Technical Report 99/77
August 1999

Application of Visualization in Structural Engineering Design

Blessing Adeoye
Victor Aviles
Beth Brucker

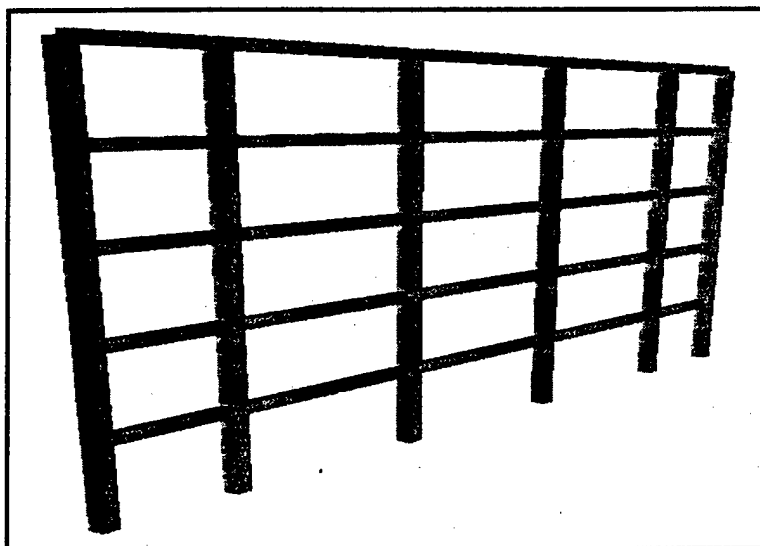

The addition of improved visualization capabilities to engineering design applications can help engineers visualize problems better, analyze problems more accurately, and find better solutions. Applications that involve visualization commonly use the visual modes of volume visualization, color shading, contour lines, animation, and surface representation techniques. However, little research has been done concerning the application of visual modes in structural engineering design analysis. This basic research study investigated how different visual modes influence engineers' decisions in solving problems, and attempted to determine significant differences between the effectiveness of various visual modes.

Foreword

This study was conducted for Headquarters, U.S. Army Corps of Engineers (HQUSACE) under Project 4A162720AT23, "Basic Research in Military Construction," Work Unit EC8, "Advanced Visualization."

The work was performed by the Engineering Processes Branch (CF-N), of the Facilities Division (CF), Construction Engineering Research Laboratory (CERL). The CERL Principal Investigator was Beth Brucker. Michael Case is Chief, CECER-CF-N, and L. Michael Golish is Operations Chief, CECER-CF. The technical editor was William J. Wolfe, Information Technology Laboratory.

The Director of CERL is Dr. Michael J. O'Connor.

Contents

Foreword	2
1 Introduction	7
Background.....	7
Objectives.....	8
Significance of the Problem.....	9
Approach.....	9
Scope.....	9
2 Literature Review	10
Research Design.....	11
Population.....	11
Instrumentation.....	12
Selected Modes in this Study.....	12
<i>3D Structure with Shear Wall and Roof Slab (Figures 1, 2, and 3)</i>	12
<i>Plane Frame (Figures 4, 5, 6, 7, 8, and 9)</i>	12
<i>Flange-Center Plate Connection (Figure 10)</i>	13
<i>Detail Connection (Figure 11)</i>	13
<i>Wall Section (Figure 12)</i>	13
<i>Cantilever Beam (Figure 13)</i>	13
Data Collection.....	20
Data Analysis.....	20
<i>Descriptive Analysis</i>	20
<i>Content Analysis</i>	24
Discussion.....	25
<i>2D Line Drawings</i>	26
<i>3D Colored Graphics (Rendered Graphics)</i>	26
<i>2D and 3D Graphics with Details</i>	26
3 Conclusions and Recommendations	28
References	30
Appendix: Questionnaire	31
CERL DISTRIBUTION	40
REPORT DOCUMENTATION PAGE	41

List of Figures and Tables

Figures

1	3-D structure with shearwall and roof slabs.....	14
2	3-D structure with shearwall and roof slabs.....	14
3	3-D structure with shearwall and roof slabs.....	15
4	Plane frame (1).....	15
5	Plane frame (2).....	16
6	Plane frame (3).....	16
7	Plane frame (4).....	17
8	Plane frame (5).....	17
9	Plane frame (6).....	18
10	Flange-centerplate connection.....	18
11	Detailed connection.....	19
12	Wall section.....	19
13	Cantilever beam.....	20

Tables

1	Frequency of the visual modes that help participants best analyze a clear differentiation between shear walls and slabs.....	21
2	Frequency of the visual mode that helps participants best analyze a clear differentiation between beams and columns.....	21
3	Frequency of the visual mode that gives the participants the best understanding of the supports.....	22
4	Frequency of the form of visual mode that best helps the participants in a problem analysis.....	22
5	Frequency of the visual mode that provides the best overall visualization of structural system.....	22
6	Frequency of the form of visual mode that can be used to provide more detailed information.....	23
7	Frequency of the visual mode that provide the best representation of the material being used.....	23
8	Frequency of whether Figure 13 provides an adequate visual representation of a structural system.....	23
9	A summary of the participants' selections for each figure.....	24

10 Participants explanations why the visual modes they chose in Question 6 best
give a clear differentiation between shear walls and slabs.24

11 Participants' list of type of analyses that they can perform using the figure
chosen in Question 8.25

1 Introduction

Background

The field of scientific visualization had its origin more than 40 years ago when computers began generating more data than most researchers could adequately interpret and analyze within a reasonable period. Scientists began to plot data in crude geometric shapes and graphs, and continually refined this technology to take advantage of greater and greater computing power (File 1997). The role of computational simulations and visualizations in all aspects of engineering has increased greatly in the past years.

Today, large-scale computations are prevalent in all areas of engineering and architecture. Engineering visualization includes the display of behavior, interaction with three-dimensional (3D) models, data presentation, and design optimization (Gallagher 1995). Gallagher indicates that visualization is essential for understanding of multidimensional space. The use of graphics has enhanced the appreciation of 3D objects mapped into two-dimensional (2D) views. Computer generated 3D images have proved to be useful in a variety of applications including data visualization, computer animation, virtual reality, telepresence, and terrain generation. High-tech presentations in these fields require images that generate more quickly, with more details, and in higher resolutions. The ability to generate such images can help support interactions between engineers of different disciplines by helping them select visualization modes best suited to communicating their ideas.

Better visualization capabilities can help in the process of engineering design and analysis. The addition of improved visualization capabilities to many engineering software design applications can help engineers visualize problems better, analyze problems more accurately, and find better solutions. It provides engineers with the information to investigate potential new designs by dynamically altering and tuning design parameters early in the design process. This allows engineers to interactively monitor the progress of new designs and to terminate poor concepts. The end result is shorter design cycles and better-designed products.

In the fields of engineering and architecture, sketches and drawings are essential means of communication to both clients and other designers. Do (1998) conducted an experiment to find the relationship between drawing conventions and their associated tasks. The experiment showed that designers used symbols and configurations to express themselves and deal with design problems. When thinking about allocating objects or spaces with a required dimension, designers jotted down numbers besides the drawing to help themselves reason about size and calculate dimensions. When doing a visual analysis, designers drew sight lines from a viewpoint on a floor plan. This important observation shows that it is possible to associate symbols and spatial arrangements in the drawing with the designer's intention or tasks.

Early in the design process, engineers and designers draw diagrams and sketches to explore ideas and solutions. Engineers and designers are trained to use paper and pencil to develop conceptual designs. They also use diagrams to analyze problems. They draw to develop ideas and also to communicate their thinking through drawings. Visual analysis and design developments are interactive; they involve recording ideas, analyzing problems, recognizing functions and meaning in the drawings, and finding new forms and adapting them into the design. Edwards (1979) argued that drawing is important not merely as a vehicle for communication with others; the act of drawing actually helps designers see and understand the forms they work with. Applications that involve visualization fall into various categories, e.g., design, analysis, and presentation. These types of applications commonly use the visual modes of volume visualization, color shading, contour lines, animation, and surface representation techniques. Visual modes are available in many forms; they are defined as representations of objects. Visualization is widely used in engineering. Properly applied visual modes can help facilitate understanding of design concepts and analysis. However, little research has been done concerning the application of visual modes in structural engineering design analysis. Engineers face many problems (and types of problems) daily; there are a many visual modes are available to represent and address these problems. Selecting visual modes appropriate to a given problem is not always an obvious or easy task. There is a need for a deeper understanding of how visual modes are selected for communication across various disciplines, and how engineers use the cognitive selection process as a tool for analysis.

Objectives

The objectives of this study were to investigate and propose an explanation for how different visual modes influence engineers' decisions in solving problems,

and to determine any significant differences between the effectiveness of various visual modes.

Significance of the Problem

This study is significant in that:

1. The findings of this study may help engineers to better understand how different visual modes influence the cognitive understanding necessary to make decisions.
2. Engineering tool providers will be able to determine significant differences between the effectiveness of visual modes, and provide engineers with the tools that will help them understand problems and communicate ideas easily.

Approach

1. A literature survey was conducted of recent work in the area of two- and three-dimensional modeling, and the use of modal aspects across disciplines.
2. A questionnaire was developed to quantitatively measure the reactions of a defined population of engineers to the use of different modal aspects in structural engineering design.
3. Data was gathered and compiled, and the results were statistically analyzed.
4. Conclusions were drawn regarding the implications of the results of this study for software design, and recommendations were made for further study into the use of visual modes as communication tools that can help engineers solve design problems across disciplines.

Scope

The participants in this study were structural engineering students who may have a limited or a practical experience in visualization and problem analysis. This study was limited to structural engineers that use visualization for analyzing structural design problems.

2 Literature Review

Al-Rasheed (1997) tested the advantages of 3D CAD walk-through models compared to 2D and 3D hard copy drawings in planning construction schedules. A section of an existing co-generator power plant was used as a case study. In this study, 50 experienced U.S. Army Environmental Center (AEC) industry professionals and inexperienced graduate students in the Construction Engineering and Management Program were asked to extract construction activities involving physical elements from one of the three project representations. Each participant was assigned one medium and was instructed to develop a sequence of activities from a complete list. The resulting schedules revealed that those developed using the 3D electronic model had (on average) fewer missing activities, fewer missing relationships, and fewer invalid relationships. Also, they had (on average) shorter duration, fewer critical activities, and smoother resource fluctuations.

Although both experienced and inexperienced planners benefited from the walk-through model, the inexperienced benefited more, especially in developing valid activity relationships. Another 20 participants were presented with a 3D CAD animated schedule and asked to identify safety and overcrowding concerns. There was consistency among the majority of the elements identified. Although the available literature suggested major barriers to implementation of this technology in construction (such as resistance to change in the industry, cost, and extensive training requirements), these were not apparent in this research. The main problem indicated in this study was the lack of technical support for this type of animation application.

Protocol analysis studies have been used to study problem solving in design for decades. Most of these research studies involved the collection of both verbal and visual data. In one of the first protocol studies of design process, Eastman (1968) showed that designers use both words and drawings to deal with problems and their potential solutions. Eastman argues that design is a problem-solving activity performed through sketching. In his study, six subjects performed a simple task of improving a bathroom layout through drawing. Eastman documented the design operations they used, the objects they manipulated, and the control mechanisms they employed.

In a recent study, Suwa and Tversky (1996) videotaped architects sketching to design an art museum. While watching the tape, participants reported what they had been thinking about. Suwa and Tversky looked at the relation between concepts and graphical acts of sketching, and argued that seeing different types of information in sketches drives the refinement of design ideas. The investigators classified the information in the protocols into different categories such as spaces, shapes, things, lights, views, and circulation. Based on this study, they proposed a computational tool that responds to sketches to stimulate design thinking.

Most studies presented in this review dealt with "visualization" in general. Some describe the association of verbal thinking protocols with design drawing. However, none identified the visual modes engineers use in structural engineering design analysis. The studies mainly looked at the verbal descriptions of design problems and solutions, and the cognitive process in design analysis. Little research has been conducted concerning the application of visualization in structural engineering design analysis.

Research Design

This study is a quantitative inquiry. It is exploratory in nature and used a survey methodology. A quantitative approach was chosen because it produces accurate and reliable measurements that permit statistical analysis. The primary reason for conducting quantitative research is to learn how many people in a population have (or share) a particular characteristic or group of characteristics. In this study, the reactions of many users will be measured with a limited set of questions that will facilitate comparison and statistical aggregation of collected data.

Population

A purposive sampling method was used to select participants because the researcher already had a purpose in mind. Usually, there are one or more specific predefined groups in mind. Purposive sampling is useful for this study in order to reach a targeted sample quickly and because sampling for proportionality is not the primary concern. The selected participants were (30) structural engineering students enrolled in a structure class in the summer 1998 at the California Polytechnic State University.

Instrumentation

A prototype of the questionnaire to be used in this study was compiled through a brainstorming session by a team of researchers at the U.S Army Construction Engineering Research Laboratory (CERL). A pilot test was conducted at CERL to test the validity of the survey instrument. The survey was distributed to seven structural engineers, two architects, and one graduate student. Each participant in the pilot study took the survey and provided constructive comments for improvement. The original survey instrument was developed and sent to the participants after the revision.

Selected Modes in this Study

The graphic mode is defined as a representation of an object on a 2D surface, such as a graph, diagram, drawing, or chart. According to Winn (1987), the graphic mode lies in the middle of a "continuum that extends from pictures to words" (p.152) and is characterized by abstraction and exploitation of space. In this study, visual modes are synonymous to graphic modes. The following paragraphs explain the visual modes used in the survey instrument.

3D Structure with Shear Wall and Roof Slab (Figures 1, 2, and 3)

3D structures can produce 3D components using the 2D components created within 2D design. Users can create linear components such as beams and columns and planar components such as walls, floors, slabs, or plates by extruding sections. In some cases, these sections include standard profiles such as channels, tees, angles, squares and rectangles, as well as any user-defined shape. To create a planar element between two lines, designers can use a defined contour, elevation standard, or a 2D-design component. This particular mode was chosen to represent how vertical and horizontal elements are combined to form a typical structure. It is easy to demonstrate visualization using this type of mode because of its shape, form, and volume.

Plane Frame (Figures 4, 5, 6, 7, 8, and 9)

Plane frames are commonly used to represent the behavior of materials when loads are applied, relationships between vertical and horizontal elements, non-linearity due to material behavior, large deformations, and problems at supports. The figures used in this section were randomly selected from a combination of common visual modes for frame analysis. These plane frames were used to address multiple-span beams and columns and plane-frame structures in the elas-

tic range, and include the secondary effects of deflected shapes under a load. Several plane frames (Figures 4 to 9) were chosen to provide engineers more choices of visual modes for decisionmaking.

Flange-Center Plate Connection (Figure 10)

Figure 10 shows how connections between members may be either rigid or hinged. This visual mode was selected because it illustrates a combination of 3D elements, texts, and load application.

Detail Connection (Figure 11)

Detail connections usually include all dimensions, details, clearances, and components. The purpose of this visual mode is to illustrate information presented in two dimensions with detailed information.

Wall Section (Figure 12)

Figure 12 was selected because it consists of elements of a typical wall type. It consists of a wall skeleton and facing panel that may help in visual analysis of wall types.

Cantilever Beam (Figure 13)

There are different types of cantilever beams. Each beam is used for a specific analysis. For example, beams with a concentrated load can represent a concentrated load, which is an idealized simplification of a load the extent of which is very small compared to the length of the beam. Beams with a uniform load can exert equal force along each point of the beam's length. Beams with a triangular load are those in which force varies linearly along the beam's length and is zero at one of the beam's ends. Beams with a parabolic are those in which force varies quadratically along the beam's length and is zero at one of the beam's ends. Figure 13 shows a cantilever beam with a concentrated load, which was chosen at random for purposes of illustration. Engineers will select any of the visual modes based on the type of analyzes to be performed.

In analyzing a problem, engineers must consider many factors, such as the strength of materials, stress concentration, deflection, and internal and an external forces.

Figures 1 to 13 represent four categories of visual modes:

1. Figures 1 and 10 show simple 3D line drawings of a typical structural member.
2. Figures 2, 4, 8, and 12 show colored 3D renderings of some typical structures.
3. Figures 3 and 6 show wire frame representations of some structures.
4. Figures 5, 7, 9, and 13 show 2D representations of some structures.

The visual modes for this study were developed in an attempt to include a fairly reasonable set of graphical representations commonly used in structural engineering analysis.

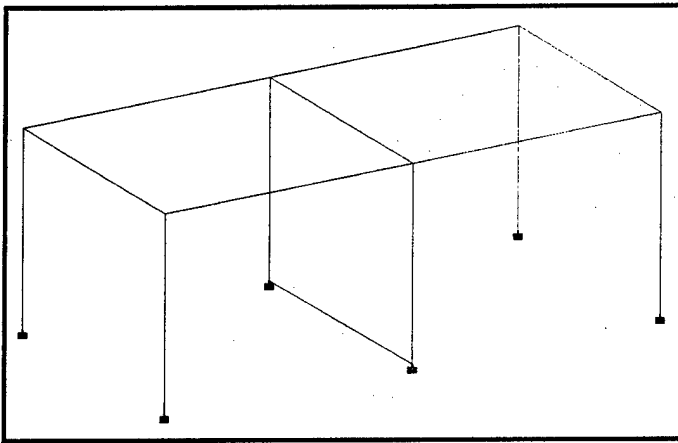

Figure 1. 3-D structure with shearwall and roof slabs.

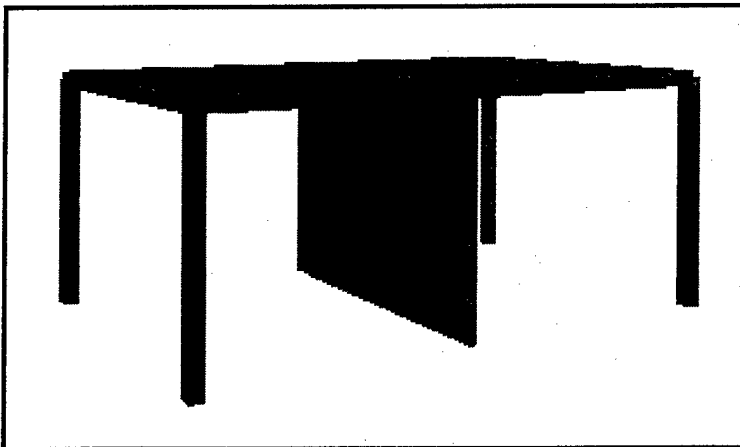

Figure 2. 3-D structure with shearwall and roof slabs.

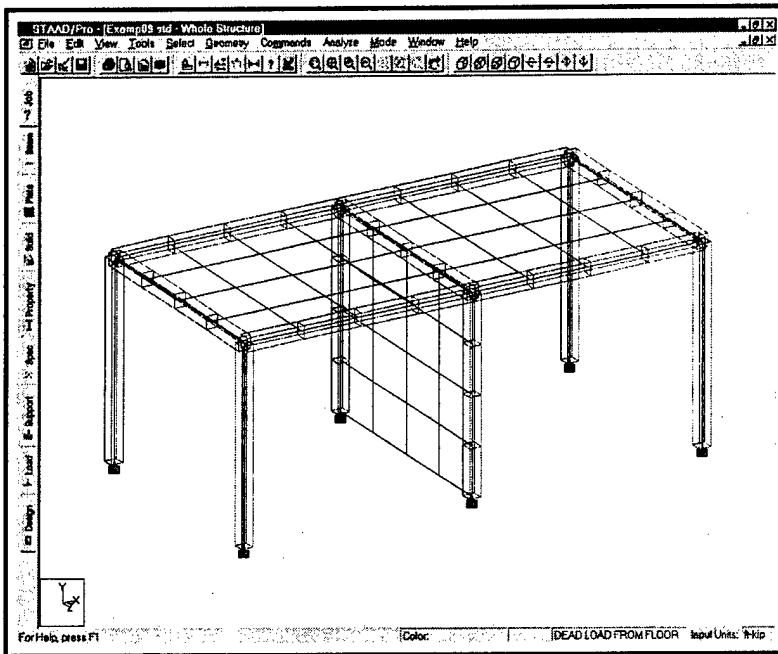

Figure 3. 3-D structure with shearwall and roof slabs

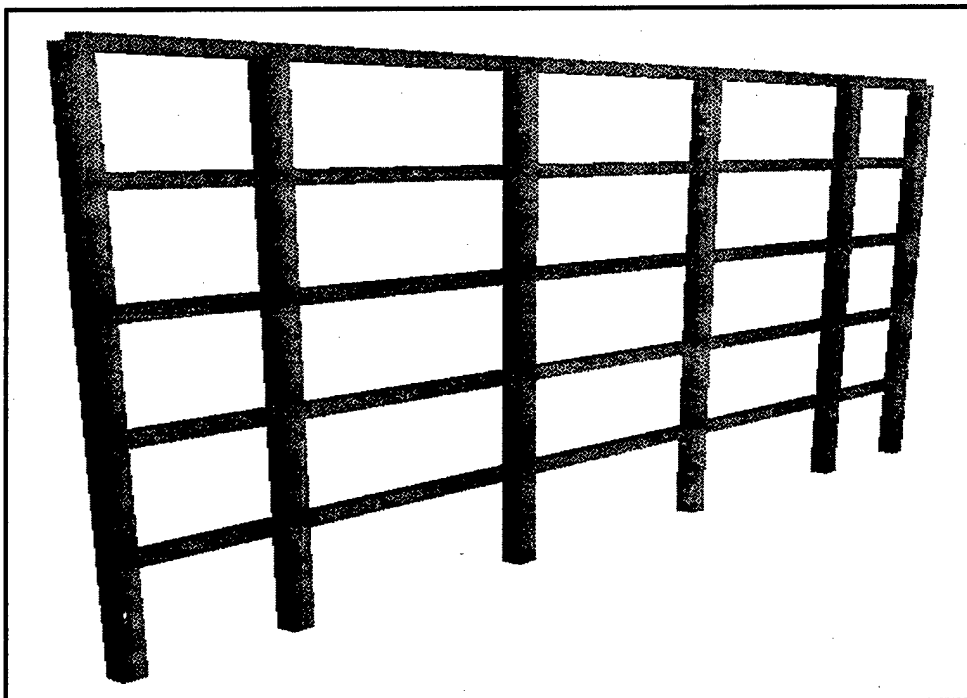

Figure 4. Plane frame (1).

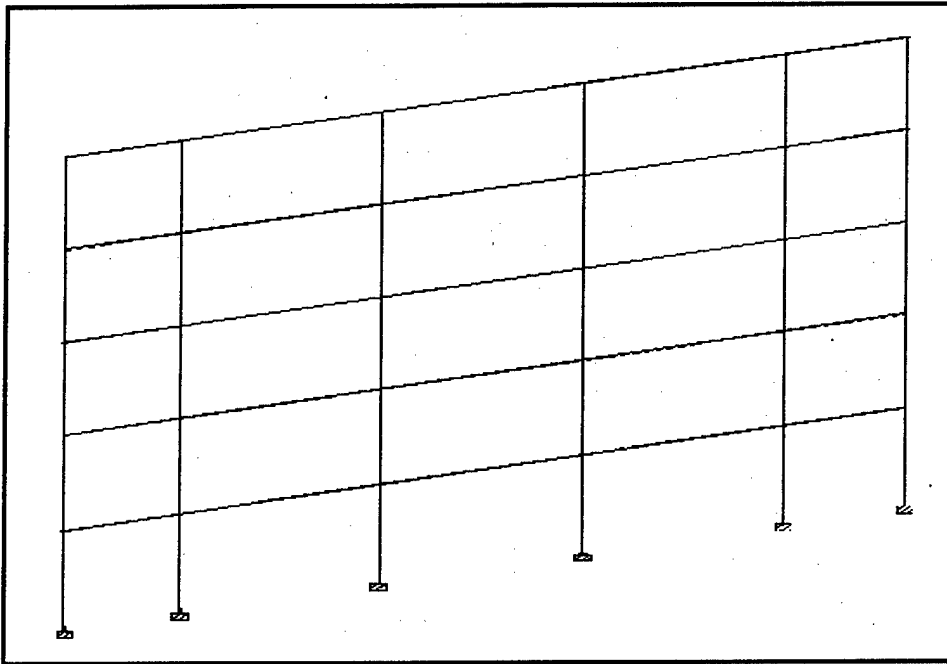

Figure 5. Plane frame (2).

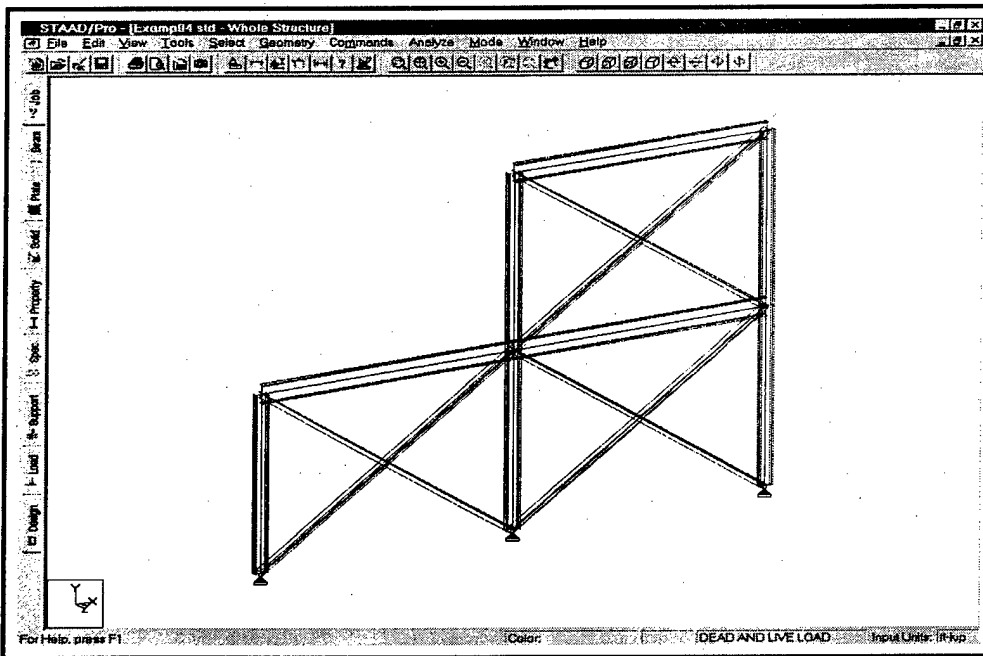

Figure 6. Plane frame (3).

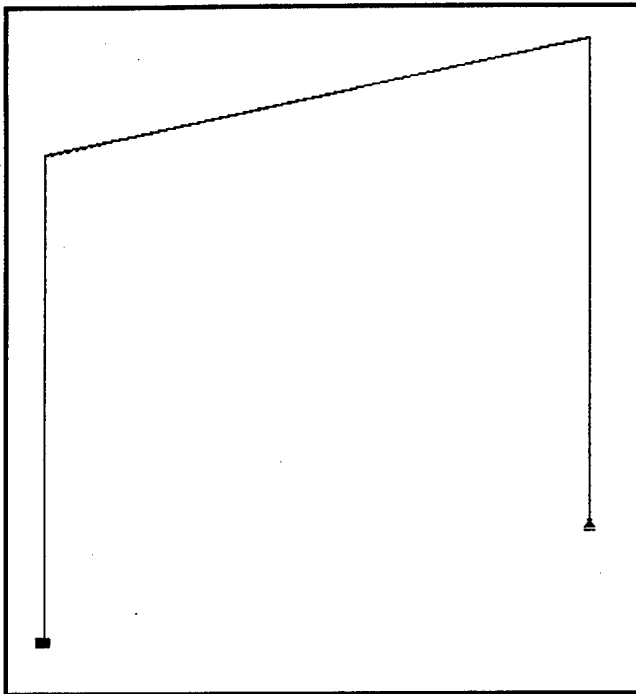

Figure 7. Plane frame (4).

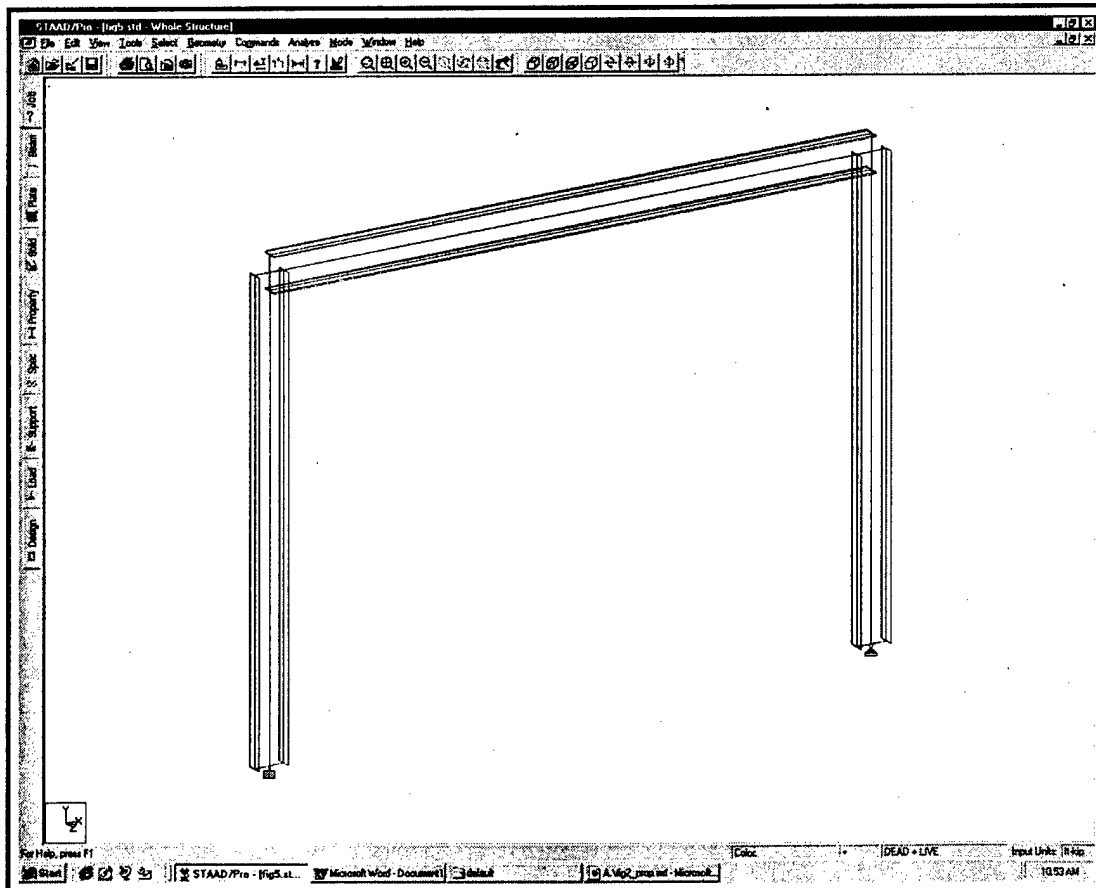

Figure 8. Plane frame (5).

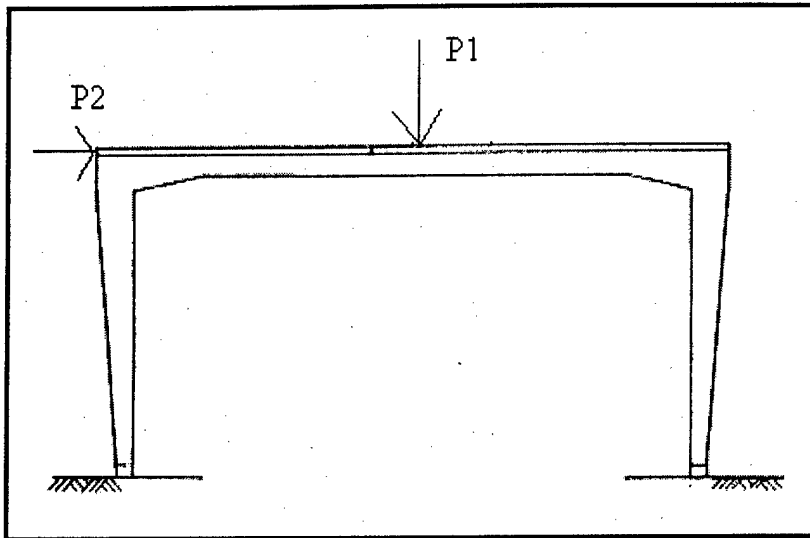

Figure 9. Plane frame (6).

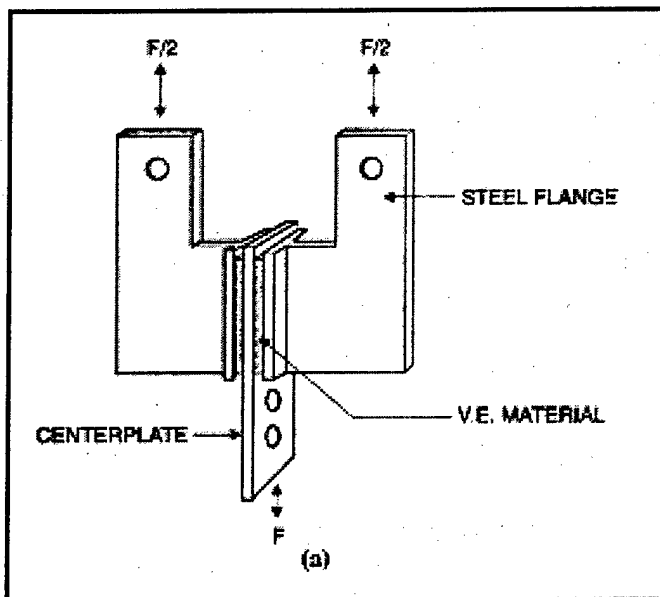

Figure 10. Flange-centerplate connection.

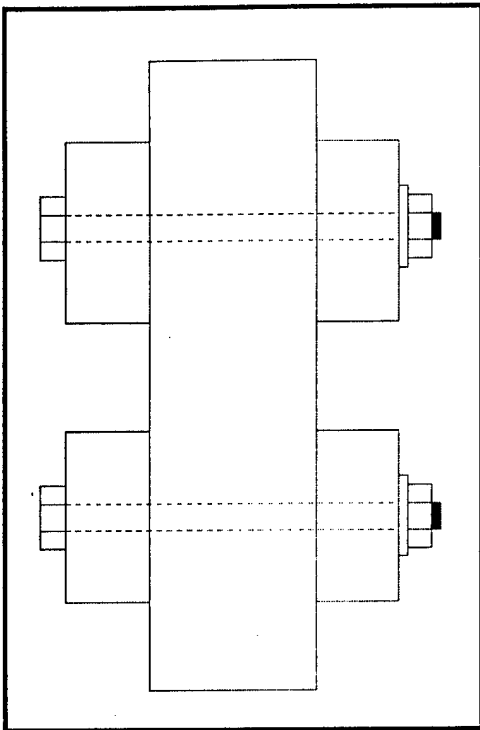

Figure 11. Detailed connection.

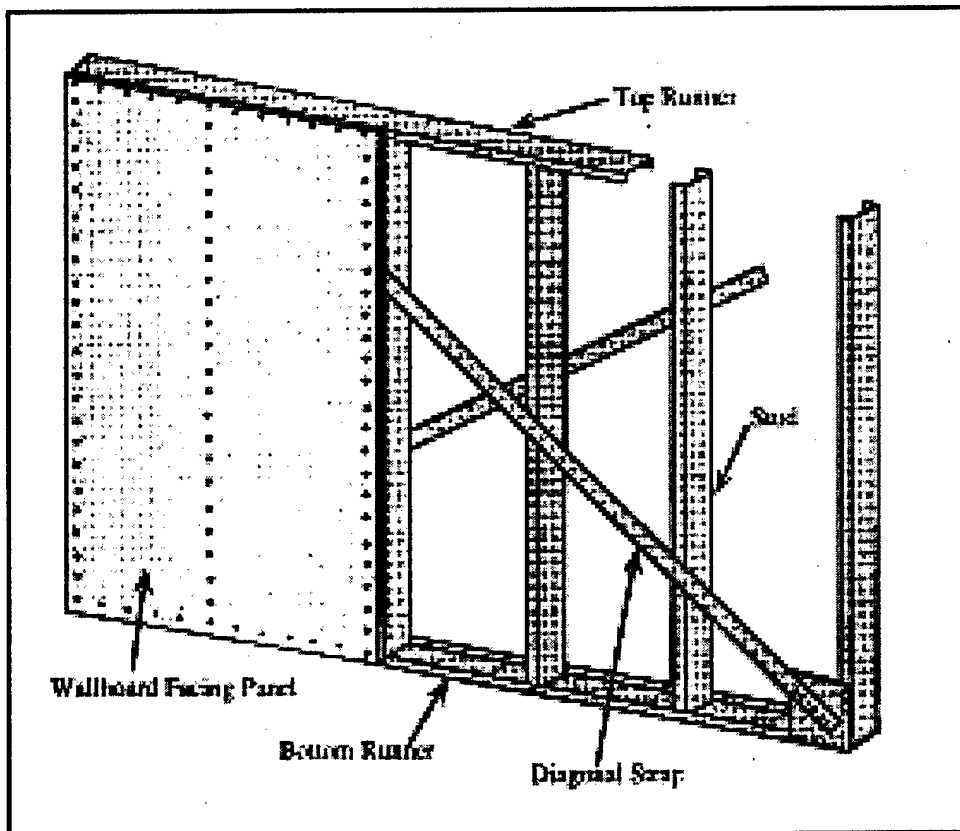

Figure 12. Wall section.

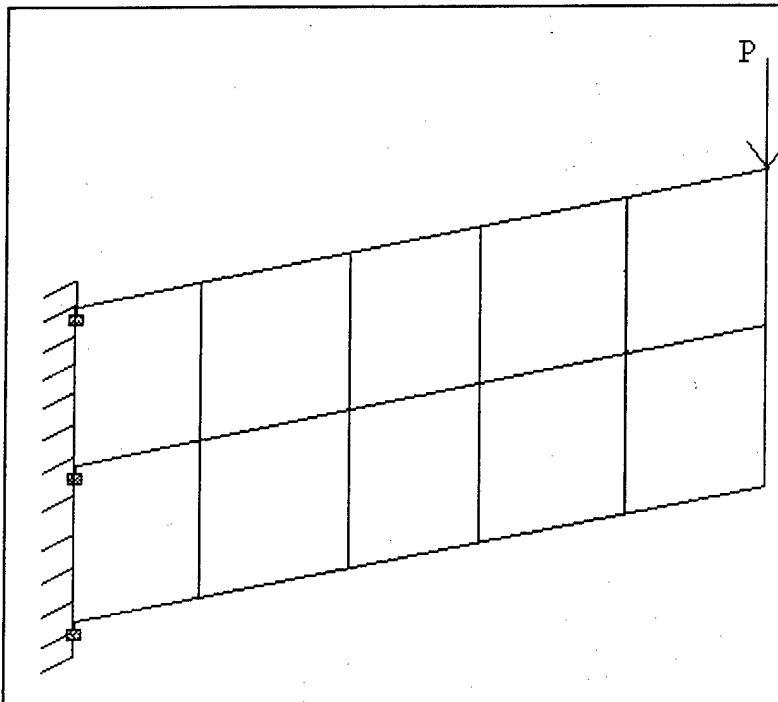

Figure 13. Cantilever beam.

Data Collection

The participants selected for this study were 30 structural engineering students that were taking summer classes at the California Polytechnic State University in the summer 1998. The students were contacted through their instructors and asked for their participation. The survey questionnaire was then mailed to them.

Data Analysis

Although the participants took the survey manually, the collected data were transferred electronically to a Questionnaire Programming Language (QPL) for data entry and processing. Data were analyzed and presented in various forms. This study included a descriptive and content analysis. Descriptive analysis characterizes the population, and content analysis collects information about the opinions and feelings of the participants.

Descriptive Analysis

Of the 30 survey questionnaires sent out, 14 completed survey questionnaires were returned (about 46 percent return rate). Out of the 14 participants, 10

were males and 4 were females. Eighty-six percent were classified as senior and 14 percent were classified as junior. Fourteen percent of the participants were less than 20 years old, 71 percent were between 21 to 25 years old, while 14 percent were between 26 to 30 years old. Most of the participants (about 93 percent) have experience in structural analysis.

Table 1 shows that 71 percent of the participants indicated that Figure 2 helped them better analyze a clear differentiation between shear walls and slabs of the given structure while about 29 percent indicated Figure 3. Figure 1, which was a wire frame representation of this structure, was not selected.

Table 1. Frequency of the visual modes that help participants best analyze a clear differentiation between shear walls and slabs.

Visual Modes	Frequency	Percent	Cumulative Percent
71.4	10		71.4
28.6	4		100.0
100.0	14		

A higher percentage of the participants selected Figure 2 gave the following reasons: Figure 2 is a colored rendering with a depth added to the structure. They indicated that this Figure was easy to understand because it was solid, because it used different colors to provide for a better visualization, and because they were able to see the surface as solid rather than as hidden lines.

Table 2 shows that 57 percent of the participants indicated that Figure 4 provides a clearer differentiation of the structure's members while about 43 percent selected Figure 6. Figures 4 and 6 are very similar visually. They are both in 3D and in color. The similarity in these figures explains why there was no significant difference in the selection as a visual mode for analysis.

Table 2. Frequency of the visual mode that helps participants best analyze a clear differentiation between beams and columns.

Visual Modes	Frequency	Percent	Cumulative Percent
Figure 4	8	57.1	57.1
Figure 6	6	42.9	100.0
N	14	100.0	

Table 3 shows that about 14 percent of the participants indicated that Figure 7 gives them best understanding of the supports; 21 percent chose Figure 8, and 64 percent chose Figure 9. Figure 9 is a plane frame represented with a line drawing. In addition, arrows on this drawing show the direction of both vertical and horizontal loads. It is apparent that the indicated directions of forces made this figure clearer than the rest.

Table 3. Frequency of the visual mode that gives the participants the best understanding of the supports.

Visual Modes	Frequency	Percent	Cumulative Percent
Figure 7	2	14.3	14.3
Figure 8	3	21.4	35.7
Figure 9	9	64.3	100.0
N	14	100.0	

Table 4 shows that about 21 percent of the participants indicated that 3D graphics best help them in a problem analysis while 79 percent indicated that both 2D and 3D graphics best help them. This finding is in agreement with the results reported by Edwards (1979), who stated that visual analysis and design developments are interactive acts involving recording ideas, analyzing problems, recognizing functions, and meaning in the drawings, and finding new forms and adapting them into the design. In other words, it takes more than one visual mode to understand a problem.

Table 4. Frequency of the form of visual mode that best helps the participants in a problem analysis

Visual Modes	Frequency	Percent	Cumulative Percent
3D	3	21.4	21.4
Both (2D & 3D)	11	78.6	100.0
N	14	100.0	

Table 5 shows that 64 percent of the participants agreed that for the visualization of a structural system, a 3D figure provides the best overall visualization while only 36 percent indicated both 2D and 3D work the best. This finding agree with Al-Rasheed (1997) who indicated in his study that 3D mode had on average fewer missing activities, missing relationships, and fewer invalid relationships. This also explained why some people preferred 3D visual modes to 2D visual modes.

Table 5. Frequency of the visual mode that provides the best overall visualization of structural system

Visual Modes	Frequency	Percent	Cumulative Percent
3D	9	64.3	64.3
Both (2D & 3D)	5	35.7	100.0
N	14	100.0	

Table 6 indicates that 29 percent of the participants indicated 2D figures provide more detailed information, about 43 percent chose 3D figures, while 29 percent of the participants stated that both 2D and 3D figures provide more detailed information.

Table 6. Frequency of the form of visual mode that can be used to provide more detailed information

Visual Modes	Frequency	Percent	Cumulative Percent
2D	4	28.6	28.6
3D	6	42.9	71.4
Both (2D & 3D)	4	28.6	100.0
N	14	100.0	

Table 7 shows that 36 percent of the students indicated that Figure 10 provides the best representation of the material being used, only 7 percent indicated Figure 11, and 57 percent indicated Figure 12 provides the best representation of the material being used.

Table 7. Frequency of the visual mode that provide the best representation of the material being used

Visual Modes	Frequency	Percent	Cumulative Percent
Figure 10	5	35.7	35.7
Figure 11	1	7.1	42.9
Figure 12	8	57.1	100.0
N	14	100.0	

Table 8 shows that 29 percent of the participants agreed that Figure 13 provided an adequate visual representation of a structural system, 57 percent disagreed, and the remainder did not know.

Table 8. Frequency of whether Figure 13 provides an adequate visual representation of a structural system

Opinions	Frequency	Percent	Cumulative Percent
Yes	4	28.6	28.6
No	8	57.1	85.7
Don't know	2	14.3	100.0
N	14	100.0	

Questions 20 to 23 of the questionnaire asked which of the following analyses do Figures 6, 10, 11, and 12 address better: member's properties, member's connectivity, shear wall's properties, stress problems, deflection problems, and other.

One participant indicated that Figure 6 addressed better properties of structure, four indicated connectivity, seven indicated shear wall's properties, five indicated stress problems, and four participants indicated deflection problems.

Eight participants indicated that Figure 10 addressed better properties of structure, eleven indicated connectivity, no one indicated shear wall's properties,

seven indicated stress problems, and four participants indicated deflection problems.

Three participants indicated that Figure 11 addressed better properties of structure, eleven indicated connectivity, no one indicated shear wall's properties, six indicated stress problems, and one participant indicated deflection problems. Nine participants indicated that Figure 12 address better properties of structure, seven indicated connectivity, eleven indicated shear wall's properties, four indicated stress problems, and two participants indicated deflection problems.

Table 9 summarizes the participants' selections for each figure.

Table 9. A summary of the participants' selections for each figure.

Figures	Properties	Connectivity	Shear wall properties	Stress problems	Deflection problems	Other	None
6	1	4	7	5	4	1	2
10	8	11	0	7	4	0	1
11	3	11	0	6	1	0	1
12	9	7	11	4	2	0	1

Content Analysis

Question 7 of the questionnaire asked the participants to explain why the visual modes they chose in Question 6 best give a clear differentiation between shear walls and slabs. Of the choices given: 10 participants selected Figure 2 and four participants selected Figure 3 (Table 10).

Table 10. Participants explanations why the visual modes they chose in Question 6 best give a clear differentiation between shear walls and slabs.

	Figure 2	Figure 3
Reason for choice	<ol style="list-style-type: none"> Two participants indicated Figure related to building around them. Three participants indicated it was a solid structure. 	<ol style="list-style-type: none"> Presents a more realistic skeleton Show the locations of the slab and shear walls. There is too much of the same color in Figure 2 and it would help to have some depth to the walls. It is more detailed than the others

Question 9 of the questionnaire asked the participants to list the type of analyses that they can perform using the figure chosen in Question 8 (Table 11).

Table 11. Participants' list of type of analyses that they can perform using the figure chosen in Question 8.

	Figure 8	Figure 6
Reason for Choice	<ol style="list-style-type: none"> 1. Two participants indicated it helps in stability analysis. 2. Helps in analysis of static loads 3. Shows how loads are carried and dispersed. 	<ol style="list-style-type: none"> 1. Two participants indicated model could give idea of the size of the columns and beams.

Question 17 of the questionnaire asked the participants were asked to explain the reasons for deciding that an analysis can be done using more than one visual mode. The following reasons were given for using more than one visual mode:

1. They provide more information (6 participants)
2. Things need to be looked at from different perspectives
3. For better visualization (2 participants)
4. It depends on the complexity of the subject.

Question 19 of the questionnaire asked the participants to explain the limitations of Figure 13, if there were any.

The participants listed the following limitations:

1. Does not show thickness of beams nor properties (3 participants)
2. Does not show materials (2 participants)
3. Cannot visualize beam-wall connections (5 participants)
4. Needs 3D picture (2 participants).

Discussion

Visualization is a powerful tool for exploring and analyzing problems. It has the potential to facilitate effective communication between designers and engineers. This study revealed several visual modes representing structural systems that can help engineers understand and analyze structural problems. Visualization facilitates perception, pattern, and form recognition. The more information that visual cues can carry, the more opportunities there are to analyze problems correctly. The visual modes used in this study were randomly selected based on commonly used structural graphics representations. These can be categorized into: 2D line drawings, 3D colored graphics, and 2D and 3D graphics with details and labels.

2D Line Drawings

Many participants did not select Figures 1, 5, 7, 9, or 13, which are the simplest form of 2D line drawings, as the best visual modes for analyzing problems. More participants selected a combination of 2D and 3D graphics. It is apparent that by changing 2D graphics to 3D graphics and by applying texture and color, it became easier to assess more detailed information. In 3D rendered graphics, expanded quantitative scales to analyze problems and understand relationships are more evident. Also, multicolored backgrounds and depth provided by 3D graphics allowed data to be compared and analyzed easily.

3D Colored Graphics (Rendered Graphics)

Rendering adds dimension to data plots through color, shape, size, and thickness. For instance, participants in this study reported that Figure 2, a 3D color rendering of a shear wall and roof slab, was easy to visualize because it was a solid structure. It gives the opportunity to see relationships from different angles.

2D and 3D Graphics with Details.

When additional information is added to any visual mode, it increases the understandability and usability of the mode. For instance, when arrows were added to Figures 9 and 10 to show the direction of both vertical and horizontal loads, the figures became easier to understand. It is apparent that the indicated directions of forces made these figures clearer than the rest.

The elements used to create visual modes are like words. If put together one way, they have limited value. If put together another way, they can convey a wealth of information and lead to more informed decisions. However, it is easier to communicate with more information than with less. Table 4 shows that about 21 percent of the participants indicated that 3D graphics best helps them in a problem analysis, but 79 percent indicated that both 2D and 3D graphics help the most. This finding corroborates Edwards' (1979) findings, which hold that visual analysis and design developments are interactive acts involving recording ideas, analyzing problems, recognizing functions, and meaning in the drawings, and finding new forms and adapting them into the design. In other words, it takes more than one visual mode to understand a problem.

There seems to be an apparent contradiction between the reports in both Tables 4 and 5. Table 4 shows that about 79 percent indicated that both 3D and 2D graphics best help them in a problem analysis. Table 5 shows that about 64 percent indicated that 3D graphics provide the best overall visualization of the

structural system. These results can be explained from different point of views. First, by the participants may have defined "problem analysis" and "overall visualization" differently. It may be easier to use certain visual modes to analyze the strength of material while other visual modes may be appropriate for general overview of structural integrity. Also, other variables such as age, experience, and education may be responsible for this apparent contradiction.

3 Conclusions and Recommendations

Engineers use different symbols and configurations in their drawings to explore various solutions and to communicate design concepts with each other. For example, an architect uses bubble diagrams to indicate spatial arrangements, and symbols to show natural lighting and light rays. When analyzing problems, engineers use a combination of 2D and 3D, color rendering, isometric, perspective, or line drawing to illustrate problems. In general, various visual modes appear to enhance engineers' visualization of problems. The use of visual modes can help engineers and architects to collaborate and communicate various problems effectively. This study concludes that a combination of visual modes enhance problem analysis and design.

Application of visualization is not limited to engineering problem analysis. There is a need for visualization software packages that offer capabilities for 3D work, solid modeling, and database links to other applications. Specifically, the ability to create 3D models for use in multiple applications will offer architectural and engineering professions such benefits as: more cost-efficient creation of design data, the capability for project analysis and error detection before building, and elimination of manual data transfer. Since the purpose of this study was to offer an explanation of how engineers communicate with each other and how visual modes influence their decisionmaking process, it is important to note how visual modes are used in other disciplines in communication. The visual modes sampled in this study were limited to commonly used visual modes; the scope of this study could well be expanded by including other visual modes such as isometrics, perspectives, sketches, and four-dimensional drawings.

Understanding how visual modes work across various disciplines will facilitate effective communication and better collaboration between practitioners of those disciplines. This study identified common visual modes used by structural engineers; however, the visual modes used by electrical engineers, mechanical engineers, software engineers, and architects were not identified.

Further studies to investigate and address the following questions are recommended:

1. What visual modes do architects, mechanical engineers, electrical engineers, and interior designers use often in analyzing problems and stimulating design thinking?
2. What visual modes lead to effective collaboration?
3. How do engineers reason with various visual modes?

References

- Al-Rasheed, K.A. (1997). "Construction Schedule Logic Development: The Impact Of Visualization (Animation, Planning)." *Dissertation Abstracts International*, 58(10B), 5524. (University Microfilms No. AAG9812845).
- Do, E.Y. (1998). "The Right Tool at the Right Time: Investigation of Freehand Drawing as an Interface to Knowledge-Based Design Tools." *Dissertation Abstracts International*, 59(11A), 3990, 00350. (University Microfilms No. AAG9912524).
- Eastman, C. (1968). "On the Analysis of Intuitive Design." in *Emerging Methods in Environmental Design and Planning*, Gary T. Moore, ed. 21-37. Cambridge: MIT Press.
- Edwards, B. (1979). *Drawing on the Right Side of the Brain: A Course in Enhancing Creativity and Artistic Confidence*. Los Angeles: J.P. Tarcher.
- File, 1997. "Visualizing the Future." Available through URL:
http://www.syllabus.com/archive/EngSci_Syll/EngSci_1/Visualizing_the_future.txt
- Gallagher, R. (1995). *Computer Visualization: Graphic Techniques for Scientific and Engineering Analysis*. Florida: A Solomon Press Book.
- He, T. (1996). "Volumetric Virtual Environments (Rendering)." *Dissertation Abstracts International*, 58(07B), 3742. (University Microfilms No. AAG98011906).
- Patton, M.Q. (1987). *How To Use Qualitative Methods in Evaluation*. Thousands Oaks, CA: Sage.
- Suwa and Tversky (1996). "Thinking with Diagrams." Available through URL:
<http://www.mrc-cbu.cam.ac.uk/projects/twd/>
- Urban Wallace & Associates, 1997. "Should I Use Qualitative or Quantitative Research To Answer My Marketing Question?" Available through URL:
<http://www.uwa.com/marketing/consultants/research.htm>
- Winn, B. (1987). "Charts, Graphs, and Diagrams in Educational Materials." in D.M. Willows & H.A. Houghton (eds.), *The Psychology of Illustration: Vol. 1. Basic Research* (pp 152-198). New York: Springer-Verlag.

Appendix: Questionnaire

Application of Visualizations in Structural Engineering Problem Analysis

The purpose of this questionnaire is to collect data for use in identifying better visualization of structural engineering analysis. The intent is to determine the best way to represent the information or problems with various visual modes and displays. Please respond to each question. Questions 1 and 2 will help us determine how age and gender are related to the way people visualize problems. Confidentiality of your responses is assured.

1. What is your current age?

1. Less than 20 years

2. 21 to 25 years

3. 26 to 30 years

2. 31 to 35 years

3. 36 to 40 years

4. 41 years and above

2. What is your gender?

1. Male

2. Female

3. What is your academic standing?

1. Freshman

2. Sophomore

3. Junior

4. Senior

5. Graduate

6. Other _____

4. What is your field of specialization?

5. Do you have experience in structural engineering problem analysis?

1. Yes

2. No

6. Which of the following visual modes help you best analyze a clear differentiation between shear walls and slabs? CHECK ONE.

1. Figure 1

2. Figure 2

3. Figure 3

7. Explain your reasons for your answer to Question 6.

8. Which of the following visual modes help you best analyze a clear differentiation between beams and columns? CHECK ONE.

1. Figure 4

2. Figure 5

3. Figure 6

9. Please list the types of analysis you can perform using the visual mode selected in Question 8.

Refer to Figures 7 through 11 for Questions 10 and 11.

10. Which visual mode gives you the best understanding of the supports?

1. Figure 7

2. Figure 8

3. Figure 9

11. Which visual mode gives you the best understanding of the joints?

1. Figure 10

2. Figure 11

12. Which form of visual mode best helps you in a problem analysis?

1. 2D

2. 3D

3. Both

4. Don't Know

5. Other_____

13. Which form of visual mode provides the best overall visualization of structural system?

1. 2D

2. 3D

3. Both

4. Don't Know

5. Other_____

14. Which form of visual mode can be used to provide more detailed information?

1. 2D

2. 3D

3. Both

4. Don't Know

5. Other _____

15. Which visual mode provides the best representation of the material being used?

1. Figure 10

2. Figure 11

3. Figure 12

16. Would you say an analysis could be conducted using more than one visual mode?

1. Yes

2. No

3. Don't Know

17. If YES, explain your reasons below

18. Does Figure 13 provide an adequate visual representation of a structural system?

1. Yes

2. No

3. Don't Know

19. If NO, what are the limitations?

20. Which of the following analyses does Figure 6 address better?

(CHECK ALL THAT APPLY).

- 1. Member's properties
- 2. Member's connectivity
- 3. Shear wall's properties
- 4. Stress problems
- 5. Deflection problems
- 6. Other _____

21. Which of the following analyses does Figure 10 address better?

(CHECK ALL THAT APPLY).

- 1. Member's properties
- 2. Member's connectivity
- 3. Shear wall's properties
- 4. Stress problems
- 5. Deflection problems
- 6. Other _____

22. Which of the following analyses does Figure 11 address better?

(CHECK ALL THAT APPLY).

1. Member's properties

2. Member's connectivity

3. Shear wall's properties

4. Stress problems

5. Deflection problems

6. Other _____

23. Which of the following analyses does Figure 12 address better?

(CHECK ALL THAT APPLY).

1. Member's properties

2. Member's connectivity

3. Shear wall's properties

4. Stress problems

5. Deflection problems

6. Other _____

24. Please provide any other comments you may have about visualization of structural engineering analysis.

25. In trying to develop this questionnaire further, it would be helpful to have more examples of structural analysis problems and graphics. We would appreciate it if you could send us examples or could sketch/depict your ideas below. Any comments for improvements to this questionnaire are welcome.

Thank you for your time.

P.O. Box 9005
Champaign, IL 61826.
E mail: b-adeoye@cecer.army.mil
Tel: 1-800-USACERL
ATTN: Blessing Adeoye

CERL DISTRIBUTION

Chief of Engineers

ATTN: CEHEC-IM-LH (2)

ATTN: CEHEC-IM-LP (2)

ATTN: CECC-R

ATTN: CERD-L

ATTN: CERD-M

Defense Tech Info Center 22304

ATTN: DTIC-O (2)

9

08/99

REPORT DOCUMENTATION PAGE

Form Approved
OMB No. 0704-0188

Public reporting burden for this collection of information is estimated to average 1 hour per response, including the time for reviewing instructions, searching existing data sources, gathering and maintaining the data needed, and completing and reviewing the collection of information. Send comments regarding this burden estimate or any other aspect of this collection of Information, including suggestions for reducing this burden, to Washington Headquarters Services, Directorate for information Operations and Reports, 1215 Jefferson Davis Highway, Suite 1204, Arlington, VA 22202-4302, and to the Office of

1. AGENCY USE ONLY (Leave Blank)	2. REPORT DATE August 1999	3. REPORT TYPE AND DATES COVERED Final
----------------------------------	-------------------------------	---

4. TITLE AND SUBTITLE Application of Visualization in Structural Engineering Design	5. FUNDING NUMBERS 611024A162720 AT23 EC9
--	--

6. AUTHOR(S) Blessing Adeoye, Victor Aviles, and Beth Brucker
--

7. PERFORMING ORGANIZATION NAME(S) AND ADDRESS(ES) U.S. Army Construction Engineering Research Laboratory (CERL) P.O. Box 9005 Champaign, IL 61826-9005	8. PERFORMING ORGANIZATION REPORT NUMBER TR 99/77
--	--

9. SPONSORING / MONITORING AGENCY NAME(S) AND ADDRESS(ES) Headquarters, U.S. Army Corps of Engineers (HQUSACE) ATTN: CECER-CVT 20 Massachusetts Ave., NW. Washington, DC 20314-1000	10. SPONSORING / MONITORING AGENCY REPORT NUMBER
---	--

9. SUPPLEMENTARY NOTES
Copies are available from the National Technical Information Service, 5385 Port Royal Road, Springfield, VA 22161

12a. DISTRIBUTION / AVAILABILITY STATEMENT Approved for public release; distribution is unlimited.	12b. DISTRIBUTION CODE
---	------------------------

13. ABSTRACT (Maximum 200 words)
The addition of improved visualization capabilities to engineering design applications can help engineers visualize problems better, analyze problems more accurately, and find better solutions. Applications that involve visualization commonly use the visual modes of volume visualization, color shading, contour lines, animation, and surface representation techniques. However, little research has been done concerning the application of visual modes in structural engineering design analysis. This basic research study investigated how different visual modes influence engineers' decisions in solving problems, and attempted to determine significant differences between the effectiveness of various visual modes.

14. SUBJECT TERMS structural engineering visualization	engineering design structured design	15. NUMBER OF PAGES 40	16. PRICE CODE
--	---	---------------------------	----------------

17. SECURITY CLASSIFICATION OF REPORT Unclassified	18. SECURITY CLASSIFICATION OF THIS PAGE Unclassified	19. SECURITY CLASSIFICATION OF ABSTRACT Unclassified	20. LIMITATION OF ABSTRACT SAR
---	--	---	-----------------------------------