

**NAVAL POSTGRADUATE SCHOOL
Monterey, California**



THESIS

**DIGITAL VIDEO IMAGERY AND
WIRELESS COMMUNICATIONS FOR LAND-BASED
RECONNAISSANCE MISSIONS**

by

James E. Munroe II
and
Arthur J. Pasagian

September 1999

Thesis Advisor:
Associate Advisor:

Rudolph P. Darken
Terrance C. Brady

Approved for public release; distribution is unlimited.

DTIC QUALITY INSPECTED 3

19991213 077

REPORT DOCUMENTATION PAGE

Form Approved
OMB No. 0704-0188

Public reporting burden for this collection of information is estimated to average 1 hour per response, including the time for reviewing instruction, searching existing data sources, gathering and maintaining the data needed, and completing and reviewing the collection of information. Send comments regarding this burden estimate or any other aspect of this collection of information, including suggestions for reducing this burden, to Washington headquarters Services, Directorate for Information Operations and Reports, 1215 Jefferson Davis Highway, Suite 1204, Arlington, VA 22202-4302, and to the Office of Management and Budget, Paperwork Reduction Project (0704-0188) Washington DC 20503.

1. AGENCY USE ONLY (Leave blank)		2. REPORT DATE September 1999	3. REPORT TYPE AND DATES COVERED Master's Thesis	
4. TITLE AND SUBTITLE : DIGITAL VIDEO IMAGERY AND WIRELESS COMMUNICATIONS FOR LAND-BASED RECONNAISSANCE MISSIONS			5. FUNDING NUMBERS	
6. AUTHOR(S) Munroe, James E. and Pasagian, Arthur J.				
7. PERFORMING ORGANIZATION NAME(S) AND ADDRESS(ES) Naval Postgraduate School Monterey, CA 93943-5000			8. PERFORMING ORGANIZATION REPORT NUMBER	
9. SPONSORING / MONITORING AGENCY NAME(S) AND ADDRESS(ES) National Reconnaissance Office 14675 Lee Road Chantilly, Virginia 20151-1715			10. SPONSORING / MONITORING AGENCY REPORT NUMBER	
11. SUPPLEMENTARY NOTES The views expressed in this thesis are those of the author and do not reflect the official policy or position of the Department of Defense or the U.S. Government.				
12a. DISTRIBUTION / AVAILABILITY STATEMENT Approved for public release; distribution is unlimited.			12b. DISTRIBUTION CODE	
13. ABSTRACT (<i>maximum 200 words</i>) Information superiority is a critical element of warfare. The commander who makes good decisions and executes these decisions at a superior tempo in the face of uncertainty and constrained time, most often leads his forces to victory. The research presented in this thesis seeks to provide superior information to the Commander in a visual form. This thesis explores, analyzes, and performs a proof-of-concept implementation for a real-time digital video reconnaissance system from forward locations to the rear using wireless communication. This thesis defines the requirements behind the implementation of the system and identifies a prototype suite of equipment. It investigates emergent Commercial-Off-the-Shelf components to identify the equipment that satisfies the system requirements and takes full advantage of current technological advances. Design selection is based on an evaluation of each component against criteria of minimum requirements and selects the most compatible device. It performs an analysis of the prototype by evaluating system throughput used to transmit audio and real-time video imagery. Results of this analysis suggest implementation of the prototype is feasible and that it satisfies the information gathering process.				
14. SUBJECT TERMS Reconnaissance, Wearable Computers, Digital Video Imagery			15. NUMBER OF PAGES 99	
			16. PRICE CODE	
17. SECURITY CLASSIFICATION OF REPORT Unclassified	18. SECURITY CLASSIFICATION OF THIS PAGE Unclassified	19. SECURITY CLASSIFICATION OF ABSTRACT Unclassified	20. LIMITATION OF ABSTRACT UL	

NSN 7540-01-280-5500

Standard Form 298(Rev. 2-89)
Prescribed by ANSI Std. Z39-18

Approved for public release; distribution is unlimited

**DIGITAL VIDEO IMAGERY AND WIRELESS COMMUNICATIONS
FOR LAND-BASED RECONNAISSANCE MISSIONS**

James E. Munroe II
Captain, United States Marine Corps
B.S., Cornell University, 1990

Arthur J. Pasagian
Captain, United States Marine Corps
B.A., City University of New York, 1990

Submitted in partial fulfillment of the
requirements for the degree of

MASTER OF SCIENCE IN INFORMATION TECHNOLOGY MANAGEMENT

from the

**NAVAL POSTGRADUATE SCHOOL
September 1999**

Authors:



James E. Munroe II

Arthur J. Pasagian

Approved by:

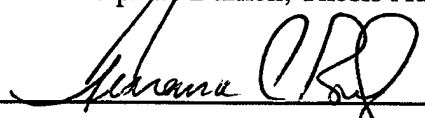
Rudolph P. Darken, Thesis Advisor

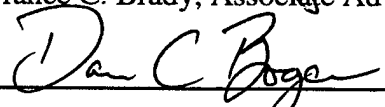
Terrance C. Brady, Associate Advisor

Dan C. Boger, Chairman
Information Systems Academic Group

ABSTRACT

Information superiority is a critical element of warfare. The commander who makes good decisions and executes these decisions at a superior tempo in the face of uncertainty and constrained time most often leads his forces to victory. The research presented in this thesis seeks to provide superior information to the Commander in a visual form. This thesis explores, analyzes, and performs a proof-of-concept implementation for a real-time digital video reconnaissance system from forward locations to the rear using wireless communication.

This thesis defines the requirements behind the implementation of the system and identifies a prototype suite of equipment. It investigates emergent Commercial-Off-the-Shelf components to identify the equipment that satisfies the system requirements and takes full advantage of current technological advances. Design selection is based on an evaluation of each component against criteria of minimum requirements and selects the most compatible device. It performs an analysis of the prototype by evaluating system throughput used to transmit audio and real-time video imagery. Results of this analysis suggest implementation of the prototype is feasible and that it satisfies the information gathering process.

TABLE OF CONTENTS

I. INTRODUCTION.....	1
A. BACKGROUND.....	1
1. Boyd's Theory.....	2
2. Current Philosophies and Doctrine.....	4
a. <i>Joint Vision 2010</i>	5
b. <i>Marine Corps Doctrinal Publication 6 (MCDP 6)</i>	6
B. A HUMAN FACTORS APPROACH.....	7
C. OBJECTIVES.....	8
D. ASSUMPTIONS.....	9
E. METHODOLOGY.....	10
F. ORGANIZATION OF THE THESIS.....	10
II. MISSION SETTING AND REQUIREMENTS.....	13
A. INTRODUCTION.....	13
B. MARINE CORPS GROUND RECONNAISSANCE.....	14
1. Marine Corps Ground Reconnaissance Organizations.....	15
a. <i>Force Reconnaissance Companies</i>	15
b. <i>Division Reconnaissance Companies</i>	15
2. Types of Marine Corps Ground Reconnaissance.....	15
a. <i>Close Reconnaissance</i>	16
b. <i>Distant Reconnaissance</i>	16
c. <i>Deep Reconnaissance</i>	17
3. Equipment.....	17
C. CONCEPT OF EMPLOYMENT.....	18
D. SUMMARY.....	19
III. METHODOLOGY FOR THE TRANSMITTAL OF REAL TIME VIDEO IMAGERY.....	23
A. INTRODUCTION.....	23
B. PURPOSE OF PROOF OF CONCEPT DEMONSTRATION.....	23
C. MINIMUM REQUIREMENTS AND DESIGN SELECTION.....	24
1. Wearable Computer (WearComp).....	24
a. <i>Minimum Requirements</i>	26
b. <i>Design Selection</i>	27
2. Digital Video Camera.....	29
a. <i>Minimum Requirements</i>	30
b. <i>Design Selection</i>	31
3. Imaging Software.....	33
a. <i>Minimum Requirements</i>	34
b. <i>Design Selection</i>	35
4. Night Imaging Device.....	37
5. Wireless LAN Cards.....	39
6. Cabling and Connectors.....	41
D. SUMMARY.....	44

IV. EXAMPLE OF A RECONNAISSANCE MISSION USING VIEW	45
A. INTRODUCTION.....	45
B. FICTIONAL SCENARIO.....	45
1. Background.....	45
2. The Mission.....	46
C. SUMMARY	50
V. IMPLEMENTATION AND DATA ANALYSIS	53
A. INTRODUCTION.....	53
B. IMPLEMENTATION	53
1. Initial Preparation for the Scenario.....	53
2. The Order, Movement, and Communication	54
3. Capture of Digital Video Imagery	56
4. Video Imagery Under the Cover of Darkness.....	56
5. Receipt and Interpretation of Video Imagery	57
6. Termination of the Connection.....	58
C. DATA ANALYSIS	58
D. SUMMARY	62
VI. RECOMMENDATIONS	63
A. INTRODUCTION.....	63
B. IMPROVEMENTS TO THE PROTOTYPE	63
1. Technological Advances.....	64
2. Integration of Components	64
3. Automation of the Process.....	65
C. MILITARY IMPLEMENTATION CONCERNS.....	66
1. Security.....	66
2. Ruggedization.....	68
3. Communication Footprint.....	69
4. Integration into Existing Information Systems	69
5. Improved Optics	70
D. FOLLOW-UP RESEARCH	70
1. Video Compression Technology.....	70
2. Broadband Communication Sources.....	72
3. Requirements Analysis for the Broadband radio	74
4. Optimal Video Capture Software Products.....	74
5. Implementation of VIEW Over Viable Broadband Channel	75
6. Implementation of Multiple Nodes.....	75
7. Receiving Node Requirements Analysis	75
8. Integration of Complementary Technologies	75
9. Effects of Streaming Video Intelligence on the Traditional Leadership Hierarchy.....	76
10. Security.....	77
E. SUMMARY	77
LIST OF REFERENCES.....	79
INITIAL DISTRIBUTION LIST	81

LIST OF FIGURES

Figure 1.1 Boyd's Cycle.....	3
Figure 2.1 Interrelationships of the Types of Reconnaissance.....	16
Figure 3.1 The Via II PC Wearable Computer.....	29
Figure 3.2 The Sony DSR-PD1 Digital Video Camera.....	32
Figure 3.3 Microsoft NetMeeting (3.0) Software Conferencing Client.....	37
Figure 3.4 B.E. Meyers Dark Invader OWL.....	38
Figure 3.5 Sony/OWL Integration.....	39
Figure 3.6 Lucent's WaveLan IEEE 802.11 LAN Card.....	40
Figure 3.7 Aironet's PC 4800 Turbo DS LAN Cards.....	41
Figure 3.8 Nogatech's USB Live Video Capture Adapter	42
Figure 3.9 Nogatech's Notebook TV Kit.....	43
Figure 3.10 The VIEW System Diagram	43
Figure 5.1 Establishing a TCP/IP Connection	54
Figure 5.2 The "Call" Button in the NetMeeting User Interface	55
Figure 5.3 The Address Dialog Box.....	55
Figure 5.4 Using the Video Camera LCD Screen.....	56
Figure 5.5 Mounting the Night Vision Scope	57
Figure 5.6 Aironet Wireless LAN Statistics Utility Display.....	59
Figure 5.7 NetMeeting Video Options	60
Figure 6.1. FoNet VideoBeamer Receiver/Transmitter System.....	74

LIST OF TABLES

Table 3.1 Wearable Computer Minimum Requirements	27
Table 3.2 Digital Video Camera Minimum Requirements	31
Table 3.3 Imaging Software Minimum Requirements.....	35
Table 3.4 The VIEW Prototype Equipment Suite.....	44
Table 5.1 Data Rate Test Results	61

LIST OF ACRONYMS

ARG	Amphibious Readiness Group	FTP	File Transfer Protocol
		GB	Gigabyte
AVI	Audio Visual Interleave	GPS	Global Positioning System
BIOS	Basic Input Output System	HCI	Human Computer Interaction
BLT	Battalion Landing Team	HMD	Head Mounted Display
CINC	Commander in Chief	HTTP	Hypertext Transfer Protocol
CLF	Commander Landing Force	IEEE	Institute of Electrical and Electronics Engineers
CMC	Commandant of the Marine Corps	IP	Internet Protocol
CODEC	Coding/Encoding	ISO	International Standards Organization
COMSEC	Communications Security	JCS	Joint Chiefs of Staff
COTS	Commercial Off the Shelf	JPEG	Joint Photographic Experts Group
CPU	Central Processing Unit	JV	Joint Vision
DoD	Department of Defense	LAN	Local Area Network
FEBA	Forward Edge of the Battle Area	LCD	Liquid Crystal Display
FM	Field Manual	LEO	Low Earth Orbit
FMFM	Fleet Marine Force Manual		
ForceRecon	Force Reconnaissance		

MAC	Mandatory Access Control	OODA	Observe-Orient-Decide-Act
MAGTF	Marine Air-Ground Task Force	OS	Operating System
Mbps	Mega bits per second	PCMCIA	Personal Computer Memory Card
MB	Megabyte		International Association
MCDP	Marine Corps Doctrinal Publication	PC	Personal Computer
MCWL	Marine Corps Warfighting Laboratory	RAM	Random Access Memory
MEF	Marine Expeditionary Force	ROC	Reconnaissance Operations Center
MEU	Marine Expeditionary Unit	ROE	Rules of Engagement
MHz	MegaHertz	SATCOM	Satellite Communication
MPEG	Moving Picture Expert Group	SSL	Secure Socket Layer
NEO	Non-combatant Evacuation Operation	UAV	Unmanned Aerial Vehicle
NSA	National Security Agency	UHF	Ultra High Frequency
		USB	Universal Serial Bus
		VHF	Very High Frequency
		VIEW	Video Intelligence Enhanced through
			Wearable computers
		WearComp	Wearable Computer

ACKNOWLEDGEMENTS

The authors would like to acknowledge the Naval Postgraduate School Center for Reconnaissance Research, and the financial support of the National Reconnaissance Office (Advanced Systems and Technology) for permitting the purchase of the equipment used in this thesis.

The authors would also like to thank the Marine Corps Warfighting Laboratory for the donation of several pieces of equipment, which were integral to the pursuit of the research.

Professor Yun and LT Kurt Rothenhaus generously shared laboratory space, ideas and humor.

Lastly, a special thanks to Professor Darken whose assistance, guidance and dedication was instrumental.

I. INTRODUCTION

A. BACKGROUND

The success or failure of a unit in battle relies heavily on the decisions of the unit commander and subordinate leaders. Information superiority is a critical element of this aspect of warfare. The decision-making process employed by commanders is generally referred to as the OODA (Observe, Orient, Decide, and Act) loop. [MCDP 6, 1996]

The faster a commander can make informed decisions (the faster his OODA loop), the greater his ability to achieve objectives on the battlefield. The commander who makes good decisions and executes these decisions at a superior tempo in the face of uncertainty and constrained time most often leads his forces to victory. However, the decision-making process is most often constrained by the ability to gather, disseminate, and comprehend information such that it can be used effectively. The human decision-making process may tend to change under stress and time compression. As time is compressed and stress increases, decision makers may; rely on a limited fraction of the available information; concentrate more on decisions based on an obsolete understanding of the environment and less on situational awareness; and increase their micro-management of subordinates. [Zimm, 1999]

Current Marine Corps doctrine calls for the use of verbal and pencil sketch data in reconnaissance missions. [FM 5-170, 1998] Not only does this type of data tend to be error prone, but it is also time-consuming to collect and use. If reconnaissance data could be collected from the field in its natural form (imagery or text) and in a timely fashion, this would greatly increase the tempo of the commander's decision-making process. However, it is not safe to assume that more information is always better. Information

saturation can be a continual, real-life problem. A reconnaissance doctrine that called for widespread use of digital video imagery, voice, and textual data all streaming to the commander simultaneously would likely prove useless at best and harmful at worst.

One of the striking aspects of military life today is the increasingly rapid pace of change with regard to information technology in the armed forces. Everyday we are awed by new developments in science and technology and the military opportunities and threats they represent. The use of digital video images as information is an example of such a development.

Delivery of superior information to the commander in the form of imagery, is central to the research contained within this thesis. Enhanced information delivery for the purpose of improving a commander's ability to speed decision-making, requires a close examination of the decision making cycle.

1. Boyd's Theory

For crisis decision making, Boyd's cycle, developed by USAF Colonel John Boyd, is one of the most useful models of the decision making process. Boyd's cycle was developed with adversaries and opposing wills in mind. However, it can be applied in other crisis situations as well. Boyd's cycle describes conflict in a time-competitive environment, which is cyclic in nature. Two opposing wills present a series of unexpected and threatening situations to one another. The side that can not keep pace with the threatening situations is defeated. This happens regardless of the size, strength, or equipment possessed by the forces. Boyd's cycle has four distinctive phases; observation, orientation, decision, and action. Together they complete one cycle. Boyd's cycle is also known as the OODA loop. [MCDP 6, 1996]

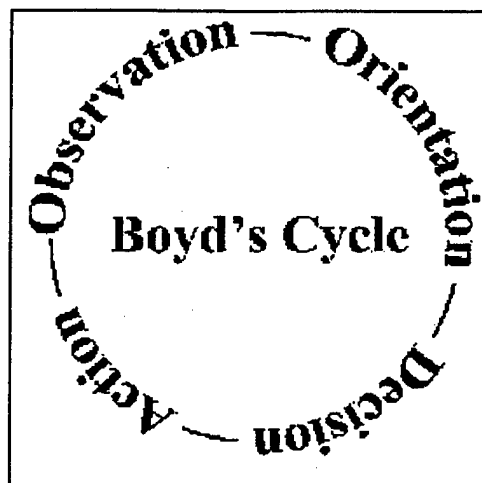

Figure 1.1 Boyd's Cycle.

The first phase is observation. Observation refers to the necessity of becoming aware, especially through careful and directed attention. Observation converts phenomena into data. The decision-maker must observe what is taking place and determine the circumstances under which he or she must function. Observation always involves one or more of the five senses. Sometimes we seek information and sometimes it is thrust upon us.

The second phase is orientation. Orientation is described as the state of locating or placing an item in relation to something else. It is aligning, positioning, or prioritizing of something with respect to a point of reference. Orientation is distinct from observation since this is when the initial assessment begins and some type of prioritization is necessary. Orientation allows one to use observation as a basis for thought. It is a mental "snapshot" of the incident. This is required because the situation is too fluid and changing to make a sound decision without making it static, even if only for an instant. Perhaps the best way to understand orientation is to think of it as a synopsis or summary of the previous observation.

The third step in Boyd's cycle is decision. Decision refers to the passing of judgment on an issue under consideration. This is the first step in which a commander attempts to control a situation in which he finds himself. This judgement determines what the commander's next course of action will be. Decision converts the information into orders. Based on orientation we make a decision; either immediate reaction or deliberate plan.

The last step in the OODA loop is action. Action refers to the state or process of acting or doing something; a deed. Action is where the decision is put into effect. The OODA loop is continuous, as you act you observe the results, the process starts all over again. It is possible and very probable, to have multiple OODA loops, in various stages, spinning at the same time, but not necessarily at the same rate; in fact, they probably won't spin at the same rate. The OODA loop reflects how command and control is a continuous, cyclic process.

The overarching goal in warfare is an increased operations tempo in order to overwhelm one's enemy by being able to observe, orient, decide, and act (OODA) faster than he is able to. "Speed is an essential element of effective command and control. It means shortening the time needed to make decisions, plan, coordinate, and communicate." [MCDP 6, 1996]

2. Current Philosophies and Doctrine

The implementation of a new technological tool must be conducted carefully. Standardization of equipment, interoperability, and associated relevant issues must be considered. The inspection of two existing documents which present ideas for the application of technology as a tool is necessary.

A common direction for each of the Armed Services is developed within Joint Vision 2010 (JV 2010). Since leveraging technological opportunities is central to JV 2010, it is necessary to consider the concepts put forth by the Joint Chiefs of Staff (JCS).

Further, the Marine Corps Doctrinal Publication 6 (MCDP 6) is addressed within this document in order to portray central themes of command and control theory and philosophy in the Marine Corps:

That command and control is not the exclusive province of senior commanders and staffs; effective command and control is the responsibility of all Marines. [MCDP 6, 1996]

a. Joint Vision 2010

Joint Vision 2010 (JV 2010) seeks to form a template for how our Armed Forces will prepare to fight and operate into the 21st century. The JCS plans to achieve dominance through JV 2010 by recognizing that the future of warfighting is embodied in improved intelligence and command and control. [JV 2010, 1996] Historically, technology embodies the tools that leaders and managers seek in order to manipulate a situation to produce favorable results. More than ever before, a command and control system is crucial to success on the battlefield and must support shorter decision cycles and instantaneous flexibility in an operational environment.

In preparing for the 21st century, Joint Vision 2010 develops four important operational concepts integral to the Armed Forces ability to dominate an adversary. These are (1) dominant maneuver, (2) precision engagement, (3) full dimensional protection and (4) focused logistics.

Of the four operational concepts put forth by Joint Vision 2010, those of dominant maneuver and precision engagement are central to the information superiority that may be achieved through the delivery of real time video imagery. Both concepts

allow our Armed Forces to gain a decisive edge through responsive command and control. Dominant maneuver allows forces to gain an advantage by controlling each aspect of the battlespace. [JV 2010, 1996] This is accomplished through a combination of decisive speed and tempo. Both speed and tempo in maneuver are achieved through the employment of improved sensors and real-time evaluation.

Precision engagement also allows forces to gain an advantage by shaping the battlespace. This is accomplished through high fidelity target acquisition, prioritized target requirements and accurate weapons delivery techniques. [JV 2010, 1996]

b. Marine Corps Doctrinal Publication 6 (MCDP 6)

According to the Commandant of the Marine Corps (CMC), the Marine Corps' view of command and control is based on the common understanding of the nature of war and the Corps' warfighting philosophy. It accounts for the timeless attributes of war, as well as the impacting features of the information explosion, resulting from modern technology. MCDP 6 addresses the complex environment of command and control (uncertainty and time) and theory of command and control (to include the OODA loop, image theory, and decision-making theory).

The operational environment is characterized by a dynamic, fluid situation. In such a chaotic setting, commanders and staffs must tolerate ambiguity and uncertainty, identify patterns, seek and select critical information, and make rapid decisions under stress. [MCDP 6, 1996] Command and control systems must therefore be planned as extensions of the human senses and processes to help commanders reduce uncertainty, form perceptions, react, and make timely decisions. This allows commanders to be effective during high-tempo operations. For these reasons, a

commander can ensure a more agile and decisive response to his environment than his enemy-- and that means victory on the battlefield.

B. A HUMAN FACTORS APPROACH

Aside from the obvious technological challenges to solving this problem are issues related to the people who will use these systems. The human factor in man-machine design has been shown on numerous occasions to be a stumbling block to success. Understanding how people work and how technology can best assist them in that work is critical to achieving a solution. In this case, understanding both the Marines in the field and the unit commander will drive the prototype design and requirements.

In many cases, people assimilate information more quickly and effectively as visual images than in text. This is particularly true of information that is image-based in its natural form rather than symbolic or alphanumeric. We might say that an image is the embodiment of our understanding of a given situation or condition. [Zimm, 1999]

Human beings do not normally think in terms of data or even knowledge. People generally think in terms of ideas or images — mental pictures of a given situation. Not only do people generally think in images, they understand things best as images and are inspired most by images.

Thomas J. Peters, *Thriving on Chaos: Handbook for a Management Revolution*.

For this reason, the introduction of digital imagery to the reconnaissance process is critical to the overall success of the mission. Reconnaissance is often based on imagery; the commander needs to “see” what the Marine in the field sees. But the best he tends to get is a crude pencil sketch on the back of a data form. We can do better. Furthermore, integrating imagery data with other data and correctly representing

information in its natural form such that it can be utilized effectively by the unit commander is a priority in this project.

C. OBJECTIVES

The purpose of this thesis is to identify a prototype suite of equipment that will provide the transfer of live images. This will furnish the commander with accurate information in real time and consequently, improve the decision making cycle. This thesis proposes a proof-of-concept implementation of a lightweight man-portable suite of equipment that will satisfy the information-gathering requirement by a reconnaissance team. The proposed system will take full advantage of the current COTS hardware and software technologies; such as Wearable Computers (WearComp), digital video cameras, and wireless communication.

The objective is to develop a system that is capable of delivering real-time imagery from forward deployed reconnaissance units to the commander in the rear, thus enhancing the commander's decision making capabilities. The research presented within this thesis will present the requirements, design, integration, implementation, and proof-of-concept demonstration of an experimental prototype. The system will provide high levels of availability, compatibility, modularity, and flexibility. The initial proof-of-concept demonstration sets the stage for further testing and evaluation.

This thesis examines the following research questions:

1. What are the functional requirements and constraints of Marine Corps reconnaissance units?
2. What is the appropriate system architecture to transmit real time video imagery from the tactical environment?

3. How can the system be effectively implemented and used?

4. What are the constraints of using such a system?

D. ASSUMPTIONS

Video applications are present today in many forms within the information technology marketplace. Generally, however, the bandwidth limitations associated with most networks have made the transmission of video cumbersome, impractical, expensive and of poor quality. The broadband push of the information technology industry is largely fueled by the increasing demand for a wide variety of video applications. The objective of transmitting real time video over a wireless network demands broadband connectivity from source to receiver.

One example of the response by industry to satisfy the growing demands for broadband access is the Teledesic Corporation. The Teledesic Corporation is building a global, broadband Internet-in-the-Sky. Using a constellation of Low-Earth-Orbit (LEO) satellites, Teledesic and its international partners are creating a worldwide network, with "fiber-like" bandwidth access to telecommunications services such as computer networking, broadband Internet access, high-quality voice, and other digital data needs. The Teledesic system is designed to support two-way connections that provide up to 64 Mega Bits per Second (Mbps) on the downlink and up to 2 Mbps on the uplink. This represents access speeds more than 2,000 times faster than today's standard analog modems. [Teledesic, 1999]

Teledesic expects service to begin in 2003. Coupled with advances in related technologies such as compression algorithms and cellular communication, the wireless transmission conducted within the proposed proof-of-concept will simulate that of

broadband service. Specifically, wireless LAN cards will serve as a surrogate communication platform within the scope of the proof-of-concept.

Further, in depth analysis in the communication, encryption and associated technologies will be conducted in Chapter VI.

E. METHODOLOGY

The following methodology was used in the preparation of this thesis:

1. Analysis of the requirements for Marine Corps reconnaissance and the reconnaissance reporting process.
2. Research of the current COTS hardware/software technologies to include: wearable computers, digital cameras, wireless LAN cards, and imaging software.
3. Development of a prototype suite of equipment in support of the reconnaissance reporting process utilizing the current technologies.
4. Conduct of a proof-of-concept implementation and analysis of the prototype suite of equipment to demonstrate the functionality as it applies to the reconnaissance reporting process.

F. ORGANIZATION OF THE THESIS

Chapter II provides background information on Marine Corps reconnaissance. It defines the organizations which conduct reconnaissance, the types of reconnaissance missions, and possible mission settings where each may be used. It concludes with the requirements for Marine Corps reconnaissance, describing the current capabilities, limitations, and constraints involved with Marine Corps reconnaissance.

Chapter III describes the methodology involved in selecting the prototype suite of equipment. It discusses the analysis of the minimum requirements and design selection of the various components which comprise the prototype.

Chapter IV provides a fictional depiction of a deep reconnaissance mission.

Chapter V reveals the results of the testing of the prototype and discusses the summary of the research.

Chapter VI provides recommendations and suggestions for further study, to include the processes and equipment.

THIS PAGE INTENTIONALLY LEFT BLANK

II. MISSION SETTING AND REQUIREMENTS

A. INTRODUCTION

The world watched the progression and outcome of Desert Storm and surely learned many lessons from it. Enemies in the future will go to great lengths to disguise, disperse, mobilize, camouflage, hide, and harden their critical resources, nodes, and weapons. They will use misinformation and deceit to try to increase the fog and friction on our side of the conflict.

Conflicts will be faster, more fluid, more dispersed, more uncertain, more lethal, and more difficult to get our arms around than anything we've ever seen before. The most difficult of these characteristics to deal with are the tempo and volume of future operations and the fluidity of the battlefield. High tempo, high volume operations will demand an enhanced ability to rapidly and efficiently communicate with and direct forces, during on-going operations. The critical element on the high tempo battlefield of the future is not so much the speed of our cycle, but the quality of decisions made in each phase of the OODA loop. To accomplish this we must understand what the enemy is doing before he gains any momentum on the battlefield. We must strive for a higher degree of certainty in future conflicts.

In order for the commander and his staff to make quality, timely decisions, they must have an enhanced picture of the battlefield. This thesis proposes a proof-of-concept implementation of a lightweight man-portable suite of equipment that can potentially dramatically enhance information gathering. The proposed video reconnaissance system, VIEW (Video Intelligence Enhanced through Wearable computers), will transmit video,

voice, and textual data via wireless means. Used as an information superiority tool, VIEW may provide an enhanced picture of the battlefield.

Exercise "Urban Warrior" is an ongoing, large-scale experiment being conducted by the Marine Corps. The exercise simulates a landing force operating within a scenario which the Marine Corps expects is more likely to occur as we embark into the new millennium. During the next few decades, the Marine Corps feels social and technological upheaval throughout the world will force confrontations in urban environments near coastlines which may harbor warlords, clans, and terrorists. [Garreau, 1999]

The urban environment near coastlines is precisely the environment for which Marines are best suited. The expeditionary nature of Marines is the fundamental role fulfilled by the Marine Air Ground Task Force (MAGTF). The most common vehicle for the expeditionary task is performed by the Marine Expeditionary Unit (MEU). A MEU embarked aboard U.S. Naval amphibious ships is one of the most formidable and routinely utilized tools for power projection by a theatre Commander-in-Chief (CINC).

The MEU commander has a variety of intelligence and reconnaissance tools available during the conduct of a deployment. Within this chapter, several options will be explored in order to help determine the requirements for Marine Corps reconnaissance and the reconnaissance reporting process.

B. MARINE CORPS GROUND RECONNAISSANCE

Currently there are many intelligence assets capable of framing the commander and his staff's mental image of the battlefield, i.e. UAV (Unmanned Aerial Vehicles), Radio battalion, satellites, etc. However, the commander's only direct human interface is Marine Corps ground reconnaissance. They are the commander's eyes and ears and can

literally draw or digitally provide the commander and his staff with a picture of the battlefield.

1. Marine Corps Ground Reconnaissance Organizations

Marine Corps ground reconnaissance is performed primarily by two organizations.

a. Force Reconnaissance Companies

The mission of Force Reconnaissance (ForceRecon) Companies is to conduct preassault and deep postassault reconnaissance operations in support of a landing force and its subordinate elements. There are three active and one reserve companies. All companies are composed of five platoons. All platoons consist of three 4 - 6 man reconnaissance teams.

b. Division Reconnaissance Companies

The mission of Division Reconnaissance Companies is to conduct ground reconnaissance and surveillance in support of a Marine Division and its subordinate elements. There are three active companies and one reserve battalion. The active companies are all composed of six platoons. All platoons consist of three 4 - 6 man reconnaissance teams.

2. Types of Marine Corps Ground Reconnaissance

There are three types of reconnaissance important to the commander and his staff; close, distant, and deep. [FM 34-130, 1994]

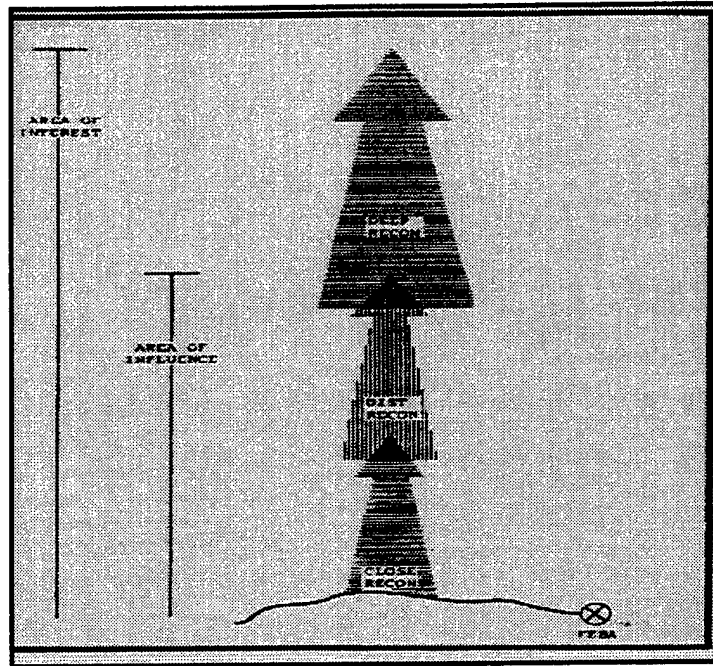

Figure 2.1 Interrelationships of the Types of Reconnaissance.

a. Close Reconnaissance

The term “close reconnaissance” describes ground reconnaissance and surveillance conducted in the area extending forward of the Forward Edge of the Battle Area (FEBA) and encompassing the near portion of the Commander, Landing Force’s (CLF) area of influence. It is directed toward determining the location, composition, disposition, capabilities, and activities of enemy committed forces, and it is primarily conducted by elements of units manning the FEBA. This type of reconnaissance is of primary interest to the infantry battalion commander and his staff. Infantry units conduct reconnaissance within this area of the battlefield.

b. Distant Reconnaissance

The term “distant reconnaissance” describes ground reconnaissance and surveillance conducted in the far portions of the CLF’s area of influence. It is directed

toward determining the location, composition, disposition, and movement of supporting arms and the reserve elements of enemy committed forces. The bulk of distant reconnaissance is conducted by the Reconnaissance Company, Marine Division. This type of reconnaissance is of primary interest to the division commander and his staff.

c. Deep Reconnaissance

The term "deep reconnaissance" describes ground reconnaissance and surveillance conducted in the CLF's area of interest. It is directed toward determining the location, composition, disposition, and movement of enemy reinforcements. The ForceRecon company is organized and trained to accomplish this type of reconnaissance mission. This type of reconnaissance is of primary interest to the MEF commander and his staff.

3. Equipment

The reconnaissance teams carry binoculars, Nikon cameras, and sketch pads when they go to the field. They have also experimented with digital cameras. These are the only means the teams have of transmitting their mental images of the battlefield to the commander and his staff. While in the field, they have no means of transferring visual images to the rear. Upon extraction, they can transfer their sketches and pictures to the commander's staff. However, much of their information loses value with time, and valuable time elapses from the moment a picture is taken to the time it is developed in the rear. In order to capitalize on the value of time, the teams have to resort to verbal descriptions of images while in the field. They transfer these verbal descriptions via man-packed radios.

The ForceRecon teams carry Satellite Communications (SATCOM), High Frequency (HF), Ultra-High Frequency (UHF), and Very High Frequency (VHF) radios.

Their primary means of communication is via satellite communications and their alternate is HF. Division Reconnaissance Companies' teams carry HF, UHF, and VHF radios. Their primary means of communication is via HF and their alternate is VHF retransmission.

C. CONCEPT OF EMPLOYMENT

By 2020, approximately seventy percent of the world's population will live in cities -- and -- seventy percent of these cities will be located along the world's coastlines. [MCWL, 1999]

While many reasons explain the repeated call to the Marines as the nation's 911 force, the logic is primarily associated with the expeditionary nature of Marines. It is in this setting where the MEU is routinely embarked aboard U.S. Naval shipping. The MEU is supported by the ForceRecon platoon, which normally deploys with the MEU and is located within the MEU command element. The ForceRecon platoon is mainly tasked with deep reconnaissance missions and surveillance operations in support of a landing force and its subordinate elements. The ForceRecon teams in the field communicate directly with the Reconnaissance Operations Center (ROC) located within the Surveillance and Reconnaissance Center (SARC). The SARC is attached to the MEF/Division G-2. The G-2 is responsible for bringing information the reconnaissance teams collect to the commander's attention.

Especially within the expeditionary environment, missions such as Non-combatant Evacuation Operations (NEO's) characterize operations in faster, more fluid, more dispersed, more uncertain, and more lethal conflict. The inherent uncertainty in expeditionary operations makes the ForceRecon teams the intelligence instrument of choice in a variety of mission settings. The surgical precision associated with the vast

capabilities of the ForceRecon teams serves to fulfill the concepts of dominant maneuver and precision engagement within JV 2010.

For these fundamental reasons, the authors' vision is to equip the ForceRecon platoon (i.e., one per team) with VIEW. The teams would literally be the forward eyes of the MEU commander. The teams would have the capability of capturing real-time video images of varying resolution in a variety of environments; from the unimpeded access of the desert, to the dense urban environment where factors such as light, signal loss due to masking, and cramped spaces serve to dramatically degrade the image.

Further, the ForceRecon teams are well versed with SATCOM. This permits the exploitation of wider bandwidths that typically accompany SATCOM relative to more traditional communications methods. As presented in the previous chapter, Teledesic's pioneering development of global broadband service through a LEO constellation is clearly the future direction for increased SATCOM performance.

Even by capitalizing on a portion of the bandwidth potential of a constellation such as Teledesic, a ForceRecon team would likely be capable of dramatically enhancing information gathering. Through the proof-of-concept demonstration of a lightweight man-portable suite of equipment, the proposed video reconnaissance system VIEW, may be the delivery mechanism of real-time video images from a ForceRecon team.

D. SUMMARY

Reconnaissance, in any setting, is a valuable tool that a unit commander uses to enable him to make faster and more informed decisions. This research proposes a proof-of-concept suite of equipment that will provide the transfer of live video imagery to the commander. Consequently the information portrayed by the live video images will vastly

improve the decision making cycle. The proposed solution must operate under the following constraints.

1. Be lightweight and man-portable, so not to constrict or hinder the movement of the Marine. The proposed solution will add greater flexibility and efficiency by removing heavy, older items (i.e., cameras and radios) and replacing them with smaller, lighter, more capable items (i.e., wearable computers).
2. Take full advantage of available lines of communication. It will provide voice communications as well as the capability of sending live video transmissions.
3. Be capable of operating in a night environment. A night capability enables a reconnaissance team to operate under the cover and stealth of darkness.
4. Take full advantage of COTS technologies. Using existing and emerging COTS technologies will provide an immediate solution to the problem as compared to the lengthy DoD acquisition process. An added benefit of COTS technologies is interoperability. COTS availability in this technology genre is of the variety where integrating like-systems is particularly easy to achieve. Further, using COTS for the system ensures the concept of modularity. This makes replacing obsolete components more judicious rather than discarding the entire system.
5. Provide information that is responsive and timely. It will provide immediate visual feedback in a digital video format concerning a location or target of interest instead of the delay associated with waiting for the return of the reconnaissance team and their still-camera.
6. Provide information that is accurate, clear, and concise. It will provide the accuracy and clarity of a data transmission of imagery, instead of the ambiguity and uncertainty usually associated with a radio transmission or hand-drawn data.

7. Provide detailed information that can be used for further inspection. It will provide the capability to select, freeze and capture a still image from a digital video transmission. The digital still image can then be easily manipulated and stored, instead of the data being provided in a voice or hand-written format.
8. Be capable of being operated by personnel with limited training. The COTS technologies provide a solution that can be mastered in a short period of time, instead of the current system, which may take years to gain adequate proficiency through intense and grueling training.

THIS PAGE INTENTIONALLY LEFT BLANK

III. METHODOLOGY FOR THE TRANSMITTAL OF REAL TIME VIDEO IMAGERY

A. INTRODUCTION

The Marine Corps, as it has always done when faced with uncertainty and challenge, is turning to our unequaled ability to innovate and adapt. Just as we did at Culebra prior to World War II, we are today, turning to experimentation. We are looking at new tactics, new organizations, and new technologies. Some experiments will succeed, some will fail, all will help us prepare a capable force for the uncertainties ahead.

General Charles C. Krulak, 31st Commandant of the Marine Corps

This chapter proposes a man-portable suite of equipment that will enhance the decision-making capabilities of unit commanders in the Marine Corps. The proposed system is named VIEW (Video Intelligence Enhanced through Wearable computers), highlighting the processing of video imagery through a lightweight and hands-off wearable computer. VIEW will take full advantage of the current COTS technologies and equip forward units (reconnaissance teams) with the system. The teams would literally be the forward eyes of the commander. The teams would have the capability of capturing real-time video imagery of varying resolution and compression. The real-time video imagery would then be wirelessly transmitted to the commander and his staff. The chapter also outlines the analysis of the minimum requirements, design selection used to select the individual components that will transmit real-time video imagery with VIEW.

B. PURPOSE OF PROOF OF CONCEPT DEMONSTRATION

The purpose of the proof of concept is to match the eight constraints generated in Chapter II with a prototype suite of equipment in the system called VIEW. The development of the prototype will consider the assumptions presented in Chapter 1 while

taking full advantage of current COTS technologies. The VIEW prototype will equip a Marine performing reconnaissance with a wearable computer (WearComp), digital video camera, a night imaging device, imaging software, a communications suite in the form of wireless LAN cards, and associated cables and connectors.

The heart of the system will be the WearComp; all other components must connect to and be compatible with it. The WearComp will provide the necessary processing, storage, and communication functionality for the prototype. The digital video camera will eliminate the need for handling still-images (35mm or digital) and through the imaging software, will provide the capability to capture specific frames of interest within the streaming video (i.e. building, bridge) for later examination. A night imaging device is also central to the capability requisite within VIEW. In order to deploy VIEW in a wide variety of mission settings, the night imaging device must be easily integrated with the digital video camera. The wireless LAN cards will be the communications media for the prototype, serving as a surrogate communications system in place of a broadband SATCOM service such as Teledesic.

C. MINIMUM REQUIREMENTS AND DESIGN SELECTION

1. Wearable Computer (WearComp)

Wearable computers (WearComp) have the full functionality of a computer system, but in addition to being a fully featured computer, they are also inextricably intertwined with the wearer. Defined, wearable computing facilitates a new form of human-computer interaction. Always on and always ready and accessible. This is what sets the WearComp apart from other wearable devices such as wristwatches, regular eyeglasses, or wearable radios. Unlike these other wearable devices that are not

programmable (reconfigurable), the WearComp is as reconfigurable as the familiar desktop or mainframe computer. [Mann, 1998]

One of the most appealing aspects to the WearComp today, is the minimal human manipulation required. This is achieved by interactive, "on-the-go" manipulation. For example you can do other things while filming video. Another feature which minimizes human manipulation is hot swapping of batteries. Hot swapping involves the use of a power cable, which permits the connection of more than one battery. For example, batteries 1 and 2 are both connected to the power cable. When the battery 1's power is consumed, battery 2 begins supplying power to the central processor of the WearComp. At that moment, the completely discharged battery 1 may be inserted into the charging station for recharging while battery 3 is placed into the power cable previously occupied by battery 1. This ensures the user does not have to disassemble or "pause" in order to replace batteries or troubleshoot.

Today, most WearComps offer similar performance to those of most desktops, laptops, and handheld devices. The integration of peripherals has also been achieved by most WearComp manufacturers. Video, audio, and other components are easily integrated through a variety of ports (i.e.: serial or comm ports).

While battery life is a critical issue with any portable, handheld, or wearable device, the advent of longer lasting lithium ion batteries and hot swapping of batteries has reinforced the "ready and accessible" characteristic within wearable computers.

The WearComp is the heart of the VIEW prototype. WearComp companies offer their wearable with any one of the popular Operating Systems (OS) installed. These are Windows 95 or 98, Windows NT, Unix, and Linux. The leading companies that are currently manufacturing WearComp devices are Via Inc., and Xybernaut. The

differences between individual brands and devices reside in the cost, amount of RAM, secondary storage space, availability of serial connectors, flash memory and PC-card slots, and use of color LCD's, Head Mounted Displays (HMD), or flat panel screens.

a. Minimum Requirements

During the analysis of the requirements, the minimum capabilities were determined by establishing what functionality was required to perform the proof-of-concept. The following capabilities are required for the WearComp:

1. It must be compatible with all the other components and capable of interfacing with all the other components simultaneously.
2. It must have two type II Personal Computer Memory Card International Association (PCMCIA) slots. The popularity of these slots will provide an interface with a wide variety of peripherals. One slot will be used by the wireless LAN card and the other may be used for interface with the digital video camera.
3. It must have a Universal Serial Bus (USB) port. The new standard in the Personal Computer (PC) world allows options beyond the two type II PCMCIA slots for interface between the WearComp and other devices.
4. It must have an ergonomically sound output display; one which may be stored when not in use to permit the user to perform other actions. The display device must also serve as an input device. Either through a touch screen or a pen interface, the user will not have access to a keyboard in a tactical environment. A minimum of 640x480 resolution. This ensures detail is readable without significant difficulty.

5. It must have a minimum of 32 MB of RAM and at least 2 GB of secondary storage or hard disk space. The RAM and hard disk will provide the space and memory needed to process the complex imaging software applications.

b. Design Selection

During the selection phase, specific components were identified. The search for possible components was narrowed down based upon the minimum capability criteria generated during the analysis phase. Each component was then selected based upon its ability to satisfy the functionality and requirements necessary to perform the proof-of-concept. Both wearable computers were evaluated to select the handheld that met the requirements. The Via II PC and Xybernaut MA IV were evaluated through extensive hands-on testing.

Mfr. Model	CPU	RAM	Hard Disk Space	Output Display and Resolution	Serial Port	USB Port	PCMCIA Slots
Xybernaut MA IV	200 MHz Pentium MMX	32MB	2.0 GB	Tablet: 640x480 and HMD: 352x288	YES	YES	(2) Type-II
VIA II PC	180 MHz Cyrix	64MB	3.2 GB	Tablet: 640x480	NO	YES	(2) Type-II

Table 3.1 Wearable Computer Minimum Requirements.

The Via II PC WearComp was selected for the proof-of-concept (Figure 3.1). The selection was made based upon the following specifications:

1. The Via II wearable is the more ergonomically sound product. The flexible design of the Via II places the WearComp in the small of the

back. This configuration distributes the weight evenly and allows the user a great deal of freedom of movement. Bending at the knees, jumping, rolling and other actions are accomplished naturally. This is not the case with the Xybernaut. The body of the Xybernaut is too wide and cumbersome. When worn by the user, the Xybernaut's width prevents the performance of natural actions such as kneeling, rolling, and lying in the prone position.

Human Computer Interaction (HCI) with the Via II is dramatically closer to the familiar PC environment of a laptop or desktop. The Xybernaut's primary input device is a touch-pad pointer located on top of the main console. This is not easily operated when the Xybernaut is worn by the user. The Via II's primary interface is pen based on a 6.5" pen-tablet screen. The user's interface is much closer to an ordinary PC experience while the Xybernaut's Head Mounted Display (HMD) is distracting and bulky. Ultimately, the Via II is much better suited for the tactical environment.

2. It has all the necessary peripherals: audio and microphone jacks, two PCMCIA slots, and a USB port as well.
3. The pen tablet is a 6.5" diagonal color flat panel display. Resolution is 640x480. The screen is resistive and can either be operated by a pen stylus or by touch. The pen tablet also contains controls for brightness, contrast, left and right mouse buttons.
4. While the Via II is equipped with 64MB of RAM, a 180 MHz processor and 3.2 GB hard drive space, it is out-classed by the Xybernaut. However,

Xybernaut's added performance translates to a significantly larger core unit and overall product. This is attributed to the Intel processor. The size and heat sink of the larger Intel chip lead to the bulkier core unit. The Via II's Cyrix processor is thinner than the Intel chip and consequently generates less heat and requires less area within the core unit. Inevitably, the Via II's ergonomics and HCI are so well suited to the tactical environment that a certain degree of performance reduction is acceptable.

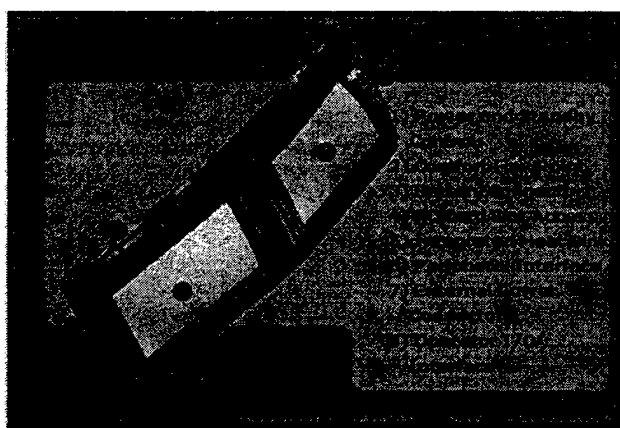

Figure 3.1 The Via II PC Wearable Computer.

2. Digital Video Camera

Recently, digital video cameras have become popular in a variety of settings. Particularly in the motion picture industry, George Lucas has achieved an amazing body of work using digital video. Combined with the power of processing speeds of computers today, the digital video format provides flexibility for commercial and consumer users alike. Digital video cameras have been developed by many manufacturers. Although most handheld digital video cameras differ slightly, the selection within this proof-of-concept is directed to more general issues. Handheld or helmet mounted? Viewfinder versus Liquid Crystal Display (LCD) screen? The

differentiating factors that were examined between potential camera candidates were mainly with the mission constraints in mind.

a. Minimum Requirements

During the analysis of the requirements, the minimum capabilities were determined by establishing what functionality was required to perform the proof-of-concept. The following capabilities are required for the digital video cameras:

1. It must have a night capability. The clandestine nature inherent in nighttime operations makes the requirement for night vision first and foremost for the camera. The ability for the camera to accept peripheral scopes and/or lenses is critical to the VIEW prototype. A lens ring with internal threads would accommodate the night vision device for the VIEW apparatus.
2. It must interface with the WearComp. Either through a USB port or through a PCMCIA slot of the Via II wearable.
3. It must be handheld in order to permit the user to quickly focus attention to a particular target or location. A helmet or shoulder mounted camera may cause the user great difficulty in order to accomplish this task. Further, the user must have the ability to focus attention on a specific subject through a LCD or flat panel screen. This permits a Marine from solely fixing his attention to the viewfinder. In a tactical environment, many other situational issues forbid a Marine the luxury of staring through a viewfinder. The LCD or flat panel screen allows a Marine the opportunity to quickly ascertain the subject.

4. It must have the capability to auto-zoom in and out of the subject field of view. This permits the user to quickly gain a closer view of a subject or location.

b. Design Selection

During the selection phase, specific features were identified. The identification of features were narrowed down based upon the minimum capability criteria generated during the analysis phase. The two products researched closely after developing the minimum requirements and capabilities were from Sony and Hitachi.

Mfr. Model	Accept Peripheral Night Device	PC Interface	Optical Zoom	Digital Zoom	LCD Screen	Mass (incl. battery)
Sony DSR-PD1	YES	RCA, S-Video	10X	120X	84,480 Dots	Approx. 1.4 lbs. (640 g)
Hitachi MPEG Recorder	NO	RCA, S-Video	3X	6X	61,380 Dots	Approx. 1.2 lbs. (540 g)

Table 3.2 Digital Video Camera Minimum Requirements.

The Sony DSR-PD1 digital video camera was selected for the proof-of-concept (Figure 3.2). The selection was made based upon the following specifications:

1. Since a night capability is central to the VIEW proof-of-concept, the Sony DSR-PD1 quickly became the clear choice over the Hitachi MPEG recorder. The Sony digital camera is equipped with an internally threaded lens ring that accepts a standard "C-mount." This is a standard mount for many types of camera lenses and permits the quick and easy installation of zoom, wide angle, and night devices.

2. Both cameras provided standard RCA and S-Video interface with the Via II PC WearComp.
3. The Sony digital camera simply possesses a better zoom capability than the Hitachi MPEG recorder. The zoom capability is important to the precision of the VIEW apparatus and the proof-of-concept. If the desired subject is to be observed while unnoticed, an enhanced zoom capability is necessary to ensure detection of the reconnaissance team is minimized.
4. Both cameras are handheld. This permits the user to quickly focus attention to a particular subject. Although the Sony weighs slightly more than the Hitachi digital camera, target/subject acquisition is performed more easily with the Sony camera. The larger LCD panel of the Sony camera contains more pixels than the Hitachi. This difference between the two cameras is significant when the user attempts to acquire a particular subject by using the LCD panel in lieu of the viewfinder.

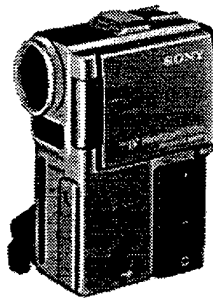

Figure 3.2 The Sony DSR-PD1 Digital Video Camera.

3. Imaging Software

The surging popularity of the Internet has created a demand for software applications that permit users to communicate cheaply. Chat, telephony, and collaboration software is mounting a considerable threat to the well-entrenched telephone industry. With lower rates as an appealing attraction, many Internet users are communicating with friends and family over the Internet. Although there are dozens of companies that offer software (shareware and freeware at times) which permit PC-to-PC chat, the industry is now offering PC-to-internet-to-telephone service as well. [Hill, 1996]

This particular component selection leverages COTS technologies particularly well. An added benefit of COTS software technologies is interoperability. COTS availability in this technology genre is of the variety where integrating like-systems is particularly easy to achieve. Further, using COTS for the system ensures the concept of modularity. This makes replacing obsolete components more judicious rather than discarding the entire system.

The functionality associated with the emerging technologies of collaborative software serves the proof-of-concept objective in this thesis. At a time where no one company may claim dominance of the market, the software is usually inexpensive and easy to acquire. More important, consistent with the constraints defined in the preceding chapter, most versions of collaborative software are capable of sharing video and audio as data between users.

The load on any network multiplies as each user is added. For the purpose of a proof-of-concept, however, this thesis is interested in achieving a peer-to-peer connection only. This permits the Marine transmitting the video image and audio to share data with

the receiver, who assimilates the video and audio data via the collaborative software being used by both parties.

While multi-user scenarios will likely exist in the real-world application of VIEW, the imaging software evaluated for the proof-of-concept will only consider the peer-to-peer connection between a sender and receiver of video and audio data.

a. Minimum Requirements

During the analysis of the requirements, the minimum capabilities were determined by establishing what functionality was required to perform the proof-of-concept. The following capabilities are required for the imaging software:

1. It must be capable of operating within the popular operating systems of Windows 95/98, Windows NT, Unix, and Linux. This ensures compatibility with most desktop PC's and the Via II PC WearComp.
2. It must allow for both video and audio sharing. The software must take advantage of transmission of both media from sender to receiver and back.
3. It must allow options for the trade-off of better resolution at the cost of frame rate reduction. Additionally, the reverse holds true. This performance enhancing option will permit the user to manipulate the priority of media transmission in the event that audio or video becomes more important to the specific application within the mission parameters.
4. As part of the proof-of-concept demonstration, the imaging software must allow for a peer-to-peer connection between two users with Internet Protocol (IP) addresses. This will permit evaluation of the software and the peer-to-peer connection rather than the complexity associated with Internet congestion.

5. The software must be compatible with the hardware being used.

Specifically, the software must be capable of operating within both the Via II PC WearComp (Sender) and an ordinary desktop PC (Receiver).

b. Design Selection

During the selection phase, specific features were identified. The identification of features was narrowed down based upon the minimum capability criteria generated during the analysis phase. The two products researched closely after developing the minimum requirements and capabilities were Smith Micro Internet Comm Suite (ICS) and Microsoft NetMeeting.

Product	OS	Video and Audio Sharing	Resolution vs. Frame Rate	Peer-to-Peer	Software and Hardware Compatibility
Internet Comm Suite	Win 95/98	YES	YES	YES	NO
Microsoft NetMeeting	Win 95/98	YES	YES	YES	YES

Table 3.3 Imaging Software Minimum Requirements.

Microsoft NetMeeting was selected for the proof-of-concept (Figure 3.3).

The selection was made based upon the following specifications:

1. Both software conferencing clients permit audio and video sharing among chat, whiteboard, and more collaboration tools. Further, both run within the Windows 95/98 OS and offer similar performance features that trade off resolution for frame rate speed.
2. Microsoft NetMeeting is a software conferencing client capable of operating within any Windows environment. The industry-wide

acceptance of the Windows operating system(s) has resulted in total hardware compatibility. Specifically, Microsoft NetMeeting can run on any processor. Internet Comm Suite on the other hand, has great difficulty running on the Via II PC. The reason for the hardware/software incompatibility between Via and Internet Comm Suite is the Cyrix processor. The Cyrix Central Processing Unit (CPU) handles floating point processing slowly. Internet Comm Suite can run on a Cyrix CPU, but the hardware could not process video and audio together. Sound was especially difficult to deal with when running Internet Comm Suite. Within Internet Comm Suite, the audio Coding/Encoding (Codec) is making use of the floating-point calculations. Therefore, the processors that do not have optimized support for this mode need more time and resources to accomplish the same task. In one test, Smith Micro compared the CPU usage for the same amount of audio packets that were encoded:

Pentium II 200 used 13%

Cyrix 233MX used 67%

AMD K6-200 used 27%

[Smith Micro, 1999]

3. Internet Comm Suite can usually accommodate a peer-to-peer connection, however, due to the Cyrix processor incompatibility, the peer-to-peer connection can not be achieved consistently. NetMeeting on the other hand, can achieve a peer-to-peer connection between any two PC's running any processor.

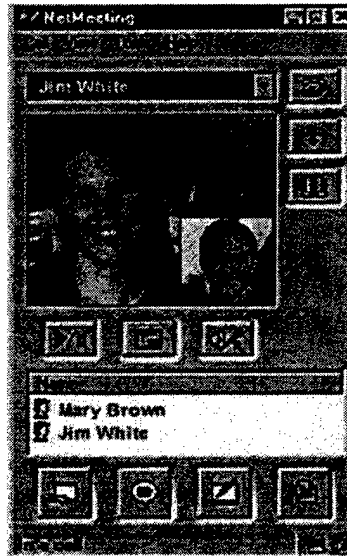

Figure 3.3 Microsoft NetMeeting (3.0) Software Conferencing Client.

4. Night Imaging Device

Units that can operate effectively during hours of darkness or periods of reduced visibility often gain significant advantage over their opponent. Reduced visibility can make the simplest of tasks difficult to accomplish. This obvious disadvantage can be turned on its head and used to our advantage by a commander whose forces are trained, equipped, able, and willing to operate at night. [MCDP 1-3, 1997]

Night operations can produce great gains against a force that cannot or will not operate at night. Operating during periods of reduced visibility creates tempo by adding another 10 to 12 hours to the day for fighting. The psychological impact of night fighting is also great and can produce significant rewards. [MCDP 1-3, 1997]

The advantages are clear; night operations can provide rewards in tempo, morale, and success in operations. Through stealth, surprise, and the psychological impact, the night capability is crucial to the VIEW proof-of-concept.

In collaboration with the Marine Corps Warfighting Lab (MCWL), the B.E. Meyers Dark Invader "OWL" 3rd Generation Multi-Purpose Pocket Scope was used for demonstrating a night capability of the VIEW proof-of-concept. Research previously

conducted by the MCWL revealed the B.E. Meyers corporation had recently manufactured a C-mount for the Sony DSR-PD1 digital camera. The Sony video camera is equipped with an internally threaded lens ring, which accepts the standard C-mount. This is a standard mount for many types of camera lenses and permits for easy installation of zoom, wide angle and night devices.

The B.E. Meyers Dark Invader 3rd Generation Multi-Purpose Pocket Scope (Figure 3.4) or "OWL," is a high resolution system that provides better than 500% increase in low-light sensitivity and better than five times the tube life of 2nd generation imaging system. The OWL is compact, light, and ruggedized. It is powered by two economical "N" cell batteries. The OWL attaches quickly to the Sony Video Camera through the C-mount and a mounting bracket. A "butterfly" nut and a standard 1/4" camera screw can be installed or removed in a matter of seconds.



Figure 3.4 B.E. Meyers Dark Invader OWL.

The OWL adds 18 ounces to the original weight of the Sony Video Camera (1.4 lbs.), bringing the total weight of the Sony/OWL combination (Figure 3.5) to approximately 2.5 lbs. The configured system achieves a night capability with a resultant 120:1 zoom ratio. Through the auto-zoom feature of the Sony Digital Camera, target

acquisition is fast, yet there is room for improvement with respect to accuracy in acquiring a subject.

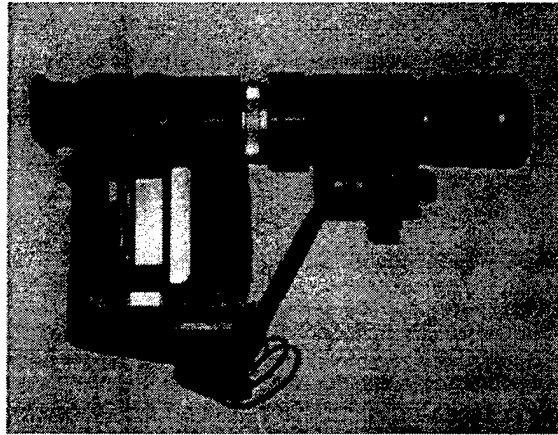

Figure 3.5 Sony/OWL Integration.

5. Wireless LAN Cards

A wireless communications platform is deemed necessary in order to remain consistent with a human factors approach for a lightweight man-portable suite of equipment solution within the VIEW proof-of-concept.

Acting as a surrogate communications suite to a future SATCOM connection (i.e.: Teledesic), the bandwidth offered by today's wireless LAN card technologies is comparable to the fast approaching broadband medium.

The two wireless LAN cards evaluated were Lucent Technologies WaveLan and the Aironet PC 4800. A key difference between the two cards tested is adherence to the wireless LAN standards as defined by the Institute of Electrical and Electronics Engineers (IEEE). The 802.11 standard ensures multi-vendor interoperability and as a result, has become widely accepted by most manufacturers.

The Lucent WaveLan card (Figure 3.6) uses a Direct Sequence Spread Spectrum (QPSK) modulation technique which is fully 802.11 compliant, and offers a data rate transfer of up to 2 Mega Bits Per Second (Mbps).

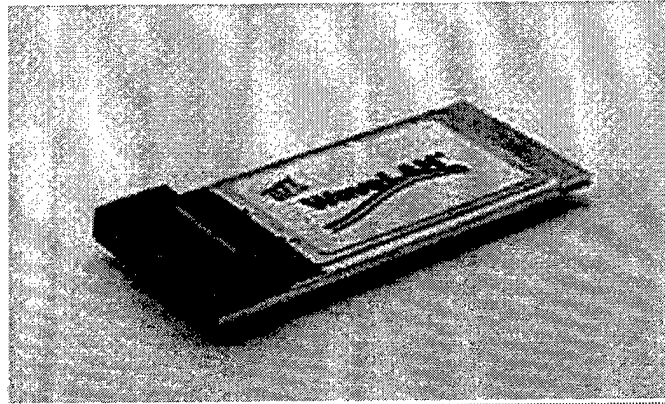

Figure 3.6 Lucent's WaveLan IEEE 802.11 LAN Card.

The Aironet PC 4800 Turbo DS card (Figure 3.7) tested uses a variety of modulation techniques including QPSK and Complementary Code Keying (CCK). Through the use of the IEEE 802.11 standard QPSK modulation technique, the Aironet PC 4800 card achieves interoperability with other vendors. On the other hand, the Aironet card also offers the option of an 11 Mbps data rate. The dramatically higher data rate is achieved through the use of the CCK modulation technique that is designed to the proposed specifications of the new 802.11 IEEE standard for data rates higher than 2 Mbps.

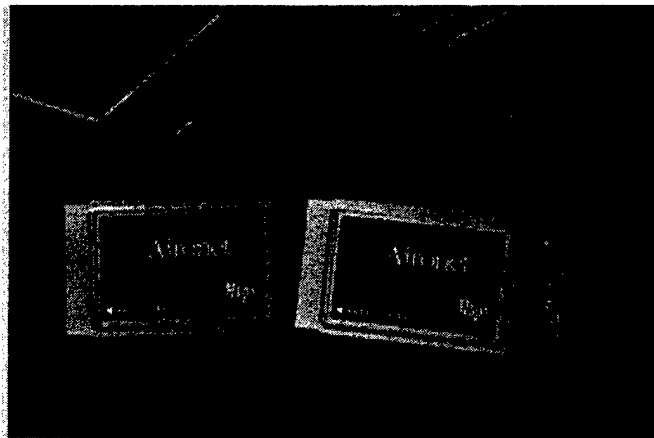

Figure 3.7 Aironet's PC 4800 Turbo DS LAN Cards.

Since the wireless LAN communications suite is a surrogate platform, the VIEW proof-of-concept is primarily interested in determining the data transfer rate or throughput necessary for a variety of video resolutions. For this reason, the Aironet PC 4800 LAN card was chosen as the wireless solution in the VIEW system. Since the Aironet card is 802.11 compliant up to 2 Mbps, testing could be conducted on a Lucent Access Point. Conversely, by operating the PC 4800 LAN card in Ad-Hoc mode, a strict peer-to-peer connection could be achieved using the CCK modulation technique. This permits higher data rates than 2 Mbps and may yield a higher throughput between the VIEW apparatus and the receiving station. Data analysis of throughput rates at varying resolutions are detailed in Chapter V.

6. Cabling and Connectors

In addition to ensuring each component of the VIEW system was compatible, cabling and connectivity also remained an important issue. Specifically, the Via II PC offered the most versatile integration options. Two type II PCMCIA slots and a USB port offered connectivity to the video camera.

With one PCMCIA slot dedicated to the wireless communication of the WearComp to the receiving station, the USB port seemed an ideal solution for integrating the video camera. A solution was found through the use of the Nagatech USB Live video capture adapter.

The Nagatech USB Live video capture adapter (Figure 3.8) offers an RCA cable connectivity from the video camera's output to the WearComp through the USB port.

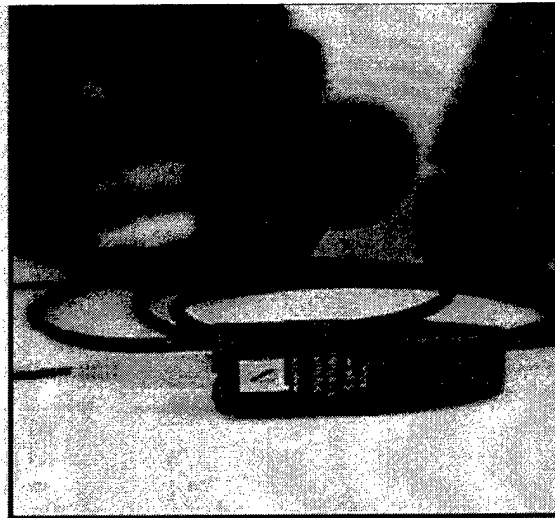

Figure 3.8 Nagatech's USB Live Video Capture Adapter.

However, shortly after the Via II PC's arrival, early tests revealed the USB port was inoperable. When technical support technicians at Via Inc., confirmed a system Basic Input Output System (BIOS) incompatibility, an alternative solution had to be developed.

Since Nagatech Inc. offered numerous interface options for video applications, another solution was quickly found. Nagatech's Notebook TV Kit permits the interface of a video camera and a PC through a PCMCIA card. With two PCMCIA slots available in the Via II PC, Nagatech's Notebook TV (Figure 3.9) is the ideal alternative solution for the VIEW proof-of-concept.

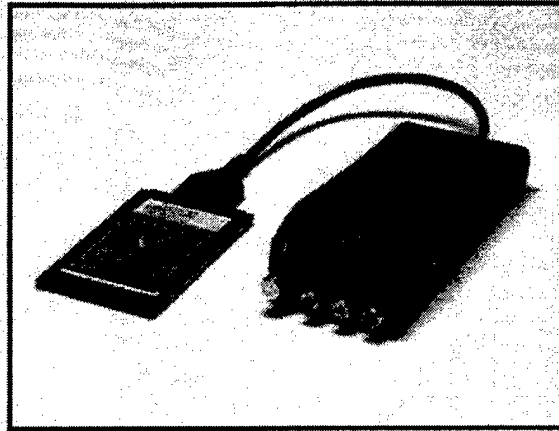

Figure 3.9 Nagatech's Notebook TV Kit.

Assembly of the VIEW proof-of-concept system is complete. A graphic representation of the system is depicted in Figure 3.10.

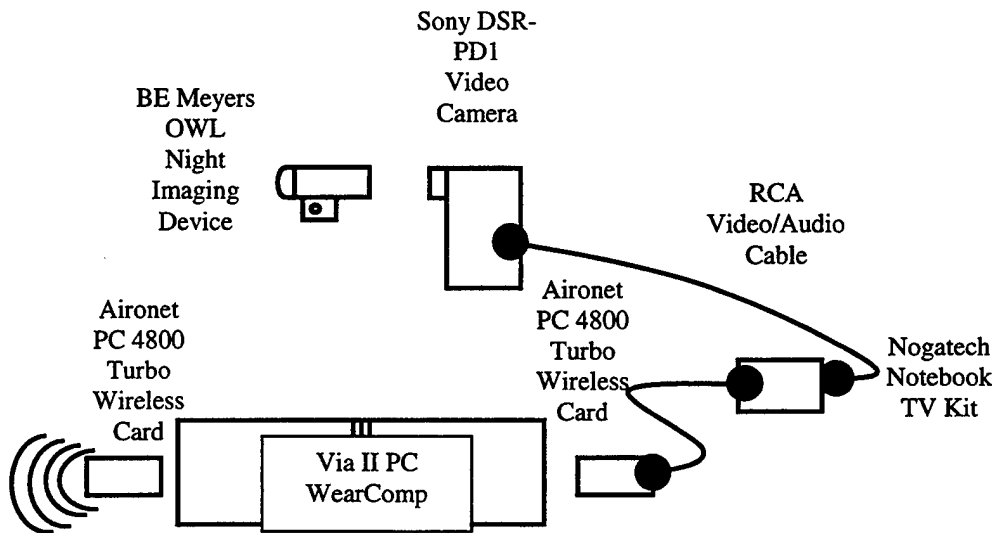

Figure 3.10 The VIEW System Diagram.

D. SUMMARY

By leveraging COTS technologies and employing the concept of modularity in the system design, replacing individual components of the system is a practical alternative to replacing the entire system with the advent of inevitable technological advances.

This Chapter outlined the methodology used in determining a prototype suite of equipment for the proof-of-concept demonstration. The minimum requirements for each component were determined and from those criteria the following components were selected and are displayed in Table 3.4.

Component	Manufacturer/Model	Price
Wearable Computer	Via II PC	\$5,879
Digital Video Camera	Sony DSR-PD1	\$0 (Donated by MCWL)
Imaging Software	Microsoft NetMeeting	\$0 (Freeware)
Night Imaging Device	B.E. Meyers OWL	\$0 (Donated by MCWL)
Wireless LAN Cards	Aironet PC 4800 Turbo	\$1,190
Cabling and Connectors	Nogatech Notebook TV Kit	\$200

Table 3.4 The VIEW Prototype Equipment Suite.

IV. EXAMPLE OF A RECONNAISSANCE MISSION USING VIEW

A. INTRODUCTION

However absorbed a commander may be in the elaboration of his own thoughts, it is sometimes necessary to take the enemy into consideration.

Winston Churchill

This chapter provides a portrayal of a fictional deep reconnaissance mission. It provides a scenario to demonstrate an advanced prototype suite of equipment with similar components to those selected in Chapter III.

The depiction of a Marine manipulating such a device is demonstrated within this chapter in order to highlight the advantages of COTS technologies, system modularity, and ease of use. The scenario poses a potential mission and describes a possible implementation of the VIEW prototype.

B. FICTIONAL SCENARIO

1. Background

There have been growing concerns that the historically aggressive, Patami Republic has been engaged in developing the means to deliver chemical and biological weapons to its neighbors. Nearing United Nations Security Council deadlines, the theater CINC has been directed by the Chairman of the Joint Chiefs to ascertain the location of the weapons manufacturing plants in question.

Routinely used intelligence sources have revealed one suspect factory is located just ten miles from the coastline. The CINC has ordered the MEU commander already in-theater, to confirm what satellite imagery suggests.

The MEU commander delivers his intent to the staff and the ForceRecon platoon commander. Captain Obie, the ForceRecon platoon commander decides to insert one team and because of the strategic implications of this mission, he will accompany the team himself. The team is equipped with a VIEW apparatus which transmits real-time images to the Reconnaissance Operations Center (ROC) aboard the LHA. The ROC is attached to the MEU S-2. It is here, where the MEU S-2 and MEU Executive Officer (XO) are seated and intently viewing the transmissions of the teams. The Amphibious Readiness Group (ARG) is just over the horizon.

2. The Mission

The Marines check over their gear, board the helicopter, and the mission is underway. Under the cover of darkness, the ForceRecon team is inserted at a remote beach approximately ten miles from the objective.

The apparatus has evolved quite a bit since it was first fielded. The hand-held camera is now lighter and smaller. The night vision device, attached to the camera via a standard c-mount, is also more compact and offers a dramatic improvement over the 3rd generation night vision device.

The camera's controls are minimal, simple and completely functional. Video is easily disabled through the flip of a toggle. This quickly interrupts power to the camera and pauses the transmission of video packets through the network. The auto-zoom is operated by a large sliding toggle, while the ability to switch on the infrared capability is also easily achieved merely by flipping a switch on the side of the night vision tube's outer casing.

The headset consists of an earpiece and flexible microphone. The cable connecting the headset to the WearComp runs down the back of the neck and connects to

the VIEW system main body. Similar to the camera, audio packet transmission can be halted merely by flipping a switch at the base of the headset. This permits the user to devote nearly all of the bandwidth available to video packet transmission.

The camera is connected to the WearComp via a cable, which also runs down the back of the neck connecting to the main body of the VIEW apparatus. The WearComp, transmitter, receiver, and GPS device are each weather resistant and neatly tucked away into the ruggedized VIEW outer casing which is worn in the small of the back just above the hips. This permits the user freedom of movement and remains secure while the Marine bends, jumps, or runs. The cables, connectors, and other external items are flexible and integration with the VIEW main body has been carefully designed through a human factors approach as to allow an ergonomically sound Human Computer Interaction (HCI).

User interface is achieved on a standard pen-based touch screen that slides into the recessed slot of the ruggedized outer casing. The flat panel screen is compact, measuring approximately 6" diagonally and has also been ruggedized. The screen is touch resistant and can respond to the user's finger in case the stylus is lost, damaged, or misplaced.

Power is supplied to all components of the VIEW apparatus by a central battery power source. The batteries are rechargeable lithium ion's. There are two slots where batteries are inserted and they are located on the under-side of the VIEW outer casing where they snap into place with a protective retainer clip. Each battery can power the system for approximately two hours of continuous use. However, battery performance is relative; if the camera's auto-zoom feature is used extensively, battery consumption

increases dramatically. The dozen fully charged batteries are distributed among the team and can be hot-swapped at any time.

The 20-watt antenna is mounted on the side of the VIEW outer casing. The flexible but durable antenna transmits and receives signals from a relay station that is located aboard a rigid raider craft just a few miles off-shore. From there, signal strength is boosted and sent to the shipboard antenna of the LHA, where the visual images and other data transmitted by the team are received by the MEU S-2.

Corporal Look is a member of the ForceRecon team and is responsible for transmitting all images which are encountered by his team that may be deemed as critical intelligence. As the helicopter nears the landing zone Corporal Look powers on the VIEW apparatus, checks his headset is snug, and bends the flexible microphone closer to his mouth. He manipulates the WearComp's touch screen with his pen-stylus and initiates the collaborative software; he slides the flat panel touch screen back into the VIEW outer casing slot. Through a 256-bit encryption standard, all three nodes in the VIEW network achieve a secure link.

The helicopter has landed, Corporal Look flips the switch at the base of his headset. This activates his microphone and earpiece, and establishes a voice connection with the S-2 aboard ship. As his team disperses and quickly finds cover, Corporal Look decides to check his system monitor. He again removes the flat panel touch screen from the VIEW system's main body, and observes he is currently transmitting audio and GPS coordinates. The S-2 confirms, there is no need to begin transmitting video packets until he nears the objective at the 2nd phase line, a few miles from the suspect weapons facility. Corporal Look returns the flat panel screen to the VIEW main body.

As the team nears its 2nd phase line, tension rises. There is more "enemy" activity in this area and seems to be increasing as the team nears the objective. As instructed, Corporal Look now powers on the camera. The S-2 aboard the ARG confirms a steady video stream, and Corporal Look mutes his microphone. By halting audio transmission the performance transfer of live video is optimized. At the same time, Corporal Look remains in contact with the S-2 as he can still receive audio. The night vision device and auto-focusing lens constantly adjust to capture the images before Corporal Look.

Corporal Look observes: "This VIEW apparatus is less bulky than some of the VHF and UHF radios I've carried!" Captain Obie, smirks and notes that the team has arrived at the perimeter of the compound which contains the factory in question.

The S-2 is oriented on Corporal Look's location, which is provided by the GPS device. Through the observation of Corporal Look's video transmission, the S-2 compares the three day old satellite images and instructs Corporal Look to acquire the missiles inside the facility at the south east portion of the perimeter. Using the collaborative software, the S-2 expands the image resolution at the receiving node and quickly focuses on the missiles in question. By maintaining audio contact with Corporal Look, the S-2 instructs him to acquire specific subjects while recording the digital video images, audio, and the entire mission sequence at the receiving node aboard the LHA.

The S-2 can also freeze any one particular frame transmitted by Corporal Look. The S-2 can then quickly compare the recently transmitted images to the three-day-old satellite images already in-hand. By observing land features and adjacent buildings, the S-2 decides that the plant is one in the same as the plant on the satellite photography.

A distinct, low toned beep begins emitting into the headset via the WearComp, signaling a nearly discharged battery. The VIEW apparatus central power management

feature instantly begins consuming battery power from the remaining lithium ion battery already inserted in the second slot. Corporal Look reaches inside his cargo pocket of his camouflage utilities and after removing the discharged battery from the first slot, he inserts a fully charged lithium ion into the empty first slot. He clips the retaining bracket over the battery. As the clip snaps into place, he maintains his focus on the missiles.

At the same time, Corporal Look can easily choose to activate audio once again. Through manipulation of the VIEW components, Corporal Look has learned to use the system effectively for each mission. Corporal Look notes that his adeptness with the lightweight camera has progressed significantly. The countless hours of hot swapping batteries with one hand in a dark room have paid off. He always laughed to himself when he thought of this muscle-memorization technique; similar to methods employed by the "old Corps" Marines who would practice field stripping a rifle or pistol in complete darkness.

The XO, now jubilant that the mission is complete, directs Captain Obie to return to the coast where the team will be extracted. Captain Obie relays the order and the team begins to carefully pull back. The video stream is interrupted and the team is tracked closely by the S-2 in the ROC via the GPS and audio data transmitted by Corporal Look.

C. SUMMARY

The last images viewed by the S-2 and the XO are of the helicopter approaching the landing zone. Colonel Frank enters the ROC and confers with the XO and the S-2. He is briefed that the mission was a complete success and the Marines are on their way back to the ship. He studies the images and agrees that the two plants are one in the same.

The MEU commander now holds critical intelligence of the situation that would not have been had without the VIEW apparatus. The Colonel scrambles his staff into action and orders a flash message released to the CINC operations center right away. The message is sent within minutes and informs the CINC of the new evidence. The precision information gathering capability of the VIEW apparatus proves an invaluable technological tool once again.

THIS PAGE INTENTIONALLY LEFT BLANK

V. IMPLEMENTATION AND DATA ANALYSIS

A. INTRODUCTION

...We will explore ways in which we might reshape our MAGTFs to increase their combat power, operational versatility, utility, and deployability. Concurrent with our focus for the future, we must develop intermediate initiatives within the framework of existing technologies to ensure that our current capabilities remain relevant. This will shorten the bridge to the next generation.

General James L. Jones, 32nd Commandant of the Marine Corps

A reconnaissance team, as described in the scenario from Chapter 4, conducted a ground-reconnaissance mission. The team's mission was to confirm the location and contents of a suspected chemical and biological weapons production facility. The information transmitted from the team assisted the MEU Commander in his decision-making capability. He was able to quickly assimilate the intelligence gathered from the Recon team to make a faster, more informed decision. In turn, the MEU Commander immediately informs the CINC, and prepares the MEU for potential follow-on missions well before the Recon team returns from the ground reconnaissance mission.

This chapter will provide a depiction of the implementation of the prototype suite of equipment and will conclude with the analysis of the data generated by the prototype.

B. IMPLEMENTATION

1. Initial Preparation for the Scenario

The VIEW prototype was designed to be a man-portable solution. It is fairly compact and lightweight, with the intention of not interfering, hindering, or constricting the movements of the Marine. The entire suite of equipment was designed to be carried by one individual as a complement to the Marine's 782 gear (cartridge belt and H-

harness). The WearComp, pen tablet, video capture adapter, and batteries are all carried on a belt that has pockets to accommodate the items. The placement of the belt is adjusted to the Marine's own comfort allowing maximum flexibility and minimum obtrusiveness. The video camera and the night vision device would be carried in the Marine's A.L.I.C.E. pack until ready for use.

2. The Order, Movement, and Communication

After the reconnaissance team has received its mission from the unit commander, they will proceed to the objective. Upon arrival at the objective, the team will establish voice communications by means of organic radio assets, if they had not done so prior to their arrival.

The Marine with VIEW will power-up the system, select the Microsoft NetMeeting icon from the Windows user interface, and establish a TCP/IP connection by placing a call with the Microsoft NetMeeting software application (Figure 5.1).



Figure 5.1 Establishing a TCP/IP Connection.

The IP address(es) necessary for the connection were already entered into the system prior to mission launch. To place a call by using the TCP/IP protocol, the Marine would first select the *Call* button from the Toolbar Menu (Figure 5.2) and then select the desired destination IP address (Figure 5.3) from the dialog box that pops up. Upon establishing a connection, voice communications over the circuit may occur and data may be transmitted.

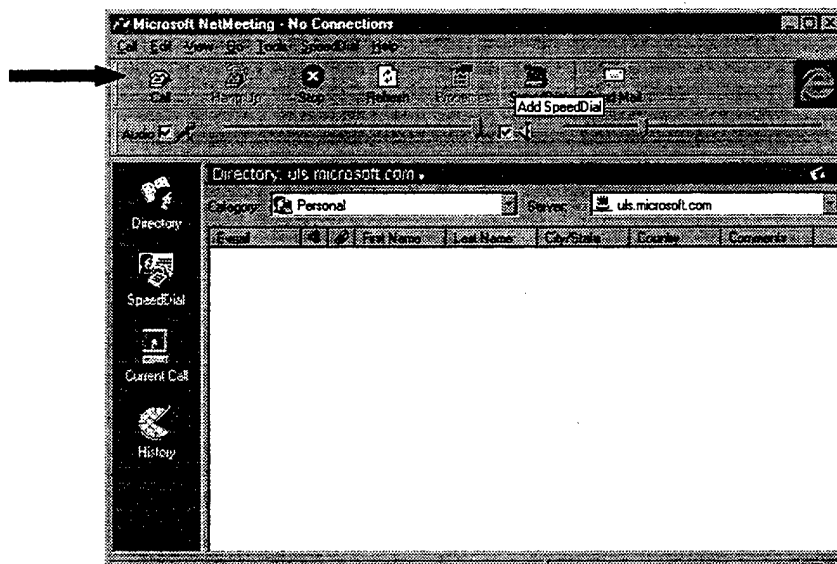

Figure 5.2 The "Call" Button in the NetMeeting User Interface.

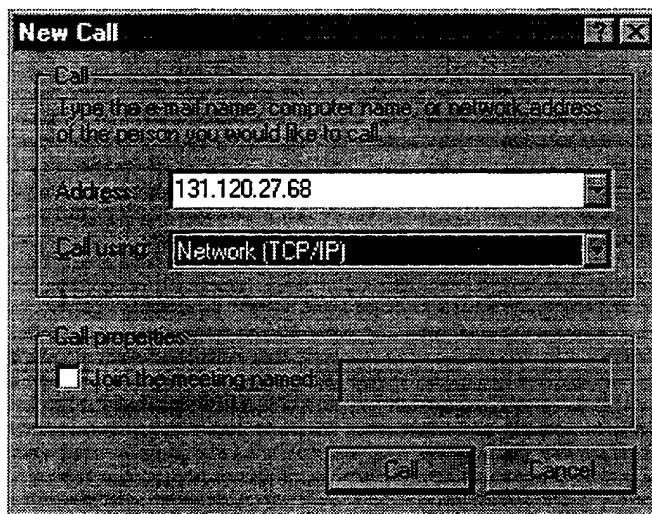

Figure 5.3 The Address Dialog Box.

3. Capture of Digital Video Imagery

The Marine employing the VIEW system will continue the video reconnaissance sequence by connecting the video camera to the video capture adapter on the belt by means of an RCA cable. The Marine then turns on the power to the camera and begins to collect the video imagery of the objective. The Marine is provided immediate feedback from the camera by using its LCD to view the images (Figure 5.4). This capability allows the vision of the Marine to be less encumbered than acquiring a subject through the camera's viewfinder.



Figure 5.4 Using the Video Camera LCD Screen.

4. Video Imagery Under the Cover of Darkness

Night operations can produce great gains against a force that cannot or will not operate at night. Operating during periods of reduced visibility creates tempo by adding another 10 to 12 hours to the day for reconnaissance and surveillance.

The video camera is equipped with an internally threaded lens ring that accepts the standard C-mount, permitting for easy installation of zoom, wide angle and night devices. The night vision scope attaches quickly to the video camera through the C-mount and a mounting bracket. A "butterfly" nut and a standard 1/4" camera screw can be installed or removed in a matter of seconds by the Marine employing VIEW (Figure 5.5), and may be accomplished even in the dark.



Figure 5.5 Mounting the Night Vision Scope.

5. Receipt and Interpretation of Video Imagery

The streaming video from the Recon team will be received within the Joint Intelligence Center (JIC) located on one of the ships within ARG. A MEU S-2 staff member will operate the receive node of the system and process the video in the appropriate manner. The video data will be saved in file format, forwarded immediately

to the appropriate MEU staff members, and possibly uploaded into other intelligence systems such as the Global Command and Control System (GCCS). The MEU Commanding Officer and his staff members may immediately interpret the visual information provided by the video reconnaissance.

6. Termination of the Connection

When the decision is made to terminate the VIEW connection, the sending node simply selects the *Hang Up* button from the Toolbar Menu within the NetMeeting program. The WearComp may be shut down and the equipment may be disassembled and repacked.

C. DATA ANALYSIS

Although the VIEW prototype used wireless LAN cards as a surrogate for a future broadband communications medium, the Aironet software provided a utility that would allow the data rate of a video transmission to be calculated using the Aironet PC4800 wireless LAN cards. The *Statistics* utility provides real-time, receive and transmit statistics to include: the total number of packets, the number of bytes, and a running-time clock, and more (Figure 5.6).

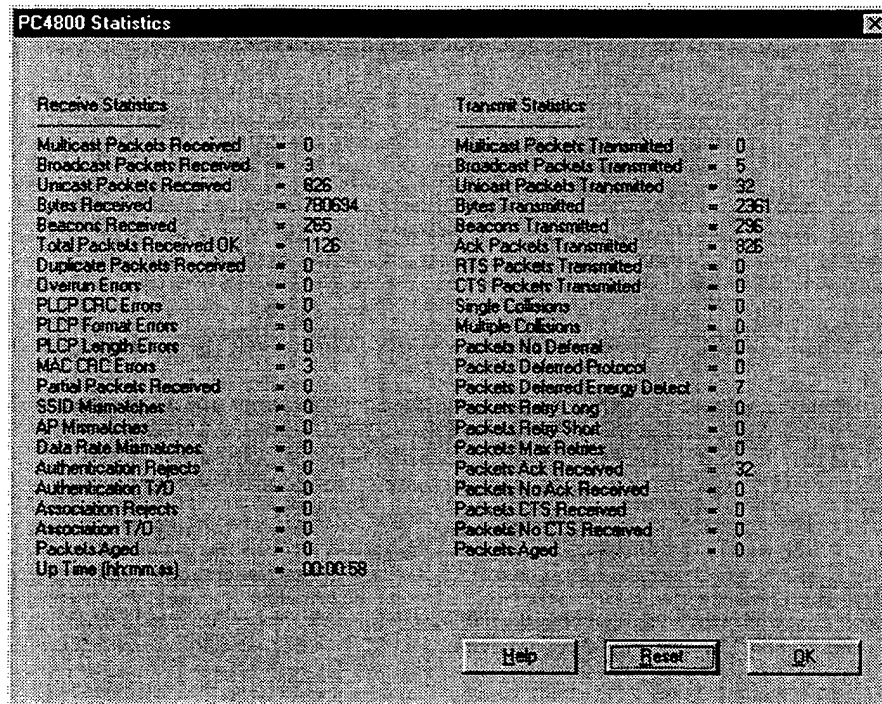

Figure 5.6 Aironet Wireless LAN Statistics Utility Display.

The NetMeeting software offers some video transmission options. Included in these options are three *send image size* choices: small, medium, and large. Also included is a *video quality* option that allows the sender to choose a varying degree of trade-off between the speed of motion video and the quality of the picture (Figure 5.7). Despite extensive attempts to acquire detailed explanations of “image size” and “speed versus quality” characteristics within NetMeeting, the research resulted with no conclusive information. Therefore, educated assumptions were made to explain the lack of detail. The first assumption was that *send image size* pertains to three specific resolutions of the image corresponding to the option chosen. The second assumption was that *video quality* pertains to the number of frames dropped during a transmission. Choosing the “speed” option would allow more frames to drop, increasing the speed of transmission, yet decreasing the quality of the video. Choosing the “quality” option would drop less

frames and improve the quality of the video, yet increase the time required for transmission.

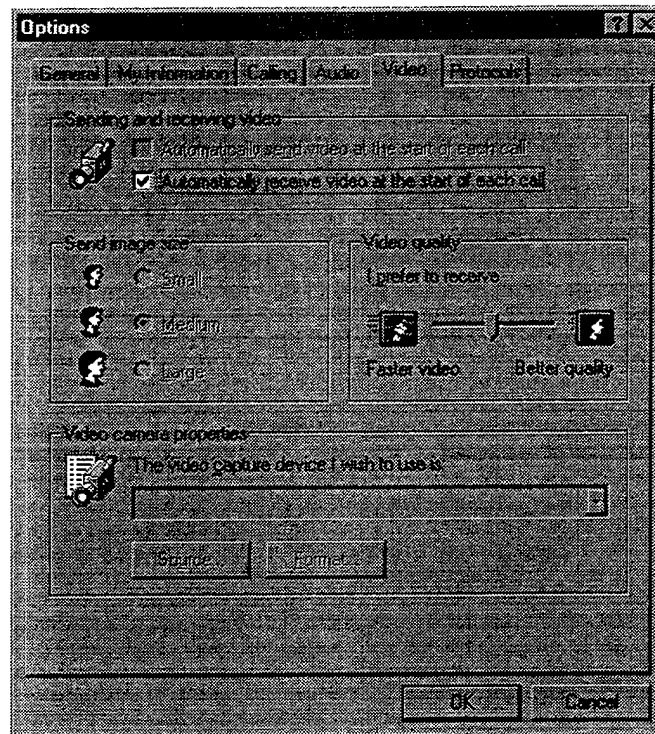

Figure 5.7 NetMeeting Video Options.

The prototype test plan consisted of calculating the average data rate, in kilobits-per-second, for the transmission of a sixty-second video clip. Nine tests were conducted using nine separate video transmission options in NetMeeting, each using a unique combination of *send image size* and *video quality*. The video clip used in each test was a pre-recorded tape played from the camera to provide consistency in the data transmissions. The actual footage of the clip consisted of a Marine, in limited motion, against a static background. The tests were conducted using Aironet PC4800 wireless LAN cards in *Ad Hoc* mode in order to establish a simple peer-to-peer connection. A peer-to-peer connection was necessary because an Aironet access point was not available for testing. The results are provided in the Table 5.1.

Test	Send Image Size	Video Quality			Data Rate (Kbps)
		Speed		Quality	
1	Small		X		32.35
2	Medium		X		29.91
3	Large		X		107.68
4	Small	X			50.62
5	Medium	X			55.29
6	Large	X			94.95
7	Small			X	47.72
8	Medium			X	57.33
9	Large			X	99.69

Table 5.1 Data Rate Test Results.

The tests revealed three points. First, the data rates produced during each of the nine tests were much lower than expected since the LAN card manufacturer boasts of data rates ranging from 2 Mbps to 11 Mbps. The highest test data rate was approximately 108 Kbps. Second, the data rates are proportional to the *Send Image Size*. And third, the *Video Quality* option does not significantly affect the data rate. The difference between speed and quality ranged from approximately 2Kbps to 8 Kbps.

Despite the lower than expected data rates of the VIEW prototype, it may be argued that there existed a certain amount of subjective quality in the video transmission. Since the wireless LAN produced a viable video transmission and is merely a surrogate

feature, the potential data rate performance of future broadband communication media provides for an optimistic outlook.

D. SUMMARY

Implementation of the VIEW prototype suite of equipment was successful. Digital video imagery could be captured, transmitted, received, and viewed. All of the components were COTS, and they interfaced and performed close to expectations.

This chapter provided a description and a graphical depiction of the implementation of the prototype while in actual use outside of the laboratory setting.

The testing and analysis highlighted three main points concerning the data rates and image characteristics. These main points lead to the consideration of future research in the areas of data compression and alternative broadband media.

The following chapter will address potential improvements to VIEW, issues that the Marine Corps would need to address before acquiring and implementing VIEW, and finally, recommendations and opportunities for future research related to VIEW.

VI. RECOMMENDATIONS

A. INTRODUCTION

The purpose of this chapter is to analyze current technologies and to provide a recommendation for future research. This thesis researched the feasibility of developing and implementing a prototype suite of equipment.

The prototype proposed a solution to enhance the surveillance, reconnaissance, and intelligence sensor capabilities of U. S. Marine Force Reconnaissance units through the use of digital video imagery and wireless communication. It also proposed a solution that leveraged current COTS technologies. This chapter will look beyond the research accomplished by this thesis and discuss possible improvements to the prototype that may already exist or are on the horizon. It will also address areas of concern if the prototype were to be fully implemented by the military. Finally, this chapter will also highlight possible areas of future or follow-up research.

B. IMPROVEMENTS TO THE PROTOTYPE

Technological improvements are happening at a phenomenal pace. According to Moore's Law, the processing power of the personal computer is literally doubling about every 18 months. In addition, companies in the information technology industry follow Davidow's Law, which states that they must strive to obsolesce their own products as rapidly as possible in order to keep their market share. [Lewis, 1997] The requirements for the VIEW prototype were generated during the last quarter of 1998. The requirements evolved into the criteria for the minimum requirements and into individual component selection during the first quarter of 1999. Since the components for the

prototype were decided upon, several technological advancements have now become available that could improve the prototype.

1. Technological Advances

Technological advances have already occurred that could improve the process. Since the purchase of the hardware components for the prototype system, a second-generation Xybernaut MAIV WearComp was marketed with several performance-enhancing features. The new Xybernaut computer provided such wares as a Pentium 233 MMX processor, 128 MB of RAM, a 4.3 GB hard disk, and a pen tablet with 640 x 480 resolution. In terms of performance, the new-generation Xybernaut would greatly exceed the ViaII. Perhaps the only drawback of the new Xybernaut is that it is still relatively large and unwieldy when compared to the ViaII PC. From a human-factors point of view, it is still the less desirable design of the two WearComp alternatives.

Inexpensive video capture software programs are being developed and released at an accelerated pace with ever-increasing capabilities, which will spark numerous opportunities for advancement of the video reconnaissance concept.

2. Integration of Components

Improvement to the prototype could also be achieved through the integration of components. Although modularity provides for a higher degree of extensibility and an evolutionary development of the video imagery architecture, integration of components within the architecture would serve to facilitate the user—specifically the Marine performing the reconnaissance. For instance, if the video camera and the computer were merged into one compact device or if the camera, computer, and broadband radio were all integrated into one user-friendly component, the awkwardness of the prototype could be minimized. There exist devices today that incorporate similar technologies into one

device, such as a cellular phone equipped with a personal computer, allowing for limited computing and connectivity to the Internet. Other examples include the combination of a digital camera and a hand-held personal computer and the integration of a hand-held personal computer with a built-in modem.

The ultimate goal of component integration would be to automate the intelligence reporting process to the maximum extent possible. Through integration, many of the cables and interfaces would be eliminated which, in turn, may reduce the chances of system failure and would make the system easier to manipulate by the individual Marine. The Marine performing the reconnaissance could literally turn the device on and video would automatically stream to the receiving end.

3. Automation of the Process

This section will address potential advances that could automate the reconnaissance reporting process. Automation could be implemented through hardware or software. A hardware solution would be a more functional integration of the prototype components. The WearComp would remain the center of the prototype providing the necessary processing. A hardware solution that would leverage future COTS technologies would be the integration of a built-in broadband modem and a fully functional digital video camera. This future prototype would produce a more compact solution and reduce the amount of necessary human intervention.

However, a more complete automation of the process could be realized through software. Software is already available that integrates such capabilities as GPS, email, and the hand-held personal computer. A logical step for VIEW would be a program that fully automates the video reconnaissance process. The program would be a device manager whose main purpose would be to monitor the status of all the components and

initiate a series of steps upon receipt of an instruction. The following describes how the automation could be implemented using software:

- the Marine would power up the system and boot-up the WearComp.
- Upon the selection of a specific icon from the user interface, the imagery being captured by the camera would be automatically streamed over a broadband pipeline to the receiving end.

The program would eliminate the majority of the human intervention presently necessary with the current prototype.

C. MILITARY IMPLEMENTATION CONCERNS

Before the prototype could be implemented for military use, several key issues must be addressed. The following areas were recognized as concerns, however they were beyond the scope of this thesis.

1. Security

There has never been a more urgent need than there is today for the military to protect the privacy of its information. As technology progresses, the military becomes more dependent on automated information systems and the interconnection of these systems. This rapidly evolving information infrastructure has opened broad avenues for unauthorized access to information, expanding the possibilities for electronic theft, degradation, or damage of data and systems. Information operations, which includes Information Warfare (IW), has become a reality. Threats to information systems must be identified and quickly countered to prevent possible exploitation by an adversary.

The video imagery and textual/audio information being transmitted by the reconnaissance team is generally considered to be classified and should be protected.

A potential solution to the security puzzle is the implementation of Secure Socket Layer (SSL) protocol, a security protocol scheme proposed by Netscape Communications Corporation that provides communications privacy over the Internet. It is a 128-bit, low level encryption scheme used to encrypt transactions in higher-level protocols such as Hypertext Transfer Protocol (HTTP), Network News Transfer Protocol (NNTP) and File Transfer Protocol (FTP). SSL protocol allows client/server applications to communicate in a way that is designed to prevent eavesdropping, tampering, or message forgery. The primary goal of the SSL protocol is to provide privacy and reliability between two applications that are communicating. SSL is composed of two layers. At the lowest level, layered on top of some reliable transport protocol (e.g., Transmission Control Protocol {TCP}), is the SSL record protocol. The SSL record protocol is used for encapsulation of various higher level protocols. One such encapsulated protocol, the SSL handshake protocol, allows the server and client to authenticate each other and to negotiate an encryption algorithm and cryptographic keys before the application protocol transmits or receives its first byte of data. One advantage of SSL is that it is application protocol independent. A higher level protocol can layer on top of the SSL protocol transparently.

The SSL protocol provides connection security that has three basic properties: First, the connection is private. Encryption is used after an initial handshake to define a secret key. Symmetric cryptography is used for data encryption. Second, the peer's identity can be authenticated using asymmetric, or public key, cryptography. And third, the connection is reliable. Message transport includes a message integrity check using a keyed Mandatory Access Control (MAC). Secure hash functions (e.g., SHA, MD5) are used for MAC computations. [Netscape, 1999]

Another potential security solution may be found in SHTTP (Secure HTTP). SHTTP is the scheme proposed by CommerceNet, a coalition of businesses interested in developing the Internet for commercial uses. It is a higher level protocol that only works with the HTTP protocol, but is potentially more extensible than SSL. Currently, SHTTP is implemented for the Open Marketplace server marketed by Open Market, Inc. on the server side, and secure HTTP Mosaic by Enterprise Integration Technologies on the client side. [EIT, 1999]

These possible security solutions are good examples of COTS products that could be incorporated into the VIEW system.

2. Ruggedization

The components used for the prototype were COTS equipment. To provide a reliable solution for the military, the components would need some form of additional protection from the environment and other elements. Ruggedization could entail the hardening of every component such that the system could endure a certain level of impact without hampering the performance of the equipment. Each component could be ruggedized to meet the stringent requirements of the military. However, this would significantly increase the weight and cost of the suite of equipment. It would no longer be a lightweight, low cost solution. Ruggedization may involve a certain degree of weatherproofing to ensure that water and particles do not degrade the equipment prior to a critical mission. Ruggedization could also be as simple as a protective carrying case. The hardened case would surround the components, protecting them from the environment without constricting the Marine's movements.

3. Communication Footprint

The communications medium employed during the VIEW prototype's proof-of-concept was wireless LAN. This medium provides a very limited operating range depending on the environment. The communications medium required for an actual application would need to provide the capability of allowing long-range coverage in excess of ten miles. In addition, the medium would need to cover nearly the entire earth to accommodate the Marines' potential operating environment that may be in any "clime or place."

One solution may be a long-haul broadband system that is mounted on a floating platform. Another solution would be to employ a broadband satellite system such as Teledesic.

The communications medium and equipment would need to be versatile enough to provide the distance required of the reconnaissance team and provide sufficient bandwidth for the transmission of imagery.

4. Integration into Existing Information Systems

The Marine Corps does not need another stovepipe solution. For the prototype to be accepted as a valuable tool for the unit commander, it must be seamlessly integrated into the existing information systems currently being used by the military. The information delivered by the reconnaissance team must be capable of being integrated into existing information systems. The video stream may be downloaded at the receiving end and stored in a standard format such as an Audio Visual Interleave (AVI) file or Moving Pictures Experts Group (MPEG) file and uploaded into the Global Command and Control System (GCCS) which is the current command and control information system being used throughout the Department of Defense. The information would then be in a

usable format that could be viewed by anyone having access to a GCCS terminal. The data could then be further processed, manipulated, and integrated into the overall strategic plan.

5. Improved Optics

For video to be employed as a sensor technology for surveillance, reconnaissance, and intelligence operations, the ability to focus on distant objects, or zoom, is clearly a key requirement. While the Sony DSR-PD1 video camera employed for the VIEW prototype in this thesis boasts a robust 120x digital zoom capability, the optical zoom component only provides 10x magnification, which leaves room for improvement. Ideally, the magnification power of a typical commercial spotting scope should be incorporated into the VIEW prototype capabilities. Many spotting scope products provide magnification in the realm of 45x to 60x and some even boast of 160x magnification. [Eagle Optics, 1999] The inherent benefits that greater optical magnification provides are numerous. They include a greater degree of visual clarity, an extended reconnaissance range of operation, and a measure of safety, in that the Marines could provide observation from a greater distance.

D. FOLLOW-UP RESEARCH

1. Video Compression Technology

Video compression offers another research opportunity related to digital video imagery. While compression technology has existed for many years, and continues to evolve, practical implementations for video have only become possible in the past few years due to the rapid evolution of digital processing technologies. This, in turn, has stimulated new research into scalable video encoding techniques that will allow multiple levels of image quality to be extracted from a single image data stream. Consistent with

Moore's and Davidow's Laws, it is within the realm of possibilities that the processing power required for the decoding of scalable, digital video streams will be universal and inexpensive shortly after the turn of the millennium. Improvements in data compression perform the same function as increases in bit carrying capacity in the communications system—delivery of more bits to the receiving end. In the past decade, increases in communications capacity of several orders of magnitude have occurred.

For the VIEW prototype specifically, research may be conducted to determine whether embedded hardware compression or software compression provides for better performance. This thesis tested a prototype using software compression only.

Research may also be conducted to determine the best format for compression to use. There are proprietary schemes from the earliest days of multimedia such as AVI, Indeo, and QuickTime, which boast compression ratios up to 10:1. Px64 (H.261) format was developed by the Consultative Committee on International Telephony and Telegraphy (CCITT) for video teleconferencing. Px64 seeks to minimize encoding and decoding delay while achieving a fixed data rate. [Kanade, 1999]

In digital telephony, delays larger than a few hundred milliseconds can be very annoying. It does this, in part, by assuming that motion is very limited. Although Px64 can achieve a compression ratio in excess of 100:1, the format sacrifices quality in order to get low latencies. Motion Joint Photographic Experts Group (JPEG) provides another format for video which simply extends the JPEG standard to each frame independently, and as such does not take advantage of interframe correlation to reduce the data rate. Motion JPEG achieves a compression ratio of 20:1. MPEG is the format for compressing video and audio developed by the Motion Picture Experts Group (MPEG) of the International Standards Organization (ISO). There are now three different MPEG

standards that boast compression ratios in excess of 150:1. MPEG-1 was designed for 1.15 Mbps and generally compresses moving images to VHS quality. MPEG-2 (H.262) targets 4 to 9 Mbps and contains many enhancements. [Kanade, 1999] MPEG-2 was chosen by the Digital HDTV Grand Alliance to be the standard for High Definition Television (HDTV). MPEG-4 is a more recent format designed for video telephony.

The formats discussed to this point are all based on the Discrete Cosine Transform (DCT). Some newer techniques, such as wavelet compression and fractal compression, promise higher compression ratios (in excess of 200:1) for comparable quality by replacing the DCT with a different transform. Wavelet compression represents an image in terms of functions called wavelets and computes the wavelet coefficients using the fast wavelet transform. Fractal compression describes a picture in terms of a mathematical process that produces a fractal. Both of these techniques are still image compression techniques that could be applied to individual frames like Motion JPEG. [Kanade, 1999]

Finally, there are streaming file formats such as the Advanced Streaming Format (ASF) which describe how data is organized as it moves across a network, letting users play the file as packets stream in.

2. Broadband Communication Sources

This thesis approached a proof-of-concept for digital video imagery based on the premise that implementation of the prototype would take advantage of the rapidly developing broadband technologies that are emerging. Transmission of video requires relatively more bandwidth when compared to other forms of data transmissions such as email or file transfers. A pipeline in excess of 2 Megabits per second is probably a minimum. In order for the Marine Corps to take advantage of video reconnaissance, a

broadband communications medium must be used. This thesis used a wireless LAN as a surrogate to a broadband network such as a satellite constellation that uses the Ka band (20 to 30 GHz range) of the frequency spectrum.

One broadband alternative is Teledesic. Teledesic is building a global, broadband Internet-in-the-Sky using a constellation of 288 low-Earth-orbit satellites. They boast that their network will be the first to provide affordable, worldwide, "fiber-like" access to communications services such as computer networking, broadband Internet access, high-quality voice and video, and other digital data needs. The system is designed to support millions of simultaneous users, most of which will have two-way connections that provide up to 64 Mbps on the downlink and up to 2 Mbps on the uplink. Higher-speed terminals will offer 64 Mbps or greater of two-way capacity. [Midkiff, 1999] This represents access speeds more than 2,000 times faster than today's standard analog modems. This medium seems to be a plausible option. The trend within the Command, Control, Communications, Computers, Intelligence, Surveillance and Reconnaissance (C4ISR) community favors the increased use of civilian satellite and terminal equipment in order to capitalize on the impending growth of the LEO commercial satellite communications industry. In the Department of Defense, there are programs targeted to swiftly exploit civil satellite and other COTS telecommunications and computer technology, especially for mobile applications.

Another alternative would be a broadband line-of-sight system such as the FoNet VideoBeamer. [FoNet, 1999] VideoBeamer is a broadcast quality, video transmitter/receiver system that is lightweight, portable and universally compatible with conventional video equipment. The system operates in the 300 MHz to 2500 MHz range with multiple power selections from .5 milliWatts up to 20 Watts. The devices are made

to military specifications (Mil Spec) and are weatherproof. The operating range projects a 12-mile radius.

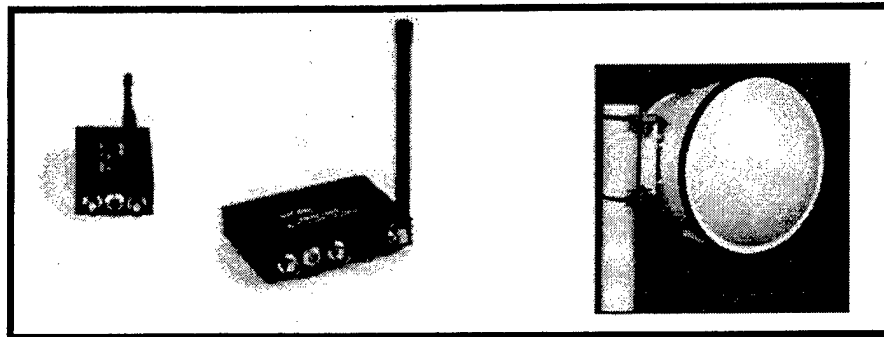

Figure 6.1. FoNet VideoBeamer Receiver/Transmitter System.

Yet another alternative may be to extend the system used to test the VIEW prototype in this thesis by designing an extended tactical wireless LAN using wireless LAN cards and well-placed access points.

These alternatives are but a few of the many broadband alternatives available for trial and implementation.

3. Requirements Analysis for the Broadband radio

If a satellite system such as Teledesic is chosen as the broadband medium, it is probable that a man-pack, portable radio will have to be designed. Although the use of LEO satellites enables the use of small, low-power terminals and antennas, the terminals that are currently being planned for production are rooftop mounted. An opportunity exists for follow-on research into the requirements for a portable broadband SATCOM radio that operates in the Ka band and interfaces with the VIEW system.

4. Optimal Video Capture Software Products

This thesis explored a limited number of the available video capture software products available on the commercial market. A follow-on research project would be to focus solely on the software performance issues, assessing the minimal and optimal

requirements and exploring the alternative software packages available, which meet the desired requirements.

5. Implementation of VIEW Over Viable Broadband Channel

This thesis proved the concept of digital video imagery in a confined range of less than one mile. An extension of this research would be the long-haul implementation of VIEW over one or more of the broadband communication alternative mentioned previously.

6. Implementation of Multiple Nodes

The ultimate digital video imagery system would allow a commander to virtually have his eyes in more than one place simultaneously. If three Marine reconnaissance patrols are employed, the system should allow the Marine commander to see three streaming video pictures on his display at the same time. Conceptually, this should allow a commander to construct a broader picture of the battlespace. This thesis tested only two nodes. Practical implementation of this system would dictate that further research be conducted employing multiple nodes.

7. Receiving Node Requirements Analysis

This thesis focused primarily on the requirements for the mobile or sending node of the system. The requirements for the receiving node must also be addressed. A research opportunity exists in analyzing the requirements in terms of hardware, software, processing, and multimedia storage formats.

8. Integration of Complementary Technologies

The VIEW prototype employed for this thesis leaves much room for improvement as a surveillance, reconnaissance and intelligence tool for the Marine Corps. A research opportunity exists for the creation of a second-generation prototype that integrates

complementary technologies such as the Global Positioning System (GPS) and laser range-finding technology. Extending that concept, software code could be written which bundles a latitude and longitude reading, an offset metric to the object in focus, audio and the video all into one data stream for transmission.

9. Effects of Streaming Video Intelligence on the Traditional Leadership Hierarchy

If video reconnaissance technology is employed in the future, research may be done to determine what effects, if any, this particular technology may have on the top-down military hierarchy. While some say technology can assist in harnessing the combat power of the lower levels of tactics, others argue that the outcome has the potential of erasing a much needed middle layer of experienced captains, majors, and senior enlisted non-commissioned officers. [Garreau, 1999] Although there exists a vast amount of documentation about the effects on the sensing, collection, and dissemination of information in the battlespace, there has been little discussion of the impact of information technologies on command relationships and operational practices within the Marine Corps.

There is evidence from organizations outside of the military that suggests that embracing information technologies drives changes in both process and organization. [Holland, 1999] The most significant change noted was improved worker capability and productivity, leading to the need for fewer managers. The shortening of the hierarchy is already taking place in naval operations since the information available to the on board commander is available to every echelon of leadership up to and including the National Command Authorities. [Holland, 1999] War gaming indicates that the National Command Authorities will micro-manage the forces engaged as a crisis moves to conflict.

Might this paradigm of "tight control through improved technology" rise to existence in the Marine Corps as sensory tools improve? To help answer this question, the Marine reconnaissance unit may be modeled and an answer projected based on the analysis.

10. Security

A final opportunity for research resides in the area of security. Should encryption be executed using hardware or software technologies? And how will the VIEW system be incorporated into the concept of Multilevel Security (MLS)? MLS is a relatively recent concept that has emerged in the Communications Security (COMSEC) field.

As the MLS concept matures, it will assure end-to-end encryption and will enable hosts and users with different levels of security clearance (i.e., Unclassified, Secret and Secret/SCI) to operate in the same network without the fear of electronic security violations. The National Security Agency's (NSA) Multilevel Information System Security Initiative (MISSI) endeavor will provide a multilevel security capability for networked automated systems to achieve a single integrated, consistent security infrastructure for all needs, to include: email, command and control, surveillance, reconnaissance, and intelligence. [C4ISR Handbook, 1998]

Additional research may be conducted on the implementation of the SSL protocol and SHTTP as discussed earlier in this chapter.

E. SUMMARY

This research developed and implemented a proof-of-concept prototype suite of equipment to enhance the surveillance, reconnaissance, and intelligence reporting process. The test of the VIEW prototype using a surrogate communication medium was a success. However, this research should not end with the one success. Advances in

technology will continue to provide new capabilities and additional functionality that will only enhance the performance of this prototype. This chapter concluded with several different research opportunities which could be pursued to further implement the use of digital video imagery into the military.

LIST OF REFERENCES

Aironet Wireless Communications Inc.,
[<http://www.aironet.com/products/pc4800/pc4800.html>]. July 1999.

B.E. Meyers Co.,
[<http://www.bemeyers.com/product.html>]. May 1999.

Chairman of the Joint Chiefs of Staff, *Joint Vision 2010*, Pentagon, Washington, D.C., 1996.

Department of Defense, *Command, Control, Communications, Computers, Intelligence, Surveillance and Reconnaissance (C4ISR) Handbook*, pp.2-91, Washington, D.C., 1998.

Eagle Optics Inc.,
[http://www.eagleoptics.com/eagle/eagle_home.html]. July 1999.

Enterprise Integration Technologies, Inc.,
[<http://www.eit.com>]. July 1999.

FoNet Inc.,
[<http://www.firstlook.net/firstlook.htm>]. July 1999.

Garreau, Joel, "Point Men for a Revolution - Can the Marines Survive a Shift from Platoons to Networks?" *Washington Post*, p. A01, March 6, 1999.

Headquarters, Department of the Army, *Field Manual 5-170 Engineer Reconnaissance*, Washington, D.C., 1998.

Headquarters, United States Army, *Field Manual 34-130 Intelligence Preparation of the Battlefield*, Washington, D.C., 1994.

Headquarters, Department of the Navy, United States Marine Corps, *Marine Corps Doctrinal Publication 6, Command and Control*, Washington, D.C., 1996.

Headquarters, Department of the Navy, United States Marine Corps, *Marine Corps Doctrinal Publication 1-3, Tactics*, Washington, D.C., 1997.

Hill, Jon, "Net2Phone Makes the Call." *PC Magazine*, October 22, 1996.

Holland, W.J., Rear Admiral, U.S. Navy (Retired). "Where Will All the Admirals Go?" *Proceedings*, pp. 36-40, May, 1999.

Kanade, T, "Advances in Cooperative Multi-Sensor Video Surveillance."
[<http://www.ri.cmu.edu/labs/>]. November 1998.

Lewis, T.G., *The Friction Free Economy*, pp. 6-19, HarperCollins Publishers Inc., 1997.

Mann, Steve, "Wearable Computing as means for Personal Empowerment."
[<http://wearcomp.org/wearcompdef.html>]. May 1998.

Marine Corps Warfighting Laboratory, "Urban Warrior Advanced Warfighting Experiment."
[<http://www.mcwl.quantico.usmc.mil/mcwl/uw/index.html>]. March 1999.

Midkiff, Scott F. "Course Outline."
[<http://fiddle.visc.ece.vt.edu/courses/ee4984>]. September 1999.

Microsoft Corp.,
[<http://www.microsoft.com/windows/netmeeting>]. August 1999.

Netscape Communications Corporation,
[<http://home.netscape.com/eng/security/certs.html>]. July 1999.

Nogatech Inc.,
[<http://www.nogatech.com>]. June 1999.

Smith Micro Software, Inc.,
[<http://www.smithmicro.com/techsupport>]. June 1999.

Sony Corp.,
[<http://www.sel.sony.com/SEL/consumer/ss5/office/camcorder/digitalvideoproducts/dcr-pc1.shtml>]. May 1999.

Teledesic LLC.,
[<http://www.teledesic.com/index.htm>]. June 1999.

Via Inc.,
[<http://www.flexipc.com/>]. May 1999.

Zimm, Alan D., CDR, U.S. Navy (Retired). "Human-Centric Warfare," *Proceedings*, pp. 28-31, May 1999.

INITIAL DISTRIBUTION LIST

1. Defense Technical Information Center2
 8725 John J. Kingman Road, Ste 0944
 Fort Belvoir, VA 22060-6218

2. Dudley Knox Library2
 Naval Postgraduate School
 411 Dyer Road
 Monterey, CA 93943-5101

3. Rudy Darken, Ph.D. Code CS/Dr.....1
 Computer Science Department
 Naval Postgraduate School
 Monterey, CA 93943-5000

4. LtCol Terrance C. Brady, Code SM/BA1
 555 Dyer Road, Room 304
 Naval Postgraduate School
 Monterey, CA 93943-5103

5. Director, Marine Corps Warfighting Laboratory1
 MCCDC, Code C52
 3255 Meyers Ave
 Quantico, VA 22134-5130

6. National Reconnaissance Office2
 Kevin G. Donaleski
 14675 Lee Road
 Chantilly, VA 20151-1715

7. Director, Training and Education.....1
 MCCDC, Code C46
 1019 Elliot Road
 Quantico, VA 22134-5027

8. Director, Marine Corps Research Center.....2
 MCCDC, Code C40RC
 2040 Broadway Street
 Quantico, VA 22134-5107

9. Director, Studies and Analysis Division1
 MCCDC, Code C45
 300 Russell Road
 Quantico, VA 22134-5130

- 10. Marine Corps Representative.....1
Naval Postgraduate School
Code 037, Bldg. 234, HA-220
699 Dyer Road
Monterey, CA 93940

- 11. Captain James E. Munroe II.....1
c/o James Munroe, Sr.
4 Kendon Rd.
Pittsford, NY 14534

- 12. Captain Arthur J. Pasagian.....1
c/o Vartkes Pasagian
21-34 Himrod Street
Ridgewood, NY 11385

- 13. Chairman, Code IS.....1
Naval Postgraduate School
Monterey, CA 93943-5103