



**AIAA 98-2887**

**Expected Productivity Benefits Resulting  
from the New Data Acquisition, Processing,  
and Control System for Tunnel 16T at AEDC**

Philip Stich, Dennis Rose, and David Rollins  
Sverdrup Technology, Inc., AEDC Group  
Arnold Engineering Development Center  
Arnold Air Force Base, Tennessee 37389

**DISTRIBUTION STATEMENT A**  
Approved for Public Release  
Distribution Unlimited

19991202 065

**20th Advanced Measurement and  
Ground Testing Technology Conference**  
June 15-18, 1998 / Albuquerque, NM

For permission to copy or republish, contact the American Institute of Aeronautics and Astronautics  
1801 Alexander Bell Drive, Suite 500, Reston, VA 22091

# Expected Productivity Benefits Resulting from the New Data Acquisition, Processing and Control System for Tunnel 16T at AEDC\*

*Philip Stich,<sup>†</sup> Dennis Rose, and David Rollins  
Sverdrup Technology, Inc., AEDC Group  
Arnold Engineering Development Center  
Arnold Air Force Base, Tennessee 37389*

## Abstract

Requirements for large-scale transonic wind tunnel test capability into the next century necessitate that significant sustainment efforts be undertaken for U.S. facilities to maintain reliable and efficient testing services. Many national facilities located at the major NASA centers and the Department of Defense's Arnold Engineering Development Center (AEDC) are in the middle of or preparing for major refurbishment programs. In Fiscal Year 1998, the Propulsion Wind Tunnel (PWT) Facility at AEDC launched a 7-year, \$80M sustainment program which will improve reliability, reduce testing cycle time, reduce the number of operational stationkeepers, and improve the quality of test data in the 16-foot transonic and supersonic wind tunnels. A major part of this program is a total replacement of the data acquisition, processing and control systems in Tunnel 16T. This effort will provide major improvements in productivity of the test process as well as improved reliability and quality of data. This effort, along with ongoing maintenance and improvement projects, will sustain the world-class status of this important development wind tunnel.

## Nomenclature

AEDC Arnold Engineering Development Center  
AMS Asset Management System  
AOH Air-on hours  
ATM Asynchronous Transfer Mode  
CTS Captive Trajectory System  
DAPS Data Acquisition and Processing System

DAS Data Acquisition System  
DDAS Dynamic Data Acquisition System  
DOF Degrees of freedom  
ESP Electronically Scanned Pressure  
FDDI Fiber Distributed Data Interface  
HAAS High-Angle Automated Sting  
LAN Local Area Network  
M Mach number  
MIB Model Installation Building  
NASA National Aeronautics & Space Administration  
PES Plenum Evacuation System  
PLC Programmable Logic Controller  
PSS Pressure Scanning System  
Pt Total pressure  
PWT Propulsion Wind Tunnel  
SDAS Steady-State Data Acquisition System  
TACS Test Article Control System  
TAS Test Analysis System  
4T Four-ft Transonic  
16T Sixteen-ft Transonic  
16S Sixteen-ft Supersonic

## Introduction

A major sustainment program for the 16-ft wind tunnels in the Propulsion Wind Tunnel (PWT) Facility at AEDC has been initiated to maintain the world-class status of this facility for providing critical development data for aerospace programs. A

\* The research reported herein was performed by the Arnold Engineering Development Center (AEDC), Air Force Materiel Command. Work and analysis for this research were performed by personnel of Sverdrup Technology, Inc., AEDC Group, technical services contractor for AEDC. Further reproduction is authorized to satisfy needs of the U. S. Government.

<sup>†</sup> Member, AIAA.

major part of the program scope provides a new data acquisition and processing system with integrated model and automated tunnel controls for Tunnel 16T. This paper provides details of the planned data system and controls improvements and the expected productivity benefits to be realized as a result.

### Facility Description

The AEDC PWT 16-ft Tunnel 16T shown in Fig. 1, is a variable-density, continuous-flow tunnel capable of being operated at Mach numbers from 0.06 to 1.6 and total pressures from 200 to 4,000 psfa with the maximum stagnation pressure a function of Mach number based on available drive power. The tunnel was designed for aeropropulsion testing and hence is equipped with a scavenging system to remove combustion products. The test section is 16-ft square by 40 ft long, and has perforated walls of six-percent porosity as shown in Fig. 2.

The same compressor drive system, consisting of four electric motors totaling 271,000 hp including a 15-percent service factor, is used for either Tunnel 16T or 16S (supersonic circuit). Tunnel pressure level control, air exchange, some exhaust gas scavenging, and Tunnel 16T plenum suction are provided by the Plenum Evacuation System (PES) compressors, totaling 155,000 hp. The Engine Test Facility compressor system is used for scavenging exhaust gases with a high water vapor content. The tunnel air humidity is controlled by dry air supplied from an atmospheric air dryer, a desiccant type which uses silica gel.

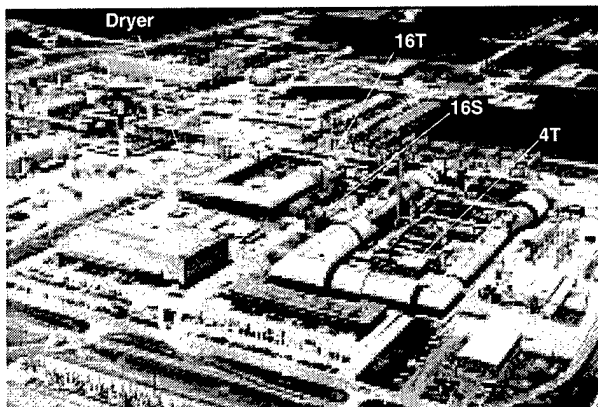

Fig. 1. Aerial view of Propulsion Wind Tunnel Facility at AEDC.



Fig. 2. Tunnel 16T test section.

PWT Tunnels 16T/16S/4T currently employ a system of three Digital Equipment Corporation (DEC) VAX 8650 computers for supervisory control and data/resource management of digital data acquisition, model control, and data processing systems. These systems are connected by Ethernet baseband networks to various nodes associated with each tunnel. One of the VAX 8650 computers is normally used to provide on-line support for 16T/16S tests; another is used to provide on-line support for 4T tests; and the third is used to provide off-line support for a pretest checkout system and other purposes.

### Program Justification

Since the PWT Facility was constructed and commissioned in the 1950's, most of the major systems have not had a significant refurbishment. Piecemeal improvement and modernization efforts have been implemented over the years in an attempt to maintain pace with changing test techniques and data productivity requirements. Tunnel 16T is the highest use wind tunnel, in terms of Air-On-Hours (AOH) at AEDC, and possibly in the nation. Effective maintenance and repair efforts have kept the facility operational and reliable; however, in many cases the limits of the obsolete and

worn-out equipment are becoming evident. In addition, the current and future need for better, more productive and cheaper wind tunnel data require that wind tunnel systems have a much higher level of automation and integration to streamline wind tunnel processes. The Aerodynamics Business Area at AEDC has developed improvement requirements and an investment roadmap to deliver them. The PWT Sustainment Program provides a major boost to achievement of the improvement vision by funding four of the major scope items. Productivity enhancements for the data acquisition, processing, and control system for Tunnel 16T are described in the following sections.

### Data Acquisition and Processing System (DAPS)

The DAPS requirements were derived based on making substantial progress towards realizing

AEDC strategic objectives of reduced cost and cycle time. Major improvements in productivity and reduced cost are forecast for test installation and test execution work phases. Successful implementation will require substantial changes in the current installation and test execution work processes. This will necessitate extensive training in new procedures, certification in specific processes, and potential realignment of personnel.

The Data Acquisition & Processing Systems (DAPS) will be an integration of model data acquisition, model controls, tunnel and plant controls and will be focused on achieving increased productivity with testing in Tunnel 16T. The operational vision is categorized by seven functional areas. These seven areas are shown in Fig. 3. Test-related processes affected include Test Planning, Buildup/Checkout, Real-Time Test Operations, and Post-

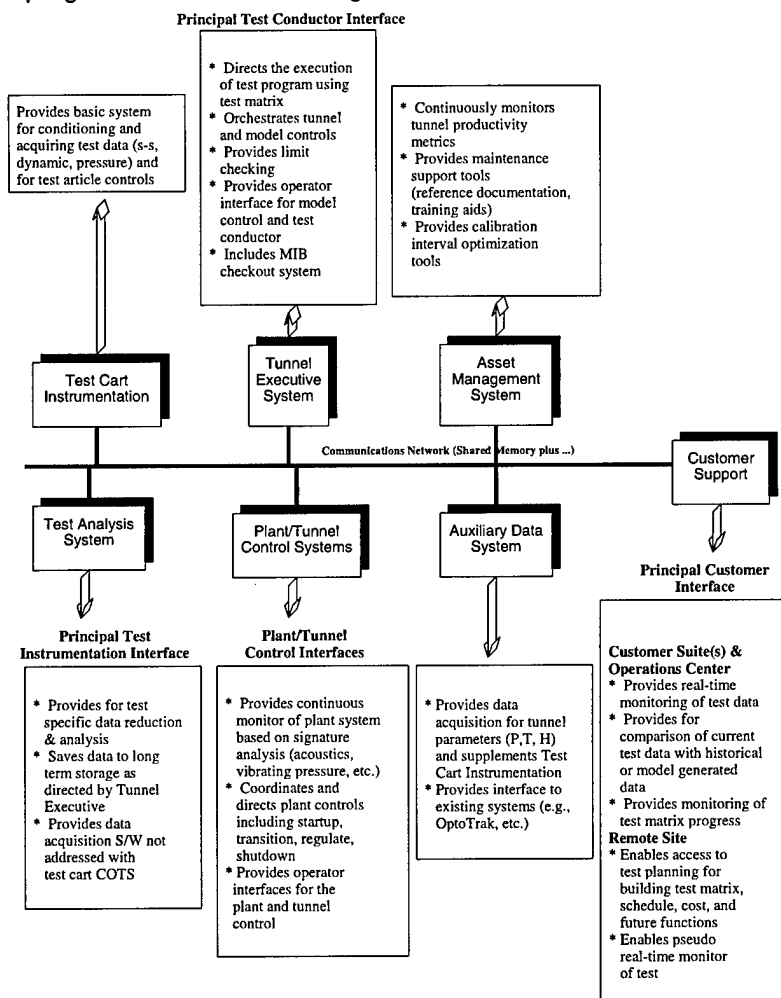

Fig. 3. Vision of Acquisition and Processing Systems (DAPS).

Test Data Analysis. The new DAP system will consist of a distributed hardware/software system design. This distributed design will allow the system to be easily configured to support the varying needs of the many types of tests performed in Tunnels 16T/S. A concept for the system is shown in Fig. 4.

layer, backbone switch capable of supporting 10 Mbit/sec Ethernet, 100 Mbit/sec Ethernet, FDDI, and ATM for connecting to the AEDC base networks and remote customers. The internal PWT LAN will be based on a switched, 100 Mbit/sec, ethernet.

### Network

The DAP system is a distributed computing system connected by both a real-time network (reflective memory) and a switched Ethernet, Local Area Network (LAN) within PWT.

The reflective memory network is the key component of the distributed system. The network provides a data common area for all attached computers; i.e., when one processor places data in reflective memory, it becomes available to all nodes with no processor overhead.

The DAP also uses a more traditional Local Area Network (LAN) to transmit system configuration and status data. The LAN will allow transmission of near real-time data to sites remote to PWT using TCP/IP software. The LAN will use a multi-

### Test Cart Instrumentation

One of the primary goals of the PWT Sustainment Project reduction of test installation time. The key element in reducing installation time is the placement of the data systems and test article controls on the test carts. Three data systems consisting of a Static Data Acquisition System (SDAS), a Pressure Scanning System (PSS), and a Dynamic Data System (DDAS) will be placed on the cart. The on-cart systems will be housed in pressure/temperature controlled enclosures located on the HAAS and CTS carts. In addition to reducing installation times, distances between measurement sensors and data acquisition equipment will be greatly reduced by the on-cart systems. The shorter cables will provide a significant increase in attainable data acquisition bandwidths and signal-to-noise ratios.

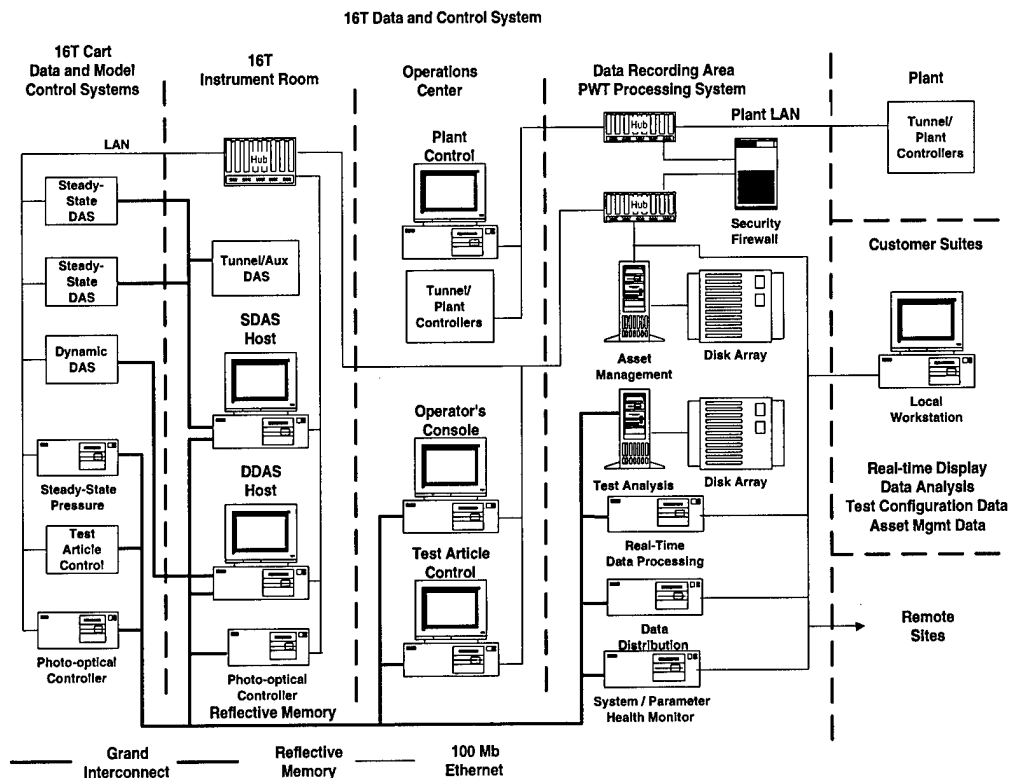

Fig. 4. Data Acquisition and Processing System (DAPS).

## Static Data Acquisition System (SDAS)

Steady-state measurements of force, strain-gage pressure, temperature, and miscellaneous analog signals are required in the PWT. The SDAS is based on VXI architecture incorporating multi-channel A/D cards with on-board and external signal conditioning. Force balances have high-quality signal conditioning external to the VXI chassis with constant current and voltage excitation capabilities. Miscellaneous strain-gage instrumentation, thermocouples, RTDs, and miscellaneous analog inputs are conditioned by VXI-based signal conditioning. The system controller is a Windows NT® PC. A block diagram of the SDAS is shown in Fig. 5.

Anticipated measurement uncertainties and scan rates for the above measurements are listed below.

- Force 0.1% FS
- Temperature  $\pm 2^\circ\text{F}$
- Pressure 0.1% FS
- Channel Scan Rate 100 Hz
- Bandwidth 2 to 10 Hz
- Data Update Rate 50 msec

The SDAS software performs the following functions:

- A/D and signal conditioning calibrations
- Data acquisition
- Engineering unit data calculation and storage in reflective memory
- Channel integrity monitoring

## Dynamic Data Acquisition System (DDAS)

Dynamic measurements of force, strain-gage pressure, and miscellaneous analog signals are required in the PWT. Dynamic measurements are required for tests such as inlet-engine testing, acoustic testing, flutter test, etc. The DDAS is also based on a VXI system. The system uses a sigma-delta analog-to-digital converter per channel. The DDAS acquires data in a slightly different manner than the SDAS. The DDAS acquires data upon command for a specified time interval. All digitized samples for each channel are placed in reflective memory, using a multi-buffered technique, and are

recorded to disk by the Test Analysis System. Channel capacity for each PWT cart is shown below.

### HAAS Cart

- Force Balance - 30 Channels
- Strain Gage - 96 Channels

### CTS CART

- Force Balance - 30 Channels
- Strain Gage - 48 Channels

Anticipated measurement uncertainties and scan rates for the above measurements are listed below.

- Force -  $\pm 1.0\%$  FS
- Pressure - 0 - 15 psi,  $\pm 1.0\%$  FS
- Bandwidth - 100 Hz to 10 kHz
- Max Scan Length- 60 sec
- Channel Time Correlation - 100 Hz to 2 kHz,  $\pm 1$  deg  
- 2 kHz to 20 kHz,  $\pm 2.5$  deg

The DDAS software performs the following functions:

- A/D and signal conditioning calibrations
- Data acquisition
- Digital filtering and storage of raw data in reflective memory
- Channel integrity monitoring

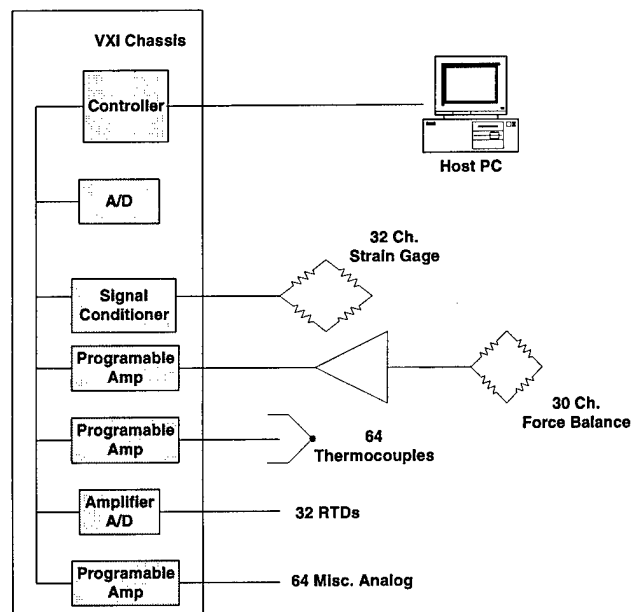

Fig. 5. Static data system.

## Pressure Scanning System (PSS)

PWT tests requiring the measurement of large numbers of pressures utilize electronically multiplexed pressure scanners. The system selected for the PSS is a PSI<sup>®</sup> 8400 processor. Each scanner is capable of measuring 64 pressures with semiconductor, temperature-compensated pressure transducers. These scanners and the digitizer are miniaturized and are normally placed inside the model in order to minimize pressure lags. Digitizers send digital data back to a host computer over fiber-optic cables. A block diagram of the system is shown in Fig. 6. The PSS provides the following measurement capabilities:

- Pressure Range - 1 psid to 500 psid
- Measurement Uncertainty- 0.05% FS
- Data Update Rates - 50 msec

## Test Article Control System (TACS)

Position and velocity control of the various 16T model support positioning systems must be provided by an on-cart data system. The TACS is a PC-based, multiprocessor VME system using digital position/velocity control. A PLC-based safety monitoring subsystem will monitor all limits and conditions that could be hazardous to both personnel and equipment. A block diagram of the system is shown in Fig. 7.

The following support systems must be controlled:

- 16T Pitch Boom System (2 DOF)
- 16 Haas Pitch system
- 16T Haas Roll system 1
- 16 Haas Roll System 2
- 16T Haas Aux. Roll System 1
- 16T Haas Aux. Roll System 2
- 16T Std Roll System
- 16S Std Roll System
- Spare Roll
- 16T Captive Trajectory System
- 16T Misc. DC Motor Control
- 16T Misc. Hydraulic Mechanisms

## HAAS Cart

- 4 Main Support Control Channels
- HAAS Pitch, Roll, Aux. Roll, & Pitch Table
- 8 Miscellaneous DC Motor or Hydraulic Control Channels

## CTS Cart

- 10 Main Support Control Channels
- CTS, Pitch Table, Pitch Boom, Std Roll, HP Pitch
- 8 Miscellaneous DC Motor or Hydraulic Control Channels

Position measurement requirements for the main support systems follow.

Mechanism	Readout Accuracy	Positioning Accuracy
16T Pitch Systems	0.005 deg	0.01 deg
16T Roll Systems	0.03 deg	0.1 deg
Pitch Boom Fwd/Aft	0.005 in.	0.01 in.
16T CTS Axial	0.07 in.	0.144 in.
16T CTS Horizontal	0.06 in.	0.12 in.
16T CTS Vertical	0.06 in.	0.12 in.
16T CTS Pitch	0.05 deg	0.09 deg
16T CTS Yaw	0.05 deg	0.09 deg
16T CTS Roll	0.15 deg	0.37 deg

Functional requirements for the above measurements include:

- A/D and signal conditioning calibrations
- Automatic and operator control of test article positions and velocities
- Engineering unit data calculation and storage in reflective memory
- Channel integrity monitoring
- Test article equipment and personnel protection

## Tunnel and Auxiliary Data System

Some data parameters must be measured which do not originate on the test cart. These parameters are mostly tunnel parameters such as tunnel total pressure, temperature, dewpoint, etc. These parameters will be acquired by a VXI-based data acquisition system, similar to the SDAS, which is not located on the cart. This system will

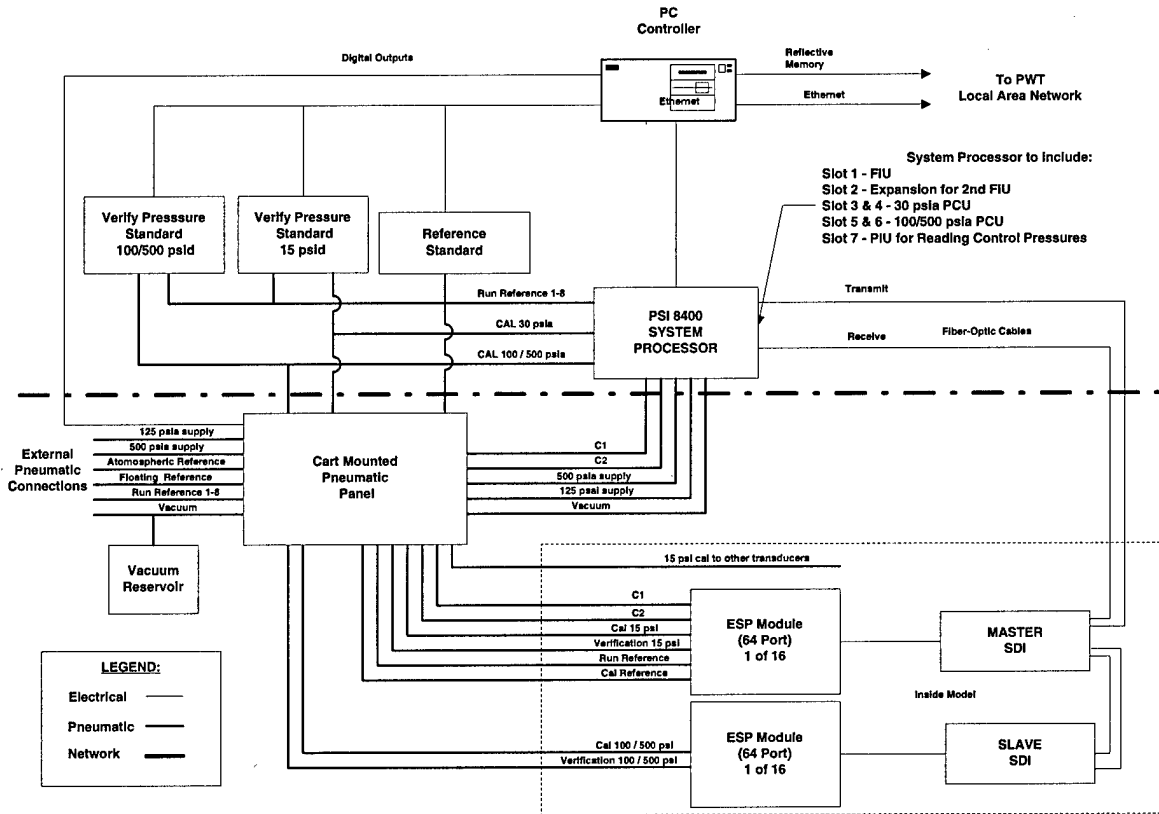

Fig. 6. PSS block diagram.

a

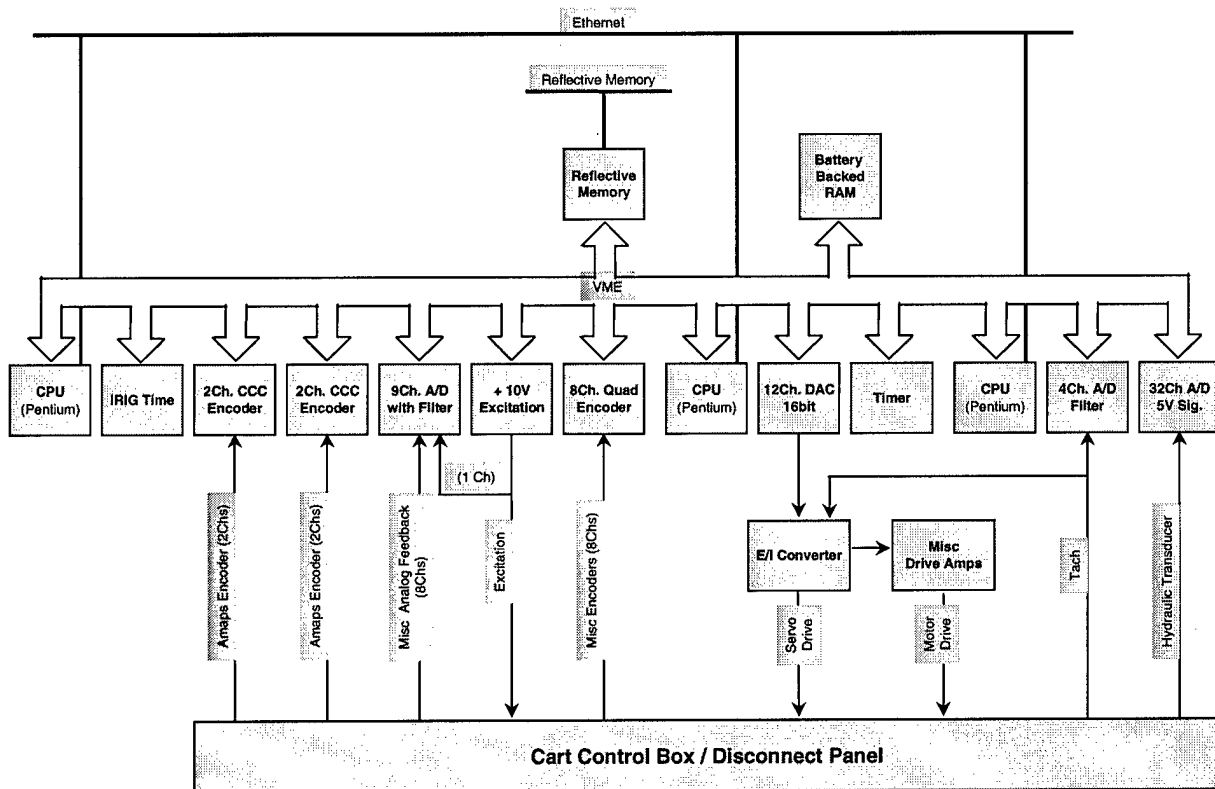

Fig. 7. Test article control block diagram.



so provide additional channel capacity for large tests where the on-cart channel capacities are exceeded. Auxiliary channels will be provided for miscellaneous strain gages, thermocouples, and direct voltage inputs.

Another auxiliary system which is not on the cart is the photo-optical control system. This system provides control capability for cameras, lights, VCRs, etc. which are used to acquire video data within the PWT.

### **Tunnel Executive**

The Tunnel Executive provides overall test direction and execution for the PWT DAPS. Operator and user workstations are based on Windows® NT-based PCs. The Executive supports move-pause, continuous trajectory, and continuous sweep modes of testing. The test execution is directed by a user-configurable test matrix stored on the Asset Management System discussed in the following section. In addition to providing sequencing capabilities, the Executive provides real-time data displays and system and parameter health monitoring capabilities. Real-time displays are user-configurable using a library of tabular and graphical display windows. The user may select any data parameter within the DAP system for display. Tabular displays are updated twice per second, and graphical displays are updated at least once per second. Health monitoring is also provided by the Tunnel Executive. Monitoring capabilities include:

- Real-time monitoring of distributed DAC systems
- Monitor engineering unit parameters for limits
- Balance load monitoring and protection

### **Asset Management System**

A Windows® NT database server is used to store data pertaining to the operation and set up of the DAP system. Items stored on this server include system configuration data, test sequencing matrices, calibration data, operating and maintenance instructions, technical manuals, productivity data, etc. Both internal and external customers will

access tools to develop test requirements and matrices in electronic form. Test configurations will be validated as entered by users.

In addition to all the information above, which is entered prior to testing, the system collects test unit and plant operational data related to productivity. Tracked items will include installation times, data points per hour, cost per data point, tunnel off-condition time, etc. These data can then be used to generate productivity reports and trends. An operations event log is also stored on the Asset Management System during operations. These messages are generated automatically by the various distributed computing systems, as well as manually by the tunnel operator. This event message log will provide a historical record of events during tunnel operations.

### **Test Analysis System (TAS)**

The TAS provides test-peculiar data reduction, short-term data archival, test article positioning algorithms, and analysis and display capabilities. The system is based on a Unix server with 100 Gb of disk storage. Steady-state data are recorded at rates up to 20 samples/sec. Dynamic data may be recorded at throughput rates up to 1 million samples/sec. Once recorded, any required test-unique calculations are performed, and the results are written to disk. These results may be reviewed by local and remote users using the many functions provided by the analysis software. Once testing and analysis are complete, data are transferred to the base central storage facility for permanent archival.

In addition to the above functions, the TAS performs the test-peculiar data reduction in real time. The results are placed on the reflective memory network so that test-peculiar data may be viewed using the real-time display capabilities of the Tunnel Executive.

### **Plant/Tunnel Control Systems**

The plant/tunnel controls portion of the Sustainment Program will automate and consolidate operation of the plant and tunnel systems such that

operation can be accomplished from a single work station. This is a change from the current operation from several different control rooms (i.e., 16T Control Room, PES Control Room, Drier Control Console, etc.) to a single Test Operations Center. In the Operations Center, an operator has access to completely integrated data acquisition, tunnel, and plant controls and monitoring. This is accomplished using an extensive CCTV monitoring and intercom system. Key features of the system include:

- Support remote monitoring and operations
- Provide fully integrated 16T and plant controls
- Redundant operator interface operation
- Redundant communications to field I/O and other local operator interfaces
- Support for redundant field controllers (where required)
- Field located I/O
- Field controller based on industrial standard bus

Major subsystems controlled and monitored by this integrated system include the existing PWT Drier, the Plenum Evacuation System, the Flexible Nozzle, and the K1 cooler.

### **Productivity Features**

Productivity enhancement is a primary objective of the DAPS portion of the PWT Sustainment Program. Achievement of improvements in facility productivity as measured in polars per hour and reduction in installation cycle time are specified requirements for the effort. Data and control system features which will provide this improvement are detailed in this section.

### **Reflective Memory Network**

As stated earlier, the reflective memory network is the key component of the distributed system. The network provides a data common area for all attached computers; i.e., when one processor places data in reflective memory, it becomes available to all nodes with no processor overhead.

The data transmission latency is only approximately 75  $\mu$ sec per node. Not only does the reflective memory provide high bandwidth, low-latency data transfer, it greatly simplifies the software

required for the DAPS. No software development is required to perform the data transfer. It also allows for easy consolidation and or distribution of software modules during system implementation. For example, if the processor for a data system becomes overloaded and cannot handle the required number of channels, a second processor can be added and the channel capacity divided between the two new processors. Minimal software development is required to add the second processor since both systems are doing exactly same functions.

The reflective memory network speeds the distribution of data among the system nodes as well as increasing system flexibility for addition of data sources and nodes. This increases productivity by reducing data cycle and system reconfiguration times.

### **On-Cart Data Acquisition Systems**

The most drastic change for the new DAPS system from the current system is the placement of major data system components on the two Tunnel 16T test carts. Data acquisition equipment will be located in climate-controlled enclosures to maintain operating temperature and pressure of the equipment. By locating these systems on the cart, test buildup, instrumentation hookup, and checkout will be significantly enhanced by eliminating redundant steps of checkout and calibration which often result from using different data systems for pre-test checkout and in-tunnel operation.

When full advantage of the pre-test checkout of the model/instrumentation systems is accomplished in the Model Installations Building, the in-tunnel installation can be performed in a much shorter time period. This in-tunnel installation process, which currently averages almost 50 hours, will be accomplished in less than 4 hours with the new system.

Sizing of the data system channel count was performed such that all of the tests run in Tunnel 16T in the last 10 years could be easily accommodated with the on-cart systems. In addition, an auxiliary data system is provided which can handle any excess instrumentation requirements not covered by the on-cart systems.

The on-cart data systems offer many advantages for test productivity in Tunnel 16T. The most important advantage is reduction of the tunnel installation to less than 4 hours, as this will significantly increase the throughput of testing in this heavily scheduled facility. Availability of the test cart prior to the test is critical to meeting this requirement. Scheduling of tests to alternate use of the test carts is a strategy which is often overridden by the realities of test priorities and test type mix. Future addition of a third test cart is being considered to take full advantage of the on-cart data systems by allowing adequate preparation time in the Model Installation Building for all tests.

### Data Cycle Time

Optimization of on-line data cycle time is a key element in the minimization of test cost. Because of the required technical and craft support staff, and because significant amounts of energy resources are being expended to maintain test conditions, this is the most expensive phase of the test project. Minimal improvements in the data acquisition cycle time translate into significant cost savings to our test customers. The target for the sustainment project is a 25-percent reduction for acquisition of a typical polar or a reduction from 2.15 minutes to 1.6 minutes.

To make the comparison, it is first necessary to define the baseline polar and baseline test configuration. The baseline test configuration consists of a test article instrumented with a balance for force and moment data, digital inputs for test condition and position data, and up to six ESP modules for pressure data. Data are to be acquired through a move/pause sweep in 3-deg Alpha increments. This baseline configuration is typical of force and moment test projects executed in Tunnel 16T.

The steps currently required, along with the time required to perform these steps, are shown in Fig. 8. The current data acquisition system and network configuration consists of an Operator Inter-

face Computer; a steady-state data acquisition system; a digital data acquisition and control system; a pressure system which includes an individual transducer acquisition subsystem and an ESP subsystem; and a facility computer. The facility computer orchestrates the current data acquisition sequence by stepping through a predefined table of model positions and acquiring data at each position. Moving the model from one position to the next requires that the facility computer make sting and balance deflection, flow angle, and other corrections to the model set points to meet tolerance checks of the model position. During model movement, the facility computer acquires position and force and moment data and outputs corrected position setpoints at a rate of 10 times per second. Therefore, as the model moves and the corrections change, the final setpoints are adjusted so that the model flies to the correct position. It should be noted that when the process thinks it has the model positioned within tolerance, it makes one more pass to make sure before recording the data point. After the model is positioned the sequence is delayed, typically one-half second, for data settling before the data point is acquired. Notice here that the data are acquired in a serial manner, one data acquisition system/subsystem at a time. Also note that the data are acquired from the slowest systems first, thereby allowing more settling time for the force and moment data acquired from the steady-state data system. After the data are packaged into a data point, there is a small amount of time spent in overhead processing of the point, informing the operator interface of the status, and archiving the point to storage for further data reduction and analysis by other processes and systems. As can be seen, this cycle adds up to 5.17 seconds per point for a total of 2.15 minutes for the polar.

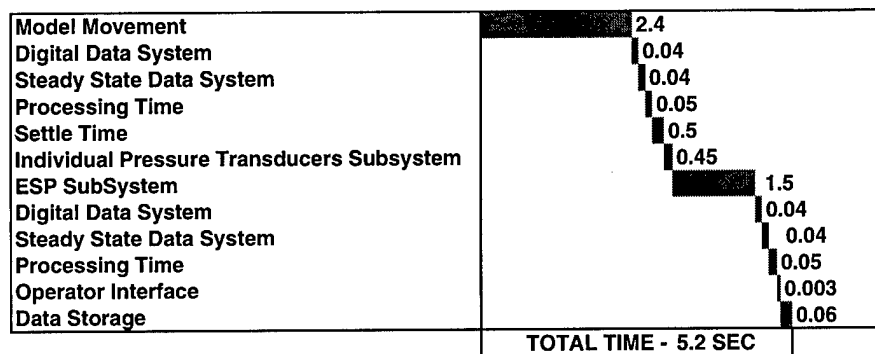

Fig.8. Current data cycle process and times.

Typically when a process is examined for improvement opportunities, the first place to look is in the activities requiring the most resources. Through a Pareto analysis of the time segments, it was determined that model movement and pressure data acquisition accounted for 84 percent of the cycle time. Very little improvement could be identified to reduce the model movement time because of the physical limitations of the model support system and the fact that the setpoint correction calculations have already been optimized over the last few years. This left the pressure data acquisition as the primary target for reduction. The current pressure system is made up of two subsystems, the individual transducer subsystem and the ESP subsystem. Both subsystems provided data to the facility computer only on request. It was determined that the individual transducer subsystem was really just more analog steady-state inputs and could be moved to the new SDAS, thus eliminating the 0.45 sec time to acquire those data. The 1.5-sec ESP subsystem time resulted from the process performing data averaging only on data request. In other words, when the ESP system received a data request, it performed the data acquisition and averaging before sending the data to the requestor. The new system, the PSS, performs these averaging calculations continuously, making the data available immediately. The second place to look for improvement opportunities is to search for activities currently done serially which could be done in parallel. It becomes immediately obvious that the serial acquisition of data after the model is on position is a significant improvement opportunity. The new systems, therefore, have been designed to continuously place their digitally filtered and averaged data on the reflective memory network for all that need it. Now, instead of polling each data system for its data, the reflective memory containing current data is recorded and packaged as a data point, eliminating the serial activities. One caveat to be noted here is that the time spent acquiring pressure data under the old process was essentially data settling time for the force and moment data. Therefore, it is expected that the settling time segment will increase from 0.5 seconds to 1 second, eliminating

some of the improvement. The final improvement area deals with the recording of the data point. A new system was designed to record a data point by scanning of the reflective memory network, thereby eliminating the need for this activity in the sequencing process. The sequencing process must only indicate to the data recording system, which is optimized to perform this function, when a point is required.

Charting the new activities, Fig. 9, shows the results of the improved process. As can be seen, the new cycle time has been reduced to 3.40 seconds, resulting in a 25-point polar time of 1.42 minutes. This results in a 33-percent reduction for acquisition of a typical polar, exceeding the original target improvement of 25 percent.

### Integration & Automation of Plant, Tunnel, and Test Article Controls

Automation and consolidation of controls associated with the testing process will enable 16T testing to be directed from a single work station in the 16T Operations Center. By eliminating peripheral control rooms, coordination of operational steps in the tunnel will be significantly reduced or eliminated. Only certain once-per-shift functional steps such as ordering power, cooling water, and other required utilities will remain. Operational productivity will be enhanced by elimination of coordination steps and the time lag associated with each.

Tunnel controls automation provides a streamlining of process steps involved with setting and maintaining test conditions in the wind tunnel. The automated process incorporates feed forward controls and automatic selection of plant configurations to enable streamlined test execution through

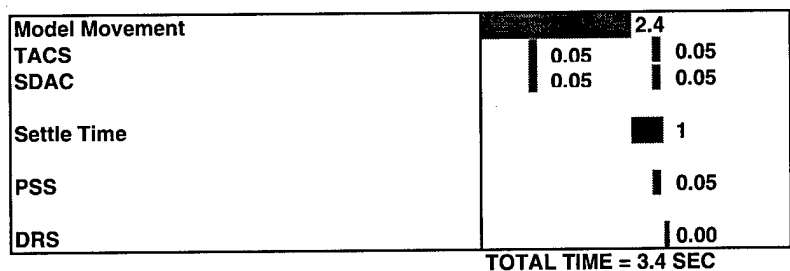

Fig.9. Data cycle process and times with new data system.

pre-selected test condition matrices. The tunnel control system provides for seamless operational sequencing through the various regimes associated with controlling Tunnel 16T test conditions. Incorporation of model controls into the operational sequence allows for predictive changes of tunnel control parameters to allow for scheduled changes in model position and the subsequent effect on tunnel conditions. Control system replacements are included in the program for the tunnel cooler and nozzle systems. The new control systems for these systems will speed up the control process in establishing, controlling, and changing test conditions.

A significant overall increase in productive air-on time in the wind tunnel is projected as a result of controls automation and integration. Typical reductions in tunnel startup and test condition change times required of the new systems are shown below.

Item	Current	Future
Compressor start to test condition (M = 0.8, Pt = 1200 psfa), min	8.5	6
Change condition 0.1 @ M < 0.7, min	5	2.5
Change condition 0.1 @ 0.7 < M < 1.0, min	2	1
Change condition 0.1 @ M > 1.0	5	2.5
Stagnation temperature stabilization, initial, min	5	1
Stagnation temperature restabilization, min	3	0
Tunnel shutdown to atmosphere, min	5	2.5

#### Diagnostic Features

During the course of tunnel test operations, problems will occur regardless of the level of planning and preparation for the effort. Efficient reaction and resolution of the problems are primarily a function of the knowledge of test support staff and the diagnostic capabilities of the tunnel data and control systems. Past systems have lacked effective diagnostic features to accurately detect problems and isolate system faults which contribute to the problem. The new data and control system provides a strong emphasis on correcting this deficiency. Each subsystem has built-in diagnostic capabilities which provide warning and or alarming

of fault conditions. Typically, faults are messaged to the Master Operator Control Station via the Health Monitoring and Message Logging Systems. The operations specialist at the Master Operator Control Station has responsibility for acknowledgment and action for system faults.

Productivity enhancements are achieved as a result of the data system diagnostic features by early notification of problems and quick diagnosis of root causes. It is difficult to quantify the improvement potential for this system improvement; however, mean-time-to-repair for downtime events will be reduced and the potential for obtaining erroneous data will be significantly reduced.

#### Summary/Conclusions

Replacement of the Data Acquisition Processing and Control System for Tunnel 16T will provide a very significant improvement in the productivity capability of this important national asset. The high-level productivity goals for the effort are very ambitious: an order of magnitude reduction in tunnel installation time and an 80-percent improvement in polars per occupancy hour. Achieving these goals is obviously dependent upon successful management and completion of the DAPS project; however, reengineering of the test processes must also be accomplished in order to take full advantage of the capability. In addition, partnering with the test customer to mutually define model and test requirements which will deliver high-quality information in the high productivity test environment is essential. The bottom line is that new equipment alone cannot provide quantum gains in test capability, but rather must be synergistic with the people and processes.