



DEFENCE RESEARCH ESTABLISHMENT
CENTRE DE RECHERCHES POUR LA DÉFENSE
VALCARTIER, QUÉBEC



DREV - TM - 1999 - 110

Unlimited Distribution / Distribution illimitée

The Effect of Styrofoam Interlayers in Fragment Witness Packs

by

G. McIntosh

September/septembre 1999

RESEARCH AND DEVELOPMENT BRANCH
DEPARTMENT OF NATIONAL DEFENCE
CANADA
BUREAU - RECHERCHE ET DÉVELOPPEMENT
MINISTÈRE DE LA DÉFENSE NATIONALE

DTIC QUALITY INSPECTED 4

19991123 084

Canada

SANS CLASSIFICATION

AQF00-02- 0527

UNCLASSIFIED

DEFENCE RESEARCH ESTABLISHMENT
CENTRE DE RECHERCHES POUR LA DÉFENSE
VALCARTIER, QUEBEC

DREV - TM - 1999 - 110

Unlimited Distribution / Distribution illimitée

The Effect of Styrofoam Interlayers in Fragment Witness Packs

by

G. McIntosh

September/septembre 1999

Approved by/approuvé par

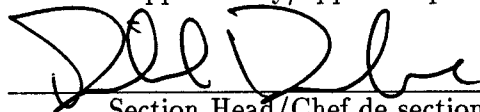
Section Head/Chef de section

99/09/15
Date

SANS CLASSIFICATION

0527

ABSTRACT

Witness packs are used to obtain the mass-velocity distribution of fragments generated, for example, at complete perforation of a target. A witness pack consists of several metallic layers of various materials and thicknesses spaced evenly. The STANAG 4190 description requires a low density Styrofoam spacer between the layers. Previous computer simulations of witness packs have been reported but were simplified by using air gaps. This document describes new computer simulations with a low density Styrofoam layer between each layer. It was difficult to describe the Styrofoam mechanical properties exactly but an approximate representation was used. The study presented in this memorandum shows that the Styrofoam does have a significant effect on the results of the mass-velocity distribution and therefore, one should be very careful when comparing simulations done with and without the Styrofoam to experimental results.

RÉSUMÉ

On utilise des panneaux témoins pour obtenir la distribution masse-vitesse de fragments générés, par exemple, derrière le blindage d'un véhicule. Les panneaux sont constitués de plusieurs feuilles de métal de divers matériaux d'épaisseurs variées et séparés par des espaces constants. La norme STANAG 4190 exige l'utilisation de styromousse pour assurer un espace constant. On a déjà rapporté des simulations par ordinateur dans le cas simplifié d'un espace rempli d'air. Ce document décrit de nouvelles simulations avec l'espace rempli de styromousse de faible densité. On a estimé les propriétés mécaniques de la styromousse ont été estimées. Cette étude démontre que l'effet de la styromousse est significatif. On devrait donc être prudent en comparant les résultats générés par simulation, avec ou sans styromousse, aux résultats expérimentaux.

TABLE OF CONTENTS

ABSTRACT/RÉSUMÉ	i
EXECUTIVE SUMMARY	v
LIST OF SYMBOLS	vii
1.0 INTRODUCTION	1
2.0 MODEL DESCRIPTION	1
3.0 RESULTS AND DISCUSSIONS	3
4.0 CONCLUSIONS AND RECOMMENDATIONS	6
5.0 REFERENCES	8

FIGURES 1 and 2

TABLES I to IV

EXECUTIVE SUMMARY

When a projectile strikes and penetrates an armoured vehicle, a cloud of behind armour debris, consisting of many fragments of various sizes and velocities, can be generated inside the vehicle. To evaluate the lethality of these fragments, some idea of the distribution of their masses and velocities is required. One way to acquire this information is by using witness packs which are made up of several metallic layers of various materials and thicknesses, evenly spaced and supported by low density styrofoam spacers between the layers, as required by the STANAG 4190 standard. Computer simulations of the perforation of the witness pack by fragments are used to better interpret the mass-velocity distributions.

At DREV, computer simulations were performed some years ago of the perforation of a witness pack by a fragment simulating projectile. However, in those simulations, a simplification of the problem was made by omitting the styrofoam layers. Recently, questions arose as to whether or not the styrofoam layers should be neglected. Further simulations using the hydrodynamic finite element computer program LS-DYNA2D were undertaken, this time including the styrofoam. A simplified constitutive model for the styrofoam was used. The present research has determined that in computer simulations, the addition of styrofoam layers has a significant effect on the mass-velocity distribution results. For each layer and fragment mass, a higher impact velocity was required for perforation when the styrofoam was present. Thus, any future simulations of witness packs should not ignore the styrofoam, if it is present.

This work was performed at Defence Research Establishment Valcartier between October 1998 and March 1999 under Work Unit 2fh13, "Numerical Modelling of Ballistic Events", and is reported in DREV document TM-1999-110 (1999), "The Effect of Styrofoam Interlayers in Fragment Witness Packs", by Grant McIntosh.

LIST OF SYMBOLS

bql	linear bulk viscosity coefficient
bqq	quadratic bulk viscosity coefficient
bqt	bulk viscosity type
c0 ... c5	parameters for polynomial equation of state
e	Young's modulus
eh	plastic hardening modulus
etan	hardening modulus
f_s	failure strain
G	shear modulus
hgq	hourglass viscosity coefficient
hgqt	hourglass viscosity type
pc	pressure cutoff
pr	Poisson's ratio
sp	sound speed
s1	slope in shock-particle velocity Hugoniot plane
β	hardening parameter (in elastic-plastic model)
γ	Gruneisen gamma constant
ρ	density
σ_y	yield strength
LSTC	Livermore Software Technology Corporation

The above list is not exhaustive but does include most of the symbols used in this document.

1.0 INTRODUCTION

Witness packs are used to gain some idea of the mass-velocity distribution of fragments generated, for example, at complete perforation of a target. A witness pack consists of several metallic layers of various materials and thicknesses spaced evenly. The STANAG 4190 description requires a low density styrofoam spacer between the layers, the function of which being to maintain the rigidity of the witness pack as well as to ensure an even and constant spacing between the metallic sheets. Computer simulations have been previously reported for a simplified witness pack in which air gaps were used (Ref. 1). The current document describes new computer simulations with a low density styrofoam layer between each metallic sheet.

This work was performed at DREV between October 1998 and March 1999 under Work Unit 2fh13, Numerical Modelling of Ballistic Events.

2.0 MODEL DESCRIPTION

The finite element hydrodynamic computer program LSDYNA-2D was used to simulate the penetration and perforation of the various layers of a witness pack by high velocity fragments. The simulations were performed with azimuthal symmetry (in 2-D) and thus, equivalent fragment simulating projectiles (FSP) (made of 4340 steel) were used. The projectiles were launched at various velocities between 75 and 1000 m/s onto a 4-layer witness

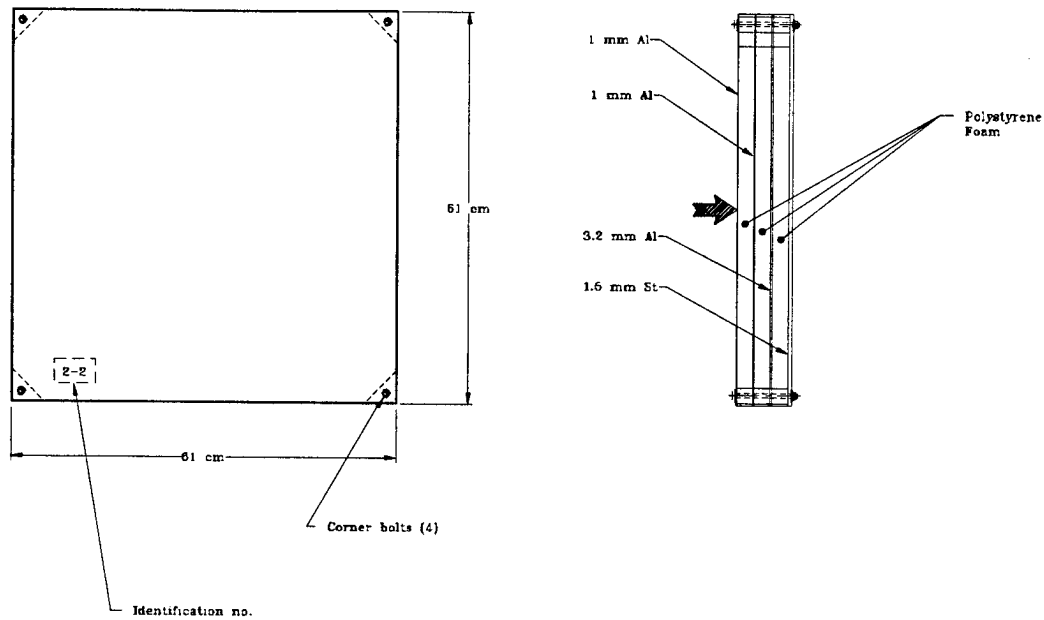

FIGURE 1 - Witness pack configuration

pack consisting of sheets (in order of appearance) of 1-mm 2024 aluminum, 1-mm 2024 aluminum, 3-mm 2024 aluminum and 1.5-mm 1020 steel with a 25.4-mm layer of styrofoam between the metal sheets. Figure 1 shows the true witness pack configuration. Approximate (bracketed) ballistic limits were found by noting the degree of penetration for each mass and for each velocity. A bracketed ballistic limit is the average of the highest velocity which does not perforate a given layer and the lowest velocity which does. The material properties used are described in Tables I-IV. For the styrofoam, material properties were found in the manufacturer's literature (Ref. 2) and in the shock wave literature (Ref. 3). The constitutive model used is not the best for this material but it should give some idea of the magnitude of the importance of the styrofoam in a witness pack.

The mesh was not optimized (a coarser mesh could possibly have been used) but

TABLE IParameters for styrofoam

Parameter	Value
ρ	0.03 g cm ⁻³
G	0.000576 MBar
σ_y	2.5E-06 MBar
pc	-5.E-06 MBar
f_s	0.25
hgqt	4
hgq	0.4
bqt	1
bqq	1.5
bql	0.06
sp	0.025 cm μ s ⁻¹
s1	1.22
γ	2.0

the mesh used gave identical results to a mesh which was twice as fine. To better resolve the projectile target interactions, the mesh was more finely zoned near the impact point. The outer edges of the layers were fixed, to simulate a clamped-down condition.

3.0 RESULTS AND DISCUSSIONS

Figure 2 shows the results from the current series of simulations as well the original series of Ref. 1. As is readily seen, the addition of styrofoam does have a significant effect on the interpretation of the witness pack results. For every mass and every metal layer, a higher ballistic limit is observed when the styrofoam is present. For example, for a 10-gram FSP, the ballistic limit for the second layer with an air gap is around 189 m/s whereas, with

TABLE IIParameters for 1020 steel

Parameter	Value
ρ	7.83 g cm ⁻³
G	0.802 MBar
σ_y	0.00424 MBar
eh	0.00636 MBar
pc	-0.03840 MBar
f_s	1.5
hgqt	4
hgq	0.40
bqt	1
bqq	1.5
bql	0.06
c0	0.
c1	1.28
c2	1.05
c3	0.
c4	2.0
c5	2.0
c6	0.

TABLE IIIParameters for 4340 steel

Parameter	Value
$\rho(\text{effective})$	5.80 g cm ⁻³
e	2.068 MBar
pr	0.30
σ_y	0.01059 MBar
etan	0.01903 MBar
β	1.
hgqt	4
hgq	0.40
bqt	1
bqq	1.5
bql	0.06

TABLE IVParameters for aluminum 2024T3

Parameter	Value
ρ	2.77 g cm ⁻³
G	0.275 MBar
σ_y	0.00352 MBar
eh	0.00665 MBar
pc	-0.01125 MBar
f_s	0.54
hgqt	4
hgq	0.40
bqt	1
bqq	1.5
bql	0.06
c0	0.
c1	0.75
c2	0.65
c3	0.
c4	2.13
c5	2.13
c6	0.

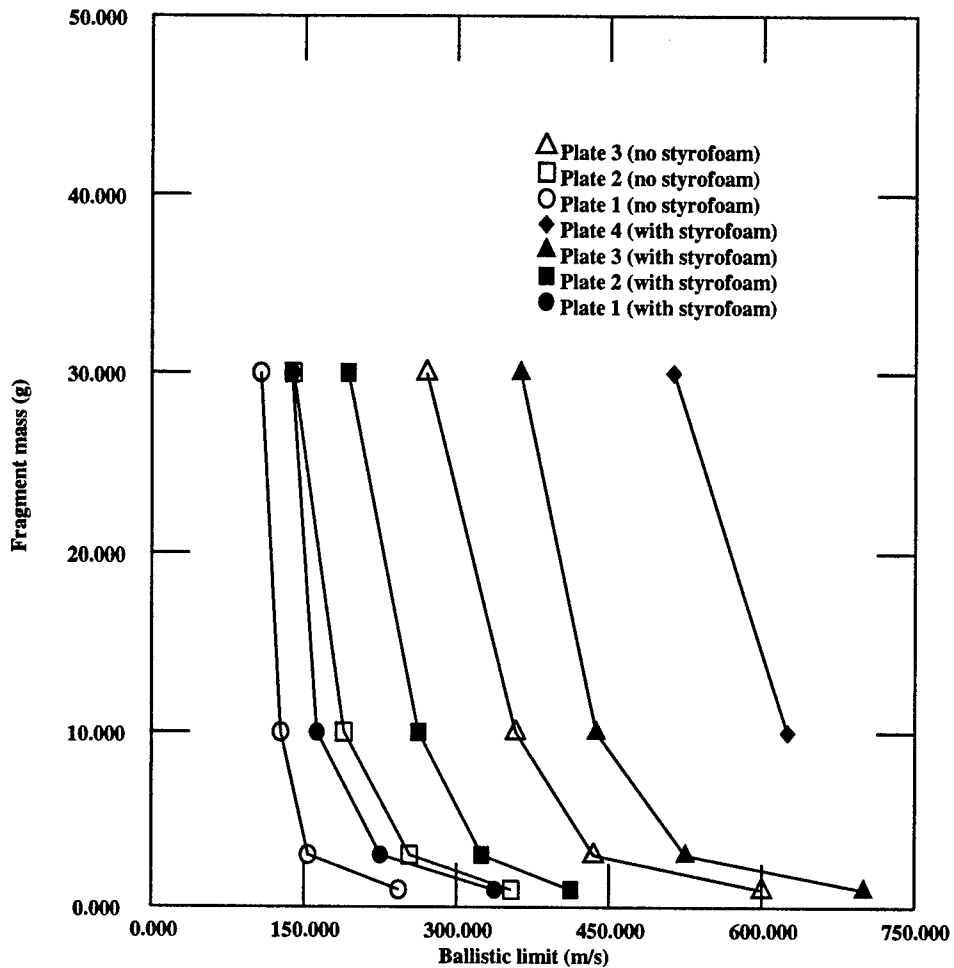

FIGURE 2 - Comparison of ballistic limits with and without styrofoam

the air replaced by styrofoam, the limit increases to around 262.5 m/s. This indicates that the styrofoam's effect cannot be neglected.

4.0 CONCLUSIONS AND RECOMMENDATIONS

The effect of styrofoam in a witness pack cannot be neglected. One should be careful when comparing the results with styrofoam to results without styrofoam. A witness

UNCLASSIFIED

7

pack made with styrofoam spacers should be calibrated experimentally before definitive conclusions about the mass-velocity distributions of behind armour debris are drawn.

5.0 REFERENCES

1. Nandlall,D., Szymczak,M., Anthony,R., "The Numerical Development of Calibration Curves for Behind-Armour Debris Analysis", 15th International Symposium on Ballistics, Jerusalem, Israel, 21-24 May 1995, pp. 487-494
2. <http://www.styrofoam.net.au/prodat2.htm> for Styrofoam SM
3. Marsh, Stanley P., "LASL Shock Hugoniot Data", University of California Press Berkeley, California, 1980

UNCLASSIFIED

INTERNAL DISTRIBUTION

DREV - TM - 1999 - 110

- 1 - Director General
- 1 - Deputy Director General
- 1 - Chief Scientist
- 6 - Document Library
- 1 - Head, Weapons Effects Section
- 1 - Dr. G. McIntosh (author)
- 1 - Dr. D. Nandlall
- 1 - Dr. K. Williams
- 1 - Mr. M. Szymczak
- 1 - Mr. G. Pageau
- 1 - Mr. Y. Baillargeon

UNCLASSIFIED

EXTERNAL DISTRIBUTION

DREV - TM - 1999 - 110

- 1 - DRDCIM
- 1 - DRDCIM (unbound copy)
- 1 - DRDB
- 1 - DSAL
- 1 - DSAL-2
- 1 - DSAL-4
Attn: Mr. David Saint
- 1 - DAES
- 1 - DAES-3
- 1 - DFTEM-1
- 1 - DRES
Attn: Dr. C. Weickert

- 1 - National Library of Canada
- 1 - CISTI
- 1 - DTIC

- 1 - Livermore Software Technology Corporation
Attention: Dr. J.O. Hallquist
2876 Waverley Way
Livermore, California, USA 94550

UNCLASSIFIED
SECURITY CLASSIFICATION OF FORM
(Highest classification of Title, Abstract, Keywords)

DOCUMENT CONTROL DATA

1. ORIGINATOR (name and address) Defence Research Establishment Valcartier 2459 Pie-XI Blvd North Val-Belair, Qc G3J 1X5 Canada		2. SECURITY CLASSIFICATION (Including special warning terms if applicable) Unclassified	
3. TITLE (Its classification should be indicated by the appropriate abbreviation (S, C, R or U)) The Effect of Styrofoam Interlayers in Fragment Witness Packs			
4. AUTHORS (Last name, first name, middle initial. If military, show rank, e.g. Doe, Maj. John E.) McIntosh, G.			
5. DATE OF PUBLICATION (month and year) 1999		6a. NO. OF PAGES 10	6b. NO. OF REFERENCES 3
7. DESCRIPTIVE NOTES (the category of the document, e.g. technical report, technical note or memorandum. Give the inclusive dates when a specific reporting period is covered.) technical memorandum			
8. SPONSORING ACTIVITY (name and address)			
9a. PROJECT OR GRANT NO. (Please specify whether project or grant) 2fh13, Numerical Modelling of Ballistic Events		9b. CONTRACT NO.	
10a. ORIGINATOR'S DOCUMENT NUMBER DREV -TM-1999-110		10b. OTHER DOCUMENT NOS N/A	
11. DOCUMENT AVAILABILITY (any limitations on further dissemination of the document, other than those imposed by security classification) <input checked="" type="checkbox"/> Unlimited distribution <input type="checkbox"/> Contractors in approved countries (specify) <input type="checkbox"/> Canadian contractors (with need-to-know) <input type="checkbox"/> Government (with need-to-know) <input type="checkbox"/> Defense departments <input type="checkbox"/> Other (please specify)			
12. DOCUMENT ANNOUNCEMENT (any limitation to the bibliographic announcement of this document. This will normally correspond to the Document Availability (11). However, where further distribution (beyond the audience specified in 11) is possible, a wider announcement audience may be selected.)			

UNCLASSIFIED
SECURITY CLASSIFICATION OF FORM
(Highest classification of Title, Abstract, Keywords)

UNCLASSIFIED
SECURITY CLASSIFICATION OF FORM
(Highest classification of Title, Abstract, Keywords)

13. ABSTRACT (a brief and factual summary of the document. It may also appear elsewhere in the body of the document itself. It is highly desirable that the abstract of classified documents be unclassified. Each paragraph of the abstract shall begin with an indication of the security classification of the information in the paragraph (unless the document itself is unclassified) represented as (S), (C), (R), or (U). It is not necessary to include here abstracts in both official languages unless the text is bilingual).

Witness packs are used to obtain the mass-velocity distribution of fragments generated, for example, at complete perforation of a target. A witness pack consists of several metallic layers of various materials and thicknesses spaced evenly. The STANAG 4190 description requires a low density Styrofoam spacer between the layers. Previous computer simulations of witness packs have been reported but were simplified by using air gaps. This document describes new computer simulations with a low density Styrofoam layer between each layer. It was difficult to describe the Styrofoam mechanical properties exactly but

an approximate representation was used. The study presented in this report shows that the Styrofoam does have a significant effect on the results of the mass-velocity distribution and therefore, one should be very careful when comparing simulations done with and without the Styrofoam present to experimental results.

14. KEYWORDS, DESCRIPTORS or IDENTIFIERS (technically meaningful terms or short phrases that characterize a document and could be helpful in cataloguing the document. They should be selected so that no security classification is required. Identifiers, such as equipment model designation, trade name, military project code name, geographic location may also be included. If possible keywords should be selected from a published thesaurus, e.g. Thesaurus of Engineering and Scientific Terms (TEST) and that thesaurus-identified. If it is not possible to select indexing terms which are Unclassified, the classification of each should be indicated as with the title.)

styrofoam
finite elements
DYNA2D
witness packs
behind-armour effects
behind-armour debris

UNCLASSIFIED
SECURITY CLASSIFICATION OF FORM
(Highest classification of Title, Abstract, Keywords)