

U.S. Coast Guard Research and Development Center  
1082 Shennecossett Road, Groton, CT 06340-6096

---

Report No. **CG-D-09-99, III**

**United States Coast Guard  
Integrated Risk Assessment Process**

**Volume III**

(Detailed Hazard Analysis of WMEC-270 Small Boat  
Operations, Detailed Hazard Analysis of WLIC-160  
Deck Operations, and Risk-based Safety Survey of  
a WHEC-378 Vessel)

19990831 107



FINAL REPORT  
SEPTEMBER 1998



This document is available to the U.S. public through the  
National Technical Information Service, Springfield, VA 22161

Prepared for:

U.S. Department of Transportation  
United States Coast Guard  
Human Resources (G-W)  
Washington, DC 20593-0001

**DISTRIBUTION STATEMENT A**  
Approved for Public Release  
Distribution Unlimited

DTIC QUALITY INSPECTED 4

# NOTICE

This document is disseminated under the sponsorship of the Department of Transportation in the interest of information exchange. The United States Government assumes no liability for its contents or use thereof.

The United States Government does not endorse products or manufacturers. Trade or manufacturers' names appear herein solely because they are considered essential to the object of this report.

This report does not constitute a standard, specification, or regulation.



Marc B. Mandler, Ph.D.  
Technical Director  
United States Coast Guard  
Research & Development Center  
1082 Shennecossett Road  
Groton, CT 06340-6096



1. Report No. CG-D-09-99, III		2. Government Accession No.		3. Recipient's Catalog No.	
4. Title and Subtitle United States Coast Guard Integrated Risk Assessment Process, Volume III (Detailed Hazard Analysis of WMEC-270 Small Boat Operations, Detailed Hazard Analysis of WLIC-160 Deck Operations, and Risk-based Safety Survey of a WHEC-378 Vessel)				5. Report Date September 1998	
				6. Performing Organization Code Project No. 9920	
7. Author(s) William H. Jones, Vernon Guthrie, David Walker, Thomas Zanin and Andrew Huff				8. Performing Organization Report No. R&DC 27/97, III / UDI 126	
9. Performing Organization Name and Address U.S. Coast Guard Research and Development Center 1082 Shennecossett Road Groton, CT 06340-6096				10. Work Unit No. (TRAIS)	
				11. Contract or Grant No. DTCG39-95-D-E00395	
12. Sponsoring Agency Name and Address U.S. Department of Transportation United States Coast Guard Human Resources (G-W) Washington, DC 20593-0001				13. Type of Report and Period Covered Final Report	
				14. Sponsoring Agency Code Commandant (G-WKS) U.S. Coast Guard Headquarters Washington, DC 20593-0001	
15. Supplementary Notes The Coast Guard technical contact is Bert Macesker (860-441-2726) of the U.S. Coast Guard Research and Development Center. The project officer at Coast Guard Headquarters is CDR Rickey George, (G-WKS-4).					
16. Abstract  Due to the new challenges (e.g., government downsizing, increased system complexity, ever-changing high-risk operations) faced by the Coast Guard, the Coast Guard Research and Development Center (RDC) was requested to explore the possibility of applying system safety concepts, including the use of risk analysis and enhancement of inspection procedures, to improve Coast Guard operations and facility safety. The Coast Guard RDC teamed with JBF Associates, Inc. (JBFA), a consulting firm specializing in hazard and risk analysis/management, to develop a risk-based loss prevention program. The initial focus was on developing one portion of the risk-based loss prevention program, a risk assessment process. This report discusses the development, validation, and end product (the Integrated Risk Assessment [IRA] process) of this effort. Effective implementation of the IRA process provides the Coast Guard with risk-based information for: 1) controlling and reducing loss exposure, (2) making risk-based decisions, and (3) using limited resources more efficiently. The IRA process proved to be an effective and efficient risk assessment tool for various types of vessels and their operations, as well as shore facilities and their operations.  This report contains three volumes. Volume I consists of the main text of the report and Attachment A: Integrated Risk Assessment (IRA) Manual. Volume II consists of Attachment B: Coarse Hazard Analysis of a WMEC-210 Vessel in Support of the Paragon Project and Attachment C: Coarse Hazard Analysis of the Integrated Support Command (ISC) at Seattle, WA. Volume III consists of Attachment D: Detailed Hazard Analysis of WMEC-270 Small Boat Operations, Attachment E: Detailed Hazard Analysis of WLIC-160 Deck Operations, and Attachment F: Risk-based Safety Survey of a WHEC-378 Vessel.					
17. Key Words Loss Exposure and Risk Analysis Methodology; LERAM; Integrated Risk Assessment Process; IRA; risk assessment; hazard identification; risk analysis; risk-based safety survey			18. Distribution Statement This document is available to the U.S. public through the National Technical Information Service, Springfield, VA 22161.		
19. Security Classif. (of this report) UNCLASSIFIED		20. SECURITY CLASSIF. (of this page) UNCLASSIFIED		21. No. of Pages	22. Price

[ This page intentionally left blank. ]

## **Attachment D**

### ***Detailed Hazard Analysis of WMEC-270 Small Boat Operations***

This attachment contains the results of a detailed risk analysis (formerly called detailed hazard analysis) of WMEC-270 small boat operations. The WISE analysis technique was used in this study, coupled with a human error (error-likely situation) review and a procedural review. Included are typical results produced by the analysis and the raw data collected during the analysis sessions. Because of the specific expertise required, most detailed analyses like this will be performed by outside experts in the techniques, rather than by Coast Guard personnel.

JBFA-101-01-05-94

**UNITED STATES COAST GUARD (USCG)  
HAZARD ANALYSIS PROJECT  
FINAL REPORT  
(TASK 5)**

***DETAILED HAZARD ANALYSIS OF  
WMEC-270 SMALL BOAT OPERATIONS***

Vernon H. Guthrie  
Dale F. Nawrocki  
David A. Walker  
Thomas F. Zanin

**JBF Associates, Inc.  
1000 Technology Drive  
Knoxville, TN 39732-3353**

July 31, 1996

This work is being performed for the United States Coast Guard under Delivery Order DTCG39-95-F-E00315 of Contract Number DTCG39-95-D-E00395

## ***D.1 INTRODUCTION***

Performing U.S. Coast Guard (USCG) missions at sea requires launching and recovery of a vessel's small boats. USCG missions such as search and rescue (SAR), enforcement of laws and treaties (ELT), marine environmental response (MER), defense operations (DO), general emergencies, and logistical support (routine operations) involve using small boats. The commanding officer (CO) must carefully weigh the urgency of each mission and assess the benefits and risks involved. Although the CO may consult with experienced shipboard personnel when deciding to launch a small boat, the CO is still ultimately responsible for the decision.

Small boat operations require a high degree of skill, training, and coordination on the part of the bridge officers, deck crew, boat coxswain, and boat crew. Situations are encountered where a mission requires using a small boat in rough weather conditions. In these situations, the CO must assess the risks of conducting boat operations. This assessment can include considering factors such as urgency of mission, wave shape and period, sea state, wind, visibility, temperature, experience of the small boat crew and deck personnel, fatigue, duration of the mission, transit distance for the mission, and potentially changing weather conditions. Due to the many variables involved, no absolute standards exist governing launch/recovery decisions.

## ***D.2 OBJECTIVES***

The coarse hazard analysis of the WMEC-270 vessel class identified various elements of small boat operations as potentially high risk evolutions (small boat activities once away from the host vessel were not included in the coarse hazard analysis). The coarse hazard analysis analyzed 21 different deviations (i.e., upset conditions from normal operations) for small boat operations, which focused on the launch and recovery segments for motor surf boats (MSBs) and rigid hull inflatable boats (RHIs). The coarse hazard analysis calculated risk index numbers for each deviation. Risk index numbers account for deviational frequencies (likelihoods of occurrence) and consequences (mishaps) and thus are a relative measure of risk significance. Higher risk index numbers indicate higher risks. In addition to assigning frequency scores and calculating risk index numbers, the coarse hazard analysis teams also characterized their confidence in their assessments as either High, Medium, or Low.

Two of the small boat deviations were ranked in the top 10 most significant deviations for the WMEC-270 coarse hazard analysis and both were in the top 7 deviations. These two deviations were both attributed to MSB operations: loss of support and excessive sway during lowering/raising. The coarse hazard analysis team assigned a low certainty to its assessment of the loss of support deviation and a high certainty to the excessive sway deviation.

The objectives of this study were to further analyze small boat operations to (1) understand and identify the contributors to a high risk operation that lead to consequences of interest (determined during the coarse hazard analysis), (2) recommend ways for reducing the risks associated with the identified hazards, and (3) increase the coarse hazard analysis's initial estimates of certainty. A fourth objective particular to this study (versus an objective for detailed hazard analysis in general) was to verify the level of accuracy realized from implementing the coarse hazard analysis methodology in characterizing vessel hazards (small boat operations in this case). The coarse hazard analysis methodology was designed as a first pass attempt at assessing vessel hazards, and more detailed study should provide feedback on the accuracy of that effort.

### ***D.3 SCOPE***

The detailed analysis covered bridge functions, deck level functions, bridge-to-deck communications, and bridge-to-boat communications during small boat launch and recovery evolutions. Both MSB and RHI operations and associated launch/recovery hardware systems were included in the study. Daily small boat checks performed by Engineering and Deck Division were also included. Maintenance practices for small boats and launch/recovery systems, although recognized in the study, were not specifically analyzed. The analysis did not account for events once a small boat was away from the vessel.

### ***D.4 SYSTEM DESCRIPTION***

The following is a brief summary of vessel small boats, bridge responsibilities, and launch/recovery systems.

#### ***D.4.1 Small Boats***

**Motor Surf Boat:** MSBs are highly capable boats whose rugged construction and self-bailing features contribute to the ability to withstand adverse weather conditions. These boats have more cargo carrying capability (i.e., can carry more people or equipment) than RHIs and are more seaworthy in high sea states and high wind conditions. An MSB is propelled by a single diesel engine, which, although reliable once running, may be difficult to start in cold conditions. Also, MSBs are slower than RHIs and require more people to operate than RHIs. In spite of what the name implies, MSBs are not surf (i.e., breaking wave conditions) capable boats and should not be operated in surf conditions.



**Rigid Hull Inflatable Boat:** RHIs are fast, maneuverable boats that are easy to launch/recover and facilitate missions in which transit speed is a main factor. RHIs are also self-bailing. The rubber inflated pontoon surrounding the RHI serves as a cushion when maneuvering it near other vessels and/or fixed objects. All RHIs are propelled by twin gasoline outboard engines. In general, however, RHIs do not afford adequate crew protection from breaking seas. RHI systems such as fuel tanks, steering, and dewatering are sometimes not adequate for the rigors of heavy weather operations.

**Boat Checks:** Each morning while underway, both the MSB and the RHI are checked for readiness by crew members from Deck Division and Engineering. Each has an associated checklist. The completed Engineering checklist goes to the Officer of the Deck. The completed Deck Division checklist goes to the Deck Division Leading Petty Officer. These status checks are one factor when determining which small boat is the "Ready Boat" for the day. Other factors, such as anticipated mission requirements, influence selection of the "Ready Boat," which is the first boat launched for rapid mission responses unless otherwise directed by the CO. The Engineering checklist and the Deck Division checklists for the MSB and RHI are found in Attachment A, along with copies of the MSB and RHI launch/recovery procedures.

#### *D.4.2 Bridge Responsibilities*

The bridge has key functions during small boat operations, especially in the lowering/recovery segments. After the CO decides to proceed with small boat operations, the bridge is responsible for establishing a safe launch (and recovery) course and speed. During both launch and recovery, the vessel should be maneuvered into a position that provides the best lee conditions (conditions on the sheltered side of the vessel away from the direction of the winds and seas), minimizes transit duration and distance, and minimizes pitch and roll while taking into account nearby navigation hazards, shipping density, and environmental factors. The vessel normally maintains constant speed and heading throughout launch/recovery unless (1) minor adjustments are needed to provide better lee conditions or (2) major changes are needed in an emergency situation (i.e., fishing boat cuts in front of the vessel).

Overall, the evolution is controlled from the bridge by the Deck Officer, who is positioned on either the port bridge wing (for RHI operations) or the starboard bridge wing (for MSB operations). The bridge grants permission for the following steps: MSB Launch — put the boat to the rail, load the boat, and lower the boat; RHI Launch — put the boat to the rail and lower the boat. During recovery, the bridge grants permission to the boat coxswain to come alongside the vessel for recovery. At all points during launch/recovery, the bridge is in communication with the deck and the coxswain through hand-held radios. Once away from the vessel, the bridge communicates directly with the coxswain. As a backup, sound-powered phone circuits (communications circuits) link the bridge and the deck, and hand signals can be passed from the deck to the coxswain.

### ***D.4.3 Launch and Recovery Systems***

Each small boat has a dedicated launch/recovery system. Deck Division personnel are responsible for manning and operating the launch/recovery systems. Engineering personnel are responsible for maintaining mechanical and electrical systems on the small boats and on the launch/recovery systems. Table D.1 lists the manning requirements for MSB and RHI launch/recovery evolutions. As stated earlier, Appendix D.1 contains copies of the MSB and RHI launch/recovery procedures. Also, the MSB and RHI launch/recovery evolutions were broken down into distinct action item steps to facilitate the analysis. Table D.2 and Table D.3 list equipment status and personnel involvement respectively for each distinct step for MSB operations. Table D.4 and Table D.5 show the same information for RHI operations.

**Table D.1 Small Boat Manning Requirements**

<b>Position</b>	<b>MSB</b>	<b>RHI</b>
Deck Officer	X	X
Deck Supervisor	X	X
Safety Supervisor	X	X
Coxswain	X	X
Boat Engineer	X	X
Boat Crewman	X	
Sea Painter Tender	X	X
Frapping Line Tender, FWD	X	X
Frapping Line Tender, AFT	X	X
Boom/Winch Operator	X	
Articulating Crane Operator		X

Table D.2 MSB Equipment Status at Each Procedure Step

Procedure Step	Gripe Straps	Davit Pins	Davit Shoes	Davit Arms	Winch Cable	Fall Blocks	MSB	MSB Engine	Sea Painter
1 -- Perform small boat checks before operations	Secure	Engaged	Engaged	Locked in	Reeled in	Hooked	Cradled	Off	Hooked
2 -- Decide to launch a small boat									
3 -- Decide to use the MSB instead of the RHI									
4 -- Man the MSB launch stations									
5 -- Ungripe the MSB	Released								
6 -- Release the shoes			Released						
7 -- Remove the pins		Removed		In					
8 -- Move the MSB outboard				Extended out			Hanging		

Table D.2 MSB Equipment Status at Each Procedure Step (cont'd)

Procedure Step	Gripe Straps	Davit Pins	Davit Shoes	Davit Arms	Winch Cable	Fall Blocks	MSB	MSB Engine	Sea Painter
9 — Tend the MSB frapping lines									
10 — Lower the MSB to the rail					Spooled to rail		Hanging at rail		
11 — Snug the MSB against the rail				Adjusted to snug MSB			Hanging at rail — Snugged		
12 — Load/Man the MSB									
13 — Man the MSB monkey lines									
14 — Establish MSB launch course/speed									
15 — Swing the MSB clear of the hull				Extended away from hull			Hanging — Loaded		
16 — Lower the MSB					Spooling to lower MSB				

Table D.2 MSB Equipment Status at Each Procedure Step (cont'd)

Procedure Step	Gripe Straps	Davit Pins	Davit Shoes	Davit Arms	Winch Cable	Fall Blocks	MSB	MSB Engine	Sea Painter
17 — Retrieve the monkey lines					Spooled to water		In water — Under fall lines		
18 — Start the MSB engine								On	
19 — Release the MSB from the falls						Released			
20 — Control the blocks					Spooled to recovery position				
21 — Maneuver the MSB away from the vessel and forward							Away from vessel — on sea painter		
22 — Release the sea painter						Away from vessel			Released
23 — Prepare the sea painter for passing									Prepared on deck for passing

Table D.2 MSB Equipment Status at Each Procedure Step (cont'd)

Procedure Step	Gripe Straps	Davit Pins	Davit Shoes	Davit Arms	Winch Cable	Fall Blocks	MSB	MSB Engine	Sea Painter
24 — Man the MSB recovery stations									
25 — Provide enough slack in the falls for rapid MSB recovery					Spooled to water				
26 — Establish MSB recovery course/speed									
27 — Maneuver the MSB alongside the vessel							Near vessel		
28 — Pass the sea painter							Away from vessel — On sea painter		Hooked
29 — Position the MSB directly under the fall lines							Under fall lines		

Table D.2 MSB Equipment Status at Each Procedure Step (cont'd)

Procedure Step	Gripe Straps	Davit Pins	Davit Shoes	Davit Arms	Winch Cable	Fall Blocks	MSB	MSB Engine	Sea Painter
30 — Man the monkey lines									
31 — Connect fall lines to MSB						Hooked			
32 — Stop the MSB engine								Off	
33 — Raise the MSB to the rail					Spooling to raise MSB		Hanging — Loaded		
34 — Snug the MSB against the rail				Adjusted to snug MSB	Spooled to rail		Hanging at rail — Snugged		
35 — Unload/Unm an the MSB									
36 — Raise the MSB				Extended out	Reeled in		Hanging		
37 — Bring the MSB inboard				Swung in					

Table D.2 MSB Equipment Status at Each Procedure Step (cont'd)

Procedure Step	Gripe Straps	Davit Pins	Davit Shoes	Davit Arms	Winch Cable	Fall Blocks	MSB	MSB Engine	Sea Painter
38 — Cradle the MSB				In			Cradled		
39 — Set the shoes			Engaged						
40 — Set the pins		Engaged		Locked in					
41 — Gripe the boat	Secured								
42 — Secure and store all gear									



Table D.3 MSB Personnel Status at Each Procedure Step

Procedure Step	CO	Deck Officer	Safety Supv.	Deck Supv.	Boom / Winch Oper.	Frapping Line Tenders	Sea Painter Tender	Coxn.	Boat Crewman	Boat Engineer
1 — Perform small boat checks before operations				X*						X*
2 — Decide to launch a small boat	X									
3 — Decide to use the MSB instead of the RHI	X	X								
4 — Man the MSB launch stations		X	X	X	X	X	X	X	X	X
5 — Ungripe the MSB			X	X		X		X	X	X
6 — Release the shoes		X**	X	X		X				
7 — Remove the pins			X	X		X				

\* Performed by someone in Deck Division or Engineering.

\*\* After the Deck Officer grants permission to move the MSB to the rail, releasing the shoes is the next step.

Table D.3 MSB Personnel Status at Each Procedure Step (cont'd)

Procedure Step	CO	Deck Officer	Safety Supv.	Deck Supv.	Boom / Winch Oper.	Frapping Line Tenders	Sea Painter Tender	Coxn.	Boat Crewman	Boat Engineer
8 — Move the MSB outboard			X	X	X	X				
9 — Tend the MSB frapping lines			X	X		X				
10 — Lower the MSB to the rail			X	X	X	X				
11 — Snag the MSB against the rail			X	X	X	X				
12 — Load/Man the MSB		X	X	X				X	X	X
13 — Man the MSB monkey lines			X	X				X	X	X
14 — Establish MSB launch course/speed	X	X								
15 — Swing the MSB clear of the hull		X	X	X	X	X				
16 — Lower the MSB			X	X	X	X				
17 — Retrieve the monkey lines			X	X		X		X	X	X

Table D.3 MSB Personnel Status at Each Procedure Step (cont'd)

Procedure Step	CO	Deck Officer	Safety Supv.	Deck Supv.	Boom / Winch Oper.	Frapping Line Tenders	Sea Painter Tender	Coxn.	Boat Crewman	Boat Engineer
18 — Start the MSB engine								X		X
19 — Release the MSB from the falls			X	X				X	X	X
20 — Control the blocks			X	X	X	X				
21 — Maneuver the MSB away from the vessel and forward			X	X			X	X		
22 — Release the sea painter			X	X			X	X	X	
23 — Prepare the sea painter for passing			X	X			X			
24 — Man the MSB recovery stations	X	X	X	X	X	X	X			
25 — Provide enough slack in the falls for rapid MSB recovery			X	X	X	X				

Table D.3 MSB Personnel Status at Each Procedure Step (cont'd)

Procedure Step	CO	Deck Officer	Safety Supv.	Deck Supv.	Boom / Winch Oper.	Frapping Line Tenders	Sea Painter Tender	Coxn.	Boat Crewman	Boat Engineer
26 — Establish MSB recovery course/speed	X	X								
27 — Maneuver the MSB alongside the vessel		X						X		
28 — Pass the sea painter			X	X			X	X	X	
29 — Position the MSB directly under the falls			X	X		X	X	X		
30 — Man the monkey lines			X	X				X	X	X
31 — Connect falls to the MSB			X	X		X		X	X	X
32 — Stop the MSB engine								X		X
33 — Raise the MSB to the rail			X	X	X	X				
34 — Snug the MSB against the rail			X	X	X					
35 — Unload/Unman the MSB			X	X				X	X	X

Table D.3 MSB Personnel Status at Each Procedure Step (cont'd)

Procedure Step	CO	Deck Officer	Safety Supv.	Deck Supv.	Boom / Winch Oper.	Frapping Line Tenders	Sea Painter Tender	Coxn.	Boat Crewman	Boat Engineer
36 — Raise the MSB		X	X	X	X	X				
37 — Bring the MSB inboard			X	X	X	X				
38 — Cradle the MSB			X	X	X	X				
39 — Set the shoes			X	X		X				
40 — Set the pins			X	X		X				
41 — Gripe the boat			X	X		X		X	X	X
42 — Secure and store all gear			X	X		X	X	X	X	X

Table D.4 RHI Equipment Status at Each Procedure Step

Procedure Step	Gripe Straps	Articulating Crane	Crane boom	Winch Cable	RHI	RHI Engine	Sea Painter	Frapping Lines
1 — Perform small boat checks before operations	Secure	Over the deck	Extended in	Reeled in	Cradled	Off	Hooked	Hooked
2 — Decide to launch a small boat								
3 — Decide to use the RHI instead of the MSB								
4 — Man the RHI launch stations								
5 — Ungripe the RHI	Released							
6 — Hook boom cable to metal ring		Over RHI cradle		Spooled to RHI cradle				
7 — Raise RHI onto J-hooks				Spooled to put RHI on J-hooks	Hanging on J-hooks			
8 — Swing RHI over the water		Over the water						
9 — Tend the sea painter								
10 — Tend RHI frapping lines								

Table D.4 RHI Equipment Status at Each Procedure Step (cont'd)

Procedure Step	Gripe Straps	Articulating Crane	Crane boom	Winch Cable	RHI	RHI Engine	Sea Painter	Frapping Lines
11 — Extend boom over the water			Extended out slightly					
12 — Lower RHI to the rail				Spooled to rail	Hanging at rail			
13 — Snug RHI against the rail			Adjusted to snug RHI		Hanging at rail — Snugged			
14 — Load coxswain and engineer into RHI								
15 — Establish appropriate launch course/speed								
16 — Swing RHI clear of the rail			Extended out slightly		Hanging — Loaded			
17 — Lower RHI to the water				Spooling to lower RHI				
18 — Start RHI engine				Spooled to water	In water	On		
19 — Release boom cable				Released				

Table D.4 RHI Equipment Status at Each Procedure Step (cont'd)

Procedure Step	Gripe Straps	Articulating Crane	Crane boom	Winch Cable	RHI	RHI Engine	Sea Painter	Frapping Lines
20 — Load passengers into RHI by Jacob's ladder				Spooled to recovery position				
21 — Release frapping lines								Released
22 — Maneuver RHI away from the vessel					Away from vessel on sea painter			
23 — Release the sea painter					Away from vessel		Released	
24 — Make sea painter ready for passing								Prepared on deck for passing
25 — Man RHI recovery stations								
26 — Establish appropriate recovery course/speed								
27 — Maneuver RHI alongside the vessel					Near vessel			
28 — Pass the sea painter							Hooked	



Table D.4 RHI Equipment Status at Each Procedure Step (cont'd)

Procedure Step	Gripe Straps	Articulating Crane	Crane boom	Winch Cable	RHI	RHI Engine	Sea Painter	Frapping Lines
29 — Maneuver RHI under the boom					Under boom			
30 — Pass frapping lines								Hooked
31 — Unload passengers by Jacob's ladder								
32 — Lower boom cable				Spooled to water				
33 — Hook up cable to metal ring				Hooked				
34 — Stop the RHI engine						Off		
35 — Raise RHI to the rail				Spooling to raise RHI	Hanging — Loaded			
36 — Snug RHI against the rail			Adjusted to snug RHI	Spooled to rail	Hanging at rail — Snugged			
37 — Unload coxswain and engineer								
38 — Raise RHI onto J-hooks			Extended in	Spooled to put RHI on J-hooks	Hanging on J-hooks			

Table D.4 RHI Equipment Status at Each Procedure Step (cont'd)

Procedure Step	Gripe Straps	Articulating Crane	Crane boom	Winch Cable	RHI	RHI Engine	Sea Painter	Frapping Lines
39 — Swing RHI over to cradle		Over RHI cradle						
40 — Lower RHI to cradle				Spooled to RHI cradle	Cradled			
41 — Unhook boom cable				Released				
42 — Secure boom cable				Reeled in				
43 — Gripe RHI to the cradle	Secure							
44 — Secure and store all gear								

Table D.5 RHI Personnel Status at Each Procedure Step

Procedure Step	CO	Deck Officer	Safety Supv.	Deck Supv.	Articulating Crane Oper.	Frapping Line Tenders	Sea Painter Tender	Coxn.	Boat Engineer
1 — Perform small boat checks before operations				X*					X*
2 — Decide to launch a small boat	X								
3 — Decide to use the RHI instead of the MSB	X	X							
4 — Man the MSB launch stations		X	X	X	X	X	X	X	X
5 — Ungripe the RHI			X	X		X		X	X
6 — Hook boom cable to metal ring			X	X	X	X			
7 — Raise RHI onto J_hooks		X	X	X	X	X			
8 — Swing RHI over the water			X	X	X	X	X		

\* Performed by someone in Deck Division or Engineering.

Table D.5 RHI Personnel Status at Each Procedure Step (cont'd)

Procedure Step	CO	Deck Officer	Safety Supv.	Deck Supv.	Articulating Crane Oper.	Frapping Line Tenders	Sea Painter Tender	Coxn.	Boat Engineer
9 -- Tend the sea painter			X	X			X		
10 -- Tend RHI frapping lines			X	X		X			
11 -- Extend boom over the water			X	X	X	X			
12 -- Lower RHI to the rail			X	X	X	X			
13 -- Snug RHI against the rail			X	X	X				
14 -- Load coxswain and engineer into RHI		X	X	X				X	X
15 -- Establish appropriate launch course/speed	X	X							
16 -- Swing RHI clear of the rail		X	X	X	X	X			
17 -- Lower RHI to the water			X	X	X	X			
18 -- Start RHI engine								X	X

Table D.5 RHI Personnel Status at Each Procedure Step (cont'd)

Procedure Step	CO	Deck Officer	Safety Supv.	Deck Supv.	Articulating Crane Oper.	Frapping Line Tenders	Sea Painter Tender	Coxn.	Boat Engineer
19 — Release boom cable			X	X				X	X
20 — Load passengers into RHI by Jacob's ladder			X	X		X		X	X
21 — Release frapping lines			X	X		X			X
22 — Maneuver RHI away from the vessel								X	
23 — Release the sea painter								X	X
24 — Make sea painter ready for passing							X		
25 — Man RHI recovery stations	X	X	X	X		X	X		
26 — Establish appropriate recovery course/speed	X	X							

Table D.5 RHI Personnel Status at Each Procedure Step (cont'd)

Procedure Step	CO	Deck Officer	Safety Supv.	Deck Supv.	Articulating Crane Oper.	Frapping Line Tenders	Sea Painter Tender	Coxn.	Boat Engineer
27 — Maneuver RHI alongside the vessel		X						X	
28 — Pass the sea painter			X	X			X	X	X
29 — Maneuver RHI under the boom			X	X			X	X	
30 — Pass frapping lines			X	X		X			X
31 — Unload passengers by Jacob's ladder			X	X		X		X	X
32 — Lower boom cable			X	X	X				
33 — Hook up cable to metal ring			X	X				X	X
34 — Stop the RHI engine								X	X
35 — Raise RHI to the rail			X	X	X	X			
36 — Snug RHI against the rail			X	X	X	X			

Table D.5 RHI Personnel Status at Each Procedure Step (cont'd)

Procedure Step	CO	Deck Officer	Safety Supv.	Deck Supv.	Articulating Crane Oper.	Frapping Line Tenders	Sea Painter Tender	Coxn.	Boat Engineer
37 — Unload coxswain and engineer			X	X				X	X
38 — Raise RHI onto J-hooks			X	X	X	X			
39 — Swing RHI over to cradle			X	X	X	X	X		
40 — Lower RHI to cradle			X	X	X	X			
41 — Unhook boom cable			X	X		X			
42 — Secure boom cable			X	X	X				
43 — Gripe RHI to the cradle			X	X		X		X	X
44 — Secure and store all gear			X	X	X	X	X	X	X

### D.4.3.1 Motor Surf Boat

**Hardware:** The MSB is controlled by a twin arm davit (boom) that moves inboard and outboard hydraulically. When cradled (stowed position), the MSB is held in place by two shoes (braces, one forward and one aft) and by a gripping strap that runs over the hull of the MSB, top to bottom, and attaches underneath the MSB. Two steel pins (one forward and one aft) lock the davit arms in place to prevent outward movement. Some COs prefer to operate at times with the davit arms partially extended so that the MSB is ready for loading and launching. However, this practice has two disadvantages: (1) even though a hydraulic lock on the davit may initially hold the MSB in place and ready for launch, the arms may extend (creep) outward after a few hours due to "leak by" on the hydraulic piston rams (from the weight of the MSB), which sets the MSB away from the launch deck; and (2) when extended, the chrome plating on the arms of the piston rams are exposed to a salt air environment, which accelerates corrosion. Figure D.1 and Figure D.2 show different views of the MSB davit/winch system.

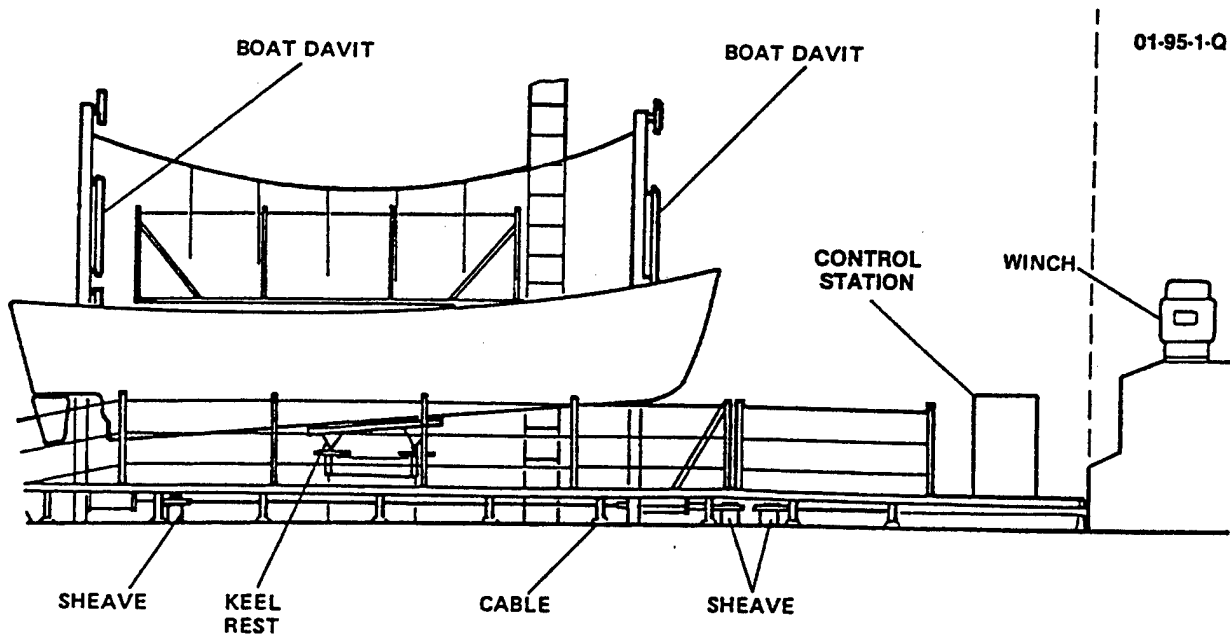

Figure D.1 MSB and Davit System (Side View)



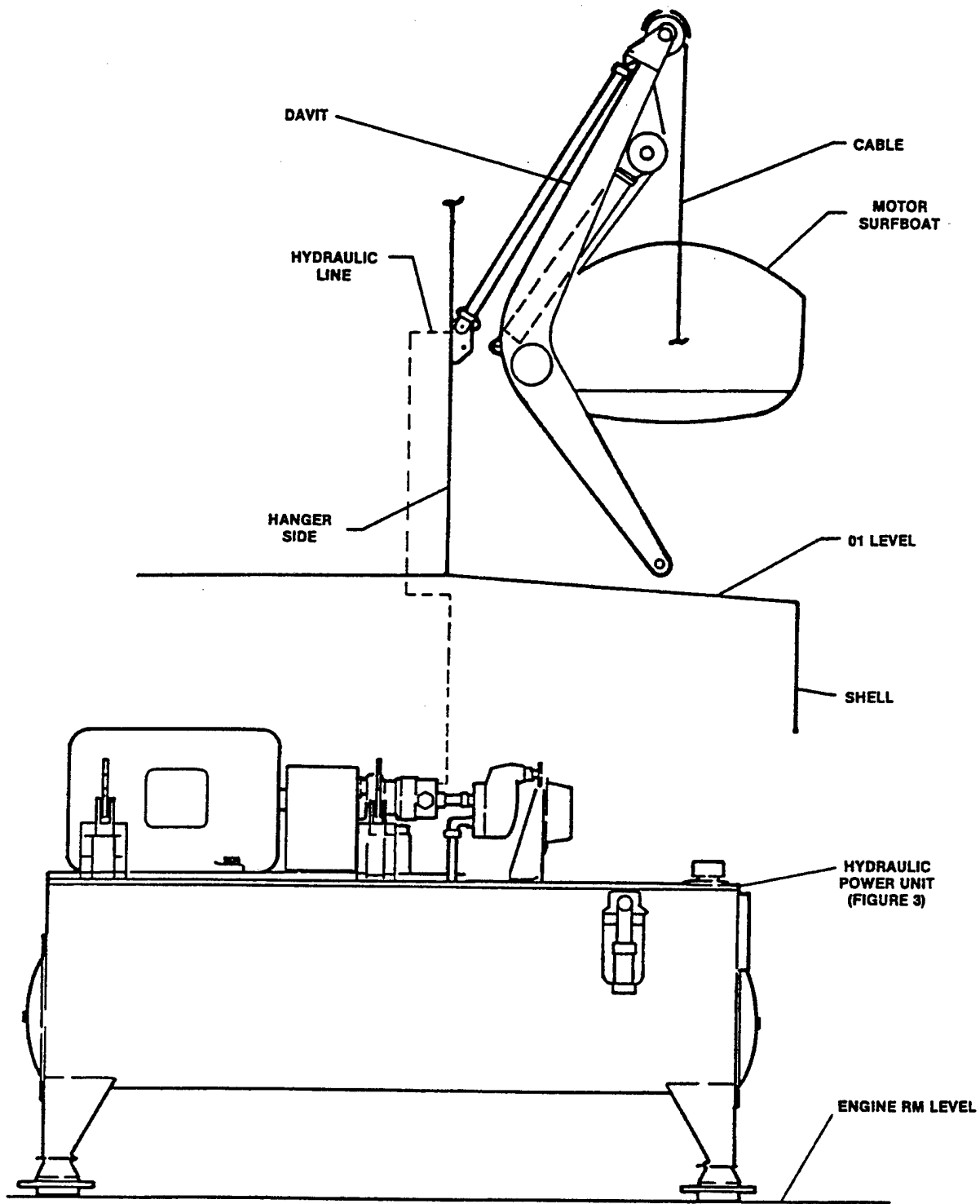

Figure D.2 MSB and Davit System (Rear View)

An electric winch raises and lowers the MSB. The winch drives two fall lines (cables) that run through each davit arm and attach by blocks fore and aft on the MSB. Separate lines, known as frapping lines, are also attached to the fall lines and are handled by frapping line tenders (deck crewman) to reduce sway while raising and lowering the MSB. While raising or lowering, boat crew members hold onto support lines, known as monkey lines, that attach to a cable that runs between the davit arms. The monkey lines not only give boat crew members support while raising or lowering the MSB, but also act as life lines if the MSB accidentally drops into the water (e.g., if one or both fall lines break).

Another line, known as the sea painter, provides additional boat control. This line is attached to the bow of the MSB and allows the MSB to be towed. It is the last line to be released during launching (i.e., released after the fall lines are released) and is the first line attached during recovery.

**Hydraulics:** The MSB davit has its own hydraulics system located in the engine room. A single pump drives the system. Both davit arms are operated as one unit. A manually operated backup pump is included in the system and can be operated by engine room personnel in an emergency. If hydraulic pressure is lost during operations due to a hose rupture, the davit arms are expected to move slowly to the fully extended position.

**Location:** On the WMEC-270 class vessels, the MSB davit system is located on the 01 level, starboard side at approximately midship. The davit and winch control station is located just forward of the MSB.

**Manning Requirements:** The Deck Officer and multiple deck personnel are involved in MSB operations. The deck evolution is controlled by a deck supervisor and monitored by a safety supervisor independent of the operation. Personnel other than those from Deck Division may be called on to support the evolution (i.e., control frapping lines and the sea painter). As stated earlier, Table D.1 lists the manning positions for MSB operations.

**Maintenance:** Moveable parts on the MSB davits are periodically greased and the hydraulics lines are periodically slushed (external surfaces cleaned). Every 2 years, the entire hydraulics system is overhauled.

#### **D.4.3.2 Rigid Hull Inflatable Boat**

**Hardware:** The RHI is controlled by an articulating crane that is hydraulically driven. Stationary J-hooks provide added control when moving the RHI (the RHI is moved in/out of the J-hooks) and the crane swivels to swing the RHI into position. A cable runs through a boom arm between the J-hooks for raising and lowering the RHI. The cable is operated by a hydraulic motor. When cradled, the

J-hooks are not connected to the RHI, which is secured by gripping straps to its cradle. After the gripping straps are released in preparation for launching, the boom cable attaches to a single metal ring, which has straps running from it to multiple points on the RHI for support when raising and lowering the RHI. Also, after the gripping straps are released, the RHI is raised up into the stationary J-hooks, which fit around the top starboard side pontoon of the RHI. This form of rigging provides support while the RHI is swung out over the water or while it is being swung back in during recovery. Figure D.3 shows the RHI articulating crane (J-Hooks not shown).

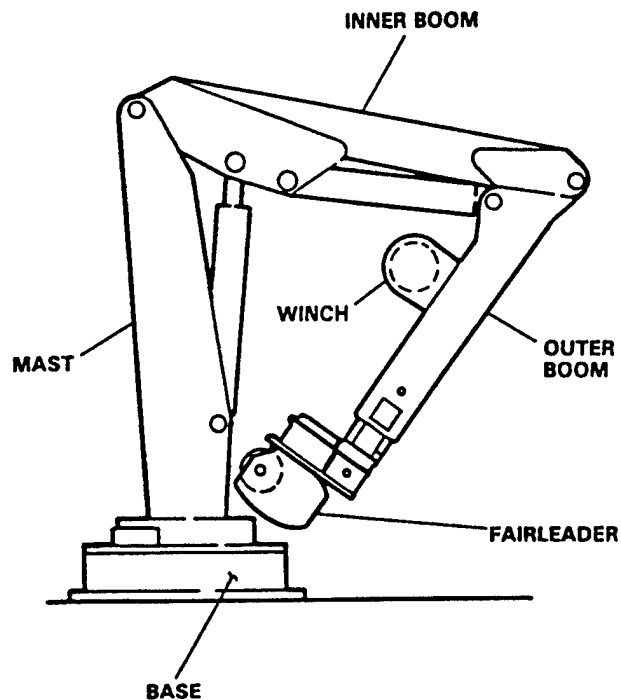

Figure D.3 RHI Articulating Crane

Once the RHI is over the water, the boom is extended enough to allow the RHI to be clear of the vessel's lifelines, and the boom cable lowers the boat from the grip of the J-hooks to the rail for loading the coxswain and engineer into the boat. After this, the boat is lowered to the water. Frapping lines (hooked up while the boat is on deck) are used to control sway of the RHI during launch and recovery. Like the MSB, the RHI is also towed by a sea painter line (hooked near the bow of the boat) for added control during launch and recovery. Additional boat passengers load and unload the RHI (once in the water) by a Jacob's ladder over the side of the vessel. The same hardware hooking features are used during recovery.

**Hydraulics:** The articulating crane has its own hydraulics systems located in the engine room. A single pump drives the system. A manually operated backup pump is included in the system and can be operated by deck personnel in an emergency. If hydraulic pressure is lost during operations due to a hose rupture, the boom is expected to move slowly downward, and the RHI would not drop very far to either the deck or the water.

**Location:** On WMEC-270 class vessels, the RHI articulating crane is located on the port side of the fantail. The control station is located just forward of it.

**Manning Requirements:** The Deck Officer and multiple deck personnel are involved in RHI operations. The deck evolution is controlled by a deck supervisor and monitored by a safety supervisor independent of the operation. Personnel other than those from Deck Division may be called

on to support the evolution (i.e., control frapping lines and the sea painter). As stated earlier, Table D.1 lists the manning positions for RHI operations.

**Maintenance:** Moveable parts on the articulating crane are periodically greased and the hydraulics lines are periodically slushed (external surfaces cleaned). Every 2 years, the entire hydraulics system is overhauled.

## ***D.5 APPROACH***

As part of the vessel safety program, the USCG is exploring the possibility of applying system safety concepts, including risk/hazard assessment techniques, to USCG vessel safety. Thus, the detailed hazard analysis was supported by using multiple assessment methods instead of just one. Each method provides a somewhat different means for systematically identifying hazards and developing meaningful risk reduction recommendations. The three methods used for this study were:

- Worker and Instruction Safety Evaluation (WISE) review
- Human error (error-likely situation) review
- Procedural review

A multidisciplinary team was assembled to identify and evaluate small boat hazards. The team was comprised of personnel with backgrounds in vessel operations, research and development, and risk/hazard analysis. The analysis lasted 2½ days and was conducted on an WMEC-270 cutter (USCG *LEGARE*, WMEC-912). Team members are listed in Table D.6.

### ***D.5.1 WISE Review***

The team used the WISE technique as one means for systematically identifying and evaluating evolution hazards. The WISE approach integrates the human factors aspects of process hazard analysis and job hazard (task) analysis. A WISE analysis involves three steps: (1) perform a task analysis to identify the required operator actions and their sequence, (2) identify operator and evolution hazards associated with each step, and (3) investigate ways to reduce or eliminate hazards, reduce their likelihood of occurrence, or mitigate their potential consequences. The key elements of the WISE review are defined by the following terms:

**Items** — distinct action item steps

**Deviations** — departures from the intended action

**Causes** — reasons why deviations might occur

**Consequences** — potential effects of the deviations

**Safeguards** — features or human actions designed to prevent the causes or mitigate the consequences of the deviations

**Actions** — recommendations for design or procedural changes

The WISE technique uses a set of guide words (WISEguides) as deviations. Table D.7 lists the guide words along with descriptions of their meanings. Although the guide words were developed for application within the petroleum and chemical processing industries, they are still applicable to USCG operations.

The team's WISE review is summarized in Attachment B (for MSB launch/recovery) and in Attachment C (for RHI launch/recovery).

**Table D.6 Detailed Hazard Analysis Team**

<b>Individual</b>	<b>Organization</b>
LCDR Alexander	<i>LEGARE</i> , Operations Officer
ENS Knull	<i>LEGARE</i> , First Lieutenant
BMC Ozzimo	<i>LEGARE</i> , Deck Division
LCDR Becker *	G-WKS-4
Mr. William Jones *	RDC
Mr. Leonard Kingsley	RDC
Mr. Vernon Guthrie	JBFA
Mr. David Walker	JBFA
Mr. Thomas Zanin	JBFA

\*Personnel present for the first day only.

**Table D.7 WISE Deviations**

<b>WISEguides</b>	<b>Meaning</b>
Missing	The written procedure does not describe an action taken during, or immediately before, the step being examined
Skip/part of	The worker skips this step (or some part of it) and performs the rest of the procedure correctly. Example: The worker skipped Step X (open lube oil valve), so the compressor burned up when it was started in Step Y
More	The worker does too much of the specified action or does it too quickly. Example: The worker opened the valve too quickly, causing a water hammer which ruptured the steam line
Less	The worker does too little of the specified action or does it too slowly. Example: The worker added too little catalyst (Step X), so pressure built up when feed was added in Step Y, overpressurizing the reactor with unreacted feed material
Out of sequence	The worker performs the steps in a different order than specified by the procedure, possibly as a short cut. Example: The worker added both reactants before starting the mixer
Other than/reverse	The worker performs some action other than the one specified in the procedure, usually because of confusion or haste. Examples: When reaching for the Valve X control switch, the operator grasped and actuated the adjacent switch for Valve Y. After reinstalling the motor, the electrician wired it to run in reverse
Caught in/on/by/between	The equipment entangles a body part or clothing, often because the machine guards are missing or inadequate. Example: The worker's arm was broken when it was caught on the spinning coupling
Struck by/contact by	The equipment or process material hits the worker. Examples: A forklift ran into a worker or box toppled off a forklift onto a worker. Acid splashed out of a vat into a worker's eyes
Contact with/struck against	The worker inadvertently touches or hits the process. Examples: The pipefitter hit an unprotected light bulb and was electrocuted. The worker hit his head on a low pipe

**Table D.7 WISE Deviations (cont'd)**

<b>WISEguides</b>	<b>Meaning</b>
Slip/trip/fall	The worker loses his/her grip or footing. Example: The worker dropped a wrench which punctured the top of the fiberglass tank
Stress/strain/fatigue	The worker is poorly positioned with respect to the equipment, must frequently repeat a motion, or is overloaded. Example: The worker must carry 50-pound bags up a ladder and empty them into a tank
Exposure to	The process or location creates an acutely or chronically dangerous work environment — fumes, vibration, noise, heat, radiation, etc. Example: The worker may be exposed to fumes when taking a sample
Process upset/malfunction	The process experiences an abnormal condition during this step of the procedure. Examples: The relief valve on Tank X discharges while the worker is checking the level on adjacent Tank Y. The belt breaks while the machine is being threaded
Layout/traffic/siting	The worker cannot approach or evacuate the area because of permanent or temporary obstructions. Example: The operator was run over as she sprinted from the control room to close an emergency isolation valve
Tools/equipment	The worker cannot perform the required actions because the necessary tools and equipment (including PPE) are not available. Example: The workers could not promptly isolate the release because the PPE cabinets were engulfed in the cloud

### ***D.5.2 Human Error (Error-Likely Situation) Review***

When contemplating ways to improve human performance, there are two basic types of errors that managers/supervisors must address: (1) errors whose primary causal factors are individual human characteristics unrelated to the work situation and (2) errors whose primary causal factors are related to the design of the work situation. The latter of these two items contributes in creating error-likely situations in the work environment. It has been found that approximately 80-85% of human errors result from the design of the work situation (the tasks, equipment, and environment), which managers/supervisors directly control.

To ensure broad coverage of human factors issues, the team consulted the information documented in *A Manager's Guide to Reducing Human Errors* (Chemical Manufacturers Association). This publication describes a number of work situations that influence creation of error-likely situations. Not all are applicable to every work environment. Each applicable work situation was characterized by identifying (1) key areas of applicability within small boat operations, (2) strengths and weaknesses in current practices, (3) related coarse hazard analysis deviations, and (4) recommendations, if any, to address the weaknesses. Attachment D summarizes the assessment of error-likely situations. Table D.8 lists the error-likely situations:

**Table D.8 Error-Likely Situations**

<ul style="list-style-type: none"><li>• Deficient procedures</li><li>• Inadequate, inoperative, or misleading instrumentation</li><li>• Insufficient knowledge</li><li>• Conflicting priorities</li><li>• Inadequate labeling</li><li>• Inadequate feedback</li><li>• Policy/practice discrepancies</li><li>• Disabled equipment</li><li>• Poor communication</li><li>• Poor layout</li></ul>	<ul style="list-style-type: none"><li>• Violations of populational stereotypes</li><li>• Overly-sensitive controls</li><li>• Excessive mental tasks</li><li>• Opportunities for error</li><li>• Inadequate tools</li><li>• Sloppy housekeeping</li><li>• Extended, uneventful vigilance</li><li>• Computer control failure</li><li>• Inadequate physical restrictions</li><li>• Appearance at the expense of functionality</li></ul>
---	--



### ***D.5.3 Procedural Review***

The *LEGARE* has deck procedures governing launch/recovery of small boats (see Attachment A). These procedures are mainly used for training purposes. Due to the attention demands imposed on deck personnel during small boat launch/recovery, the procedures are not physically located on the boat decks during these evolutions.

In general, effective procedures should be useable, provide all critical information, agree with training documents, and be up-to-date. Based on discussions with *LEGARE* personnel and on information gained during the WISE review, the deck operating procedures were reviewed for effectiveness. Subsequently, most critical information was found to exist in the launch/recovery procedures and it was assumed that the procedures agree with shipboard training requirements and are current. The format was further reviewed for potential useability upgrades.

Procedural formats vary depending on how procedures are used in the work environment. Different formats exist for presenting procedural information in the most efficient and effective manner. Considering that training is the primary use of small boat procedures, an attempt was made at reformatting one segment of the procedures (launching the MSB) to make it more training-useable. Attachment E contains the new suggested format. *The new suggested format is based on procedure Deck Standing Order #2, MSB Lowering and Hoisting Procedures (from the LEGARE), which is found in Attachment A. The information contained in the new suggested format was not created by, nor is it necessarily endorsed, by JBFA.*

### ***D.6 RESULTS***

The USCG uses several procedural and design features in its small boat operations that either (1) prevent mishaps of concern from occurring or (2) limit the severity of mishaps of concern. Numerous elements positively affecting operator safety are found in the design of small boats and launch/recovery systems and in small boat procedures and practices. However, small boat operations still are considered among the higher risk evolutions performed in the USCG.

Based on the results and insights gained from performing this detailed hazard analysis, the team identified ways to improve personnel and equipment safety during small boat operations. The suggestions include both procedural and physical design changes. Documentation for this report's core analyses is found in the attachments, which are summarized as follows:

Attachment B — Motor Surf Boat (MSB) WISE Worksheets

Attachment C — Rigid Hull Inflatable Boat (RHI) WISE Worksheets

Attachment D — Human Factors (Error-Likely Situations) Review Worksheets

Attachment E — Procedural Format Upgrade for Launching a Motor Surf Boat (MSB)

## **D.7 RECOMMENDATIONS FOR SYSTEM IMPROVEMENT**

The following are recommendations for reducing personnel and equipment risk incurred during small boat operations. Recommendations are broken out as common and specific to both MSB and RHI operations. No significance should be placed on the order in which the recommendations appear. These recommendations are strictly the suggestions of the analysis team. Past USCG studies may already address the identified risks. There may also exist more effective ways for protecting against hazards, and some recommendations may not be practical or cost effective.

*If the recommendations of this study are followed, the frequency and/or consequences of small boat mishaps should decrease; however, even if all the recommendations are followed, small boat mishaps may still occur on USCG WMEC-270 vessels. In addition, the physical act of implementing these recommendations may create hazards for USCG personnel. Therefore, the USCG should independently evaluate the recommendations made in this study (and alternatives to them) to ensure that implementing them will not create new hazards and that safe practices are followed when any change is implemented. JBF Associates, Inc. accepts no liability for any small boat mishap that occurs on USCG vessels even if all the recommendations resulting from this study are implemented.*

### **D.7.1 Recommendations Common to Both MSB and RHI Operations**

**Recommendation 1 — Consider documenting the factors (with supporting guidance) used to make go/no-go decisions for launching small boats.** Decisions on whether or not to launch small boats are currently based on the judgment and experience of commanding officers and those advising them. Overall, this approach has served the USCG well. Vessel crews must account for factors such as weather and sea conditions, rate of change in current conditions, mission urgency, expected mission duration, experience and proficiency of boat crews and launch/recovery details, and fatigue when deciding whether to launch a small boat. However, USCG personnel are typically mission-success-oriented, which sometimes leads to accepting higher levels of risk when performing USCG missions. Developing go/no-go guidance for launching small boats (perhaps in the form of a decision flowchart or matrix) may reduce some of the risk associated with small boat operations in addition to providing a degree of standardization in USCG vessel decision making.

**Recommendation 2 — Consider documenting the factors (with supporting guidance) used to select between the MSB and the RHI.** Although small boat design limits are published and exist

onboard USCG vessels, the limits are rarely the only criteria referenced when deciding between the MSB and the RHI. The factors listed in Recommendation 1 also have a bearing on which small boat to send on a mission. Developing guidance for selecting which small boat to launch (perhaps in the form of a decision flowchart or matrix) places all these factors into perspective and may reduce some of the risk associated with small boat operations in addition to providing a degree of standardization in USCG vessel decision making.

***Recommendation 3 — Consider enhancing small boat launch precautionary statements to include verification of small boat physical conditions (engineering and deck conditions) prior to launch.*** Daily Engineering and Deck Division small boat checks are crucial to ensuring the continued operational and safety readiness of vessel small boats. Loose small boat safety gear, low fuel levels, or intense operational schedules (i.e., no time to complete the checks) are all example indicators that the checks have not been performed. Although completion of these checks is not the responsibility of the launch/recovery detail, it is prudent to verify that the checks have been done if it is suspected that they have not. A precautionary statement in the launch procedures to include verification of small boat physical conditions (engineering and deck conditions) prior to launch lowers the chances of sending a small boat out without ensuring operability and safety.

Currently, the completed Engineering small boat checksheet is sent to the Officer of the Deck (OOD) and the completed Deck Division small boat checksheet is sent to the Deck Division Leading Petty Officer (LPO). To allow faster responses to inquiries on the status of small boat checks, consideration should also be given to placing a copy of the completed Deck Division small boat checksheet with the OOD.

***Recommendation 4 — Consider adding a visual aid to indicate when the MSB/RHI has been breasted out to the correct position prior to putting it to the rail.*** Installing some form of visual aid (such as colored markings) for marking the proper distance to breast out a small boat helps ensure that the boat moved the correct distance the first time. Not moving a small boat out far enough may lead to damage when lowering it, and moving it out too far requires time to correct the position. In either case, the boat's position must be corrected, which takes time during the launch and leaves the small boat suspended in the air longer (more susceptible to sway and increased mission response time).

***Recommendation 5 — Consider having deck/boat crews wear cranial protection of a wraparound design instead of hard hats.*** Hard hats provide protection when in place. However, hard hats do not provide complete protection to the lower back parts of the cranium and can easily lose position (or fall off) when a person is hurried or bumped. Unfortunately, this can occur at a critical moment when head protection is most needed. Deck and boat crews should

be outfitted with some type of wraparound design that provides more cranial protection and is less likely to move around or fall off than are hard hats. Similar designs are currently used by USCG motor lifeboat crews in heavy surf conditions.

***Recommendation 6 — Consider reformatting vessel operational procedures to a more training-useable format.*** A revamped procedure format (example is enclosed) should segregate actual procedure steps from supplementary safety and emergency action information. This allows the reader (1) to easily follow the sequence of events in the procedure and (2) to readily reference important supporting information for each procedural step. Both features enhance the ability to use the procedures as effective training tools, which helps lower the risk of small boat operations. In addition, the format is easy to update.

***Recommendation 7 — To reduce the effects of fatigue, the USCG should consider (1) increasing the number of deck division billets onboard larger cutters or (2) providing definitive guidance outlining reasonable levels-of-effort expected from USCG vessels when fulfilling mission requirements.*** Fatigue while underway was found to be a large factor influencing crew performance. Crew members tend to become less rigorous about safety requirements following prolonged periods of hectic vessel operations. USCG missions often utilize Deck Division resources (search and rescue, small boat operations, flight operations, etc.) and increasing the number of such billets would spread the workload over more people. If this is not possible, the USCG should consider developing guidelines outlining how far a vessel's crew is expected to go (human endurance) when fulfilling USCG mission obligations.

#### ***D.7.2 Recommendations for MSB Operations***

***Recommendation 8 — Consider adding a precautionary statement to the MSB launch/recovery procedure to warn of the hazards of missing deck plating under the MSB.*** If the deck plating under the MSB is not in place, deck crew members tend to place themselves in vulnerable positions when releasing the MSB gripe straps. At this point, the tension held on the metal link (attached to the deck) is released and the link snaps back, possibly striking the deck crew member who just released it. Therefore, when manning the MSB launch detail, the deck plates under the MSB should be checked. If not present, the Safety Supervisor should decide a proper course of action at that point.

***Recommendation 9 — Consider installing a lip on the side of the vessel at the MSB boat deck to ensure that the MSB does not lose its grip while snugged to the hull when loading/unloading the boat crew and passengers.*** When placing the MSB against the hull (snugging it to the hull) in preparation for loading/unloading, the Deck Supervisor orders a slight inboard canter on the MSB to facilitate loading/unloading. In this position, the MSB rests on the rubber coating

surrounding the gunwale and is susceptible to slipping free. If this occurs, boat crewman or passengers may slip, trip, or fall (or go overboard) while loading or unloading. Installing a metal or wooden lip on the side of the hull at the boat deck could allow the deck crew to wedge the MSB in place and reduce the chance of the MSB losing its grip at a critical moment.

**Recommendation 10** — *Consider using a quick release/easy hook-up fastening mechanism for the end of the sea painter line.* Currently, the sea painter line attached to the MSB is held in place by a wooden peg (a fid). The forward boat crewman must be careful when releasing the fid (and when hooking it up) to not get his/her hands or fingers caught between the sea painter and the link attached to the MSB. An attaching mechanism that is both easy to release and hook-up should reduce the chance of personnel injury while releasing and attaching the sea painter.

**Recommendation 11** — *Consider upgrading the MSB recovery procedure to include setting the davit arm pins back in place.* Although this action is done when securing the MSB davit arms, it is not in the deck procedure. If it is overlooked, the unsecured davit arms may move while underway and damage the MSB. Adding this step to the procedure enhances its effectiveness as a training tool.

#### **D.7.3 Recommendations for RHI Operations**

**Recommendation 12** — *Consider extending the length of the port bridge wing to allow an increased view of RHI operations.* Under the existing layout, the OOD, who is controlling the RHI launch/recovery operation from the bridge, cannot see the RHI or the deck crew's actions while the RHI is positioned over the fantail (the OOD can see the RHI when it is over or in the water). Without this view, the OOD has limited opportunities to correct or warn the deck crew of potentially dangerous situations that the Safety Supervisor or Deck Supervisor may not notice. Extending the port bridge wing out should provide the OOD an expanded view of RHI operations and allow an extra set of eyes to monitor evolution safety. There are, however, practical limits to how far the wing can be extended.

**Recommendation 13** — *Consider adding a step to the RHI launch procedure that directs the boom cable to be hooked to the metal ring attached to the supporting straps.* Although this action is done when launching the RHI, it is not in the deck procedure. Adding this step to the procedure enhances its effectiveness as a training tool.

**Recommendation 14** — *Consider adding a step to the RHI recovery procedure to ensure that all gear is secured and stored.* Although this action is done when launching/recovering the RHI, it is not in the deck procedure. Adding this step into the procedure enhances its effectiveness

as a training tool and lowers the chance of forgetting gear topside after the evolution. This step is currently in the MSB deck procedure.

As was done for the coarse hazard analysis recommendations, the above recommendations are summarized according to their impacts on related coarse hazard analysis deviations. The coarse hazard analysis team characterized the risk associated with each deviation by assigning likelihood scores to mishap categories (Class A/B and Class C/D). Using the scores, risk index numbers were calculated. The risk index numbers are a relative measure of the risk significance of the possible outcomes from the various deviations. Higher risk index numbers indicate higher risks. More explanation on likelihood scores, mishap categories, and risk index numbers is found in the report *Preliminary Hazard Analysis Methodology (Interim Report for Task 3 — Working Document for Final Report)*. Note that since this report was issued, Figure 3.2, Likelihood Scoring Definitions, has been slightly revised. Figure D.4 shows the new likelihood scoring categories. The original coarse hazard analysis results are still considered valid when accounting for these new likelihood scoring categories.

Table D.9 summarizes each recommendation according to associated coarse hazard analysis small boat deviations (not WISE deviations), each deviation's initial risk index number, an estimate of the revised risk index number if the recommendation were implemented, the certainty of the revised risk characterization, and any explanatory notes.

Table D.10 summarizes for each coarse hazard analysis small boat deviation addressed by a recommendation the associated recommendations, the deviation's initial risk index number, an estimate of the revised risk index number if all recommendations were implemented, the certainty of the revised risk characterization, and any explanatory notes.

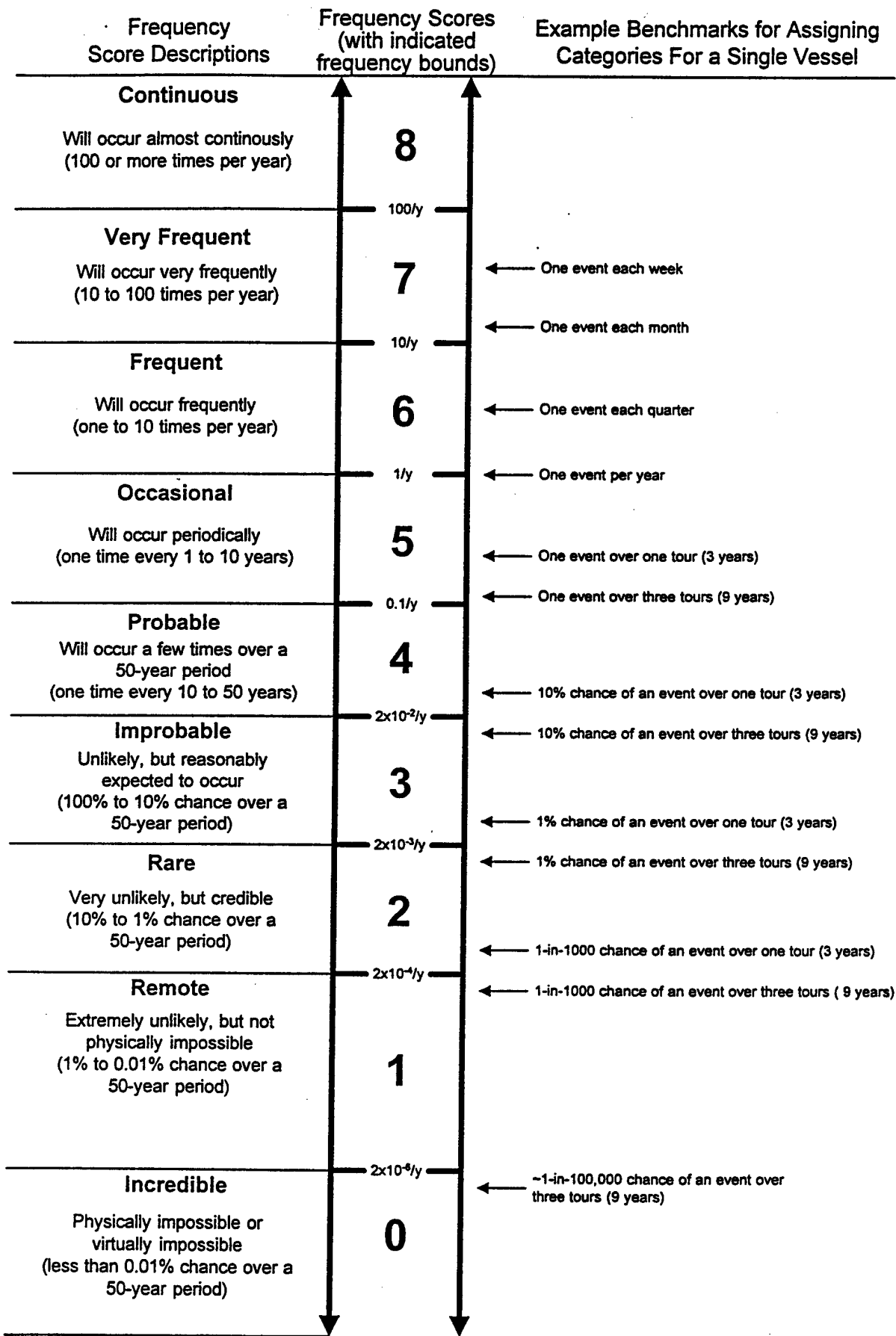

e:\data\jbfa-rpt\1010194\daw-01.vsd

Figure D.4 Likelihood Scoring Categories

**Table D.9 Estimated Impact of Recommendations on Related Coarse Hazard Analysis Deviations**

Recommendations	Associated Coarse Hazard Analysis Deviations	Initial Risk Index Number	Revised Risk Index Number	Certainty in Revised Risk Index Number	Notes
<i>Recommendation 1 — Consider documenting the factors (with supporting guidance) used to make go/no-go decisions for launching small boats</i>	All small boat deviations (Section 8 in Table B.1A)	--	*	*	Any changes in the risk profile will not be known until further evaluation is completed
<i>Recommendation 2 — Consider documenting the factors (with supporting guidance) used to select between the MSB and the RHI</i>	All small boat deviations (Section 8 in Table B.1A)	--	*	*	Any changes in the risk profile will not be known until further evaluation is completed

-- Not applicable

\* Further review required to reasonably assess any risk reduction potential



Table D.9 Estimated Impact of Recommendations on Related Coarse Hazard Analysis Deviations (cont'd)

Recommendations	Associated Coarse Hazard Analysis Deviations	Initial Risk Index Number	Revised Risk Index Number	Certainty in Revised Risk Index Number	Notes
<b>Recommendation 3 —</b> <i>Consider enhancing small boat launch precautionary statements to include verification of small boat physical conditions (engineering and deck conditions) prior to launch</i>	Slow speed/power of small boat (alongside vessel) (MSB and RHI) (Item 8.19 in Table B.1A)	8 (1,3)	7 (1,2)	Low	Some risk reduction realized, but the deviation is human-error-dominated
	Movement in the wrong horizontal direction — MSB (Item 8.14 in Table B.1A)	8 (1,3)	7 (1,2)	Medium	
<b>Recommendation 4 —</b> <i>Consider adding a visual aid to indicate when the MSB/RHI has been breasted out to the correct position prior to putting it to the rail</i>	Movement in the wrong horizontal direction — RHI (Item 8.15 in Table B.1A)	8 (1,3)	7 (1,2)	Medium	Should lower the number of actual movements and provide a defined target for adjusting small boat horizontal positions

-- Not applicable

\* Further review required to reasonably assess any risk reduction potential

Table D.9 Estimated Impact of Recommendations on Related Course Hazard Analysis Deviations (cont'd)

Recommendations	Associated Course Hazard Analysis Deviations	Initial Risk Index Number	Revised Risk Index Number	Certainty in Revised Risk Index Number	Notes
<i>Recommendation 5 — Consider having deck crews wear cranial protection of a wraparound design instead of hard hats</i>	Loss of support — MSB (Item 8.1 in Table B.1A)	13 (2,3)	7 (1,2)	Medium	Recommendation has greatest effect on deviations in which the boat crew could experience a large physical impact
	Loss of support — RHI (Item 8.2 in Table B.1A)	8 (1,3)	7 (1,2)	Medium	
	Lowering too quickly — MSB (Item 8.4 in Table B.1A)	8 (1,3)	7 (1,2)	Low	
	Lowering too slowly — MSB (Item 8.6 in Table B.1A)	9 (1,4)	8 (1,3)	Low	
	Raising too quickly — MSB (Item 8.8 in Table B.1A)	8 (1,3)	7 (1,2)	Low	

-- Not applicable

\* Further review required to reasonably assess any risk reduction potential

**Table D.9 Estimated Impact of Recommendations on Related Coarse Hazard Analysis Deviations (cont'd)**

Recommendations	Associated Coarse Hazard Analysis Deviations	Initial Risk Index Number	Revised Risk Index Number	Certainty in Revised Risk Index Number	Notes
<i>Recommendation 5 (cont'd)</i>	Raising too quickly — RHI (Item 8.9 in Table B.1A)	8 (1,3)	8 (1,3)	Low	
	Raising too slowly — MSB (Item 8.10 in Table B.1A)	8 (1,3)	7 (1,2)	Low	
	Movement in the wrong vertical direction — RHI (Item 8.13 in Table B.1A)	8 (1,3)	8 (1,3)	Low	
	Movement in the wrong horizontal direction — MSB (Item 8.14 in Table B.1A)	8 (1,3)	8 (1,3)	Low	
	Movement in the wrong horizontal direction — RHI (Item 8.15 in Table B.1A)	8 (1,3)	8 (1,3)	Low	

— Not applicable

\* Further review required to reasonably assess any risk reduction potential

Table D.9 Estimated Impact of Recommendations on Related Coarse Hazard Analysis Deviations (cont'd)

Recommendations	Associated Coarse Hazard Analysis Deviations	Initial Risk Index Number	Revised Risk Index Number	Certainty in Revised Risk Index Number	Notes
<i>Recommendation 5 (cont'd)</i>	Excessive sway during lowering/raising — MSB (Item 8.16 in Table B.1A)	14 (2,4)	8 (1,3)	Medium	
	Excessive sway during lowering/raising — RHI (Item 8.17 in Table B.1A)	8 (1,3)	7 (1,2)	Medium	
<i>Recommendation 6 — Consider reformatting vessel operational procedures to a more training-useable format</i>	All small boat deviations (Section 8 in Table B.1A)	--	*	*	Any changes in the risk profile will not be known until further evaluation is completed

-- Not applicable

\* Further review required to reasonably assess any risk reduction potential

Table D.9 Estimated Impact of Recommendations on Related Coarse Hazard Analysis Deviations (cont'd)

Recommendations	Associated Coarse Hazard Analysis Deviations	Initial Risk Index Number	Revised Risk Index Number	Certainty in Revised Risk Index Number	Notes
<i>Recommendation 7 — To reduce the effects of fatigue, the USCG should consider (1) increasing the number of deck division billets onboard larger cutters, or (2) providing definitive guidance outlining reasonable levels-of-effort expected from USCG vessels when fulfilling mission requirements</i>	All small boat deviations (Section 8 in Table B.1A)	--	*	*	Any changes in the risk profile will not be known until further evaluation is completed
<i>Recommendation 8 — Consider adding a precautionary statement to the MSB launch/recovery procedure to warn of the hazards of missing deck plating under the MSB</i>	Loss of support — MSB (Item 8.1 in Table B.1A)	13 (2,3)	13 (2,3)	High	Minor risk reduction could be realized (training benefit) due to reducing human error associated with this change

-- Not applicable

\* Further review required to reasonably assess any risk reduction potential

Table D.9 Estimated Impact of Recommendations on Related Coarse Hazard Analysis Deviations (cont'd)

Recommendations	Associated Coarse Hazard Analysis Deviations	Initial Risk Index Number	Revised Risk Index Number	Certainty in Revised Risk Index Number	Notes
<i>Recommendation 9 — Consider installing a lip on the side of the vessel at the MSB boat deck to ensure that the MSB does not lose its grip while snugged to the hull when loading/unloading the boat crew and passengers</i>	Excessive sway during lowering/raising — MSB (Item 8.16 in Table B.1A)	14 (2,4)	9 (1,4)	Medium	Lip on side of deck should greatly reduce the chances of the MSB slipping free
<i>Recommendation 10 — Consider using a quick release/easy hook-up fastening mechanism for the end of the sea painter line</i>	Small boat fastened to vessel during launching (MSB and RHI) (Item 8.21 in Table B.1A)	8 (1,3)	7 (1,2)	Medium	Mechanism reduces the chance of hands/fingers getting caught in sea painter during release and hook-up
<i>Recommendation 11 — Consider upgrading the MSB recovery procedure to include setting the davit arm pins back in place</i>	Loss of support — MSB (Item 8.1 in Table B.1A)	13 (2,3)	12 (2,2)	Low	Small potential reduction in Class C/D mishaps (MSB damage)

-- Not applicable

\* Further review required to reasonably assess any risk reduction potential

Table D.9 Estimated Impact of Recommendations on Related Coarse Hazard Analysis Deviations (cont'd)

Recommendations	Associated Coarse Hazard Analysis Deviations	Initial Risk Index Number	Revised Risk Index Number	Certainty in Revised Risk Index Number	Notes
<i>Recommendation 12</i> — Consider extending the length of the port bridge wing to allow an increased view of RHI operations	Excessive sway during lowering/raising — RHI (Item 8.17 in Table B.1A)	8 (1,3)	7 (1,2)	Medium	Bridge would be in a better position to see how the deck crew responds to winds/seas and to the effects of the vessel's launch/recovery course/speed
<i>Recommendation 13</i> — Consider adding a step to the RHI launch procedure that directs the boom cable to be hooked to the metal ring attached to the supporting straps	Loss of support — RHI (Item 8.2 in Table B.1A)	8 (1,3)	8 (1,3)	Medium	Minor risk reduction could be realized (training benefit) due to reducing human error associated with this change
<i>Recommendation 14</i> — Consider adding a step to the RHI recovery procedure to ensure that all gear is secured and stored	--	--	--	--	Not applicable to coarse hazard analysis deviations. However, it lowers the chances of losing equipment (mainly safety gear) overboard

-- Not applicable

\* Further review required to reasonably assess any risk reduction potential

**Table D.10 Estimated Impact of Relevant Recommendations on the Risk Index Number of Related Coarse Hazard Analysis Deviations**

Deviation	Coarse Hazard Analysis Recommendation(s)	Initial Risk Index Number	Revised Risk Index Number	Certainty in Revised Risk Index Number	Notes
All small boat deviations (Section 8 in Table B.1A)	<i>Recommendation 1 — Consider documenting the factors (with supporting guidance) used to make go/no-go decisions for launching small boats</i>	--	*	*	Any changes in the risk profile will not be known until further evaluation is completed
	<i>Recommendation 2 — Consider documenting the factors (with supporting guidance) used to select between the MSB and the RHI</i>	--	*	*	
	<i>Recommendation 6 — Consider reformatting vessel operational procedures to a more training-useable format</i>	--	*	*	
	<i>Recommendation 7 — To reduce the effects of fatigue, the USCG should consider (1) increasing the number of deck division billets onboard larger cutters, or (2) providing definitive guidance outlining reasonable levels-of-effort expected from USCG vessels when fulfilling mission requirements</i>	--	*	*	

— Not applicable

\* Further review required to reasonably assess any risk reduction potential



**Table D.10 Estimated Impact of Relevant Recommendations on the Risk Index Number of Related Coarse Hazard Analysis Deviations (cont'd)**

Deviation	Coarse Hazard Analysis Recommendation(s)	Initial Risk Index Number	Revised Risk Index Number	Certainty in Revised Risk Index Number	Notes
Loss of support — MSB (Item 8.1 in Table B.1A)	<i>Recommendation 5 — Consider having deck crews wear cranial protection of a wraparound design instead of hard hats</i>	13 (2,3)	7 (1,2)	Medium	Dominated by Recommendation 5, which has the greatest effect on deviations in which the boat crew could experience a large physical impact
	<i>Recommendation 8 — Consider adding a precautionary statement to the MSB launch/recovery procedure to warn of the hazards of missing deck plating under the MSB</i>				
	<i>Recommendation 11 — Consider upgrading the MSB recovery procedure to include setting the davit arm pins back in place</i>				

-- Not applicable

\* Further review required to reasonably assess any risk reduction potential

Table D.10 Estimated Impact of Relevant Recommendations on the Risk Index Number of Related Coarse Hazard Analysis Deviations (cont'd)

Deviation	Coarse Hazard Analysis Recommendation(s)	Initial Risk Index Number	Revised Risk Index Number	Certainty in Revised Risk Index Number	Notes
Loss of support — RHI (Item 8.2 in Table B.1A)	<i>Recommendation 5 — Consider having deck crews wear cranial protection of a wraparound design instead of hard hats</i>	8 (1,3)	7 (1,2)	Low	Dominated by Recommendation 5, which has the greatest effect on deviations in which the boat crew could experience a large physical impact (not much effect here)
	<i>Recommendation 13 — Consider adding a step to the RHI launch procedure that directs the boom cable to be hooked to the metal ring attached to the supporting straps</i>				
Lowering too quickly — MSB (Item 8.4 in Table B.1A)	<i>Recommendation 5 — Consider having deck crews wear cranial protection of a wraparound design instead of hard hats</i>	8 (1,3)	7 (1,2)	Low	Recommendation 5 has the greatest effect on deviations in which the boat crew could experience a large physical impact (not much effect here)
Lowering too slowly — MSB (Item 8.6 in Table B.1A)	<i>Recommendation 5 — Consider having deck crews wear cranial protection of a wraparound design instead of hard hats</i>	9 (1,4)	8 (1,3)	Low	Recommendation 5 has the greatest effect on deviations in which the boat crew could experience a large physical impact (not much effect here)

-- Not applicable

\* Further review required to reasonably assess any risk reduction potential

**Table D.10 Estimated Impact of Relevant Recommendations on the Risk Index Number of Related Coarse Hazard Analysis Deviations (cont'd)**

Deviation	Coarse Hazard Analysis Recommendation(s)	Initial Risk Index Number	Revised Risk Index Number	Certainty in Revised Risk Index Number	Notes
Raising too quickly — MSB (Item 8.8 in Table B.1A)	<i>Recommendation 5 — Consider having deck crews wear cranial protection of a wraparound design instead of hard hats</i>	8 (1,3)	7 (1,2)	Low	Recommendation 5 has the greatest effect on deviations in which the boat crew could experience a large physical impact (not much effect here)
Raising too quickly — RHI (Item 8.9 in Table B.1A)	<i>Recommendation 5 — Consider having deck crews wear cranial protection of a wraparound design instead of hard hats</i>	8 (1,3)	8 (1,3)	Low	Recommendation 5 has the greatest effect on deviations in which the boat crew could experience a large physical impact (not much effect here)
Raising too slowly — MSB (Item 8.10 in Table B.1A)	<i>Recommendation 5 — Consider having deck crews wear cranial protection of a wraparound design instead of hard hats</i>	8 (1,3)	7 (1,2)	Low	
Movement in the wrong vertical direction — RHI (Item 8.13 in Table B.1A)	<i>Recommendation 5 — Consider having deck crews wear cranial protection of a wraparound design instead of hard hats</i>	8 (1,3)	8 (1,3)	Low	

-- Not applicable  
 \* Further review required to reasonably assess any risk reduction potential

Table D.10 Estimated Impact of Relevant Recommendations on the Risk Index Number of Related Coarse Hazard Analysis Deviations (cont'd)

Deviation	Coarse Hazard Analysis Recommendation(s)	Initial Risk Index Number	Revised Risk Index Number	Certainty in Revised Risk Index Number	Notes
Movement in the wrong horizontal direction — MSB (Item 8.14 in Table B.1A)	<i>Recommendation 4 — Consider adding a visual aid to indicate when the MSB/RHI has been breasted out to the correct position prior to putting it to the rail</i>	8 (1,3)	7 (1,2)	Medium	Dominated by Recommendation 4, which should lower the number of actual movements and provide a defined target for adjusting small boat horizontal positions
	<i>Recommendation 5 — Consider having deck crews wear cranial protection of a wraparound design instead of hard hats</i>				
Movement in the wrong horizontal direction — RHI (Item 8.15 in Table B.1A)	<i>Recommendation 4 — Consider adding a visual aid to indicate when the MSB/RHI has been breasted out to the correct position prior to putting it to the rail</i>	8 (1,3)	7 (1,2)	Medium	Dominated by Recommendation 4, which should lower the number of actual movements and provide a defined target for adjusting small boat horizontal positions
	<i>Recommendation 5 — Consider having deck crews wear cranial protection of a wraparound design instead of hard hats</i>				

-- Not applicable  
 \* Further review required to reasonably assess any risk reduction potential

**Table D.10 Estimated Impact of Relevant Recommendations on the Risk Index Number of Related Coarse Hazard Analysis Deviations**  
(cont'd)

Deviation	Coarse Hazard Analysis Recommendation(s)	Initial Risk Index Number	Revised Risk Index Number	Certainty in Revised Risk Index Number	Notes
Excessive sway during raising/lowering — MSB (Item 8.16 in Table B.1A)	<i>Recommendation 5 — Consider having deck crews wear cranial protection of a wraparound design instead of hard hats</i>	14 (2,4)	8 (1,3)	Medium	Both recommendations carry equal weight
	<i>Recommendation 9 — Consider installing a lip on the side of the vessel at the MSB boat deck to ensure that the MSB does not lose its grip while snugged to the hull when loading/unloading the boat crew and passengers</i>				
Excessive sway during raising/lowering — RHI (Item 8.17 in Table B.1A)	<i>Recommendation 5 — Consider having deck crews wear cranial protection of a wraparound design instead of hard hats</i>	8 (1,3)	7 (1,2)	Medium	Both recommendations carry equal weight
	<i>Recommendation 12 — Consider extending the length of the port bridge wing to allow an increased view of RHI operations</i>				

-- Not applicable  
\* Further review required to reasonably assess any risk reduction potential

Table D.10 Estimated Impact of Relevant Recommendations on the Risk Index Number of Related Coarse Hazard Analysis Deviations (cont'd)

Deviation	Coarse Hazard Analysis Recommendation(s)	Initial Risk Index Number	Revised Risk Index Number	Certainty in Revised Risk Index Number	Notes
Slow speed/power of small boat (alongside vessel) (MSB and RHI) (Item 8.19 in Table B.1A)	<i>Recommendation 3 — Consider enhancing small boat launch precautionary statements to include verification of small boat physical conditions (engineering and deck conditions) prior to launch</i>	8 (1,3)	7 (1,2)	Low	Some risk reduction realized, but the deviation is human-error-dominated
Small boat fastened to vessel during launching (MSB and RHI) (Item 8.21 in Table B.1A)	<i>Recommendation 10 — Consider using a quick release/easy hook-up fastening mechanism for the end of the sea painter line</i>	8 (1,3)	7 (1,2)	Medium	Mechanism reduces the chance of hands/fingers getting caught in sea painter during release and hook-up

-- Not applicable

\* Further review required to reasonably assess any risk reduction potential

To show the financial (savings) impact of implementing recommendations, the coarse hazard analysis calculated the potential dollars savings of implementing each recommendation. Risk index number reductions from each recommendation were individually factored into the overall WMEC-270 coarse hazard analysis risk profile to achieve a numerical risk reduction value. This value was translated into cost savings and shown graphically.

Figure D.5 graphically identifies the overall risk reduction estimated to occur through implementation of each recommendation (based on the assumption that the average Class A/B mishap is equivalent to a \$250,000 loss and the average Class C/D mishap is equivalent to \$50,000 loss). This information clearly highlights the relative benefits of some recommendations over others as well as the level of investment reasonable for each recommendation. For some recommendations, revised risk index numbers are not provided because of the uncertainty of the effects of implementing the recommendations.

#### ***D.8 OBSERVATIONS/CONCLUSIONS FROM THE ANALYSIS***

Small boat operations are among the higher risk functions performed on WMEC-270 class vessels. In spite of its dangers, the USCG has repeatedly demonstrated its capability to conduct such evolutions efficiently and safely. Nevertheless, it was believed that some safety improvement could be realized.

The detailed hazard analysis team used multiple, systematic methods to evaluate small boat launch/recovery evolutions from operations, human error, and procedural format perspectives. These methods allowed complete coverage of small boat issues while analyzing distinct elements in small boat operations. Furthermore, the methods are not unnecessarily complex, nor are the results, and should be understandable to personnel not trained in risk/hazard assessment techniques. The team ultimately developed 14 recommendations for reducing risk, which are presented to the USCG for review and consideration. In addition to the team's recommendations, the team also made the following observations on small boat operations:

- (1) A sea painter line is used for launch and recovery of both small boats. The sea painter provides extra control by placing the small boat in tow when releasing or hooking up hoisting lines. Losing the sea painter during launch or recovery can prolong the evolution (possibly endangering the crew). Having an extra line ready for immediate use (not necessarily right there on the deck) allows the launch/recovery detail to quickly respond and may lower the chances of mishaps.
- (2) Crew members tend to be less vigilant and less concerned about risks when performing small boat operations in less risky situations (lowering small boats in port for drills, maintenance

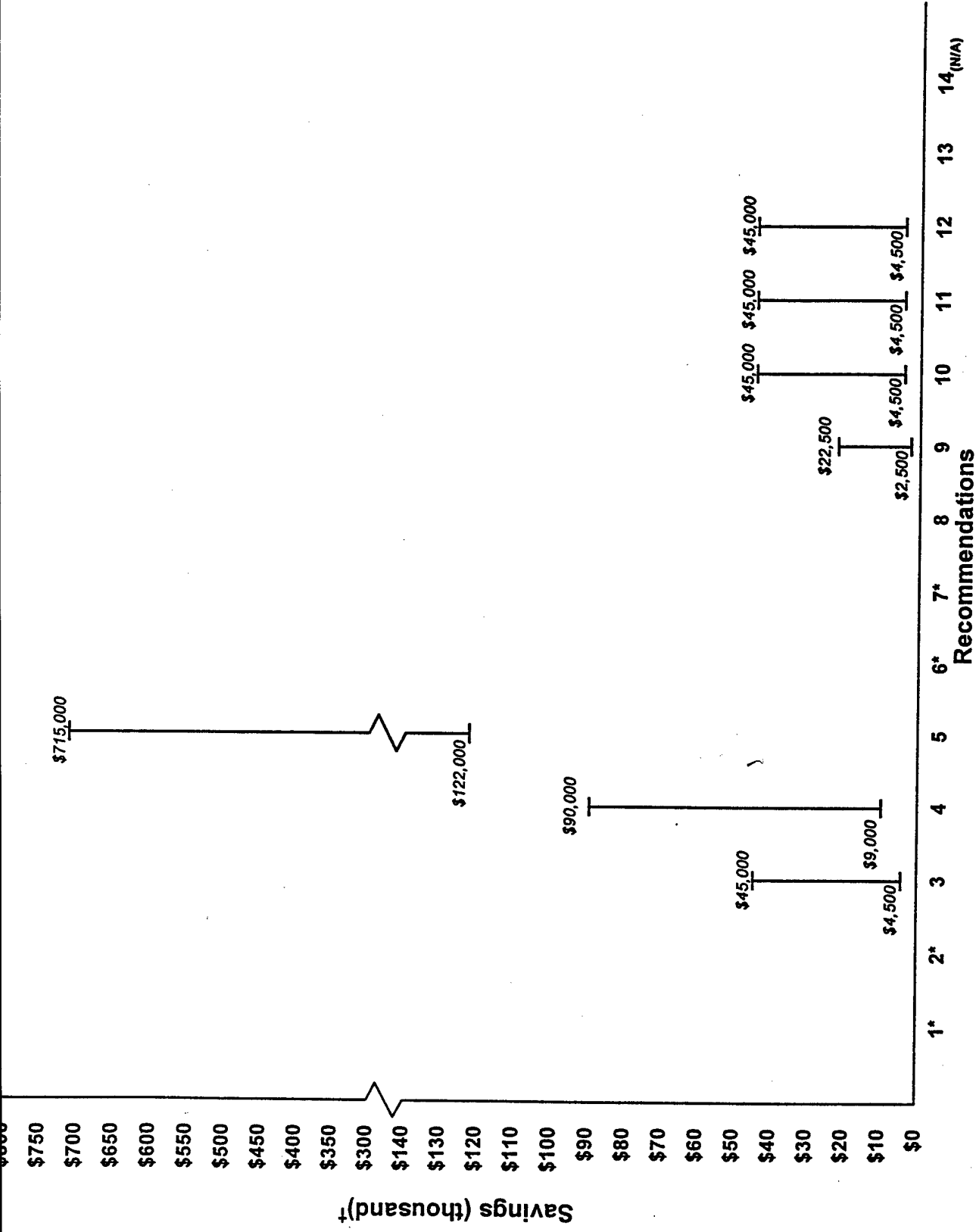

\*A reasonable estimate of savings is only possible after this recommendation is reviewed further.

†Savings estimate assumes Class A/B mishaps cost \$250,000 and Class C/D mishaps cost \$50,000.

Figure D.5 Estimated Range in Dollar Savings Upon Implementing a Small Boat Recommendation for WMEC-270



work, etc.). These situations may be more risky due to a perception of less danger by deck/boat crews. Small boat safety should be stressed for in-port operations.

- (3) When cradling the MSB during recovery, deck personnel must first set the retaining shoes to receive the MSB and then manually guide the MSB into place while it is being lowered into the cradle. In this position, the heavy MSB is cumbersome to maneuver by hand. Any sway placed on the MSB (such as from vessel motion) complicates the situation. Deck personnel can easily suffer an injury if limbs are caught between the MSB and the davit arms. Off-going boat crewman should assist the deck crew in stabilizing and positioning the MSB as it is being cradled.
  
- (4) When preparing to load/unload the MSB and RHI, each small boat is snugged (secured) against the rail to position it for personnel/equipment loading/unloading (Note: the RHI is only partially loaded/unloaded at this point). If it loses its grip at this point, personnel/equipment may be lost overboard and/or personnel may be injured. Although not specifically covered in the WMEC-270 coarse hazard analysis, this deviation is considered part of the coarse hazard analysis deviation "Excessive sway during lowering/raising" for both the MSB and the RHI. The risk characterizations for this deviation (i.e., the risk index numbers calculated for this deviation for MSB and RHI operations) are still considered valid and should not be changed. It may be worthwhile to add this as a separate deviation to future coarse hazard analysis under the title "Inadvertent movement of the small boat while loading/unloading."

The results from this study do not significantly change the findings from the coarse hazard analysis regarding small boat operations. The coarse hazard analysis identified certain aspects of small boat operations, especially a loss of small boat support (physical support) and excessive sway while lowering/raising, as higher risk items. This study confirms those findings. However, the coarse hazard analysis team assigned a low certainty when assessing the loss of support deviation (mainly for MSB operations), whereas they had a high certainty when assessing the excessive sway deviation (applicable to MSB and RHI operations). The only recommended change to the coarse hazard analysis should be to assign a high certainty to the loss of support deviation (for MSB operations).

Overall, it is concluded that the coarse hazard analysis was an accurate first pass assessment of small boat operational risks, especially considering the level of resolution needed at that phase in a hazard/risk assessment. Implementing all of the recommendations should lower these risks. This detailed study provided a more focused review of small boat operators and thus developed recommendations that the coarse hazard analysis would not have produced (nor should have produced due the level of resolution needed from a coarse hazard analysis).

**ATTACHMENT A**

***Motor Surf Boat (MSB) and  
Rigid Hull Inflatable Boat (RHI) Launch/Recovery Procedures  
&  
Engineering and Deck Division Small Boat Checklists***

**DECK STANDING ORDER #1  
RHI LOWERING AND HOISTING PROCEDURES**

1. LOWERING/HOISTING DETAIL SHALL CONSIST OF THE FOLLOWING MINIMUM PERSONNEL:

<u>BILLET</u>	<u>POSITION</u>	<u>STATION</u>
BMC, BM2, BM3	IN CHARGE	BOAT DECK
1LT, BMC, BM2, BM3	SAFETY OBSERVER	FLIGHT DECK
AS DIRECTED	COXSWAIN	BOAT DECK
AS DIRECTED	SEA PAINTER TENDER	FLIGHT DECK
AS DIRECTED	FRAPPING LINE TENDER, FWD	FANTAIL
AS DIRECTED	FRAPPING LINE TENDER, AFT	FANTAIL
AS DIRECTED	ARTICULATING CRANE OPERATOR	CONTROLS
AS DIRECTED	COMMUNICATIONS (VHF)	PROVIDED BY BMOW

2. The procedure for lowering the RHI is as follows:

a. Upon hearing "Make preparations to launch port boat", the lowering detail shall man their stations, and the boat coxswain and engineer shall enter the boat and ungrape it. The lowering detail and boat crew shall don hard hats and life vests. Anti-exposure suits shall be worn if the sea temperature is less than 60 degrees F.

b. Ready reports are received by the POIC as follows:

- (1) Ready on the sea painter
- (2) Ready forward
- (3) Ready aft

c. After the ready reports are received, the POIC relays to the bridge "Manned and ready, request permission to swing out and put the boat to the rail."

d. After receiving permission to put the boat to the rail, the POIC gives the operator hand signals to raise the RHI into the J-hooks, and the crane operator raises the boat into the J-hooks.

e. After the boat is securely in the J-hooks, the POIC gives the crane operator hand signals to swing the RHI outboard the rail port side. While the boat is being rotated, the sea painter tender takes up the slack on the sea painter. Line handlers shall position themselves at the cleats fore and aft of the RHI on fantail and tend all lines as its being swung.

f. The POIC then directs the crane operator to lower the RHI to the rail. While the boat is being lowered, the POIC will ensure the main boom is extended in order to allow the RHI to clear the ship's lifelines and gunwale, placing the boat snug against the hull to keep it from beating against the ship.

g. Once the RHI is at the rail, the POIC requests permission from the bridge to "Lower the boat".

h. After permission is granted to lower the RHI, the POIC orders the crew to lay into the boat. Unless otherwise directed, no more than two people at a time will be lowered in the RHI.

i. The boat crew shall enter the boat and man their appropriate stations, being careful not to step on the gunwale.

j. Once the boat crews gives the "Ready in the boat", the POIC directs the crane operator to lower the boat. The frapping line tenders shall hold medium tension on the frapping lines to prevent the boat from swinging. When the RHI is in the water, the hook is released by the boat engineer and the cable is raised. The coxswain starts the boat.

k. Once the RHI is in the water, the Jacobs ladder is placed over the side and, the POIC orders passengers to lay into the boat. Passengers lay into the boat one at a time using the Jacobs ladder.

l. When all passengers are embarked, the coxswain orders "Cast off the aft frapping line." The after frapping line tender throws his/her frapping line into the after part of the RHI. The coxswain then orders "Cast off the forward frapping line" and the forward frapping line tender throws his/her frapping line into the bow of the RHI.

m. When the coxswain is ready to veer away, he rides out on the sea painter and then orders, "Release the sea painter." When the painter is released, the sea painter tender shall heave around smartly, pulling it from the boat and out of the water. He/She then shall make it ready for passing.

n. During all RHI hoisting procedures the safety observer shall be stationed above the crane on the flight deck. He has communications with the bridge. If any safety violations are observed, he may stop the evolution by his command until the discrepancy is rectified.

## BOAT HOISTING PROCEDURES FOR THE RHI

1. Stations for raising are the same as for lowering.
2. The procedures for raising the boat are as follows:
  - a. Word is passed over the LMC, "Make preparations to receive RHI".
  - b. Boat lowering detail lay to the port boat deck.
  - c. POIC determines all stations are manned and ready.
  - d. When ready, POIC advises the bridge (OOD) "Ready on deck." The coxswain is granted permission to come alongside and receive the sea painter. After the coxswain signals, the sea painter is passed.
  - e. Small boat maneuvers to receive the sea painter, hooks up and maneuvers alongside.
  - f. Tending lines are passed up to the forward and aft line tenders.
  - g. Only two passengers may be in the RHI when it is hoisted up. All other passengers shall debark by means of the Jacobs ladder before the RHI is raised.
  - h. While the boat is being held in place by the tending lines and the sea painter, the POIC orders the passengers to lay out of the boat one at a time. All persons debark except the coxswain and duty engineer. Once all passengers have debarked the POIC directs the crane operator to "Lower the hook". Care must be exercised in heavy seas to ensure that the boat engineer has enough slack to safely hook the RHI.
  - i. Once the RHI is hooked, the coxswain reports "Ready in the boat". At this time the POIC directs the crane operator to "Raise the boat".
  - j. When the RHI is snug against the hull, the POIC orders the boat crew to "lay out of the boat." Once clear, the POIC directs the crane operator to "Raise the boat into the J-hooks." The RHI is guided into the J-hooks.
  - k. Once the RHI is hooked, the POIC directs the crane operator to "Swing around counter clockwise." As the boat is rotated, the sea painter tender lets out enough slack to allow the boat to swing around into the cradle.
    1. Once over the cradle, the POIC directs the crane operator to avast swinging around. He/She then directs the crane operator to lower the RHI slowly while the line tenders guide the boat into the cradle.

iii. Once in the cradle, the POIC directs the unhooking of the RHI from the lifting straps the crane operator to secure the crane cable. The lowering detail gripes down the RHI and reports to the bridge that the RHI is griped down and ready for sea.

DECK STANDING ORDER #2  
MSB LOWERING AND HOISTING PROCEDURES

1. Lowering/hoisting detail shall consist of the following minimum personnel:

<u>BILLET</u>	<u>POSITION</u>	<u>STATION</u>
BMC, BM2, BM3,	IN CHARGE	BOAT DECK
1LT, BMC, BM2, BM3	SAFETY OBSERVER	BOAT DECK
AS DIRECTED	COXSWAIN	BOAT DECK
AS DIRECTED	CREWMAN	BOAT DECK
AS DIRECTED	SEA PAINTER TENDER	FORECASTLE
AS DIRECTED	FRAPPING LINE TENDER, FWD	FORWARD DAVIT
AS DIRECTED	FRAPPING LINE TENDER, AFT	AFT DAVIT
AS DIRECTED	WINCH OPERATOR	CONTROLS
AS DIRECTED	COMMUNICATIONS (VHF)	PROVIDED BY BMOW

2. The procedure for lowering the MSB is as follows:

a. Upon hearing "MAKE PREPARATIONS FOR LOWERING THE STARBOARD SMALL BOAT", the lowering detail and boat crew shall muster aft of the MSB. The lowering detail and boat crew shall don hard hats and life vests. Anti-exposure suits shall be worn if the sea temperature is less than 60 Degrees F.

b. All hands shall then man their stations. The boat crew shall lay to the loading platform after permission is received from the OOD.

c. Frapping line tenders shall assist the boat crew in ungriping the boat, releasing the preventers and lowering lifelines. Note: Any personnel entering the boat shall receive permission to do so from the Officer/Petty Officer in charge, who shall receive permission from the OOD.

d. After the completion of their initial tasks, they shall lay out of the boat and standby.

e. Ready reports are received by the Officer/Petty Officer in charge as follows:

(1) "Ready on the sea Painter"

(2) "Ready forward"

(3) "Ready aft"

(4) "Ready on the boat lowering platform"

f. After the ready reports are received, the POIC relays to the bridge, "Manned and ready, request permission to "Put the boat to the rail."

g. After receiving permission, the POIC will then give the following orders:

(1) "Stand by your lines."

(2) The POIC raises the MSB approx. 6" and orders "Release shoes." The forward and aft frapping line tenders shall drop the outboard shoes and advise the POIC "Fore shoe released," "Aft shoe released."

(3) The POIC will then order "Remove pins." The forward and aft frapping line tenders shall remove the retaining pins for the davit and advise the POIC "Fore pin removed," "Aft pin removed."

h. The POIC shall breast the boat outboard.

i. The frapping line tenders shall hold medium tension on the frapping line as the boat moves outboard. Care shall be taken to prevent the boat from swinging excessively.

j. The POIC shall bring the boat to the rail and snug it in against the hull.

k. After the boat is to the rail, the POIC requests permission to "Man the boat."

l. After receiving permission, the POIC orders the crew to lay into the boat. Unless otherwise directed, no more than seven people at a time will be lowered in the MSB.

m. The boat crew shall enter the boat and man their appropriate station. Avoid stepping on the gunwale when entering the boat.

n. The appropriate number of monkey lines shall be dropped over the outboard side of the MSB. Each boat crewman will hold on to the man ropes so that 80% of their weight is supported on the man rope.

o. When all is ready in the boat, the coxswain shall inform the POIC, "Ready in the boat"

p. After receiving the ready from the coxswain, the POIC requests permission to "Lower the boat".

q. After receiving permission, the POIC shall give directions to the MSB davit operator via hand signals to swing the MSB clear of the hull and whip down on the falls at speeds appropriate for the sea conditions. The falls shall be whipped down until the fall tensioner arms come all the way down. This will provide enough slack in the fall for the crewmen to attach the release gear to the MSB without taking tension or bird nest the cable on the drum.

r. When waterborne, the boat crew shall place the monkey lines on the inboard side of the boat being careful not to tangle them. The coxswain shall start the boat.



t. The coxswain orders "Release aft" and awaits the reply, "Released aft"; orders "Release forward" and awaits the reply, "Released forward."

u. When the falls are released, the boat crewmen should hold onto until the blocks until the frapping line tenders can pull them away from the MSB and into the side of the ship.

v. The coxswain shall maneuver the MSB away from the ship, riding the sea painter until he orders it released.

w. Once released, the sea painter tender shall heave around smartly, pulling the sea painter from the boat and out of the water.

x. The sea painter tender shall make the painter ready for passing.

## BOAT HOISTING PROCEDURES FOR THE MSB

1. Stations for raising are the same as for lowering.
2. The procedure for raising the boat is as follows:
  - a. Word is passed over IMC, "Deck force make preparations to receive small boat starboard side."
  - b. All hands man their stations.
  - c. POIC determines all stations are manned and ready as per #4 in lowering procedures and that enough slack is in the falls to ensure rapid recovery of the boat.
  - d. When ready, POIC advises bridge (OOD) "Ready on deck, request permission to receive small boat". Coxswain is granted permission to come alongside and receive sea painter. After the coxswain signals, the sea painter is passed.
  - e. Small boat maneuvers to receive the sea painter, hooks up and maneuvers alongside.
  - f. Appropriate number of monkey lines are cast loose and placed on the outboard side of small boat. The davit can only support 7000lbs of dynamic weight. So consideration must be made for the amount of weight of the MSB prior to putting people or cargo into it. (Example: If MSB weighs 5600 lbs then the maximum weight you could load is 1400 lbs. That's only 7 persons at 180 lbs each.)
  - g. Frapping lines are slacked, falls are grabbed by bow and stern hooks, coxswain is advised "Ready forward" and "Ready aft".
  - h. Upon receiving the ready forward and aft, the coxswain orders "Hook forward" to the bow hook, and is advised "Hooked forward" by the bow hook; the coxswain orders "Hook aft", and is advised "Hooked aft" by the stern hook. The coxswain then stops the engine.
  - i. Coxswain advises POIC "Ready in the boat".
  - j. The POIC raises the boat to the rail. Care must be taken so as to not jerk the MSB from the water (if the sea conditions permit) and not until the MSB is directly under the falls.
  - k. When the boat is set, the POIC orders "Boat crew lay out of the boat".
  - l. After the boat is clear, the POIC requests permission to "Cradle the boat".
  - m. Once the affirmative is given, the POIC raises the boat to the upper limit. He/She then breasts the boat in during which he/she orders frapping line tenders to "Check shoes". Frapping line tenders ensure shoes are in the down position and report same to POIC.

When shoes are in the up position, frapping line tenders advise the POIC by stating "Forward shoe set" and "After shoe set".

o. POIC lowers boat manually and while doing so orders frapping line tenders to "Guide in". Frapping line tenders guide the boat into the cradle and advise POIC when the bow, center and stern are set in the cradle.

p. When the boat is set, POIC gripes down the boat; he then ensures all gear is secured and stowed.

3. In the event of power failure or winch/pump casualty:

a. A minimum of two people are required to operate the manual ram pump.

b. A minimum of two people are required to manually hoist the boat.

25FT MSB  
MORNING CHECK OFF SHEET

THE MORNING CHECKOFF SHEET SHALL BE COMPLETED AND SIGNED EACH MORNING PRIOR TO 0800. THIS COPY IS TO BE GIVEN TO THE BMC. ANY DISCREPANCIES ARE TO BE CORRECTED. ANY DISCREPANCY THAT IS UNABLE TO BE CORRECTED SHALL BE RECORDED IN THE BOTTOM SECTION AND BROUGHT TO THE ATTENTION OF THE BMC.

EQUIPMENT ON MSB	QTY	CHECK
BOAT FENDERS	4	_____
ANCHOR (DANFORTH)	1	_____
ANCHOR LINE/TOWLINE 2" 100 FT	1	_____
BOAT HOOK 6 FT	2	_____
FIRE EXTINGUISHER	1	_____
LIFE RING AND LIGHT XX"	2	_____
SEARCHLIGHT	1	_____
FID/SEA PAINTER	1	_____
FLASHLIGHT	1	_____
NATIONAL ENSIGN	1	_____
CG ENSIGN	1	_____
LIFE PRESERVERS TYPE I	5	_____
MEGAPHONE HAND	1	_____
UTILITY PAIL	1	_____
BOAT OPERATING INSTRUCTIONS	1	_____
EMERGENCY TILLER	1	_____
RECALL & LIFEBOAT SIGNALS	1	_____
RESCUE HEAVING BALLS	2	_____
60 FT EXTRA LINE	1	_____

EQUIPMENT IN RESCUE BOAT BOX

FIRST AID KIT	1	_____
HORN (REED)	1	_____
BLANKET	2	_____
SEMAPHORE FLAGS	2 (SETS)	_____
BATTLE LANTERNS	2	_____
GRAPPLING HOOKS WITH 100 FT LINE EACH	2	_____
HATCHET	1	_____
SHEARS 12" CANVAS CUTTING	1	_____
V-BLADE RESCUE KNIFE	1	_____
FIRE EXTINGUISHER	1	_____
*SWIMMER TENDING LINE 300 YDS	1	_____
*RESCUE LITTER	1	_____

DATE \_\_\_\_\_ COMPLETED BY \_\_\_\_\_

RIGID HULL INFLATABLE BOAT

THE MORNING CHECKOFF SHEET SHALL BE COMPLETED AND SIGNED EACH MORNING PRIOR TO 0800. THIS COPY IS TO BE GIVEN TO THE BMC. ANY DISCREPANCIES ARE TO BE CORRECTED. ANY DISCREPANCY THAT IS UNABLE TO BE CORRECTED SHALL BE RECORDED IN THE BOTTOM SECTION AND BROUGHT TO THE ATTENTION OF THE BMC.

EQUIPMENT ON RHI	QTY	CHECK
ANCHOR (DANFORTH)	1	_____
ANCHOR LINE/TOWLINE 100 FT 1 1/8"	1	_____
BOAT HOOK 6 FT	1	_____
FIRE EXTINGUISHER 5 LB	1	_____
BILGE PUMP	1	_____
HATCHET	1	_____
LIFE RING AND STROBE LIGHT	1	_____
FIRST AID KIT	1	_____
HORN (MANUAL)	1	_____
RADAR REFLECTOR	1	_____
BOAT PADDLE	1	_____
SEARCHLIGHT	2	_____
SEA PAINTER QUICK DISCONNECT	1	_____
SEA PAINTER 1 1/4"	1	_____
LIFTING SLING	1	_____
FLASHLIGHT	1	_____
NATIONAL/ENSIGN FLAGS	1	_____
LIFEJACKET LOCKER		
BOAT COVER	1	_____
AIR PUMP (BELLOWS)	1	_____
SAR VESTS	4	_____

DATE \_\_\_\_\_ COMPLETED BY \_\_\_\_\_

DATE: \_\_\_\_\_

## SB CHECKS

## I. LIQUID LEVELS

- A. \_\_\_\_\_ OIL  
 B. \_\_\_\_\_ WATER  
 C. \_\_\_\_\_ FUEL  
 D. \_\_\_\_\_ BATTERY  
 E. \_\_\_\_\_ REDUCTION GEAR

## II. ELECTRICAL

- A. \_\_\_\_\_ HOT START  
 B. \_\_\_\_\_ STERN LIGHT  
 C. \_\_\_\_\_ SIDE LIGHTS  
 D. \_\_\_\_\_ INSTRUMENT LIGHTS  
 E. \_\_\_\_\_ HORN

## III. PRE START CHECKS

- A. \_\_\_\_\_ SEA SUCTION OPEN  
 B. \_\_\_\_\_ R/W PUMP DISENGAGED  
 C. \_\_\_\_\_ BILGE & VOIDS  
 D. \_\_\_\_\_ THROTTLE AHEAD  
 E. \_\_\_\_\_ THROTTLE ASTERN  
 F. \_\_\_\_\_ BELTS

## IV. START UP

- A. \_\_\_\_\_ BATTERY SWITCH ON  
 B. \_\_\_\_\_ ALARMS ON  
 C. \_\_\_\_\_ START  
 D. \_\_\_\_\_ OIL PRESSURE  
 E. \_\_\_\_\_ AMPS + OR -  
 F. \_\_\_\_\_ RED GEAR PRESSURE  
 G. \_\_\_\_\_ WATER TEMPERATURE  
 H. \_\_\_\_\_ CLUTCH AHEAD/ASTERN  
 I. \_\_\_\_\_ ENGINE HOURS

- AFTER STARTING ENGINE: RUN FOR FIVE MINUTES AND CHECK FOR LOOSE PARTS, LEAKS, NOISE, AND VIBRATION.  
 • TAKE OIL SAMPLE FOR FALLING BALL TEST \_\_\_\_\_ SSU.  
 • SECURE ENGINE AND EXERCISE STEERING HARD OVER IN BOTH DIRECTIONS.  
 • SECURE FOR SEA AND REPORT ANY DISCREPANCIES TO EOW AND AUX SUPERVISOR.

## WHIB CHECKS

1. \_\_\_\_\_ RUNNING LIGHTS  
 2. \_\_\_\_\_ STEERING  
 3. \_\_\_\_\_ GAS (APPROX GAL)  
 4. \_\_\_\_\_ CABLES  
 5. \_\_\_\_\_ PUT ON FLUSHING ATTACHMENT AND START WATER  
 6. \_\_\_\_\_ START ENGINES AND LET RUN FOR FIVE MINUTES  
 7. \_\_\_\_\_ PLACE ENGINES IN GEAR WHILE RUNNING AT IDLE TO CHECK GEARS

NOTE: PLACING THE ENGINES IN GEAR WHILE SECURED, MAY CAUSE DAMAGE TO THE LOWER UNITS.

- NOTIFY EOW AND OOD WHEN BOAT CHECKS ARE COMPLETED  
 - LIST ANY DISCREPANCIES ON THE BACK OF THIS FORM, AND PLACE IN MACHINERY LOG  
 - LOG ANY FUEL/OIL EXPENDED IN THE SMALL BOAT FUEL LOG LOCATED IN THE AUX SHOP

TOTAL GALLONS OF GASOLINE REMAINING ON BOARD: \_\_\_\_\_

BOAT CHECKS COMPLETED BY: \_\_\_\_\_

OOD: \_\_\_\_\_ EOW: \_\_\_\_\_

( )

REV: 07/04/94

***ATTACHMENT B***

***Motor Surf Boat (MSB) WISE Worksheets***

The proceedings of the WISE review were recorded in Table D.1B using computer software specially designed for this purpose. The table is composed of six columns: **Item Number**, **Deviation**, **Causes**, **Consequences**, **Safeguards**, and **Recommendations**. Table D.1B is similar to that used in the preliminary hazard analysis (coarse hazard analysis) task (SOW Task 4.3.a).

The first column, **Item Number**, represents a distinct action item step in the launch/recovery evolution. The launch/recovery procedure was broken down into distinct steps so that each step could be evaluated in detail.

The second column, **Deviation**, is defined as an upset from normal operations. The WISE technique uses a set of guide words to facilitate evaluation of potential upset conditions/situations. Table D.7 lists the guide words along with descriptions of their meanings. Although the guide words were developed for application within the petroleum and chemical processing industries, they are still applicable to USCG operations.

**Causes** of each deviation are listed in the third column of the worksheet. Generally, only functional failures, human errors, single equipment failures, or external conditions (winds, seas) were considered because these typically are the most significant causes of deviations.

The **Consequences** column identifies the mishaps of interest associated with a particular deviation. Mishaps of interest were identified in the coarse hazard analysis project. The mishap titles are similar to those found in the MISREP database. Table D.2B lists mishaps of interest for this study. If the team found no applicable mishaps or no mishaps at all stemming from a deviation, "No consequences of Interest" was entered into the table. The one exception was in the "Missing" deviation, in which "No missing steps identified" was entered.

**Safeguards** (column 5) are equipment features, procedural steps, or operator actions intended to (1) reduce the likelihood of one or more causes producing consequences or (2) reduce the severity of the given consequences. Training safeguards were listed if crew members are specifically trained on a preventive/protective action. Also, certain safeguards applicable to a wide range of steps, such as the Safety Supervisor monitoring the evolution, were included to show the safeguard's area of coverage.

The last column in the worksheet, **Recommendations**, refers to specific suggestions that are described as recommendations in the report. The suggestions were developed based on analysis team discussions and include hardware additions, procedural upgrades, documentation reviews, and policy/guidance changes. These recommendations are strictly the suggestions of the analysis team. Past USCG studies may already address the identified risks. There may also exist more effective ways for protecting against hazards, and some recommendations may not be practical or cost effective.



Fatigue and external weather exposure issues were considered applicable to most steps in the launch/recovery procedure and were not specifically evaluated in each Item Number step. Table D.3B and Table D.4B list general causes and safeguards for fatigue and exposure respectively.

Table D.1B MSB WISE Worksheets

Item Number	Deviation	Causes	Consequences	Safeguards	Recommendations
<b>1.0 STEP - PERFORM SMALL BOAT CHECKS BEFORE OPERATIONS</b>					
1.1	Missing		No missing steps identified		
1.2	Skip	<p>Engineering or operations fails to perform required checks of liquid levels, electrical systems, engine/throttles status, boat equipment, and rescue box equipment</p> <p>Engineering or operations requirements for checking small boats temporarily suspended because personnel directed to other tasks</p>	<p>Potential for defective or removed safety features aboard the MSB to be unavailable when needed</p> <p>MSB runs out of fuel</p>	<p>OOD verifies that required engineering checks are performed by receiving/reviewing daily engineering small boat check sheet</p> <p>Deck Division LPO verifies that required deck-related small boat checks are performed by receiving/reviewing daily deck small boat checks</p>	3
1.3	Part of		Same as Skip		
1.4	Less		Same as Skip		
1.5	More		No consequences of interest		
1.6	Out of sequence		No consequences of interest		
1.7	As well as		No consequences of interest		
1.8	Other than/reverse		Same as Skip		
1.9	Caught in/on/by/ between		No consequences of interest		

Table D.1B MSB WISE Worksheets (continued)

Item Number	Deviation	Causes	Consequences	Safeguards	Recommendations
1.0 STEP - PERFORM SMALL BOAT CHECKS BEFORE OPERATIONS (continued)					
1.10	Struck by/contact by		No consequences of interest		
1.11	Contact with/struck against		No consequences of interest		
1.12	Slip/trip/fall	Personnel fall from the MSB or the ladder leading to the MSB, especially in wet/icy weather and/or heavy winds/seas	Hazardous exposure: contact injury	Deicing agents and ice removal practices	
1.13	Stress/strain/fatigue		See general personnel fatigue issues		
1.14	Exposure to		See general personnel exposure issues		
1.15	Process upset/malfunction		No consequences of interest		
1.16	Layout/traffic/siting		No consequences of interest		
1.17	Tools/equipment		No consequences of interest		

Table D.1B MSB WISE Worksheets (continued)

Item Number	Deviation	Causes	Consequences	Safeguards	Recommendations
2.0 STEP - DECIDE TO LAUNCH A SMALL BOAT					
2.1	Missing		No missing steps identified		
2.2	Skip	Operations initiates small boat launch without appropriate approval (or misunderstands direction/delegation of authority) from the commanding officer or the executive officer	Potential for a small boat mishap that could result in equipment damage/loss (MSB) and/or a person overboard or hazardous exposure; contact injury (due to fall overboard) if operations fails to detect that conditions are (or could be) unsafe for MSB launching/recovering	Chain of command authority Involvement of multiple people on the bridge and the deck makes failure to obtain appropriate approvals very unlikely	1
2.3	Part of	Operations initiates small boat launch without appropriate evolution-related inputs from bridge and deck personnel	Potential for a small boat mishap that could result in equipment damage/loss (MSB) and/or a person overboard or hazardous exposure; contact injury (due to fall overboard) if operations fails to detect that conditions are unsafe for MSB launching/recovering	Chain of command authority Involvement of multiple people on the bridge and deck makes failure to obtain appropriate evolution-related inputs very unlikely	
2.4	Less		Same as Part of		
2.5	More		No consequences of interest		
2.6	Out of sequence		No consequences of interest		
2.7	As well as		No consequences of interest		

Table D.18 MSB WISE Worksheets (continued)

Item Number	Deviation	Causes	Consequences	Safeguards	Recommendations
2.0 STEP - DECIDE TO LAUNCH A SMALL BOAT (continued)					
2.8	Other than/reverse (wrong decision)	<p>Available weather/sea data is unreliable</p> <p>Crew fails to appropriately assess the significance of available weather/sea data</p> <p>Available vessel/crew status reports are unreliable</p> <p>Crew fails to appropriately assess the significance of available vessel/crew status reports</p>	<p>Potential for a small boat mishap that could result in equipment damage/loss (MSB) and/or a person overboard or hazardous exposure: contact injury (due to fall overboard) if operations fails to detect that conditions are unsafe for MSB launching/recovering</p>	<p>Involvement of multiple people on the bridge and the deck makes failure to appropriately assess situation unlikely (unless the situation is very dynamic and the need to launch is urgent)</p>	1
2.9	Caught in/on/by/between	<p>Crew excessively weights urgency of mission in comparison with other decision factors</p>	No consequences of interest		
2.10	Struck by/contact by	<p>Crew fails to consider how quickly weather, sea, vessel, or crew conditions may change</p>	No consequences of interest		
2.11	Contact with/struck against		No consequences of interest		
2.12	Slip/trip/fall		No consequences of interest		
2.13	Stress/strain/fatigue		See general personnel fatigue issues		

Table D.1B MSB WISE Worksheets (continued)

Item Number	Deviation	Causes	Consequences	Safeguards	Recommendations
<b>2.0 STEP - DECIDE TO LAUNCH A SMALL BOAT (continued)</b>					
2.14	Exposure to		No consequences of interest		
2.15	Process upset/ malfunction		No consequences of interest		
2.16	Layout/traffic/siting		No consequences of interest		
2.17	Tools/equipment		No consequences of interest		
<b>3.0 STEP - DECIDE TO USE THE MSB INSTEAD OF THE RHI</b>					
3.1	Missing		No missing steps identified		
3.2	Skip (launch without appropriate approval)	Operations initiates MSB launch without appropriate approval (or misunderstands direction/delegation of authority) from the commanding officer or the executive officer	Potential for a small boat mishap that could result in equipment damage/loss (MSB) and/or a person overboard or hazardous exposure: contact injury (due to fall overboard) if operations fails to detect that conditions are (or could be) unsafe for the MSB	Chain of command authority Involvement of multiple people on the bridge and the deck makes failure to select appropriate small boat unlikely	2
3.3	Part of		No consequences of interest		
3.4	Less		No consequences of interest		
3.5	More		No consequences of interest		

Table D.1B MSB WISE Worksheets (continued)

Item Number	Deviation	Causes	Consequences	Safeguards	Recommendations
3.0 STEP - DECIDE TO USE THE MSB INSTEAD OF THE RHI (continued)					
3.6	Out of sequence		Same as Skip in the Decide to Launch a Small Boat step (Item 2.2)		
3.7	As well as		No consequences of interest		
3.8	Other than/reverse (wrong decision on which small boat to use)	Operations fails to adequately assess mission conditions and sends MSB instead of RHI (MSB not as fast/as maneuverable as RHI and cannot get to target or get clear of dangerous situation as fast as RHI)	Potential for a small boat mishap that could result in equipment damage/loss (MSB) and/or a person overboard or hazardous exposure: contact injury (due to fall overboard) if operations fails to detect that conditions are (or could be) unsafe for the MSB	Involvement of multiple people on the bridge and the deck makes failure to appropriately assess situation unlikely (unless the situation is very dynamic and the need to launch is urgent)	2
3.9	Caught in/on/by/ between		No consequences of interest		
3.10	Struck by/contact by		No consequences of interest		
3.11	Contact with/struck against		No consequences of interest		
3.12	Slip/trip/fall		No consequences of interest		
3.13	Stress/strain/fatigue		See general personnel fatigue issues		
3.14	Exposure to		No consequences of interest		
3.15	Process upset/malfunction		No consequences of interest		

Table D.1B MSB WISE Worksheets (continued)

Item Number	Deviation	Causes	Consequences	Safeguards	Recommendations
<b>3.0 STEP - DECIDE TO USE THE MSB INSTEAD OF THE RHI (continued)</b>					
3.16	Layout/traffic/siting		No consequences of interest		
3.17	Tools/equipment		No consequences of interest		
<b>4.0 STEP - MAN THE MSB LAUNCH STATIONS</b>					
4.1	Missing		No missing steps identified		
4.2	Skip		No consequences of interest		
4.3	Part of	Required personnel involved in other duties Required personnel not on-board Not all required personnel heard the JMC (intercom) announcement	Potential for a small boat mishap that could result in equipment damage/loss (MSB) and/or a person overboard or hazardous exposure; contact injury (due to fall overboard) if not all deck evolution personnel (safety and operators) are present	Multiple people involved in the deck evolution who can notice that not all required personnel are present  Deck supervisor required to report Manned and Ready to the bridge when all required personnel are present	Other crew members available to support the evolution when needed
4.4	Less		Same as Part of		
4.5	More		No consequences of interest		
4.6	Out of sequence		No consequences of interest		



Table D.18 MSB WISE Worksheets (continued)

Item Number	Deviation	Causes	Consequences	Safeguards	Recommendations
4.0 STEP - MAN THE MSB LAUNCH STATIONS (continued)					
4.7	As well as		No consequences of interest		
4.8	Other than/reverse (wrong or unqualified personnel)	Wrong or unqualified personnel inadvertently called in to fill key small boat launch positions New personnel mistakenly show up for the evolution	Potential for a small boat mishap that could result in equipment damage/loss (MSB) and/or a person overboard or hazardous exposure: contact injury (due to fall overboard) if wrong/unqualified personnel present in key positions	Deck and Safety supervisors check that appropriate personnel are in place All deck personnel advised to speak up if they notice potential safety hazards	
4.9	Caught in/on/by/between		No consequences of interest		
4.10	Struck by/contact by		No consequences of interest		
4.11	Contact with/struck against		No consequences of interest		
4.12	Slip/trip/fall	Deck personnel slip or fall when manning their stations, especially in wet/icy conditions and/or in heavy winds/seas	Hazardous exposure - contact injury Person overboard Equipment damage/loss (lose equipment overboard)	Deicing agents and ice removal practices New personnel are supervised by experienced personnel and by supervisors (actions are observed, new personnel told not to rush, etc.)	
4.13	Stress/strain/fatigue		See general personnel fatigue issues		
4.14	Exposure to		See general personnel exposure issues		

Table D.1B MSB WISE Worksheets (continued)

Item Number	Deviation	Causes	Consequences	Safeguards	Recommendations
<b>4.0 STEP - MAN THE MSB LAUNCH STATIONS (continued)</b>					
4.15	Process upset/ malfunction		No consequences of interest		
4.16	Layout/traffic/siting		No consequences of interest		
4.17	Tools/equipment		No consequences of interest		
<b>5.0 STEP - UNGRIPE THE MSB</b>					
5.1	Missing		No missing steps identified		
5.2	Skip	Deck crew distracted and does not ungrripe MSB	Equipment damage/loss - damage boom hydraulics when moving MSB outboard Equipment damage/loss - damage gripping equipment when moving MSB outboard Hazardous exposure - contact injury: gripping straps snap when moving MSB outboard	Involvement of multiple people on the deck makes failure to ungrripe small boat unlikely	
5.3	Part of		Same as Skip		
5.4	Less		Same as Skip		
5.5	More		No consequences of interest		
5.6	Out of sequence		No consequences of interest		

Table D.1B MSB WISE Worksheets (continued)

Item Number	Deviation	Causes	Consequences	Safeguards	Recommendations
5.0 STEP - UNGRIPE THE MSB (continued)					
5.7	As well as	No consequences of interest			
5.8	Other than/reverse	Same as Skip			
5.9	Caught in/on/by/ between	No consequences of interest			
5.10	Struck by/contact by	Deck supervisor struck by gripping hook as it is released under the MSB	Hazardous exposure - contact injury	New personnel supervised by experienced personnel alongside them Safety supervisor observing small boat evolution	8
5.11	Contact with/struck against	No consequences of interest			
5.12	Slip/trip/fall	Personnel fall from the MSB or the ladder leading to the MSB, especially in wet/icy weather and/or heavy winds/seas	Person overboard Hazardous exposure - contact injury	Safety supervisor monitors evolution New personnel are supervised by experienced personnel and by supervisors (actions are observed, new personnel told not to rush, etc.)	
5.13	Stress/strain/fatigue	See general personnel fatigue issues			
5.14	Exposure to	See general personnel exposure issues			
5.15	Process upset/ malfunction	No consequences of interest			
5.16	Layout/traffic/siting	No consequences of interest			

Table D.1B MSB WISE Worksheets (continued)

Item Number	Deviation	Causes	Consequences	Safeguards	Recommendations
5.0 STEP - UNGRIPE THE MSB (continued)					
5.17	Tools/equipment		No consequences of interest		
6.0 STEP - RELEASE THE SHOES					
6.1	Missing		No missing steps identified		
6.2	Skip	Deck crew distracted and does not release both shoes	Equipment damage/loss: damage to MSB cradle shoes when moving MSB outboard Equipment damage/loss: damage to MSB when moving it outboard	Involvement of multiple people on the deck makes failure to release both shoes unlikely	
6.3	Part of (only one shoe released)	Deck crew distracted and releases only one shoe	Equipment damage/loss: damage to either MSB cradle shoes when moving MSB outboard Equipment damage/loss: damage to MSB when moving outboard	Involvement of multiple people on the deck makes failure to release one shoe unlikely	
6.4	Less		Struck by/contact by (Item 6.10)		
6.5	More		Same as Part of		
6.6	Out of sequence		No consequences of interest		
6.7	As well as		No consequences of interest		

Table D.1B MSB WISE Worksheets (continued)

Item Number	Deviation	Causes	Consequences	Safeguards	Recommendations
6.0 STEP - RELEASE THE SHOES (continued)					
6.8	Other than/reverse	Same as Skip			
6.9	Caught in/on/by/ between	No consequences of interest			
6.10	Struck by/contact by	Part of (only one shoe released) (Item 6.3)	Hazardous exposure - contact injury: personnel injury due to MSB swinging out from released shoe	Involvement of multiple people on deck makes failure to release one shoe unlikely	
6.11	Contact with/struck against	No consequences of interest			
6.12	Slip/trip/fall	No consequences of interest			
6.13	Stress/strain/fatigue	See general personnel fatigue issues			
6.14	Exposure to	See general personnel exposure issues			
6.15	Process upset/ malfunction	No consequences of interest			
6.16	Layout/traffic/siting	No consequences of interest			
6.17	Tools/equipment	No consequences of interest			

Table D.1B MSB WISE Worksheets (continued)

Item Number	Deviation	Causes	Consequences	Safeguards	Recommendations
<b>7.0 STEP - REMOVE THE PINS</b>					
7.1	Missing	No missing steps identified			
7.2	Skip	Deck supervisor distracted and does not issue order to release pins and this goes unnoticed	Equipment damage/loss: damage to MSB davit hydraulics when moving MSB outboard	Involvement of multiple people on the deck makes failure to release both pins unlikely	
7.3	Part of (only one pin released)	Deck crew does not release MSB pins and this goes unnoticed	Equipment damage/loss: damage to MSB pins when moving MSB outboard	Involvement of multiple people on the deck makes failure to release one pin unlikely	
7.4	Less	Deck supervisor distracted and does not issue order to release both pins and this goes unnoticed	Equipment damage/loss: damage to MSB davit hydraulics when moving MSB outboard		
7.5	More	Deck crew does not release forward or after pin and this goes unnoticed	Equipment damage/loss: damage to either forward or after pin when moving MSB outboard		
7.6	Out of sequence	Same as Part of	No consequences of interest		
7.7	As well as	No consequences of interest	No consequences of interest		
7.8	Other than/reverse	No consequences of interest	No consequences of interest		
7.9	Caught in/on/by/between	No consequences of interest	No consequences of interest		

Table D.18 MSB WISE Worksheets (continued)

Item Number	Deviation	Causes	Consequences	Safeguards	Recommendations
7.0 STEP - REMOVE THE PINS (continued)					
7.10	Struck by/contact by		No consequences of interest		
7.11	Contact with/struck against		No consequences of interest		
7.12	Slip/trip/fall		No consequences of interest		
7.13	Stress/strain/fatigue		See general personnel fatigue issues		
7.14	Exposure to		See general personnel exposure issues		
7.15	Process upset/malfunction		No consequences of interest		
7.16	Layout/traffic/siting		No consequences of interest		
7.17	Tools/equipment		No consequences of interest		

Table D.1B MSB WISE Worksheets (continued)

Item Number	Deviation	Causes	Consequences	Safeguards	Recommendations
8.0 STEP - MOVE THE MSB OUTBOARD					
8.1	Missing	No missing steps identified			
8.2	Skip	No consequences of interest			
8.3	Part of	Same as Less			
8.4	Less (MSB not moved out enough)	Deck supervisor misjudges distance MSB moved out	Equipment damage/loss: MSB damaged when lowered onto deck		Involvement of multiple people on the deck makes it unlikely to lower MSB onto deck due to not being out far enough
8.5	More (move MSB too fast)	Deck supervisor orders MSB moved out at too much speed Hydraulic controls operator accidentally moves MSB out too fast	Struck by/contact by (Item 8.10)		
8.6	Out of sequence				Same as Skip in the steps Ungripe the MSB (Item 5.2), Release the Shoes (Item 6.2), and Remove the Pins (Item 7.2)
8.7	As well as				No consequences of interest
8.8	Other than/reverse (no control of MSB sway)	Frapping line tenders do not control sway of MSB - Same as Items 9.4 (Less) and 9.5 (More) in the Tend the MSB Frapping Lines step	Struck by/contact by (Item 8.10)		
8.9	Caught in/on/by/between				No consequences of interest



Table D.1B MSB WISE Worksheets (continued)

Item Number	Deviation	Causes	Consequences	Safeguards	Recommendations
8.0 STEP - MOVE THE MSB OUTBOARD (continued)					
8.10	Struck by/contact by	<p>More (too fast) (Item 8.5)</p> <p>Process upset/malfunction (equipment failure) (Item 8.15)</p> <p>Other than/reverse (no control of MSB sway) (Item 8.8)</p> <p>Process upset/malfunction (too much sway due to vessel course/speed) (Item 8.16)</p>	<p>Hazardous exposure - contact injury</p> <p>Person overboard</p> <p>Equipment damage/loss: damage to the MSB</p> <p>Equipment damage/loss: lose equipment overboard</p>	<p>Safety supervisor monitors evolution</p> <p>Deck supervisor directs hydraulic operator actions</p> <p>Frapping line tenders control MSB sway</p> <p>MSB hydraulic system undergoes periodic preventive maintenance</p> <p>Deck personnel not positioned under MSB when moved out</p> <p>Fall line failure considered unlikely since MSB not loaded at this point</p>	
8.11	Contact with/struck against		No consequences of interest		
8.12	Slip/trip/fall		No consequences of interest		
8.13	Stress/strain/fatigue		See general personnel fatigue issues		
8.14	Exposure to		See general personnel exposure issues		
8.15	Process upset/malfunction (equipment failure)	<p>Hydraulic failure</p> <p>Fall line (support line) failure</p>	Struck by/contact by (Item 8.10)		

Table D.1B MSB WISE Worksheets (continued)

Item Number	Deviation	Causes	Consequences	Safeguards	Recommendations
<b>8.0 STEP - MOVE THE MSB OUTBOARD (continued)</b>					
8.16	Process upset/ malfunction (too much sway due to vessel course/speed)	Improper launch course/speed (too much sway on MSB) - Same as Items 14.2 (Skip), 14.4 (Less), 14.6/7 (More) in the Establish Appropriate Launch Course step	Struck by/contact by (Item 8.10)		
8.17	Layout/traffic/siting		No consequences of interest		
8.18	Tools/equipment		No consequences of interest		
<b>9.0 STEP - TEND THE MSB FRAPPING LINES</b>					
9.1	Missing		No missing steps identified		
9.2	Skip		No consequences of interest		
9.3	Part of		No consequences of interest		
9.4	Less (too much line slack)	Frapping line tenders allow too much slack in frapping lines Deck supervisor accidently orders too much slack in frapping lines	Struck by/contact by (Item 9.10)		

Table D.1B MSB WISE Worksheets (continued)

Item Number	Deviation	Causes	Consequences	Safeguards	Recommendations
9.0 STEP - TEND THE MSB FRAPPING LINES (continued)					
9.5	More (too much line tension)	Frapping line tenders place too much tension on frapping lines Deck supervisor accidently orders too much tension on frapping lines	Struck by/contact by - MSB swaying if frapping line(s) snap or if MSB swings into vessel suddenly when drawn in by frapping line tenders (Item 9.10)		
9.6	Out of sequence		Process upset/malfunction (frapping lines break) (Item 9.15)		
9.6	Out of sequence		No consequences of interest		
9.7	As well as		No consequences of interest		
9.8	Other than/reverse		No consequences of interest		
9.9	Caught in/on/by/ between	Frapping line tender gets fingers/hands caught between the line and the cleat while controlling MSB sway	Hazardous exposure - contact injury	Safety supervisor monitors evolution New personnel supervised by experienced personnel alongside them	
9.10	Struck by/contact by	Less (Item 9.4) Process upset/malfunction (Item 9.15) More (Item 9.5)	Hazardous exposure - contact injury: personnel injury due to contact with swaying MSB Equipment damage/loss: damage to MSB	Safety supervisor monitors evolution Deck personnel not positioned under/near MSB when moved out MSB launch equipment periodically inspected	
9.11	Contact with/struck against		No consequences of interest		
9.12	Slip/trip/fall		No consequences of interest		

Table D.1B MSB WISE Worksheets (continued)

Item Number	Deviation	Causes	Consequences	Safeguards	Recommendations
<b>9.0 STEP - TEND THE MSB FRAPPING LINES (continued)</b>					
9.13	Stress/strain/fatigue		See general personnel fatigue issues		
9.14	Exposure to		See general personnel exposure issues		
9.15	Process upset/ malfunction (frapping lines break)	More (too much line tension) (Item 9.5) Frapping line defect	Struck by/contact by (Item 9.10)		
9.16	Layout/traffic/siting		No consequences of interest		
9.17	Tools/equipment		No consequences of interest		
<b>10.0 STEP - LOWER THE MSB BELOW THE RAIL</b>					
10.1	Missing		No missing steps identified		
10.2	Skip		No consequences of interest		
10.3	Part of		No consequences of interest		
10.4	Less		No consequences of interest		
10.5	More		No consequences of interest		

Table D.1B MSB WISE Worksheets (continued)

Item Number	Deviation	Causes	Consequences	Safeguards	Recommendations
10.0 STEP - LOWER THE MSB BELOW THE RAIL (continued)					
10.6	Out of sequence		Same as Less (MSB not moved out enough) in the Move the MSB Outboard step (Item 8.4)		
10.7	As well as		No consequences of interest		
10.8	Other than/reverse		No consequences of interest		
10.9	Caught in/on/by/ between		No consequences of interest		
10.10	Struck by/contact by	Frapping line tenders do not control sway of MSB - Same as Items 9.4 (Less) and 9.5 (More) in the Tend the MSB Frapping Lines step	Hazardous exposure - contact injury: personnel injury due to contact with swaying MSB Equipment damage/loss: damage to MSB	Safety/deck supervisor monitors evolution Deck personnel not positioned near MSB when lowered to rail	
10.11	Contact with/struck against		No consequences of interest		
10.12	slip/trip/fall		No consequences of interest		
10.13	Stress/strain/fatigue		See general personnel fatigue issues		
10.14	Exposure to		See general personnel exposure issues		
10.15	Process upset/ malfunction		Same as Process upset/malfunction in the Move the MSB Outboard step (Item 8.15)		

Table D.1B MSB WISE Worksheets (continued)

Item Number	Deviation	Causes	Consequences	Safeguards	Recommendations
10.0 STEP - LOWER THE MSB BELOW THE RAIL (continued)					
10.16	Layout/traffic/siting		No consequences of interest		
10.17	Tools/equipment		No consequences of interest		
11.0 STEP - SHUG THE MSB AGAINST THE RAIL					
11.1	Missing		No missing steps identified		
11.2	Skip		No consequences of interest		
11.3	Part of		No consequences of interest		
11.4	Less (MSB loses grip on side of vessel)	Wet/icy conditions on side of vessel	Equipment damage/loss: damage to side of MSB	Deicing agents and ice removal practices	9
11.5	More	Boom/winch operator moves MSB to rail too fast Deck supervisor accidentally orders MSB moved to rail too fast	Hazardous exposure - contact injury: personnel slip/trip/fall during the Load/Man the MSB step (Item 12.12) Equipment damage/loss: damage to the MSB	Safety supervisor monitors evolution	
11.6	Out of sequence		No consequences of interest		

Table D.1B MSB WISE Worksheets (continued)

Item Number	Deviation	Causes	Consequences	Safeguards	Recommendations
11.0 STEP - SNUG THE MSB AGAINST THE RAIL (continued)					
11.7	As well as		No consequences of interest		
11.8	Other than/reverse		No consequences of interest		
11.9	Caught in/on/by/ between		No consequences of interest		
11.10	Struck by/contact by		No consequences of interest		
11.11	Contact with/struck against		Same as More		
11.12	slip/trip/fall		No consequences of interest		
11.13	Stress/strain/fatigue		See general personnel fatigue issues		
11.14	Exposure to		See general personnel exposure issues		
11.15	Process upset/ malfunction		No consequences of interest		
11.16	Layout/traffic/siting		No consequences of interest		
11.17	Tools/equipment		No consequences of interest		

Table D.1B MSB WISE Worksheets (continued)

Item Number	Deviation	Causes	Consequences	Safeguards	Recommendations
12.0 STEP - LOAD/MAN THE MSB					
12.1	Missing		No missing steps identified		
12.2	skip		No consequences of interest		
12.3	Part of		No consequences of interest		
12.4	Less		No consequences of interest		
12.5	More	Overload MSB with people/equipment	Person overboard and/or equipment damage/loss (MSB or lose gear overboard) if one/both fall (lines break		Safety and deck supervisors limit number of persons (?) in MSB at this point
12.6	Out of sequence		Same as slip/trip/fall (out of sequence with the Snug the MSB Against the Rail step)		
12.7	As well as		No consequences of interest		
12.8	Other than/reverse		No consequences of interest		
12.9	Caught in/on/by/between		No consequences of interest		
12.10	Struck by/contact by		No consequences of interest		



Table D.1B MSB WISE Worksheets (continued)

Item Number	Deviation	Causes	Consequences	Safeguards	Recommendations
12.0 STEP - LOAD/MAN THE MSB (continued)					
12.11	Contact with/struck against	No consequences of interest			
12.12	Slip/trip/fall	<p>Personnel slip/trip/fall while loading into MSB due to high winds/seas/icy conditions</p> <p>MSB loses grip on side of vessel in the Snug the MSB Against the Rail step (Item 11.4)</p>	<p>Person overboard</p> <p>Equipment damage/loss: lose equipment overboard</p>	<p>Safety and deck supervisors monitor evolution</p> <p>Deicing agents and ice removal practices</p>	9
12.13	Stress/strain/fatigue	See general personnel fatigue issues			
12.14	Exposure to	See general personnel exposure issues			
12.15	Process upset/malfunction	No consequences of interest			
12.16	Layout/traffic/siting	No consequences of interest			
12.17	Tools/equipment	No consequences of interest			

Table D.1B MSB WISE Worksheets (continued)

Item Number	Deviation	Causes	Consequences	Safeguards	Recommendations
13.0 STEP - MAN THE MSB "MONKEY LINES"					
13.1	Missing		No missing steps identified		
13.2	Skip	Personnel in MSB do not support their weight on monkey lines	Person overboard; personnel overboard if one/both MSB fall lines break or due to sway  Hazardous exposure - contact injury: personnel get hands/legs caught between swaying MSB and hull of vessel	Personnel specifically trained to hold on to monkey lines  MSB launch equipment periodically inspected  Safety and deck supervisors monitor loading of MSB  Frapping line tenders limit sway on MSB	
13.3	Part of		Same as Skip		
13.4	Less		Same as Skip		
13.5	More		No consequences of Interest		
13.6	Out of sequence		No consequences of Interest		
13.7	As well as		No consequences of Interest		
13.8	Other than/reverse		No consequences of Interest		
13.9	Caught in/on/by/between		No consequences of Interest		

Table D.1B MSB WISE Worksheets (continued)

Item Number	Deviation	Causes	Consequences	Safeguards	Recommendations
13.0 STEP - MAN THE MSB "MONKEY LINES" (continued)					
13.10	Struck by/contact by		No consequences of interest		
13.11	Contact with/struck against		No consequences of interest		
13.12	Slip/trip/fall	Boat crew loses balance while grabbing monkey lines	Person overboard	New personnel supervised by experienced personnel alongside them Safety and deck supervisor monitor the evolution	
13.13	Stress/strain/fatigue		See general personnel fatigue issues		
13.14	Exposure to		See general personnel exposure issues		
13.15	Process upset/malfunction		No consequences of interest		
13.16	Layout/traffic/siting		No consequences of interest		
13.17	Tools/equipment		No consequences of interest		

Table D.1B MSB WISE Worksheets (continued)

Item Number	Deviation	Causes	Consequences	Safeguards	Recommendations
14.0 STEP - ESTABLISH APPROPRIATE LAUNCH COURSE/SPEED					
14.1	Missing	No missing steps identified			
14.2	Skip	Deck crew launches the MSB without permission from bridge Bridge permits launch before course established	Person overboard and/or equipment damage/loss (MSB or lose gear overboard) due to excessive sway, high seas/winds Person overboard and/or equipment damage/loss (MSB or lose gear overboard) if vessel has to perform an emergency breakaway from course/speed	Multiple people on the bridge Safety supervisor monitors the evolution and can communicate with the bridge	
14.3	Part of		No consequences of interest		
14.4	Less (steering too little in intended direction)	Bridge misreads weather direction Conning officer orders wrong direction Helmsman sets wrong direction or drifts Steering system equipment failure	Collision with another vessel Potential for MSB to enter hazardous area (e.g., fishing area) during or after launch, (Person overboard and/or equipment damage/loss)	Multiple people on the bridge Safety supervisor monitors the evolution and can communicate with the bridge	
14.5	Less (too little speed)		No consequences of interest		
14.6	More (steering too far in intended direction)		Same as Less (steering)		

Table D.1B MSB WISE Worksheets (continued)

Item Number	Deviation	Causes	Consequences	Safeguards	Recommendations
14.0 STEP - ESTABLISH APPROPRIATE LAUNCH COURSE/SPEED (continued)					
14.7	More (too much speed)	Bridge misreads weather conditions Conning officer orders wrong speed Helmsman sets wrong speed	Person overboard and/or hazardous exposure - contact injury and/or equipment damage/loss	Safety supervisor monitors the evolution and can communicate with the bridge  Multiple people on the bridge	
14.8	Out of sequence		No consequences of interest		
14.9	As well as		No consequences of interest		
14.10	Other than/reverse		No consequences of interest		
14.11	Caught in/on/by/between		No consequences of interest		
14.12	Struck by/contact by		No consequences of interest		
14.13	Contact with/struck against		No consequences of interest		
14.14	Slip/trip/fall		No consequences of interest		
14.15	Stress/strain/fatigue		No consequences of interest		
14.16	Exposure to		No consequences of interest		

Table D.1B MSB WISE Worksheets (continued)

Item Number	Deviation	Causes	Consequences	Safeguards	Recommendations
14.0 STEP - ESTABLISH APPROPRIATE LAUNCH COURSE/SPEED (continued)					
14.17	Process upset/ malfunction		No consequences of interest		
14.18	Layout/traffic/siting		No consequences of interest		
14.19	Tools/equipment		No consequences of interest		
15.0 STEP - SWING THE MSB CLEAR OF THE HULL					
15.1	Missing		No missing steps identified		
15.2	Skip	Deck supervisor orders MSB lowered without having it swung clear of the hull  Davit/winch operator inadvertently lowers MSB while snugged to hull	Person overboard and/or equipment damage/loss (overboard) due to RHI tilting	Safety supervisor monitors evolution  Boat crew feedback to deck supervisor if MSB starts tilting	
15.3	Part of		No consequences of interest		
15.4	Less		No consequences of interest		

Table D.1B MSB WISE Worksheets (continued)

Item Number	Deviation	Causes	Consequences	Safeguards	Recommendations
15.0 STEP - SWING THE MSB CLEAR OF THE HULL (continued)					
15.5	More (swing MSB out too fast)	<p>Hydraulic/winch operator accidentally swings MSB out too fast</p> <p>Deck supervisor accidentally orders MSB swung out too fast</p> <p>Deck supervisor fails to request permission from the bridge to lower the MSB (out of sequence from establishing launch course/speed)</p>	<p>Person overboard and/or equipment damage/loss (MSB or lose gear overboard) due to excessive sway</p> <p>Caught in/on/by/between (Item 15.9)</p> <p>Struck by/contact by (Item 15.10)</p>	<p>Safety supervisor and deck supervisor monitor evolution</p> <p>Boat crew feedback to deck supervisor</p> <p>Frapping line tenders limit sway on MSB</p>	<p>Boat crew specifically trained to hold on to monkey lines while MSB in the air or hooked to vessel</p> <p>Bridge Deck officer can order MSB lowering stopped if order to lower not given</p>
15.6	Out of sequence (swing MSB outboard before launch course established)	<p>Same as More</p> <p>Same as Skip in the Establish Appropriate Launch Course/Speed step (Item 14.2)</p>	<p>Same as More</p> <p>Same as Skip in the Establish Appropriate Launch Course/Speed step (Item 14.2)</p>		
15.7	As well as		No consequences of interest		
15.8	Other than/reverse		No consequences of interest		
15.9	Caught in/on/by/ between	More (swing MSB out too fast) (Item 15.5)	Hazardous exposure - contact injury: hands/fingers caught between MSB and hull	<p>Safety supervisor and deck supervisor monitor evolution</p> <p>Frapping line tenders limit sway on MSB</p>	<p>Boat crew specifically trained to hold onto monkey lines</p>

Table D.18 MSB WISE Worksheets (continued)

Item Number	Deviation	Causes	Consequences	Safeguards	Recommendations
15.0 STEP - SWING THE MSB CLEAR OF THE HULL (continued)					
15.10	Struck by/contact by	More (swing MSB out too fast) (Item 15.5)	Hazardous exposure - contact injury: personnel injury when MSB hits hull	Safety supervisor and deck supervisor monitor evolution Frapping line tenders limit sway on MSB Boat crew specifically trained to hold on to monkey lines	
15.11	Contact with/struck against		No consequences of interest		
15.12	Slip/trip/fall		See More		
15.13	Stress/strain/fatigue		See general personnel fatigue issues		
15.14	Exposure to		See general personnel exposure issues		
15.15	Process upset/ malfunction		No consequences of interest		
15.16	Layout/traffic/siting		No consequences of interest		
15.17	Tools/equipment		No consequences of interest		



Table D.1B MSB HISE Worksheets (continued)

Item Number	Deviation	Causes	Consequences	Safeguards	Recommendations
16.0 STEP - LOWER THE MSB					
16.1	Missing		No missing steps identified		
16.2	Skip		No consequences of interest		
16.3	Part of		No consequences of interest		
16.4	Less	Hydraulic/winch suddenly stops lowering MSB Deck supervisor orders sudden stop in lowering MSB	Person overboard and/or equipment damage/loss: due to sudden stop or one/both fall line(s) break(s) due to sudden stop	Safety supervisor monitors evolution Proper launch course reduces chance of having to stop lowering suddenly Boat crew specifically trained to hold on to monkey lines while MSB in the air or hooked to vessel	
16.5	More	Hydraulic/winch operator lowers MSB too fast for sea conditions Deck supervisor orders too-fast lowering of MSB	Person overboard and/or equipment damage/loss due to impact when hitting the water	Safety supervisor monitors evolution Proper launch course reduces chance of having to lower too fast Boat crew specifically trained to hold on to monkey lines while MSB in the air or hooked to vessel	
16.6	Out of sequence		Same as Skip in the steps Establish Appropriate Launch Course/Speed (Item 14.2) and Swing the MSB Clear of the Hull (Item 15.2)		
16.7	As well as		No consequences of interest		
16.8	Other than/reverse		No consequences of interest		

Table D.1B MSB WISE Worksheets (continued)

Item Number	Deviation	Causes	Consequences	Safeguards	Recommendations
16.0 STEP - LOWER THE MSB (continued)					
16.9	Caught in/on/by/ between	Monkey lines mispositioned  Personnel in MSB do not support their weight on monkey lines - Same as Item 13.2 (Skip) in the Man the MSB Monkey Lines step	Hazardous exposure - contact injury: boat crew caught in monkey line  Equipment damage/loss: line caught on equipment (fire extinguisher, cleat, etc.)	Safety and deck supervisors monitor the evolution  Boat crew specifically trained to hold on to monkey lines while MSB in the air or hooked to vessel	
16.10	Struck by/contact by	High wave strikes MSB  Process upset/malfunction (fall line or winch failure) (Item 16.15)  Frapping line tenders do not control sway of MSB - Same as Items 9.4 (Less) and 9.5 (More) in the Tend the MSB Frapping Lines step  Improper launch course/speed (too much sway on MSB) - Same as Items 14.2 (Skip), 14.4/5 (Less), 14.6/7 (More) in the Establish Appropriate Launch Course step	Hazardous exposure - contact injury: hands/fingers caught between MSB and hull of vessel  Equipment damage/loss: damage to MSB (sway or dropped)  Person overboard  Equipment damage/loss: lose equipment overboard	Frapping line tenders limit sway of MSB  Proper launch course reduces excessive sway when lowering  Boat crew specifically trained to hold on to monkey lines  Preventive maintenance and inspections on fall lines and electric winch	
16.11	Contact with/struck against		Same as More		
16.12	Slip/trip/fall		Same as Struck by/contact by		
16.13	Stress/strain/fatigue		See general personnel fatigue issues		
16.14	Exposure to		See general personnel exposure issues		

Table D.1B MSB WISE Worksheets (continued)

Item Number	Deviation	Causes	Consequences	Safeguards	Recommendations
16.0 STEP - LOWER THE MSB (continued)					
16.15	Process upset/ malfunction (fall line or winch failure)	Fall line (support line) failure (MSB overloaded)  Electric winch failure	Struck by/contact by (Item 16.10)  Person(s) overboard if one/both fall lines break	Safety and deck supervisors limit number of persons (7) in MSB when loading	
16.16	Layout/traffic/siting		No consequences of interest		
16.17	Tools/equipment		No consequences of interest		
17.0 STEP - RETRIEVE THE "MONKEY LINES"					
17.1	Missing		No missing steps identified		
17.2	Skip	Deck supervisor fails to order lines brought in	Equipment damage/loss: damage clear if line is caught on MSB  Equipment damage/loss: could make the MSB unstable (capsize) if a line is caught on the MSB  Hazardous exposure - contact injury: personnel injury/fall due to line parting or suddenly coming free	Multiple people involved in the deck evolution who can notice that not all monkey lines are retrieved  Boat crew can unhook line	
17.3	Part of		Same as Skip		
17.4	Less		Same as Skip		
17.5	More		No consequences of interest		

Table D.1B MSB WISE Worksheets (continued)

Item Number	Deviation	Causes	Consequences	Safeguards	Recommendations
17.0 STEP - RETRIEVE THE "MONKEY LINES" (continued)					
17.6	Out of sequence		No consequences of interest		
17.7	As well as		No consequences of interest		
17.8	Other than/reverse		No consequences of interest		
17.9	Caught in/on/by/ between		No consequences of interest		
17.10	Struck by/contact by		Same as Skip		
17.11	Contact with/struck against		No consequences of interest		
17.12	slip/trip/fall		Same as Skip		
17.13	Stress/strain/fatigue		See general personnel fatigue issues		
17.14	Exposure to		See general personnel exposure issues		
17.15	Process upset/ malfunction		No consequences of interest		
17.16	Layout/traffic/siting		No consequences of interest		
17.17	Tools/equipment		No consequences of interest		

Table D.1B MSB WISE Worksheets (continued)

Item Number	Deviation	Causes	Consequences	Safeguards	Recommendations
18.0 STEP - START THE MSB ENGINE					
18.1	Missing		No missing steps identified		
18.2	Skip		No consequences of interest		
18.3	Part of		No consequences of interest		
18.4	Less		No consequences of interest		
18.5	More		No consequences of interest		
18.6	Out of sequence	Coxswain starts MSB engine before MSB fully in water	Equipment damage/Loss: damage MSB engine due to overheating	MSB engine can run a few minutes without cooling	Coxswain hanging onto monkey line until MSB in water (hands are busy)
18.7	As well as		No consequences of interest		
18.8	Other than/reverse		No consequences of interest		
18.9	Caught in/on/by/between		No consequences of interest		
18.10	Struck by/contact by		No consequences of interest		

Table D.1B MSB WISE Worksheets (continued)

Item Number	Deviation	Causes	Consequences	Safeguards	Recommendations
18.0 STEP - START THE MSB ENGINE (continued)					
18.11	Contact with/struck against	Process upset/malfunction (engine fails to start) (Item 18.15)	Hazardous exposure - contact injury and/or equipment damage/loss: MSB collides with hull of vessel due to no propulsion	Properly completing morning boat checks Preventive maintenance on MSB systems Safety/deck supervisor monitors evolution (can raise MSB back up)	
18.12	Slip/trip/fall		No consequences of interest		
18.13	Stress/strain/fatigue		See general personnel fatigue issues		
18.14	Exposure to		See general personnel exposure issues		
18.15	Process upset/malfunction (engine fails to start)	Engine too cold Fuel not getting to MSB engine (water freezing or fuel line plugged up)	Contact with/struck against (Item 18.11)		
18.16	Layout/traffic/siting		No consequences of interest		
18.17	Tools/equipment		No consequences of interest		

Table D.1B MSB WISE Worksheets (continued)

Item Number	Deviation	Causes	Consequences	Safeguards	Recommendations
19.0 STEP - RELEASE THE MSB FROM THE FALL LINES					
19.1	Missing		No missing steps identified		
19.2	Skip	Coxswain attempts to pull away without releasing fall lines	Person overboard and/or equipment damage/loss: capsize MSB	Multiple personnel in the MSB and on deck make this event very unlikely	
19.3	Part of		Same as Out of sequence		
19.4	Less		Same as Out of sequence		
19.5	More		No consequences of interest		
19.6	Out of sequence (forward fall line released before the after fall line)	Erroneous order by coxswain Boat crew error	Person overboard and/or equipment damage/loss: capsize MSB	Multiple personnel in the MSB and on deck make this event very unlikely Morning boat checks of deck equipment	
19.7	As well as		No consequences of interest		
19.8	Other than/reverse		Same as Out of sequence		
19.9	Caught in/on/by/between		No consequences of interest		

Table D.18 MSB WISE Worksheets (continued)

Item Number	Deviation	Causes	Consequences	Safeguards	Recommendations
19.0 STEP - RELEASE THE MSB FROM THE FALL LINES (continued)					
19.10	Struck by/contact by	Boat crew error High seas	Hazardous exposure - contact injury: struck by falls	New personnel supervised by experienced personnel alongside them	5
				Boat crew wears hardhats	
				Coxswain monitors evolution	
				Frapping line tenders limit sway of fall lines	
19.11	Contact with/struck against		No consequences of interest		
19.12	Slip/trip/fall		No consequences of interest		
19.13	Stress/strain/fatigue		See general personnel fatigue issues		
19.14	Exposure to		See general personnel exposure issues		
19.15	Process upset/ malfunction		No consequences of interest		
19.16	Layout/traffic/siting		No consequences of interest		
19.17	Tools/equipment		No consequences of interest		



Table D.1B MSB WISE Worksheets (continued)

Item Number	Deviation	Causes	Consequences	Safeguards	Recommendations
20.0 STEP - CONTROL THE BLOCKS					
20.1	Missing		No missing steps identified		
20.2	Skip		Same as Struck by/contact by		
20.3	Part of		Same as Struck by/contact by		
20.4	Less		Same as Struck by/contact by		
20.5	More		No consequences of interest		
20.6	Out of sequence		No consequences of interest		
20.7	As well as		No consequences of interest		
20.8	Other than/reverse		No consequences of interest		
20.9	Caught in/on/by/ between		No consequences of interest		
20.10	Struck by/contact by	Frapping line tenders do not control fall line tension (sway of blocks) - Same as Items 9.4 (Less) and 9.5 (More) in the Tend the MSB Frapping Lines step	Hazardous exposure - contact injury: personnel injury (boat crew) from block evolution	Safety/Deck supervisor monitors	
20.11	Contact with/struck against		No consequences of interest		

Table D.1B MSB WISE Worksheets (continued)

Item Number	Deviation	Causes	Consequences	Safeguards	Recommendations
<b>20.0 STEP - CONTROL THE BLOCKS (continued)</b>					
20.12	Slip/trip/fall		No consequences of interest		
20.13	Stress/strain/fatigue		See general personnel fatigue issues		
20.14	Exposure to		See general personnel exposure issues		
20.15	Process upset/ malfunction		No consequences of interest		
20.16	Layout/traffic/siting		No consequences of interest		
20.17	Tools/equipment		No consequences of interest		
<b>21.0 STEP - MANEUVER THE MSB AWAY FROM THE VESSEL AND FORWARD</b>					
21.1	Missing		No missing steps identified		
21.2	Skip		No consequences of interest		
21.3	Part of		No consequences of interest		

Table D.1B MSB WISE Worksheets (continued)

Item Number	Deviation	Causes	Consequences	Safeguards	Recommendations
21.0 STEP - MANEUVER THE MSB AWAY FROM THE VESSEL AND FORWARD (continued)					
21.4	Less (MSB propulsion)	Coxswain underpowers MSB when maneuvering away Stuck throttles	Contact with/struck against - MSB collides with hull of vessel (Item 21.12)	New personnel supervised by experienced personnel alongside them Safety/deck supervisor monitors evolution	
21.5	More (MSB propulsion)	Coxswain overpowers MSB when maneuvering away Stuck throttles	Contact with/struck against - MSB hits waves (Item 21.12) Person overboard and/or equipment damage/loss due to capsizing MSB	New personnel supervised by experienced personnel alongside them Safety/deck supervisor monitors evolution	
21.6	More (MSB steering)	Coxswain maneuvers MSB into vessel	Contact with/struck against (Item 21.12)	Throttles operated during morning boat checks	
21.7	Out of sequence		Same as Skip in the Release the MSB from the Fall Lines step (Item 19.2)		
21.8	As well as		No consequences of interest		
21.9	Other than/reverse		No consequences of interest		
21.10	Caught in/on/by/ between		No consequences of interest		
21.11	Struck by/contact by		No consequences of interest		

Table D.1B MSB WISE Worksheets (continued)

Item Number	Deviation	Causes	Consequences	Safeguards	Recommendations
21.0 STEP - MANEUVER THE MSB AWAY FROM THE VESSEL AND FORWARD (continued)					
21.12	Contact with/struck against	Less (MSB propulsion) (Item 21.4) More (MSB propulsion) (Item 21.5) More (MSB steering) (Item 21.6)	Hazardous exposure - contact injury and/or equipment damage (MSB) due to MSB colliding with hull of vessel Hazardous exposure - contact injury or person overboard due to wave impacts	New personnel supervised by experienced personnel alongside them Safety/deck supervisor monitors evolution	
21.13	slip/trip/fall		No consequences of interest		
21.14	Stress/strain/fatigue		See general personnel fatigue issues		
21.15	Exposure to		See general personnel exposure issues		
21.16	Process upset/malfunction		No consequences of interest		
21.17	Layout/traffic/siting		No consequences of interest		
21.18	Tools/equipment		No consequences of interest		

Table D.1B MSB WISE Worksheets (continued)

Item Number	Deviation	Causes	Consequences	Safeguards	Recommendations
22.0 STEP - RELEASE THE SEA PAINTER					
22.1	Missing		No missing steps identified		
22.2	skip	Coxswain fails to order sea painter released Forward boat crewman fails to release sea painter	Person overboard and/or equipment overboard due to capsizing MSB	Safety/deck supervisor monitors evolution Forward boat crewman can warn coxswain Coxswain awaits report from the forward boat crewman that the sea painter is released	
22.3	Part of		No consequences of interest		
22.4	Less		No consequences of interest		
22.5	More		No consequences of interest		
22.6	Out of sequence		Same as Less (MSB propulsion) in the Maneuver the MSB Away from the Vessel and Forward step (Item 21.4)		
22.7	As well as		No consequences of interest		
22.8	Other than/reverse		No consequences of interest		

Table D.1B MSB WISE Worksheets (continued)

Item Number	Deviation	Causes	Consequences	Safeguards	Recommendations
<b>22.0 STEP - RELEASE THE SEA PAINTER (continued)</b>					
22.9	Caught in/on/by/ between	Boat crewman inattention when releasing sea painter	Hazardous exposure - contact injury: personnel injury if caught in line	Boat crew trained specifically on how to avoid placing hands in vulnerable position	10
22.10	Struck by/contact by		No consequences of interest		
22.11	Contact with/struck against		No consequences of interest		
22.12	Slip/trip/fall		No consequences of interest		
22.13	Stress/strain/fatigue		See general personnel fatigue issues		
22.14	Exposure to		See general personnel exposure issues		
22.15	Process upset/ malfunction		No consequences of interest		
22.16	Layout/traffic/siting		No consequences of interest		
22.17	Tools/equipment		No consequences of interest		

Table D.1B MSB WISE Worksheets (continued)

Item Number	Deviation	Causes	Consequences	Safeguards	Recommendations
23.0 STEP - PREPARE THE SEA PAINTER FOR PASSING					
23.1	Missing		No missing steps identified		
23.2	Skip		Same as Skip in Pass the Sea Painter step (see Item 28.2)		
23.3	Part of		No consequences of interest		
23.4	Less		No consequences of interest		
23.5	More		No consequences of interest		
23.6	Out of sequence		No consequences of interest		
23.7	As well as		No consequences of interest		
23.8	Other than/reverse		No consequences of interest		
23.9	Caught in/on/by/ between		No consequences of interest		
23.10	Struck by/contact by		No consequences of interest		
23.11	Contact with/struck against		No consequences of interest		

Table D.1B MSB WISE Worksheets (continued)

Item Number	Deviation	Causes	Consequences	Safeguards	Recommendations
23.0 STEP - PREPARE THE SEA PAINTER FOR PASSING (continued)					
23.12	slip/trip/fall		No consequences of interest		
23.13	Stress/strain/fatigue		No consequences of interest		
23.14	Exposure to		No consequences of interest		
23.15	Process upset/ malfunction		No consequences of interest		
23.16	Layout/traffic/siting		No consequences of interest		
23.17	Tools/equipment		No consequences of interest		
24.0 STEP - MAN THE MSB RECOVERY STATIONS					
24.1	Missing		No missing steps identified		
24.2	skip		No consequences of interest		
24.3	Part of		Same as Part of in the Man the MSB Launch Stations step (see Item 4.3)		
24.4	Less		Same as Part of in the Man the MSB Launch Stations step (Item 4.3)		



Table D.1B MSB WISE Worksheets (continued)

Item Number	Deviation	Causes	Consequences	Safeguards	Recommendations
24.0 STEP - MAN THE MSB RECOVERY STATIONS (continued)					
24.5	None		No consequences of interest		
24.6	Out of sequence		No consequences of interest		
24.7	As well as		No consequences of interest		
24.8	Other than/reverse		Same as Other than/reverse in the Man the MSB Launch Stations step (Item 4.8)		
24.9	Caught in/on/by/ between		No consequences of interest		
24.10	Struck by/contact by		No consequences of interest		
24.11	Contact with/struck against		No consequences of interest		
24.12	Slip/trip/fall		Same as Slip/trip/fall in the Man the MSB Launch Stations step (Item 4.12)		
24.13	Stress/strain/fatigue		See general personnel fatigue issues		
24.14	Exposure to		See general personnel exposure issues		
24.15	Process upset/ malfunction		No consequences of interest		

Table D.18 MSB WISE Worksheets (continued)

Item Number	Deviation	Causes	Consequences	Safeguards	Recommendations
24.0 STEP - MAN THE MSB RECOVERY STATIONS (continued)					
24.16	Layout/traffic/siting		No consequences of interest		
24.17	Tools/equipment		No consequences of interest		
25.0 STEP - PROVIDE ENOUGH SLACK IN THE FALL LINES FOR RAPID MSB RECOVERY					
25.1	Missing		No missing steps identified		
25.2	Skip		Same as Less		
25.3	Part of		Same as Less		
25.4	Less		Same as Contact with/struck against		
25.5	More		No consequences of interest		
25.6	Out of sequence		No consequences of interest		
25.7	As well as		No consequences of interest		
25.8	Other than/reverse		No consequences of interest		
25.9	Caught in/on/by/ between		No consequences of interest		

Table D.1B MSB WISE Worksheets (continued)

Item Number	Deviation	Causes	Consequences	Safeguards	Recommendations
25.0 STEP - PROVIDE ENOUGH SLACK IN THE FALL LINES FOR RAPID MSB RECOVERY (continued)					
25.10	Struck by/contact by		No consequences of interest		
25.11	Contact with/struck against	Frapping line tenders do not control fall line tension - Same as item 9.5 (More) in the Tend the MSB Frapping Lines step	Hazardous exposure - contact injury and/or equipment damage/loss (MSB) due to MSB colliding with hull of vessel	New personnel supervised by experienced personnel alongside them Safety supervisor and deck supervisor monitor evolution	
25.12	Slip/trip/fall		No consequences of interest		
25.13	Stress/strain/fatigue		See general personnel fatigue issues		
25.14	Exposure to		See general personnel exposure issues		
25.15	Process upset/malfunction		No consequences of interest		
25.16	Layout/traffic/siting		No consequences of interest		
25.17	Tools/equipment		No consequences of interest		

Table D.1B MSB WISE Worksheets (continued)

Item Number	Deviation	Causes	Consequences	Safeguards	Recommendations
26.0 STEP - ESTABLISH MSB RECOVERY COURSE/SPEED					
26.1	Missing		No missing steps identified		
26.2	Skip		Same as Skip in the Establish Appropriate Launch Course/Speed step (see Item 14.2)		
26.3	Part of		No consequences of interest		
26.4	Less (steering too little in the intended direction)		Same as Less in the Establish Appropriate Launch Course/Speed step (see Item 14.4)		
26.5	Less (too little speed)		No consequences of interest		
26.6	More (steering too far in the intended direction)		Same as Less (steering Item 26.4)		
26.7	More (too much speed)		Same as More (too much speed) in the Establish Appropriate Launch Course step (Item 14.7)		
26.8	Out of sequence		No consequences of interest		
26.9	As well as		No consequences of interest		
26.10	Other than/reverse		No consequences of interest		

Table D.1B MSB WISE Worksheets (continued)

Item Number	Deviation	Causes	Consequences	Safeguards	Recommendations
26.0 STEP - ESTABLISH MSB RECOVERY COURSE/SPEED (continued)					
26.11	Caught in/on/by/ between		No consequences of interest		
26.12	Struck by/contact by		No consequences of interest		
26.13	Contact with/struck against		No consequences of interest		
26.14	Slip/trip/fall		No consequences of interest		
26.15	Stress/strain/fatigue		No consequences of interest		
26.16	Exposure to		No consequences of interest		
26.17	Process upset/ malfunction		No consequences of interest		
26.18	Layout/traffic/siting		No consequences of interest		
26.19	Tools/equipment		No consequences of interest		

Table D.1B MSB WISE Worksheets (continued)

Item Number	Deviation	Causes	Consequences	Safeguards	Recommendations
27.0 STEP - MANEUVER THE MSB ALONGSIDE THE VESSEL					
27.1	Missing		No missing steps identified		
27.2	Skip		No consequences of interest		
27.3	Part of		No consequences of interest		
27.4	Less (MSB propulsion)	Coxswain underpowers MSB when maneuvering alongside Stuck throttles	Contact with/struck against (same as Less [Item 21.4] in the Maneuver MSB Away From the Vessel and Forward step) (Item 27.12)		
27.5	More (MSB propulsion)	Coxswain overpowers MSB when maneuvering alongside Stuck throttles	Contact with/struck against (Item 27.12)		
27.6	More (MSB steering)	Coxswain maneuvers MSB into vessel	Contact with/struck against (Item 27.12)		
27.7	Out of sequence		No consequences of interest		
27.8	As well as		No consequences of interest		
27.9	Other than/reverse		No consequences of interest		
27.10	Caught in/on/by/between		No consequences of interest		

Table D.1B MSB WISE Worksheets (continued)

Item Number	Deviation	Causes	Consequences	Safeguards	Recommendations
27.0 STEP - MANEUVER THE MSB ALONGSIDE THE VESSEL (continued)					
27.11	Struck by/contact by		No consequences of interest		
27.12	Contact with/struck against	More (too much speed) (Item 27.5) Less (too little speed) (Item 27.4) More (MSB steering) (Item 27.6)	Person overboard and/or equipment damage/loss (overboard) due to MSB colliding with hull of vessel (More and Less speed) Person overboard and/or equipment damage/loss (overboard) due to hitting waves (More speed) Equipment damage/loss (MSB) due to MSB colliding with hull of vessel (More speed)	New personnel supervised by experienced personnel alongside them Safety supervisor and deck supervisor monitor evolution Stuck throttles considered unlikely since MSB coming in from operation	
27.13	Slip/trip/fall	High sea state Boat crewman error	Person overboard when positioning for recovery	Boat crew kneels/crouches down to position for recovery Coxswain monitors boat crew	
27.14	Stress/strain/fatigue		See general personnel fatigue issues		
27.15	Exposure to		See general personnel exposure issues		
27.16	Process upset/malfunction		No consequences of interest		
27.17	Layout/traffic/siting		No consequences of interest		
27.18	Tools/equipment		No consequences of interest		

Table D.1B MSB WISE Worksheets (continued)

Item Number	Deviation	Causes	Consequences	Safeguards	Recommendations
28.0 STEP - PASS THE SEA PAINTER					
28.1	Missing		No missing steps identified		
28.2	Skip	Sea painter comes loose Recovering without the sea painter	Equipment damage/loss: potential to damage davit arms Person overboard and equipment damage/loss: potential to capsize the MSB	Vessel can rig another line if sea painter lost Boat crew would remind the vessel if sea painter not present	
28.3	Part of		No consequences of interest		
28.4	Less		No consequences of interest		
28.5	More		No consequences of interest		
28.6	Out of sequence		Same as Skip in the Establish Appropriate Launch Course/Speed step (Item 14.2)		
28.7	As well as		No consequences of interest		
28.8	Other than/reverse		No consequences of interest		



Table D.1B MSB WISE Worksheets (continued)

Item Number	Deviation	Causes	Consequences	Safeguards	Recommendations
28.0 STEP - PASS THE SEA PAINTER (continued)					
28.9	Caught in/on/by/between	Boat crew misses sea painter when passed Boat crewman error when hooking up sea painter	Equipment damage/loss: Seapainter caught in propeller of MSB Hazardous exposure - contact injury: hands/fingers caught in sea painter	Coxswain can throttle back if sea painter misses MSB New personnel supervised by experienced personnel alongside them Coxswain can monitor forward boat crewman	10
28.10	Struck by/contact by		No consequences of interest		
28.11	Contact with/struck against		No consequences of interest		
28.12	Slip/trip/fall	High sea state Boat crewman error	Person overboard when reaching for sea painter	Boat crew kneels to reach for sea painter Coxswain monitors boat crew	
28.13	Stress/strain/fatigue		See general personnel fatigue issues		
28.14	Exposure to		See general personnel exposure issues		
28.15	Process upset/malfunction		No consequences of interest		
28.16	Layout/traffic/siting		No consequences of interest		
28.17	Tools/equipment		No consequences of interest		

Table D.18 MSB WISE Worksheets (continued)

Item Number	Deviation	Causes	Consequences	Safeguards	Recommendations
<b>29.0 STEP - POSITION THE MSB DIRECTLY UNDER THE FALL LINES</b>					
29.1	Missing		No missing steps identified		
29.2	Skip		No consequences of interest		
29.3	Part of		No consequences of interest		
29.4	Less (too little power)	Coxswain error Stuck throttles	Equipment damage/loss: Too much tension on the sea painter (may break sea painter)	Multiple people involved in the evolution who can notice that MSB not positioned correctly  New personnel supervised by experienced personnel alongside them	
29.5	Less (too little rudder)	MSB rudder position not enough to compensate for vessel (cutter) rudder and vessel direction	Equipment damage/loss: capsize boat	Throttles operated during morning boat checks  Coxswain can use throttles to compensate  Multiple people involved in the evolution who can notice that MSB not positioned correctly	New personnel supervised by experienced personnel alongside them

Table D.1B MSB WISE Worksheets (continued)

Item Number	Deviation	Causes	Consequences	Safeguards	Recommendations
29.0 STEP - POSITION THE MSB DIRECTLY UNDER THE FALL LINES (continued)					
29.6	More (too much power)	Slack that causes jerking in the sea painter Coxswain error Stuck throttles	Equipment damage/loss: capsize boat Contact with/struck against (Item 29.13) Fouled screw: MSB runs over the sea painter	Multiple people involved in the evolution who can notice that MSB not positioned correctly New personnel supervised by experienced personnel alongside them Throttles operated during morning boat checks	
29.7	More (too much rudder)	Coxswain error	Equipment damage/loss: capsize boat Contact with/struck against (Item 29.13)	Multiple people involved in the evolution who can notice that MSB not positioned correctly New personnel supervised by experienced personnel alongside them	
29.8	Out of sequence		Same as Skip in the Pass the Sea Painter step (Item 28.2)		
29.9	As well as		No consequences of interest		
29.10	Other than/reverse (MSB incorrectly positioned)	Coxswain error Coxswain incorrectly directed by Safety/Deck supervisor	Hazardous exposure - contact injury when raising MSB (sway) Person overboard and/or equipment damage/loss (overboard) when raising MSB (sway) Equipment damage/loss (MSB) when raising MSB (sway)	Multiple people involved in the evolution who can notice that MSB not positioned correctly Frapping line tenders limit sway on MSB	
29.11	Caught in/on/by/between		No consequences of interest		

Table D.1B MSB WISE Worksheets (continued)

Item Number	Deviation	Causes	Consequences	Safeguards	Recommendations
29.0 STEP - POSITION THE MSB DIRECTLY UNDER THE FALL LINES (continued)					
29.12	Struck by/contact by	Boat crew error High seas	Hazardous exposure - contact injury: struck by blocks	New personnel supervised by experienced personnel alongside them  Boat crew wears hardhats	5
29.13	Contact with/struck against (hull of vessel)	More (too much power) (Item 29.6) More (too much rudder) (Item 29.7)	Equipment damage/loss (MSB)  Hazardous exposure - contact injury	New personnel supervised by experienced personnel alongside them  Boat crew specifically trained to hold on to monkey lines while MSB in the air or hooked to vessel	
29.14	Slip/trip/fall		No consequences of interest		
29.15	Stress/strain/fatigue		See general personnel fatigue issues		
29.16	Exposure to		See general personnel exposure issues		
29.17	Process upset/ malfunction		No consequences of interest		
29.18	Layout/traffic/siting		No consequences of interest		
29.19	Tools/equipment		No consequences of interest		

Table D.1B MSB WISE Worksheets (continued)

Item Number	Deviation	Causes	Consequences	Safeguards	Recommendations
30.0 STEP - MAN THE "MONKEY LINES"					
30.1	Missing	No missing steps identified			
30.2	Skip	Personnel in MSB do not support their weight on monkey lines - Same as Item 13.2 (skip) in the Man the MSB Monkey Lines step	Person overboard and/or equipment damage/loss (overboard) when raising MSB to the Rail step (Item 33.12)	Multiple people involved in the evolution who can notice that the boat crew is not holding on to monkey lines	
30.3	Part of	Same as Skip	No consequences of interest		
30.4	Less	No consequences of interest	No consequences of interest		
30.5	More	No consequences of interest	No consequences of interest		
30.6	Out of sequence	No consequences of interest	No consequences of interest		
30.7	As well as	No consequences of interest	No consequences of interest		
30.8	Other than/reverse	No consequences of interest	No consequences of interest		
30.9	Caught in/on/by/ between	No consequences of interest	No consequences of interest		
30.10	Struck by/contact by	No consequences of interest	No consequences of interest		
30.11	Contact with/struck against	No consequences of interest	No consequences of interest		

Table D.1B MSB WISE Worksheets (continued)

Item Number	Deviation	Causes	Consequences	Safeguards	Recommendations
30.0 STEP - MAN THE "MONKEY LINES" (continued)					
30.12	Slip/trip/fall		No consequences of interest		
30.13	Stress/strain/fatigue		See general personnel fatigue issues		
30.14	Exposure to		See general personnel exposure issues		
30.15	Process upset/malfunction		No consequences of interest		
30.16	Layout/traffic/siting		No consequences of interest		
30.17	Tools/equipment		No consequences of interest		
31.0 STEP - CONNECT FALL LINES TO THE MSB					
31.1	Missing		No missing steps identified		
31.2	Skip		No consequences of interest		
31.3	Part of		No consequences of interest		
31.4	Less		No consequences of interest		
31.5	More		No consequences of interest		

Table D.1B MSB WISE Worksheets (continued)

Item Number	Deviation	Causes	Consequences	Safeguards	Recommendations
31.0 STEP - CONNECT FALL LINES TO THE MSB (continued)					
31.6	Out of sequence (connect after fall line before forward fall line)	Boat crew error Coxswain error (orders wrong hookup sequence)	Equipment damage/loss when capsizing the MSB Entire step out of sequence, which is the same as Other than/reverse in the Position the MSB Directly Under the Fall Lines step (Item 29.10)	Safety/Deck supervisor monitors evolution Multiple personnel in the MSB and on deck make this event very unlikely	
31.7	As well as		No consequences of interest		
31.8	Other than/reverse		Same as Out of Sequence		
31.9	Caught in/on/by/between	Blocks too low (causing handling below deck line on MSB) High sea state	Hazardous exposure - contact injury: catch hands/fingers in block mechanism or between fall line and hull	No need to put hands in connection area to make connection (two handle grips on side of block connection)	
31.10	Struck by/contact by	High sea state Frapping line tenders do not control fall line tension - Same as Items 9.4 (Less) and 9.5 (More) in the Tend the MSB Frapping Lines step	Hazardous exposure - contact injury: struck by blocks	Boat crew wears hardhats Coxswain monitors evolution	5
31.11	Contact with/struck against		No consequences of interest		
31.12	Slip/trip/fall	Improper position of person grabbing block	Person overboard		Safety supervisor and deck supervisor monitor evolution
31.13	Stress/strain/fatigue		See general personnel fatigue issues		

Table D.1B MSB WISE Worksheets (continued)

Item Number	Deviation	Causes	Consequences	Safeguards	Recommendations
31.0 STEP - CONNECT FALL LINES TO THE MSB (continued)					
31.14	Exposure to		See general personnel exposure issues		
31.15	Process upset/ malfunction		No consequences of interest		
31.16	Layout/traffic/siting		No consequences of interest		
31.17	Tools/equipment		No consequences of interest		
32.0 STEP - STOP THE MSB ENGINE					
32.1	Missing		No missing steps identified		
32.2	Skip	Coxswain error	Equipment damage/loss: damage the MSB engine	Multiple people involved in the evolution make this event unlikely	
32.3	Part of		No consequences of interest		
32.4	Less		No consequences of interest		
32.5	More		No consequences of interest		
32.6	Out of sequence		No consequences of interest		



Table D.1B MSB WISE Worksheets (continued)

Item Number	Deviation	Causes	Consequences	Safeguards	Recommendations
32.0 STEP - STOP THE MSB ENGINE (continued)					
32.7	As well as		No consequences of interest		
32.8	Other than/reverse		No consequences of interest		
32.9	Caught in/on/by/ between		No consequences of interest		
32.10	Struck by/contact by		No consequences of interest		
32.11	Contact with/struck against		No consequences of interest		
32.12	Slip/trip/fall		No consequences of interest		
32.13	Stress/strain/fatigue		No consequences of interest		
32.14	Exposure to		No consequences of interest		
32.15	Process upset/ malfunction		No consequences of interest		
32.16	Layout/traffic/siting		No consequences of interest		
32.17	Tools/equipment		No consequences of interest		

Table D.1B MSB HISE Worksheets (continued)

Item Number	Deviation	Causes	Consequences	Safeguards	Recommendations
33.0 STEP - RAISE THE MSB TO THE RAIL					
33.1	Missing		No missing steps identified		
33.2	skip		No consequences of interest		
33.3	Part of		No consequences of interest		
33.4	Less	Hydraulic/winch operator suddenly stops raising MSB Deck supervisor orders sudden stop to raising MSB	Person overboard and/or equipment damage/loss: due to sudden stop or one/both fall line(s) break(s) due to sudden stop	Safety supervisor monitors evolution Proper launch course reduces chance of having to stop lowering suddenly Boat crew specifically trained to hold on to monkey lines while MSB in the air or hooked to vessel	
33.5	More		No consequences of interest		
33.6	Out of sequence		No consequences of interest		
33.7	As well as		No consequences of interest		
33.8	Other than/reverse	Deck supervisor misjudges timing of waves	Struck by/contact by - wave top (Item 33.10)		

Table D.1B MSB WISE Worksheets (continued)

Item Number	Deviation	Causes	Consequences	Safeguards	Recommendations
33.0 STEP - RAISE THE MSB TO THE RAIL (continued)					
33.9	Caught in/on/by/ between	Monkey lines mispositioned Personnel in MSB do not support their weight on monkey lines - Same as Item 13.2 (Skip) in the Man the MSB Monkey Lines step	Hazardous exposure - contact injury: boat crew caught in monkey line Equipment damage/loss: line caught on equipment (fire extinguisher, cleat, etc.) - capsize MSB	Safety and deck supervisors monitor the evolution Boat crew specifically trained to hold on to monkey lines while MSB in the air or hooked to vessel	
33.10	Struck by/contact by	Other than/reverse (misjudgment when raising MSB) (Item 33.8) High wave strikes MSB Frapping line tenders do not control sway of MSB - Same as Items 9.4 (Less) and 9.5 (More) in the Tend the MSB Frapping Lines step Improper launch course/speed (too much sway on MSB) - Same as Items 14.2 (Skip), 14.4/5 (Less), 14.6/7 (More) in the Establish Appropriate Launch Course step	Hazardous exposure - contact injury: hands/fingers caught between MSB and hull of vessel Hazardous exposure - contact injury Person overboard and/or equipment damage/loss (overboard) Equipment damage/loss: sway on MSB	Frapping line tenders limit sway of MSB Proper launch course reduces excessive sway when lowering Boat crew specifically trained to hold on to monkey lines Safety supervisor monitors evolution	
33.11	Contact with/struck against		No consequences of interest		
33.12	Slip/trip/fall	Skip in the Man the "Monkey Lines" step (Item 30.2)	Same as Struck by/contact by		
33.13	Stress/strain/fatigue		See general personnel fatigue issues		
33.14	Exposure to		See general personnel exposure issues		

Table D.1B MSB WISE Worksheets (continued)

Item Number	Deviation	Causes	Consequences	Safeguards	Recommendations
33.0 STEP - RAISE THE MSB TO THE RAIL (continued)					
33.15	Process upset/ malfunction		Same as Process upset/malfunction in the Lower the MSB step (see Item 16.15)		
33.16	Layout/traffic/siting		No consequences of interest		
33.17	Tools/equipment		No consequences of interest		
34.0 STEP - SNUG THE MSB AGAINST THE RAIL					
34.1	Missing		No missing steps identified		
34.2	Skip		No consequences of interest		
34.3	Part of		No consequences of interest		
34.4	Less (MSB loses grip on side of vessel)	Wet/icy conditions on side of vessel	Equipment damage/loss: damage to side of MSB	Deicing agents and ice removal practices	9
34.5	More (too fast)	Boom/winch operator moves MSB to the rail too fast  Deck supervisor accidentally orders MSB moved to the rail too fast	Person overboard in the Unload/Urman the MSB step (Item 35.12)	Contact with/struck against (Item 34.12)	Safety supervisor monitors evolution  Boat crew holds on to monkey lines

Table D.1B MSB WISE Worksheets (continued)

Item Number	Deviation	Causes	Consequences	Safeguards	Recommendations
34.0 STEP - SHUG THE MSB AGAINST THE RAIL (continued)					
34.6	More (too much canter)	Boom/winch operator places too much canter on MSB Deck supervisor accidentally orders too much canter on MSB	Person overboard and/or equipment damage/loss (overboard)	Safety supervisor monitors evolution Boat crew specifically trained to hold on to monkey lines while MSB in the air or hooked to vessel	
34.7	Out of sequence		No consequences of interest		
34.8	As well as		No consequences of interest		
34.9	Other than/reverse		No consequences of interest		
34.10	Caught in/on/by/between		No consequences of interest		
34.11	Struck by/contact by		No consequences of interest		
34.12	Contact with/struck against	More (too fast) (Item 34.5)	Equipment damage/loss: damage to the MSB Person overboard and/or equipment damage/loss (overboard)	Safety supervisor monitors evolution Boat crew specifically trained to hold on to monkey lines while MSB in the air or hooked to vessel	
34.13	Slip/trip/fall		No consequences of interest		
34.14	Stress/strain/fatigue		See general personnel fatigue issues		
34.15	Exposure to		See general personnel exposure issues		

Table D.1B MSB WISE Worksheets (continued)

Item Number	Deviation	Causes	Consequences	Safeguards	Recommendations
34.0 STEP - SHUG THE MSB AGAINST THE RAIL (continued)					
34.16	Process upset/ malfunction		No consequences of interest		
34.17	Layout/traffic/siting		No consequences of interest		
34.18	Tools/equipment		No consequences of interest		
35.0 STEP - UNLOAD/UNMAN THE MSB					
35.1	Missing		No missing steps identified		
35.2	Skip		No consequences of interest		
35.3	Part of		No consequences of interest		
35.4	Less		No consequences of interest		
35.5	More		No consequences of interest		
35.6	Out of sequence		Same as Slip/trip/fall (out of sequence with Snug the MSB Against the Rail step)		
35.7	As well as		No consequences of interest		

Table D.1B MSB WISE Worksheets (continued)

Item Number	Deviation	Causes	Consequences	Safeguards	Recommendations
35.0 STEP - UNLOAD/UNMAN THE MSB (continued)					
35.8	Other than/reverse		No consequences of interest		
35.9	Caught in/on/by/ between		No consequences of interest		
35.10	Struck by/contact by		No consequences of interest		
35.11	Contact with/struck against		No consequences of interest		
35.12	Slip/trip/fall	MSB loses grip on side of vessel (Less) in the Snug the MSB Against the Rail step (Item 34.4)  Personnel slip/trip/fall while unloading MSB due to high winds/seas/icy conditions	Person overboard and/or equipment damage/loss (overboard)	Safety and deck supervisors monitor evolution  Deicing agents and ice removal practices	9
35.13	Stress/strain/fatigue		See general personnel fatigue issues		
35.14	Exposure to		See general personnel exposure issues		
35.15	Process upset/malfunction		No consequences of interest		
35.16	Layout/traffic/siting		No consequences of interest		
35.17	Tools/equipment		No consequences of interest		

Table D.1B MSB WISE Worksheets (continued)

Item Number	Deviation	Causes	Consequences	Safeguards	Recommendations
36.0 STEP - RAISE THE MSB					
36.1	Missing		No missing steps identified		
36.2	Skip		No consequences of interest		
36.3	Part of		No consequences of interest		
36.4	Less		No consequences of interest		
36.5	More		No consequences of interest		
36.6	Out of sequence		Same as slip/trip/fall in the Unload/Urman the MSB step (Item 35.12)		
36.7	As well as		No consequences of interest		
36.8	Other than/reverse		No consequences of interest		
36.9	Caught in/on/by/ between		No consequences of interest		
36.10	Struck by/contact by		Same as Struck by/contact by in the Lower the MSB to the Rail step (see Item 10.10)		
36.11	Contact with/struck against		No consequences of interest		



Table D.1B MSB WISE Worksheets (continued)

Item Number	Deviation	Causes	Consequences	Safeguards	Recommendations
36.0 STEP - RAISE THE MSB (continued)					
36.12	slip/trip/fall		No consequences of interest		
36.13	Stress/strain/fatigue		See general personnel fatigue issues		
36.14	Exposure to		See general personnel exposure issues		
36.15	Process upset/ malfunction		Same as Process upset/malfunction in the Move the MSB Outboard step (see Item 8.15)		
36.16	Layout/traffic/siting		No consequences of interest		
36.17	Tools/equipment		No consequences of interest		
37.0 STEP - BRING THE MSB INBOARD					
37.1	Missing		No missing steps identified		
37.2	Skip		No consequences of interest		
37.3	Part of		No consequences of interest		
37.4	Less		No consequences of interest		

Table D.1B MSB WISE Worksheets (continued)

Item Number	Deviation	Causes	Consequences	Safeguards	Recommendations
<b>37.0 STEP - BRING THE MSB INBOARD (continued)</b>					
37.5	More (too fast)	Boom/winch operator brings in MSB too fast Deck supervisor orders MSB brought in too fast	Struck by/contact by (Item 37.10)		
37.6	Out of sequence		No consequences of interest		
37.7	As well as		No consequences of interest		
37.8	Other than/reverse (line tender error)	Frapping line tenders do not control sway of MSB - Same as Items 9.4 (Less) and 9.5 (More) in the Tend the MSB Frapping Lines step	Struck by/contact by (Item 37.10)		
37.9	Caught in/on/by/ between		No consequences of interest		
37.10	Struck by/contact by	Other than/reverse (line tender error) (Item 37.8) More (too fast) (Item 37.5) Process upset/malfunction (equipment failure) (Item 37.15) Process upset/malfunction (too much sway) (Item 37.16)	Hazardous exposure - contact injury Equipment damage/loss: damage to the MSB	Safety supervisor monitors evolution Deck supervisor directs boom/winch operator actions Deck personnel not positioned underneath MSB when moved in Frapping line tenders limit sway on MSB	MSB hydraulic system undergoes periodic preventive maintenance

Table D.1B MSB WISE Worksheets (continued)

Item Number	Deviation	Causes	Consequences	Safeguards	Recommendations
37.0 STEP - BRING THE MSB INBOARD (continued)					
37.11	Contact with/struck against		No consequences of interest		
37.12	Slip/trip/fall		No consequences of interest		
37.13	Stress/strain/fatigue		See general personnel fatigue issues		
37.14	Exposure to		See general personnel exposure issues		
37.15	Process upset/malfunction (equipment failure)	Hydraulic failure Fall line (support line) failure	Struck by/contact by (Item 37.10) Fire/explosion (hot engine catches fuel from fuel tank rupture on fire)		MSB hydraulic system undergoes periodic preventive maintenance Fall line failure considered unlikely since MSB not loaded at this point
37.16	Process upset/malfunction (too much sway)	Improper launch course/speed (too much sway on MSB) - Same as Items 14.2 (Skip), 14.4/5 (Less), 14.6/7 (More) in the Establish Appropriate Launch Course step	Struck by/contact by (Item 37.10)		
37.17	Layout/traffic/siting		No consequences of interest		
37.18	Tools/equipment		No consequences of interest		

Table D.18 MSB WISE Worksheets (continued)

Item Number	Deviation	Causes	Consequences	Safeguards	Recommendations
38.0 STEP - CRADLE THE MSB					
38.1	Missing		No missing steps identified		
38.2	Skip		No consequences of interest		
38.3	Part of		Same as Less		
38.4	Less (MSB not set in cradle)	Deck supervisor does not ensure MSB cradled properly	Caught in/on/by/between (Item 38.9)		
38.5	More		Same as More in the Bring the MSB Inboard step (see Item 37.5)		
38.6	Out of sequence		Same as Process upset/malfunction (equipment failure) in the Bring the MSB Inboard step (Item 37.15)		
38.7	As well as		No consequences of interest		
38.8	Other than/reverse	Frapping line tenders do not ensure that MSB shoes are in the down position Frapping line tenders do not control sway of MSB - Same as Items 9.4 (Less) and 9.5 (More) in the Tend the MSB Frapping Lines step	Struck by/contact by (Item 38.10) Equipment damage/loss: damage to shoes when MSB cradled	Safety supervisor and deck supervisor monitor evolution	

Table D.18 MSB WISE Worksheets (continued)

Item Number	Deviation	Causes	Consequences	Safeguards	Recommendations
38.0 STEP - CRADLE THE MSB (continued)					
38.9	Caught in/on/by/ between	Less (MSB not set in cradle) (Item 38.4) Deck personnel inattention	Hazardous exposure - contact injury: hands/fingers caught between MSB and cradle	Safety supervisor and deck supervisor monitor evolution	
38.10	Struck by/contact by	Other than/reverse (Item 38.8)	Same as Struck by/contact by in the Bring the MSB Inboard step (see Item 37.10)		
38.11	Contact with/struck against		No consequences of interest		
38.12	Slip/trip/fall		No consequences of interest		
38.13	Stress/strain/fatigue		See general personnel fatigue issues		
38.14	Exposure to		See general personnel exposure issues		
38.15	Process upset/ malfunction		Same as Process upset/malfunction in the Bring the MSB Inboard step (Item 37.15)		
38.16	Layout/traffic/siting		No consequences of interest		
38.17	Tools/equipment		No consequences of interest		

Table D.1B MSB WISE Worksheets (continued)

Item Number	Deviation	Causes	Consequences	Safeguards	Recommendations
39.0 STEP - SET THE SHOES					
39.1	Missing		No missing steps identified		
39.2	Skip (deck crew does not set shoes)	Deck crew distracted and does not set MSB shoes	Caught in/on/by/between (Item 39.9)		
39.3	Part of (only set one shoe)	Deck crew distracted and sets only one MSB shoe	Caught in/on/by/between (Item 39.9)		
39.4	Less		Same as Part of		
39.5	More		No consequences of interest		
39.6	Out of sequence	Deck crew gets in a rush and prematurely sets shoes before MSB cradled	Equipment damage/loss: damage MSB and/or shoes	Safety and deck supervisor monitor the evolution	
39.7	As well as		No consequences of interest		
39.8	Other than/reverse		No consequences of interest		
39.9	Caught in/on/by/between	Skip (Item 39.2) Part of (Item 39.3)	Hazardous exposure - contact injury: hands/fingers caught between MSB and cradle Equipment damage/loss: damage to MSB if it rolls in cradle	Safety supervisor and deck supervisor monitor evolution	
39.10	Struck by/contact by		No consequences of interest		

Table D.1B MSB WISE Worksheets (continued)

Item Number	Deviation	Causes	Consequences	Safeguards	Recommendations
39.0 STEP - SET THE SHOES (continued)					
39.11	Contact with/struck against		No consequences of interest		
39.12	Slip/trip/fall		No consequences of interest		
39.13	Stress/strain/fatigue		See general personnel fatigue issues		
39.14	Exposure to		See general personnel exposure issues		
39.15	Process upset/malfunction		No consequences of interest		
39.16	Layout/traffic/siting		No consequences of interest		
39.17	Tools/equipment		No consequences of interest		
40.0 STEP - SET THE PINS					
40.1	Missing		Same as Skip and Part of (this step missing from current deck procedure)		11
40.2	Skip (deck crew does not set pins)	Deck crew distracted and does not set pins in place	Equipment damage/loss: damage MSB if it rolls in cradle or hydraulics inadvertently actuated	Safety supervisor and deck supervisor monitor evolution	

Table D.1B MSB WISE Worksheets (continued)

Item Number	Deviation	Causes	Consequences	Safeguards	Recommendations
40.0 STEP - SET THE PINS (continued)					
40.3	Part of (only set one pin in place)	Deck crew distracted and does not set one of the pins in place	Equipment damage/loss; damage MSB if it rolls in cradle or hydraulics inadvertently actuated	Safety supervisor and deck supervisor monitor evolution	
40.4	Less		Same as Part of		
40.5	More		No consequences of interest		
40.6	Out of sequence		No consequences of interest		
40.7	As well as		No consequences of interest		
40.8	Other than/reverse		No consequences of interest		
40.9	Caught in/on/by/between		No consequences of interest		
40.10	Struck by/contact by		No consequences of interest		
40.11	Contact with/struck against		No consequences of interest		
40.12	Slip/trip/fall		No consequences of interest		
40.13	Stress/strain/fatigue		See general personnel fatigue issues		



Table D.1B MSB WISE Worksheets (continued)

Item Number	Deviation	Causes	Consequences	Safeguards	Recommendations
40.0 STEP - SET THE PINS (continued)					
40.14	Exposure to		See general personnel exposure issues		
40.15	Process upset/ malfunction		No consequences of interest		
40.16	Layout/traffic/siting		No consequences of interest		
40.17	Tools/equipment		No consequences of interest		
41.0 STEP - GRIPE THE BOAT					
41.1	Missing		No missing steps identified		
41.2	Skip	Deck crew distracted and does not gripe the boat	Equipment damage/loss: damage MSB if it rolls in cradle		Involvement of multiple people on the deck makes failure to gripe small boat unlikely
41.3	Part of		No consequences of interest		
41.4	Less		No consequences of interest		
41.5	More		No consequences of interest		
41.6	Out of sequence		No consequences of interest		

Table D.1B MSB WISE Worksheets (continued)

Item Number	Deviation	Causes	Consequences	Safeguards	Recommendations
41.0 STEP - GRIPE THE BOAT (continued)					
41.7	As well as		No consequences of interest		
41.8	Other than/reverse		No consequences of interest		
41.9	Caught in/on/by/ between		No consequences of interest		
41.10	Struck by/contact by		No consequences of interest		
41.11	Contact with/struck against		No consequences of interest		
41.12	Slip/trip/fall	Personnel on top of MSB lose balance Wet/icy conditions on top of MSB	Person overboard Hazardous exposure - contact injury: fall on deck	New personnel have experienced personnel alongside them Safety supervisor and deck supervisor monitor evolution Deicing agents and ice removal practices	
41.13	Stress/strain/fatigue		See general personnel fatigue issues		
41.14	Exposure to		See general personnel exposure issues		
41.15	Process upset/ malfunction		No consequences of interest		
41.16	Layout/traffic/siting		No consequences of interest		

Table D.1B MSB WISE Worksheets (continued)

Item Number	Deviation	Causes	Consequences	Safeguards	Recommendations
41.0 STEP - GRIPE THE BOAT (continued)					
41.17	Tools/equipment		No consequences of interest		
42.0 STEP - SECURE AND STORE ALL GEAR					
42.1	Missing		No missing steps identified		
42.2	Skipped	Deck crew rushed to get inside	Equipment damage/loss (overboard)		Involvement of multiple people on the deck makes failure to leave equipment on deck unlikely
42.3	Part of	Deck crew rushed to get inside	Equipment damage/loss (overboard)		Involvement of multiple people on the deck makes failure to leave equipment on deck unlikely
42.4	Less		Same as Part of		
42.5	More		No consequences of interest		
42.6	Out of sequence		No consequences of interest		
42.7	As well as		No consequences of interest		
42.8	Other than/reverse		No consequences of interest		
42.9	Caught in/on/by/between		No consequences of interest		

Table D.1B MSB WISE Worksheets (continued)

Item Number	Deviation	Causes	Consequences	Safeguards	Recommendations
42.0 STEP - SECURE AND STORE ALL GEAR (continued)					
42.10	Struck by/contact by		No consequences of interest		
42.11	Contact with/struck against		No consequences of interest		
42.12	Slip/trip/fall		Same as Slip/trip/fall in the Man the MSB Launch Stations step (see Item 4.12)		
42.13	Stress/strain/fatigue		See general personnel fatigue issues		
42.14	Exposure to		See general personnel exposure issues		
42.15	Process upset/malfunction		No consequences of interest		
42.16	Layout/traffic/siting		No consequences of interest		
42.17	Tools/equipment		No consequences of interest		

**Table D.2B Consequences (Mishaps of Interest)**

<b>Mishap of Interest</b>	
Capsizing vessel	Drowning
Collision with another vessel	Person overboard
Collision with a fixed object	Hazardous exposure: contact injury
Collision with a floating object	Hazardous exposure: toxic/corrosive materials
Collision with helo	Hazardous exposure: electrical shock
Grounding vessel	Hazardous exposure: cold environment/surface/material
Sinking vessel	Hazardous exposure: hot environment/surface/material
Fouled screw	Hazardous exposure: asphyxiants
Fire/explosion	Hazardous exposure: noise
Firearm discharge	Hazardous exposure: radiation
Equipment damage/loss	Hazardous exposure: biological materials
Loss of small boat	
Loss of helo	

**Table D.3B General Personnel Issues Relating to Fatigue**

**Fatigue** — All vessel crew members are subject to certain levels of fatigue while performing duties at sea. This can impact a person's ability to assess and respond to situations at all phases in evolutions.

<b>Generic Factors Affecting Fatigue</b>	<b>Generic Safeguards Against Fatigue</b>
<ul style="list-style-type: none"> <li>• Vessel crew understaffed for current missions</li> <li>• Low amounts of sleep</li> <li>• One or more events during operations requiring long, prolonged concentration</li> <li>• Inclement weather</li> <li>• Inadequate nutrition</li> <li>• Inadequate shipboard cleanliness</li> </ul>	<ul style="list-style-type: none"> <li>• Physical fitness standards</li> <li>• Command assessment of crew capability to respond to missions (also accounting for weather conditions)</li> <li>• Multiple personnel involved in operations decision making</li> <li>• Safety supervisors present during deck evolutions</li> <li>• Vessel health standards (including the galley)</li> <li>• Four meals served a day</li> </ul>

**Table D.4B General Personnel Issues Relating to Exposure**

**Exposure** — Both cold and hot weather conditions can severely impact vessel operations, especially for deck personnel. Inadequate protection from the weather elements can lower personnel performance and severely impact the health of crew members.

Generic Factors Affecting Exposure	Generic Safeguards Against Exposure
<ul style="list-style-type: none"> <li>• Inaccurate assessment of weather conditions</li> <li>• Personnel/supervisory inattention to individual exposure protection requirements</li> <li>• Supervisory inattention to longer duration or intense short duration exposure conditions</li> <li>• Insufficient amounts of exposure protection equipment onboard</li> <li>• Degradation of exposure protection equipment</li> </ul>	<ul style="list-style-type: none"> <li>• Multiple personnel involved in operations decision making</li> <li>• New personnel supervised by experienced personnel and by safety supervisors</li> <li>• Standard amounts of exposure protection equipment required to be carried onboard</li> <li>• Exposure equipment for deck personnel inspected by Deck Division on a periodic basis</li> </ul>

***ATTACHMENT C***

***Rigid Hull Inflatable Boat (RHI) WISE Worksheets***

The proceedings of the WISE review were recorded in Table D.1C using computer software specially designed for this purpose. The table is composed of six columns: **Item Number**, **Deviation**, **Causes**, **Consequences**, **Safeguards**, and **Recommendations**. This table is similar to that used in the preliminary hazard analysis (coarse hazard analysis) task (SOW Task 4.3.a).

The first column, **Item Number**, represents a distinct action item step in the launch/recovery evolution. The launch/recovery procedure was broken down into distinct steps so that each step could be evaluated in detail.

The second column, **Deviation**, is defined as an upset from normal operations. The WISE technique uses a set of guide words to facilitate evaluation of potential upset conditions/situations. Table D.7 lists the guide words along with descriptions of their meanings. Although the guide words were developed for application within the petroleum and chemical processing industries, they are still applicable to USCG operations.

Causes of each deviation are listed in the third column of the worksheet. Generally, only functional failures, human errors, single equipment failures, or external conditions (winds, seas) were considered because these typically are the most significant causes of deviations.

The **Consequences** column identifies the mishaps of interest associated with a particular deviation. Mishaps of interest were identified in the coarse hazard analysis project. The mishap titles are similar to those found in the MISREP database. Table D.2C lists mishaps of interest for this study. If the team found no applicable mishaps or no mishaps at all stemming from a deviation, "No consequences of Interest" was entered into the table. The one exception was in the "Missing" deviation, in which "No missing steps identified" was entered.

**Safeguards** (column 5) are equipment features, procedural steps, or operator actions intended to (1) reduce the likelihood of one or more causes producing consequences or (2) reduce the severity of the given consequences. Training safeguards were listed if crew members are specifically trained on a preventive/protective action. Also, certain safeguards applicable to a wide range of steps, such as the Safety Supervisor monitoring the evolution, were included to show the safeguard's area of coverage.

The last column in the worksheet, **Recommendations**, refers to specific suggestions that are described as recommendations in the report. The suggestions were developed based on analysis team discussions and include hardware additions, procedural upgrades, documentation reviews, and policy/guidance changes. These recommendations are strictly the suggestions of the analysis team. Past USCG studies may already address the identified risks. There may also exist more effective ways for protecting against hazards, and some recommendations may not be practical or cost effective.



Fatigue and external weather exposure issues were considered applicable to most steps in the launch/recovery procedure and were not specifically evaluated in each Item Number step. Table D.3C and Table D.4C list general causes and safeguards for fatigue and exposure respectively.

Table D.1C RHI Wise Worksheets

Item Number	Deviation	Causes	Consequences	Safeguards	Recommendations
<b>1.0 STEP - PERFORM SMALL BOAT CHECKS BEFORE OPERATIONS BEGIN</b>					
1.1	Missing		No missing steps identified		
1.2	Skip	Engineering or operations fails to perform required checks of liquid levels, electrical systems, engine status, and boat equipment  Engineering or operations requirements for checking small boats temporarily suspended because personnel are directed to other tasks	Potential for defective or removed safety features aboard the RHI to be unavailable when needed	OOD verifies that required engineering checks are performed by receiving/reviewing daily engineering small boat check sheet  Deck Division LPO verifies that required deck-related small boat checks are performed by receiving/reviewing daily deck small boat checks	3
1.3	Part of		Same as Skip		
1.4	Less		Same as Skip		
1.5	More		No consequences of interest		
1.6	Out of sequence		No consequences of interest		
1.7	As well as		No consequences of interest		
1.8	Other than/reverse		Same as Skip		
1.9	Caught in/on/by/ between		No consequences of interest		
1.10	Struck by/contact by		No consequences of interest		

Table D.1C RHI Wise Worksheets (continued)

Item Number	Deviation	Causes	Consequences	Safeguards	Recommendations
1.0 STEP - PERFORM SMALL BOAT CHECKS BEFORE OPERATIONS BEGIN (continued)					
1.11	Contact with/struck against		No consequences of interest		
1.12	Slip/trip/fall	Personnel fall from the RHI, especially in wet/icy weather and/or heavy winds/seas	Hazardous exposure - contact injury	Deicing agents and ice removal practices	
1.13	Stress/strain/fatigue		No consequences of interest		
1.14	Exposure to		No consequences of interest		
1.15	Process upset/malfunction		No consequences of interest		
1.16	Layout/traffic/siting		No consequences of interest		
1.17	Tools/equipment		No consequences of interest		

Table D.1C RHI Wise Worksheets (continued)

Item Number	Deviation	Causes	Consequences	Safeguards	Recommendations
2.0 STEP - DECIDE TO LAUNCH A SMALL BOAT					
2.1	Missing	No missing steps identified			
2.2	Skip	Operations initiates small boat launch without appropriate approval (or misunderstands direction/delegation of authority) from the commanding officer or the executive officer	Potential for small boat mishap that could result in equipment damage/loss (RHI) and/or a person overboard if operations fails to detect that conditions are unsafe for RHI launching/recovery	Chain of command authority Involvement of multiple personnel on the bridge and the deck makes failure to obtain appropriate approvals very unlikely	1
2.3	Part of	Operations initiates small boat launch without appropriate evolution-related inputs from the bridge and deck personnel	Potential for small boat mishap that could result in equipment damage/loss (RHI) and/or a person overboard if operations fails to detect that conditions are unsafe for RHI launching/recovery	Chain of command authority Involvement of multiple personnel on the bridge and the deck makes failure to obtain appropriate evolution-related inputs very unlikely	
2.4	Less		Same as Part of		
2.5	More		No consequences of interest		
2.6	Out of sequence		No consequences of interest		
2.7	As well as		No consequences of interest		

Table D.1C RHI Wise Worksheets (continued)

Item Number	Deviation	Causes	Consequences	Safeguards	Recommendations
2.0 STEP - DECIDE TO LAUNCH A SMALL BOAT (continued)					
2.8	Other than/reverse (wrong decision)	<p>Available weather/sea data are unreliable</p> <p>Crew fails to appropriately assess the significance of available weather/sea data</p> <p>Available vessel/crew status reports are unreliable</p> <p>Crew fails to appropriately assess the significance of available vessel/crew status reports</p> <p>Crew excessively weights urgency of mission in comparison with other decision factors</p> <p>Crew fails to consider how quickly weather, sea, vessel, or crew conditions may change</p>	<p>Potential for small boat mishap that could result in equipment damage/loss (RHI) and/or a person overboard if the crew fails to detect that conditions are unsafe for RHI launching/recovery</p>	<p>Involvement of multiple personnel on the bridge and the deck makes failure to appropriately assess situation unlikely (unless the situation is very dynamic and the need to launch is urgent)</p>	1
2.9	Caught in/on/by/between		No consequences of interest		
2.10	Struck by/contact by		No consequences of interest		
2.11	Contact with/struck against		No consequences of interest		
2.12	Slip/trip/fall		No consequences of interest		
2.13	Stress/strain/fatigue		See general personnel fatigue issues		

Table D.1C RHI Wise Worksheets (continued)

Item Number	Deviation	Causes	Consequences	Safeguards	Recommendations
2.0 STEP - DECIDE TO LAUNCH A SMALL BOAT (continued)					
2.14	Exposure to		No consequences of interest		
2.15	Process upset/ malfunction		No consequences of interest		
2.16	Layout/traffic/siting		No consequences of interest		
2.17	Tools/equipment		No consequences of interest		
3.0 STEP - DECIDE TO USE THE RHI INSTEAD OF THE MSB					
3.1	Missing		No missing steps identified		
3.2	Skip	Operations initiates RHI launch without appropriate approval (or misunderstands direction/delegation of authority) from the commanding officer or the executive officer	Potential for small boat mishap that could result in equipment damage/loss (RHI) and/or a person overboard if operations fails to detect that conditions are unsafe for RHI launching/recovery	Chain of command authority Involvement of multiple personnel on the bridge and the deck makes failure to select appropriate small boat very unlikely	2
3.3	Part of		No consequences of interest		
3.4	Less		No consequences of interest		
3.5	More		No consequences of interest		

Table D.1C RHI Wise Worksheets (continued)

Item Number	Deviation	Causes	Consequences	Safeguards	Recommendations
3.0 STEP - DECIDE TO USE THE RHI INSTEAD OF THE MSB (continued)					
3.6	Out of sequence	Same as Skip in the Decide to Launch a Small Boat step (Item 2.2)	Same as Skip in the Decide to Launch a Small Boat step (Item 2.2)		
3.7	As well as	No consequences of interest	No consequences of interest		
3.8	Other than/reverse (wrong decision on which small boat to use)	Operations fails to adequately assess mission conditions and sends RHI instead of MSB (RHI not as stable in rougher seas and cannot carry as much cargo as MSB)	Potential for small boat mishap that could result in equipment damage/loss (RHI) and/or a person overboard if operations fails to detect that conditions are unsafe for the RHI	Involvement of multiple personnel on the bridge and the deck makes failure to appropriately assess situation unlikely (unless the situation is very dynamic and the need to launch is urgent)	2
3.9	Caught in/on/by/ between	No consequences of interest	No consequences of interest		
3.10	Struck by/contact by	No consequences of interest	No consequences of interest		
3.11	Contact with/struck against	No consequences of interest	No consequences of interest		
3.12	Slip/trip/fall	No consequences of interest	No consequences of interest		
3.13	Stress/strain/fatigue	See general personnel fatigue issues	See general personnel fatigue issues		
3.14	Exposure to	No consequences of interest	No consequences of interest		
3.15	Process upset/ malfunction	No consequences of interest	No consequences of interest		

Table D.1C RHI Wise Worksheets (continued)

Item Number	Deviation	Causes	Consequences	Safeguards	Recommendations
3.0 STEP - DECIDE TO USE THE RHI INSTEAD OF THE MSB (continued)					
3.16	Layout/traffic/siting		No consequences of interest		
3.17	Tools/equipment		No consequences of interest		
4.0 STEP - MAN THE RHI LAUNCH STATIONS					
4.1	Missing		No missing steps identified		
4.2	Skip		No consequences of interest		
4.3	Part of	Required personnel involved in other duties Required personnel not onboard Not all required personnel heard the IMC (intercom) announcement	Potential for small boat mishap that could result in equipment damage/loss (RHI) and/or a person overboard if not all deck evolution personnel (safety and operators) present	Multiple people involved in the deck evolution can notice that not all required personnel are present  Deck supervisor required to report Manned and Ready to the bridge when all required personnel are present  Other crew members available to support the evolution if needed	
4.4	Less		Same as Part of		
4.5	More		No consequences of interest		
4.6	Out of sequence		No consequences of interest		



Table D.1C RHI Wise Worksheets (continued)

Item Number	Deviation	Causes	Consequences	Safeguards	Recommendations
4.0 STEP - MAN THE RHI LAUNCH STATIONS (continued)					
4.7	As well as		No consequences of interest		
4.8	Other than/reverse	Wrong or unqualified personnel inadvertently called in to fill key small boat launch positions New personnel mistakenly show up for the evolution	Potential for small boat mishap that could result in equipment damage/loss (RHI) and/or a person overboard if wrong/unqualified personnel present in key positions	Deck and safety supervisors check that appropriate personnel are in place All deck personnel advised to speak up if they notice potential safety hazards	
4.9	Caught in/on/by/ between		No consequences of interest		
4.10	Struck by/contact by		No consequences of interest		
4.11	Contact with/struck against		No consequences of interest		
4.12	Slip/trip/fall	Deck personnel slip or fall when manning their stations, especially in wet/icy conditions and/or in heavy winds/seas	Hazardous exposure - contact injury Person overboard and/or equipment damage/loss (overboard)	New personnel supervised by experienced personnel alongside them and by supervisors (actions are observed, new personnel told not to rush, etc.) Deicing agents and ice removal practices	
4.13	Stress/strain/fatigue		See general personnel fatigue issues		
4.14	Exposure to		See general personnel exposure issues		

Table D.1C RHI Wise Worksheets (continued)

Item Number	Deviation	Causes	Consequences	Safeguards	Recommendations
4.0 STEP - MAN THE RHI LAUNCH STATIONS (continued)					
4.15	Process upset/ malfunction		No consequences of interest		
4.16	Layout/traffic/siting		No consequences of interest		
4.17	Tools/equipment		No consequences of interest		
5.0 STEP - UNGRIPE THE RHI					
5.1	Missing		No missing steps identified		
5.2	Skip	Deck crew distracted and does not ungrripe RHI	Struck by/contact by (Item 5.10) Equipment damage/loss: potential to damage crane hydraulics when moving RHI Equipment damage/loss: damage gripping straps when moving RHI		Involvement of multiple people on deck makes failure to ungrripe small boat unlikely
5.3	Part of		Same as Skip		
5.4	Less		Same as Skip		
5.5	More		No consequences of interest		
5.6	Out of sequence		No consequences of interest		

Table D.1C RHI Wise Worksheets (continued)

Item Number	Deviation	Causes	Consequences	Safeguards	Recommendations
5.0 STEP - UNGRIPE THE RHI (continued)					
5.7	As well as		No consequences of interest		
5.8	Other than/reverse		Same as Skip		
5.9	Caught in/on/by/ between		No consequences of interest		
5.10	Struck by/contact by	Skip (gripe straps left in place) (Item 5.2)	Hazardous exposure - contact injury: gripe straps snap	Involvement of multiple people on deck makes failure to ungrripe small boat unlikely	
5.11	Contact with/struck against		No consequences of interest		
5.12	Slip/trip/fall		No consequences of interest		
5.13	Stress/strain/fatigue		See general personnel fatigue issues		
5.14	Exposure to		See general personnel exposure issues		
5.15	Process upset/ malfunction		No consequences of interest		
5.16	Layout/traffic/siting		No consequences of interest		
5.17	Tools/equipment		No consequences of interest		

Table D.1C RHI Wise Worksheets (continued)

Item Number	Deviation	Causes	Consequences	Safeguards	Recommendations
6.0 STEP - HOOK BOOM CABLE TO METAL RING					
6.1	Missing		Although no consequences of interest, this step missing from the RHI procedure		13
6.2	Skip		No consequences of interest		
6.3	Part of (boom cable not completely hooked up)	Deck crewman does not completely hook boom cable to metal ring	Struck by/contact by (Item 6.10)		
6.4	Less		Same as Part of		
6.5	More		No consequences of interest		
6.6	Out of sequence		No consequences of interest		
6.7	As well as		No consequences of interest		
6.8	Other than/reverse		Same as Part of		
6.9	Caught in/on/by/between		No consequences of interest		

Table D.1C RHI Wise Worksheets (continued)

Item Number	Deviation	Causes	Consequences	Safeguards	Recommendations
6.0 STEP - HOOK BOOM CABLE TO METAL RING (continued)					
6.10	Struck by/contact by	Part of (boom cable not completely hooked up) (Item 6.3)	Hazardous exposure - contact injury when RHI drops in the Raise RHI onto the J-Hooks step (Item 7)	Safety/deck supervisor monitors evolution	
			Equipment damage/loss when RHI drops in the Raise RHI onto the J-Hooks step (Item 7)	New personnel supervised by experienced personnel alongside them	
6.11	Contact with/struck against		No consequences of interest		
6.12	Slip/trip/fall	Deck crewman falls off RHI when hooking up the boom cable due to wet/icy conditions or high winds/sea	Hazardous exposure - contact injury	Safety/deck supervisor monitors evolution	New personnel supervised by experienced personnel alongside them
6.13	Stress/strain/fatigue		See general personnel fatigue issues		Deicing agents and ice removal practices
6.14	Exposure to		See general personnel exposure issues		
6.15	Process upset/malfunction		No consequences of interest		
6.16	Layout/traffic/siting		No consequences of interest		
6.17	Tools/equipment		No consequences of interest		

Table D.1C RHI Wise Worksheets (continued)

Item Number	Deviation	Causes	Consequences	Safeguards	Recommendations
<b>7.0 STEP - RAISE RHI ONTO J-HOOKS</b>					
7.1	Missing	No missing steps identified			
7.2	Skip (RHI not raised onto J-Hooks)	Deck crew distracted or in a rush J-Hooks not attached to articulating crane for maintenance reasons	Hazardous exposure - contact injury: RHI sways excessively when being swung over the water Equipment damage/loss: RHI damaged due to excessive sway when being swung over the water	Safety/deck supervisor monitors evolution If J-hooks not attached to articulating crane, extra frapping lines can be attached	
7.3	Part of (RHI not fully secure in J-Hooks)	RHI not fully raised into J-Hooks	Equipment damage/loss as RHI strikes against the on J-hooks when being swung over the water	Safety/deck supervisor monitors Frapping line tenders control sway on RHI	
7.4	Less		Same as Part of		
7.5	More (RHI raised too far into J-Hooks)	Articulating crane operator raises RHI too far into J-hooks Deck supervisor directs crane operator to continue raising RHI into J-Hooks	Struck by/contact by (Item 7.10)		
7.6	Out of sequence		Same as Skip in the Ungripe the RHI step (Item 5.2)		
7.7	As well as		No consequences of interest		
7.8	Other than/reverse		Same as More and Part of		

Table D.1C RHI Wise Worksheets (continued)

Item Number	Deviation	Causes	Consequences	Safeguards	Recommendations
7.0 STEP - RAISE RHI ONTO J-HOOKS (continued)					
7.9	Caught in/on/by/ between		No consequences of interest		
7.10	Struck by/contact by	More (RHI raised too far into J-Hooks) (Item 7.5)	Hazardous exposure - contact injury: RHI drops if boom breaks free from metal ring Equipment damage/loss: RHI or raising straps damaged	Safety supervisor monitors evolution	
7.11	Contact with/struck against		No consequences of interest		
7.12	Slip/trip/fall		No consequences of interest		
7.13	Stress/strain/fatigue		See general personnel fatigue issues		
7.14	Exposure to		See general personnel exposure issues		
7.15	Process upset/ malfunction		No consequences of interest		
7.16	Layout/traffic/siting		No consequences of interest		
7.17	Tools/equipment		No consequences of interest		

Table D.1C RHI Wise Worksheets (continued)

Item Number	Deviation	Causes	Consequences	Safeguards	Recommendations
8.0 STEP - SWING RHI OVER THE WATER					
8.1	Missing		No missing steps identified		
8.2	Skip		No consequences of interest		
8.3	Part of		Same as Less		
8.4	Less (RHI not moved out enough)	Deck supervisor misjudges distance RHI moved out	RHI damaged when lowered to the rail	Involvement of multiple people on the deck makes lowering RHI onto rail extremely unlikely	4
8.5	More (move RHI out too fast)	Deck supervisor orders RHI swung out too fast Articulating crane operator accidentally moves RHI out too fast	Struck by/contact by (Item 8.10)		
8.6	Out of sequence		Same as Skip in steps Ungripe the RHI (Item 5.2) and Raise RHI Onto J-Hooks (Item 7.2)		
8.7	As well as		No consequences of interest		
8.8	Other than/reverse (no control of RHI sway)	Frapping (line tenders do not control sway of RHI - Same as Items 10.4 (Less) and 10.5 (More) in the Tend RHI Frapping Lines step	Struck by/contact by (Item 8.10)		
8.9	Caught in/on/by/between		No consequences of interest		



Table D.1C RHI Wise Worksheets (continued)

Item Number	Deviation	Causes	Consequences	Safeguards	Recommendations
8.0 STEP - SWING RHI OVER THE WATER (continued)					
8.10	Struck by/contact by	More (move RHI out too fast) (Item 8.5) Process upset/malfunction (equipment failure) (Item 8.15) Other than/reverse (no control of RHI sway) (Item 8.8) Process upset/malfunction (too much sway due to vessel course/speed) (Item 8.16)	Hazardous exposure - contact injury Equipment damage/loss to RHI	Safety supervisor monitors evolution Deck supervisor controls actions of articulating crane operator Frapping line tenders control sway of RHI Deck personnel not positioned under RHI when swung over the water RHI hydraulics system undergoes periodic preventive maintenance Safety supervisor can communicate with the bridge if vessel course/speed places too much sway on RHI	
8.11	Contact with/struck against		No consequences of interest		
8.12	Slip/trip/fall		No consequences of interest		
8.13	Stress/strain/fatigue		See general personnel fatigue issues		
8.14	Exposure to		See general personnel exposure issues		
8.15	Process upset/malfunction	Hydraulic failure (drop RHI) Fall line (support line) failure	Struck by/contact by (Item 8.10)	Fall line failure considered unlikely since any support failures expected when Raising RHI into the J-hooks RHI launch equipment inspected periodically	

Table D.1C RHI Wise Worksheets (continued)

Item Number	Deviation	Causes	Consequences	Safeguards	Recommendations
8.0 STEP - SWING RHI OVER THE WATER (continued)					
8.16	Process upset/ malfunction (too much sway due to vessel course/speed)	Improper launch course/speed - Same as Items 15.2 (Skip), 15.4 (Less), 15.6/7 (More) in Establish Appropriate Launch Course step	Struck by/contact by (Item 8.10)		
8.17	Layout/traffic/siting		No consequences of interest		
8.18	Tools/equipment		No consequences of interest		
9.0 STEP - TEND THE SEA PAINTER					
9.1	Missing		No missing steps identified		
9.2	Skip		Same as Less		
9.3	Part of		Same as Skip		
9.4	Less (too much slack in sea painter)	Sea painter tender distracted and does not tend sea painter	Struck by/contact by (Item 9.10)		
9.5	More (too much tension on sea painter)	Sea painter tender places too much tension on sea painter as RHI swings over the water	Struck by/contact by (Item 9.10)		
9.6	Out of sequence		No consequences of interest		
9.7	As well as		No consequences of interest		

Table D.1C RHI Wise Worksheets (continued)

Item Number	Deviation	Causes	Consequences	Safeguards	Recommendations
9.0 STEP - TEND THE SEA PAINTER (continued)					
9.8	Other than/reverse		Same as More and skip		
9.9	Caught in/on/by/ between		No consequences of interest		
9.10	Struck by/contact by	More (Item 9.5) Less (Item 9.4)	Hazardous exposure - contact injury: sea painter catches deck crewmen as RHI swings over water  Hazardous exposure - contact injury due to RHI sway	Safety/deck supervisor monitors evolution  New personnel supervised by experienced personnel alongside them	
9.11	Contact with/struck against		No consequences of interest		
9.12	Slip/trip/fall		No consequences of interest		
9.13	Stress/strain/fatigue		See general personnel fatigue issues		
9.14	Exposure to		See general personnel exposure issues		
9.15	Process upset/ malfunction		No consequences of interest		
9.16	Layout/traffic/siting		No consequences of interest		
9.17	Tools/equipment		No consequences of interest		

Table D.1c RHI Wise Worksheets (continued)

Item Number	Deviation	Causes	Consequences	Safeguards	Recommendations
10.0 STEP - TEND RHI FRAPPING LINES					
10.1	Missing		No missing steps identified		
10.2	Skip		Same as Less		
10.3	Part of		Same as Less		
10.4	Less (too much slack in frapping lines)	Frapping line tenders allow too much slack in frapping lines Deck supervisor orders too much slack in frapping lines	Struck by/contact by (Item 10.10)		
10.5	More (too much tension on frapping lines)	Frapping line tenders place too much tension on frapping lines Deck supervisor orders too much tension on frapping lines	Struck by/contact by - RHI swaying if frapping lines(s) break or if RHI swings into vessel suddenly when drawn in by frapping line tenders (Item 10.10) Process upset/malfunction (frapping lines break) (Item 10.15)		
10.6	Out of sequence		No consequences of interest		
10.7	As well as		No consequences of interest		
10.8	Other than/reverse		No consequences of interest		
10.9	Caught in/on/by/between		No consequences of interest		

Table D.1C RHI Wise Worksheets (continued)

Item Number	Deviation	Causes	Consequences	Safeguards	Recommendations
10.0 STEP - TEND RHI FRAPPING LINES (continued)					
10.10	Struck by/contact by	Less (too much slack in frapping lines) (Item 10.4) More (too much line tension) (Item 10.5) Process upset/malfunction (frapping lines break) (Item 10.15)	Hazardous exposure - contact injury Equipment damage/loss to RHI	Safety supervisor monitors evolution Deck personnel not positioned under RHI when swung over the water RHI launch equipment periodically inspected	
10.11	Contact with/struck against		No consequences of interest		
10.12	Slip/trip/fall		No consequences of interest		
10.13	Stress/strain/fatigue		See general personnel fatigue issues		
10.14	Exposure to		See general personnel exposure issues		
10.15	Process upset/malfunction	More (too much tension on frapping lines) (Item 10.5) Frapping line defect	Struck by/contact by (Item 10.10)		
10.16	Layout/traffic/siting		No consequences of interest		
10.17	Tools/equipment		No consequences of interest		

Table D.1C RHI Wise Worksheets (continued)

Item Number	Deviation	Causes	Consequences	Safeguards	Recommendations
11.0 STEP - EXTEND BOOM OVER THE WATER					
11.1	Missing		No missing steps identified		
11.2	Skip		Same as Less		
11.3	Part of		Same as Less		
11.4	Less	Deck supervisor does not order boom extended out enough Articulating crane operator does not extend boom out enough	Equipment damage/loss when RHI lowered onto rail	Safety supervisor monitors evolution Multiple people involved in evolution make this unlikely	
11.5	More		No consequences of interest		
11.6	Out of sequence		No consequences of interest		
11.7	As well as		No consequences of interest		
11.8	Other than/reverse		Same as Less		
11.9	Caught in/on/by/between		No consequences of interest		
11.10	Struck by/contact by		No consequences of interest		
11.11	Contact with/struck against		No consequences of interest		

Table D.1C RHI Wise Worksheets (continued)

Item Number	Deviation	Causes	Consequences	Safeguards	Recommendations
11.0 STEP - EXTEND BOOM OVER THE WATER (continued)					
11.12	slip/trip/fall		No consequences of interest		
11.13	Stress/strain/fatigue		See general personnel fatigue issues		
11.14	Exposure to		See general personnel exposure issues		
11.15	Process upset/ malfunction		No consequences of interest		
11.16	Layout/traffic/siting		No consequences of interest		
11.17	Tools/equipment		No consequences of interest		
12.0 STEP - LOWER RHI TO THE RAIL					
12.1	Missing		No missing steps identified		
12.2	Skip		No consequences of interest		
12.3	Part of		No consequences of interest		
12.4	Less		No consequences of interest		
12.5	More		No consequences of interest		

Table D.1C RHI Wise Worksheets (continued)

Item Number	Deviation	Causes	Consequences	Safeguards	Recommendations
12.0 STEP - LOWER RHI TO THE RAIL (continued)					
12.6	Out of sequence		Same as Less in the Extend Boom Over the Water step (Item 11.4)		
12.7	As well as		No consequences of interest		
12.8	Other than/reverse		No consequences of interest		
12.9	Caught in/on/by/ between		No consequences of interest		
12.10	Struck by/contact by	Frapping line tenders do not control sway of RHI - Same Items 10.4 (Less) and 10.5 (More) in the Tend RHI Frapping Lines step	Hazardous exposure - contact injury with swaying RHI Equipment damage/loss to RHI	Safety/deck supervisor monitors evolution	Deck personnel not positioned under RHI when lowered to rail
12.11	Contact with/struck against		No consequences of interest		
12.12	slip/trip/fall		No consequences of interest		
12.13	Stress/strain/fatigue		See general personnel fatigue issues		
12.14	Exposure to		See general personnel exposure issues		
12.15	Process upset/ malfunction		Same as Process upset/malfunction on the Swing the RHI Over the Water step (Item 8.16)		



Table D.1C RHI Wise Worksheets (continued)

Item Number	Deviation	Causes	Consequences	Safeguards	Recommendations
12.0 STEP - LOWER RHI TO THE RAIL (continued)					
12.16	Layout/traffic/siting		No consequences of interest		
12.17	Tools/equipment		No consequences of interest		
13.0 STEP - SNUG RHI AGAINST THE RAIL					
13.1	Missing		No missing steps identified		
13.2	Skip		No consequences of interest		
13.3	Part of		Same as Less		
13.4	Less (RHI loses its grip against rail)	Wet/icy conditions on side of vessel	Equipment damage/loss: damage to RHI Person overboard: slip/trip/fall during the Load Coxswain and Engineer into the RHI step (Item 14.12)	Deicing agents and ice removal practices Sides of RHI (pontoons) made of rubber (reduces chance of slipping)	
13.5	More	Articulating crane operator moves RHI to the rail too fast Deck supervisor orders RHI moved to rail too fast	Equipment damage/loss to the RHI	Safety supervisor monitors evolution	
13.6	Out of sequence		No consequences of interest		
13.7	As well as		No consequences of interest		

Table D.1C RHI Wise Worksheets (continued)

Item Number	Deviation	Causes	Consequences	Safeguards	Recommendations
13.0 STEP - SNUG RHI AGAINST THE RAIL (continued)					
13.8	Other than/reverse		No consequences of interest		
13.9	Caught in/on/by/ between		No consequences of interest		
13.10	Struck by/contact by		No consequences of interest		
13.11	Contact with/struck against		No consequences of interest		
13.12	Slip/trip/fall		No consequences of interest		
13.13	Stress/strain/fatigue		See general personnel fatigue issues		
13.14	Exposure to		See general personnel exposure issues		
13.15	Process upset/ malfunction		No consequences of interest		
13.16	Layout/traffic/siting		No consequences of interest		
13.17	Tools/equipment		No consequences of interest		

Table D.1C RHI Wise Worksheets (continued)

Item Number	Deviation	Causes	Consequences	Safeguards	Recommendations
14.0 STEP - LOAD COXSWAIN AND ENGINEER INTO RHI					
14.1	Missing		No missing steps identified		
14.2	Skip		No consequences of interest		
14.3	Part of		No consequences of interest		
14.4	Less		No consequences of interest		
14.5	More		No consequences of interest		
14.6	Out of sequence		Same as Slip/trip/fall (out of sequence with the Snug RHI Against the Rail step [Item 13.12])		
14.7	As well as		No consequences of interest		
14.8	Other than/reverse		No consequences of interest		
14.9	Caught in/on/by/ between		No consequences of interest		
14.10	Struck by/contact by		No consequences of interest		
14.11	Contact with/struck against		No consequences of interest		

Table D.1C RHI Wise Worksheets (continued)

Item Number	Deviation	Causes	Consequences	Safeguards	Recommendations
14.0 STEP - LOAD COXSWAIN AND ENGINEER INTO RHI (continued)					
14.12	Slip/trip/fall	<p>Personnel slip/trip/fall while loading into the RHI due to either high winds/seas or wet/icy conditions</p> <p>RHI loses grip on rail while personnel loading - see Snug RHI Against the Rail step (Item 13.4)</p>	<p>Person overboard and/or equipment damage/loss (overboard)</p>	<p>Safety/deck supervisor monitors evolution</p> <p>Deicing agents and ice removal practices</p>	
14.13	Stress/strain/fatigue		<p>See general personnel fatigue issues</p>		
14.14	Exposure to		<p>See general personnel exposure issues</p>		
14.15	Process upset/malfunction		<p>No consequences of interest</p>		
14.16	Layout/traffic/siting		<p>No consequences of interest</p>		
14.17	Tools/equipment		<p>No consequences of interest</p>		

Table D.1C RHI Wise Worksheets (continued)

Item Number	Deviation	Causes	Consequences	Safeguards	Recommendations
15.0 STEP - ESTABLISH APPROPRIATE LAUNCH COURSE/SPEED					
15.1	Missing		No missing steps identified		
15.2	skip	Deck crew launches RHI without permission from the bridge Bridge permits launch before course/speed established	Equipment damage/loss: damage to RHI due to excessive sway Person overboard and/or equipment damage/loss (overboard) due to excessive sway Person overboard and/or equipment damage/loss (overboard) if vessel must make emergency breakaway for course/speed	Multiple people on the bridge Safety supervisor monitors evolution and can communicate with the bridge	
15.3	Part of		No consequences of interest		
15.4	Less (steering too little in the intended direction)	Bridge misreads weather direction Conning officer orders wrong direction Helmsman sets wrong direction or drifts Steering system equipment failure	Potential for RHI to enter hazardous area (e.g., fishing area) during or after launch Person overboard and/or equipment damage/loss (overboard) Collision with another vessel	Multiple people on the bridge Safety supervisor monitors evolution and can communicate with the bridge	
15.5	Less (too little speed)		No consequences of interest		
15.6	More (steering too far in the intended direction)		Same as Less (steering)		

Table D.1C RHI Wise Worksheets (continued)

Item Number	Deviation	Causes	Consequences	Safeguards	Recommendations
15.0 STEP - ESTABLISH APPROPRIATE LAUNCH COURSE/SPEED (continued)					
15.7	More (too much speed)	Bridge misreads weather direction Comming officer orders wrong speed Helmsman sets wrong speed	Person overboard and/or equipment damage/loss (overboard) if vessel has excessively high speed	Multiple people on the bridge Safety supervisor monitors evolution and can communicate with the bridge	
15.8	Out of sequence		No consequences of interest		
15.9	As well as		No consequences of interest		
15.10	Other than/reverse		No consequences of interest		
15.11	Caught in/on/by/between		No consequences of interest		
15.12	Struck by/contact by		No consequences of interest		
15.13	Contact with/struck against		No consequences of interest		
15.14	Slip/trip/fall		No consequences of interest		
15.15	Stress/strain/fatigue		See general personnel fatigue issues		
15.16	Exposure to		No consequences of interest		

Table D.1C RHI Wise Worksheets (continued)

Item Number	Deviation	Causes	Consequences	Safeguards	Recommendations
15.0 STEP - ESTABLISH APPROPRIATE LAUNCH COURSE/SPEED (continued)					
15.17	Process upset/ malfunction		No consequences of interest		
15.18	Layout/traffic/siting		No consequences of interest		
15.19	Tools/equipment		No consequences of interest		
16.0 STEP - SWING RHI CLEAR OF THE RAIL					
16.1	Missing		No missing steps identified		
16.2	Skip	Deck supervisor orders RHI lowered without having it swung clear of the hull Articulating crane operator inadvertently lowers RHI while snugged to hull	Person overboard	Safety supervisor monitors evolution Boat crew feedback to deck supervisor if RHI starts tilting	
16.3	Part of		Same as Skip		
16.4	Less		Same as Skip		

Table D.1C RHI Wise Worksheets (continued)

Item Number	Deviation	Causes	Consequences	Safeguards	Recommendations
16.0 STEP - SWING RHI CLEAR OF THE RAIL (continued)					
16.5	More (swing RHI out too fast)	Articulating crane operator swings RHI out too fast Deck supervisor orders RHI swung out too fast Out of sequence (Item 16.6)	Equipment damage/loss to RHI Person overboard and/or equipment damage/loss (overboard) due to excessive sway Caught in/on/by/between (Item 16.9) Struck by/contact by (Item 16.10)	Safety/deck supervisor monitors evolution Boat crew feedback to deck supervisor Frapping line tenders limit sway of RHI Bridge deck officer can stop RHI lowering if permission not given to lower RHI	
16.6	Out of sequence	Deck supervisor fails to request permission from bridge Deck Officer to lower (out of sequence from establishing launch course)	More (swing RHI out too fast) (Item 16.5) Same as Skip in the Establish Appropriate Launch Course/Speed step (Item 15.2)		
16.7	As well as		No consequences of interest		
16.8	Other than/reverse		No consequences of interest		
16.9	Caught in/on/by/between	More (swing RHI out too fast) (Item 16.5)	Hazardous exposure - contact injury: hands/fingers caught between RHI and hull	Safety/deck supervisor monitors evolution Frapping line tenders limit sway of RHI	



Table D.1C RHI Wise Worksheets (continued)

Item Number	Deviation	Causes	Consequences	Safeguards	Recommendations
16.0 STEP - SWING RHI CLEAR OF THE RAIL (continued)					
16.10	Struck by/contact by	More (swing RHI out too fast) (Item 16.5)	Hazardous exposure - contact injury: RHI swings back into hull	Safety/deck supervisor monitors evolution	
16.11	Contact with/struck against		No consequences of interest		
16.12	Slip/trip/fall		No consequences of interest		Frapping line tenders limit sway of RHI
16.13	Stress/strain/fatigue		See general personnel fatigue issues		
16.14	Exposure to		See general personnel exposure issues		
16.15	Process upset/ malfunction		No consequences of interest		
16.16	Layout/traffic/siting		No consequences of interest		
16.17	Tools/equipment		No consequences of interest		

Table D.1C RHI Wise Worksheets (continued)

Item Number	Deviation	Causes	Consequences	Safeguards	Recommendations
17.0 STEP - LOWER RHI TO THE WATER					
17.1	Missing		No missing steps identified		
17.2	Skip		No consequences of interest		
17.3	Part of		Same as Less		
17.4	Less	Articulating crane hydraulics suddenly stops lowering RHI Deck supervisor orders sudden stop in lowering RHI	Person overboard and/or equipment damage/loss (overboard) due to sudden stop or if boom cable breaks	Safety supervisor monitors evolution Proper launch course reduces chance of having to stop lowering suddenly	
17.5	More	Deck supervisor orders RHI lowered too fast Articulating crane operator lowers RHI too fast	Person overboard and/or equipment damage/loss (overboard) due to impact when hitting water	Safety supervisor monitors evolution Proper launch course reduces chance of having to lower too fast	
17.6	Out of sequence		Same as Skip in the Swing RHI Clear of the Rail step (Item 16.2)		
17.7	As well as		No consequences of interest		
17.8	Other than/reverse		No consequences of interest		
17.9	Caught in/on/by/ between		No consequences of interest		

Table D.1C RHI Wise Worksheets (continued)

Item Number	Deviation	Causes	Consequences	Safeguards	Recommendations
17.0 STEP - LOWER RHI TO THE WATER (continued)					
17.10	Struck by/contact by	<p>Process upset/malfunction (equipment failure) (Item 17.15)</p> <p>High wave hits RHI</p> <p>Frapping line tenders do not control sway of RHI - Same as Items 10.4 (Less) and 10.5 (More) in the Tend RHI Frapping Lines step</p> <p>Improper launch course/speed (too much sway on RHI) - Same as Items 15.2 (Skip), 15.4 (Less), 15.6/7 (More) in the Establish Appropriate Launch Course/Speed step</p>	<p>Equipment damage/loss to RHI</p> <p>Person overboard and/or equipment damage/loss (overboard) due to excessive sway</p>	<p>Frapping line tenders limit sway of RHI</p> <p>Proper launch course/speed reduces excessive sway when lowering</p> <p>Articulating crane hydraulics system undergoes periodic maintenance</p> <p>RHI launch equipment inspected periodically</p>	
17.11	Contact with/struck against		No consequences of interest		
17.12	Slip/trip/fall		No consequences of interest		
17.13	Stress/strain/fatigue		See general personnel fatigue issues		
17.14	Exposure to		See general personnel exposure issues		
17.15	Process upset/malfunction	<p>Boom cable failure</p> <p>Articulating crane hydraulics failure</p>	Struck by/contact by (Item 17.10)		
17.16	Layout/traffic/siting		No consequences of interest		

Table D.1C RHI Wise Worksheets (continued)

Item Number	Deviation	Causes	Consequences	Safeguards	Recommendations
17.0 STEP - LOWER RHI TO THE WATER (continued)					
17.17	Tools/equipment		No consequences of interest		
18.0 STEP - START RHI ENGINE					
18.1	Missing		No missing steps identified		
18.2	Skip		No consequences of interest		
18.3	Part of		No consequences of interest		
18.4	Less		No consequences of interest		
18.5	More		No consequences of interest		
18.6	Out of sequence	Coxswain starts RHI engine before RHI fully in water	Equipment damage/Loss: damage to RHI engine due to overheating	Coxswain busy hanging on while lowering (hands are busy)	Safety/deck supervisor monitors evolution
18.7	As well as		No consequences of interest		
18.8	Other than/reverse		No consequences of interest		

Table D.1C RHI Wise Worksheets (continued)

Item Number	Deviation	Causes	Consequences	Safeguards	Recommendations
18.0 STEP - START RHI ENGINE (continued)					
18.9	Caught in/on/by/ between		No consequences of interest		
18.10	Struck by/contact by		No consequences of interest		
18.11	Contact with/struck against	Process upset/malfunction (Item 18.15)	Hazardous exposure - contact injury: RHI collides with hull of vessel  Equipment damage/loss: RHI collides with hull of vessel	Properly completing morning boat checks  Preventive maintenance on RHI systems  Safety/deck supervisor monitors evolution (can raise RHI back up)  Frapping line tenders and sea painter tender limit excess sway on RHI	
18.12	Slip/trip/fall		No consequences of interest		
18.13	Stress/strain/fatigue		See general personnel fatigue issues		
18.14	Exposure to		See general personnel exposure issues		
18.15	Process upset/ malfunction	Ignition system malfunction  Fuel not getting to MSB engine (water freezing or fuel line plugged up)	Contact with/struck against (Item 18.11)		
18.16	Layout/traffic/siting		No consequences of interest		

Table D.1C RHI Wise Worksheets (continued)

Item Number	Deviation	Causes	Consequences	Safeguards	Recommendations
18.0 STEP - START RHI ENGINE (continued)					
18.17	Tools/equipment		No consequences of interest		
19.0 STEP - RELEASE BOOM CABLE					
19.1	Missing	No missing steps identified			
19.2	Skip	Coxswain pulls away before cable released	Person overboard and/or equipment damage/loss (overboard): tilt RHI	Multiple people on deck make this unlikely	
19.3	Part of		No consequences of interest		
19.4	Less		No consequences of interest		
19.5	More		No consequences of interest		
19.6	Out of sequence		No consequences of interest		
19.7	As well as		No consequences of interest		
19.8	Other than/reverse	Same as Skip			
19.9	Caught in/on/by/between		No consequences of interest		

Table D.1C RHI Wise Worksheets (continued)

Item Number	Deviation	Causes	Consequences	Safeguards	Recommendations
19.0 STEP - RELEASE BOON CABLE (continued)					
19.10	Struck by/contact by	Boat engineer struck by cable hook as it is released	Hazardous exposure - contact injury	Proper launch course/speed reduces excess motion of RHI	5
				Cable hook not that heavy	
				Boat crew wears hard hats	
				Frapping line tenders and sea painter tender limit excess motion of RHI	
19.11	Contact with/struck against		No consequences of interest		
19.12	Slip/trip/fall		No consequences of interest		
19.13	Stress/strain/fatigue		See general personnel fatigue issues		
19.14	Exposure to		See general personnel exposure issues		
19.15	Process upset/malfunction		No consequences of interest		
19.16	Layout/traffic/siting		No consequences of interest		
19.17	Tools/equipment		No consequences of interest		

Table D.1C RHI Wise Worksheets (continued)

Item Number	Deviation	Causes	Consequences	Safeguards	Recommendations
20.0 STEP - LOAD PASSENGERS INTO RHI BY JACOB'S LADDER					
20.1	Missing		No missing steps identified		
20.2	Skip		No consequences of interest		
20.3	Part of		No consequences of interest		
20.4	Less		No consequences of interest		
20.5	More		No consequences of interest		
20.6	Out of sequence		No consequences of interest		
20.7	As well as		No consequences of interest		
20.8	Other than/reverse		No consequences of interest		
20.9	Caught in/on/by/ between		No consequences of interest		
20.10	Struck by/contact by		No consequences of interest		
20.11	Contact with/struck against		No consequences of interest		



Table D.1C RHI Wise Worksheets (continued)

Item Number	Deviation	Causes	Consequences	Safeguards	Recommendations
20.0 STEP - LOAD PASSENGERS INTO RHI BY JACOB'S LADDER (continued)					
20.12	slip/trip/fall	Passengers slip/trip/fall when loading due to wet/icy conditions or high winds/seas	Person overboard	Safety/deck supervisor monitors evolution	Frapping line tenders and sea painter tender limit excess motion on RHI
20.13	Stress/strain/fatigue		See general personnel fatigue issues		Proper launch course/speed limits excess motion on RHI
20.14	Exposure to		See general personnel exposure issues		
20.15	Process upset/malfunction		No consequences of interest		
20.16	Layout/traffic/siting		No consequences of interest		
20.17	Tools/equipment		No consequences of interest		

Table D.1C RHI Wise Worksheets (continued)

Item Number	Deviation	Causes	Consequences	Safeguards	Recommendations
21.0 STEP - RELEASE FRAPPING LINES					
21.1	Missing		No missing steps identified		
21.2	Skip		No consequences of interest		
21.3	Part of		Same as Less		
21.4	Less	Boat crew misses frapping lines when passed	Fouled screw on the RHI	Coxswain can throttle back	
21.5	More		No consequences of interest		
21.6	Out of sequence		Same as Slip/trip/fall in the Load Passengers into RHI by Jacob's Ladder step (Item 20.12)		
21.7	As well as		No consequences of interest		
21.8	Other than/reverse		No consequences of interest		
21.9	Caught in/on/by/between		No consequences of interest		
21.10	Struck by/contact by	Boat crew hit by frapping lines as lines thrown over to RHI	Hazardous exposure - contact injury	Boat crew wears hard hats	Event seems unlikely since the lines are not that heavy

Table D.1C RHI Wise Worksheets (continued)

Item Number	Deviation	Causes	Consequences	Safeguards	Recommendations
<b>21.0 STEP - RELEASE FRAPPING LINES (continued)</b>					
21.11	Contact with/struck against		No consequences of interest		
21.12	Slip/trip/fall		No consequences of interest		
21.13	Stress/strain/fatigue		See general personnel fatigue issues		
21.14	Exposure to		See general personnel exposure issues		
21.15	Process upset/malfunction		No consequences of interest		
21.16	Layout/traffic/siting		No consequences of interest		
21.17	Tools/equipment		No consequences of interest		
<b>22.0 STEP - MANEUVER RHI AWAY FROM THE VESSEL</b>					
22.1	Missing		No missing steps identified		
22.2	Skip		No consequences of interest		
22.3	Part of		No consequences of interest		

Table D.1C RHI Wise Worksheets (continued)

Item Number	Deviation	Causes	Consequences	Safeguards	Recommendations
22.0 STEP - MANEUVER RHI AWAY FROM THE VESSEL (continued)					
22.4	Less (RHI propulsion)	Coxswain underpowers RHI when maneuvering away Throttles stick	Contact with/struck against (Item 22.12)		
22.5	More (RHI propulsion)	Coxswain overpowers RHI when maneuvering away Throttles stick	Person overboard and/or equipment damage/loss (overboard): capsized RHI Contact with/struck against (Item 22.12)	New personnel supervised by experienced personnel alongside them Safety/deck supervisor monitors evolution Engine throttles checked during morning boat checks	
22.6	More (RHI steering)	Coxswain maneuvers RHI into vessel	Contact with/struck against (Item 22.12)		
22.7	Out of sequence		Same as Slip/trip/fall in the Load Passengers into RHI by Jacob's Ladder step (Item 20.12)		
22.8	As well as		Same as Less in the Release Frapping Lines step (Item 21.4)		
22.9	Other than/reverse		No consequences of interest		
22.10	Caught in/on/by/ between		No consequences of interest		
22.11	Struck by/contact by		No consequences of interest		

Table D.1C RHI Wise Worksheets (continued)

Item Number	Deviation	Causes	Consequences	Safeguards	Recommendations
22.0 STEP - MANEUVER RHI AWAY FROM THE VESSEL (continued)					
22.12	Contact with/struck against	Less (RHI propulsion) (Item 22.4) More (RHI steering) (Item 22.6) More (RHI propulsion) (Item 22.5)	Equipment damage/loss: RHI collides with hull of vessel Person overboard and/or equipment damage/loss (overboard); RHI collides with hull of vessel or if RHI impacts waves at higher speed	New personnel supervised by experienced personnel alongside them Safety/deck supervisor monitors evolution Engine throttles checked during morning boat checks	
22.13	Slip/trip/fall		No consequences of interest		
22.14	Stress/strain/fatigue		See general personnel fatigue issues		
22.15	Exposure to		See general personnel exposure issues		
22.16	Process upset/malfunction		No consequences of interest		
22.17	Layout/traffic/siting		No consequences of interest		
22.18	Tools/equipment		No consequences of interest		

Table D.1C RHI Wise Worksheets (continued)

Item Number	Deviation	Causes	Consequences	Safeguards	Recommendations
23.0 STEP - RELEASE SEA PAINTER					
23.1	Missing		No missing steps identified		
23.2	Skip	Coxswain fails to order sea painter released	Person overboard and/or equipment damage/loss (overboard): capsized RHI	Safety/deck supervisor monitors evolution	
23.3	Part of		No consequences of interest	Boat crew can warn coxswain	
23.4	Less		No consequences of interest		
23.5	More		No consequences of interest		
23.6	Out of sequence		Same as Less in the Release Frapping Lines step (Item 21.4) (difficult to release frapping lines with sea painter released)		
23.7	As well as		No consequences of interest		
23.8	Other than/reverse		No consequences of interest		
23.9	Caught in/on/by/between	Boat crewman inattention when releasing sea painter	Hazardous exposure - contact injury if caught in line	Boat crew trained specifically on how to avoid placing hands in vulnerable position	
23.10	Struck by/contact by		No consequences of interest		

Table D.1C RHI Wise Worksheets (continued)

Item Number	Deviation	Causes	Consequences	Safeguards	Recommendations
23.0 STEP - RELEASE SEA PAINTER (continued)					
23.11	Contact with/struck against		No consequences of interest		
23.12	Slip/trip/fall		No consequences of interest		
23.13	Stress/strain/fatigue		See general personnel fatigue issues		
23.14	Exposure to		See general personnel exposure issues		
23.15	Process upset/malfunction		No consequences of interest		
23.16	Layout/traffic/siting		No consequences of interest		
23.17	Tools/equipment		No consequences of interest		
24.0 STEP - MAKE SEA PAINTER READY FOR PASSING					
24.1	Missing		No missing steps identified		
24.2	Skip		Same as Skip In Pass the Sea Painter step (see Item 28.2)		
24.3	Part of		No consequences of interest		
24.4	Less		No consequences of interest		

Table D.1C RHI Wise Worksheets (continued)

Item Number	Deviation	Causes	Consequences	Safeguards	Recommendations
<b>24.0 STEP - MAKE SEA PAINTER READY FOR PASSING (continued)</b>					
24.5	More		No consequences of interest		
24.6	Out of sequence		No consequences of interest		
24.7	As well as		No consequences of interest		
24.8	Other than/reverse		No consequences of interest		
24.9	Caught in/on/by/ between		No consequences of interest		
24.10	Struck by/contact by		No consequences of interest		
24.11	Contact with/struck against		No consequences of interest		
24.12	Slip/trip/fall		No consequences of interest		
24.13	Stress/strain/fatigue		See general personnel fatigue issues		
24.14	Exposure to		See general personnel exposure issues		
24.15	Process upset/ malfunction		No consequences of interest		



Table D.1C RHI Wise Worksheets (continued)

Item Number	Deviation	Causes	Consequences	Safeguards	Recommendations
24.0 STEP - MAKE SEA PAINTER READY FOR PASSING (continued)					
24.16	Layout/traffic/siting		No consequences of interest		
24.17	Tools/equipment		No consequences of interest		
25.0 STEP - MAN RHI RECOVERY STATIONS					
25.1	Missing		No missing steps identified		
25.2	skip		No consequences of interest		
25.3	Part of		Same as Part of in the Man the RHI Launch Stations step (Item 4.3)		
25.4	Less		Same as Part of in the Man the RHI Launch Stations step (Item 4.3)		
25.5	More		No consequences of interest		
25.6	Out of sequence		No consequences of interest		
25.7	As well as		No consequences of interest		
25.8	Other than/reverse		Same as Other than/reverse in the Man the RHI Launch Stations (Item 4.8)		

Table D.1C RHI Wise Worksheets (continued)

Item Number	Deviation	Causes	Consequences	Safeguards	Recommendations
25.0 STEP - MAN RHI RECOVERY STATIONS (continued)					
25.9	Caught in/on/by/ between		No consequences of interest		
25.10	Struck by/contact by		No consequences of interest		
25.11	Contact with/struck against		No consequences of interest		
25.12	Slip/trip/fall		Same as Slip/trip/fall in the Man the RHI Launch Stations step (Item 4.12)		
25.13	Stress/strain/fatigue		See general personnel fatigue issues		
25.14	Exposure to		See general personnel exposure issues		
25.15	Process upset/ malfunction		No consequences of interest		
25.16	Layout/traffic/siting		No consequences of interest		
25.17	Tools/equipment		No consequences of interest		

Table D.1C RHI Wise Worksheets (continued)

Item Number	Deviation	Causes	Consequences	Safeguards	Recommendations
26.0 STEP - ESTABLISH APPROPRIATE RECOVERY COURSE/SPEED					
26.1	Missing		No missing steps identified		
26.2	Skip		Same as Skip in the Establish Appropriate Launch Course/Speed step (Item 15.2)		
26.3	Part of		No consequences of interest		
26.4	Less (steering too little in the intended direction)		Same as Less in the Establish Appropriate Launch Course/Speed step (Item 15.4)		
26.5	Less (too little speed)		No consequences of interest		
26.6	More (steering too far in the intended direction)		Same as Less (Item 26.4)		
26.7	More (too much speed)		Same as More (too much speed) in the Establish Appropriate Launch Course/Speed step (Item 15.7)		
26.8	Out of sequence		No consequences of interest		
26.9	As well as		No consequences of interest		
26.10	Other than/reverse		No consequences of interest		

Table D.1C RHI Wise Worksheets (continued)

Item Number	Deviation	Causes	Consequences	Safeguards	Recommendations
26.0 STEP - ESTABLISH APPROPRIATE RECOVERY COURSE/SPEED (continued)					
26.11	Caught in/on/by/ between		No consequences of interest		
26.12	Struck by/contact by		No consequences of interest		
26.13	Contact with/struck against		No consequences of interest		
26.14	Slip/trip/fall		No consequences of interest		
26.15	Stress/strain/fatigue		See general personnel fatigue issues		
26.16	Exposure to		No consequences of interest		
26.17	Process upset/ malfunction		No consequences of interest		
26.18	Layout/traffic/siting		No consequences of interest		
26.19	Tools/equipment		No consequences of interest		

Table D.1C RHI Wise Worksheets (continued)

Item Number	Deviation	Causes	Consequences	Safeguards	Recommendations
27.0 STEP - MANEUVER RHI ALONGSIDE THE VESSEL					
27.1	Missing		No missing steps identified		
27.2	Skip		No consequences of interest		
27.3	Part of		No consequences of interest		
27.4	Less (RHI propulsion)		Same as Less (RHI propulsion) in the Maneuver RHI Away From the Vessel step (Item 22.4)		
27.5	More (RHI propulsion)		Same as More (RHI propulsion) in the Maneuver the RHI Away From the Vessel step (Item 22.5)		
27.6	More (RHI steering)		Same as More (steering) in the Maneuver the RHI Away From the Vessel step (Item 22.6)		
27.7	Out of sequence		No consequences of interest		
27.8	As well as		No consequences of interest		
27.9	Other than/reverse		No consequences of interest		
27.10	Caught in/on/by/ between		No consequences of interest		

Table D.1C RHI Wise Worksheets (continued)

Item Number	Deviation	Causes	Consequences	Safeguards	Recommendations
27.0 STEP - MANEUVER RHI ALONGSIDE THE VESSEL (continued)					
27.11	Struck by/contact by		No consequences of interest		
27.12	Contact with/struck against		Same as Contact with/struck against in the Maneuver RHI Away From the Vessel step (Item 22.12)		
27.13	Slip/trip/fall	High sea state Boat crewman error	Person overboard when positioning for recovery	Boat crew kneels/crouches down to position for recovery	Coxswain monitors boat crew
27.14	Stress/strain/fatigue		See general personnel fatigue issues		
27.15	Exposure to		See general personnel exposure issues		
27.16	Process upset/malfunction		No consequences of interest		
27.17	Layout/traffic/siting		No consequences of interest		
27.18	Tools/equipment		No consequences of interest		

Table D.1C RHI Wise Worksheets (continued)

Item Number	Deviation	Causes	Consequences	Safeguards	Recommendations
28.0 STEP - PASS THE SEA PAINTER					
28.1	Missing		No missing steps identified		
28.2	Skip	Sea painter comes loose Recovery without the sea painter	Equipment damage/loss: potential to damage articulating crane boom Person overboard and/or equipment damage/loss (overboard): capsized RHI	Vessel can rig another line if sea painter lost Boat crew can remind the vessel if sea painter not present	
28.3	Part of		No consequences of interest		
28.4	Less		No consequences of interest		
28.5	More		No consequences of interest		
28.6	Out of sequence		No consequences of interest		
28.7	As well as		No consequences of interest		
28.8	Other than/reverse		No consequences of interest		
28.9	Caught in/on/by/ between	Boat crewman misses sea painter when passed Boat crewman error when hooking up the sea painter	Fouled screw on the RHI Hazardous exposure - contact injury: hands/fingers caught in the sea painter	Coxswain can throttle back if sea painter misses RHI New personnel supervised by experienced personnel alongside them Coxswain can monitor boat crewman	

Table D.1c RHI Wise Worksheets (continued)

Item Number	Deviation	Causes	Consequences	Safeguards	Recommendations
28.0 STEP - PASS THE SEA PAINTER (continued)					
28.10	Struck by/contact by		No consequences of interest		
28.11	Contact with/struck against		No consequences of interest		
28.12	Slip/trip/fall		Same as slip/trip/fall in the Maneuver RHI Alongside the Vessel step (Item 27.13)		
28.13	Stress/strain/fatigue		See general personnel fatigue issues		
28.14	Exposure to		See general personnel exposure issues		
28.15	Process upset/malfunction		No consequences of interest		
28.16	Layout/traffic/siting		No consequences of interest		
28.17	Tools/equipment		No consequences of interest		



Table D.1C RHI Wise Worksheets (continued)

Item Number	Deviation	Causes	Consequences	Safeguards	Recommendations
29.0 STEP - MANEUVER RHI UNDER THE BOOM					
29.1	Missing		No missing steps identified		
29.2	Skip		No consequences of interest		
29.3	Part of		No consequences of interest		
29.4	Less (RHI propulsion)	Coxswain error Stuck throttles	Equipment damage/loss: too much tension on sea painter and could break sea painter	New personnel supervised by experienced personnel alongside them Multiple people involved in the evolution who can notice that the RHI is not positioned correctly Throttles operated during morning boat checks	
29.5	Less (RHI steering)	RHI rudder does not compensate for vessel rudder changes	Person overboard and/or equipment damage/loss (overboard): capsized RHI	New personnel supervised by experienced personnel alongside them Multiple people involved in the evolution who can notice that the RHI is not positioned correctly Coxswain can use throttles to compensate	

Table D.1C RHI Wise Worksheets (continued)

Item Number	Deviation	Causes	Consequences	Safeguards	Recommendations
29.0 STEP - MANEUVER RHI UNDER THE BOOM (continued)					
29.6	More (RHI propulsion)	Coxswain error in causing too much slack in sea painter with subsequent line jerking Stuck throttles	Person overboard and/or equipment damage/loss (overboard): capsized RHI Contact with/struck against (Item 29.13)	New personnel supervised by experienced personnel alongside them Multiple people involved in the evolution who can notice that the RHI is not positioned correctly Throttles operated during morning boat checks	
29.7	More (RHI steering)	Coxswain error	Person overboard and/or equipment damage/loss (overboard): capsized RHI Contact with/struck against (Item 29.13)	New personnel supervised by experienced personnel alongside them Multiple people involved in the evolution who can notice that the RHI is not positioned correctly	
29.8	Out of sequence		Same as Skip in the Pass the Sea Painter step (Item 28.2)		
29.9	As well as		No consequences of interest		
29.10	Other than/reverse (RHI incorrectly positioned)	Coxswain error Coxswain incorrectly directed by Safety/Deck supervisor	Hazardous exposure - contact injury when raising RHI (sway) Equipment damage/loss: RHI when raising (sway) Person overboard and/or equipment damage/loss (overboard): when raising RHI (sway)	Multiple people involved in the evolution who can notice that the RHI is not positioned correctly Frapping line tenders limit sway on RHI	
29.11	Caught in/on/by/between		Same as More (RHI propulsion and steering)		

Table D.1C RHI Wise Worksheets (continued)

Item Number	Deviation	Causes	Consequences	Safeguards	Recommendations
29.0 STEP - MANEUVER RHI UNDER THE BOOM (continued)					
29.12	Struck by/contact by		No consequences of interest		
29.13	Contact with/struck against	More (RHI propulsion) (Item 29.6) More (RHI steering) (Item 29.7)	Hazardous exposure - contact injury Equipment damage/loss: damage the RHI	New personnel supervised by experienced personnel alongside them Safety/deck supervisor monitors evolution	Proper recovery course/speed limits excess motion on RHI
29.14	Slip/trip/fall		No consequences of interest		
29.15	Stress/strain/fatigue		See general personnel fatigue issues		
29.16	Exposure to		See general personnel exposure issues		
29.17	Process upset/malfunction		No consequences of interest		
29.18	Layout/traffic/siting		No consequences of interest		
29.19	Tools/equipment		No consequences of interest		

Table D.1C RHI Wise Worksheets (continued)

Item Number	Deviation	Causes	Consequences	Safeguards	Recommendations
<b>30.0 STEP - PASS FRAPPING LINES</b>					
30.1	Missing		No missing steps identified		
30.2	Skip		No consequences of interest		
30.3	Part of		Same as Less		
30.4	Less	Deck crew misses frapping lines when passed	fouled screw on RHI	Coxswain can throttle back	
30.5	More		No consequences of interest		
30.6	Out of sequence (Boat crew not expecting frapping lines)		Same as Less		
30.7	As well as		No consequences of interest		
30.8	Other than/reverse		No consequences of interest		
30.9	Caught in/on/by/between		No consequences of interest		
30.10	Struck by/contact by		Same as Struck by/contact by in the Release Frapping Lines step (Item 21.10)		
30.11	Contact with/struck against		No consequences of interest		

Table D.1C RHI Wise Worksheets (continued)

Item Number	Deviation	Causes	Consequences	Safeguards	Recommendations
30.0 STEP - PASS FRAPPING LINES (continued)					
30.12	Slip/trip/fall		No consequences of interest		
30.13	Stress/strain/fatigue		See general personnel fatigue issues		
30.14	Exposure to		See general personnel exposure issues		
30.15	Process upset/ malfunction		No consequences of interest		
30.16	Layout/traffic/siting		No consequences of interest		
30.17	Tools/equipment		No consequences of interest		
31.0 STEP - UNLOAD PASSENGERS BY JACOB'S LADDER					
31.1	Missing		No missing steps identified		
31.2	Skip		No consequences of interest		
31.3	Part of		No consequences of interest		
31.4	Less		No consequences of interest		
31.5	More		No consequences of interest		

Table D.1C RHI Wise Worksheets (continued)

Item Number	Deviation	Causes	Consequences	Safeguards	Recommendations
31.0 STEP - UNLOAD PASSENGERS BY JACOB'S LADDER (continued)					
31.6	Out of sequence		Same as Slip/trip/fall (out of sequence with Pass Frapping Lines step (Step 30))		
31.7	As well as		No consequences of interest		
31.8	Other than/reverse		No consequences of interest		
31.9	Caught in/on/by/between		No consequences of interest		
31.10	Struck by/contact by		No consequences of interest		
31.11	Contact with/struck against		No consequences of interest		
31.12	Slip/trip/fall		Same as Slip/trip/fall in the Load the Passengers into RHI by Jacob's Ladder step (Item 20.12)		
31.13	Stress/strain/fatigue		See general personnel fatigue issues		
31.14	Exposure to		See general personnel exposure issues		
31.15	Process upset/malfunction		No consequences of interest		
31.16	Layout/traffic/siting		No consequences of interest		

Table D.1C RHI Wise Worksheets (continued)

Item Number	Deviation	Causes	Consequences	Safeguards	Recommendations
31.0 STEP - UNLOAD PASSENGERS BY JACOB'S LADDER (continued)					
31.17	Tools/equipment		No consequences of interest		
32.0 STEP - LOWER BOOM CABLE					
32.1	Missing		No missing steps identified		
32.2	Skip		No consequences of interest		
32.3	Part of		No consequences of interest		
32.4	Less		No consequences of interest		
32.5	More		No consequences of interest		
32.6	Out of sequence		No consequences of interest		
32.7	As well as		No consequences of interest		
32.8	Other than/reverse		No consequences of interest		
32.9	Caught in/on/by/ between		No consequences of interest		

Table D.1C RHI Wise Worksheets (continued)

Item Number	Deviation	Causes	Consequences	Safeguards	Recommendations
32.0 STEP - LOWER BOOM CABLE (continued)					
32.10	Struck by/contact by		Same as Struck by/contact by in the Release Boom Cable step (Item 19.10)		
32.11	Contact with/struck against		No consequences of interest		
32.12	Slip/trip/fall		No consequences of interest		
32.13	Stress/strain/fatigue		See general personnel fatigue issues		
32.14	Exposure to		See general personnel exposure issues		
32.15	Process upset/malfunction		No consequences of interest		
32.16	Layout/traffic/siting		No consequences of interest		
32.17	Tools/equipment		No consequences of interest		



Table D.1C RHI Wise Worksheets (continued)

Item Number	Deviation	Causes	Consequences	Safeguards	Recommendations
<b>33.0 STEP - HOOK UP CABLE TO METAL RING</b>					
33.1	Missing		No missing steps identified		
33.2	Skip		No consequences of interest		
33.3	Part of		Same as Less		
33.4	Less	Boat crewman distracted and does not completely attach boom cable (perhaps due to high winds/seas)	Person overboard and/or equipment damage/loss (overboard): drop RHI when raising it out of the water	Easy to see if hook is in place Safety/deck supervisor monitors evolution Coxswain monitors boat crew	Proper recovery course/speed limits excess motion on RHI
33.5	More		No consequences of interest		
33.6	Out of sequence		No consequences of interest		
33.7	As well as		No consequences of interest		
33.8	Other than/reverse		No consequences of interest		

Table D.1C RHI Wise Worksheets (continued)

Item Number	Deviation	Causes	Consequences	Safeguards	Recommendations
33.0 STEP - HOOK UP CABLE TO METAL RING (continued)					
33.9	Caught in/on/by/ between	High sea state High winds	Hazardous exposure - contact injury: hands/fingers caught in cable hook	Proper recovery course/speed limits excess motion of RHI  Safety/deck supervisor monitors evolution  Coxswain monitors evolution	
33.10	Struck by/contact by		Same as Struck by/contact by in the Release Boom Cable step (Item 19.10)		
33.11	Contact with/struck against		No consequences of interest		
33.12	Slip/trip/fall	Improper position of person grabbing cable hook  High sea state High winds	Person overboard	Safety/deck supervisor monitor evolution  Coxswain monitors evolution	
33.13	Stress/strain/fatigue		See general personnel fatigue issues		
33.14	Exposure to		See general personnel exposure issues		
33.15	Process upset/ malfunction		No consequences of interest		
33.16	Layout/traffic/siting		No consequences of interest		
33.17	Tools/equipment		No consequences of interest		

Table D.1C RHI Wise Worksheets (continued)

Item Number	Deviation	Causes	Consequences	Safeguards	Recommendations
34.0 STEP - STOP THE RHI ENGINE					
34.1	Missing		No consequences of interest		
34.2	skip	Coxswain error	Equipment damage/loss: damage the RHI engine	Multiple people involved in the evolution make this event unlikely	
34.3	Part of		No consequences of interest		
34.4	Less		No consequences of interest		
34.5	More		No consequences of interest		
34.6	Out of sequence		No consequences of interest		
34.7	As well as		No consequences of interest		
34.8	Other than/reverse		No consequences of interest		
34.9	Caught in/on/by/ between		No consequences of interest		
34.10	Struck by/contact by		No consequences of interest		
34.11	Contact with/struck against		No consequences of interest		

Table D.1C RHI Wise Worksheets (continued)

Item Number	Deviation	Causes	Consequences	Safeguards	Recommendations
34.0 STEP - STOP THE RHI ENGINE (continued)					
34.12	Slip/trip/fall		No consequences of interest		
34.13	Stress/strain/fatigue		See general personnel fatigue issues		
34.14	Exposure to		See general personnel exposure issues		
34.15	Process upset/ malfunction		No consequences of interest		
34.16	Layout/traffic/siting		No consequences of interest		
34.17	Tools/equipment		No consequences of interest		
35.0 STEP - RAISE RHI TO THE RAIL					
35.1	Missing		No missing steps identified		
35.2	Skip		No consequences of interest		
35.3	Part of		Same as Less		
35.4	Less	Articulating crane hydraulics suddenly stops raising RHI Deck supervisor orders sudden stop in raising RHI	Person overboard and/or equipment damage/loss (overboard) due to sudden stop or if boom cable breaks		Safety supervisor monitors evolution Proper recovery course reduces chance of having to stop raising suddenly

Table D.1C RHI Wise Worksheets (continued)

Item Number	Deviation	Causes	Consequences	Safeguards	Recommendations
35.0 STEP - RAISE RHI TO THE RAIL (continued)					
35.5	More	Deck supervisor orders RHI raised too fast Articulating crane operator raises RHI too fast	Person overboard and/or equipment damage/loss (overboard) due to impact when hitting boom	Safety supervisor monitors evolution Proper recovery course reduces chance of having to raise too fast	
35.6	Out of sequence		Same as Slip/trip/fall in the Unload Passengers by Jacob's Ladder step (Item 31.12)		
35.7	As well as		No consequences of interest		
35.8	Other than/reverse		No consequences of interest		
35.9	Caught in/on/by/ between		No consequences of interest		
35.10	Struck by/contact by	Process upset/malfunction (Item 35.15) High wave hits RHI Frapping line tenders do not control sway of RHI - Same as Items 10.4 (Less) and 10.5 (More) in the Tend RHI Frapping Lines step Improper recovery course/speed (too much sway on RHI) - Same as Items 15.2 (Skip), 15.4 (Less), 15.6/7 (More) in the Establish Appropriate Launch Course/Speed step	Equipment damage/loss to RHI Person overboard and/or equipment damage/loss (overboard) due to excessive sway	Frapping line tenders limit sway of RHI Proper recovery course/speed reduces excessive sway when raising Articulating crane hydraulics system undergoes periodic maintenance	

Table D.1C RHI Wise Worksheets (continued)

Item Number	Deviation	Causes	Consequences	Safeguards	Recommendations
35.0 STEP - RAISE RHI TO THE RAIL (continued)					
35.11	Contact with/struck against		No consequences of interest		
35.12	Slip/trip/fall		No consequences of interest		
35.13	Stress/strain/fatigue		See general personnel fatigue issues		
35.14	Exposure to		See general personnel exposure issues		
35.15	Process upset/malfunction		Same as Process upset/malfunction in the Lower RHI to the Water step (Item 17.15)		
35.16	Layout/traffic/siting		Struck by/contact by (Item 35.10)	No consequences of interest	
35.17	Tools/equipment		No consequences of interest		

Table D.1C RHI Wise Worksheets (continued)

Item Number	Deviation	Causes	Consequences	Safeguards	Recommendations
36.0 STEP - SNUG RHI AGAINST THE RAIL					
36.1	Missing		No missing steps identified		
36.2	skip		No consequences of interest		
36.3	Part of		Same as Less		
36.4	Less		Same as Less in the Snug the RHI Against the Rail step (Item 13.4)		
36.5	More		Same as More in the Snug the RHI Against the Rail step (Item 13.5)		
36.6	Out of sequence		No consequences of interest		
36.7	As well as		No consequences of interest		
36.8	Other than/reverse		No consequences of interest		
36.9	Caught in/on/by/ between		No consequences of interest		
36.10	Struck by/contact by		No consequences of interest		
36.11	Contact with/struck against		No consequences of interest		

Table D.1C RHI Wise Worksheets (continued)

Item Number	Deviation	Causes	Consequences	Safeguards	Recommendations
36.0 STEP - SNUG RHI AGAINST THE RAIL (continued)					
36.12	Slip/trip/fall		No consequences of interest		
36.13	Stress/strain/fatigue		See general personnel fatigue issues		
36.14	Exposure to		See general personnel exposure issues		
36.15	Process upset/ malfunction		No consequences of interest		
36.16	Layout/traffic/siting		No consequences of interest		
36.17	Tools/equipment		No consequences of interest		
37.0 STEP - UNLOAD COXSWAIN AND ENGINEER					
37.1	Missing		No missing steps identified		
37.2	Skip		No consequences of interest		
37.3	Part of		No consequences of interest		
37.4	Less		No consequences of interest		
37.5	More		No consequences of interest		



Table D.1C RHI Wise Worksheets (continued)

Item Number	Deviation	Causes	Consequences	Safeguards	Recommendations
37.0 STEP - UNLOAD COXSWAIN AND ENGINEER (continued)					
37.6	Out of sequence		Same as Slip/trip/fall (out of sequence with the Snug RHI Against the Rail step [step 35])		
37.7	As well as		No consequences of interest		
37.8	Other than/reverse		No consequences of interest		
37.9	Caught in/on/by/ between		No consequences of interest		
37.10	Struck by/contact by		No consequences of interest		
37.11	Contact with/struck against		No consequences of interest		
37.12	Slip/trip/fall		Same as Slip/trip/fall in the Load Coxswain and Engineer into RHI step (Item 14.12)		
37.13	Stress/strain/fatigue		See general personnel fatigue issues		
37.14	Exposure to		See general personnel exposure issues		
37.15	Process upset/ malfunction		No consequences of interest		
37.16	Layout/traffic/siting		No consequences of interest		

Table D.1C RHI Wise Worksheets (continued)

Item Number	Deviation	Causes	Consequences	Safeguards	Recommendations
37.0 STEP - UNLOAD COXSWAIN AND ENGINEER (continued)					
37.17	Tools/equipment		No consequences of interest		
38.0 STEP - RAISE RHI INTO J-HOOKS					
38.1	Missing		No missing steps identified		
38.2	Skip		Same as Skip in the Raise the RHI into the J-Hooks step (Item 7.2)		
38.3	Part of		Same as Part of in the Raise the RHI into the J-hooks step (Item 7.3)		
38.4	Less		Same as Part of		
38.5	More		Same as More in the Raise the RHI into the J-hooks step (Item 7.5)		
38.6	Out of sequence		Same as Slip/trip/fall in the Unload Coxswain and Engineer step (Item 36.12)		
38.7	As well as		No consequences of interest		
38.8	Other than/reverse		Same as More and Part of		
38.9	Caught in/on/by/ between		No consequences of interest		
38.10	Struck by/contact by		Same as More		

Table D.1C RHI Wise Worksheets (continued)

Item Number	Deviation	Causes	Consequences	Safeguards	Recommendations
38.0 STEP - RAISE RHI INTO J-HOOKS (continued)					
38.11	Contact with/struck against		No consequences of interest		
38.12	slip/trip/fall		No consequences of interest		
38.13	Stress/strain/fatigue		See general personnel fatigue issues		
38.14	Exposure to		See general personnel exposure issues		
38.15	Process upset/malfunction		No consequences of interest		
38.16	Layout/traffic/siting		No consequences of interest		
38.17	Tools/equipment		No consequences of interest		
39.0 STEP - SWING RHI OVER TO CRADLE					
39.1	Missing		No missing steps identified		
39.2	skip		No consequences of interest		
39.3	Part of		Same as Less		

Table D.1C RHI Wise Worksheets (continued)

Item Number	Deviation	Causes	Consequences	Safeguards	Recommendations
39.0 STEP - SWING RHI OVER TO CRADLE (continued)					
39.4	Less (RHI not moved far enough over cradle)	Deck supervisor misjudges distance RHI moved Inboard	Equipment damage/loss: RHI damaged when lowered to the cradle	Involvement of multiple people on the deck makes lowering RHI onto cradle extremely unlikely	
39.5	More (RHI moved inboard too fast)	Deck supervisor orders RHI swung in too fast Articulating crane operator accidentally moves RHI in too fast	Struck by/contact by (Item 39.10)		
39.6	Out of sequence		Same as Skip in the Raise RHI onto J-hooks step (Item 7.2)		
39.7	As well as		No consequences of interest		
39.8	Other than/reverse (excess sway on RHI)	Frapping line tenders do not control sway of RHI - Same as Items 10.4 (Less) and 10.5 (More) in the Tend RHI Frapping Lines step	Struck by/contact by (Item 39.10)		
39.9	Caught in/on/by/ between		No consequences of interest		

Table D.1C RHI Wise Worksheets (continued)

Item Number	Deviation	Causes	Consequences	Safeguards	Recommendations
39.0 STEP - SWING RHI OVER TO CRADLE (continued)					
39.10	Struck by/contact by	Other than/reverse (Item 39.8) More (RHI moved inboard too fast) (Item 39.5) Process upset/malfunction (equipment failure) (Item 39.15) Process upset/malfunction (too much sway due to vessel course/speed) (Item 39.16)	Hazardous exposure - contact injury Equipment damage/loss to RHI	Safety supervisor monitors evolution Deck Supervisor controls actions of articulating crane operator Frapping line tenders control sway of RHI Deck personnel not positioned under RHI when swung over to the cradle RHI hydraulics system undergoes periodic preventive maintenance	
39.11	Contact with/struck against		No consequences of interest		
39.12	slip/trip/fall		No consequences of interest		
39.13	Stress/strain/fatigue		See general personnel fatigue issues		
39.14	Exposure to		See general personnel exposure issues		
39.15	Process upset/malfunction (equipment failure)		Same as Process upset/malfunction in Swing RHI over the Water step (Item 8.15) Struck by/contact by (Item 39.10)		
39.16	Process upset/malfunction (too much sway due to vessel course/speed)		Same as Process upset/malfunction in the Swing RHI over the Water step (Item 8.16) Struck by/contact by (Item 39.10)		

Table D.1C RHI Wise Worksheets (continued)

Item Number	Deviation	Causes	Consequences	Safeguards	Recommendations
39.0 STEP - SWING RHI OVER TO CRADLE (continued)					
39.17	Layout/traffic/siting		No consequences of interest		
39.18	Tools/equipment		No consequences of interest		
40.0 STEP - LOWER RHI TO CRADLE					
40.1	Missing		No missing steps identified		
40.2	Skip		No consequences of interest		
40.3	Part of		Same as Less		
40.4	Less (RHI not set in cradle)	Deck supervisor does not ensure RHI cradled properly	Caught in/on/by/between (Item 40.9)		
40.5	More (Lowered too fast)	Deck supervisor orders RHI lowered too fast Articulating crane operator lowers RHI too fast	Caught in/on/by/between (Item 40.9)		
40.6	Out of sequence		Same as Less in the Swing RHI over to Cradle step (Item 38.4)		
40.7	As well as		No consequences of interest		

Table D.1C RHI Wise Worksheets (continued)

Item Number	Deviation	Causes	Consequences	Safeguards	Recommendations
40.0 STEP - LOWER RHI TO CRADLE (continued)					
40.8	Other than/reverse	Frapping line tenders do not control sway of RHI - Same as Items 10.4 (Less) and 10.5 (More) in the Tend RHI Frapping Lines step	Struck by/contact by (Item 40.10)		
40.9	Caught in/on/by/ between	Less (RHI not set in cradle) (Item 40.4) More (Lowered too fast) (Item 40.5)	Hazardous exposure - contact injury: hands/fingers caught between RHI and cradle	Safety/deck supervisor monitors evolution	
40.10	Struck by/contact by	Other than/reverse (Item 40.8)	Hazardous exposure - contact injury: deck personnel struck by swaying RHI	Frapping line tenders control sway of RHI	
40.11	Contact with/struck against		No consequences of interest		
40.12	Slip/trip/fall		No consequences of interest		
40.13	Stress/strain/fatigue		See general personnel fatigue issues		
40.14	Exposure to		See general personnel exposure issues		
40.15	Process upset/ malfunction		No consequences of interest		
40.16	Layout/traffic/siting		No consequences of interest		
40.17	Tools/equipment		No consequences of interest		

Table D.1C RHI Wise Worksheets (continued)

Item Number	Deviation	Causes	Consequences	Safeguards	Recommendations
41.0 STEP - UNHOOK BOON CABLE					
41.1	Missing		No missing steps identified		
41.2	Skip		No consequences of interest		
41.3	Part of		No consequences of interest		
41.4	Less		No consequences of interest		
41.5	More		No consequences of interest		
41.6	Out of sequence		No consequences of interest		
41.7	As well as		No consequences of interest		
41.8	Other than/reverse		No consequences of interest		
41.9	Caught in/on/by/ between		No consequences of interest		



Table D.1C RHI Wise Worksheets (continued)

Item Number	Deviation	Causes	Consequences	Safeguards	Recommendations
41.0 STEP - UNHOOK BOOM CABLE (continued)					
41.10	Struck by/contact by	Deck crewman struck by boom hook when unhooking cable (perhaps due to high sea state or high winds)	Hazardous exposure - contact injury	Cable hook not very heavy Safety/deck supervisor monitors evolution	
				Safety supervisor can communicate with the bridge if vessel course/speed creates unstable recovery platform	
41.11	Contact with/struck against		No consequences of interest		
41.12	Slip/trip/fall	Deck crewman falls off RHI when unhooking the boom cable due to wet/icy conditions or high winds	Hazardous exposure - contact injury	Safety/deck supervisor monitors evolution	
				New personnel supervised by experienced personnel alongside them	
				Safety supervisor can communicate with the bridge if vessel course/speed creates unstable recovery platform	
41.13	Stress/strain/fatigue		See general personnel fatigue issues		
41.14	Exposure to		See general personnel exposure issues		
41.15	Process upset/malfunction		No consequences of interest		
41.16	Layout/traffic/siting		No consequences of interest		
41.17	Tools/equipment		No consequences of interest		

Table D.1C RHI Wise Worksheets (continued)

Item Number	Deviation	Causes	Consequences	Safeguards	Recommendations
<b>42.0 STEP - SECURE BOOM CABLE</b>					
42.1	Missing	No missing steps identified			
42.2	Skip	Articulating crane operator distracted and does not raise cable to secured position Deck supervisor does not direct cable secured	Hazardous exposure - contact injury: sheaving cable/hook	Cable hook not very heavy Safety supervisor monitors evolution	
42.3	Part of		Same as Skip		
42.4	Less		Same as Skip		
42.5	More		No consequences of interest		
42.6	Out of sequence		No consequences of interest		
42.7	As well as		No consequences of interest		
42.8	Other than/reverse		No consequences of interest		
42.9	Caught in/on/by/between		No consequences of interest		
42.10	Struck by/contact by		No consequences of interest		

Table D.1C RHI Wise Worksheets (continued)

Item Number	Deviation	Causes	Consequences	Safeguards	Recommendations
42.0 STEP - SECURE BOOM CABLE (continued)					
42.11	Contact with/struck against		No consequences of interest		
42.12	Slip/trip/fall		No consequences of interest		
42.13	Stress/strain/fatigue		See general personnel fatigue issues		
42.14	Exposure to		See general personnel exposure issues		
42.15	Process upset/malfunction		No consequences of interest		
42.16	Layout/traffic/siting		No consequences of interest		
42.17	Tools/equipment		No consequences of interest		
43.0 STEP - GRIPE RHI INTO THE CRADLE					
43.1	Missing		No missing steps identified		
43.2	Skip	Deck crew distracted and does not gripe the boat	Equipment damage/Loss: damage RHI if it moves in the cradle	Involvement of multiple people on the deck makes failure to gripe the RHI unlikely	
43.3	Part of		Same as Skip		
43.4	Less		Same as Skip		

Table D.1C RHI Wise Worksheets (continued)

Item Number	Deviation	Causes	Consequences	Safeguards	Recommendations
43.0 STEP - GRIPE RHI INTO THE CRADLE (continued)					
43.5	More		No consequences of interest		
43.6	Out of sequence		No consequences of interest		
43.7	As well as		No consequences of interest		
43.8	Other than/reverse		No consequences of interest		
43.9	Caught in/on/by/ between		No consequences of interest		
43.10	Struck by/contact by		No consequences of interest		
43.11	Contact with/struck against		No consequences of interest		
43.12	Slip/trip/fall	Personnel on top of RHI lose balance (perhaps due to high sea state, high winds, or wet/icy conditions)	Hazardous exposure - contact injury	Safety/deck supervisor monitors evolution New personnel supervised by experienced personnel alongside them Deicing agents and ice removal practices	
43.13	Stress/strain/fatigue		See general personnel fatigue issues		
43.14	Exposure to		See general personnel exposure issues		

Table D.1C RHI Wise Worksheets (continued)

Item Number	Deviation	Causes	Consequences	Safeguards	Recommendations
43.0 STEP - GRIPE RHI INTO THE CRADLE (continued)					
43.15	Process upset/ malfunction		No consequences of interest		
43.16	Layout/traffic/siting		No consequences of interest		
43.17	Tools/equipment		No consequences of interest		
44.0 STEP - SECURE AND STORE ALL GEAR					
44.1	Missing		No missing steps identified		
44.2	Skip	Deck crew rushed to get inside	Equipment damage/loss: lose equipment overboard	Safety/deck supervisor ensure all gear secured and stowed	14
44.3	Part of		Same as Skip		
44.4	Less		Same as Skip		
44.5	More		No consequences of interest		
44.6	Out of sequence		No consequences of interest		
44.7	As well as		No consequences of interest		
44.8	Other than/reverse		No consequences of interest		

Table D.1C RHI Wise Worksheets (continued)

Item Number	Deviation	Causes	Consequences	Safeguards	Recommendations
44.0 STEP - SECURE AND STORE ALL GEAR (continued)					
44.9	Caught in/on/by/ between		No consequences of interest		
44.10	Struck by/contact by		No consequences of interest		
44.11	Contact with/struck against		No consequences of interest		
44.12	Slip/trip/fall		Same as slip/trip/fall in the Man the RHI Launch Stations step (Item 4.12)		
44.13	Stress/strain/fatigue		See general personnel fatigue issues		
44.14	Exposure to		See general personnel exposure issues		
44.15	Process upset/ malfunction		No consequences of interest		
44.16	Layout/traffic/siting		No consequences of interest		
44.17	Tools/equipment		No consequences of interest		

**Table D.2C Consequences (Mishaps of Interest)**

<b>Mishap of Interest</b>	
Capsizing vessel	Drowning
Collision with another vessel	Person overboard
Collision with a fixed object	Hazardous exposure: contact injury
Collision with a floating object	Hazardous exposure: toxic/corrosive materials
Collision with helo	Hazardous exposure: electrical shock
Grounding vessel	Hazardous exposure: cold
Sinking vessel	environment/surface/material
Fouled screw	Hazardous exposure: hot
Fire/explosion	environment/surface/material
Firearm discharge	Hazardous exposure: asphyxiants
Equipment damage/loss	Hazardous exposure: noise
Loss of small boat	Hazardous exposure: radiation
Loss of helo	Hazardous exposure: biological materials

**Table D.3C General Personnel Issues Relating to Fatigue**

**Fatigue** — All vessel crew members are subject to certain levels of fatigue while performing duties at sea. This can impact a person’s ability to assess and respond to situations at all phases in evolutions.

<b>Generic Factors Affecting Fatigue</b>	<b>Generic Safeguards Against Fatigue</b>
<ul style="list-style-type: none"> <li>• Vessel crew understaffed for current missions</li> <li>• Low amounts of sleep</li> <li>• One or more events during operations requiring long, prolonged concentration</li> <li>• Inclement weather</li> <li>• Inadequate nutrition</li> <li>• Inadequate shipboard cleanliness</li> </ul>	<ul style="list-style-type: none"> <li>• Physical fitness standards</li> <li>• Command assessment of crew capability to respond to missions (also accounting for weather conditions)</li> <li>• Multiple personnel involved in operations decision making</li> <li>• Safety supervisors present during deck evolutions</li> <li>• Vessel health standards (including the galley)</li> <li>• Four meals served a day</li> </ul>

**Table D.4C General Personnel Issues Relating to Exposure**

**Exposure** — Both cold and hot weather conditions can severely impact vessel operations, especially for deck personnel. Inadequate protection from the weather elements can lower personnel performance and severely impact the health of crew members.

Generic Factors Affecting Exposure	Generic Safeguards Against Exposure
<ul style="list-style-type: none"> <li>• Inaccurate assessment of weather conditions</li> <li>• Personnel/supervisory inattention to individual exposure protection requirements</li> <li>• Supervisory inattention to longer duration or intense short duration exposure conditions</li> <li>• Insufficient amounts of exposure protection equipment onboard</li> <li>• Degradation of exposure protection equipment</li> </ul>	<ul style="list-style-type: none"> <li>• Multiple personnel involved in operations decision making</li> <li>• New personnel supervised by experienced personnel and by safety supervisors</li> <li>• Standard amounts of exposure protection equipment required to be carried onboard</li> <li>• Exposure equipment for deck personnel inspected by Deck Division on a periodic basis</li> </ul>



## **ATTACHMENT D**

### ***Human Factors (Error-Likely Situations) Review Worksheets***

The error-likely situations described in *A Managers Guide to Reducing Human Errors* (Chemical Manufacturers Association, 1990) are reviewed in this appendix for applicability to small boat operations.

**Table D.1D Human Factors Issues for Launching/Recovering Small Boats from USCG WMEC-270 Cutters**

<b>Error-Likely Situation</b>	<b>Key Areas of Applicability</b>	<b>Strengths in Current Practices</b>	<b>Weaknesses in Current Practices</b>	<b>Related Deviations</b>	<b>Actions</b>
<b>Deficient Procedures</b>	Procedures for launching/recovering the MSB and the RHI	Task-oriented, written procedures exist for launching/recovering the MSB and the RHI	The procedures for launching/recovering the MSB and the RHI could have a more user-friendly format  A few minor inconsistencies in procedures for launching/recovering the MSB and the RHI exist (e.g., the MSB recovery procedures do not have a step requiring the deck crew to insert the locking pins for the davits)	All small boat deviations potentially affected	6
<b>Inadequate, Inoperative, or Misleading Instrumentation</b>	Bridge instrumentation  Deck crews and boat crews do not use any special instrumentation while performing small boat launch/recovery operations	Bridge instrumentation used during small boat launch/recovery is clearly visible and consistent with other instrumentation on the bridge	No important weaknesses identified	Excessive sway during lowering/raising	

Table D.1D Human Factors Issues for Launching/Recovering Small Boats from USCG WMEC-270 Cutters (cont'd)

Error-Likely Situation	Key Areas of Applicability	Strengths in Current Practices	Weaknesses in Current Practices	Related Deviations	Actions
Insufficient Knowledge	<p>Knowledge of bridge observer and bridge crew</p> <p>Knowledge of deck supervisor and deck crew</p> <p>Knowledge of boat crew</p> <p>Knowledge of safety supervisor</p>	<p>The bridge observer for small boat operations is a senior officer (possibly a more junior officer in training under the direct supervision of a senior officer) with extensive experience related to small boat operations (i.e., the commanding officer, the executive officer, or the operations officer)</p> <p>The bridge crew receives training and performs drills related to small boat operations</p> <p>The deck supervisor is an experienced petty officer (or possibly a more inexperienced petty officer in training under the direct supervision of an experienced petty officer) with extensive experience related to small boat operations (i.e., BMC, BM2, or a BM3)</p> <p>The deck and boat crews receive training (mainly on-the-job training) and perform drills for small boat launching/recovering. The training and level of experience of deck and boat crew members determines their role in performing small boat operations</p> <p>The safety supervisor is an experienced officer or petty officer with extensive experience related to</p>	<p>If a normal member of a deck crew is unavailable (e.g., sick or busy with another important task) when conducting small boat operations, a less experienced crew member (potentially untrained in small boat operations) could be assigned to perform a noncritical role in small boat operations (e.g., a frapping line tender)</p>	<p>All small boat deviations potentially affected</p>	<p>1, 2, 6</p>

Table D.1D Human Factors Issues for Launching/Recovering Small Boats from USCG WMEC-270 Cutters (cont'd)

Error-Likely Situation	Key Areas of Applicability	Strengths in Current Practices	Weaknesses in Current Practices	Related Deviations	Actions
Conflicting Priorities	<p>Conflict between mission importance/urgency and risk acceptance</p> <p>Conflict between vessel/personal reputation for "getting the job done" and risk acceptance</p>	<p>A safety supervisor, whose only role is to ensure safety, observes small boat launching/recovering and takes action to correct any unsafe conditions/actions. The safety supervisor has a radio for verbal communication with the bridge and the small boat, and is positioned close to the deck crew performing small boat operations</p>	<p>The urgent nature of many USCG missions (e.g., search and rescue) creates conflicting priorities between accomplishing the mission and ensuring crew safety. Although crew safety is never ignored, unusual risks are sometimes accepted in order to accomplish the mission</p> <p>Although safety performance is considered when promotions are considered, a key factor in assigning promotions is an individual's effectiveness in their jobs. Conflicting priorities can arise between building a reputation for "getting the job done" and making reasonable risk acceptance decisions</p>	<p>All small boat deviations potentially affected</p>	<p>1</p>
Inadequate Labeling	<p>Labeling of bridge instrumentation and controls</p> <p>Labeling of deck equipment</p> <p>Labeling of lift controls</p>	<p>Labeling of equipment and controls seems appropriate for the application</p> <p>Labeling of items in the small boats and the labeling of safety equipment appears appropriate</p> <p>Labeling of lift controls seems appropriate for small boat operations</p>	<p>No important weaknesses identified</p>	<p>Movement in the wrong vertical and horizontal directions</p>	<p>None</p>

Table D.1D Human Factors Issues for Launching/Recovering Small Boats from USCG WMEC-270 Cutters (cont'd)

Error-Likely Situation	Key Areas of Applicability	Strengths in Current Practices	Weaknesses in Current Practices	Related Deviations	Actions
Inadequate Feedback	<p>Feedback from bridge instrumentation to bridge crew</p> <p>Feedback from bridge observer (OOD) to bridge crew</p> <p>Feedback from deck supervisor to deck crew (especially the lift operator)</p>	<p>Bridge instrumentation promptly updates vessel status conditions (speed, direction, etc.) whenever changes occur, generally with multiple indications of key conditions (multiple indicators of vessel direction, such as course/speed repeaters, DGPS, etc.)</p> <p>The bridge observer is positioned close to the bridge crew, allowing communication to occur freely</p>	<p>No important weaknesses identified</p>	<p>All small boat deviations potentially affected</p>	<p>None</p>
	<p>Feedback from the bridge observer (OOD) to boat crew (particularly during recovery)</p>	<p>The deck supervisor is positioned with the deck crew and the boat crew, allowing communication to occur freely</p>			
		<p>The bridge observer and boat crew are in radio contact during recovery operations, allowing communication to occur freely</p>			
		<p>The key monitoring mechanism for actions of the vessel, the launch/recovery team, and the small boat crew is visual observation by those performing the procedure. Most operations are conducted (or directed by) people making direct visual observations</p>			

Table D.1D Human Factors Issues for Launching/Recovering Small Boats from USCG WMEC-270 Cutters (cont'd)

Error-Likely Situation	Key Areas of Applicability	Strengths in Current Practices	Weaknesses in Current Practices	Related Deviations	Actions
Policy/Practice Discrepancies	<p>Procedure for launching/recovering the MSB and the RHI</p> <p>Safety policies for working on deck</p> <p>Safety policies for boat crews</p> <p>Policy requiring a safety supervisor for deck operations</p> <p>Communication protocols (radio, verbal, and hand signals)</p>	<p>All policies and procedures are routinely enforced, especially those with regard to safety</p>	<p>Crew members tend to be less vigilant and less concerned about risks when performing small boat operations in less risky situations (lowering small boats in port for drills, maintenance work, etc.). These situations may be more risky due to a lower perception of danger by deck/boat crews</p> <p>Crew members may become less rigorous about (or more likely to overlook) requirements after performing many small boat operations in a short period of time (e.g., during a fisheries patrol where many boardings are occurring daily), especially in adverse weather conditions. This same situation may also be caused by crew fatigue during particularly hectic tours where people performing small boat operations are tired/distracted from performing other activities on-board the vessel</p>	<p>All small boat deviations potentially affected</p>	<p>1, 2, 7</p>
Disabled Equipment	<p>Bridge instrumentation</p> <p>Lifting equipment and associated safeguards</p> <p>Communications equipment</p>	<p>Small boat operations would not occur if important equipment were not functional. Also, the hydraulics systems for both the MSB and RHI are equipped with a manual backup pump, and the MSB boom electric winch can be manually operated</p>	<p>No important weaknesses identified</p>	<p>Raising and lowering too slowly, Excessive sway during lowering/lowering/raising</p>	<p>None</p>

Table D.1D Human Factors Issues for Launching/Recovering Small Boats from USCG WMEC-270 Cutters (cont'd)

Error-Likely Situation	Key Areas of Applicability	Strengths in Current Practices	Weaknesses in Current Practices	Related Deviations	Actions
Poor Communication	<p>Communication between bridge observer and bridge crew</p> <p>Communication between deck supervisor and deck crew (especially the lift operator)</p> <p>Communication between the bridge observer and the boat crew (particularly during recovery)</p> <p>Communication between the safety supervisor and (1) the bridge observer, (2) the deck supervisor, and (3) the boat crew</p>	<p>All verbal orders are repeated back by the person receiving the order for confirmation by the person issuing the order</p> <p>The bridge observer is positioned close to the bridge crew, allowing verbal communication to occur freely</p> <p>The deck supervisor is positioned with the deck crew and the boat crew (before boarding the small boat), allowing verbal communication to occur freely</p> <p>The safety supervisor is positioned near the deck supervisor and deck crew, allowing verbal communications to occur freely</p> <p>The bridge observer, safety supervisor, and the boat crew (while in the small boat) are in radio contact, allowing verbal communication to occur freely</p> <p>The deck supervisor communicates to the lift operator verbally and through standard hand signals</p>	<p>In extreme conditions (e.g., severe weather conditions), verbal communications (especially those on deck and in the small boat) could be misunderstood</p>	<p>All small boat deviations potentially affected</p>	<p>None</p>

Table D.1D Human Factors Issues for Launching/Recovering Small Boats from USCG WMEC-270 Cutters (cont'd)

Error-Likely Situation	Key Areas of Applicability	Strengths in Current Practices	Weaknesses in Current Practices	Related Deviations	Actions
Poor Layout	<p>Deck area at small boat stations</p> <p>Lift equipment control stations</p> <p>Bridge control stations (bridge wings)</p>	<p>The lift equipment controls are logically positioned</p> <p>The bridge control station (starboard bridge wing) allows full view of the deck crew and MSB during MSB operations</p>	<p>To observe MSB raising and lowering, the deck supervisor must work at the side of the vessel (in a safety harness) where there are no rails in place. Also, the deck supervisor must stand in the area where the MSB could strike him/her while recovering the MSB</p>	<p>Movement in the wrong horizontal direction, Lowering/raising too quickly, Movement in the wrong vertical direction (RHI - when over the cradle)</p>	<p>12, None for deck supervisor</p>
Violations of Populational Stereotypes	<p>Communications protocols (radio, verbal, and hand signals)</p> <p>Bridge instrumentation and controls</p> <p>Lift equipment controls</p>	<p>Verbal communications protocols follow standard USCG guidelines</p> <p>Hand-signal communications follow standard USCG and industry guidelines</p> <p>Bridge instrumentation and controls do not violate the expectations of USCG crew members</p> <p>Lift equipment controls do not violate the expectations of USCG crew members</p>	<p>The bridge control station (port bridge wing) only allows a view of the RHI when it is swung over the water or in the water. The deck crew cannot be seen from the bridge</p> <p>No important weaknesses identified</p>	<p>Lowering/raising too quickly/slowly, Movement in the wrong vertical/horizontal direction, Excessive sway during lowering/raising</p>	



Table D.1D Human Factors Issues for Launching/Recovering Small Boats from USCG WMEC-270 Cutters (cont'd)

Error-Likely Situation	Key Areas of Applicability	Strengths in Current Practices	Weaknesses in Current Practices	Related Deviations	Actions
Overly Sensitive Controls	Bridge controls Lift equipment controls	Bridge controls are not overly sensitive to input adjustments Lift equipment controls are not overly sensitive to input adjustments	No important weaknesses identified	Lowering/raising too quickly/slowly, Movement in the wrong vertical/horizontal direction, Excessive sway during lowering/raising	None
Excessive Mental Tasks	Bridge observer Deck supervisor Safety supervisor	The bridge observer, deck supervisor, and safety supervisor each have focused responsibilities during small boat operations. Although they have to make difficult decisions at times, they are not required to perform "excessive" mental tasks	No important weaknesses identified	All small boat deviations potentially affected	None
Opportunities for Error	Number of small boat launches	Whenever practical, the number of small boat launches/recoveries is minimized by planning operations so that multiple boardings can occur from one launch	No important weaknesses identified	All small boat deviations potentially affected	None
Inadequate Tools	No special tools, other than safety gear, are identified as important for small boat operations	Safety gear (life vests, exposure suits, hard hats, etc.) appear to provide adequate protection when in place	Although providing protection when in place, hard hats tend to slip over the eyes and fall off. This could happen at a critical moment	All small boat deviations potentially affected	5

Table D.1D Human Factors Issues for Launching/Recovering Small Boats from USCG WMEC-270 Cutters (cont'd)

Error-Likely Situation	Key Areas of Applicability	Strengths in Current Practices	Weaknesses in Current Practices	Related Deviations	Actions
Sloppy Housekeeping	Deck area at small boat stations Small boat interior	Housekeeping at the small boat stations and in the small boats is good (i.e., gear is stowed and secured). Also, daily small boat operational and readiness checks are done by engineering and deck personnel	No important weaknesses identified	Loss of support	None
Extended, Uneventful Vigilance	No extended, uneventful vigilance issues identified for small boat operations	Not applicable	Not applicable		None
Computer Control Failure	No computer control failures identified as important for small boat operations	Not applicable	Not applicable		None
Inadequate Physical Restrictions	Deck crew strength Boat crew strength	Crew members must pass physical fitness tests	If a small boat were to fall during raising/lowering, boat crew members holding monkey lines would have to support themselves (on monkey lines) and climb back onto the deck. This could be physically demanding in adverse weather conditions (when use of the monkey lines may be most likely)	Loss of support, lowering too quickly	None

**Table D.1D Human Factors Issues for Launching/Recovering Small Boats from USCG WMEC-270 Cutters (cont'd)**

<b>Error-Likely Situation</b>	<b>Key Areas of Applicability</b>	<b>Strengths in Current Practices</b>	<b>Weaknesses in Current Practices</b>	<b>Related Deviations</b>	<b>Actions</b>
<b>Appearance at the Expense of Functionality</b>	Deck area at small boat stations	Equipment layout at the small boat stations is focused on function, not appearance	Lift equipment controls are labeled, but control levers for various motions are very similar in appearance	Lowering/raising too quickly/slowly, Movement in the wrong vertical/horizontal direction, Excessive sway during lowering/raising	None
	Lift equipment control stations	Bridge instrumentation and control layout is focused on function, not appearance			
	Bridge control stations				

## ***ATTACHMENT E***

### ***Procedural Format Upgrade for Launching a Motor Surf Boat (MSB)***

The new suggested format is based on procedure Deck Standing Order #2, MSB Lowering and Hoisting Procedures (from the *LEGARE*), which is found in Attachment A. The information contained in the new suggested format was not created by, nor is it necessarily endorsed by JBFA.

**DECK STANDING ORDER #2  
MSB LOWERING AND HOISTING PROCEDURES**

*Precautions*

- Deck and MSB personnel should be aware of weather conditions and deck conditions (slippery/icy). Personnel should suit up as appropriate.
- New personnel should be assigned to experienced personnel to learn how to safely perform their functions in the evaluation.
- All personnel should know where to find safety gear as quickly as possible.
- Deck personnel should speak up if all required personnel are not present or if they see a dangerous condition developing.
- Morning boat checks are performed by Deck Division (checkoff sheet goes to the Deck Division Leading Petty Officer) and Engineering (checkoff sheet goes to the Officer of the Deck). These people should be contacted if there is any doubt concerning completion of the boat checks.
- No matter how urgent the situation, do not rush — **Safety First.**

*Billeting*

The lowering/hoisting detail shall consist of the following personnel (as a minimum):

**Table D.1E MSB Lowering and Hoisting Detail**

BILLET	POSITION	STATION
BMC, BM2, BM3	In Charge	Boat Deck
1LT, BMC, BM2, BM3	Safety Observer	Boat Deck
As Directed	Coxswain	Boat Deck
As Directed	Crewman	Boat Deck
As Directed	Sea Painter Tender	Forecastle
As Directed	Frapping Line Tender - FWD	Forward Davit
As Directed	Frapping Line Tender - AFT	Aft Davit
As Directed	Davit/Winch Operator	Controls
As Directed	Communications (VHF)	Provided by BMOW

Note: Abnormal or emergency actions are annotated by an asterisk (\*) in the right hand column of the following procedure under Notes and Safety Issues.

**Table D.2E MSB Lowering and Hoisting Procedure**

<i>PROCEDURE</i>	<i>NOTES AND SAFETY ISSUES</i>
<b>Muster on Station/Prepare the MSB</b>	
<ol style="list-style-type: none"> <li>1. Upon hearing "MAKE PREPARATIONS FOR LOWERING THE STARBOARD SMALL BOAT," the lowering detail and boat crew muster aft of the MSB.</li> <li>2. All hands man their stations.</li> <li>3. The boat crew lays to the loading platform after the Officer/Petty Officer in charge (POIC) receives <i>permission</i> from Officer of the Deck (OOD).</li> <li>4. The boat crew ungripes the MSB, releases the preventers and lowers the lifelines (monkey lines). No one enters the MSB unless the POIC receives <i>permission</i> from the OOD.</li> <li>5. After the MSB is ungriped, all personnel lay out of MSB and standby.</li> <li>6. The POIC receives ready reports as follows:               <ol style="list-style-type: none"> <li>(1) "Ready on the sea painter"</li> <li>(2) "Ready forward"</li> <li>(3) "Ready aft"</li> <li>(4) "Ready on the boat lowering platform"</li> </ol> </li> </ol>	<ul style="list-style-type: none"> <li>• Anti-exposure suits are worn if sea temperature is less than 60 °F.</li> <li>• All personnel don hard hats and life vests.</li> <li>• The person releasing the gripe strap underneath MSB should be careful to not get struck by the gripe hook when the strap is released.</li> <li>• Frapping tenders assist boat crew in ungriping MSB as directed.</li> <li>• No one is in MSB when being lowered to the rail.</li> <li>• These reports are made from the sea painter tender, frapping line tenders, and davit/winch operator respectively.</li> </ul>

**Table D.2E MSB Lowering and Hoisting Procedure (cont'd)**

<i>PROCEDURE</i>	<i>NOTES AND SAFETY ISSUES</i>
<p><b>Uncradle MSB and Put it to the Rail</b></p> <p>7. After receiving ready reports, the POIC requests <i>permission</i> from the OOD to uncradle the MSB as follows: "Manned and ready, request permission to put the boat to the rail."</p> <p>8. After receiving permission, the POIC raises the MSB approximately 6 inches before ordering the shoes released. The POIC then executes the following sequence of orders:</p> <ol style="list-style-type: none"> <li>(1) "Stand by your lines"</li> <li>(2) "Release shoes"</li> <li>(3) Receives reports of "Fore shoe released" and "Aft shoe released"</li> <li>(4) "Remove pins"</li> <li>(5) Receives reports of "Fore pin removed" and "Aft pin removed"</li> </ol> <p>9. The POIC directs the davit/winch operator to breast the MSB outboard.</p>	<ul style="list-style-type: none"> <li>• The frapping line tenders release the shoes and remove the retaining pins and report completion of these actions when ordered to do so by the POIC.</li>   <li>• <b>Only</b> the POIC (or Safety Supervisor in an emergency) issues davit/winch movement commands to the davit/winch operator (done by hand signals).</li> <li>• The frapping line tenders maintain medium tension on the frapping lines when the MSB is hanging (moving it outboard or lowering it) to prevent excessive sway (and perhaps damage) on the MSB. The frapping line tenders should be careful not to catch their fingers in the cleats supporting the frapping lines.</li> <li>* In the event of a hydraulic pump casualty (loss of power or pump failure), two people from engineering can operate the manual hand pump to reocradle the MSB.</li> </ul>

**Table D.2E MSB Lowering and Hoisting Procedure (cont'd)**

<i>PROCEDURE</i>	<i>NOTES AND SAFETY ISSUES</i>
<p>10. The POIC orders the davit/winch operator to lower the MSB to the rail and snug it against the hull with a slight canter inboard.</p>	<ul style="list-style-type: none"> <li>• The canter helps keep the MSB snugged against the hull while loading personnel and equipment. Deck personnel should be on guard for the MSB slipping free while in this condition.</li> <li>* In the event of a winch casualty (loss of power or motor failure), two people on deck can manually hoist up the MSB.</li> <li>* If the MSB slips free or begins to slip free, notify the POIC immediately.</li> </ul>
<p><b>Load the MSB</b></p>	
<p>11. The POIC requests <i>permission</i> from the OOD to "Man the boat."</p>	
<p>12. After receiving permission, the POIC orders the MSB crew and passengers into the boat.</p>	<ul style="list-style-type: none"> <li>• Unless otherwise directed, no more than seven (7) people at a time will be lowered in the MSB to prevent overloading the fall lines. Additional passengers will be loaded from the ship's starboard aft quarter when the MSB is waterborne.</li> <li>• Boat personnel shall not step on the MSB gunwale while loading (they could slip or knock the MSB free of its snug fit).</li> <li>* If someone falls over the side while loading, anyone seeing this shall call away "Man overboard - starboard side." The POIC shall report this to the bridge.</li> </ul>
<p>13. The POIC and coxswain ensure that an appropriate number of monkey lines are dropped over the outboard side of the MSB.</p>	<ul style="list-style-type: none"> <li>• Each boat crewman shall support approximately 80% of his/her weight on a monkey line while lowering.</li> </ul>



**Table D.2E MSB Lowering and Hoisting Procedure (cont'd)**

<i>PROCEDURE</i>	<i>NOTES AND SAFETY ISSUES</i>
<p><b>Lower the MSB to the Water</b></p> <p>14. When all is ready in the MSB, the coxswain reports to the POIC "Ready in the boat." The POIC then requests <i>permission</i> from the OOD to "Lower the boat."</p> <p>15. After receiving permission, the POIC directs the davit/winch operator to swing the MSB clear of the hull and lower the MSB to water.</p>	<ul style="list-style-type: none"> <li>• This step is done as quickly as possible without compromising safety.</li> <li>• The POIC directs an appropriate lowering speed (fast or slow) depending on the sea conditions. Also, the POIC wants to ensure that the fall lines are lowered until the fall tensioner arms come all the way down. This makes sure that (1) there is not too much tension on the fall lines so that the boat crew can release the blocks and (2) at the same time, there is enough tension so that the cable does not bird nest on the winch drum.</li> <li>• The boat crew is vulnerable at this point and the frapping line tenders should especially be on guard to limit sway on the MSB.</li> <li>• The boat crew should always hang onto the monkey lines and not place their hands or legs over the side of the MSB (could get them caught between the MSB and the hull of the ship).</li> <li>* If someone falls over the side while lowering or if one or both fall lines break, anyone seeing this shall call away "Man overboard - starboard side." The POIC shall report this to the bridge.</li> <li>* In the event of a hydraulic rupture, the davit arms will fully extend out. The MSB can still be raised/lowered by the winch.</li> </ul>

**Table D.2E MSB Lowering and Hoisting Procedure (cont'd)**

<i>PROCEDURE</i>	<i>NOTES AND SAFETY ISSUES</i>
<p>15. <i>Continued</i></p> <p><b>Start and Release the MSB</b></p> <p>16. When waterborne, the boat crew places the monkey lines on the inboard side of the MSB. The Coxswain starts the MSB.</p> <p>17. The coxswain executes the following sequence of orders:</p> <p>(1) "Release aft"            (2) Receives the reply "Released aft"            (3) "Release forward"            (4) Receives the reply "Released forward"</p> <p>18. The coxswain maneuvers the MSB away from the ship while riding the sea painter.</p>	<ul style="list-style-type: none"> <li>* In the event of a winch casualty (loss of power or motor failure), two people on deck can manually hoist up or continue to lower the MSB. If this fails, the boat crew can climb up to the deck using the monkey lines.</li>   <li>• The boat crew should watch not to tangle the monkey lines as they pass them inboard.</li> <li>• The boat engineer shall ensure that the MSB achieves overboard water discharge when the engine is started.</li> <li>* If the engine does not start, the coxswain reports this to the OOD via hand-held radio or by voice to the POIC. The POIC can raise the MSB back up to the rail.</li>   <li>• Communication between the coxswain and other boat crew members is extremely important at this point to make sure that the aft block is released before the forward block. Else, the MSB could spin and possibly capsize.</li> <li>• After releasing the blocks, boat crewman should hold onto the blocks until the frapping line tenders can pull the blocks into the side of the ship.</li> <li>* If someone falls over the side due to the MSB becoming swamped or capsizing, anyone seeing this shall call away "Man overboard - starboard side." The POIC shall report this to the bridge.</li>   <li>• The sea painter tender shall ensure that the sea painter does not develop too much slack and slip under the MSB (may get caught in the screw of the MSB).</li> </ul>

**Table D.2E MSB Lowering and Hoisting Procedure (cont'd)**

<i>PROCEDURE</i>	<i>NOTES AND SAFETY ISSUES</i>
19. The coxswain orders the forward boat crewman to release the sea painter.	<ul style="list-style-type: none"> <li>• The forward boat crewman should be careful not to get caught in the sea painter as it is released.</li> </ul>
20. As soon as the sea painter is released, the sea painter tender shall heave around smartly to pull the sea painter away from the MSB and out of the water.	<ul style="list-style-type: none"> <li>• This prevents the sea painter from getting caught in the screw of the MSB.</li> </ul>
21. The coxswain maneuvers the MSB away from the ship.	<ul style="list-style-type: none"> <li>• At this point, the coxswain is in direct communication with the OOD via hand-held radio.</li> <li>* If all radios on the MSB are lost or become inoperative, the coxswain can establish voice contact or use hand signals with the boat deck.</li> </ul>
22. The sea painter tender shall make the sea painter ready for passing for MSB recovery.	

## **Attachment E**

### ***Detailed Hazard Analysis of WLIC-160 Deck Operations***

This attachment contains the results of a detailed risk analysis (formerly called detailed hazard analysis) of WLIC-160 deck operations. The what-if analysis technique was used for this study. Included are typical results produced by the analysis and the raw data collected during the analysis sessions. Because of the specific expertise required, most detailed analyses like this will be performed by outside experts in the techniques, rather than by Coast Guard personnel.

JBFA-101-01-05-94

**UNITED STATES COAST GUARD (USCG)  
HAZARD ANALYSIS PROJECT  
FINAL REPORT  
(TASK 5)**

***DETAILED HAZARD ANALYSIS OF  
WLIC-160 DECK OPERATIONS***

Vernon H. Guthrie  
Dale F. Nawrocki  
David A. Walker  
Thomas F. Zanin

**JBF Associates, Inc.  
1000 Technology Drive  
Knoxville, TN 39732-3353**

July 31, 1996

This work is being performed for the United States Coast Guard under Delivery Order DTCG39-95-F-E00315 of Contract Number DTCG39-95-D-E00395

## ***C.1 Introduction***

Based on the results of the preliminary hazard analysis (PHA) previously performed on the *KENNEBEC*, ATON operations were selected for more detailed hazard analysis. Personnel from JBFA met with members of the *KENNEBEC* crew from April 8 through April 10, 1996, to (1) review ATON operating procedures, (2) observe actual ATON operations, and (3) perform detailed hazard analysis using the what-if analysis technique.

ATON operations were selected for more detailed analysis because the PHA characterized the risks associated with these operations as the highest risk operations aboard this vessel. The PHA results estimated that these operations (1) have an Improbable (i.e., unlikely, but reasonably expected to occur; a 10% to 100% chance over a 50-year period) chance of resulting in a Class A or Class B mishap and (2) may Occasionally (i.e., occur periodically; every 1 to 10 years) occur in a Class C or Class D mishap. The team performing the PHA generally expressed a high level of confidence in their risk characterizations for ATON operations. Therefore, the purpose of more detailed hazard analysis is to use more in-depth evaluation/observation of ATON operations to (1) assess the accuracy of the PHA results and update those results as necessary and (2) develop more specific recommendations to help reduce the risks, if warranted.

## ***C.2 Scope***

The objectives of the analysis were to (1) identify hazards that could lead to consequences of interest and (2) recommend ways for reducing the risks associated with these hazards. Consequences of interest include personnel/public injury/illness, USCG vessel loss/damage, and USCG/private equipment/property damage.

The analytical scope for this study includes all types of mishaps uniquely related to ATON operations and the equipment used in such operations, focusing on deck operations. The analysis was performed on all elements of ATON operations, including: approaching an aid, positioning the vessel, retrieving an aid, crane operations, lifting and driving piles, and positioning an aid. The analysis included an evaluation of environmental, mechanical, and human factor contributors to potential mishaps.

### ***C.3 System Description***

The main function of the *KENNEBEC* is to repair and install various aids to navigation. An aid is typically installed on a pile (or group of piles), and is positioned to guide vessel traffic in navigable waterways. The vessel is equipped with four spuds that are used to (1) help position the vessel by lowering one or two spuds and using the engines to maneuver the vessel and (2) maintain vessel position by lowering all four spuds. A crane is used to recover wreckage and temporary aids from the water, and is also used to lift and position piles for installation. The piles are either wood or steel, depending on the expected floor conditions and style of aid to be installed.

After the vessel is in position for constructing an aid, the first step in preparation for driving a pile is raising the lead. The lead is the piece of equipment which includes the diesel-driven pile driver and an I-beam to hold the driver and the piles. A cross-deck winch is connected to one end of a pile to help control movement of the pile, and the crane hoist is connected to the other end of the pile. (Slings are used for the winch/hoist connections.) When a pile is in a vertical position, the pile is disconnected from the cross-deck winch and connected to the lead, but remains connected to the crane hoist.

Next, the pile driver is lowered into position on the upper end of the pile, and the pile is driven into the sea/river floor. If needed, additional piles are driven to form the structure needed for the aid, or the aid is attached to the single pile. Finally, using extension platforms from the deck, crew members install the markers, signs, fixtures, lights, etc. on the structure to complete the aid.

### ***C.4 Analysis Approach***

The analysis was performed using the what-if analysis technique. This technique was chosen because (1) ATON deck operations invoke coordinated efforts of equipment and human operations, (2) the PHA had already expressed a high degree of confidence in their risk characterizations, and (3) mishaps during ATON deck operations are not likely to involve complex combination of equipment failures and human error that would necessitate the use of more sophisticated techniques (e.g., FTA/ETA). In what-if analysis, the analysis team generates a list of questions and considers the safety implications associated with the questions. For scenarios that could result in a consequence of interest, the team reviews the safeguards that either (1) help reduce the likelihood that the consequence occurs or (2) help mitigate the consequence. When the team believed additional safeguards may be warranted, the team developed recommendations to help reduce the risks. Table C.1 lists the members of the what-if analysis review team.

**Table C.1 Members of the What-If Analysis Review Team**

---

<b>Team Members<sup>1, 2</sup></b>
CWO Kalista, <i>USCG KENNEBEC</i>
BMC Sawyer, <i>USCG KENNEBEC</i>
MKC Edmunson, <i>USCG KENNEBEC</i>
QM2 Smith, <i>USCG KENNEBEC</i>
Mr. Nawrocki, JBFA
Mr. Walker, JBFA

---

<sup>1</sup> CWO Borlase from USCG Headquarters attended the first day of the what-if analysis meetings as an observer/liason.

<sup>2</sup> Various members of the *KENNEBEC* crew participated in the review on an as-needed basis to answer specific questions and to obtain their perspective of the most significant risks associated with ATON operations.

### ***C.5 Results***

Table C.2 (at the end of this appendix) summarizes the what-if analysis review of ATON operations for *KENNEBEC*, focusing on ATON deck operations.

What-If questions are listed in the first column of the table. The questions were generated by the analysis team postulating a variety of process upsets, equipment failures, and human errors that potentially could cause an undesirable consequence. Questions were sometimes added to the list based on the team's responses to other what-if questions.

The Responses column in the what-if table identifies the hazards and consequences associated with each what-if question postulated by the team. These consequences include items such as equipment damage and personnel injury. The consequences that are listed should be interpreted as reasonable worst-case scenarios that the team developed by assuming the most severe and/or persistent event and assuming that none of the listed safeguards work. For these reasons, the team believes that the Coast Guard would usually experience much less severe consequences than those listed in this column.



“No consequence of interest” was entered in the **Responses** column whenever the team did not identify consequences of interest (as defined in Section C.2).

**Safeguards** are equipment features and procedural steps intended to (1) reduce the likelihood of one or more causes producing the given consequence(s) or (2) reduce the severity of the given consequence(s). The what-if table lists only the specific safeguards directly applicable to a possible cause or potential consequence of a scenario. Typically, the safeguards listed for a particular scenario are physically located in, or otherwise directly applicable to, the process section being reviewed.

The last column in the what-if table, **Recommendations**, refers to specific suggestions that are described in Section C.6. These recommendations are strictly the suggestions of the analysis team. There may be more effective alternatives for protecting against some hazards, and some recommendations may not be feasible.

No substantial changes to the PHA results were made based on the what-if analysis results because the PHA results were judged to have accurately reflected the potential mishaps. No changes in the overall risk characterization for the *KENNEBEC* were warranted.

### ***C.6 Recommendations***

The *KENNEBEC* has many features that either (1) help prevent accidents or (2) help limit the severity of accidents. Based on the results and insights gained from performing this analysis, several recommendations for improvement were identified. These suggestions fall into two categories: *Recommendations for Current Operations Aboard the KENNEBEC* and *Recommendations for Improvements with Future USCG Construction Tenders*. The first set of recommendations may help reduce current risks aboard *KENNEBEC*. The second set of recommendations are based on observations that are probably impractical for implementation aboard *KENNEBEC*, but should receive consideration when the USCG decides to commission a new construction tender (or significantly overhaul an existing tender).

#### **Recommendations for Current Operations Aboard *KENNEBEC***

***Recommendation 1*** — *Consider ensuring that the operator for Spud #3 does not climb over the steel piles to man his/her station, especially when the steel piles are wet, icy, or unevenly stacked.* When long steel piles are stored on board (most of the time), the steel piles block direct access between the working deck and Spud #3. Although there is a path from the working deck through the DC shop to the Spud #3 control station, the operator for Spud #3 frequently crawls over the steel piles to man his/her station. This creates the potential for injury if (1) the Spud #3

operator slips/trips over the piles (especially in wet/icy conditions) or (2) the piles move in their rack as the operator crawls over the piles.

***Recommendation 2 — Consider modifying the crane boom to provide grating within the structure of the boom as a walkway for the person conducting the daily crane inspection.*** A member of the crew inspects the crane each day the crane is used. This inspection involves visual observation of cables, pulleys, pins, etc. in the boom while a crew member climbs along the boom as it rests in its cradle on deck. Serious injury could result if the crew member fell from the boom. At one time, the USCG had designed a grating to address the intent of this recommendation. However, the design proved impractical (and perhaps unsafe) because the location of that grating would have required the crane inspector to walk along the top of the boom (rather than within the frame of the boom), which could be quite challenging, especially when underway.

#### **Recommendations for Improvements with Future USCG Construction Tenders**

***Recommendation 3 — Consider exploring ways to provide additional work/storage space on deck and to use the available space most efficiently.*** The deck of a construction tender performing ATON operations is a congested and busy place, especially when many aids are being rebuilt/constructed during a single trip. Storage of materials for construction (e.g., piles) as well as wreckage consumes much of the available space. During construction activities, crew members, equipment, and the crane all interact in the limited space. A good layout and work flow pattern would help minimize the potential for this interaction to result in injuries and/or damage to the vessel/equipment. The what-if analysis team felt that future design efforts should focus on this key issue when planning vessel dimensions, storage locations, and work locations.

***Recommendation 4 — Consider investigating whether better methods are available for lifting steel piles, especially when they are wet/icy.*** Piles (wood or steel) are lifted by slings, which use friction (rather than a more positive fastener) to secure piles. Smooth steel piles (especially wet or icy piles) have lower coefficients of friction than wood piles and may be more prone to slip in a sling, which could cause personnel injury and/or vessel/equipment damage. Members of the *KENNEBEC* crew were not aware of problems using slings to lift dry steel piles, but were aware of at least one case where a wet/icy steel pile slipped from the sling connected to a cross-deck winch. The what-if analysis team believed that further investigation into best industry practices for lifting steel piles would be warranted.

***Recommendation 5 — Consider exploring ways to provide better access to aids from platforms on the vessel.*** Currently, removable extension platforms are laid from the deck to install features of aids such as identification signs, lights, batteries, etc. These platforms do not always provide

easy access to all sides of an aid, and a crew member could fall overboard if he/she loses his/her balance (especially if a crew member must reach far outside the platform or is using power tools). Better platform designs and/or changes in the deck design could provide better access to aids.

Tables C.3 and C.4 summarize the possible impacts of implementing each of the recommendations according to the deviations affected by each recommendation. Figure C.1 graphically illustrates the estimated range of savings expected to occur through implementing the recommendations.

### ***C.7 Observations/Conclusions***

Overall, the PHA results provided an excellent, high-level characterization of the types of mishaps associated with ATON operations. As expected, the what-if analyses refined the PHA results with some more detailed descriptions of specific causes of certain mishaps and additional recommendations for risk reduction. This analysis successfully accomplished the following:

- Confirmation that the PHA methodology was effective in regard to ATON operations
- Demonstration that more detailed hazard analysis can improve the effectiveness/quality of a PHA
- Generation of additional suggestions for reducing risks of ATON operations

The close correlation between the PHA results and the what-if analysis results was expected because of the PHA team's high level of confidence in their PHA risk characterizations. This simple, efficient what-if analysis has served as a valuable confirmation of the PHA team's work; a confirmation warranted because of the relatively high risk associated with ATON operations and (at least implicitly) accepted by the USCG.

Table C.2 What-If Analysis of KENNEBEC ATON Operations (Focusing on Deck Operations)

Drawings:

What if...?	Responses	Safeguards	Recommendations
1.1 a spud is inadvertently lowered or a spud mechanism fails when the vessel is underway	Equipment damage/loss: damage to the spud	Brakes set on spuds when underway Pins set on spuds when underway Ability to chain pins on spuds during severe weather	Multiple personnel on the deck and the bridge should notice spud lowering Annual cable replacement for the spud winches Crew members lower spuds only when commanded

1.2 a spud is inadvertently lowered or a spud mechanism fails while maneuvering the vessel for ATON operations

No consequences of interest because of low speed -- delay in attaining the desired location

**Table C.2 What-If Analysis of KENNEBEC ATON Operations (Focusing on Deck Operations)**

Drawings:

What if...?	Responses	Safeguards	Recommendations
1.3 a spud is inadvertently raised while performing ATON operations other than pile driving (including work on extended platforms)	Person overboard Collision with a fixed object	Multiple personnel on the deck and the bridge should notice spud raising Crew members raise spuds only when commanded Personnel on deck are required to wear flotation devices	
1.4 a spud is inadvertently raised while driving piles	Person overboard Collision with a fixed object Equipment damage/loss -- lead, driver, and crane damage	Multiple personnel on the deck and the bridge should notice spud raising Crew members raise spuds only when commanded Personnel on deck are required to wear flotation devices	
1.5 a spud is lowered onto an electrical cable	Hazardous exposure -- electrical shock	Location of electrical lines are marked on navigational maps	
1.6 a spud breaks	Equipment damage/loss Hazardous exposure -- contact injury from falling spud Collision with a fixed object	Four spuds available on the vessel Inspection of the spud welds	

Table C.2 What-If Analysis of KENNEBEC ATON Operations (Focusing on Deck Operations)

1 KENNEBEC ATON OPERATIONS

Drawings:

What if...?	Responses	Safeguards	Recommendations
1.7 the vessel collides with an aid during maneuvering	Collision with a fixed object	Spuds typically used during maneuvering to help control movement	
1.8 a pile is dropped while it is being lifted	Hazardous exposure -- contact injury from falling pile	Presence of multiple personnel on the bridge helps reduce the likelihood of conning errors Personnel on deck observing and directing vessel movement Crane inspection each day crane is used	4
1.9 a pile breaks while it is being driven	Hazardous exposure -- contact injury with pile fragments	Personnel stand clear of pile while it is raised Personnel observe progress of pile driving to detect fixity	
1.10 a pile swings excessively while it is being connected to the lead	Hazardous exposure -- contact injury Person overboard	Multiple personnel performing operation to maintain control of pile Personnel on deck are required to wear flotation devices	
1.11 a pile swings while it is being lifted	Hazardous exposure -- contact injury Person overboard	Use of cross-deck winch to control movement of pile while it is being lifted Only one person allowed on same side of vessel as the pile while it is being lifted Personnel on deck are required to wear flotation devices	

Table C.2 What-If Analysis of KENNEBEC ATON Operations (Focusing on Deck Operations)

Drawings:

What if...?	Responses	Safeguards	Recommendations
1.12 piles shift while personnel are climbing over them	Slip hazard Hazardous exposure -- contact injury	Paths around piles are generally available for use to help minimize need for climbing over piles	1
1.13 piles are slippery while personnel are climbing over them	Slip hazard	Paths around piles are generally available for use to help minimize need for climbing over piles	1
1.14 the pile driver fails to start	No consequences of interest -- it takes longer to drive a pile		
1.15 no hearing protection is worn	Hazardous exposure -- noise	Hearing protection is available for use, and is typically worn when steel piles are driven	
1.16 an aid is positioned improperly	No consequences of interest -- operability concern		
1.17 the seas are rough during ATON operations	Person overboard Collision with a fixed object	Use of spuds helps reduce vessel movement ATON operations are not attempted during high sea states	
1.18 a person loses balance when reaching for aid (e.g., while attaching aid to pile)	Person overboard	Personnel on deck are required to wear flotation devices Platforms are available to help access aid	5

Table C.2 What-If Analysis of KENNEBEC ATON Operations (Focusing on Deck Operations)

1 KENNEBEC ATON OPERATIONS

Drawings:

What if...?	Responses	Safeguards	Recommendations
1.19 a recovered aid (e.g., temporary buoy) swings excessively while it is being brought on board	Hazardous exposure -- contact injury Person overboard	Recovered aids are typically moved outside of the plane of the vessel deck until they are brought on board	
		Where possible, part of the aid (e.g., the sinker) is kept below the surface of the water while the aid is being moved	
		Personnel on deck are required to wear flotation devices	
1.20 the deck is cluttered with tools and/or recovered aids	Slip hazard Person overboard	Personnel are trained to keep walkways clear	
	Hazardous exposure -- contact injury	Personnel on deck are required to wear flotation devices	
1.21 the weather is hot	Hazardous exposure -- hot environment/surface/material	Ability to take breaks as needed (sufficient personnel available to minimize safety impacts of personnel taking a break)	
		Availability of liquids for consumption	
1.22 the weather is cold	Hazardous exposure -- cold environment/surface/material	Availability of cold weather gear (e.g., coveralls, gloves, floatation suits)	
		Availability to take breaks as needed (sufficient personnel available to minimize safety impacts of personnel taking breaks)	



**Table C.2 What-If Analysis of KENNEBEC ATON Operations (Focusing on Deck Operations)**

Drawings:

What if...?	Responses	Safeguards	Recommendations
1.23 a person is too near the crane when it is moved	Hazardous exposure -- contact injury	Exclusion area around crane marked	
1.24 the crane hits an overhead object	Equipment damage/loss Collision with a fixed object	Crane movement is relatively slow Multiple personnel on the deck and the bridge should notice overhead object	
1.25 the crane is lowered too quickly	Hazardous exposure -- contact injury (setting load on personnel) Equipment damage/loss	Crane operator certification program Crane inspection each day crane is used Personnel stand clear of a load while it is raised	
1.26 lightning strikes the vessel	Hazardous exposure -- shock hazard	ATON operations are not performed if lightning is in the area	
1.27 personnel are caught in/on/by/between equipment (winches, crane, piles being inserted in jigs, etc.)	Hazardous exposure -- contact injury	Crane winches are not accessible to personnel on the deck Guards are provided on spud winches	
1.28 a person falls while inspecting the crane	Hazardous exposure -- contact injury Person overboard		2

Table C.3 Estimated Impact of What-If Analysis Recommendations on Related PHA Deviations

Recommendations	Associated PHA Deviations	Initial Risk Index Number	Revised Risk Index Number	Certainty in Revised Risk Index Number	Notes
<p><i>Recommendation 1 — Consider ensuring that the operator for Spud #3 does not climb over the steel piles to man his/her station, especially when the steel piles are wet, icy, or unevenly stacked</i></p>	<p>Slip/trip/fall (while working aids to navigation) (Item 20.4 in Table A.1A)</p>	<p>7 (1,2)</p>	<p>7 (1,2)</p>	<p>Medium</p>	<p>Some risk reduction can be realized, but substantial slip/trip/fall potentials across the vessel will still exist</p>
<p><i>Recommendation 2 — Consider modifying the crane boom to provide grating within the structure of the boom as a walkway for the person conducting the daily crane inspection</i></p>	<p>Slip/trip/fall (All modes of operation and while working aids to navigation) (Item 20.4 in Table A.1A)</p>	<p>13 (2,3)</p>	<p>7 (1,2)</p>	<p>Medium</p>	<p>Physical grating reduces the chances of Class A/B mishaps more than Class C/D mishaps</p>

Table C.3 Estimated Impact of What-If Analysis Recommendations on Related PHA Deviations (cont'd)

Recommendations	Associated PHA Deviations	Initial Risk Index Number	Revised Risk Index Number	Certainty in Revised Risk Index Number	Notes
<p><i>Recommendation 3 — Consider exploring ways to provide additional work/storage space on deck and to use the available space most efficiently</i></p>	Slip/trip/fall (while working aids to navigation) (Item 20.4 in Table A.1A)	7 (1,2)	7 (1,2)	Medium	Some risk reduction can be realized, but substantial slip/trip/fall potentials across the vessel will still exist
	Struck by/contact by (Item 20.2 in Table A.1A)	8 (1,3)	7 (1,2)	Medium	
<p><i>Recommendation 4 — Consider investigating whether better methods are available for lifting steel piles, especially when they are wet/icy</i></p>	Lifting objects — Loss of support (Item 10.1 in Table A.1A)	18 (3,3)	12 (2,2)	Medium	Although a noticeable risk reduction can be achieved, other hazards associated with slippery wooden piles and mechanical malfunctions are still present
	Slip/trip/fall (while working aids to navigation) (Item 20.4 in Table A.1A)	7 (1,2)	7 (1,2)	Medium	Some risk reduction can be realized, but substantial slip/trip/fall potentials across the vessel will still exist

Table C.4 Estimated Impact of What-If Analysis Recommendations on the Risk Index Number of Related PHA Deviations

Deviation	PHA Recommendation(s)	Initial Risk Index Number	Revised Risk Index Number	Certainty in Revised Risk Index Number	Notes
Slip/trip/fall (while working aids to navigation) (Item 20.4 in Table A.1A)	<p><i>Recommendation 1 — Consider ensuring that the operator for Spud #3 does not climb over the steel piles to man his/her station, especially when the steel piles are wet, icy, or unevenly stacked</i></p>	7 (1,2)	6 (1,1)	Medium	Some risk reduction can be realized, but other slip/trip/fall potentials still exist on board
	<p><i>Recommendation 2 — Consider modifying the crane boom to provide grating within the structure of the boom as a walkway for the person conducting the daily crane inspection</i></p>				
	<p><i>Recommendation 3 — Consider exploring ways to provide additional work/storage space on deck and to use the available space most efficiently</i></p>				
	<p><i>Recommendation 5 — Consider exploring ways to provide better access to aids from platforms on the vessel</i></p>				

**Table C.4 Estimated Impact of What-If Analysis Recommendations on the Risk Index Number of Related PHA Deviations (cont'd)**

Deviation	PHA Recommendation(s)	Initial Risk Index Number	Revised Risk Index Number	Certainty in Revised Risk Index Number	Notes
Lifting objects — Loss of support (Item 10.1 in Table A.1A)	<i>Recommendation 4 — Consider investigating whether better methods are available for lifting steel piles, especially when they are wet/icy</i>	18 (3,3)	12 (2,2)	Medium	Although a noticeable risk reduction can be achieved, other hazards associated with slippery wooden piles and mechanical malfunctions are still present
Struck by/contact by (Item 20.2 in Table A.1A)	<i>Recommendation 3 — Consider exploring ways to provide additional work/storage space on deck and to use the available space most efficiently</i>	8 (1,3)	7 (1,2)	Low	Some risk reduction can be realized, but the hazard is not eliminated

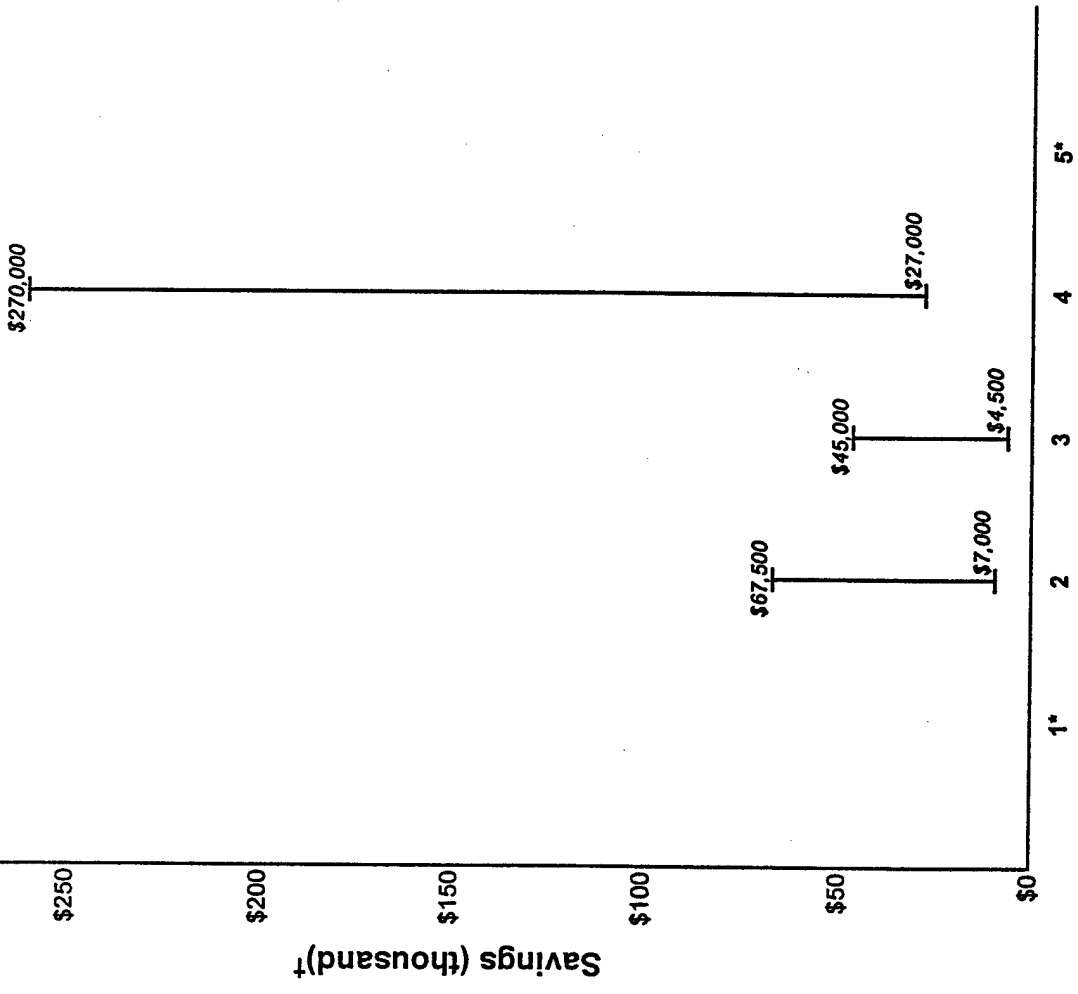

**Recommendations**

\*Though the recommendations were expected to significantly reduce risks, the change in risk is not expected to cause overall risk index numbers for the vessel to change.

†Savings estimate assumes Class A/B mishaps cost \$250,000 and Class C/D mishaps cost \$50,000.

**Figure C.1 Estimated Range in Dollar Savings Upon Implementing an ATON Recommendation for KENNEBEC**

## **Attachment F**

### ***Risk-based Safety Survey of a WHEC-378 Vessel***

This attachment contains the results of a risk-based safety survey performed on a Coast Guard vessel (WMEC-378). The results include findings from the survey, risk impact of the findings, and root cause analysis results of certain findings. This risk-based safety survey report format was generated to illustrate how results could be presented and is not meant to represent a Coast Guard standard. In implementing the IRA process, the Coast Guard will define standard reporting formats.

***INTEGRATED SAFETY ASSESSMENT (ISA) PROGRAM  
SAFETY SURVEY OF A  
WHEC-378 VESSEL***

This report serves as an example for documenting the results of risk-based safety surveys conducted as part of the USCG Integrated Safety Assessment (ISA) process. The formats presented in the report are designed to fit closely with those currently used by USCG health and safety professionals. The formats may change as the ISA process is assimilated into USCG operations.

The formats were developed assuming that USCG MLC and unit personnel (1) will be trained on the ISA process, (2) understand how safety surveys are planned and conducted, and (3) understand root cause analysis. When assessing root causes, a safety survey team (due to time considerations) may not conduct root cause analyses on all survey findings, but rather may select certain findings based on risk impacts of the findings and/or the judgment of the survey team (e.g., if it believes a finding indicates a larger problem with USCG management systems).

The information in this report came from an ISA safety survey testing effort. The test took place on board a WHEC-378 vessel during its regularly scheduled health and safety survey. Personnel from the MLC-Pacific Health and Safety Section conducted the safety survey and participated in the testing effort.



From: Commander, Maintenance and Logistics Command (Atlantic/Pacific)  
To: Commanding Officer, USCGC ANYCUTTER (WXXX-xxx)

Subj: SAFETY AND ENVIRONMENTAL HEALTH ASSISTANCE SURVEY

Ref: (a) Safety and Environmental Health Manual, COMDINST M5100.47  
(b) Health and Safety Support Program Guide, MLCLANT/PACINST MXXXX  
(c) Occupational Safety and Health Administration Regulation, 29 CFR 1910  
(d) Integrated Safety Assessment (ISA) User's Guide, COMDINST XXXX  
(e) Integrated Safety Assessment (ISA) Coarse Hazard Analysis of the WXXX-xxx Vessel Class  
(f) Cutter Safety Survey Schedule (MLC letter XXXX)

1. In accordance with references (a) through (d), a Safety and Environmental Health Assistance Survey of your unit was conducted on (Day-Month-Year) by CWO John Doe and HSCM John Smith. This report is divided into survey results and survey scope.
2. **Survey Results:** The survey produced no large safety concerns. The survey results are summarized in Enclosure 1, which presents (1) each finding's risk impact on the risk profile for your vessel [reference (e)], (2) possible root causes for selected findings, (3) suggested actions for correcting the findings and/or their root causes, and (4) the recommended command for addressing the findings. The root cause analysis was performed on selected findings to identify potential fleet management system deficiencies. MLC (k) will forward the survey results to the responsible commands (other than your unit) identified in Enclosure 1.

Enclosure 2 presents how the risk impact categories were determined for each survey finding. Considering the total impact of all the findings (the summed effect of the findings), the overall risk impact on your vessel due to the findings is Low. Of the survey findings that were evaluated, Finding 1 contributes the most to your unit's risk.

**Finding 1:** The walk-in refrigerator is not automatically maintaining temperature between 33 °F and 40 °F. Currently, the refrigerator is manually shut off when it gets too cold and is allowed to heat back up.

Please reply via the chain of command to MLCLANT/PAC (k) within 30 days indicating action taken or an action plan (including Current Ships Maintenance Projects [CSMPs]) to abate the findings as required by reference (a). Enclosure (1) of reference (a) and Chapter 3-D of reference (b) describe abatement plans.

3. **Survey Scope:** The visit was a level 1 survey, which was conducted according to your unit's safety survey schedule [reference (f)]. Enclosure 3 outlines the scope of this survey and lists the applicable checklist questions. Enclosure 3 was sent to your unit for reference prior to the survey. The next safety survey of your unit, according to reference (f), is tentatively scheduled as a level 3 survey, which will focus only on High risk importance checklist questions. The MLC health and safety staff will answer any questions concerning your unit's next scheduled survey.
4. My point of contact in this matter is CWO John Doe.

X. XXXXX  
By direction

Encl:

- (1) Results from the (Day-Month-Year) Safety Survey for USCGC ANYCUTTER
- (2) Risk Impact of Safety Survey Findings from the (Day-Month-Year) Safety Survey for USCGC ANYCUTTER
- (3) Safety Survey Scope

Copy

xxxxx  
yyyyy

Findings from the (Day-Month-Year) Safety Survey for USCGC ANYCUTTER (Survey Team: CWO John Doe, HSCM John Smith)

Finding	Risk Significance	Possible Root Cause(s)	Suggested Actions	Responsibility
1. The walk-in refrigerator is not automatically maintaining temperature between 33 °F and 40 °F. Currently, the refrigerator is manually shut off when it gets too cold and is allowed to heat back up	Low	Not evaluated'	The walk-in refrigerator should be repaired to maintain a temperature between 33 °F and 40 °F	Unit
2. The walk-in freezer gasket is not adjusted properly and allows ice buildup around the door. This indicates that the inside food materials may not be maintained in a frozen condition	Very Low	Not evaluated'	Adjust or replace the walk-in freezer gasket to prevent ice buildup around the door	Unit
3. The reach-in freezer is maintaining a temperature of 20 °F, not 0 °F. Ship's practice is not to maintain food items in this freezer for long	Very Low	Not evaluated'	The reach-in freezer should be adjusted or repaired to maintain a temperature of 0 °F or below	Unit
4. Permanently assigned food handlers are not receiving 6 hours of annual food service sanitization training. However, onboard training and current food handling practices do address the topics in the annual training	Very Low	Not evaluated'	Ensure 6 hours of annual food service sanitization training is administered to food handlers	Unit
5. A few nonblue hoses with no stenciling are being used for potable water service. However, the hoses are segregated from other hoses and are believed to be used correctly by the crew	Very Low	Not evaluated'	Stencil all potable water hoses every 10 feet with "Potable Water Only" and ensure the hoses are colored blue	Unit
6. Potable water hoses are not consistently coupled when stored. This is not considered a significant issue since the hoses are segregated from other hoses and are believed to be used correctly by the crew	Very Low	Not evaluated'	Couple potable water hose connections when stored	Unit

Findings from the (Day-Month-Year) Safety Survey for USCGC ANYCUTTER (Survey Team: CWO John Doe, HSCM John Smith)  
(cont'd)

Finding	Risk Significance	Possible Root Cause(s)	Suggested Actions	Responsibility
7. The potable water air gap in the helicopter wash down system is not two times the diameter of the supply line. This is a potential potable water cross-contamination issue, though not a large issue	Very Low	Not evaluated <sup>1</sup>	Repair the potable water air gap in the helicopter wash down system so that it is two times the diameter of the supply line	Unit
8. Flex extension cords are being used to power fixed equipment. The cords are acceptable for temporary power needs, but are not suitable for long-term use. This was found in the Boatswains Cage	Very Low	Not evaluated <sup>1</sup>	Discontinue the use of flex extension cords as normal power source wiring and install permanent wiring if needed	Unit
9. Flex extension cords for stereo equipment are being used in the machine shop (cord runs in the overhead and through the bulkhead). The cords are acceptable for temporary power needs, but are not suitable for long-term use. This was found in the Boatswains Cage	Very Low	Not evaluated <sup>1</sup>	Discontinue the use of flex extension cords as normal power source wiring and install permanent wiring if needed	Unit
10. Respiratory fit records are incomplete. The types of respirators, the fit tester, and the fit test method are not recorded	Not evaluated <sup>2</sup>	Responsibility for the item/activity may not be adequately defined Training requirements may not be identified	Promulgate written USCG instructions outlining the training necessary to administer a respirator program	MLC (v) MLC (k)
11. The Hazard Communication instruction does not require the Hazardous Material Control Officer to review purchase requests of HAZMAT. Unauthorized HAZMAT may be accidentally brought on board	Not evaluated <sup>2</sup>	Not evaluated <sup>1</sup>	Update the vessel's Hazard Communication instruction to include review of HAZMAT purchase requests by the Hazardous Material Control Officer	Unit

Findings from the (Day-Month-Year) Safety Survey for USCGC ANYCUTTER (Survey Team: CWO John Doe, HSCM John Smith)  
(cont'd)

Finding	Risk Significance	Possible Root Cause(s)	Suggested Actions	Responsibility
<p>12. The HAZMAT inventory list does not include manufacturers' names and addresses. This makes it difficult to ensure that accurate material safety data sheets are on board or that contact is made with manufacturers for information on chemical properties of materials</p>	<p>Not evaluated<sup>2</sup></p>	<p>Not evaluated<sup>1</sup></p>	<p>Update the HAZMAT inventory list to include manufacturers' names and addresses</p>	<p>Unit</p>
<p>13. Hazardous materials are incorrectly placed into the flammable storage lockers, and some materials are in damaged containers. This can lead to spilling HAZMAT or mixing incompatible materials</p>	<p>Not evaluated<sup>2</sup></p>	<p>Not evaluated<sup>1</sup></p>	<p>Remove the hazardous materials in the flammable storage locker and transfer them into an undamaged container</p>	<p>Unit</p>
<p>14. No expiration date is indicated on the personal eyewash units in the 1C Gyro space and EM shop. The water in the units may become contaminated if not periodically changed out</p>	<p>Not evaluated<sup>2</sup></p>	<p>Not evaluated<sup>1</sup></p>	<p>Check the water in the personal eyewash stations units for contamination, and place an expiration date on the units or replace the units (ensure expiration dates are on the new units)</p>	<p>Unit</p>
<p>15. Protective caps are not installed on the nozzles for the emergency eyewash stations in the engine room. Foreign material may get inside the eyewash bottle and further aggravate an eye condition when it is used</p>	<p>Not evaluated<sup>2</sup></p>	<p>Not evaluated<sup>1</sup></p>	<p>Inspect and flush the emergency eyewash stations in the engine room and install protective caps on the nozzles</p>	<p>Unit</p>
<p>16. The ventilation system in the forward pump room was not operating when the survey team entered the space. A fuel odor was present, which may be an explosive or asphyxiation hazard</p>	<p>Not evaluated<sup>2</sup></p>	<p>Not evaluated<sup>1</sup></p>	<p>Ensure that the ventilation system in the forward pump room is operable prior to entry</p>	<p>Unit</p>

Findings from the (Day-Month-Year) Safety Survey for USCGC ANYCUTTER (Survey Team: CWO John Doe, HSCM John Smith)  
(cont'd)

Finding	Risk Significance	Possible Root Cause(s)	Suggested Actions	Responsibility
17. Not all flammable storage containers have appropriate labels. This may lead to spilling a flammable substance or using it improperly	Not evaluated <sup>3</sup>	Not evaluated <sup>1</sup>	Properly label all flammable storage containers	Unit
18. The chain falls in the Damage Control Repair 2 locker have not been weight tested. Undetected degradation of the chain falls may affect the ability to support a suspended load	Not evaluated <sup>2</sup>	Responsibility for the item/activity may not be adequately defined	Assign responsibility for inspection, test, and maintenance of chain falls to a vessel division	Unit
19. The forward sewage pump room has no posted placard stating "No eating, drinking, or smoking in this space." This warning decreases the chances of spreading contaminants	Not evaluated <sup>3</sup>	Not evaluated <sup>1</sup>	Require and conduct chain fall inspection, test, and maintenance in accordance with 29 CFR 1910.179 (j), (k), and (l)  Place a placard in the forward sewage pump room that states "No eating, drinking, or smoking in this space"	Unit MLC (v) MLC (k)
20. No protective cover exists on top of the drill press in the machine shop. The cover serves as a guard against physical harm to the operator	Not evaluated <sup>2</sup>	Not evaluated <sup>1</sup>	Install a protective cover on top of the drill press in the machine shop	Unit
21. The safety switches to the service hoist in the galley are inoperable, allowing hoist operation without the doors being fully closed. Crew members may accidentally catch their hands/arms inside the hoist while operating it	Not evaluated <sup>2</sup>	Enforcement of the vessel's tagout instruction may need improvement	Tagout the service hoist in the galley  Conduct tagout training for vessel food service personnel  Consider design alternatives for bringing food materials to the galley if the dumbwaiter malfunctions	Unit  Unit  MLC (v)

Findings from the (Day-Month-Year) Safety Survey for USCGC ANYCUTTER (Survey Team: CWO John Doe, HSCM John Smith)  
(cont'd)

Finding	Risk Significance	Possible Root Cause(s)	Suggested Actions	Responsibility
22. No pull chains are installed on the steam relief valves on the steam kettles in the galley. This allows manual pressure relief instead of relying only on automatic relief protection	Not evaluated <sup>2</sup>	Not evaluated <sup>1</sup>	Install pull chains on the steam relief valves on the steam kettles in the galley	Unit

<sup>1</sup> A root cause analysis was not performed on this finding during the safety survey test application

<sup>2</sup> The applicable section of the WXXX-xxx coarse hazard analysis was not evaluated due to time constraints

<sup>3</sup> This type of finding would normally be assessed for risk impact, but was not during the safety survey test application

**Risk Impact of Safety Survey Findings from the (Day-Month-Year) Safety Survey for USCGC ANYCUTTER  
(Survey Team: CWO John Doe, HSCM John Smith)**

Finding	EP <sup>1</sup>	Affected Operation/Evolution	Baseline and Revised Frequency Scores <sup>2</sup>		Risk Index Number <sup>2</sup>	Change in Risk Index	Risk Impact
			A/B	C/D			
1	H011	Not operation/evolution specific <i>Providing food services</i> Improper storage of food	2 (3)	5 (5)	0.303 (0.330)	0.027	Low
2	H011	Not operation/evolution specific <i>Providing food services</i> Improper storage of food	2 (2)	5 (5)	0.303 (0.303)	0	Very Low
3	H011	Not operation/evolution specific <i>Providing food services</i> Improper storage of food	2 (2)	5 (5)	0.303 (0.303)	0	Very Low
4	H043	Not operation/evolution specific <i>Providing food services</i> Improper dispensing/cleanup of food and food service areas	1 (1)	5 (5)	0.3003 (0.3003)	0	Very Low
		Not operation/evolution specific <i>Providing food services</i> Improper storage of food	2 (2)	5 (5)	0.303 (0.303)	0	Very Low
		Not operation/evolution specific <i>Providing food services</i> Improper preparation of food	3 (3)	5 (5)	0.330 (0.330)	0	Very Low
<b>Cumulative Change in the Risk Index Results for This Finding</b>							
5	G002	Not operation/evolution specific <i>Providing potable water services</i> Contamination of potable water	3 (3)	3 (3)	0.033 (0.033)	0	Very Low
6	G003	Not operation/evolution specific <i>Providing potable water services</i> Contamination of potable water	3 (3)	3 (3)	0.033 (0.033)	0	Very Low



**Risk Impact of Safety Survey Findings from the (Day-Month-Year) Safety Survey for USCGC ANYCUTTER  
(Survey Team: CWO John Doe, HSCM John Smith) (cont'd)**

Finding	EP <sup>1</sup>	Affected Operation/Evolution	Baseline and Revised Frequency Scores <sup>2</sup>		Risk Index Number <sup>3</sup>	Change in Risk Index	Risk Impact
			A/B	C/D			
7	G006	Not operation/evolution specific <i>Providing potable water services</i> Contamination of potable water	3 (3)	3 (3)	0.033 (0.033)	0	Very Low
8	K?? <sup>3</sup>	Not operation/evolution specific <i>Controlling/generating/distributing electrical energy</i> Electrical fault/short	2 (2)	3 (3)	0.006 (0.006)	0	Very Low
9	K?? <sup>3</sup>	Not operation/evolution specific <i>Controlling/generating/distributing electrical energy</i> Electrical fault/short	2 (2)	3 (3)	0.006 (0.006)	0	Very Low
10	E004	Not operation/evolution specific <i>Storing/handling asphyxiants</i> No/inadequate personal protective equipment (PPE) for expected contact with asphyxiants <sup>4</sup> Not operation/evolution specific <i>Storing/handling toxic/corrosive/reactive material</i> No/inadequate PPE for routine contact with toxic/corrosive material <sup>4</sup>					

**Risk Impact of Safety Survey Findings from the (Day-Month-Year) Safety Survey for USCGC ANYCUTTER  
(Survey Team: CWO John Doe, HSCM John Smith) (cont'd)**

Finding	EP <sup>1</sup>	Affected Operation/Evolution	Baseline and Revised Frequency Scores <sup>2</sup>		Risk Index Number <sup>3</sup>	Change in Risk Index	Risk Impact
			A/B	C/D			
11	L006	Not operation/evolution specific <i>Storing/handling toxic/corrosive/reactive material</i> Failing to adequately prepare equipment/space containing toxic/corrosive material for entry <sup>4</sup>					
		Not operation/evolution specific <i>Storing/handling toxic/corrosive/reactive material</i> Mixing incompatible materials <sup>4</sup>					
		Not operation/evolution specific <i>Storing/handling toxic/corrosive/reactive material</i> Failing to adequately prepare equipment/space containing toxic/corrosive material for entry <sup>4</sup>					
12	L001	Not operation/evolution specific <i>Storing/handling toxic/corrosive/reactive material</i> Mixing incompatible materials <sup>4</sup>					
		Not operation/evolution specific <i>Storing/handling toxic/corrosive/reactive material</i> Failing to adequately prepare equipment/space containing toxic/corrosive material for entry <sup>4</sup>					
13	L004	Not operation/evolution specific <i>Storing/handling toxic/corrosive/reactive material</i> Mixing incompatible materials <sup>4</sup>					
		Not operation/evolution specific <i>Storing/handling toxic/corrosive/reactive material</i> Spill/release of toxic/corrosive material <sup>4</sup>					

**Risk Impact of Safety Survey Findings from the (Day-Month-Year) Safety Survey for USCGC ANYCUTTER  
(Survey Team: CWO John Doe, HSCM John Smith) (cont'd)**

Finding	Ep <sup>1</sup>	Affected Operation/Evolution	Baseline and Revised Frequency Scores <sup>2</sup>		Risk Index Number <sup>2</sup>	Change in Risk Index	Risk Impact
			A/B	C/D			
14	D007	Not operation/evolution specific <i>Storing/handling toxic/corrosive materials</i> Spill/release of toxic/corrosive material <sup>4</sup>					
		Not operation/evolution specific <i>Storing/handling toxic/corrosive materials</i> No/inadequate PPE for routine contact with toxic/corrosive material <sup>4</sup>					
15	D006	Not operation/evolution specific <i>Storing/handling toxic/corrosive materials</i> Spill/release of toxic/corrosive material <sup>4</sup>					
		Not operation/evolution specific <i>Storing/handling toxic/corrosive materials</i> No/inadequate PPE for routine contact with toxic/corrosive material <sup>4</sup>					
16	U018	Not operation/evolution specific <i>Storing/handling asphyxiants</i> Accumulation of asphyxiants in vessel spaces <sup>4</sup>					
		Not operation/evolution specific <i>Storing/handling flammable/combustible materials</i> Spill of bulk combustible materials <sup>5</sup>	3	4	0.06		
17	M?? <sup>3</sup>	Not operation/evolution specific <i>Storing/handling flammable/combustible materials</i> Spill of maintenance and general usage flammable/combustible liquids <sup>5</sup>	1	3	0.003003		
18	N?? <sup>3</sup>	Not operation/evolution specific <i>Lifting/lowering/transferring objects</i> Loss of support <sup>4</sup>					

**Risk Impact of Safety Survey Findings from the (Day-Month-Year) Safety Survey for USCGC ANYCUTTER  
(Survey Team: CWO John Doe, HSCM John Smith) (cont'd)**

Finding	EP <sup>1</sup>	Affected Operation/Evolution	Baseline and Revised Frequency Scores <sup>2</sup>		Risk Index Number <sup>3</sup>	Change in Risk Index	Risk Impact
			A/B	C/D			
19	I001	Not operation/evolution specific <i>Providing sewage handling services</i> Spill/leak/rupture of sewage/sewage handling system <sup>5</sup>	1	5	0.3003		
20	S010	Not operation/evolution specific <i>Controlling exposure to medical infection from people/work environments</i> Contamination from workspace equipment/objects carrying disease <sup>4</sup>					
21	H?? <sup>3</sup>	Not operation/evolution specific <i>Controlling exposure to physical hazards</i> Caught in/on/by/between <sup>4</sup>					
22	H027	Not operation/evolution specific <i>Controlling exposure to hot/cold surfaces/materials</i> Release of hot materials <sup>4</sup>					

<sup>1</sup> Evaluation point (checklist item)

<sup>2</sup> Values in parentheses are revised risk estimates based on the impact of the finding. The baseline frequency scores are for an individual vessel and were derived from the frequency scores for the WXXX-xxx vessel class

<sup>3</sup> Finding is applicable to the listed checklist section, but no specific question exists for this condition

<sup>4</sup> The listed deviation was not evaluated in the WXXX-xxx coarse hazard analysis due to time constraints

<sup>5</sup> This type of finding would normally be assessed for risk impact, but was not during the safety survey test application

## **Safety Survey Scope**

The safety survey was level 1, which assesses all evaluation points (checklist items) regardless of their risk importance. Level 1 surveys are conducted periodically to ensure that all evaluation points are reviewed (per unit) at some minimum frequency.

*Note: Actual USCG reports would list all evaluation points assessed during the survey (the entire checklist in the case of a level 1 survey). This includes evaluation point descriptions and references. The list should be sent to the unit prior to the survey visit to allow time for preparation. Also included here is an example scope for a level 2 survey for demonstration purposes. The scope documents other reasons for adding evaluation points to the survey scope, and should also be sent to the unit along with the advance copy of the applicable evaluation points.*

**ENCLOSURE (3)**

**Example Scope for a Level 2 Survey**

<b>Date of Assessment:</b>	<b>Unit:</b>	<b>Unit Phone Number:</b>
<b>Assessment Level: 2</b>	<b>CO/OIC:</b>	<b>OPFAC Number:</b>
	<b>XO/XPO:</b>	<b>Team Leader:</b>
	<b>Safety Coordinator: E-mail Address:</b>	<b>Team Members:</b>
<b>Evaluation Area</b>	<b>Evaluation Points*</b>	<b>Justification and Comments</b>
Occupational Medical Monitoring Program	A1, A2, A3, A5, A6, A10, A11, A13	Checking these items due to recent change of command
Heat Stress Program	B1, B2, B5, B6, B8, B9, B10	
Hearing Protection	C1, C2, C3, C4, C5, C6, C7, C8, C9, C10, C11, C12	
Eye Protection	D1, D5, D6, D7, D8, D9	
Respiratory Protection	E1, E2, E6, E9, E10, E11, E12	Checking these items due to mishaps listed in recent message traffic
Asbestos	F1, F2, F3, F4, F5, F6, F7, F8, F9, F10	
Potable Water	G1, G2, G3, G4, G6, G7, G9, G10, G11, G12	
Food Preparation Spaces	H1, H2, H3, H4, H5, H6, H7, H10, H11, H13, H14, H15, H17, H20, H22, H23, H24, H28	
Safety Program Administration	J1, J2, J3, J4, J5, J6, J7, J8, J9, J10, J11, J12, J13, J14, J15, J16	Checking these items due to request from Unit CO
Electrical Safety	K1, K4, K5, K6, K7, K9, K10, K11, K12, K13, K16, K17, K19, K20, K22, K33, K35, K38, K39, K41, K42, K44	

\* Evaluation points are from the health and safety checklist promulgated by USCG Headquarters (G-WKS-4)