

DEVELOPING A HANDBOOK FOR CONSTRUCTION
EQUIPMENT MANAGEMENT AND
IMPLEMENTATION

By

RUSSELL V. SEIGNIOUS

A REPORT PRESENTED TO THE GRADUATE COMMITTEE OF THE
DEPARTMENT OF CIVIL ENGINEERING IN PARTIAL FULFILLMENT OF THE
REQUIREMENTS FOR THE DEGREE OF MASTER OF ENGINEERING

UNIVERSITY OF FLORIDA

SUMMER 1999

DISTRIBUTION STATEMENT A:
Approved for Public Release -
Distribution Unlimited

DTIC QUALITY INSPECTED 4

19990827 101

Table of contents

1. INTRODUCTION	1
2. EQUIPMENT ECONOMICS	2
2.1. TIME VALUE OF MONEY	2
2.2. COMPOUND INTEREST FACTORS	2
2.2.1. <i>Single Payment Factors</i>	3
2.2.2. <i>Uniform Series Factors</i>	3
2.3. DEPRECIATION TECHNIQUES	6
2.3.1. <i>Straight Line</i>	6
2.3.2. <i>Sum Of the Years Digit</i>	7
2.3.3. <i>Declining Balance</i>	8
3. COST OF EQUIPMENT	11
3.1. ELEMENTS OF EQUIPMENT COST	11
3.2. OWNERSHIP COSTS	11
3.2.1. <i>Amortized Method</i>	12
3.2.2. <i>Average Annual Investment Method</i>	13
3.3. OPERATING COSTS	15
3.3.1. <i>Fuel Costs</i>	15
3.3.2. <i>Lubrication Costs</i>	16
3.3.3. <i>Repair Costs</i>	16
3.3.4. <i>Tire Costs</i>	17
3.3.5. <i>Special Items</i>	17
3.3.6. <i>Operators Wages</i>	18
3.4. SOURCES OF TABULATED EQUIPMENT COSTS	19
3.4.1. <i>Army Corps of Engineers</i>	19
3.4.2. <i>Rental Rate Blue Book</i>	20
4. SOIL PROPERTIES AND HANDLING	21
4.1. SOIL CONDITIONS	21
4.1.1. <i>Bank Measure</i>	21
4.1.2. <i>Loose Measure</i>	21
4.1.3. <i>Compacted Measure</i>	21
4.2. SOIL SWELL	22
4.3. SOIL SHRINKAGE	22
4.4. LOAD AND SHRINKAGE FACTORS	23
4.5. SPOIL BANKS	24
5. PRODUCTIVITY	27
6. EXCAVATING EQUIPMENT	29
6.1. SHOVELS	29
6.2. BACKHOES	32
6.3. DRAGLINES	36
7. TRACTORS/DOZERS	40
8. LOADERS	44
9. HAULING EQUIPMENT	48

9.1. ROLLING RESISTANCE.....	48
9.2. GRADE RESISTANCE.....	49
9.3. EFFECTIVE GRADE.....	49
9.4. SCRAPERS.....	49
9.5. PUSH LOADING.....	55
9.6. TRUCKS.....	59
10. EQUIPMENT SELECTION.....	61
10.1. LINE OF BALANCE.....	61
11. REFERENCES.....	65
APPENDIX A - COMPOUND INTEREST TABLES.....	66

1. Introduction

Construction equipment may constitute one of the single largest long term capital investments for a contractor. This is particularly true for those contractors engaged primarily in horizontal construction. Regardless of the type of construction, the goal of successful construction management is to complete projects in accordance with plans and specifications, on time, within budget, and at the least possible cost. A crucial element in accomplishing the aforementioned goal is the effective management and implementation of construction equipment.

The fundamental goal of the equipment management process is to determine the best piece of equipment for a given job. Although this is not necessarily a complex notion, there are many factors to consider in making this determination. Most importantly, the equipment must pay for itself. In other words, the cost to own and operate the equipment must be less than what the equipment owner charges for its use. Today there exist many different types of equipment that can accomplish the same job. Thus, the equipment manager must typically consider more than one option.

Inefficient management of equipment can result in low production and/or idle equipment; either of which can impact project duration and cost. Therefore, it is important for contractors, construction managers, project managers, and any person directly responsible for equipment management to be familiar with the methods leading to selection of the appropriate equipment for a given job.

Not only is it important for equipment managers to be familiar with this subject, it is also important for project owners, contract administrators, and others responsible for representing the project owner. By being familiar with equipment cost formulation, the owner's representative can more easily identify an inappropriate charge on a contract action.

What this report sets forth to provide is a clear and concise handbook for the equipment management process. It provides a basic overview of the subject and will allow the reader to develop a construction equipment management process based on his or her own set of criteria.

2. Equipment Economics

2.1. Time Value of Money

It is an accepted fact that the value of money varies over time. Simply put, one dollar today will have more buying power than one dollar ten years from today. Similarly, one dollar deposited in an interest bearing savings account will grow to some value greater than one dollar in the future. Because the value of money changes over time, it is important for equipment managers to consider this time value of money when making decisions on different equipment options. By reviewing the economic impacts of each option the equipment manager can ensure the least expensive option is chosen. He does this by developing equivalence models for each option. Equivalence is a concept that looks at the value of two different options and determines the equivalent value of each option based on interest and number of payments. For example, \$1,000 is deposited in an account earning 10% per year, so the value of that account at the end of the first year will be \$1,100. Therefore, it is said that \$1,000 today is equivalent to \$1,100 one year from today, provided the interest rate is 10%.

2.2. Compound Interest Factors

Compound interest factors are obtained from simple mathematical formulas. These factors provide a simple means for analyzing economic alternatives to determine equivalence. Most economic texts have tables with compound interest factors in tabulated form. Appendix 1 of this report contains compound interest tables for convenience.

The following notations will be used in the compound interest factors to be discussed subsequently:

- P = The present value of a sum of money. For example: equipment purchase price, loan amount, down payment etc.
- A = A uniform series of end of period payments. Loan payments are an example.
- F = A future sum of money.
- n = The number of interest periods.
- i = The interest rate per period.

2.2.1. Single Payment Factors

Single payment factors are used to compare single present values to single future values and visa versa.

2.2.1.1. Single Payment Compound Amount Factor

The single payment compound amount factor is used to obtain the future value of a present sum of money based on an interest rate i and a number of interest periods n , where:

$$F = P \times (1 + i)^n$$

and $(1 + i)^n$ is the single payment compound amount factor. The functional notation for this factor is $(F/P, i, n)$, and these factors can be found tabulated in Appendix 1.

Example 2-1

A contractor purchased a grader for \$250,000 today. The contractor expects to purchase another grader in 5 years. The contractor assumes that annual inflation will be 6%. How much will the same grader cost in 5 years?

Solution

$$\begin{aligned} \text{From Appendix 1, } (F/P, 6\%, 5) &= 1.3382 \\ \text{Grader Cost in 5 years} &= 1.3382 \times \$250,000 = \underline{\$334,550} \end{aligned}$$

2.2.1.2. Single Payment Present Worth Factor

The single payment present worth factor is used to obtain the present value of a future sum of money based on an interest rate i and a number of interest periods n , where:

$$P = F \times (1 + i)^{-n}$$

and $(1 + i)^{-n}$ is the single payment present worth factor. The functional notation for this factor is $(P/F, i, n)$, and these factors can be found tabulated in Appendix 1.

Example 2-2

The contractor assumes the grader in example 2-1 will need a replacement blade in 3 years. The blade is expected to cost \$3000 in 3 years. The contractor feels he can earn 8% interest on investments. How much will the contractor need to invest today in order to accumulate \$3000 in 3 years based on 8% interest?

Solution

$$\begin{aligned} \text{From Appendix 1, } (P/F, 8\%, 3) &= 0.7938 \\ \text{Investment needed} &= 0.7938 \times \$3,000 = \underline{\$2381.40} \end{aligned}$$

2.2.2. Uniform Series Factors

Uniform series factors are used to determine what a known uniform series of payments future or present value will be. They are also used to determine what value of uniform payment will result in a known present or future sum of money.

2.2.2.1. Uniform Series Capital Recovery Factor

The uniform series capital recovery factor is used to obtain the series of equal payments that are equal to a known present sum of money based on an interest rate i and a number of interest periods n , where:

$$A = P \times [i(1+i)^n]/[(1+i)^n - 1]$$

and $[i(1+i)^n]/[(1+i)^n - 1]$ is the uniform series capital recovery factor. The functional notation for this factor is $(A/P, i, n)$, and these factors can be found tabulated in Appendix 1.

Example 2-3

A contractor has found a used tractor with a price of \$25,000. The contractor wishes to finance this purchase. The bank offers a 5 year loan at 12% interest compounded annually with the payments due at the end of each year. What will the contractor's annual payments be?

Solution

$$\begin{aligned} \text{From Appendix 1, } (A/P, 5, 12\%) &= 0.2774 \\ \text{Five annual payments} &= 0.2774 \times \$25,000 = \underline{\$6,935} \end{aligned}$$

2.2.2.2. Uniform Series Present Worth Factor

The uniform series present worth factor is used to obtain the present worth of a series of known payments based on an interest rate i and a number of interest periods n , where:

$$P = A \times [(1+i)^n - 1]/[i(1+i)^n]$$

and $[(1+i)^n - 1]/[i(1+i)^n]$ is the uniform series present worth factor. The functional notation for this factor is $(P/A, i, n)$, and these factors can be found tabulated in Appendix 1.

2.2.2.3. Uniform Series Sinking Fund Factor

The uniform series sinking fund factor is used to obtain the uniform series of investments required to accumulate a desired future sum of money based on an interest rate i and a number of interest periods n , where:

$$A = F \times i / [(1 + i)^n - 1]$$

and $i / [(1 + i)^n - 1]$ is the uniform series sinking fund factor. The functional notation for this factor is $(A/F, i, n)$, and these factors can be found tabulated in Appendix 1.

Example 2-4

A contractor is attempting to plan ahead by making annual investments, which will be used to accumulate money for the future purchase of a piece of equipment. The piece of equipment is anticipated to cost \$500,000 and will be needed 10 years from today. The contractor elects to make annual contributions to a fixed income type investment, which earns 5% interest compounded annually. What will the contractor's required annual contribution be?

Solution

$$\begin{aligned} \text{From Appendix 1, } (A/F, 5\%, 10) &= 0.0795 \\ \text{Ten annual contributions} &= 0.0795 \times \$500,000 = \underline{\underline{\$39,750}} \end{aligned}$$

2.2.2.4. Uniform Series Compound Amount Factor

The uniform series compound amount factor is used to obtain the future worth of a series of equal payments based on an interest rate i and a number of interest periods n , where:

$$F = A \times [(1 + i)^n - 1] / i$$

and $[(1 + i)^n - 1] / i$ is the uniform series compound amount factor. The functional notation for this factor is $(F/A, i, n)$, and these factors can be found tabulated in Appendix 1.

2.3. Depreciation Techniques

Depreciation is defined by the Bureau of Internal Revenue code as "a reasonable allowance for the exhaustion, wear and tear of property used in the trade or business, including a reasonable allowance for obsolescence."^(2-2*6) There are two reasons for

depreciating equipment. The first reason is to establish you tax liability, and the second reason is to determine the depreciation component of an equipment cost. It is legal to use two different methods of depreciation for the two different reasons. Often owners will elect to use the fastest depreciation technique, thus reducing the tax liability more quickly over the first few years of an equipment's useful life. However, if the equipment is sold for more than its depreciated book value, the excess will be treated as ordinary income and taxed accordingly.

There are several methods of depreciation recognized by the Internal Revenue Service. Three of the methods typically used for construction equipment are discussed in detail subsequently. A graphical comparison of three of these methods is shown in Figure 2-1.

2.3.1. Straight Line

The straight line method of depreciation results in equal annual depreciation amounts. The following formula is used to calculate straight line depreciation:

$$D_n = \frac{\text{Initial Cost} - \text{Salvage Value}}{N}$$

Where D_n = Depreciation for year in question
 N = Equipment life in years

Example 2-5

Using straight line depreciation calculate the depreciation for a piece of equipment with a purchase price of \$120,000 and an expected salvage value of \$18,000. The equipment is expected to have a life of 8 years. Provide tabulated results.

Solution

$$D_{1,2\dots 8} = \frac{\$120,000 - \$18,000}{8}$$

$$D_n = \underline{\$12,750}$$

Year	Beginning Value	Depreciation	End of Year Book Value
1	\$120,000	\$12,750	\$107,250
2	\$107,250	\$12,750	\$94,500
3	\$94,500	\$12,750	\$81,750
4	\$81,750	\$12,750	\$69,000
5	\$69,000	\$12,750	\$56,250
6	\$56,250	\$12,750	\$43,500
7	\$43,500	\$12,750	\$30,750
8	\$30,750	\$12,750	\$18,000

2.3.2. Sum Of the Years Digit

The sum of the years digit method of depreciation produces non-uniform depreciation, with the largest amount of depreciation occurring in the first few years of depreciation. The depreciation amount is calculated by multiplying the total amount of depreciation (Initial Cost - Salvage Value) by a depreciation factor. The depreciation factor is obtained by taking the year number, in reverse order, and dividing by the sum of the number of years in the depreciation cycle. The following are the formulas for obtaining the depreciation factors for the sum of the years digit method:

$$D_f(\text{year 1}) = n \div (1 + 2 + \dots + n)$$

$$D_f(\text{year 2}) = n-1 \div (1 + 2 + \dots + n)$$

$$D_f(\text{year 3}) = n-2 \div (1 + 2 + \dots + n)$$

$$D_f(\text{year n}) = 1 \div (1 + 2 + \dots + n)$$

Where D_f = Depreciation factor for year being considered
 n = Number of years in depreciation cycle

Example 2-6

Using the same information from Example 2-5 calculate depreciation using the sum of the years digit method and tabulate results.

Solution

$$\begin{aligned} D_f(\text{year 1}) &= 8 \div 36 = 0.2222 & D_f(\text{year 5}) &= 4 \div 36 = 0.1111 \\ D_f(\text{year 2}) &= 7 \div 36 = 0.1944 & D_f(\text{year 6}) &= 3 \div 36 = 0.0833 \\ D_f(\text{year 3}) &= 6 \div 36 = 0.1667 & D_f(\text{year 7}) &= 2 \div 36 = 0.0556 \\ D_f(\text{year 4}) &= 5 \div 36 = 0.1389 & D_f(\text{year 8}) &= 1 \div 36 = 0.0278 \\ D_n &= D_f \times (\text{Total Depreciation}) = D_f \times \$102,000.00 \end{aligned}$$

Year	Beginning Value	Depreciation Factor	Depreciation	End of Year Book Value
1	\$120,000.00	0.2222	\$22,664.40	\$97,335.60
2	\$97,335.60	0.1944	\$19,828.80	\$77,506.80
3	\$77,506.80	0.1667	\$17,003.40	\$60,503.40
4	\$60,503.40	0.1389	\$14,167.80	\$46,335.60
5	\$46,335.60	0.1111	\$11,332.20	\$35,003.40
6	\$35,003.40	0.0833	\$8,496.60	\$26,506.80
7	\$26,506.80	0.0556	\$5,671.20	\$20,835.60
8	\$20,835.60	0.0278	\$2,835.60	\$18,000.00

2.3.3. Declining Balance

The declining balance method of depreciation is similar to the sum of the years digit method in that the highest levels of depreciation occur in the first few years of depreciation. Unlike the sum of the years digit method, when using the declining balance method, the depreciation amount for a given year is obtained by multiplying the book value at the beginning of the year being considered by a depreciation factor. Depreciation factors for declining balance depreciation are obtained from the following formula:

$$D_f = DB_f \div N$$

- Where** D_f = Depreciation factor
 DB_f = Declining Balance Factor (2 = Double Declining, 3 = Triple Declining, 4 = Quadruple Declining, etc.)
 N = Number of years in depreciation cycle

Although any declining balance factor can, in theory, be used for calculating declining balance depreciation, the most common factor is the double declining balance factor.

Example 2-7

Using the same information from Example 2-5 calculate depreciation using double declining balance and tabulate results.

Solution

$$D_f = 2 \div 8 = \underline{0.25}$$

$$D_n = D_f \times \text{Years Beginning Value}$$

Year	Beginning Value	Depreciation Factor	Depreciation	End of Year Book Value
1	\$120,000.00	.25	\$30,000.00	\$90,000.00
2	\$90,000.00	.25	\$22,500.00	\$67,500.00
3	\$67,500.00	.25	\$16,875.00	\$50,625.00
4	\$50,625.00	.25	\$12,656.25	\$37,968.75
5	\$37,968.75	.25	\$9,492.19	\$28,476.56
6	\$28,476.56	.25	\$7,119.14	\$21,357.42
7	\$21,357.42	.25	\$3,357.42*	\$18,000.00
8	\$18,000.00	.25	\$0.00*	\$18,000.00

*Note: In year 7 the depreciation by calculation is \$5,339.36, however, you can not reduce the book value below that of the given \$18,000.00. Therefore, the depreciation amount in year 7 and 8 are reduced accordingly.

Figure 2-1
Comparison of Depreciation Methods

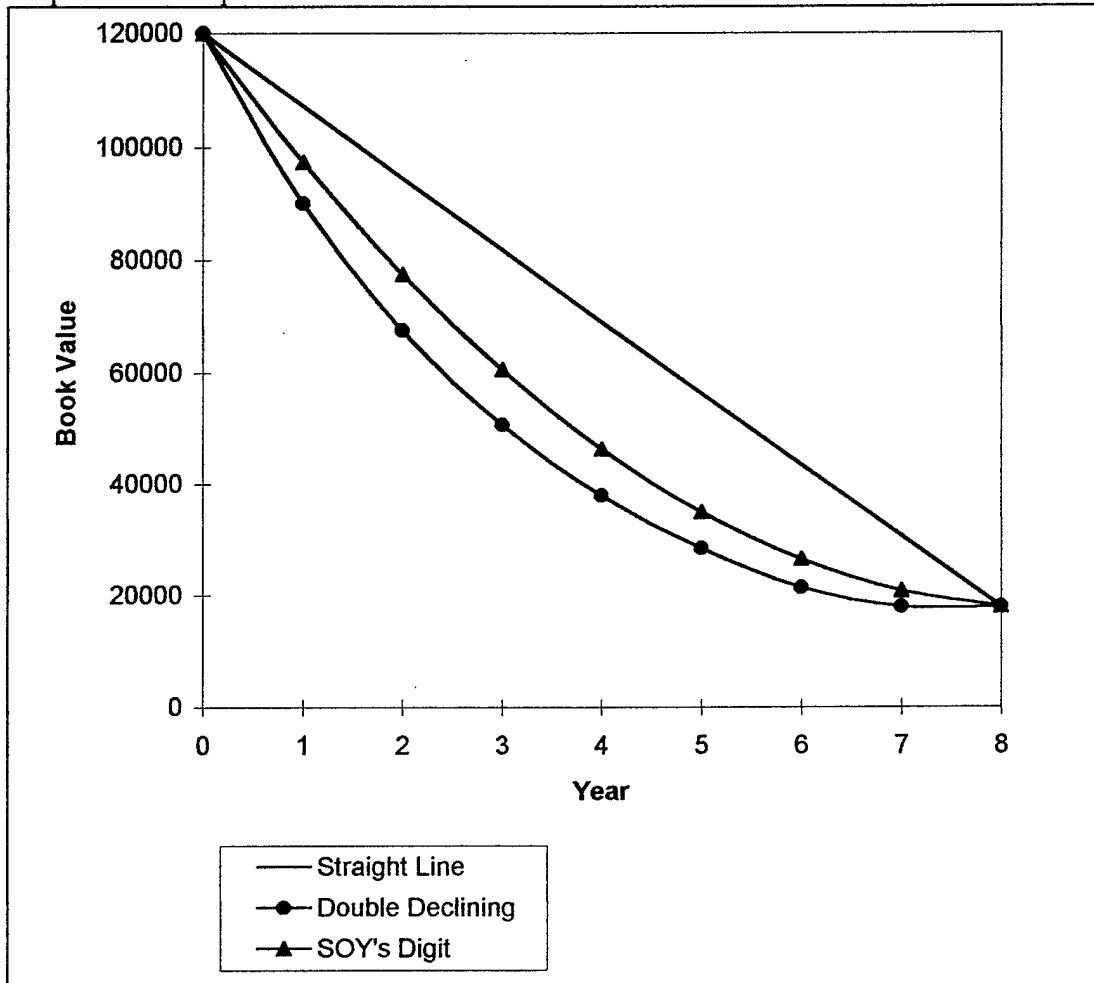

3. Cost of Equipment

3.1. Elements of Equipment Cost

There are two basic elements of equipment cost. These two elements are *ownership costs* and *operating costs*. It is understood that your equipment must pay for itself, therefore it is imperative that equipment owners accurately calculate ownership and operating costs for their equipment. By accurately calculating these costs, the equipment owner can confidently assign a cost that will result in the equipment being profitable.

Generally, ownership and operating costs are calculated based on an hourly rate. The reason for calculating these costs on an hourly basis is because that is how they are normally billed on construction projects.

3.2. Ownership Costs

Ownership costs are those costs which the owner will incur regardless of whether the equipment is used or not. Typical ownership costs are listed below.

- Depreciation
- Interest (Investment, Cost of Capital)
- Insurance
- Taxes
- Storage

The owner accounts for depreciation by knowing the purchase price and estimating a salvage value and equipment useful life. The remaining items: interest, insurance, taxes, and storage will be used to develop a *minimum attractive rate of return*. Minimum attractive rate of return will be detailed in a subsequent example.

Interest is the cost resulting from borrowed money. The equipment owner should account for this cost even if money is not borrowed, as the cash used to purchase the equipment will no longer be available to earn interest in a savings or investment vehicle. Insurance costs are for liability and equipment damage protection. Taxes covers those costs associated with personal property taxes. Storage costs are for those times when the equipment is not employed on a job.

As discussed previously, an equipment owner will need to make an estimate on a piece of equipment's useful life in order to calculate depreciation. One of the more common means of estimating useful life is through the use of tables provided by manufactures. Table 3-1 is an example of the type of table a manufacturer might provide.

Table 3-1
Estimated Useful Life of Construction Equipment (Total Operating Hours)

Equipment	Operating Conditions		
	Favorable	Average	Unfavorable
Crawler tractor	15,000	12,000	10,000
Grader	20,000	15,000	12,000
Excavator	15,000	12,000	10,000
Hauler	25,000	20,000	15,000
Scraper	16,000	12,000	10,000
Tracked loader	10,000	8,000	6,000
Wheeled loader	12,000	10,000	8,000

Data for this table was extracted from *Reference 6, p. 27*

Two methods of calculating ownership costs will be detailed here. The first method uses the principles of equipment economics covered earlier, and is known as the *Amortized Method*. The second method is an approximate method known as the *Average Annual Investment Method*. An example of each method is detailed in the following problems.

3.2.1. Amortized Method

The following example describes the method for obtaining a piece of equipment's ownership cost by the amortized method.

Example 3-1

A contractor purchases a scraper for \$150,000 and estimates it will be used 2000 hrs each year and will have a salvage value at the end of its useful life of about 10% of purchase price. The contractor figures his ownership cost factors as:

- *Interest* 8%
- *Insurance* 2%
- *Taxes* 1%
- *Storage* 1%

What will the contractor's hourly ownership cost (C_{own}) be for the scraper described above for favorable conditions?

Solution

Step 1 - Calculate period of ownership

$$\text{ownership period} = \text{estimated useful life} \div \text{yearly usage} = 16,000 \text{ hrs} \div 2000 \text{ hrs/yr}$$

$$\text{Ownership period} = 8 \text{ years}$$

Step 2 - Calculate minimum attractive rate of return (MARR)

$$\text{MARR} = \text{Interest} + \text{Insurance} + \text{Taxes} + \text{Storage} = 8\% + 2\% + 1\% + 1\%$$

$$\text{MARR} = 12\%$$

Step 3 - Calculate the present value (PV) of the salvage value

$$\text{salvage value} = 0.10 \times \$150,000 = \$15,000$$

$$(P/F, 12\%, 8) = 0.4039$$

$$\text{PV of salvage} = 0.4039 \times \$15,000$$

$$\text{PV of salvage} = \$6,058.50$$

Step 4 - Calculate the total present value of the scraper

$$\text{Total present value} = \text{Initial Cost} - \text{PV of salvage} = \$150,000 - \$6,058.50$$

$$\text{Total present value} = \$143,941.50$$

Step 5 - Calculate the annual ownership cost of the scraper

$$\text{Annual Ownership Cost} = \text{Total Present Value} \times (A/P, 12\%, 8)$$

$$\text{Annual Ownership Cost} = \$143,941.50 \times 0.2013$$

$$\text{Annual Ownership Cost} = \$28,975.42$$

Step 6 - Calculate hourly ownership cost (C_{own})

$$C_{own} = \text{Annual Ownership Cost} \div \text{Annual hourly usage} = \$28,975.42 \div 2,000 \text{ hrs/yr}$$

$$C_{own} = \underline{\underline{\$14.49/hr}}$$

The hourly ownership cost obtained in this example represents the total hourly rate to cover all of the ownership costs associated with this scraper.

3.2.2. Average Annual Investment Method

Another method for determining ownership costs is known as the average investment method. This method is an approximation, and should only be used for useful life periods of less than ten years. The formula for calculating average annual investment follows:

$$\text{If no salvage: } P_{avg} = P(N + 1) \div 2N$$

$$\text{If Salvage is to be included: } P_{avg} = [P(N + 1) + S(N - 1)] \div 2N$$

Where P_{avg} = average annual investment
 P = initial equipment cost

- N = useful life in years
S = salvage value

To obtain the investment cost (C_{inv}) based on the average annual investment you multiply P_{avg} by the minimum attractive rate of return (MARR).

$$C_{inv} = P_{avg} \times MARR$$

This method does not account for the cost of depreciation (C_{dep}), so it must be added separately to obtain the total ownership cost.

$$C_{own} = C_{dep} + C_{inv}$$

The following example illustrates the details of obtaining ownership costs based on the average annual investment method.

Example 3-2

Calculate the hourly ownership cost (C_{own}) for the scraper described in Example 3-1 using the Average Annual Investment Method. All conditions remain the same.

Solution

Step 1 - Calculate the average annual investment (P_{avg})

$$P_{avg} = [P(N + 1) + S(N - 1)] \div 2N = [\$150,000(8 + 1) + \$15,000(8 - 1)] \div 2(8)$$

$$P_{avg} = \$90,937.50$$

Step 2 - Calculate investment cost (C_{inv})

$$C_{inv} = P_{avg} \times MAAR = \$90,937.50 \times 12\%$$

$$C_{inv} = \$10,912.50/yr \div 2000hrs/yr = \$5.46/hr$$

$$C_{inv} = \$5.46/hr$$

Step 3 - Calculate depreciation cost (C_{dep})

$$C_{dep} = (\text{Initial Purchase Price} - \text{Salvage Value}) \div \text{estimated useful life}$$

$$C_{dep} = (\$150,000 - \$15,000) \div 16000hrs$$

$$C_{dep} = \$8.44/hr$$

Step 4 - Calculate the hourly ownership cost (C_{own})

$$C_{own} = C_{dep} + C_{inv} = \$8.44/hr + \$5.46/hr$$

$$C_{own} = \underline{\underline{\$13.90/hr}}$$

The results of examples 3-1 and 3-2 show that these two methods differ only slightly in the end result. That being the case, it should still be noted that the amortized method is the more accurate of the two methods.

3.3. Operating Costs

Operating costs are those costs that are incurred only when the equipment is in use. One of the best sources for obtaining operating costs is historical data. Most equipment manufacturers provide tables of adjustment factors to aid equipment owners in estimating equipment operating costs. The following is a list of those items that are generally considered operating costs.

- Fuel Costs
- Lubrication Costs
- Repair Costs
- Tire Costs
- Special Items
- Operators Wages

The sum of these individual costs will represent the total operating cost of a piece of equipment, and the sum of the total operating cost and total ownership cost will represent the total equipment cost.

$$\text{Total Equipment Cost} = \text{Total Ownership Costs} + \text{Total Operating Costs}$$

3.3.1. Fuel Costs

The cost of fuel will be obtained by multiplying a given piece of equipment's hourly fuel burn in gallons per hour by the cost of fuel in dollars per gallon. A load factor is usually applied to the basic fuel burn. Table 3-2 is an example of a fuel consumption load factor table. Hourly fuel burn will be provided with most manufactures equipment performance data. However, if fuel burn is unavailable the hourly fuel burn can be estimated with the following formulas:

Gasoline Engines

$$Q = (0.7 \times \text{hp} \times \text{load factor}) \div 6.2\text{gph}$$

Diesel Engines

$$Q = (0.5 \times \text{hp} \times \text{load factor}) \div 7.2\text{gph}$$

Where Q = Fuel Burn (gallons per hour)

hp = Equipment Horsepower

Table 3-2
Load Factors for Fuel Consumption

Equipment	Operating Conditions		
	Favorable	Average	Severe
Wheel Type, on pavement	0.25	0.30	0.40
Wheel Type, off pavement	0.50	0.55	0.60
Tracked Crawler	0.50	0.63	0.75
Power Excavator	0.50	0.55	0.60

Data for this table was extracted from *Reference 1, p. 33*

Example 3-3

What would the estimated hourly cost of fuel be for a 30 horsepower diesel wheel type loader used off road if the cost of diesel is \$1.25/gallon and operating conditions are average?

Solution

Step 1 - Calculate hourly fuel burn (Q)

$$Q = (0.5 \times \text{hp} \times \text{load factor}) \div 7.2\text{gph} = (0.5 \times 30 \times 0.55) \div 7.2\text{gph}$$

$$Q = 1.14 \text{ gph}$$

Step 2 - Calculate fuel cost per hour (C_{fuel})

$$C_{\text{fuel}} = Q \times \text{Cost of fuel per gallon} = 1.14\text{gph} \times \$1.25/\text{gallon}$$

$$C_{\text{fuel}} = \underline{\underline{\$1.42/\text{hr}}}$$

3.3.2. Lubrication Costs

Lubrication costs are those costs associated with equipment lubrication, hydraulic fluids, oil filters, grease, etc.. Lubrication costs are best estimated from historical data. Once enough historical data is obtained you can reduce lubrication costs to a percentage of fuel costs.

3.3.3. Repair Costs

Repair costs are those cost associated with other than routine maintenance and tires. Again, repair costs are best estimated from historical real data.

3.3.4. Tire Costs

Tire costs is not a negligible cost when it comes to heavy equipment. Replacing four tires on a loader might cost upwards of \$10,000. Hence, tire costs is an operating cost element all its own. Tire life will vary widely based on the operating conditions, therefore tire costs is somewhat difficult to estimate. As mentioned previously, historical data is the best method for estimating tire life and costs. However, there are various tables available for estimating tire life. Table 3-3 is an example of a tire life estimating aid. Tire repair will add about 15% to tire replacement cost.⁽³⁻⁴⁹⁴⁾ The following equation can be used to estimate tire cost:

$$\text{Tire Cost (\$/hr)} = (\text{Cost of set of tires}) \div (\text{Estimated tire life})$$

Table 3-3
Typical Tire Life (hrs)

Equipment	Operating Conditions		
	Favorable	Average	Severe
Dozers and loaders	3,200	2,100	1,300
Motor graders	5,000	3,200	1,900
Scrapers			
Conventional	4,600	3,300	2,500
Twin Engine	4,000	3,000	2,300
Push-pull and elevating	3,600	2,700	2,100
Trucks and wagons	3,500	2,100	1,100

Data for this table was extracted from *Reference 3, p. 494*

3.3.5. Special Items

Special items represents the cost associated with high-wear items. Examples of these type of items include, but are not limited to, scraper blade cutting edges and ripper tips. Hourly costs for these items are calculated by simply dividing the cost of the item by the expected life of the item.

3.3.6. Operators Wages

The last item to be included in the operating cost of a piece of equipment is the operator's wages. Some equipment may require a second laborer to serve as a spotter or oiler, and their wages should be included as well.

Example 3-4

A contractor wishes to calculate the total hourly ownership and operating cost for a diesel powered wheeled loader. Based on the following information, calculate the loader's total ownership and operating cost (use the amortized method for ownership cost calculation):

<i>Initial purchase price</i>	=	\$110,000
<i>Estimated salvage value</i>	=	\$15,000
<i>Operating conditions</i>	=	Favorable
<i>Estimated annual usage</i>	=	2000hrs
<i>MARR</i>	=	15%
<i>Rated horsepower</i>	=	400hp
<i>Lubrication</i>	=	10% of Fuel Cost
<i>Repairs (lifetime of equipment)</i>	=	30% of initial purchase price
<i>Tires (off road usage)</i>	=	\$8,000 (set)
<i>Special Items</i>	=	None
<i>Operator</i>	=	\$16.00/hr
<i>Diesel fuel</i>	=	\$1.05/gal

Ownership Costs

Step 1 - Calculate ownership period

$$\text{Ownership period} = 12,000\text{hrs} \div 2000\text{hrs/yr}$$

$$\text{Ownership period} = 6 \text{ years}$$

Step 2 - Calculate total present value (PV) of loader

$$PV = \text{Initial Purchase} - [\text{Salvage} \times (P/F, 15\%, 6)]$$

$$PV = \$110,000 - (\$15,000 \times 0.4323)$$

$$PV = \$103,515.50$$

Step 3 - Calculate the hourly ownership cost (C_{own})

$$C_{own} = \text{Annual Ownership Cost} \div \text{Annual usage}$$

$$C_{own} = [\$103,515.50 \times (A/P, 15\%, 6)] \div 2000\text{hrs}$$

$$C_{own} = (\$103,515.50 \times 0.2642) \div 2000\text{hrs}$$

$$C_{own} = \$13.67/\text{hr}$$

Operating Cost

Step 1 - Calculate hourly fuel cost (C_{fuel})

$$Q = (0.5 \times 400\text{hp} \times .25) \div 7.2\text{gph}$$

$$Q = 6.94\text{gph}$$

$$C_{fuel} = 6.94gph \times \$1.05/gal$$

$$C_{fuel} = \$7.29/hr$$

Step 2 - Calculate hourly lubrication cost (C_{lube})

$$C_{lube} = 0.10 \times \$7.29/hr = \$0.73/hr$$

Step 3 - Calculate hourly repair cost (C_{rep})

$$C_{rep} = (0.30 \times \$110,000) \div 15,000hrs$$

$$C_{rep} = \$2.20/hr$$

Step 4 - Calculate hourly tire cost (C_{tire})

$$C_{tire} = \$8,000 / 3,200hrs$$

$$C_{tire} = \$2.50/hr$$

Step 5 - Calculate hourly operator wages (C_{wage})

$$C_{wage} = \$16.00/hr$$

Step 6 - Calculate total operating cost (C_{oper})

$$C_{oper} = C_{fuel} + C_{lube} + C_{rep} + C_{tire} + C_{wage}$$

$$C_{oper} = \$7.29 + \$0.73 + \$2.20 + \$2.50 + \$16.00$$

$$C_{oper} = \$28.72/hr$$

$$\text{Total equipment cost} = C_{own} + C_{oper} = \$13.67 + \$28.72 = \underline{\underline{\$42.39/hr}}$$

3.4. Sources of Tabulated Equipment Costs

There are several sources of tabulated equipment costs that equipment owners or managers can use to obtain estimates of equipment ownership and operating costs. Two sources that will be briefly discussed here, are the Army Corps of Engineers Construction Equipment Ownership and Operating Expense Schedule and the Rental Rate Blue Book. These two publications use different methods for obtaining their respective ownership and operating costs. Thus, the rates in each will generally differ to some extent.

3.4.1. Army Corps of Engineers

The Army Corps of Engineers Construction Equipment Ownership and Operating Expense Schedule is published primarily for the use of government contracting agencies as a guide to verifying and estimating contractor equipment charges on government projects. This schedule attempts to represent, as realistically as possible, actual ownership and operating costs. A review of this book reveals that the Army applies a discount to the list price of equipment. This discount ranges from 7.5 % to 15% of list price. It is generally

accepted that contractors will receive some form of discount on equipment purchases, and the Army attempts to reflect this in calculating the ownership portion of an equipment's cost. The Army Corps of Engineers Construction Equipment Ownership and Operating Expense Schedule considers all those ownership and operating costs discussed previously in this report with the exception of operator's wages.

3.4.2. Rental Rate Blue Book

The Rental Rate Blue Book is published by Dataquest Incorporated. This book is also a source of estimated ownership and operating cost for equipment. This publication is somewhat conservative in comparison to the Army Corps of Engineers Construction Equipment Ownership and Operating Expense Schedule, as evidenced by the fact the manufacture's suggested list price is used in calculating the ownership cost of a piece of equipment. In using the manufactures suggested list price, the resulting ownership cost will typically be somewhat higher than what a contractor might actually incur in owning a piece of equipment. As with the Army Corps of Engineers Construction Equipment Ownership and Operating Expense Schedule, each of the ownership and operating costs discussed previously in this report are considered in the Rental Rate Blue Book's calculation of ownership and operating costs with the exception of operator's wages.

4. Soil Properties and Handling

Heavy equipment in the construction industry is primarily employed in the excavation, hauling, stabilization, loading, placing, grading, and finishing of material in the earth's crust. This material consists primarily of soil and rock. Soil possesses some unique characteristics that must be considered in selecting equipment that will most efficiently carryout these tasks. Therefore, it is important that the equipment manager have a basic understanding of these characteristics.

4.1. Soil Conditions

Earthmoving material can be measured in three primary states. These states include:

- Bank Measure
- Loose Measure
- Compacted Measure

4.1.1. Bank Measure

Bank measure represents the volume of a soil before being disturbed. This is also sometimes referred to as in-place or in-situ. This measure will typically be abbreviated as BCY or BCM for bank cubic yard and bank cubic meter respectively.

4.1.2. Loose Measure

Loose measure represents the volume of a disturbed soil, or one that has been excavated or loaded. This measure will typically be abbreviated as LCY or LCM for loose cubic yard and loose cubic meter respectively.

4.1.3. Compacted Measure

Compacted measure represents the volume of a soil after it has been placed and compacted. This measure will typically be abbreviated as CCY or CCM for compacted cubic yard and compacted cubic meter respectively.

Figure 4-1, Typical Volume Change During Earthmoving
 (Extracted from *Reference 3, p. 30*)

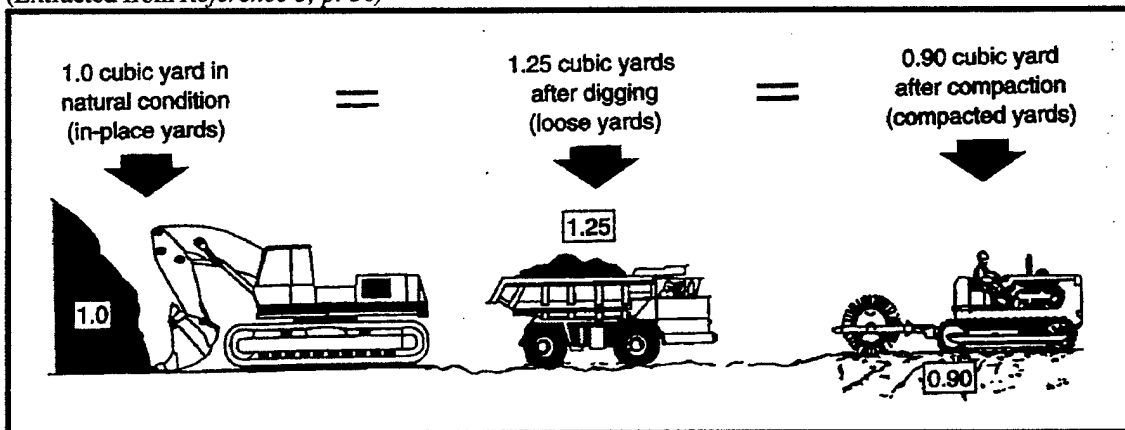

4.2. Soil Swell

When soil is excavated the particles become loose and voids are created. Thus, the volume of an excavated soil will be greater than that of the in-situ soil. This phenomenon is known as swell and is illustrated in Figure 4-1. The percentage of swell can be calculated from the following formula:

$$\text{Swell (\%)} = [(\text{Bank Unit Weight} \div \text{Loose Unit Weight}) - 1] \times 100$$

Example 4-1

Find the swell of a soil with an in-situ unit weight of 3,000 lb/cy and a 2,200 lb/cy unit weight after excavation:

$$\text{Swell} = [(3,000 \div 2,200) - 1] \times 100 = \underline{36\%}$$

That is, 1 bank cubic yard (BCY) of this material will equal 1.36 loose cubic yards (LCY).

4.3. Soil Shrinkage

When soil is compacted those voids developed during excavation and hauling are eliminated. In fact, the soil becomes even more dense than in its in-situ state. This phenomenon is known as shrinkage. The percentage of shrinkage can be calculated from the following formula:

$$\text{Shrinkage (\%)} = [1 - (\text{Bank Unit Weight} \div \text{Compacted Unit Weight})] \times 100$$

Example 4-2

Find the shrinkage of a soil with an in-situ unit weight of 2,800 lb/cy and a 3,500 lb/cy unit weight after compaction:

$$\text{Shrinkage} = [1 - (2,800 \div 3,500)] \times 100 = \underline{20\%}$$

That is, 1 bank cubic yard (BCY) of this material will equal 0.80 compacted cubic yards (CCY).

4.4. Load and Shrinkage Factors

It is often desirable to express earthmoving measures in a consistent measure, often bank measure. Therefore, load and shrinkage factors were developed to make converting between the three measures easier.

Haul units are often expressed in loose measure, therefore it is convenient to have a factor for converting loose measure to bank measure. This factor is known as the load factor and is expressed as follows:

$$\text{Load Factor} = \text{Loose Unit Weight} \div \text{Bank Unit Weight}$$

or

$$\text{Load Factor} = 1 \div (1 + \text{swell})$$

and

$$\text{Load Factor} \times \text{Loose Measure} = \text{Bank Measure}$$

A factor was also developed for converting bank measure to compacted measure, and is known as the shrinkage factor. This factor is expressed as follows:

$$\text{Shrinkage Factor} = \text{Bank Unit Weight} \div \text{Compacted Unit Weight}$$

or

$$\text{Shrinkage Factor} = 1 - \text{Shrinkage}$$

and

$$\text{Shrinkage Factor} \times \text{Bank Measure} = \text{Compacted Measure}$$

Some typical soil volume characteristics, with respect to earthmoving operations, are provided in Table 4-1.

Example 4-3

A soil has the following unit weights: 2,000 lb/LCY, 2,700 lb/BCY, and 3,400 lb/CCY. (a) What is the load factor and shrinkage factor for this soil? (b) How many BCY's and CCY's will there be in 500,000 LCY's of this soil?

Solution

(a)

$$\text{Load Factor} = 2,000 \div 2,700 = \underline{0.74}$$

$$\text{Shrinkage Factor} = 2,700 \div 3,400 = \underline{0.79}$$

(b)

$$0.74 \times 500,000 \text{ LCY} = \underline{370,000 \text{ BCY}}$$

$$0.79 \times 370,000 \text{ BCY} = \underline{292,300 \text{ CCY}}$$

Table 4-1
Typical Soil Volume Change Characteristics*

	Unit Weight (lb/cy)			Swell (%)	Shrinkage (%)	Load Factor	Shrinkage Factor
	Loose	Bank	Compacted				
Clay	2310	3000	3750	30	20	0.77	0.80
Common Earth	2480	3100	3450	25	10	0.80	0.90
Rock (blasted)	3060	4600	3550	50	-30**	0.67	1.30**
Sand and Gravel	2860	3200	3650	12	12	0.89	0.88

*Exact Values vary with grain size distribution, moisture, compaction, and other factors. Tests are required to determine exact values for a specific soil.

**Compacted rock, unlike soil, is less dense than in-place rock.

Data for this table was extracted from Reference 3, p. 33

4.5. Spoil Banks

It is often necessary to stockpile excavated material when performing earthmoving operations. As a result, one must be able to determine the size of the expected stockpile in order to determine an acceptable location for the stockpile. Stockpiled material can either be in the form of a *spoil bank* or *spoil pile*. Spoil banks are triangular in cross section and relatively long. Spoil piles are created when material is deposited from a fixed position, and they are conical in shape. The size of a spoil bank or pile is governed by the spoil material's angle of repose. Angle of repose is the angle measured from horizontal that the sides of a spoil bank or pile will naturally form when deposited. Table 4-2 list some common values for soil angle of repose.

Triangular Spoil Banks

$$\text{Volume} = \text{Section Area} \times \text{Length}$$

$$B = [(4V) \div (L \times \tan R)]^{1/2}$$

$$H = (B \times \tan R) \div 2$$

Where B = base width
 H = pile height
 L = pile length
 R = angle of repose (deg)
 V = pile volume

Conical Spoil Piles

$$\text{Volume} = 1/3 \times \text{Base area} \times \text{Height}$$

$$D = [(7.64V) \div (\tan R)]^{1/3}$$

$$H = (D \div 2) \times \tan R$$

Where D = Diameter of pile base

Table 4-2
 Typical Values For Excavated Soil Angle of Repose

Material	Angle of Repose (deg)
Clay	35
Common earth, dry	32
Common earth, moist	37
Gravel	35
Sand, dry	25
Sand, moist	37

Data for this table was extracted from *Reference 3, p. 34*

Example 4-4

Find the base width and height of a spoil bank containing 100,000 BCY of material. The length of the bank is 500 feet, and the material is clay.

Solution

From Table 4-1 Swell for Clay = 30%

From Table 4-2 Angle of repose for clay = 35°

Step 1 - Calculate Loose Volume

$$\text{Loose Volume} = 1.3 \times 100,000 \text{ BCY} \times 27 \text{ ft}^3/\text{yd}^3 = \underline{\underline{3,510,000 \text{ ft}^3}}$$

Step 2 - Calculate Base Width

$$\text{Base Width} = [(4 \times 3,510,000) \div (500 \times \tan 35^\circ)]^{1/2}$$

$$\text{Base Width} = \underline{\underline{200 \text{ feet}}}$$

Step 3 - Calculate Height

$$\text{Height} = (200 \times \tan 35^\circ) \div 2$$

$$\text{Height} = \underline{70 \text{ feet}}$$

Example 4-4

Find the base diameter and height of a spoil pile containing 200 BCY of dry sand.

Solution

From Table 4-1 Swell for sand = 12%

From Table 4-2 Angle of repose for dry sand = 25°

Step 1 - Calculate Loose Volume

$$\text{Loose Volume} = 1.12 \times 200 \times 27 \text{ ft}^3/\text{yd}^3 = \underline{6,048 \text{ ft}^3}$$

Step 2 - Calculate Base Diameter

$$\text{Base Diameter} = [(7.64 \times 6,048) \div (\tan 25^\circ)]^{1/3}$$

$$\text{Base Diameter} = \underline{46 \text{ feet}}$$

Step 3 - Calculate Height

$$\text{Height} = (46 \div 2) \times \tan 25^\circ$$

$$\text{Height} = \underline{10.7 \text{ feet}}$$

5. Productivity

The production of any particular earthmoving operation consists of the following elements:

- Loading
- Hauling
- Dumping
- Return
- Spot

Most of these terms are self explanatory with the possible exception of spot. Spot represents the time necessary for a haul unit to maneuver into position for loading. These elements represent the total production of a particular earthmoving activity. To calculate the total production you must first be able to calculate the production of each individual piece of equipment involved in the operation. The production of a piece of equipment is based on cycle time and volumetric capacity of the equipment. Cycle time is the time required of a given piece of equipment to complete one cycle of its intended operation. Production can be calculated as:

$$\text{Production} = \text{volume per cycle} \times \text{cycles per hour} \times \text{efficiency factor}$$

Because it is not possible to operate a piece of equipment at 100% efficiency, the production is reduced by some efficiency factor. There are two ways of estimating an efficiency factor. One method is to estimate the number of working minutes per hour, 50 minutes per hour or 0.833 is popular. The second method uses information obtained from tables similar to Table 5-1. Regardless of the method used, efficiency is effected by management conditions and job conditions.

Management Conditions Include:

- worker skill, training, and motivation
- selection, operation, and maintenance of equipment
- planning, job layout, supervision, and coordination

Job Conditions Include:

- topography and work dimensions
- surface and weather conditions
- work methods or sequence

Table 5-1
Efficiency Factors For Earthmoving Operations

Job Conditions	Management Conditions			
	Excellent	Good	Fair	Poor
Excellent	0.84	0.81	0.76	0.70
Good	0.78	0.75	0.71	0.65
Fair	0.72	0.69	0.65	0.60
Poor	0.63	0.61	0.57	0.52

Data for this table was extracted from *Reference 3, p. 23*

6. Excavating Equipment

Excavating equipment consists of those machines designed with the primary purpose of digging. The primary members of the excavating family include hydraulic excavators, hydraulic backhoes, and the family of cable operated crane digging devices (shovels, draglines, hoes, and clamshells). Although dozers, scrapers, and loaders can perform excavating activities, excavation is not their primary function, and they will not be considered members of the excavating equipment family here.

6.1. Shovels

Shovels dig in much the same fashion as a person would dig with a hand shovel. The operation of the shovel is forward and usually the bucket provides for bottom dumping. An illustration of the front shovel's components is shown in Figure 6-1. The first shovels were cable operated crane devices, however, these have almost completely been replaced by hydraulic shovels, as shown in Figure 6-2.

Figure 6-1
Front Shovel Components
(Extracted from *Reference 3, p. 50*)

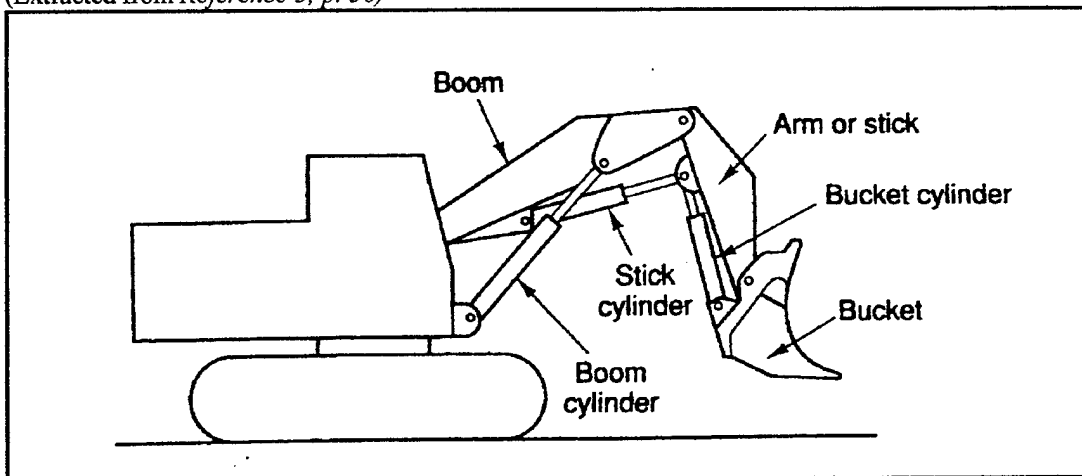
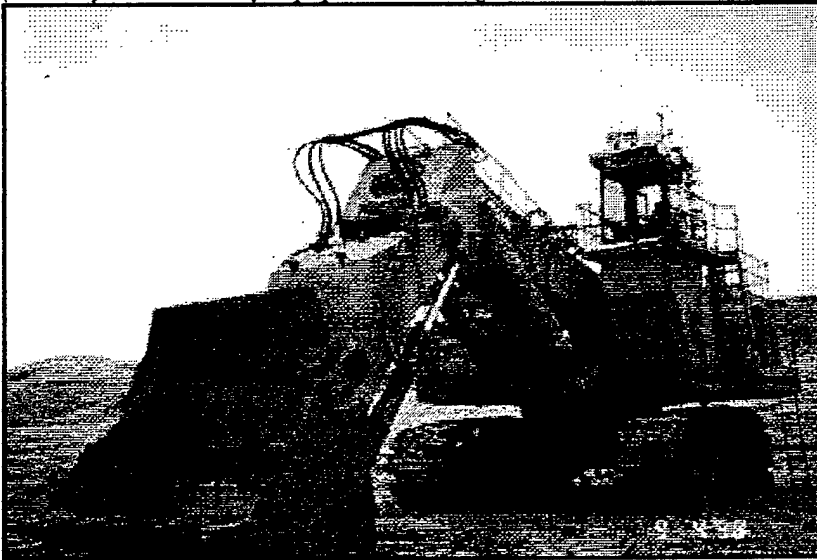

Figure 6-2

Front Shovel

(Courtesy Point 2 Heavy Equipment Exchange)



Production for shovels is based on the shovel's ideal productivity. Ideal productivity would be obtained if the shovel was operated at 100% efficiency under perfect conditions. This, however, is nearly impossible to obtain. Therefore, the actual production will be the ideal productivity adjusted by various factors.

There are two methods for obtaining ideal productivity. The first method is to obtain the ideal productivity from tables similar to Table 6-2. The second method is a mathematical solution based on the following formula:

$$\text{Ideal Productivity} = [(\text{Bucket Capacity}) \times (\text{Fill Factor})] \div \text{Ideal Cycle Time}$$

Shovel buckets are rated for heaped capacity, and this rating must be adjusted by a fill factor to account for different soil properties. Table 6-1 lists fill factors for different soil types. Analysis from manufacturers data indicates that shovel ideal cycle times fall into the range of 20 to 28 seconds for bottom dump buckets and 22 to 32 seconds for front dump buckets.⁽⁶⁻¹⁴⁰⁾

As mentioned previously, the ideal production must be adjusted by factors to account for actual conditions. These factors include:

- Swing/depth Factor (Table 6-3)
- Efficiency Factor (Table 5-1)

and the actual productivity is given by:

$$\text{Actual Productivity} = \text{Ideal Productivity} \times \text{Efficiency Factor} \times \text{Swing/depth Factor}$$

Table 6-1
Bucket Fill Factors For Shovels

Material	Bucket Fill Factor
Bank Clay; earth	1.00-1.10
Rock/Earth Mixtures	1.05-1.15
Poorly Blasted Rock	0.85-1.00
Well Blasted Rock	1.00-1.10
Shale; sandstone	0.85-1.10

Data for this table was extracted from *Reference 6, p. 140*

Table 6-2
Ideal Shovel Productivity in Bank Cubic Yards per Hour (BCY/hr)

Bucket Capacity	½ cy	¾ cy	1 cy	1 ¼ cy	1 ½ cy	1 ¾ cy	2 cy	2 ½ cy
<i>Material</i>								
Moist Loam	115	165	205	250	285	320	355	405
Sand and Gravel	110	155	200	230	270	300	330	390
Common Earth	95	135	175	210	240	270	300	350
Tough Clay	75	110	145	180	210	235	265	310
Well blasted rock	60	95	125	155	180	205	230	275
Earth/rock mixture	50	80	105	130	155	180	200	245
Wet Clay	40	70	95	120	145	165	185	230
Poorly blasted rock	25	50	75	95	115	140	160	195

Data for this table was extracted from *Reference 6, p. 140*

Table 6-3
Shovel Productivity Correction Factors for Depth of Cut and Angle of Swing

% of Optimum Depth	Angle of Swing						
	45°	60°	75°	90°	120°	150°	180°
40%	0.93	0.89	0.85	0.80	0.72	0.65	0.59
60%	1.10	1.03	0.96	0.91	0.81	0.73	0.66
80%	1.22	1.12	1.04	0.98	0.86	0.77	0.69
100%	1.26	1.16	1.07	1.00	0.88	0.79	0.71
120%	1.20	1.11	1.03	0.97	0.86	0.77	0.70
140%	1.12	1.04	0.97	0.91	0.81	0.73	0.66
160%	1.03	0.96	0.90	0.85	0.75	0.67	0.62

Data for this table was extracted from *Reference 6, p. 141*

Example 6-1

A contractor elects to use a bottom dump front excavator with a 1 cubic yard bucket and a 10 feet ideal depth of cut to perform the excavation for a new motel. The average depth of cut for this excavation will be 6 feet. The excavated material is common earth. The job conditions are excellent, while management conditions are fair. The job site provides for a 90° angle of swing. (a) Calculate the actual production of this shovel in BCY's based on an ideal productivity from table 6-2. (b) Calculate the actual production of this shovel in BCY's based on the ideal productivity formula.

Solution

(a)

Step 1 - Obtain Ideal Productivity (Table 6-2)

With 1 cy bucket and material common earth

Ideal Productivity = 175 BCY/hr

Step 2 - Determine Efficiency Factor (Table 5-1)

With Fair Management and Excellent Job Conditions

Efficiency Factor = 0.76

Step 3 - Determine Swing/Depth Factor (Table 6-3)

With 90° Angle of Swing and 60% depth of cut (6'/10')

Swing/Depth Factor = 0.91

Step 4 - Calculate Actual Production

Actual Production = Ideal Production x Efficiency Factor x Swing/Depth Factor

*Actual Production = 175 BCY/hr x 0.76 x 0.91 = **121.03 BCY/hr***

(b)

Step 1 - Obtain Ideal Productivity by Formula

With: Bucket Fill Factor = 1.10 (Table 6-1)

Swell = 25% (Table 4-1)

Ideal Cycle Time = 20 sec (estimated)

Ideal Productivity = [(Bucket Capacity) x (Fill Factor)] ÷ Ideal Cycle Time

Ideal Productivity = [1 LCY x 1.10 x 3600 sec/hr] ÷ [20 sec x 1.25 BCY/LCY]

Ideal Productivity = 158.4 BCY/hr

Step 2 - Calculate Actual Production

*Actual Production = 158.4 BCY/hr x 0.76 x 0.91 = **109.5 BCY/hr***

Example 6-1 illustrates that different methods may produce slightly different answers. It should also be noted that most manufactures have there own tables of adjustment factors, and the factors will generally differ slightly between manufactures.

6.2. Backhoes

Another popular piece of equipment for excavating is the hydraulic backhoe, Figure 6-3. Backhoes can be either wheel mounted or track mounted. Often small wheeled tractors will have a small backhoe attachment, Figure 6-4. For larger excavations

the backhoe will generally be track mounted. Backhoe components are illustrated on Figure 6-5.

The hydraulic backhoe's production is based on an ideal cycle time adjusted by an efficiency factor (Table 5-1) and a swing/depth factor (Table 6-6). Table 6-5 provides ideal cycle times for backhoes and can be used in developing the actual productivity. The following illustrates the formula for obtaining actual production in BCY/hr:

$$\text{Actual Production (BCY/hr)} = (C \times S \times V \times B \times E) \div (1 + \text{swell})$$

Where C = Cycles per hour
S = Swing/depth factor
V = Bucket volume
B = Bucket fill factor
E = Job efficiency

Figure 6-3

Hydraulic Backhoe

(Courtesy M. Adams Equipment Co.)



Figure 6-4

Tractor Backhoe

(Courtesy M. Adams Equipment Co.)

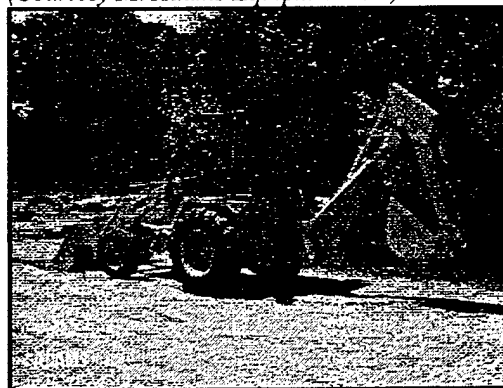

Figure 6-5
Backhoe Components
 (Extracted from *Reference 3, p. 58*)

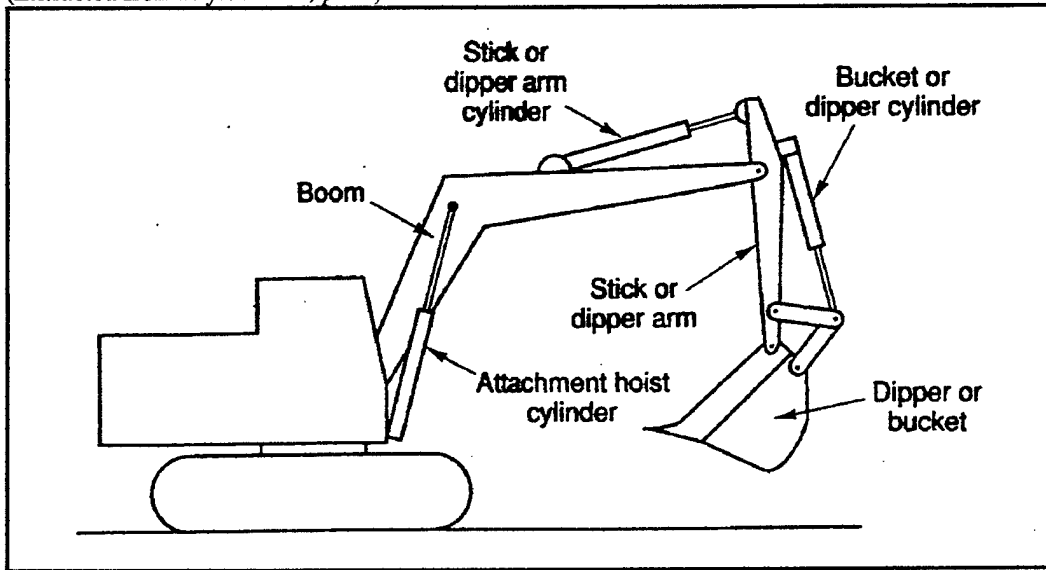

Table 6-4
Bucket Fill Factors For Backhoes

Material	Bucket Fill Factor
Moist Loam or Sandy Clay	1.00-1.10
Sand and Gravel	0.95-1.10
Hard Tough Clay	0.80-0.90
Well Blasted Rock	0.60-0.75
Poorly Blasted Rock	0.40-0.50

Data for this table was extracted from *Reference 6, p. 146*

Table 6-5
Standard Cycle Time for Hydraulic Backhoes (Cycles per Hour)

<i>Type of Material</i>	<i>Machine Size</i>			
	Wheeled Tractor	Small Excavator 1 cy or less	Medium Excavator 1 ¼ - 2 ¼ cy	Large Excavator 2 ½ cy and up
Sand, Gravel, Loam	170	250	200	150
Common Earth, Sandy Clays	135	200	160	120
Hard Clays & Rock	110	160	130	100

Data for this table was extracted from *Reference 3, p. 59*

Table 6-6
Swing Depth Factors for Backhoes

Depth of Cut (% of Max)	Angle of Swing (deg)					
	45	60	75	90	120	180
30	1.33	1.26	1.21	1.15	1.08	0.95
50	1.28	1.21	1.16	1.10	1.03	0.91
70	1.16	1.10	1.05	1.00	0.94	0.83
90	1.04	1.00	0.95	0.90	0.85	0.75

Data for this table was extracted from *Reference 3, p. 60*

Example 6-1

A contractor is excavating for a residential foundation & slab with a small wheeled tractor backhoe with a 1/4 cy bucket. The backhoe has a maximum depth of cut of 8'. The Material being excavated is sand, and the average depth of the excavation is 3'. The backhoe will be required to swing 75° to dump. What is the actual productivity of this backhoe in BCY/hr if it works 50 minutes/hr?

Solution

Step 1 - Calculate Actual Productivity

With: Bucket Fill Factor (B) = 1.10 (Table 6-4)
 Swell = 12% (Table 4-1)
 Standard Cycles (C) = 170 cycles/hr (Table 6-5)
 Bucket (V) = 1/4 cy
 Swing/Depth Factor (S) = 1.19 (Interpolate from Table 6-6)
 Efficiency Factor (E) = .83 (50/60)*
 Actual Production (BCY/hr) = (C x S x V x B x E) ÷ (1 + swell)
 Actual Production (BCY/hr) = (170 x 1.19 x .25 x 1.1 x .83) ÷ 1.12
 Actual Production = **41.2 BCY/hr**

**Remember, you use either a given number of minutes worked per hour as the efficiency factor or you obtain an efficiency factor from table 5-1, but you don't use both on the same problem!*

Hydraulic backhoes are often used to excavate trenches. Because trenches tend to cave in, some of the excavation time is wasted removing this cave in material. Therefore, Table 6-7 provides trench adjustment factors that should be used when calculating trenching production.

Table 6-7
Adjustment Factor for Trench Production

Type of Material	Adjustment Factor
Sand, Gravel, Loam	0.60-0.70
Common Earth	0.90-0.95
Firm Plastic Soils	0.95-1.00

Data for this table was extracted from *Reference 3, p. 60*

6.3. Draglines

Draglines have the advantage of superior reach and depth capabilities over their counterparts, the shovel and backhoe. Draglines perform their excavation cycle by simply dragging a bucket across the surface of the area to be excavated. The dragline relies on the weight of the bucket to provide its digging action. They do not have the same lateral support of a shovel or backhoe, and this will sometimes result in the dragline's bucket twisting or skipping. Because of their superior reach and depth, draglines are well suited for dredging and stockpiling operations. An illustration of the dragline's components is shown in Figure 6-6. An example of a dragline is shown in Figure 6-7.

Figure 6-6
Dragline Components
(Extracted from *Reference 3, p. 53*)

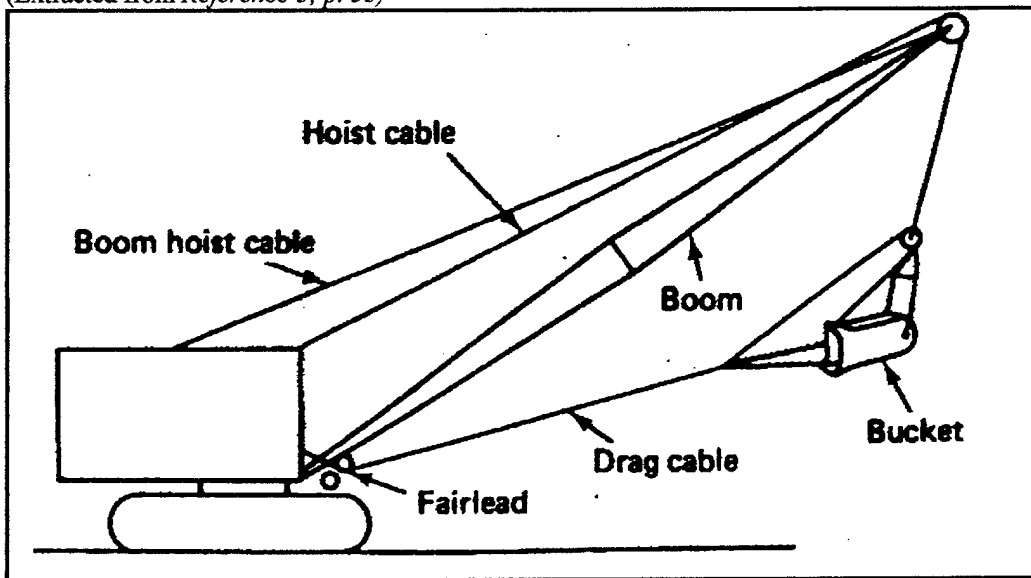
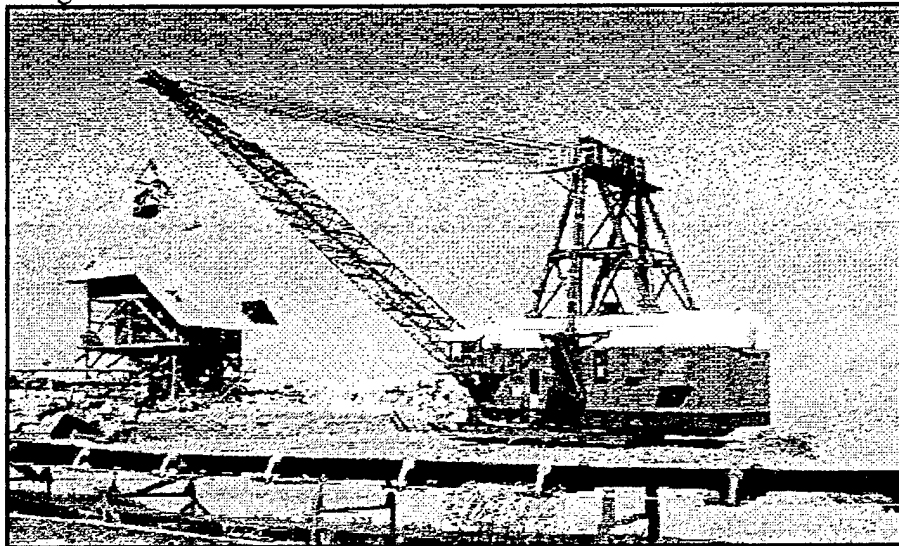

Figure 6-7
Dragline



Production for draglines is based on the dragline's ideal productivity. The dragline's ideal productivity will be adjusted by efficiency factors (Table 5-1) and swing depth factors (Table 6-10) to obtain the actual productivity.

$$\text{Actual Productivity} = \text{Ideal Productivity} \times \text{Efficiency Factor} \times \text{Swing/depth Factor}$$

Table 6-8

Ideal Dragline Production in Bank Cubic Yards per Hour (BCY/hr)

Bucket Capacity	¾ cy	1 cy	1 ¼ cy	1 ½ cy	1 ¾ cy	2 cy	2 ½ cy	3 cy
<i>Material Type</i>								
Moist Loam;								
Light Sandy Clay	130	160	195	220	245	265	305	350
Sand and Gravel	125	155	185	210	235	255	295	340
Common Earth	105	135	165	190	210	230	265	305
Hard, tough clay	90	110	135	160	180	195	230	270
Wet, sticky clay	55	75	95	110	130	145	175	210

Data for this table was extracted from *Reference 6, p. 152***Table 6-9**

Optimum Depth of Cut for Various Dragline Bucket Sizes (in feet)

Bucket Capacity	½ cy	¾ cy	1 cy	1 ¼ cy	1 ½ cy	1 ¾ cy	2 cy	2 ½ cy
<i>Material Type</i>								
Moist Loam;								
Light Sandy Clay	5.5	6.0	6.6	7.0	7.4	7.7	8.0	8.5
Sand and Gravel	5.5	6.0	6.6	7.0	7.4	7.7	8.0	8.5
Common Earth	6.7	7.4	8.0	8.5	9.0	9.5	9.9	10.5
Hard, tough clay	8.0	8.7	9.3	10.0	10.7	11.3	11.8	12.3
Wet, sticky clay	8.0	8.7	9.3	10.0	10.7	11.3	11.8	12.3

Data for this table was extracted from *Reference 6, p. 153***Table 6-10**

Dragline Productivity Correction Factors for Depth of Cut & Angle of Swing

% of Optimum Depth	Angle of Swing							
	30°	45°	60°	75°	90°	120°	150°	180°
20%	1.06	0.99	0.94	0.09	0.87	0.81	0.75	0.70
40%	1.17	1.08	1.02	0.97	0.93	0.85	0.78	0.72
60%	1.25	1.13	1.06	1.01	0.97	0.88	0.80	0.74
80%	1.29	1.17	1.09	1.04	0.99	0.90	0.82	0.76
100%	1.32	1.19	1.11	1.05	1.00	0.91	0.83	0.77
120%	1.29	1.17	1.09	1.03	0.98	0.90	0.82	0.76
140%	1.25	1.14	1.06	1.00	0.96	0.88	0.81	0.75
160%	1.20	1.10	1.02	0.97	0.93	0.85	0.79	0.73
180%	1.15	1.05	0.98	0.94	0.90	0.82	0.76	0.71
200%	1.10	1.00	0.94	0.90	0.87	0.79	0.73	0.69

Data for this table was extracted from *Reference 6, p. 153***Example 6-2**

A dragline with a 2 cubic yard bucket will be used to excavate for a landfill. The contractor estimates the total volume of the excavation to be 1,500,000 cubic yards of sandy clay. The average depth of excavation will be 15'. The dragline will be operating through a swing of 120°. Job management is good and job conditions are fair. Based on

this information what will the actual production be in bank cubic yards per hour (BCY/hr)? Additionally, what will the expected duration be for this excavation?

Solution

Step 1 - Calculate Ideal Production

$$\text{Ideal Production} = 265 \text{ BCY/hr (Table 6-8)}$$

Step 2 - Calculate Swing/depth Factor

$$\text{Optimum depth of cut} = 8.0' \text{ (Table 6-9)}$$

$$\% \text{ of Optimum} = 15'8' \times 100 = 187.5\%$$

$$\text{Swing} = 120^\circ$$

$$\text{Swing/depth Factor} = 0.81 \text{ (Table 6-10)}$$

Step 3 - Calculate Efficiency Factor

$$\text{Efficiency Factor} = 0.69 \text{ (Table 5-1)}$$

Step 4 - Calculate Actual Production

$$\text{Actual Productivity} = \text{Ideal Productivity} \times \text{Efficiency Factor} \times \text{Swing/depth Factor}$$

$$\text{Actual Productivity} = 265 \text{ BCY/hr} \times 0.69 \times 0.81$$

$$\text{Actual Productivity} = \underline{148.1 \text{ BCY/hr}}$$

Step 5 - Calculate Duration

$$\text{Duration} = \text{Quantity of Excavation} \div \text{Actual Production}$$

$$\text{Duration} = 1,500,000 \div 148.1 \text{ BCY/hr}$$

$$\text{Duration} = \underline{10,128.3 \text{ hrs, or 422 days}}$$

7. Tractors/Dozers

Tractors/dozers are a common sight on most construction sites. They are of two variants, either wheel type (Figure 7-1) or track type (Figure 7-2). Some common uses of tractors/dozers include:

- Backfilling
- Clearing & grubbing
- Creating stockpiles
- Excavating
- Slope shaping
- Spreading materials
- Towing
- Rough grading

There are many ways to calculate tractor/dozer production. Some methods include calculating theoretical blade capacity coupled with equipment cycle time and other factors. However, equipment manufactures generally have production charts, similar to Figure 7-3, for aiding the equipment manager in estimating production. These production estimating charts combined with the correction factors provided in Table 7-1 will provide the basis for evaluating tractor/dozer production here.

Figure 7-1
Wheel Type Dozer
(Courtesy Caterpillar)

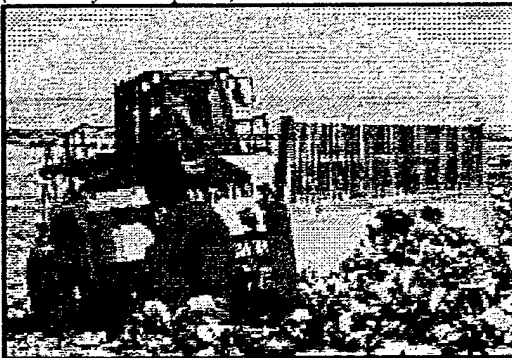

Figure 7-2
Track Type Dozer
(Courtesy M. Adams Equipment Co.)

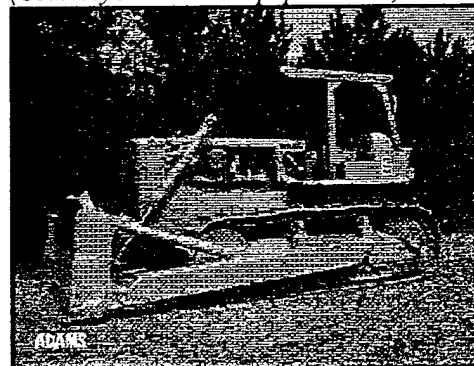

Figure 7-3
Estimated Dozing Production
 (Extracted from *Reference 1, p.113*)

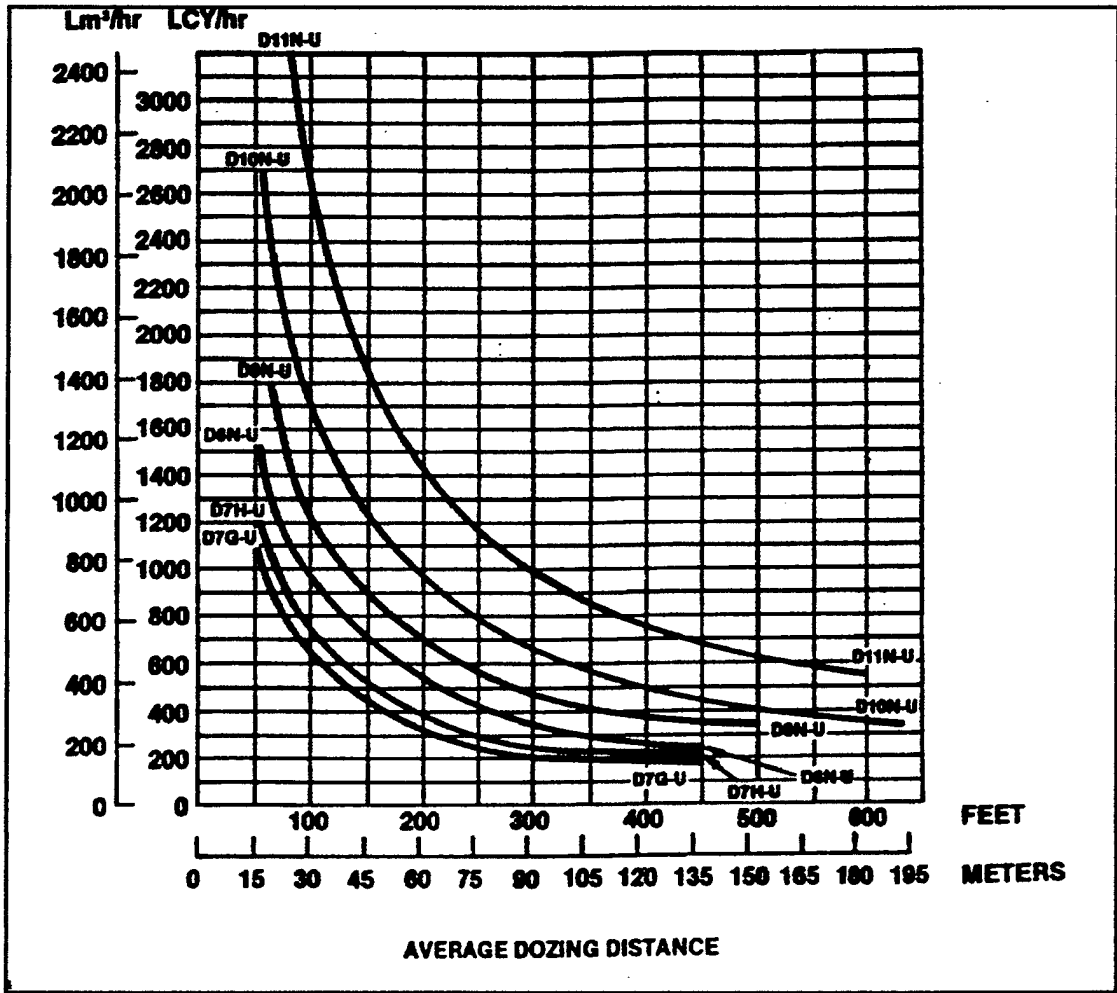

Table 7-1
Dozing Correction Factors

Job Condition Corrections	Track Type Tractor/Dozer	Wheel Type Tractor/Dozer
Operator		
Excellent	1.00	1.00
Average	0.75	0.60
Poor	0.60	0.50
Material		
<i>Loose stockpile</i>	1.20	1.20
<i>Hard to cut; frozen</i>		
with tilt cylinder	0.80	0.75
without tilt cylinder	0.70	n/a
cable-controlled blade	0.60	n/a
<i>Hard to drift material</i> (dry, non-cohesive or very sticky)	0.80	0.80
<i>Rock, ripped or blasted</i>	0.60 - 0.80	n/a
Slot Dozing	1.20	1.20
Side by side dozing	1.15 - 1.25	1.15 - 1.25
Visibility (dust, snow, and so on)	0.80	0.70
Direct Drive Transmission	0.80	n/a
Grades		
<i>favorable</i>		
-30%	1.6	1.6
-20%	1.4	1.4
-10%	1.2	1.2
<i>unfavorable</i>		
+10%	0.73	0.73
+20%	0.50	0.50
+30%	0.27	0.27

Data for this table was extracted from *Reference 1, p. 114*

Assumptions made in the above table include:

- 60 min/hr efficiency
- Fixed cycle time = 0.05 min
- Material dumped over a wall
- Load factor = 0.76
- Hydraulically controlled blade
- First gear forward for digging
- Second gear reverse for return
- Power shift transmission
- Dozer cuts 50' & drift remaining distance
- Soil unit weight is 2300 lb per LCY
- Coefficients of traction tracked 0.5 or better
- Coefficients of traction wheeled 0.45 or better
- Second gear forward for carrying

Example 7-1

A D11N-U Dozer with a universal blade is used to move dry non-cohesive sand with a unit weight of 2800 lb/LCY down a 20% average grade for 100 feet. The owner considers his operator to be excellent, and expects an efficiency of 50 minutes per hour. What is the expected production of this dozer in LCY/hr?

Solution

Step 1 - Calculate maximum dozer production

$$\text{Maximum Production} = \underline{2700 \text{ LCY/hr}} \text{ (Fig 7-3)}$$

Step 2 - Determine applicable correction factors (Table 7-1)

Excellent operator = 1.00

Non-cohesive sand = 0.80

Grade of -20% = 1.40

Weight correction = 0.82 (2300/2800, see assumptions for Table 7-1)

Efficiency = 0.83

Step 3 - Calculate expected production

Expected Production = Maximum Production x Correction Factors

Expected Production = 2700 x 1.00 x 0.80 x 1.40 x 0.82 x 0.83

Expected Production = 2058.1 LCY/hr

8. Loaders

There are two basic types of loaders; wheel type (Figure 8-1) and track type (Figure 8-2). Both are generally equipped with a bucket ranging in size from one cubic yard to four cubic yards. The maneuverability of loaders makes them extremely useful on a job site. Loaders can be employed in the following tasks:

- Excavation (soft to medium hard material)
- Loading hoppers
- Loading haul units
- Stockpiling material
- Backfilling
- Moving construction materials & concrete

Loader cycle time is based on basic cycle time, travel time, and correction factors. Table 8-1 list basic cycle times for various loaders, while Figures 8-3 and 8-4 provide graphs of travel time for wheel type and track type loaders respectively. Table 8-2 provides correction factors for various conditions. The equation for calculating cycle time is:

$$\text{Loader Cycle Time} = \text{BC} + \text{TT} + \text{CF}$$

Where BC = Basic Cycle Time (min)
TT = Travel Time (min)
CF = Correction Factors (min)

Figure 8-1
Wheel type loader
(Courtesy M. Adams Equipment Co.)



Figure 8-2
Track type loader
(Courtesy M. Adams Equipment Co.)



Figure 8-3
 Wheel loader travel time
 (Extracted from *Reference 4, p. 52*)

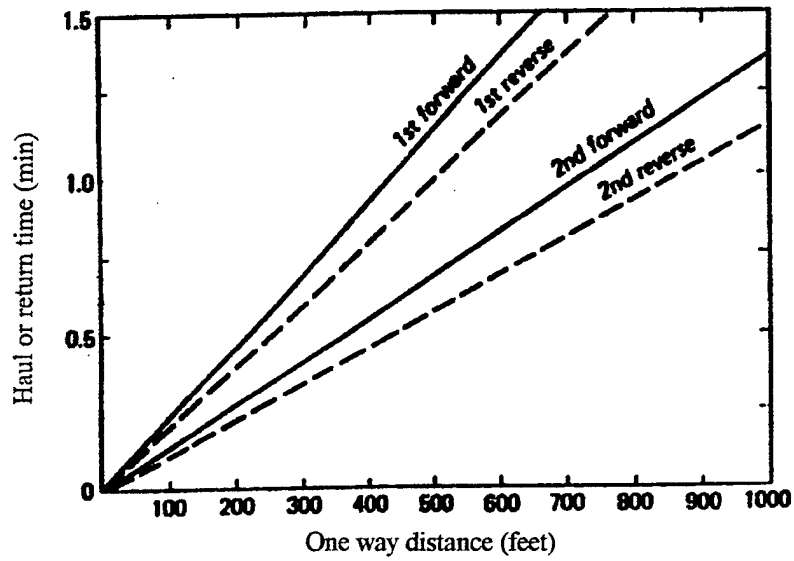

Figure 8-4
 Track loader travel time
 (Extracted from *Reference 4, p. 56*)

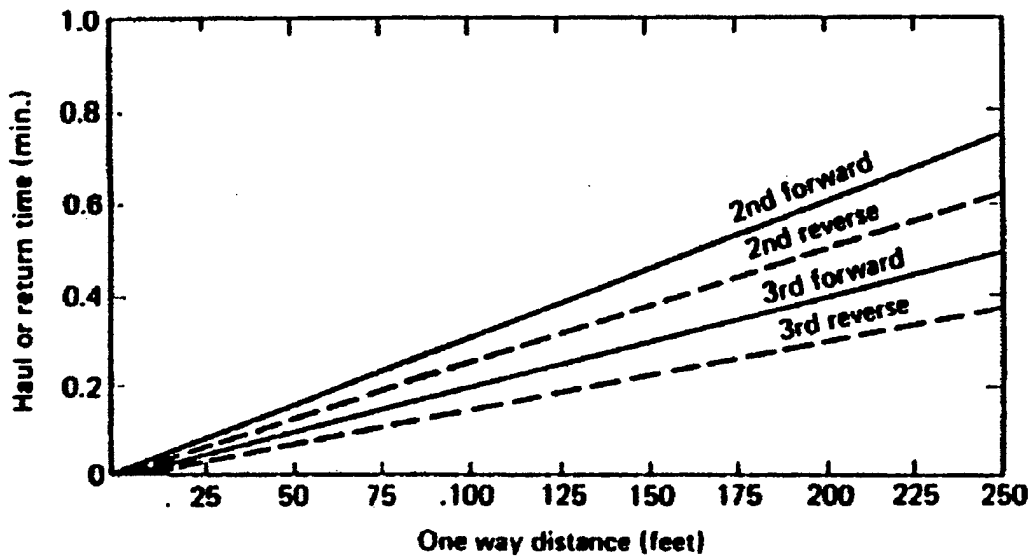

Table 8-1
Loader Basic Cycle Time

Loading Conditions	Basic Cycle Time (min)	
	Wheel Loader	Track Loader
Loose Materials	0.35	0.30
Average Material	0.50	0.35
Hard Material	0.65	0.45

Data for this table was extracted from *Reference 3, p. 104*

Table 8-2
Loader Correction Factors (minutes)

Element	Correction Factor (add to basic cycle time)
<i>Material</i>	
Common Earth (loam)	0.01 to 0.03
Mixed Aggregates	0.00 to 0.02
Uniform Aggregates:	
0 to ¾ in.	0.00 to -0.02
¾ to 6 in	0.00
Over 6 in	0.03 to 0.16
Soil with boulders and roots	0.01 to 0.16
Cemented materials	0.06 to 0.16
<i>Loading Conditions</i>	
Stockpile, under 10 ft high	0.01
Stockpile, over 10 ft	0.00
Dumped by truck	0.02
Bank	0.04
<i>Operating Conditions</i>	
Inconsistent operations	0.02 to 0.04
Small or fragile target	0.02 to 0.05
Independently owned trucks	0.02 to 0.04

Data for this table was extracted from *Reference 4, p. 53*

Loader production is calculated based on cycle time, and the loaders bucket capacity. Bucket capacity is adjusted by bucket fill factors shown in Table 8-3. The equation for calculating production is as follows:

$$\text{Loader Production} = (\text{Bucket Capacity} \times \text{FF} \times \text{EF}) \div \text{LC}$$

Where FF = Fill Factor
 EF = Efficiency Factor (min/hr)
 LC = Loader Cycle (min)

Table 8-3
Loader bucket fill factors

Material	Fill Factor
Mixed or uniform granular	0.95-1.00
Medium, coarse stone	0.85-0.90
Well blasted rock	0.80-0.95
Average blasted rock	0.75-0.90
Poorly blasted rock	0.60-0.75
Rock dirt mixtures	1.00-1.20
Moist loam	1.00-1.10
Cemented materials	0.85-0.95

Data for this table was extracted from *Reference 6, p. 108*

Example 8-1

A track loader with a 3 cubic yard bucket is used to move mixed aggregate from an 8' stockpile to a customer's truck. The distance from the stockpile to the truck is 75', and 2nd gear forward is used when traveling with a full bucket, and 3rd gear forward when returning. The loader works at an efficiency of 50min/hr. What is the estimated production of the loader?

Solution

Step 1 - Calculate Loader Cycle Time

$$\text{Loader Cycle Time} = BC + TT + CF$$

$$BC = \underline{0.30} \text{ (Table 8-1)}$$

$$TT = 0.23 \text{ for} + 0.13 \text{ rev} = \underline{0.36} \text{ min (Fig 8-4)}$$

$$CF = 0.02 + 0.01 + 0.03 = \underline{0.06} \text{ min (Table 8-2)}$$

$$\text{Loader Cycle Time} = 0.30 + 0.36 + 0.06 = \underline{0.72} \text{ min}$$

Step 2 - Calculate Loader Production

$$\text{Loader Production} = (\text{Bucket Capacity} \times FF \times EF) \div LC$$

$$\text{Loader Production} = (3\text{cy} \times 0.95 \times 50\text{min/hr}) \div 0.72\text{min}$$

$$\text{Loader Production} = \underline{197.9 \text{ LCY/hr}}$$

9. Hauling Equipment

In estimating hauling equipment cycle times and production it is important to consider some additional factors. These factors include the equipment's rolling resistance, grade resistance, and effective grade. The total resistance of a piece of equipment will be:

$$\text{Total Resistance} = \text{Rolling Resistance} + \text{Grade Resistance}$$

Resistance is typically expressed in pounds per ton of vehicle weight (lb/ton) or in pounds (lb's) only. For the purposes of this report, resistance factors will carry the unit of lb/ton and resistance will carry the unit of lb's.

9.1. Rolling Resistance

Rolling resistance is primarily a factor of the resistance incurred from tire flexing and penetration of tires into the surface being traversed. It has been shown that a vehicle traveling over a hard surface roadway will have a rolling resistance factor of about 40 lb/ton of vehicle weight, and this will increase by 30 lb/ton of vehicle weight for each inch of tire surface penetration. This leads to the following equation for rolling resistance factor:

$$\text{Rolling Resistance Factor (lb/ton)} = 40 + (30 \times \text{Inches of tire penetration})$$

Table 9-1 provides a list of some typical values of rolling resistance factors.

Table 9-1
Typical Values of Rolling Resistance Factors

Type of Surface	Rolling Resistance Factor (lb/ton)
Concrete or Asphalt	40 (30)*
Firm, smooth, flexing slightly under load	64 (52)*
Rutted dirt roadway, 1-2 inches penetration	100
Soft, rutted dirt, 3-4 inches penetration	150
Loose sand or gravel	200
Soft, muddy, deeply rutted	300-400

*Values in parenthesis are for radial tires

Data for this table was extracted from *Reference 3, p. 84*

9.2. Grade Resistance

Grade resistance results from resistance encountered as a result of positive or negative grades. Grade resistance is that component of resistance acting parallel to the grade. The actual grade resistance can be obtained by multiplying the sine of the angle of grade with respect to horizontal by the vehicles weight. However, because the grades in construction are typically small, it is generally accepted that 1% of grade will have a grade resistance of 1% of a vehicles weight. This corresponds to a grade resistance factor of 20lb/ton for each 1% of grade, or:

$$\text{Grade Resistance Factor (lb/ton)} = 20 \times \text{grade (\%)} \\ \text{Grade Resistance (lb)} = \text{Vehicle wight (tons)} \times \text{Grade Resistance Factor (lb/ton)}$$

9.3. Effective Grade

Effective grade is a simple method of representing the sum of rolling resistance and grade resistance. Effective grade is important because it is often used in equipment manufactures performance charts for estimating equipment performance parameters. Effective grade is the method that will be demonstrated in this paper. The equation for effective grade is given by:

$$\text{Effective Grade} = \text{Grade (\%)} + [\text{Rolling Resistance Factor (lb/ton)} \div 20]$$

9.4. Scrapers

A scraper is a single piece of equipment that has the ability to excavate, load, haul, and dump. There are a number of different scraper types including:

- Single Engine Overhung
- Three Axle
- Twin Engine, All Wheel Drive (Figure 9-1)
- Elevating (Figure 9-2)
- Push Pull

Figure 9-1
Twin Engine, All Wheel Drive Scraper
(Courtesy M. Adams Equipment Co.)

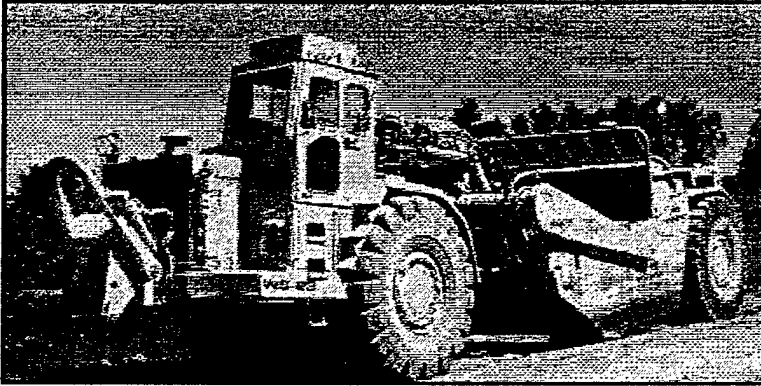

Figure 9-2
Elevating Scraper
(Courtesy M. Adams Equipment Co.)



Scraper production is estimated based on the scraper's cycle time and hauling capacity; much like other equipment.

A scraper's cycle time is based on fixed cycle time and variable cycle time. Fixed cycle time includes the time required to spot, load, and maneuver and dump. Table 9-2 provides typical values of scraper fixed cycle times.

Table 9-2
Scraper Fixed Cycle Time (min)

	Spot Time	
	Single Pusher	Tandem Pusher
Favorable	0.2	0.1
Average	0.3	0.2
Unfavorable	0.5	0.5

	Load Time				
	Single Pusher	Tandem Pusher	Elevating Scraper	Auger	Push-Pull*
Favorable	0.5	0.4	0.8	0.7	0.7
Average	0.6	0.5	1.0	0.9	1.0
Unfavorable	1.0	0.9	1.5	1.3	1.4

	Maneuver & Dump	
	Single Engine	Twin Engine
Favorable	0.3	0.3
Average	0.7	0.6
Unfavorable	1.0	0.9

*Per pair of scrapers

Data for this table was extracted from *Reference 3, p. 109*

The second element of a scraper's cycle time is the variable cycle time. Variable cycle time includes the sum of the time required to haul the material, dump the material, and return to the point of excavation. One method of estimating variable cycle for scrapers is to use travel time curves (Figures 9-3 & 9-4). The haul route will need to be broken into sections with similar characteristics of grade, load, etc..

Figure 9-3
 Scraper Distance versus Time (loaded)
 (Courtesy of Caterpillar, Inc.)

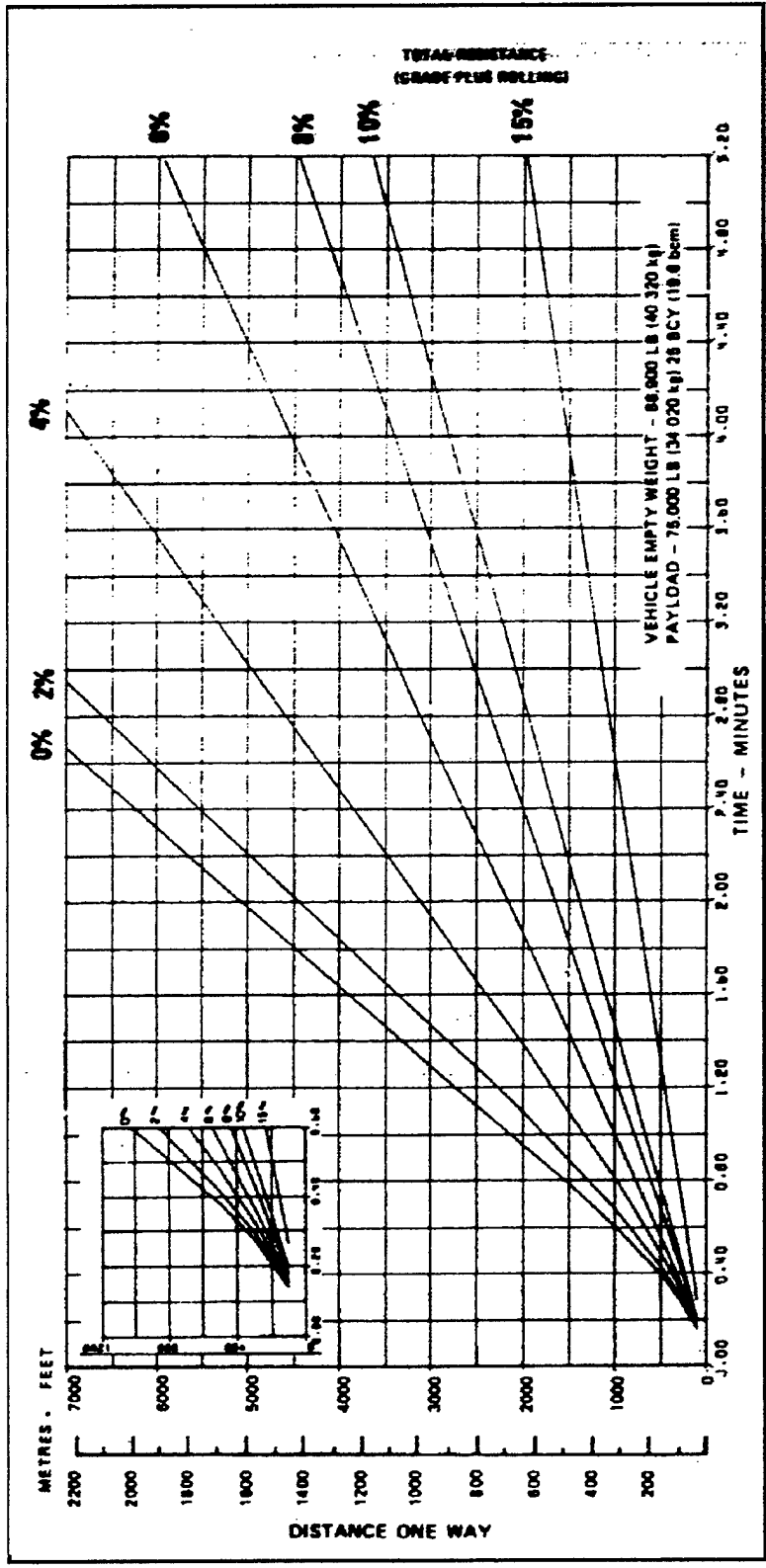
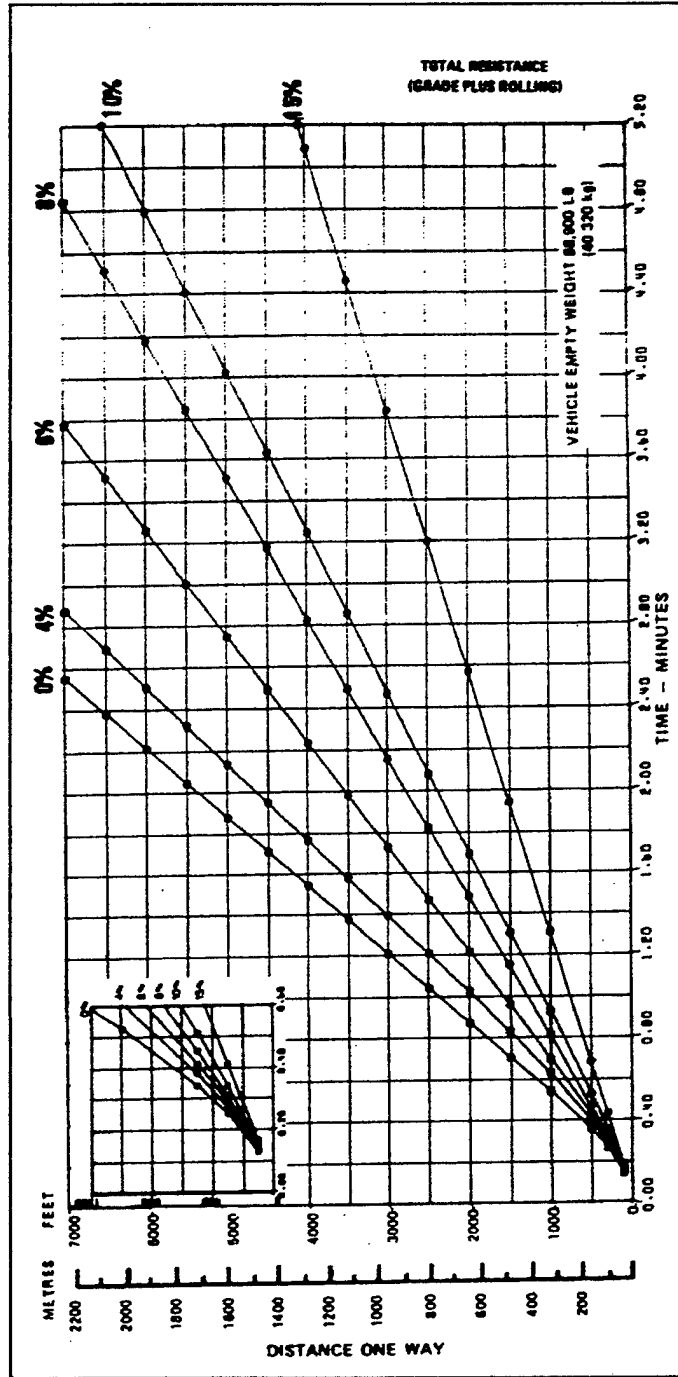

Figure 9-4
 Scraper Distance versus Time (empty)
 (Courtesy of Caterpillar, Inc.)



In determining a scrapers per cycle capacity, one must consider both the scrapers rated payload capacity and volumetric capacity. The governing value will be the lesser of the two capacities. For example, if a scraper is rated for a 50,000 lb payload and 30 LCY's volume, and the material being excavate has a unit weight of 2,000 lb/LCY, then payload would govern, because 30 LCY's of a 2,000 lb/LCY material would weigh 60,000 lb, which exceeds the rated payload capacity. Therefore, in this example the scraper could only handle a volume of 50,000 lb divided by 2,000 lb/LCY or 25 LCY of material not the rated 30 LCY.

Example 9-1

A single engine tandem pusher scraper, which has travel time/distance curves as shown in figures 9-3 & 9-4 is being used to excavate for a large parking lot. The scraper has a heaped volume capacity of 30 LCY, and a maximum payload capacity of 65,000 lb. The material being removed is sand with a unit weight of 2,800 lb/LCY and 3,200 lb/BCY. The job conditions are average and job efficiency is equivalent to 50 min/hr. The scraper is working in a dirt roadway environment with approximately 1.5 inch of tire penetration. The haul route can be broken up as follows:

1. Level loading area
2. Haul down a 4% grade for 1,500 feet
3. Level dump area
4. Return up a 4% grade for 1,500 feet
5. Level turnaround of 600 feet

Based on this information, what will is the estimated scraper production?

Solution

Step 1- Calculate weight of heaped capacity

$$\text{Weight of Heaped Capacity} = \text{Loose Unit Weight} \times \text{Capacity} = 2,800 \text{ lb/LCY} \times 30 \text{ LCY}$$

$$\text{Weight of Heaped Capacity} = 84,000 \text{ lb}$$

Note: Weight of heaped capacity (84,000 lb) exceeds rated payload capacity of 65,000 lb, therefore scraper will work at less than heaped capacity.

Step 2 - Calculate Maximum Capacity (BCY)

$$\text{Maximum Capacity (BCY)} = \text{Payload Capacity} \div \text{Bank Unit Weight}$$

$$\text{Maximum Capacity (BCY)} = 65,000 \text{ lb} \div 3,200 \text{ lb/BCY}$$

$$\text{Maximum Capacity} = 20.31 \text{ BCY}$$

Step 3 - Calculate Effective Grades (EG)

Where:

$$EG = \text{Grade (\%)} + [\text{Rolling Resistance Factor (lb/ton)} \div 20]$$

Haul:

$$EG = -4\% + [100 \div 20] = 1\%$$

Return:

$$EG = 4\% + [100 \div 20] = 9\%$$

Turnaround:

$$EG = 0\% + [100 \div 20] = 5\%$$

Step 4 - Calculate variable cycle time from Figures 9-3 & 9-4

Haul = 0.84 min

Return = 1.20 min

Turnaround = 0.41 min

Step 5 - Calculate fixed cycle time from Table 9-2

Spot = 0.2 min

Load = 0.5 min

Maneuver/Dump = 0.7 min

Step 6 - Calculate Total Cycle Time

$$\text{Total Cycle} = \text{fixed cycle} + \text{variable} = 0.84 + 1.20 + 0.41 + 0.2 + 0.5 + 0.7$$

$$\text{Total Cycle} = 3.85 \text{ min}$$

Step 7 - Calculate estimated production

$$\text{Estimated Production} = [\text{Maximum Capacity (BCY)} \times \text{Efficiency (min/hr)}] \div \text{Total Cycle}$$

$$\text{Estimated Production} = [20.31 \text{ BCY} \times 50 \text{ min/hr}] \div 3.85 \text{ min}$$

$$\text{Estimated Production} = \underline{263.8 \text{ BCY/hr}}$$

9.5. Push Loading

Sometimes the available power of scraper is not sufficient to allow the scraper to operate under its own power. In such a case the equipment manager will want to employ a method known as push loading. Push loading is when a tractor is used to push a scraper during the scraping operation. Figure 9-5 is an example of a scraper being push loaded.

Figure 9-5

Scraper Being Push Loaded

(Extracted from Reference 6, p. 117)

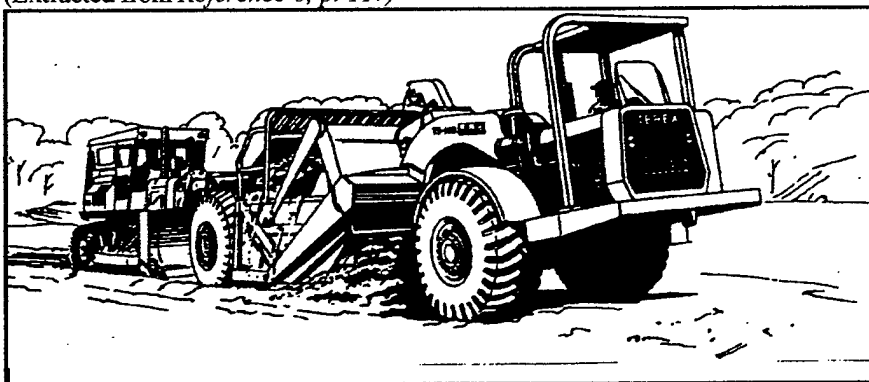

There are three basic methods of push loading. The three methods are Back Track Loading, Chain Loading, and Shuttle Loading. Figure 9-6 illustrates the three methods of push loading. Typically push loading will be accomplished by using either one pusher per scraper or two pushers per scraper.

Figure 9-6
Methods of Push Loading
(Extracted from *Reference 3, p. 113*)

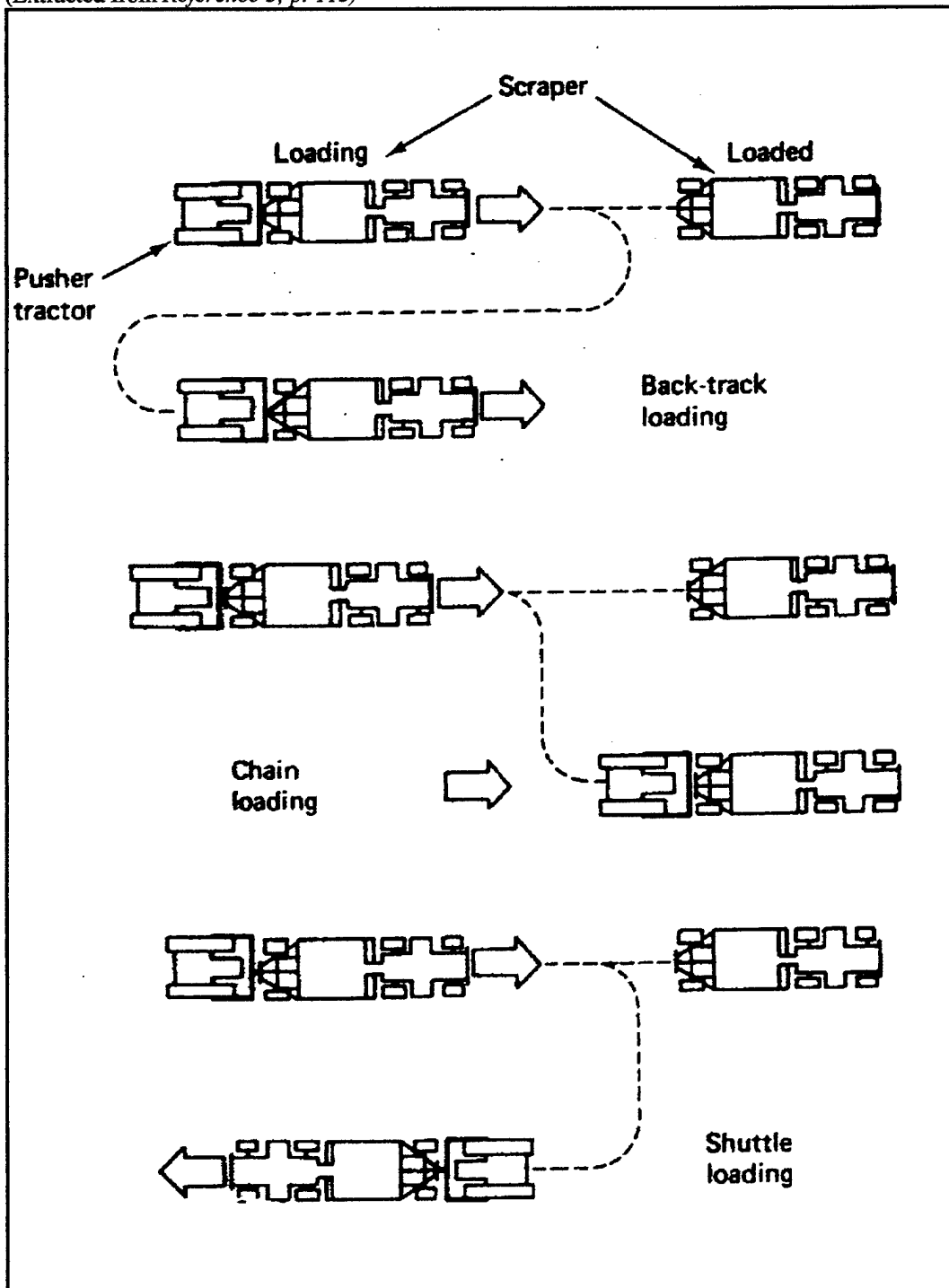

Because a tractor is involved in a push loading operation, it is important to be able to determine the number of scrapers that a pusher can support, and the number of pushers required to support a fleet of scrapers. These numbers can be obtained with the following equations:

$$\text{No. scrapers served by one pusher} = \text{Scraper Cycle Time} \div \text{Pusher Cycle Time}$$

$$\text{Number of Pushers Required} = \text{Number of Scrapers} \div \text{No. scrapers served by one pusher}$$

Table 9-3 provides a list of typical pusher cycle times.

Table 9-3

Typical Pusher Cycle Times (min)

Loading Method	Single Pusher	Tandem Pusher
Back Track	1.5	1.4
Chain or Shuttle	1.0	0.9

Data for this table was extracted from *Reference 3, p. 116*

To determine the expected production of a scraper fleet the following equation applies:

$$\text{Fleet Production} = [\text{No. of Pushers} \div \text{No. Pushers Required}] \times \text{No. Scrapers} \times \text{Single Scraper Production}$$

Example 9-2

A contractor is employing a fleet of 6 scrapers with single pushers for back track push loading. The estimated cycle time for each scraper is 5 minutes. The scrapers have a capacity of 200 BCY per hour, and the contractor has 3 dozers available for pushig.

(a) What is the number of pushers required to serve the fleet? (b) What is the estimated production of this fleet?

Solution

(a)

$$\text{No. scrapers served by one pusher} = 5 \text{ min} \div 1.5 = 3.33 \text{ scrapers/pusher}$$

$$\text{No. pushers required} = 6 \div 3.33 = \underline{1.8 \text{ use 2 pushers}}$$

(b)

$$\text{Fleet Production} = [3 \div 3.33] \times 6 \times 200 \text{ BCY/hr} = \underline{1081.1 \text{ BCY/hr}}$$

9.6. Trucks

It is obvious that hauling is a major part of any earthmoving process, and the most prevalent piece of equipment used for hauling materials in the construction industry is the truck. Many trucks are licensed for highway use, which is of particular usefulness when a borrow pit or dump site is located some distance from the construction site. Knowing that trucks are one of the most popular haulers, it is important to be familiar with estimating truck production.

Truck production is based on cycle time. A truck's cycle time has two components, fixed cycle time and variable cycle time. Fixed cycle time is the time required for spot, maneuver, and dump. Table 9-4 list typical fixed cycle times for trucks. The second component of truck cycle time is the variable component. Variable cycle time consists of the load time and haul time. Load time is given by the following equation:

$$\text{Load Time} = \text{Haul Unit Capacity} \div \text{Loader Production}$$

The haul time can simply be calculated by dividing the distance to the dump site by the average speed of the truck.

Table 9-4
Typical Truck Fixed Cycle Times (min)

	Bottom Dump	Rear Dump
Favorable	1.1	0.5
Average	1.6	1.1
Unfavorable	2.0	2.5

Data for this table was extracted from *Reference 3, p. 121*

Because it is inefficient to have either loaders or haulers sitting idle, it is important to accurately calculate the number of haul units required to support a loading operation. The number of haulers required to support a loading operation is given by:

$$\text{Number of haulers required} = \text{Haul Unit Cycle Time} \div \text{Load Time}$$

The aforementioned equation provides the theoretical number of haulers required for a loading operation, however, the actual number of haulers available may differ from

the theoretical number required. When the actual number of haulers differs from the theoretical number required, production can be estimated with the following equation:

$$\text{Expected Production} = (\text{Haul Units Available} \div \text{Number Haulers Required}) \times \text{loader production}$$

Example 9-3

Based on the following loader truck operation, (a) calculate the number of trucks required theoretically to support the operation; (b) calculate the expected production if 8 trucks are available.

Loader Production	= 350 BCY/hr
Job Efficiency	= 50 min/hr
Truck Capacity	= 20 BCY
Truck Cycle Time	= 0.5 hr (not including loading)

Solution

(a)

Step 1 - Calculate Load Time

$$\text{Load Time} = \text{Haul Unit Capacity} \div \text{Loader Production} = 20 \text{ BCY} \div 350 \text{ BCY/hr}$$
$$\text{Load Time} = \mathbf{0.057 \text{ hr}}$$

Step 2 - Calculate Truck Cycle Time

$$\text{Truck Cycle} = 0.5 \text{ hr} + 0.057 \text{ hr} = \mathbf{0.557 \text{ hr}}$$

Step 3 - Calculate Number Trucks Required

$$\text{Number Trucks Required} = \text{Haul Unit Cycle Time} \div \text{Load Time}$$

$$\text{Number Trucks Required} = 0.557 \text{ hr} \div 0.057$$

$$\text{Number Trucks Required} = \mathbf{9.8 \text{ (in theory)}}$$

(b)

Step 1 - Calculate Expected Production of 8 Trucks

$$\text{Expected Production} = (\text{Haul Units Available} \div \text{Number Haulers Required}) \times \text{loader production}$$

$$\text{Expected Production} = (8 \div 9.8) \times 50\text{min}/60\text{min} \times 350 \text{ BCY/hr}$$

$$\text{Expected Production} = \mathbf{238 \text{ BCY/hr}}$$

10. Equipment Selection

It is often necessary for an equipment manager to evaluate two equipment alternatives to determine which is the most advantageous. The alternatives being evaluated will likely have different costs per quantity, costs per time, and fixed costs. There are several methods for making this determination, but only one method will be presented here, and that method is the Line of Balance Method.

10.1. Line of Balance

The Line of Balance Method is a mathematical model for analyzing two equipment alternatives for the purpose of selecting the most advantageous.

To employ the Line of Balance Method a cost equation for each option must be developed. The equation will take into account fixed costs, time dependant costs, and quantity dependant costs.

Fixed Costs include, but are not limited to:

- Move In
- Move Out
- Mobilization
- Demobilization
- Purchase Price

Time dependant costs include, but are not limited to:

- Rental Costs
- Interest

Quantity dependant costs include, but are not limited to:

- Wages
- Operating Costs

The total costs of each option will include the sum of fixed costs, time dependant costs, and quantity dependant costs. The following equation represents the total costs of a given option:

$$C_t = C_f + C_{td} + C_{qty}$$

Where Ct = Total Cost
 Cf = Fixed Costs
 Ctd = Time Dependant Costs
 Cqty = Quantity Dependant Costs

Example 10-1

Find the cost equation for an equipment option with the following cost data:

Move in/Move out = \$2,000
 Monthly Rental = \$1,500/month
 Productivity = 6 CY/hr
 Labor Costs = \$25/hr
 Operating Costs = \$5/hr

Equation

$$Ct = 2,000 + 1,500T + [(\$25 + \$5) \div 6 \text{ CY/hr}]Q$$

$$Ct = 2,000 + 1,500T + 5Q$$

Where T = Time (months)
 Q = Quantity (cubic yards)

Once the equation for each option is obtained, the equations are set equal to one another, such that the resulting combined equation is that of a straight line. This equation is then plotted. From this plot a determination of which option is best for a given quantity and time can be made. The following example illustrates the entire Line of Balance Method.

Example 10-2

Data

	Small Mixer	Large Mixer
Mobilization/Demobilization	\$2,000	\$4,000
Monthly Rental Costs	\$1,500/month	\$2,500/month
Productivity	6 CY/hr	10 CY/hr
Number of Laborers	5	3
Wages	\$5/hr	\$6/hr
Operating Cost	\$5/hr	\$2/hr

This equipment will be used to place 1000 cubic yards of concrete, and it must be completed within 3 months. Which mixer is more advantageous?

Solution

Step 1 - Calculate the cost equation for the small mixer

$$C_{\text{small mixer}} = 2,000 + 1,500T + [(\$5 \times 5) + \$5] \div 6 \text{ CY/hr}]Q$$

$$C_{\text{small mixer}} = 2,000 + 1,500T + 5Q$$

Step 2 - Calculate the cost equation for the large mixer

$$\text{Clarge mixer} = 4,000 + 2,500T + [((\$6 \times 3) + \$2)] \div 10 \text{ CY/hr}]Q$$

$$\text{Clarge mixer} = 4,000 + 2,500T + 2Q$$

Step 3 - Combine Cost Equations

$$C_{\text{small mixer}} = C_{\text{large mixer}}$$

$$2000 + 1,500T + 5Q = 4,000 + 2,500T + 2Q$$

$$Q = (2,000 + 1000T) \div 3$$

Step 4 - Plot combined equation

Combined Equation Plot

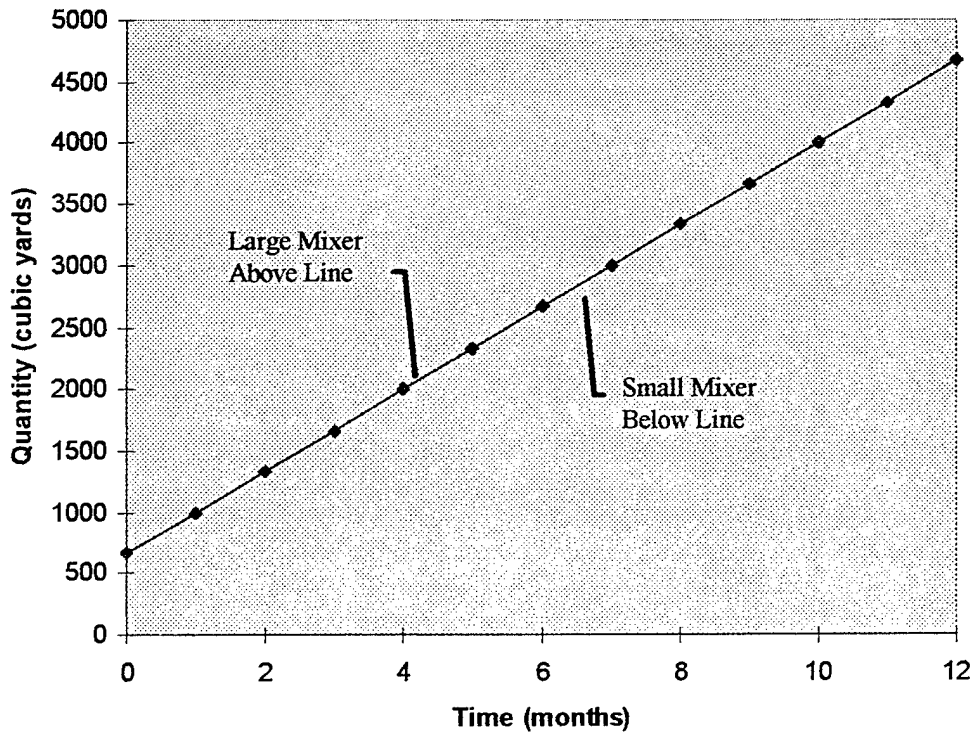

Step 5 - Use 3 months and 1,000 cubic yards and solve for each mixer equation.

Small Mixer

$$C_{\text{small mixer}} = 2,000 + 1,500(3) + 5(1000)$$

$$C_{\text{small mixer}} = \$11,500$$

Large Mixer

$$C_{\text{large mixer}} = 4,000 + 2,500(3) + 2(1000)$$

$$C_{\text{large mixer}} = \$13,500$$

From this it can be determined that at 3 months and 1000 cubic yards the small mixer is more advantageous, and the intersection of 3 months and 1000 cubic yards falls below the plotted line. Therefore, the area below the line represents the area more advantageous to the small mixer and visa versa.

What would happen if there was a mistake in estimating the quantity, and the job required 2,000 cubic yards instead of 1,000 cubic yards?

In this case the intersection of 3 months and 2,000 cubic yards falls above the plotted line. Therefore, the large mixer would be selected.

In the preceding example the Line of Balance Method was used to evaluate two pieces of equipment. It should be noted that this method is not limited to only two pieces of equipment. This method could be used to analyze multiple options.

References

1. Day, David A., Construction Equipment Guide, Second Edition, John Wiley & Sons, Inc., New York, 1991
2. Drevdahl, Elmer R., Fundamentals of Excavation Equipment, Roadrunner Technical Publications Desert Laboratories, Inc., Arizona, 1963
3. Nunnally, S. W., Construction Methods and Management, Prentice-Hall, Inc., New Jersey, 1998
4. Nunnally, S. W., Managing Construction Equipment, Prentice-Hall, Inc., New Jersey, 1977
5. Peurifoy, R. L. and W. B. Ledbetter, Construction Planning Equipment, and Methods, Fourth Edition, McGraw-Hill, Inc., 1985
6. Schaufelberger, John E., Construction Equipment Management, Prentice-Hall, Inc., New Jersey, 1999
7. White, John A., Marvin H. Agee, and Kenneth E. Case, Principles of Engineering Economic Analysis, Third Edition, John Wiley & Sons, Inc., New York, 1989
8. U. S. Army Corps of Engineers, Construction Equipment Ownership and Operating Expense Schedule, Volume II, August 1995
9. Rental Rate Blue Book, Volume 1, Dataquest Incorporated, 1992

Appendix A
Compound Interest Tables

Compound Interest Table for: $i = 1\%$

n	Single Payment		Uniform Series			
	Compound Amount Factor	Present Worth Factor	Compound Amount Factor	Sinking Fund Factor	Present Worth Factor	Capital Recovery Factor
	To find F when given a P (F/P, i, n)	To find P when given an F (P/F, i, n)	To find F when given an A (F/A, i, n)	To find A when given an F (A/F, i, n)	To find P when given an A (P/A, i, n)	To find A when given a P (A/P, i, n)
1	1.0100	0.9901	1.0000	1.0000	0.9901	1.0100
2	1.0201	0.9803	2.0100	0.4975	1.9704	0.5075
3	1.0303	0.9706	3.0301	0.3300	2.9410	0.3400
4	1.0406	0.9610	4.0604	0.2463	3.9020	0.2563
5	1.0510	0.9515	5.1010	0.1960	4.8534	0.2060
6	1.0615	0.9420	6.1520	0.1625	5.7955	0.1725
7	1.0721	0.9327	7.2135	0.1386	6.7282	0.1486
8	1.0829	0.9235	8.2857	0.1207	7.6517	0.1307
9	1.0937	0.9143	9.3685	0.1067	8.5660	0.1167
10	1.1046	0.9053	10.4622	0.0956	9.4713	0.1056
11	1.1157	0.8963	11.5668	0.0865	10.3676	0.0965
12	1.1268	0.8874	12.6825	0.0788	11.2551	0.0888
13	1.1381	0.8787	13.8093	0.0724	12.1337	0.0824
14	1.1495	0.8700	14.9474	0.0669	13.0037	0.0769
15	1.1610	0.8613	16.0969	0.0621	13.8651	0.0721
16	1.1726	0.8528	17.2579	0.0579	14.7179	0.0679
17	1.1843	0.8444	18.4304	0.0543	15.5623	0.0643
18	1.1961	0.8360	19.6147	0.0510	16.3983	0.0610
19	1.2081	0.8277	20.8109	0.0481	17.2260	0.0581
20	1.2202	0.8195	22.0190	0.0454	18.0456	0.0554
21	1.2324	0.8114	23.2392	0.0430	18.8570	0.0530
22	1.2447	0.8034	24.4716	0.0409	19.6604	0.0509
23	1.2572	0.7954	25.7163	0.0389	20.4558	0.0489
24	1.2697	0.7876	26.9735	0.0371	21.2434	0.0471
25	1.2824	0.7798	28.2432	0.0354	22.0232	0.0454
26	1.2953	0.7720	29.5256	0.0339	22.7952	0.0439
27	1.3082	0.7644	30.8209	0.0324	23.5596	0.0424
28	1.3213	0.7568	32.1291	0.0311	24.3164	0.0411
29	1.3345	0.7493	33.4504	0.0299	25.0658	0.0399
30	1.3478	0.7419	34.7849	0.0287	25.8077	0.0387
31	1.3613	0.7346	36.1327	0.0277	26.5423	0.0377
32	1.3749	0.7273	37.4941	0.0267	27.2696	0.0367
33	1.3887	0.7201	38.8690	0.0257	27.9897	0.0357
34	1.4026	0.7130	40.2577	0.0248	28.7027	0.0348
35	1.4166	0.7059	41.6603	0.0240	29.4086	0.0340
36	1.4308	0.6989	43.0769	0.0232	30.1075	0.0332
37	1.4451	0.6920	44.5076	0.0225	30.7995	0.0325
38	1.4595	0.6852	45.9527	0.0218	31.4847	0.0318
39	1.4741	0.6784	47.4123	0.0211	32.1630	0.0311
40	1.4889	0.6717	48.8864	0.0205	32.8347	0.0305
45	1.5648	0.6391	56.4811	0.0177	36.0945	0.0277
48	1.6122	0.6203	61.2226	0.0163	37.9740	0.0263
50	1.6446	0.6080	64.4632	0.0155	39.1961	0.0255
54	1.7114	0.5843	71.1410	0.0141	41.5687	0.0241
60	1.8167	0.5504	81.6697	0.0122	44.9550	0.0222

Compound Interest Table for: $i = 2\%$

n	Single Payment		Uniform Series			
	Compound Amount Factor	Present Worth Factor	Compound Amount Factor	Sinking Fund Factor	Present Worth Factor	Capital Recovery Factor
	To find F when given a P (F/P, i, n)	To find P when given an F (P/F, i, n)	To find F when given an A (F/A, i, n)	To find A when given an F (A/F, i, n)	To find P when given an A (P/A, i, n)	To find A when given a P (A/P, i, n)
1	1.0200	0.9804	1.0000	1.0000	0.9804	1.0200
2	1.0404	0.9612	2.0200	0.4950	1.9416	0.5150
3	1.0612	0.9423	3.0604	0.3268	2.8839	0.3468
4	1.0824	0.9238	4.1216	0.2426	3.8077	0.2626
5	1.1041	0.9057	5.2040	0.1922	4.7135	0.2122
6	1.1262	0.8880	6.3081	0.1585	5.6014	0.1785
7	1.1487	0.8706	7.4343	0.1345	6.4720	0.1545
8	1.1717	0.8535	8.5830	0.1165	7.3255	0.1365
9	1.1951	0.8368	9.7546	0.1025	8.1622	0.1225
10	1.2190	0.8203	10.9497	0.0913	8.9826	0.1113
11	1.2434	0.8043	12.1687	0.0822	9.7868	0.1022
12	1.2682	0.7885	13.4121	0.0746	10.5753	0.0946
13	1.2936	0.7730	14.6803	0.0681	11.3484	0.0881
14	1.3195	0.7579	15.9739	0.0626	12.1062	0.0826
15	1.3459	0.7430	17.2934	0.0578	12.8493	0.0778
16	1.3728	0.7284	18.6393	0.0537	13.5777	0.0737
17	1.4002	0.7142	20.0121	0.0500	14.2919	0.0700
18	1.4282	0.7002	21.4123	0.0467	14.9920	0.0667
19	1.4568	0.6864	22.8406	0.0438	15.6785	0.0638
20	1.4859	0.6730	24.2974	0.0412	16.3514	0.0612
21	1.5157	0.6598	25.7833	0.0388	17.0112	0.0588
22	1.5460	0.6468	27.2990	0.0366	17.6580	0.0566
23	1.5769	0.6342	28.8450	0.0347	18.2922	0.0547
24	1.6084	0.6217	30.4219	0.0329	18.9139	0.0529
25	1.6406	0.6095	32.0303	0.0312	19.5235	0.0512
26	1.6734	0.5976	33.6709	0.0297	20.1210	0.0497
27	1.7069	0.5859	35.3443	0.0283	20.7069	0.0483
28	1.7410	0.5744	37.0512	0.0270	21.2813	0.0470
29	1.7758	0.5631	38.7922	0.0258	21.8444	0.0458
30	1.8114	0.5521	40.5681	0.0246	22.3965	0.0446
31	1.8476	0.5412	42.3794	0.0236	22.9377	0.0436
32	1.8845	0.5306	44.2270	0.0226	23.4683	0.0426
33	1.9222	0.5202	46.1116	0.0217	23.9886	0.0417
34	1.9607	0.5100	48.0338	0.0208	24.4986	0.0408
35	1.9999	0.5000	49.9945	0.0200	24.9986	0.0400
36	2.0399	0.4902	51.9944	0.0192	25.4888	0.0392
37	2.0807	0.4806	54.0343	0.0185	25.9695	0.0385
38	2.1223	0.4712	56.1149	0.0178	26.4406	0.0378
39	2.1647	0.4619	58.2372	0.0172	26.9026	0.0372
40	2.2080	0.4529	60.4020	0.0166	27.3555	0.0366
45	2.4379	0.4102	71.8927	0.0139	29.4902	0.0339
48	2.5871	0.3865	79.3535	0.0126	30.6731	0.0326
50	2.6916	0.3715	84.5794	0.0118	31.4236	0.0318
54	2.9135	0.3432	95.6731	0.0105	32.8383	0.0305
60	3.2810	0.3048	114.0515	0.0088	34.7609	0.0288

Compound Interest Table for: $i = 3\%$

n	Single Payment		Uniform Series			
	Compound Amount Factor	Present Worth Factor	Compound Amount Factor	Sinking Fund Factor	Present Worth Factor	Capital Recovery Factor
	To find F when given a P (F/P, i, n)	To find P when given an F (P/F, i, n)	To find F when given an A (F/A, i, n)	To find A when given an F (A/F, i, n)	To find P when given an A (P/A, i, n)	To find A when given a P (A/P, i, n)
1	1.0300	0.9709	1.0000	1.0000	0.9709	1.0300
2	1.0609	0.9426	2.0300	0.4926	1.9135	0.5226
3	1.0927	0.9151	3.0909	0.3235	2.8286	0.3535
4	1.1255	0.8885	4.1836	0.2390	3.7171	0.2690
5	1.1593	0.8626	5.3091	0.1884	4.5797	0.2184
6	1.1941	0.8375	6.4684	0.1546	5.4172	0.1846
7	1.2299	0.8131	7.6625	0.1305	6.2303	0.1605
8	1.2668	0.7894	8.8923	0.1125	7.0197	0.1425
9	1.3048	0.7664	10.1591	0.0984	7.7861	0.1284
10	1.3439	0.7441	11.4639	0.0872	8.5302	0.1172
11	1.3842	0.7224	12.8078	0.0781	9.2526	0.1081
12	1.4258	0.7014	14.1920	0.0705	9.9540	0.1005
13	1.4685	0.6810	15.6178	0.0640	10.6350	0.0940
14	1.5126	0.6611	17.0863	0.0585	11.2961	0.0885
15	1.5580	0.6419	18.5989	0.0538	11.9379	0.0838
16	1.6047	0.6232	20.1569	0.0496	12.5611	0.0796
17	1.6528	0.6050	21.7616	0.0460	13.1661	0.0760
18	1.7024	0.5874	23.4144	0.0427	13.7535	0.0727
19	1.7535	0.5703	25.1169	0.0398	14.3238	0.0698
20	1.8061	0.5537	26.8704	0.0372	14.8775	0.0672
21	1.8603	0.5375	28.6765	0.0349	15.4150	0.0649
22	1.9161	0.5219	30.5368	0.0327	15.9369	0.0627
23	1.9736	0.5067	32.4529	0.0308	16.4436	0.0608
24	2.0328	0.4919	34.4265	0.0290	16.9355	0.0590
25	2.0938	0.4776	36.4593	0.0274	17.4131	0.0574
26	2.1566	0.4637	38.5530	0.0259	17.8768	0.0559
27	2.2213	0.4502	40.7096	0.0246	18.3270	0.0546
28	2.2879	0.4371	42.9309	0.0233	18.7641	0.0533
29	2.3566	0.4243	45.2189	0.0221	19.1885	0.0521
30	2.4273	0.4120	47.5754	0.0210	19.6004	0.0510
31	2.5001	0.4000	50.0027	0.0200	20.0004	0.0500
32	2.5751	0.3883	52.5028	0.0190	20.3888	0.0490
33	2.6523	0.3770	55.0778	0.0182	20.7658	0.0482
34	2.7319	0.3660	57.7302	0.0173	21.1318	0.0473
35	2.8139	0.3554	60.4621	0.0165	21.4872	0.0465
36	2.8983	0.3450	63.2759	0.0158	21.8323	0.0458
37	2.9852	0.3350	66.1742	0.0151	22.1672	0.0451
38	3.0746	0.3252	69.1594	0.0145	22.4925	0.0445
39	3.1670	0.3158	72.2342	0.0138	22.8082	0.0438
40	3.2620	0.3066	75.4013	0.0133	23.1148	0.0433
45	3.7816	0.2644	92.7199	0.0108	24.5187	0.0408
48	4.1323	0.2420	104.4084	0.0096	25.2667	0.0396
50	4.3839	0.2281	112.7969	0.0089	25.7298	0.0389
54	4.9341	0.2027	131.1375	0.0076	26.5777	0.0376
60	5.8916	0.1697	163.0534	0.0061	27.6756	0.0361

Compound Interest Table for: $i = 4\%$

n	Single Payment		Uniform Series			
	Compound Amount Factor	Present Worth Factor	Compound Amount Factor	Sinking Fund Factor	Present Worth Factor	Capital Recovery Factor
	To find F when given a P (F/P, i, n)	To find P when given an F (P/F, i, n)	To find F when given an A (F/A, i, n)	To find A when given an F (A/F, i, n)	To find P when given an A (P/A, i, n)	To find A when given a P (A/P, i, n)
1	1.0400	0.9615	1.0000	1.0000	0.9615	1.0400
2	1.0816	0.9246	2.0400	0.4902	1.8861	0.5302
3	1.1249	0.8890	3.1216	0.3203	2.7751	0.3603
4	1.1699	0.8548	4.2465	0.2355	3.6299	0.2755
5	1.2167	0.8219	5.4163	0.1846	4.4518	0.2246
6	1.2653	0.7903	6.6330	0.1508	5.2421	0.1908
7	1.3159	0.7599	7.8983	0.1266	6.0021	0.1666
8	1.3686	0.7307	9.2142	0.1085	6.7327	0.1485
9	1.4233	0.7026	10.5828	0.0945	7.4353	0.1345
10	1.4802	0.6756	12.0061	0.0833	8.1109	0.1233
11	1.5395	0.6496	13.4864	0.0741	8.7605	0.1141
12	1.6010	0.6246	15.0258	0.0666	9.3851	0.1066
13	1.6651	0.6006	16.6268	0.0601	9.9856	0.1001
14	1.7317	0.5775	18.2919	0.0547	10.5631	0.0947
15	1.8009	0.5553	20.0236	0.0499	11.1184	0.0899
16	1.8730	0.5339	21.8245	0.0458	11.6523	0.0858
17	1.9479	0.5134	23.6975	0.0422	12.1657	0.0822
18	2.0258	0.4936	25.6454	0.0390	12.6593	0.0790
19	2.1068	0.4746	27.6712	0.0361	13.1339	0.0761
20	2.1911	0.4564	29.7781	0.0336	13.5903	0.0736
21	2.2788	0.4388	31.9692	0.0313	14.0292	0.0713
22	2.3699	0.4220	34.2480	0.0292	14.4511	0.0692
23	2.4647	0.4057	36.6179	0.0273	14.8568	0.0673
24	2.5633	0.3901	39.0826	0.0256	15.2470	0.0656
25	2.6658	0.3751	41.6459	0.0240	15.6221	0.0640
26	2.7725	0.3607	44.3117	0.0226	15.9828	0.0626
27	2.8834	0.3468	47.0842	0.0212	16.3296	0.0612
28	2.9987	0.3335	49.9676	0.0200	16.6631	0.0600
29	3.1187	0.3207	52.9663	0.0189	16.9837	0.0589
30	3.2434	0.3083	56.0849	0.0178	17.2920	0.0578
31	3.3731	0.2965	59.3283	0.0169	17.5885	0.0569
32	3.5081	0.2851	62.7015	0.0159	17.8736	0.0559
33	3.6484	0.2741	66.2095	0.0151	18.1476	0.0551
34	3.7943	0.2636	69.8579	0.0143	18.4112	0.0543
35	3.9461	0.2534	73.6522	0.0136	18.6646	0.0536
36	4.1039	0.2437	77.5983	0.0129	18.9083	0.0529
37	4.2681	0.2343	81.7022	0.0122	19.1426	0.0522
38	4.4388	0.2253	85.9703	0.0116	19.3679	0.0516
39	4.6164	0.2166	90.4091	0.0111	19.5845	0.0511
40	4.8010	0.2083	95.0255	0.0105	19.7928	0.0505
45	5.8412	0.1712	121.0294	0.0083	20.7200	0.0483
48	6.5705	0.1522	139.2632	0.0072	21.1951	0.0472
50	7.1067	0.1407	152.6671	0.0066	21.4822	0.0466
54	8.3138	0.1203	182.8454	0.0055	21.9930	0.0455
60	10.5196	0.0951	237.9907	0.0042	22.6235	0.0442

Compound Interest Table for: $i = 5\%$

n	Single Payment		Uniform Series			
	Compound Amount Factor	Present Worth Factor	Compound Amount Factor	Sinking Fund Factor	Present Worth Factor	Capital Recovery Factor
	To find F when given a P (F/P, i, n)	To find P when given an F (P/F, i, n)	To find F when given an A (F/A, i, n)	To find A when given an F (A/F, i, n)	To find P when given an A (P/A, i, n)	To find A when given a P (A/P, i, n)
1	1.0500	0.9524	1.0000	1.0000	0.9524	1.0500
2	1.1025	0.9070	2.0500	0.4878	1.8594	0.5378
3	1.1576	0.8638	3.1525	0.3172	2.7232	0.3672
4	1.2155	0.8227	4.3101	0.2320	3.5460	0.2820
5	1.2763	0.7835	5.5256	0.1810	4.3295	0.2310
6	1.3401	0.7462	6.8019	0.1470	5.0757	0.1970
7	1.4071	0.7107	8.1420	0.1228	5.7864	0.1728
8	1.4775	0.6768	9.5491	0.1047	6.4632	0.1547
9	1.5513	0.6446	11.0266	0.0907	7.1078	0.1407
10	1.6289	0.6139	12.5779	0.0795	7.7217	0.1295
11	1.7103	0.5847	14.2068	0.0704	8.3064	0.1204
12	1.7959	0.5568	15.9171	0.0628	8.8633	0.1128
13	1.8856	0.5303	17.7130	0.0565	9.3936	0.1065
14	1.9799	0.5051	19.5986	0.0510	9.8986	0.1010
15	2.0789	0.4810	21.5786	0.0463	10.3797	0.0963
16	2.1829	0.4581	23.6575	0.0423	10.8378	0.0923
17	2.2920	0.4363	25.8404	0.0387	11.2741	0.0887
18	2.4066	0.4155	28.1324	0.0355	11.6896	0.0855
19	2.5270	0.3957	30.5390	0.0327	12.0853	0.0827
20	2.6533	0.3769	33.0660	0.0302	12.4622	0.0802
21	2.7860	0.3589	35.7193	0.0280	12.8212	0.0780
22	2.9253	0.3418	38.5052	0.0260	13.1630	0.0760
23	3.0715	0.3256	41.4305	0.0241	13.4886	0.0741
24	3.2251	0.3101	44.5020	0.0225	13.7986	0.0725
25	3.3864	0.2953	47.7271	0.0210	14.0939	0.0710
26	3.5557	0.2812	51.1135	0.0196	14.3752	0.0696
27	3.7335	0.2678	54.6691	0.0183	14.6430	0.0683
28	3.9201	0.2551	58.4026	0.0171	14.8981	0.0671
29	4.1161	0.2429	62.3227	0.0160	15.1411	0.0660
30	4.3219	0.2314	66.4388	0.0151	15.3725	0.0651
31	4.5380	0.2204	70.7608	0.0141	15.5928	0.0641
32	4.7649	0.2099	75.2988	0.0133	15.8027	0.0633
33	5.0032	0.1999	80.0638	0.0125	16.0025	0.0625
34	5.2533	0.1904	85.0670	0.0118	16.1929	0.0618
35	5.5160	0.1813	90.3203	0.0111	16.3742	0.0611
36	5.7918	0.1727	95.8363	0.0104	16.5469	0.0604
37	6.0814	0.1644	101.6281	0.0098	16.7113	0.0598
38	6.3855	0.1566	107.7095	0.0093	16.8679	0.0593
39	6.7048	0.1491	114.0950	0.0088	17.0170	0.0588
40	7.0400	0.1420	120.7998	0.0083	17.1591	0.0583
45	8.9850	0.1113	159.7002	0.0063	17.7741	0.0563
48	10.4013	0.0961	188.0254	0.0053	18.0772	0.0553
50	11.4674	0.0872	209.3480	0.0048	18.2559	0.0548
54	13.9387	0.0717	258.7739	0.0039	18.5651	0.0539
60	18.6792	0.0535	353.5837	0.0028	18.9293	0.0528

Compound Interest Table for: $i = 6\%$

n	Single Payment		Uniform Series			
	Compound Amount Factor	Present Worth Factor	Compound Amount Factor	Sinking Fund Factor	Present Worth Factor	Capital Recovery Factor
	To find F when given a P (F/P, i, n)	To find P when given an F (P/F, i, n)	To find F when given an A (F/A, i, n)	To find A when given an F (A/F, i, n)	To find P when given an A (P/A, i, n)	To find A when given a P (A/P, i, n)
1	1.0600	0.9434	1.0000	1.0000	0.9434	1.0600
2	1.1236	0.8900	2.0600	0.4854	1.8334	0.5454
3	1.1910	0.8396	3.1836	0.3141	2.6730	0.3741
4	1.2625	0.7921	4.3746	0.2286	3.4651	0.2886
5	1.3382	0.7473	5.6371	0.1774	4.2124	0.2374
6	1.4185	0.7050	6.9753	0.1434	4.9173	0.2034
7	1.5036	0.6651	8.3938	0.1191	5.5824	0.1791
8	1.5938	0.6274	9.8975	0.1010	6.2098	0.1610
9	1.6895	0.5919	11.4913	0.0870	6.8017	0.1470
10	1.7908	0.5584	13.1808	0.0759	7.3601	0.1359
11	1.8983	0.5268	14.9716	0.0668	7.8869	0.1268
12	2.0122	0.4970	16.8699	0.0593	8.3838	0.1193
13	2.1329	0.4688	18.8821	0.0530	8.8527	0.1130
14	2.2609	0.4423	21.0151	0.0476	9.2950	0.1076
15	2.3966	0.4173	23.2760	0.0430	9.7122	0.1030
16	2.5404	0.3936	25.6725	0.0390	10.1059	0.0990
17	2.6928	0.3714	28.2129	0.0354	10.4773	0.0954
18	2.8543	0.3503	30.9057	0.0324	10.8276	0.0924
19	3.0256	0.3305	33.7600	0.0296	11.1581	0.0896
20	3.2071	0.3118	36.7856	0.0272	11.4699	0.0872
21	3.3996	0.2942	39.9927	0.0250	11.7641	0.0850
22	3.6035	0.2775	43.3923	0.0230	12.0416	0.0830
23	3.8197	0.2618	46.9958	0.0213	12.3034	0.0813
24	4.0489	0.2470	50.8156	0.0197	12.5504	0.0797
25	4.2919	0.2330	54.8645	0.0182	12.7834	0.0782
26	4.5494	0.2198	59.1564	0.0169	13.0032	0.0769
27	4.8223	0.2074	63.7058	0.0157	13.2105	0.0757
28	5.1117	0.1956	68.5281	0.0146	13.4062	0.0746
29	5.4184	0.1846	73.6398	0.0136	13.5907	0.0736
30	5.7435	0.1741	79.0582	0.0126	13.7648	0.0726
31	6.0881	0.1643	84.8017	0.0118	13.9291	0.0718
32	6.4534	0.1550	90.8898	0.0110	14.0840	0.0710
33	6.8406	0.1462	97.3432	0.0103	14.2302	0.0703
34	7.2510	0.1379	104.1838	0.0096	14.3681	0.0696
35	7.6861	0.1301	111.4348	0.0090	14.4982	0.0690
36	8.1473	0.1227	119.1209	0.0084	14.6210	0.0684
37	8.6361	0.1158	127.2681	0.0079	14.7368	0.0679
38	9.1543	0.1092	135.9042	0.0074	14.8460	0.0674
39	9.7035	0.1031	145.0585	0.0069	14.9491	0.0669
40	10.2857	0.0972	154.7620	0.0065	15.0463	0.0665
45	13.7646	0.0727	212.7435	0.0047	15.4558	0.0647
48	16.3939	0.0610	256.5645	0.0039	15.6500	0.0639
50	18.4202	0.0543	290.3359	0.0034	15.7619	0.0634
54	23.2550	0.0430	370.9170	0.0027	15.9500	0.0627
60	32.9877	0.0303	533.1282	0.0019	16.1614	0.0619

Compound Interest Table for: $i = 7\%$

n	Single Payment		Uniform Series			
	Compound Amount Factor	Present Worth Factor	Compound Amount Factor	Sinking Fund Factor	Present Worth Factor	Capital Recovery Factor
	To find F when given a P (F/P, i, n)	To find P when given an F (P/F, i, n)	To find F when given an A (F/A, i, n)	To find A when given an F (A/F, i, n)	To find P when given an A (P/A, i, n)	To find A when given a P (A/P, i, n)
1	1.0700	0.9346	1.0000	1.0000	0.9346	1.0700
2	1.1449	0.8734	2.0700	0.4831	1.8080	0.5531
3	1.2250	0.8163	3.2149	0.3111	2.6243	0.3811
4	1.3108	0.7629	4.4399	0.2252	3.3872	0.2952
5	1.4026	0.7130	5.7507	0.1739	4.1002	0.2439
6	1.5007	0.6663	7.1533	0.1398	4.7665	0.2098
7	1.6058	0.6227	8.6540	0.1156	5.3893	0.1856
8	1.7182	0.5820	10.2598	0.0975	5.9713	0.1675
9	1.8385	0.5439	11.9780	0.0835	6.5152	0.1535
10	1.9672	0.5083	13.8164	0.0724	7.0236	0.1424
11	2.1049	0.4751	15.7836	0.0634	7.4987	0.1334
12	2.2522	0.4440	17.8885	0.0559	7.9427	0.1259
13	2.4098	0.4150	20.1406	0.0497	8.3577	0.1197
14	2.5785	0.3878	22.5505	0.0443	8.7455	0.1143
15	2.7590	0.3624	25.1290	0.0398	9.1079	0.1098
16	2.9522	0.3387	27.8881	0.0359	9.4466	0.1059
17	3.1588	0.3166	30.8402	0.0324	9.7632	0.1024
18	3.3799	0.2959	33.9990	0.0294	10.0591	0.0994
19	3.6165	0.2765	37.3790	0.0268	10.3356	0.0968
20	3.8697	0.2584	40.9955	0.0244	10.5940	0.0944
21	4.1406	0.2415	44.8652	0.0223	10.8355	0.0923
22	4.4304	0.2257	49.0057	0.0204	11.0612	0.0904
23	4.7405	0.2109	53.4361	0.0187	11.2722	0.0887
24	5.0724	0.1971	58.1767	0.0172	11.4693	0.0872
25	5.4274	0.1842	63.2490	0.0158	11.6536	0.0858
26	5.8074	0.1722	68.6765	0.0146	11.8258	0.0846
27	6.2139	0.1609	74.4838	0.0134	11.9867	0.0834
28	6.6488	0.1504	80.6977	0.0124	12.1371	0.0824
29	7.1143	0.1406	87.3465	0.0114	12.2777	0.0814
30	7.6123	0.1314	94.4608	0.0106	12.4090	0.0806
31	8.1451	0.1228	102.0730	0.0098	12.5318	0.0798
32	8.7153	0.1147	110.2182	0.0091	12.6466	0.0791
33	9.3253	0.1072	118.9334	0.0084	12.7538	0.0784
34	9.9781	0.1002	128.2588	0.0078	12.8540	0.0778
35	10.6766	0.0937	138.2369	0.0072	12.9477	0.0772
36	11.4239	0.0875	148.9135	0.0067	13.0352	0.0767
37	12.2236	0.0818	160.3374	0.0062	13.1170	0.0762
38	13.0793	0.0765	172.5610	0.0058	13.1935	0.0758
39	13.9948	0.0715	185.6403	0.0054	13.2649	0.0754
40	14.9745	0.0668	199.6351	0.0050	13.3317	0.0750
45	21.0025	0.0476	285.7493	0.0035	13.6055	0.0735
48	25.7289	0.0389	353.2701	0.0028	13.7305	0.0728
50	29.4570	0.0339	406.5289	0.0025	13.8007	0.0725
54	38.6122	0.0259	537.3164	0.0019	13.9157	0.0719
60	57.9464	0.0173	813.5204	0.0012	14.0392	0.0712

Compound Interest Table for: $i = 8\%$

n	Single Payment		Uniform Series			
	Compound Amount Factor	Present Worth Factor	Compound Amount Factor	Sinking Fund Factor	Present Worth Factor	Capital Recovery Factor
	To find F when given a P (F/P, i, n)	To find P when given an F (P/F, i, n)	To find F when given an A (F/A, i, n)	To find A when given an F (A/F, i, n)	To find P when given an A (P/A, i, n)	To find A when given a P (A/P, i, n)
1	1.0800	0.9259	1.0000	1.0000	0.9259	1.0800
2	1.1664	0.8573	2.0800	0.4808	1.7833	0.5608
3	1.2597	0.7938	3.2464	0.3080	2.5771	0.3880
4	1.3605	0.7350	4.5061	0.2219	3.3121	0.3019
5	1.4693	0.6806	5.8666	0.1705	3.9927	0.2505
6	1.5869	0.6302	7.3359	0.1363	4.6229	0.2163
7	1.7138	0.5835	8.9228	0.1121	5.2064	0.1921
8	1.8509	0.5403	10.6366	0.0940	5.7466	0.1740
9	1.9990	0.5002	12.4876	0.0801	6.2469	0.1601
10	2.1589	0.4632	14.4866	0.0690	6.7101	0.1490
11	2.3316	0.4289	16.6455	0.0601	7.1390	0.1401
12	2.5182	0.3971	18.9771	0.0527	7.5361	0.1327
13	2.7196	0.3677	21.4953	0.0465	7.9038	0.1265
14	2.9372	0.3405	24.2149	0.0413	8.2442	0.1213
15	3.1722	0.3152	27.1521	0.0368	8.5595	0.1168
16	3.4259	0.2919	30.3243	0.0330	8.8514	0.1130
17	3.7000	0.2703	33.7502	0.0296	9.1216	0.1096
18	3.9960	0.2502	37.4502	0.0267	9.3719	0.1067
19	4.3157	0.2317	41.4463	0.0241	9.6036	0.1041
20	4.6610	0.2145	45.7620	0.0219	9.8181	0.1019
21	5.0338	0.1987	50.4229	0.0198	10.0168	0.0998
22	5.4365	0.1839	55.4568	0.0180	10.2007	0.0980
23	5.8715	0.1703	60.8933	0.0164	10.3711	0.0964
24	6.3412	0.1577	66.7648	0.0150	10.5288	0.0950
25	6.8485	0.1460	73.1059	0.0137	10.6748	0.0937
26	7.3964	0.1352	79.9544	0.0125	10.8100	0.0925
27	7.9881	0.1252	87.3508	0.0114	10.9352	0.0914
28	8.6271	0.1159	95.3388	0.0105	11.0511	0.0905
29	9.3173	0.1073	103.9659	0.0096	11.1584	0.0896
30	10.0627	0.0994	113.2832	0.0088	11.2578	0.0888
31	10.8677	0.0920	123.3459	0.0081	11.3498	0.0881
32	11.7371	0.0852	134.2135	0.0075	11.4350	0.0875
33	12.6760	0.0789	145.9506	0.0069	11.5139	0.0869
34	13.6901	0.0730	158.6267	0.0063	11.5869	0.0863
35	14.7853	0.0676	172.3168	0.0058	11.6546	0.0858
36	15.9682	0.0626	187.1021	0.0053	11.7172	0.0853
37	17.2456	0.0580	203.0703	0.0049	11.7752	0.0849
38	18.6253	0.0537	220.3159	0.0045	11.8289	0.0845
39	20.1153	0.0497	238.9412	0.0042	11.8786	0.0842
40	21.7245	0.0460	259.0565	0.0039	11.9246	0.0839
45	31.9204	0.0313	386.5056	0.0026	12.1084	0.0826
48	40.2106	0.0249	490.1322	0.0020	12.1891	0.0820
50	46.9016	0.0213	573.7702	0.0017	12.2335	0.0817
54	63.8091	0.0157	785.1141	0.0013	12.3041	0.0813
60	101.2571	0.0099	1253.2133	0.0008	12.3766	0.0808

Compound Interest Table for: $i = 9\%$

n	Single Payment		Uniform Series			
	Compound Amount Factor	Present Worth Factor	Compound Amount Factor	Sinking Fund Factor	Present Worth Factor	Capital Recovery Factor
	To find F when given a P (F/P, i, n)	To find P when given an F (P/F, i, n)	To find F when given an A (F/A, i, n)	To find A when given an F (A/F, i, n)	To find P when given an A (P/A, i, n)	To find A when given a P (A/P, i, n)
1	1.0900	0.9174	1.0000	1.0000	0.9174	1.0900
2	1.1881	0.8417	2.0900	0.4785	1.7591	0.5685
3	1.2950	0.7722	3.2781	0.3051	2.5313	0.3951
4	1.4116	0.7084	4.5731	0.2187	3.2397	0.3087
5	1.5386	0.6499	5.9847	0.1671	3.8897	0.2571
6	1.6771	0.5963	7.5233	0.1329	4.4859	0.2229
7	1.8280	0.5470	9.2004	0.1087	5.0330	0.1987
8	1.9926	0.5019	11.0285	0.0907	5.5348	0.1807
9	2.1719	0.4604	13.0210	0.0768	5.9952	0.1668
10	2.3674	0.4224	15.1929	0.0658	6.4177	0.1558
11	2.5804	0.3875	17.5603	0.0569	6.8052	0.1469
12	2.8127	0.3555	20.1407	0.0497	7.1607	0.1397
13	3.0658	0.3262	22.9534	0.0436	7.4869	0.1336
14	3.3417	0.2992	26.0192	0.0384	7.7862	0.1284
15	3.6425	0.2745	29.3609	0.0341	8.0607	0.1241
16	3.9703	0.2519	33.0034	0.0303	8.3126	0.1203
17	4.3276	0.2311	36.9737	0.0270	8.5436	0.1170
18	4.7171	0.2120	41.3013	0.0242	8.7556	0.1142
19	5.1417	0.1945	46.0185	0.0217	8.9501	0.1117
20	5.6044	0.1784	51.1601	0.0195	9.1285	0.1095
21	6.1088	0.1637	56.7645	0.0176	9.2922	0.1076
22	6.6586	0.1502	62.8733	0.0159	9.4424	0.1059
23	7.2579	0.1378	69.5319	0.0144	9.5802	0.1044
24	7.9111	0.1264	76.7898	0.0130	9.7066	0.1030
25	8.6231	0.1160	84.7009	0.0118	9.8226	0.1018
26	9.3992	0.1064	93.3240	0.0107	9.9290	0.1007
27	10.2451	0.0976	102.7231	0.0097	10.0266	0.0997
28	11.1671	0.0895	112.9682	0.0089	10.1161	0.0989
29	12.1722	0.0822	124.1354	0.0081	10.1983	0.0981
30	13.2677	0.0754	136.3075	0.0073	10.2737	0.0973
31	14.4618	0.0691	149.5752	0.0067	10.3428	0.0967
32	15.7633	0.0634	164.0370	0.0061	10.4062	0.0961
33	17.1820	0.0582	179.8003	0.0056	10.4644	0.0956
34	18.7284	0.0534	196.9823	0.0051	10.5178	0.0951
35	20.4140	0.0490	215.7108	0.0046	10.5668	0.0946
36	22.2512	0.0449	236.1247	0.0042	10.6118	0.0942
37	24.2538	0.0412	258.3759	0.0039	10.6530	0.0939
38	26.4367	0.0378	282.6298	0.0035	10.6908	0.0935
39	28.8160	0.0347	309.0665	0.0032	10.7255	0.0932
40	31.4094	0.0318	337.8824	0.0030	10.7574	0.0930
45	48.3273	0.0207	525.8587	0.0019	10.8812	0.0919
48	62.5852	0.0160	684.2804	0.0015	10.9336	0.0915
50	74.3575	0.0134	815.0836	0.0012	10.9617	0.0912
54	104.9617	0.0095	1155.1301	0.0009	11.0053	0.0909
60	176.0313	0.0057	1944.7921	0.0005	11.0480	0.0905

Compound Interest Table for: $i = 10\%$

n	Single Payment		Uniform Series			
	Compound Amount Factor	Present Worth Factor	Compound Amount Factor	Sinking Fund Factor	Present Worth Factor	Capital Recovery Factor
	To find F when given a P (F/P, i, n)	To find P when given an F (P/F, i, n)	To find F when given an A (F/A, i, n)	To find A when given an F (A/F, i, n)	To find P when given an A (P/A, i, n)	To find A when given a P (A/P, i, n)
1	1.1000	0.9091	1.0000	1.0000	0.9091	1.1000
2	1.2100	0.8264	2.1000	0.4762	1.7355	0.5762
3	1.3310	0.7513	3.3100	0.3021	2.4869	0.4021
4	1.4641	0.6830	4.6410	0.2155	3.1699	0.3155
5	1.6105	0.6209	6.1051	0.1638	3.7908	0.2638
6	1.7716	0.5645	7.7156	0.1296	4.3553	0.2296
7	1.9487	0.5132	9.4872	0.1054	4.8684	0.2054
8	2.1436	0.4665	11.4359	0.0874	5.3349	0.1874
9	2.3579	0.4241	13.5795	0.0736	5.7590	0.1736
10	2.5937	0.3855	15.9374	0.0627	6.1446	0.1627
11	2.8531	0.3505	18.5312	0.0540	6.4951	0.1540
12	3.1384	0.3186	21.3843	0.0468	6.8137	0.1468
13	3.4523	0.2897	24.5227	0.0408	7.1034	0.1408
14	3.7975	0.2633	27.9750	0.0357	7.3667	0.1357
15	4.1772	0.2394	31.7725	0.0315	7.6061	0.1315
16	4.5950	0.2176	35.9497	0.0278	7.8237	0.1278
17	5.0545	0.1978	40.5447	0.0247	8.0216	0.1247
18	5.5599	0.1799	45.5992	0.0219	8.2014	0.1219
19	6.1159	0.1635	51.1591	0.0195	8.3649	0.1195
20	6.7275	0.1486	57.2750	0.0175	8.5136	0.1175
21	7.4002	0.1351	64.0025	0.0156	8.6487	0.1156
22	8.1403	0.1228	71.4027	0.0140	8.7715	0.1140
23	8.9543	0.1117	79.5430	0.0126	8.8832	0.1126
24	9.8497	0.1015	88.4973	0.0113	8.9847	0.1113
25	10.8347	0.0923	98.3471	0.0102	9.0770	0.1102
26	11.9182	0.0839	109.1818	0.0092	9.1609	0.1092
27	13.1100	0.0763	121.0999	0.0083	9.2372	0.1083
28	14.4210	0.0693	134.2099	0.0075	9.3066	0.1075
29	15.8631	0.0630	148.6309	0.0067	9.3696	0.1067
30	17.4494	0.0573	164.4940	0.0061	9.4269	0.1061
31	19.1943	0.0521	181.9434	0.0055	9.4790	0.1055
32	21.1138	0.0474	201.1378	0.0050	9.5264	0.1050
33	23.2252	0.0431	222.2515	0.0045	9.5694	0.1045
34	25.5477	0.0391	245.4767	0.0041	9.6086	0.1041
35	28.1024	0.0356	271.0244	0.0037	9.6442	0.1037
36	30.9127	0.0323	299.1268	0.0033	9.6765	0.1033
37	34.0039	0.0294	330.0395	0.0030	9.7059	0.1030
38	37.4043	0.0267	364.0434	0.0027	9.7327	0.1027
39	41.1448	0.0243	401.4478	0.0025	9.7570	0.1025
40	45.2593	0.0221	442.5926	0.0023	9.7791	0.1023
45	72.8905	0.0137	718.9048	0.0014	9.8628	0.1014
48	97.0172	0.0103	960.1723	0.0010	9.8969	0.1010
50	117.3909	0.0085	1163.9085	0.0009	9.9148	0.1009
54	171.8719	0.0058	1708.7195	0.0006	9.9418	0.1006
60	304.4816	0.0033	3034.8164	0.0003	9.9672	0.1003

Compound Interest Table for: $i = 12\%$

n	Single Payment		Uniform Series			
	Compound Amount Factor	Present Worth Factor	Compound Amount Factor	Sinking Fund Factor	Present Worth Factor	Capital Recovery Factor
	To find F when given a P (F/P, i, n)	To find P when given an F (P/F, i, n)	To find F when given an A (F/A, i, n)	To find A when given an F (A/F, i, n)	To find P when given an A (P/A, i, n)	To find A when given a P (A/P, i, n)
1	1.1200	0.8929	1.0000	1.0000	0.8929	1.1200
2	1.2544	0.7972	2.1200	0.4717	1.6901	0.5917
3	1.4049	0.7118	3.3744	0.2963	2.4018	0.4163
4	1.5735	0.6355	4.7793	0.2092	3.0373	0.3292
5	1.7623	0.5674	6.3528	0.1574	3.6048	0.2774
6	1.9738	0.5066	8.1152	0.1232	4.1114	0.2432
7	2.2107	0.4523	10.0890	0.0991	4.5638	0.2191
8	2.4760	0.4039	12.2997	0.0813	4.9676	0.2013
9	2.7731	0.3606	14.7757	0.0677	5.3282	0.1877
10	3.1058	0.3220	17.5487	0.0570	5.6502	0.1770
11	3.4785	0.2875	20.6546	0.0484	5.9377	0.1684
12	3.8960	0.2567	24.1331	0.0414	6.1944	0.1614
13	4.3635	0.2292	28.0291	0.0357	6.4235	0.1557
14	4.8871	0.2046	32.3926	0.0309	6.6282	0.1509
15	5.4736	0.1827	37.2797	0.0268	6.8109	0.1468
16	6.1304	0.1631	42.7533	0.0234	6.9740	0.1434
17	6.8660	0.1456	48.8837	0.0205	7.1196	0.1405
18	7.6900	0.1300	55.7497	0.0179	7.2497	0.1379
19	8.6128	0.1161	63.4397	0.0158	7.3658	0.1358
20	9.6463	0.1037	72.0524	0.0139	7.4694	0.1339
21	10.8038	0.0926	81.6987	0.0122	7.5620	0.1322
22	12.1003	0.0826	92.5026	0.0108	7.6446	0.1308
23	13.5523	0.0738	104.6029	0.0096	7.7184	0.1296
24	15.1786	0.0659	118.1552	0.0085	7.7843	0.1285
25	17.0001	0.0588	133.3339	0.0075	7.8431	0.1275
26	19.0401	0.0525	150.3339	0.0067	7.8957	0.1267
27	21.3249	0.0469	169.3740	0.0059	7.9426	0.1259
28	23.8839	0.0419	190.6989	0.0052	7.9844	0.1252
29	26.7499	0.0374	214.5828	0.0047	8.0218	0.1247
30	29.9599	0.0334	241.3327	0.0041	8.0552	0.1241
31	33.5551	0.0298	271.2926	0.0037	8.0850	0.1237
32	37.5817	0.0266	304.8477	0.0033	8.1116	0.1233
33	42.0915	0.0238	342.4294	0.0029	8.1354	0.1229
34	47.1425	0.0212	384.5210	0.0026	8.1566	0.1226
35	52.7996	0.0189	431.6635	0.0023	8.1755	0.1223
36	59.1356	0.0169	484.4631	0.0021	8.1924	0.1221
37	66.2318	0.0151	543.5987	0.0018	8.2075	0.1218
38	74.1797	0.0135	609.8305	0.0016	8.2210	0.1216
39	83.0812	0.0120	684.0102	0.0015	8.2330	0.1215
40	93.0510	0.0107	767.0914	0.0013	8.2438	0.1213
45	163.9876	0.0061	1358.2300	0.0007	8.2825	0.1207
48	230.3908	0.0043	1911.5898	0.0005	8.2972	0.1205
50	289.0022	0.0035	2400.0182	0.0004	8.3045	0.1204
54	454.7505	0.0022	3781.2545	0.0003	8.3150	0.1203
60	897.5969	0.0011	7471.6411	0.0001	8.3240	0.1201

Compound Interest Table for: $i = 15\%$

n	Single Payment		Uniform Series			
	Compound Amount Factor	Present Worth Factor	Compound Amount Factor	Sinking Fund Factor	Present Worth Factor	Capital Recovery Factor
	To find F when given a P (F/P, i, n)	To find P when given an F (P/F, i, n)	To find F when given an A (F/A, i, n)	To find A when given an F (A/F, i, n)	To find P when given an A (P/A, i, n)	To find A when given a P (A/P, i, n)
1	1.1500	0.8696	1.0000	1.0000	0.8696	1.1500
2	1.3225	0.7561	2.1500	0.4651	1.6257	0.6151
3	1.5209	0.6575	3.4725	0.2880	2.2832	0.4380
4	1.7490	0.5718	4.9934	0.2003	2.8550	0.3503
5	2.0114	0.4972	6.7424	0.1483	3.3522	0.2983
6	2.3131	0.4323	8.7537	0.1142	3.7845	0.2642
7	2.6600	0.3759	11.0668	0.0904	4.1604	0.2404
8	3.0590	0.3269	13.7268	0.0729	4.4873	0.2229
9	3.5179	0.2843	16.7858	0.0596	4.7716	0.2096
10	4.0456	0.2472	20.3037	0.0493	5.0188	0.1993
11	4.6524	0.2149	24.3493	0.0411	5.2337	0.1911
12	5.3503	0.1869	29.0017	0.0345	5.4206	0.1845
13	6.1528	0.1625	34.3519	0.0291	5.5831	0.1791
14	7.0757	0.1413	40.5047	0.0247	5.7245	0.1747
15	8.1371	0.1229	47.5804	0.0210	5.8474	0.1710
16	9.3576	0.1069	55.7175	0.0179	5.9542	0.1679
17	10.7613	0.0929	65.0751	0.0154	6.0472	0.1654
18	12.3755	0.0808	75.8364	0.0132	6.1280	0.1632
19	14.2318	0.0703	88.2118	0.0113	6.1982	0.1613
20	16.3665	0.0611	102.4436	0.0098	6.2593	0.1598
21	18.8215	0.0531	118.8101	0.0084	6.3125	0.1584
22	21.6447	0.0462	137.6316	0.0073	6.3587	0.1573
23	24.8915	0.0402	159.2764	0.0063	6.3988	0.1563
24	28.6252	0.0349	184.1678	0.0054	6.4338	0.1554
25	32.9190	0.0304	212.7930	0.0047	6.4641	0.1547
26	37.8568	0.0264	245.7120	0.0041	6.4906	0.1541
27	43.5353	0.0230	283.5688	0.0035	6.5135	0.1535
28	50.0656	0.0200	327.1041	0.0031	6.5335	0.1531
29	57.5755	0.0174	377.1697	0.0027	6.5509	0.1527
30	66.2118	0.0151	434.7451	0.0023	6.5660	0.1523
31	76.1435	0.0131	500.9569	0.0020	6.5791	0.1520
32	87.5651	0.0114	577.1005	0.0017	6.5905	0.1517
33	100.6998	0.0099	664.6655	0.0015	6.6005	0.1515
34	115.8048	0.0086	765.3654	0.0013	6.6091	0.1513
35	133.1755	0.0075	881.1702	0.0011	6.6166	0.1511
36	153.1519	0.0065	1014.3457	0.0010	6.6231	0.1510
37	176.1246	0.0057	1167.4975	0.0009	6.6288	0.1509
38	202.5433	0.0049	1343.6222	0.0007	6.6338	0.1507
39	232.9248	0.0043	1546.1655	0.0006	6.6380	0.1506
40	267.8635	0.0037	1779.0903	0.0006	6.6418	0.1506
45	538.7693	0.0019	3585.1285	0.0003	6.6543	0.1503
48	819.4007	0.0012	5456.0047	0.0002	6.6585	0.1502
50	1083.6574	0.0009	7217.7163	0.0001	6.6605	0.1501
54	1895.3236	0.0005	12628.8243	0.0001	6.6631	0.1501
60	4383.9987	0.0002	29219.9916	0.0000	6.6651	0.1500

Compound Interest Table for: $i = 18\%$

n	Single Payment		Uniform Series			
	Compound Amount Factor	Present Worth Factor	Compound Amount Factor	Sinking Fund Factor	Present Worth Factor	Capital Recovery Factor
	To find F when given a P (F/P, i, n)	To find P when given an F (P/F, i, n)	To find F when given an A (F/A, i, n)	To find A when given an F (A/F, i, n)	To find P when given an A (P/A, i, n)	To find A when given a P (A/P, i, n)
1	1.1800	0.8475	1.0000	1.0000	0.8475	1.1800
2	1.3924	0.7182	2.1800	0.4587	1.5656	0.6387
3	1.6430	0.6086	3.5724	0.2799	2.1743	0.4599
4	1.9388	0.5158	5.2154	0.1917	2.6901	0.3717
5	2.2878	0.4371	7.1542	0.1398	3.1272	0.3198
6	2.6996	0.3704	9.4420	0.1059	3.4976	0.2859
7	3.1855	0.3139	12.1415	0.0824	3.8115	0.2624
8	3.7589	0.2660	15.3270	0.0652	4.0776	0.2452
9	4.4355	0.2255	19.0859	0.0524	4.3030	0.2324
10	5.2338	0.1911	23.5213	0.0425	4.4941	0.2225
11	6.1759	0.1619	28.7551	0.0348	4.6560	0.2148
12	7.2876	0.1372	34.9311	0.0286	4.7932	0.2086
13	8.5994	0.1163	42.2187	0.0237	4.9095	0.2037
14	10.1472	0.0985	50.8180	0.0197	5.0081	0.1997
15	11.9737	0.0835	60.9653	0.0164	5.0916	0.1964
16	14.1290	0.0708	72.9390	0.0137	5.1624	0.1937
17	16.6722	0.0600	87.0680	0.0115	5.2223	0.1915
18	19.6733	0.0508	103.7403	0.0096	5.2732	0.1896
19	23.2144	0.0431	123.4135	0.0081	5.3162	0.1881
20	27.3930	0.0365	146.6280	0.0068	5.3527	0.1868
21	32.3238	0.0309	174.0210	0.0057	5.3837	0.1857
22	38.1421	0.0262	206.3448	0.0048	5.4099	0.1848
23	45.0076	0.0222	244.4868	0.0041	5.4321	0.1841
24	53.1090	0.0188	289.4945	0.0035	5.4509	0.1835
25	62.6686	0.0160	342.6035	0.0029	5.4669	0.1829
26	73.9490	0.0135	405.2721	0.0025	5.4804	0.1825
27	87.2598	0.0115	479.2211	0.0021	5.4919	0.1821
28	102.9666	0.0097	566.4809	0.0018	5.5016	0.1818
29	121.5005	0.0082	669.4475	0.0015	5.5098	0.1815
30	143.3706	0.0070	790.9480	0.0013	5.5168	0.1813
31	169.1774	0.0059	934.3186	0.0011	5.5227	0.1811
32	199.6293	0.0050	1103.4960	0.0009	5.5277	0.1809
33	235.5625	0.0042	1303.1253	0.0008	5.5320	0.1808
34	277.9638	0.0036	1538.6878	0.0006	5.5356	0.1806
35	327.9973	0.0030	1816.6516	0.0006	5.5386	0.1806
36	387.0368	0.0026	2144.6489	0.0005	5.5412	0.1805
37	456.7034	0.0022	2531.6857	0.0004	5.5434	0.1804
38	538.9100	0.0019	2988.3891	0.0003	5.5452	0.1803
39	635.9139	0.0016	3527.2992	0.0003	5.5468	0.1803
40	750.3783	0.0013	4163.2130	0.0002	5.5482	0.1802
45	1716.6839	0.0006	9531.5771	0.0001	5.5523	0.1801
48	2820.5665	0.0004	15664.2586	0.0001	5.5536	0.1801
50	3927.3569	0.0003	21813.0937	0.0000	5.5541	0.1800
54	7614.2721	0.0001	42295.9563	0.0000	5.5548	0.1800
60	20555.1400	0.0000	114189.6665	0.0000	5.5553	0.1800

Compound Interest Table for: $i = 20\%$

n	Single Payment		Uniform Series			
	Compound Amount Factor	Present Worth Factor	Compound Amount Factor	Sinking Fund Factor	Present Worth Factor	Capital Recovery Factor
	To find F when given a P (F/P, i, n)	To find P when given an F (P/F, i, n)	To find F when given an A (F/A, i, n)	To find A when given an F (A/F, i, n)	To find P when given an A (P/A, i, n)	To find A when given a P (A/P, i, n)
1	1.2000	0.8333	1.0000	1.0000	0.8333	1.2000
2	1.4400	0.6944	2.2000	0.4545	1.5278	0.6545
3	1.7280	0.5787	3.6400	0.2747	2.1065	0.4747
4	2.0736	0.4823	5.3680	0.1863	2.5887	0.3863
5	2.4883	0.4019	7.4416	0.1344	2.9906	0.3344
6	2.9860	0.3349	9.9299	0.1007	3.3255	0.3007
7	3.5832	0.2791	12.9159	0.0774	3.6046	0.2774
8	4.2998	0.2326	16.4991	0.0606	3.8372	0.2606
9	5.1598	0.1938	20.7989	0.0481	4.0310	0.2481
10	6.1917	0.1615	25.9587	0.0385	4.1925	0.2385
11	7.4301	0.1346	32.1504	0.0311	4.3271	0.2311
12	8.9161	0.1122	39.5805	0.0253	4.4392	0.2253
13	10.6993	0.0935	48.4966	0.0206	4.5327	0.2206
14	12.8392	0.0779	59.1959	0.0169	4.6106	0.2169
15	15.4070	0.0649	72.0351	0.0139	4.6755	0.2139
16	18.4884	0.0541	87.4421	0.0114	4.7296	0.2114
17	22.1861	0.0451	105.9306	0.0094	4.7746	0.2094
18	26.6233	0.0376	128.1167	0.0078	4.8122	0.2078
19	31.9480	0.0313	154.7400	0.0065	4.8435	0.2065
20	38.3376	0.0261	186.6880	0.0054	4.8696	0.2054
21	46.0051	0.0217	225.0256	0.0044	4.8913	0.2044
22	55.2061	0.0181	271.0307	0.0037	4.9094	0.2037
23	66.2474	0.0151	326.2369	0.0031	4.9245	0.2031
24	79.4968	0.0126	392.4842	0.0025	4.9371	0.2025
25	95.3962	0.0105	471.9811	0.0021	4.9476	0.2021
26	114.4755	0.0087	567.3773	0.0018	4.9563	0.2018
27	137.3706	0.0073	681.8528	0.0015	4.9636	0.2015
28	164.8447	0.0061	819.2233	0.0012	4.9697	0.2012
29	197.8136	0.0051	984.0680	0.0010	4.9747	0.2010
30	237.3763	0.0042	1181.8816	0.0008	4.9789	0.2008
31	284.8516	0.0035	1419.2579	0.0007	4.9824	0.2007
32	341.8219	0.0029	1704.1095	0.0006	4.9854	0.2006
33	410.1863	0.0024	2045.9314	0.0005	4.9878	0.2005
34	492.2235	0.0020	2456.1176	0.0004	4.9898	0.2004
35	590.6682	0.0017	2948.3411	0.0003	4.9915	0.2003
36	708.8019	0.0014	3539.0094	0.0003	4.9929	0.2003
37	850.5622	0.0012	4247.8112	0.0002	4.9941	0.2002
38	1020.6747	0.0010	5098.3735	0.0002	4.9951	0.2002
39	1224.8096	0.0008	6119.0482	0.0002	4.9959	0.2002
40	1469.7716	0.0007	7343.8578	0.0001	4.9966	0.2001
45	3657.2620	0.0003	18281.3099	0.0001	4.9986	0.2001
48	6319.7487	0.0002	31593.7436	0.0000	4.9992	0.2000
50	9100.4382	0.0001	45497.1908	0.0000	4.9995	0.2000
54	18870.6685	0.0001	94348.3427	0.0000	4.9997	0.2000
60	56347.5144	0.0000	281732.5718	0.0000	4.9999	0.2000

Compound Interest Table for: $i = 25\%$

n	Single Payment		Uniform Series			
	Compound Amount Factor	Present Worth Factor	Compound Amount Factor	Sinking Fund Factor	Present Worth Factor	Capital Recovery Factor
	To find F when given a P (F/P, i, n)	To find P when given an F (P/F, i, n)	To find F when given an A (F/A, i, n)	To find A when given an F (A/F, i, n)	To find P when given an A (P/A, i, n)	To find A when given a P (A/P, i, n)
1	1.2500	0.8000	1.0000	1.0000	0.8000	1.2500
2	1.5625	0.6400	2.2500	0.4444	1.4400	0.6944
3	1.9531	0.5120	3.8125	0.2623	1.9520	0.5123
4	2.4414	0.4096	5.7656	0.1734	2.3616	0.4234
5	3.0518	0.3277	8.2070	0.1218	2.6893	0.3718
6	3.8147	0.2621	11.2588	0.0888	2.9514	0.3388
7	4.7684	0.2097	15.0735	0.0663	3.1611	0.3163
8	5.9605	0.1678	19.8419	0.0504	3.3289	0.3004
9	7.4506	0.1342	25.8023	0.0388	3.4631	0.2888
10	9.3132	0.1074	33.2529	0.0301	3.5705	0.2801
11	11.6415	0.0859	42.5661	0.0235	3.6564	0.2735
12	14.5519	0.0687	54.2077	0.0184	3.7251	0.2684
13	18.1899	0.0550	68.7596	0.0145	3.7801	0.2645
14	22.7374	0.0440	86.9495	0.0115	3.8241	0.2615
15	28.4217	0.0352	109.6868	0.0091	3.8593	0.2591
16	35.5271	0.0281	138.1085	0.0072	3.8874	0.2572
17	44.4089	0.0225	173.6357	0.0058	3.9099	0.2558
18	55.5112	0.0180	218.0446	0.0046	3.9279	0.2546
19	69.3889	0.0144	273.5558	0.0037	3.9424	0.2537
20	86.7362	0.0115	342.9447	0.0029	3.9539	0.2529
21	108.4202	0.0092	429.6809	0.0023	3.9631	0.2523
22	135.5253	0.0074	538.1011	0.0019	3.9705	0.2519
23	169.4066	0.0059	673.6264	0.0015	3.9764	0.2515
24	211.7582	0.0047	843.0329	0.0012	3.9811	0.2512
25	264.6978	0.0038	1054.7912	0.0009	3.9849	0.2509
26	330.8722	0.0030	1319.4890	0.0008	3.9879	0.2508
27	413.5903	0.0024	1650.3612	0.0006	3.9903	0.2506
28	516.9879	0.0019	2063.9515	0.0005	3.9923	0.2505
29	646.2349	0.0015	2580.9394	0.0004	3.9938	0.2504
30	807.7936	0.0012	3227.1743	0.0003	3.9950	0.2503
31	1009.7420	0.0010	4034.9678	0.0002	3.9960	0.2502
32	1262.1774	0.0008	5044.7098	0.0002	3.9968	0.2502
33	1577.7218	0.0006	6306.8872	0.0002	3.9975	0.2502
34	1972.1523	0.0005	7884.6091	0.0001	3.9980	0.2501
35	2465.1903	0.0004	9856.7613	0.0001	3.9984	0.2501
36	3081.4879	0.0003	12321.9516	0.0001	3.9987	0.2501
37	3851.8599	0.0003	15403.4396	0.0001	3.9990	0.2501
38	4814.8249	0.0002	19255.2994	0.0001	3.9992	0.2501
39	6018.5311	0.0002	24070.1243	0.0000	3.9993	0.2500
40	7523.1638	0.0001	30088.6554	0.0000	3.9995	0.2500
45	22958.8740	0.0000	91831.4962	0.0000	3.9998	0.2500
48	44841.5509	0.0000	179362.2034	0.0000	3.9999	0.2500
50	70064.9232	0.0000	280255.6929	0.0000	3.9999	0.2500
54	171056.9414	0.0000	684223.7658	0.0000	4.0000	0.2500
60	652530.4468	0.0000	2610117.7872	0.0000	4.0000	0.2500

Compound Interest Table for: $i = 30\%$

n	Single Payment		Uniform Series			
	Compound Amount Factor	Present Worth Factor	Compound Amount Factor	Sinking Fund Factor	Present Worth Factor	Capital Recovery Factor
	To find F when given a P (F/P, i, n)	To find P when given an F (P/F, i, n)	To find F when given an A (F/A, i, n)	To find A when given an F (A/F, i, n)	To find P when given an A (P/A, i, n)	To find A when given a P (A/P, i, n)
1	1.3000	0.7692	1.0000	1.0000	0.7692	1.3000
2	1.6900	0.5917	2.3000	0.4348	1.3609	0.7348
3	2.1970	0.4552	3.9900	0.2506	1.8161	0.5506
4	2.8561	0.3501	6.1870	0.1616	2.1662	0.4616
5	3.7129	0.2693	9.0431	0.1106	2.4356	0.4106
6	4.8268	0.2072	12.7560	0.0784	2.6427	0.3784
7	6.2749	0.1594	17.5828	0.0569	2.8021	0.3569
8	8.1573	0.1226	23.8577	0.0419	2.9247	0.3419
9	10.6045	0.0943	32.0150	0.0312	3.0190	0.3312
10	13.7858	0.0725	42.8195	0.0235	3.0915	0.3235
11	17.9216	0.0558	56.4053	0.0177	3.1473	0.3177
12	23.2981	0.0429	74.3270	0.0135	3.1903	0.3135
13	30.2875	0.0330	97.6250	0.0102	3.2233	0.3102
14	39.3738	0.0254	127.9125	0.0078	3.2487	0.3078
15	51.1859	0.0195	167.2863	0.0060	3.2682	0.3060
16	66.5417	0.0150	218.4722	0.0046	3.2832	0.3046
17	86.5042	0.0116	285.0139	0.0035	3.2948	0.3035
18	112.4554	0.0089	371.5180	0.0027	3.3037	0.3027
19	146.1920	0.0068	483.9734	0.0021	3.3105	0.3021
20	190.0496	0.0053	630.1655	0.0016	3.3158	0.3016
21	247.0645	0.0040	820.2151	0.0012	3.3198	0.3012
22	321.1839	0.0031	1067.2796	0.0009	3.3230	0.3009
23	417.5391	0.0024	1388.4635	0.0007	3.3254	0.3007
24	542.8008	0.0018	1806.0026	0.0006	3.3272	0.3006
25	705.6410	0.0014	2348.8033	0.0004	3.3286	0.3004
26	917.3333	0.0011	3054.4443	0.0003	3.3297	0.3003
27	1192.5333	0.0008	3971.7776	0.0003	3.3305	0.3003
28	1550.2933	0.0006	5164.3109	0.0002	3.3312	0.3002
29	2015.3813	0.0005	6714.6042	0.0001	3.3317	0.3001
30	2619.9956	0.0004	8729.9855	0.0001	3.3321	0.3001
31	3405.9943	0.0003	11349.9811	0.0001	3.3324	0.3001
32	4427.7926	0.0002	14755.9755	0.0001	3.3326	0.3001
33	5756.1304	0.0002	19183.7681	0.0001	3.3328	0.3001
34	7482.9696	0.0001	24939.8985	0.0000	3.3329	0.3000
35	9727.8604	0.0001	32422.8681	0.0000	3.3330	0.3000
36	12646.2186	0.0001	42150.7285	0.0000	3.3331	0.3000
37	16440.0841	0.0001	54796.9471	0.0000	3.3331	0.3000
38	21372.1094	0.0000	71237.0312	0.0000	3.3332	0.3000
39	27783.7422	0.0000	92609.1405	0.0000	3.3332	0.3000
40	36118.8648	0.0000	120392.8827	0.0000	3.3332	0.3000
45	134106.8167	0.0000	447019.3890	0.0000	3.3333	0.3000
48	294632.6763	0.0000	982105.5877	0.0000	3.3333	0.3000
50	497929.2230	0.0000	1659760.7433	0.0000	3.3333	0.3000
54	1422135.6538	0.0000	4740448.8458	0.0000	3.3333	0.3000
60	6864377.1727	0.0000	22881253.9091	0.0000	3.3333	0.3000