



NRL/MR/7130--99-8324

# Sonar Dome Deflection Measurements on the USS RADFORD

JOEL F. COVEY  
ROBERT D. CORSARO

*Physical Acoustics Branch  
Acoustics Division*

DIANE B. WEAVER  
JONATHAN B. WALKER

*SFA, Inc.  
Largo, MD*

June 2, 1999

19990623 001

# REPORT DOCUMENTATION PAGE

*Form Approved*  
OMB No. 0704-0188

Public reporting burden for this collection of information is estimated to average 1 hour per response, including the time for reviewing instructions, searching existing data sources, gathering and maintaining the data needed, and completing and reviewing the collection of information. Send comments regarding this burden estimate or any other aspect of this collection of information, including suggestions for reducing this burden, to Washington Headquarters Services, Directorate for Information Operations and Reports, 1215 Jefferson Davis Highway, Suite 1204, Arlington, VA 22202-4302, and to the Office of Management and Budget, Paperwork Reduction Project (0704-0188), Washington, DC 20503.

1. AGENCY USE ONLY (Leave Blank)	2. REPORT DATE  June 2, 1999	3. REPORT TYPE AND DATES COVERED	
4. TITLE AND SUBTITLE  Sonar Dome Deflection Measurements on the USS RADFORD		5. FUNDING NUMBERS	
6. AUTHOR(S)  Joel F. Covey, Robert D. Corsaro, Diane B. Weaver,* and Jonathan B. Walker*			
7. PERFORMING ORGANIZATION NAME(S) AND ADDRESS(ES)  Naval Research Laboratory Washington, DC 20375-5320		8. PERFORMING ORGANIZATION REPORT NUMBER  NRL/MR/7135-99-8324	
9. SPONSORING/MONITORING AGENCY NAME(S) AND ADDRESS(ES)  NAVSEA PMS 411, Stan Silverstein 2531 Jefferson Davis Highway, 1 Crystal Park Suite 1102, Arlington, VA 22242-5169		10. SPONSORING/MONITORING AGENCY REPORT NUMBER	
11. SUPPLEMENTARY NOTES  *SFA, Inc. Largo, MD			
12a. DISTRIBUTION/AVAILABILITY STATEMENT  Approved for public release; distribution unlimited.		12b. DISTRIBUTION CODE  A	
13. ABSTRACT (Maximum 200 words)  Sonar dome deflection measurements were performed on the new monolithic sonar dome of the USS RADFORD in Oct.-Dec. 1997. Over 700 Mbytes of raw data from 22 environmental sensors and 128 displacement sensors were obtained. The at-sea data acquisition was highly successful with data collected over sea states 1 through 4, and for numerous ship speeds up to 31 knots. The analysis of this data has provided a more complete characterization of previously measured sonar dome deformations. Many new conclusions and observations on sonar dome behavior have been observed and correlated with ship motions.			
14. SUBJECT TERMS  Sonar dome Rubber window Monolithic dome		Acoustic time of flight Displacement measurement Wave height	15. NUMBER OF PAGES  285
17. SECURITY CLASSIFICATION OF REPORT  UNCLASSIFIED		18. SECURITY CLASSIFICATION OF THIS PAGE  UNCLASSIFIED	16. PRICE CODE
19. SECURITY CLASSIFICATION OF ABSTRACT  UNCLASSIFIED		20. LIMITATION OF ABSTRACT  UL	

## CONTENTS

EXECUTIVE SUMMARY .....	1
I. INTRODUCTION .....	10
II. SHIPBOARD .....	11
A. Installation .....	11
B. Measurement Plan .....	15
C. At Sea Measurements and Events .....	17
III. DATA COLLECTED .....	18
A. Data Set Summary .....	18
B. Scan Patterns .....	18
C. Data Processing .....	19
D. Environmental Data Display .....	21
E. Dome Centerline and -4 Foot Waterline Displays .....	22
F. 2D Contour Plots of the Dome Displacement .....	23
G. 3D Animation Display .....	25
IV. RESULTS AND DISCUSSION .....	25
V. CONCLUSIONS AND FUTURE PLANS .....	30
VI. ACKNOWLEDGMENTS .....	32
VII. APPENDICES .....	33
APPENDIX 1: Measured Environmental Parameters .....	34
APPENDIX 2: List of Data Files .....	35
APPENDIX 3: Hydrophone Position Displays .....	40
APPENDIX 4: Evolution of the Scan Pattern .....	44
APPENDIX 5: Environmental Data Sheets .....	48
APPENDIX 6: Centerline and Waterline Plots .....	172
APPENDIX 7: Contour Displacement Plots .....	247

## Executive Summary

# Sonar Dome Deflection Measurements on the USS RADFORD

Joel F. Covey, Robert D. Corsaro (NRL Code 7135),  
Diane B. Weaver, and Jonathan B. Walker (SFA Inc.)

Sonar dome deflection measurements were performed on the new monolithic sonar dome of the USS RADFORD in October 1997 to January 1998. Over 700 Mbytes of raw data from 22 environmental sensors and 150 displacement sensors were obtained. The at-sea data acquisition was highly successful with data collected over sea states 1 through 4, and for numerous ship speeds up to 31 knots.

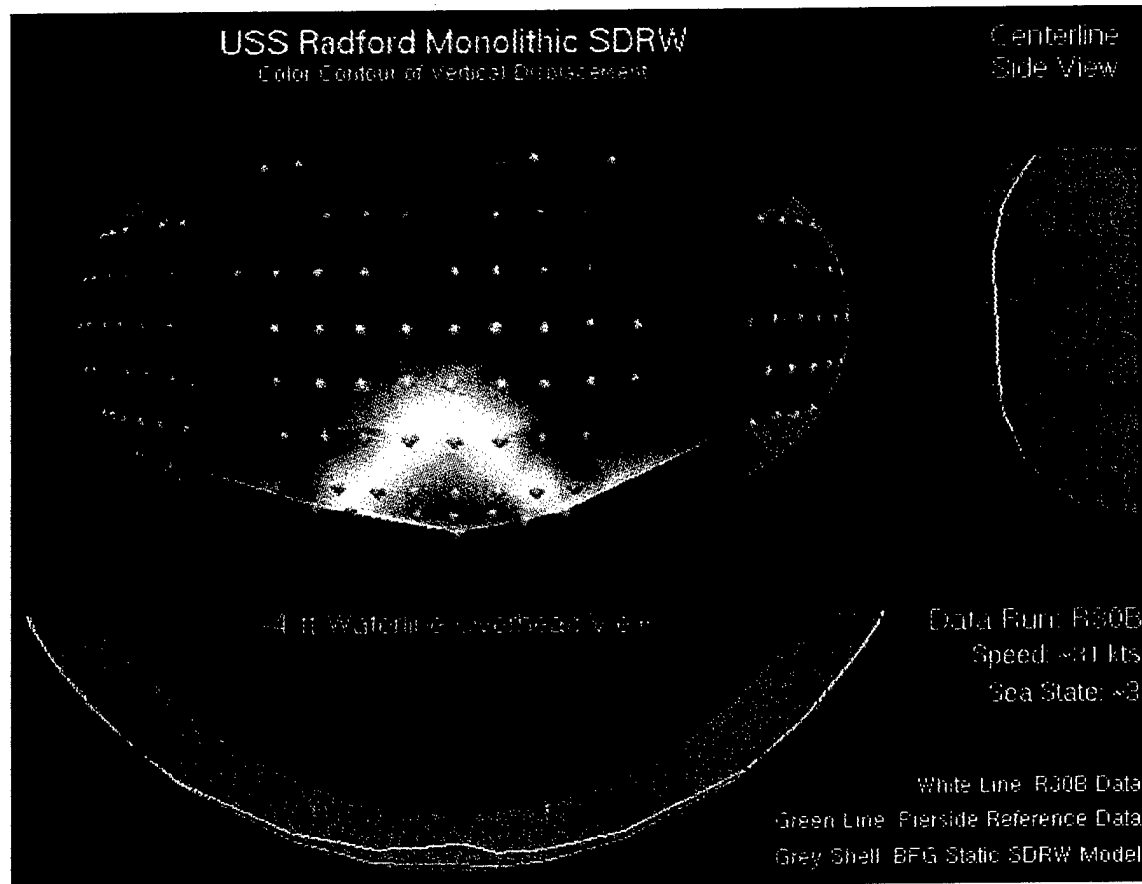

The analysis of this data relied strongly on 3-D visualization tools. One frame from the animation of one trial run is shown above. Each trial contains typically 200 such frames, and 234 sea trials were performed. This has resulted in an extensive data set that provides a more complete characterization of sonar dome deformations than previously possible.

## New Observations and Behaviors

New conclusions and observations on sonar dome behavior have been observed and correlated with ship motions as summarized below:

(1) Centerline deformation was consistent with previous measurements, but larger in amplitude (maximum deformation observed was 5.27 inches at 31 knots). The deformation behavior of the centerline for the highest speed run (R30B at 31 knots) is shown in Figure 1. This shows that due to the force of the seaway, the upper part of the dome is displaced inwards (towards the sonar array), and the lower part bulges outwards.

**Figure 1. USS Radford SDRW Centerline Cross Section  
Data Run: R30B Speed: ~31kts Sea State: 3**

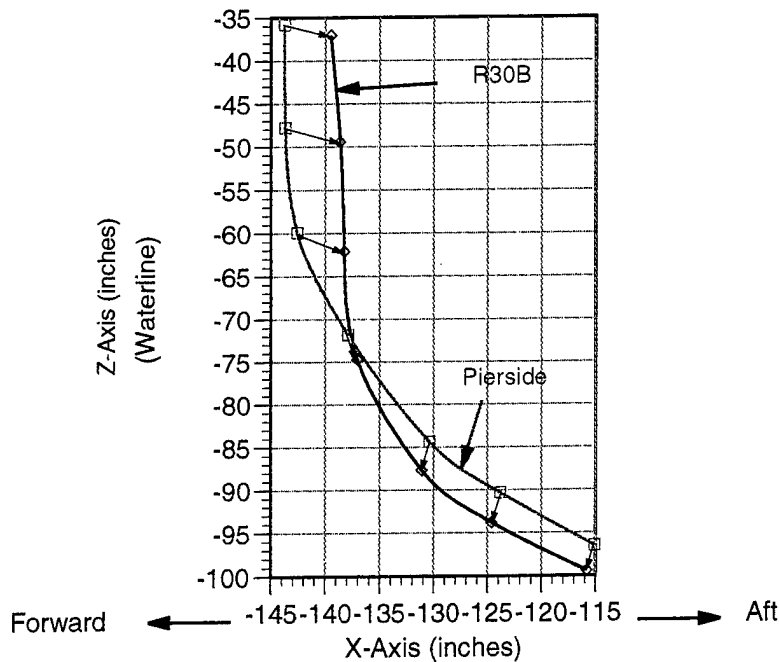

(2) Figure 1 also shows that the entire front section of the sonar dome was displaced downwards, with the largest downward displacement in the lower region.

(3) Figure 2 shows the -4 foot waterline deformation for the same data run at 31 knots.

(4) A depression was observed (at high speed) around the upper centerline (for approximately 20 inches). This feature can be clearly seen in Figure 2 and also in the contour plot of Figure 3.

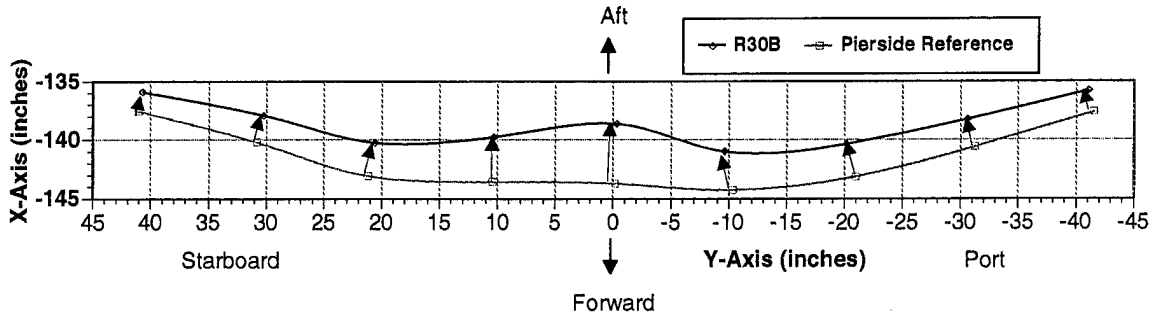

**Figure 2. USS Radford SDRW -4ft Waterline Cross Sectional View About the Centerline**  
**Data Run: R30B Speed: ~31kts Sea State: 3**

(5) The inward deformation of the upper front part of the dome (shown in magenta in Figure 3) is compensated by the outward deformation of the lower front and the slight outward deformation of the sides of the dome (shown in cyan). The incompressibility of the water filled sonar dome requires that any deformations be such as to conserve the total volume.

(6) There is an overall downward deformation of the entire dome (seen in the second plot in Figure 3), with the front of the dome experiencing the largest shift downwards. This shows that the downward displacement noted above in item (2) for the front part of the dome applies globally to the entire sonar dome.

**Figure 3: USS Radford SDRW Deflection Color Contour Plots**

**Data Run: R30B**

**Avg. Ship Speed: ~31 kts    Sea State: 3**

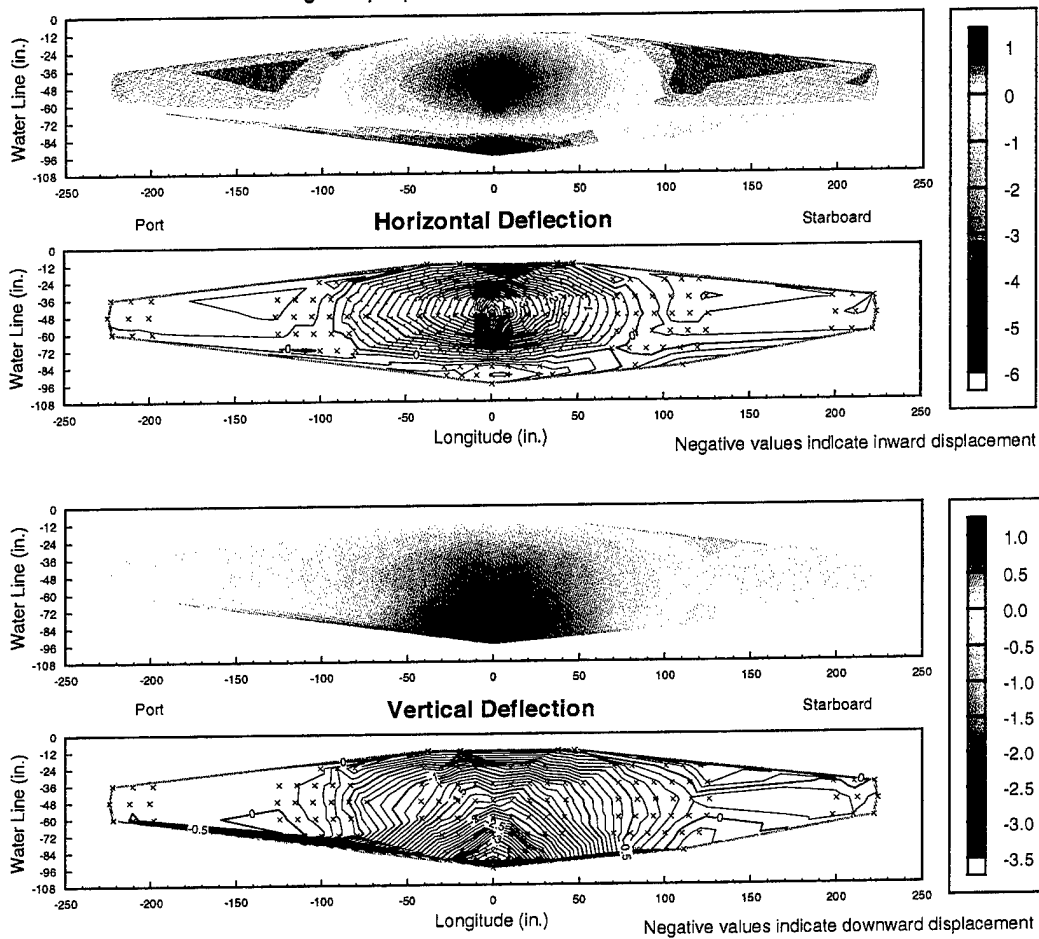

(7) The magnitude of dome deflection is primarily determined by the force of the seaway. This can be seen in Figure 4, where data from 100 at-sea data sets are plotted as a function of ship speed and sea state.

**Figure 4. USS Radford SDRW Static Deflections vs. Ship Speed  
(Linear Scale)**

Deflections at Intersection of -4ft Waterline and Centerline Referenced to Pierside Data

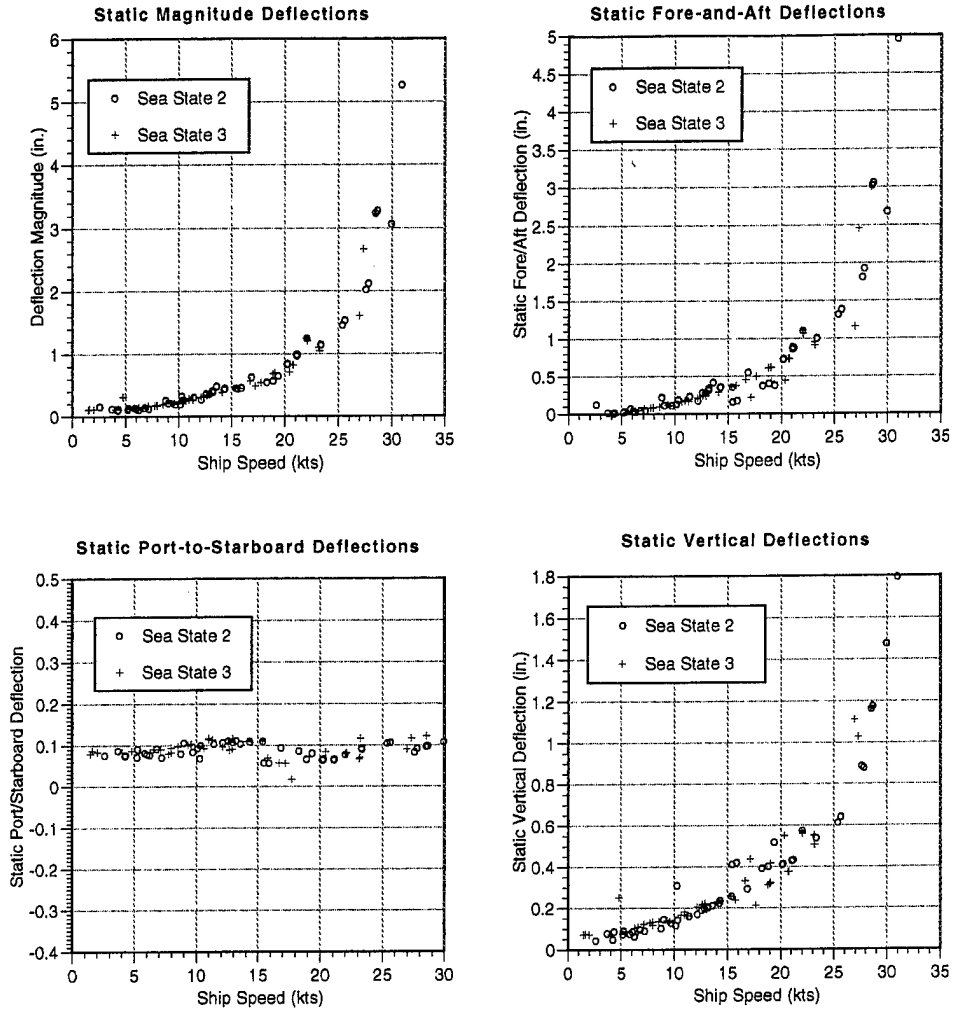

(8) The exponential nature of the deformation vs. ship speed is clearly visible when this data is re-plotted on Log/linear scale, as in Figure 5. A numerical fit to Figure 5 is:

$$D = 0.6 * \text{Exp}(0.14 * S)$$

where D is the magnitude of the dome deflection in inches at a ship speed of S in knots.



(9) Figure 5 (and the numerical relationship above) shows that the magnitude of the deformation doubles approximately every 5 knots. The implications of this relationship imply that at high ship speeds the structural strain inside the sonar dome increases exponentially.

**Figure 5. USS Radford SDRW Static Deflections vs. Ship Speed**  
(Log/Linear Scale)

Deflections at Intersection of -4 foot Waterline and Centerline Referenced to Pierside Data

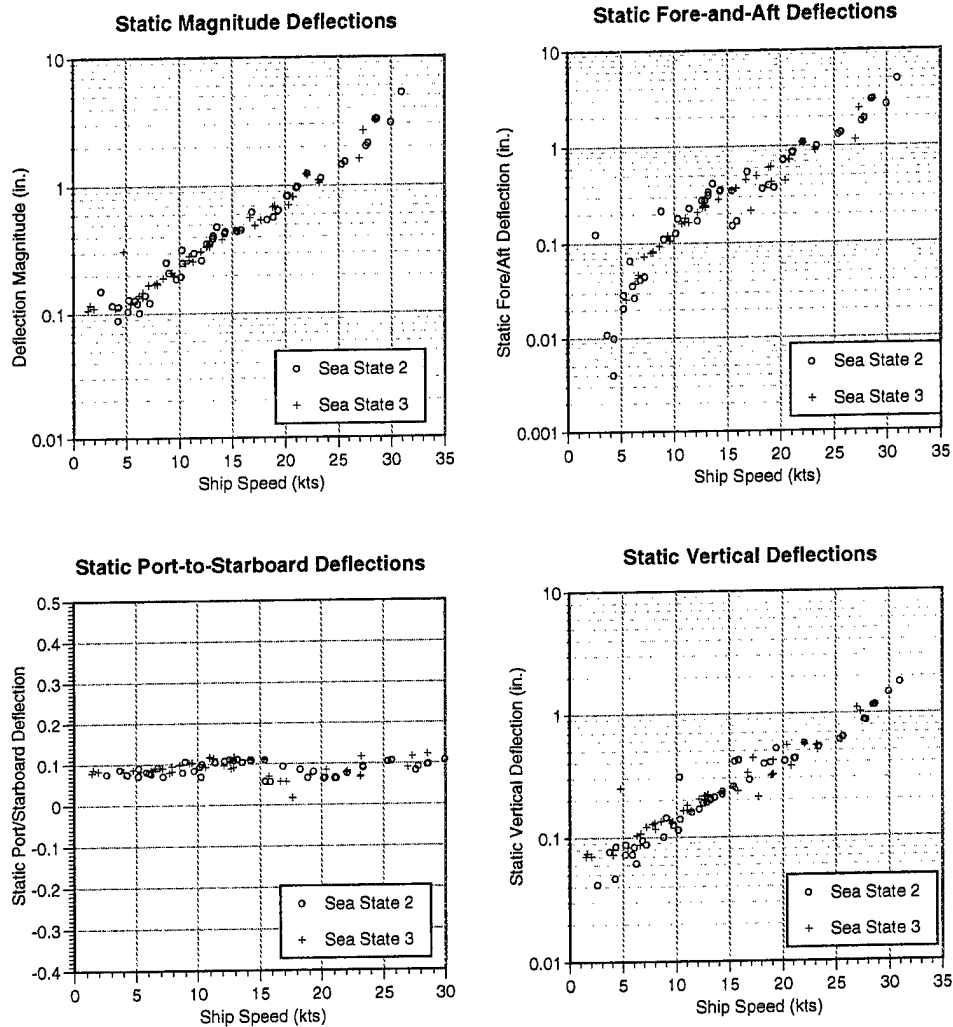

Note: Positive values indicate downward displacement.

(10) Figures 4 and 5 also show that, within the limited range of sea states measured, the deflection magnitude did not depend significantly on sea state.

(11) An increase in ship speed increases the dome internal pressure (nominally 0.25 PSI per knot), best seen in the data from the single data record Rlm28a during which the ship speed changed from 15 to 28 knots. Figure 6 shows this record as well as the average dome pressure for several other data runs.

**Figure 6. USS Radford SDRW Static Pressure vs. Ship Speed**

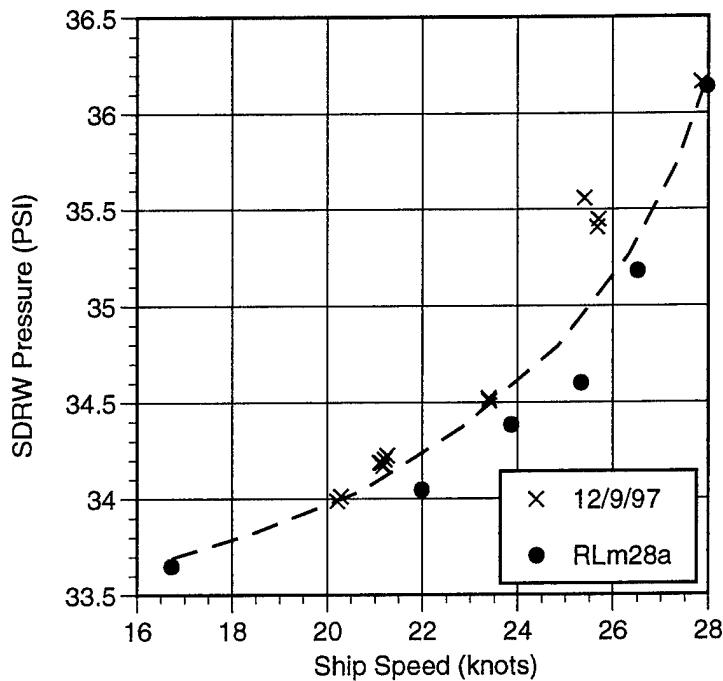

(12) In examining the environmental parameters for correlation to dome deformation, the greatest effect (besides ship speed) appears to be caused by the vertical acceleration of the ship. The vertical motion of the ship causes oscillatory dome deformations, which also cause internal dome pressure fluctuations. Figure 7 shows a sample set (data run RL28a) of some of the environmental parameters measured during each data run.

# Figure 7. Sample Data

Data Run: RL28a

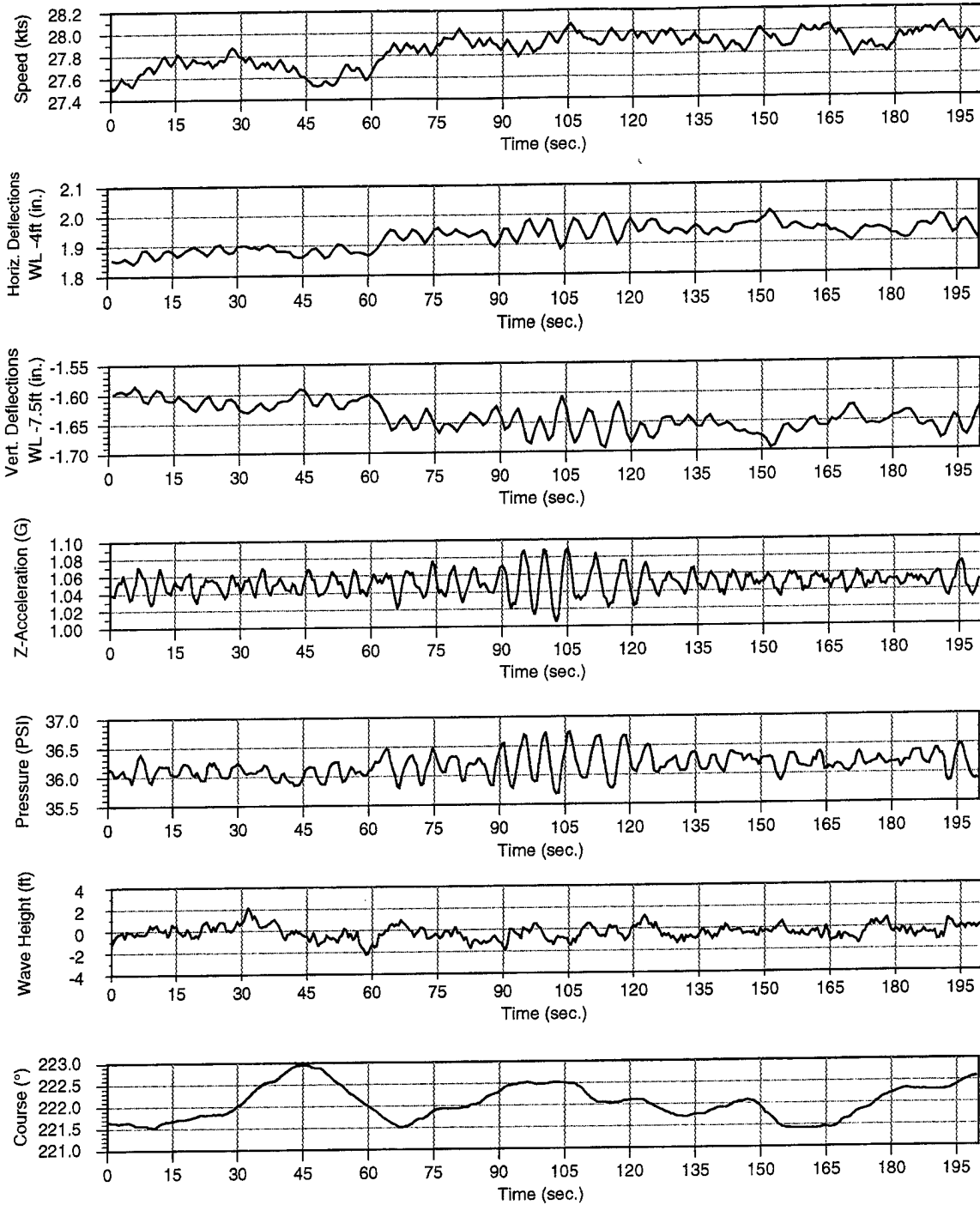

## **Correlation of Dynamics**

Data run RL28a was selected for Figure 7 because it optimally displays two different features of the environmental data. These two features are: (a) effects caused by significant speed changes, and (b) dynamic effects caused by other ship motions, such as roll, pitch, etc.

When the ship speed changes appreciably during a data run usually the change in dome deformation (and the other significant environmental parameters) is so large that the dynamic fluctuations are obscured by the scaling of the speed change effect. In RL28a the ship only increased speed by approximately 0.5 knot after the first 60 seconds of the data run. This speed change produces a noticeable increase in the horizontal deflection curve and an increased downwards (i.e. more negative) vertical deflection. Also noticeable is a slight increase, by approximately 0.25 PSI, in the average pressure. Thus, this data run is particularly interesting in that, the speed change is just large enough to demonstrate its influence on the other parameters, but without obscuring the dynamic aspects of the data independent of ship speed.

The dynamic effects are still clearly discernible in Figure 7 and show the correlation between vertical (i.e. Z) acceleration, pressure, and the horizontal and vertical deflections. This is most apparent in the time interval between 90 and 120 seconds where the largest dynamic oscillations occur. Notice that there is no visible correlation between the above parameters and the dynamic parts of the wave height, ship speed, and ship course data.

---

## I. INTRODUCTION

---

This report presents surface deflection measurements and results for the new monolithic Sonar Dome Rubber Window<sup>1</sup> (SDRW) under a wide variety of ship speed and sea state conditions. This dome was installed on the USS RADFORD<sup>2</sup> in August 1997. Measurements were conducted using the NRL Sonar Dome Strain and Deflection (SD2) Measurement System in sea and pier-side tests from October 1997 to January 1998. This system measured the position or displacement of the inner surface of the dome and a wide range of associated environmental parameters. It also simultaneously measured the output of strain gauges mounted by BFG on the wire cords inside the dome. All data was collected in real time as a function of sea-state and ship speed, direction and motion.

The Naval Research Laboratory (NRL) was responsible for the design, development, installation and use of the SD2 measurement system. The system consists of three subsystems: (1) deflection measurement, (2) environmental monitoring, and (3) strain gauge measurement. Only the results from the first two of these are discussed in this report. Results from the strain gauge measurement subsystem are to be presented separately by NRL Code 6100.

The deflection measurement subsystem is composed of 128 small projectors installed on the inner surface of the SDRW and 40 receiver hydrophones placed in fixed reference locations above and below the ship's sonar array. These transducers (projectors and receivers) are non-intrusive and do not interfere with normal ship SONAR operation. Using a time-of-flight acoustic technique, the separation distance between each projector and receiver combination can be precisely determined. Data from multiple receiver paths is then used to derive the absolute location (in three dimensions) of each projector, and hence the instantaneous coordinates of the corresponding location on the dome surface.

---

<sup>1</sup> designed and built by B. F. Goodrich of Jacksonville, FL.

<sup>2</sup> with the assistance of SFA Inc. and Geo-Centers personnel.

The environmental monitoring subsystem simultaneously recorded information using a dedicated on-board computer. A wide range of environmental parameters were measured including: the relative wave height of the seaway; the dome pressure; the roll and pitch of the ship; ship displacement relative to the sea; three-axis acceleration; and ship speed and course.

The following sections describe the system installation and sea tests. A brief description of the system and the data analysis procedure is included. The data sets collected are included in the Appendix of this report. A listing of all of the environmental parameters measured during each data run is given in **Appendix 1**. A complete list of all of the deflection data sets collected from the USS RADFORD is presented in **Appendix 2**.

---

## II. SHIPBOARD

---

### A. Installation

The NRL team installed the measurement system at the Norfolk Naval Shipyard in Portsmouth, VA. during the summer of 1997. **Figure 8** shows the layout of the sonar dome area. Included are the locations of the measurement system multiplexing components, the locations of the receiver hydrophone arrays, and the regions on the inner surface of the sonar dome which were equipped with the projector hydrophone displacement sensors. **Figure 9** shows a photograph of one of the smaller displacement sensor arrays containing only 9 hydrophones. **Figure 10** shows the sonar dome area (with the sonar dome removed) during the installation process. It includes a blowup showing some of the receiver hydrophone clips above the sonar array. The system multiplexing modules can be seen (in **Figure 10**) beneath the sonar array welded onto the banjo plate.

Two different maps showing the positions of all 128 hydrophone sensor locations on the inner surface of the sonar dome are included in **Appendix 3**. This appendix includes both a curved "artist" perspective drawing of the hydrophone arrays and a larger graph of the hydrophone locations as viewed after a 2D projection mapping of the sonar dome. This projection unwraps and flattens the sonar dome, giving a sense of the distortion produced. On the actual curved sonar dome the hydrophone locations were

- 58 Strain Billets
- 10 Receiver Hydrophone Banks  
40 Discrete Receiver Hydrophones
- 128 Acoustic Drivers  
47 Drivers each overlap 1 or 2 Strain Billets  
11 each over 2 Billets (4 LCM Type 1)  
36 each over 1 Billet (4 LCM Type 2)  
81 Drivers do not overlap any Strain Billets  
6 Star Modules

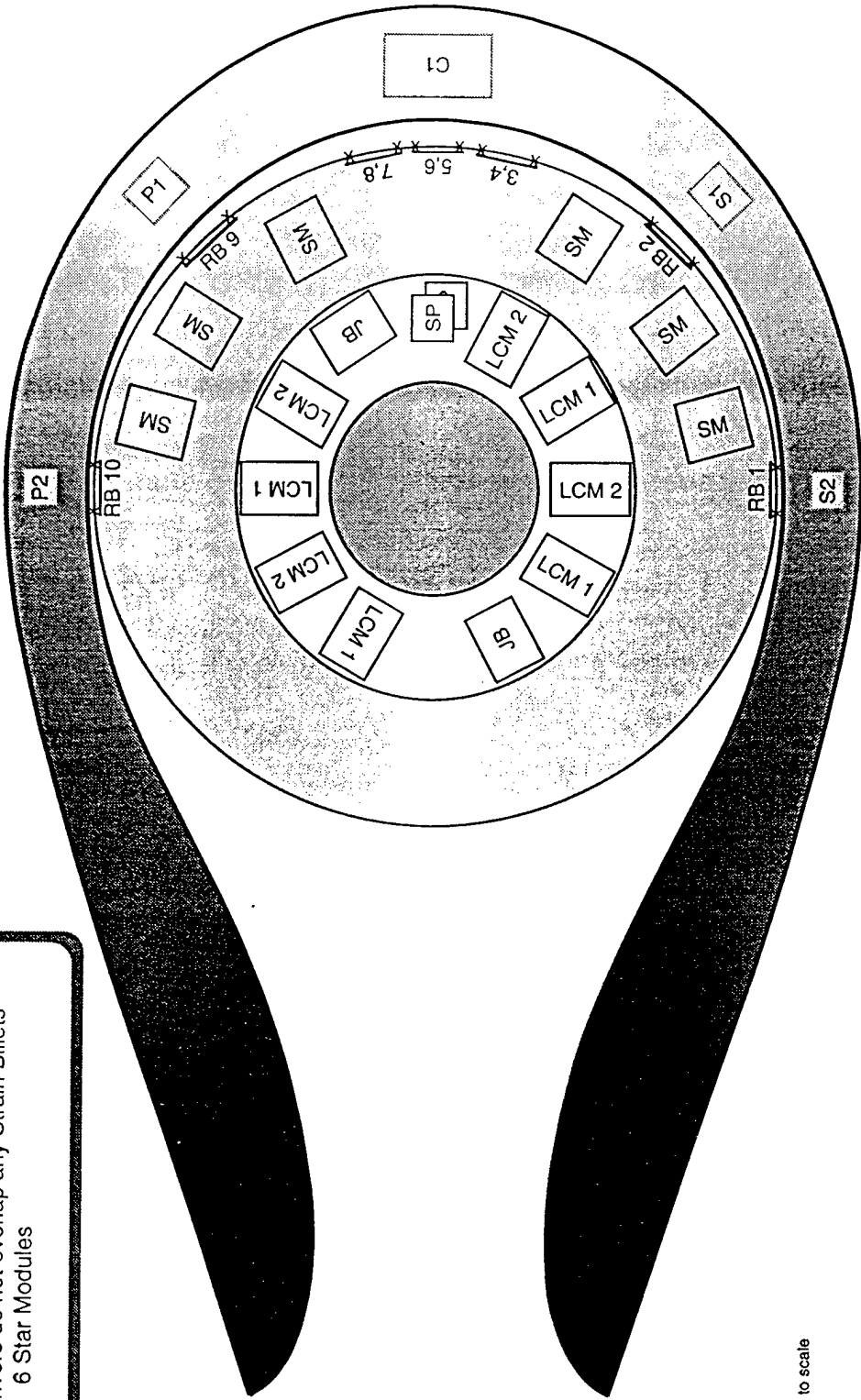

Not to scale

Figure 8: Banjo Layout of Modules, Receiver Arrays, and Dome Hydrophone Areas.



Figure 9: Displacement Sensor Hydrophone Array mounted on inner Sonar Dome surface.



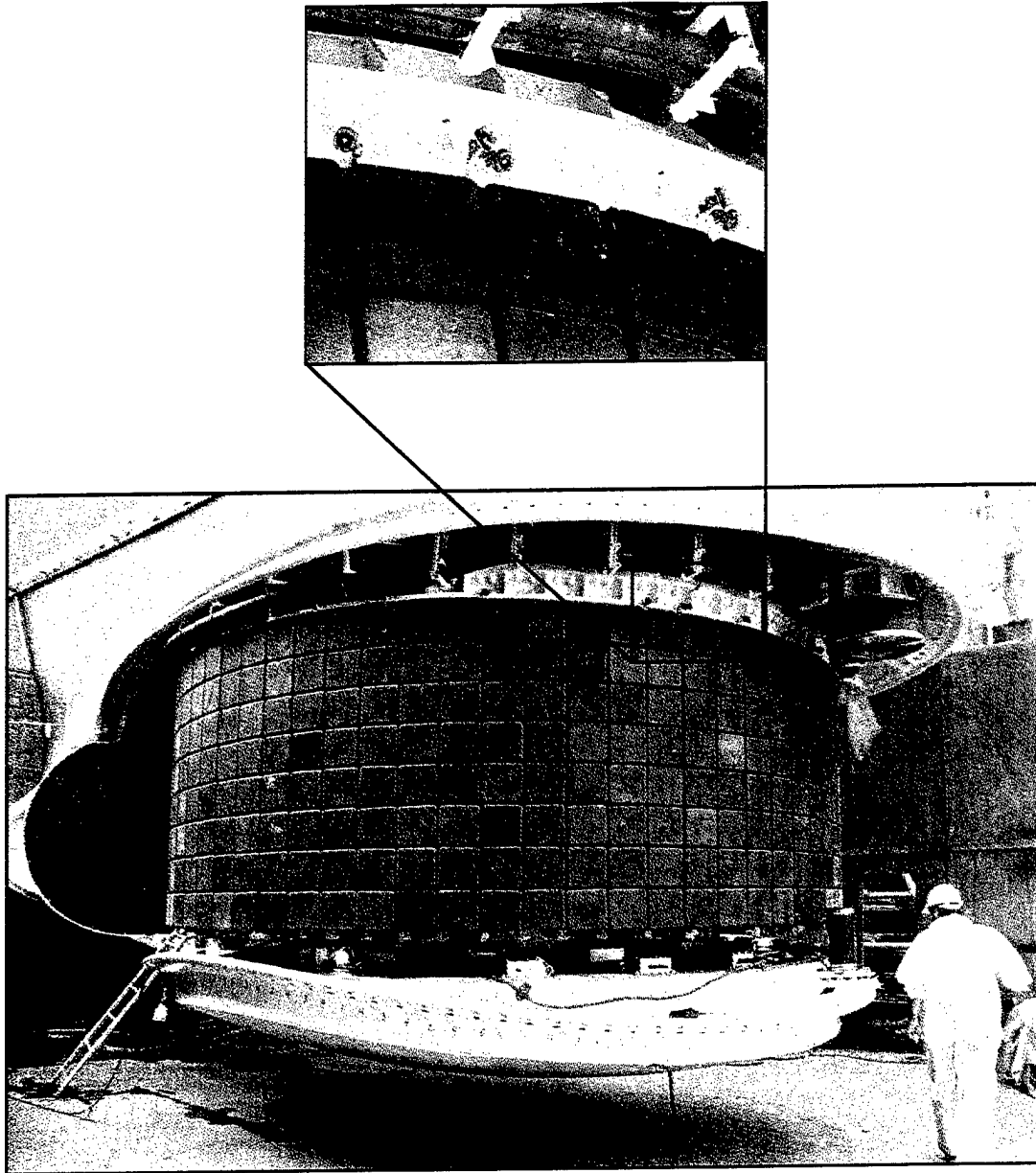

Figure 10: USS Radford Sonar Array with dome removed.

Note: Equipment Modules are visible below the Sonar Array. Expanded view shows Receiver Hydrophone Mountings directly above Sonar Array.

placed in rectangular grids, but here the array grid appears slightly distorted. This slight visual curving of the array grid (an effect of the projective distortion) makes this graphical technique useful for displaying, in a compact format, the deflections over the entire sonar dome. Hence this format is used below in the deflection contour plots.

## B. Measurement Plan

The electronic measurement system consisted of two computers installed on the ship and running in parallel. **Figure 11** shows a schematic of this overall computer system. One computer was dedicated to recording environmental data and compiling a continuous ship's log of each sea voyage. The second computer ran the main data acquisition program for obtaining strain and deflection measurements. It was also used to measure sound speed (for path-length calibration) and was the overall system controller and data archiver. When not engaged in data collection, this system was also used to process data at sea.

The data collection process starts with a preliminary test mode whereby each hydrophone location is tested for signal reception and stability. The results are used to identify the best group of hydrophones to use with each projector, and hence to produce a set of optimal scan patterns. These patterns were then used in the main program. This program sequences through projector locations contained in the selected pattern at a rate of 150 locations per second. This is repeated 100 or 200 times per data set, depending on the length of the data record desired.

The elapsed time of each data run varies depending on the size of the scan pattern and the number of times the scan pattern is addressed. For the biggest data records, data collection takes approximately 3.3 minutes to cycle through the largest scan pattern (consisting of the entire array of functional projectors and load cells). The software data string buffers, holding the time-of-flight data, are then flushed and the resident data converted to numeric format. This conversion process takes approximately 4 minutes. The formatted data is then written onto the magneto-optical disk taking approximately another 4.6 minutes. Thus each of these data runs requires approximately 12 minutes to complete before commencement of the next data run.

The at-sea measurement plan consisted of two modes of operation. In Mode 1 we were to collect data on a "not-to-interfere" basis while the ship was

Figure 11: Sonar Dome Deflection Measurement System Block Diagram

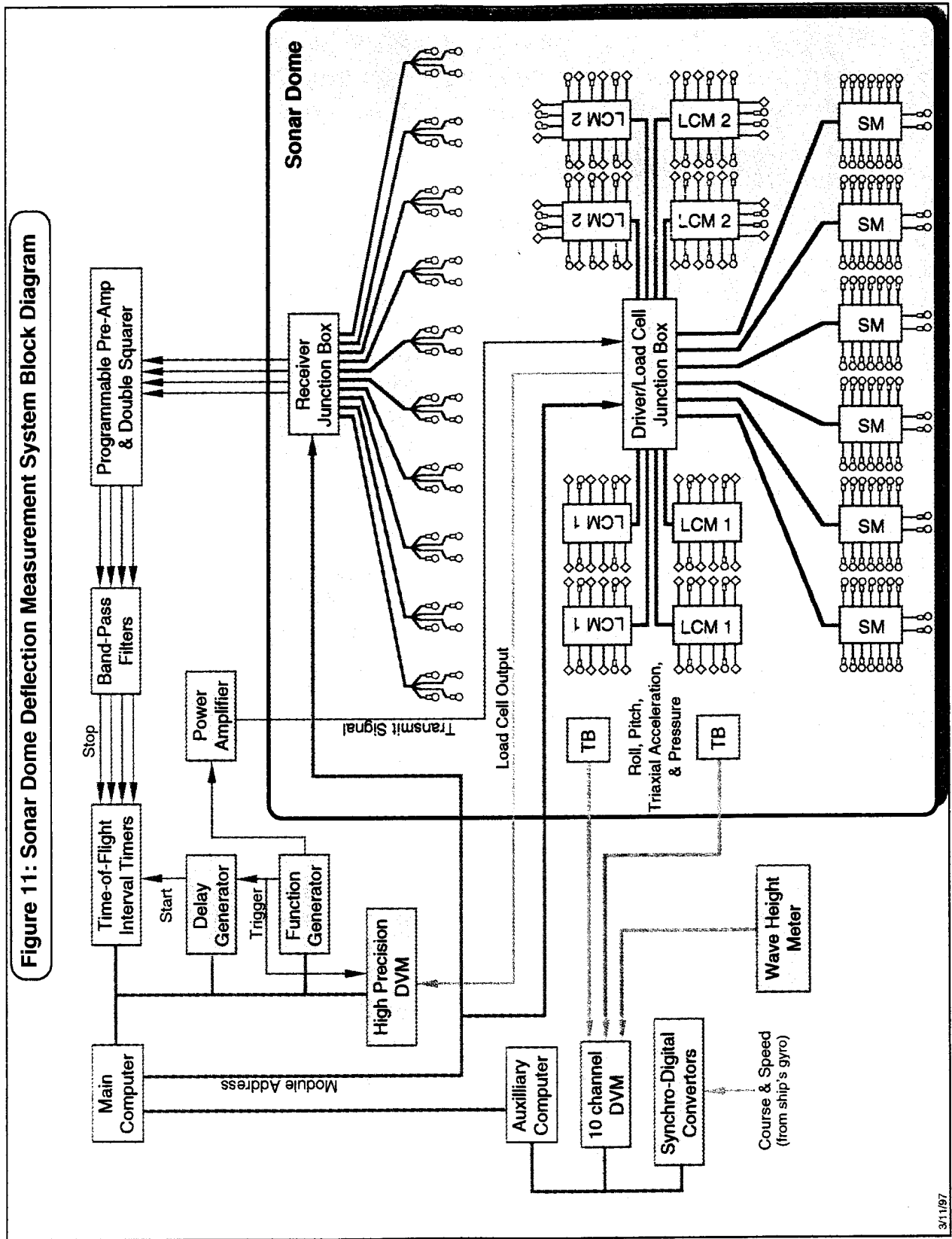

performing other tasks. Hence, ship speed, course and wave height would be monitored while deflection and other environmental data were continuously collected. In Mode 2 some ship time was to be made available to our program for special maneuver and calibration data runs. We requested that the ship travel into the waves at constant speed and course at the following speeds: 5, 10, 15, 20, 25, and 30 knots. We requested that these runs be repeated at each different sea state encountered during the various underway periods. Additionally we requested runs at each speed also be performed while the ships was performing hard turns both to port and to starboard.

### C. At Sea Measurements and Events

The first sea voyage for data collection was during the USS RADFORD shakedown cruise after the 6 month drydock overhaul. This underway period occurred from Oct 30 to Nov 6, 1997. Twelve (12) pierside calibration data runs were performed prior to Oct 30. During this first cruise 122 data sets were collected over a wide range of ship speeds from 0 to 31 knots, and at sea states 1 through 4.

Various problems, beyond our control, occurred during this sea trial. We experienced continuous difficulties with the ship's "Synchro" system. This shipboard system transmits course and speed signals to vital parts of the ship (such as combat systems). Since the signal from this system was largely unusable during this period, for many of our data sets we could only manually log these parameters before and after the data run, and were thus unable to acquire dynamic data for these variables. The ship was only able to perform 6 calibrated data runs for us on the night of Nov 4, 1997 due to operational constraints and the priority of other experimental programs on board (the new composite Mast and associated radar experiments).

The second sea voyage occurred from Dec 2 to Dec 4, 1997. The ship's synchro system was, once again, functioning sporadically and we had great difficulty taking data with reliable ship's course and speed. A civilian expert on the synchro system was on board for this cruise and found that the main ship synchro switchboard (in the DP center below CIC) had been wired incorrectly. He stayed on board from Dec 4 to Dec 9 to rewire the switchboard and fix the synchro system. We did manage to obtain 24 additional data sets.

The third sea voyage was conducted from Dec 9 to Dec 12, 1997. The synchro system was working better, but we still experienced some problems in obtaining reliable data runs (i.e. we still had to occasionally abort runs and start over when the synchro signals failed to lock properly). Also, the ship experienced shaft problems on one screw, which limited speed to 22 knots. In addition, other projects maintained a higher priority and therefore the USS RADFORD was only able to perform a limited number of additional calibration runs. The few calibration runs that were performed were all directly into the waves. No calibration runs were ever performed during high-speed turns as originally requested. We did succeed in obtaining 74 new data runs over sea states 1 through 4, but only at or below 22 knots.

On Jan 11, 1998 we returned to the USS RADFORD to begin the removal of our equipment. Before beginning the dismantling process we performed two more pierside calibration data runs. These were designed to obtain additional information on dome sag as well as a final check on system performance.

---

### **III. DATA COLLECTED**

---

#### **A. Data Set Summary**

**Appendix 2** contains a list of the 234 data sets that were collected onboard the USS RADFORD. The list is sorted both by data run file name/date and by ship speed. An explanation of the file naming system, additional information about the file structure format, and related information contained in the other columns of the table is described in the appendix.

#### **B. Scan Patterns**

**Appendix 4** contains the four scan patterns used in collecting the majority of the data during all of the at-sea cruises. These four scan patterns each have 150 elements. All of the data sets whose file names begin with an "R" used one of these four scan patterns. There were also many scan patterns used that just contained a subset of these 150 elements, where these smaller sets could be fully interrogated at a faster rate to follow the dynamics of local regions of the dome at higher frequencies.

The initial scan pattern, SCAN150, was developed after the installation of the transducers and used during the initial pierside calibrations. We realized that some modification to these scan patterns would likely be needed to accommodate changing environmental conditions during the at-sea data runs. For example, as the dome deflects it will redirect the main lobe of the radiated acoustic energy from each projector and this can cause a change in the received signal level, particularly if the receiver is already near the edge of the main lobe. Since the magnitude of these effects could not be predicted, allowance had to be included for at-sea adjustment.

One type of adjustment involved changes to the scan pattern. A few of the hydrophones failed to perform properly once at sea. These were simply replaced in the scan pattern by neighboring elements. **Appendix 4** shows the initial pattern and the three modifications that we made at-sea. Initial changes in the scan pattern are shown in red.

The second type of adjustment involves resetting the preamplifier gains on the receivers to compensate for signal changes. The system included computer-controlled amplifiers that could be programmed during data acquisition to accommodate signal level changes. These were varied when necessary to provide constant signal amplitude to the trigger threshold of the timers. Often (and particularly during the last sea cruise) we found that lower amplification levels were required at-sea than were needed previously.

### C. Data Processing

The environmental parameters were direct electrical measurements. These only required simple mathematical processing to convert from volts to the appropriate physical variable.

The deflection data collected at-sea had three significant potential sources of error, inherent with the use of the acoustic time-of-flight measurement process. These three contributors are: acoustic multi-paths, trigger noise, and trigger-level variation. These are described below.

(1) Acoustic multi-path refers to the system triggering on an acoustic signal that arrived at the receiver via a non-direct path. This can occur when the direct-path signal is blocked by an obstruction. (There were two WQC-2 communication transducers in the bow region that the projectors

were designed around but due to the motion of the dome occasionally some of the signals were obstructed by these transducers). It can also occur when the direct signal is reduced in amplitude below the required trigger level. In such cases the system may trigger on the next available signal, which will typically involve a reflected path. In some cases errors of this type are obvious (i.e. the transducer appears to be moving in the wrong direction) but in other cases it is difficult to discern.

(2) Spurious environmental noise can result in a signal of sufficient amplitude to trigger the system timers. In a shipboard environment, both acoustic and electrical noise sources are common. Their influence on system performance is greatly reduced by proper system design, including bandwidth restrictions and very small acceptance periods. Even so, an occasional interference is expected. Because of their random nature, these sources are usually relatively easy to detect and remove in the post-processing.

(3) Trigger level variations are typically not detrimental unless they exceed a threshold. The received signal consists of a few cycles of sound, each with different amplitude. The amplifier gain is selected such that the timers trigger on an early cycle that has large amplitude. Small variation in the overall signal amplitude (for example, due to environmental changes) will slide the trigger point up or down on this cycle, but this will have very little influence on the measured time-of-flight. However if the amplitude decreases sufficiently, the cycle of interest will not have sufficient amplitude to trigger the timers, and the timer will instead be triggered by the following cycle. Alternately, if the amplitude had increased sufficiently, the trigger point would shift to the earlier arriving cycle. Either case introduces a sudden systematic error in the measured time-of-flight corresponding to the period of one acoustic cycle.

Thus, the first step in the data processing is to groom the time-of-flight records of any outliers caused by the above potential error sources. This process is accelerated through the use of a semi-automated grooming program. However due to the random and unpredictable nature of some of the outliers, the grooming process could not be fully automated and still required significant manual intervention.

Once the data has been groomed (cleaned of outliers), a conversion program converted the set of time-of-flight values into x, y, z coordinates. This involved use of the measured sound speed and the known reference

locations of the receiver hydrophones. The resulting files were then transferred to an AVS format<sup>3</sup> for 3D animation, as well as into spreadsheet format for mechanical analysis. Although these spreadsheets are exceptionally large, the graphical displays they generated were extremely useful. Principal among these were the displays of the dome centerline region, the -4 foot waterline, and contour plots of the average (static) deflections over the measured dome surface.

#### D. Environmental Data Display

As with all extremely large and interconnected multi-parameter data sets, visualization tools will play an important role in the data analysis. This data set includes 234 runs each keyed to as many as 400 interrelated parameters (3D displacements, strains, and environmental). Without the development of custom software and standardized display formats, the data set would have only very limited use and its interpretation would potentially be subject to serious errors. The purpose of the visualization and graphical analysis software developed as part of this study is to avoid incorrect interpretations and reveal trends and relationships that might otherwise be obscured.

A standardized compact graphical format was developed to display the environmental data. It includes the following: ship speed and course, wave height, pressure, ship roll and pitch, and the three axes of acceleration (x, y, and z) for each data set. A software pipeline was developed to produce a (one-page) environmental information sheet for each data set. This sheet can be extended to include additional measured parameters (i.e. dome deflection at select locations), when deemed helpful in the analysis. While originally intended as a screening tool for selecting interesting data sets for subsequent analysis, these compact environmental data sheets have proven so useful to our analysis that we have included most of them in **Appendix 5**.

A large number of these environmental data sheets are incomplete due to the failure of the ship synchro system. This failure manifests in several ways. Either in the complete absence of data for ship speed and/or course, or in the failure to establish phase stability. In the first case, the affected

---

<sup>3</sup> Application Visualization System software program from Advanced Visual Systems, Inc.



environmental data sheet plot will just be constant (i.e. a fixed value input before the data run with no dynamic data), or blank and marked as "Unavailable", such as in data runs C138A and C3a. In the second case, the plot will show either a continuous phase increase (appearing as a "sawtooth" curve due to the phase rotation from 360 back to 0 degrees, as in RL13b), or a temporary loss of phase stability (as in data runs R6a or CM17a).

The environmental data sheets with complete dynamic information naturally fall into two groups. A very small group had significant ship speed changes during the run, but the vast majority of runs occurred only at a relatively constant speed. When a significant speed change occurs during the run, the effects of the speed change are so large that all other aspects of the data are difficult to detect.

Of particular interest is the environmental data sheet for RLm28a. During this data run the ship accelerated from 16.5 knots to 28 knots in approximately 40 seconds. The pressure inside the dome goes up; the pitch of the ship initially goes down but then stabilizes; the roll parameter shows the ship shuddering and then slowly settling down. In the two dynamic dome deflection graphs, it is interesting that the usual dome dynamic oscillations are washed out by the large static dome deflection changes. This should be compared with RL28a (shown in Figure 7) where a very small increase in speed occurs.

### **E. Dome Centerline and -4 Foot Waterline<sup>4</sup> Displays**

The motion of the front portion of the sonar dome is of particular interest for understanding sonar dome behavior under at-sea conditions. For many purposes, this behavior can be summarized by studying the motion along the bow vertical and horizontal centerlines. These two lines are more precisely defined as the dome vertical bow centerline (often referred to as just the "Centerline"), and the (horizontal) -4 foot waterline.

The instantaneous displacements measured at any given ship speed are separated into static and dynamic components. The overall static

---

<sup>4</sup> The origin of the coordinate system was at the top center of the ship sonar array with the Z axis positive in the upward direction. Thus, the top of the sonar dome is at the Z=0 plane with dome Z values increasingly negative as you proceed down the dome surface. The -4 foot Z coordinate value produces a horizontal slice through the sonar dome at approximately the middle of the dome.

deformation at a given ship speed is an average over the ship run, while dynamic component is the instantaneous deviation from this static value. Static deformations are best displayed in 2-D graphs, while the dynamic behavior is best studied using 3D animations.

**Appendix 6** includes a series of graphs (sorted by average ship speed) showing the measured static deformations for these two special dome lines. For each data run selected, we display static deformations at both the centerline, and the -4 foot waterline. The -4 foot waterline curve is perpendicular to the centerline curve and crosses through the centerline curve at a z coordinate value of -48 inches (as should be expected). Each plot also includes the reference curve for the corresponding data at zero ship speed (i.e. the measured pierside dome position).

An examination of the highest speed graph (R30B) reveals the typical static dome behavior. Above the -70 inch line (-5 foot 10 inches) the dome is forced inward and downwards towards the ship sonar array. Below the -70 inch line the dome is forced outwards and downwards away from the ship sonar array. The -4 foot waterline curve shows that the maximum deflection occurs at the very center of the dome (at  $Y=0$ ), and at high speeds (above 25 knots) a dimple forms along the upper centerline. A more complete picture of this behavior can be seen in the full dome contour plots below.

## F. 2D Contour Plots of the Dome Displacement

**Appendix 7** contains 35 of the 2D contour plots arranged by ship speed. Each page shows two sets of graphs for the same data set, each with an interpolated 2-color display of a particular component of the average dome deflection and with an associated contour plot. These graphs use projection mapping of the sonar dome to show the entire measured area of the dome in one plot (as discussed previously). The first two plots show the average horizontal component of dome displacement. The surface normal vector at the -4 foot waterline for each radial frame was used to form a scalar dot product with the average vector (i.e. 3-dimensional) displacement at each hydrophone location on that radial frame. This gave the average horizontal components of the displacement for all of the hydrophone locations. This data was then used to produce a continuous 2-Dimensional interpolated surface of the average displacements over the entire sonar dome. For the second set of two graphs, the average value of the vertical displacement (i.e. the Z component of the displacement from the pierside position) at

each hydrophone location is used to produce a continuous interpolated surface.

The 2-color scheme was selected to distinguish inward vs. outward dome deflection (in the horizontal plane) and up or downward displacement (in the vertical plane). Magenta represents inward displacements on the horizontal graphs and downward displacements on the vertical graphs. Cyan similarly shows the outward and upward displacements respectively. As the ship speed increases, the numerical values used on the color scaling changes. A constant scaling of +1 to -1 inch is used from 0 to 22 knots on both the horizontal and vertical contours for uniformity. But, due to the rapid increase in dome deflection as ship speed increases above 25 knots, the scaling continuously changes up to the 31 knot run of R30B where scaling of +1 to -6 was needed for the horizontal plot, and +1 to -3.5 for the vertical.

The most significant feature on these contour plots is the inward depression that occurs in the upper centerline region. Due to the relative incompressibility of the water filled sonar dome interior, this large inward movement is compensated by the outward bulging of the bottom of the centerline region and also the outward movement of the sides of the dome.

As seen from the lower two plots on each page, the vertical displacement is almost uniformly downwards. There is a slight lifting upwards on some of the sides of the dome. The most significant feature of the vertical displacement is the pronounced downward displacement at the lower centerline.

These contour plots display the overall average (or static) deformations of the dome. Since the ship speed and course usually varied during the data run, even on the so-called "calibrated" runs, each contour plot is a unique average over varying conditions.

No data could be collected on dome behavior during high-speed sharp turns. Unfortunately the Commanding Officer would not permit runs involving hard turns. Hence all of the contour plots are for essentially forward ship motions. From an examination of the environmental data sheets (Appendix 5) it can be seen that there are a few data runs where the ship was turning, however these turns were so slow and gradual that no significant differences can be seen in dome behavior.

## G. 3D Animation Display

Using the AVS animation and display program we have produced MPEG movies of sonar dome displacements. The animation displays a 3D view of the sonar dome showing its absolute displacement during the period of the run. Since these absolute displacements are small compared to the size of the dome, a color map is displayed on the surface of the dome scaled to represent a particular component of the displacement. For each data run there are three possible animation sequences showing (separately) the displacements in the x, y, or z directions. Ten animation sequences produced for this report are available in the attached CD-ROM and an additional CD containing an MPEG display program is available upon request.

The 3D animation also includes two animated 2D slices through the dome. The centerline slice is located to the right of the 3D display, and the -4 foot waterline slice is positioned below the 3D display.

One timeframe from the first animation sequence is shown at the beginning of the executive summary. The frame shown in this example represents the vertical component (z-direction) for the R30B data record.

---

## IV. RESULTS AND DISCUSSION

---

As expected, the present data set shows the same general type of overall dome behavior as measured previously on other sonar domes<sup>5</sup>. However the data set described in this report contains two important improvements over that previously obtained for other domes. First, it is far more extensive, including details of dome behavior revealed here for the first time. Second, it includes a much more comprehensive set of auxiliary sensors. These allow a more accurate and detailed correlation of the affects of the environmental parameters on the sonar dome displacements.

An illustration of the degree of improvement that has been achieved can be obtained by comparing the frame from the present animation and the

---

<sup>5</sup> see NRL memos to NAVSEA on measurements taken on the USS Yorktown in 1989.

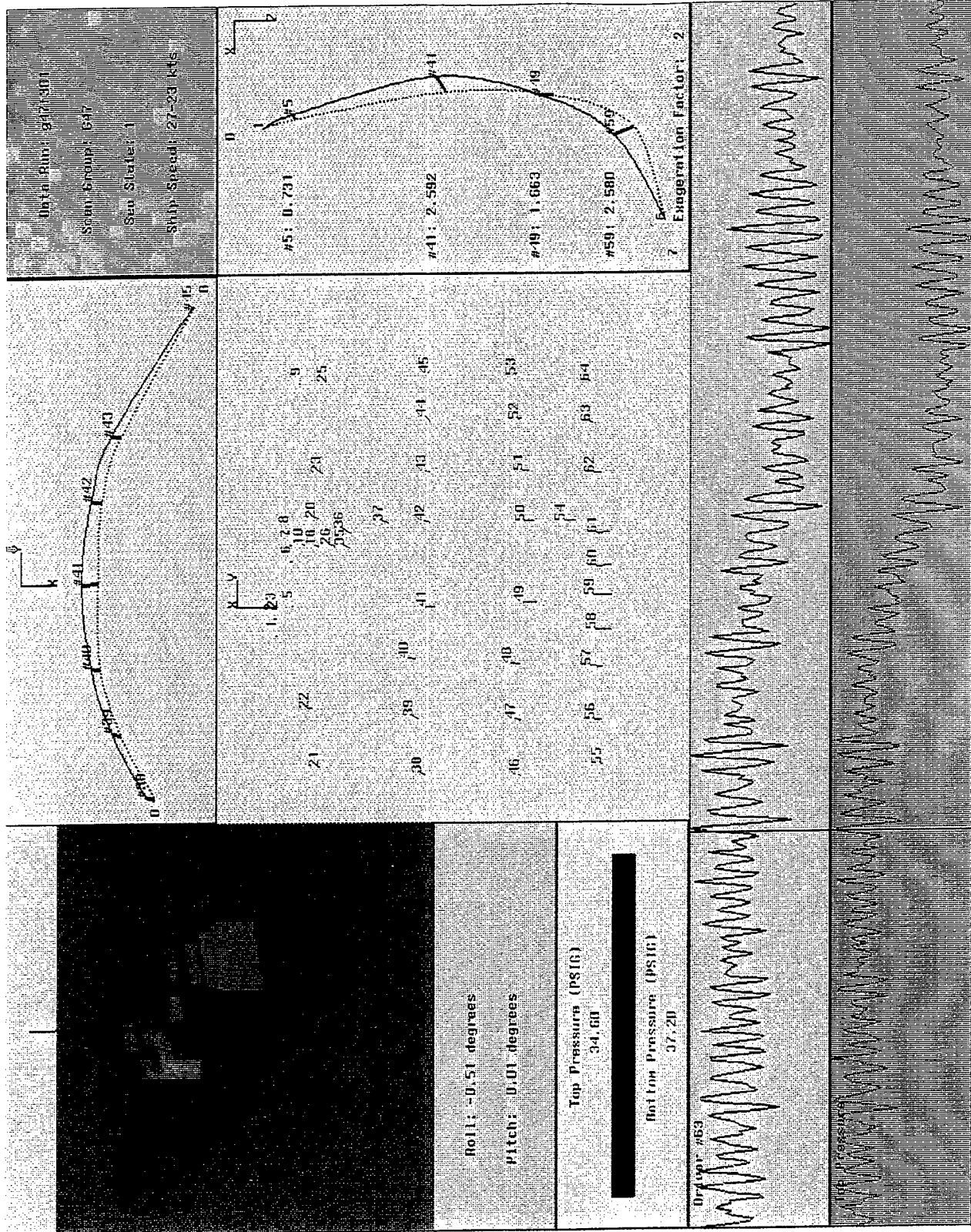

Figure 12: Sonar Dome Deflection Animation from USS Yorktown data, Jul-Aug, 1989.

display of environmental data (**Figure 7**) with the frame from the previous animation for the USS Yorktown sonar dome shown in **Figure 12**. While both show the same general deformation (i.e. the upper part of the dome bulges in and down, the lower part bulges out and down, and the sides of the dome bulge out and slightly upwards), the improvement in surface coverage, resolution, and in the range of environment parameters is dramatic.

As an aid in visualizing the data presented below, **Figure 13** shows an exterior photograph of the bow region of a Navy destroyer with the coordinate system used in these measurements superimposed. The center of the coordinate system is at the overhead center of the ship's sonar array.

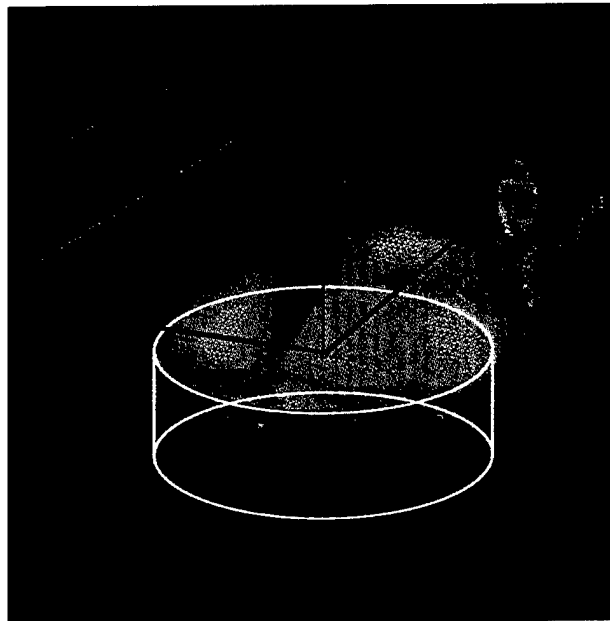

Figure 13, USS Radford Monolithic SDRW Coordinate System

The principal observations of dome behavior derived from this data set are the following.

The centerline deformation was consistent with previous measurements, but larger in amplitude. The maximum deformation observed (i.e. the magnitude of the vector difference between pierside location and the measured location during the data run) is found to be 5.27 inches at 31 knots.

This increased deflection along the centerline of this new monolithic SDRW design is not necessarily detrimental. Previous domes were

manufactured in two pieces and spliced together, resulting in a center section that is double thickness. This stiffened center section resisted deformation, but consequently its design increased strain in the region immediately adjacent to this vertical splice. The monolithic dome was specifically designed to reduce this strain, and some increase in deflection was anticipated.

The deformation behavior of the centerline for the highest speed run (R30B at 31 knots) is shown in **Figure 1**. This shows that due to the force of the seaway, the upper part of the dome is displaced inwards (towards the sonar array), and the lower part bulges outwards. **Figure 1** also shows that the entire front section of the sonar dome was displaced downwards, with the largest downward displacement in the lower region.

**Figure 2** shows the -4 foot waterline deformation for the same data run at 31 knots. A depression is observed (particularly at high speed) for approximately 20 inches around the upper centerline. This feature can also be clearly seen in the contour plot of **Figure 3**. The inward deformation of the upper front part of the dome (shown in magenta) is compensated by the outward deformation of the lower front and the slight outward deformation of the sides of the dome (shown in cyan). There is an overall downward deformation of the entire dome (seen in the second plot in **Figure 3**), with the front of the dome experiencing the largest shift downwards. This shows that the downward displacement noted above in item (2) for the front part of the dome applies globally to the entire sonar dome.

The magnitude of dome deflection is primarily determined by the force of the seaway. This can be seen in **Figure 4**, where data from 100 at-sea data sets are plotted as a function of ship speed and sea state. The exponential nature of the deformation vs. ship speed is clearly visible when this data is replotted on Log/linear scale, as in **Figure 5**. A numerical fit to **Figure 5** is:

$$D = 0.6 * \text{Exp}(0.14 * S)$$

where D is the magnitude of the dome deflection in inches at a ship speed of S (in knots).

**Figure 5** (and the numerical relationship above) shows that the magnitude of the deformation doubles approximately every 5 knots. The implications of this relationship imply that at high ship speeds the structural strain inside

the sonar dome also increases exponentially. **Figures 4 and 5** also show that, within the limited range of sea states measured, the deflection magnitude did not depend significantly on sea state. This was a somewhat surprising result, as it was originally thought that higher sea states would result in added ship motions, which would produce additional dome oscillations. However, the lack of any real difference between the data for sea states 2 and 3 could be due to the limited range of sea states measured. Although some measurements were made at sea states 1 and 4, there were not enough to be statistically relevant in the plots of the above figures. It is unfortunate that the ship avoided heavier seas during these tests.

Correlating internal dome pressure to the other measurements is complicated by the type of pressure release system utilized on the ship. This system will apparently allow automatic pressure release if it detects sustained over-pressure conditions. When this occurs it is not reported or recorded. We did not observe this during any of our data runs, however our record of internal pressure from all of the data runs (from Oct. through Dec., 1997) indicates that the pressure was probably reset several times during this interval.

During any one data run there is an increase in dome internal pressure as ship speed increases (nominally 0.25 PSI per knot). This is seen in the data from the single data record R1m28a during which the ship speed changed from 16.5 to 28 knots. **Figure 6** shows this record as well as the average dome pressure for several other data runs.

In examining the environmental parameters for correlation to dome deformation, the greatest effect (besides ship speed) appears to be caused by the vertical acceleration of the ship. The vertical motion of the ship causes oscillatory dome deformations, which also cause internal dome pressure fluctuations. **Figure 7** shows a sample set (data run RL28a) of some of the environmental parameters measured during each data run.

We recorded no direct evidence for ship slamming and assume that none of the data sets recorded this type of ship event. Runs to include ship slamming were planned and requested, but not executed by the ship. This data would probably have revealed new aspects of dome behavior.

Data run RL28a was selected for **Figure 7** because it displays two different features of the environmental data. These two features are: (a)



effects caused by significant speed changes, and (b) dynamic effects caused by other ship motions, such as roll, pitch, etc.

When the ship speed changes appreciably during a data run, usually the change in dome deformation (and the other significant environmental parameters) is so large that the dynamic fluctuations are obscured. In RL28a the ship only increased speed by approximately 0.5 knot after the first 60 seconds of the data run. This speed change produces a noticeable increase in the horizontal deflection curve and an increased downward (i.e. more negative) vertical deflection. Also noticeable is a slight increase, by approximately 0.25 PSI, in the average pressure. Thus, this data run is unique, in that the speed change is just large enough to demonstrate its influence on the other parameters, but without obscuring the dynamic aspects of the data which are independent of ship speed.

The dynamic effects are still clearly discernible in **Figure 7** and show the correlation between vertical (i.e. Z-axis) acceleration, pressure, and the horizontal and vertical deflections. This is most apparent in the time interval between 90 and 120 seconds where the largest dynamic oscillations occur. Notice that there is no visible correlation between the above parameters and the dynamic parts of the wave height, ship speed, and ship course data.

---

## V. CONCLUSIONS AND FUTURE PLANS

---

As a result of the measurements of the USS RADFORD sonar dome we can make the following major conclusions about the monolithic sonar dome behavior at sea:

- (1) The centerline dome deformation is large at high speed, and doubles in magnitude with each 5 knot increase in ship speed. At the highest ship speeds this may be capable of generating significant (and perhaps cumulatively damaging) strains in certain dome regions.
- (2) At high speeds the shape of the dome deformation in the centerline region should generate a significant increase in flow noise.
- (3) The general motion of the centerline area of the dome is divided into two regions at approximately the -70 inch waterline. The upper region

deflects inwards and down, and the lower region bulges outwards and down.

(4) The most significant correlation between ship motions and sonar dome oscillation is produced by the vertical acceleration of the ship.

This report highlights the obvious behaviors contained in this enormous and exceptionally rich database. We recommend a continuation of the analysis and correlation. In particular, we recommend that a map of the strain levels in the dome and near the mounting edges be derived or inferred from this set of deflection data.

---

## VI. ACKNOWLEDGMENTS

---

The authors would like to acknowledge the assistance of many people in the design, production, and installation of the Sonar Dome Deflection Measurement System. In particular we would like to thank the following:

Stan Silverstein of NAVSEA PMS 411 for financial support and interface with naval higher commands;

Chester Poranski of NRL Code 6126 for overall project management;

Joe Chou of Geo-Centers, Inc. for mechanical design of the Wave Height Sensor mounting system and assistance in the design of the underwater multiplexing modules;

Jody Smallhorn of Geo-Centers, Inc. for overall project logistics; and assistance during the installation and removal procedures;

Ken Campbell of Geo-Centers, Inc. for assistance during the installation and removal procedures;

Howard Schrader of Geo-Centers, Inc. for mechanical design of the Wave Height Sensor mounting system and assistance in the design of the underwater multiplexing modules; and for management of the installation and removal procedures;

Jim Ruble and the MADCAT Survey crew from B. F. Goodrich;

and finally, the crew of the USS RADFORD.

---

## VII. APPENDICES

---

- (1) Table of Environmental Parameters
- (2) List of Data Sets
- (3) Hydrophone Position Displays
- (4) Evolution of the Scan Pattern
- (5) Environmental Data Sheets
- (6) Centerline and Waterline Plots
- (7) Contour Displacement Plots

## Appendix 1: Measured Environmental Parameters

Data Column	Sheet Letter	Format of Environmental Data File
1	A	Index number
2	B	Julian Date (1-365 days)
3	C	Hour
4	D	Minutes
5	E	Seconds
6	F	Relative Wave Height (RWH) <sup>1</sup>
7	G	Pressure Transducer #25: right meter, behind Baffle Plate <sup>2</sup>
8	H	Pressure Transducer #07: center meter, in Bottom Transducer Box (TB-B) <sup>3</sup>
9	I	Pressure Transducer #10: left meter, Top Transducer Box (TB-T) <sup>4</sup>
10	J	Pitch Inclinometer #2084: Bottom Transducer Box (TB-B)
11	K	Roll Inclinometer #2137: Bottom Transducer Box (TB-B)
12	L	Roll Inclinometer #2085: Top Transducer Box (TB-T)
13	M	Pitch Inclinometer #2138: Top Transducer Box (TB-T)
14	N	Ship Displacement (SD) <sup>5</sup>
15	O	X- Accelerometer #1531: Top Transducer Box (TB-T) <sup>6</sup>
16	P	Y- Accelerometer #1531: Top Transducer Box (TB-T)
17	Q	Z- Accelerometer #1531: Top Transducer Box (TB-T)
18	R	Temperature <sup>7</sup>
19	S	X- Accelerometer #1530: Bottom Transducer Box (TB-B) <sup>8</sup>
20	T	Y- Accelerometer #1530: Bottom Transducer Box (TB-B)
21	U	Z- Accelerometer #1530: Bottom Transducer Box (TB-B)
22	V	Ship Course Heading <sup>9</sup>
23	W	Ship Speed <sup>10</sup>

<sup>1</sup> Wave Height = RWH - SD

<sup>2</sup> was replaced with Significant Wave Height in data taken after Dec. 8, 1997.

<sup>3</sup> mounted on the floor of the banjo plate, inside sonar array.

<sup>4</sup> mounted on the overhead directly above the Bottom Transducer Box.

<sup>5</sup> from the Wave Height Measurement system.

<sup>6</sup> Triaxial accelerometer

<sup>7</sup> internal sonar dome water temperature

<sup>8</sup> second Triaxial accelerometer

<sup>9</sup> input from the USS RADFORD synchro system, tapped from the Ship's gyro.

<sup>10</sup> also from the Ship's gyro, this was in Angular Degrees of Speed (ADS) with (Speed in knots = ADS\*40/360).

## Appendix 2

### List of Data Files

Lists of the 234 Sonar Dome Deflection Data files collected at-sea aboard the USS RADFORD. For each file listed there exists separate files with the same name but with distinct suffixes for the strain data, and for the environmental data. Two copies of the original list are shown, sorted by group/date, and ship speed.

File names that begin with RAD or R refer to data runs where the full array of transducers (150) were scanned. Those that start with SIDE or S used only the 20 transducers on the opposite sides of the dome (port or starboard 90 degrees). Files that start with DIA or D used the 58 transducers on receiver arrays 2 and 9 (i.e. for hydrophones between radial frames 3.5 to 6), and those files that start with CEN or C contained only the 72 transducers near the centerline of the dome.

In the data set list sorted by ship speed, there are two different groups given as having zero speed. Besides the pierside calibration runs, there is also those data sets taken during the ship's synchro system failures. These are listed as of zero speed only because no dynamic ship speed was recorded. However, except for the data set names starting with "RAD", the numbers in the file names referred to the ship speed at the time the data run terminated. Notice that the ship speed listed by each data file name is the average speed over the entire data run (approximately 3.3 minutes). There are several runs where the ship was changing speeds during the run (as in #104, CAL20 which was supposed to be a pre-arranged fixed speed run) and where the listed speed does not correspond to the number in the file name.

The directory the file was stored in is reported in column 2 (this was important due to the unintentional duplication of a few file names), the number of times the scan pattern was addressed during the data run is listed in column 3. This number directly controlled the actual length of time the data run took to complete. Column four shows the name of the actual scan pattern used in the data collection. These patterns were modified twice during the sea cruise as a few individual transducers failed and had to be replaced in the scan pattern by duplicating existing transducers that performed well (a chart showing the evolution of the scan patterns is shown in Appendix 4). The 5th and 6th columns of the data set list shows the date and times that the data was collected. The 7th column shows the average ship speed during the data run, and the 8th column shows the maximum wave height that was measured during the data collection.

Data Sets sorted by Ship Speed

Ave. Speed (knots)		File Name	Directory	Data Length	Scan Pattern	Date	Time	Max Wave Ht. (ft)
0.00	15	RAD31B	R1A/DATA	100	SCAN150	31-Oct-97	09:11	8.64
0.00	16	RAD31C	R1A/DATA	100	SCAN150	31-Oct-97	09:18	4.39
0.00	17	RAD31D	R1A/DATA	200	SCAN150	31-Oct-97	09:40	10.61
0.00	33	R18d	R1A/DATA	200	SCAN150	31-Oct-97	20:53	17.98
0.00	34	R14a	R1A/DATA	200	SCAN150	31-Oct-97	21:04	22.81
0.00	56	R21A	R1A/DATA2	200	SCAN150B	1-Nov-97	13:36	23.25
0.00	58	RM15A	R1A/DATA2	200	SCAN150B	1-Nov-97	14:10	34.39
0.00	59	R0A	R1A/DATA2	200	SCAN150B	1-Nov-97	14:20	17.43
0.00	67	OR7a	R1A/DATA2	200	SCAN150	1-Nov-97	22:05	18.32
0.00	69	R9B	R1A/DATA2	200	SCAN150B	2-Nov-97	09:31	29.42
0.00	76	C3a	R1A/DATA2	200	SCAN72B	2-Nov-97	11:52	31.38
0.00	119	MAC0a	R1B/DATA	200	S150C	5-Nov-97	15:26	2.29
0.00	120	MAC0b	R1B/DATA	200	SCAN150	5-Nov-97	15:36	2.00
0.00	121	MAC0c	R1B/DATA	200	SCAN150B	5-Nov-97	15:46	1.74
0.00	122	MAC0d	R1B/DATA	200	S150C	5-Nov-97	15:56	1.49
0.00	123	P0a	R2A/DATA	200	S150C	1-Dec-97	13:58	5.43
0.00	124	P0b	R2A/DATA	200	S150D	2-Dec-97	09:38	2.33
0.00	184	Rn00a	R3A/DATA2	200	S150E	10-Dec-97	14:30	5.42
0.00	221	Rz00a	R3A/DATA2	200	S150E	12-Dec-97	13:23	7.98
0.00	222	Rz00b	R3A/DATA2	200	S150E	12-Dec-97	13:33	2.58
0.00	223	PCA	R3B/DATA	100	SCAN150	29-Oct-97	11:55	3.97
0.00	224	PC3	R3B/DATA	100	SCAN150	9-Oct-97	15:14	0.12
0.00	225	PC4	R3B/DATA	100	SCAN150	9-Oct-97	16:15	0.28
0.00	226	PC5	R3B/DATA	100	SCAN150	20-Oct-97	17:24	1.81
0.00	227	PC6	R3B/DATA	100	SCAN150	20-Oct-97	18:34	2.29
0.00	228	PC7	R3B/DATA	100	SCAN150	22-Oct-97	09:45	3.82
0.00	229	PSIDea	R3B/DATA	200	S150E	11-Jan-98	13:51	9.17
0.00	230	PSIDeb	R3B/DATA	200	S150E	11-Jan-98	14:00	1.11
0.00	231	PC1	R0	10	SCAN150	9-Oct-97	09:41	1.47
0.00	232	PC2	R0	10	SCAN150	9-Oct-97	09:57	0.04
0.00	233	PS110_1	R0	100	SCAN20_1	22-Oct-97	09:49	0.53
0.00	234	PS56_1	R0	100	SCAN20_5	22-Oct-97	09:52	0.62
1.47	199	Rp07a	R3A/DATA2	200	S150E	10-Dec-97	22:51	8.89
1.62	135	RF02a	R2A/DATA	200	S150E	3-Dec-97	10:44	11.38
2.03	136	RF02b	R2A/DATA	200	S150E	3-Dec-97	12:02	9.18
2.63	155	RL03a	R3A/DATA	200	S150E	9-Dec-97	10:54	3.53
3.72	196	Rp04a	R3A/DATA2	200	S150E	10-Dec-97	22:02	7.62
3.90	80	D4a	R1A/DATA2	200	SCAN58B	2-Nov-97	16:57	12.65
3.97	148	RH4a	R2A/DATA2	200	S150E	3-Dec-97	20:22	6.35
4.00	1	RAD30A	R1A/DATA	100	SCAN150	30-Oct-97	08:41	1.65
4.05	213	Ri05a	R3A/DATA2	200	S150E	11-Dec-97	22:34	11.85
4.20	108	SM4a	R1B/DATA	200	S20C	5-Nov-97	09:43	7.00
4.28	180	Rn04a	R3A/DATA	200	S150E	10-Dec-97	07:42	3.23
4.35	145	rZ5a	R2A/DATA	100	S150E	3-Dec-97	18:04	5.05
4.40	109	CM5a	R1B/DATA	200	S72C	5-Nov-97	09:48	6.33
4.60	107	DM4a	R1B/DATA	200	S58C	5-Nov-97	09:39	8.75
4.70	6	RAD30C	R1A/DATA	100	SCAN150	30-Oct-97	14:39	2.05
4.80	79	C5a	R1A/DATA2	200	SCAN72B	2-Nov-97	16:52	16.68
4.80	98	CAL5a	R1B/DATA	200	S150C	4-Nov-97	23:20	10.25
4.90	5	CEN30A	R1A/DATA	100	SCAN72	30-Oct-97	14:33	1.83
4.90	81	S4a	R1A/DATA2	200	SCAN20B	2-Nov-97	17:01	7.11
5.00	2	RAD30B	R1A/DATA	200	SCAN150	30-Oct-97	10:00	5.71
5.00	3	SIDE30A	R1A/DATA	100	SCAN20_1+10	30-Oct-97	14:26	2.01
5.00	4	DIA30A	R1A/DATA	100	SCAN58	30-Oct-97	14:30	1.82
5.00	78	R5a	R1A/DATA2	200	SCAN150B	2-Nov-97	16:44	23.11
5.00	106	RM5a	R1B/DATA	200	S150C	5-Nov-97	09:19	10.61
5.23	189	Rp05a	R3A/DATA2	200	S150E	10-Dec-97	15:28	6.63
5.28	197	Rp04b	R3A/DATA2	200	S150E	10-Dec-97	22:26	7.88
5.45	203	Rq05a	R3A/DATA2	200	S150E	11-Dec-97	10:33	11.01
5.50	91	R6e	R1B/DATA	200	S150C	4-Nov-97	21:26	11.45
5.70	82	C6a	R1B/DATA	200	S72C	3-Nov-97	23:34	9.73
5.70	88	R5a	R1B/DATA	200	S150C	4-Nov-97	20:19	12.19
5.88	176	RC05a	R3A/DATA	200	S150E	10-Dec-97	00:29	6.59
6.00	84	S6a	R1B/DATA	200	S20C	3-Nov-97	23:43	2.89
6.00	85	R6a	R1B/DATA	200	S150C	3-Nov-97	23:52	9.37
6.09	183	Rn10b	R3A/DATA2	200	S150E	10-Dec-97	14:19	5.39
6.10	89	R6c	R1B/DATA	200	S150C	4-Nov-97	20:53	13.44
6.27	181	Rn06a	R3A/DATA2	200	S150E	10-Dec-97	09:59	3.75
6.28	142	rg5b	R2A/DATA	100	S150E	3-Dec-97	14:58	13.43
6.32	182	Rn06b	R3A/DATA2	200	S150E	10-Dec-97	10:37	7.40
6.40	83	D6a	R1B/DATA	200	S58C	3-Nov-97	23:39	5.99
6.60	86	R6b	R1B/DATA	100	S150C	4-Nov-97	09:16	5.40

Data Sets sorted by Ship Speed

Ave. Speed (knots)		File Name	Directory	Data Length	Scan Pattern	Date	Time	Max Wave Ht. (ft)
6.60	188	Rp08a	R3A/DATA2	200	S150E	10-Dec-97	15:17	10.14
6.62	143	rg6a	R2A/DATA	100	S150E	3-Dec-97	15:06	7.11
6.70	87	R7a	R1B/DATA	200	S150C	4-Nov-97	09:43	13.26
6.83	216	R107a	R3A/DATA2	200	S150E	12-Dec-97	07:56	8.15
6.90	41	S7h	R1A/DATA	100	SCAN20B	2-Nov-97	23:13	3.39
7.00	39	C7h	R1A/DATA	100	SCAN72B	2-Nov-97	23:04	8.23
7.00	40	D7h	R1A/DATA	100	SCAN58B	2-Nov-97	23:10	9.48
7.00	42	R7h	R1A/DATA	100	SCAN150B	2-Nov-97	23:18	6.94
7.10	90	R6d	R1B/DATA	200	S150C	4-Nov-97	21:08	8.42
7.16	137	rg5a	R2A/DATA	100	S150E	3-Dec-97	13:04	14.91
7.20	92	R84a	R1B/DATA	200	S150C	4-Nov-97	22:27	11.08
7.23	185	Rn11a	R3A/DATA2	200	S150E	10-Dec-97	14:39	11.31
7.40	66	R7a	R1A/DATA2	200	SCAN150B	1-Nov-97	21:51	22.31
7.40	68	C7a	R1A/DATA2	200	SCAN72B	1-Nov-97	22:12	18.27
7.50	77	R7b	R1A/DATA2	200	SCAN150B	2-Nov-97	14:28	23.08
7.77	131	RF07b	R2A/DATA	200	S150E	3-Dec-97	09:25	19.60
7.96	130	RF08a	R2A/DATA	200	S150E	3-Dec-97	09:16	18.63
7.98	201	Rp08b	R3A/DATA2	200	S150E	10-Dec-97	23:17	10.96
8.56	144	rZ8a	R2A/DATA	100	S150E	3-Dec-97	17:48	13.06
8.74	147	RH8a	R2A/DATA2	200	S150E	3-Dec-97	18:36	11.33
8.80	156	RL09a	R3A/DATA	200	S150E	9-Dec-97	12:11	4.67
9.00	22	RAD31F	R1A/DATA	200	SCAN150	31-Oct-97	16:31	11.89
9.00	38	R8A	R1A/DATA	200	SCAN150B	1-Nov-97	07:42	16.49
9.00	99	R510a	R1B/DATA	200	S150C	4-Nov-97	23:30	8.05
9.04	146	rZ9a	R2A/DATA	100	S150E	3-Dec-97	18:24	12.49
9.37	202	Rp09b	R3A/DATA2	200	S150E	10-Dec-97	23:33	14.00
9.50	10	RAD30E	R1A/DATA	100	SCAN150	30-Oct-97	22:28	3.18
9.50	60	R9A	R1A/DATA2	200	SCAN150B	1-Nov-97	16:34	26.30
9.50	61	C9A	R1A/DATA2	200	SCAN72B	1-Nov-97	16:42	23.83
9.55	215	RI09b	R3A/DATA2	200	S150E	12-Dec-97	07:28	11.49
9.60	9	RAD30D	R1A/DATA	100	SCAN150	30-Oct-97	22:23	5.39
9.61	214	RI09a	R3A/DATA2	200	S150E	12-Dec-97	07:12	10.78
9.74	190	Rp10a	R3A/DATA2	200	S150E	10-Dec-97	15:48	8.64
10.00	11	RAD30F	R1A/DATA	200	SCAN150	30-Oct-97	22:44	10.71
10.00	21	RAD31E	R1A/DATA	200	SCAN150	31-Oct-97	12:35	18.10
10.00	62	D10A	R1A/DATA2	200	SCAN58B	1-Nov-97	16:48	12.34
10.00	63	S10A	R1A/DATA2	200	SCAN20B	1-Nov-97	16:53	10.45
10.00	64	R10B	R1A/DATA2	200	SCAN150B	1-Nov-97	17:02	28.87
10.12	191	Sp10a	R3A/DATA2	1500	S20x	10-Dec-97	16:10	7.76
10.17	179	Sn10a	R3A/DATA	1500	S20x	10-Dec-97	07:22	3.78
10.19	178	RN10a	R3A/DATA	200	S150E	10-Dec-97	07:11	4.48
10.30	100	CAL10a	R1B/DATA	200	S150C	4-Nov-97	23:39	8.48
10.37	175	RC10a	R3A/DATA	200	S150E	10-Dec-97	00:17	11.28
10.40	104	CAL20	R1B/DATA	200	S150C	5-Nov-97	00:38	9.75
10.67	192	Rp11a	R3A/DATA2	200	S150E	10-Dec-97	19:19	16.80
10.99	200	Rp09a	R3A/DATA2	200	S150E	10-Dec-97	23:05	12.96
11.01	138	rg10a	R2A/DATA	100	S150E	3-Dec-97	13:09	16.90
11.33	219	R112a	R3A/DATA2	200	S150E	12-Dec-97	09:29	10.45
11.44	168	RL11a	R3A/DATA	200	S150E	9-Dec-97	22:10	12.18
12.00	32	R20c	R1A/DATA	200	SCAN150	31-Oct-97	20:11	21.55
12.00	36	R24b	R1A/DATA	200	SCAN150	31-Oct-97	22:21	12.11
12.00	70	R12A	R1A/DATA2	200	SCAN150B	2-Nov-97	10:18	34.78
12.14	140	rl14a	R2A/DATA	100	S150E	3-Dec-97	14:37	13.61
12.19	220	RI12b	R3A/DATA2	200	S150E	12-Dec-97	12:02	5.75
12.61	141	rl15b	R2A/DATA	100	S150E	3-Dec-97	14:48	13.99
12.62	167	RL13c	R3A/DATA	200	S150E	9-Dec-97	21:19	5.27
12.71	132	RF13a	R2A/DATA	200	S150E	3-Dec-97	09:35	25.20
12.91	133	RF13b	R2A/DATA	200	S150E	3-Dec-97	09:53	24.09
12.92	177	RL14b	R3A/DATA	200	S150E	10-Dec-97	00:40	11.74
12.94	165	Sa15a	R3A/DATA	1500	S20x	9-Dec-97	18:19	4.55
12.96	139	rg13a	R2A/DATA	100	S150E	3-Dec-97	13:14	13.43
13.00	24	R20a	R1A/DATA	200	SCAN150	31-Oct-97	17:18	16.66
13.00	49	C138A	R1A/DATA2	200	SCAN72B	1-Nov-97	11:42	9.41
13.10	113	CT13A	R1B/DATA	200	S72C	5-Nov-97	10:47	10.43
13.23	164	RL13a	R3A/DATA	200	S150E	9-Dec-97	18:06	6.80
13.23	166	RL13b	R3A/DATA	200	S150E	9-Dec-97	21:03	6.45
13.61	154	RL15a	R3A/DATA	200	S150E	9-Dec-97	10:44	1.42
14.00	25	RU20a	R1A/DATA	200	SCAN150	31-Oct-97	17:28	15.92
14.00	26	R20b	R1A/DATA	200	SCAN150	31-Oct-97	17:38	7.02
14.00	71	R14a	R1A/DATA2	200	SCAN150B	2-Nov-97	11:04	17.12
14.11	198	Rp13a	R3A/DATA2	200	S150E	10-Dec-97	22:38	21.45
14.31	169	RL14a	R3A/DATA	200	S150E	9-Dec-97	22:23	9.80



Data Sets sorted by Ship Speed

Ave. Speed (knots)		File Name	Directory	Data Length	Scan Pattern	Date	Time	Max Wave Ht. (ft)
14.36	174	RC15a	R3A/DATA	200	S150E	10-Dec-97	00:04	7.60
14.50	13	CEN31A	R1A/DATA	100	SCAN72	31-Oct-97	07:22	3.45
14.50	14	DIA31A	R1A/DATA	100	SCAN58	31-Oct-97	07:27	3.41
14.50	118	RR15a	R1B/DATA	200	S150C	5-Nov-97	13:12	9.34
14.60	12	RAD31A	R1A/DATA	100	SCAN150	31-Oct-97	07:17	4.13
14.70	7	SIDE30B	R1A/DATA	100	SCAN20_1+10	30-Oct-97	16:28	2.74
14.70	8	DIA30B	R1A/DATA	100	SCAN58	30-Oct-97	16:31	1.59
15.20	114	CT16A	R1B/DATA	200	S72C	5-Nov-97	10:59	7.40
15.37	187	Rn15b	R3A/DATA2	200	S150E	10-Dec-97	15:06	11.94
15.41	186	Rn15a	R3A/DATA2	200	S150E	10-Dec-97	14:48	11.06
15.50	102	CAL15b	R1B/DATA	200	S150C	5-Nov-97	00:15	10.06
15.79	217	Rt16a	R3A/DATA2	200	S150E	12-Dec-97	08:55	13.13
15.90	101	CAL15	R1B/DATA	200	S150C	5-Nov-97	00:05	8.69
16.00	28	RU17a	R1A/DATA	200	SCAN150	31-Oct-97	18:53	17.88
16.00	29	RS17a	R1A/DATA	200	SCAN20_1+10	31-Oct-97	19:03	4.60
16.00	72	R17a	R1A/DATA2	200	SCAN150B	2-Nov-97	11:13	17.68
16.70	134	RF17c	R2A/DATA	200	S150E	3-Dec-97	10:10	14.60
16.88	161	Sa17a	R3A/DATA	1500	S20x	9-Dec-97	16:45	5.11
16.89	160	RL17A	R3A/DATA	200	S150E	9-Dec-97	16:33	5.90
17.00	27	R17c	R1A/DATA	200	SCAN150	31-Oct-97	18:34	7.06
17.00	30	RD17a	R1A/DATA	200	SCAN58	31-Oct-97	19:14	6.19
17.20	93	R17a	R1B/DATA	200	S150C	4-Nov-97	22:39	12.78
17.20	95	D17a	R1B/DATA	200	S58C	4-Nov-97	22:51	5.92
17.20	96	S17a	R1B/DATA	200	S20C	4-Nov-97	22:55	5.67
17.20	97	R17b	R1B/DATA	200	S150C	4-Nov-97	23:04	6.53
17.30	94	C17a	R1B/DATA	200	S72C	4-Nov-97	22:46	6.17
17.30	110	RM17b	R1B/DATA	200	S150C	5-Nov-97	10:01	10.43
17.30	112	DM17a	R1B/DATA	200	S58C	5-Nov-97	10:35	7.68
17.40	111	CM17a	R1B/DATA	200	S72C	5-Nov-97	10:23	9.20
17.70	105	RM17a	R1B/DATA	200	S150C	5-Nov-97	09:09	9.86
17.72	218	Rt17a	R3A/DATA2	200	S150E	12-Dec-97	09:13	13.82
18.00	31	RC19a	R1A/DATA	200	SCAN72	31-Oct-97	19:21	5.61
18.00	73	R18a	R1A/DATA2	200	SCAN150B	2-Nov-97	11:23	19.11
18.30	115	RT18A	R1B/DATA	100	S150C	5-Nov-97	11:12	8.48
18.87	204	Rq18a	R3A/DATA2	200	S150E	11-Dec-97	10:55	16.97
18.90	117	RR19b	R1B/DATA	200	S150C	5-Nov-97	12:47	7.78
19.04	205	Rq18b	R3A/DATA2	200	S150E	11-Dec-97	11:05	14.00
19.06	206	Rq19a	R3A/DATA2	200	S150E	11-Dec-97	11:32	17.11
19.10	116	RR19a	R1B/DATA	200	S150C	5-Nov-97	12:31	15.12
19.40	103	CAL19	R1B/DATA	200	S150C	5-Nov-97	00:25	9.06
20.00	57	R30C	R1A/DATA2	200	SCAN150B	1-Nov-97	13:48	32.05
20.00	65	OR15a	R1A/DATA2	200	SCAN150	1-Nov-97	21:42	36.18
20.00	74	R20a	R1A/DATA2	200	SCAN150B	2-Nov-97	11:33	18.78
20.20	172	RC20a	R3A/DATA	200	S150E	9-Dec-97	23:44	4.91
20.28	173	RC20b	R3A/DATA	200	S150E	9-Dec-97	23:54	6.65
20.73	194	Rp20b	R3A/DATA2	200	S150E	10-Dec-97	19:41	22.00
20.81	193	Rp20a	R3A/DATA2	200	S150E	10-Dec-97	19:28	17.37
21.00	23	RAD31H	R1A/DATA	200	SCAN150	31-Oct-97	16:41	6.58
21.10	157	RL21c	R3A/DATA	200	S150E	9-Dec-97	12:27	5.08
21.13	152	RL21a	R3A/DATA	200	S150E	9-Dec-97	10:23	9.09
21.16	153	RL21b	R3A/DATA	200	S150E	9-Dec-97	10:35	4.84
21.20	158	RL21d	R3A/DATA	200	S150E	9-Dec-97	12:48	5.84
21.26	159	Sa21a	R3A/DATA	1500	S20x	9-Dec-97	13:09	6.94
22.00	18	SIDE31A	R1A/DATA	200	SCAN20_1+10	31-Oct-97	09:46	4.75
22.00	19	DIA31B	R1A/DATA	200	SCAN58	31-Oct-97	09:51	7.00
22.00	20	CEN31B	R1A/DATA	200	SCAN72	31-Oct-97	09:58	6.06
22.00	75	R22a	R1A/DATA2	200	SCAN150B	2-Nov-97	11:43	19.83
22.00	127	RE22b	R2A/DATA	200	S150E	2-Dec-97	23:39	12.54
22.00	163	RLm28a	R3A/DATA	200	S150E	9-Dec-97	17:17	5.95
22.07	126	RE22a	R2A/DATA	200	S150E	2-Dec-97	23:24	13.18
22.09	125	RE24a	R2A/DATA	200	S150E	2-Dec-97	22:46	15.23
23.16	128	RF22a	R2A/DATA	200	S150E	3-Dec-97	07:56	22.27
23.19	129	RF22b	R2A/DATA	200	S150E	3-Dec-97	08:09	18.65
23.24	195	Rp21a	R3A/DATA2	200	S150E	10-Dec-97	19:53	9.06
23.39	170	RL23a	R3A/DATA	200	S150E	9-Dec-97	23:14	4.98
23.40	171	RL23b	R3A/DATA	200	S150E	9-Dec-97	23:32	5.13
24.00	35	R24a	R1A/DATA	200	SCAN150	31-Oct-97	21:20	43.21
25.00	37	R14b	R1A/DATA	200	SCAN150	31-Oct-97	22:32	7.77
25.40	149	RL25a	R3A/DATA	200	S150E	9-Dec-97	09:37	3.45
25.67	151	RL26b	R3A/DATA	200	S150E	9-Dec-97	09:56	3.65
25.69	150	RL26a	R3A/DATA	200	S150E	9-Dec-97	09:46	3.77
27.00	43	R27A	R1A/DATA2	200	SCAN150B	1-Nov-97	10:54	11.28

Data Sets sorted by Ship Speed

Ave. Speed (knots)		File Name	Directory	Data Length	Scan Pattern	Date	Time	Max Wave Ht. (ft)
27.00	44	R27B	R1A/DATA2	200	SCAN150B	1-Nov-97	11:04	11.37
27.00	45	C27A	R1A/DATA2	200	SCAN72B	1-Nov-97	11:11	7.92
27.00	46	D27A	R1A/DATA2	200	SCAN58B	1-Nov-97	11:21	9.49
27.00	47	S27A	R1A/DATA2	200	SCAN20B	1-Nov-97	11:25	5.56
27.00	48	R27C	R1A/DATA2	200	SCAN150B	1-Nov-97	11:34	12.17
27.00	53	D29A	R1A/DATA2	200	SCAN58B	1-Nov-97	13:12	19.01
27.35	211	Rq26a	R3A/DATA2	200	S150E	11-Dec-97	13:58	19.33
27.65	212	Rq27a	R3A/DATA2	200	S150E	11-Dec-97	14:16	10.27
27.85	162	RL28a	R3A/DATA	200	S150E	9-Dec-97	17:03	4.38
28.00	50	R28A	R1A/DATA2	200	SCAN150B	1-Nov-97	12:52	11.64
28.54	207	Rq28a	R3A/DATA2	200	S150E	11-Dec-97	13:02	12.12
28.55	210	Rq28c	R3A/DATA2	200	S150E	11-Dec-97	13:47	17.04
28.68	208	Rq28b	R3A/DATA2	200	S150E	11-Dec-97	13:13	7.69
28.69	209	Sq28a	R3A/DATA2	1500	S20x	11-Dec-97	13:26	8.01
29.00	52	S29A	R1A/DATA2	200	SCAN20B	1-Nov-97	13:07	16.11
30.00	51	R30A	R1A/DATA2	200	SCAN150B	1-Nov-97	13:02	32.50
30.00	54	C29A	R1A/DATA2	200	SCAN72B	1-Nov-97	13:18	9.01
31.00	55	R30B	R1A/DATA2	200	SCAN150B	1-Nov-97	13:27	11.71

## Appendix 3

### Contents

- page 1..... Figure 1, showing the hydrophone positions as seen from  
inside the sonar dome area.
- page 2..... Figure 2, showing the starboard half of the hydrophone  
positions
- page 3.....Figure 3, A 2-dimensional projection mapping of the  
hydrophone locations on the inside surface of the  
USS RADFORD monolithic sonar dome. This is the  
same mapping used in producing the color horizontal  
and vertical deflection graphs in Appendix 7.

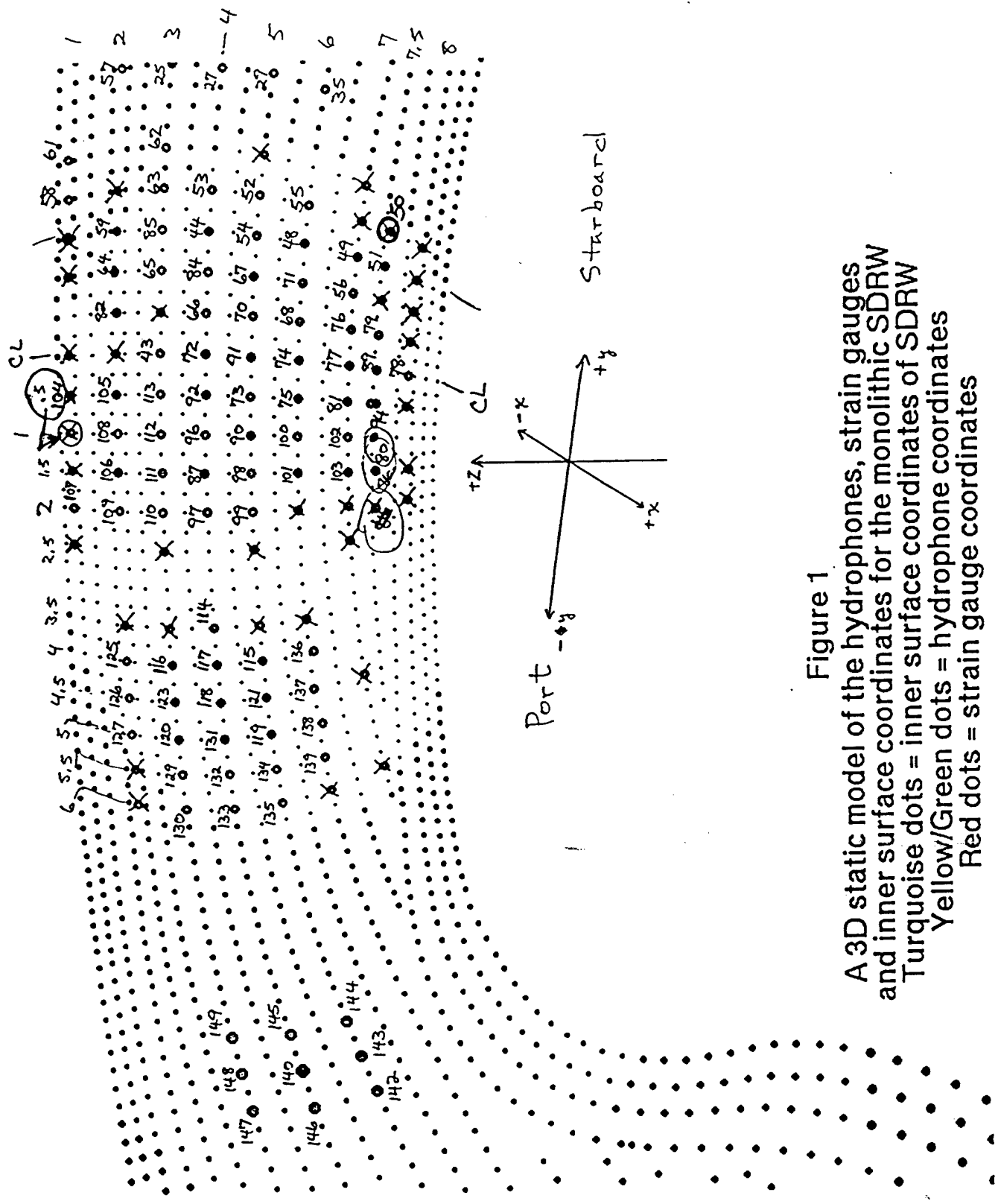

Figure 1  
 A 3D static model of the hydrophones, strain gauges and inner surface coordinates for the monolithic SDRW  
 Turquoise dots = inner surface coordinates of SDRW  
 Yellow/Green dots = hydrophone coordinates  
 Red dots = strain gauge coordinates

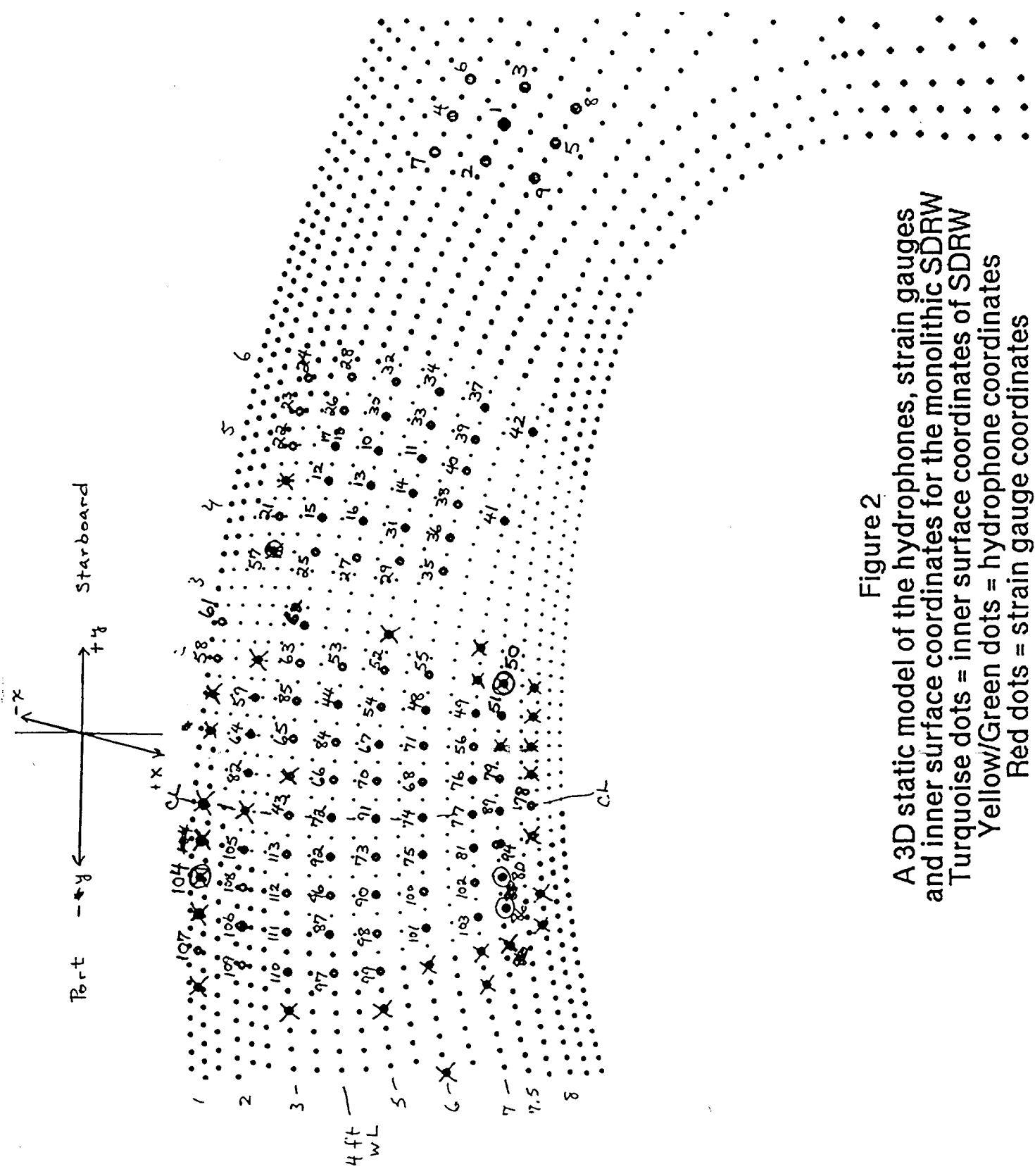
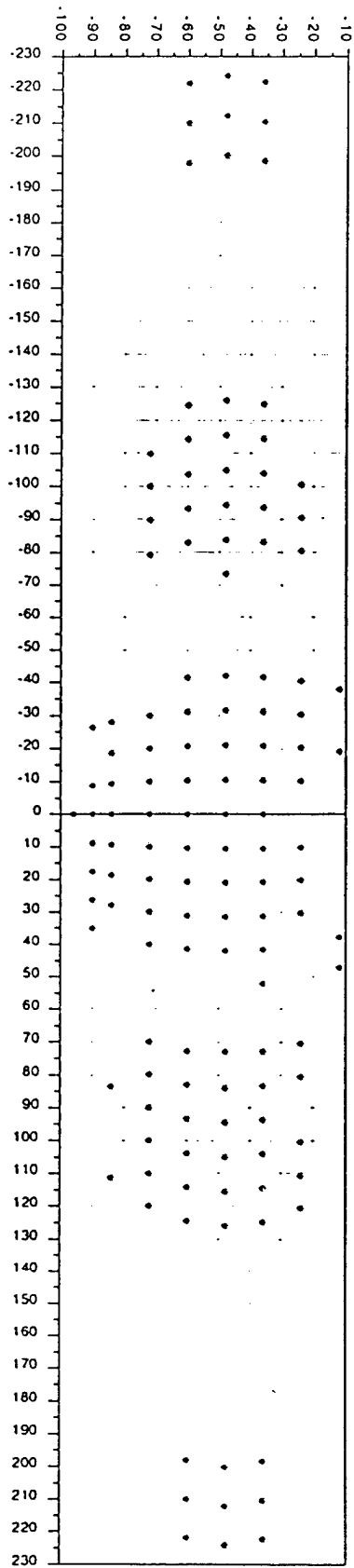

Figure 2  
 A 3D static model of the hydrophones, strain gauges  
 and inner surface coordinates for the monolithic SDRW  
 Turquoise dots = inner surface coordinates of SDRW  
 Yellow/Green dots = hydrophone coordinates  
 Red dots = strain gauge coordinates



## Appendix 4

The evolution of the main 150 hydrophone scan pattern. This scan pattern started on the starboard side at the 90 degree position and swept towards the bow and around to the port side. It was created in the same sequence as the numbering of the banks of receiver hydrophones. Within the group of displacement hydrophones using a particular receiver bank, the hydrophones were listed in order of the load cell module or star module addressed.

The numbers shown in each scan location consists of four numbers.

1st number: Receiver Bank used

2nd number: Module number (#'s 1-8 were Load Cell modules, 9-14 were Star Modules)

3rd number: Element selected (Load Cells usually had 8, Star Modules 16)

4th number: The amplification code (the decimal equivalent to the actual binary code)

During pierside calibration no computer controlled amplification was needed on any of the hydrophones. Thus the first change needed in the scan pattern was a complete rechecking of all received signals once at-sea to determine which hydrophones required amplification. The amount of amplification depends on the ship speed and the sea state. Also, particular hydrophones which were performing poorly had to be replaced in the scan pattern as their signals dropped below threshold.

In the list, changes in the scan pattern are shown in Red when they first occur.

	SCAN150	SCAN150B	S150C	S150E
1	01-01-04-0000	01-01-04-0000	01-01-04-0000	01-01-04-0000
2	01-09-01-0000	01-09-01-0000	01-09-01-0000	01-09-01-0000
3	01-09-02-0000	01-09-02-0000	01-09-02-0000	01-09-02-0000
4	01-09-03-0000	01-09-03-0000	01-09-03-0000	01-09-03-0000
5	01-09-04-0000	01-09-04-0000	01-09-04-0000	01-09-04-0000
6	01-09-05-0000	01-09-05-0000	01-09-05-0000	01-09-05-0000
7	01-09-06-0000	01-09-06-0000	01-09-06-0000	01-09-06-0000
8	01-09-07-0000	01-09-07-0000	01-09-07-0000	01-09-07-0000
9	01-09-08-0000	01-09-08-0000	01-09-08-0000	01-09-08-0000
10	02-01-01-0000	02-01-01-0000	02-01-01-0000	02-01-01-0000
11	02-01-02-0000	02-01-02-0000	02-01-02-0000	02-01-02-0000
12	02-01-03-0000	02-01-03-0000	02-01-03-0000	02-01-03-0000
13	02-01-05-0000	02-01-05-0000	02-01-05-0000	02-01-05-0000
14	02-01-06-0000	02-01-06-0000	02-01-06-0000	02-01-06-0000
15	02-01-07-0000	02-01-07-0000	02-01-07-0000	02-01-07-0000
16	02-01-08-0000	02-01-08-0064	02-01-08-0064	02-01-08-0064
17	02-05-01-0000	02-05-01-0000	02-05-01-0000	02-05-01-0000
18	02-05-02-0000	02-05-02-0000	02-05-02-0000	02-05-02-0000
19	02-05-05-0000	02-05-05-0000	02-05-05-0000	02-05-05-0000
20	02-05-06-0000	02-05-06-0000	02-05-06-0000	02-05-06-0000
21	02-09-10-0000	02-09-10-0000	02-09-10-0000	02-09-10-0000
22	02-09-12-0000	02-09-12-0000	02-09-12-0000	02-09-12-0000
23	02-09-13-0000	02-09-13-0000	02-09-13-0000	02-09-13-0000
24	02-09-14-0000	02-09-14-0000	02-09-14-0000	02-09-14-0000
25	02-09-15-0000	02-09-15-0000	02-09-15-0000	02-09-15-0000
26	02-09-16-0000	02-09-16-0000	02-09-16-0000	02-09-16-0000
27	02-10-01-0000	02-10-01-0000	02-10-01-0000	02-10-01-0065
28	02-10-02-0000	02-10-02-0000	02-10-02-0000	02-10-02-0000
29	02-10-03-0000	02-10-03-0064	02-10-03-0064	02-10-03-0064
30	02-10-04-0000	02-10-04-0000	02-10-04-0000	02-10-04-0000
31	02-10-05-0000	02-10-05-0064	02-10-05-0064	02-10-05-0064
32	02-10-06-0000	02-10-06-0000	02-10-06-0000	02-10-06-0000
33	02-10-07-0000	02-10-07-0000	02-10-07-0000	02-10-07-0000
34	02-10-08-0000	02-10-08-0512	02-10-08-0512	02-10-08-0512
35	02-10-09-0000	02-10-09-0064	02-10-09-0064	02-10-09-0000
36	02-10-10-0000	02-10-10-0064	02-10-10-0064	02-10-10-0000
37	02-10-11-0000	02-10-11-0000	02-10-11-0000	02-10-11-0000
38	02-10-12-0000	02-10-12-0000	02-10-12-0000	02-10-12-0000
39	02-10-13-0000	02-10-13-0000	02-10-13-0000	02-10-13-0000
40	02-10-14-0000	02-10-14-0000	02-10-14-0000	02-10-14-0000
41	02-10-15-0000	02-10-15-0000	02-10-15-0000	02-10-15-0000
42	02-10-16-0000	02-10-16-0512	02-10-16-0512	02-10-16-0512
43	03-04-02-0000	03-04-02-0585	03-04-02-0585	03-04-02-0585
44	03-05-03-0000	03-05-03-0000	03-05-03-0000	03-05-03-0000
45	03-05-04-0000	03-05-04-0000	03-05-04-0000	03-05-04-0000
46	03-05-07-0000	03-05-07-0000	03-05-07-0000	03-05-07-0000
47	03-05-08-0000	03-05-08-0000	03-05-08-0000	03-05-08-0000
48	03-06-05-0000	03-06-05-0000	03-06-05-0000	03-06-05-0000
49	03-06-06-0000	03-06-06-0000	03-06-06-0000	03-06-06-0000
50	03-06-07-0000	03-06-07-0000	03-06-07-0000	03-06-07-0000
51	03-06-08-0000	03-06-08-0000	03-06-08-0000	03-06-08-0000
52	03-11-03-0000	03-11-03-0000	03-11-03-0000	03-11-03-0000
53	03-11-11-0000	03-11-11-0064	03-11-11-0064	03-11-11-0064
54	03-11-12-0000	03-11-12-0000	03-11-12-0000	03-11-12-0000
55	03-11-15-0000	03-11-15-0000	03-11-15-0000	03-11-15-0000



	SCAN150	SCAN150B	S150C	S150E
56	03-13-01-0000	03-13-01-0000	03-13-01-0000	03-13-01-0000
57	04-04-01-0000	04-09-09-0000	04-09-09-0000	04-09-09-0000
58	04-06-01-0000	04-06-01-0000	04-06-01-0000	04-06-01-0000
59	04-06-02-0000	04-06-02-0000	04-06-02-0000	04-06-02-0000
60	04-09-09-0000	04-09-09-0000	04-09-09-0000	04-09-09-0000
61	04-11-01-0000	04-11-01-0000	04-11-01-0000	04-11-01-0000
62	04-11-05-0000	04-11-05-0512	04-11-05-0512	04-11-05-0000
63	04-11-06-0000	04-11-06-0000	04-11-06-0000	04-11-06-0000
64	04-11-07-0000	04-11-07-0000	04-11-07-0000	04-11-07-0000
65	04-11-09-0000	04-11-09-0064	04-11-09-0064	04-11-09-0064
66	05-06-03-0000	05-06-03-0512	05-06-03-0512	05-06-03-0000
67	05-06-04-0000	05-06-04-0512	05-06-04-0512	05-06-04-0512
68	05-08-07-0000	05-08-07-0000	05-08-07-0000	05-08-07-0000
69	05-08-08-0000	05-08-08-0000	05-08-08-0000	05-08-08-0000
70	05-11-13-0000	05-11-13-0512	05-11-13-0512	05-11-13-0512
71	05-11-14-0000	05-11-14-0000	05-11-14-0000	05-11-14-0000
72	05-11-16-0000	05-11-16-0064	05-11-16-0064	05-11-16-0064
73	05-12-10-0000	05-12-10-0000	05-12-10-0000	05-12-10-0000
74	05-12-13-0000	05-12-13-0000	05-12-13-0000	05-12-13-0000
75	05-12-14-0000	05-12-14-0000	05-12-14-0000	05-12-14-0000
76	05-13-02-0000	05-13-02-0000	05-13-02-0000	05-13-02-0000
77	05-13-03-0000	05-13-03-0000	05-13-03-0000	05-13-03-0000
78	05-13-04-0000	05-13-04-0000	05-13-04-0000	05-13-04-0000
79	05-13-05-0000	05-13-05-0000	05-13-05-0000	05-13-05-0000
80	05-13-07-0000	05-13-07-0000	05-13-07-0000	05-13-07-0000
81	06-02-02-0000	06-02-02-0512	06-02-02-0512	06-02-02-0512
82	06-08-01-0000	06-08-01-0000	06-08-01-0000	06-08-01-0000
83	06-08-02-0000	06-08-02-0000	06-08-02-0000	06-08-02-0000
84	06-11-02-0000	06-11-02-0576	06-11-02-0576	06-11-02-0576
85	06-11-08-0000	06-11-08-0000	06-11-08-0000	06-11-08-0000
86	07-02-01-0000	07-02-01-0000	07-02-01-0000	07-02-01-0000
87	07-03-01-0000	07-03-01-0000	07-03-01-0000	07-03-01-0000
88	07-03-02-0000	07-03-02-0000	07-03-02-0000	07-03-02-0000
89	07-04-06-0000	07-04-06-0064	07-04-06-0064	07-04-06-0064
90	07-04-07-0000	07-04-07-0000	07-04-07-0000	07-04-07-0000
91	07-04-08-0000	07-04-08-0001	07-04-08-0001	07-04-08-0001
92	07-08-03-0000	07-08-03-0000	07-08-03-0000	07-08-03-0000
93	07-08-04-0000	07-08-04-0000	07-08-04-0008	07-08-04-0008
94	07-08-05-0000	07-08-05-0000	07-08-05-0000	07-08-05-0000
95	07-08-06-0000	07-08-06-0000	07-08-06-0000	07-08-06-0000
96	07-12-08-0000	07-12-08-0008	07-12-08-0008	07-12-08-0008
97	07-12-09-0000	07-12-09-0000	07-12-09-0000	07-12-09-0000
98	07-12-11-0000	07-12-11-0000	07-12-11-0000	07-12-11-0000
99	07-12-12-0000	07-12-12-0000	07-12-12-0000	07-12-12-0000
100	07-12-15-0000	07-12-15-0000	07-12-15-0000	07-12-15-0000
101	07-12-16-0000	07-12-16-0000	07-12-16-0000	07-12-16-0000
102	07-13-06-0000	07-13-06-0064	07-13-06-0064	07-13-06-0000
103	07-13-08-0000	07-13-08-0000	07-13-08-0000	07-13-08-0000
104	08-04-03-0000	08-04-03-0000	08-04-03-0000	08-04-03-0000
105	08-04-04-0000	08-04-04-0000	08-04-04-0000	08-04-04-0000
106	08-04-05-0000	08-04-05-0000	08-04-05-0000	08-04-05-0000
107	08-12-01-0000	08-12-01-0000	08-12-01-0000	08-12-01-0000
108	08-12-02-0000	08-12-02-0000	08-12-02-0000	08-12-02-0000
109	08-12-03-0000	08-12-03-0000	08-12-03-0000	08-12-03-0000
110	08-12-04-0000	08-12-04-0000	08-12-04-0000	08-12-04-0000

	SCAN150	SCAN150B	S150C	S150E
111	08-12-05-0000	08-12-05-0000	08-12-05-0000	08-12-05-0000
112	08-12-06-0000	08-12-06-0000	08-12-06-0000	08-12-06-0000
113	08-12-07-0000	08-12-07-0000	08-12-07-0000	08-12-07-0000
114	08-13-09-0000	08-13-09-0072	08-13-09-0072	08-13-09-0000
115	09-02-03-0000	09-02-03-0000	09-02-03-0000	09-02-03-0000
116	09-02-04-0000	09-02-04-0000	09-02-04-0000	09-02-04-0000
117	09-02-05-0000	09-02-05-0000	09-02-05-0008	09-02-05-0008
118	09-02-06-0000	09-02-06-0000	09-02-06-0000	09-02-06-0000
119	09-02-07-0000	09-02-07-0000	09-02-07-0000	09-02-07-0000
120	09-02-08-0000	09-02-08-0000	09-02-08-0000	09-02-08-0000
121	09-03-03-0000	09-03-03-0000	09-03-03-0000	09-03-03-0000
122	09-03-04-0000	09-03-04-0000	09-03-04-0000	09-03-04-0000
123	09-03-05-0000	09-03-05-0000	09-03-05-0000	09-03-05-0000
124	09-03-06-0000	09-03-06-0000	09-03-06-0000	09-03-06-0000
125	09-13-10-0000	09-13-10-0064	09-13-10-0064	09-13-10-0000
126	09-13-11-0000	09-13-11-0000	09-13-11-0000	09-13-11-0000
127	09-13-12-0000	09-13-12-0000	09-13-12-0000	09-13-12-0000
128	09-13-13-0000	09-13-13-0000	09-13-11-0000	09-13-11-0000
129	09-13-14-0000	09-13-14-0000	09-13-14-0000	09-13-14-1170
130	09-13-15-0000	09-13-15-0000	09-13-15-0000	09-13-15-0000
131	09-13-16-0000	09-13-16-0000	09-13-16-0000	09-13-16-0000
132	09-14-01-0000	09-14-01-0000	09-14-01-0000	09-14-01-0000
133	09-14-02-0000	09-14-02-0000	09-14-02-0000	09-14-02-0000
134	09-14-03-0000	09-14-03-0000	09-14-03-0000	09-14-03-0000
135	09-14-04-0000	09-14-04-0064	09-14-04-0064	09-14-04-0000
136	09-14-05-0000	09-14-05-0000	09-14-05-0000	09-14-05-0000
137	09-14-06-0000	09-14-06-0000	09-14-06-0000	09-14-06-0000
138	09-14-07-0000	09-14-07-0000	09-14-07-0000	09-14-07-0000
139	09-14-08-0000	09-14-08-0000	09-14-08-0000	09-14-08-0000
140	10-03-07-0000	10-03-07-0000	10-03-07-0000	10-03-07-0000
141	10-03-08-0000	10-03-08-0000	10-03-08-0000	10-03-08-0000
142	10-14-09-0000	10-14-09-0000	10-14-09-0000	10-14-09-0000
143	10-14-10-0000	10-14-10-0000	10-14-10-0000	10-14-10-0000
144	10-14-11-0000	10-14-11-0064	10-14-11-0064	10-14-11-0064
145	10-14-12-0000	10-14-12-0000	10-14-12-0000	10-14-12-0000
146	10-14-13-0000	10-14-13-0000	10-14-13-0000	10-14-13-0000
147	10-14-14-0000	10-14-14-0000	10-14-14-0000	10-14-14-0000
148	10-14-15-0000	10-14-15-0000	10-14-15-0000	10-14-15-0000
149	10-14-16-0000	10-14-16-0000	10-14-16-0000	10-14-16-0000
150	10-14-14-0000	10-14-14-0000	10-14-14-0000	10-14-14-0000

## Appendix 5

Sonar Dome Environmental Parameter Data Sheets

Listed in alphabetical order by file name

# RC05a Environmental Data

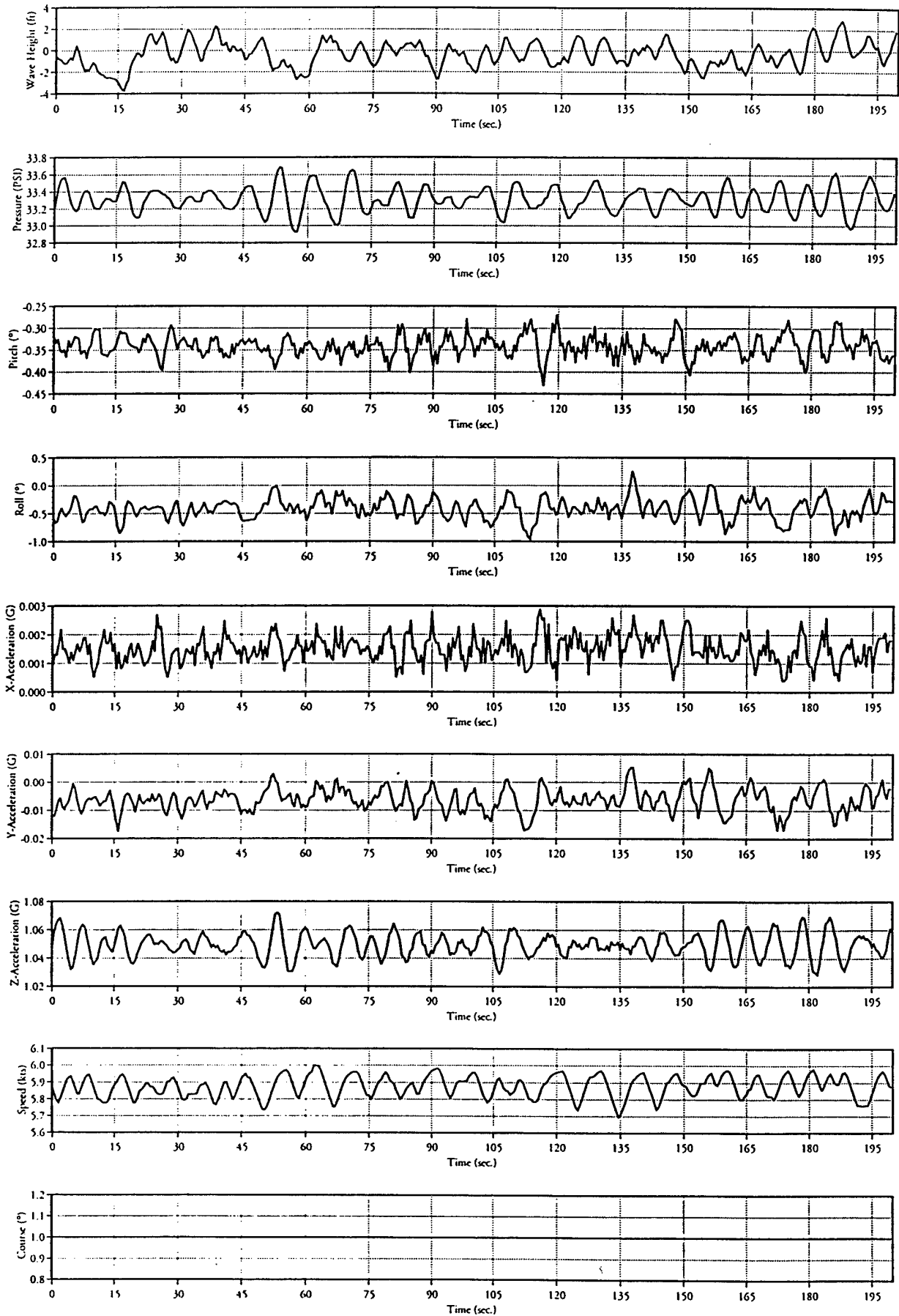

# RC15a Environmental Data

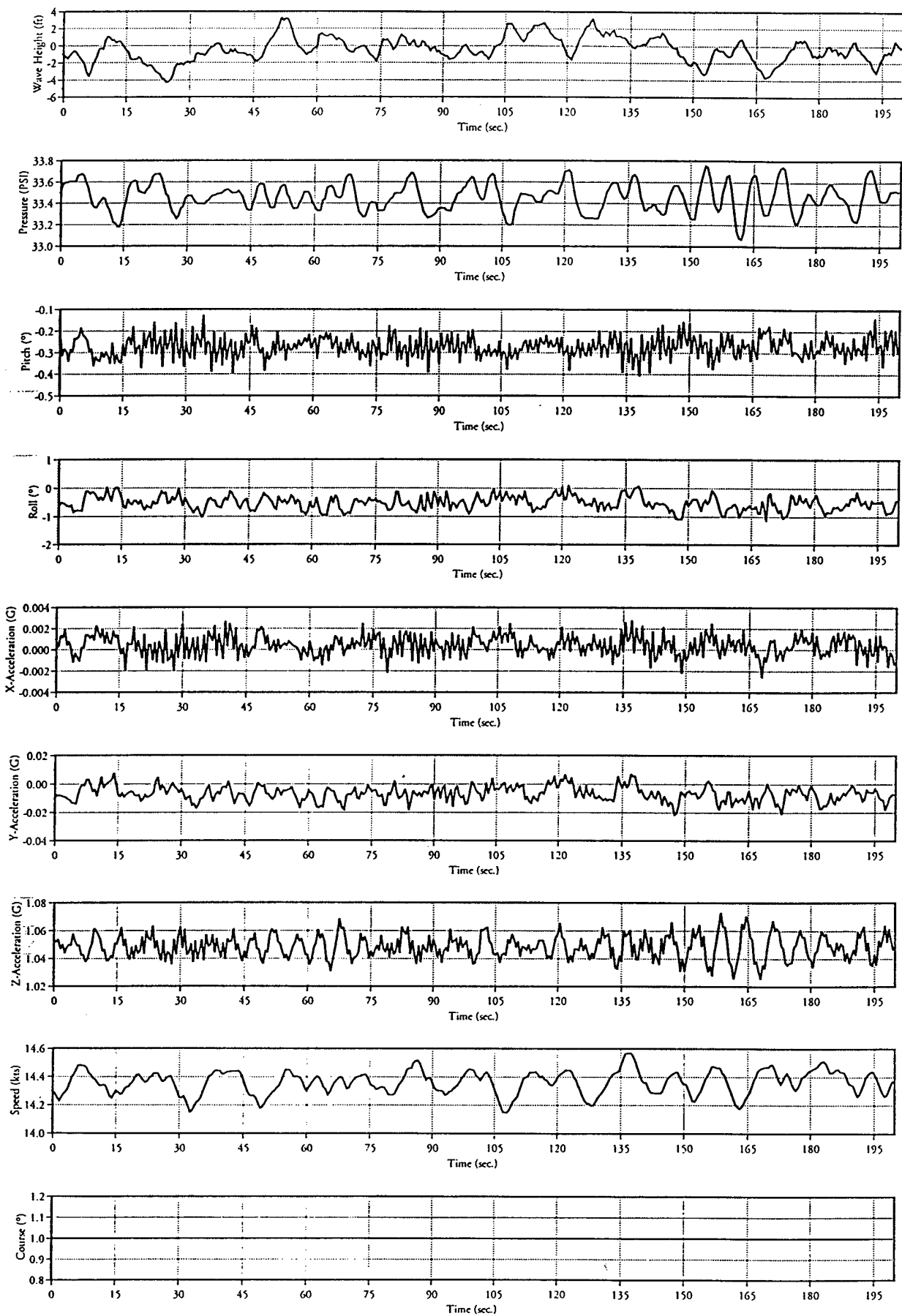

# RC10a Environmental Data

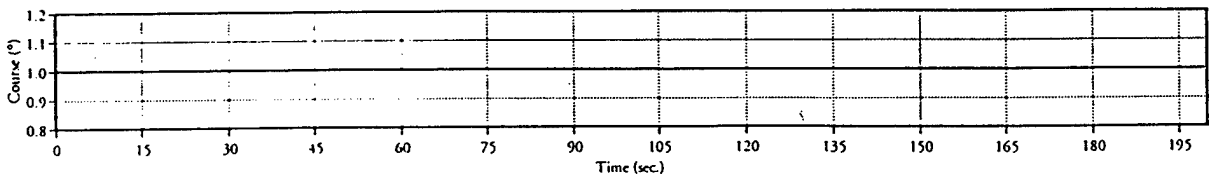
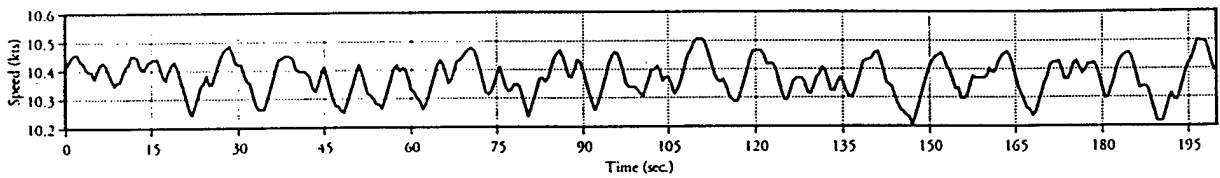
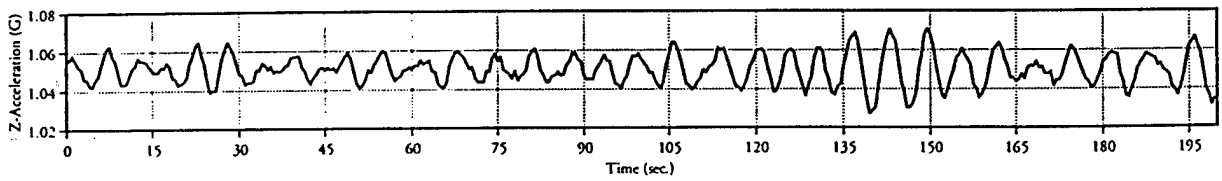
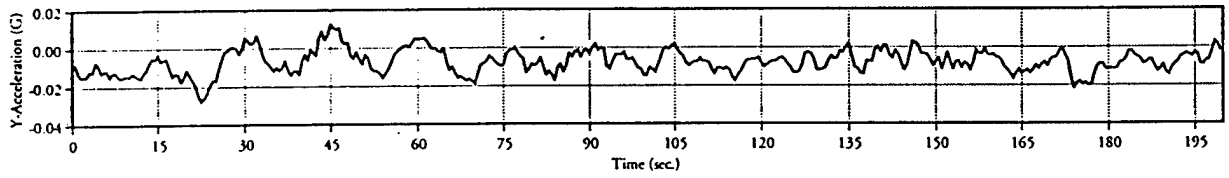
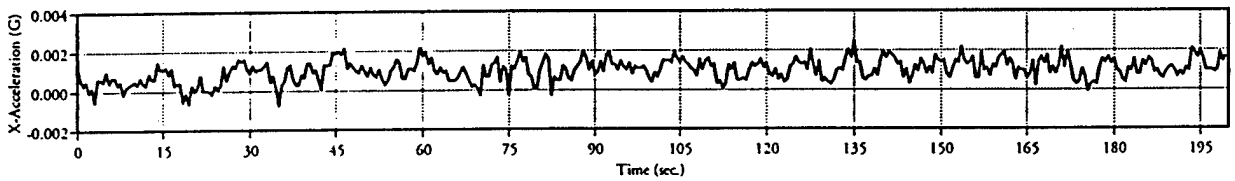
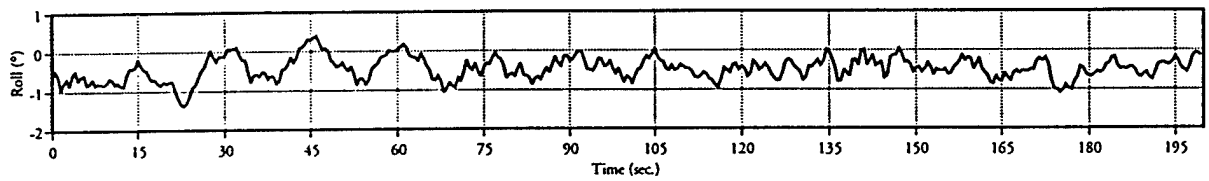
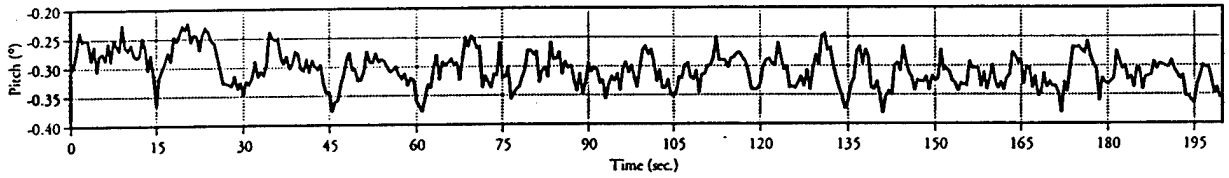
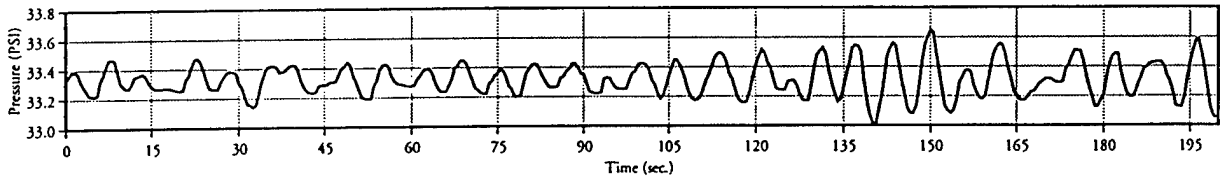
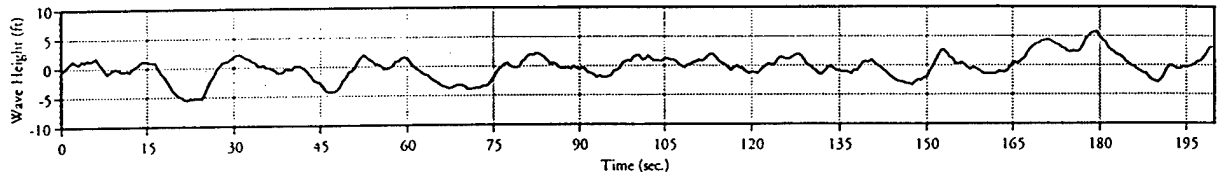

# RC19a Environmental Data

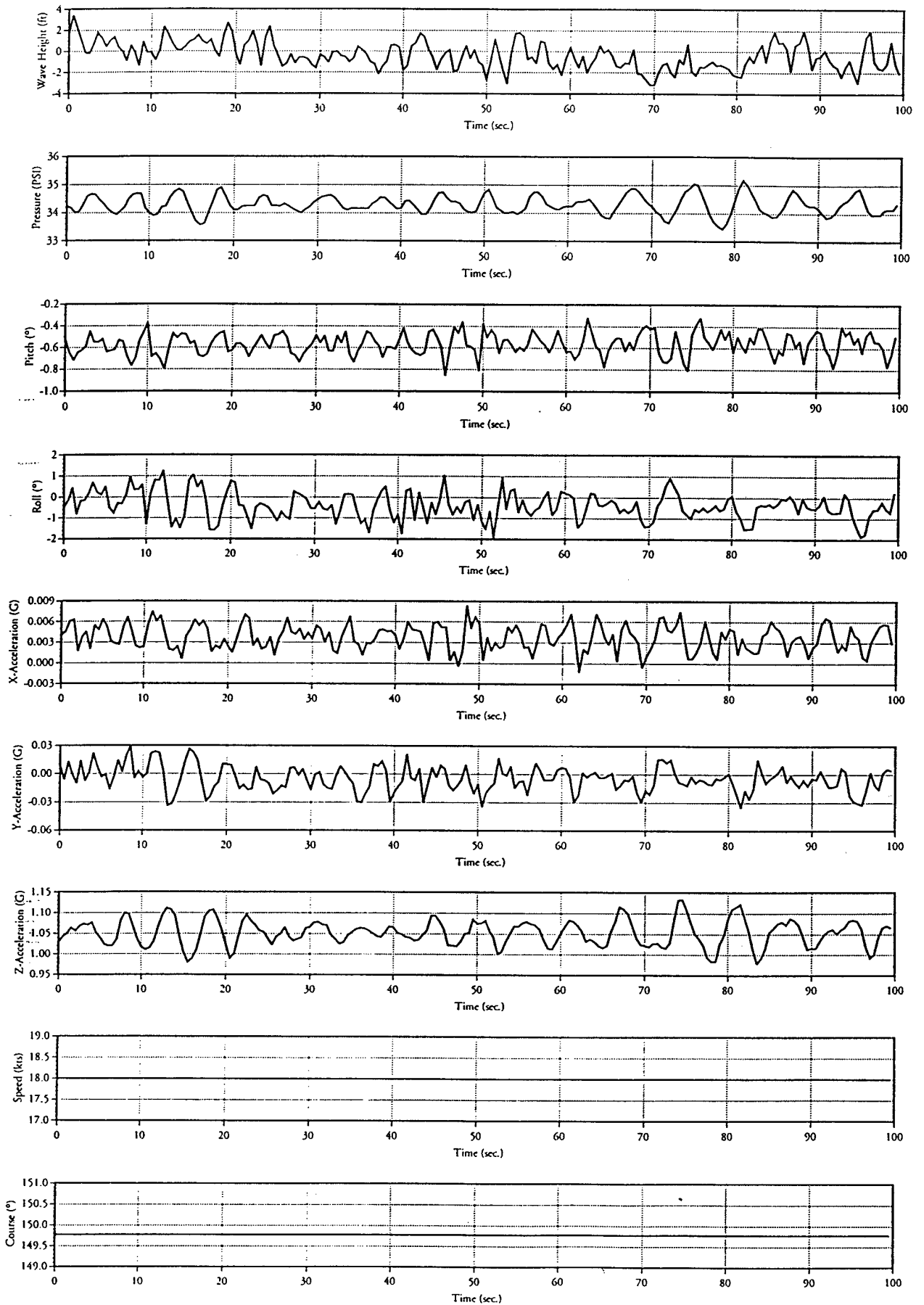

# RC20a Environmental Data

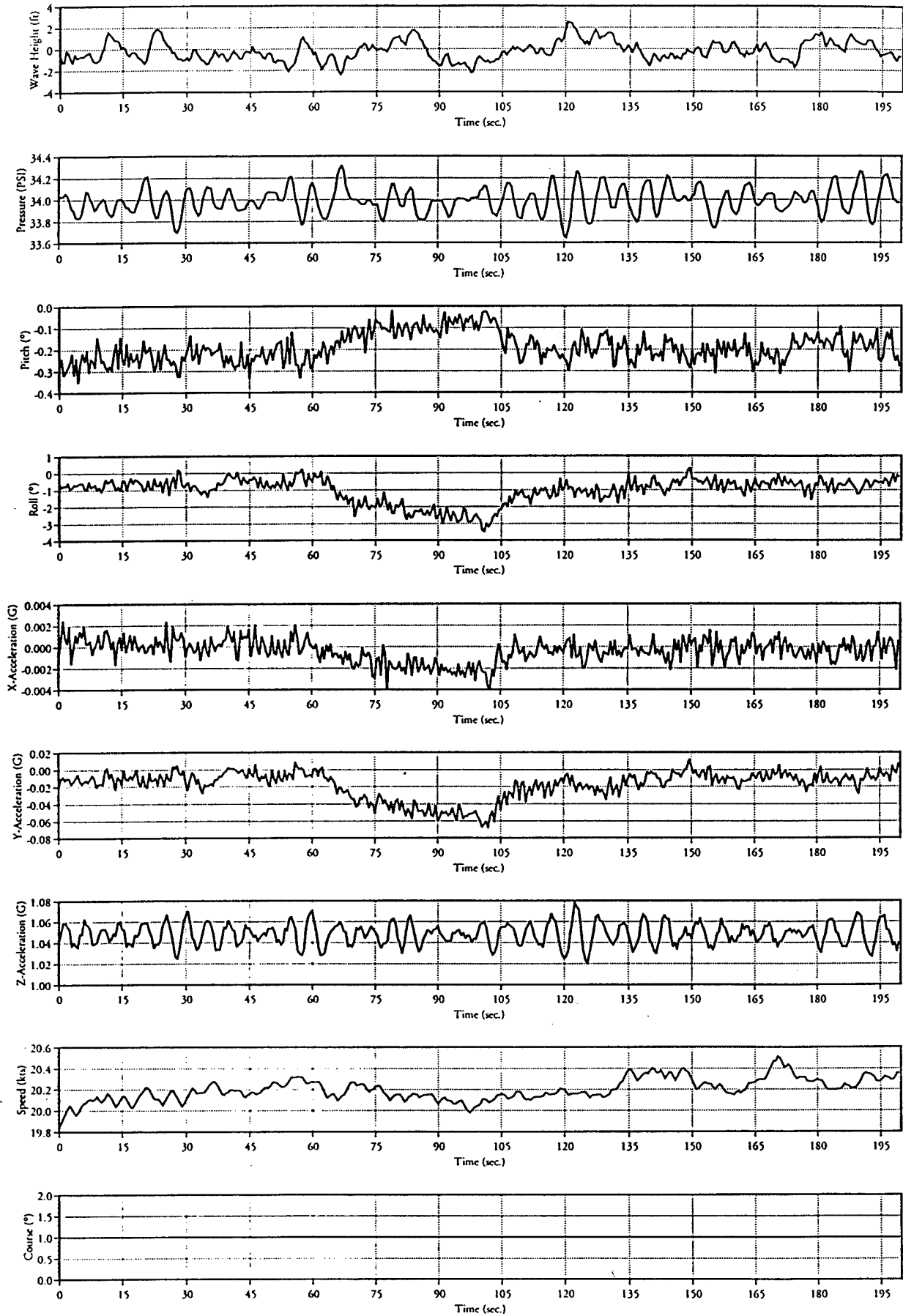



# RC20b Environmental Data

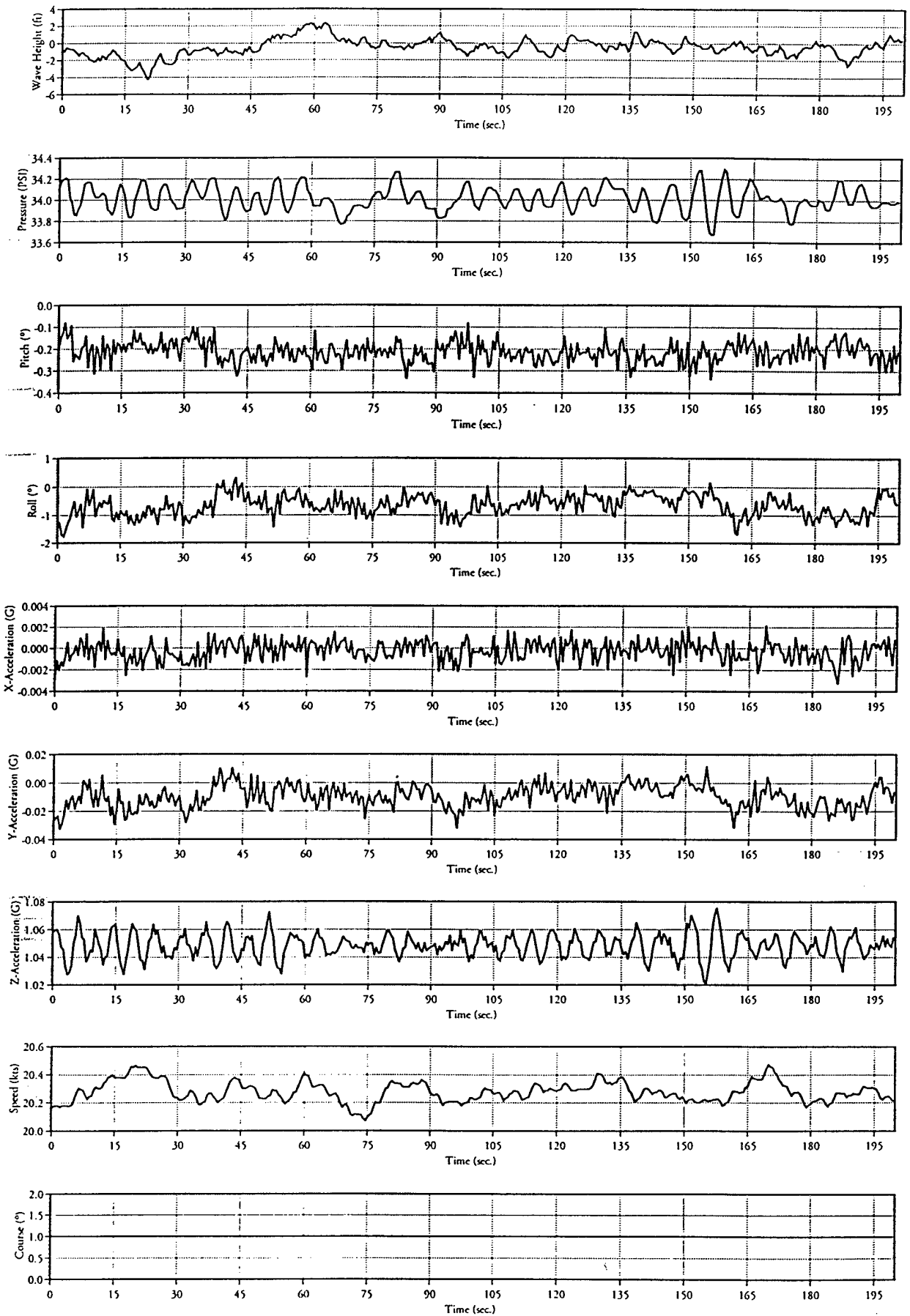

# RD17a Environmental Data

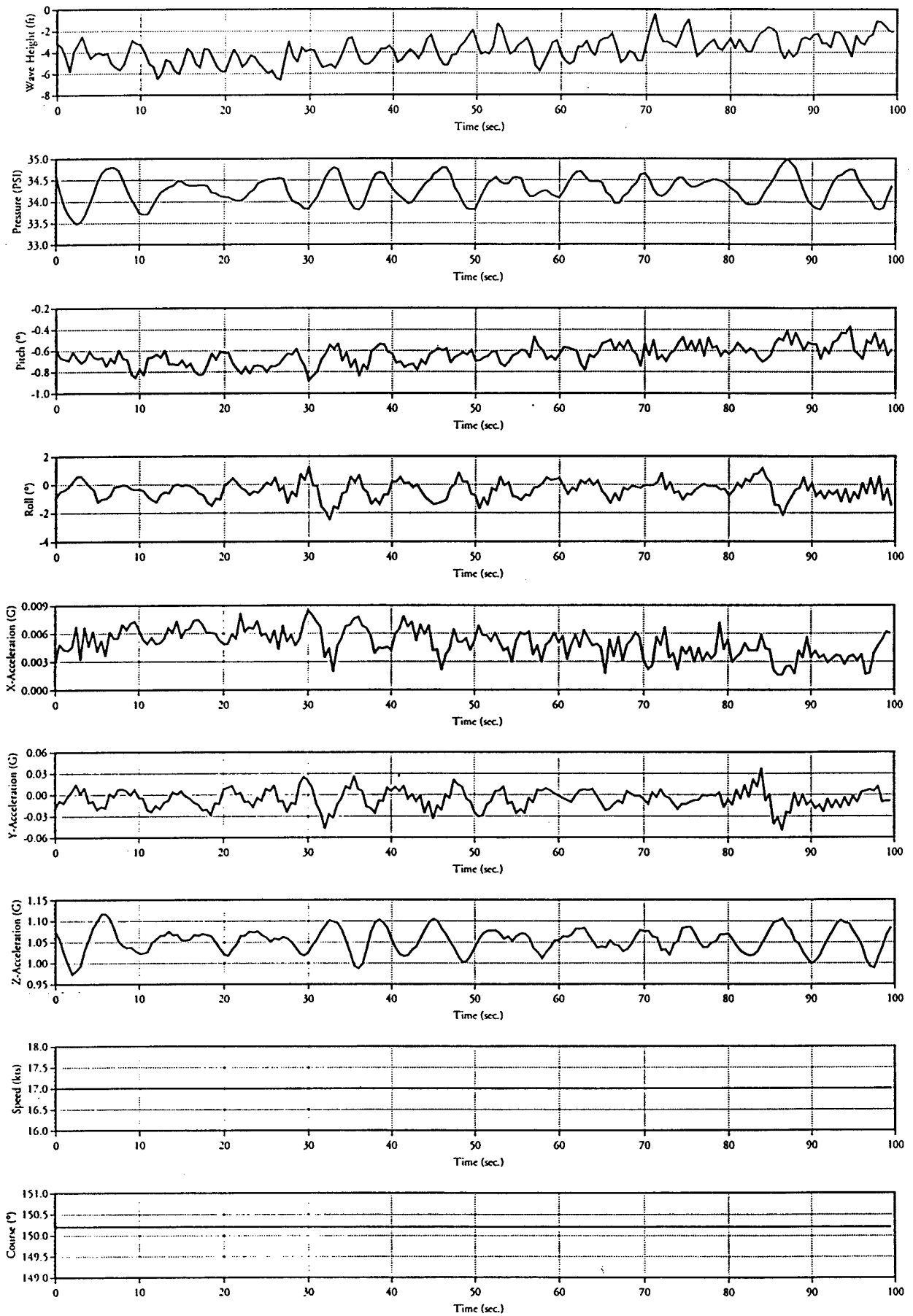

# RE22a Environmental Data

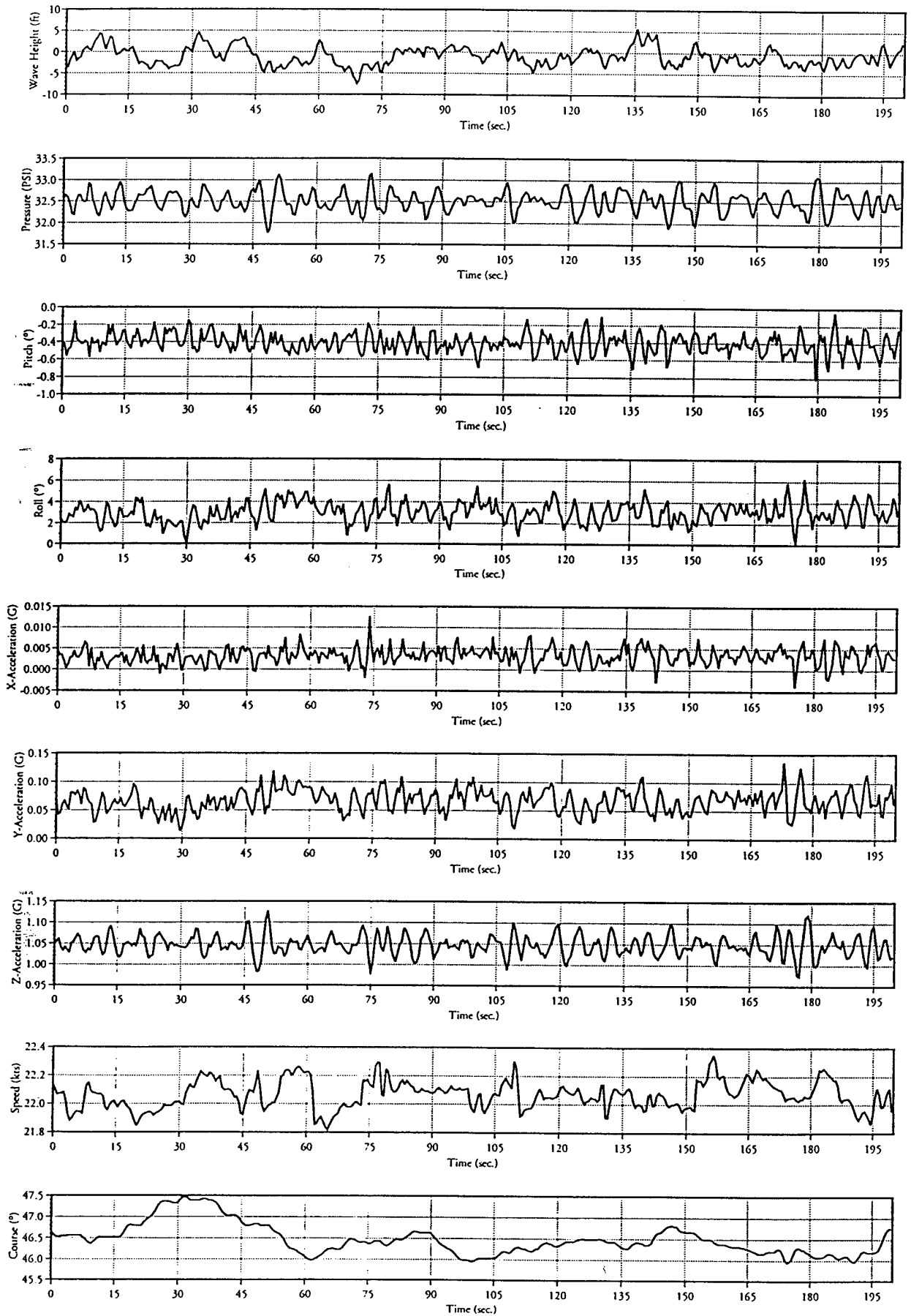

# RE22b Environmental Data

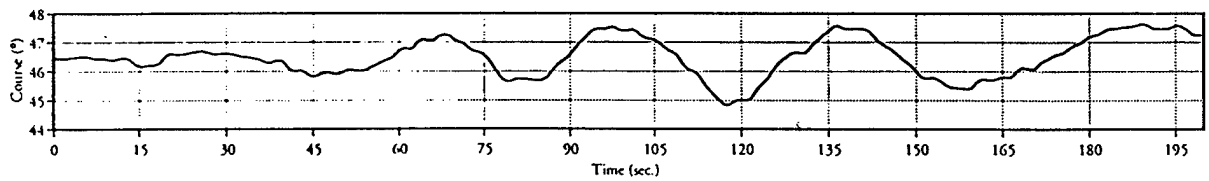
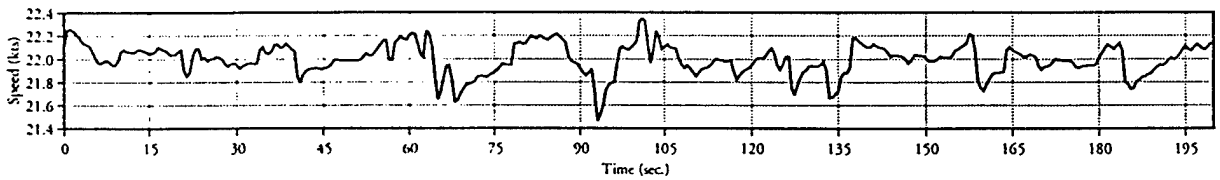
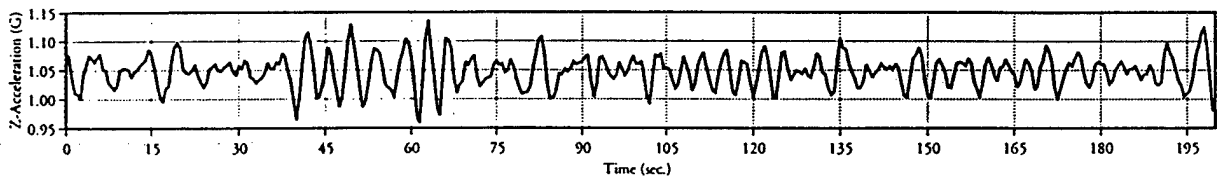
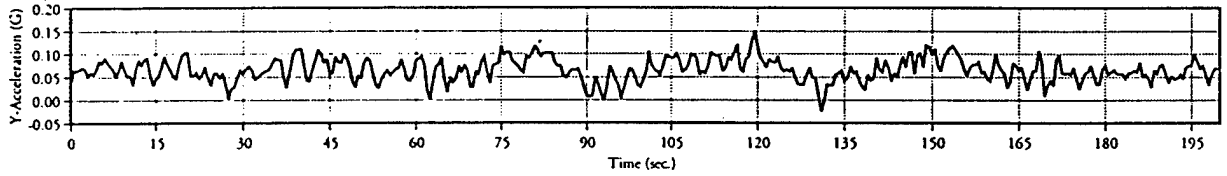
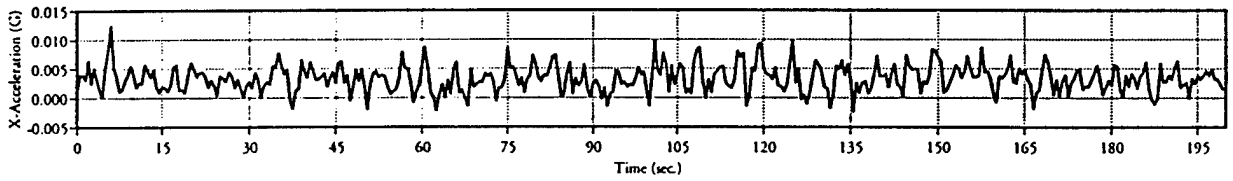
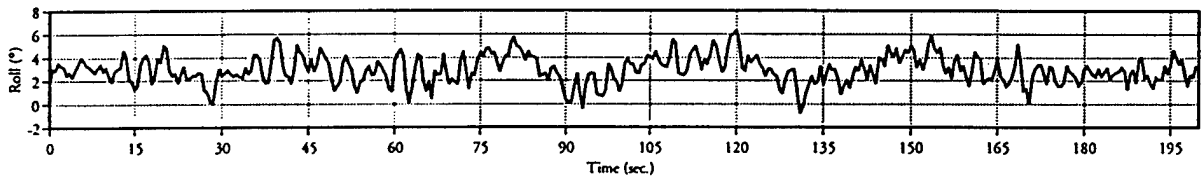
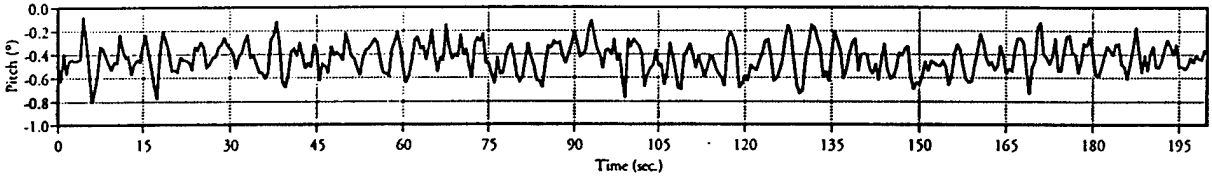
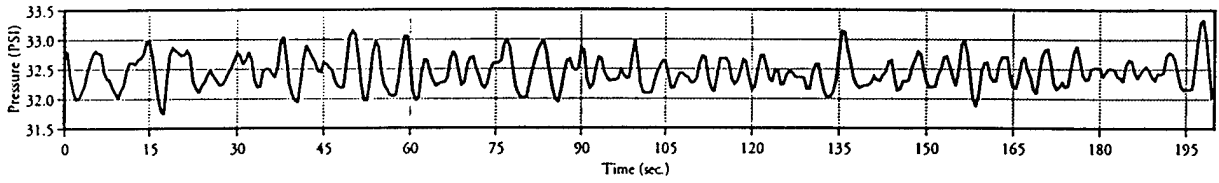
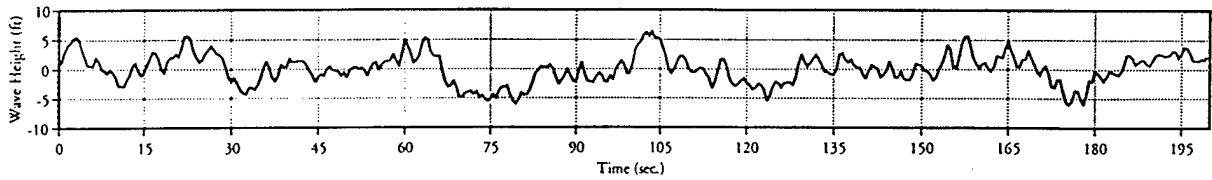

# RE24a Environmental Data

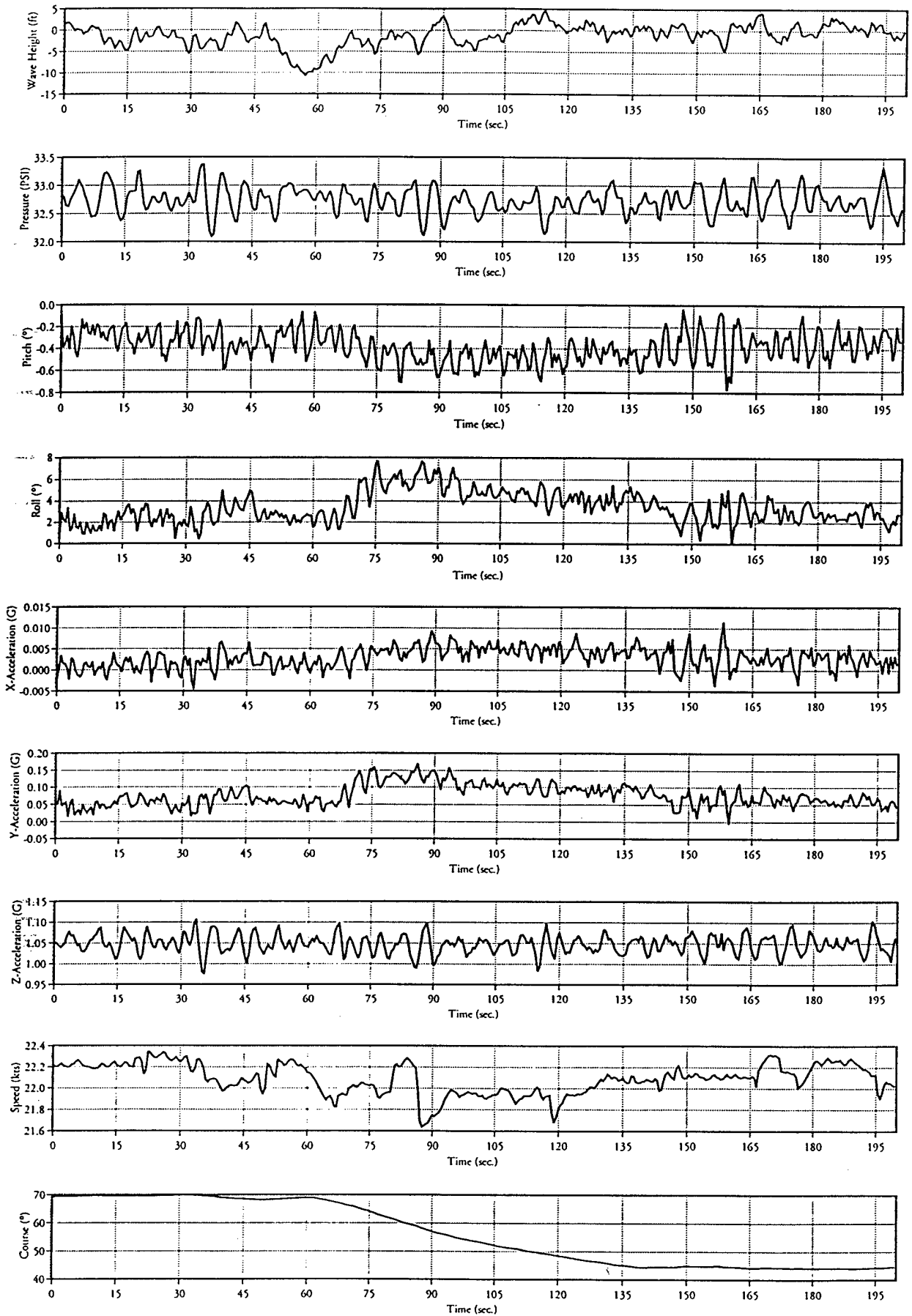

# RF02a Environmental Data

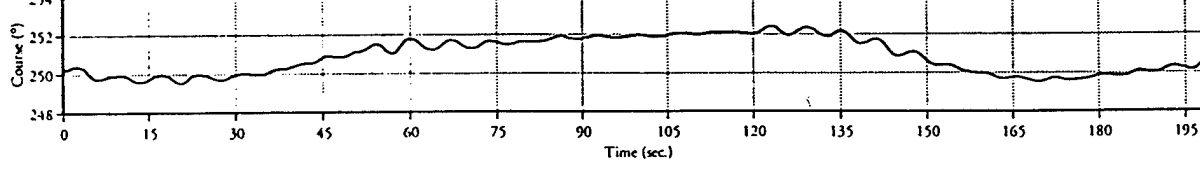
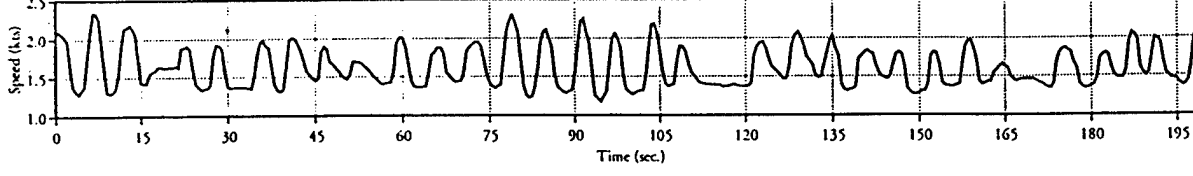
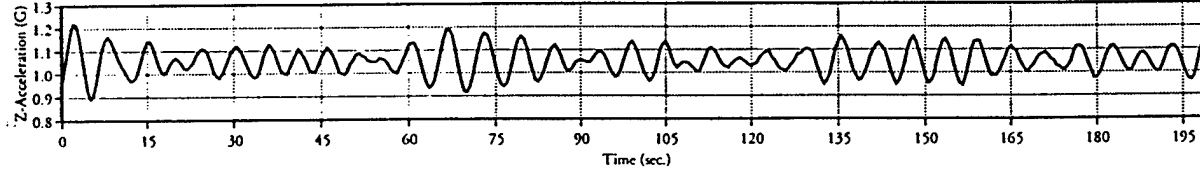
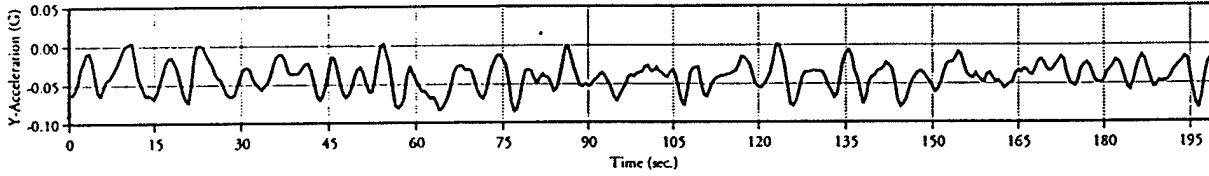
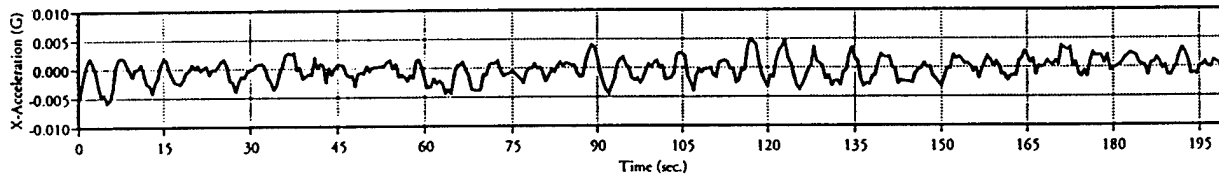
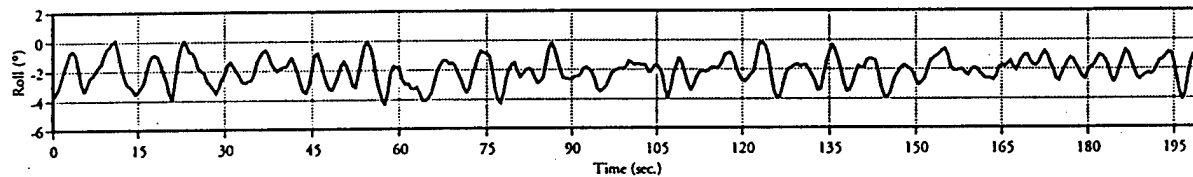
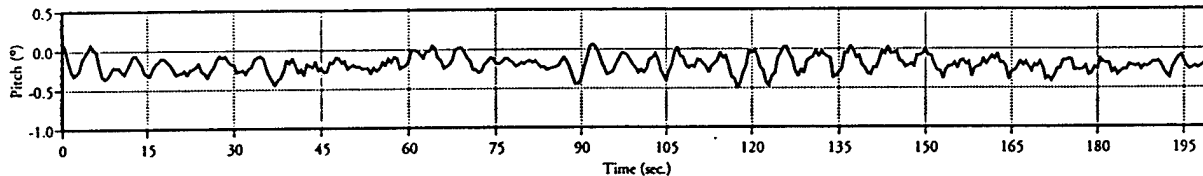
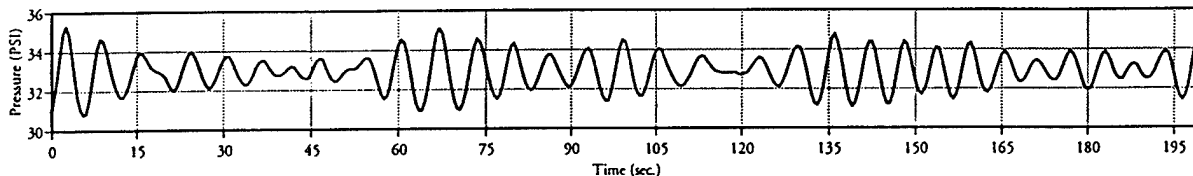
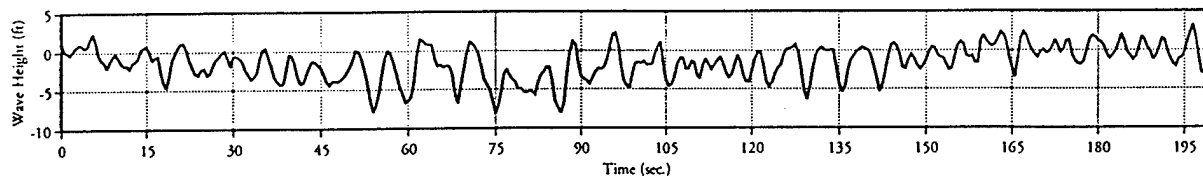

# RF02b Environmental Data

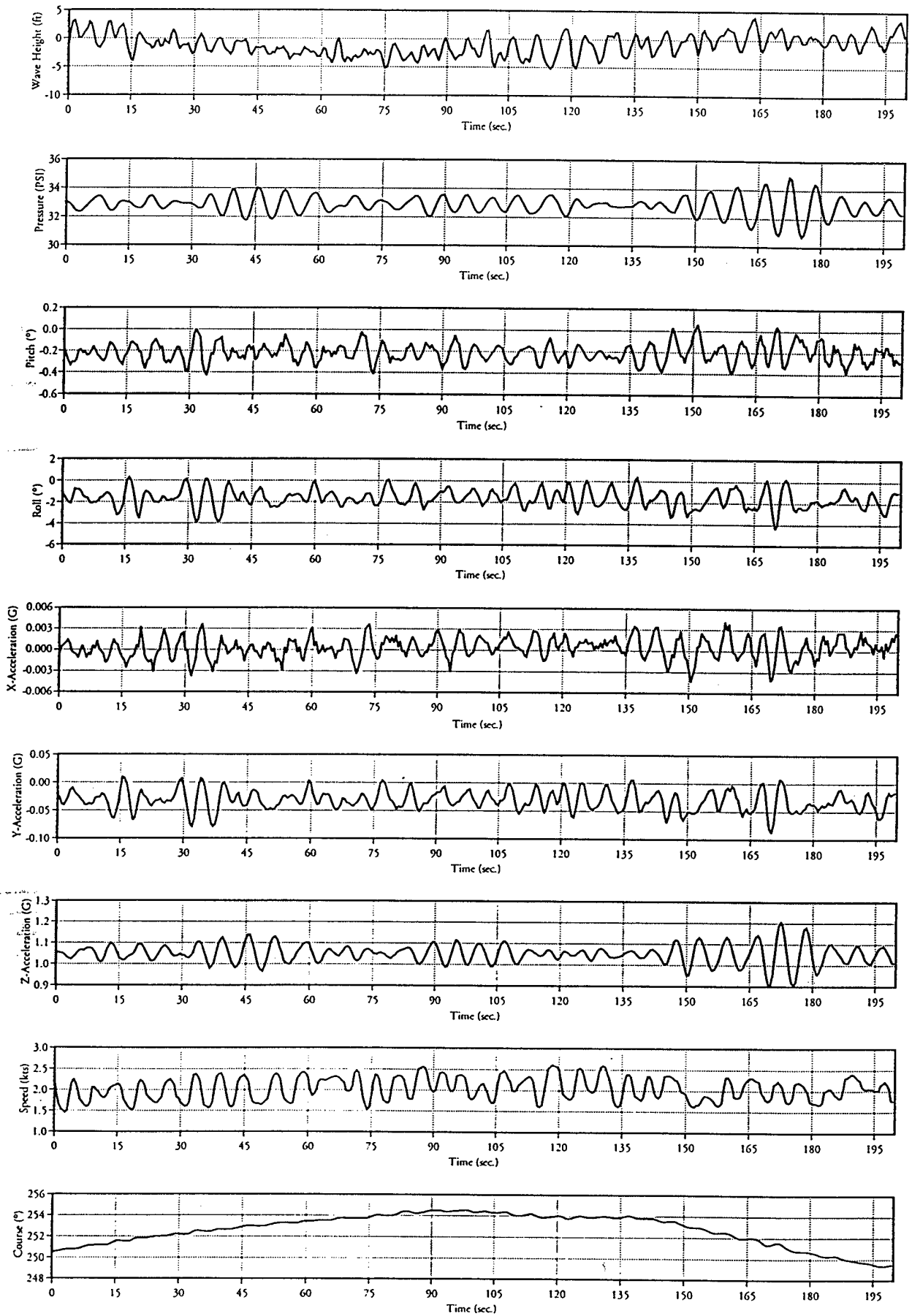

# RF07b Environmental Data

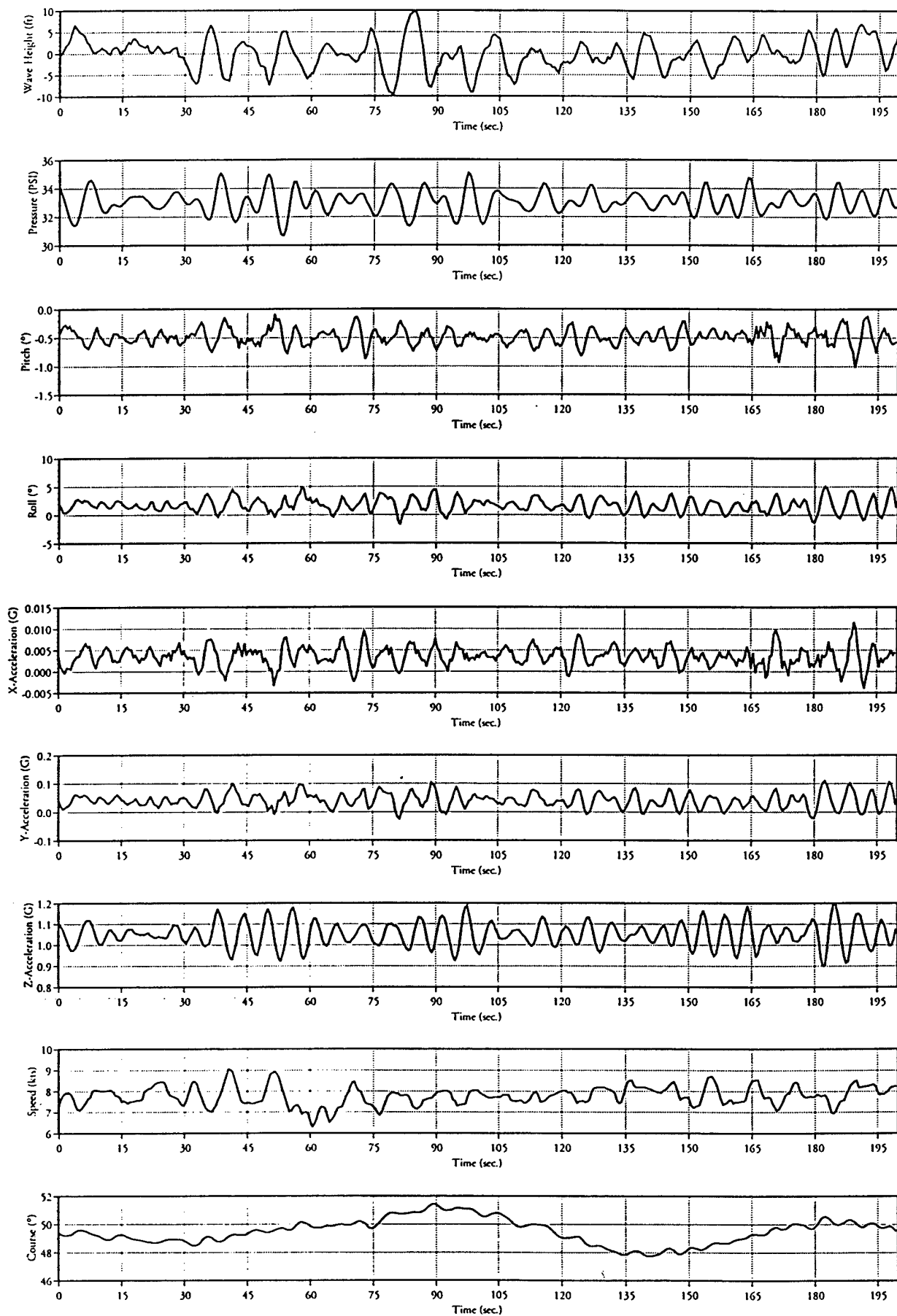



# RF08a Environmental Data

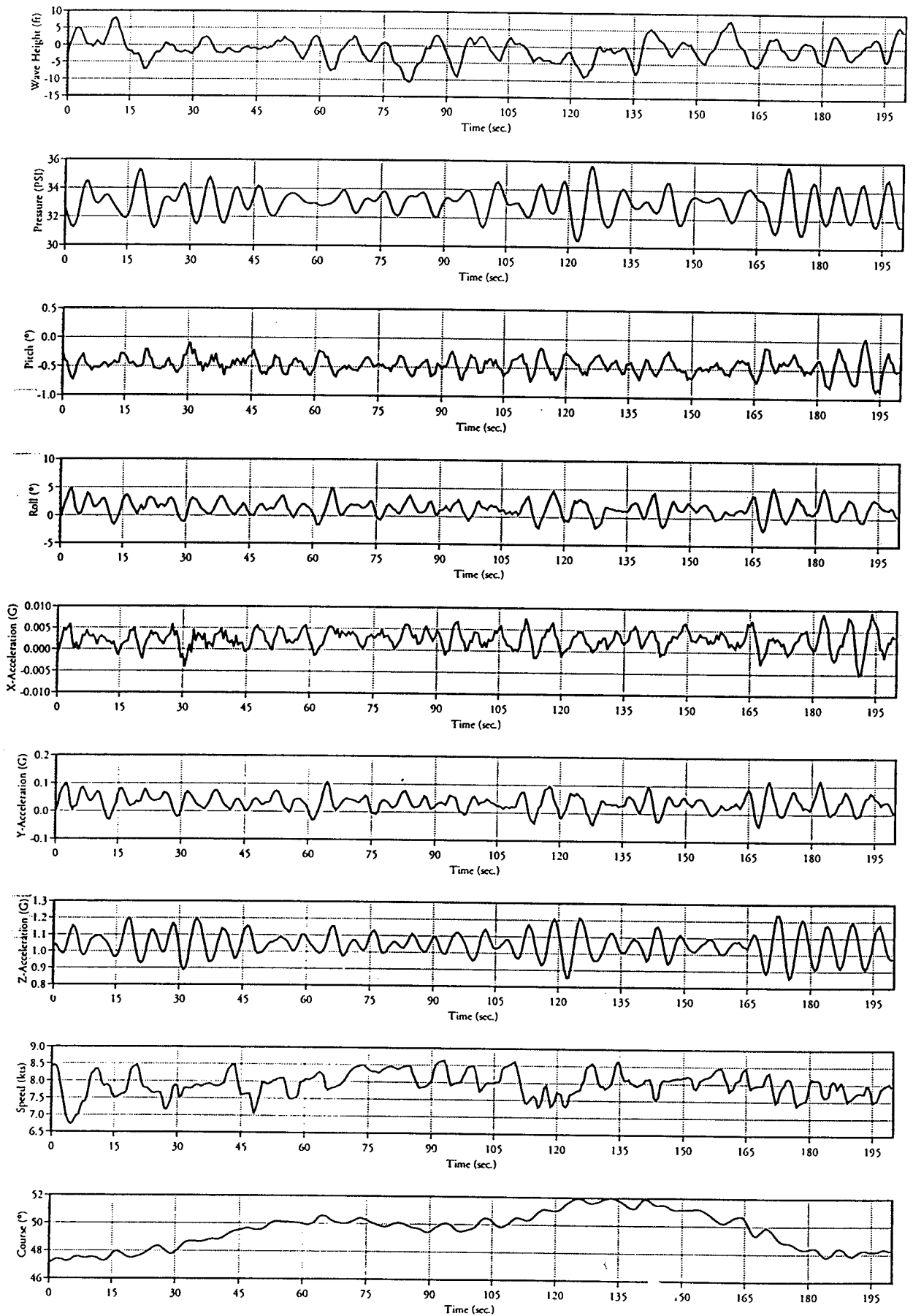

# RF13a Environmental Data

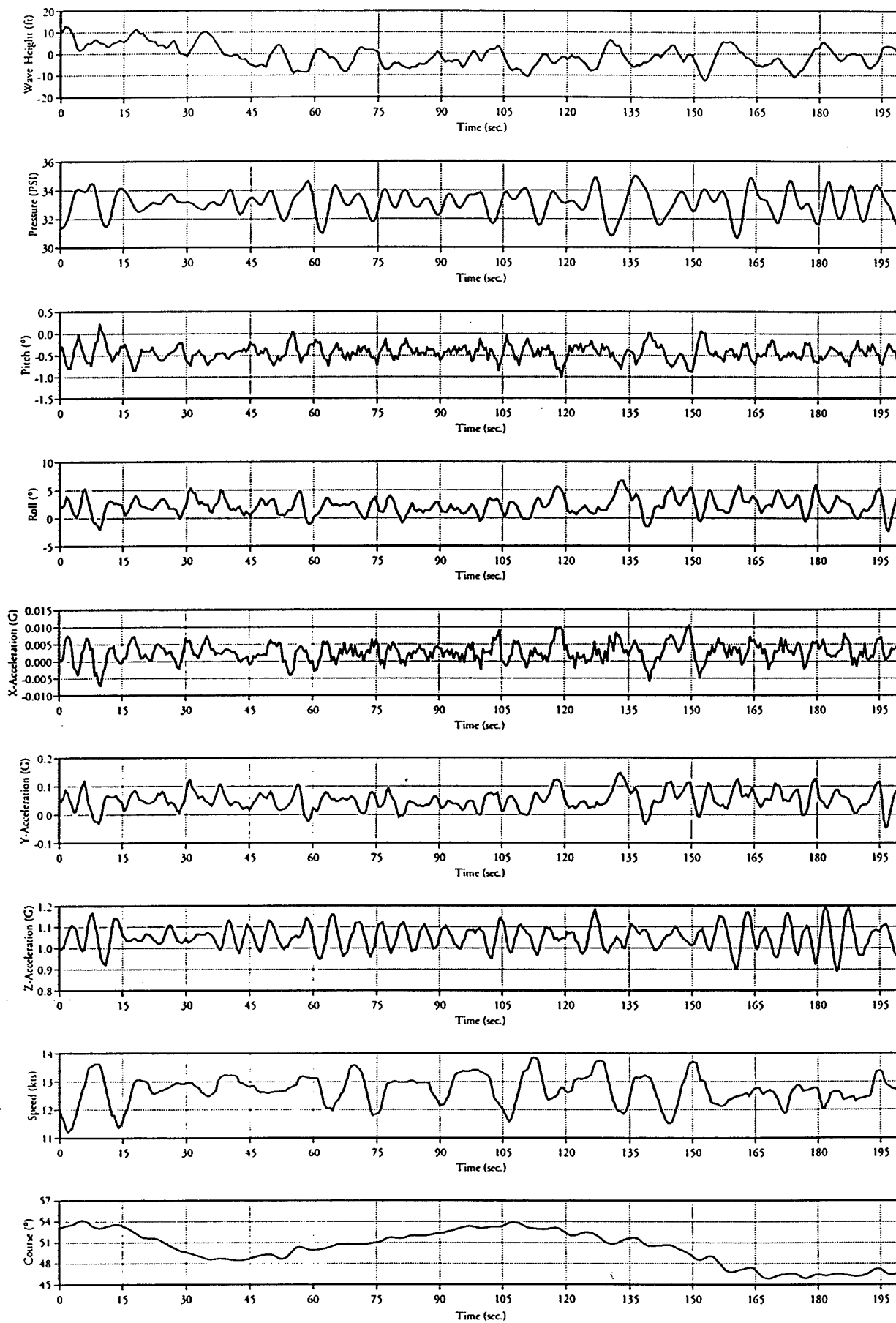

# RF13b Environmental Data

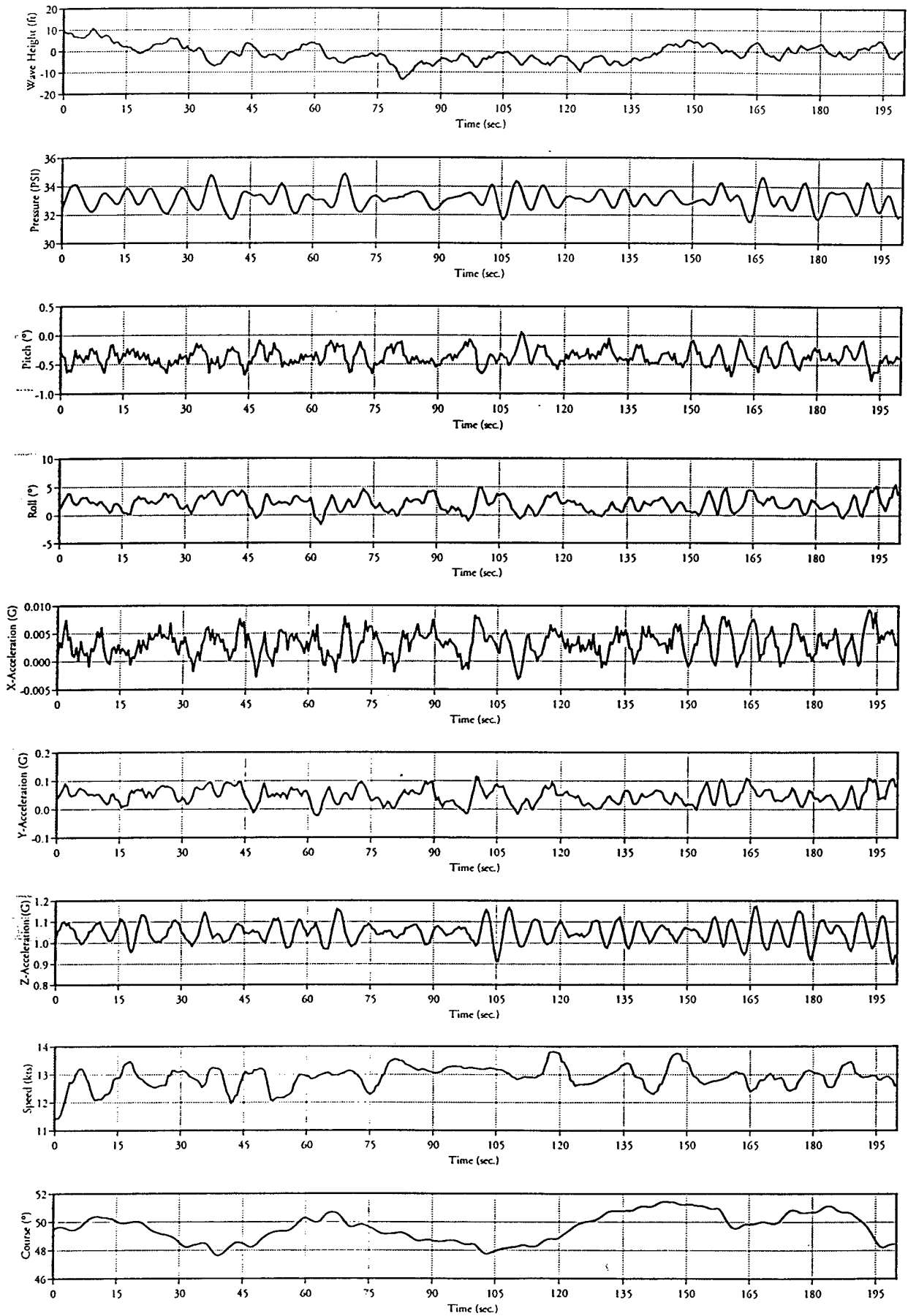

# RF17c Environmental Data

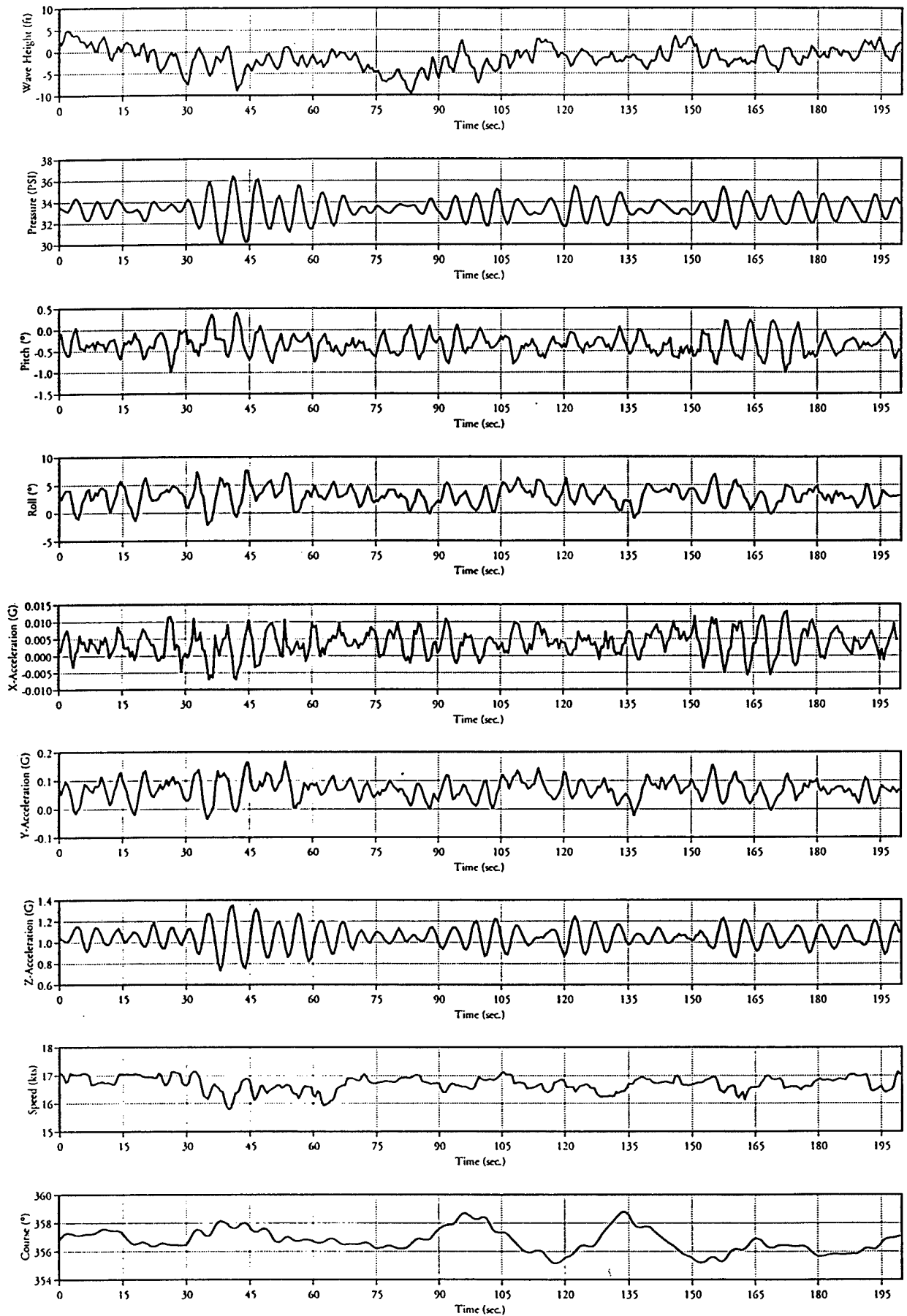

# RF22a Environmental Data

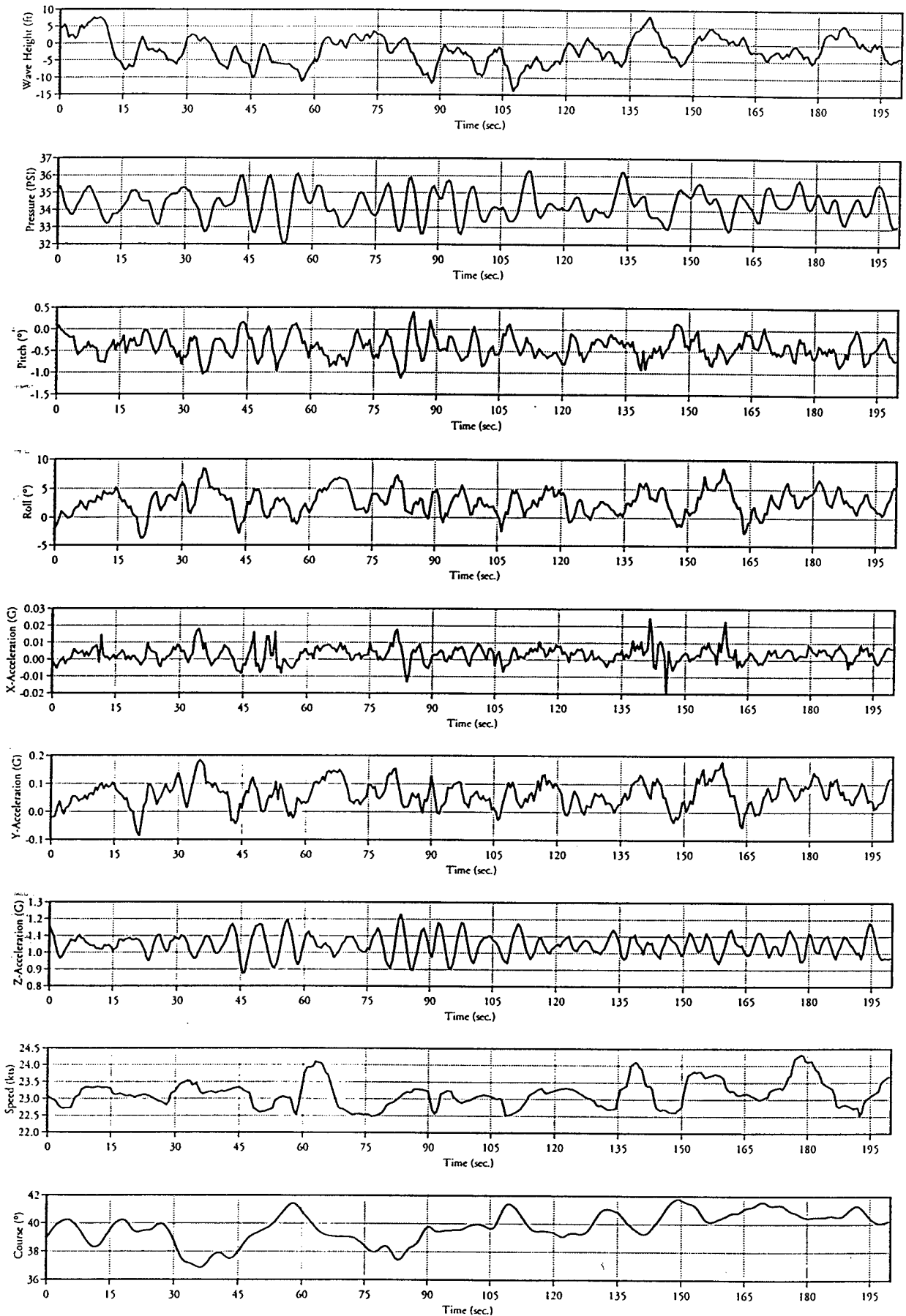

# RF22b Environmental Data

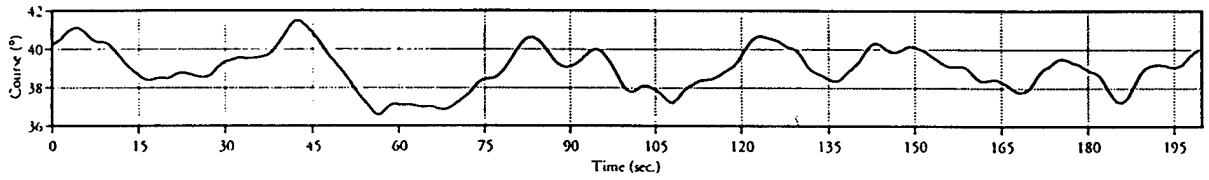
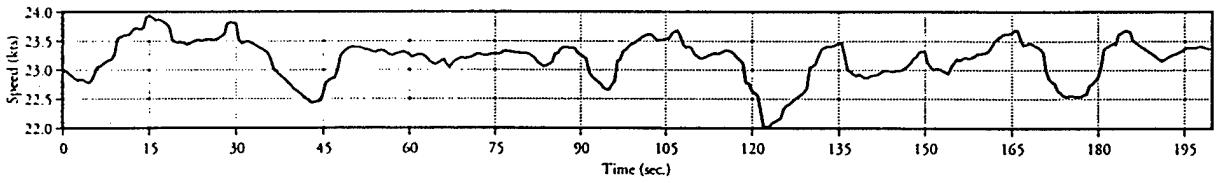
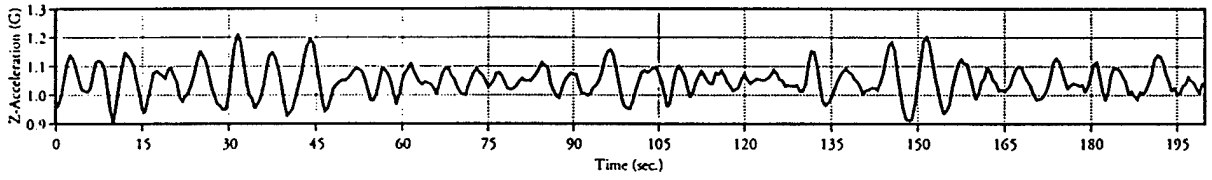
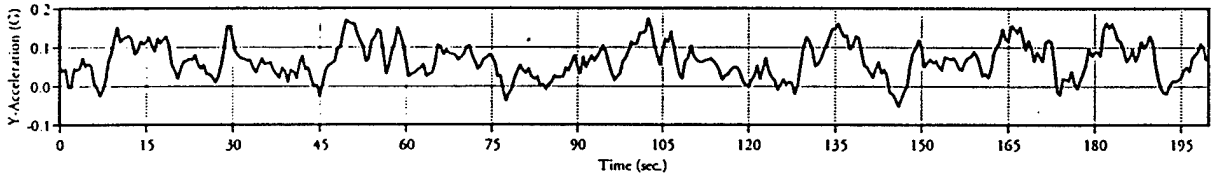
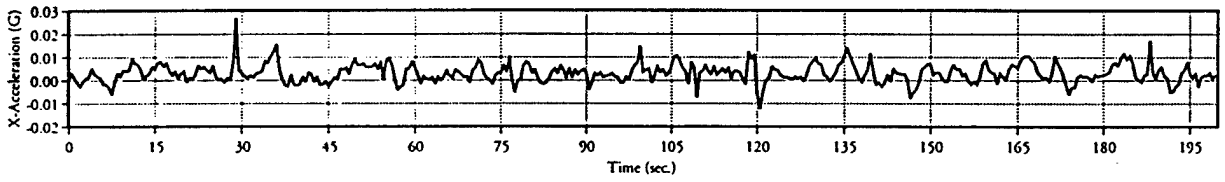
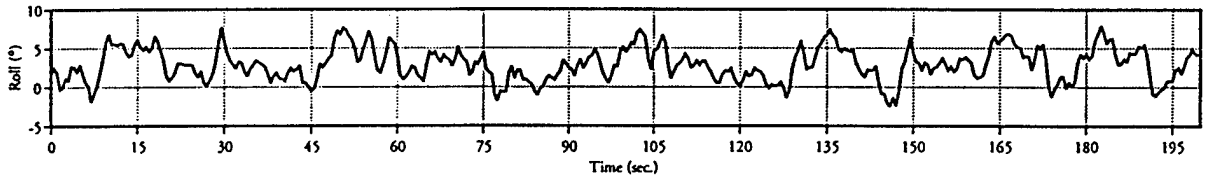
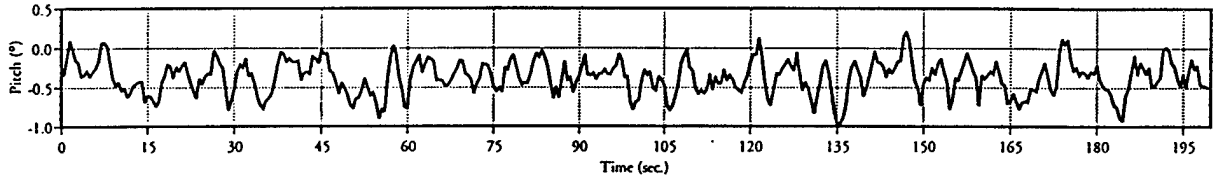
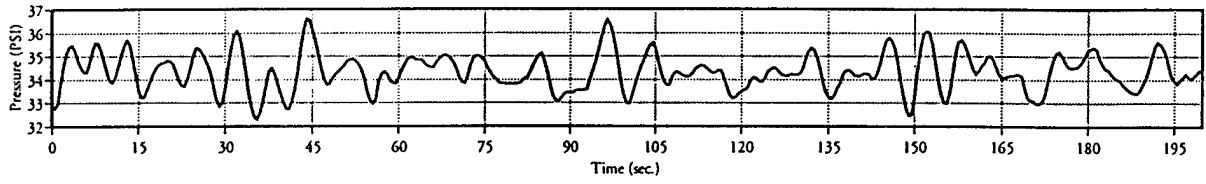
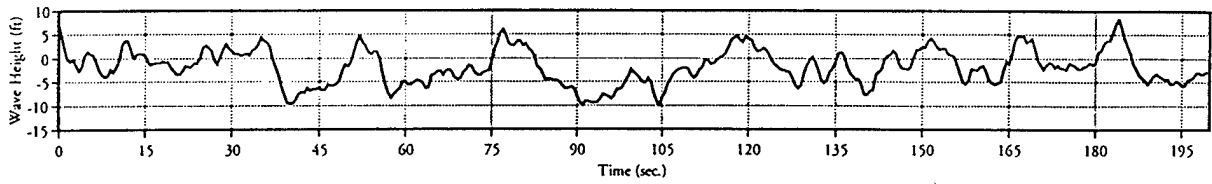

# rg10a Environmental Data

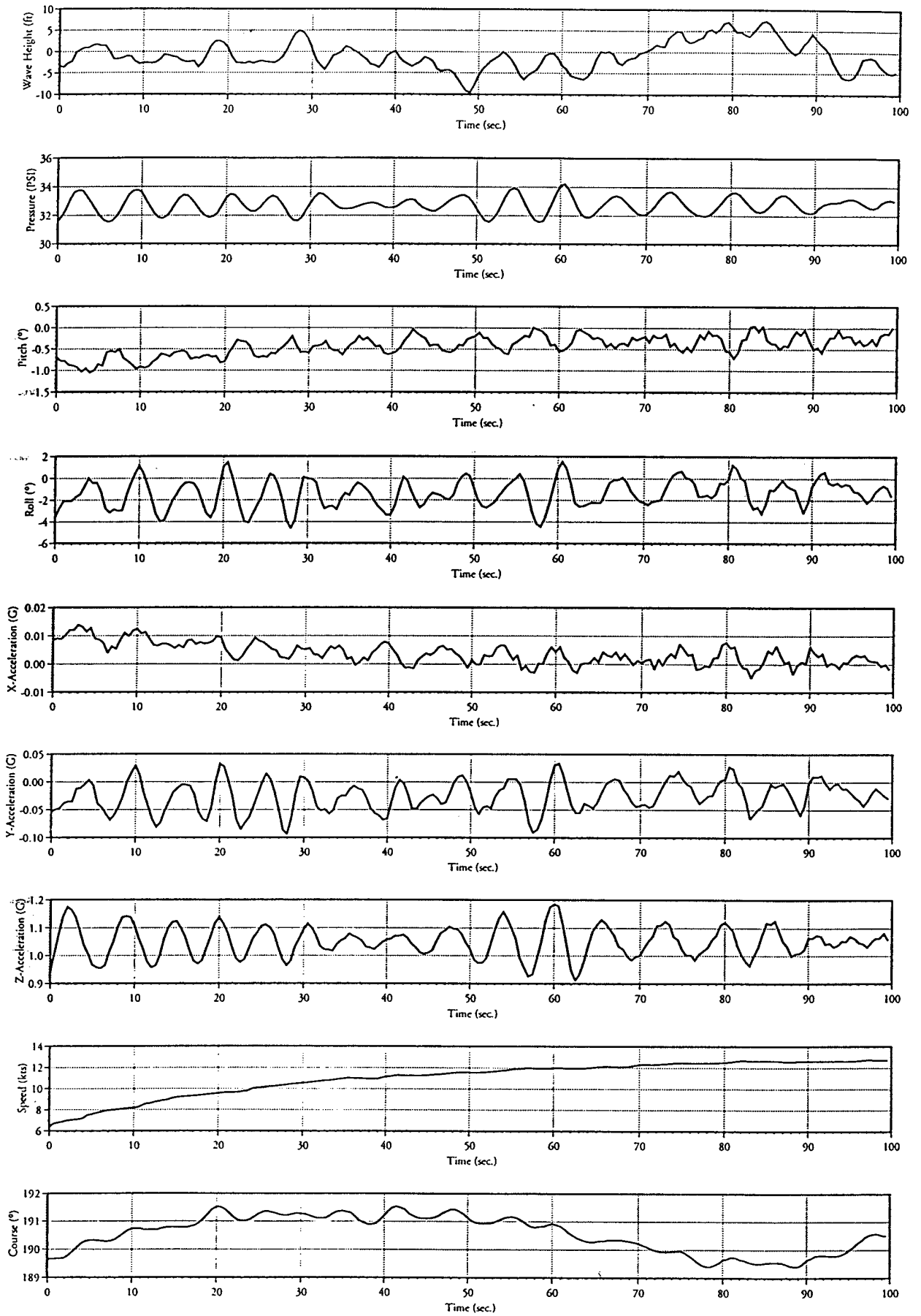

# rg13a Environmental Data

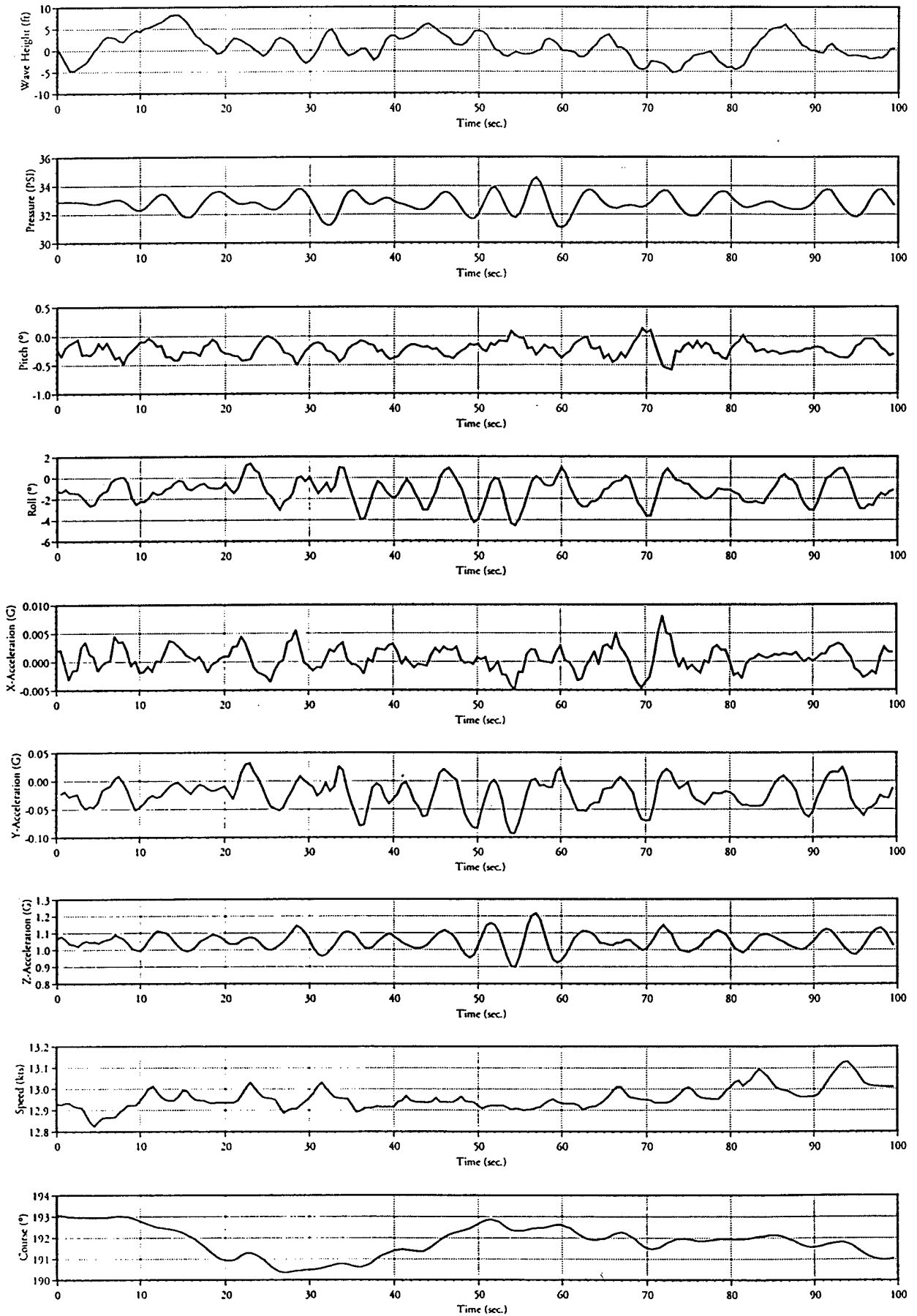



# rg5a Environmental Data

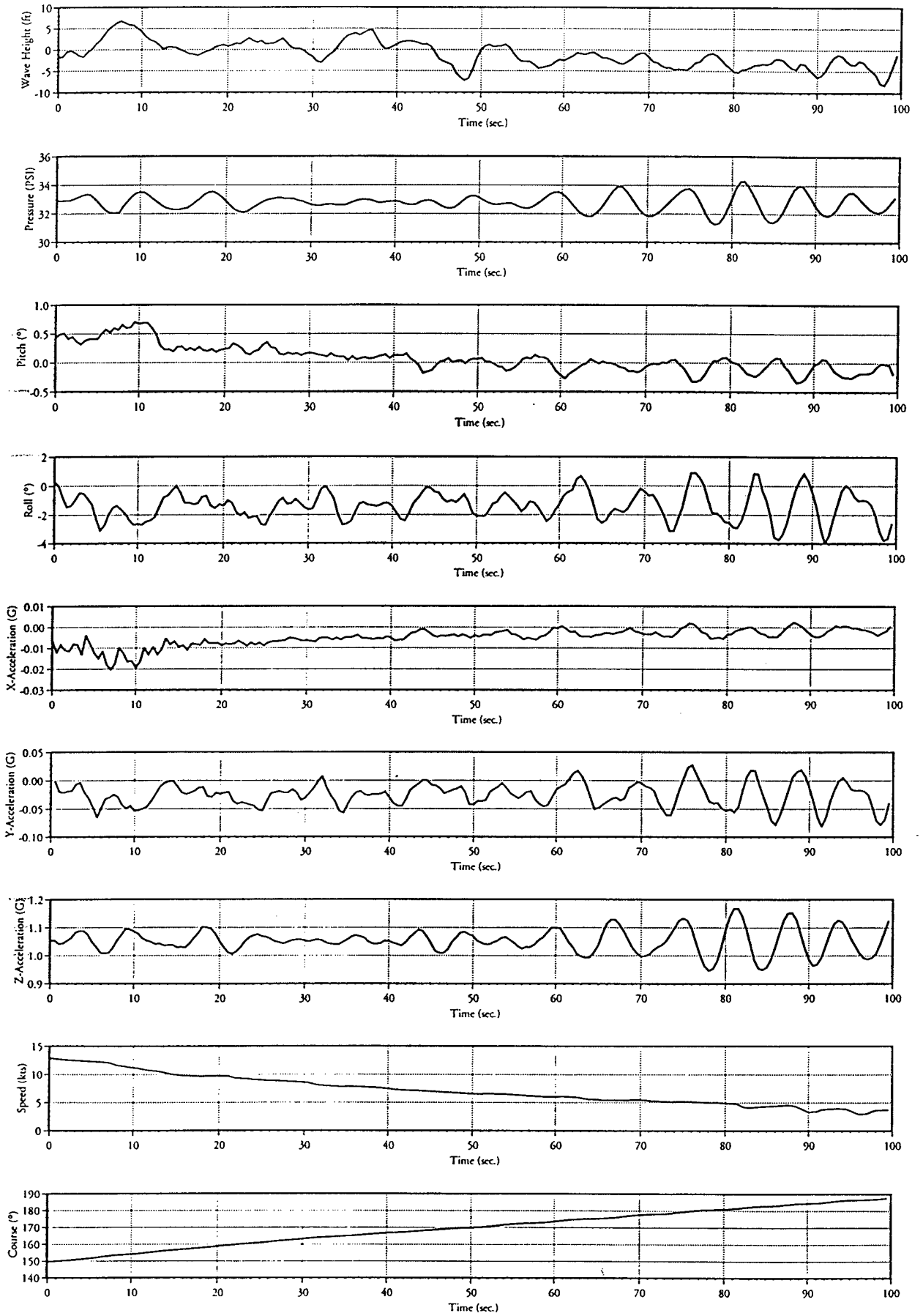

# rg5b Environmental Data

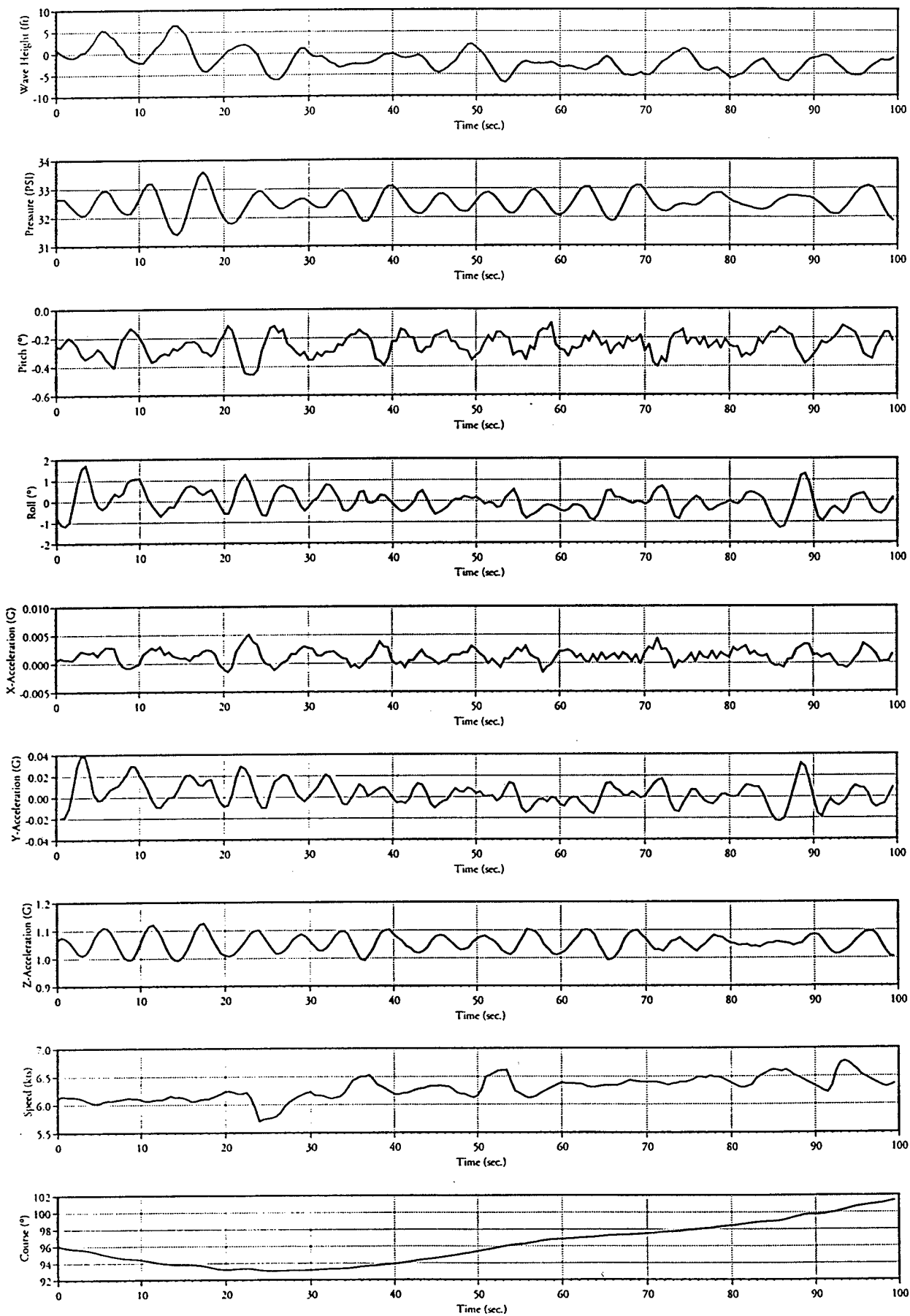

# rg6a Environmental Data

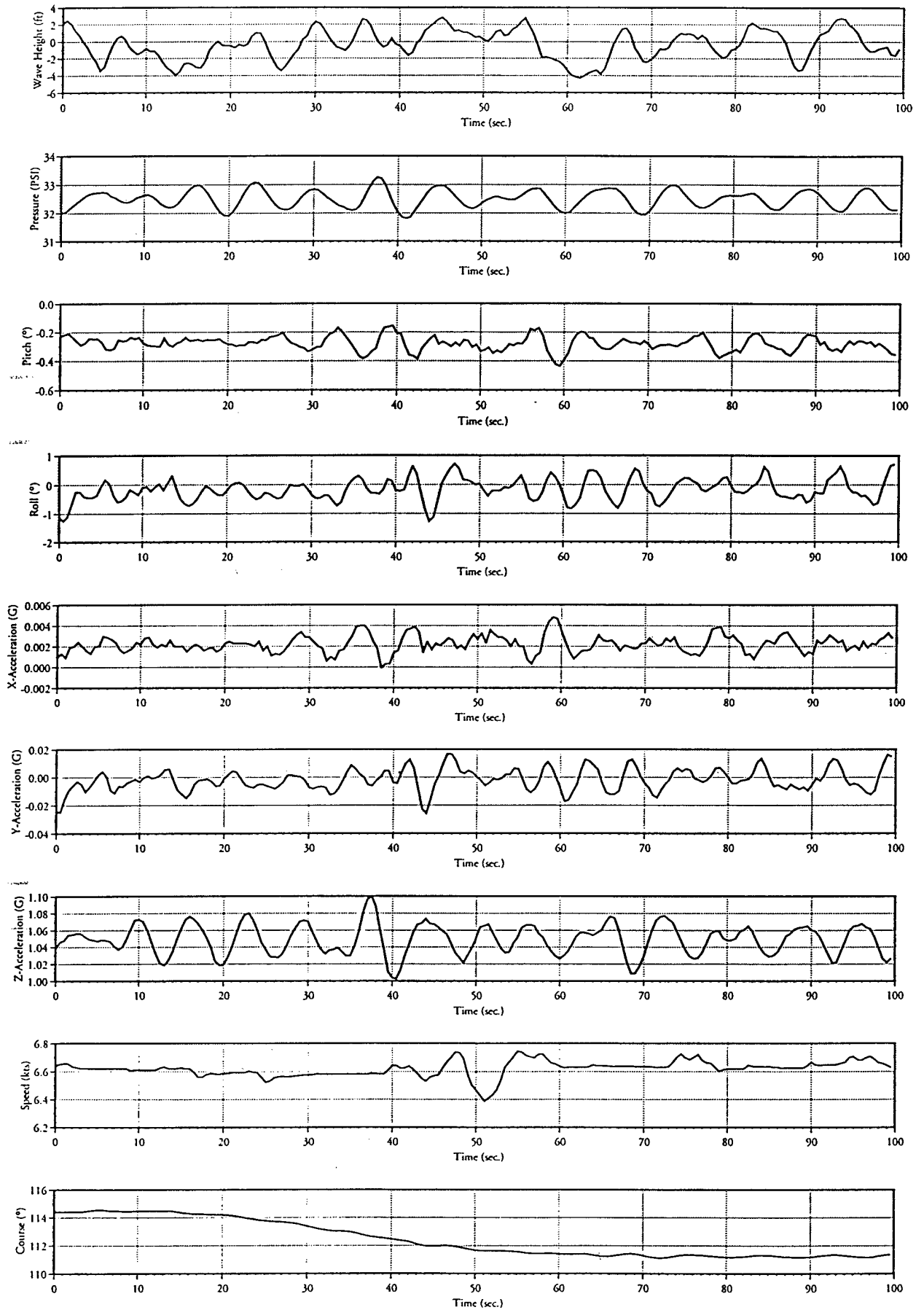

# RH4a Environmental Data

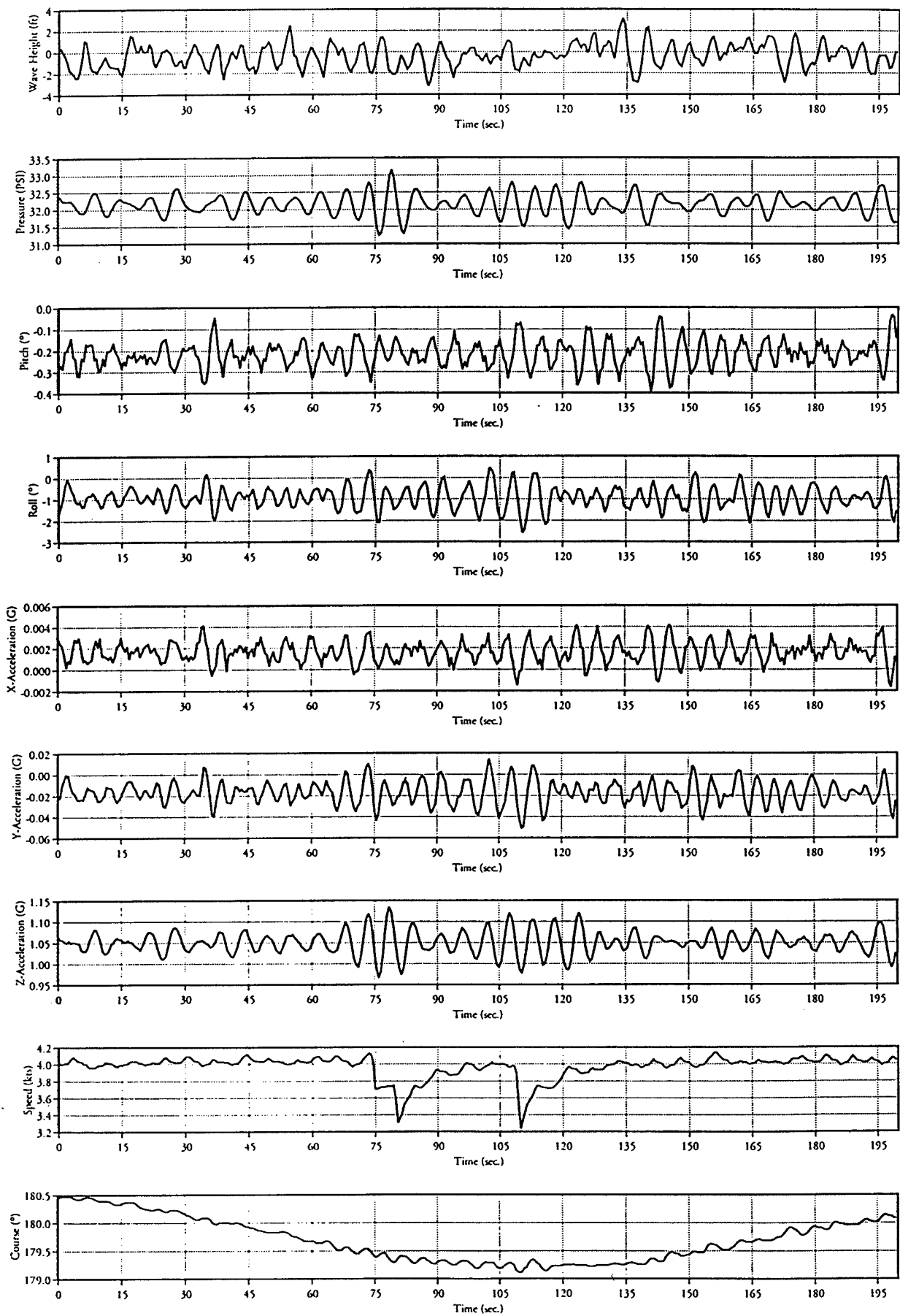

# RH8a Environmental Data

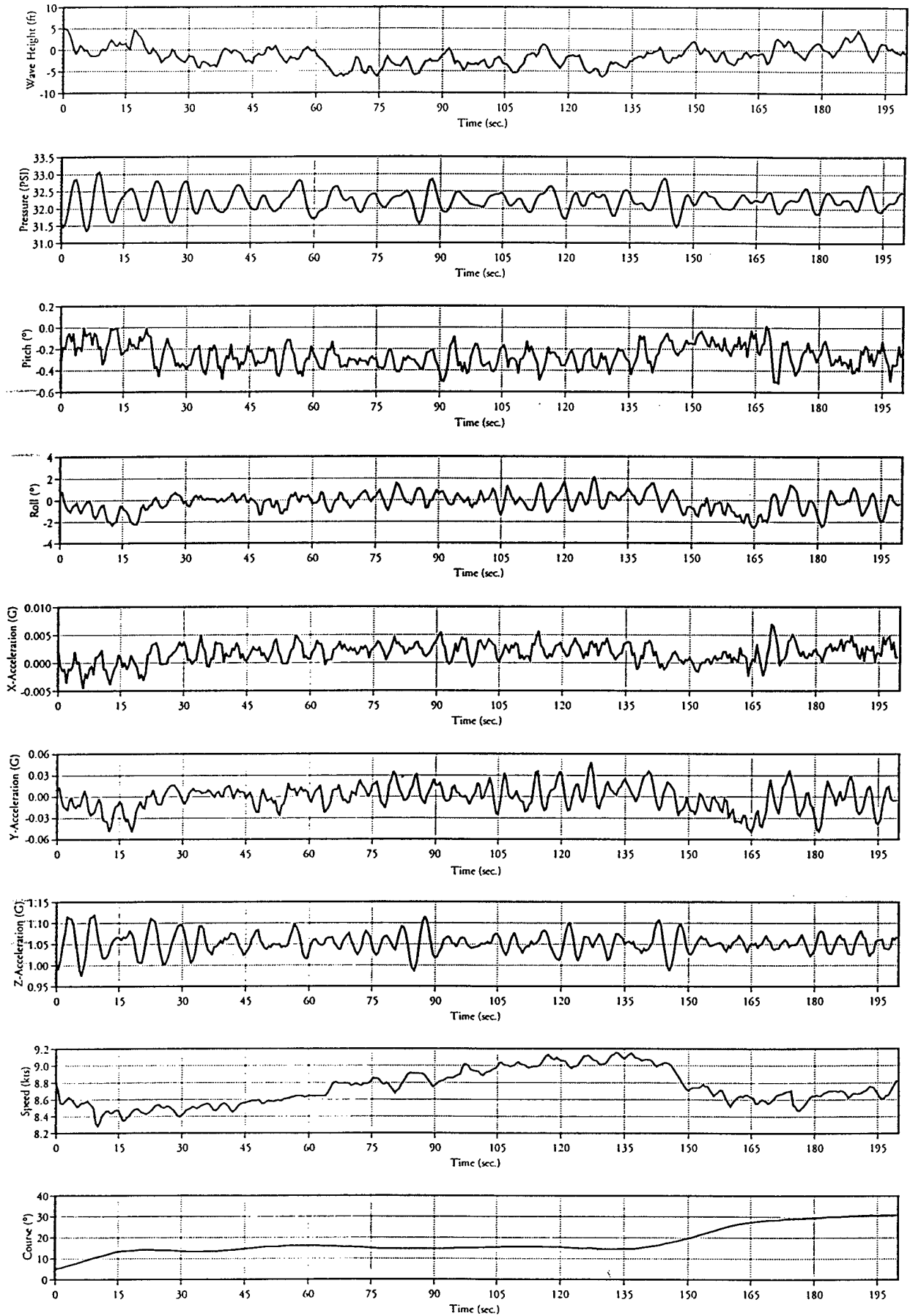

RL03a Environmental Data

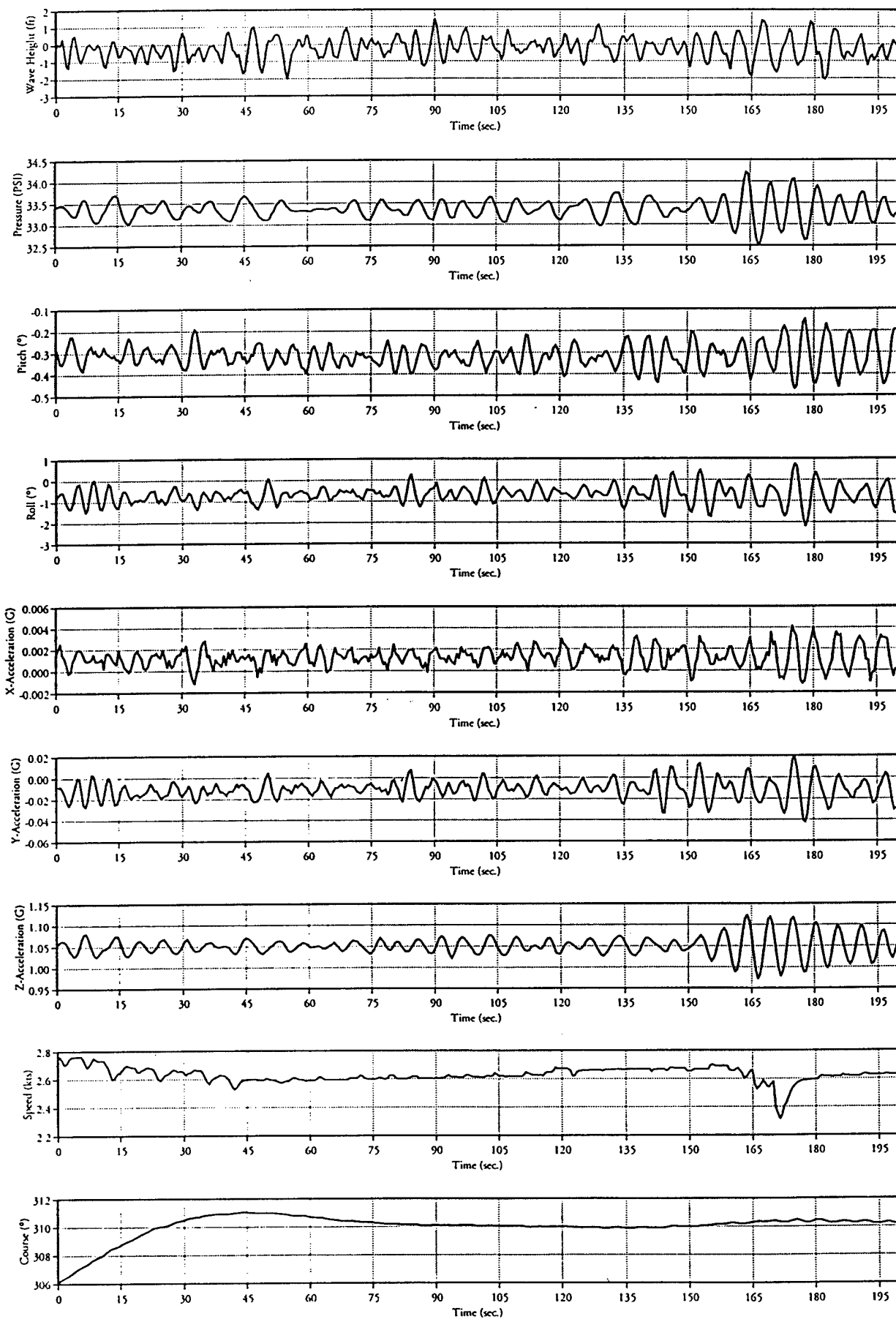

# RL09a Environmental Data

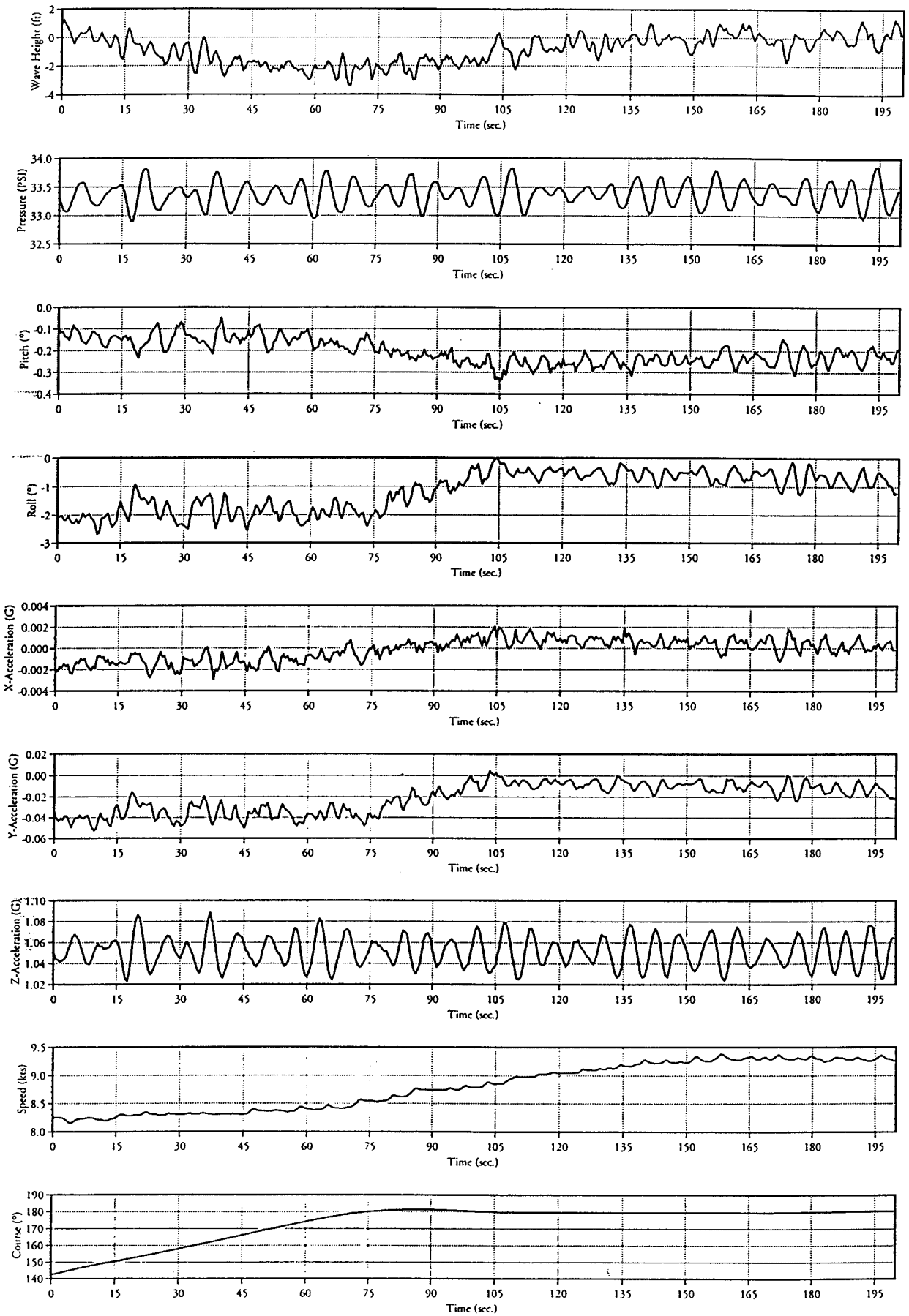

# RL11a Environmental Data

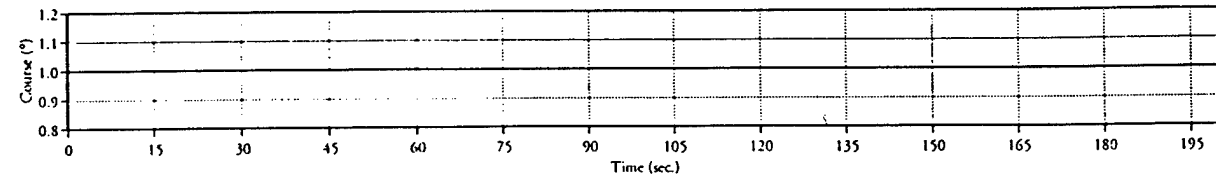
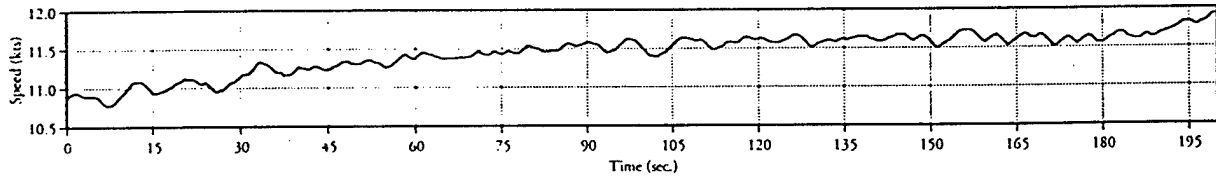
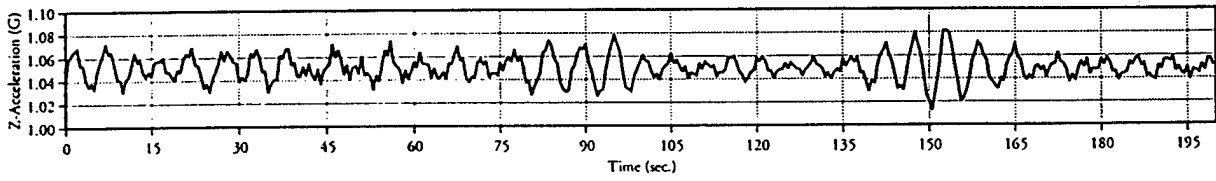
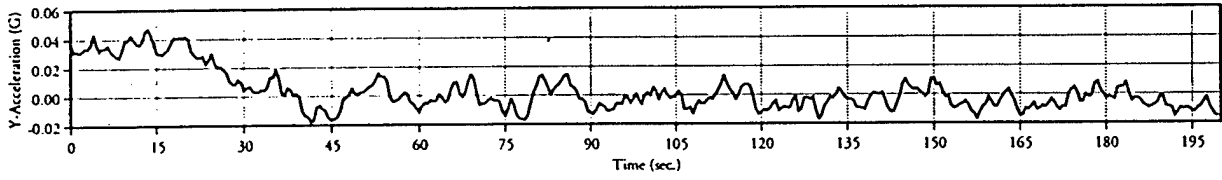
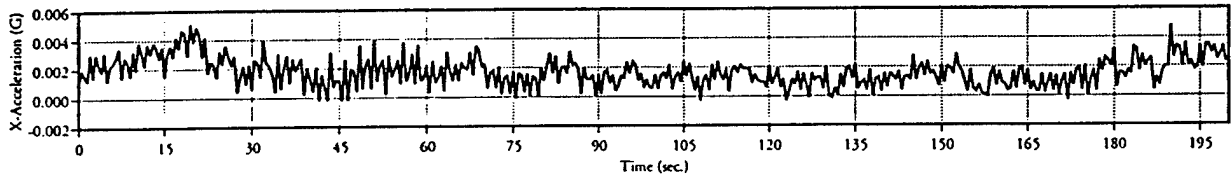
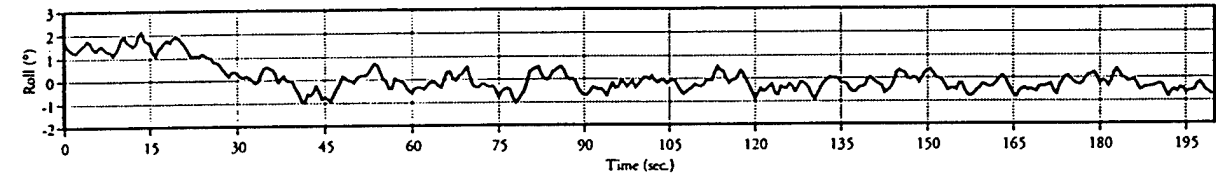
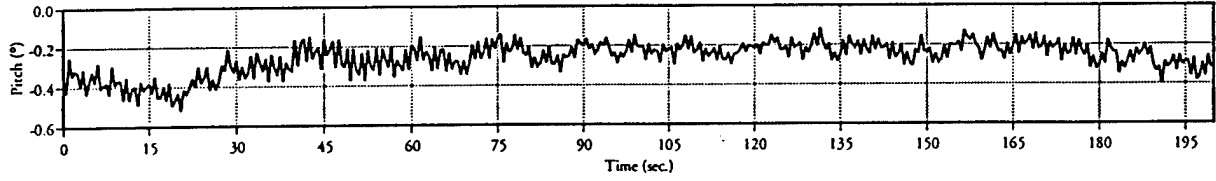
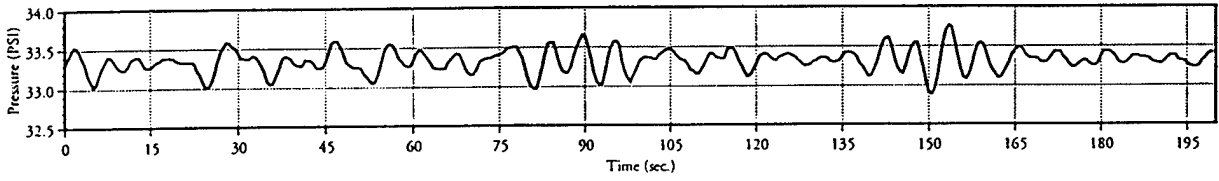
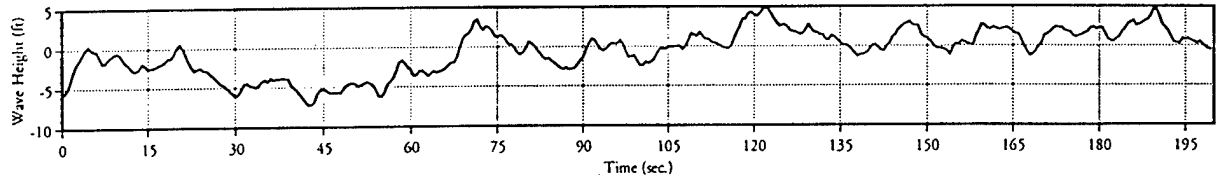



# RL13a Environmental Data

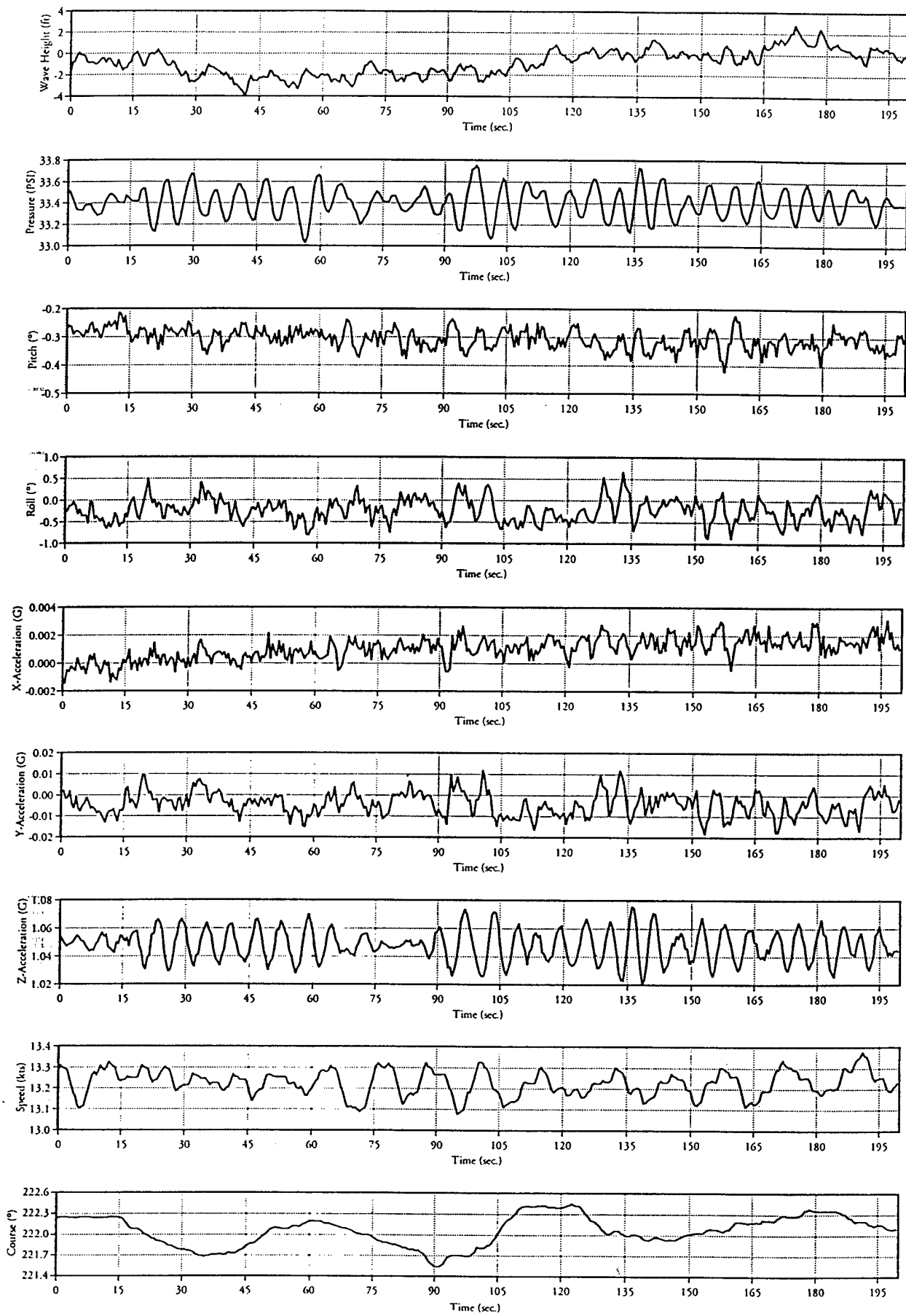

# RL13b Environmental Data

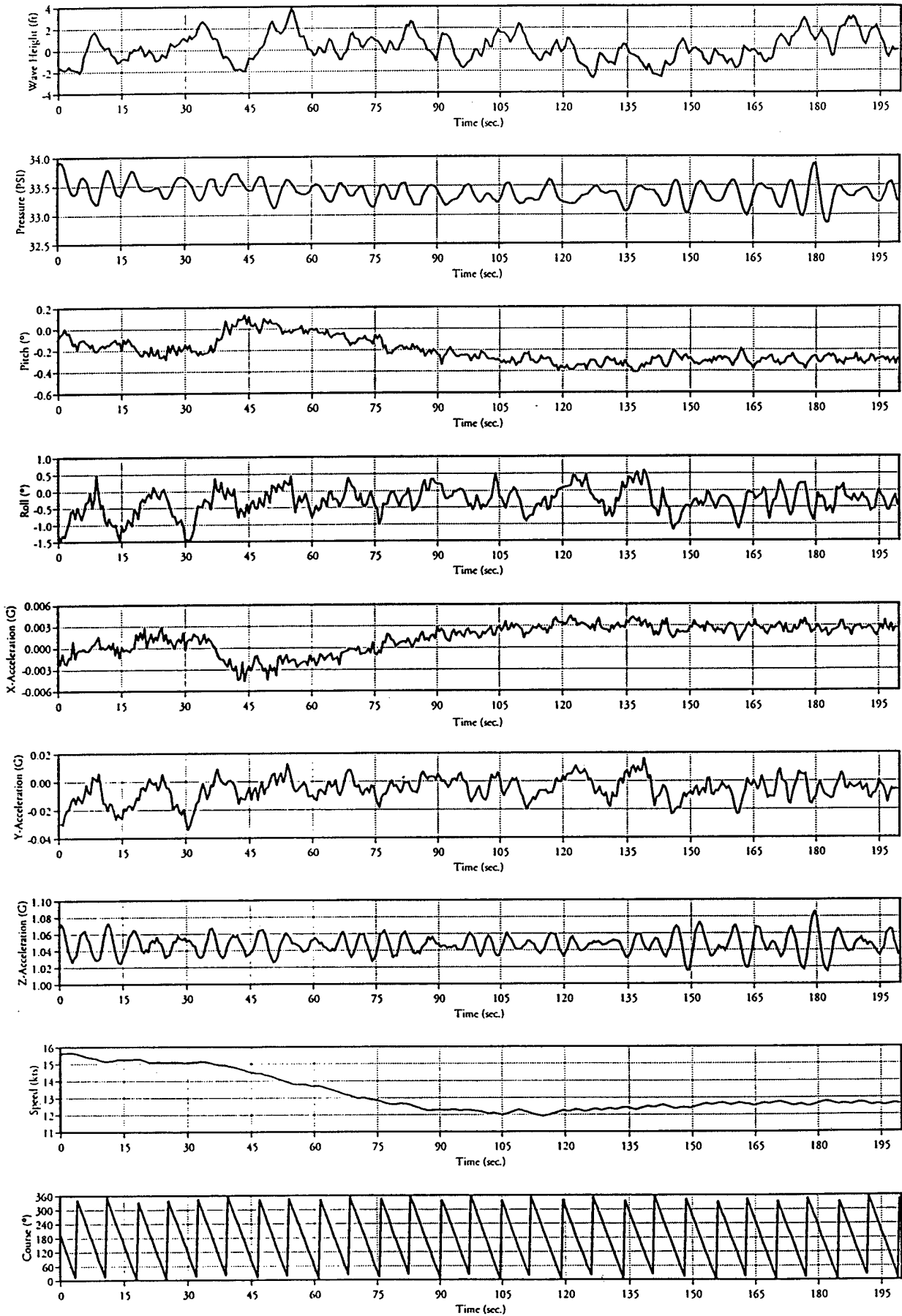

# RL13c Environmental Data

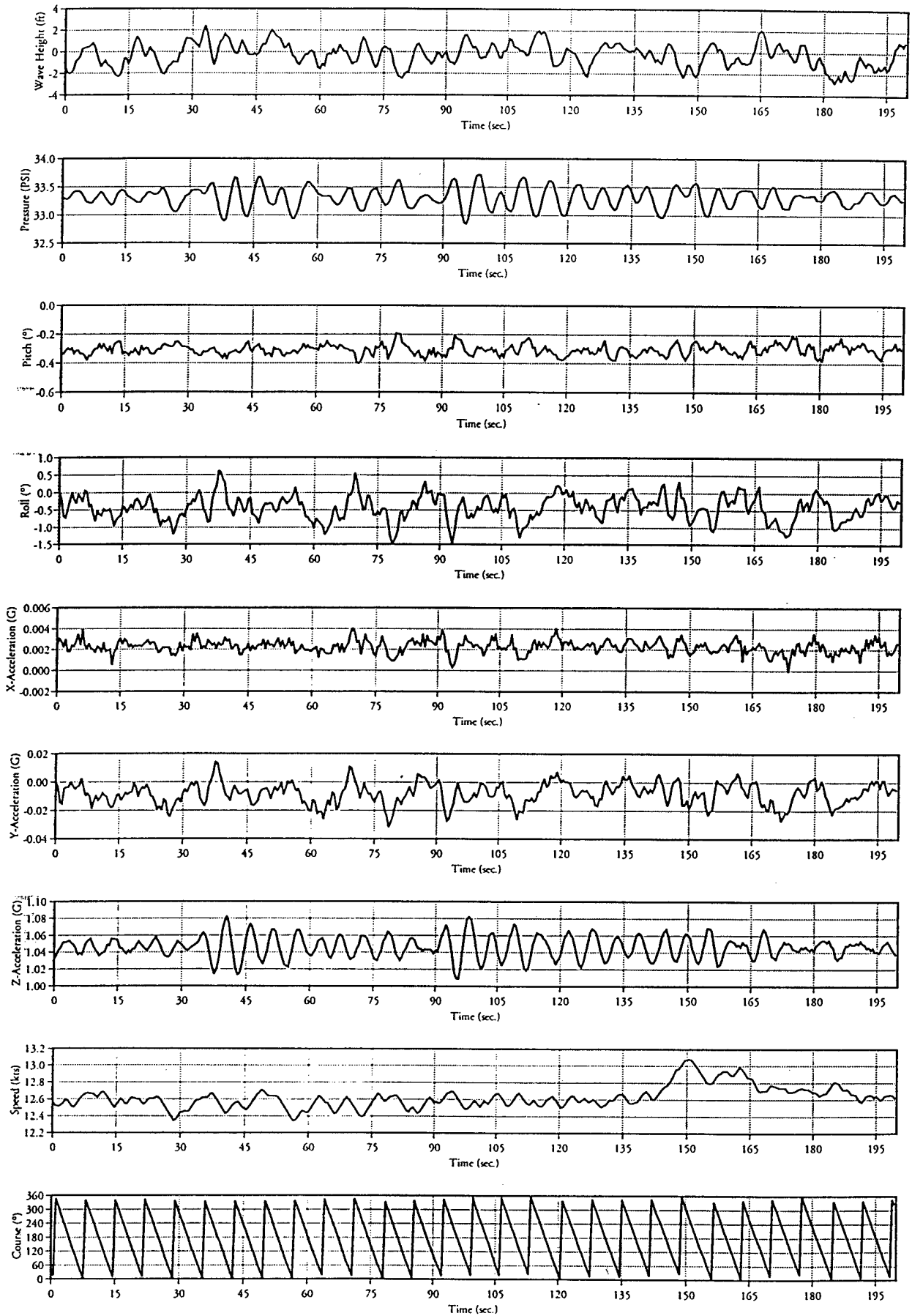

# RL14a Environmental Data

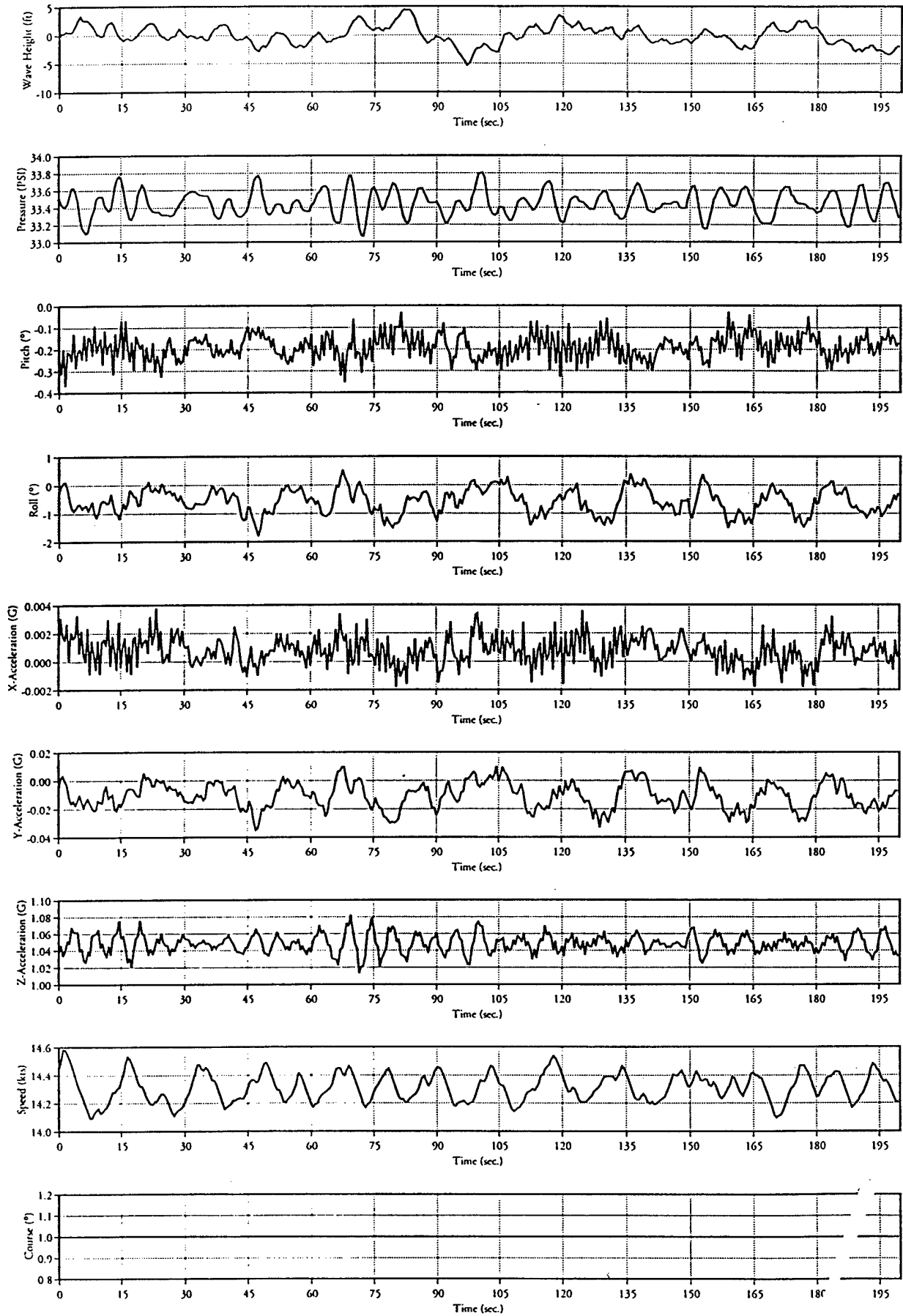

# RL14b Environmental Data

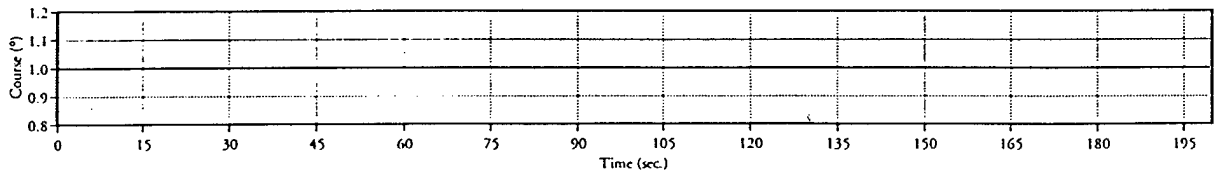
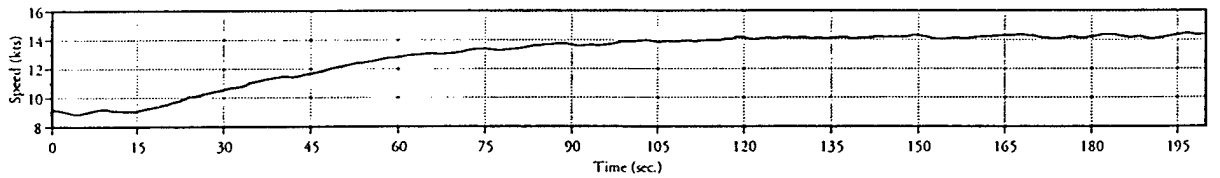
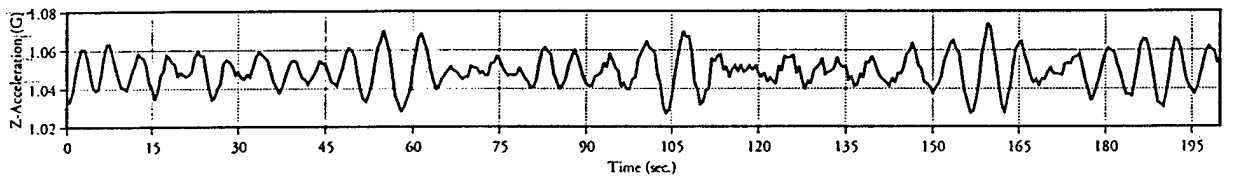
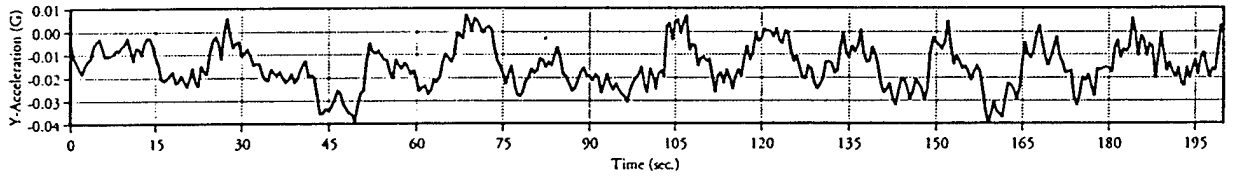
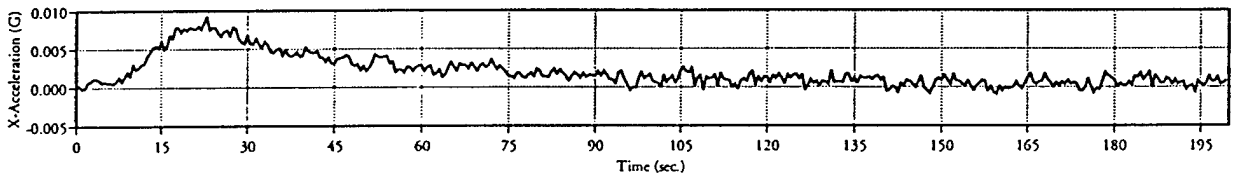
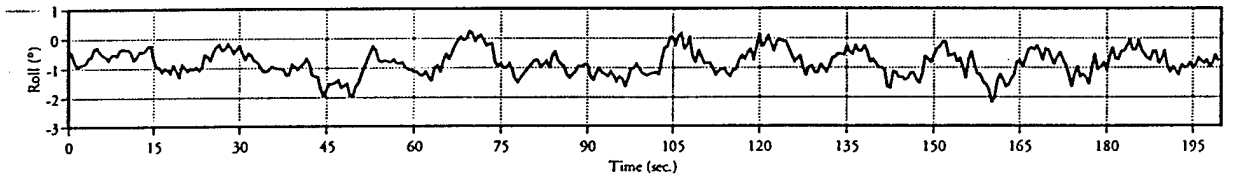
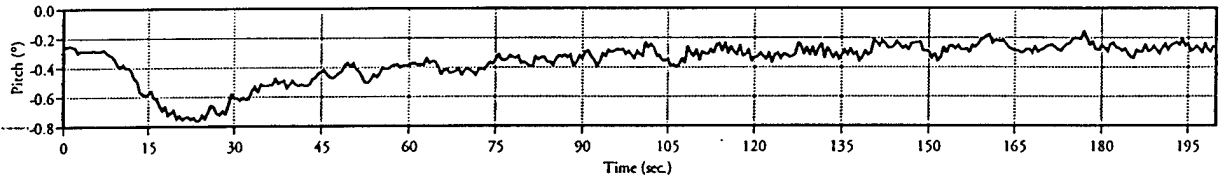
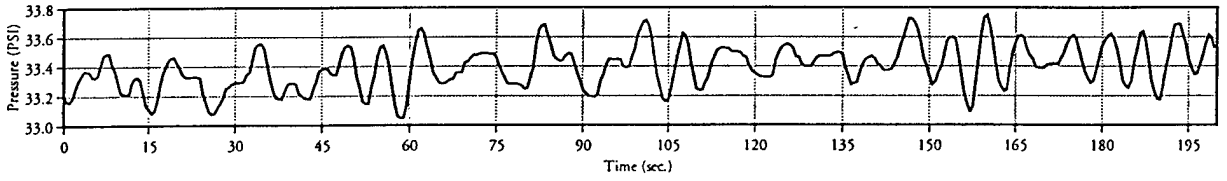
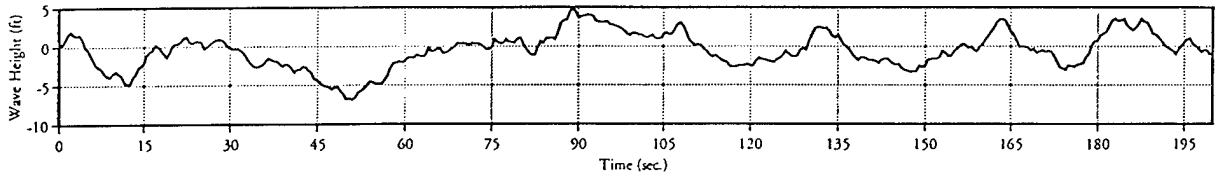

# RL15a Environmental Data

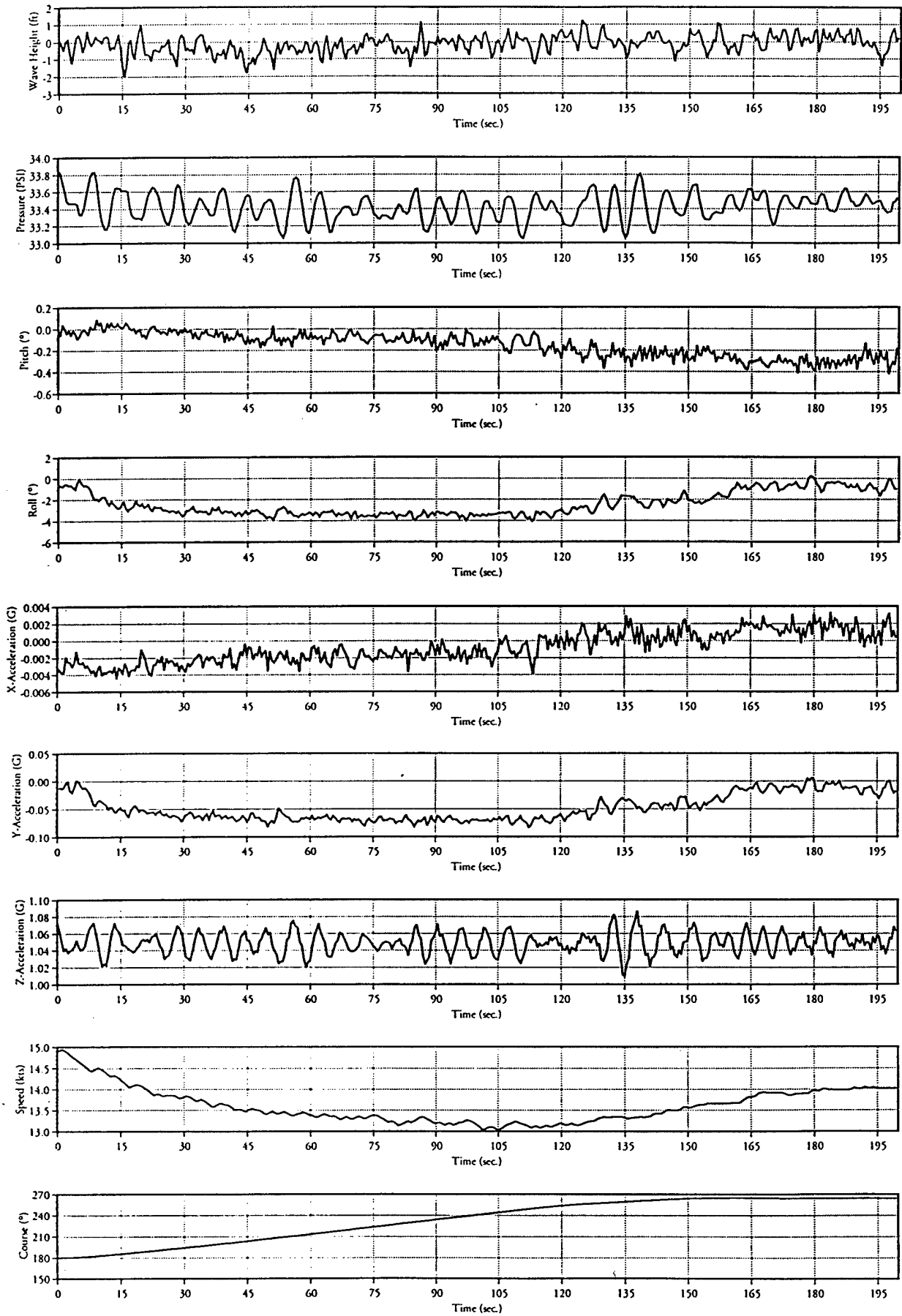

# RL17a Environmental Data

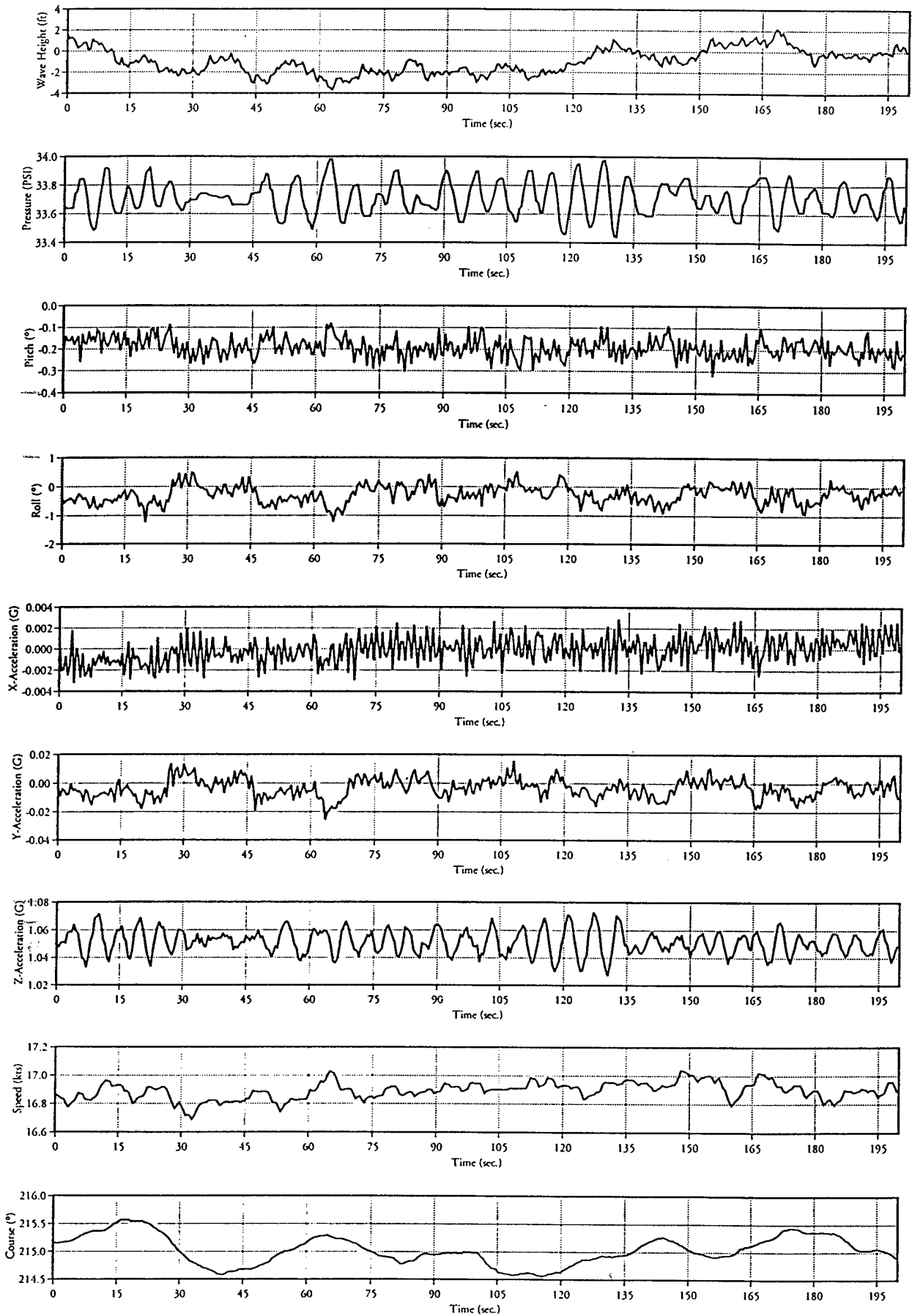

# RL21a Environmental Data

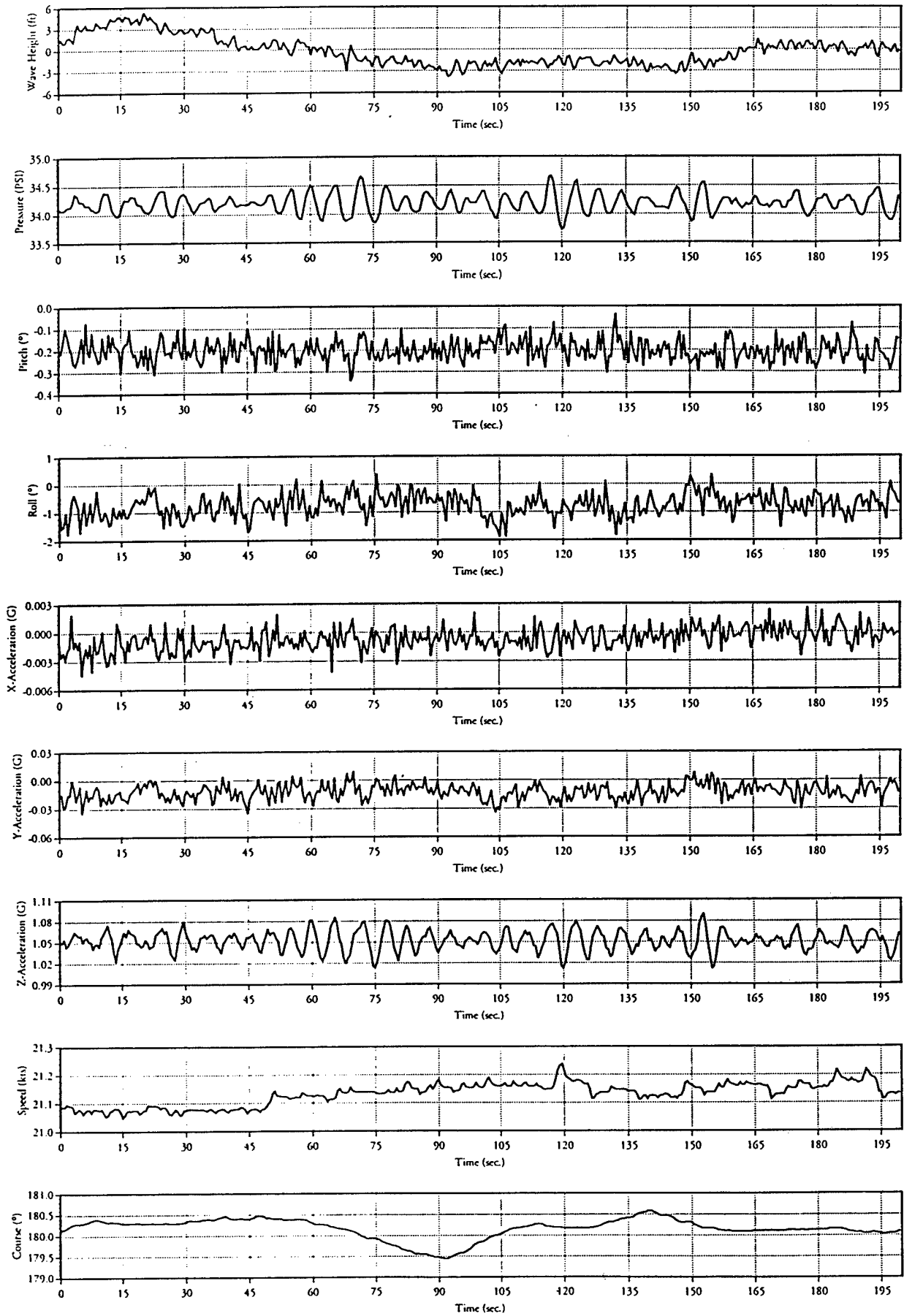



# RL21b Environmental Data

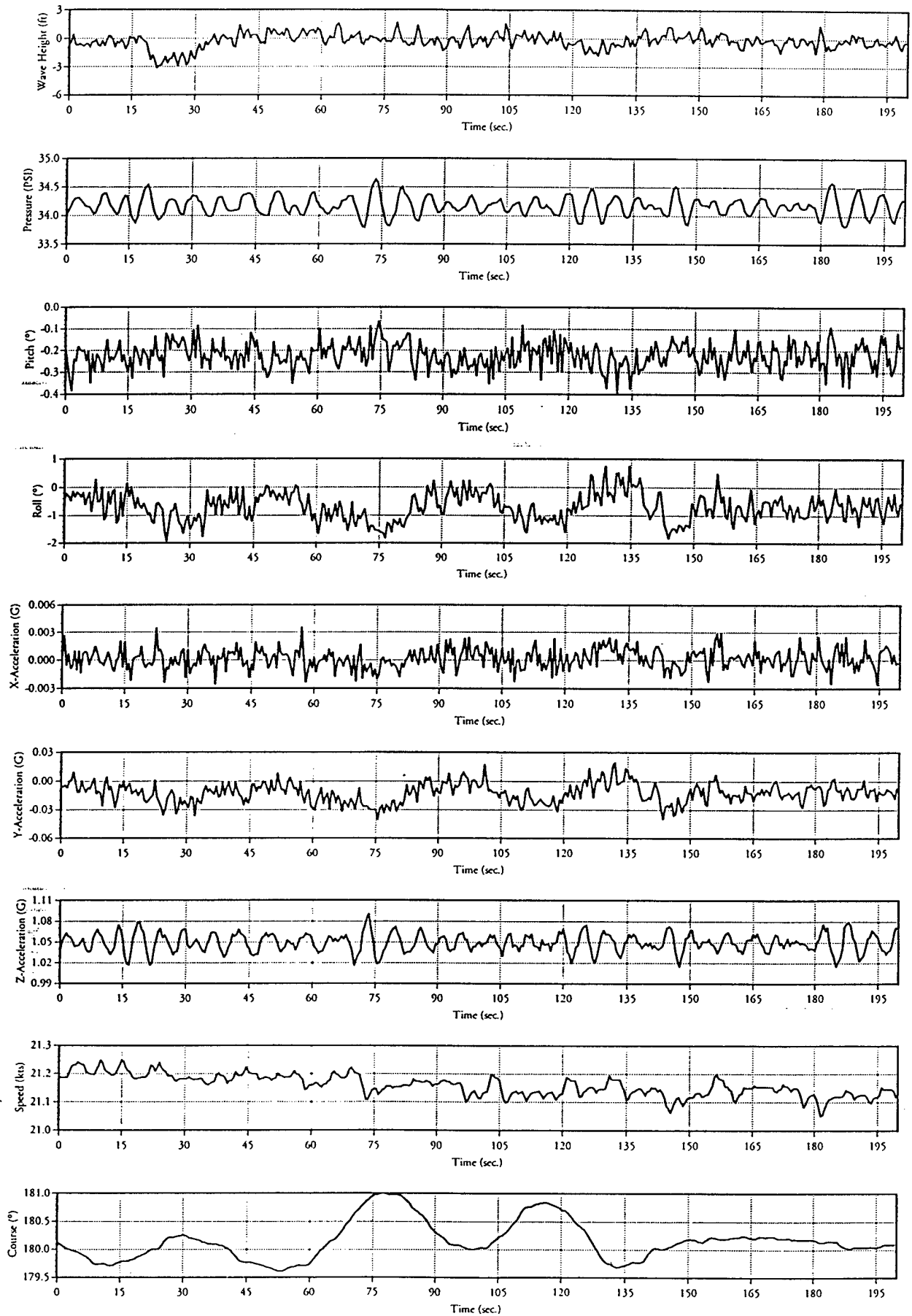

# RL21c Environmental Data

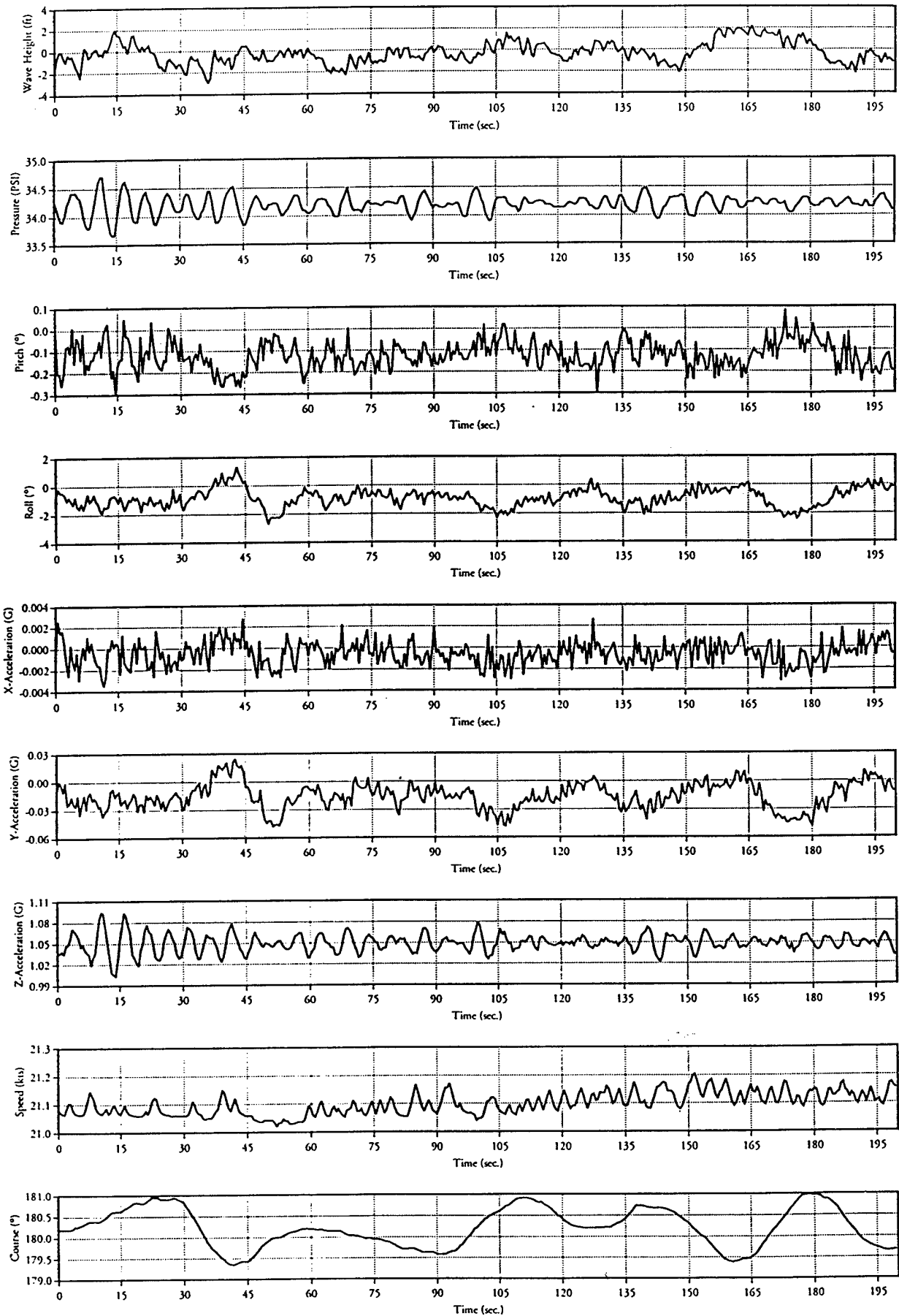

# RL21c Environmental Data

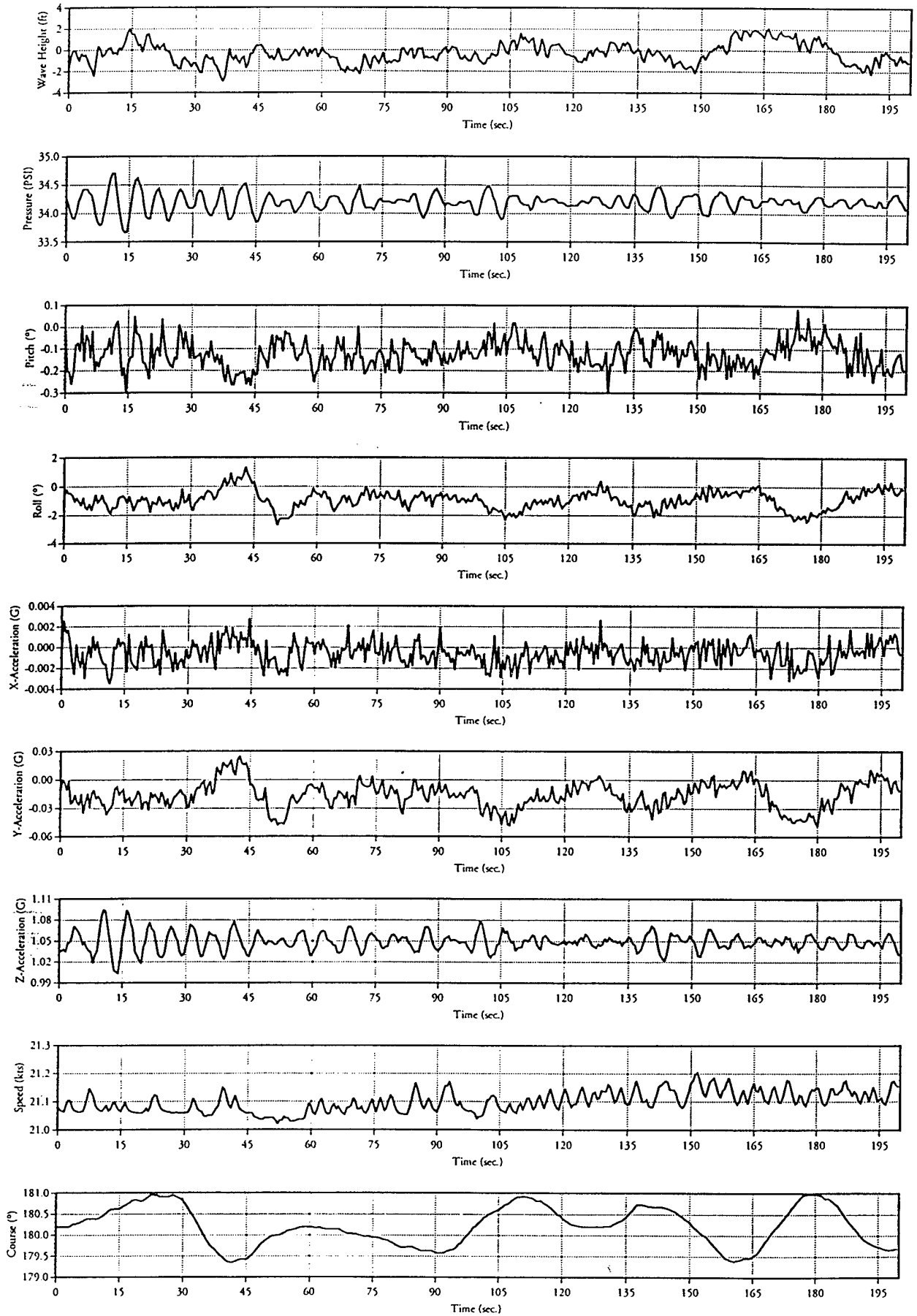

# RL21d Environmental Data

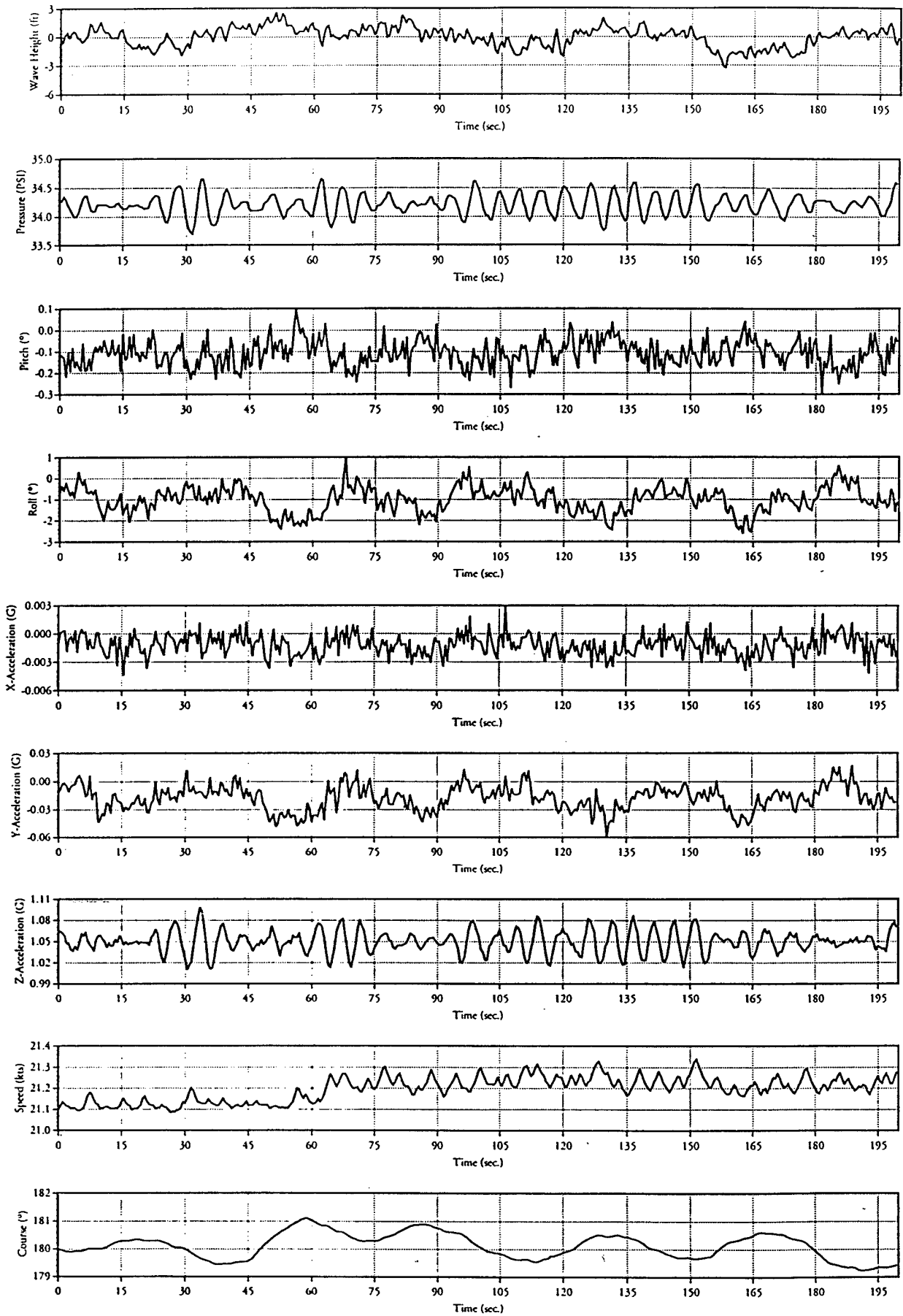

# RL23a Environmental Data

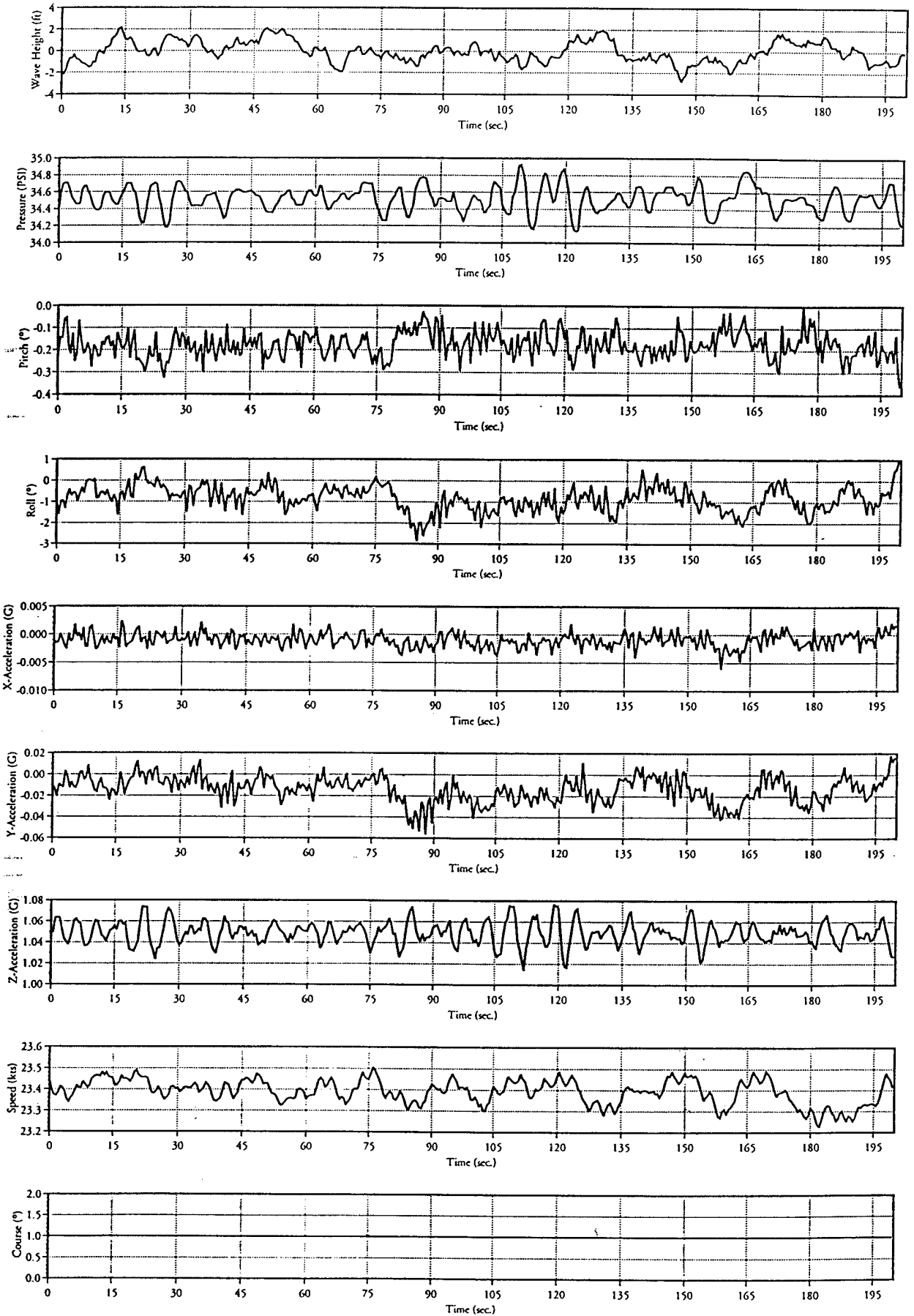

# RL23b Environmental Data

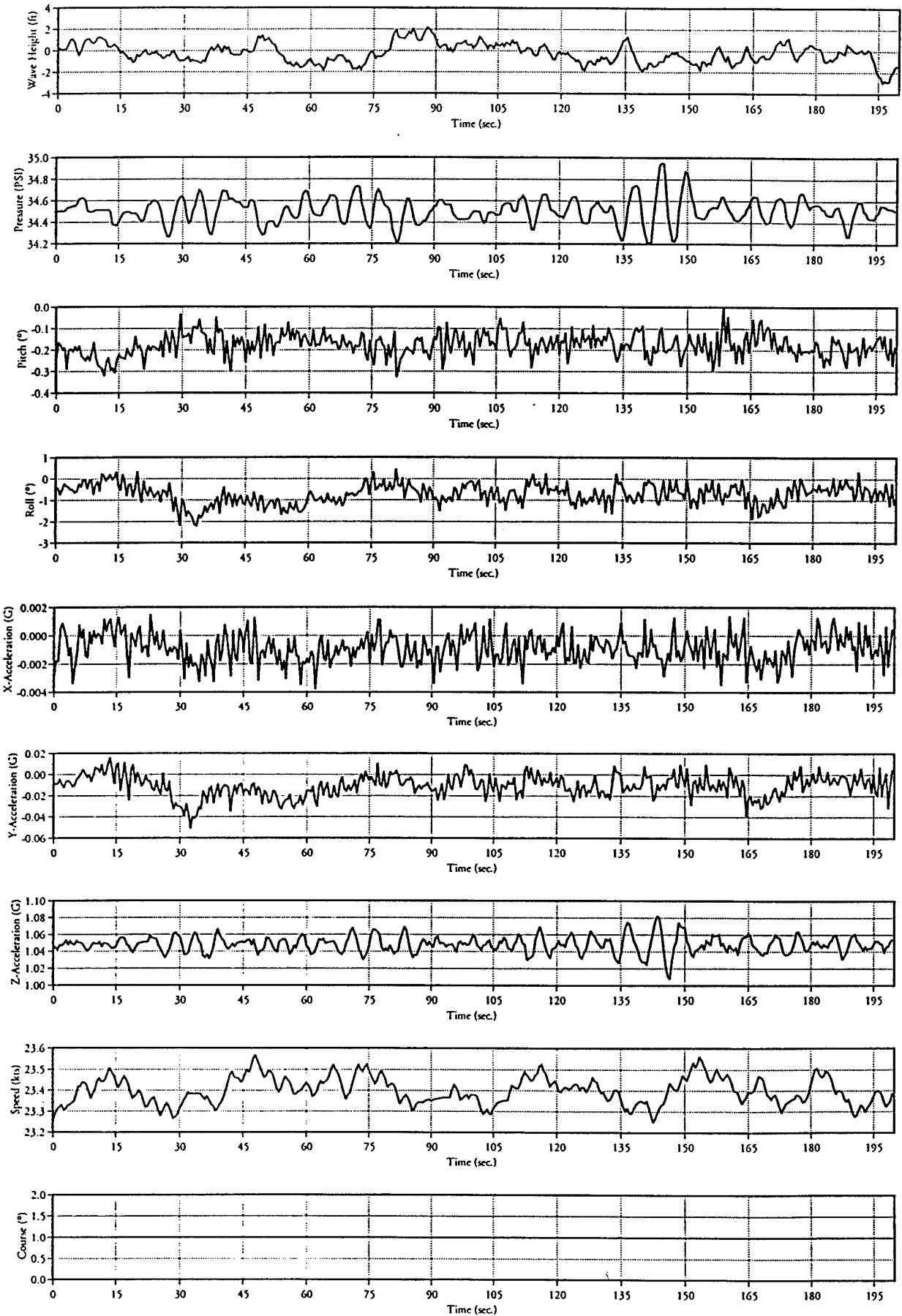

# RL25a Environmental Data

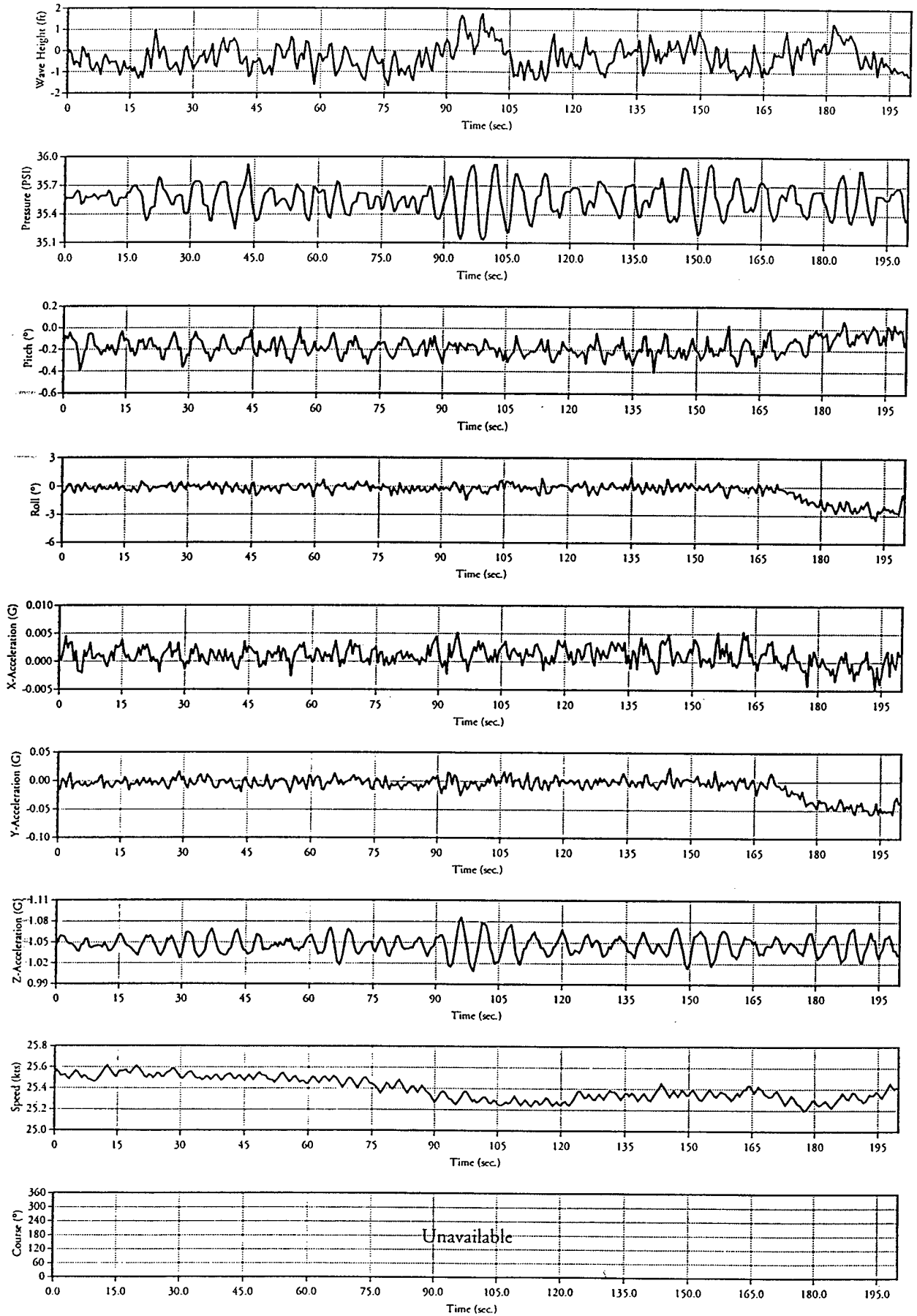

# RL26a Environmental Data

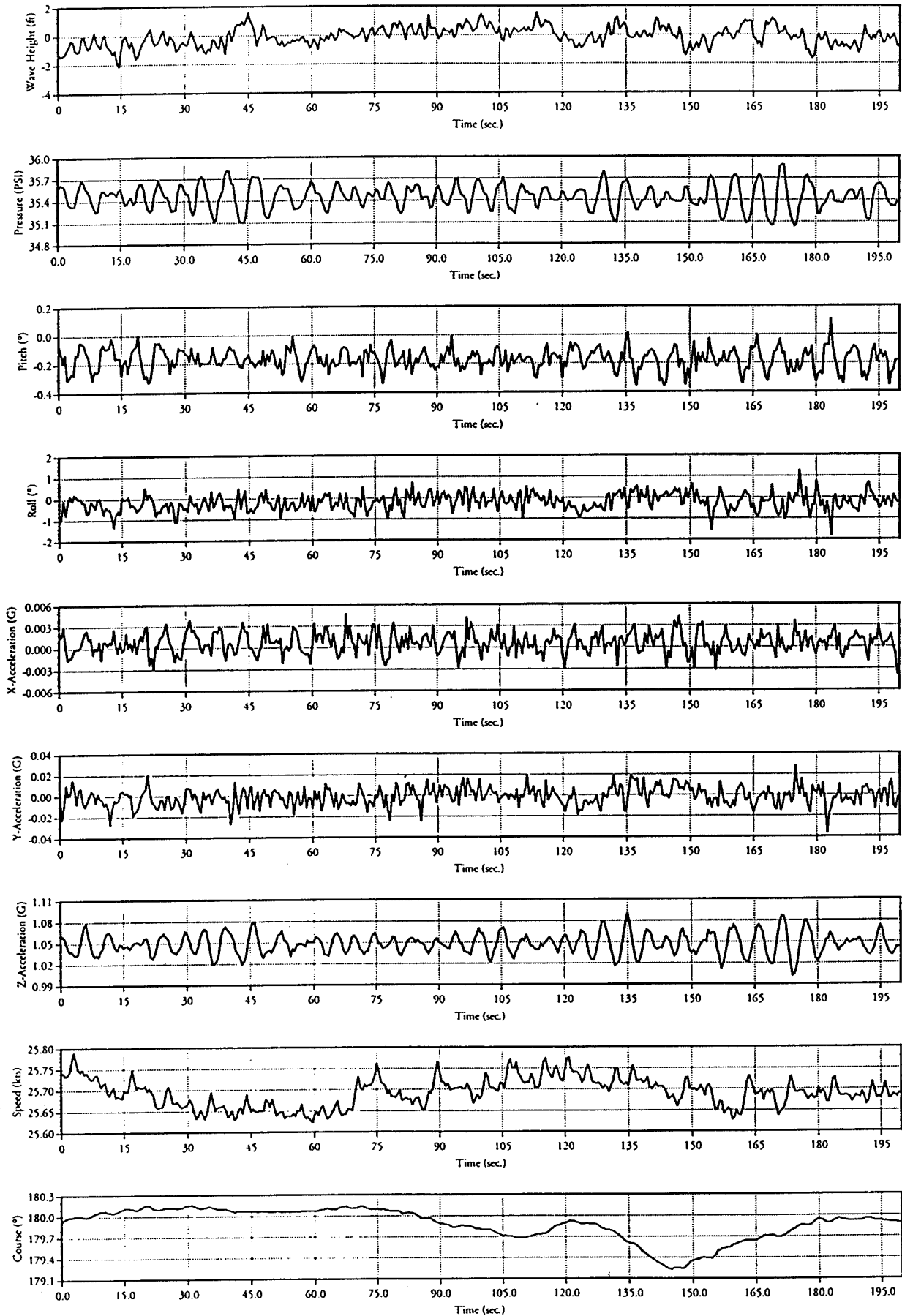



# RL26b Environmental Data

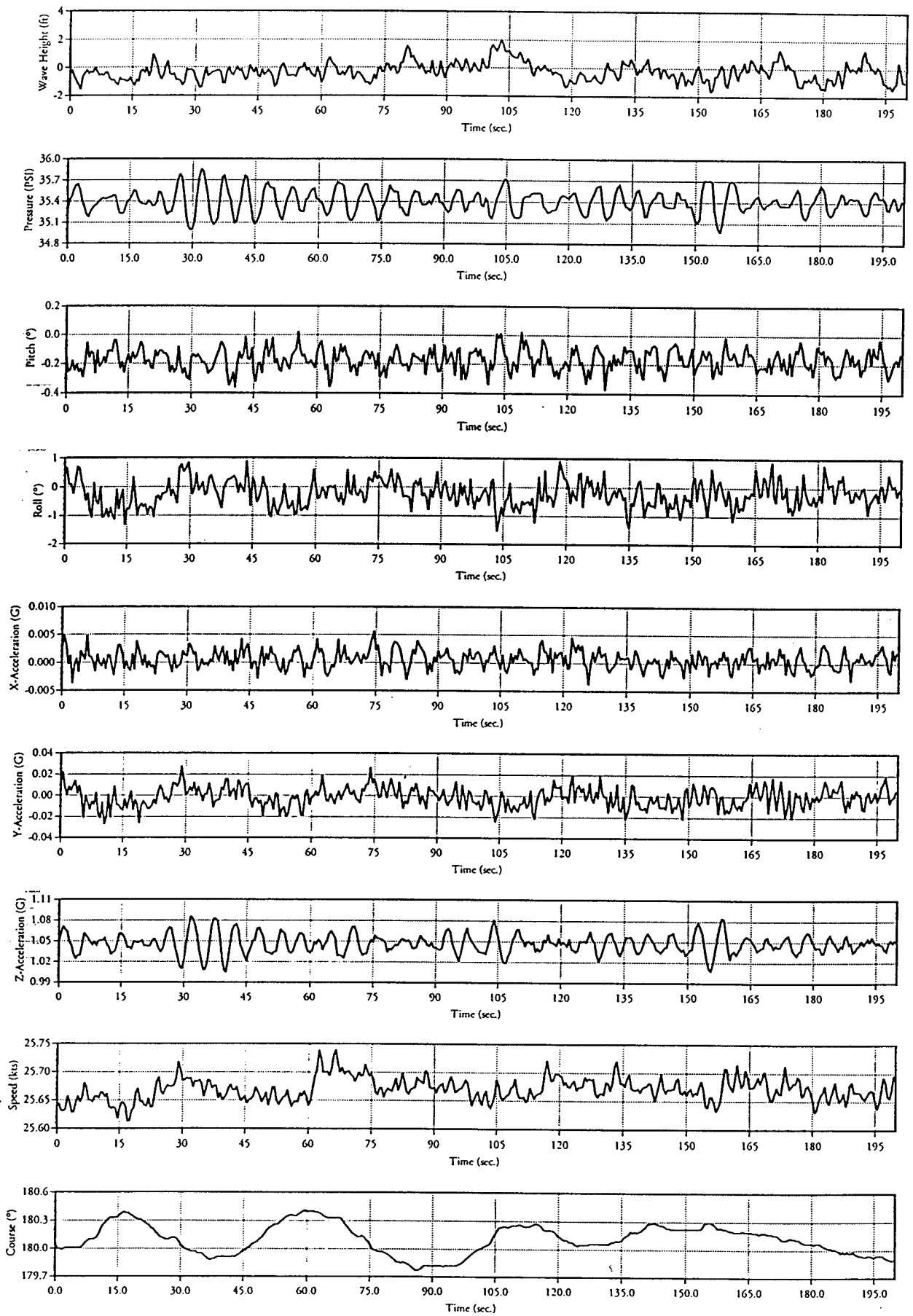

# RL28a Environmental Data

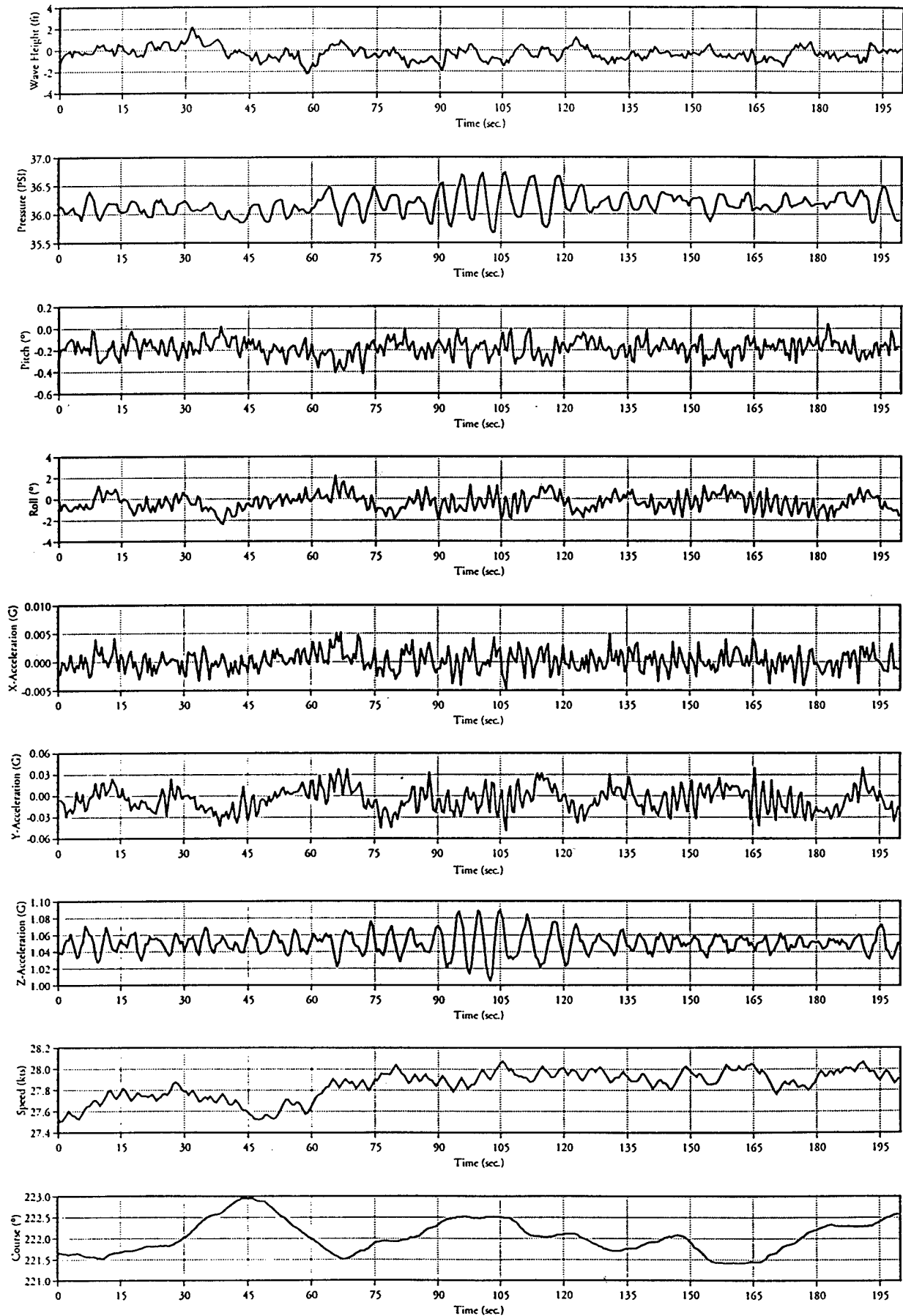

# RLm28a Environmental Data

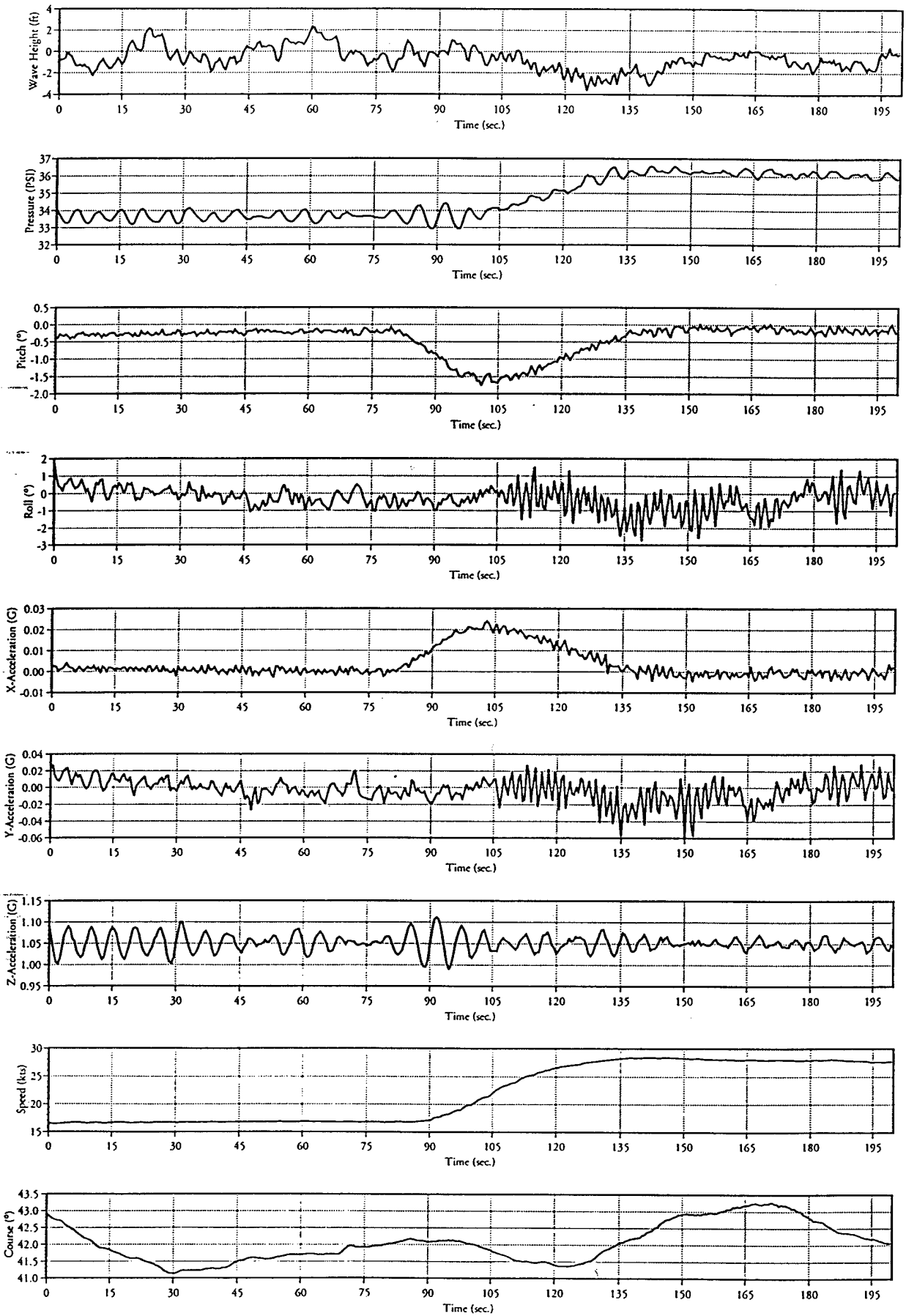

# RM15A Environmental Data

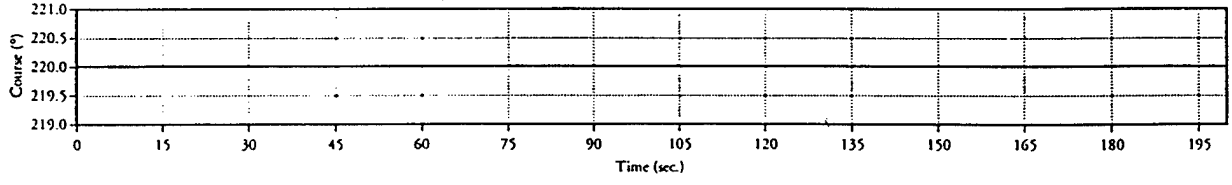
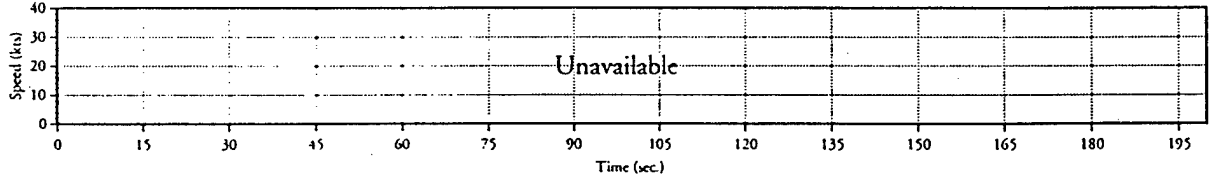
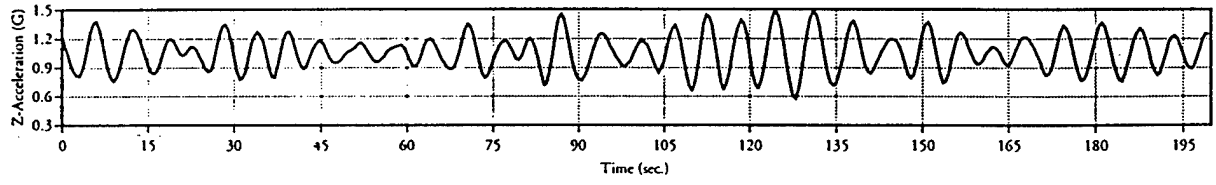
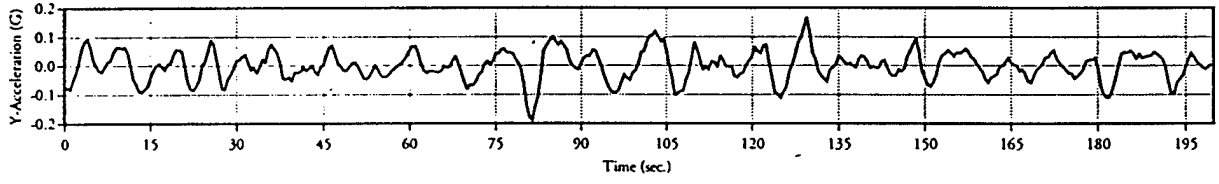
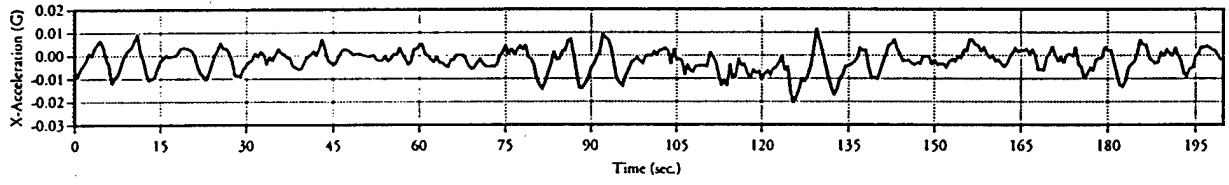
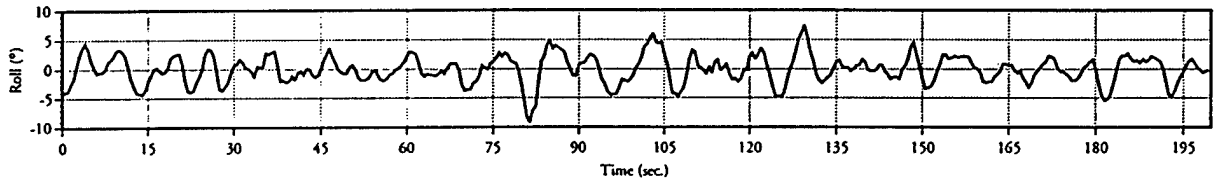
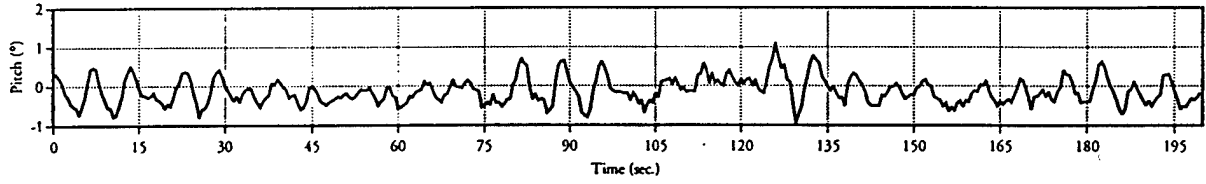
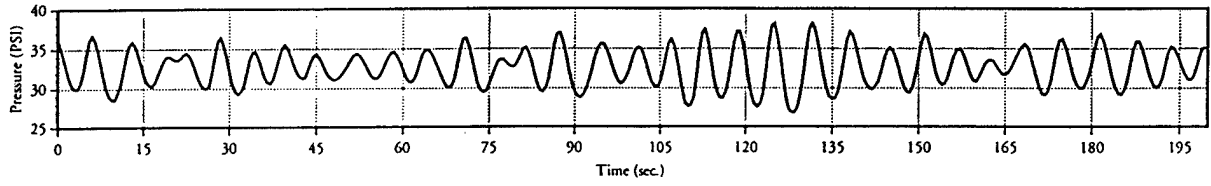
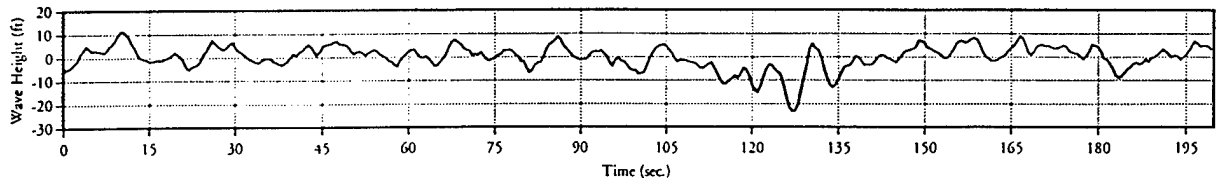

# RM17a Environmental Data

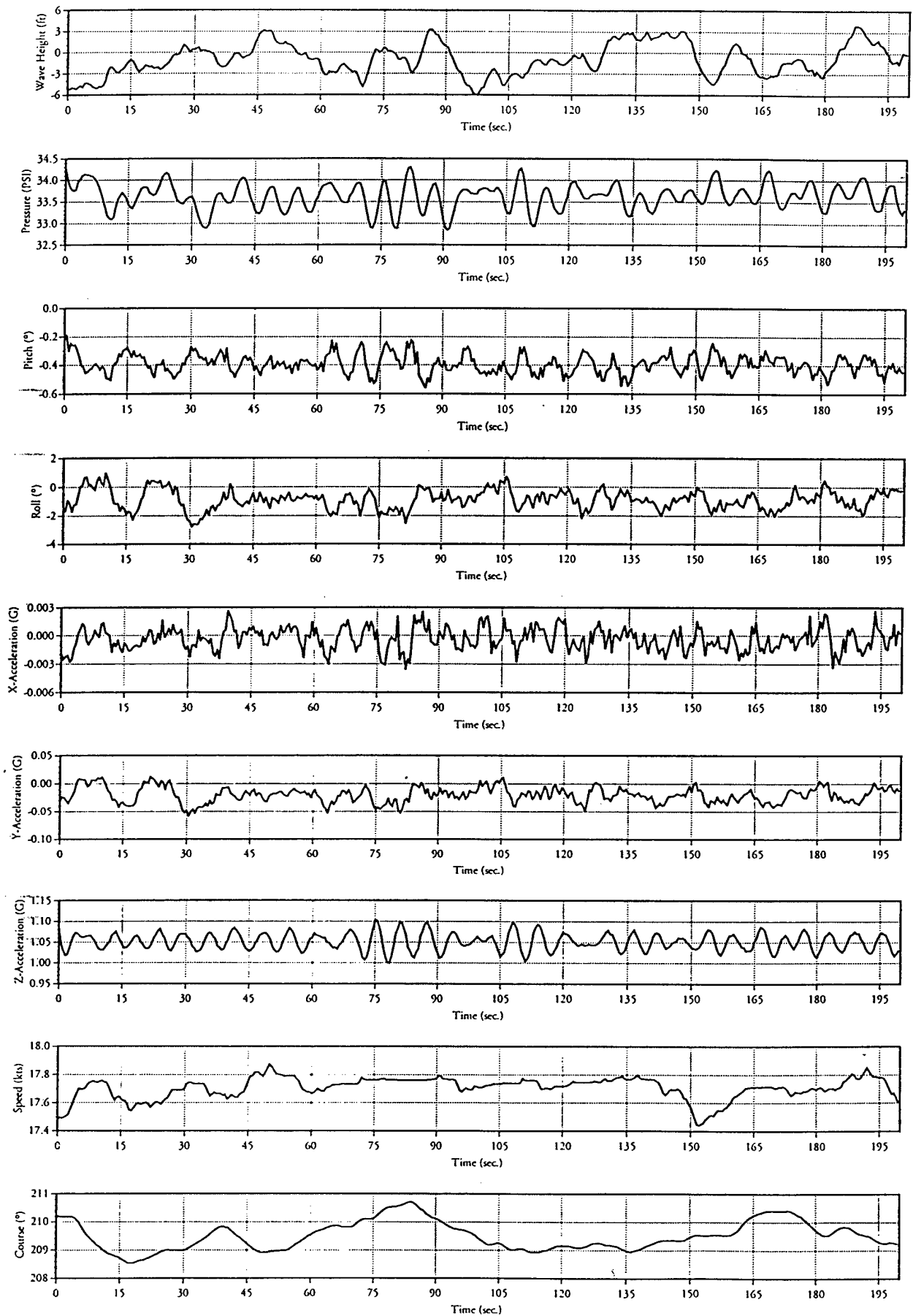

# RM17b Environmental Data

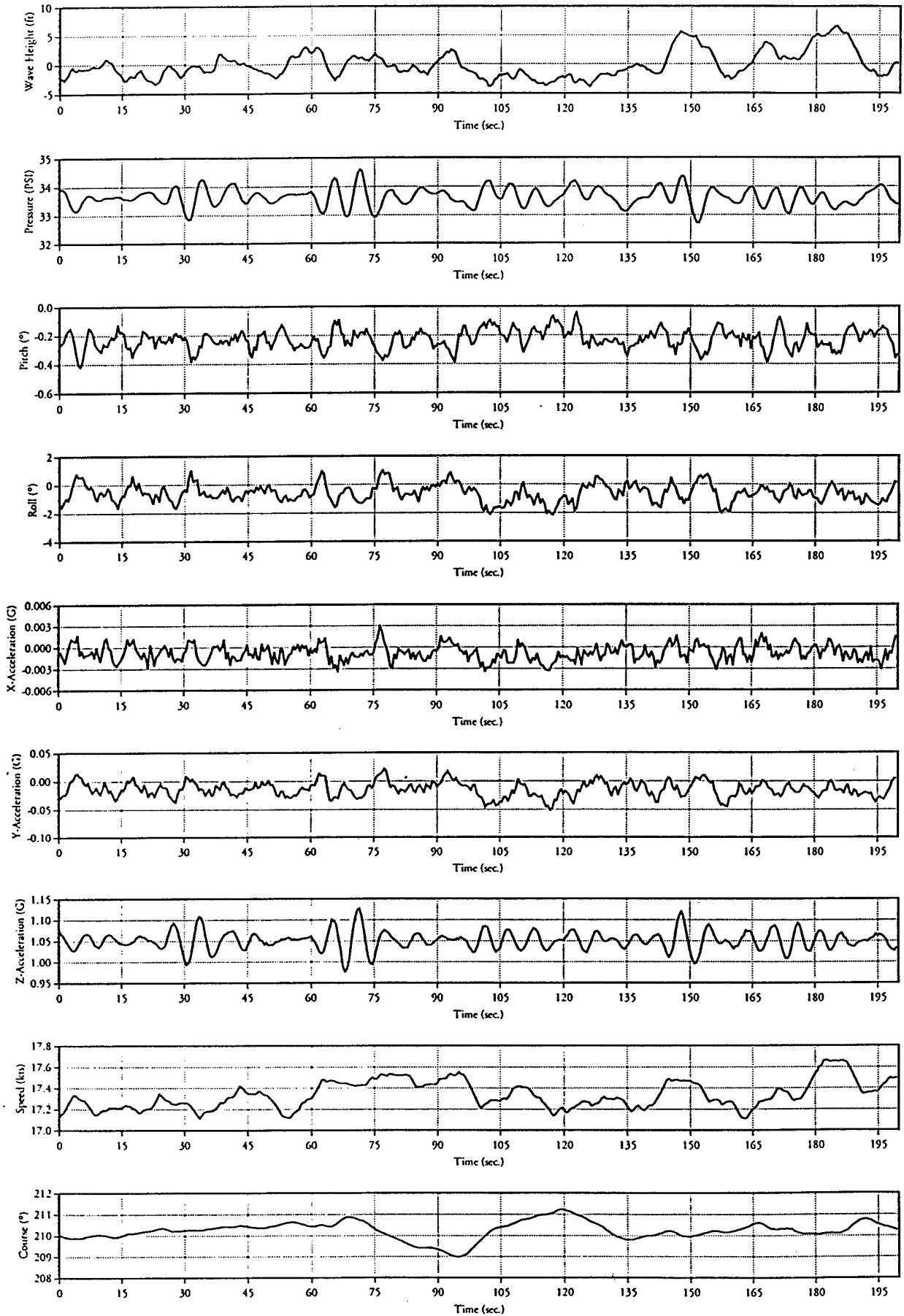

# RM5a Environmental Data

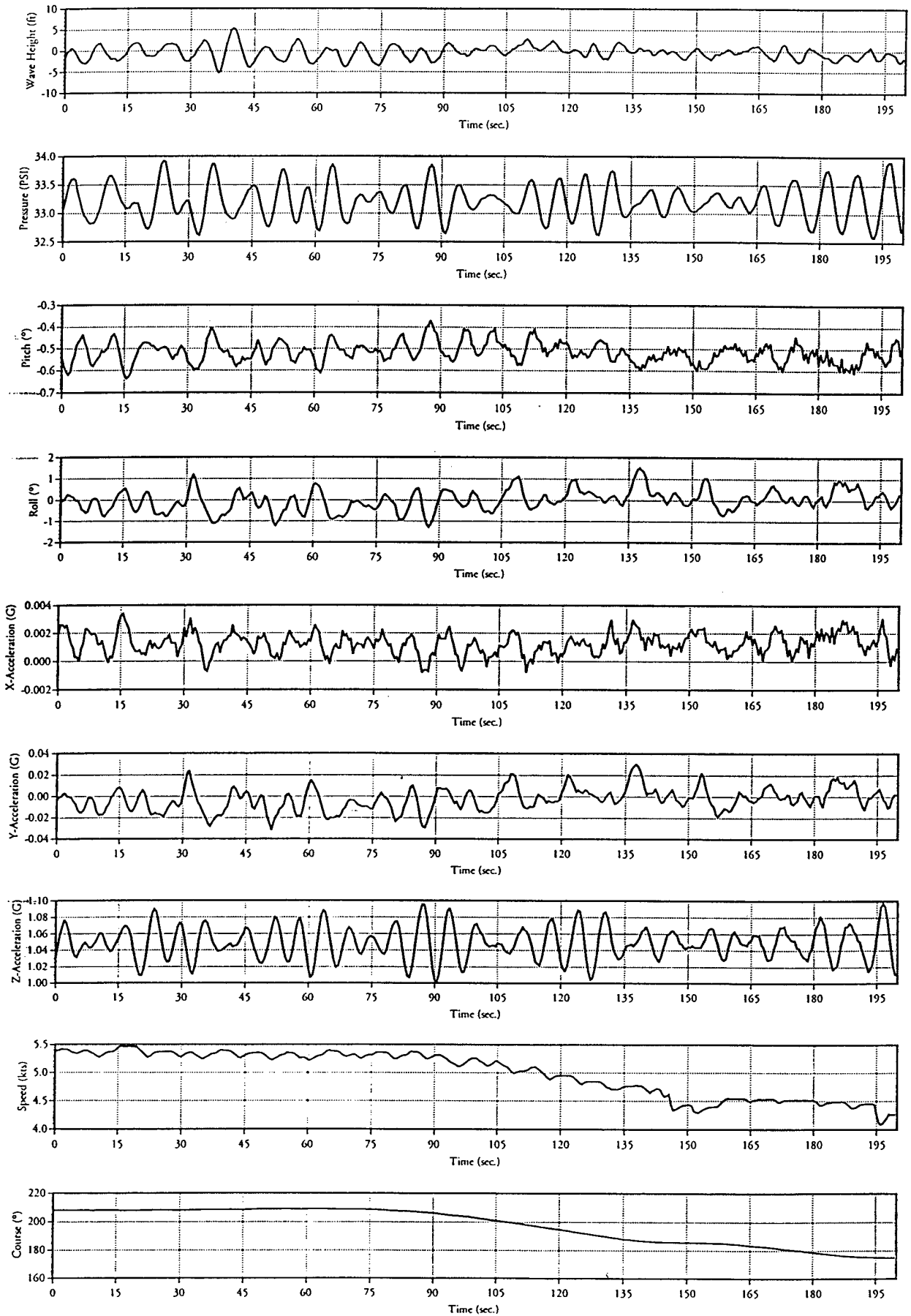

# Rn00a Environmental Data

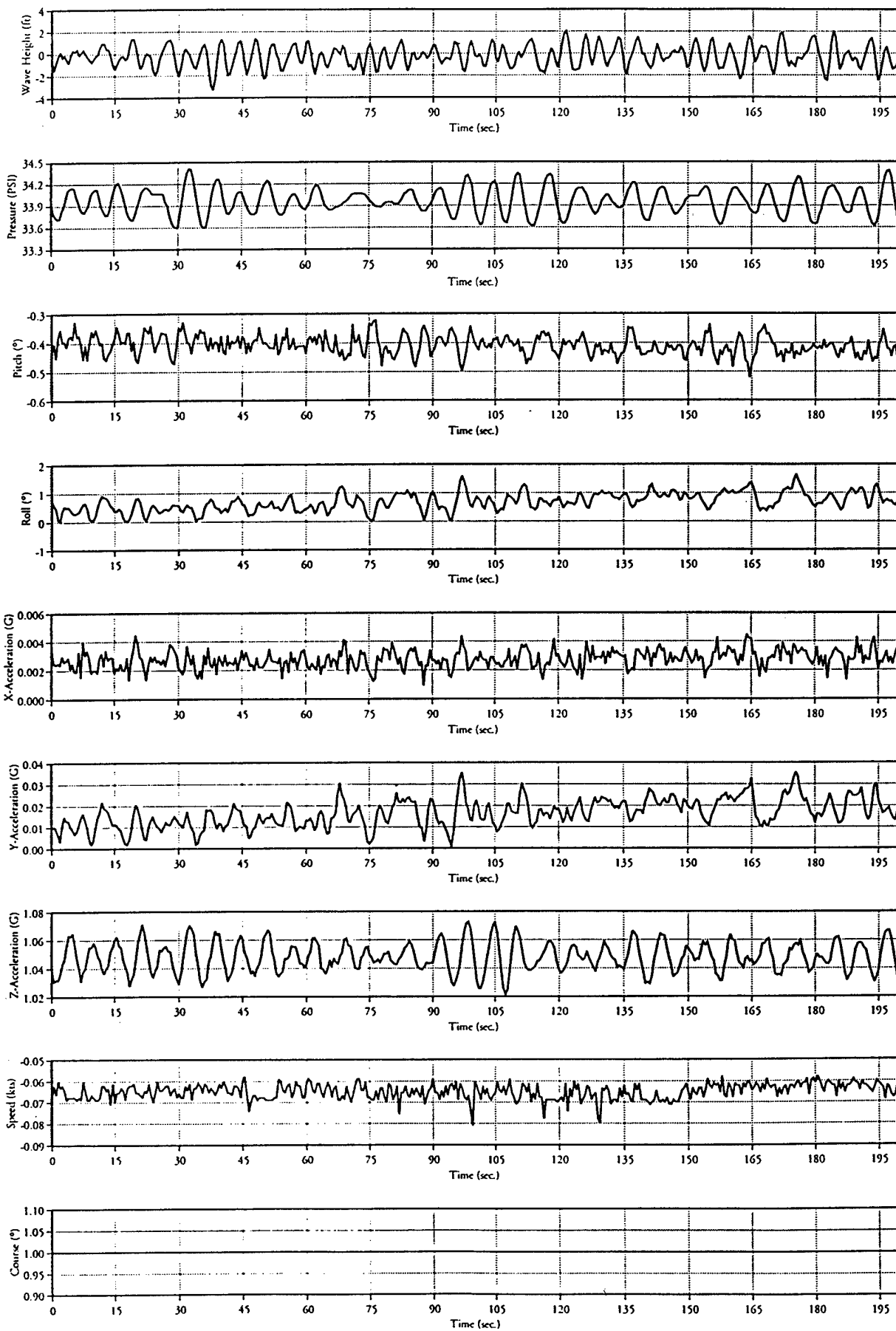



# Rn04a Environmental Data

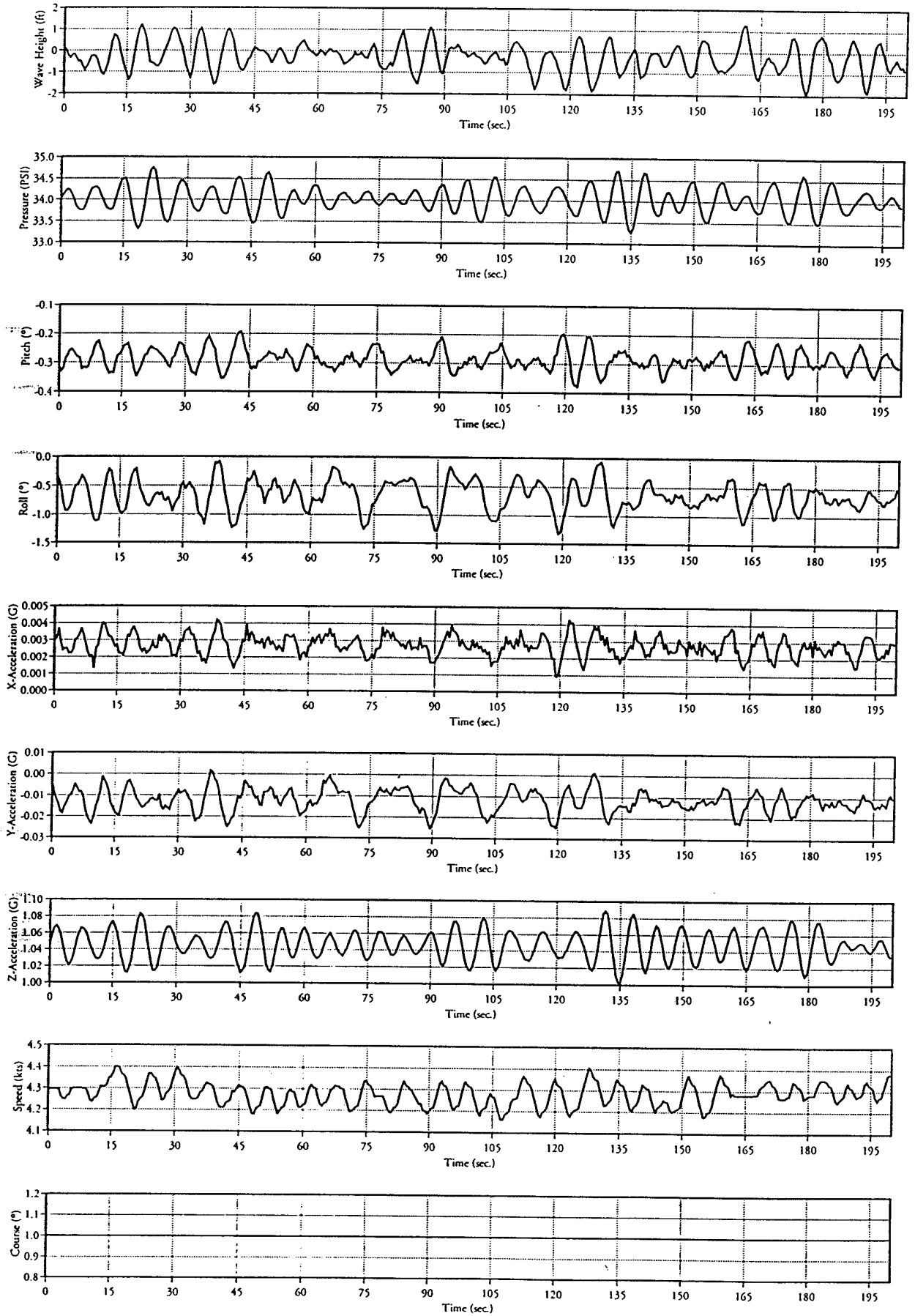

# Rn06a Environmental Data

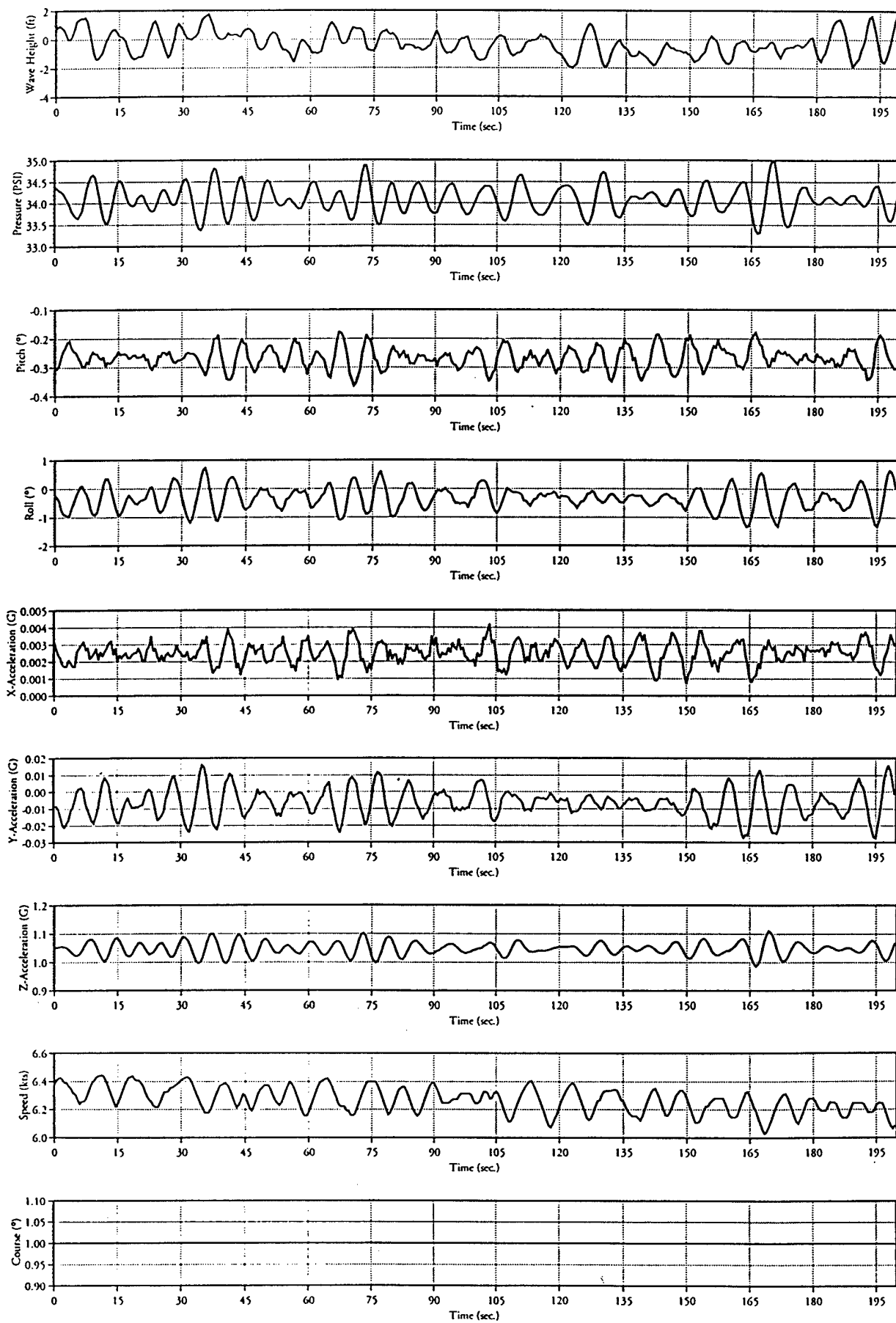

# Rn06b Environmental Data

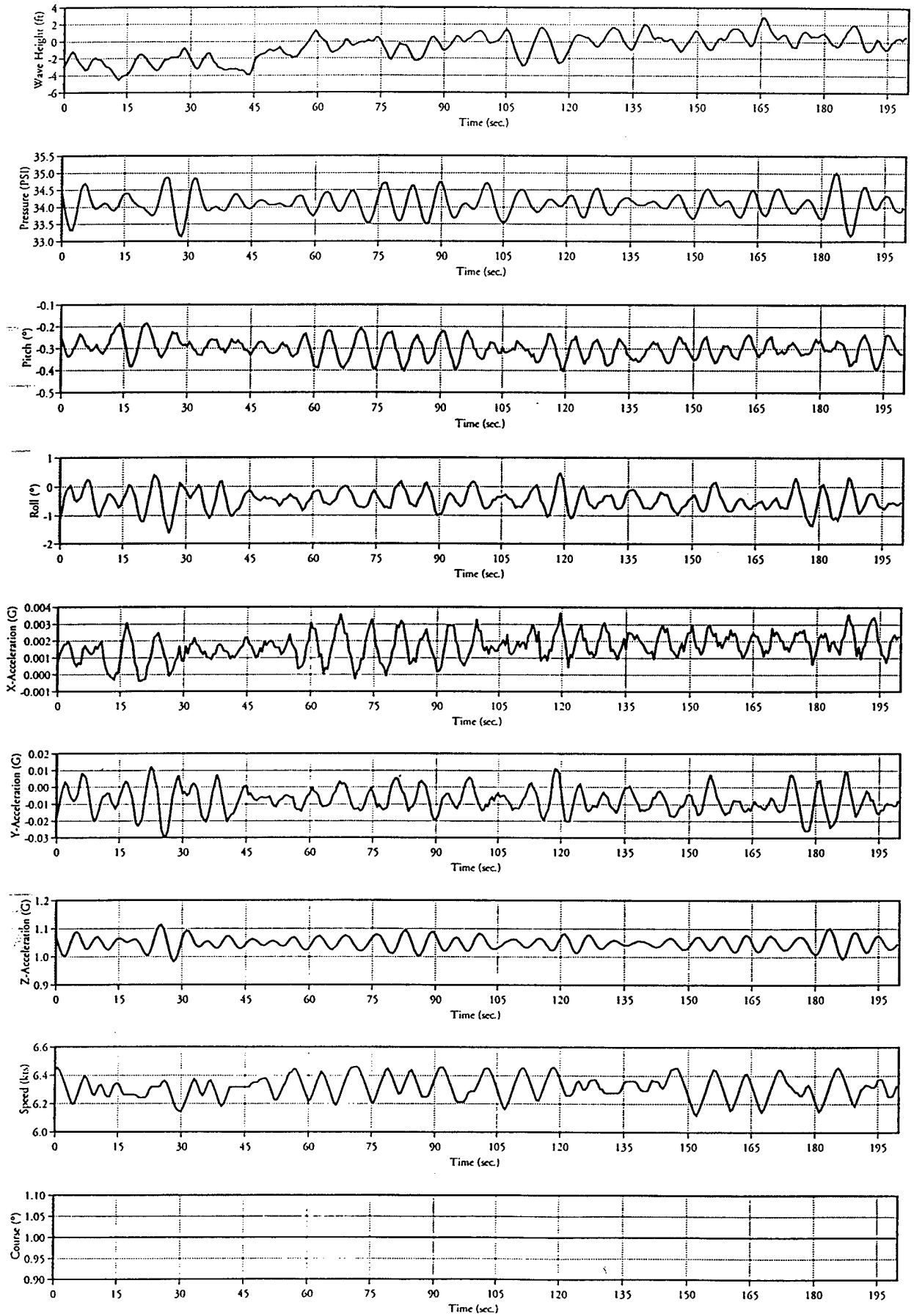

# RN10a Environmental Data

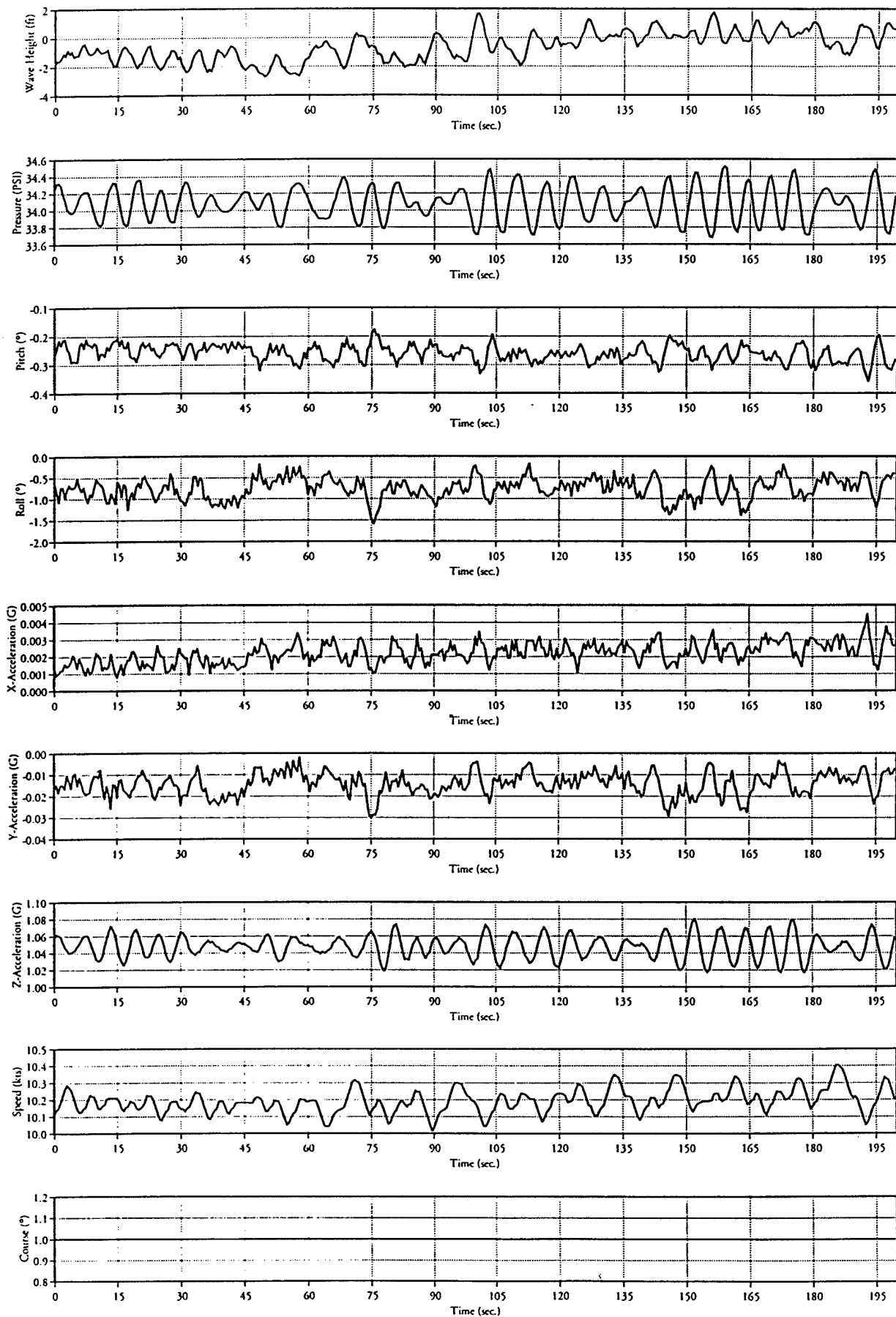

# Rn10b Environmental Data

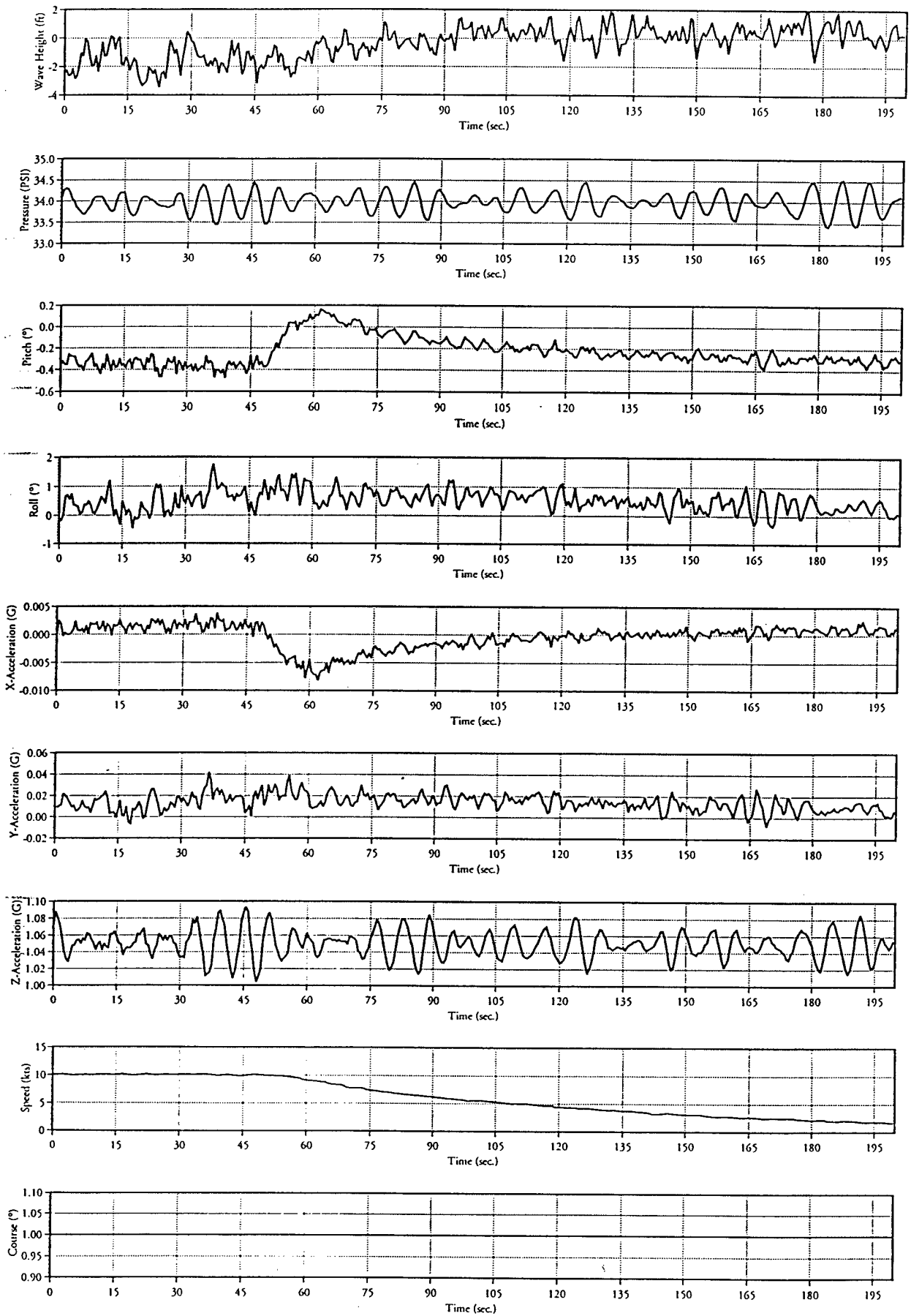

# Rn11a Environmental Data

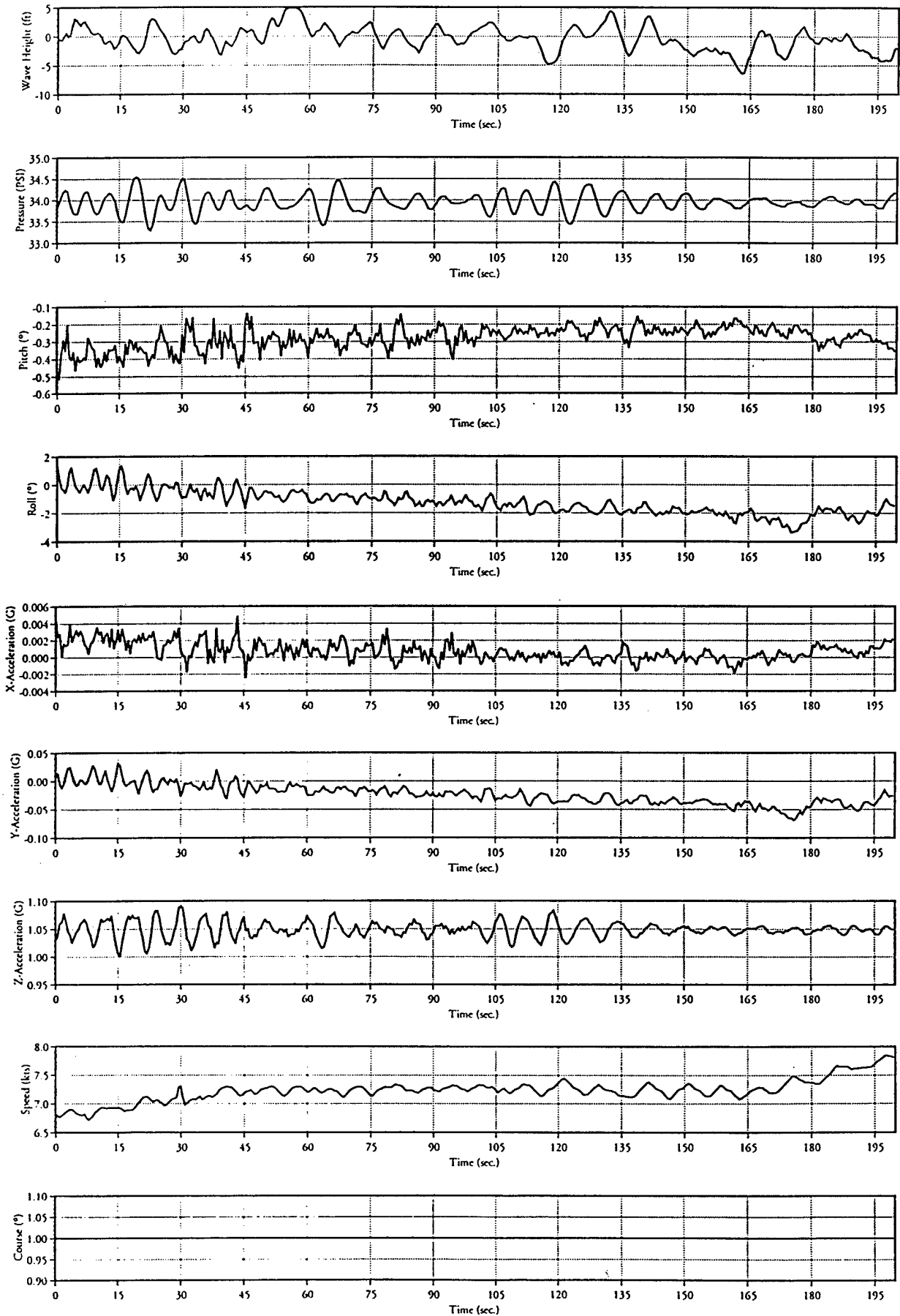

# Rn15a Environmental Data

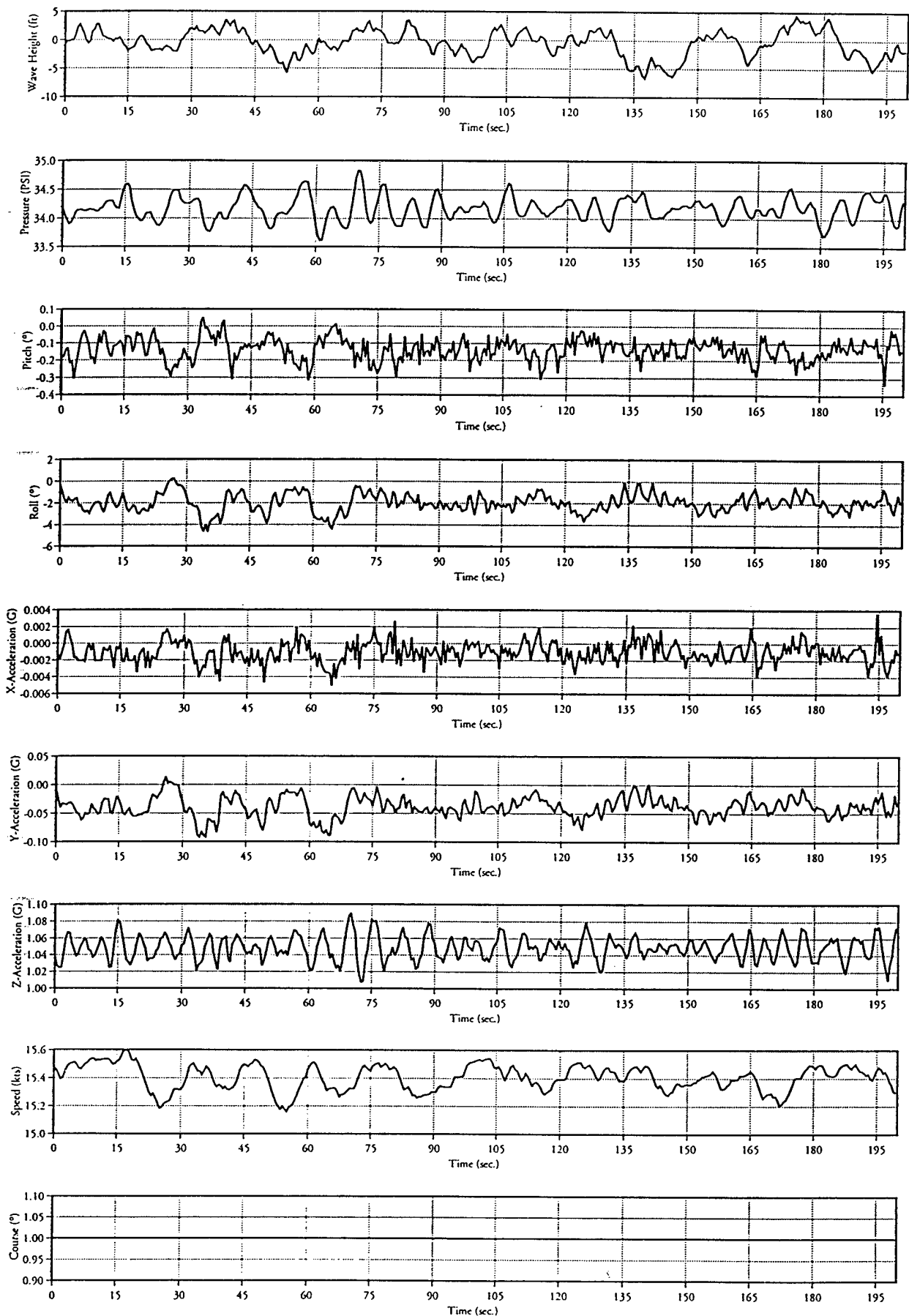

# Rn15b Environmental Data

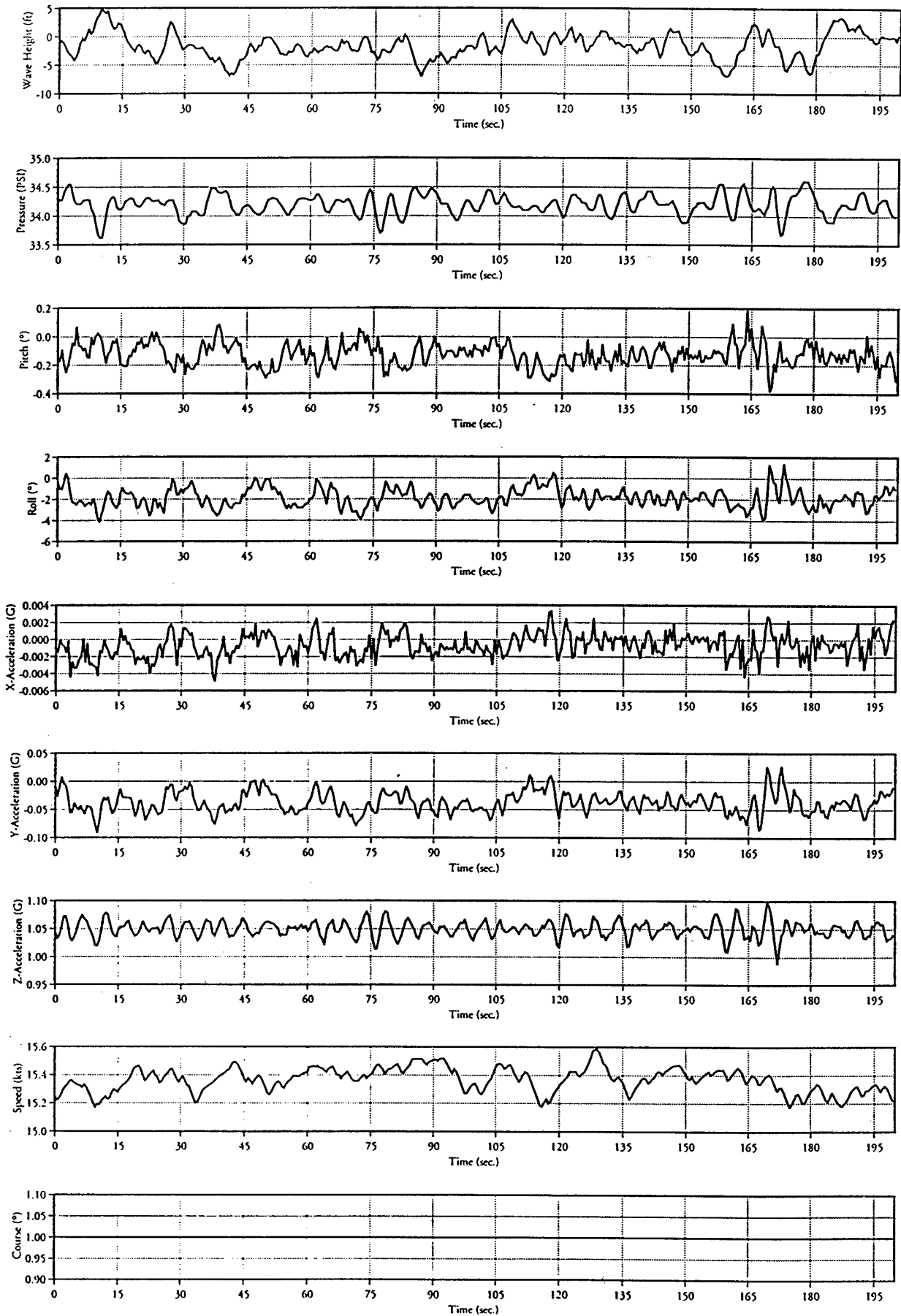



# Rp04a Environmental Data

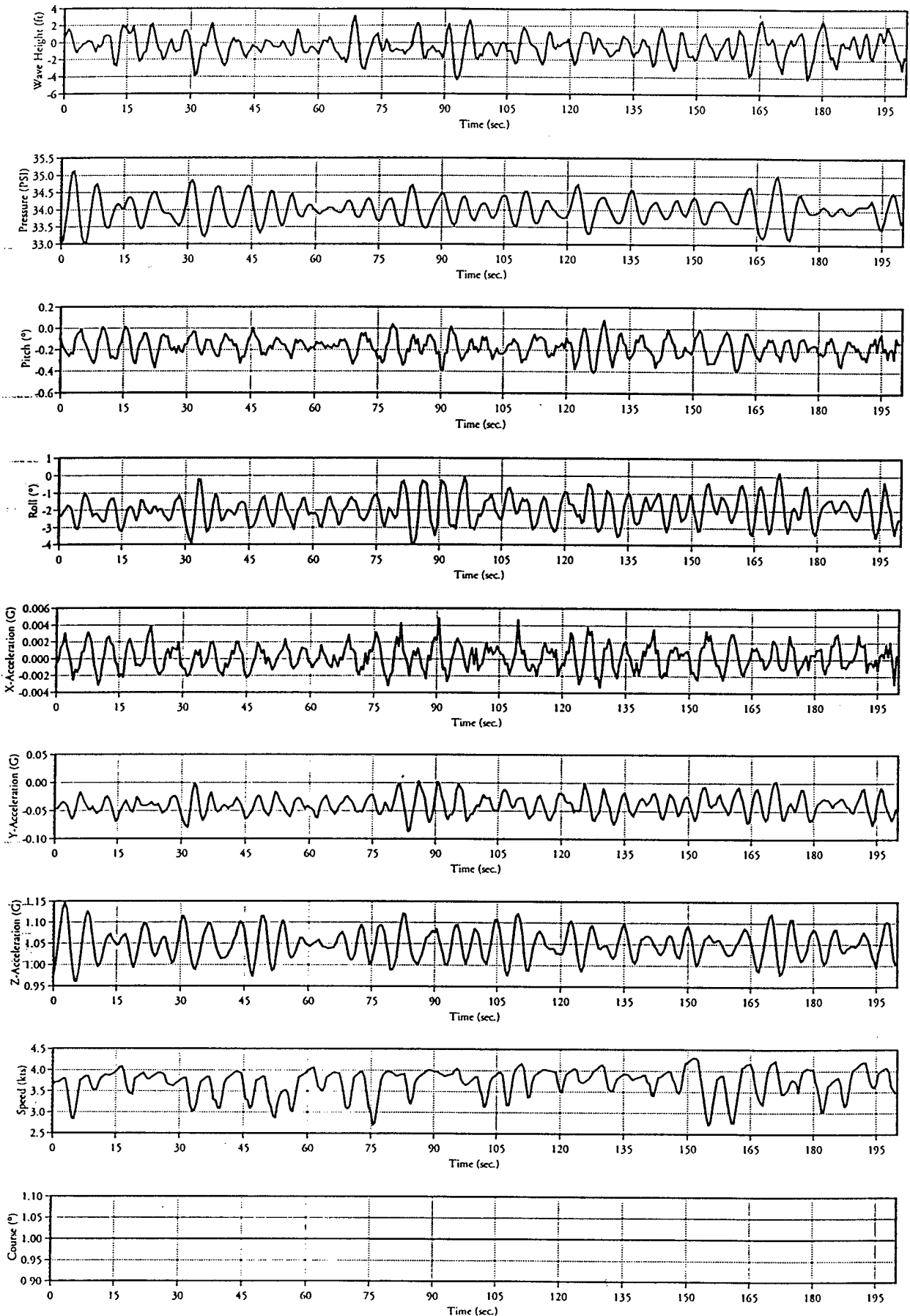

# Rp04b Environmental Data

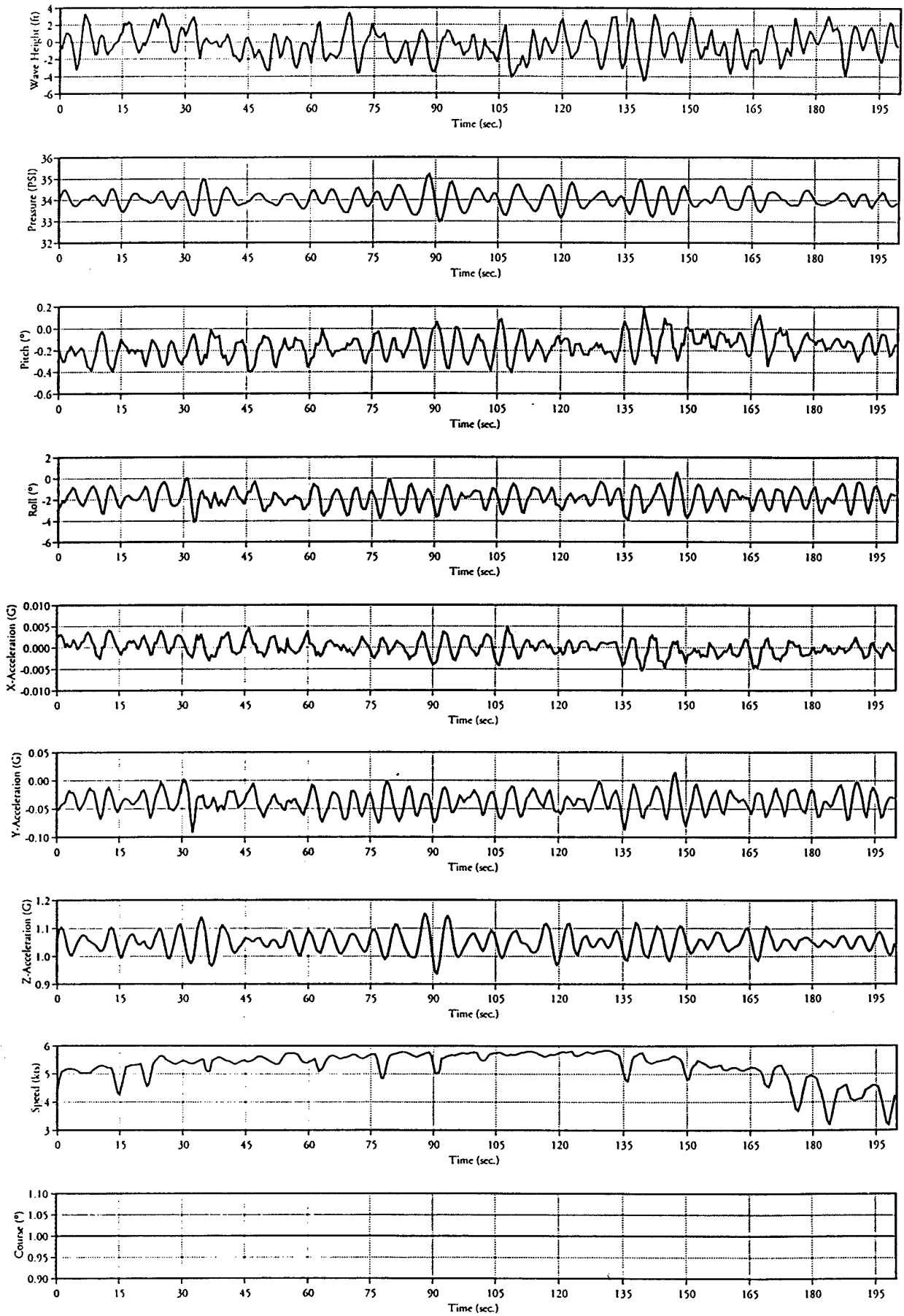

# Rp05a Environmental Data

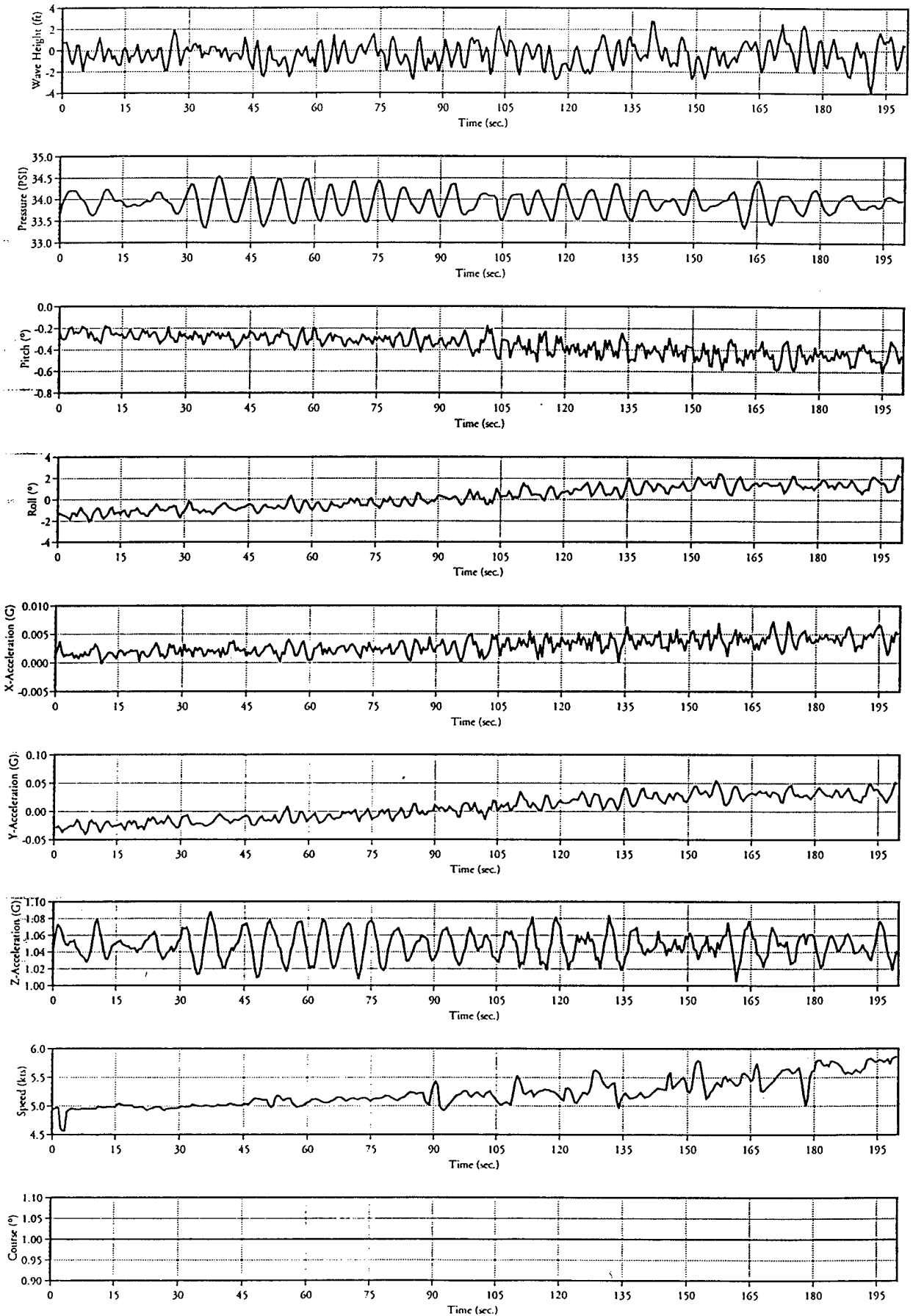

# Rp07a Environmental Data

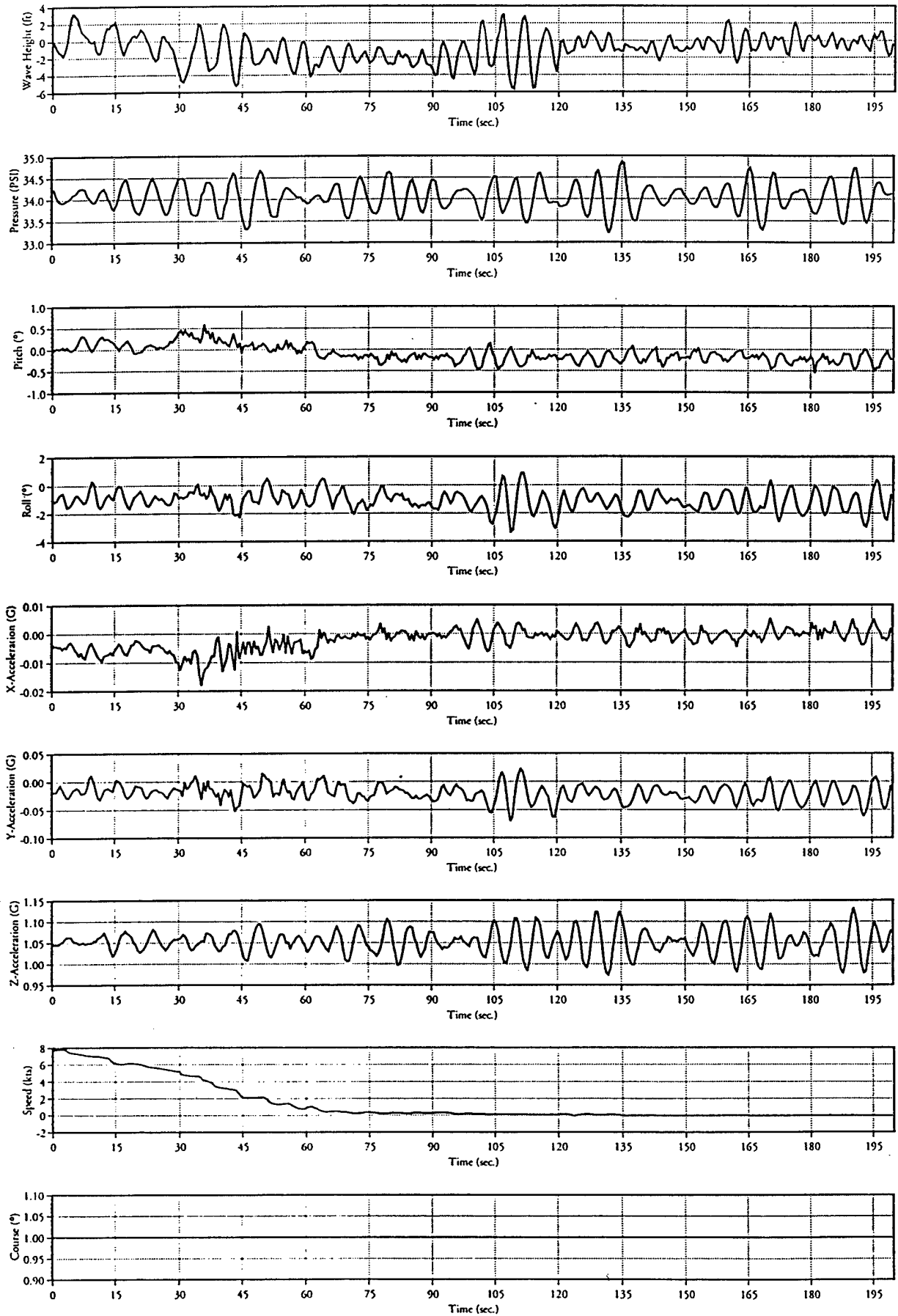

# Rp08a Environmental Data

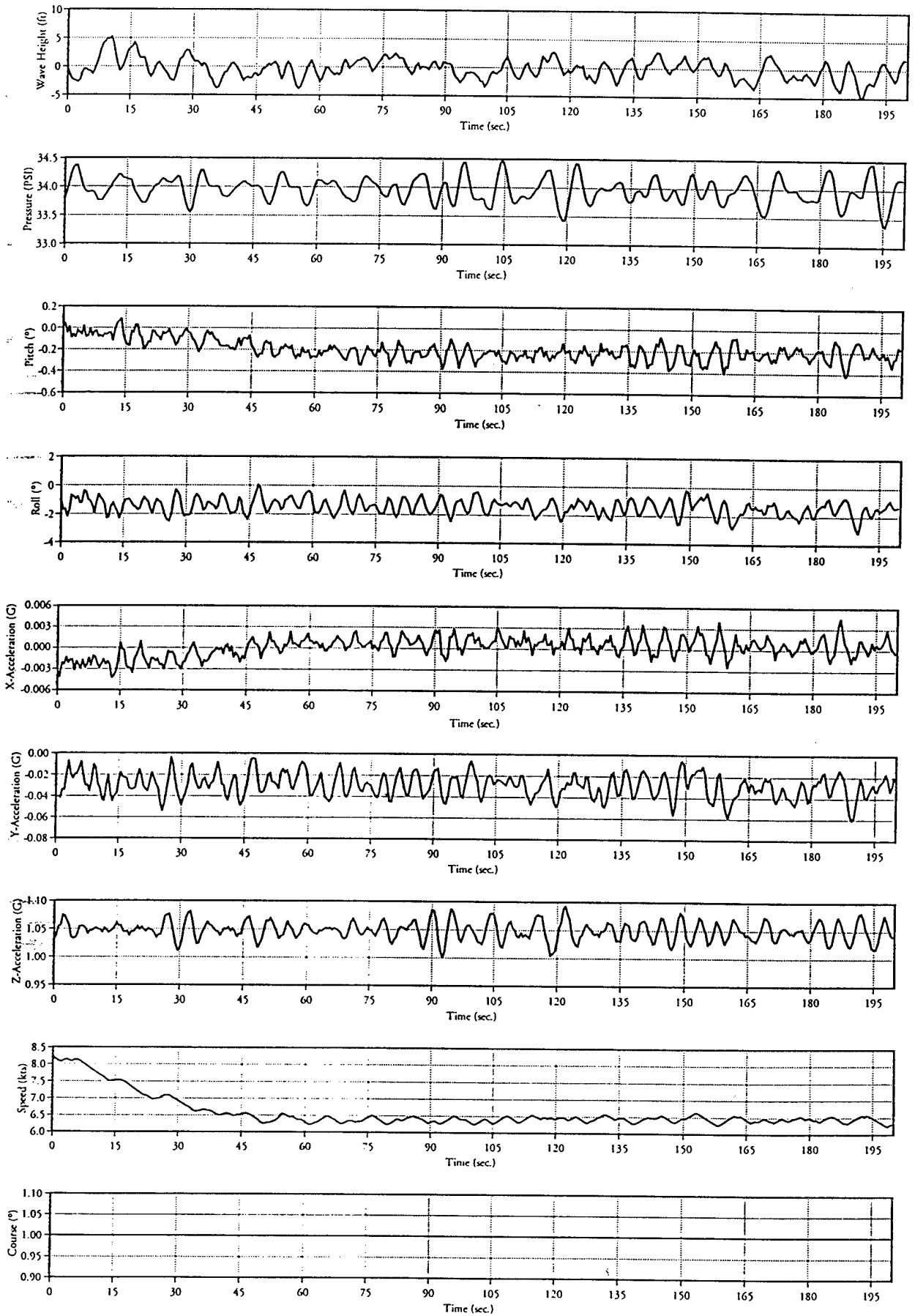

# Rp08b Environmental Data

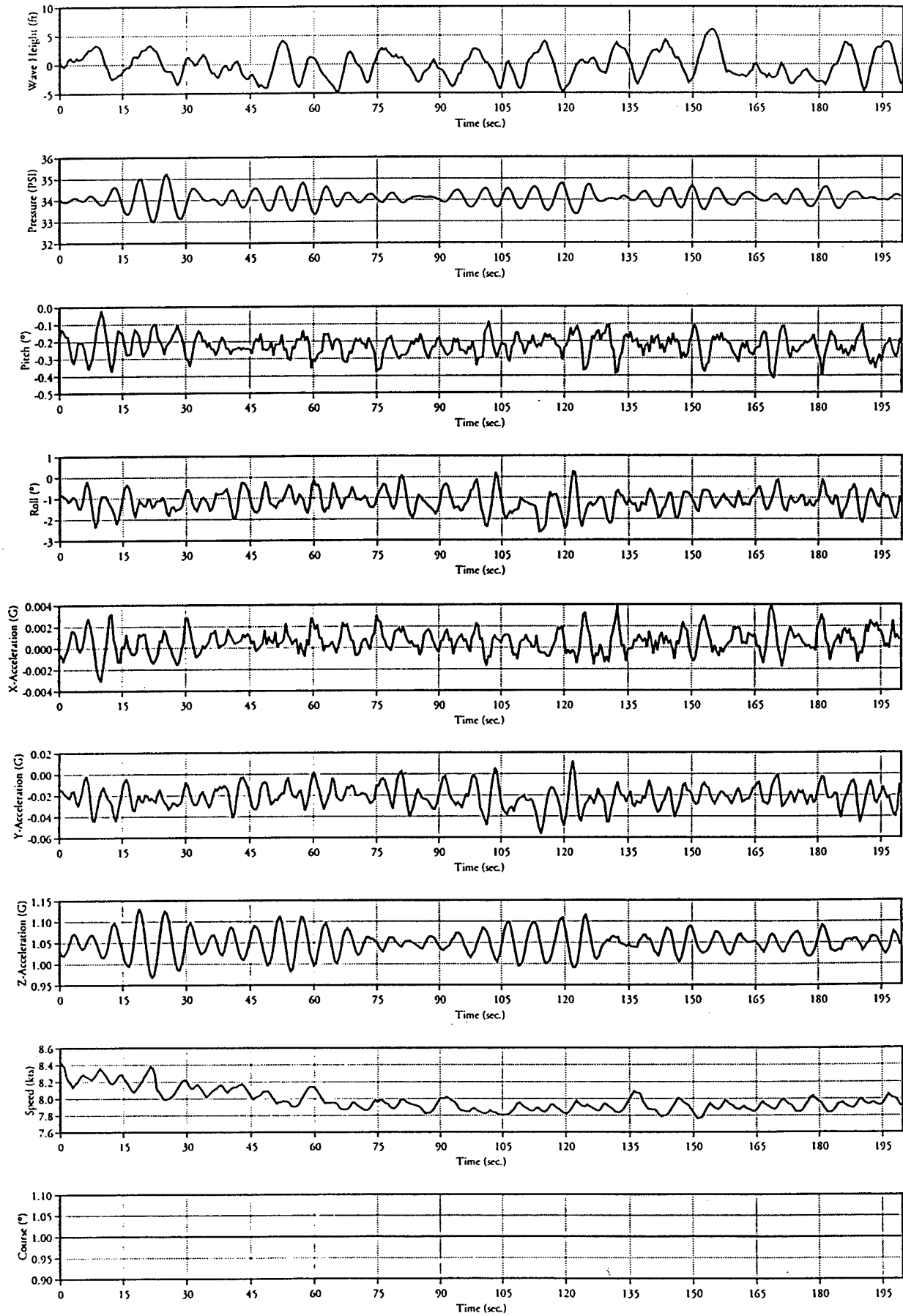

# Rp09a Environmental Data

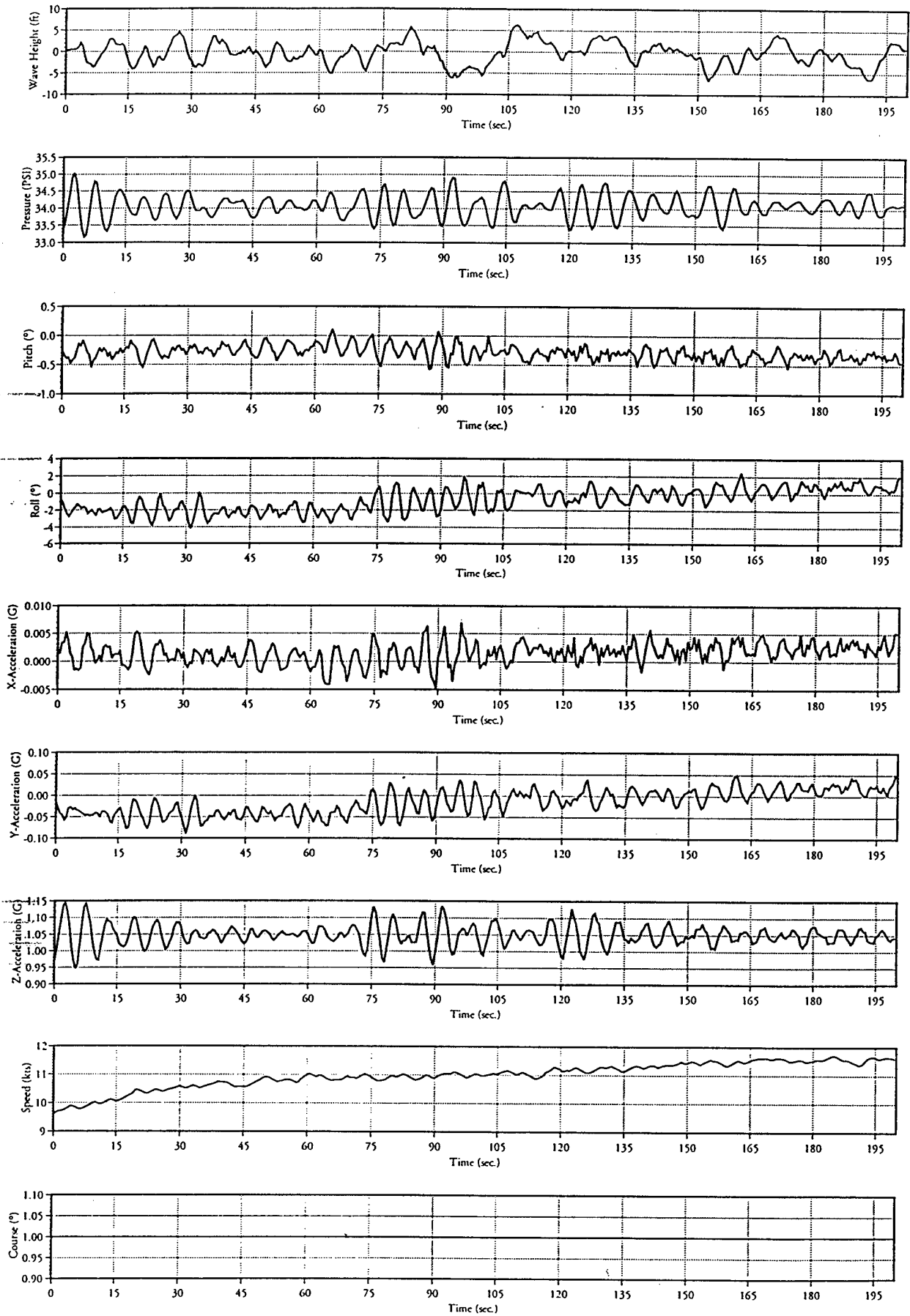

# Rp09b Environmental Data

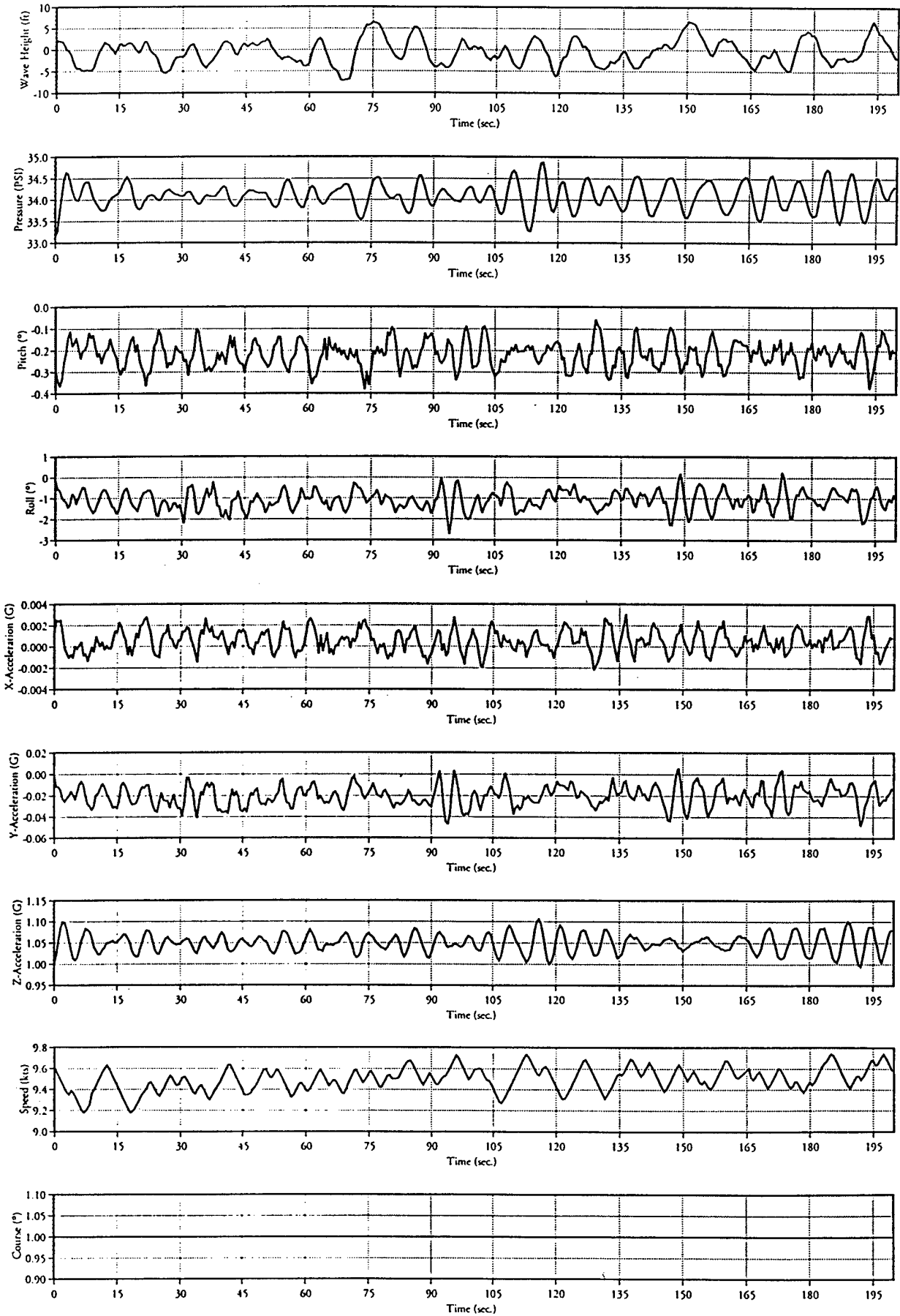



# Rp10a Environmental Data

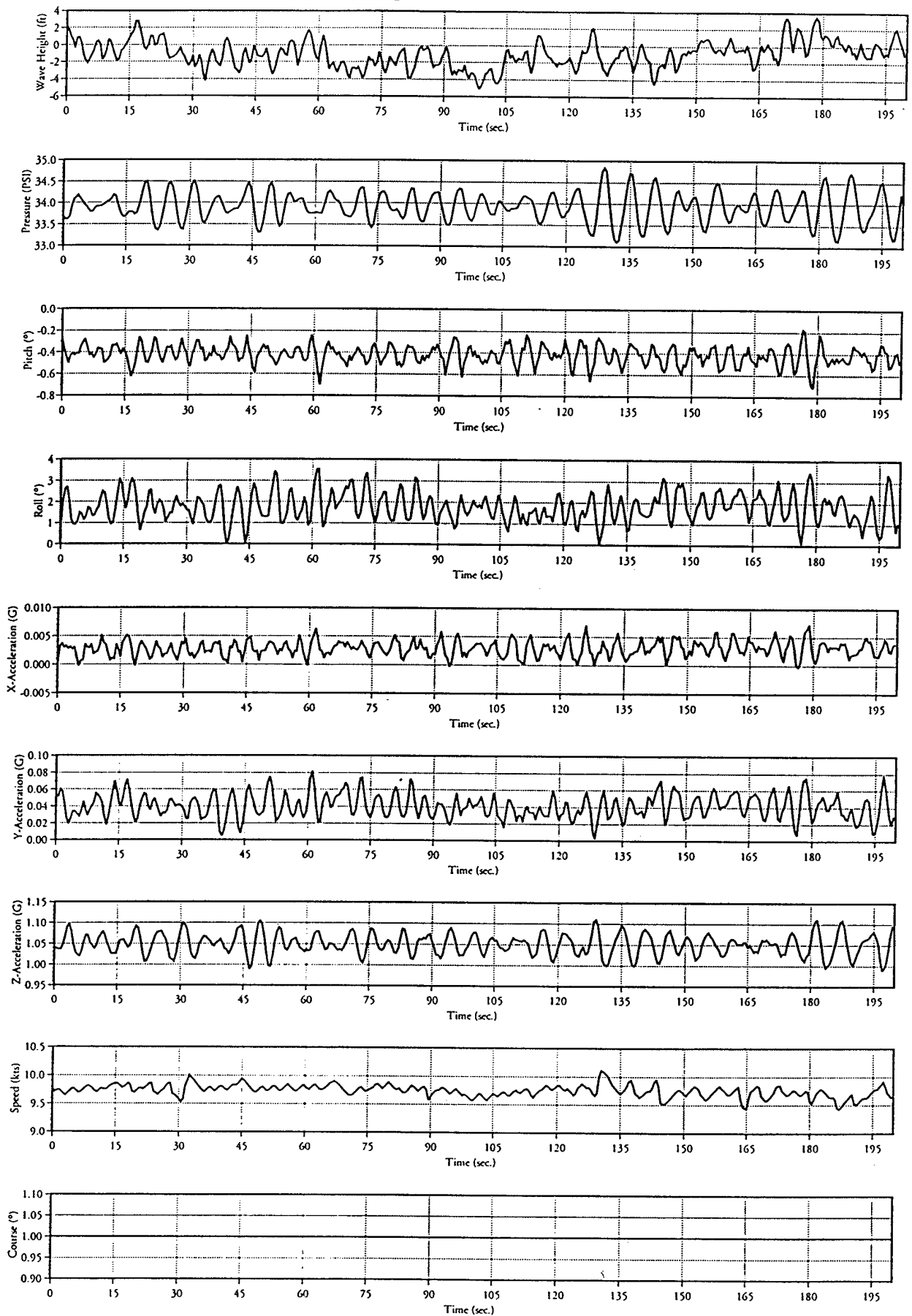

# Rp11a Environmental Data

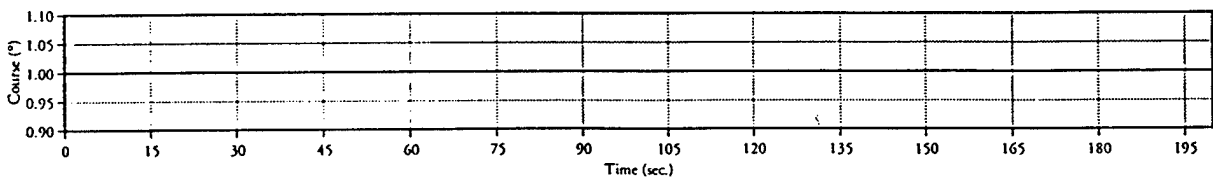
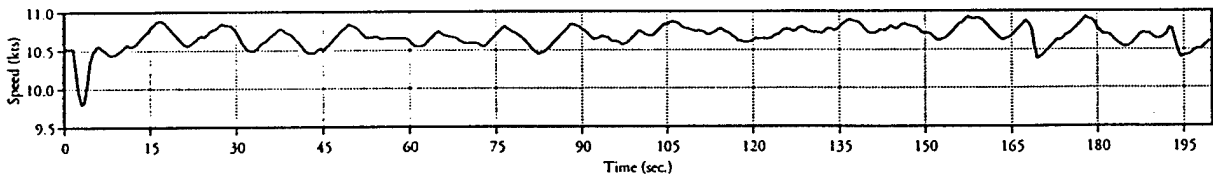
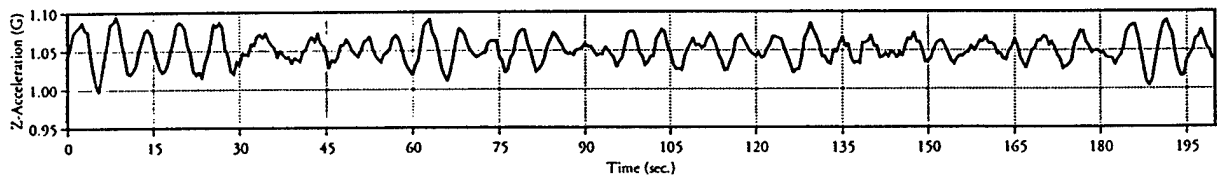
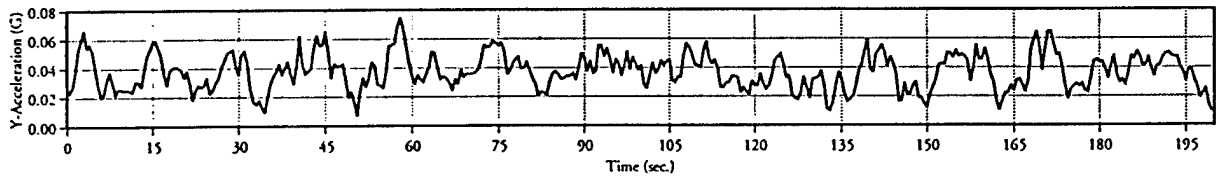
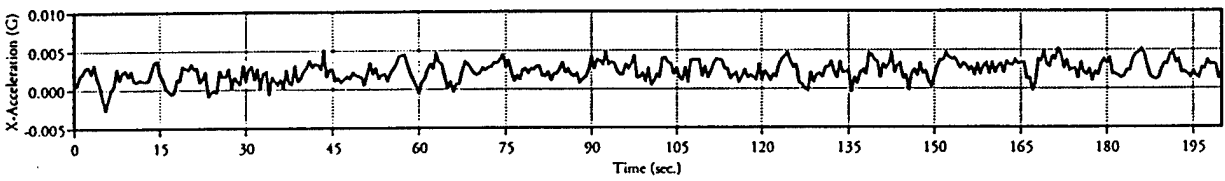
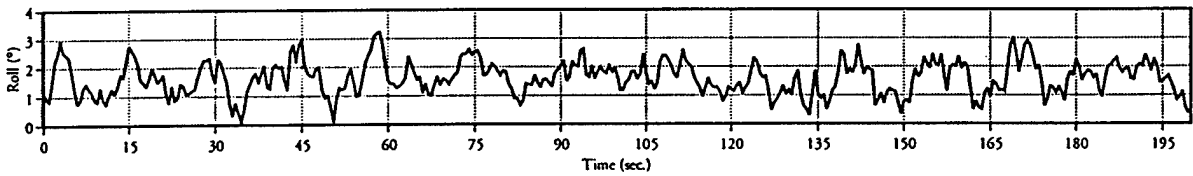
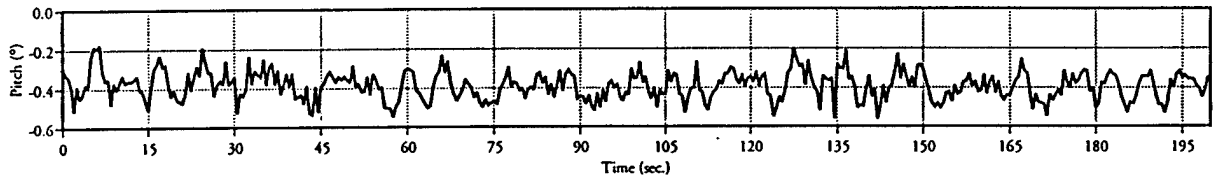
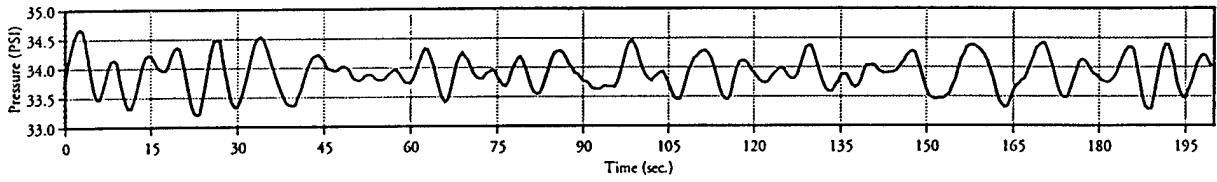
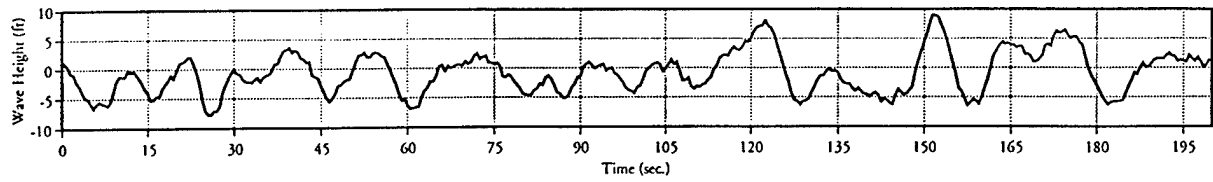

# Rp13a Environmental Data

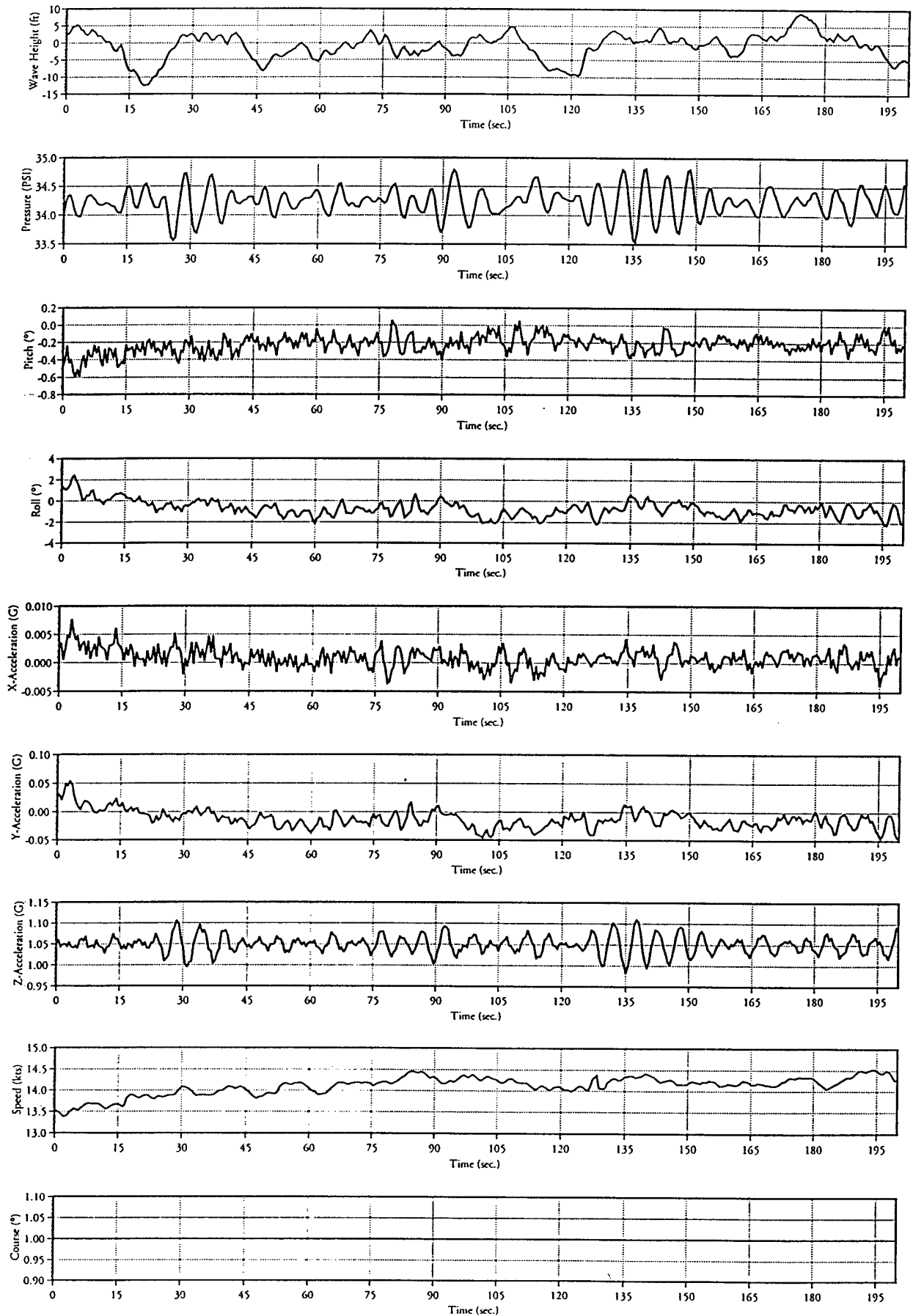

# Rp20a Environmental Data

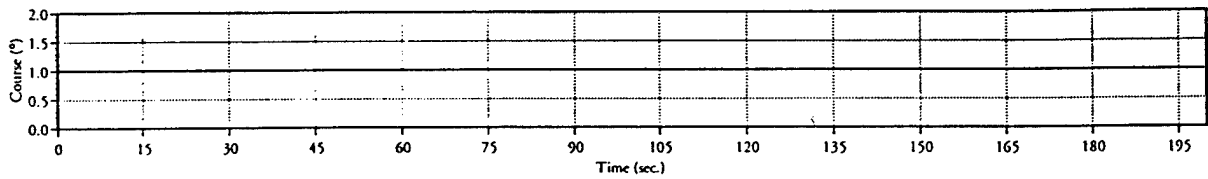
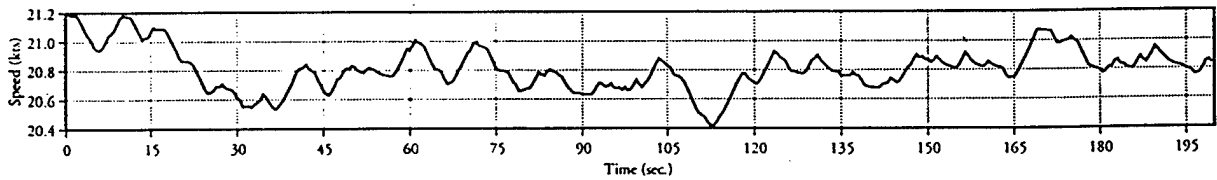
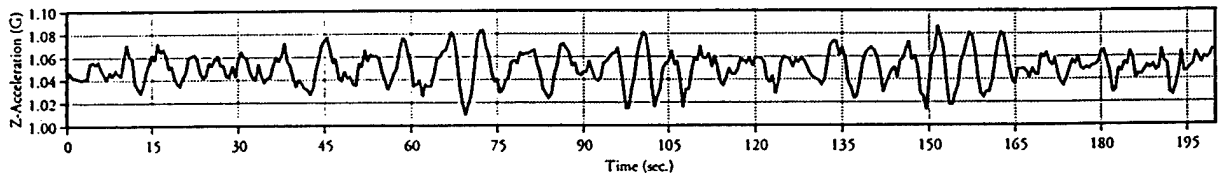
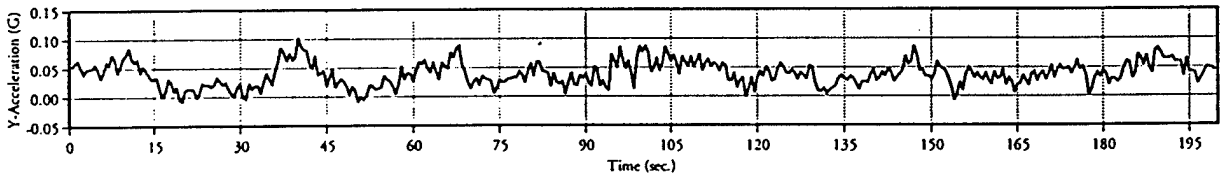
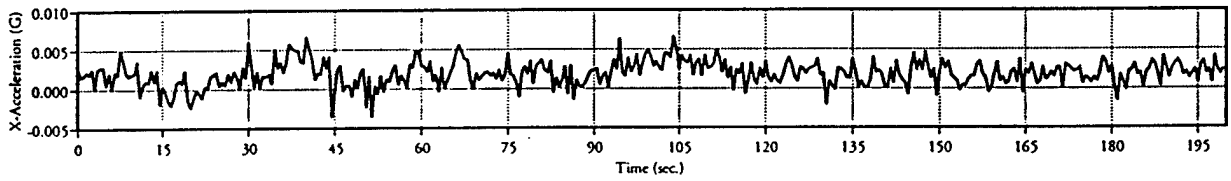
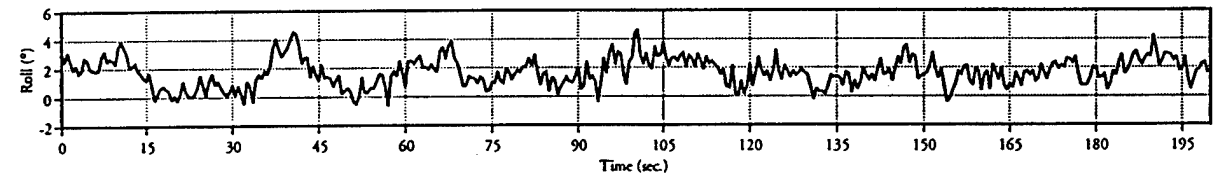
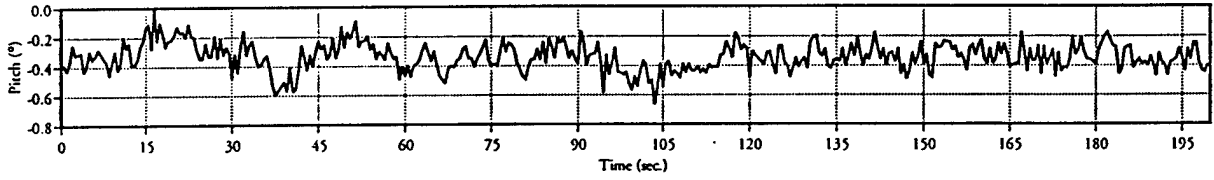
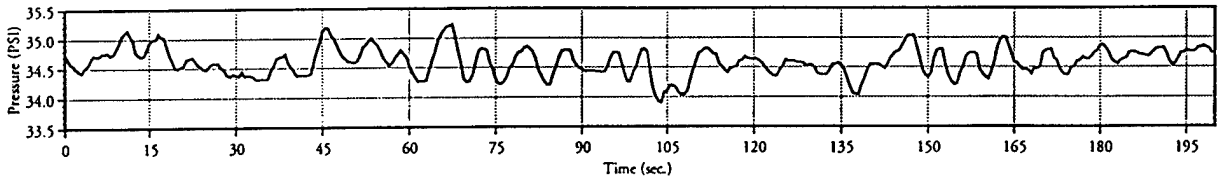
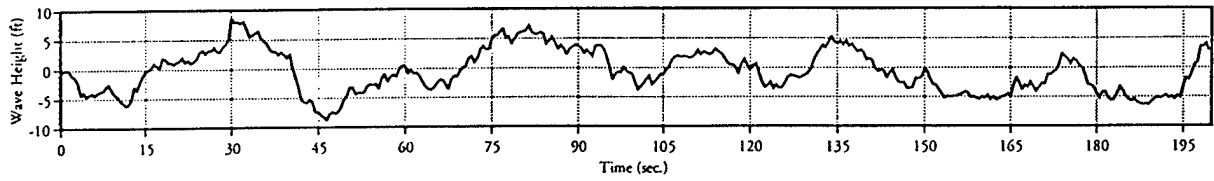

# Rp20b Environmental Data

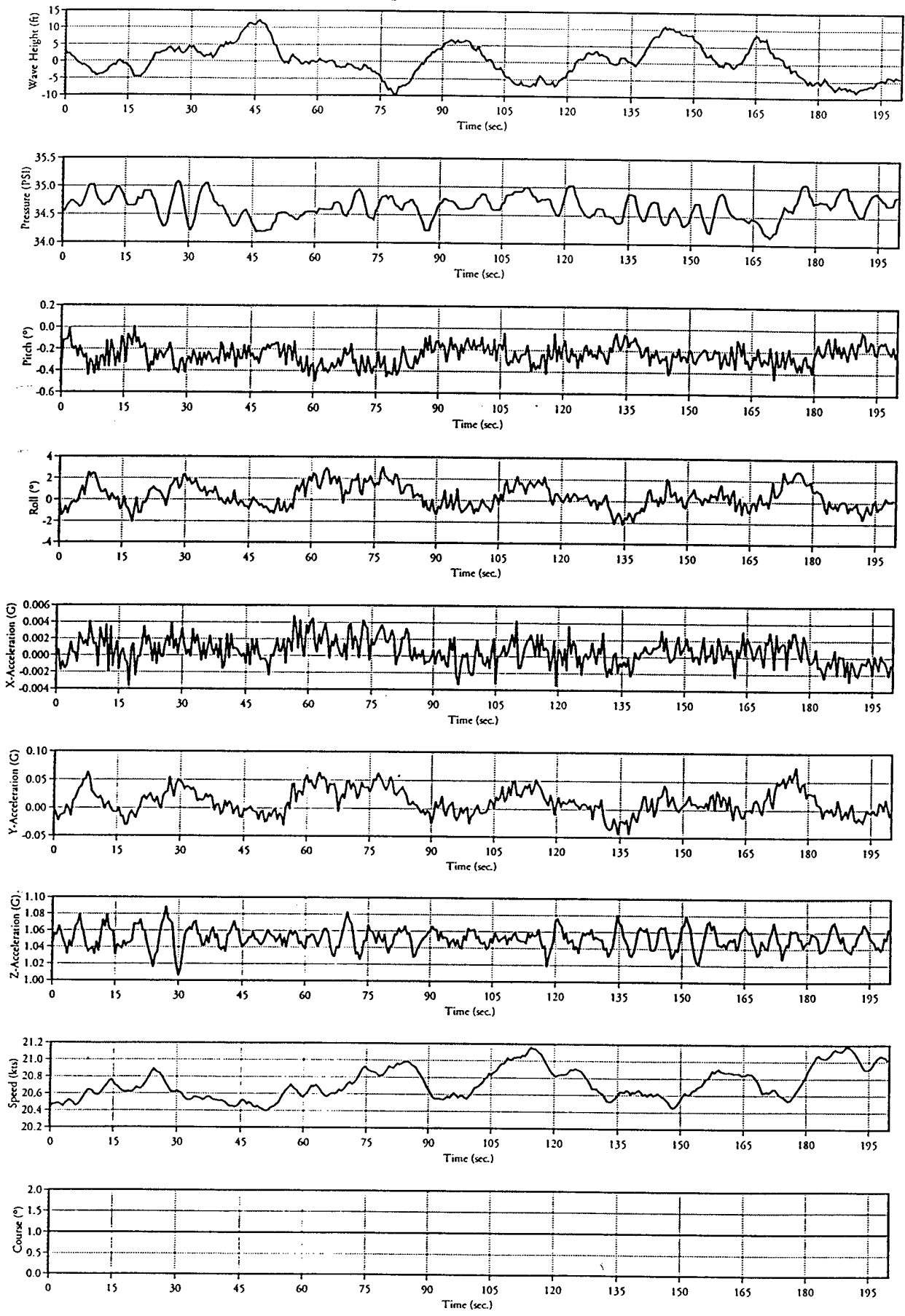

# Rp21a Environmental Data

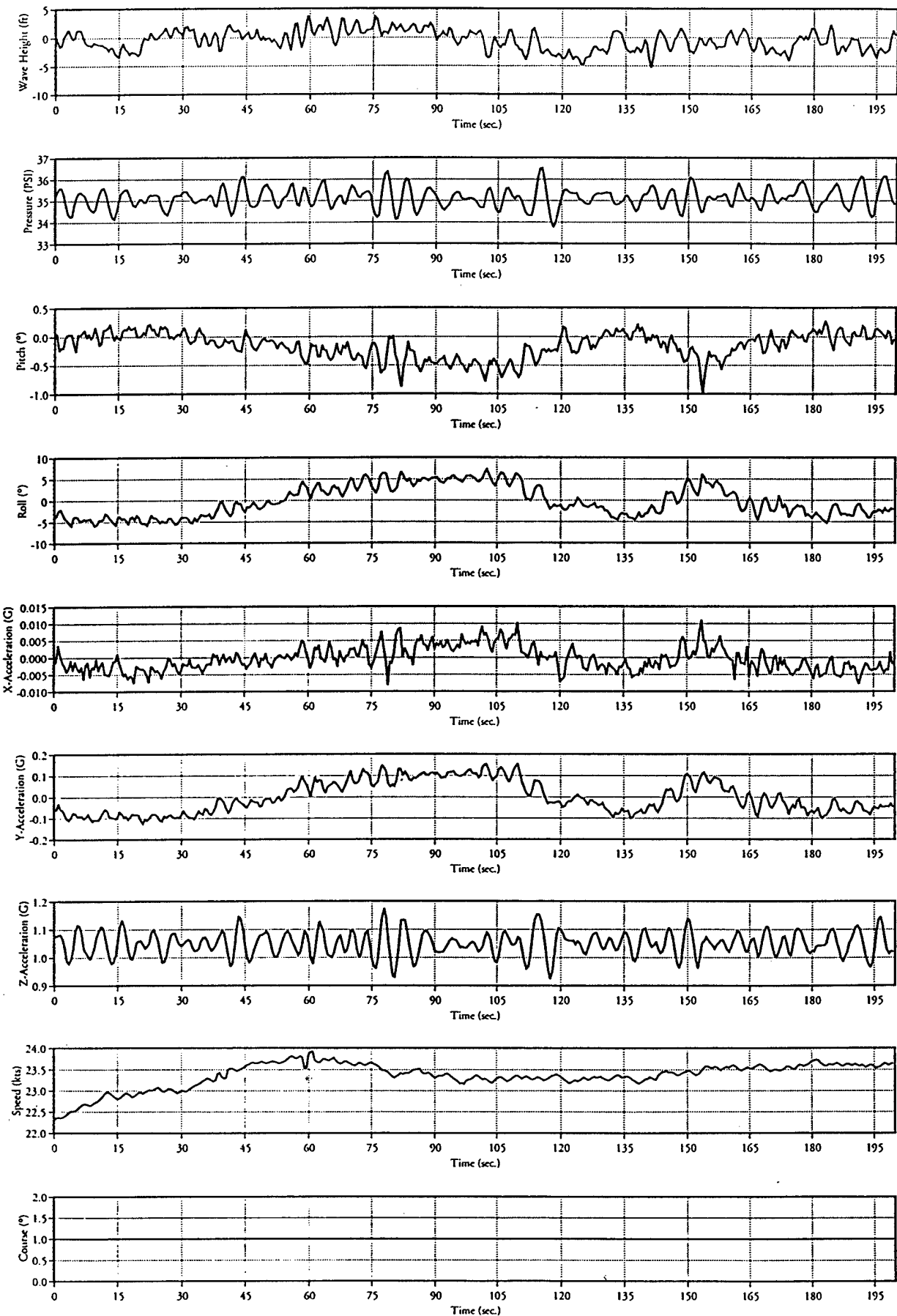

# Rq05a Environmental Data

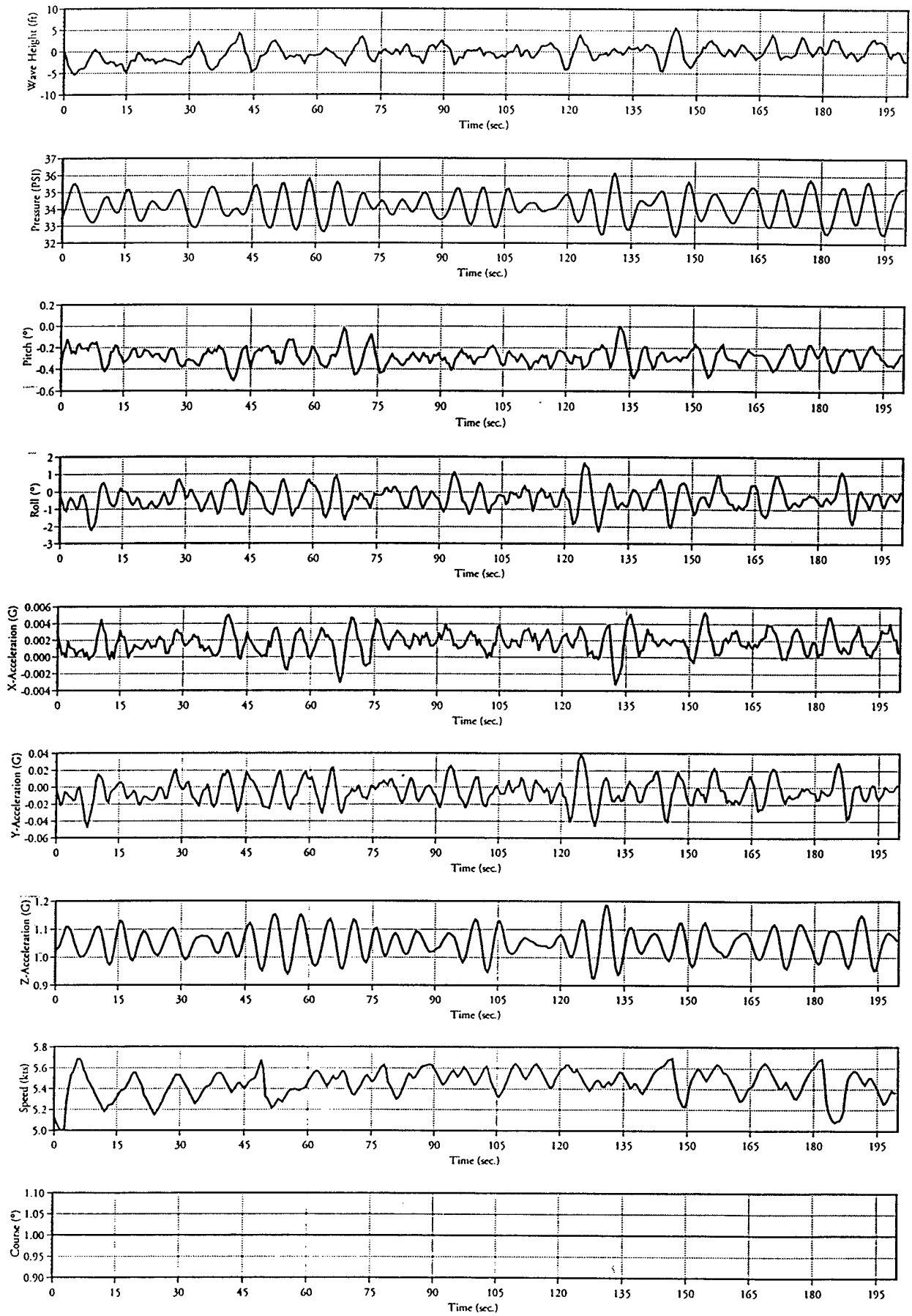

# Rq18a Environmental Data

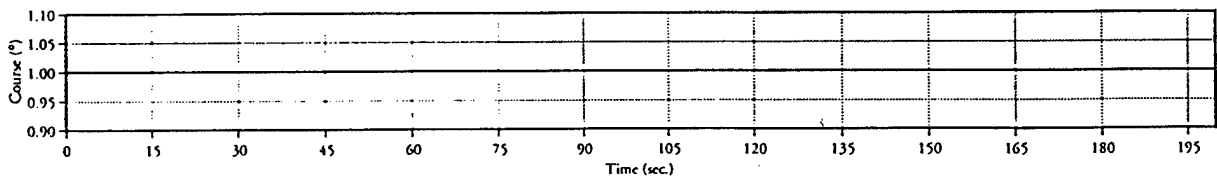
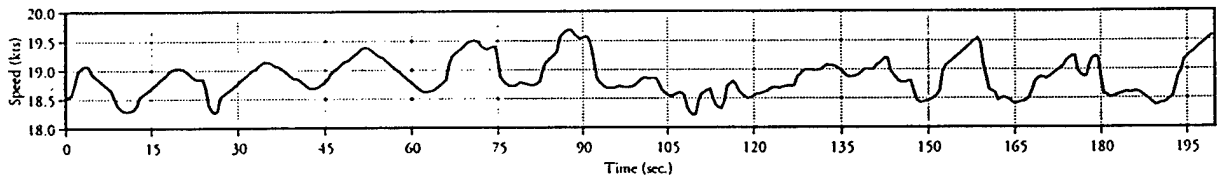
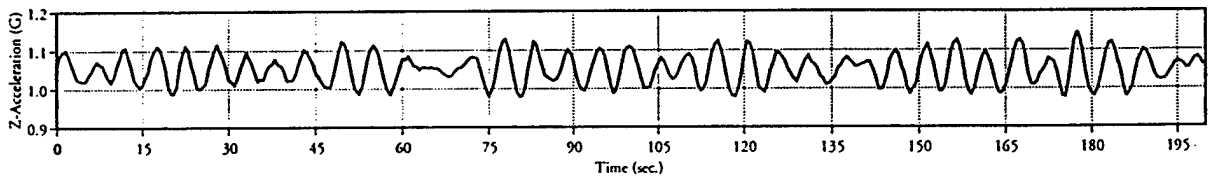
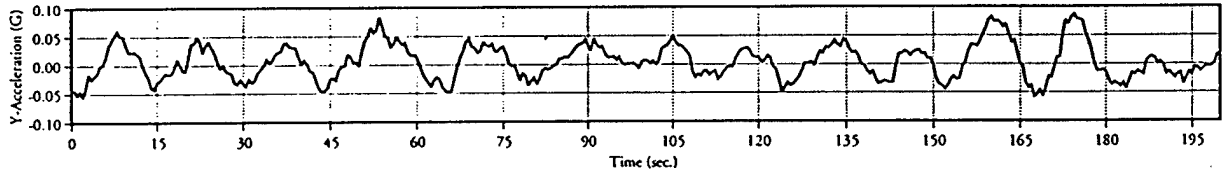
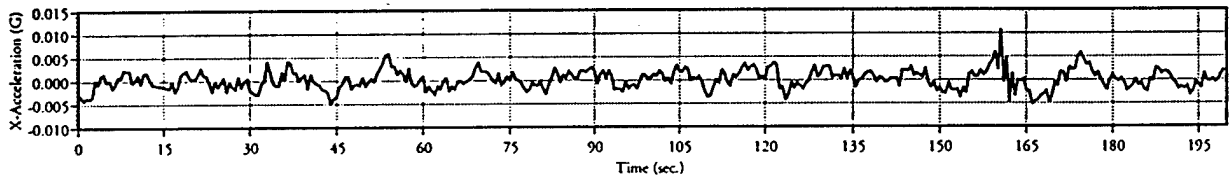
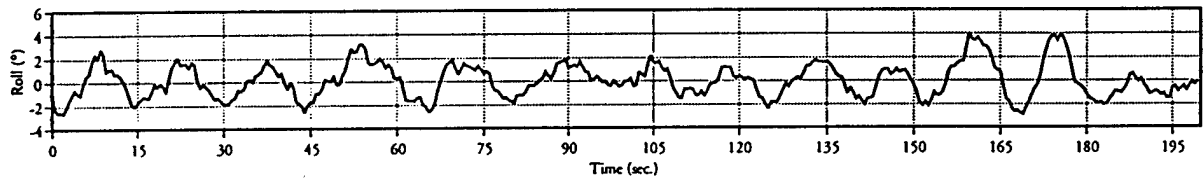
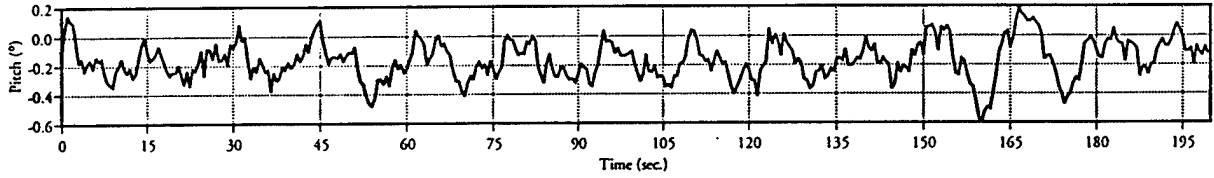
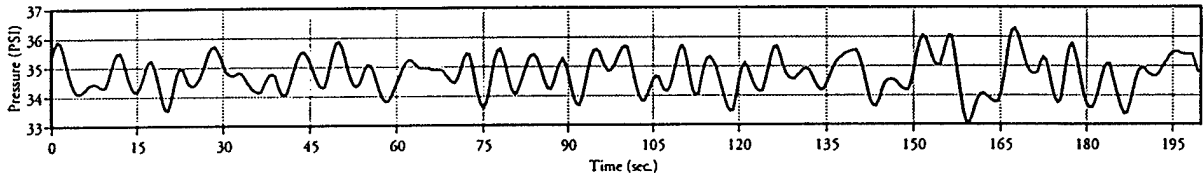
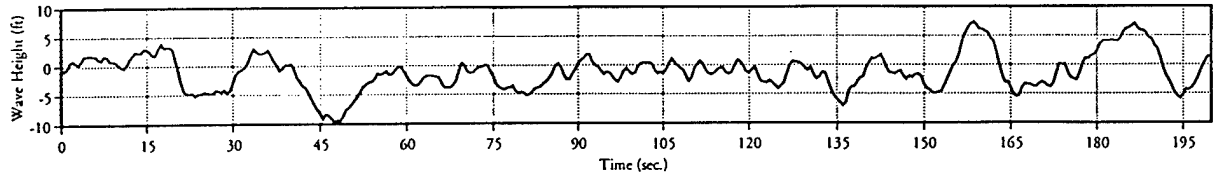



# Rq18b Environmental Data

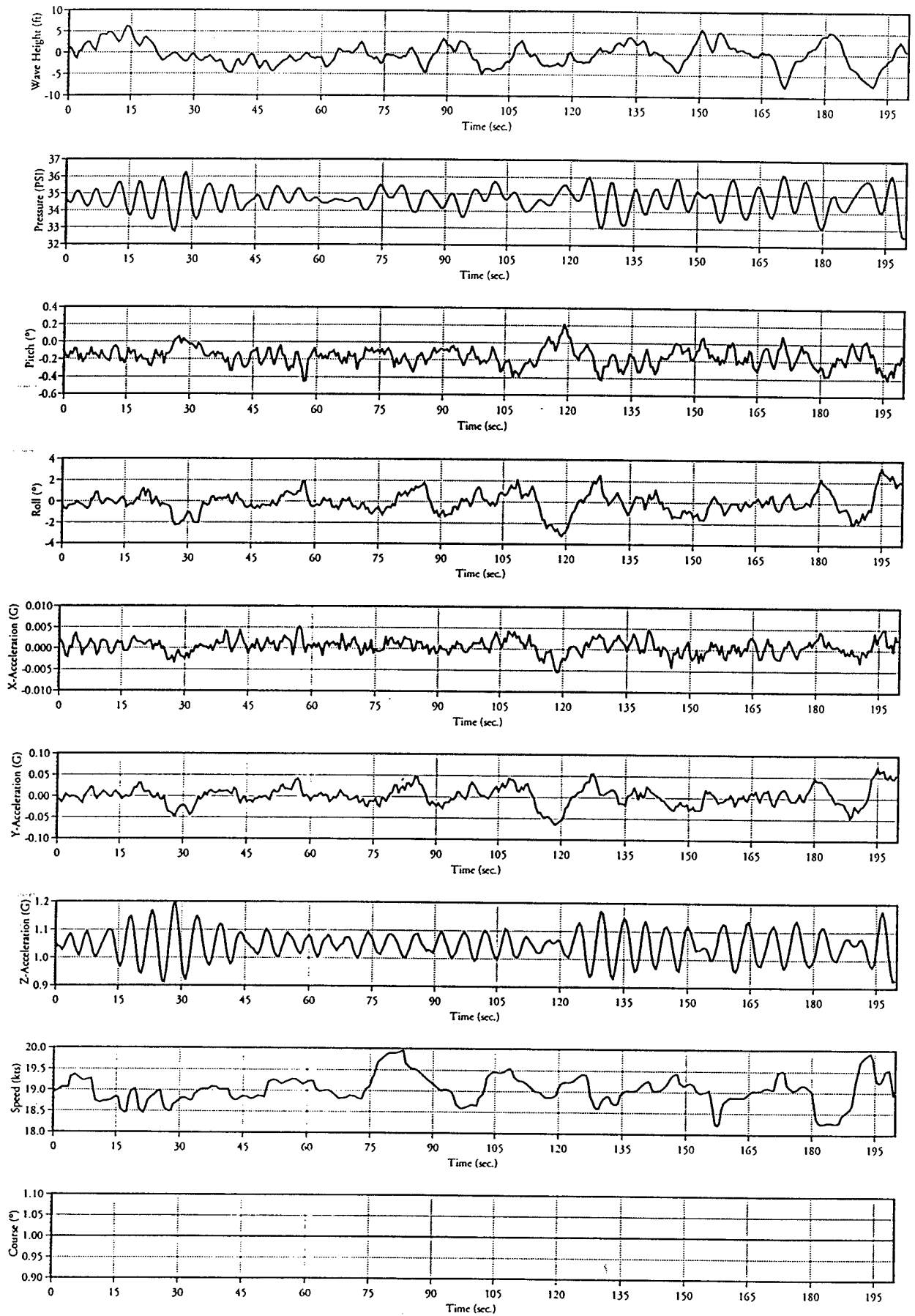

### Rq19a Environmental Data

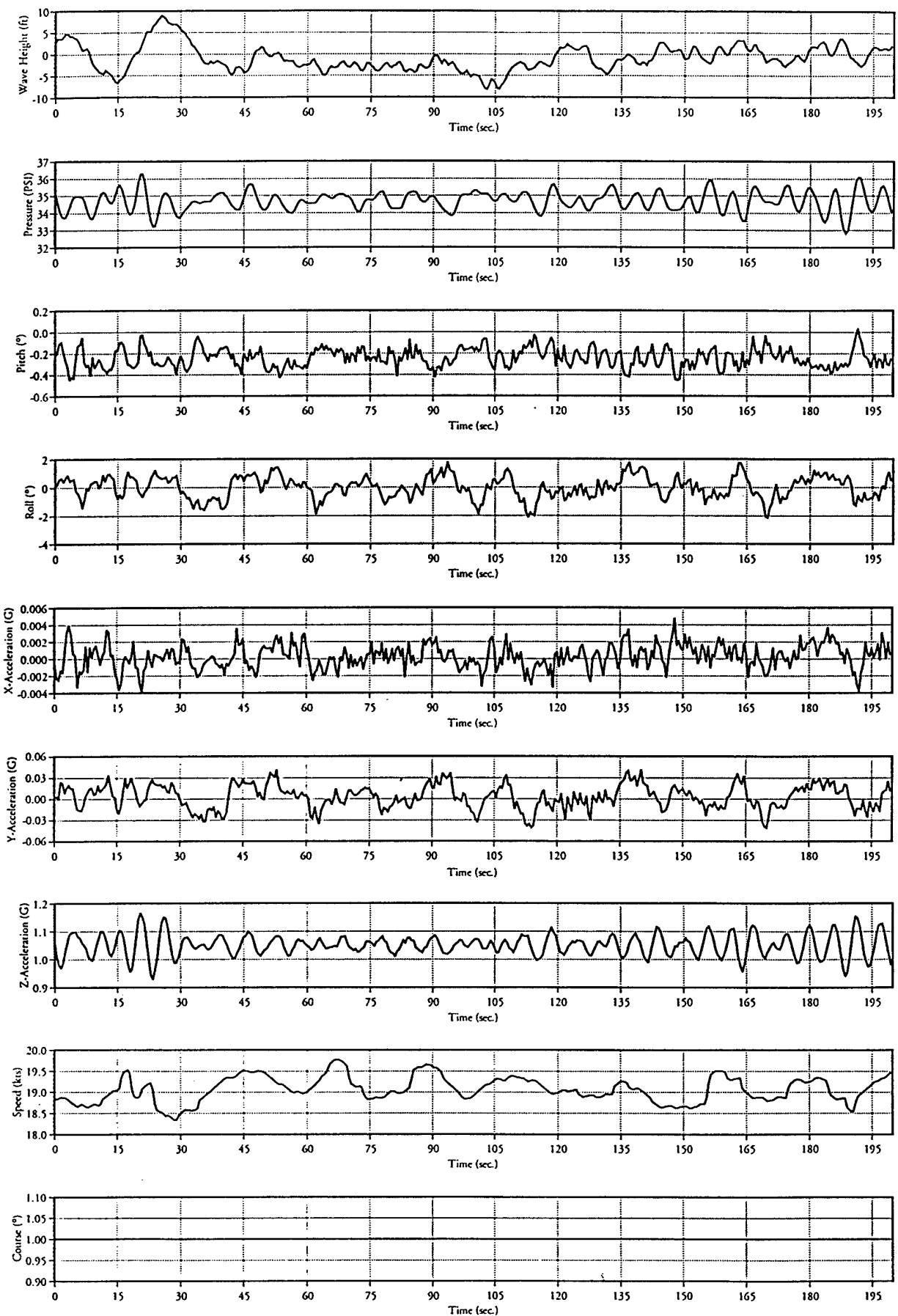

# Rq26a Environmental Data

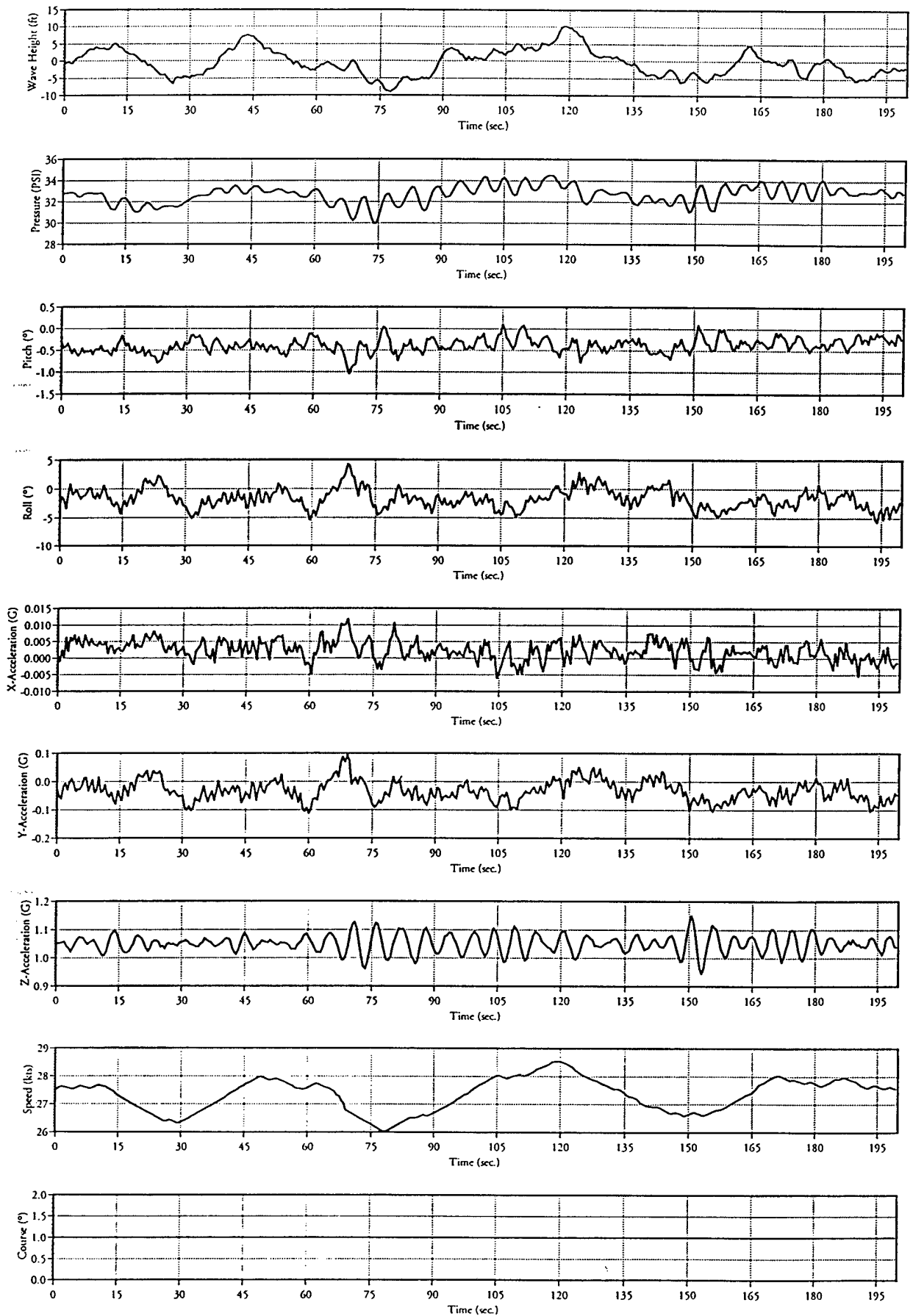

# Rq27a Environmental Data

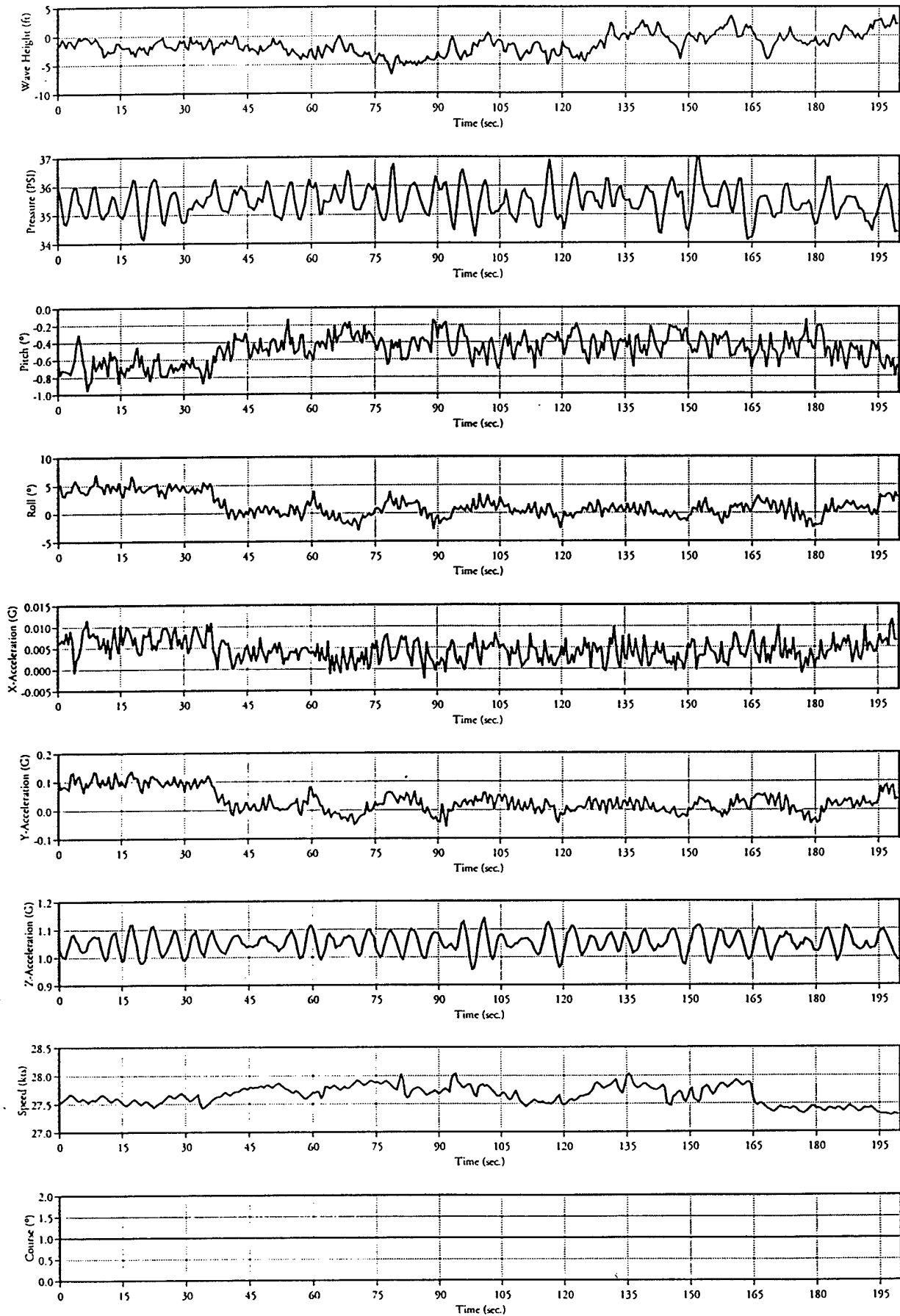

# Rq28a Environmental Data

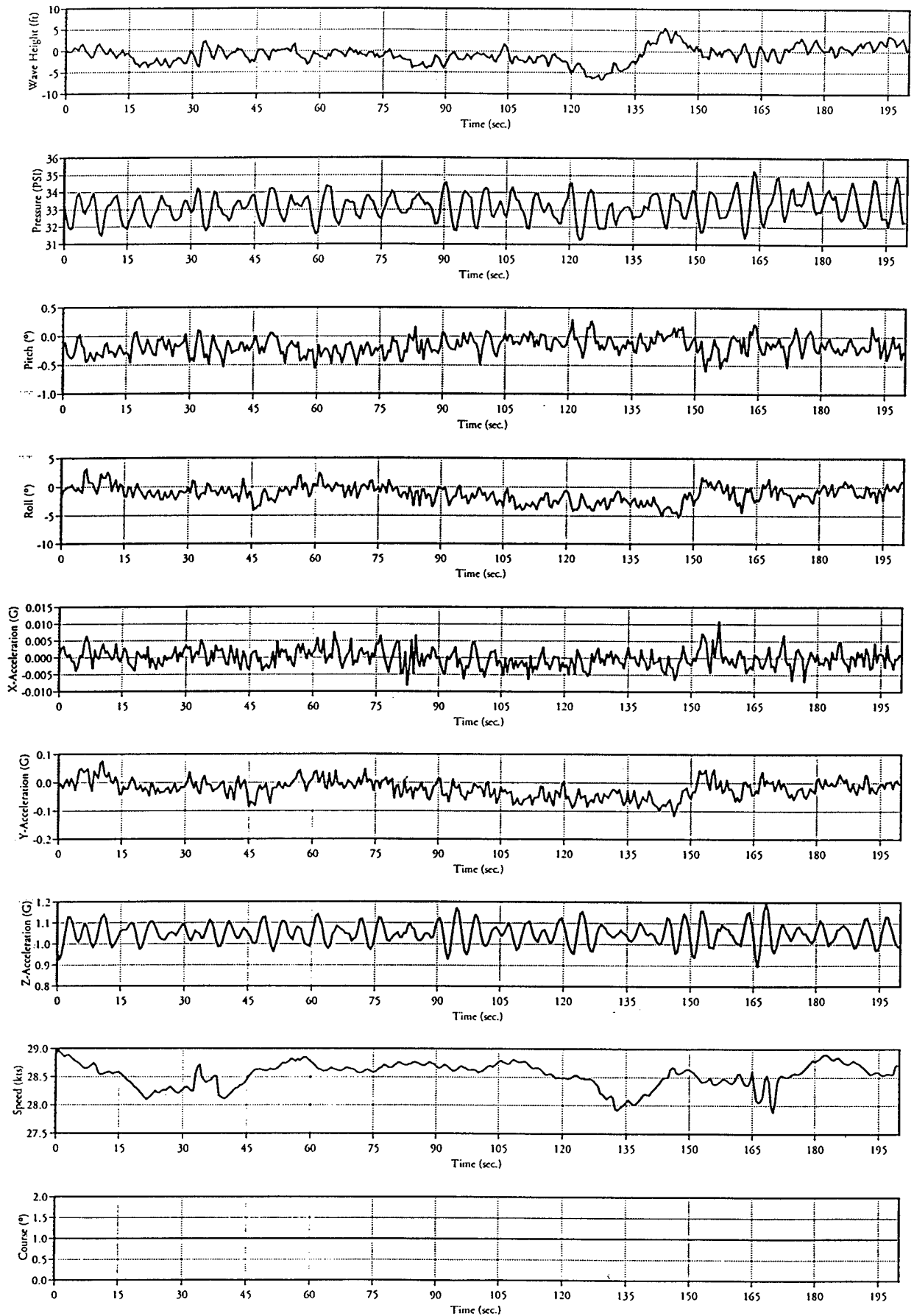

# Rq28b Environmental Data

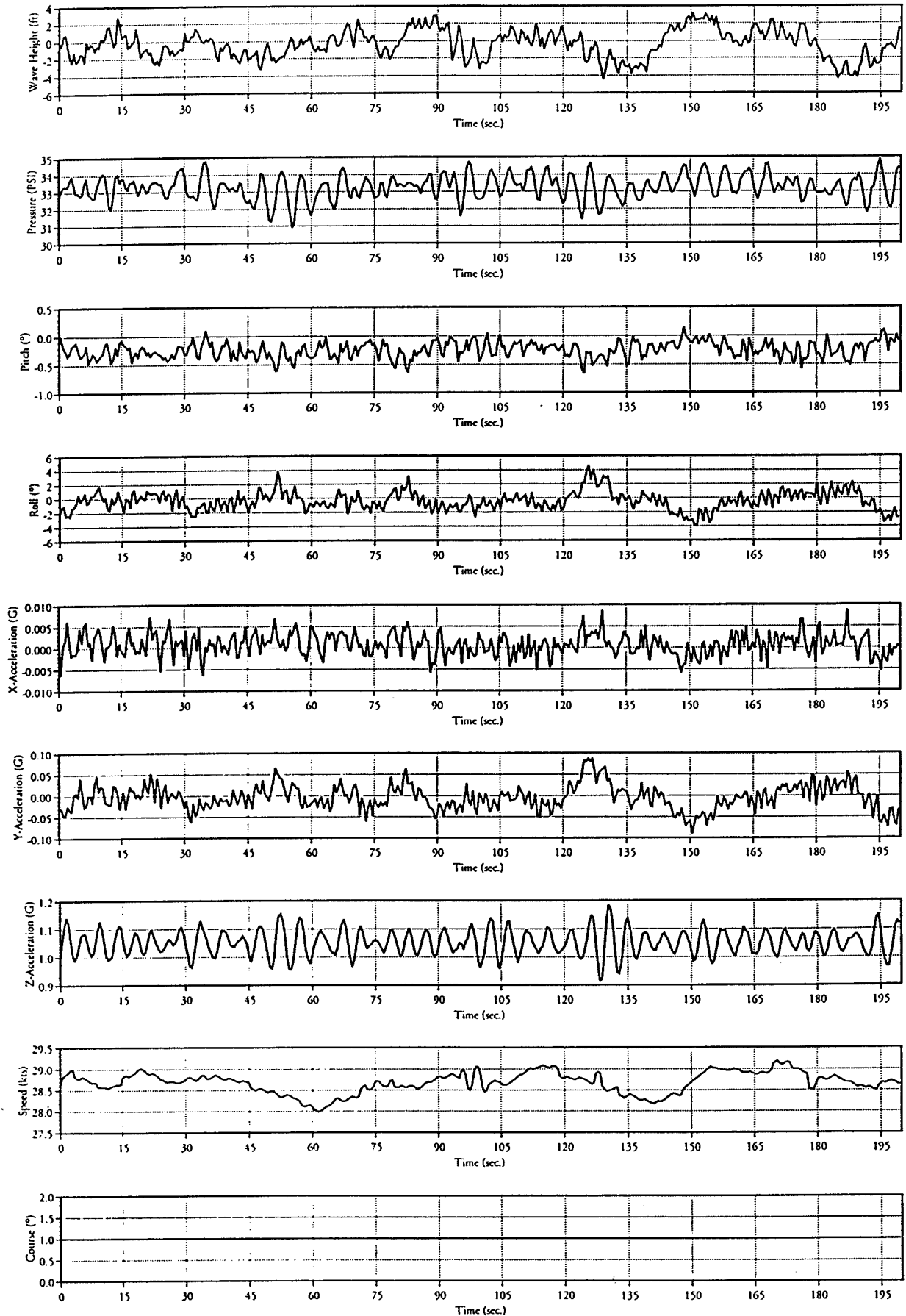

# Rq28c Environmental Data

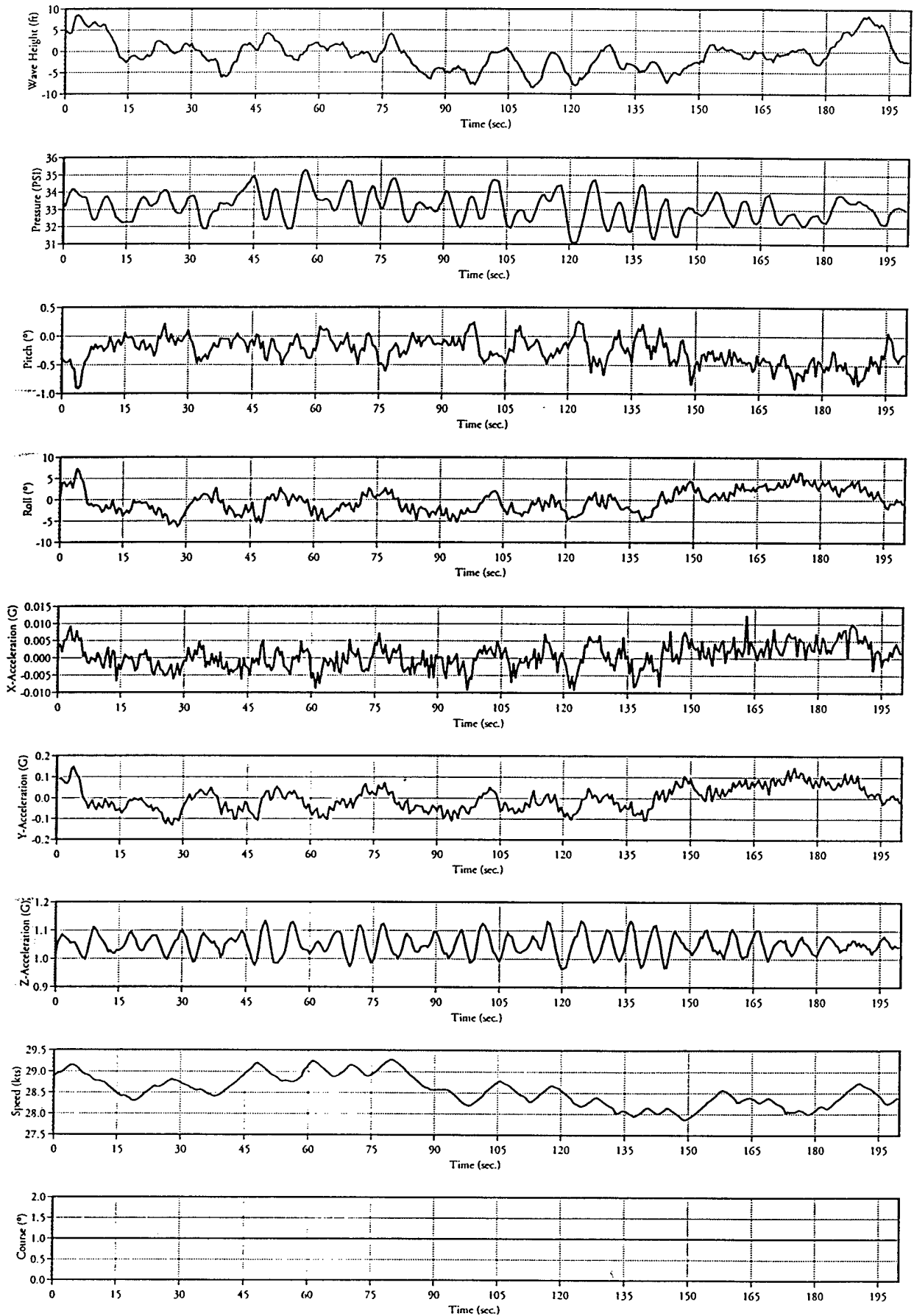

# RR15a Environmental Data

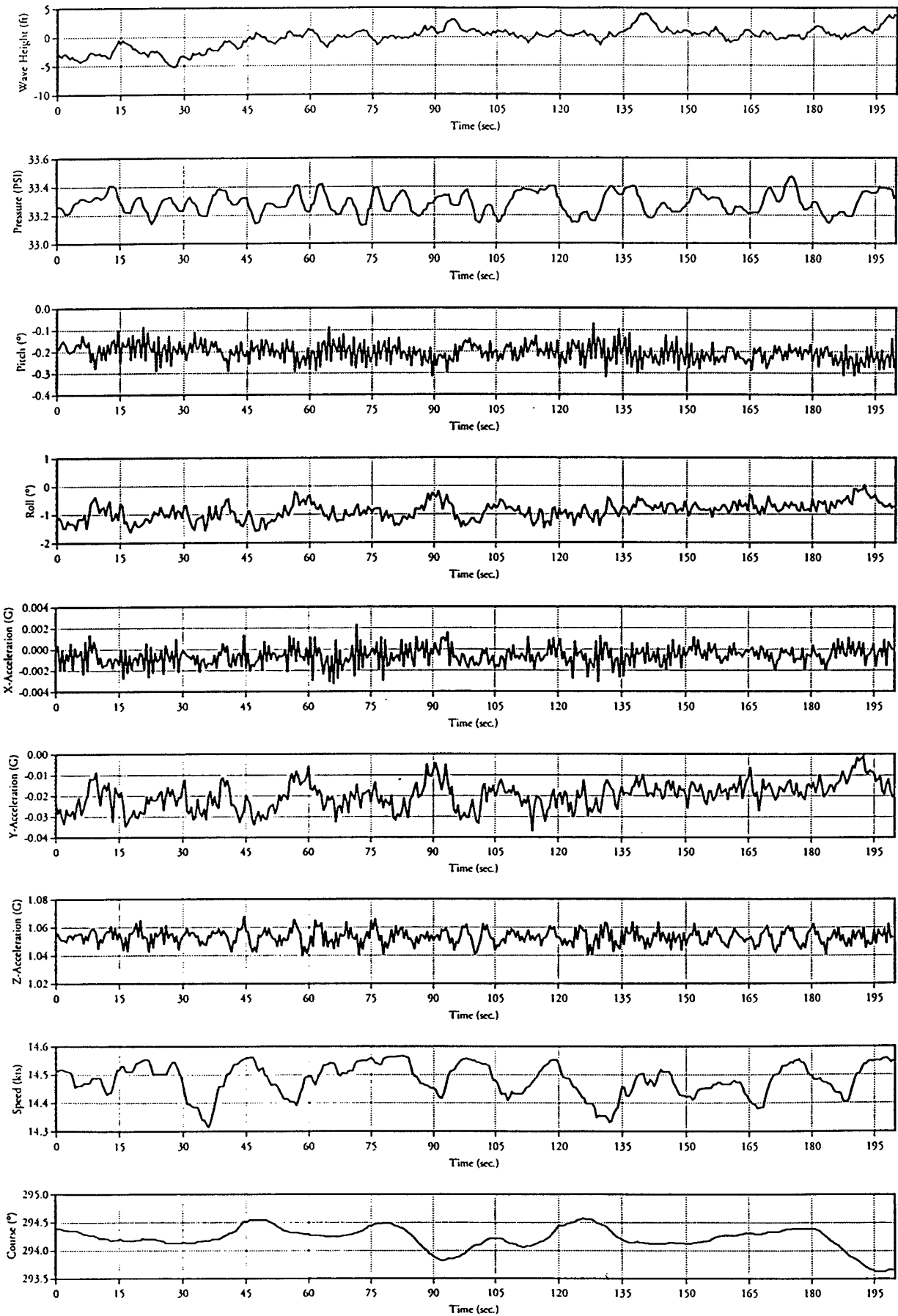



# RR19a Environmental Data

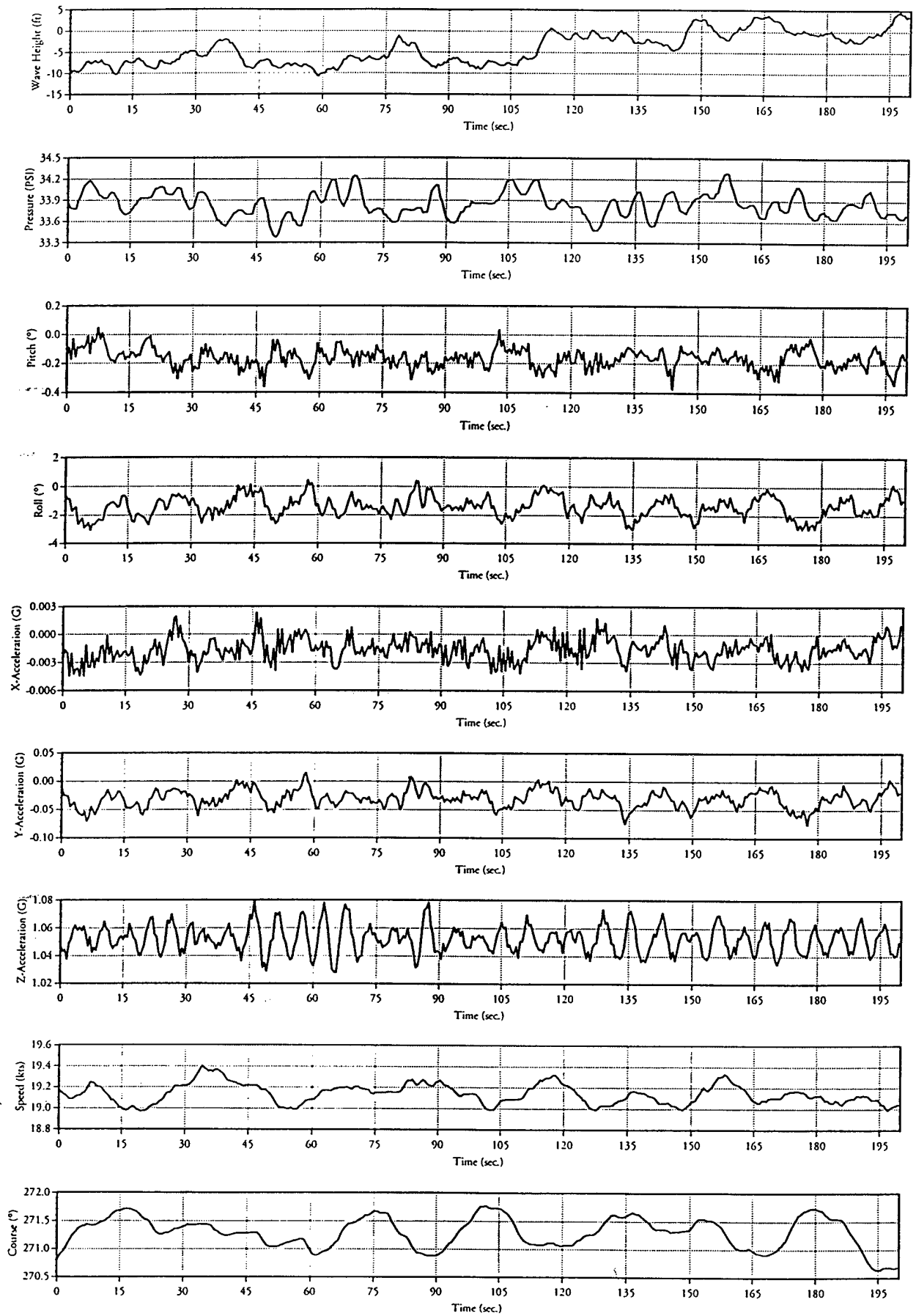

# RR19b Environmental Data

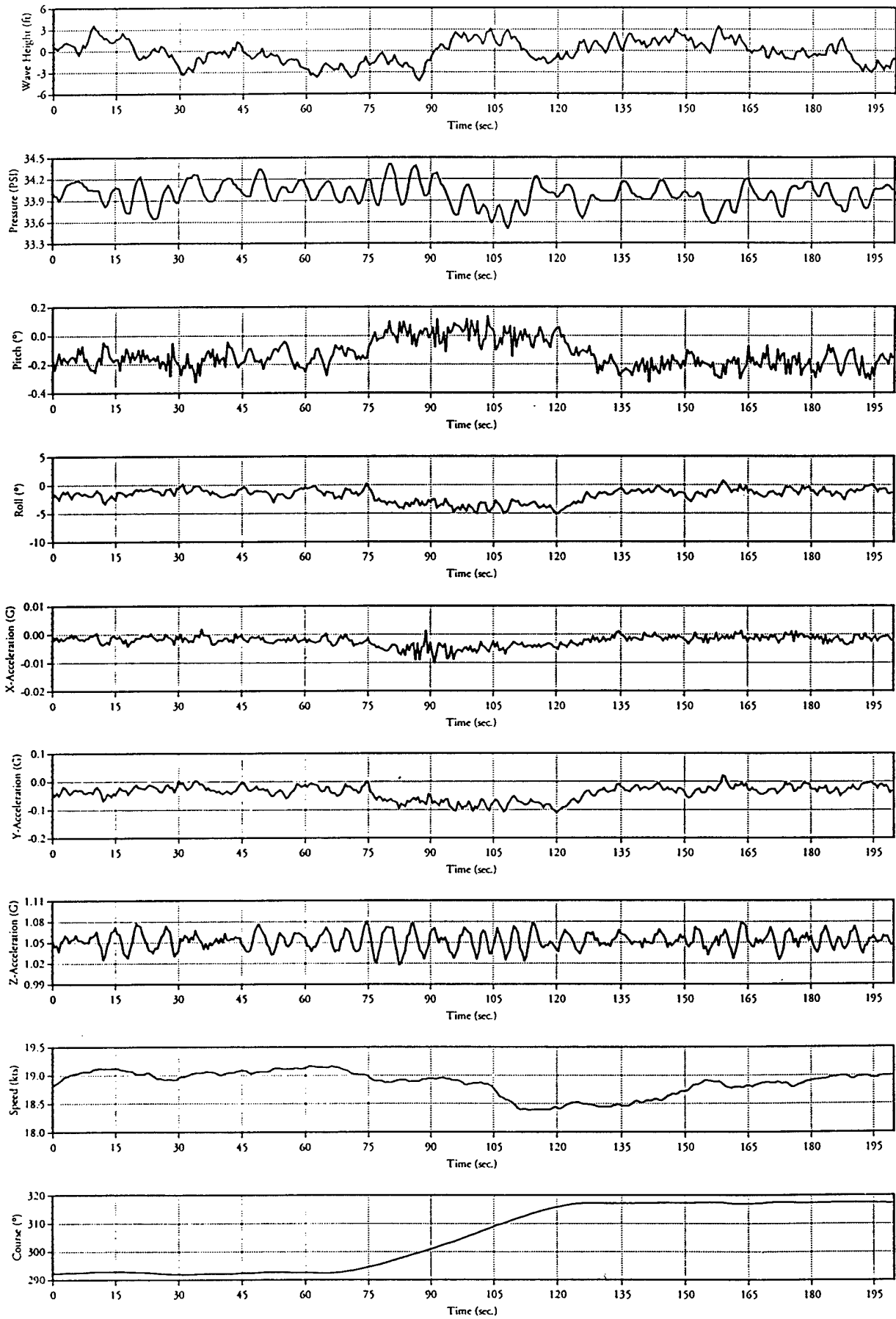

# RS17a Environmental Data

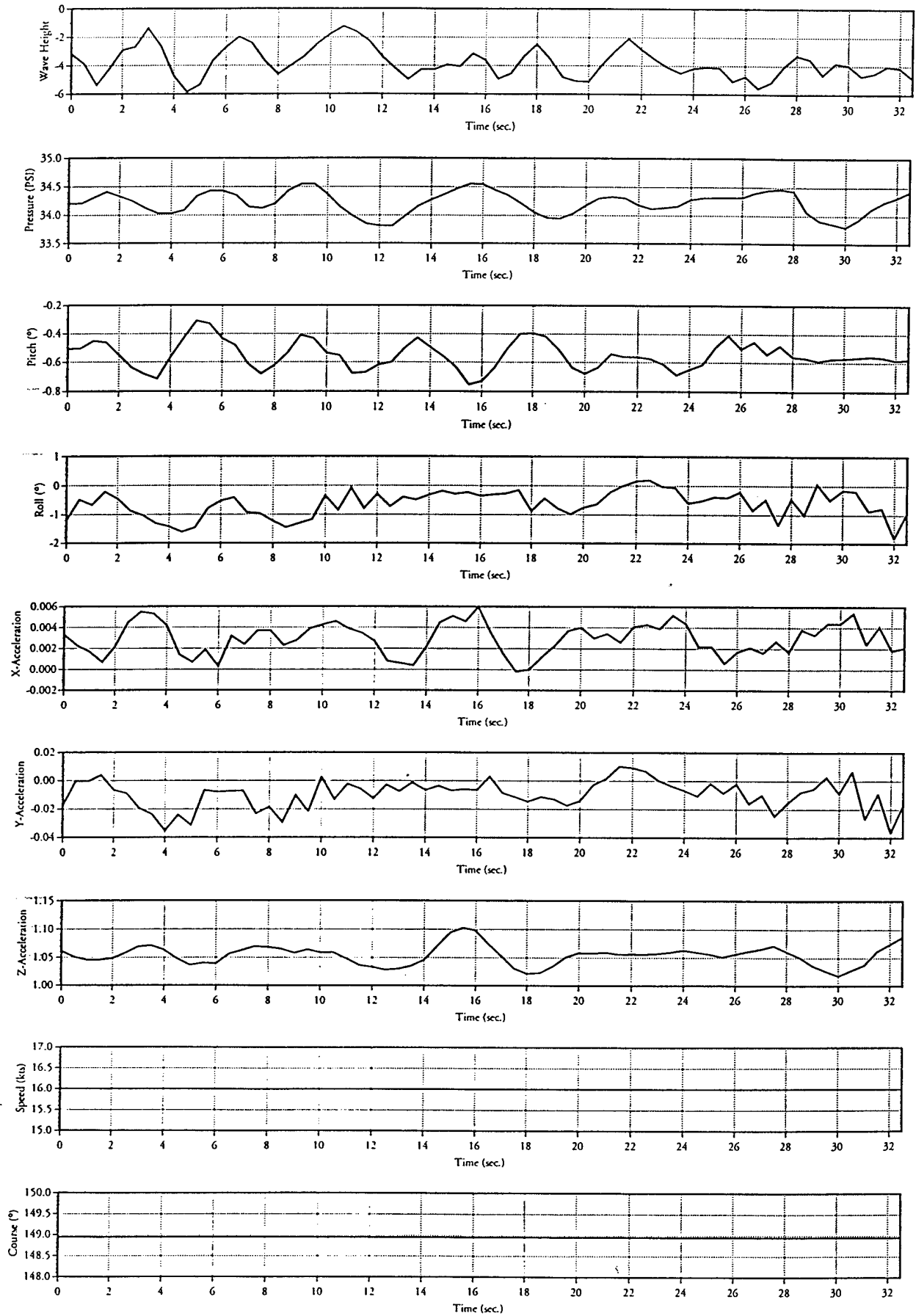

# Rt05a Environmental Data

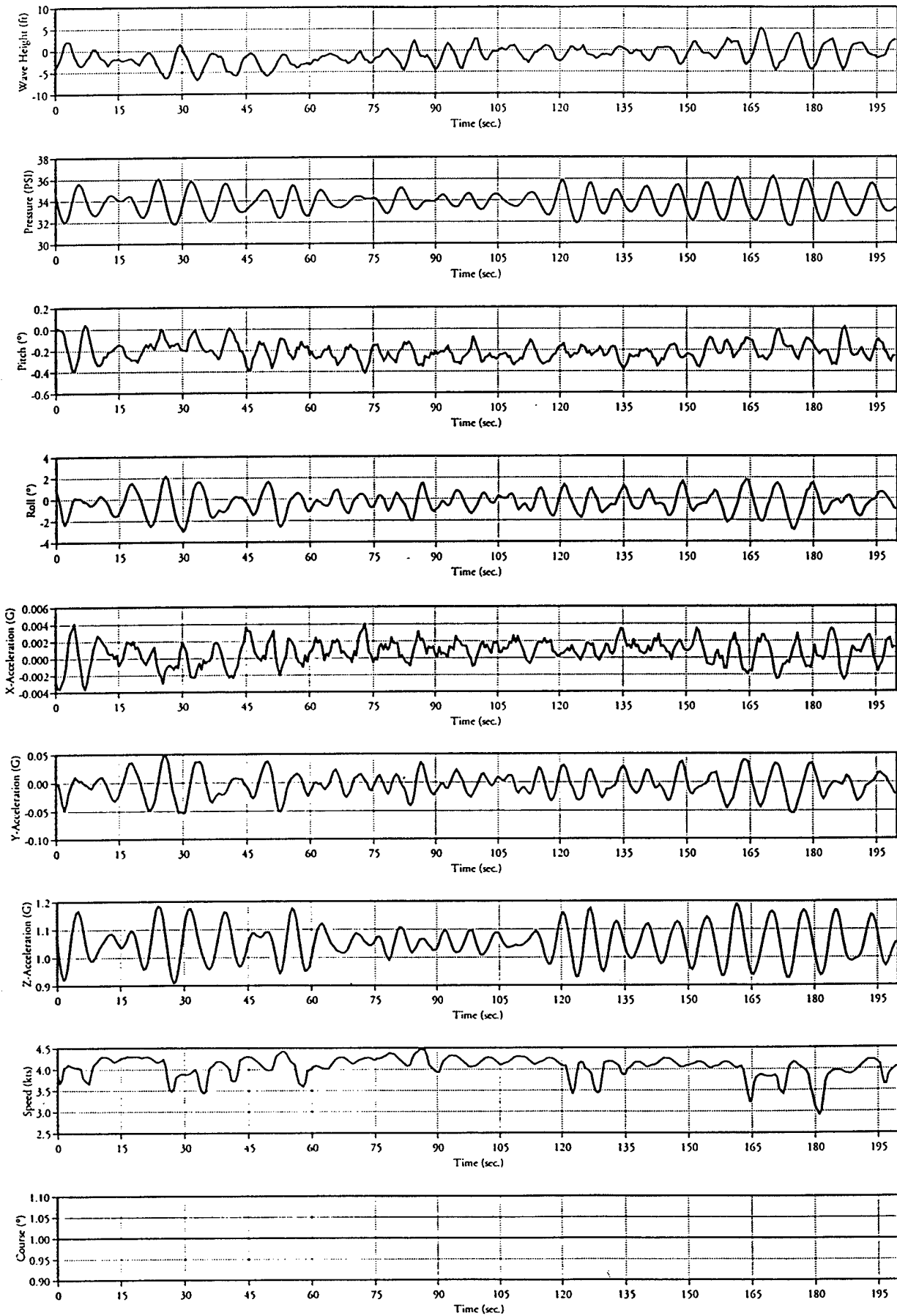

# Rt07a Environmental Data

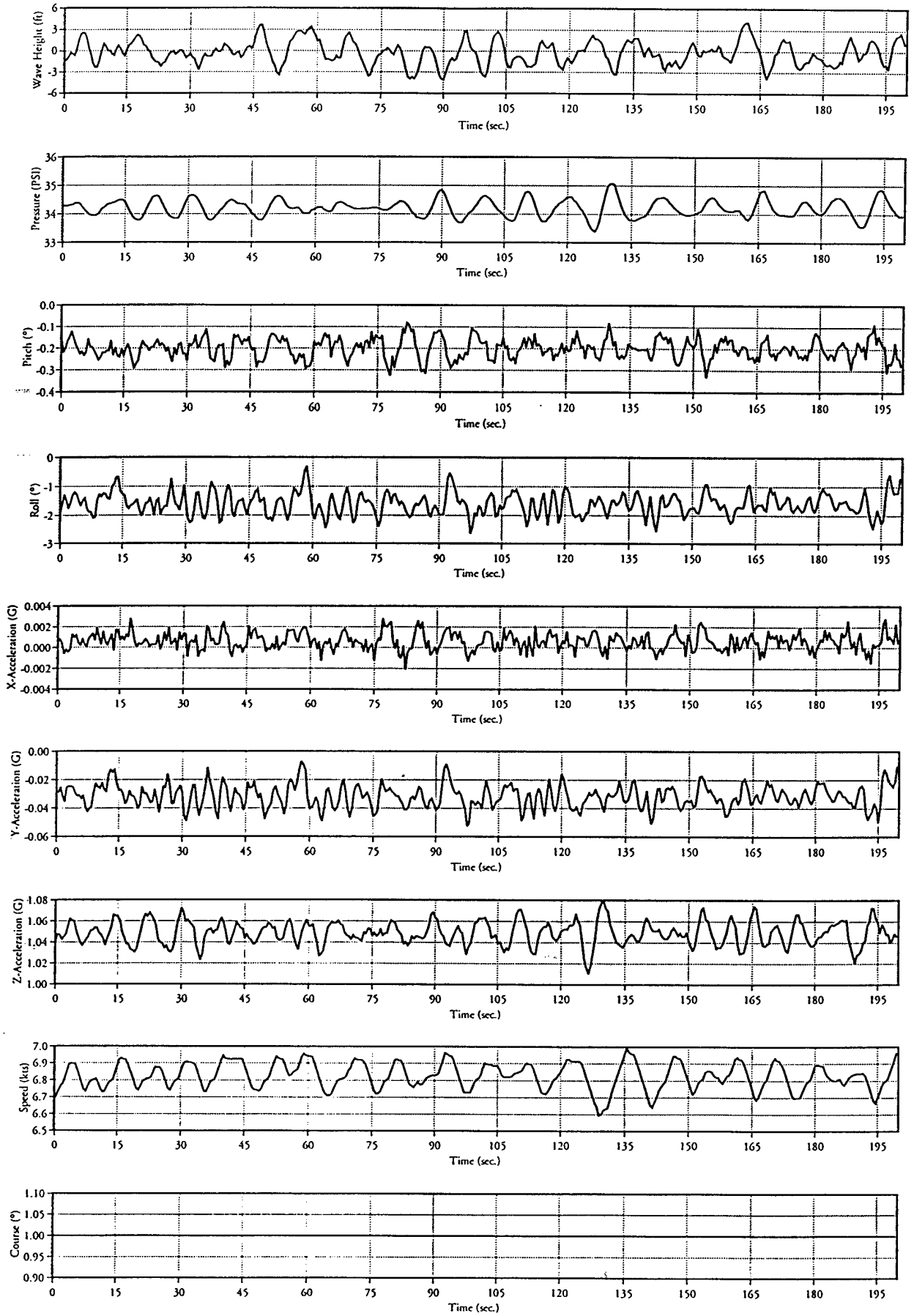

# Rt09a Environmental Data

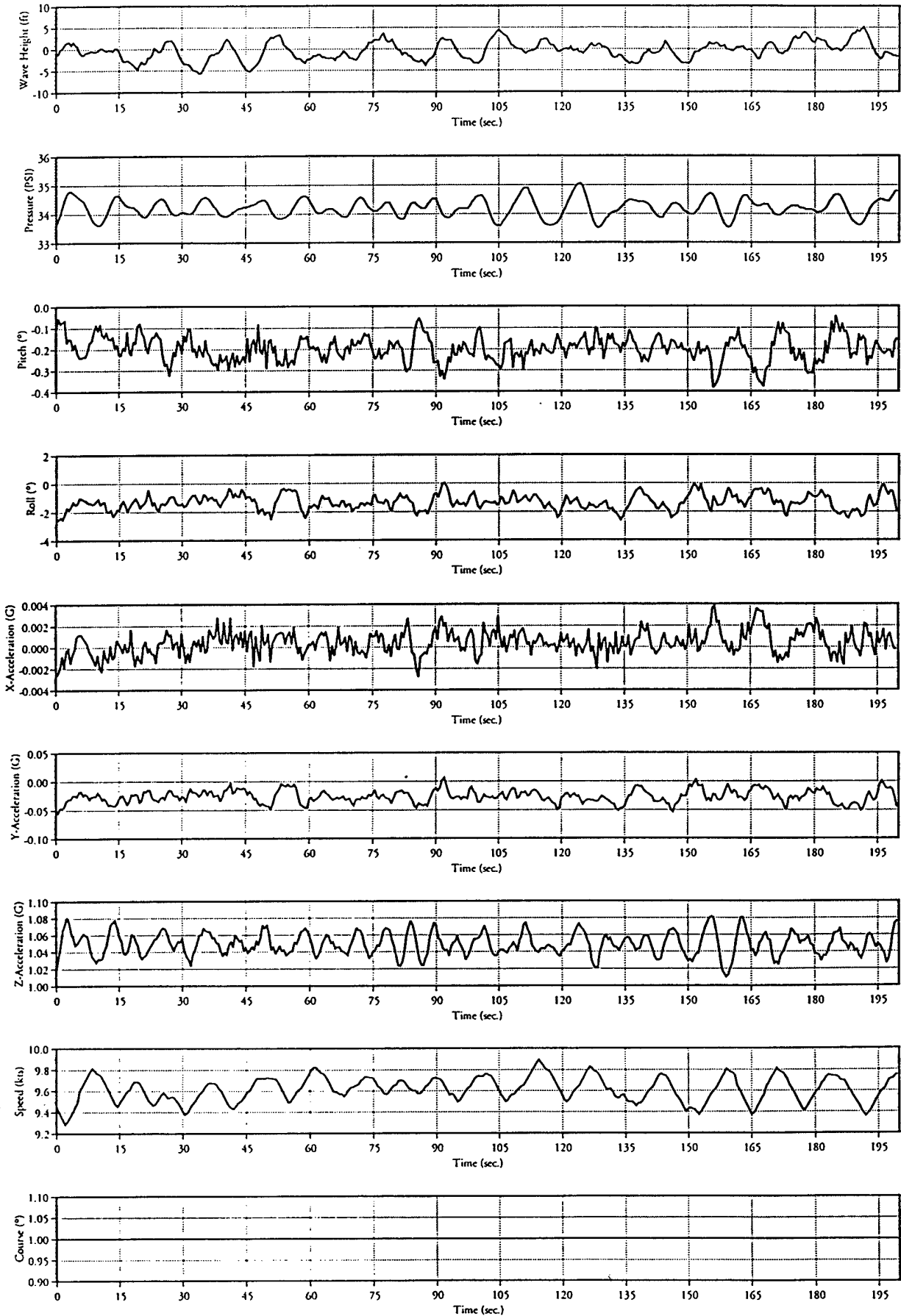

# Rt09b Environmental Data

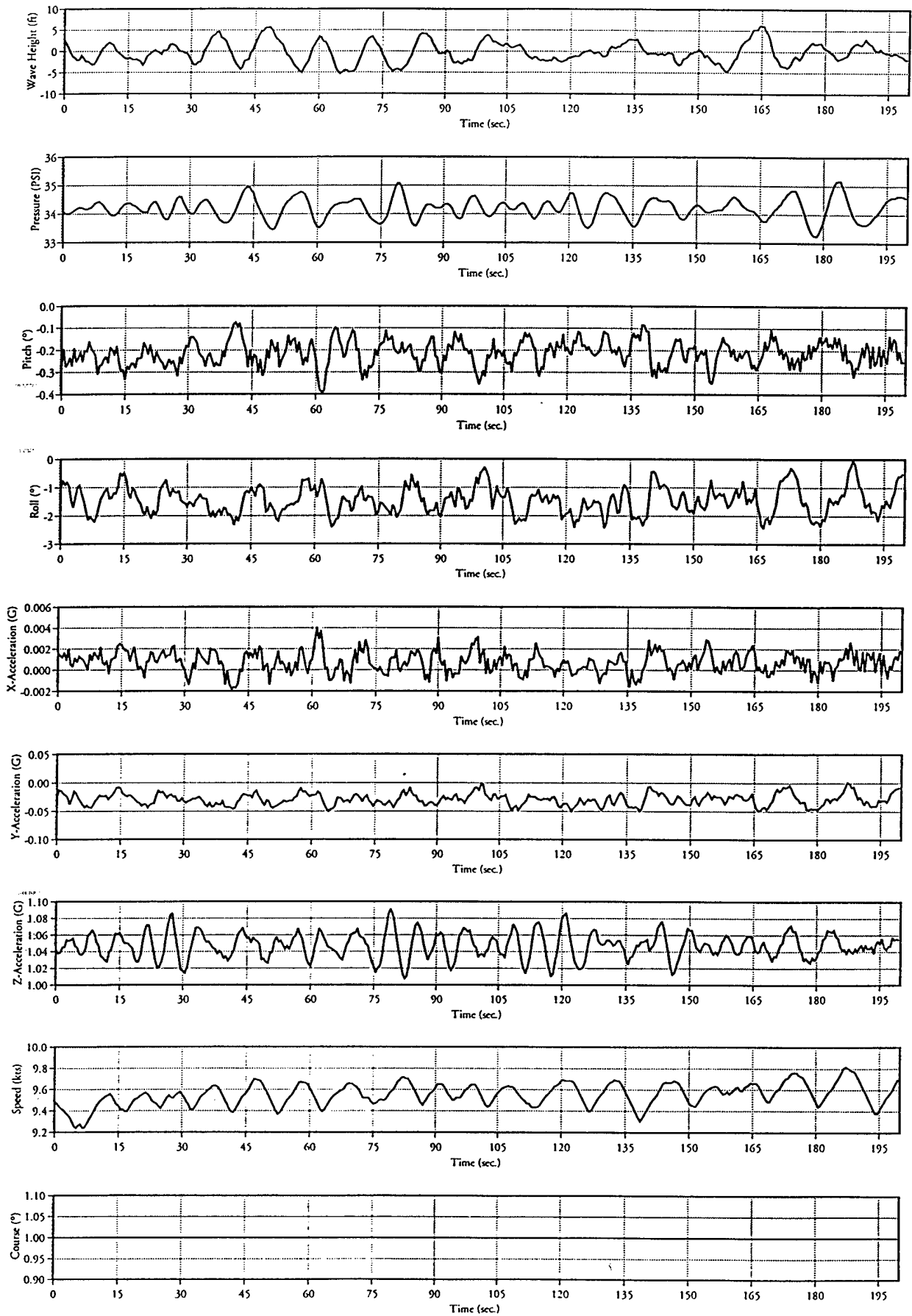

# Rt12a Environmental Data

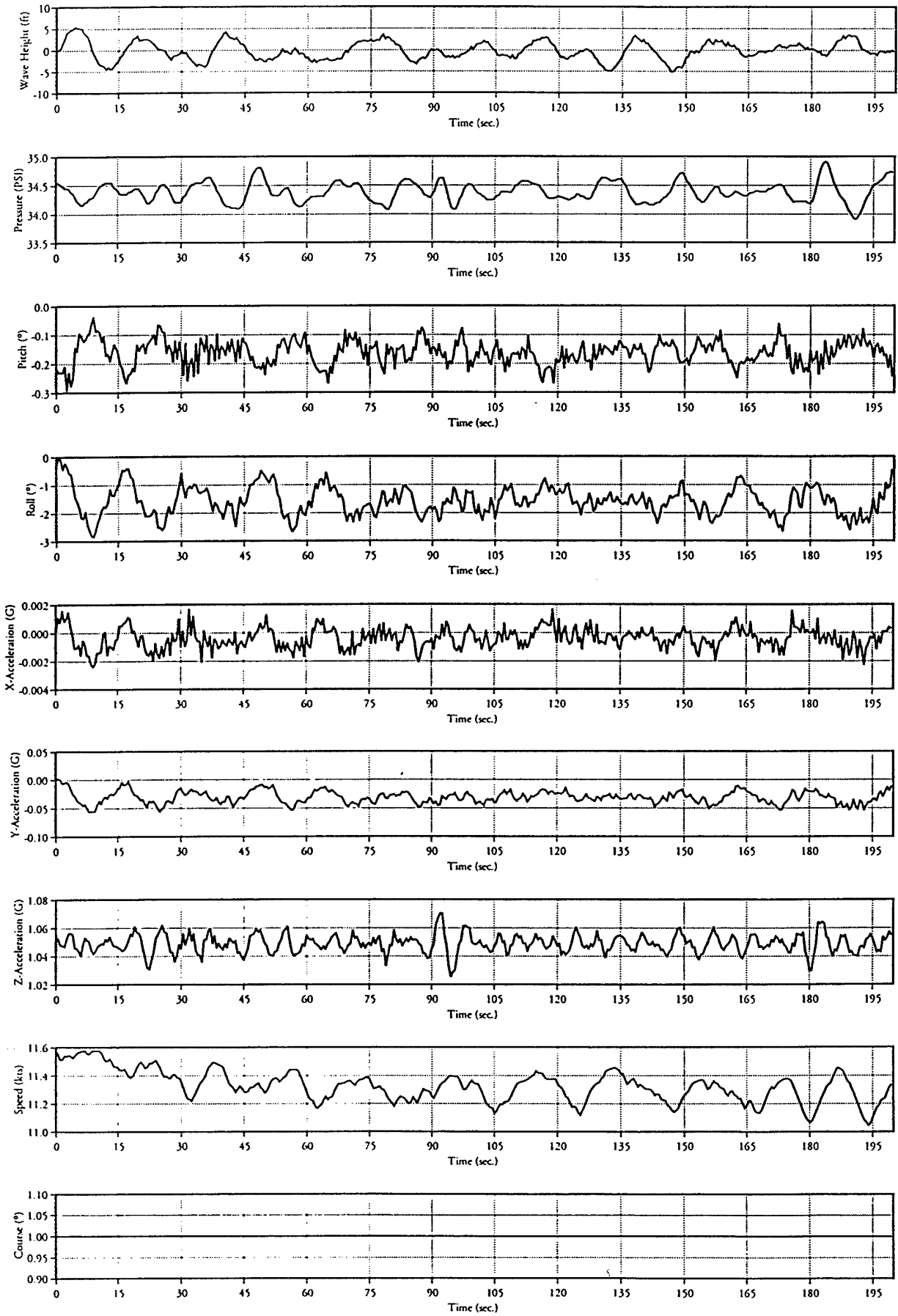



# Rt12b Environmental Data

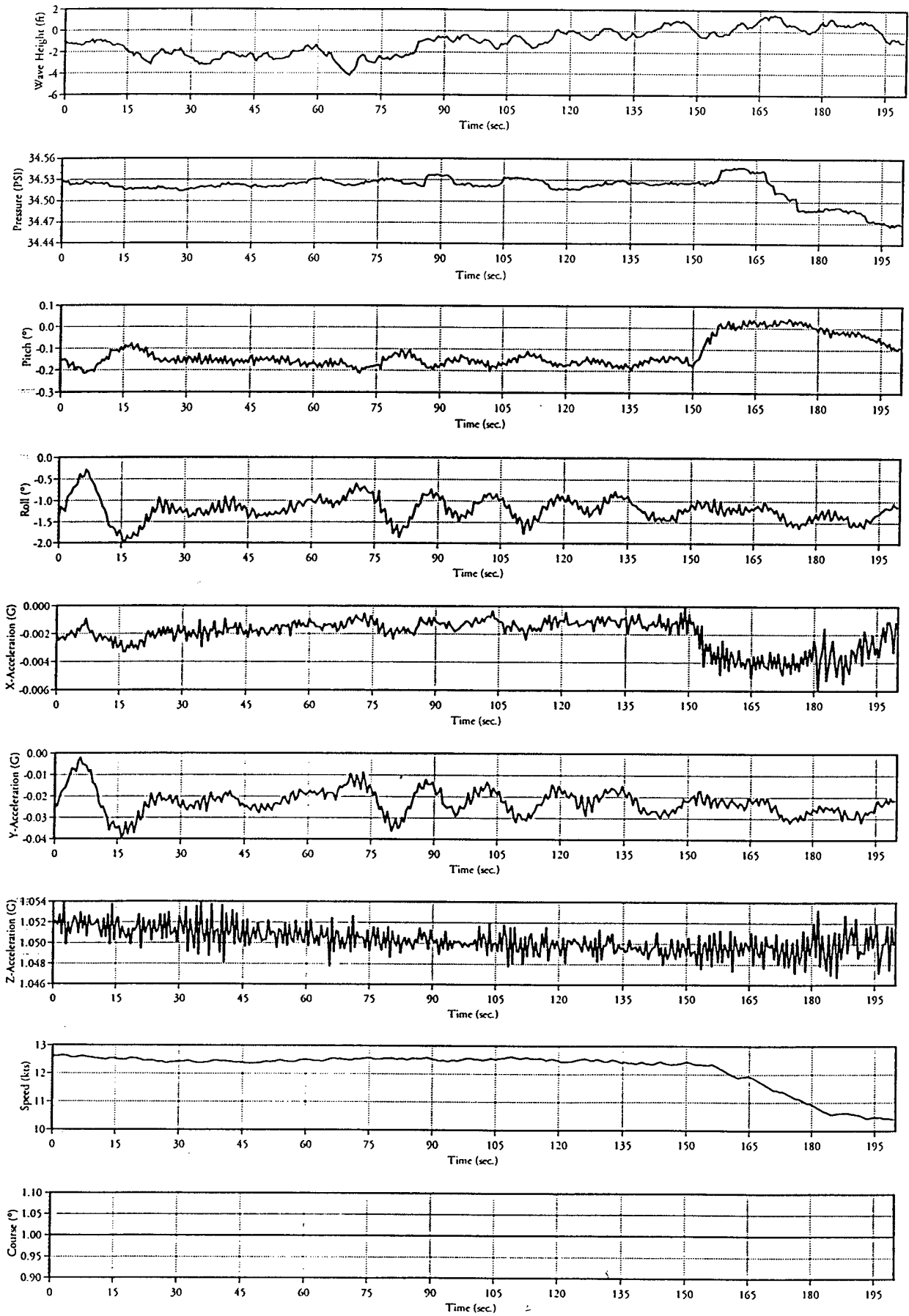

rt14a Environmental Data

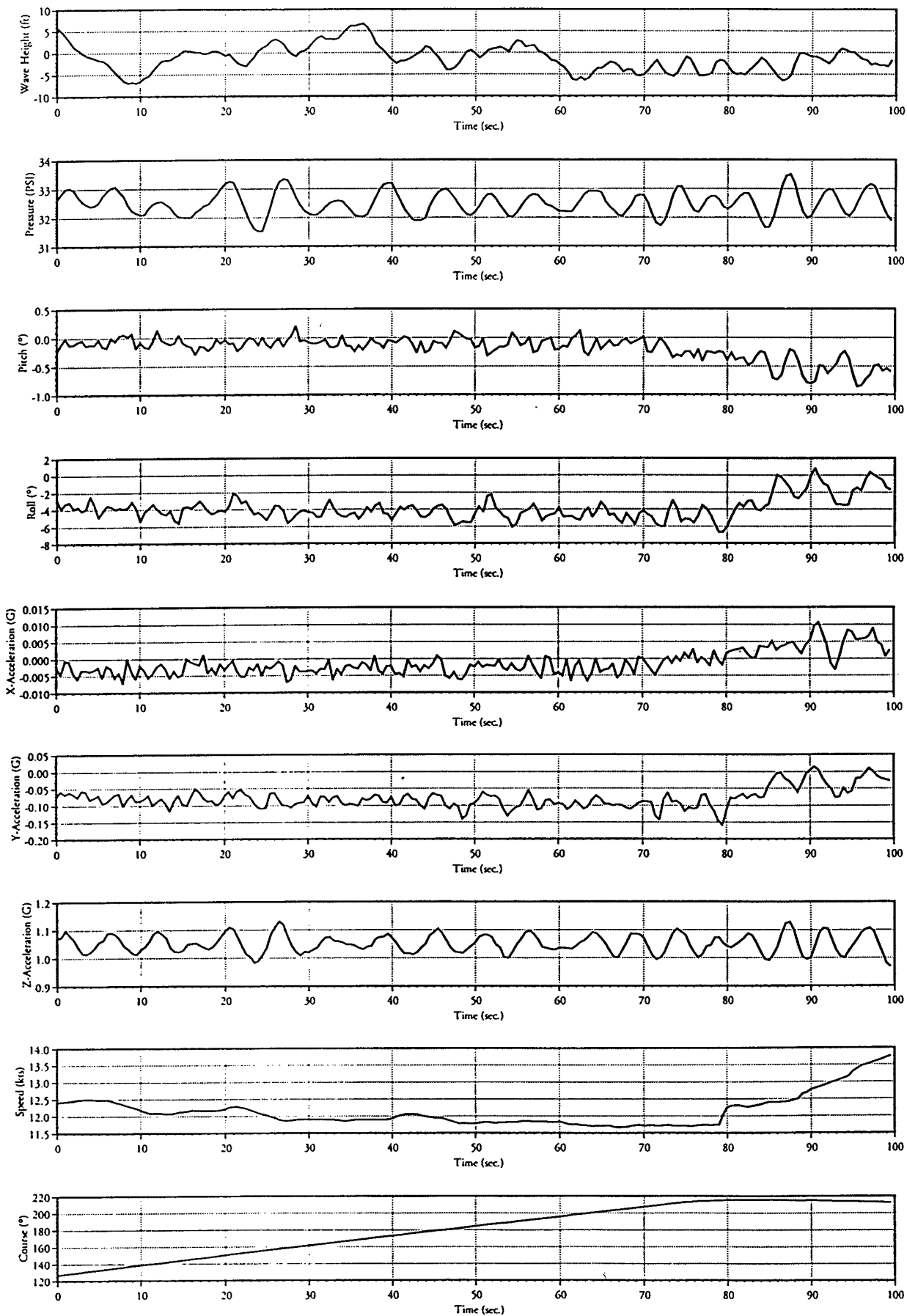

rt15b Environmental Data

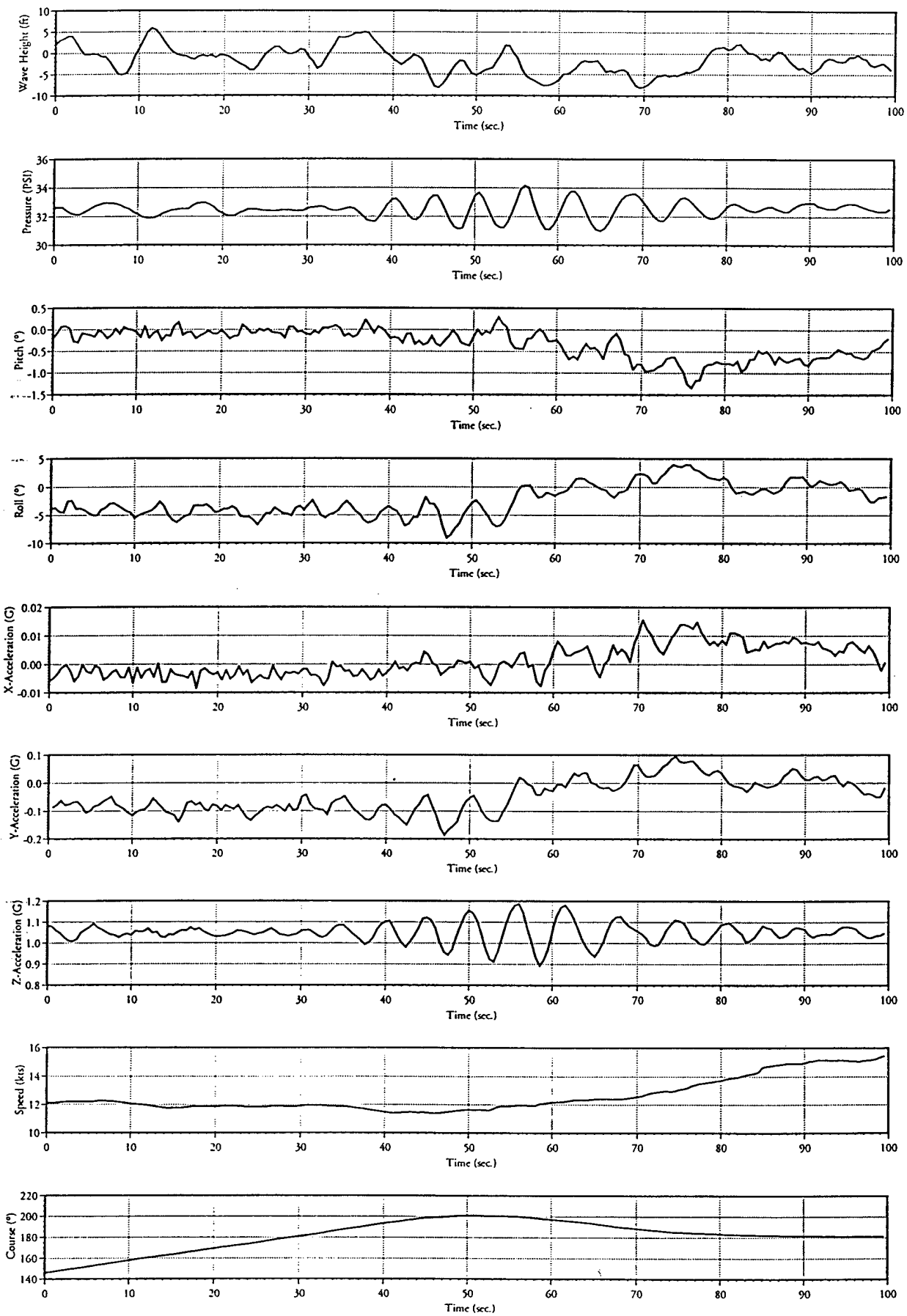

# Rt16a Environmental Data

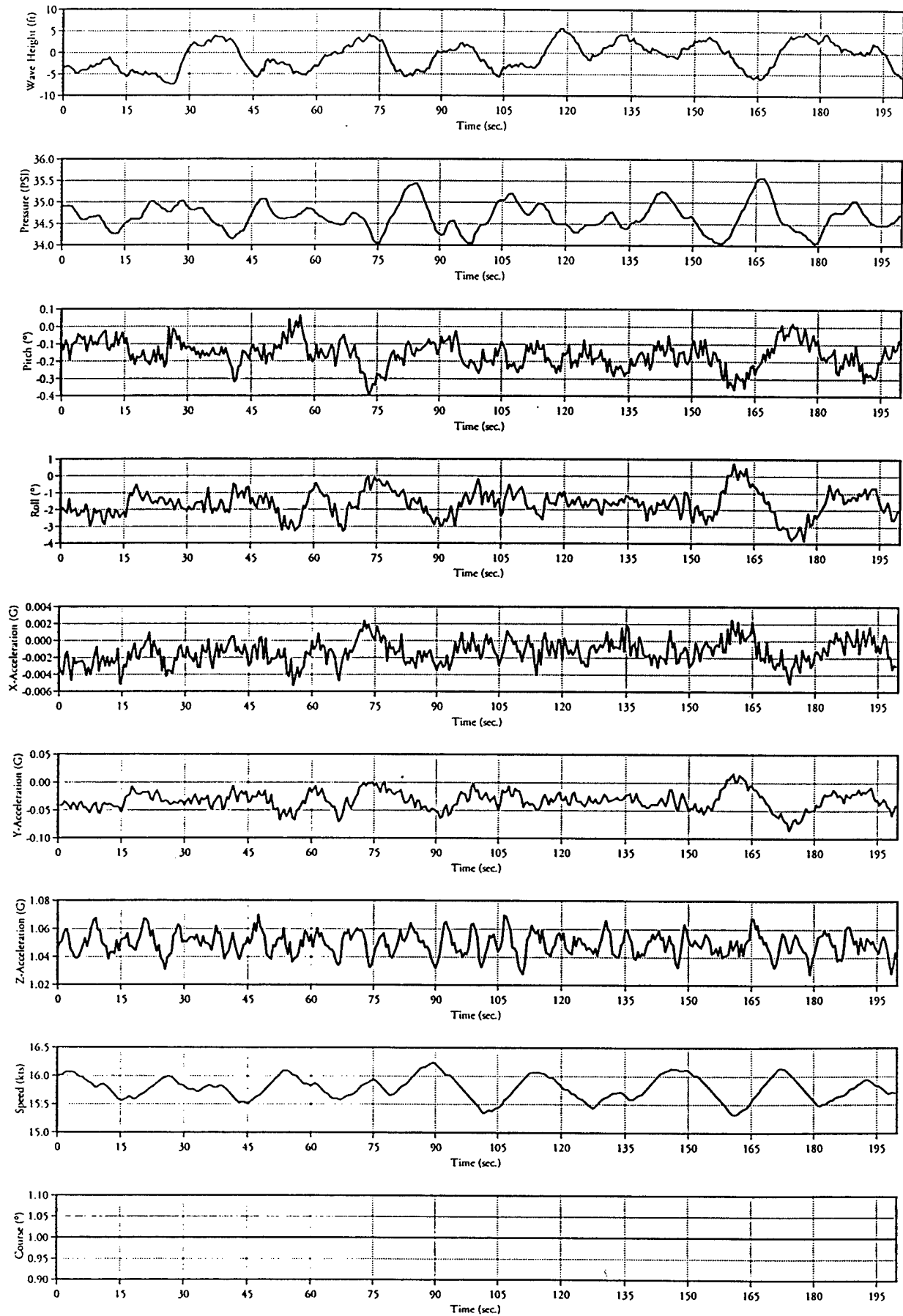

# Rt17a Environmental Data

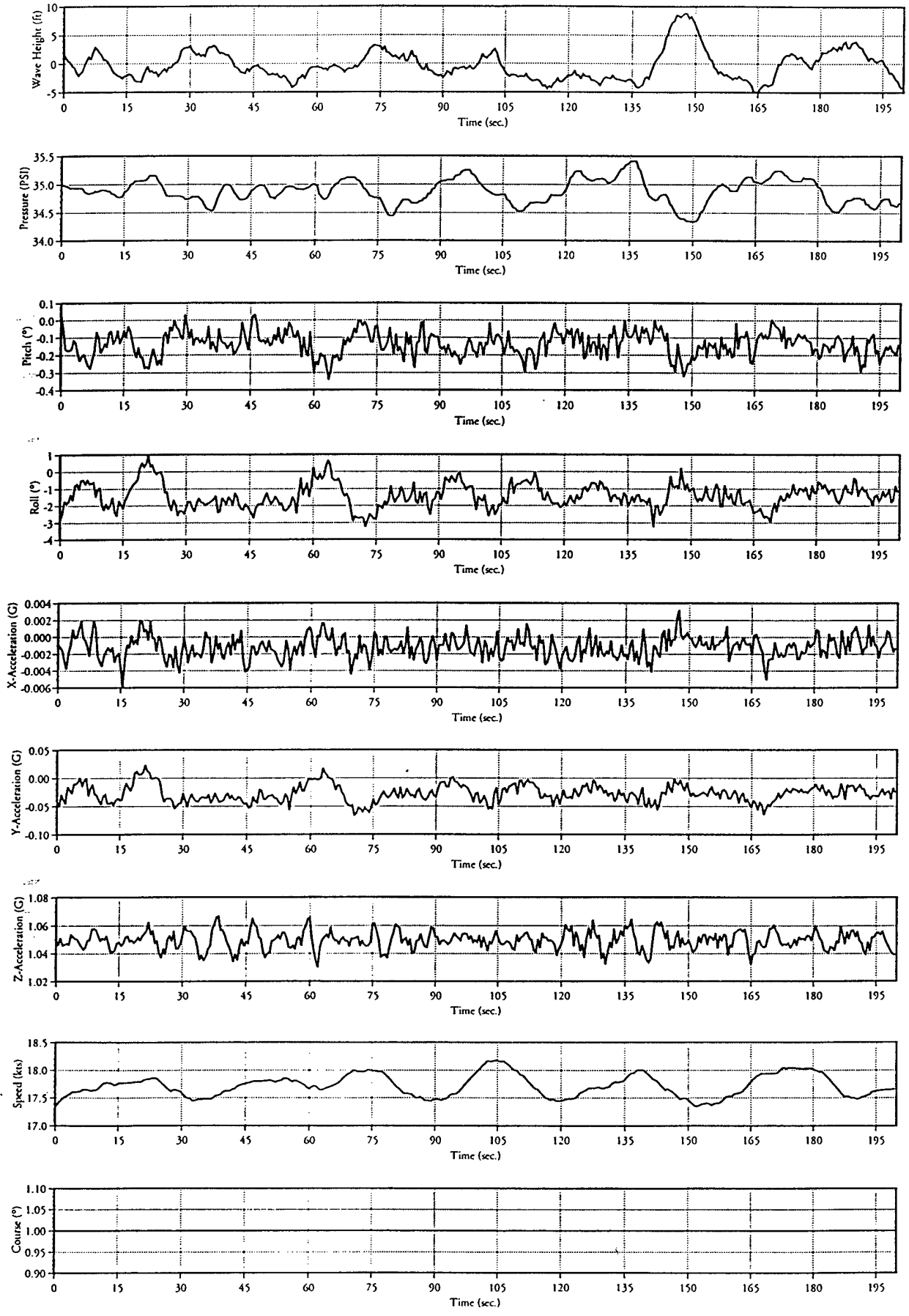

# RT18A Environmental Data

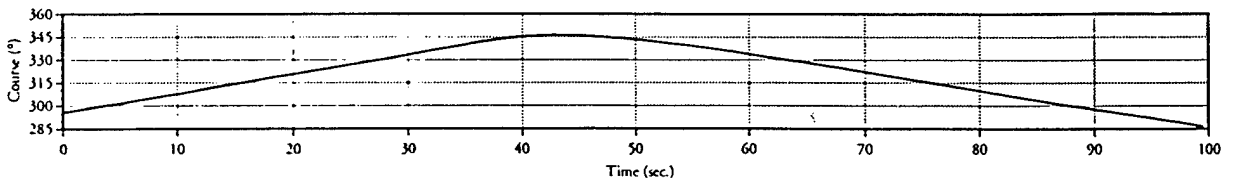
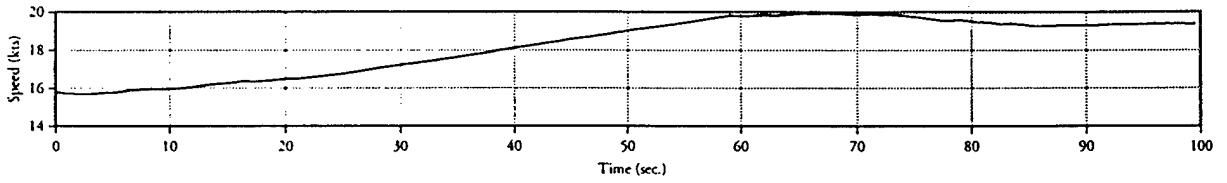
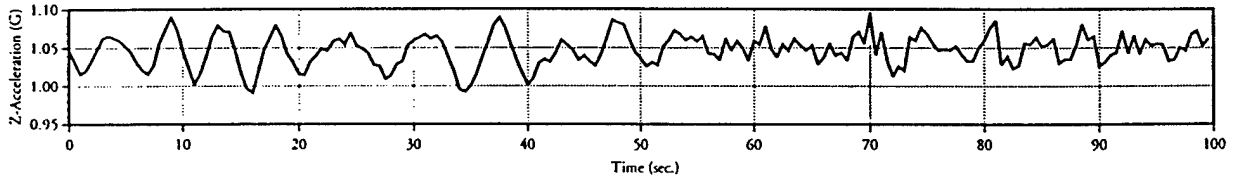
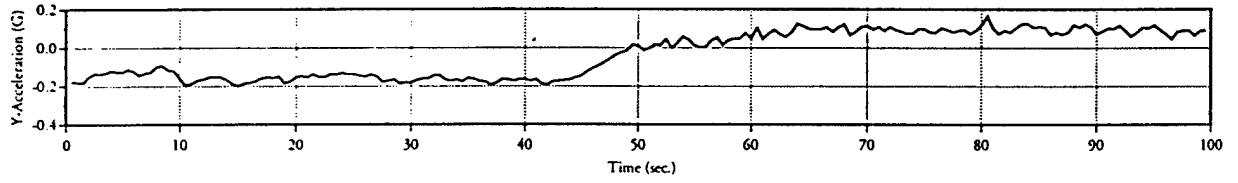
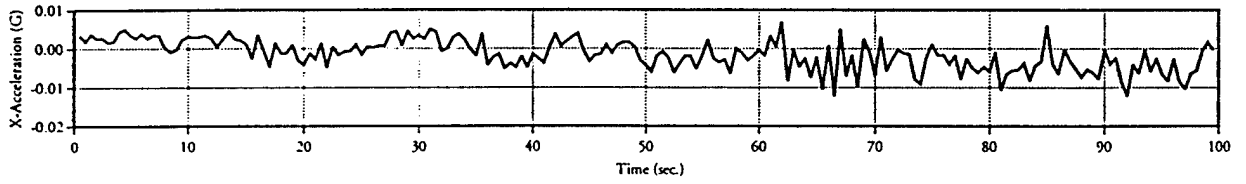
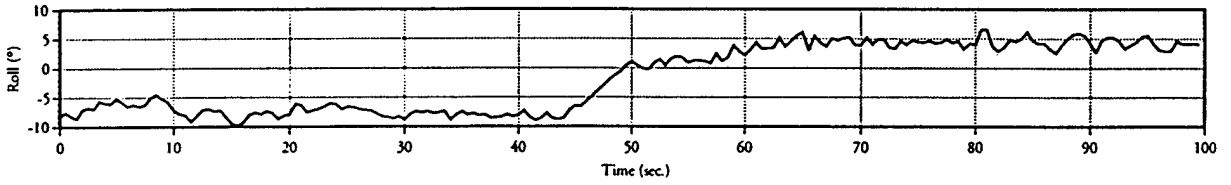
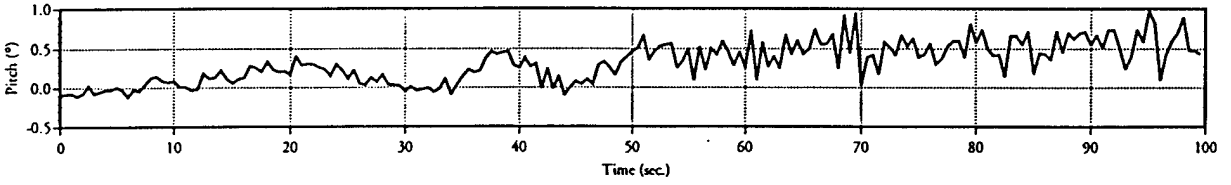
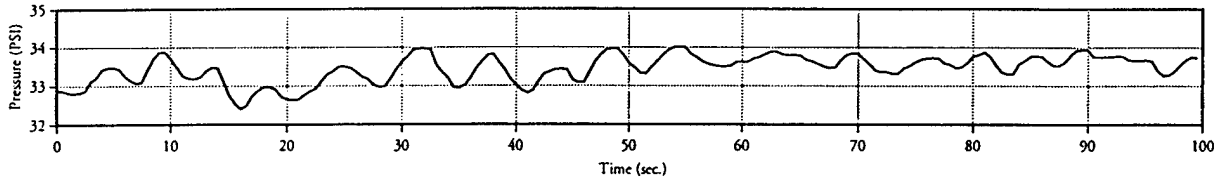
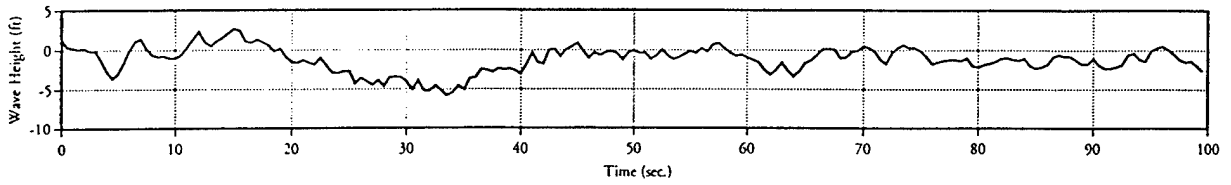

# RU17a Environmental Data

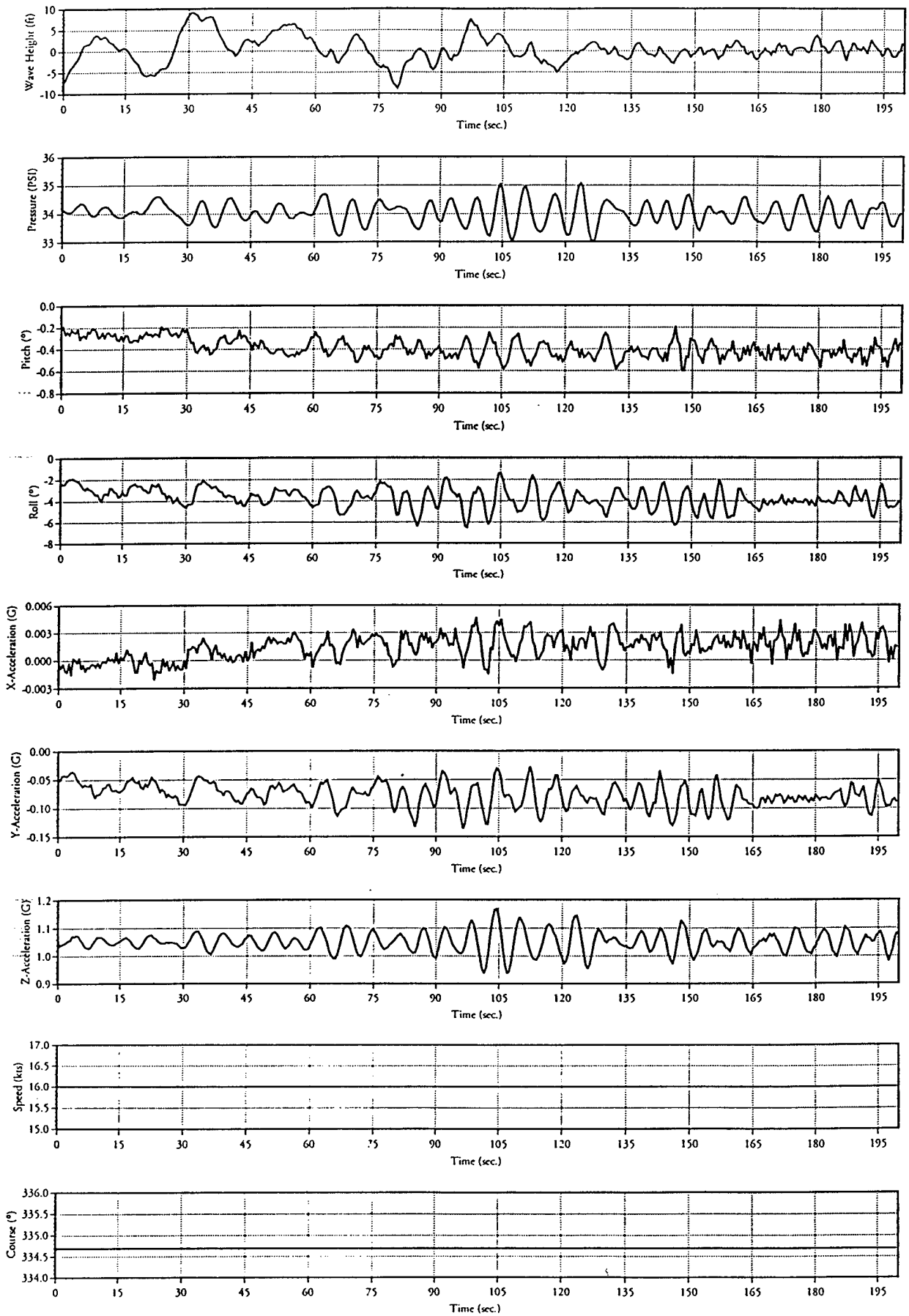

# RU20a Environmental Data

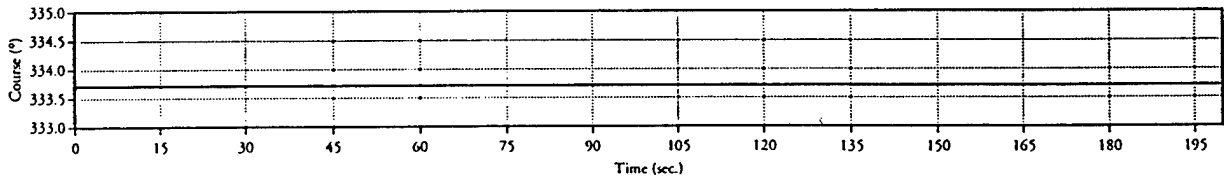
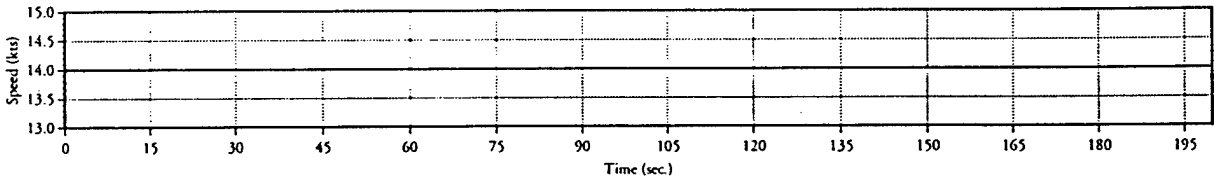
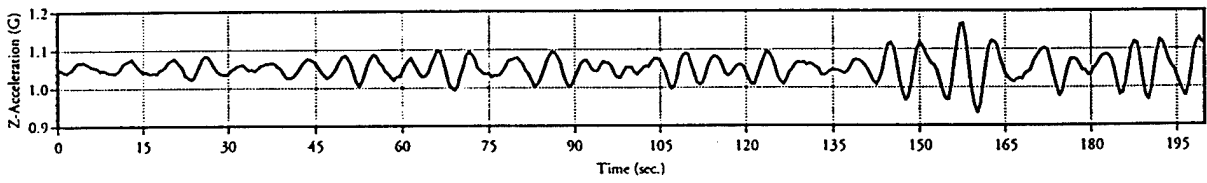
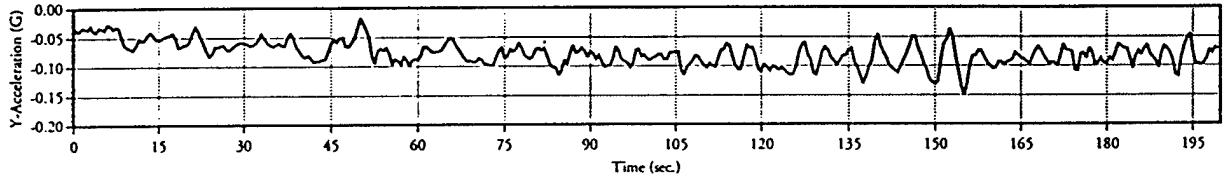
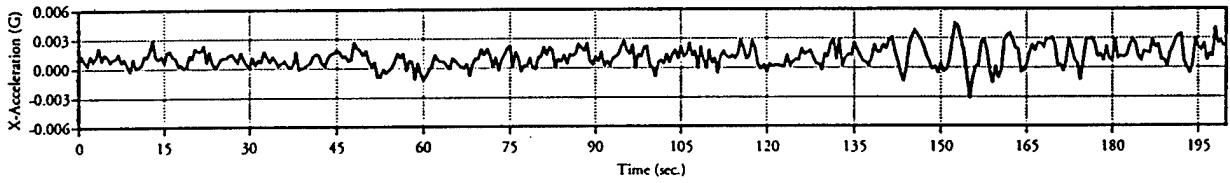
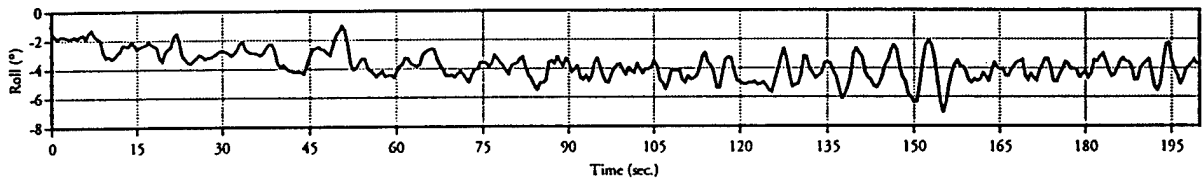
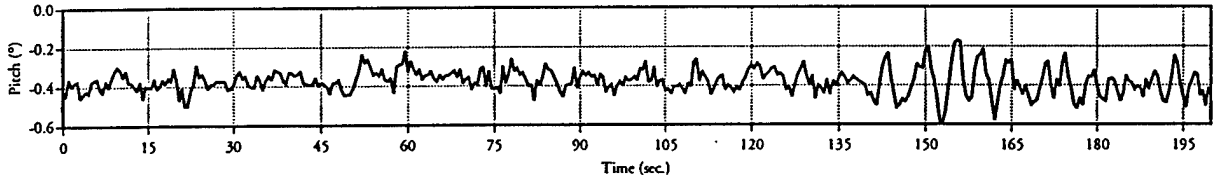
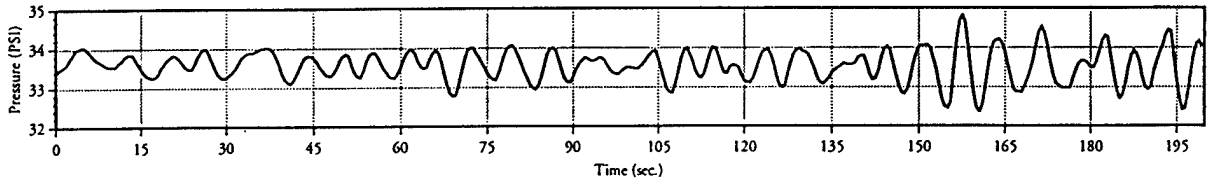
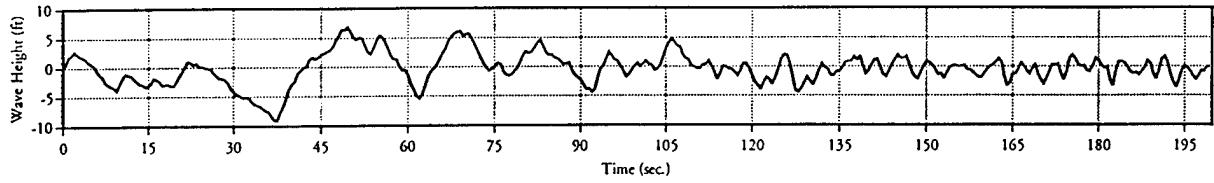



# Rz00a Environmental Data

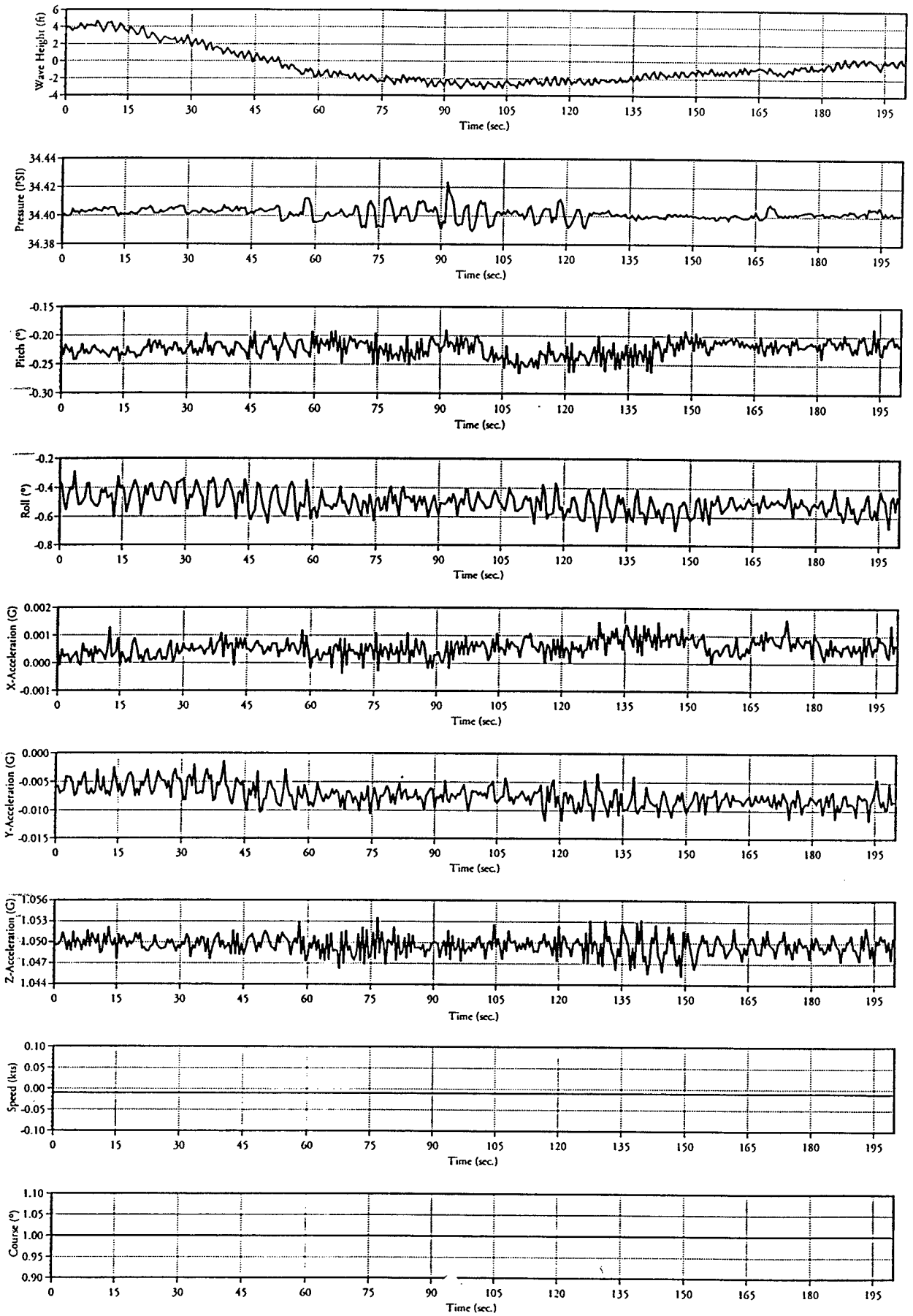

# Rz00b Environmental Data

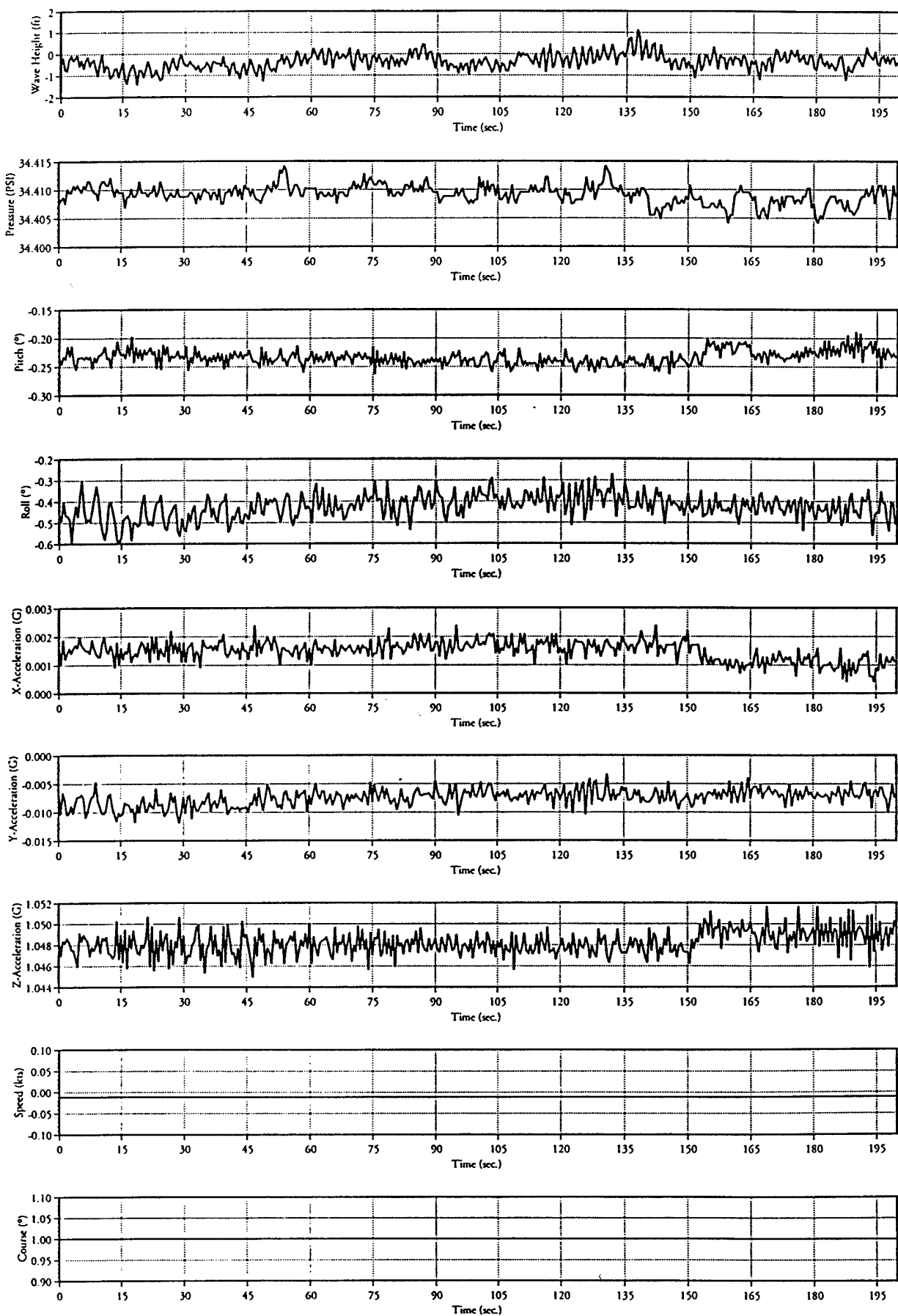

# rZ5a Environmental Data

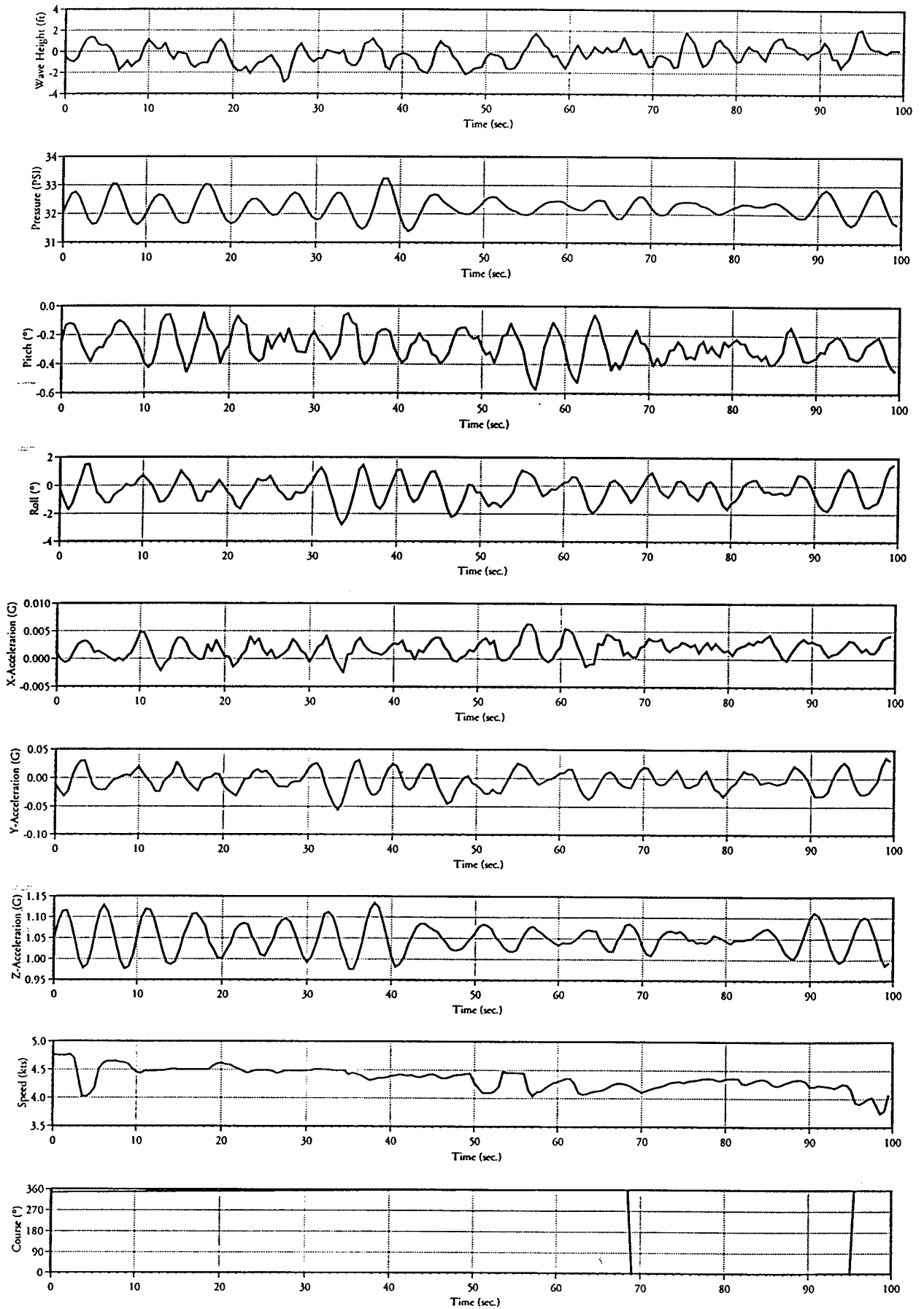

# rZ8a Environmental Data

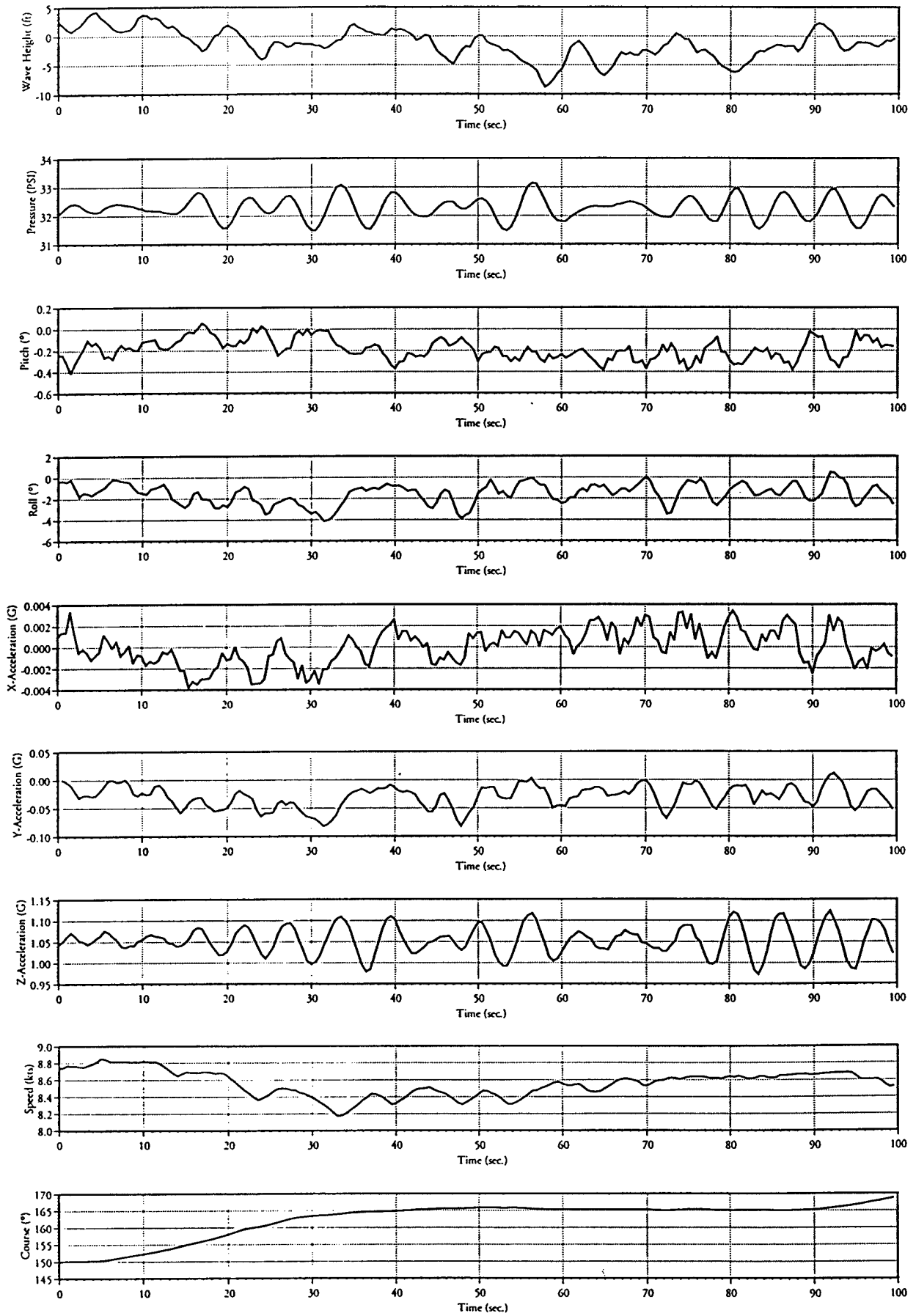

# rZ9a Environmental Data

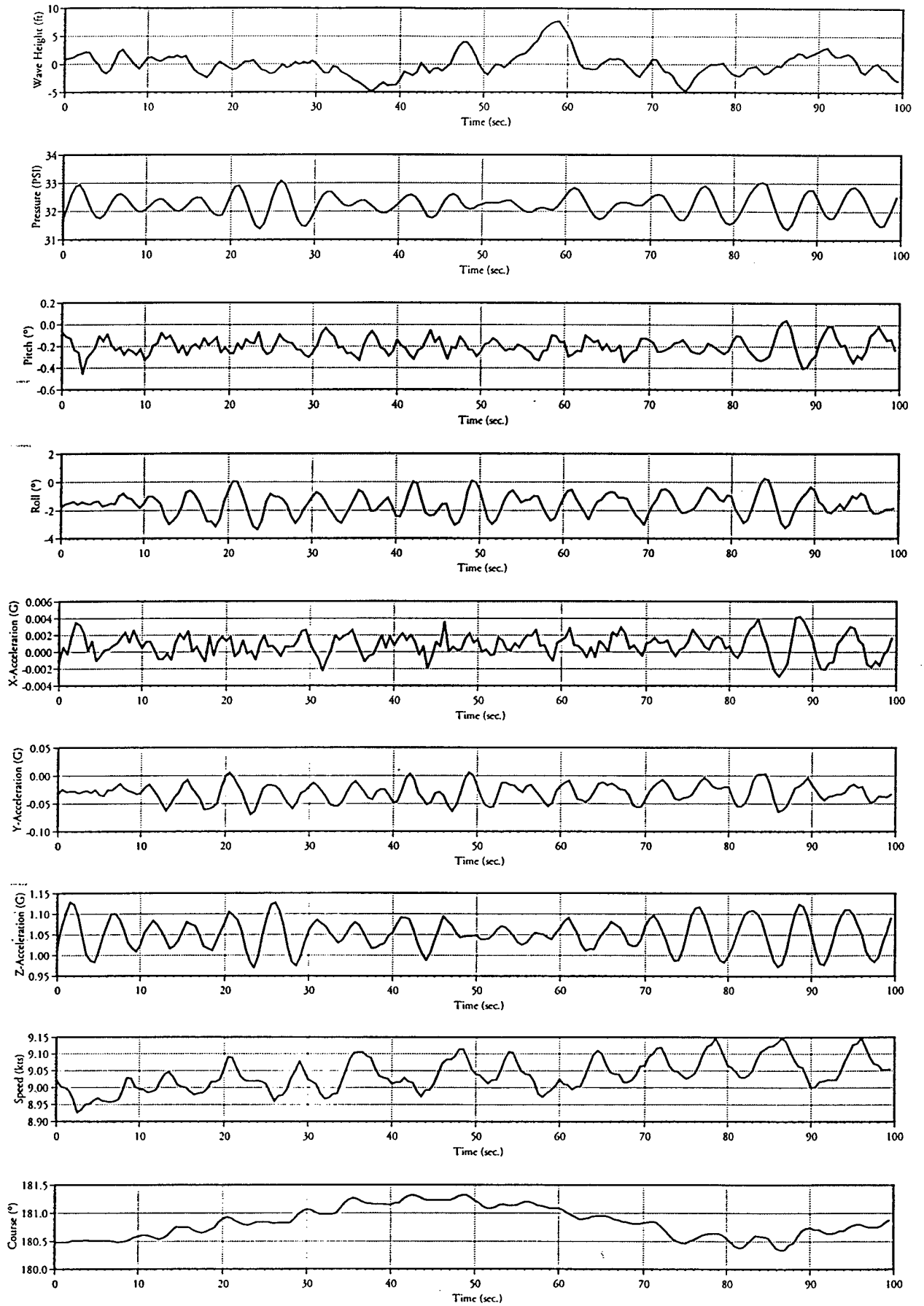

# S10A Environmental Data

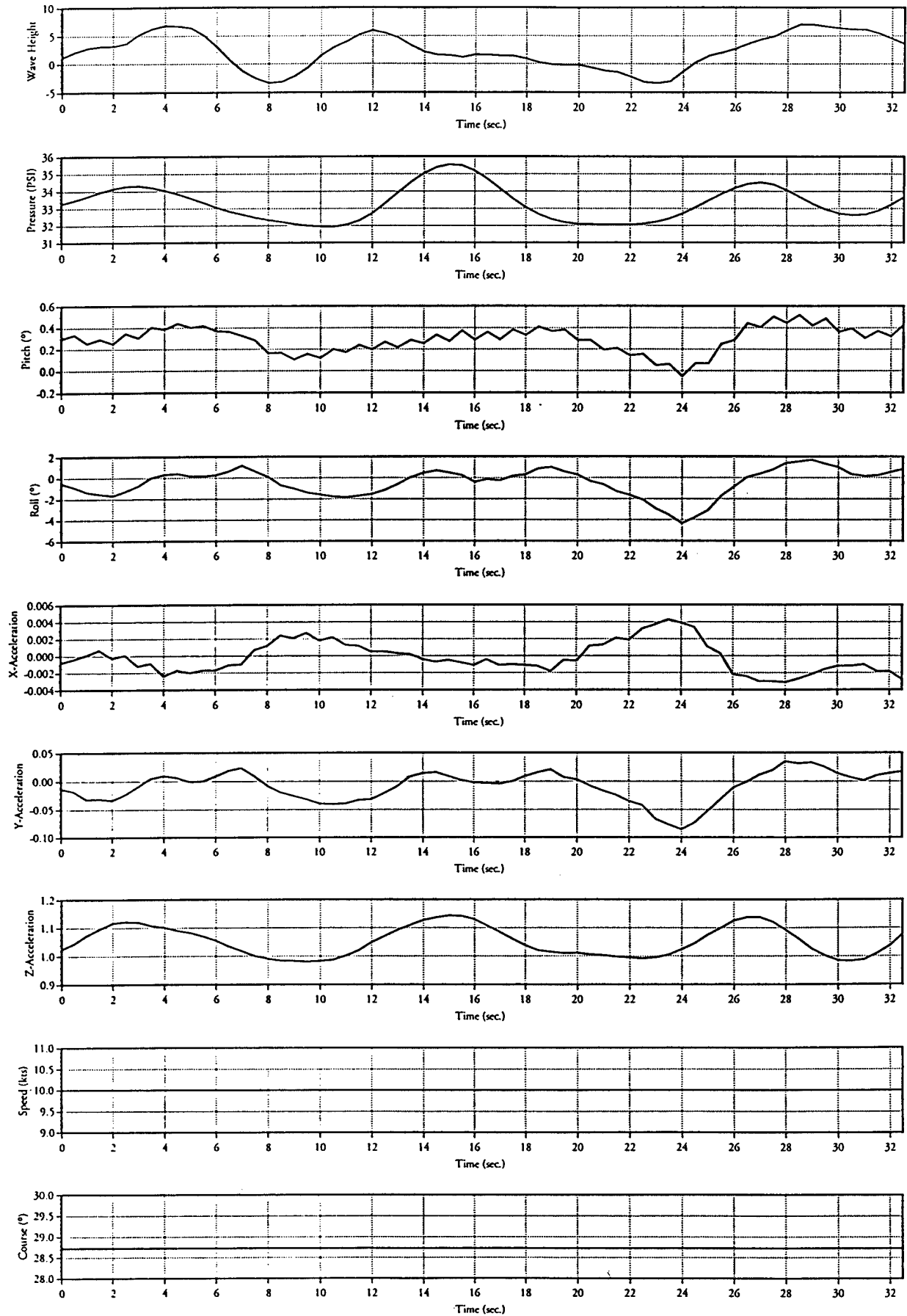

# S17a Environmental Data

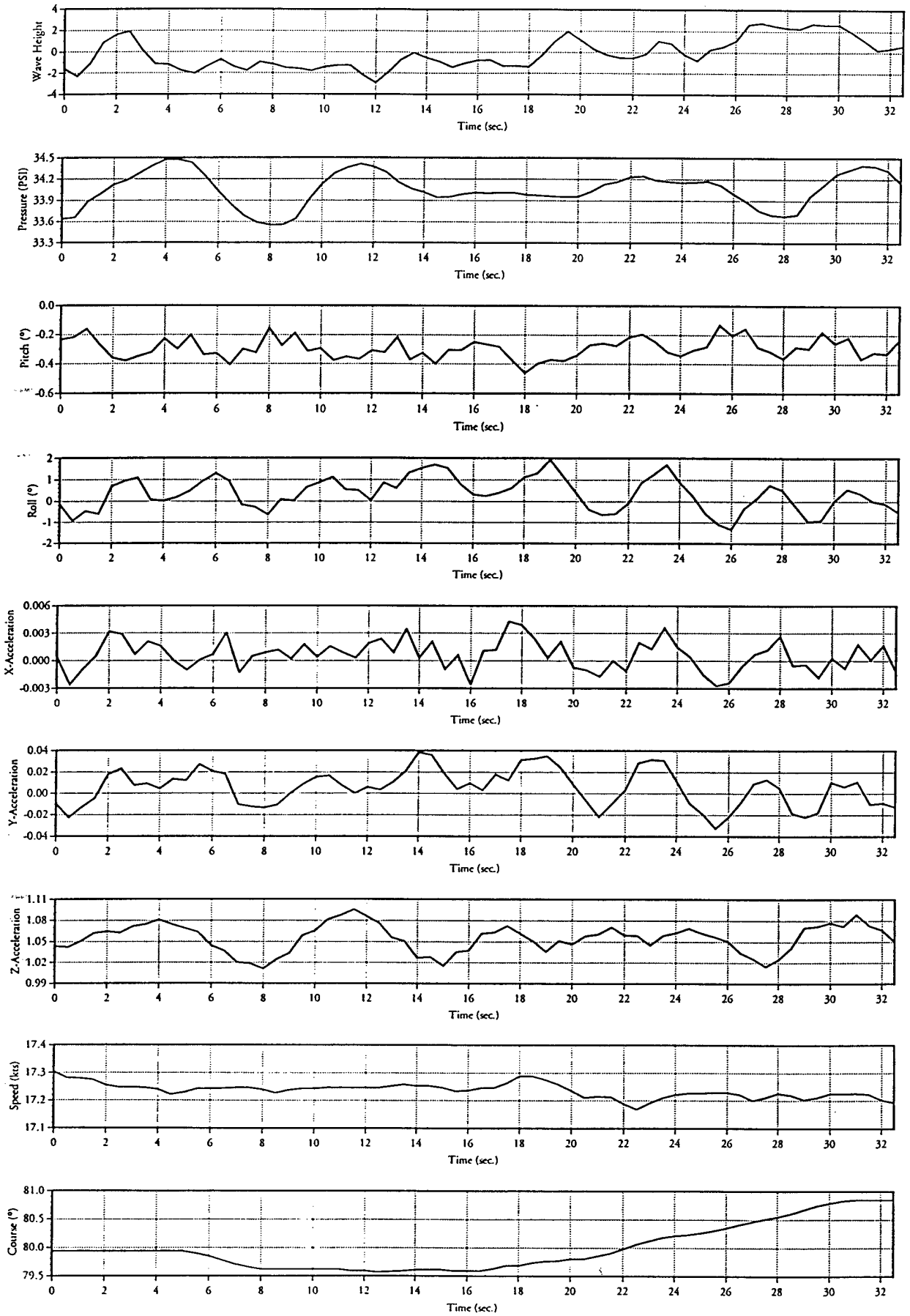

# S27A Environmental Data

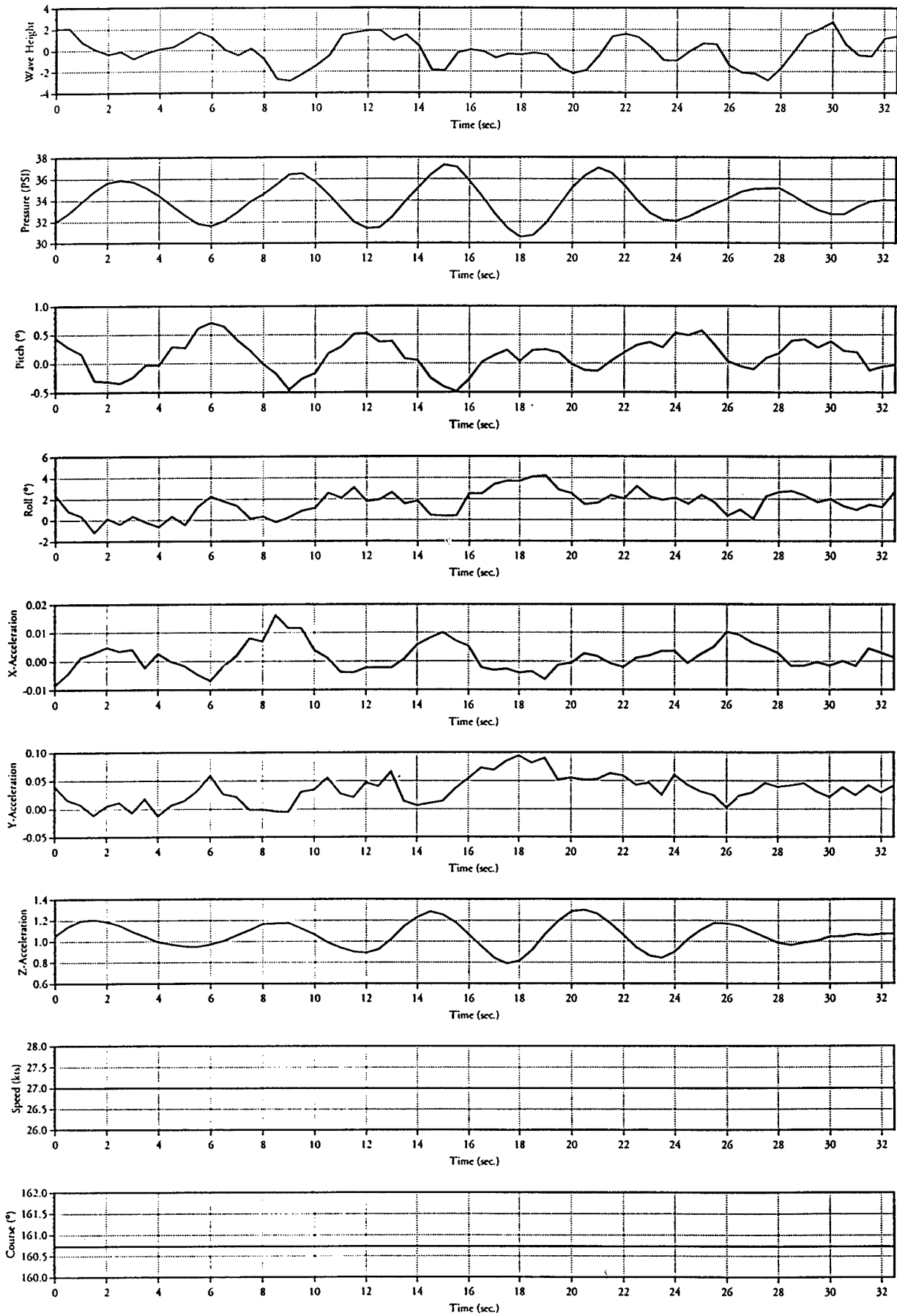



# S29A Environmental Data

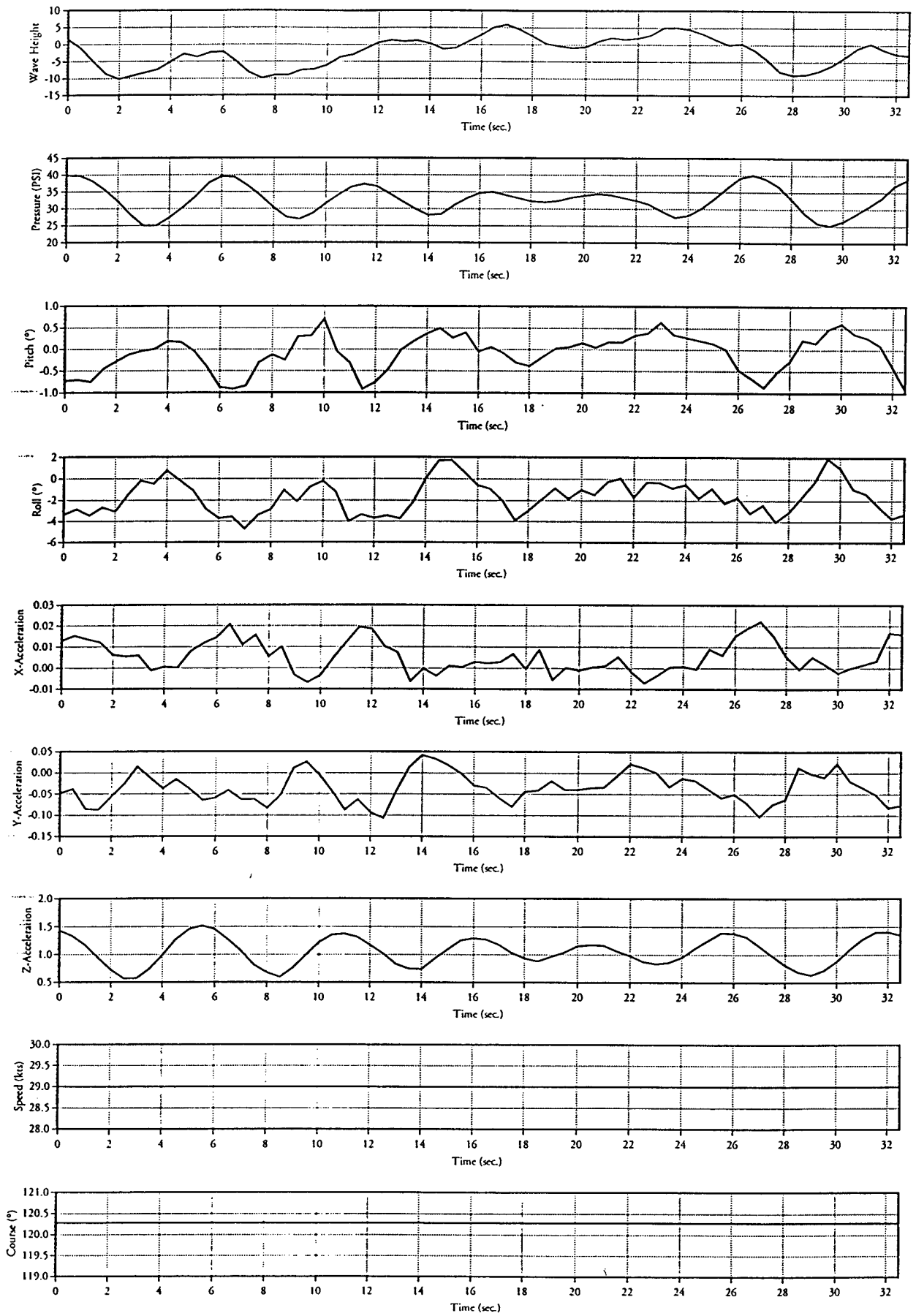

# S4a Environmental Data

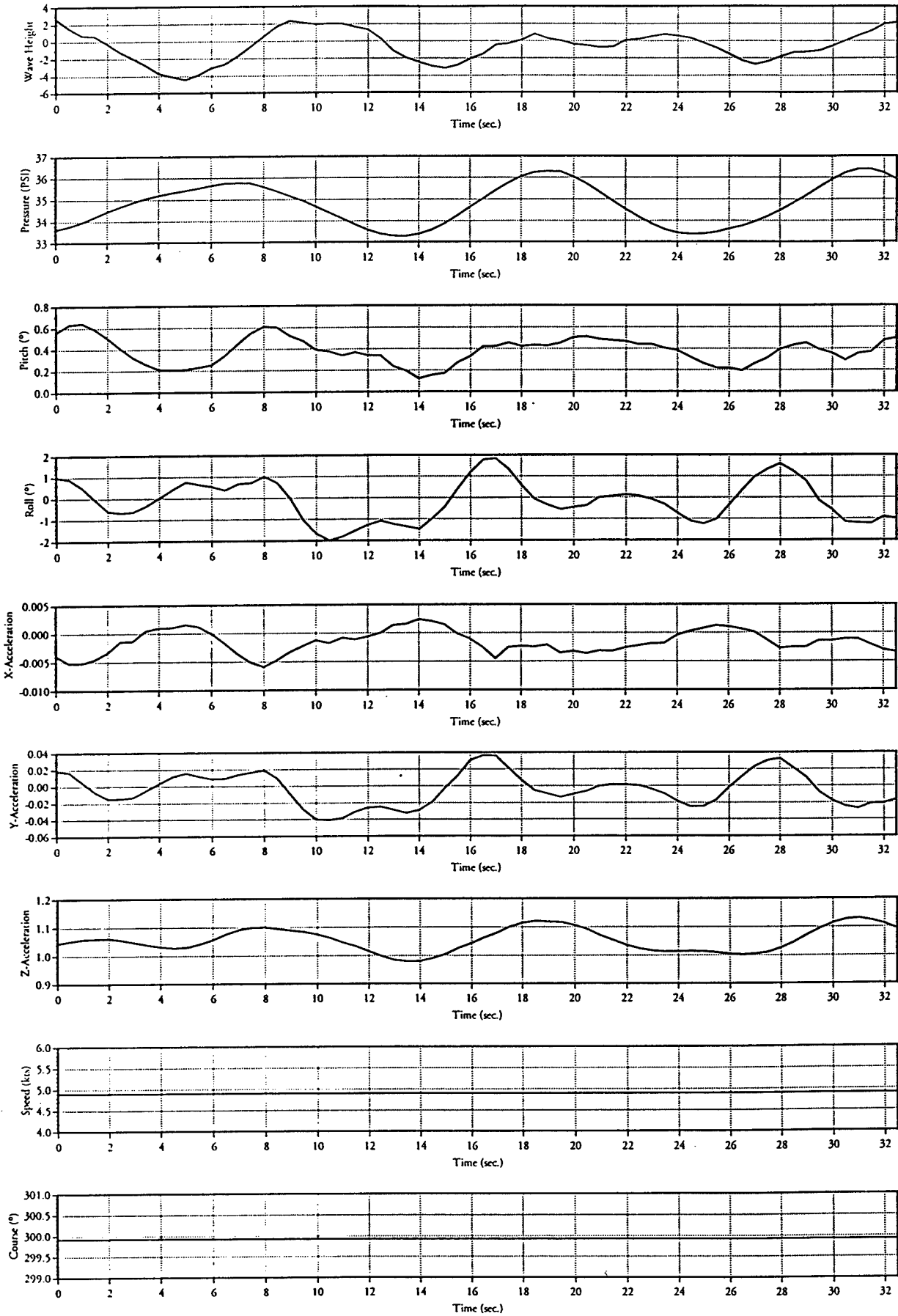

### S6a Environmental Data

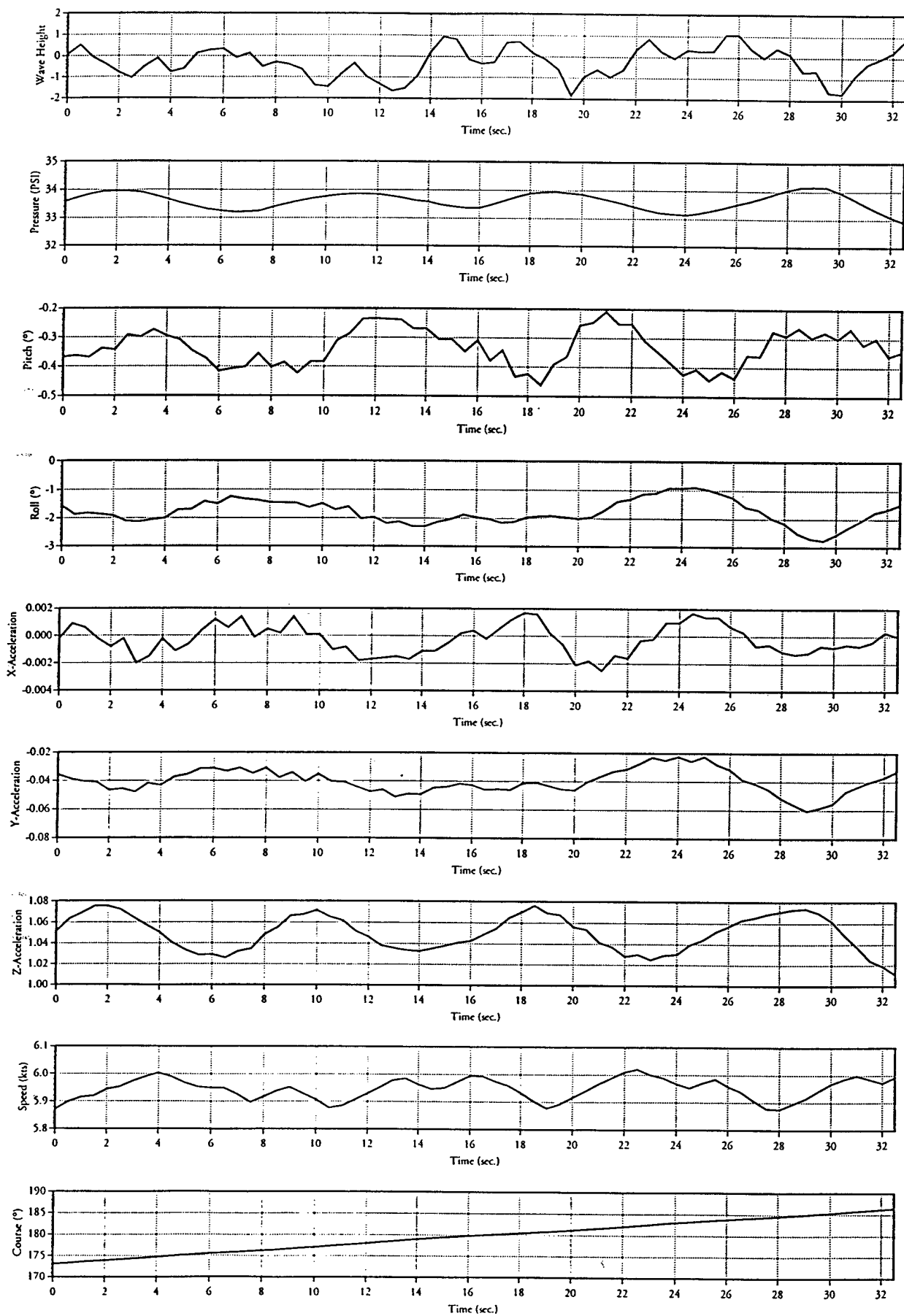

### S7h Environmental Data

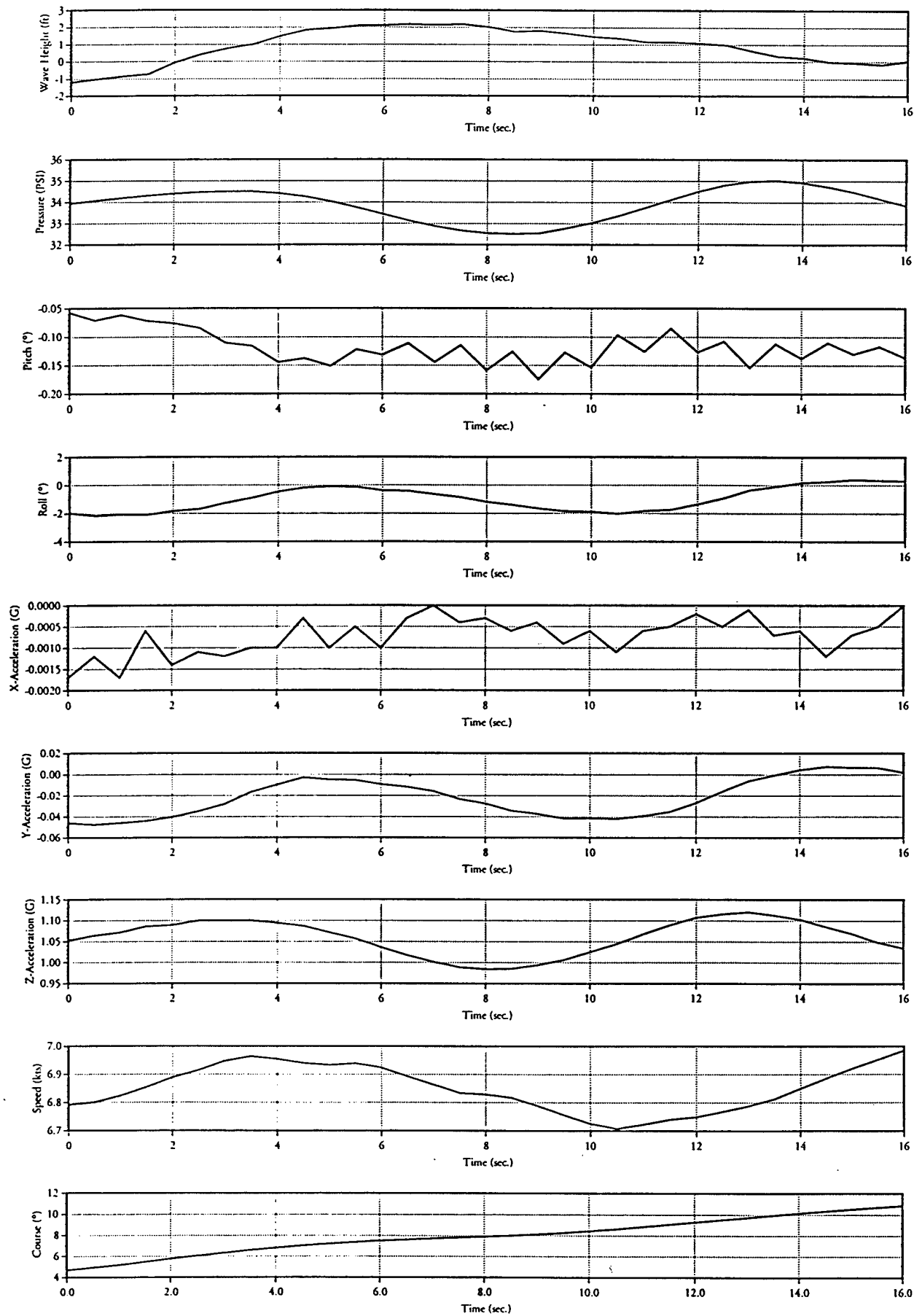

### Sa15a Environmental Data

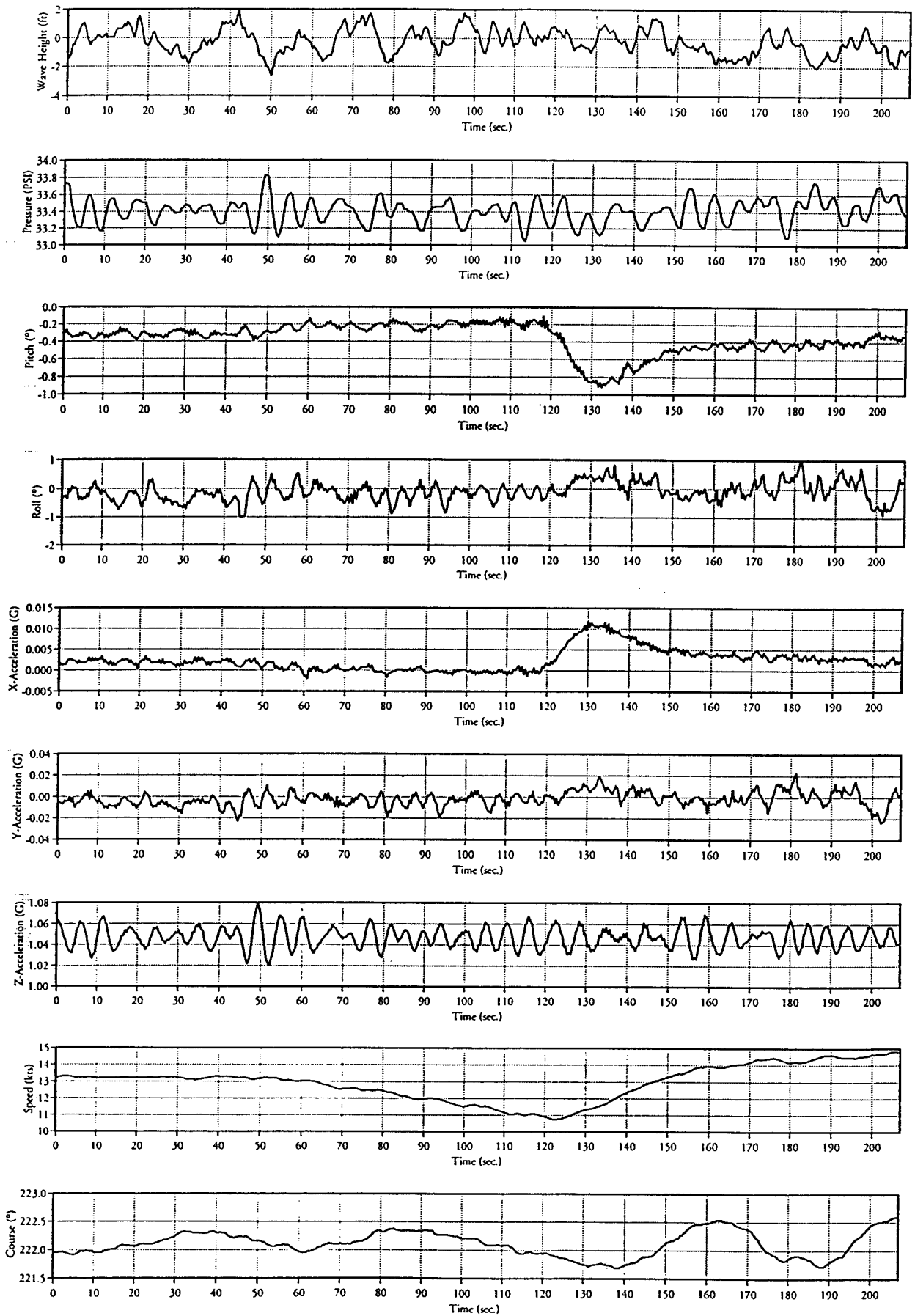

### Sa17a Environmental Data

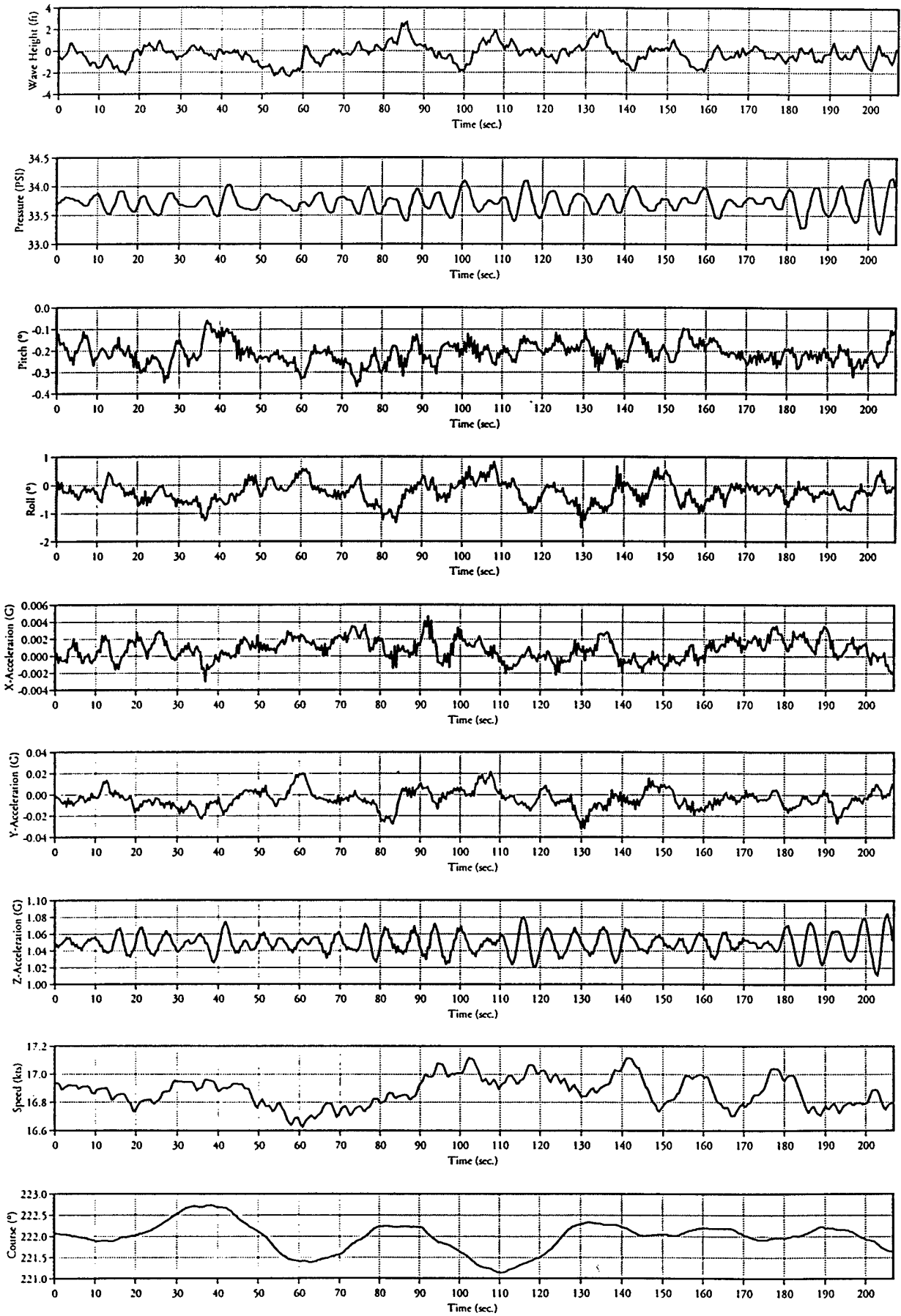

# Sa21a Environmental Data

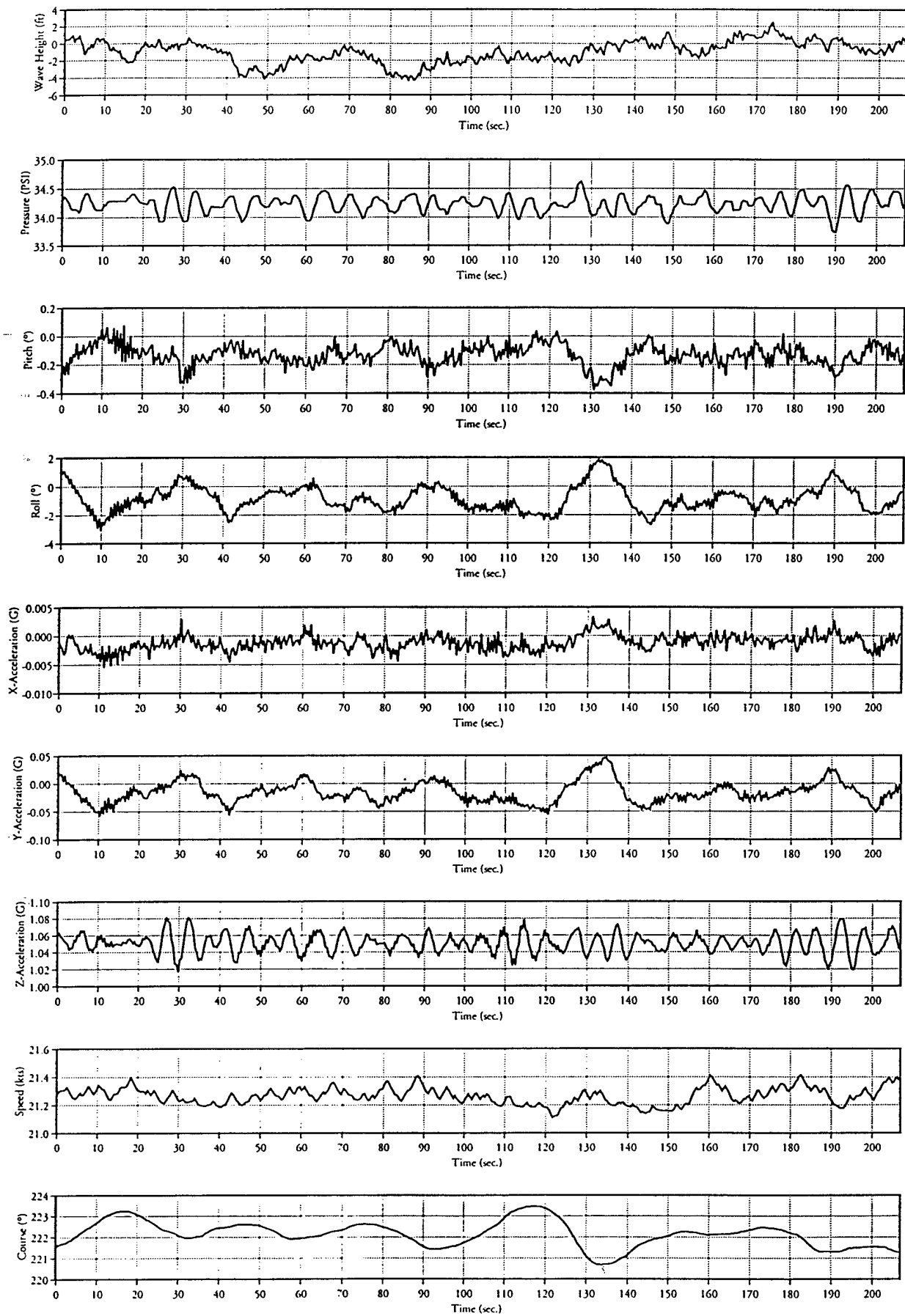

### SIDE30A Environmental Data

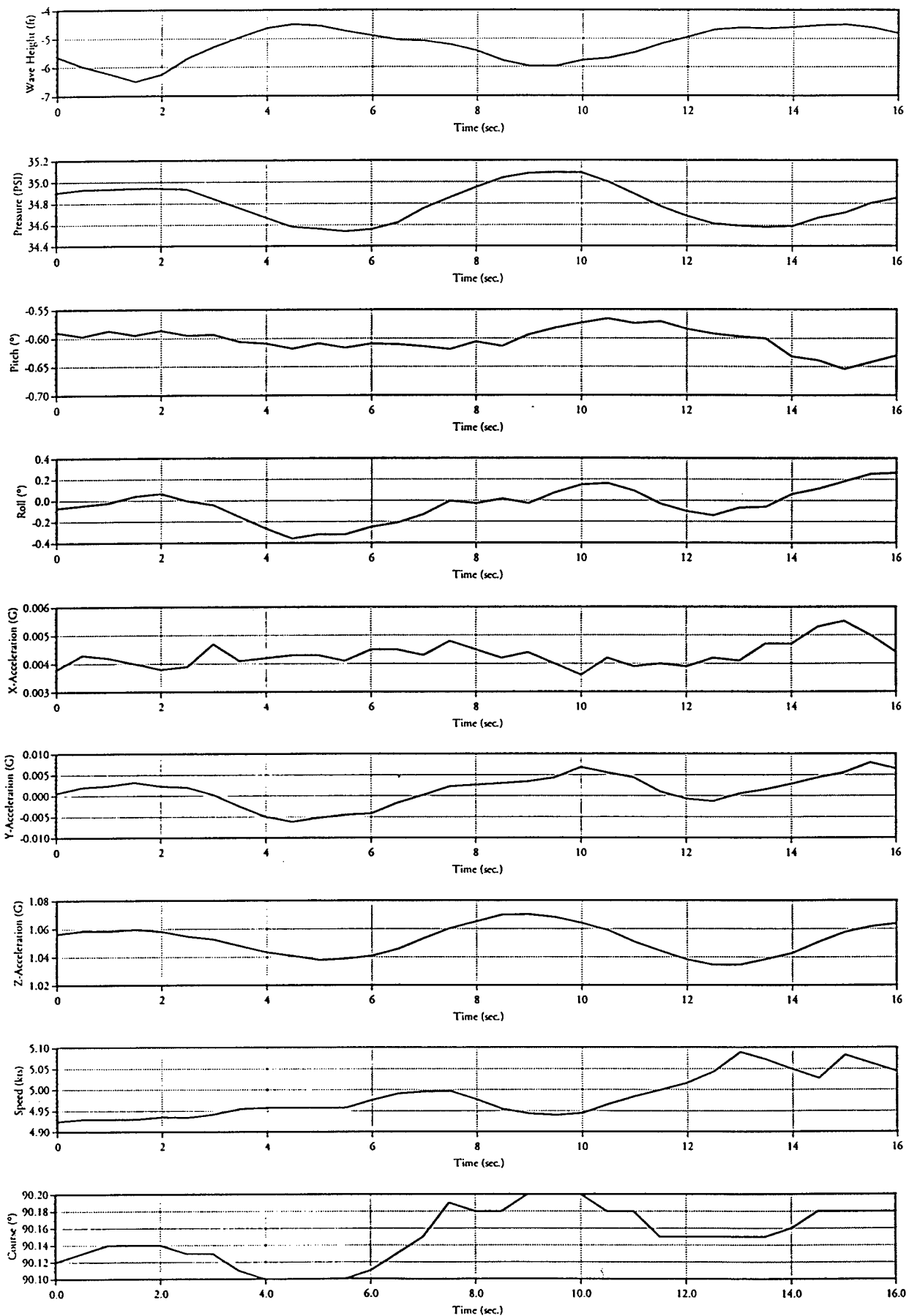



# SIDE30B Environmental Data

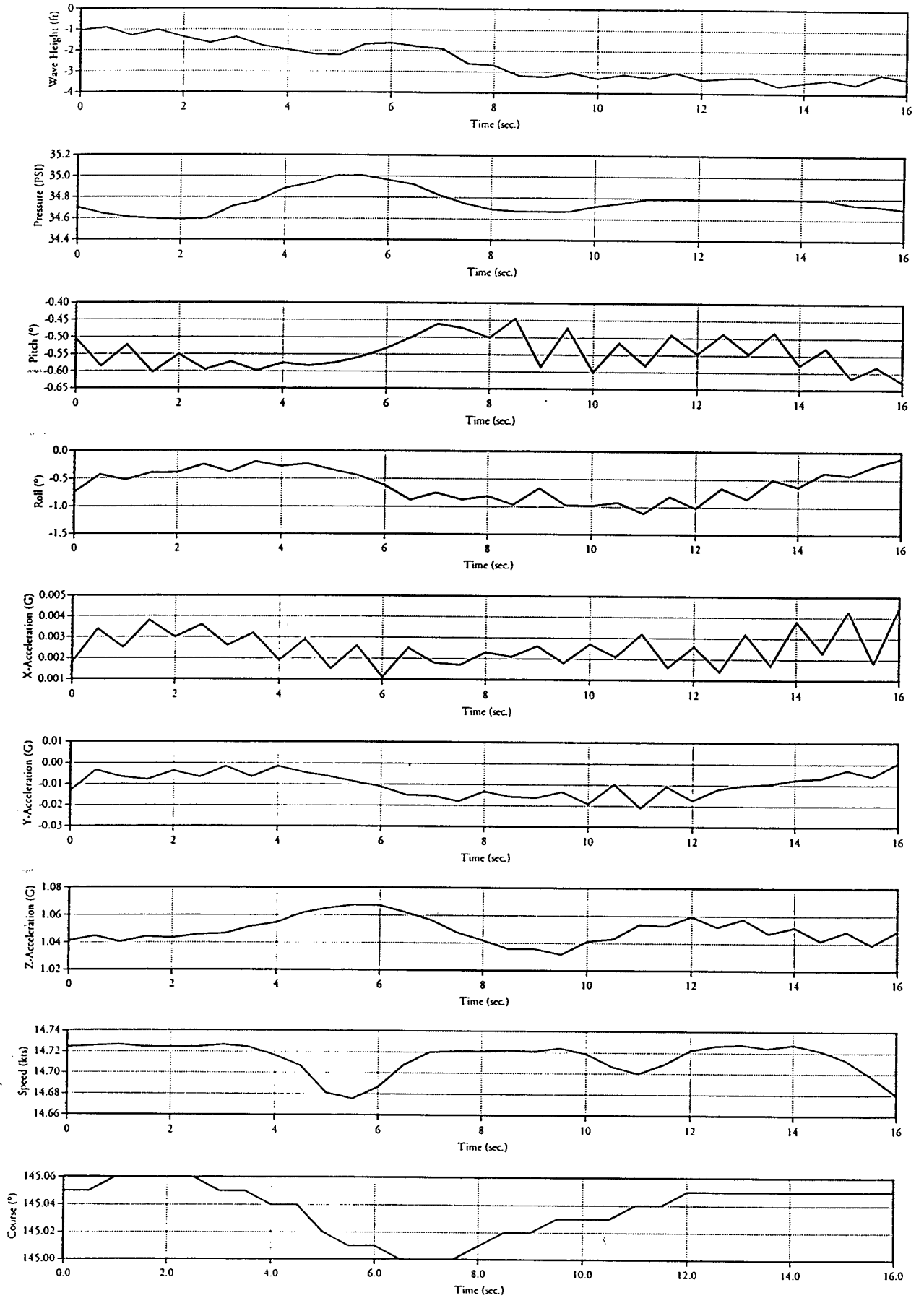

# SIDE31A Environmental Data

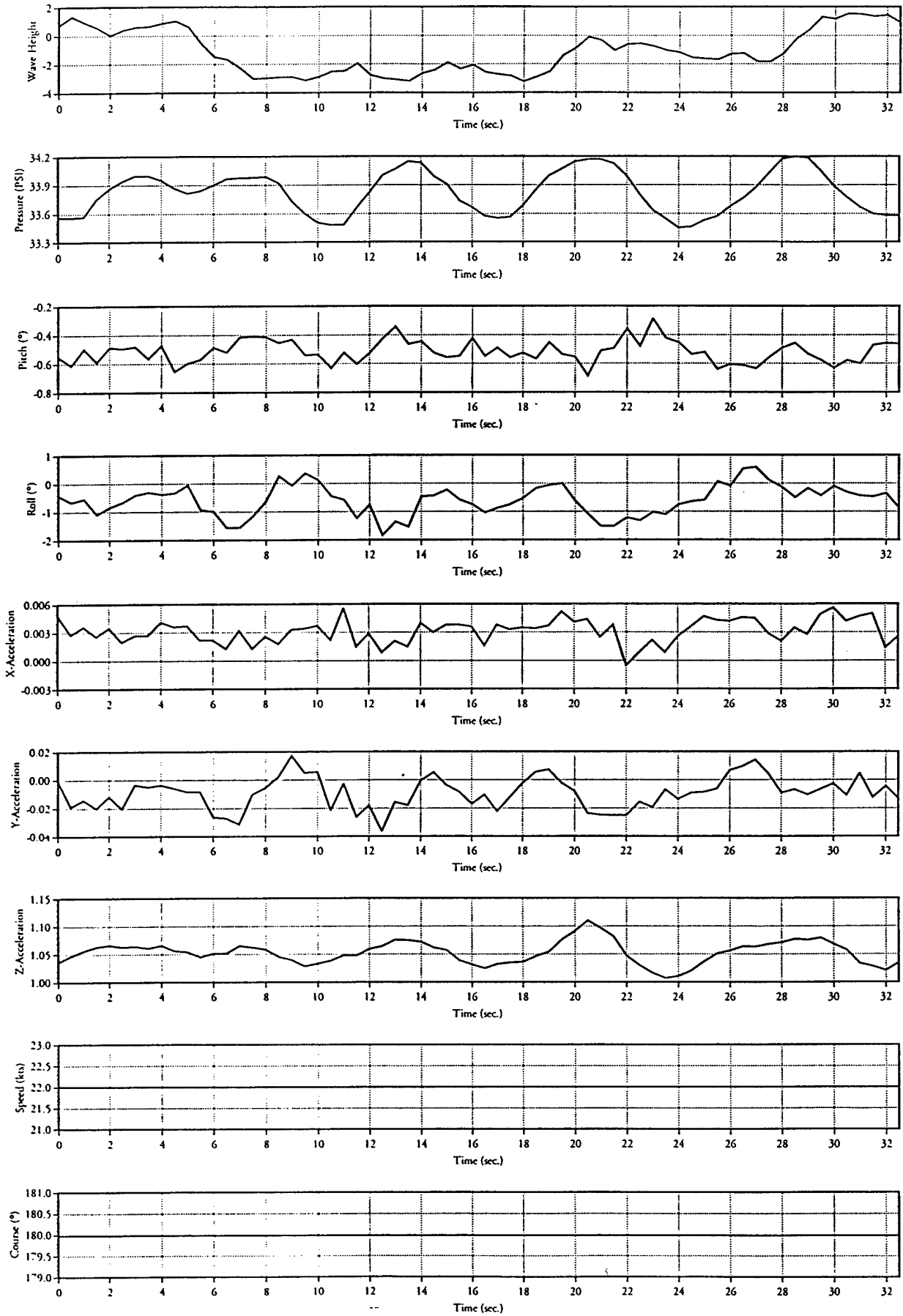

### SM4a Environmental Data

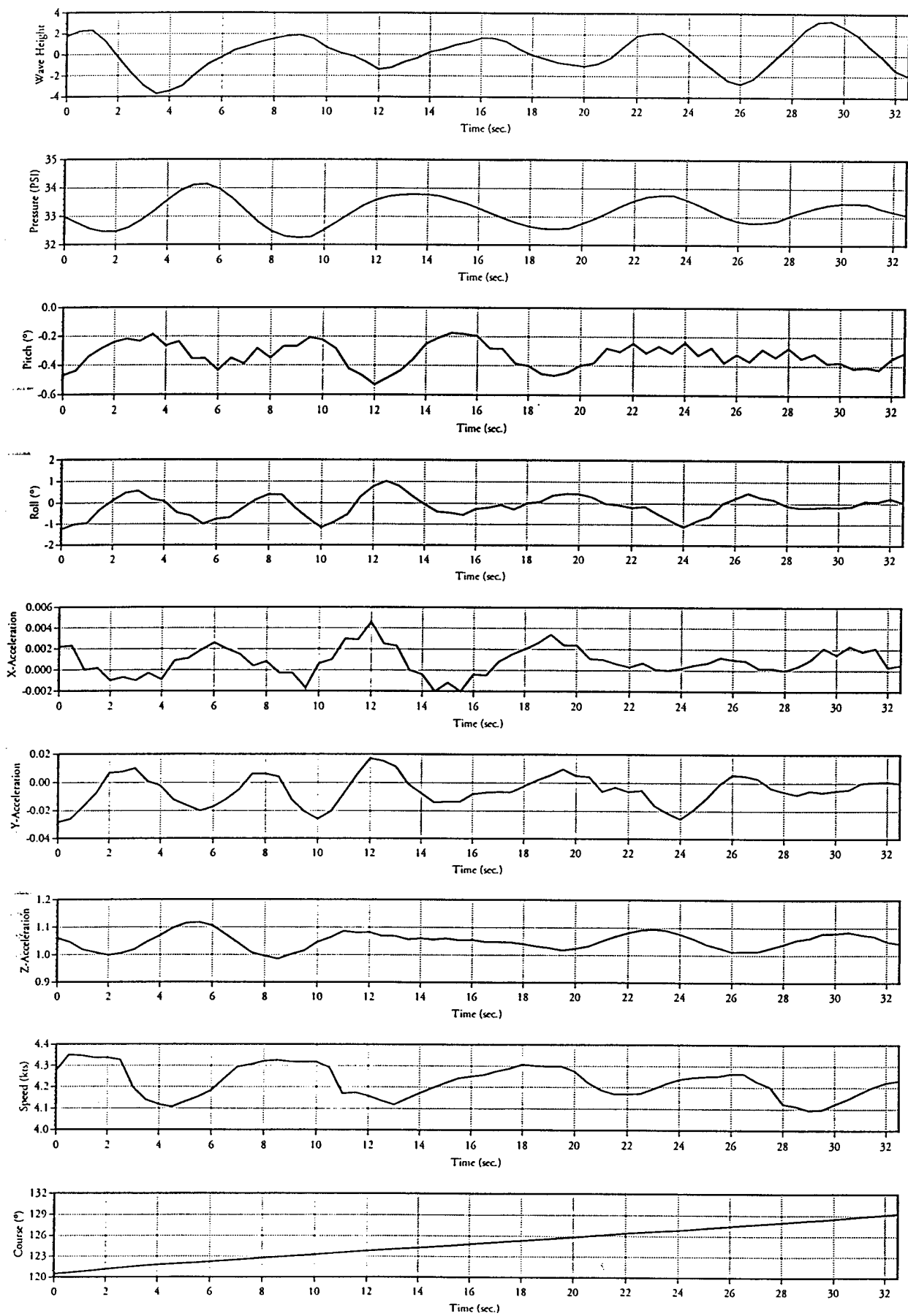

# Sn10a Environmental Data

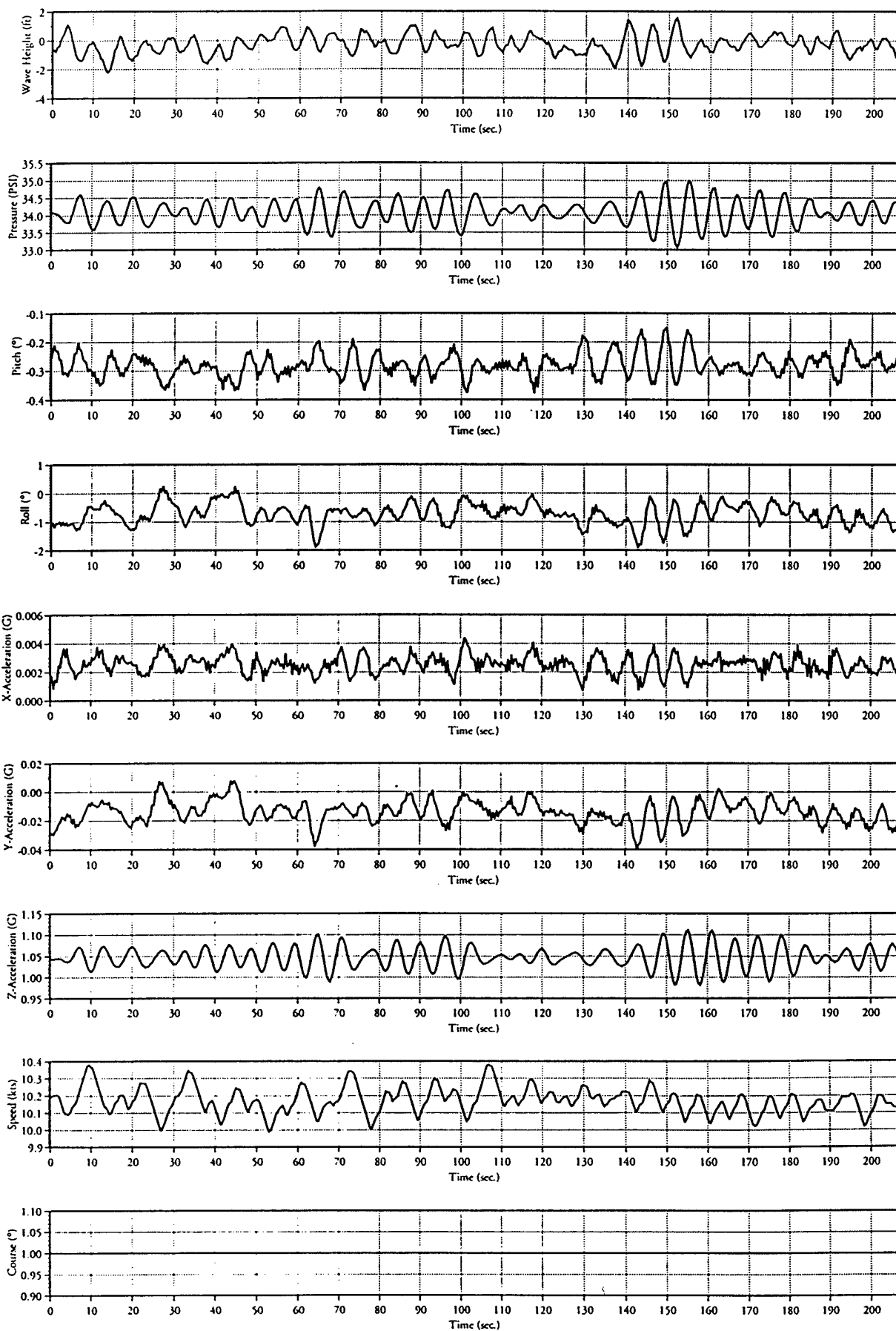

# Sp10a Environmental Data

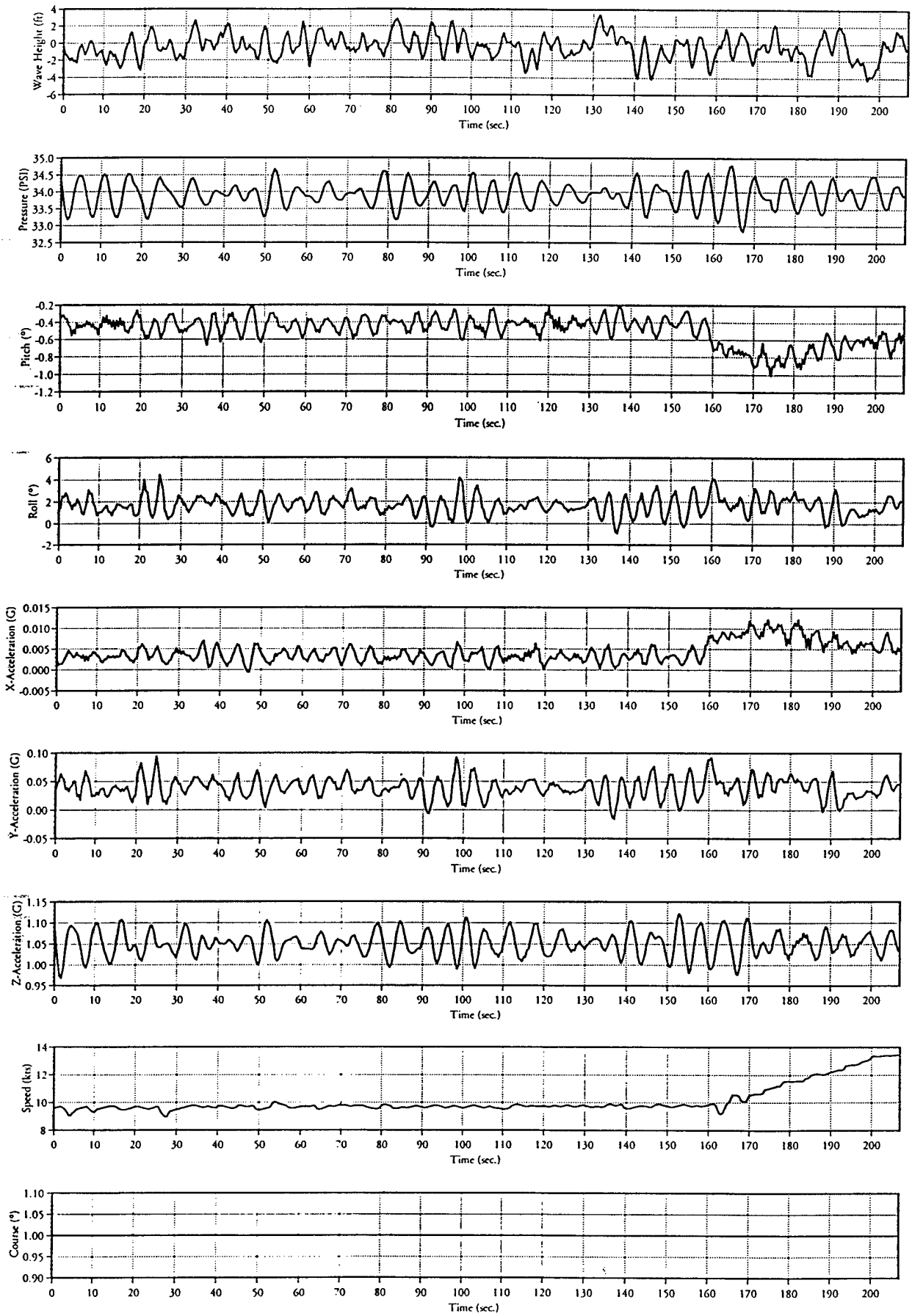

# Sq28a Environmental Data

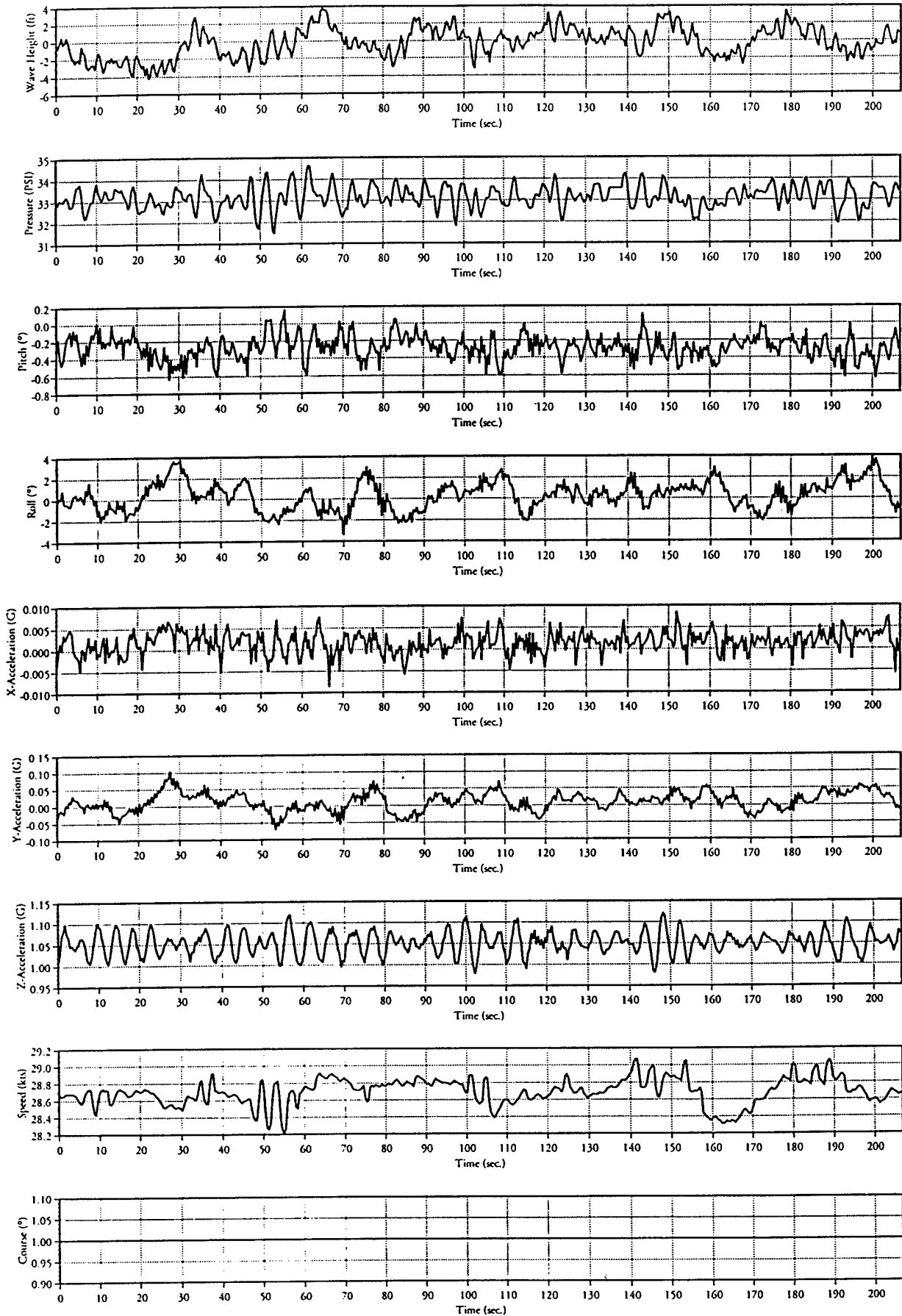

## Appendix 6

Centerline and -4 foot Waterline plots

# Static Deflection Cross Sectional Views

Data Run: Rn00a

Speed: 0.0 Kts

Sea State: 2

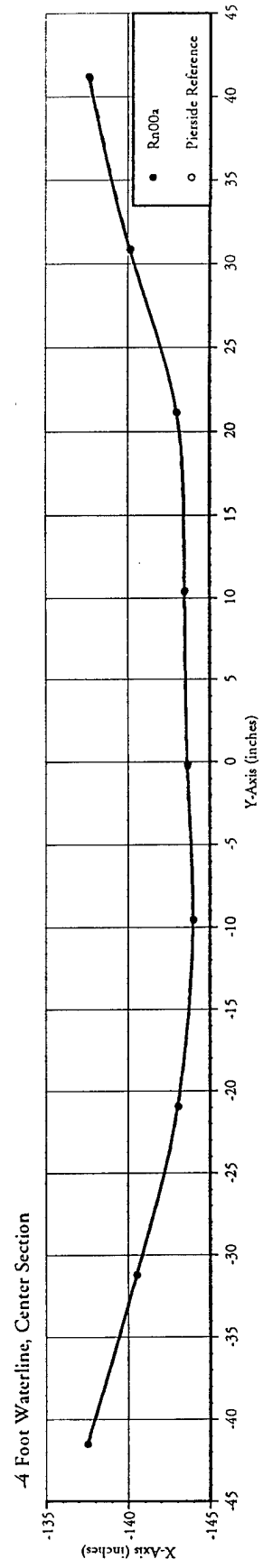
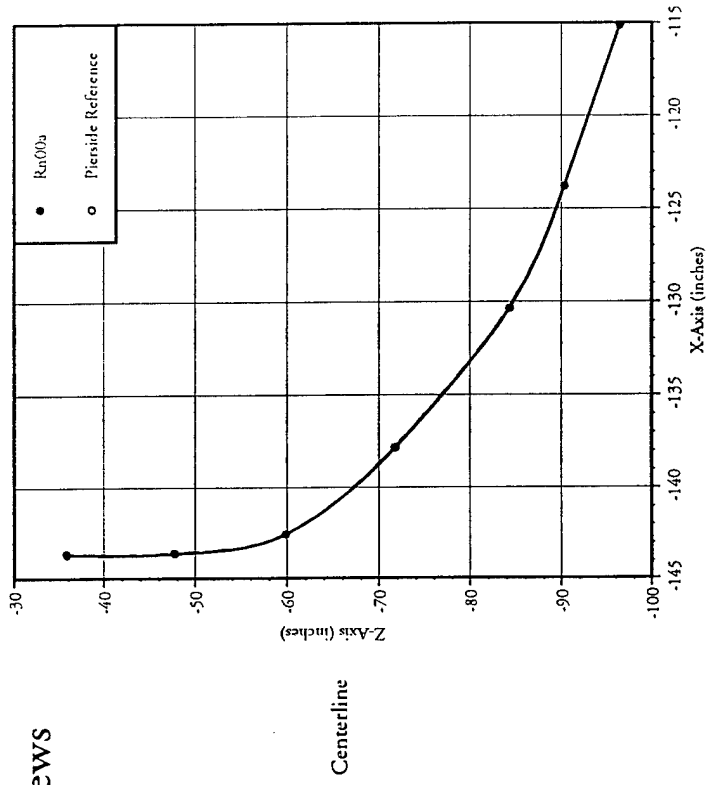



# Static Deflection Cross Sectional Views

## Data Run: Rp07a

Speed: 1.47 Kts  
Sea State: 3

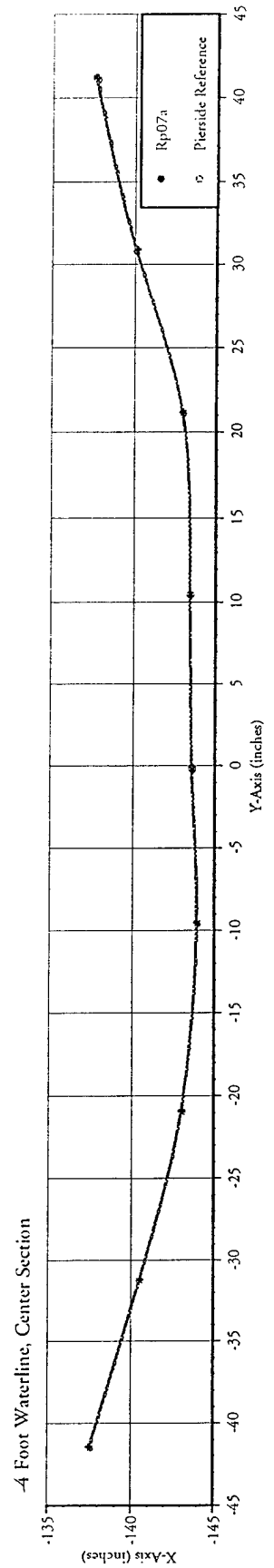
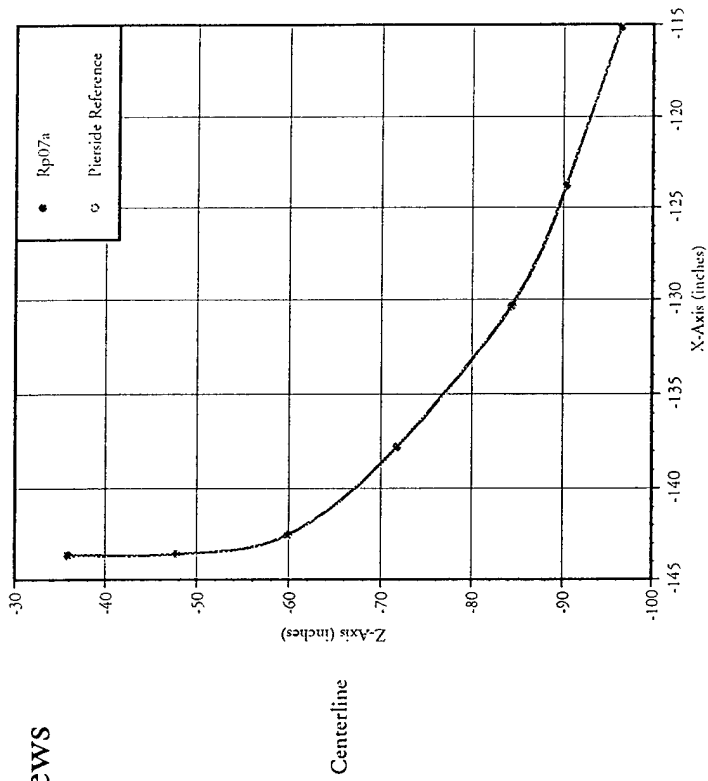

# Static Deflection Cross Sectional Views

## Data Run: RL03a

Speed: 2.6 Kts

Sea State: 2

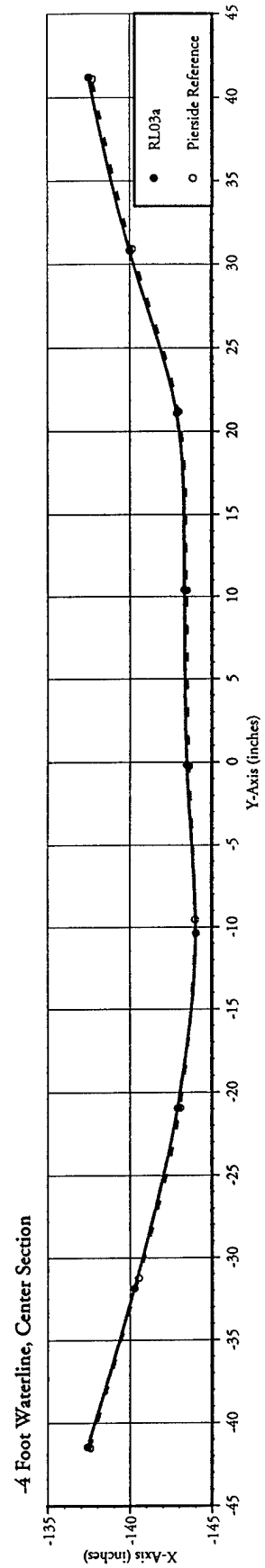
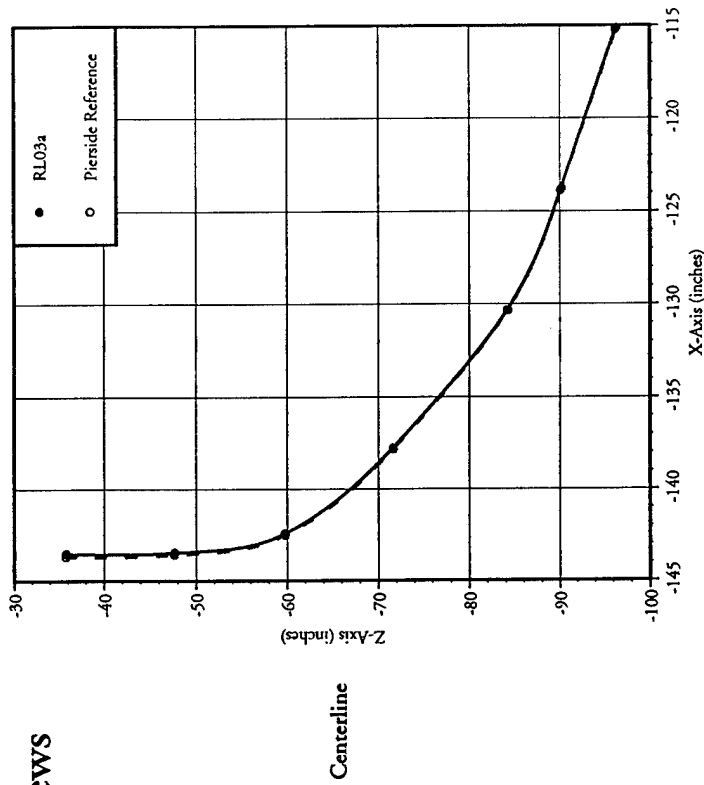

# Static Deflection Cross Sectional Views

## Data Run: Rp04a

Speed: 3.7 Kts  
Sea State: 2

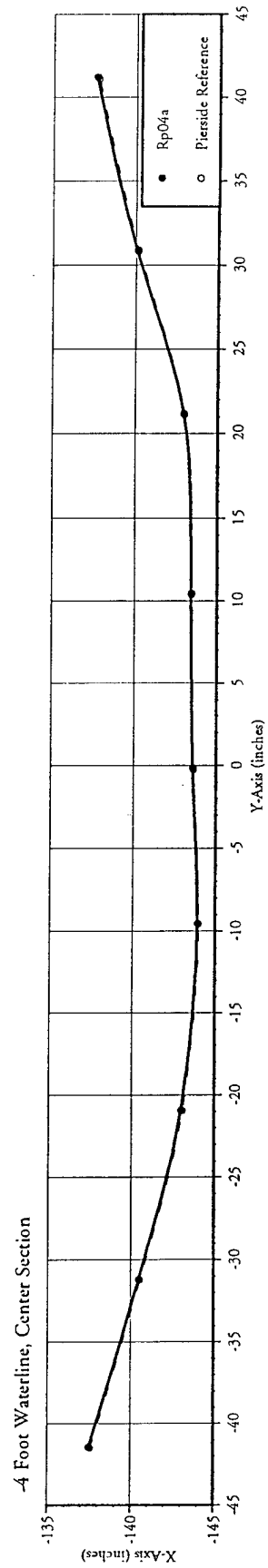
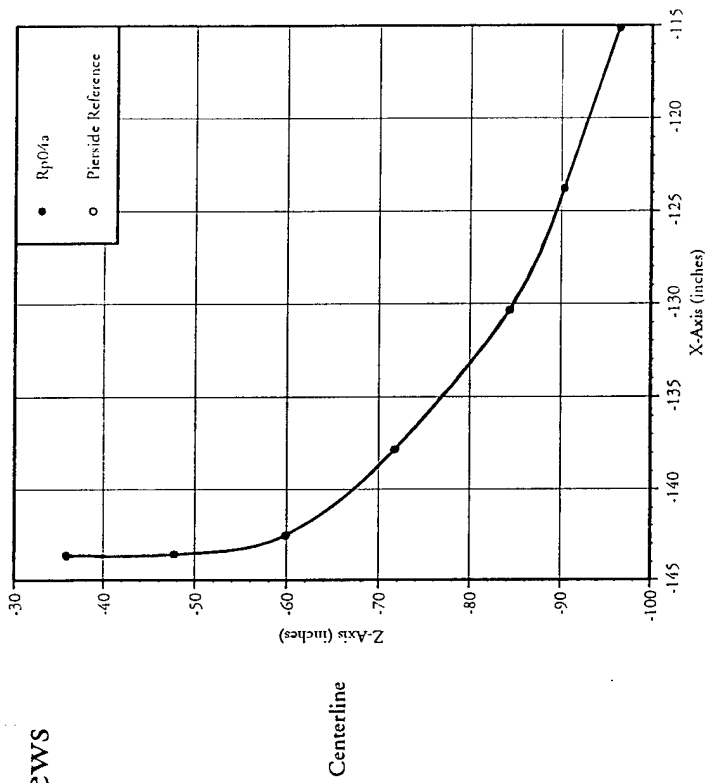

# Static Deflection Cross Sectional Views

Data Run: Rt05a

Speed: 4.1 Kts

Sea State: 3

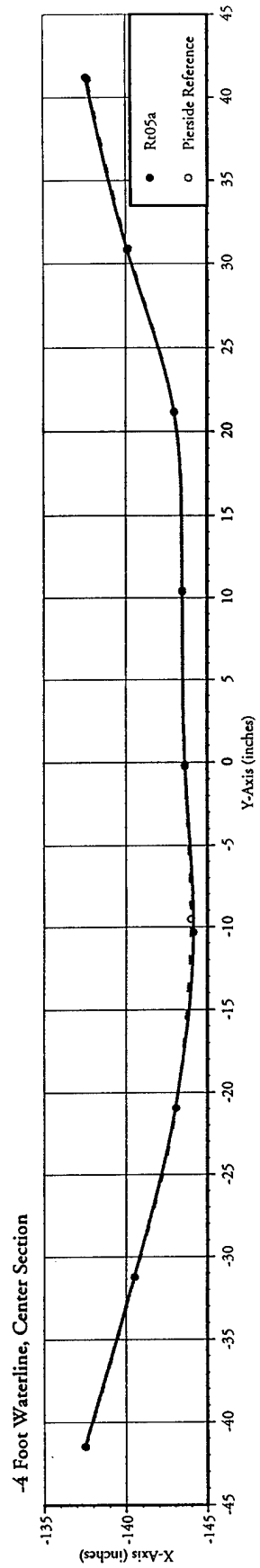
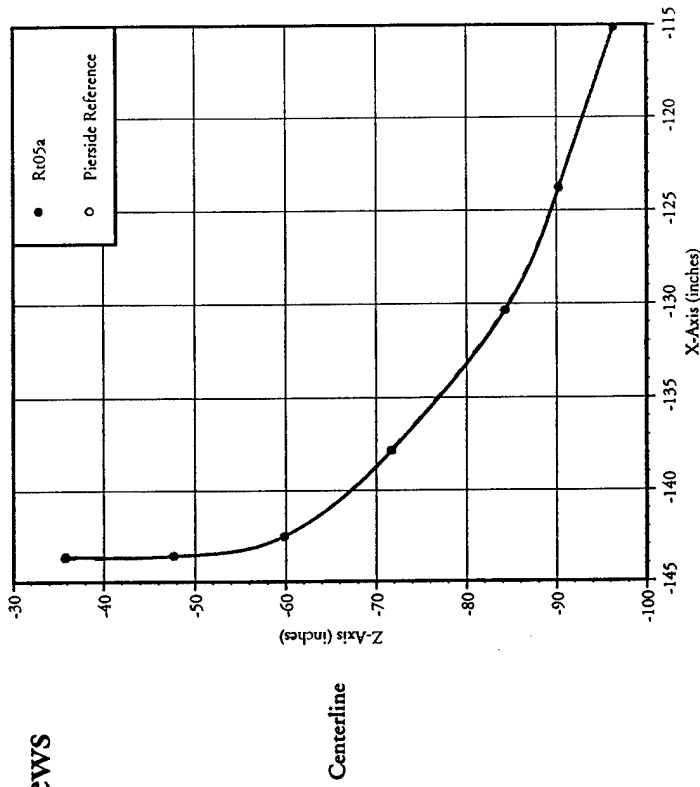

# Static Deflection Cross Sectional Views

## Data Run: Rn04a

Speed: 4.3 Kts  
Sea State: 2

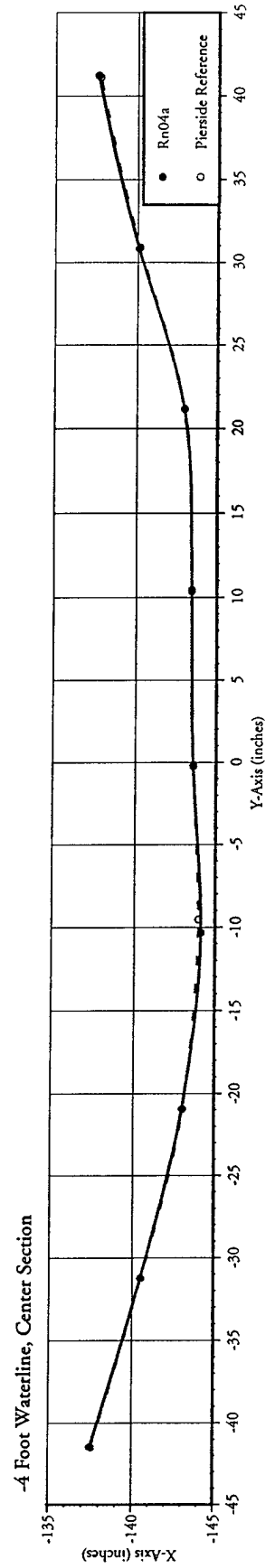
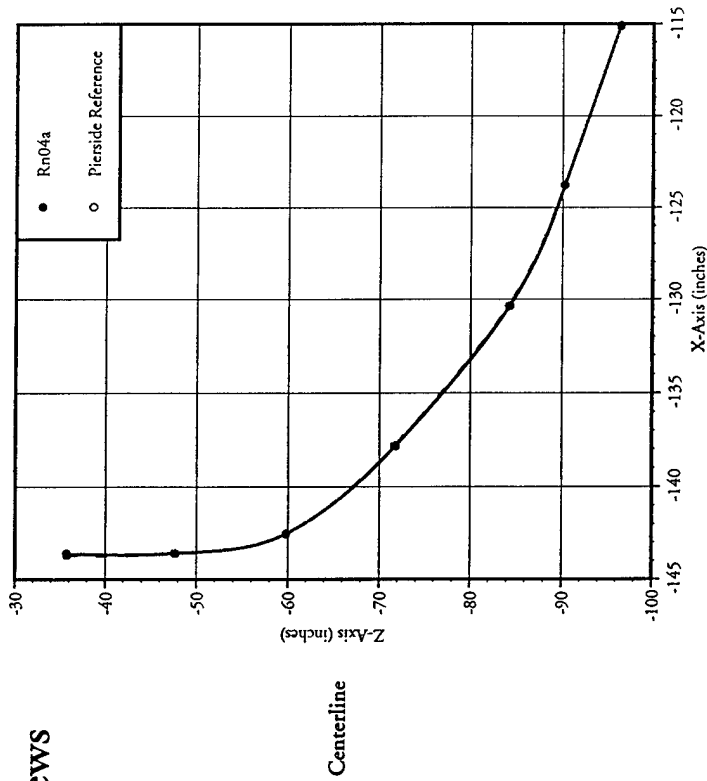

# Static Deflection Cross Sectional Views

Data Run: CAL5a

Speed: 4.8 Kts

Sea State: 3

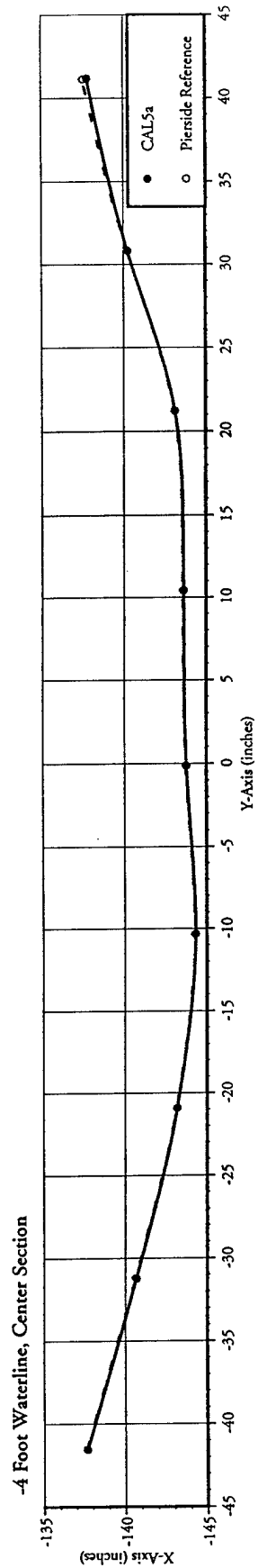
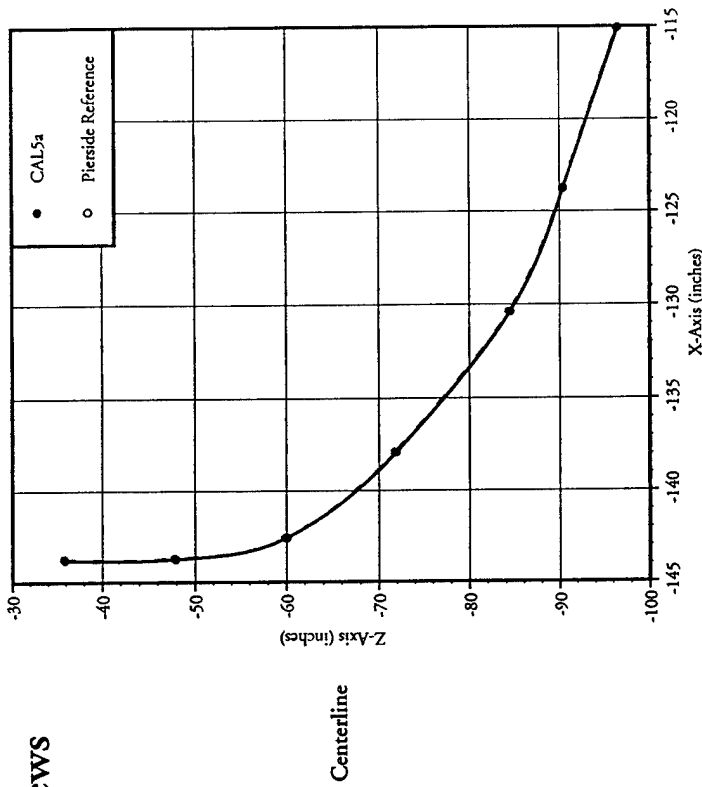

# Static Deflection Cross Sectional Views

## Data Run: Rp05a

Speed: 5.23 Kts  
Sea State: 2

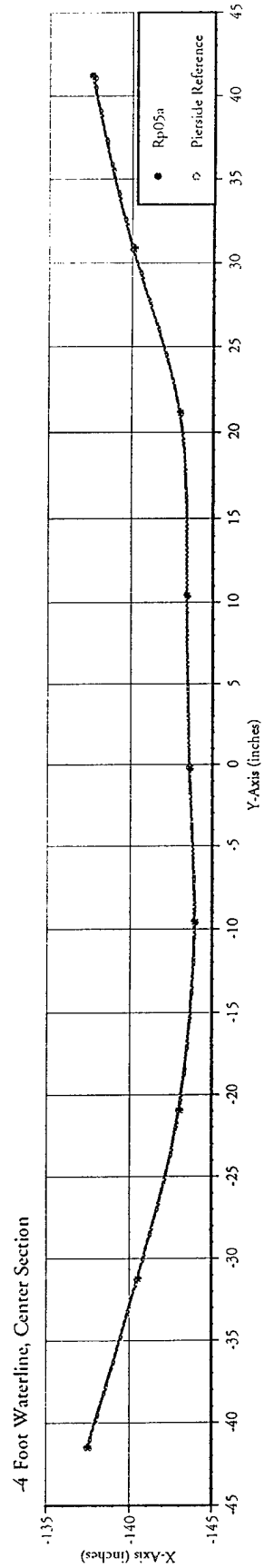
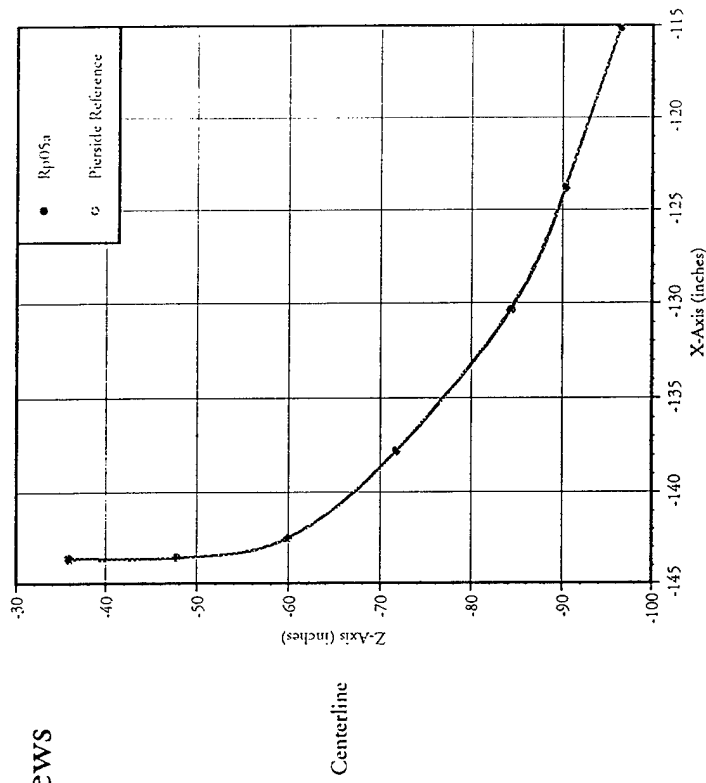

# Static Deflection Cross Sectional Views

## Data Run: Rp04b

Speed: 5.3 Kts  
Sea State = 2

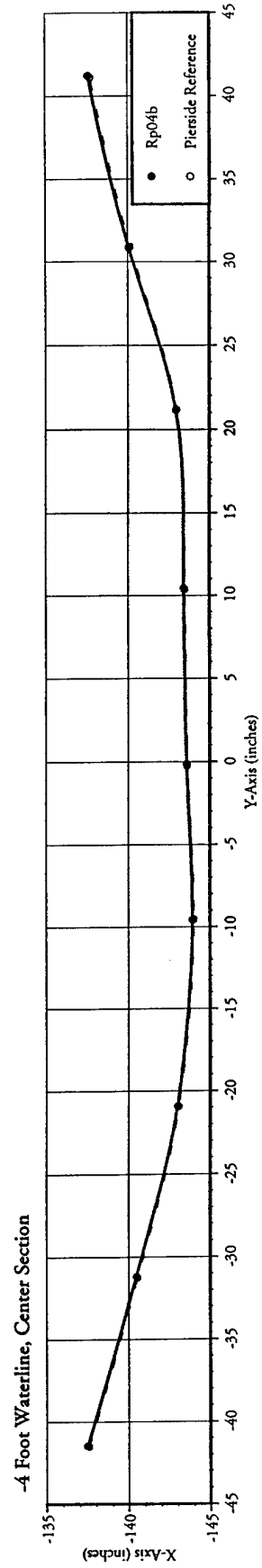
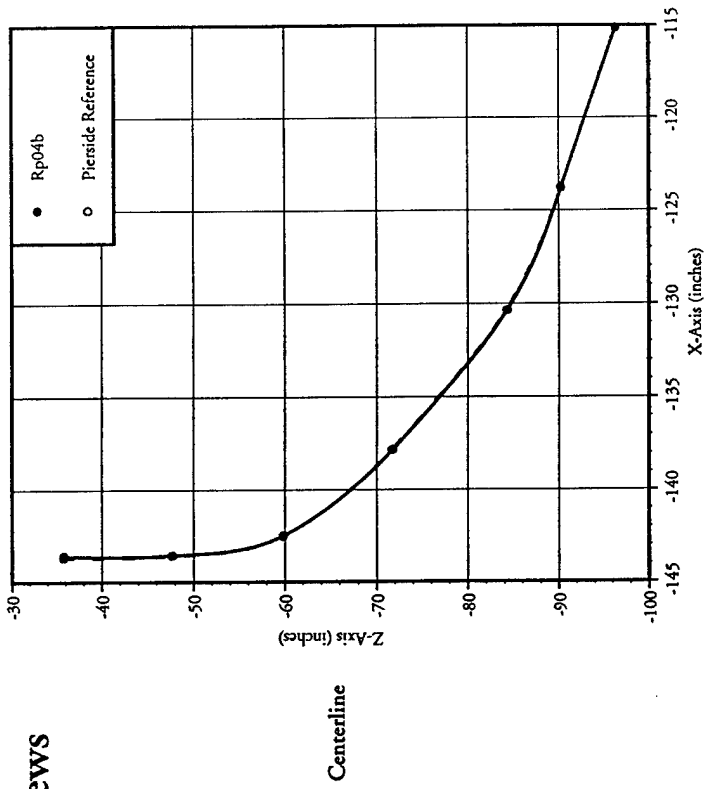



# Static Deflection Cross Sectional Views

## Data Run: Rq05a

Speed: 5.4 Kts  
Sea State: 3

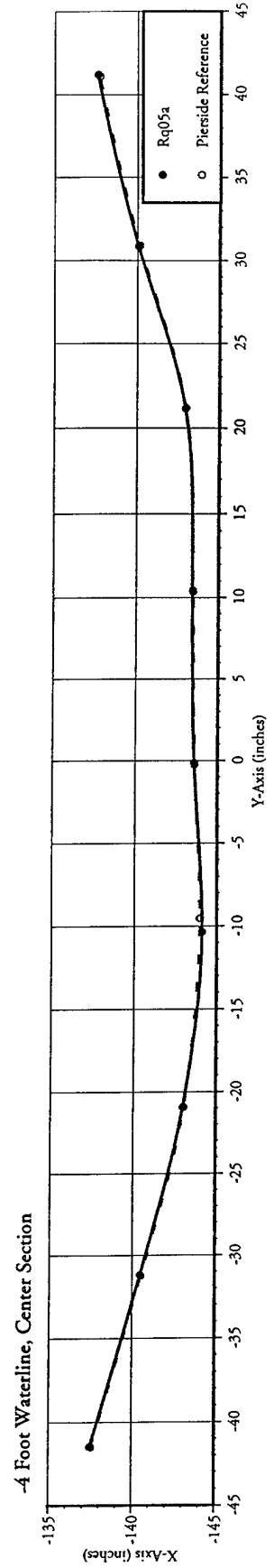
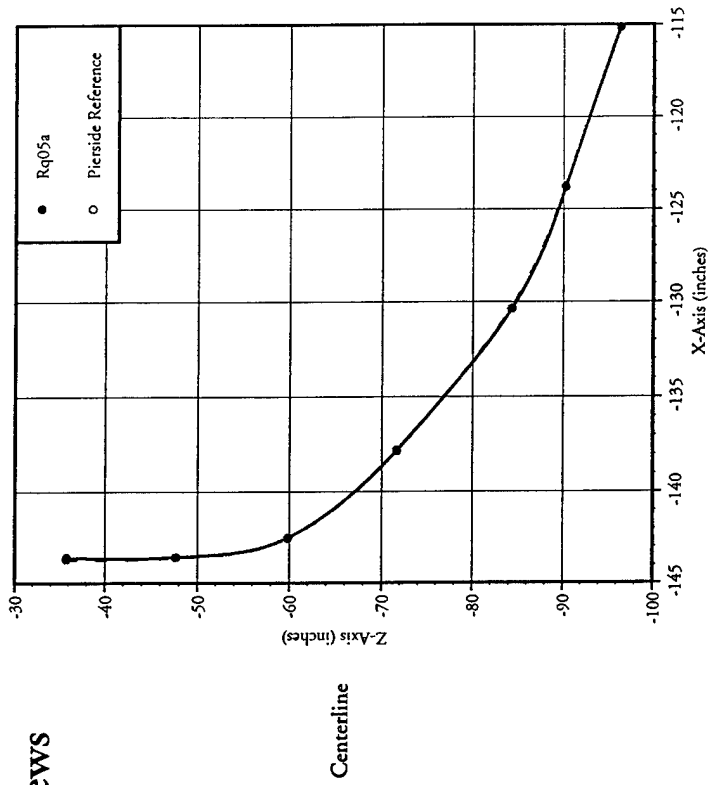

# Static Deflection Cross Sectional Views

## Data Run: RC05a

Speed: 5.9 Kts  
Sea State = 2

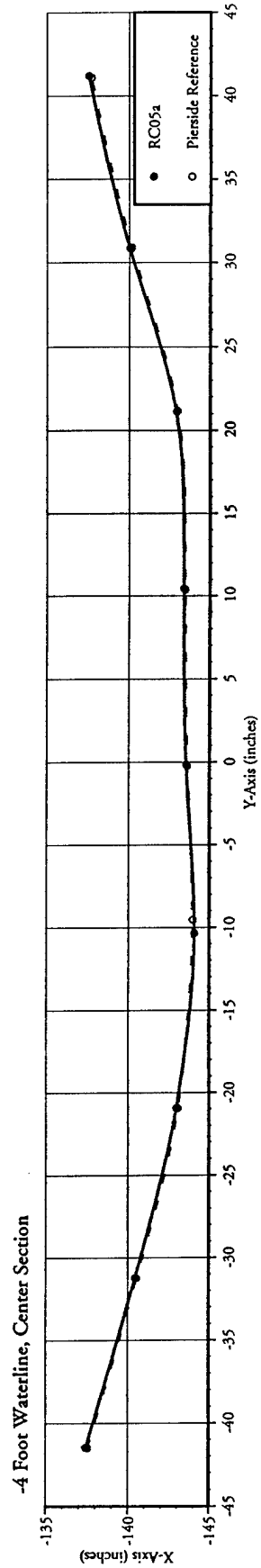
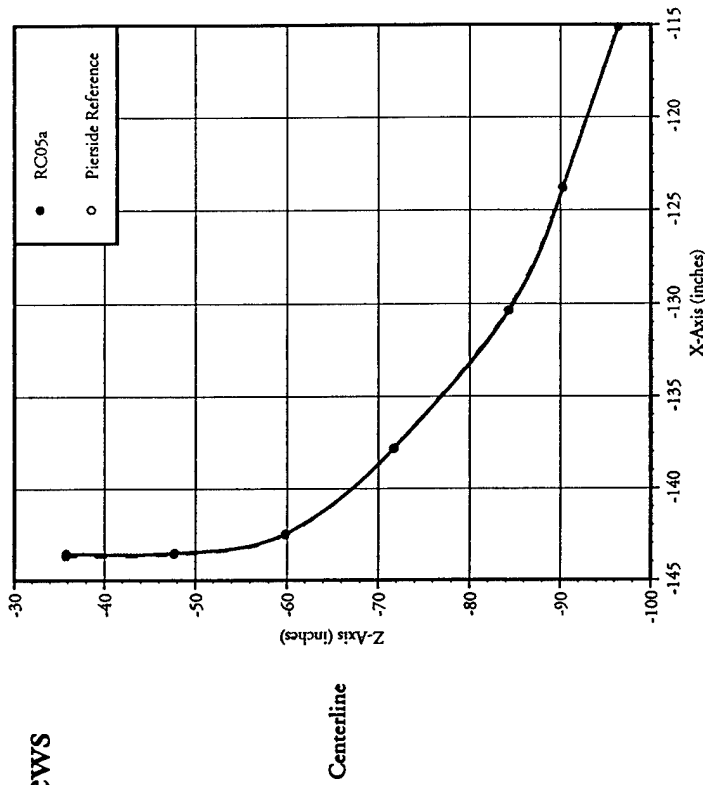

# Static Deflection Cross Sectional Views

## Data Run: Rn10b

Speed: 6.1 Kts

Sea State: 2

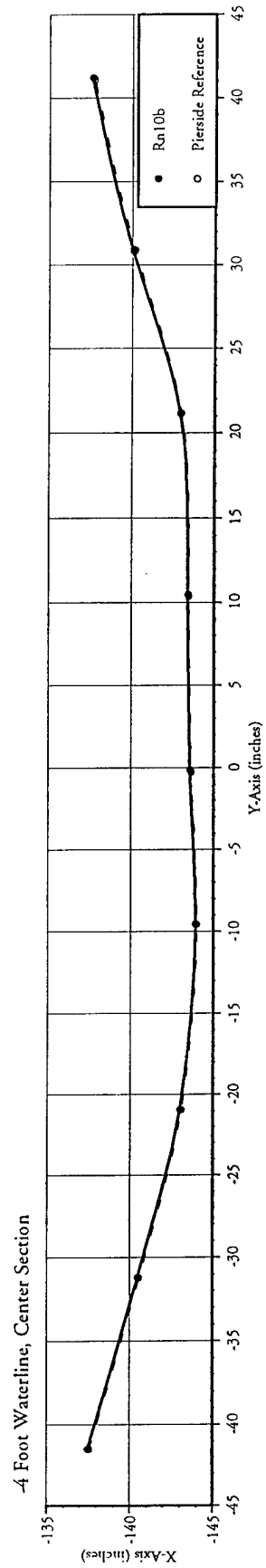
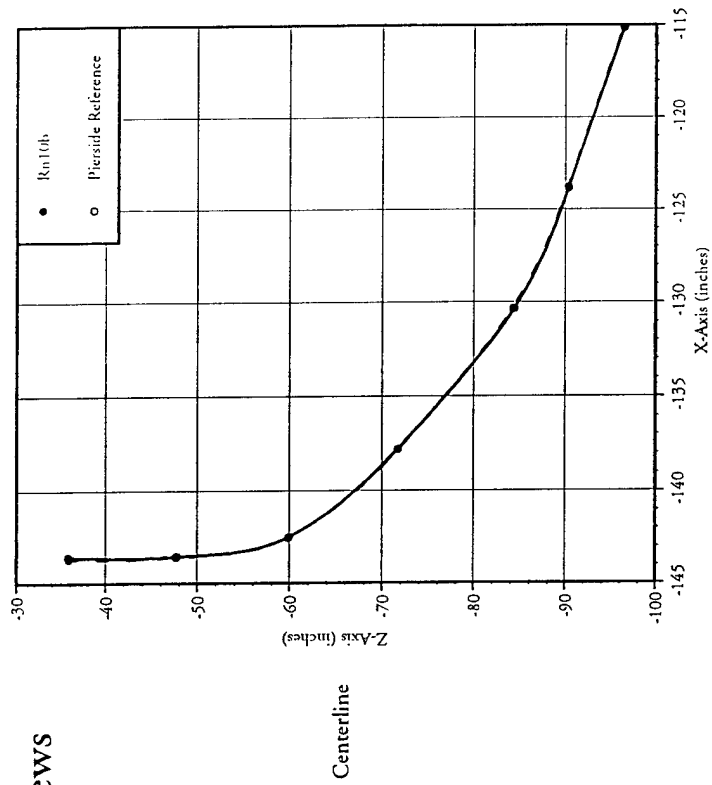

# Static Deflection Cross Sectional Views

Data Run: Rn06a

Speed: 6.3 Kts

Sea State: 2

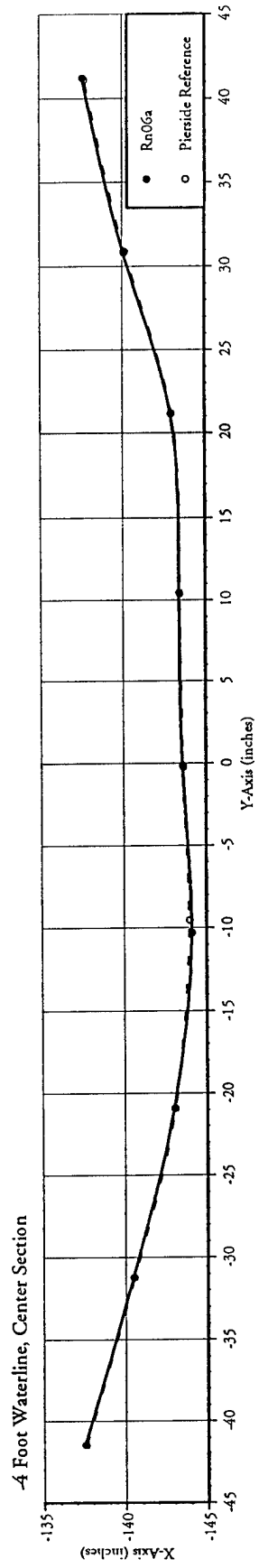
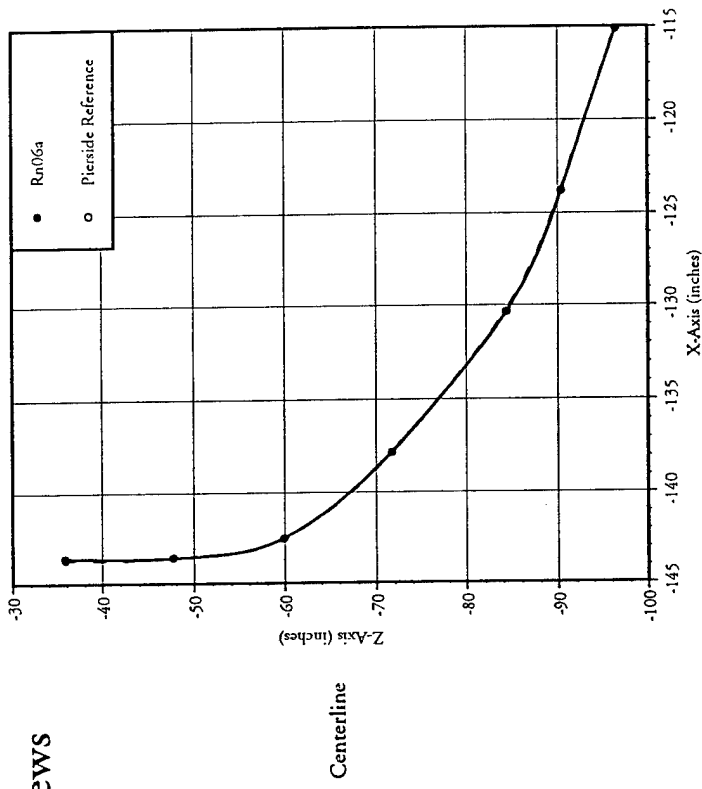

# Static Deflection Cross Sectional Views

## Data Run: Rp08a

Speed: 6.60 Kts

Sea State: 3

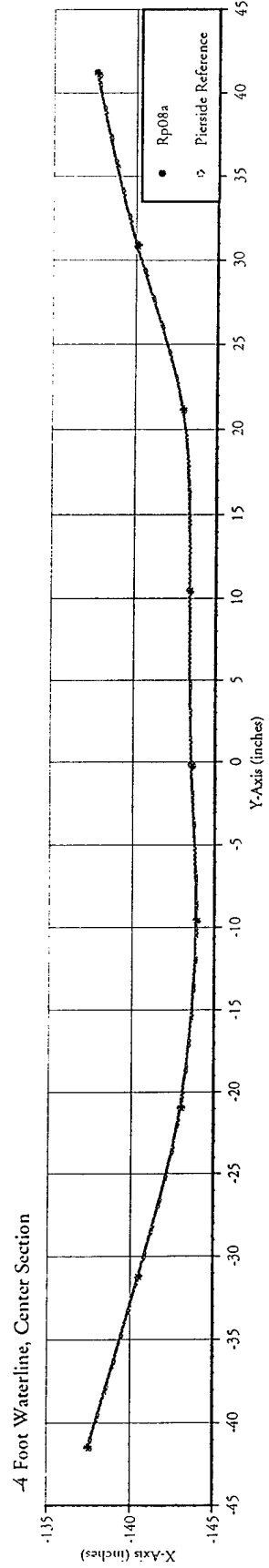
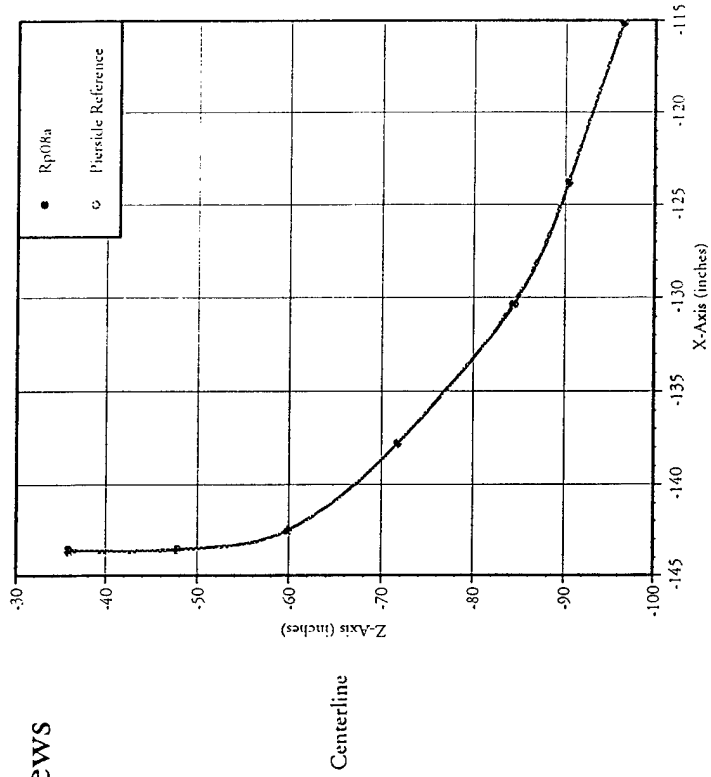

# Static Deflection Cross Sectional Views

## Data Run: Rt07a

Speed: 6.8 Kts

Sea State = 2

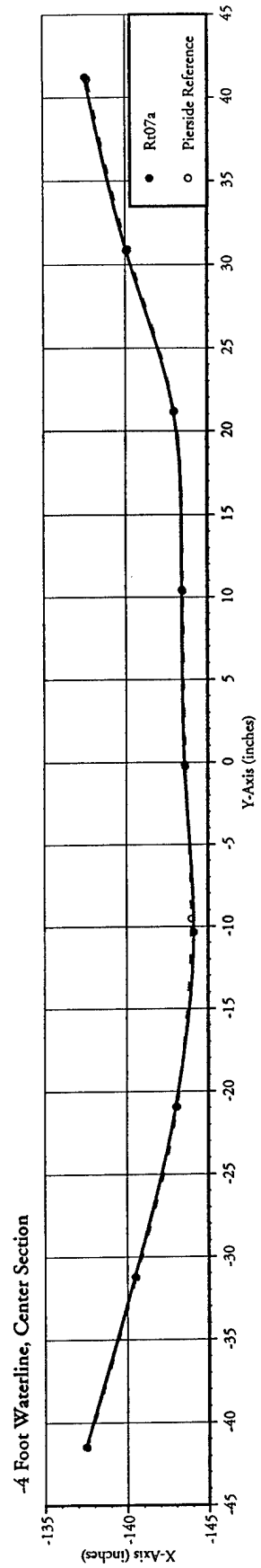
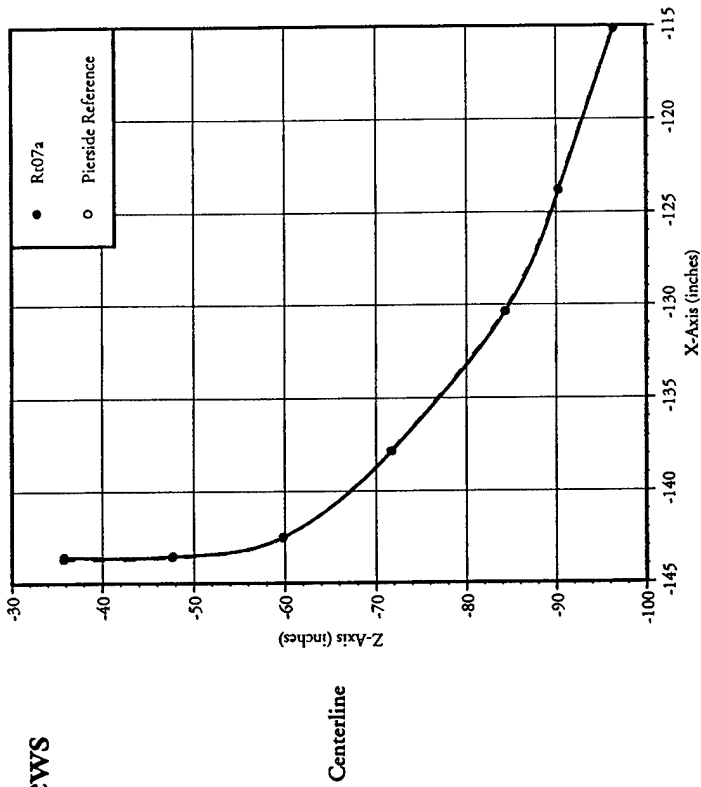

# Static Deflection Cross Sectional Views

## Data Run: Rn11a

Speed: 7.2 Kts  
Sea State = 2

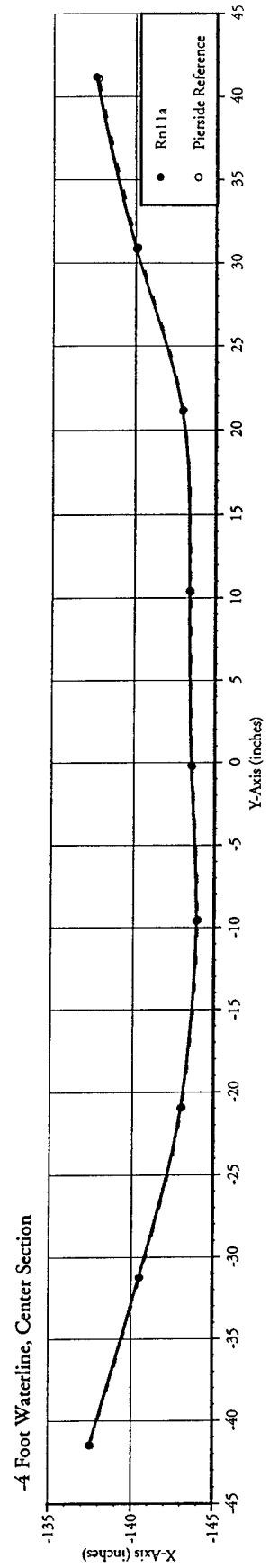
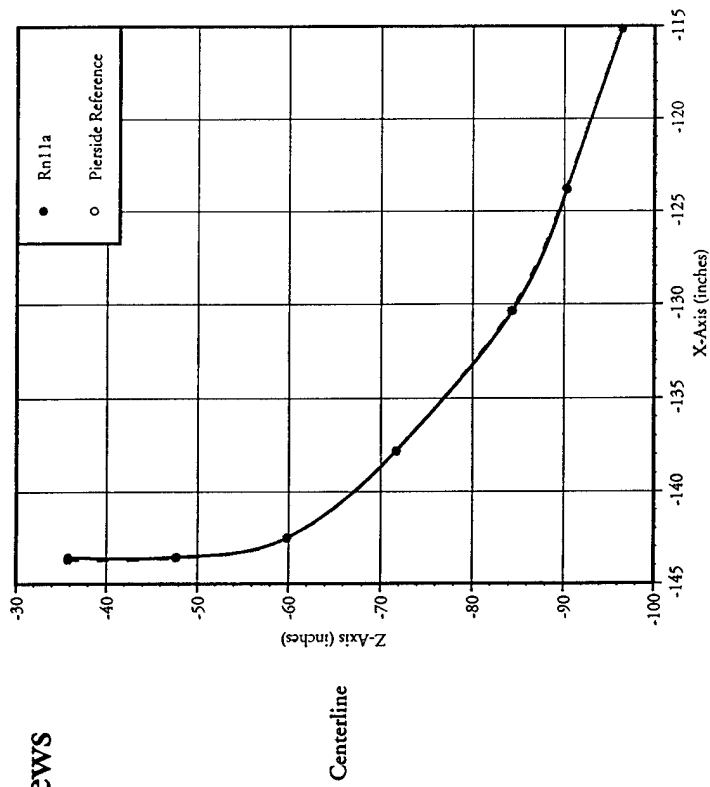

# Static Deflection Cross Sectional Views

## Data Run: Rp08b

Speed: 7.98 Kts  
Sea State: 3

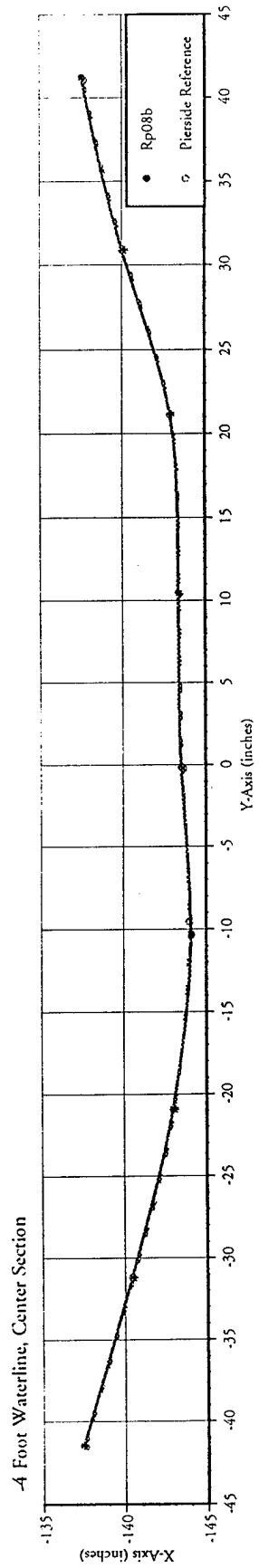
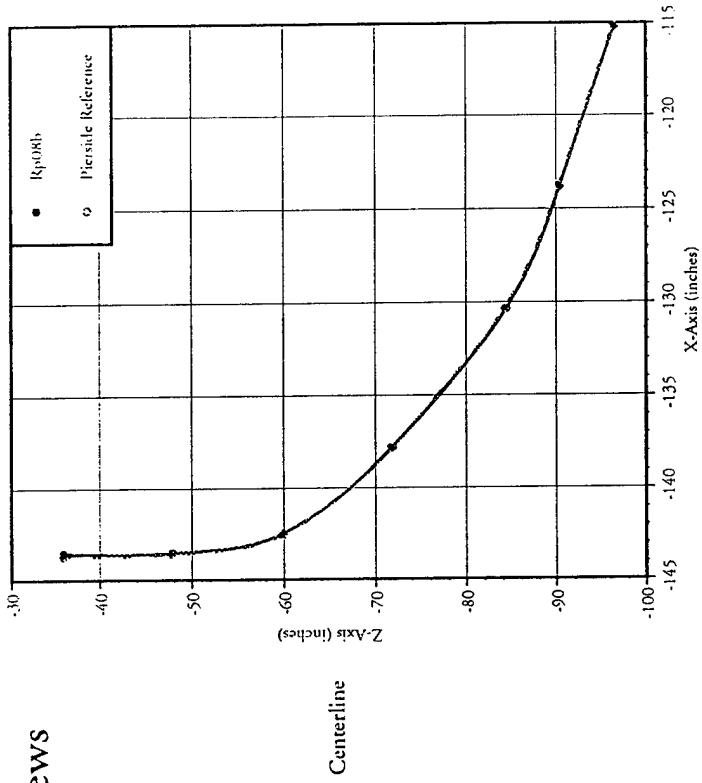



# Static Deflection Cross Sectional Views

## Data Run: RL09a

Speed: 8.8 Kts  
Sea State: 2

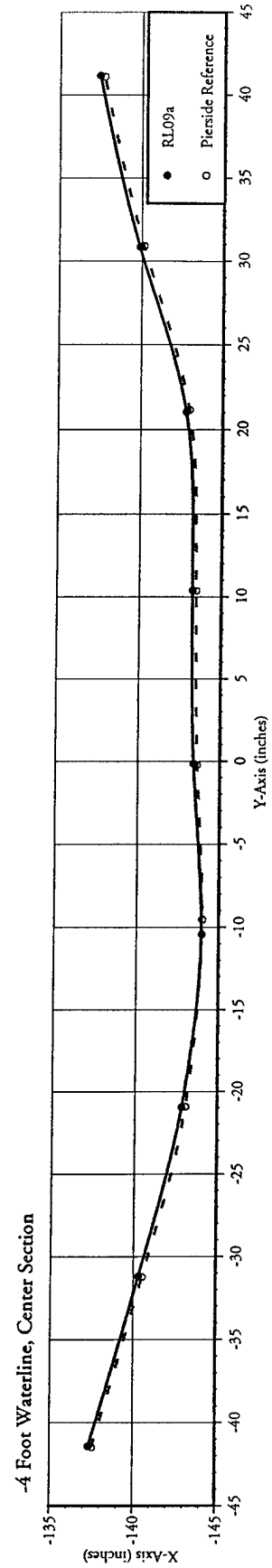
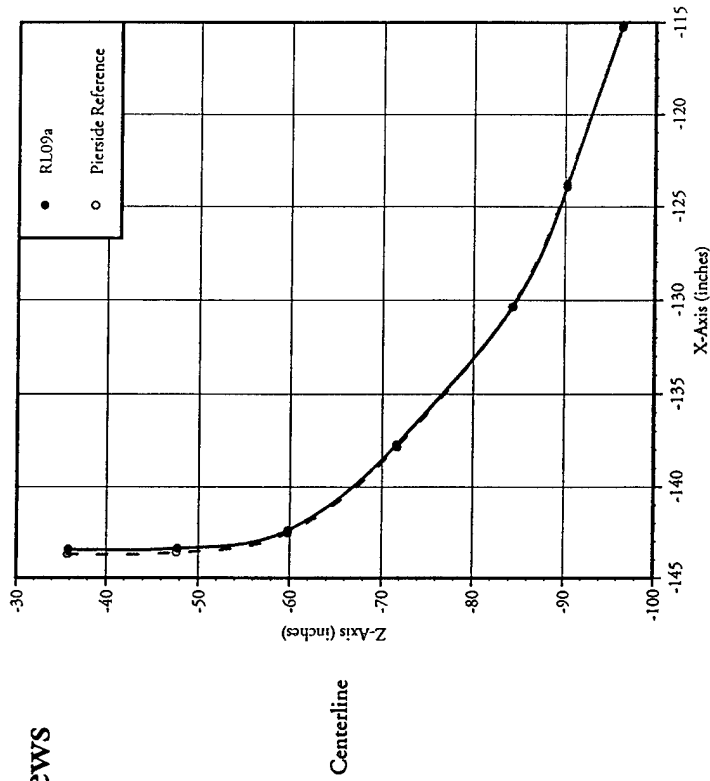

# Static Deflection Cross Sectional Views

Data Run: Rp09b

Speed: 9.37 Kts

Sea State: 3

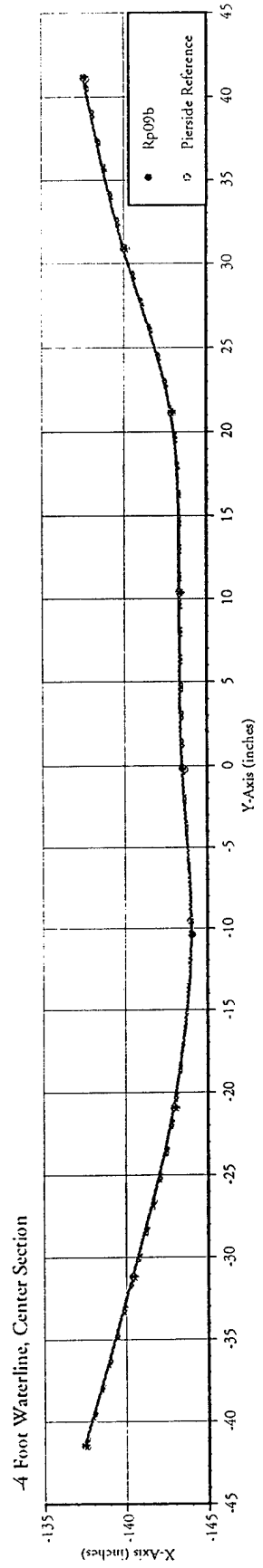
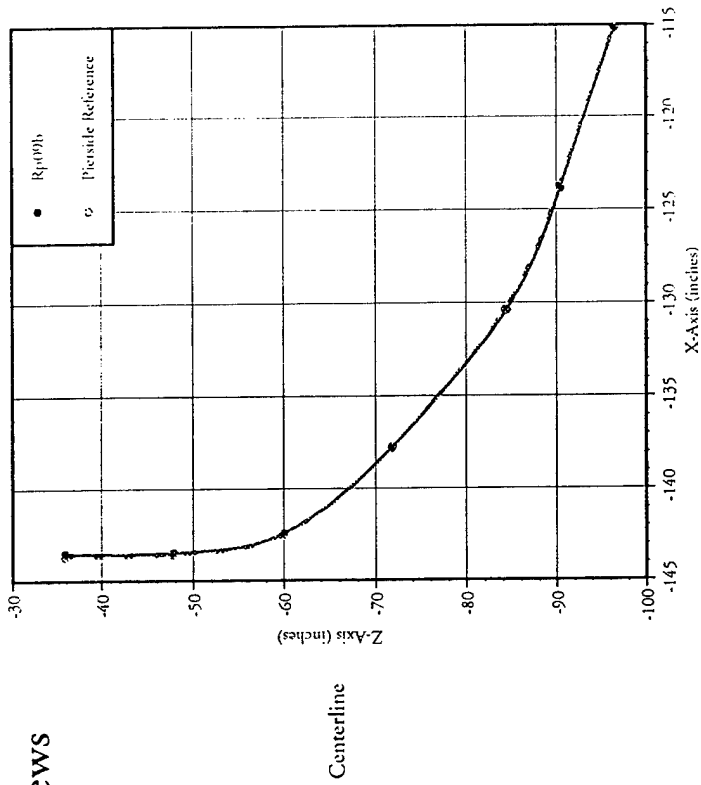

# Static Deflection Cross Sectional Views

## Data Run: Rt09a

Speed: 9.6 Kts

Sea State: 3

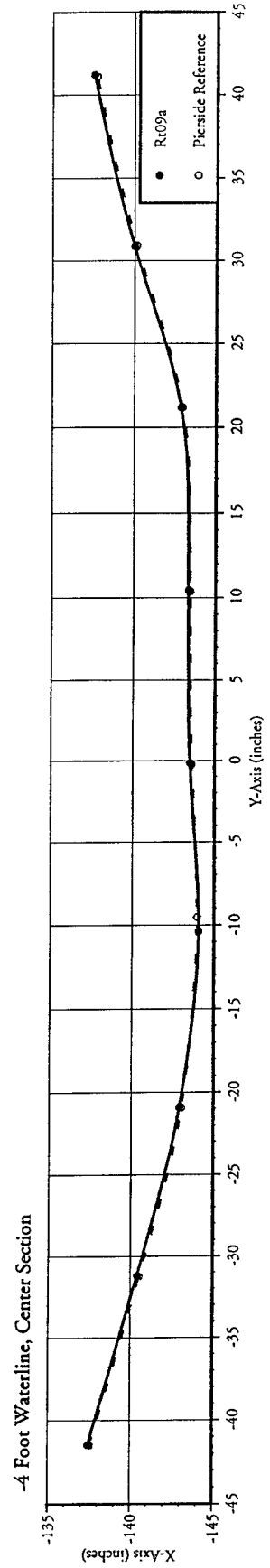
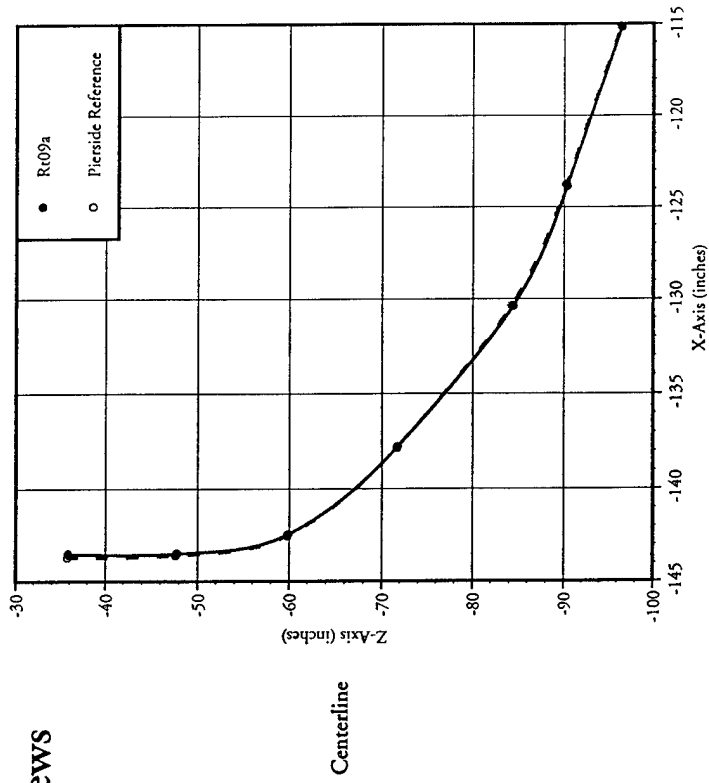

# Static Deflection Cross Sectional Views

## Data Run: Rt09b

Speed: 9.6 Kts

Sea State: 3

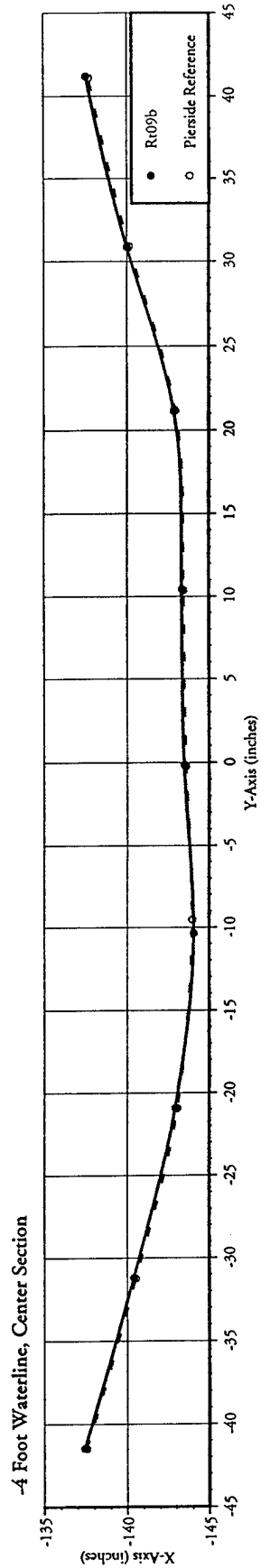
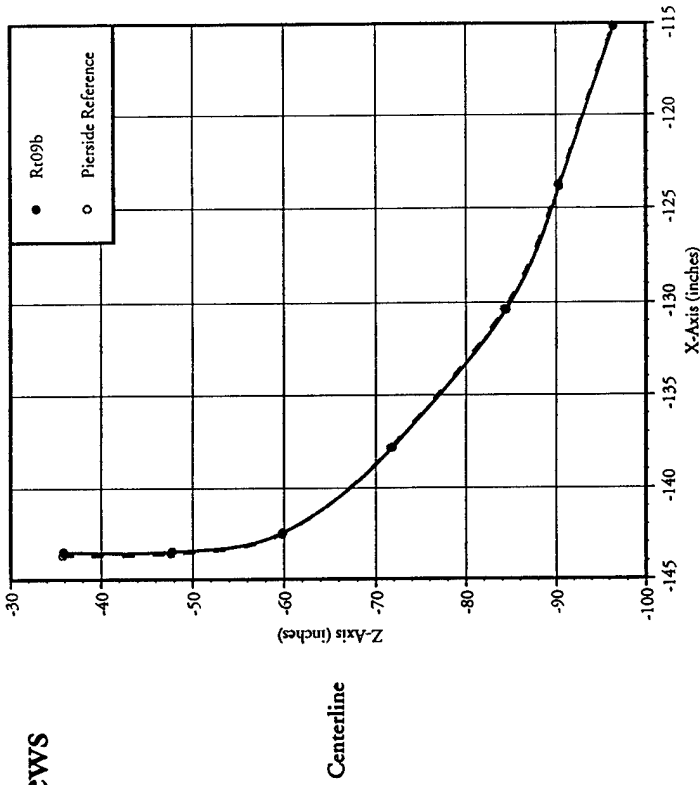

# Static Deflection Cross Sectional Views

## Data Run: Rp10a

Speed: 9.74 Kts  
Sea State: 2

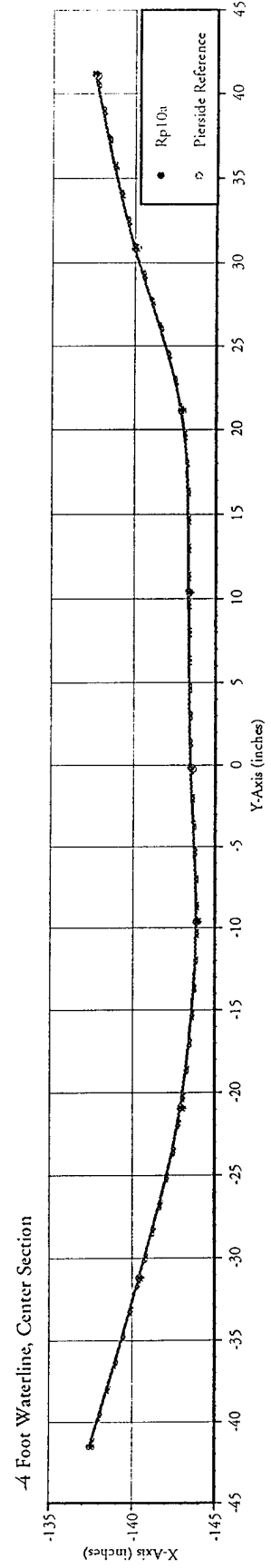
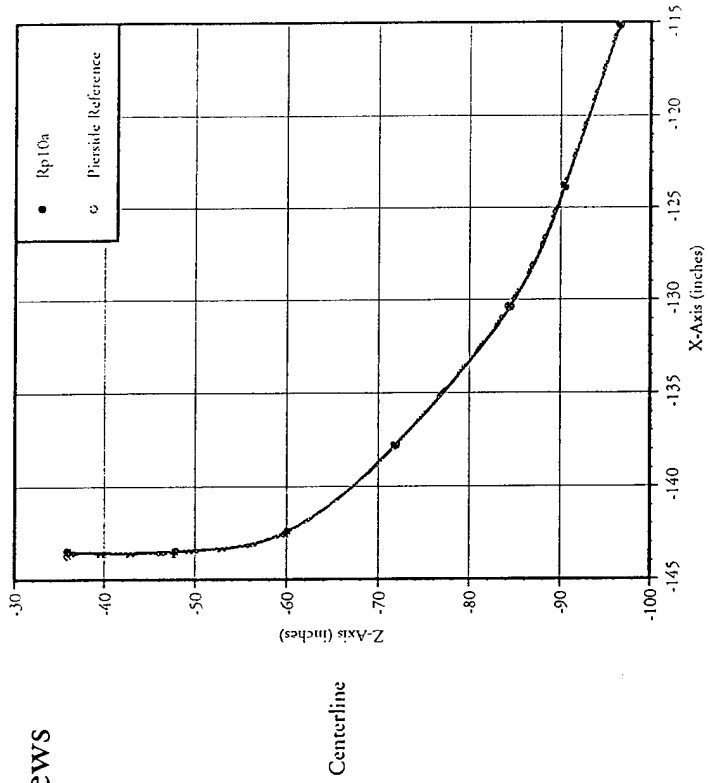

# Static Deflection Cross Sectional Views

## Data Run: RN10a

Speed: 10.2 Kts

Sea State: 2

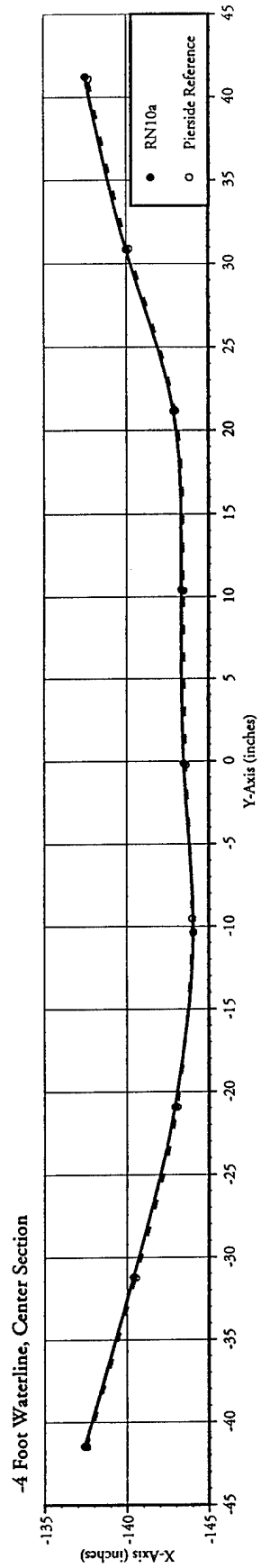
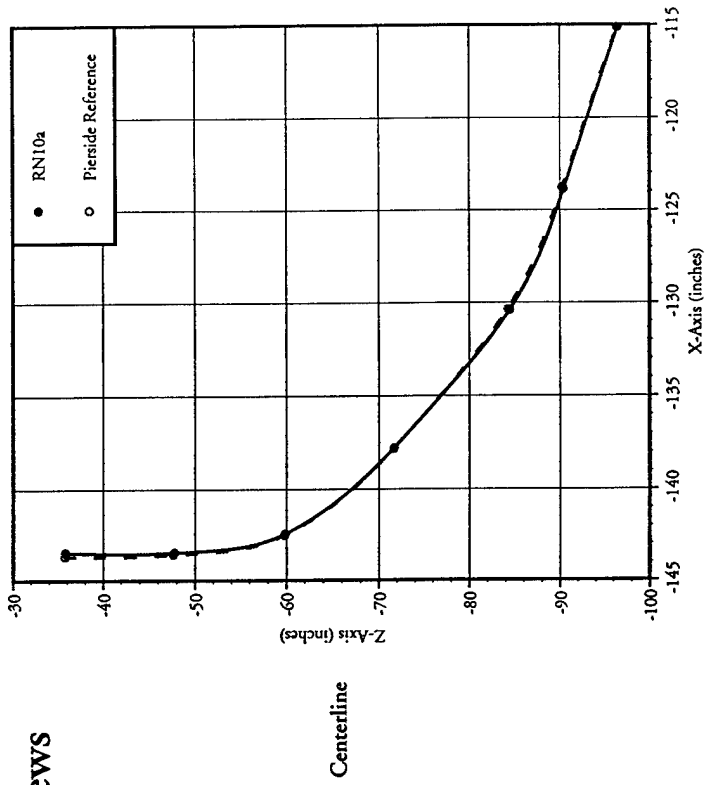

# Static Deflection Cross Sectional Views

## Data Run: CAL10

Speed: 10.3 Kts  
Sea State: 2

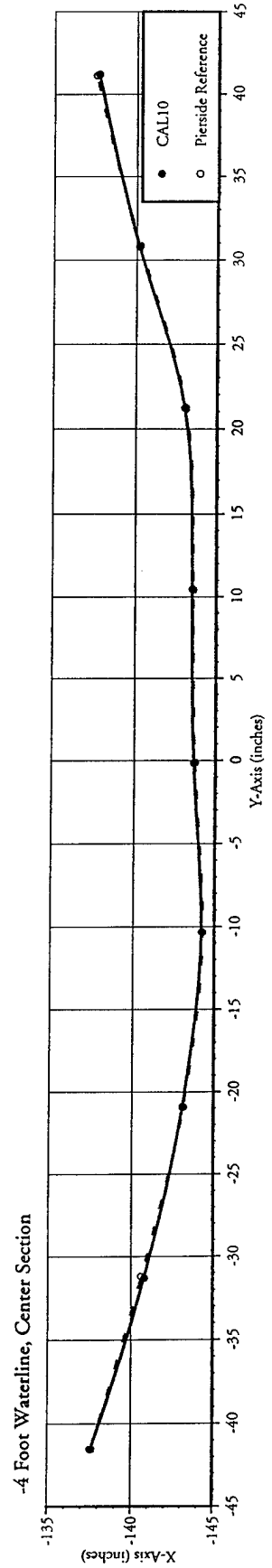
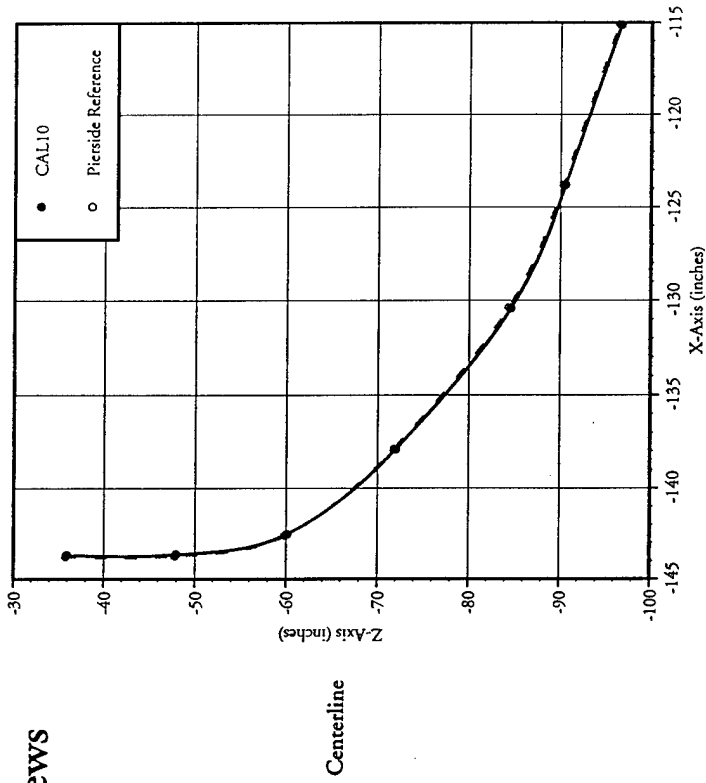

# Static Deflection Cross Sectional Views

## Data Run: RC10a

Speed: 10.4 Kts  
Sea State = 2

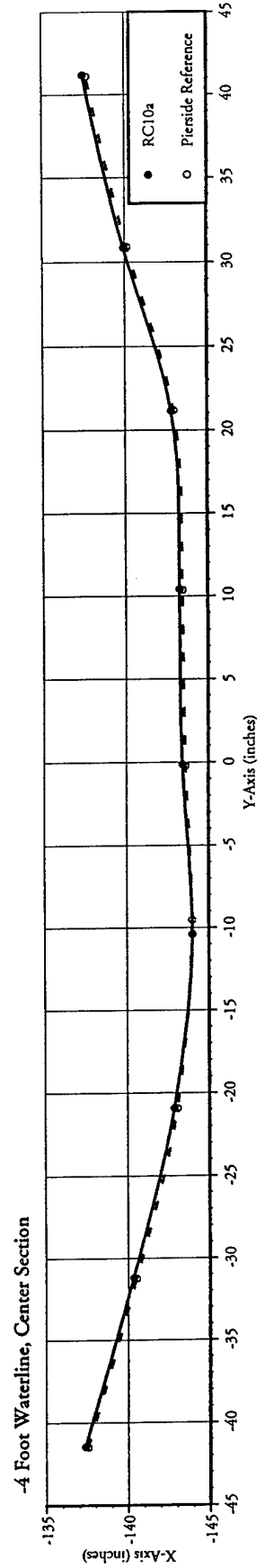
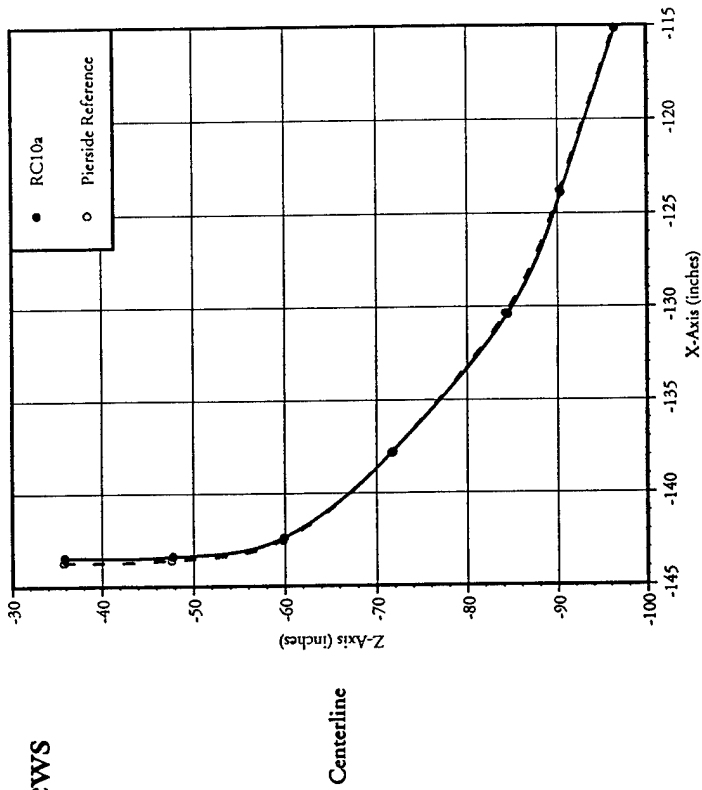



# Static Deflection Cross Sectional Views

## Data Run: Rp11a

Speed: 10.67 Kts

Sea State: 3

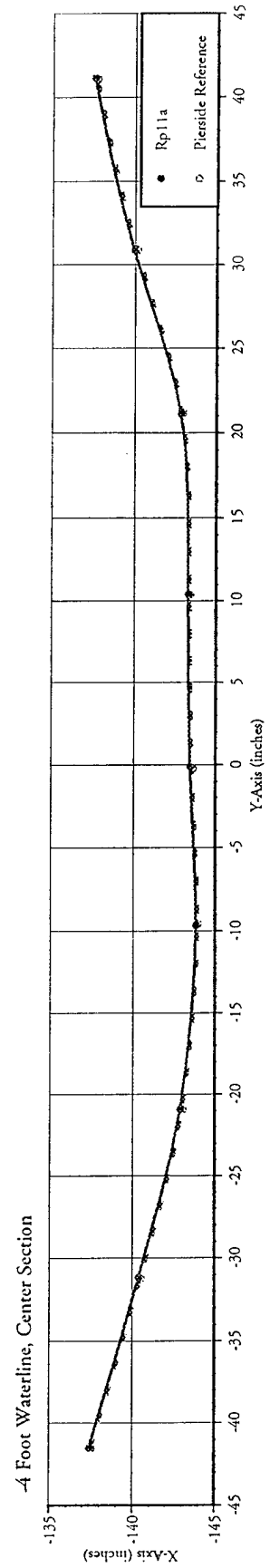
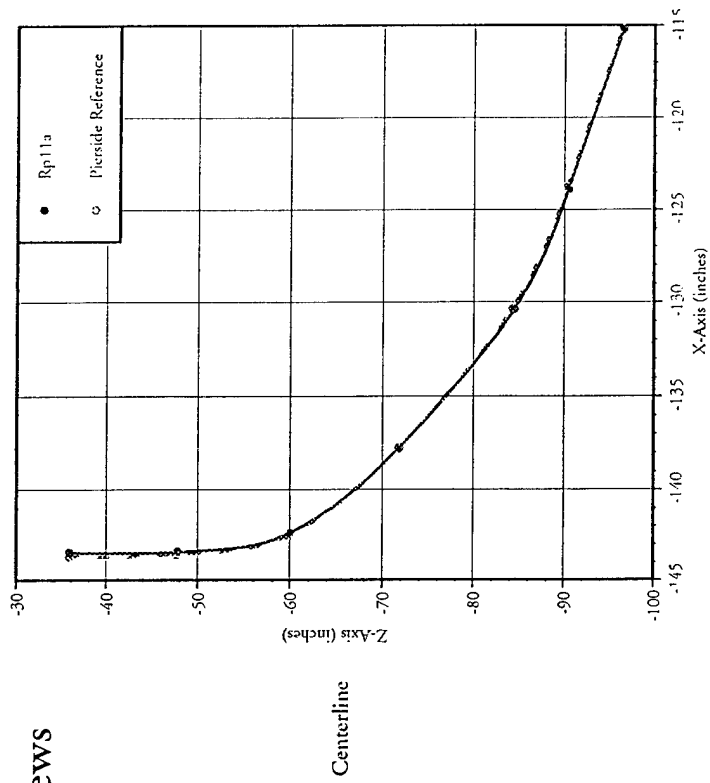

# Static Deflection Cross Sectional Views

Data Run: Rp09a

Speed: 10.99 Kts

Sea State: 3

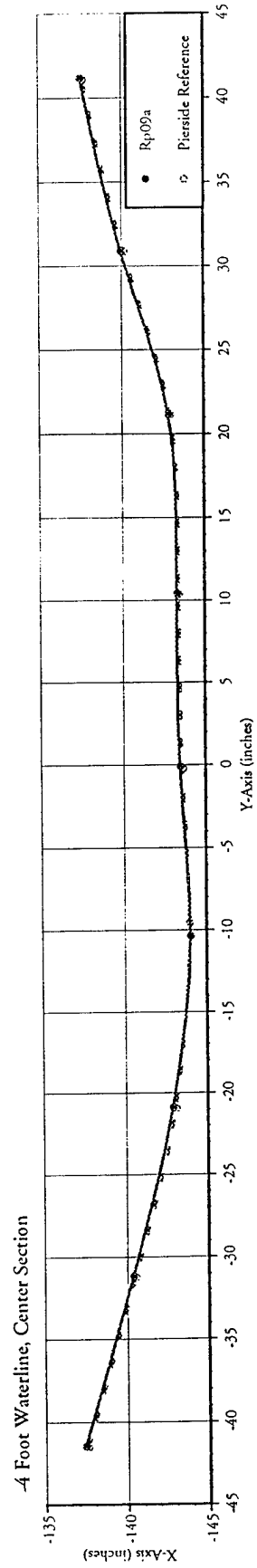
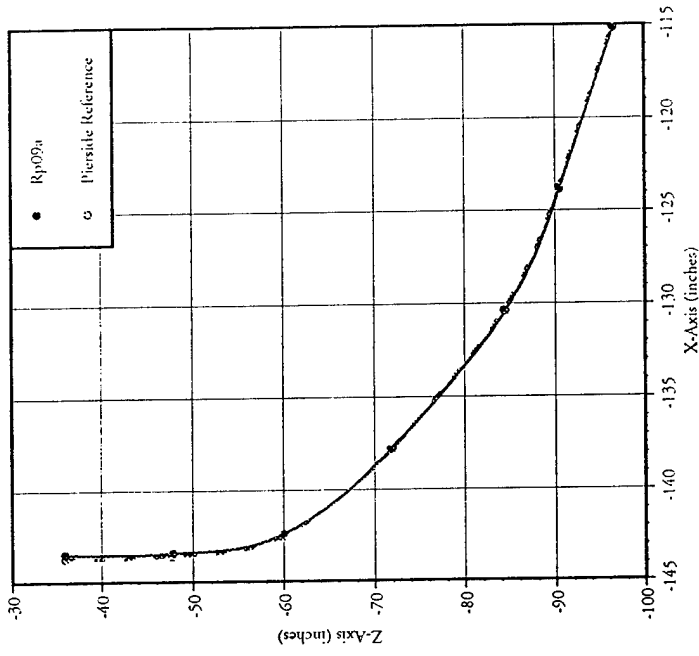

# Static Deflection Cross Sectional Views

## Data Run: Rt12a

Speed: 11.3Kts

Sea State: 3

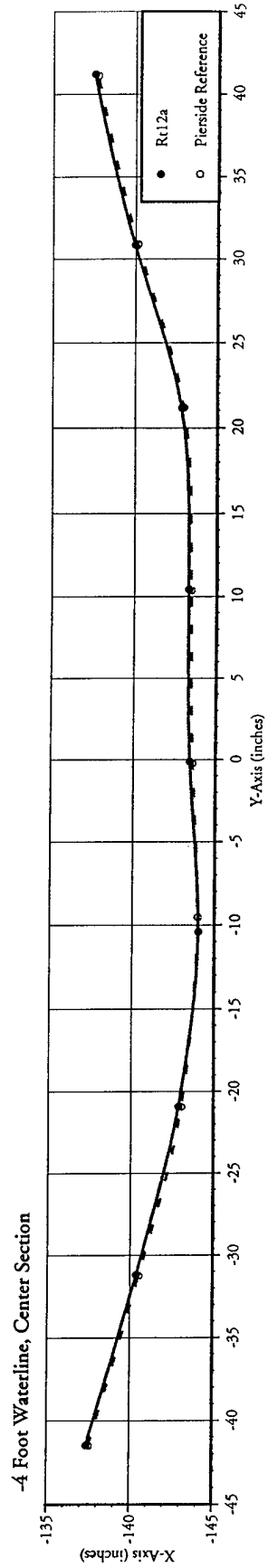
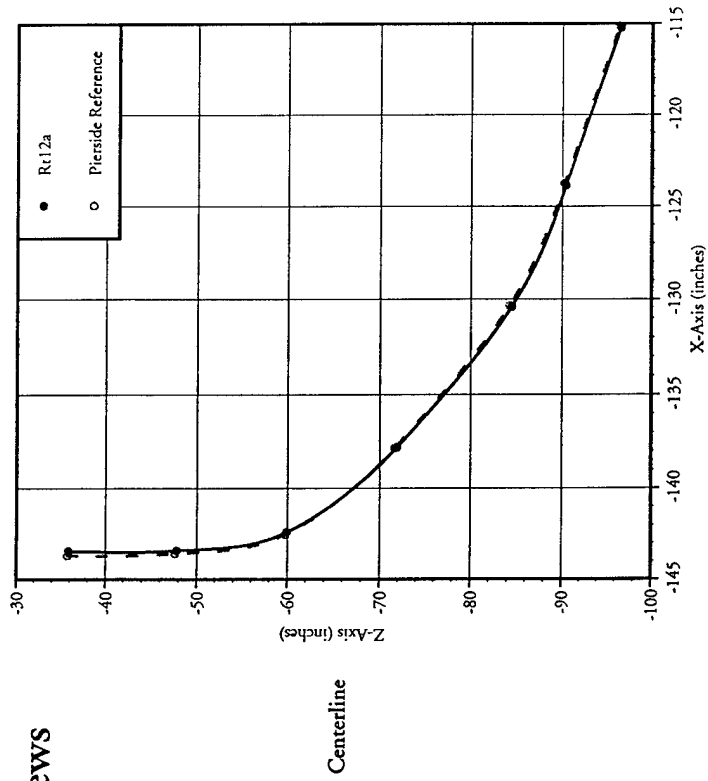

# Static Deflection Cross Sectional Views

Data Run: RL11a

Speed: 11.4 Kts

Sea State = 2

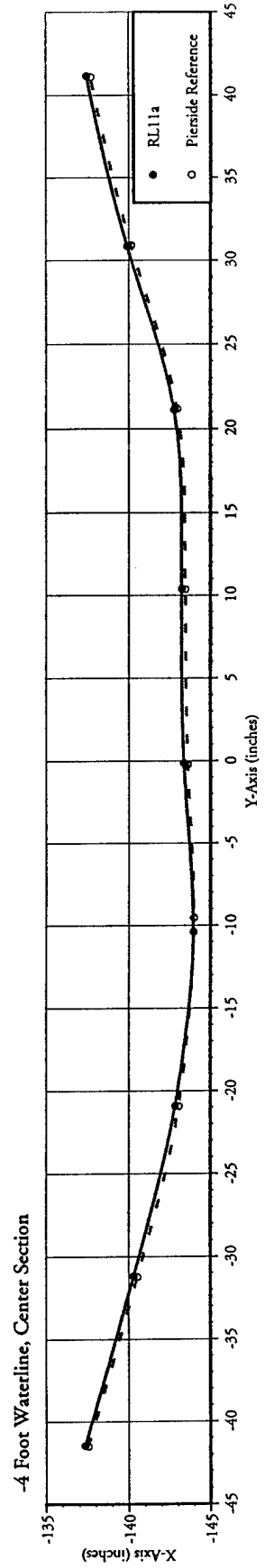
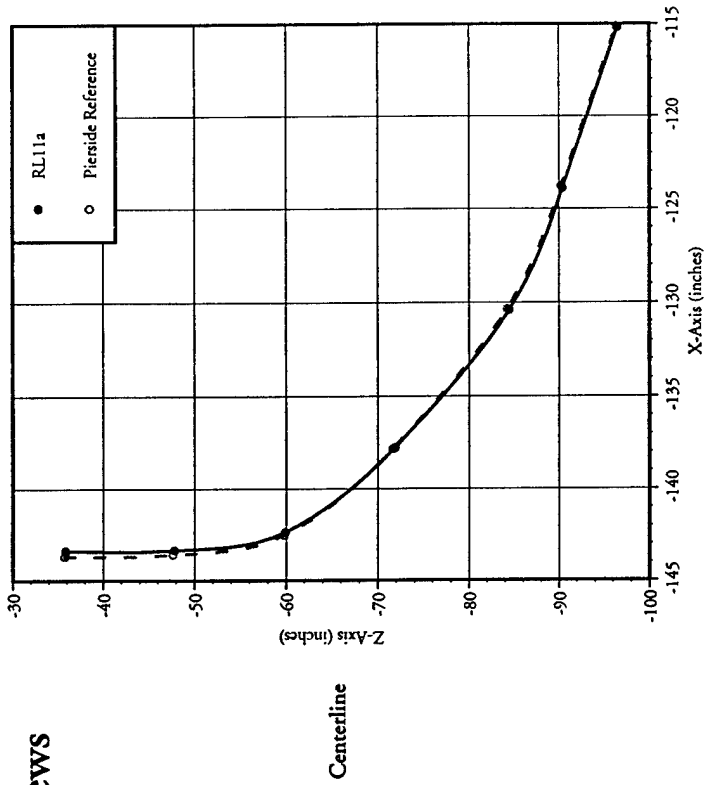

# Static Deflection Cross Sectional Views

## Data Run: Rt12b

Speed: 12.2Kts

Sea State: 2

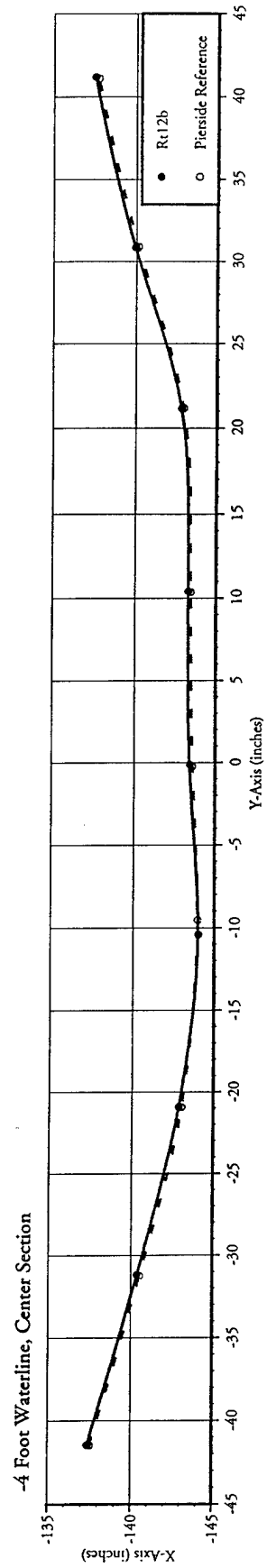
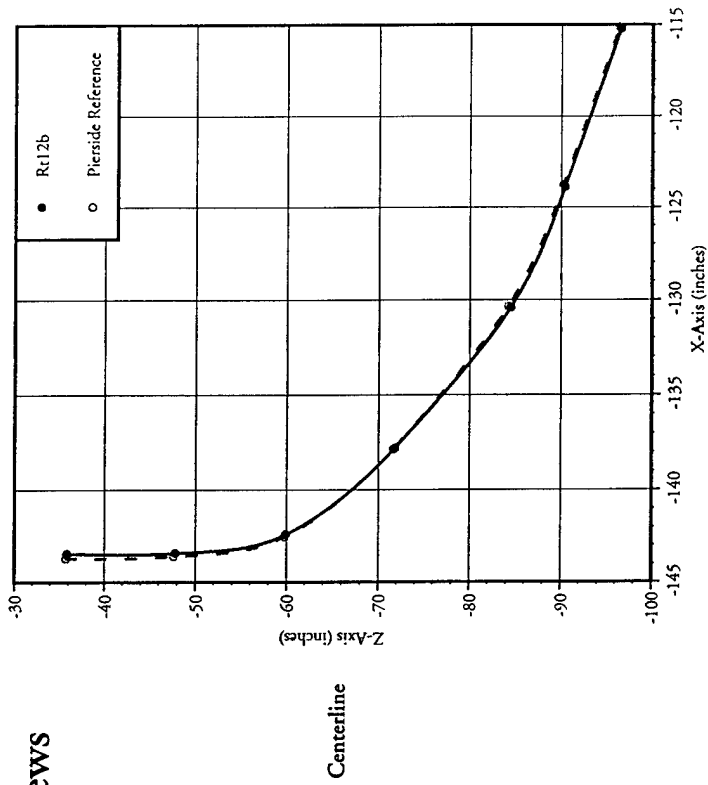

# Static Deflection Cross Sectional Views

Data Run: RL13c

Speed: 12.6 Kts

Sea State: 2

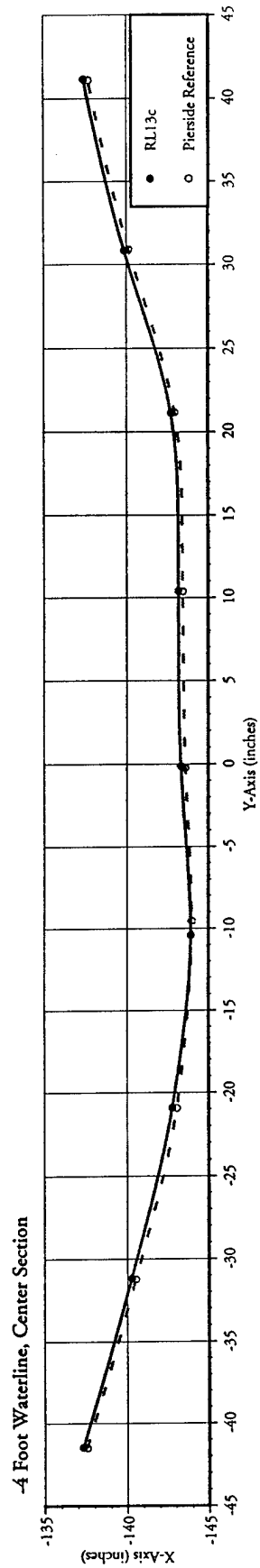
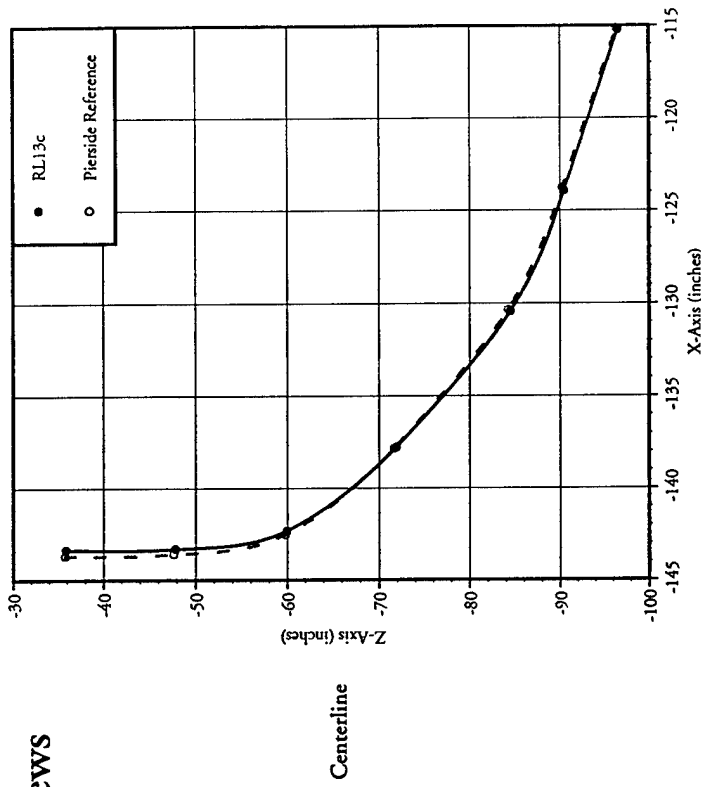

Static Deflection Cross Sectional Views  
 Data Run: RL14b  
 Speed: 12.9 Kts  
 Sea State = 2

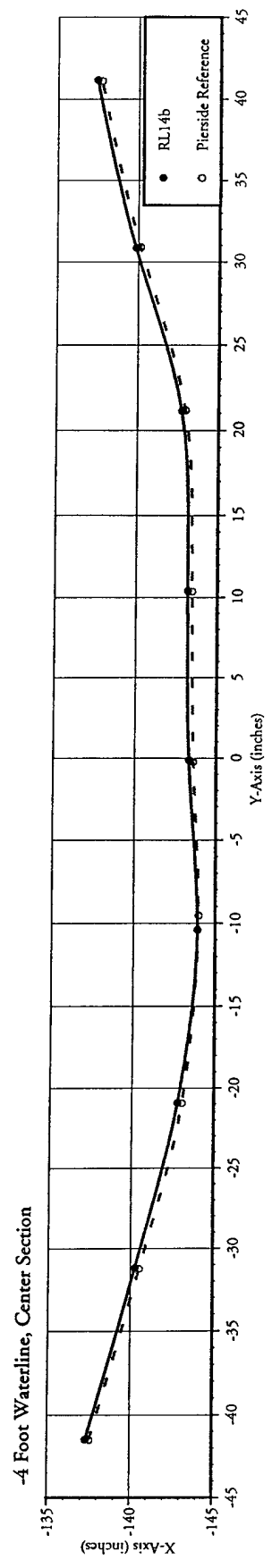
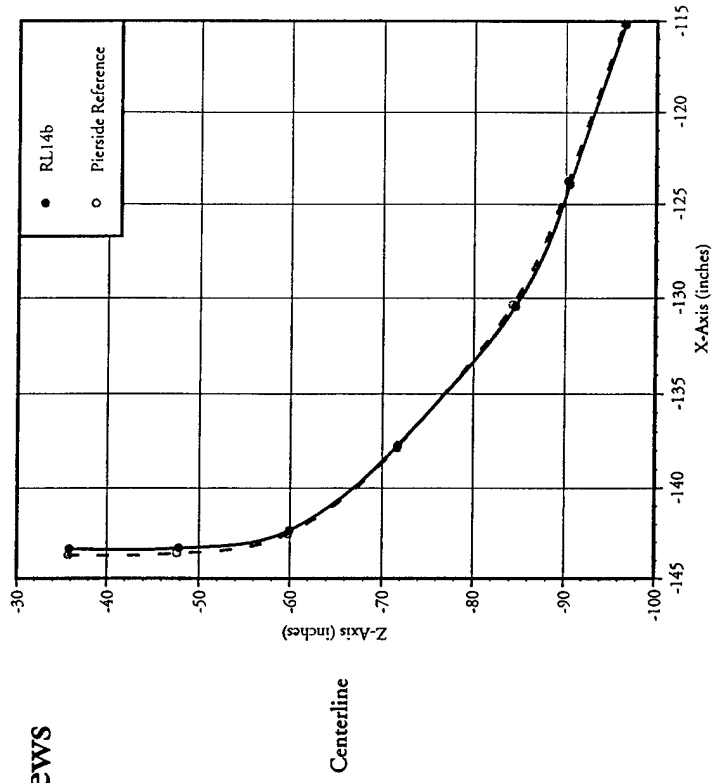

# Static Deflection Cross Sectional Views

Data Run: RL13a

Speed: 13.2 Kts

Sea State: 2

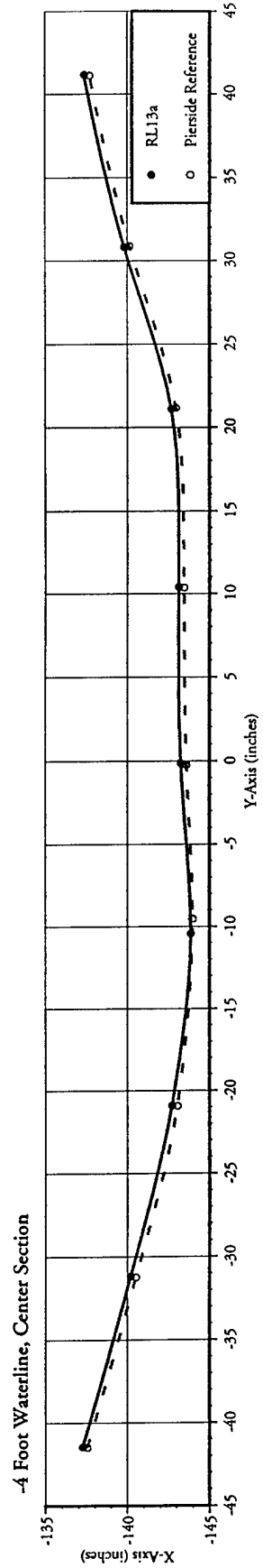
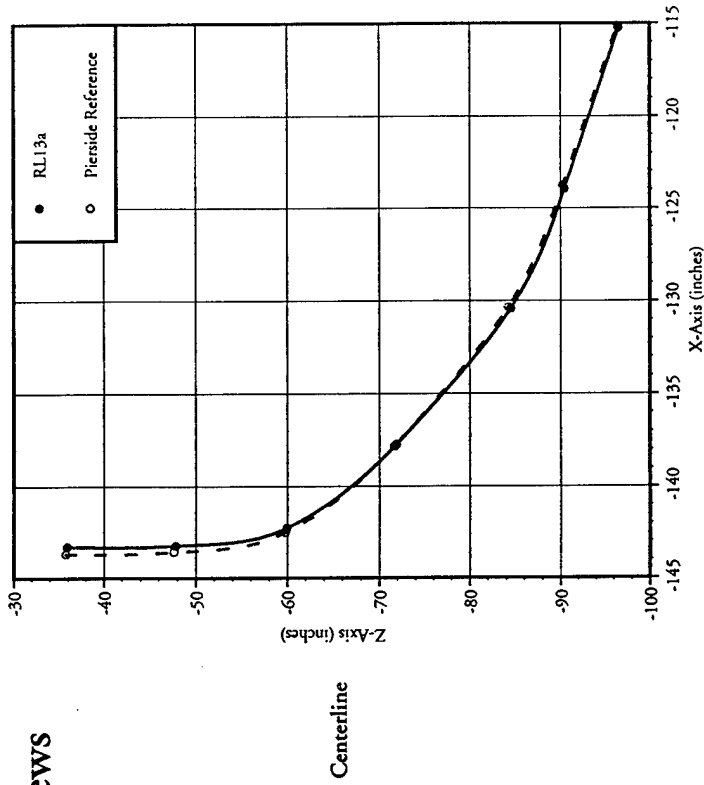



# Static Deflection Cross Sectional Views

Data Run: RL13b

Speed: 13.2 Kts

Sea State: 2

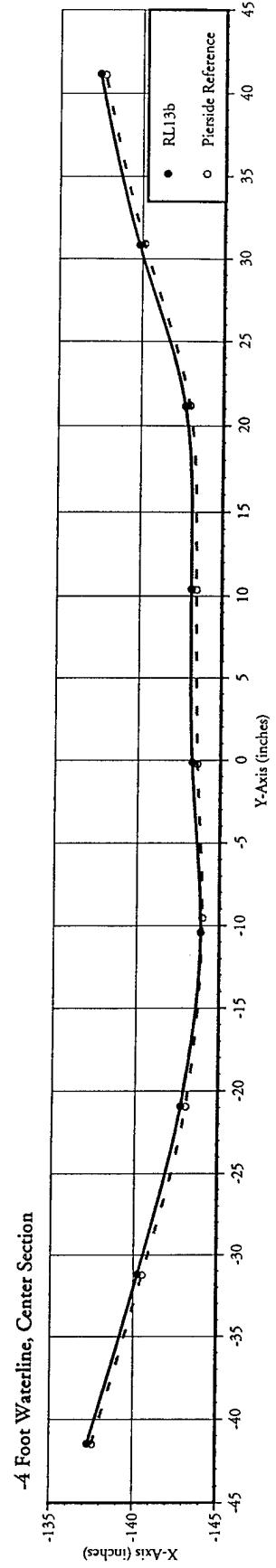
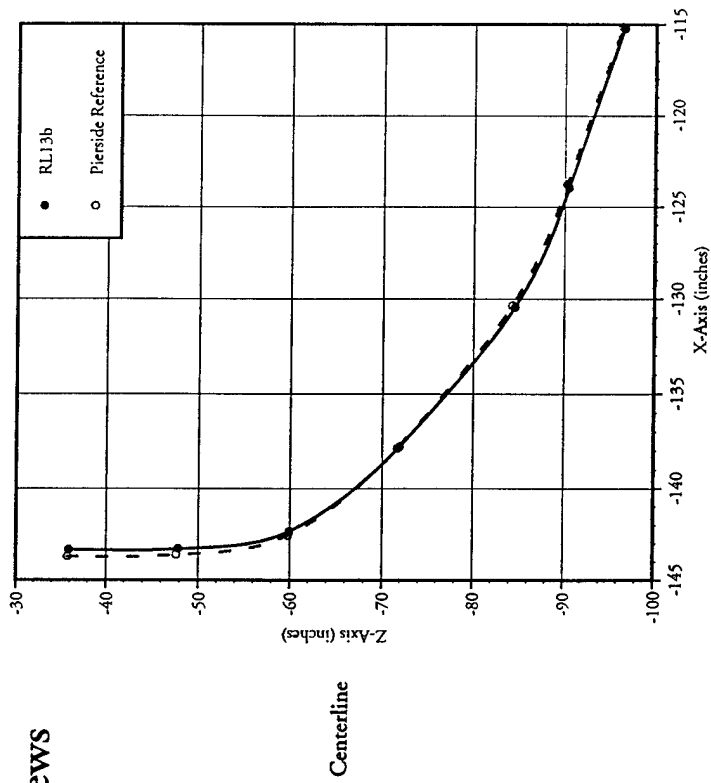

# Static Deflection Cross Sectional Views

## Data Run: RL15a

Speed: 13.6 Kts  
Sea State: 2

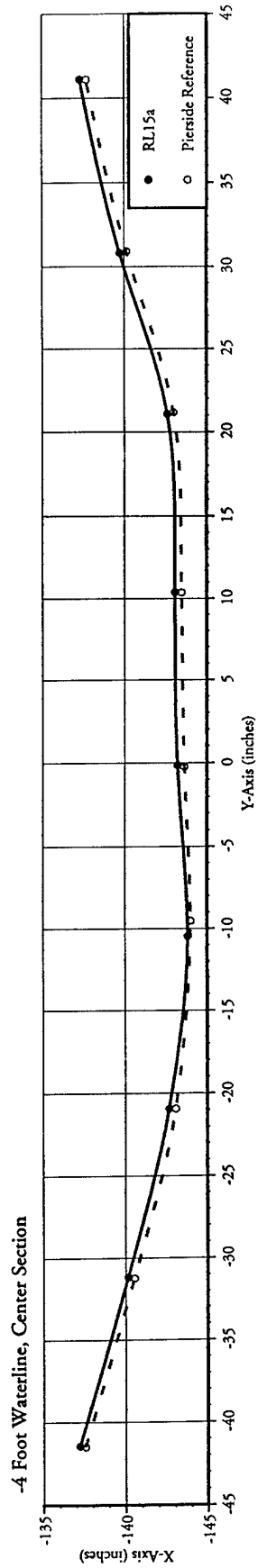
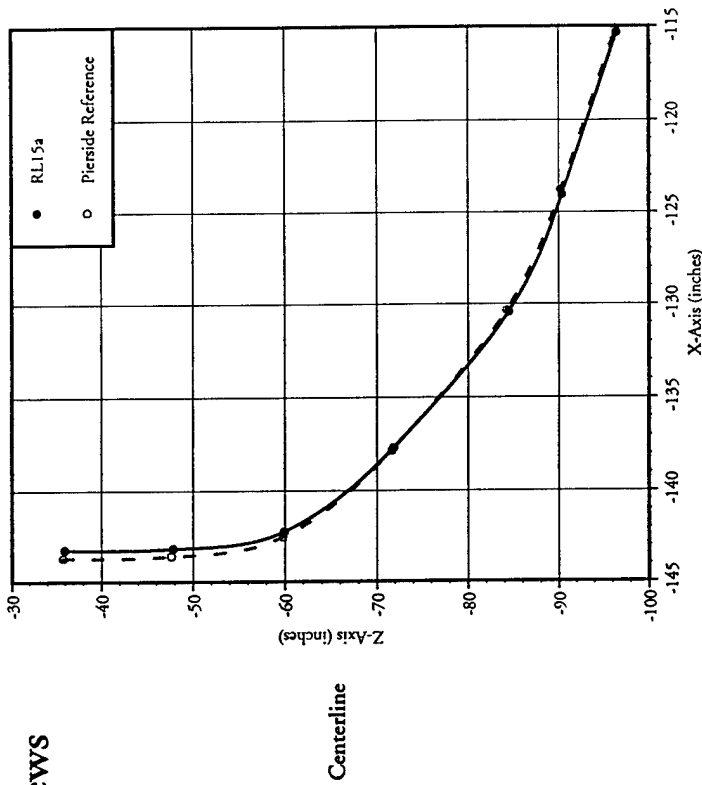

# Static Deflection Cross Sectional Views

## Data Run: Rp13a

Speed: 14.11 Kts  
Sea State: 3

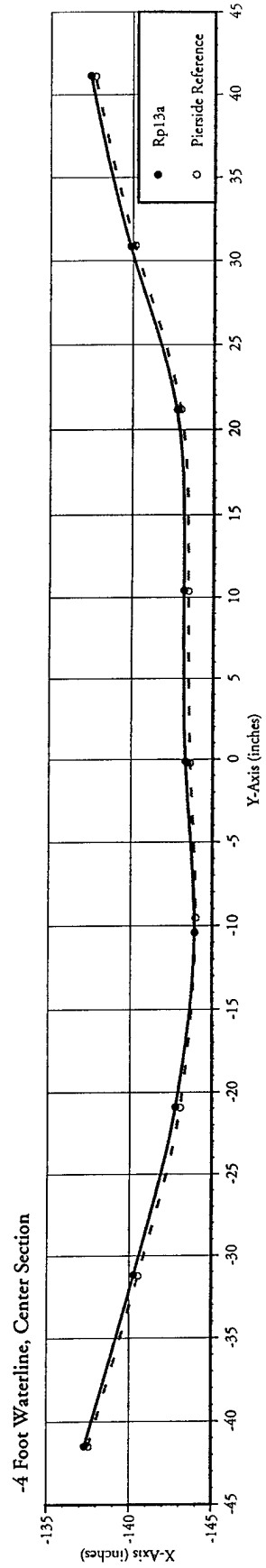
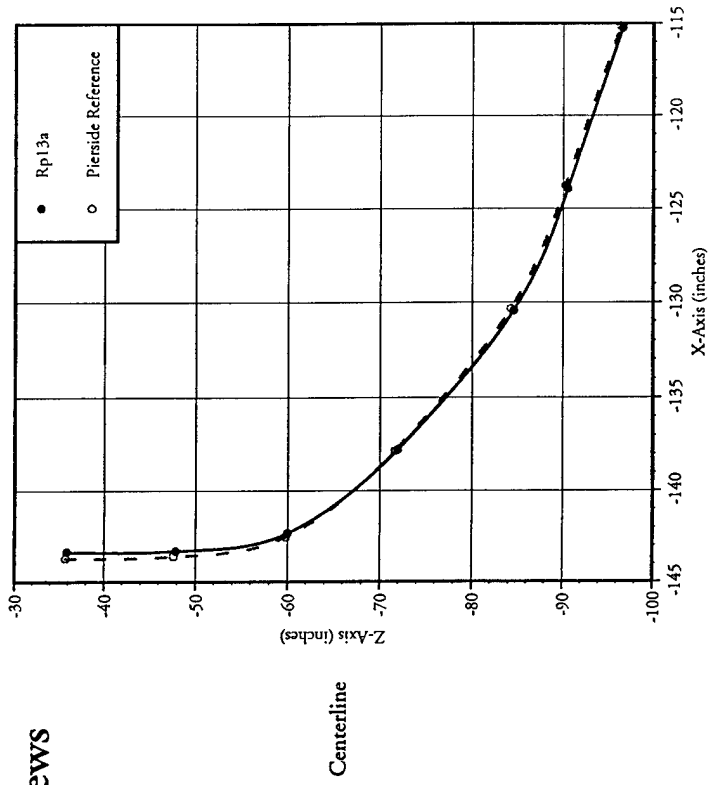

# Static Deflection Cross Sectional Views

## Data Run: RL14a

Speed: 14.3 Kts  
Sea State = 2

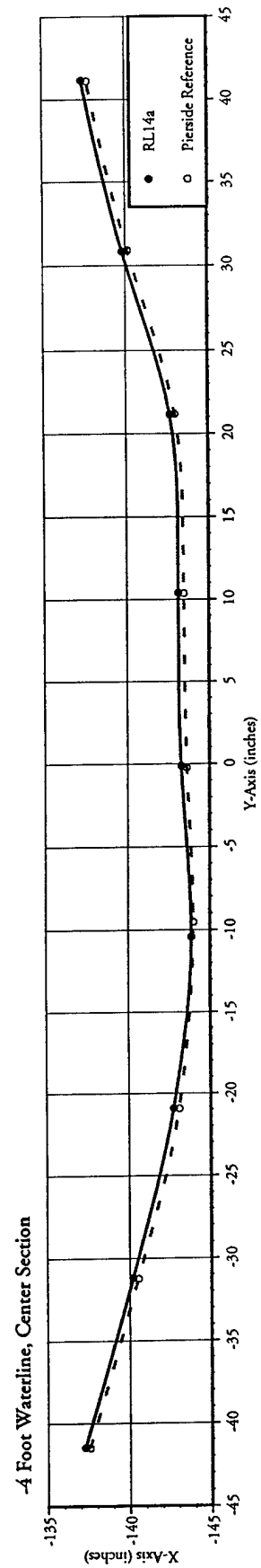
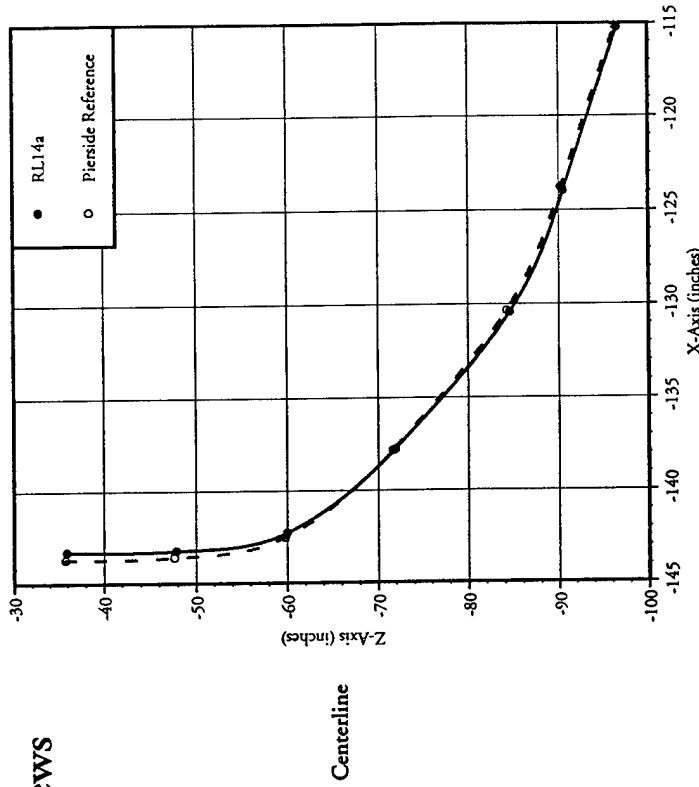

# Static Deflection Cross Sectional Views

## Data Run: RC15a

Speed: 15.4 Kts  
Sea State: 2

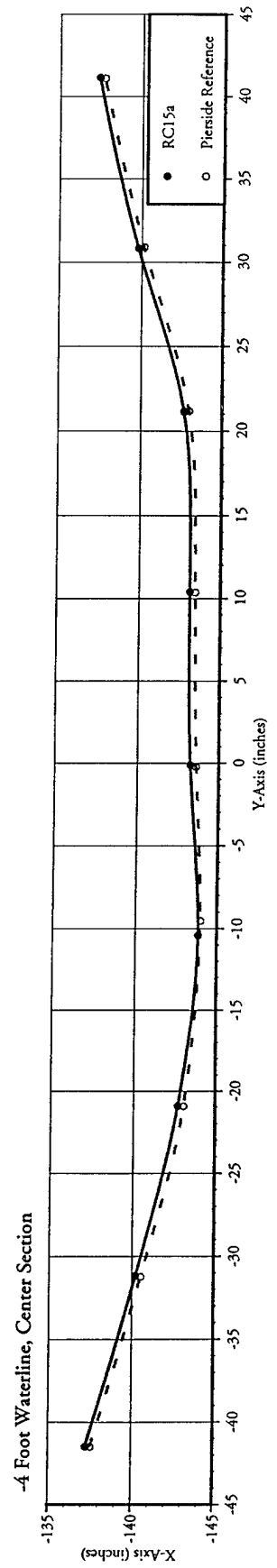
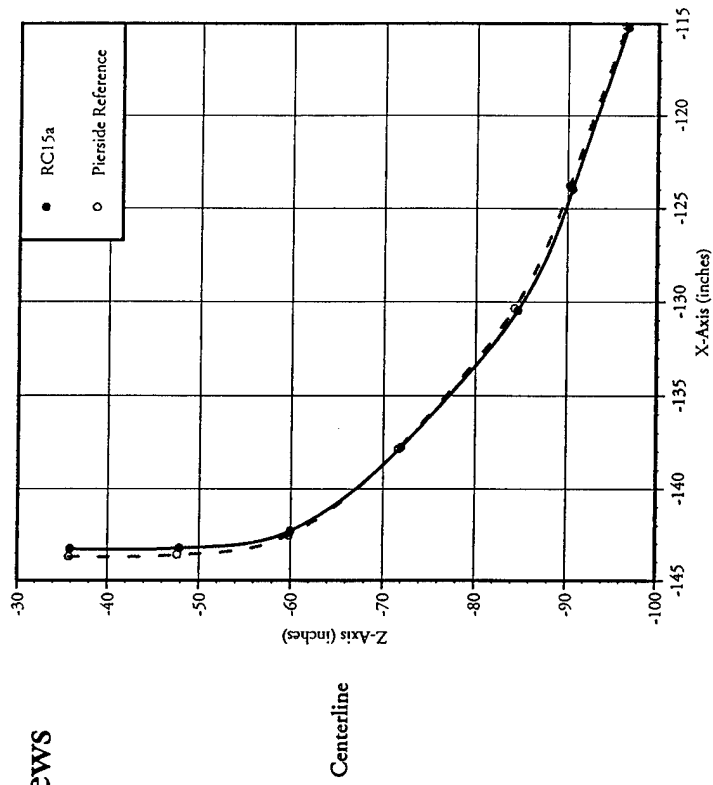

# Static Deflection Cross Sectional Views

Data Run: Rn15a

Speed: 15.4 Kts

Sea State = 2

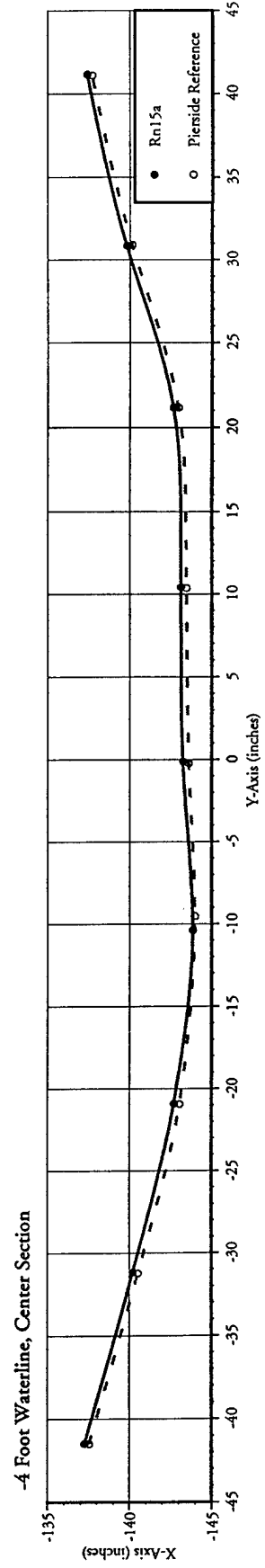
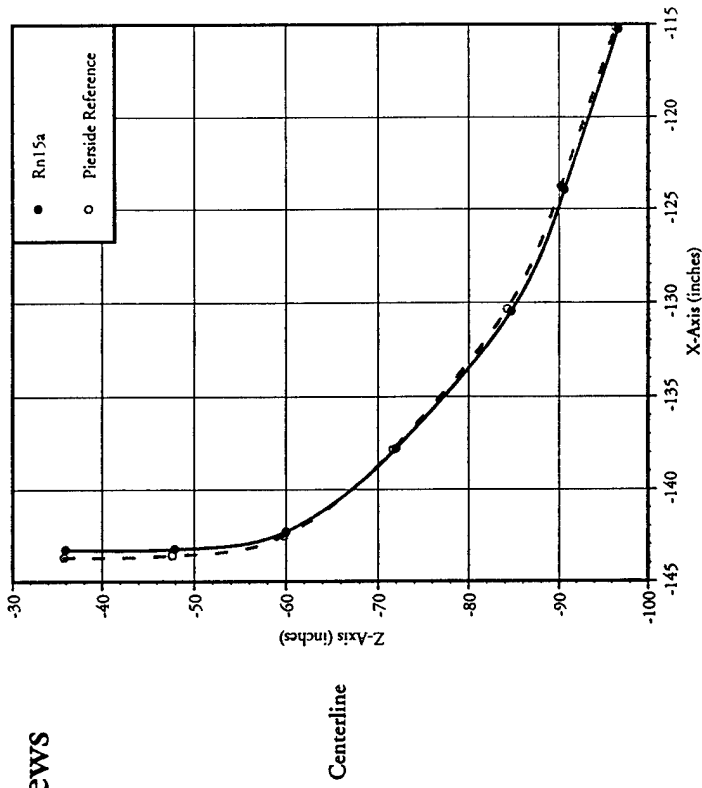

Static Deflection Cross Sectional Views  
 Data Run: Rn15b  
 Speed: 15.4 Kts  
 Sea State: 3

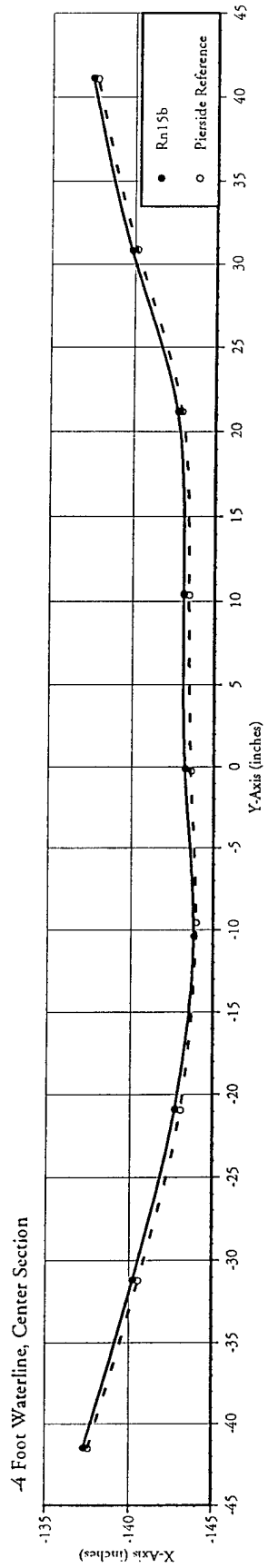
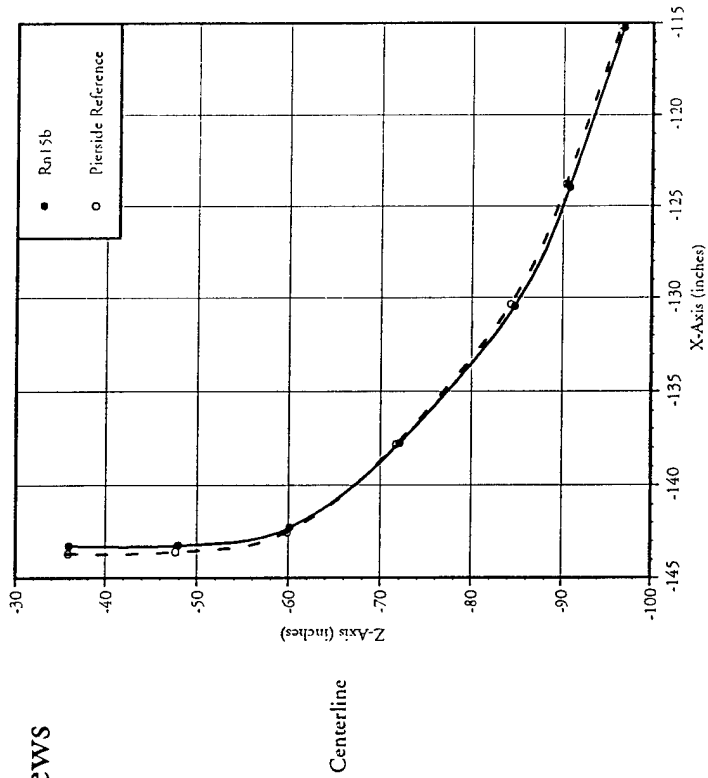

# Static Deflection Cross Sectional Views

## Data Run: CAL15b

Speed: 15.5 Kts

Sea State: 2

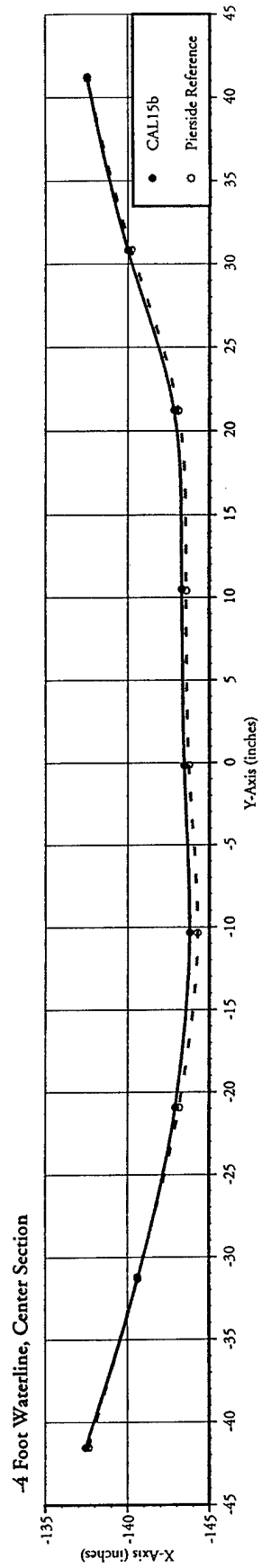
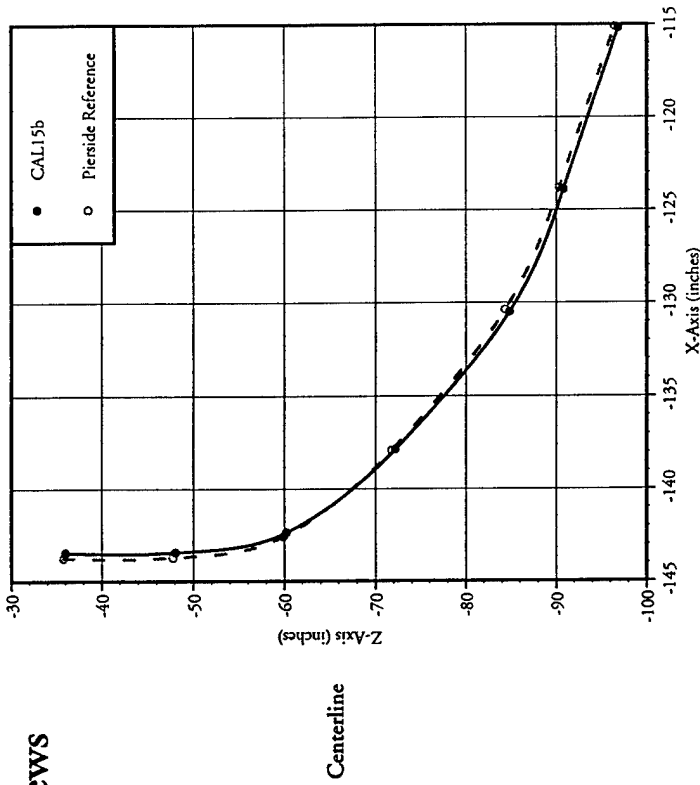



# Static Deflection Cross Sectional Views

Data Run: Rt16a

Speed: 15.8Kts

Sea State: 3

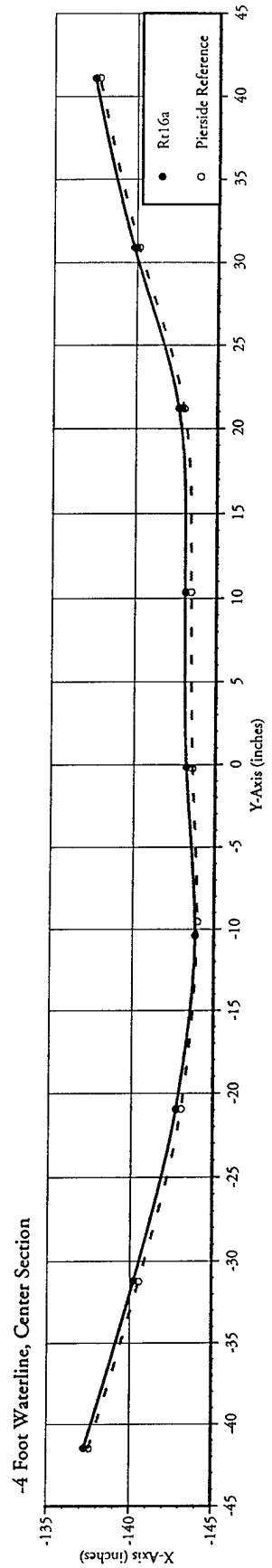
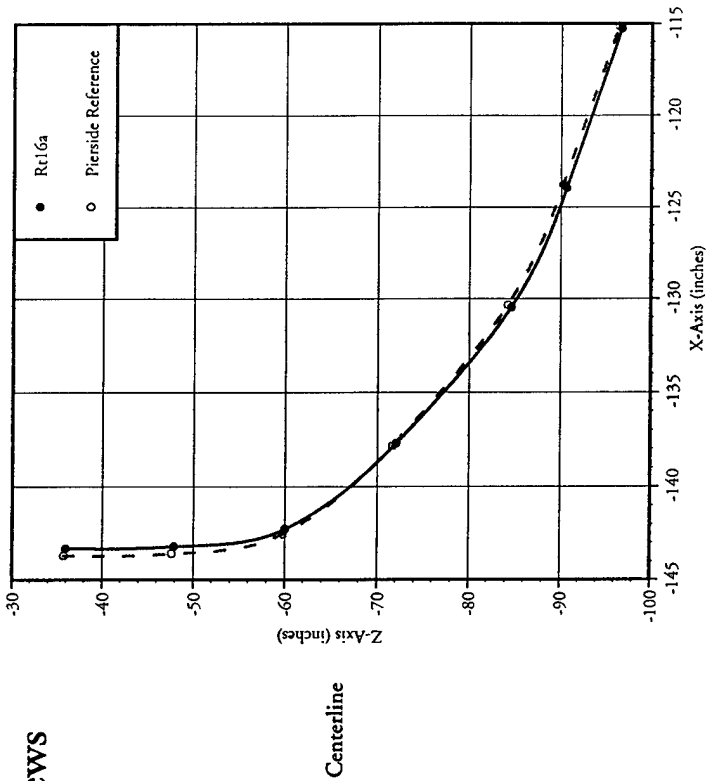

# Static Deflection Cross Sectional Views

## Data Run: CAL15

Speed: 15.9 Kts  
Sea State: 2

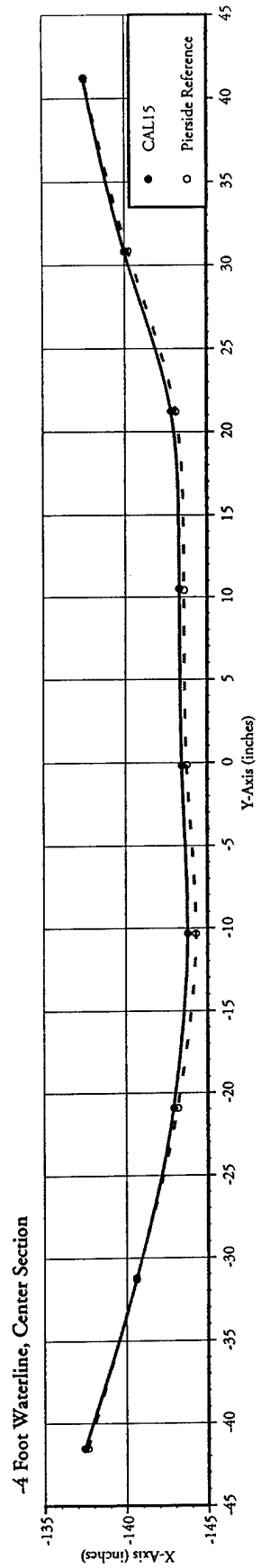
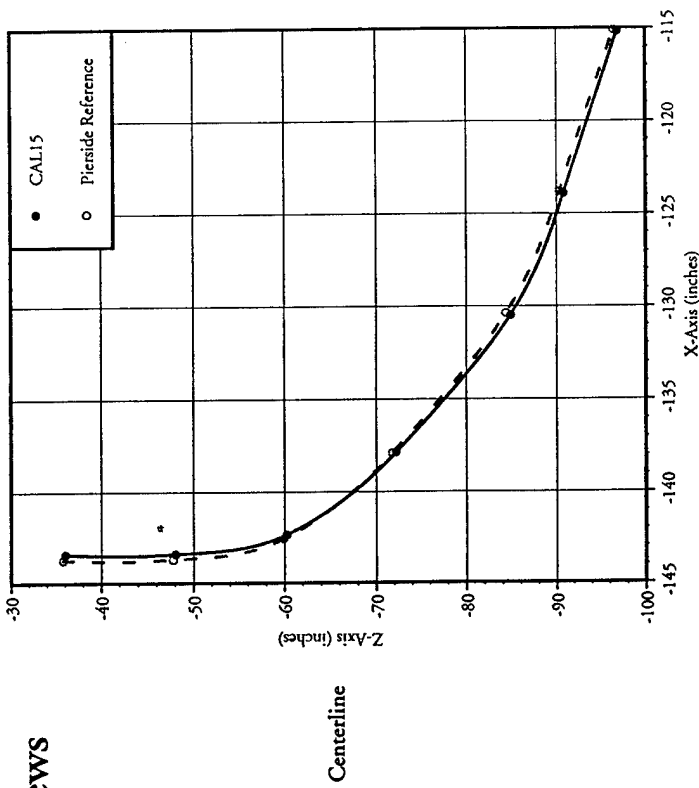

# Static Deflection Cross Sectional Views

**Data Run: RL17a**

Speed: 16.9 Kts

Sea State: 2

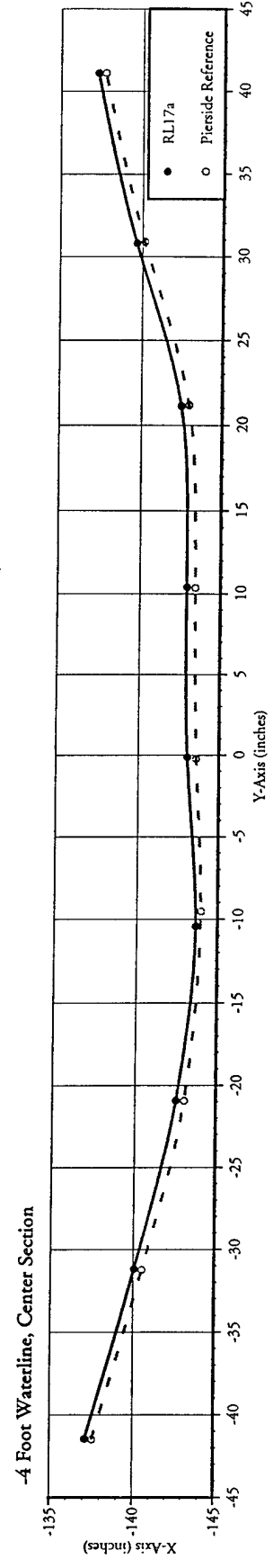
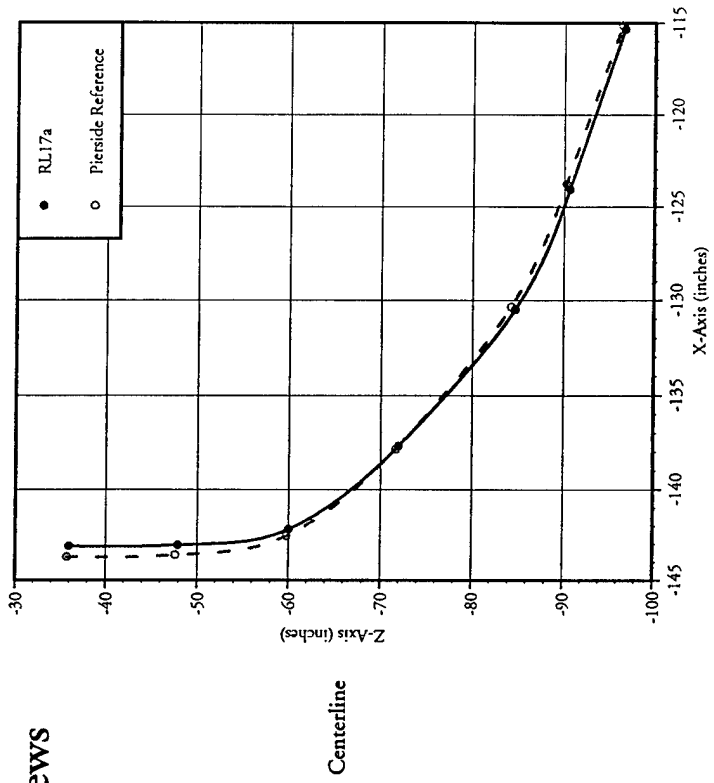

# Static Deflection Cross Sectional Views

## Data Run: Rq18a

Speed: 18.9 Kts

Sea State: 3

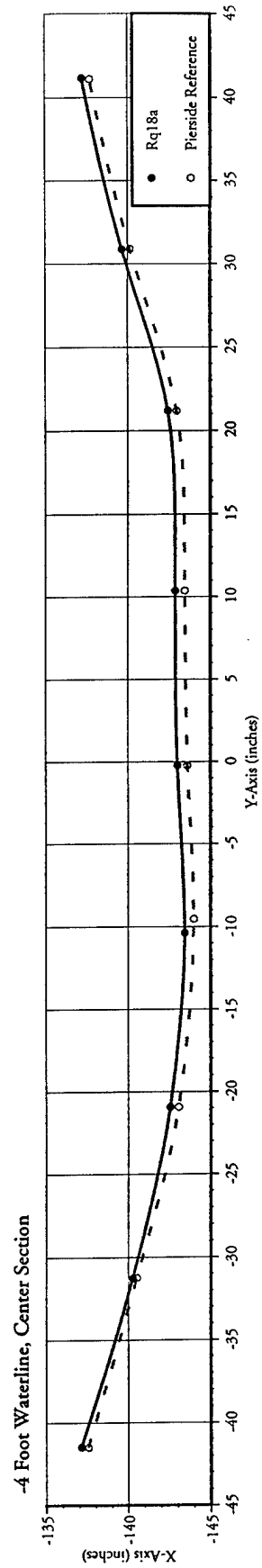
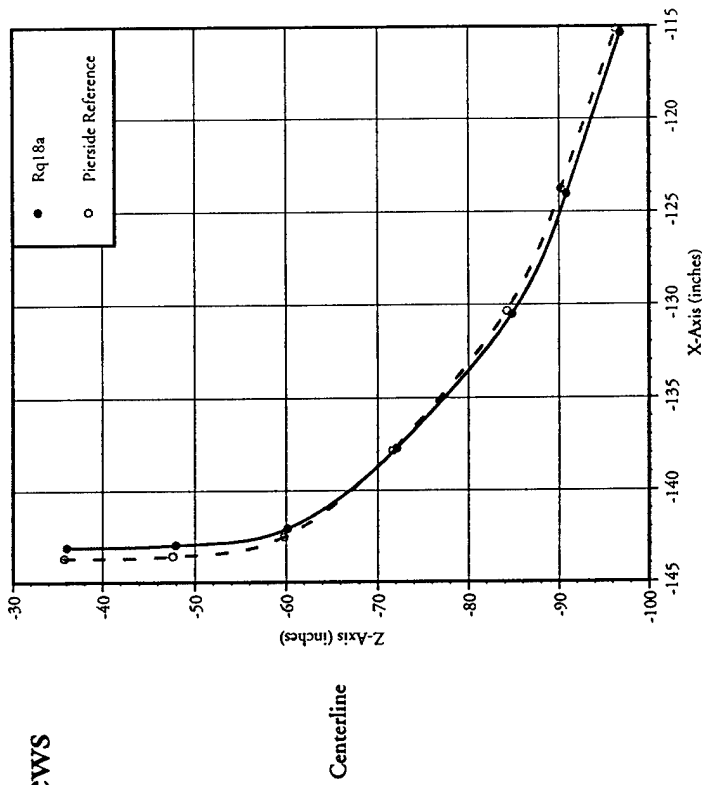

# Static Deflection Cross Sectional Views

## Data Run: Rq18b

Speed: 19.0 Kts  
Sea State: 3

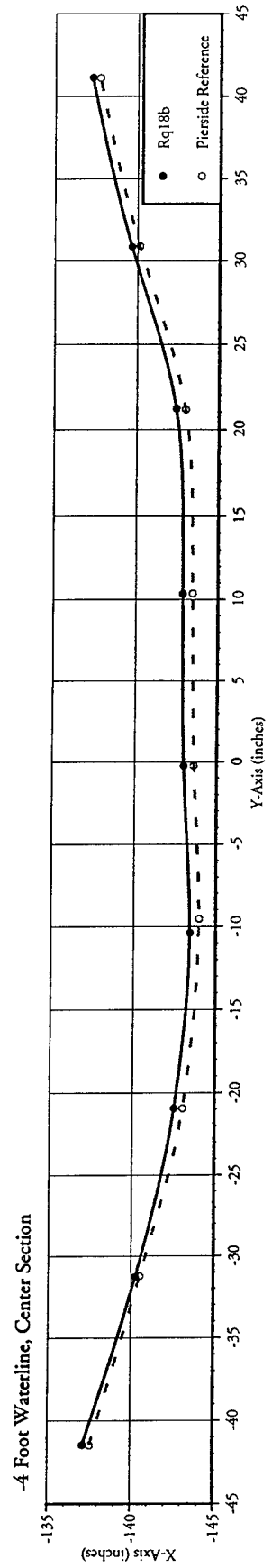
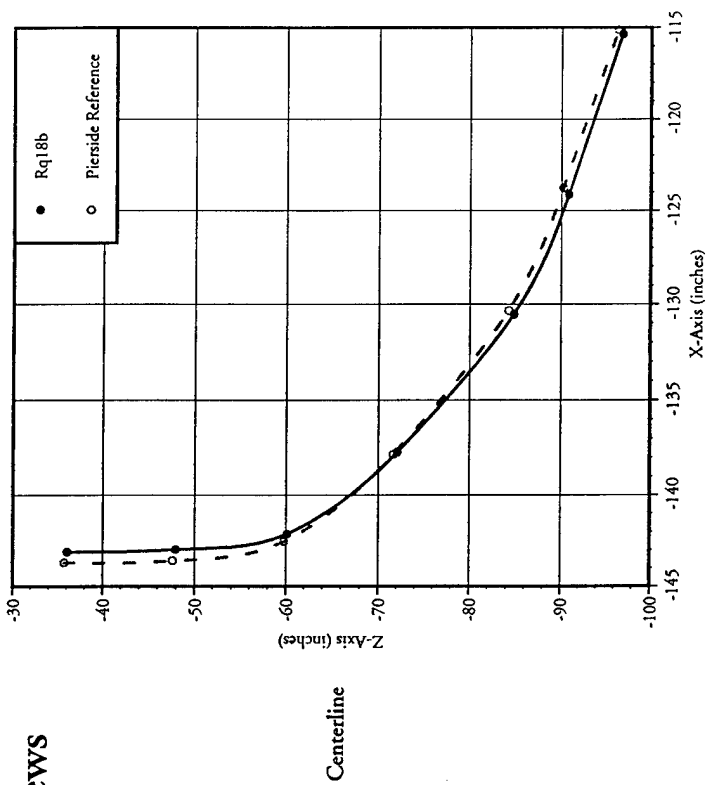

# Static Deflection Cross Sectional Views

## Data Run: Rq19a

Speed: 19.1 Kts

Sea State: 3

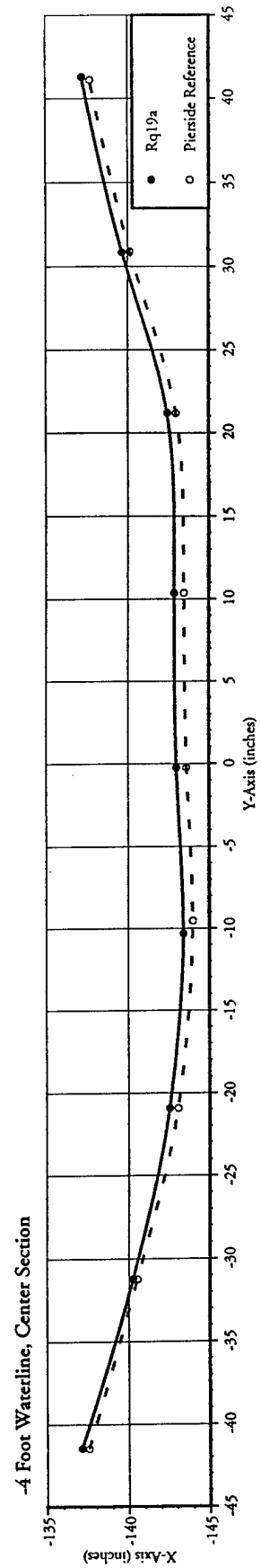
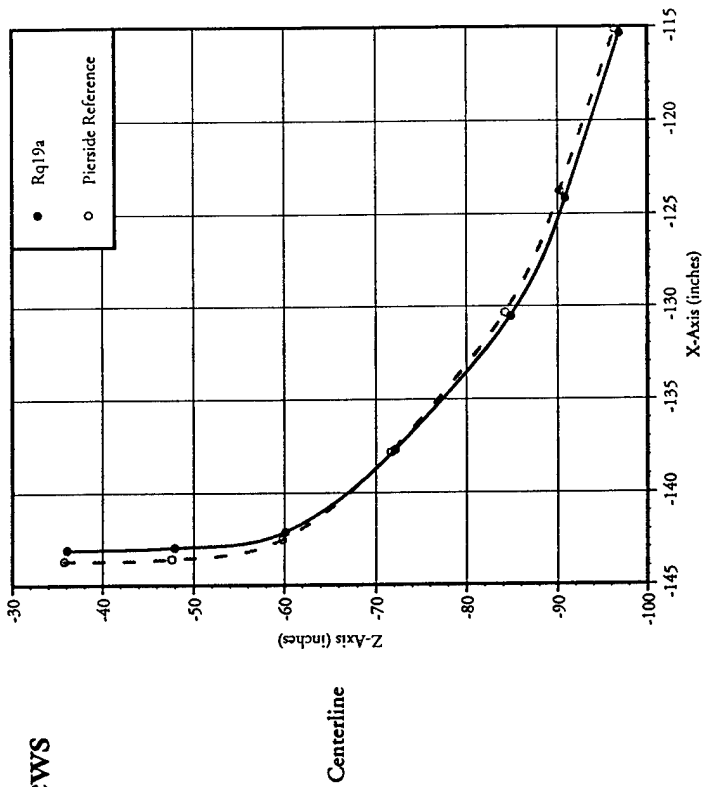

# Static Deflection Cross Sectional Views

## Data Run: CAL19

Speed: 19.4 Kts  
Sea State: 2

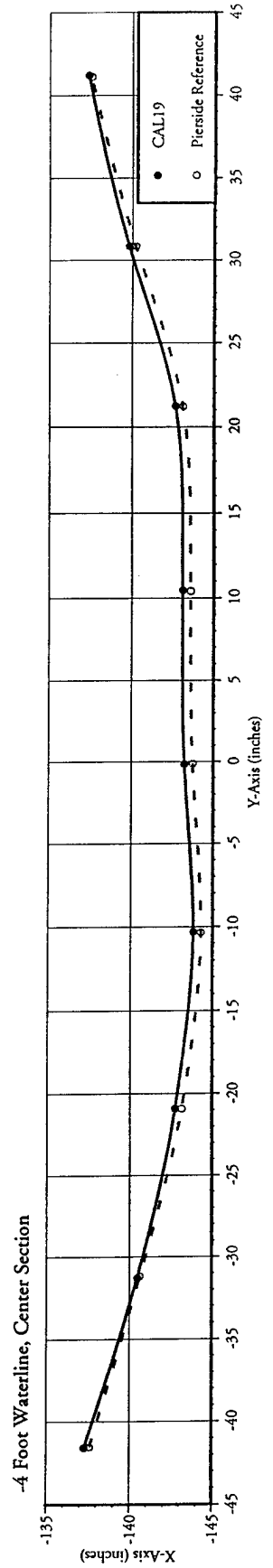
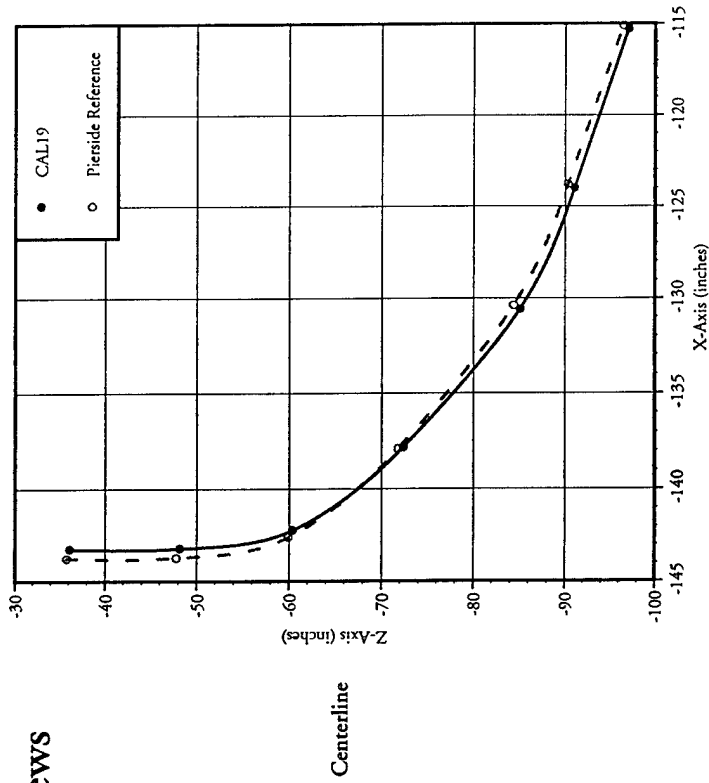

# Static Deflection Cross Sectional Views

Data Run: RC20a

Speed: 20.2 Kts

Sea State: 2

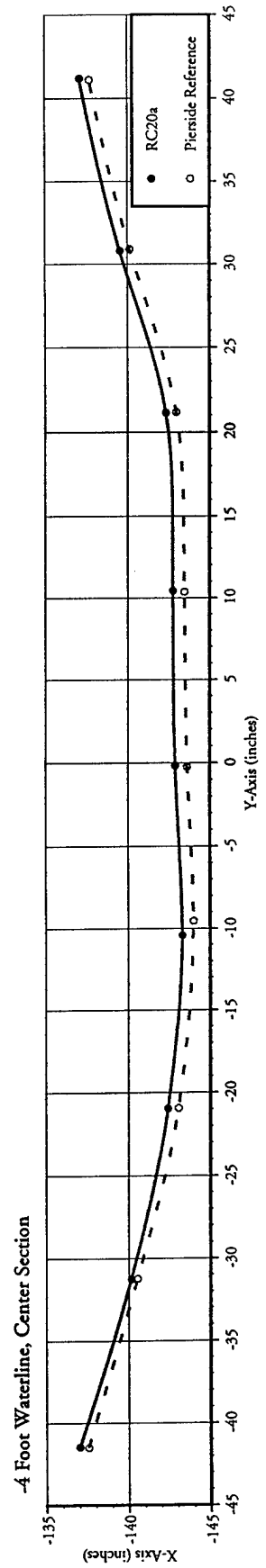
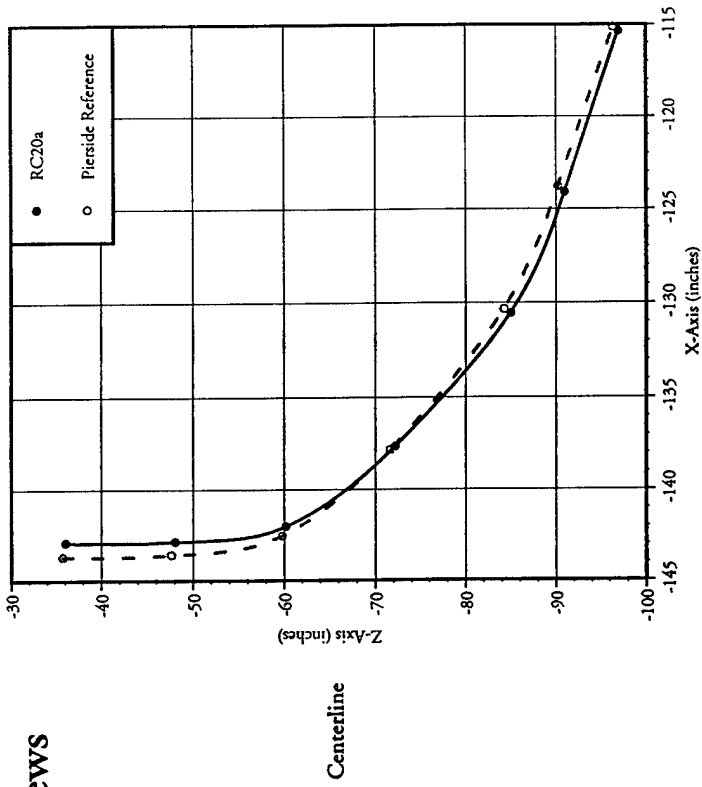



# Static Deflection Cross Sectional Views

## Data Run: RC20b

Speed: 20.3 Kts  
Sea State: 2

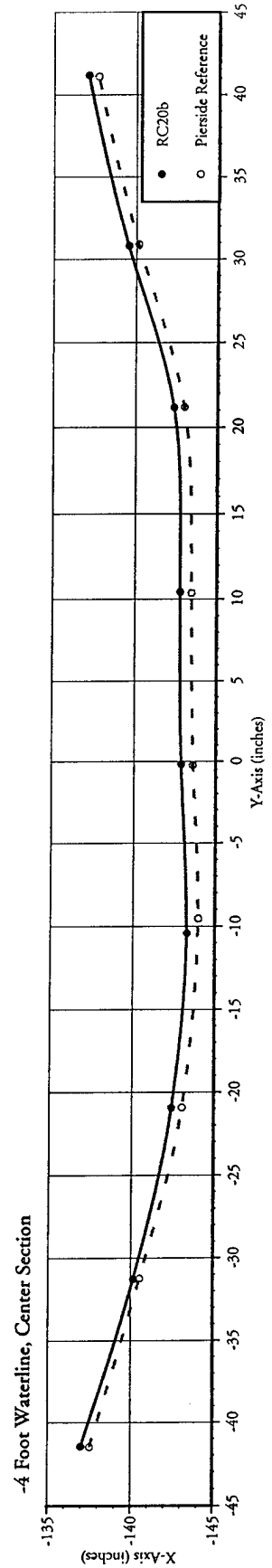
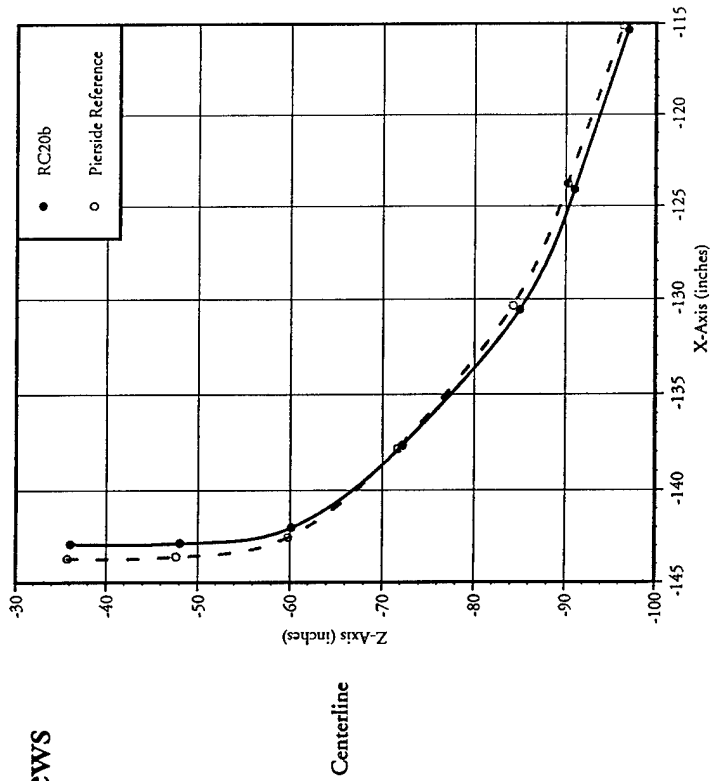

# Static Deflection Cross Sectional Views

## Data Run: CAL20

Speed: 20.4 Kts  
Sea State: 3

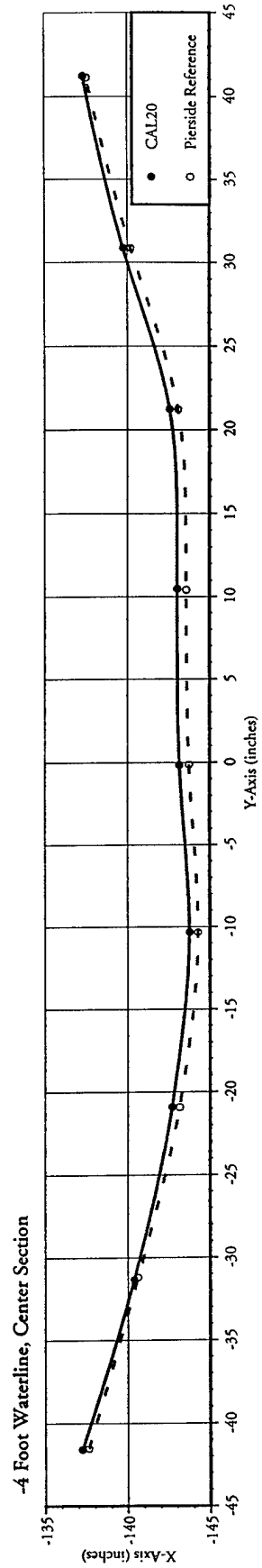
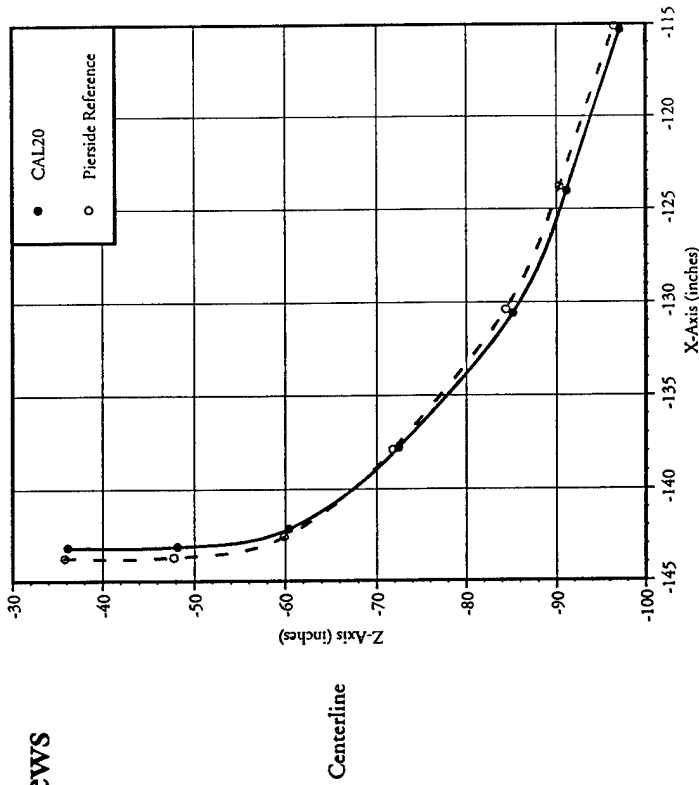

# Static Deflection Cross Sectional Views

## Data Run: Rp20b

Speed: 20.7 Kts  
Sea State = 3

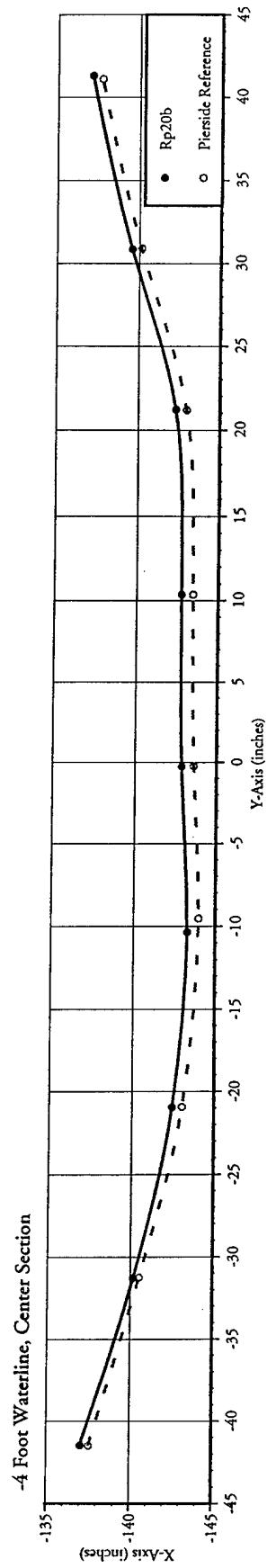
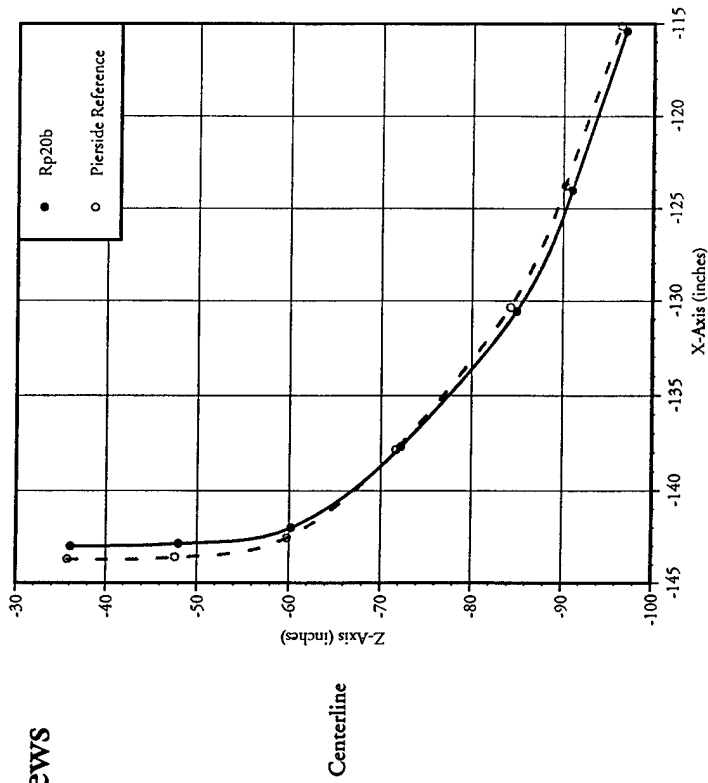

# Static Deflection Cross Sectional Views

## Data Run: Rp20a

Speed: 20.8 Kts

Sea State: 3

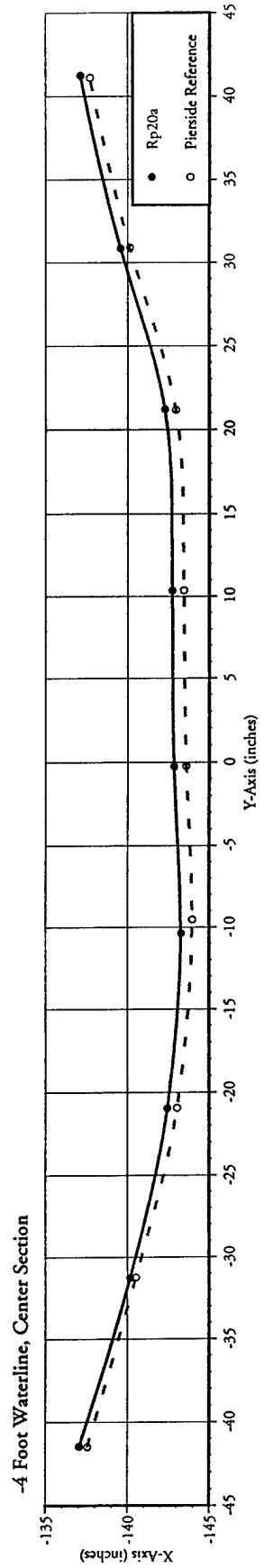
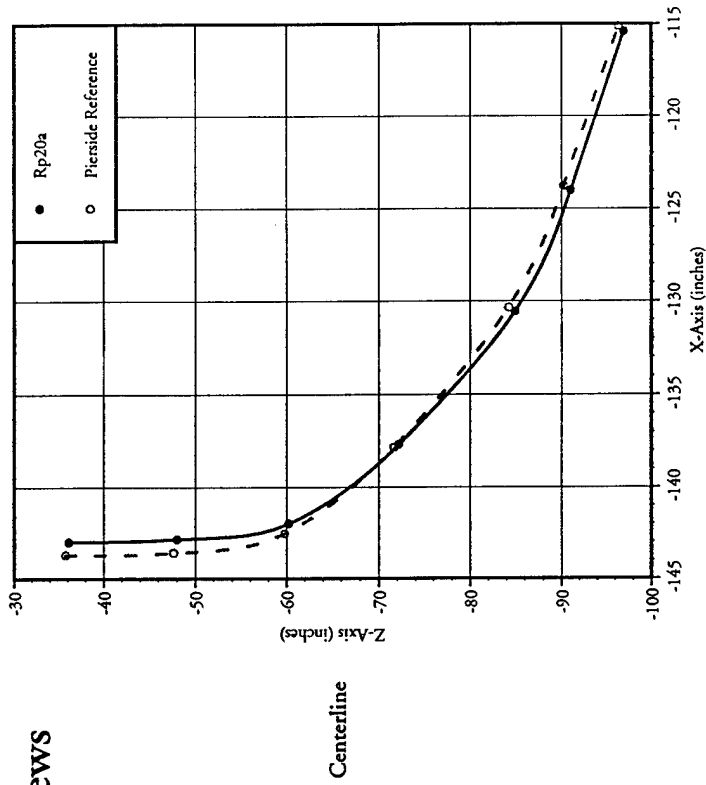

# Static Deflection Cross Sectional Views

## Data Run: RAD31H

Speed: 21 Kts  
Sea State: 2

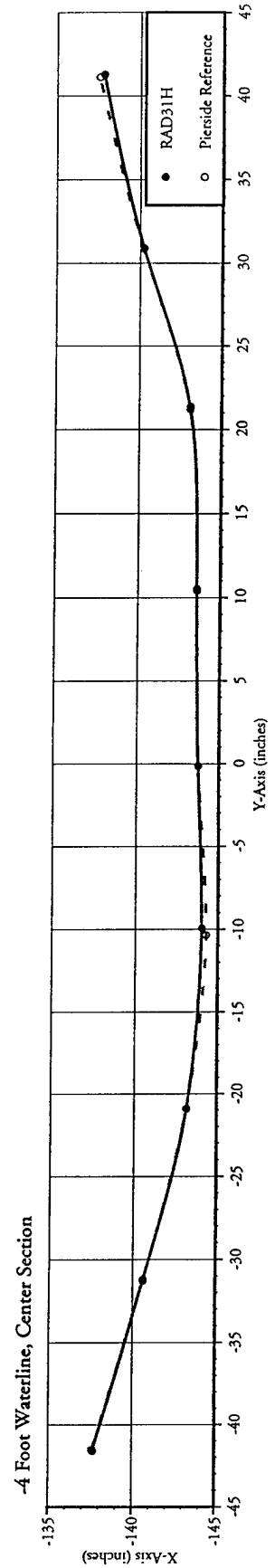
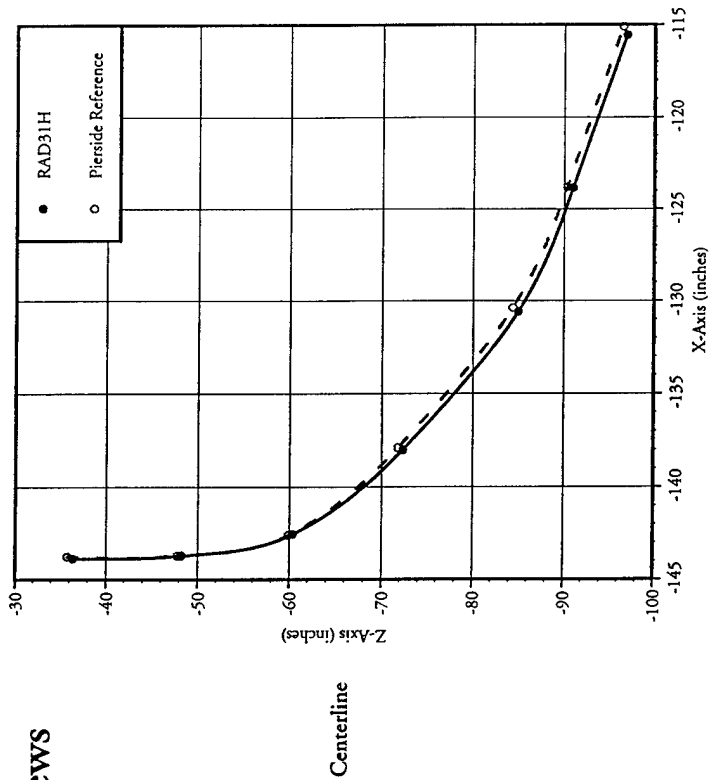

# Static Deflection Cross Sectional Views

## Data Run: RL21a

Speed: 21.1 Kts  
Sea State = 2

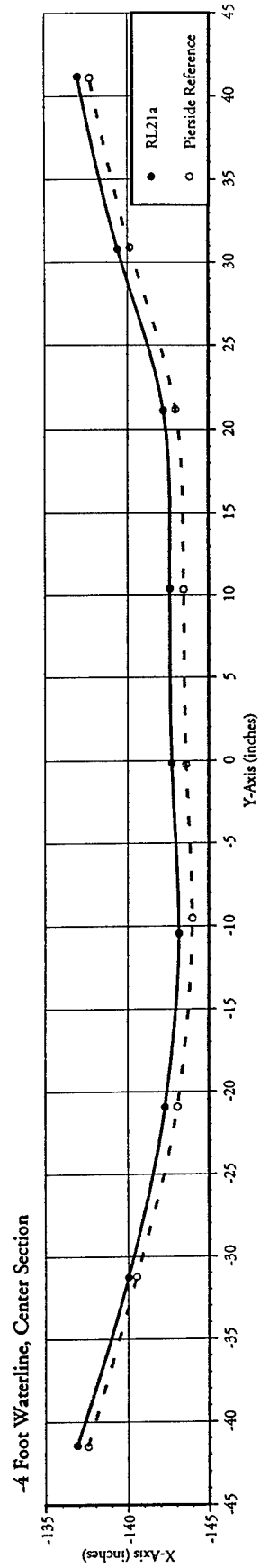
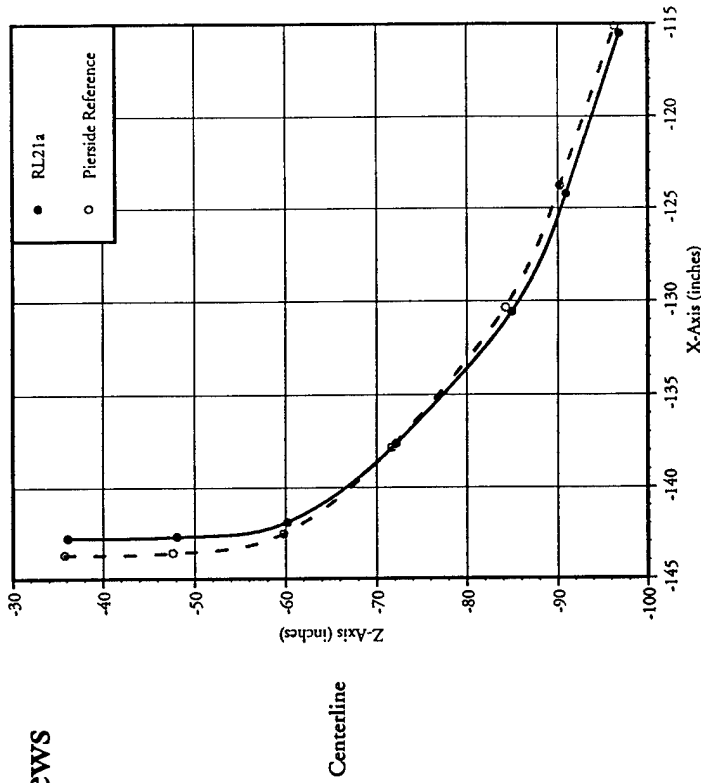

Static Deflection Cross Sectional Views  
 Data Run: RL21c  
 Speed: 21.1 Kts  
 Sea State: 2

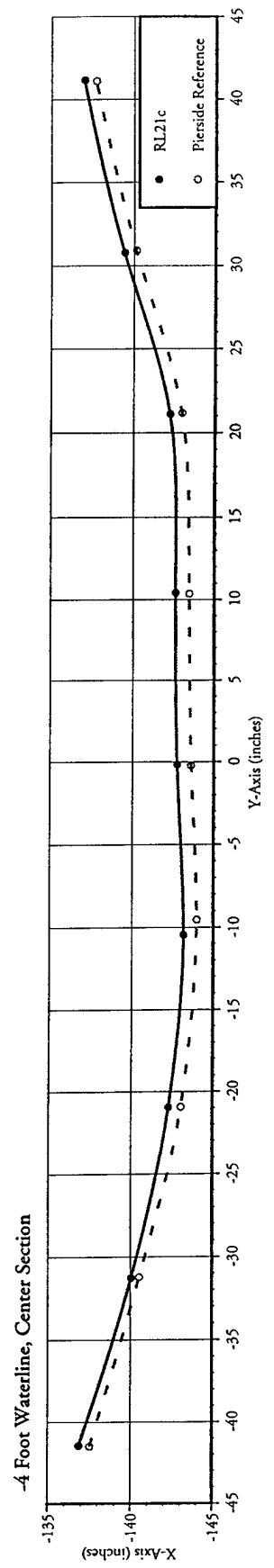
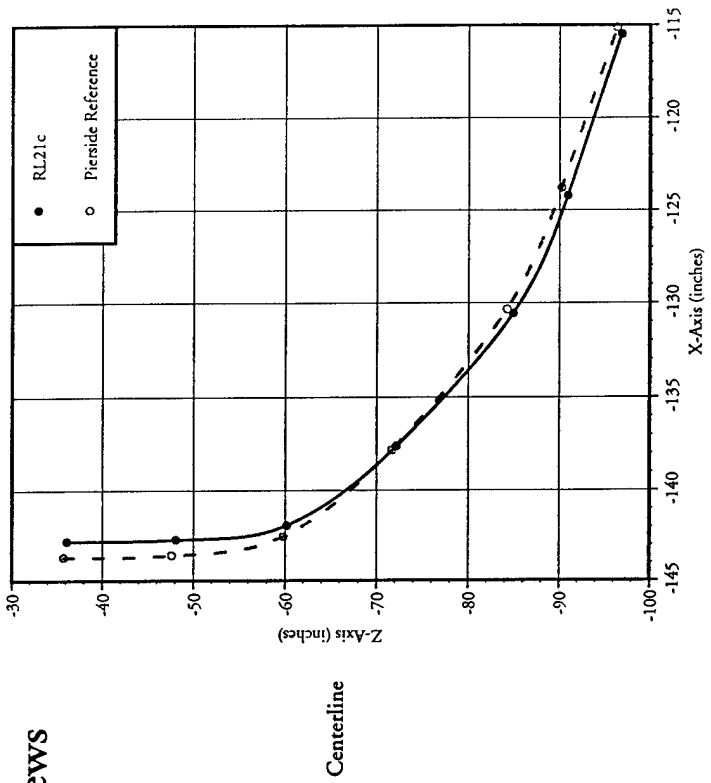

# Static Deflection Cross Sectional Views

## Data Run: RL21b

Speed: 21.2 Kts  
Sea State: 2

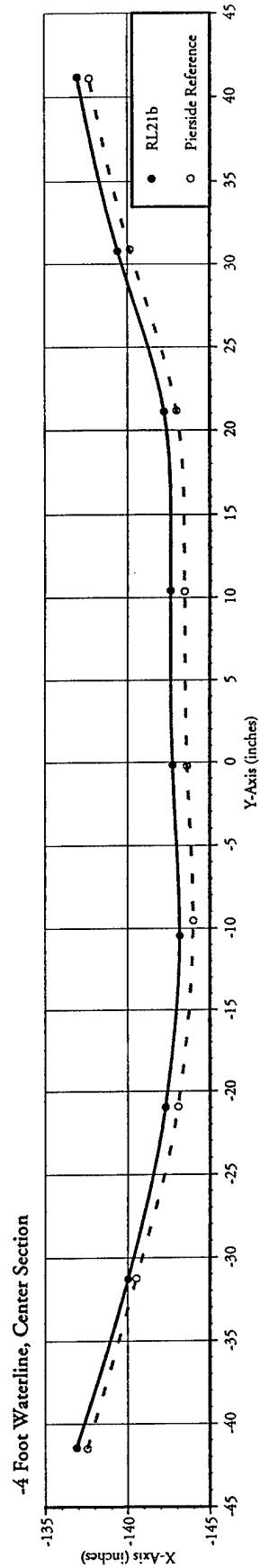
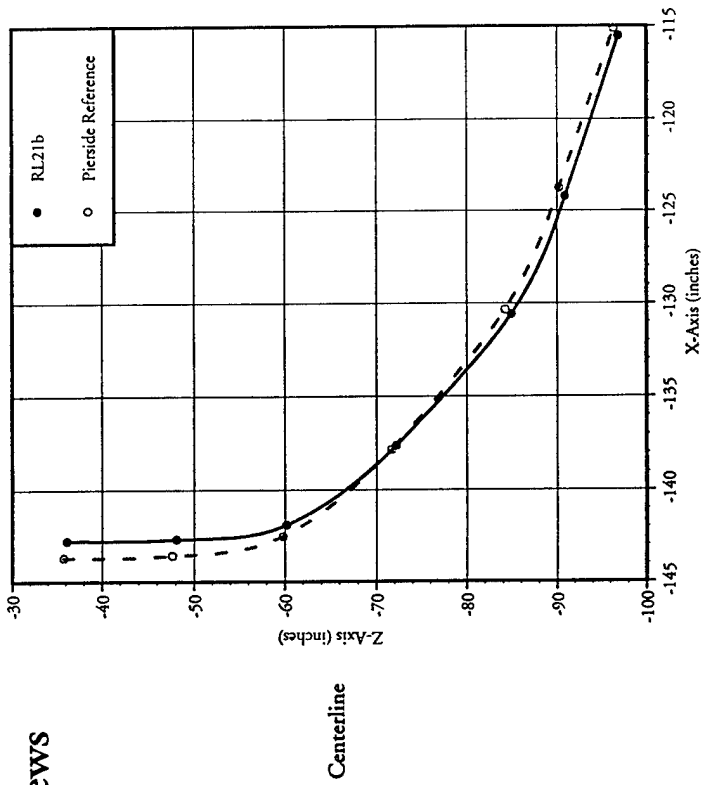



# Static Deflection Cross Sectional Views

## Data Run: RL21d

Speed: 21.2 Kts  
Sea State: 2

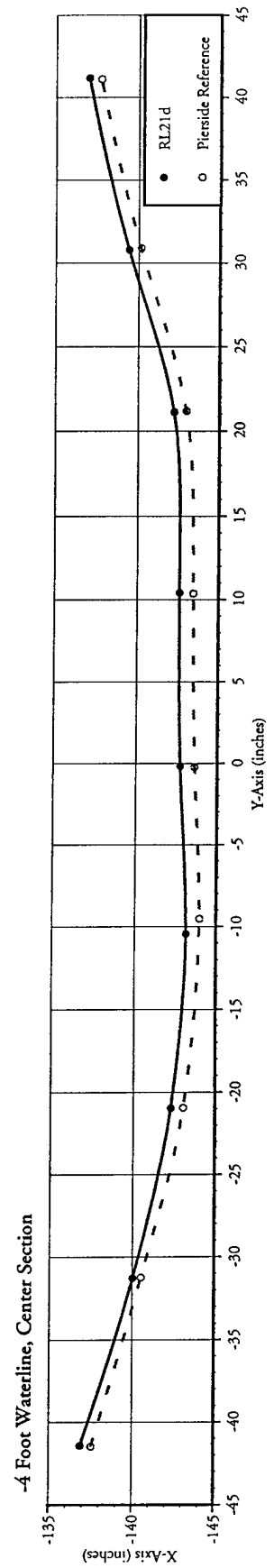
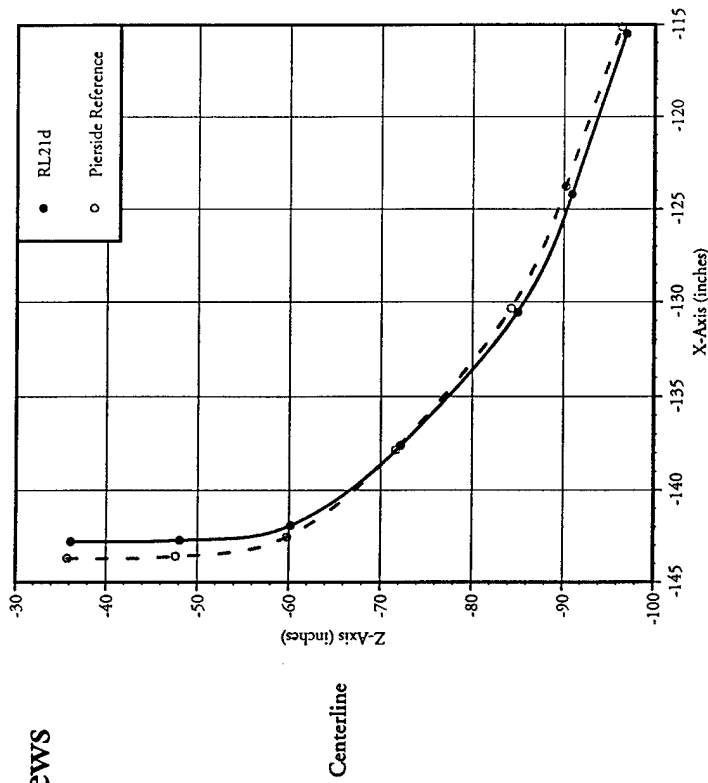

# Static Deflection Cross Sectional Views

Data Run: RLM28a

Speed: 22 Kts

Sea State: 2

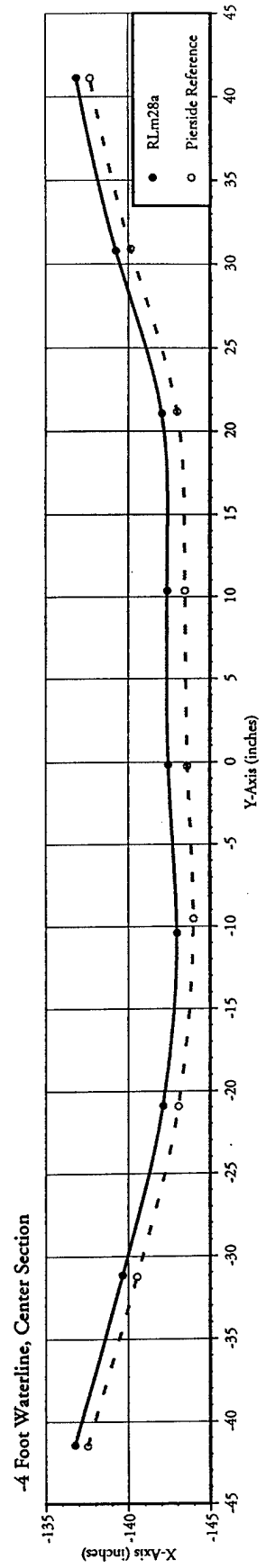
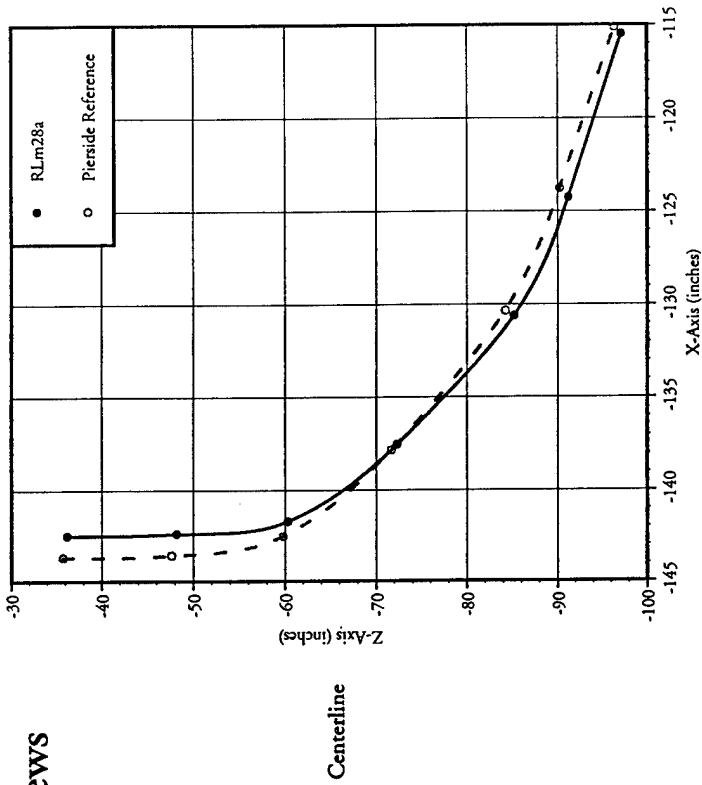

# Static Deflection Cross Sectional Views

## Data Run: Rp21a

Speed: 23.2 Kts  
Sea State: 3

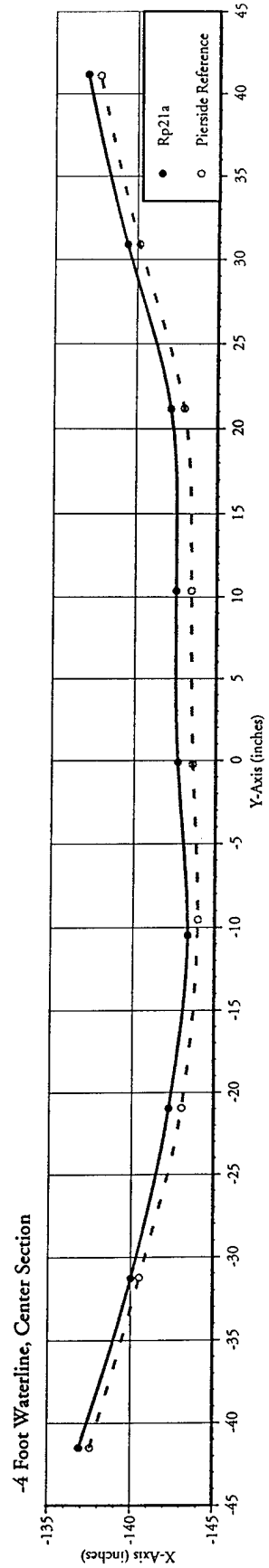
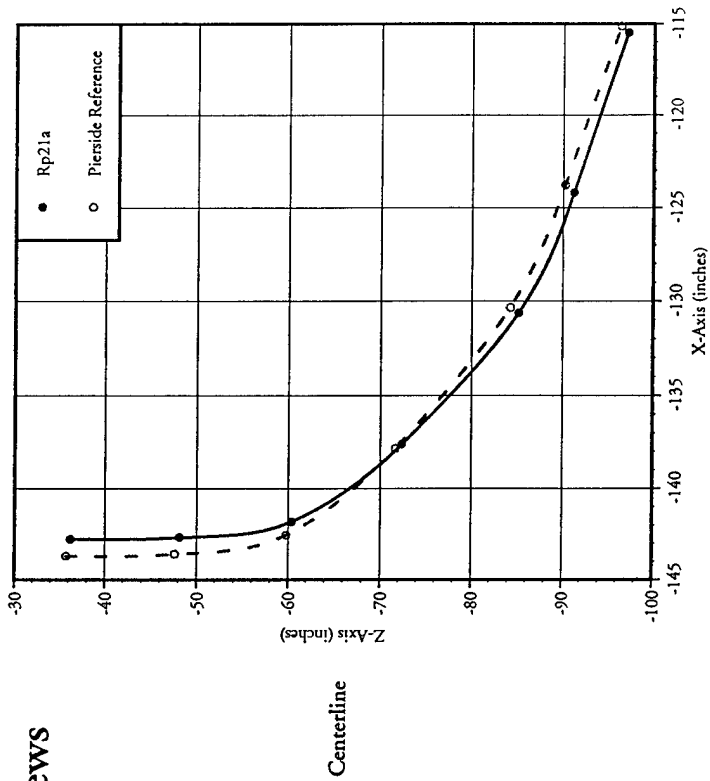

# Static Deflection Cross Sectional Views

## Data Run: RL23a

Speed: 23.4 Kts  
Sea State: 2

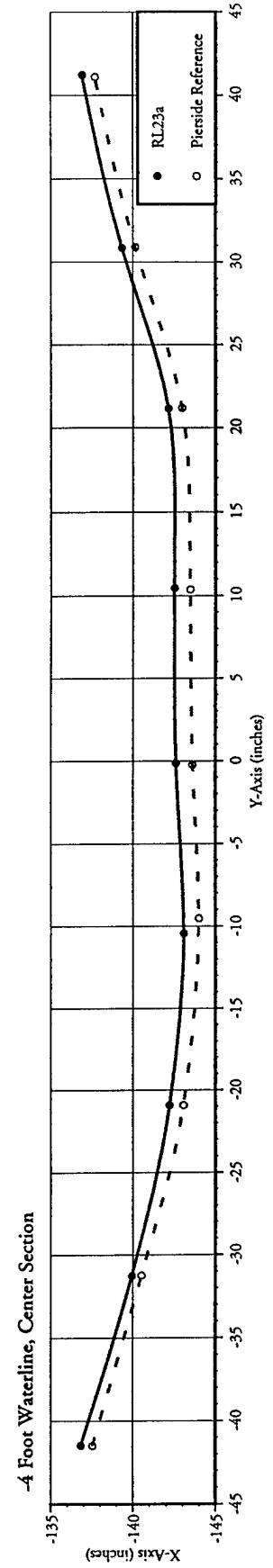
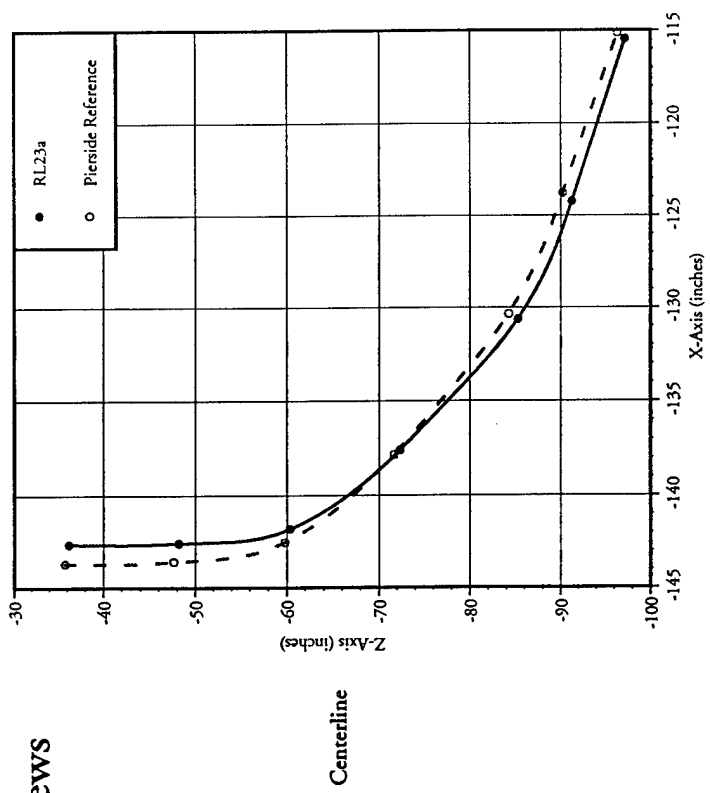

# Static Deflection Cross Sectional Views

## Data Run: RL23b

Speed: 23.4 Kts  
Sea State: 2

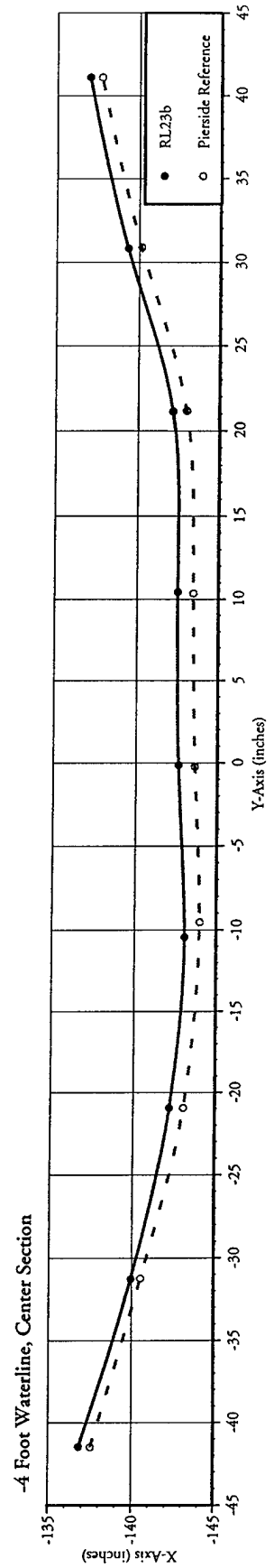
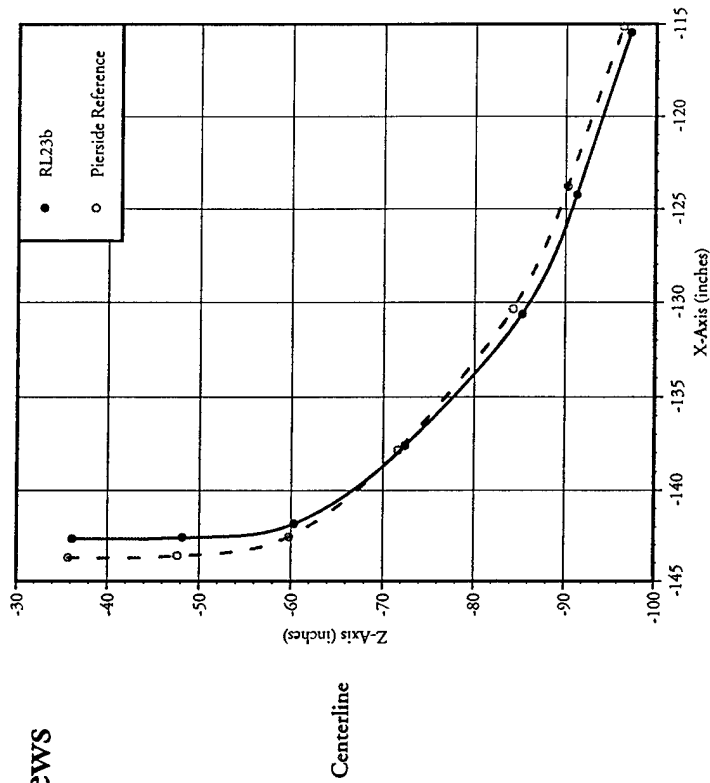

# Static Deflection Cross Sectional Views

Data Run: R24a

Speed: 24 Kts

Sea State: 5

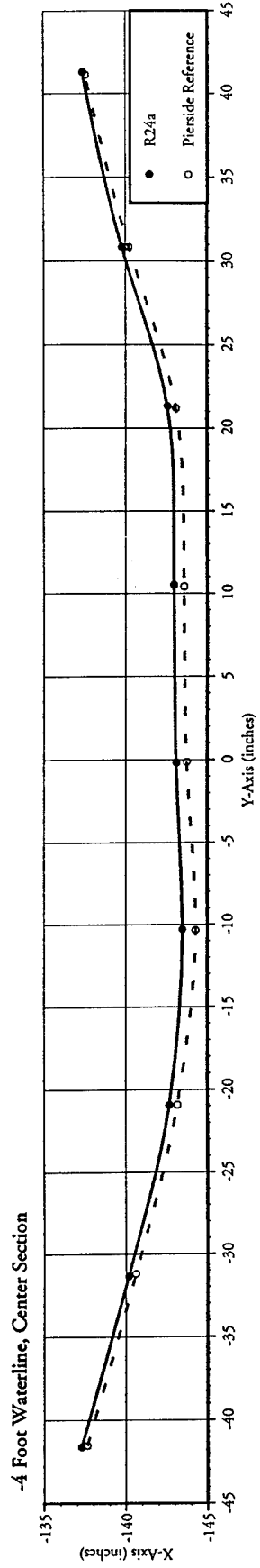
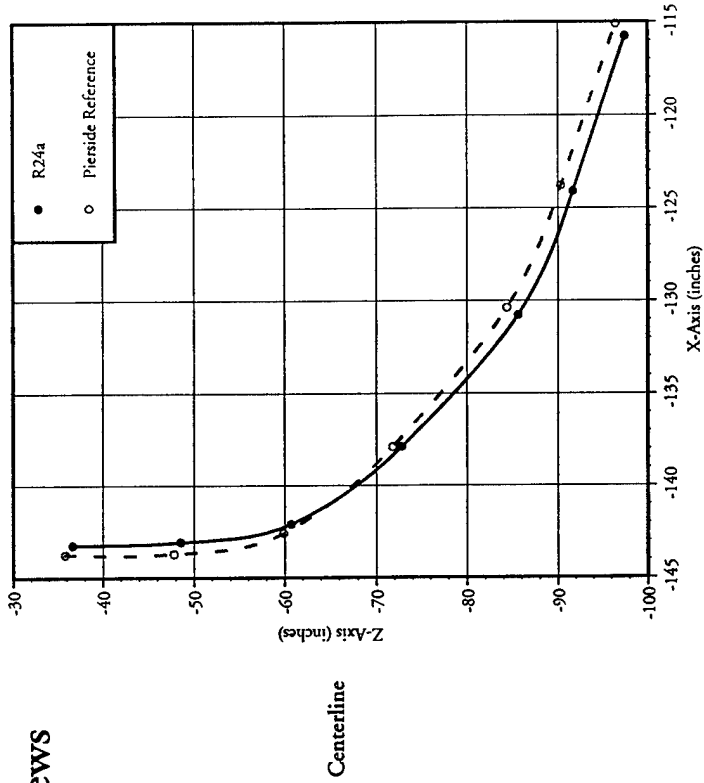

# Static Deflection Cross Sectional Views

## Data Run: RL25a

Speed: 25.4 Kts  
Sea State: 2

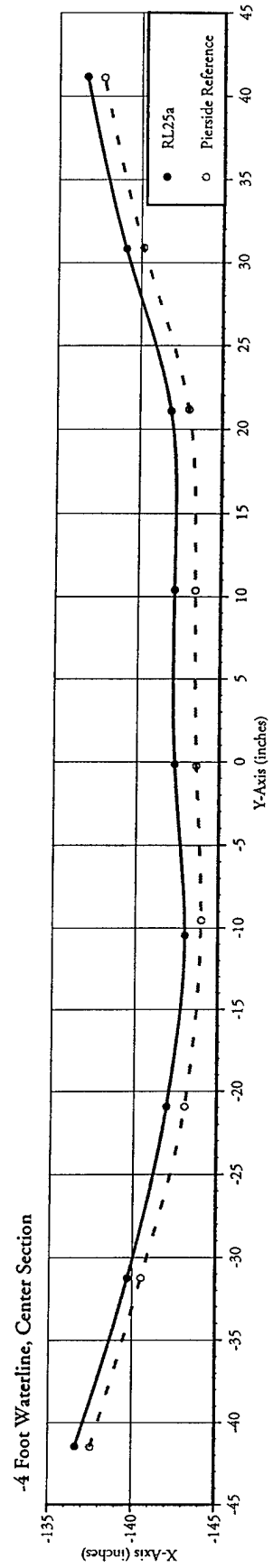
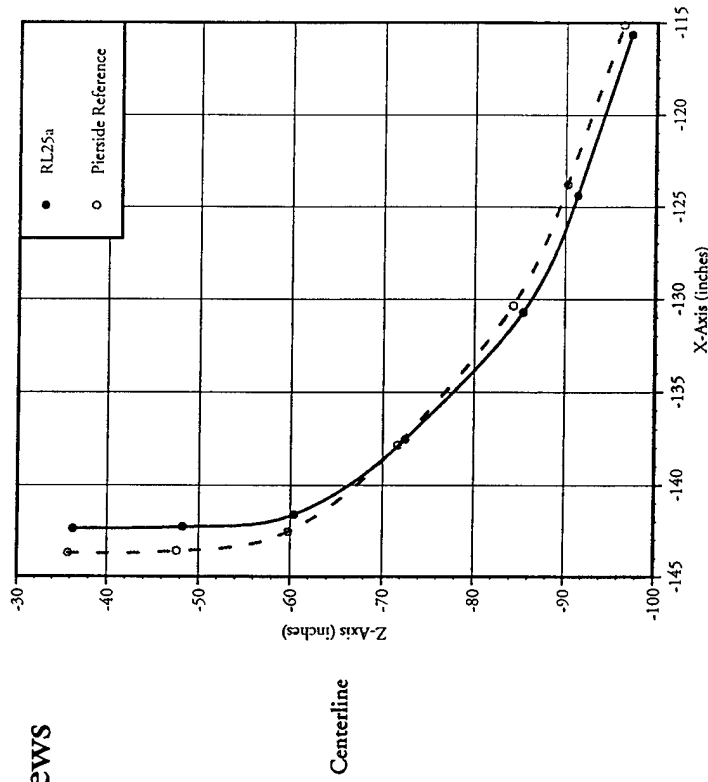

# Static Deflection Cross Sectional Views

## Data Run: RL26a

Speed: 25.7 Kts  
Sea State: 2

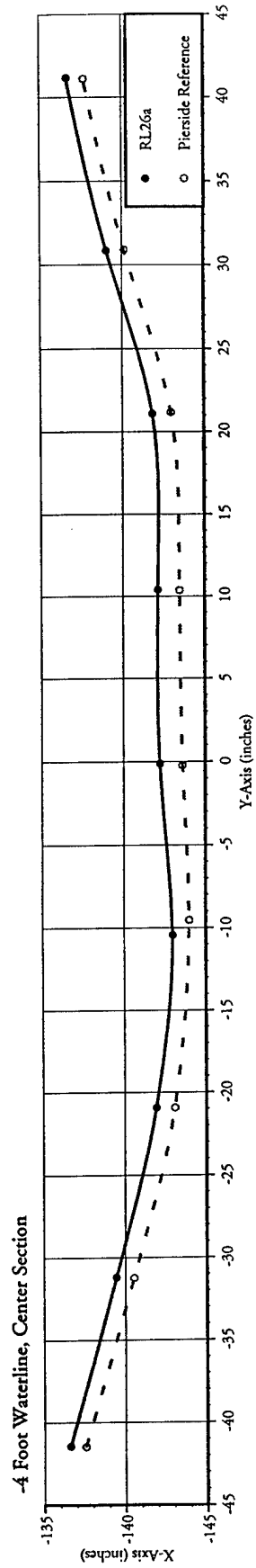
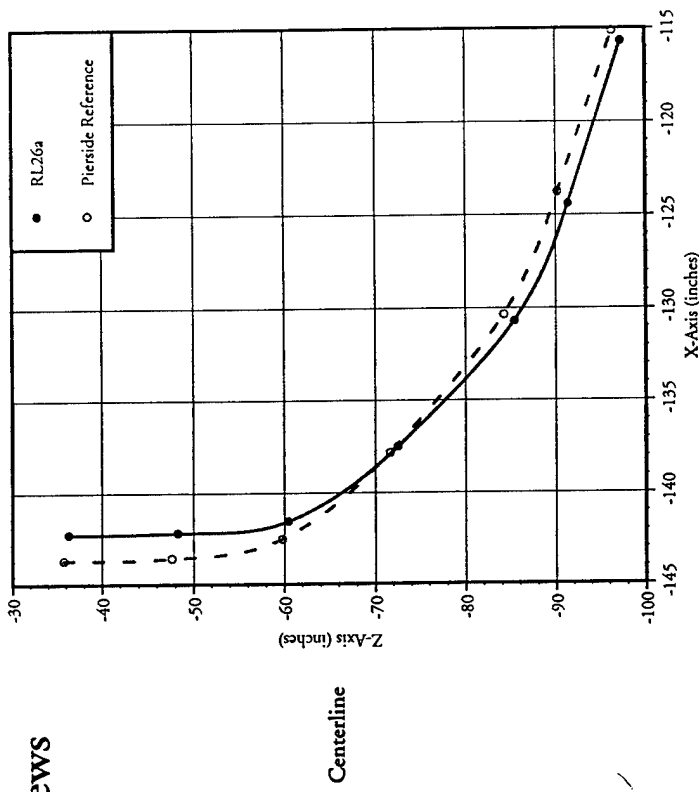



# Static Deflection Cross Sectional Views

## Data Run: RL26b

Speed: 25.7 Kts  
Sea State: 2

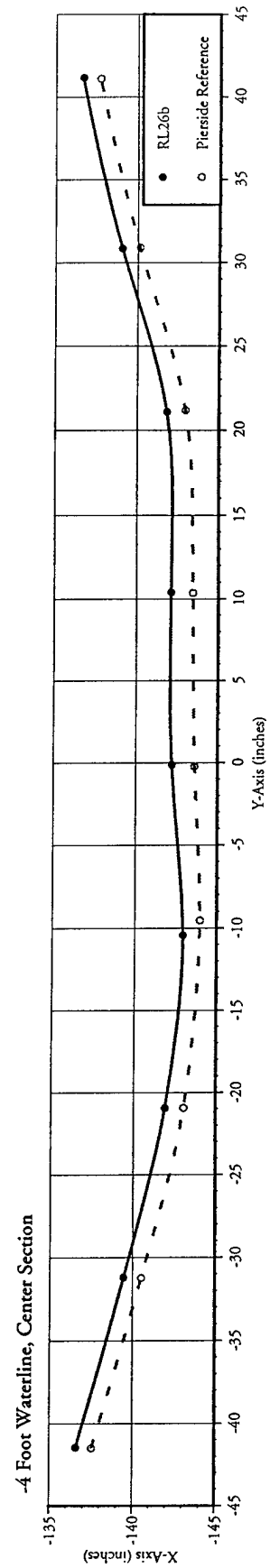
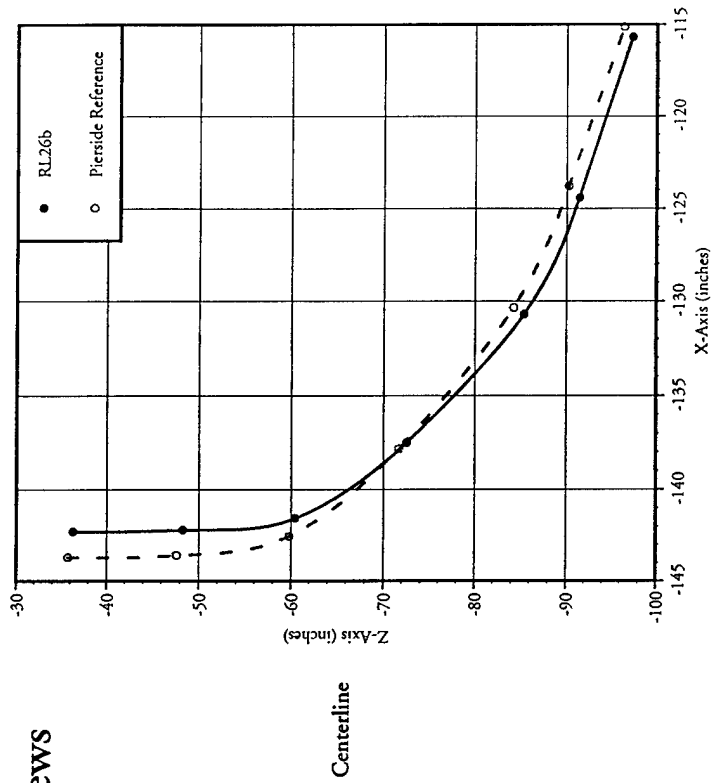

# Static Deflection Cross Sectional Views

## Data Run: R27A

Speed: 27 Kts  
Sea State: 3

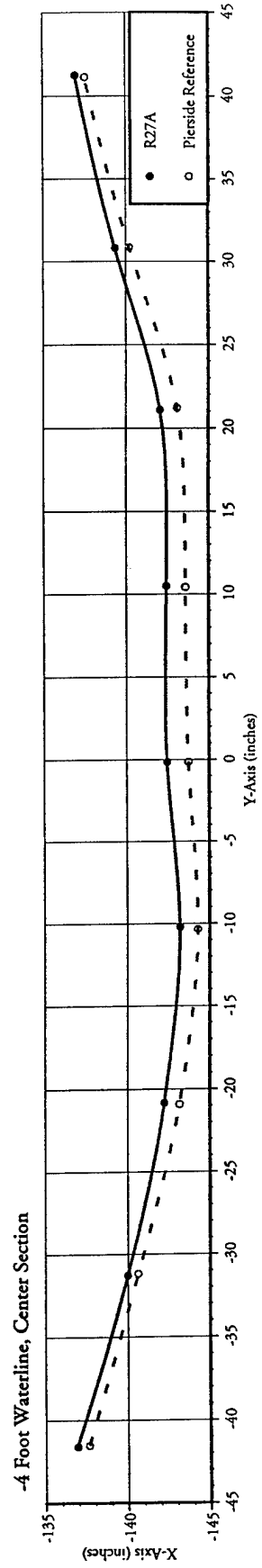
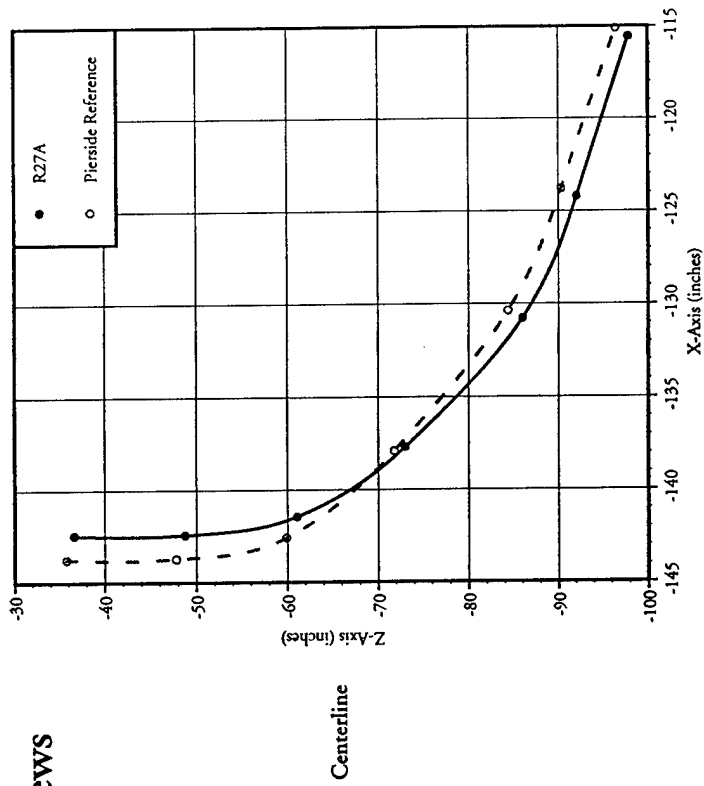

# Static Deflection Cross Sectional Views

## Data Run: Rq26a

Speed: 27.4 Kts  
Sea State: 3

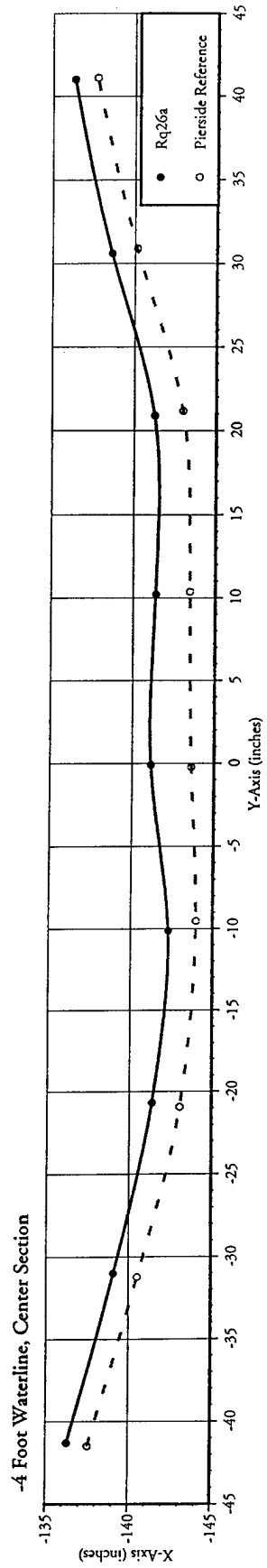
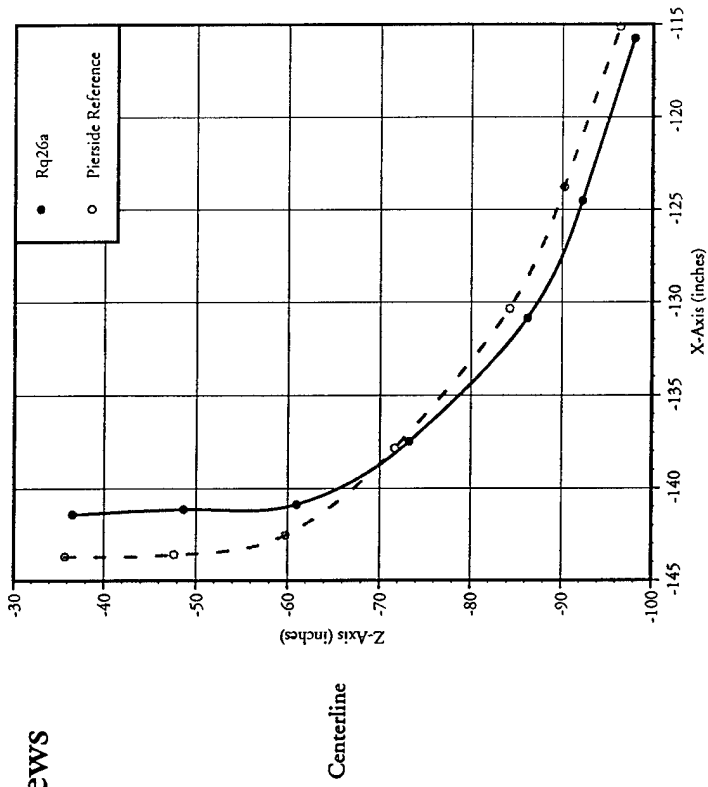

# Static Deflection Cross Sectional Views

Data Run: Rq27a

Speed: 27.7 Kts

Sea State = 2

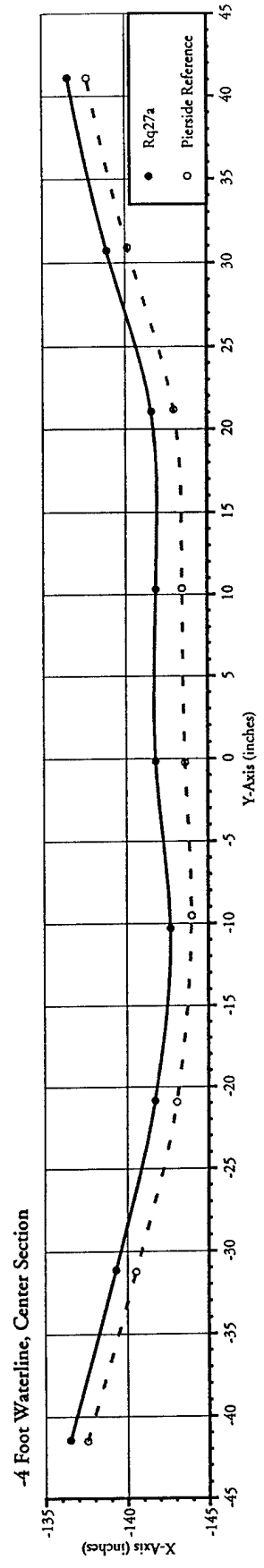
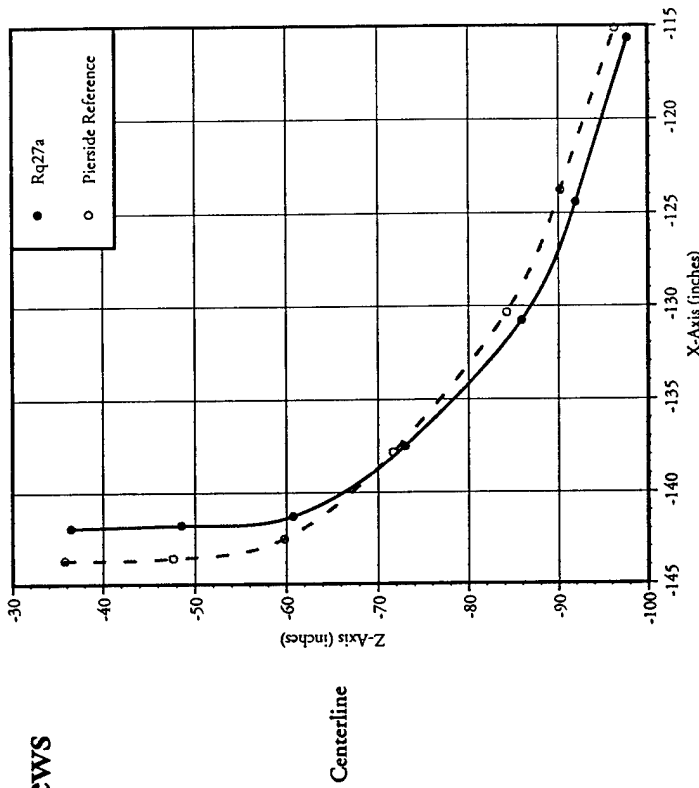

# Static Deflection Cross Sectional Views

## Data Run: RL28a

Speed: 27.9 Kts

Sea State: 2

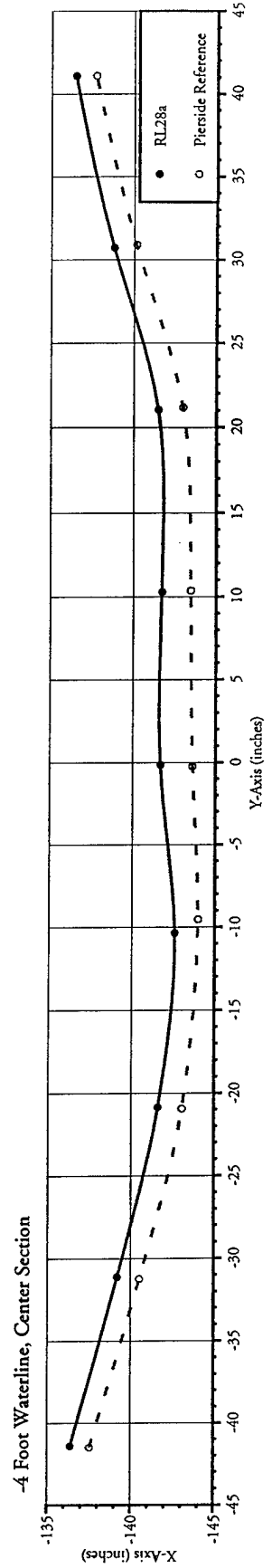
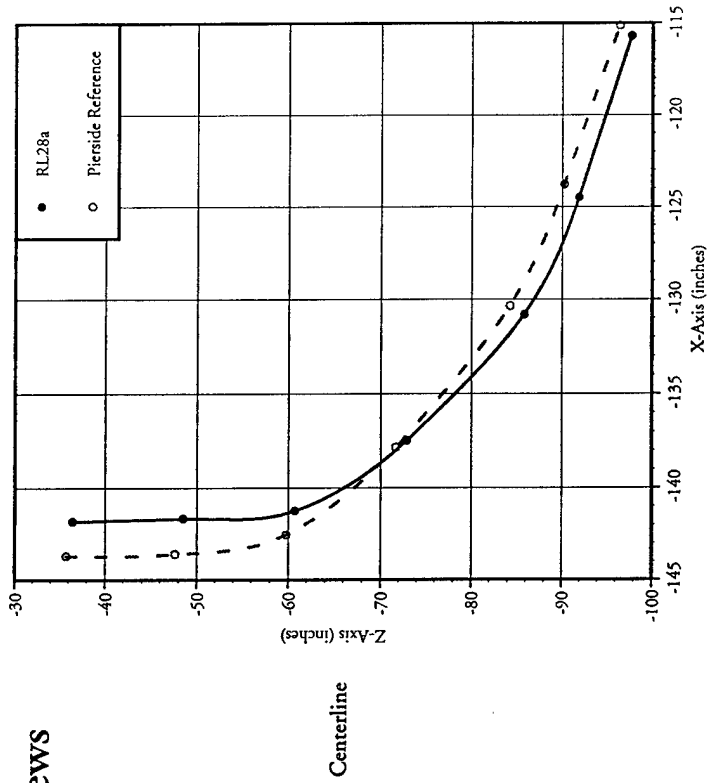

# Static Deflection Cross Sectional Views

Data Run: Rq28a

Speed: 28.5 Kts

Sea State = 2

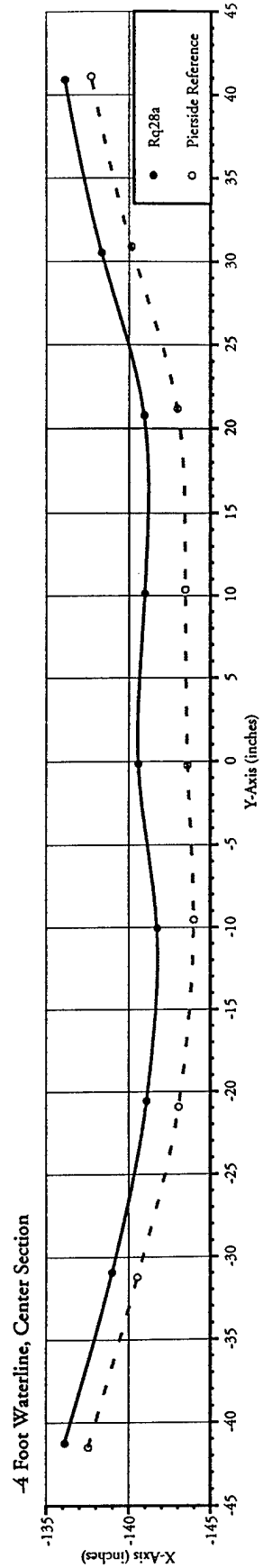
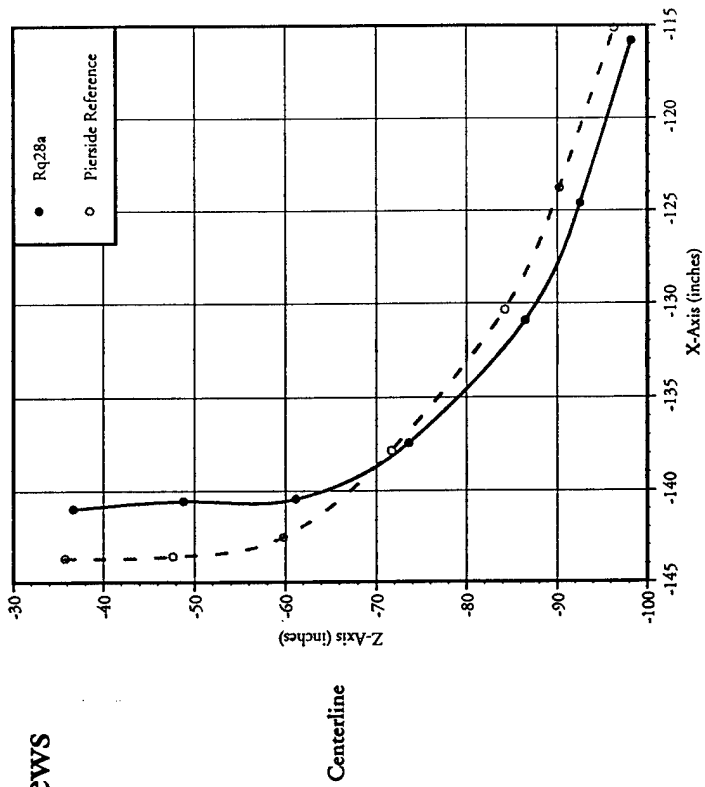

# Static Deflection Cross Sectional Views

## Data Run: Rq28c

Speed: 28.6 Kts

Sea State: 3

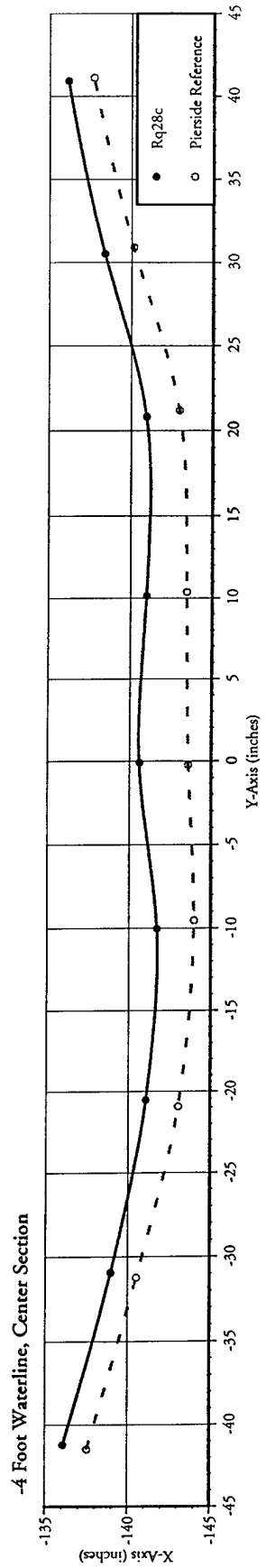
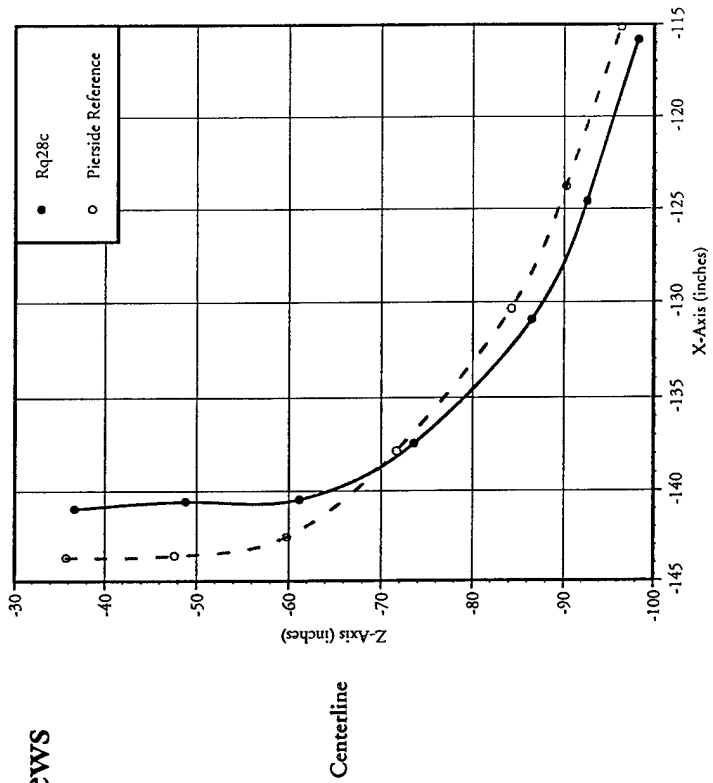

# Static Deflection Cross Sectional Views

Data Run: Rq28b

Speed: 28.7 Kts

Sea State = 2

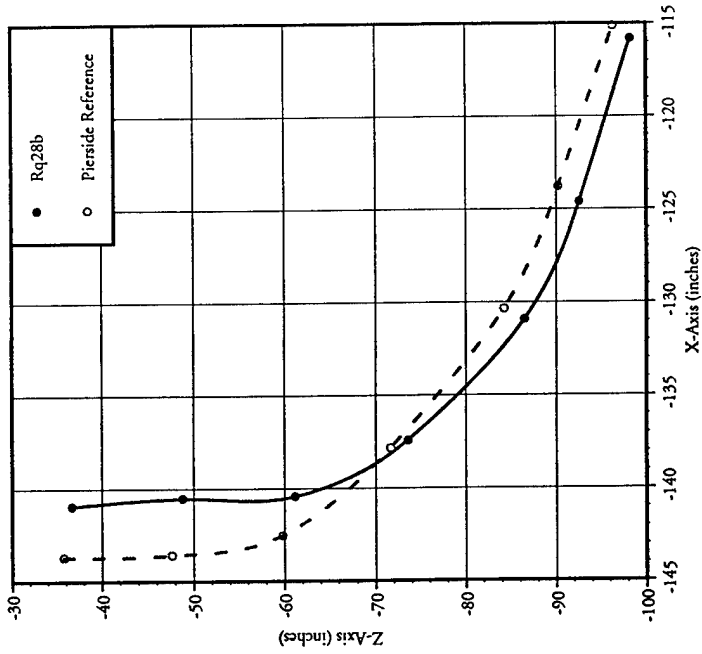

Centerline

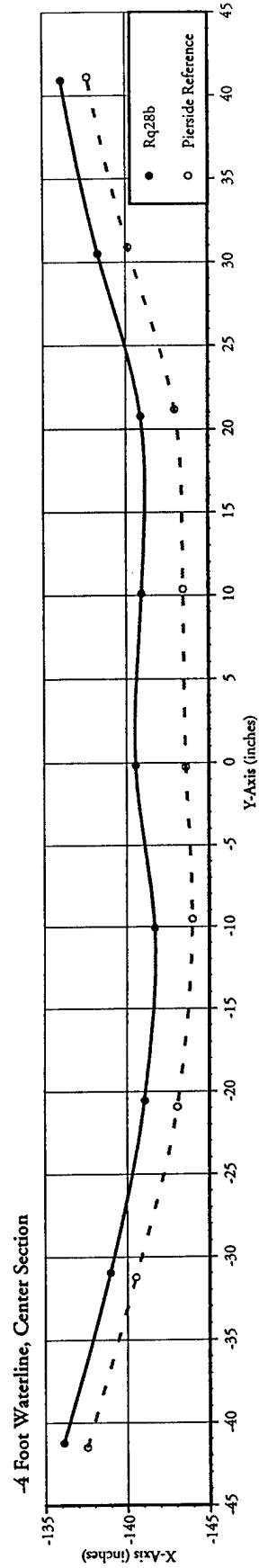

-4 Foot Waterline, Center Section



# Static Deflection Cross Sectional Views

## Data Run: R30A

Speed: 30 Kts  
Sea State: 4

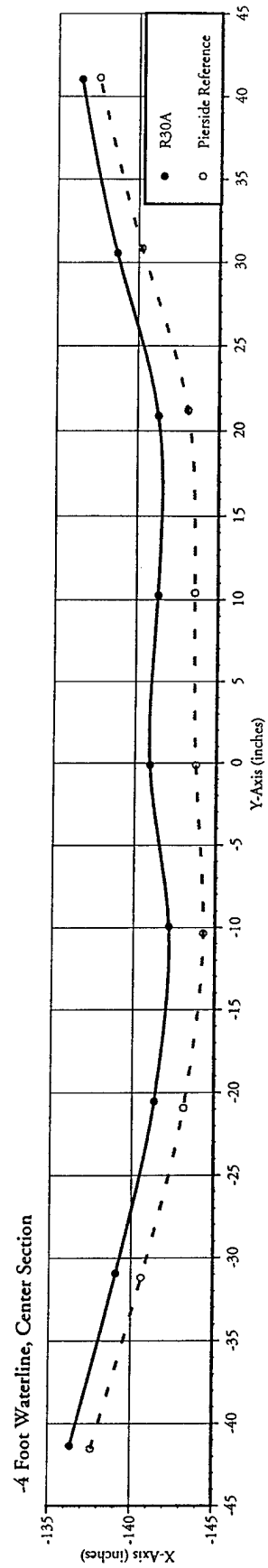
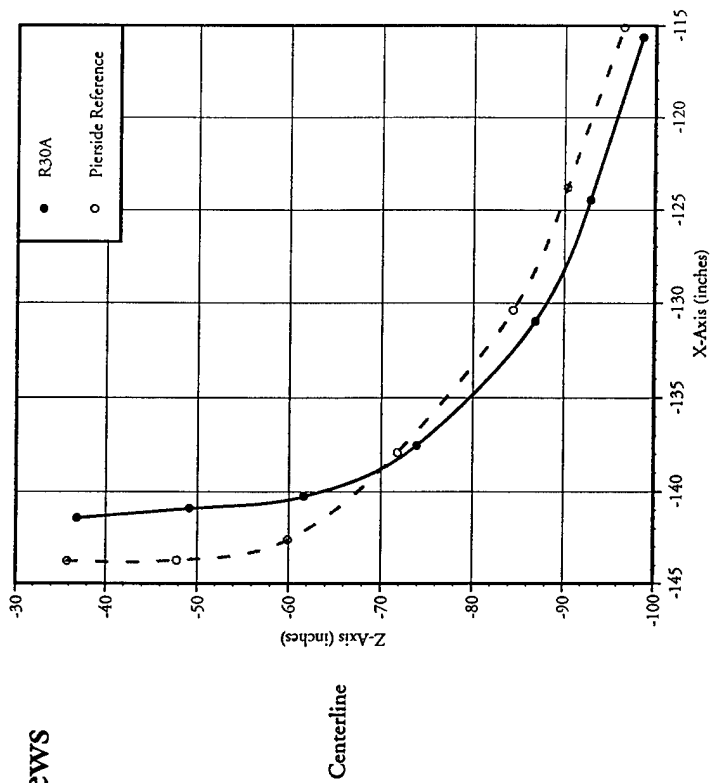

## Appendix 7

2-dimensional projection mappings of the horizontal and vertical deflections of the USS RADFORD monolithic sonar dome. For each component two graphs are shown. A two color shaded surface interpolation and a contour displacement plot.

For the top horizontal plot:

**Magenta** represents inward displacements

**Cyan** outward displacements.

For the vertical displacement plots:

**Magenta** represents downward displacements

**Cyan** upward displacements.

# Data Run: CAL5a

Ave. Ship Speed: 4.8 kts    Sea State: 3

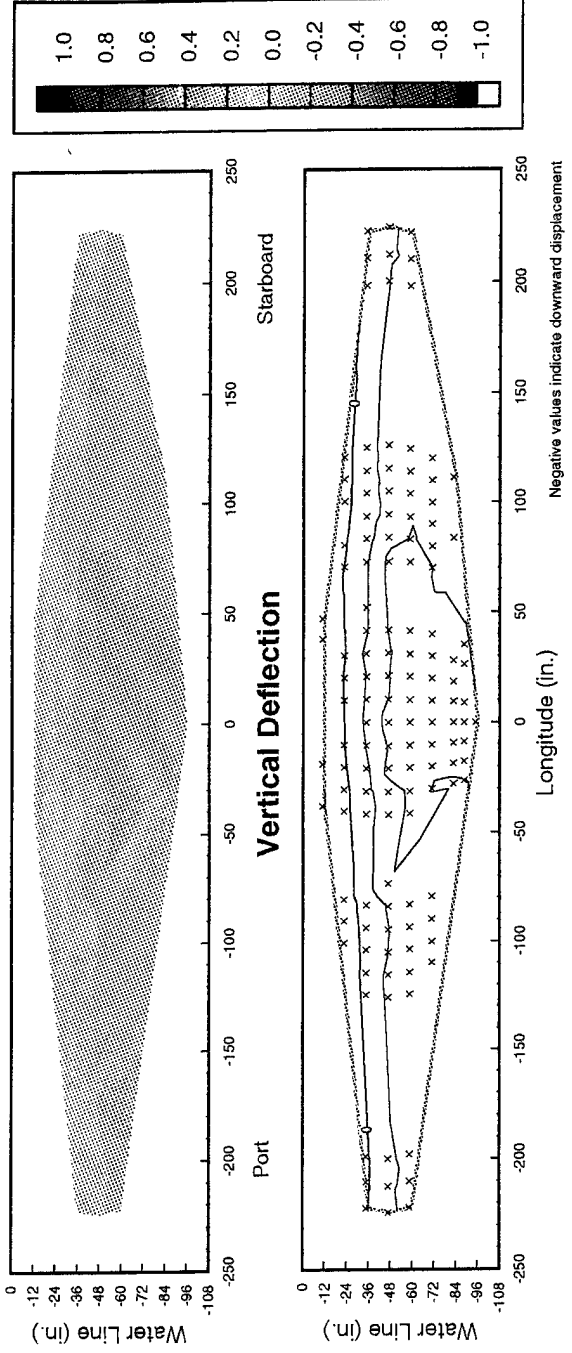
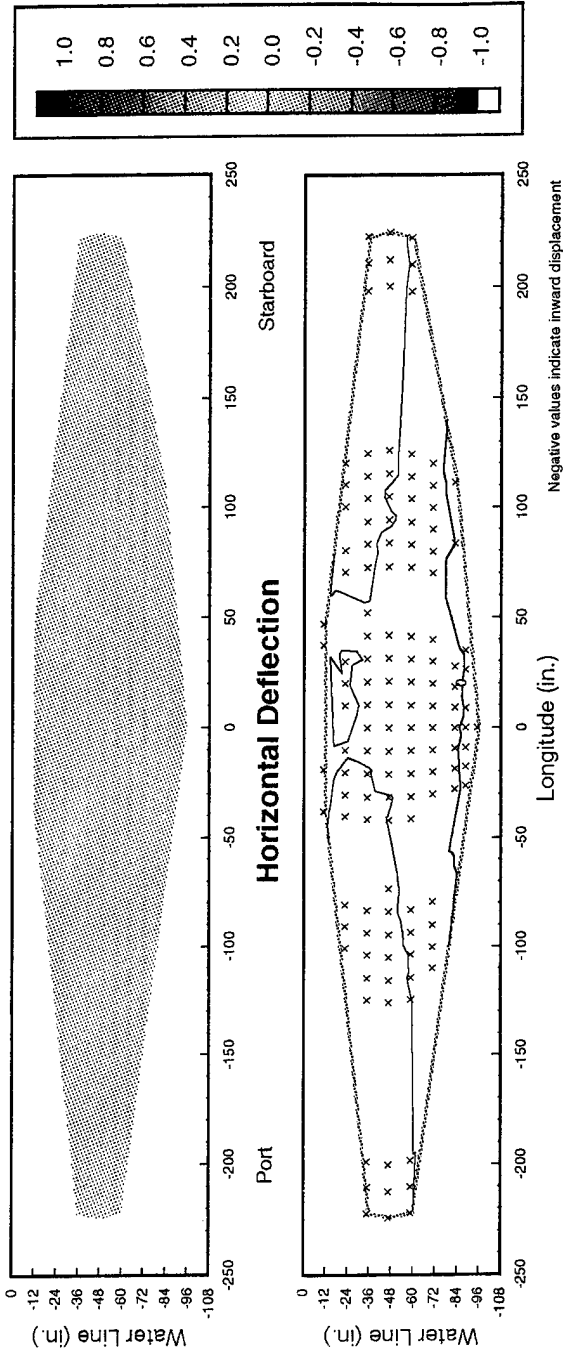

# Data Run: CAL10a

Ave. Ship Speed: 10.3 kts Sea State: 2

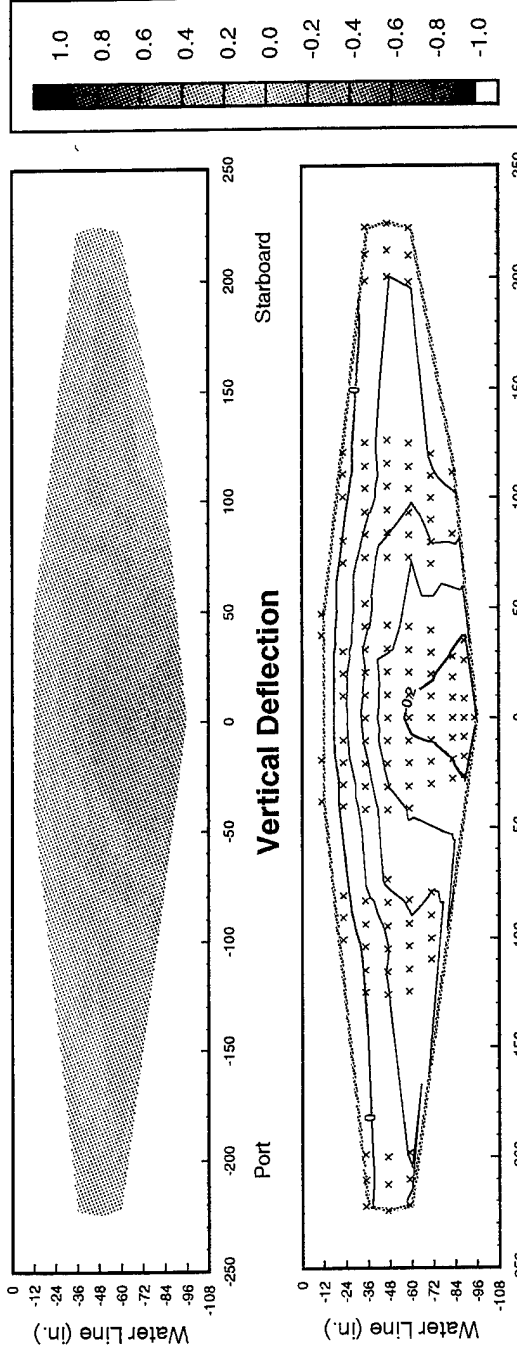
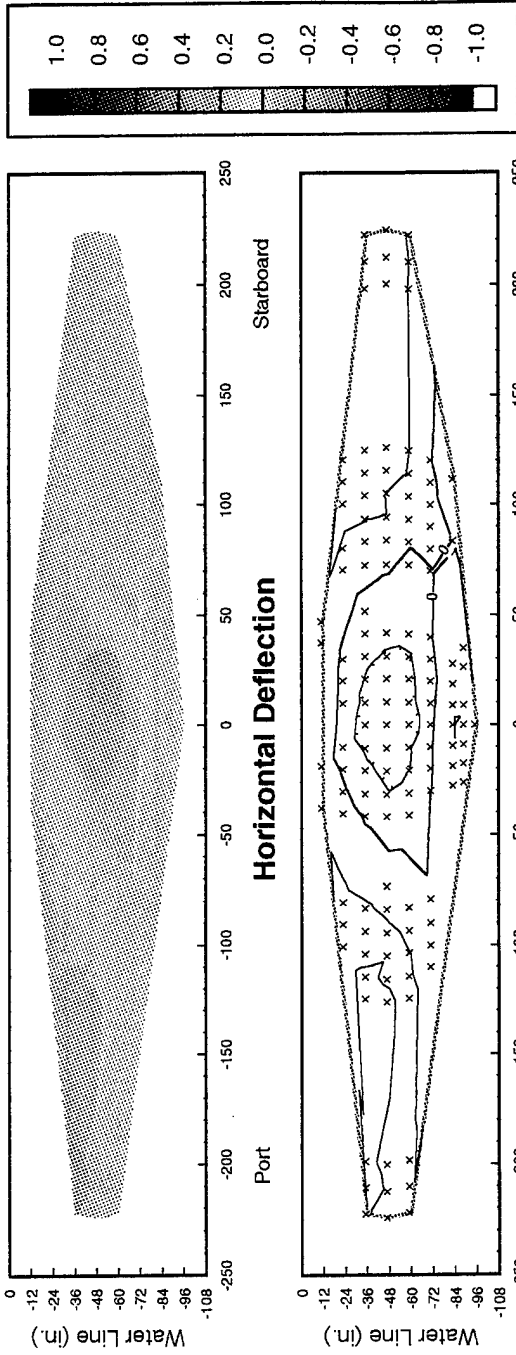

# Data Run: CAL15b

Ave. Ship Speed: 15.5 kts Sea State: 2

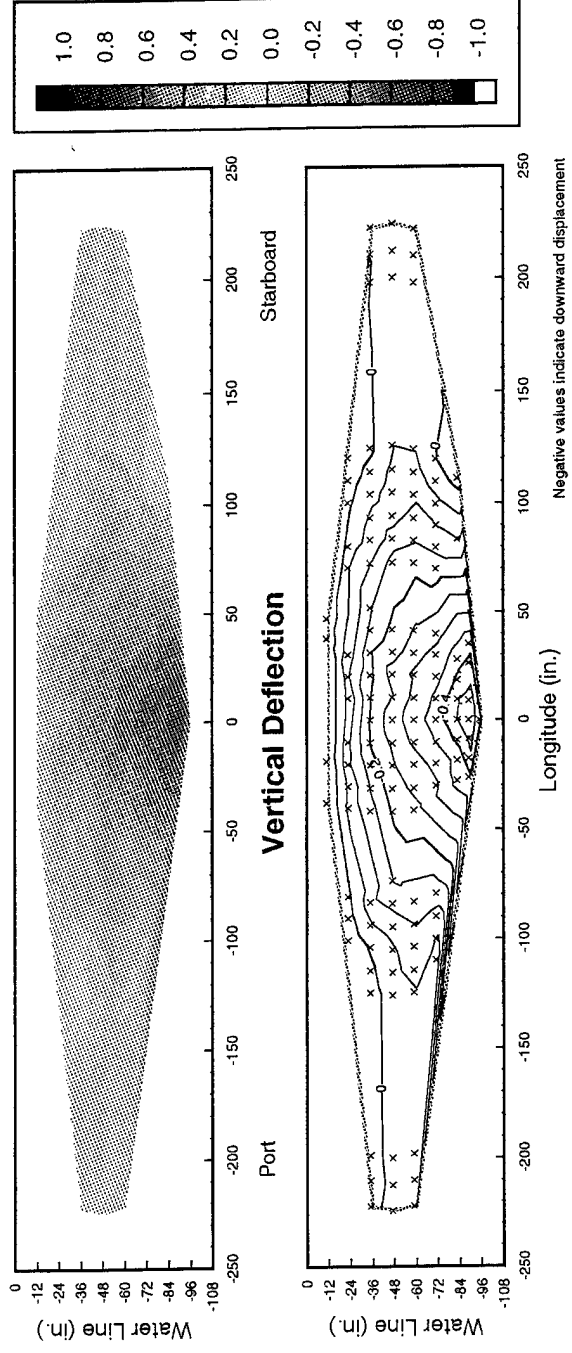
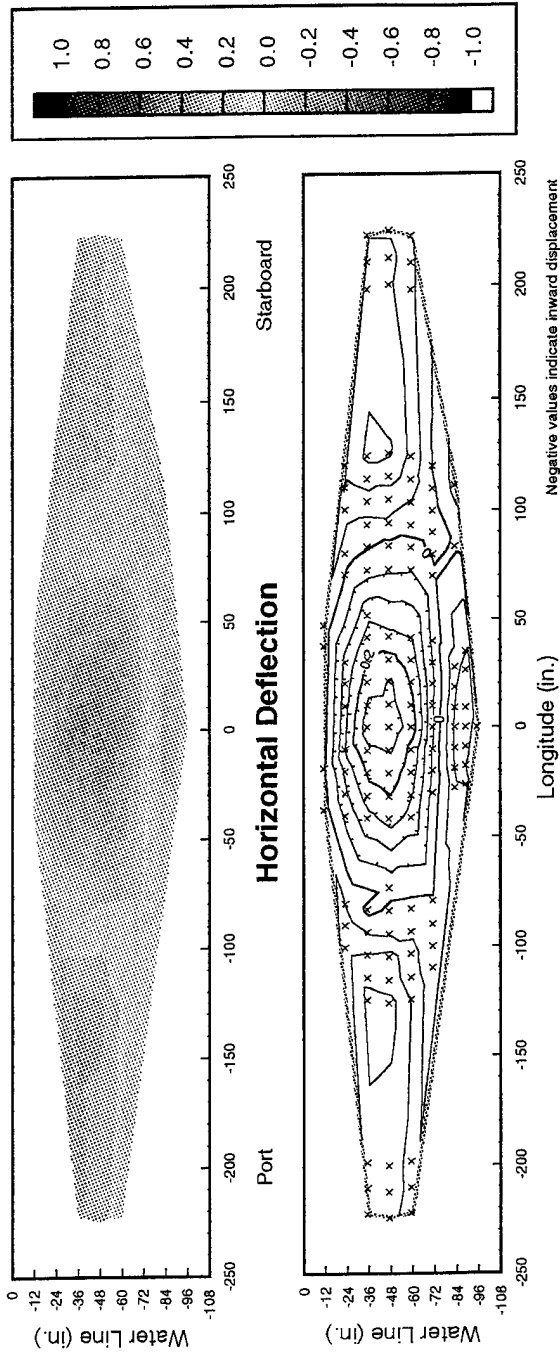

# Data Run: Rt16a

Ave. Ship Speed: 15.8 kts    Sea State: 3

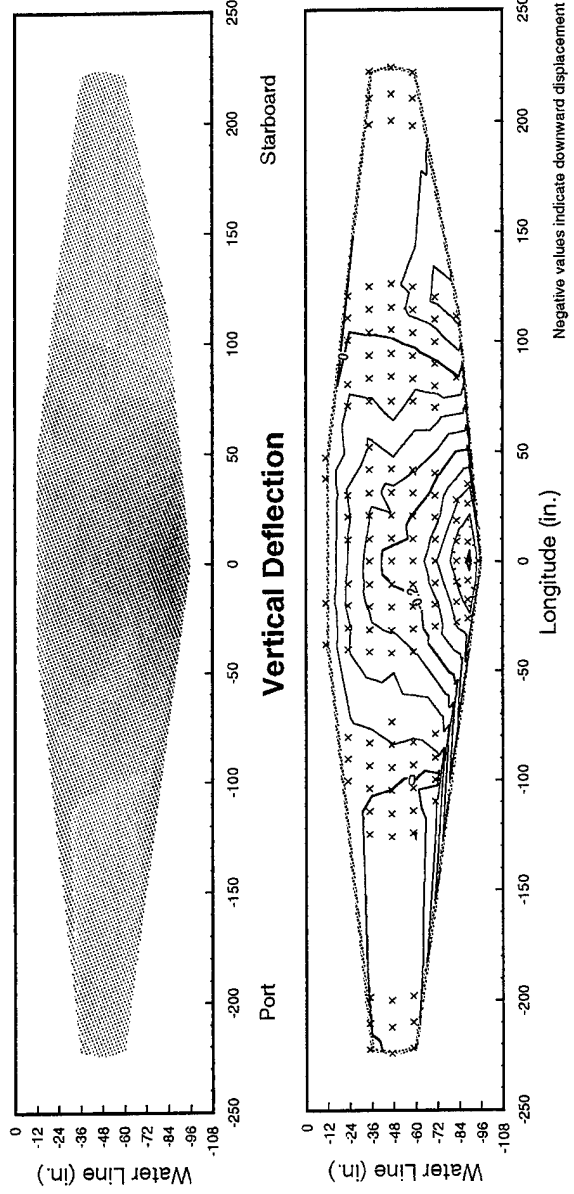
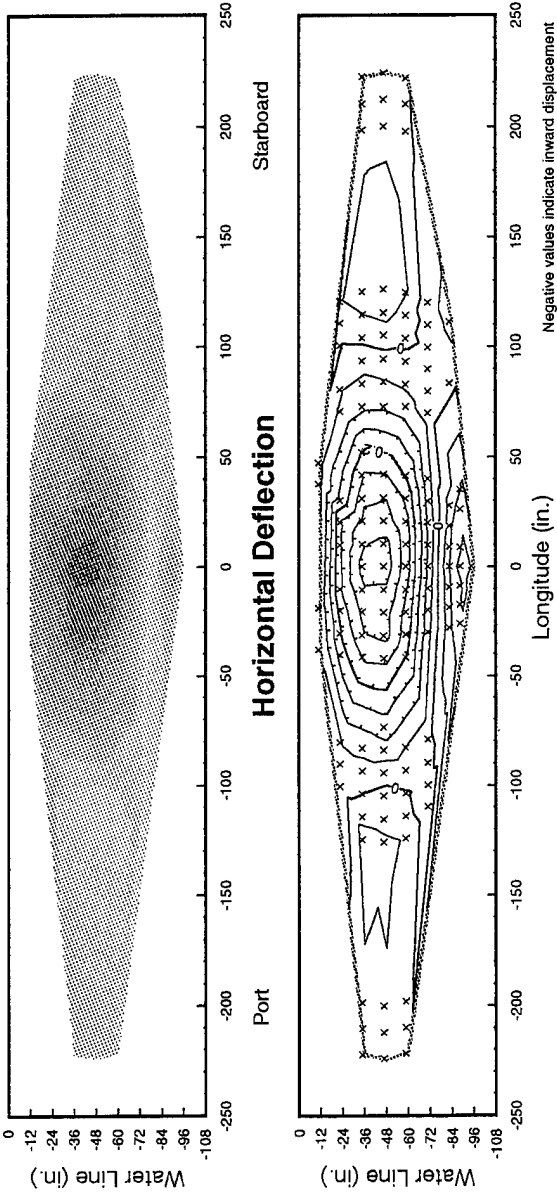

# Data Run: CAL15

Ave. Ship Speed: 15.9 kts Sea State: 2

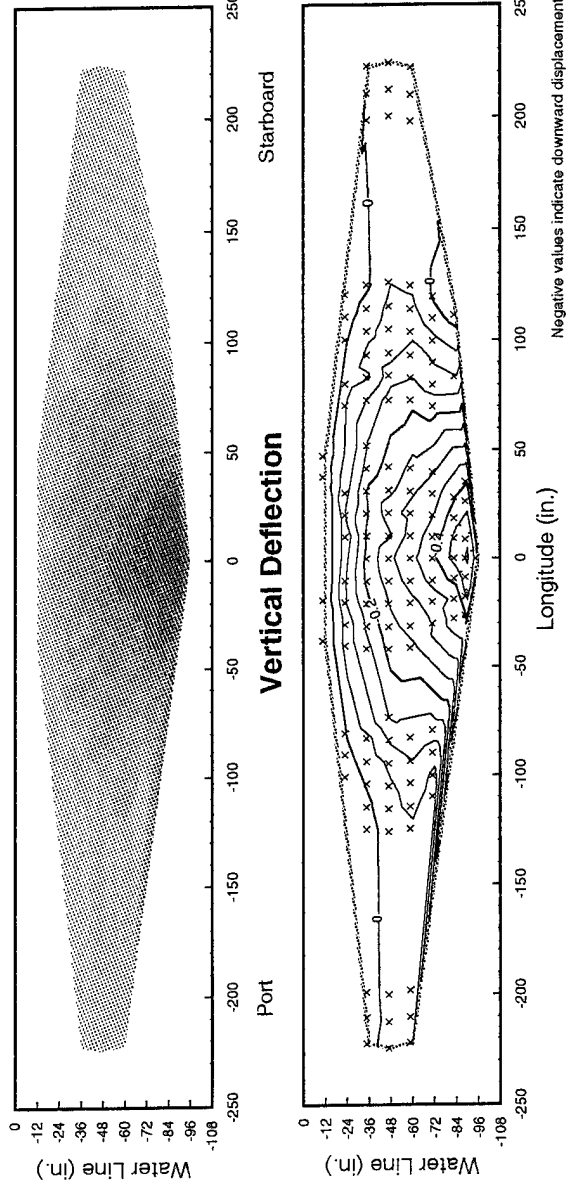
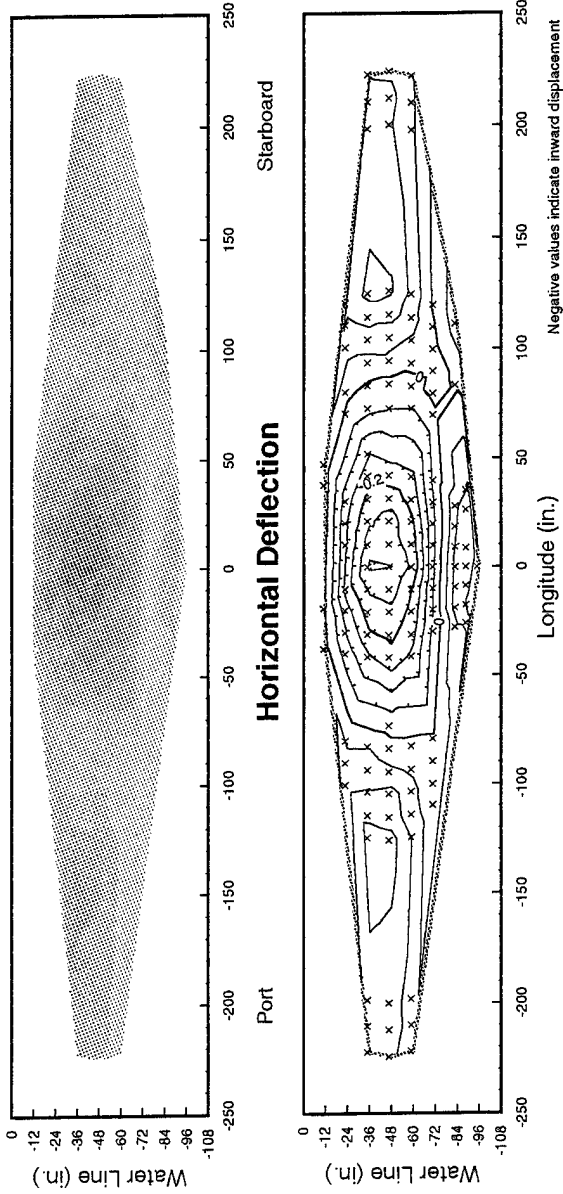

# Data Run: Rt17a

Ave. Ship Speed: 17.7 kts    Sea State: 3

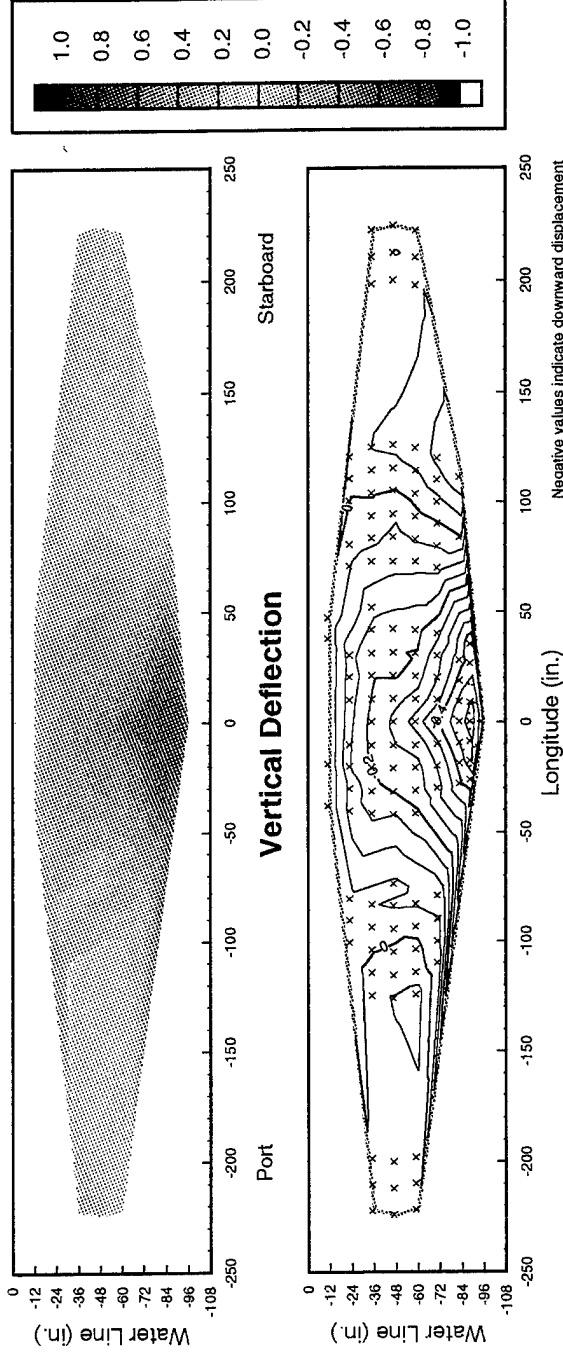
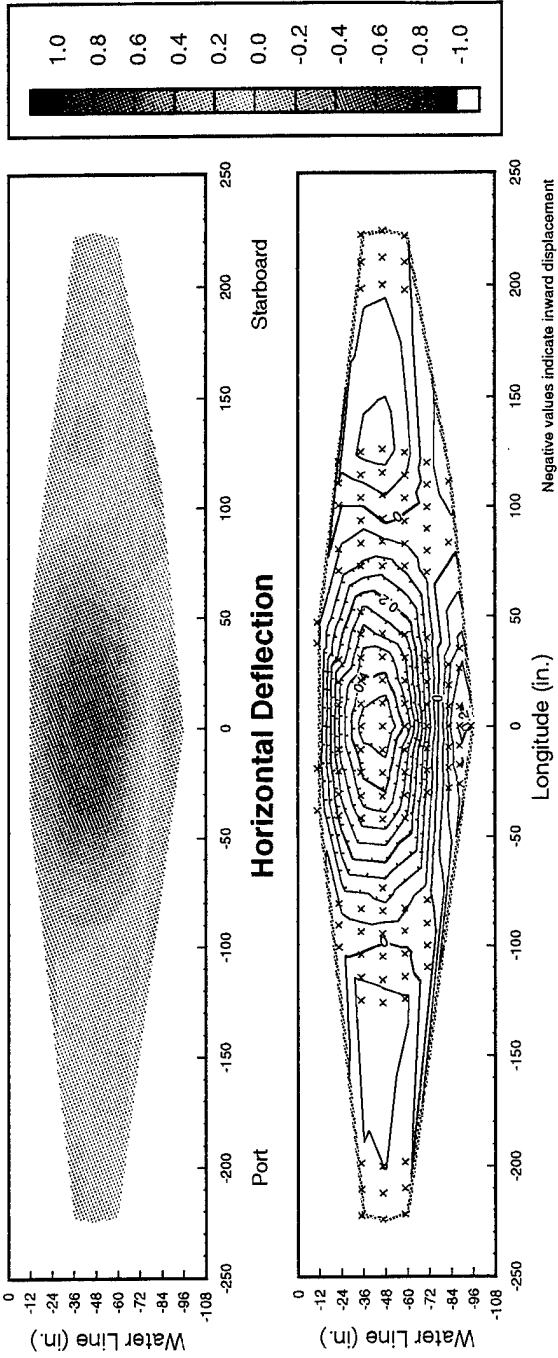



# Data Run: Rq18a

Ave. Ship Speed: 18.9 kts    Sea State: 3

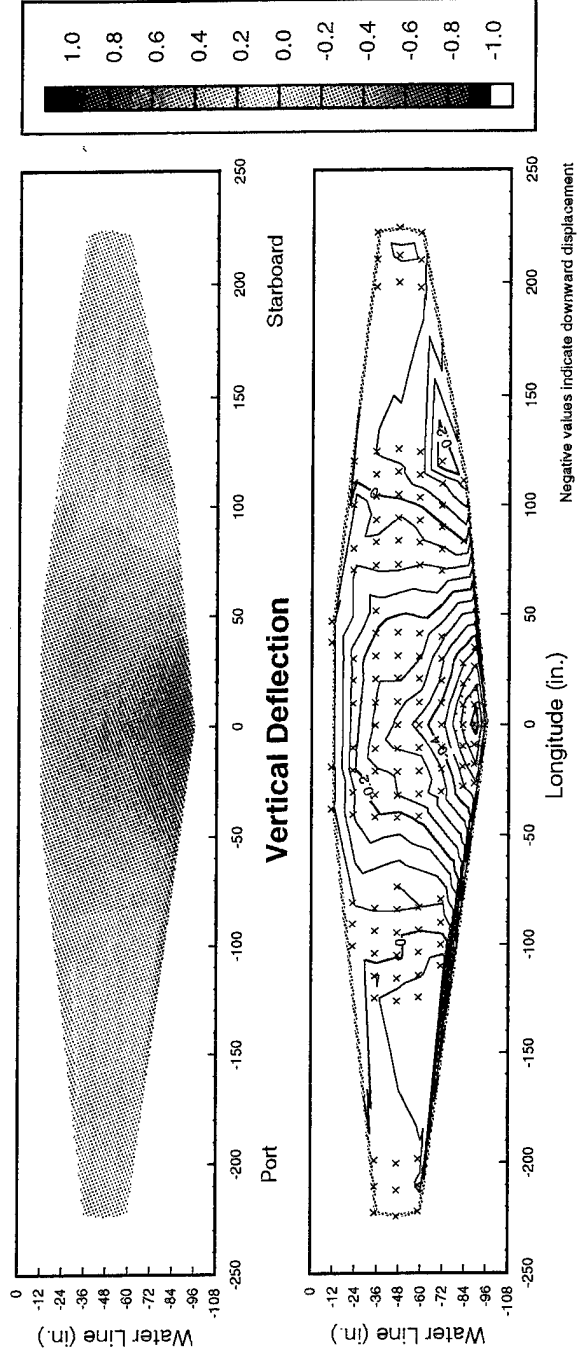
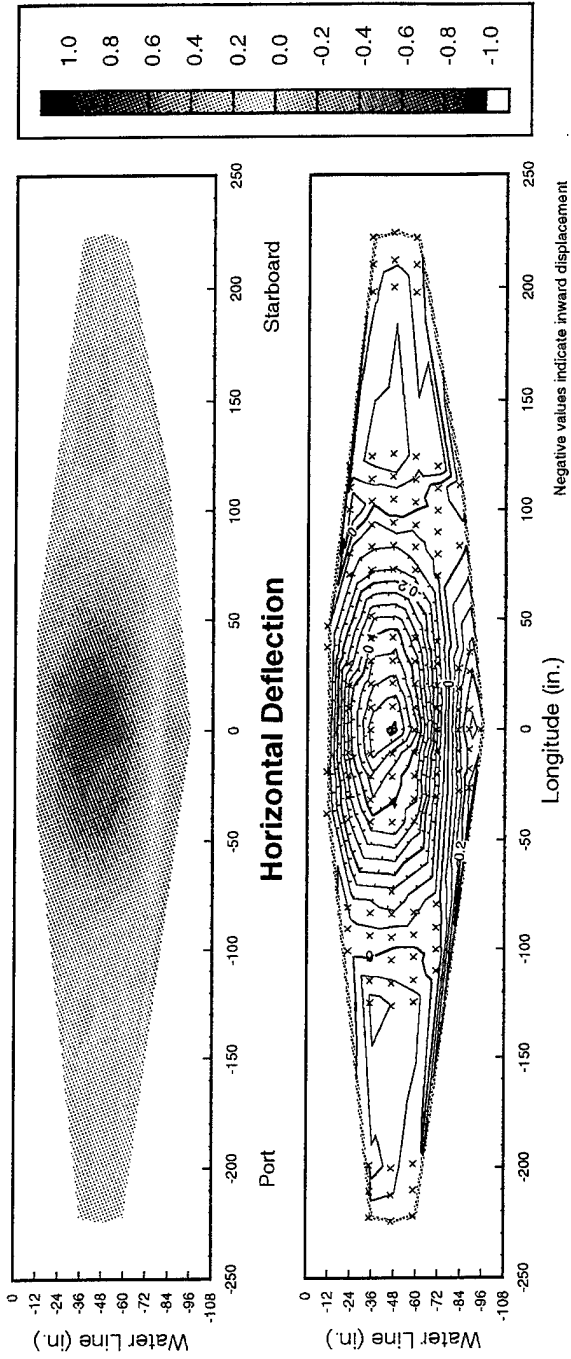

# Data Run: Rq18b

Ave. Ship Speed: 19.0 kts    Sea State: 3

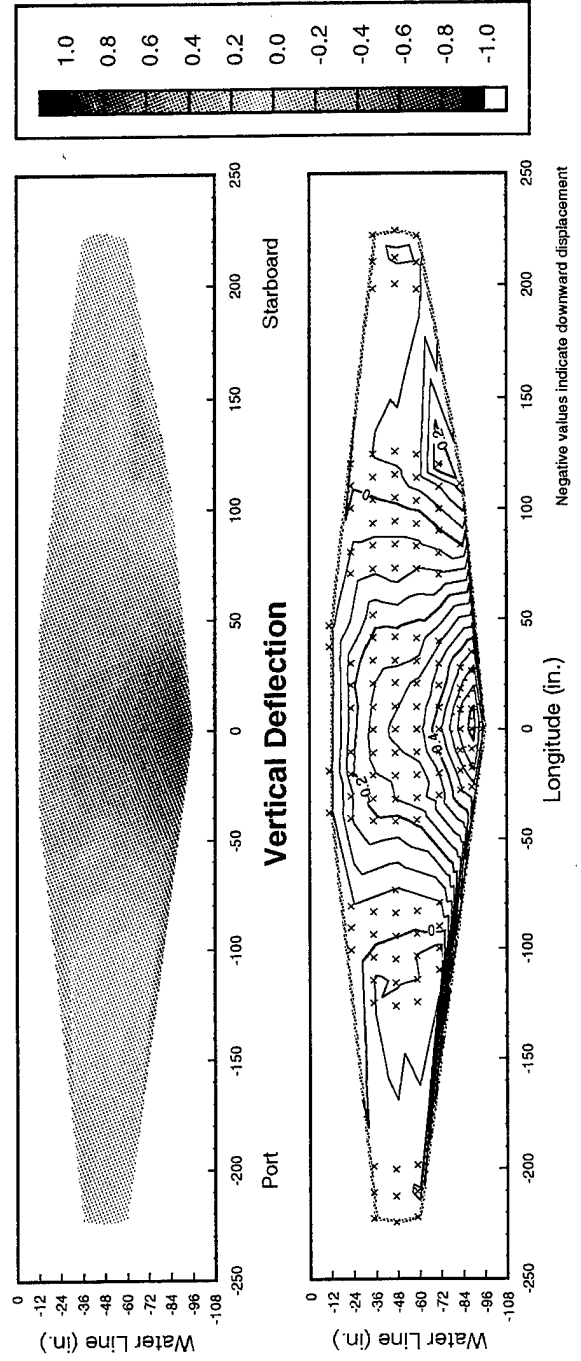
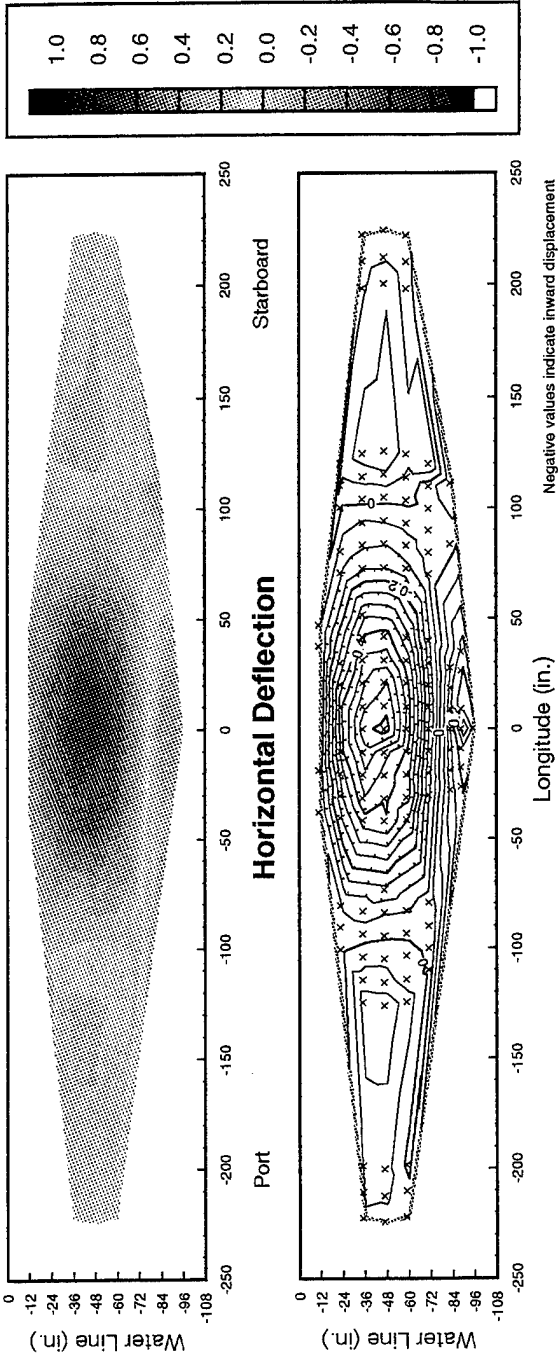

# Data Run: Rq19a

Ave. Ship Speed: 19.1 kts Sea State: 3

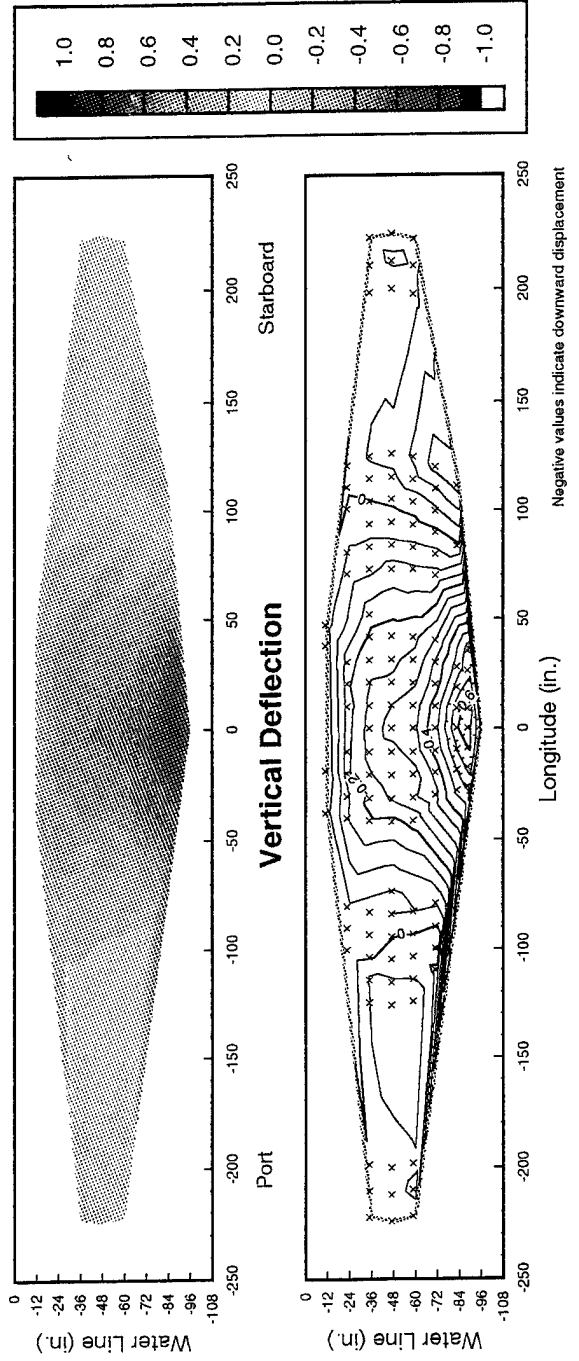
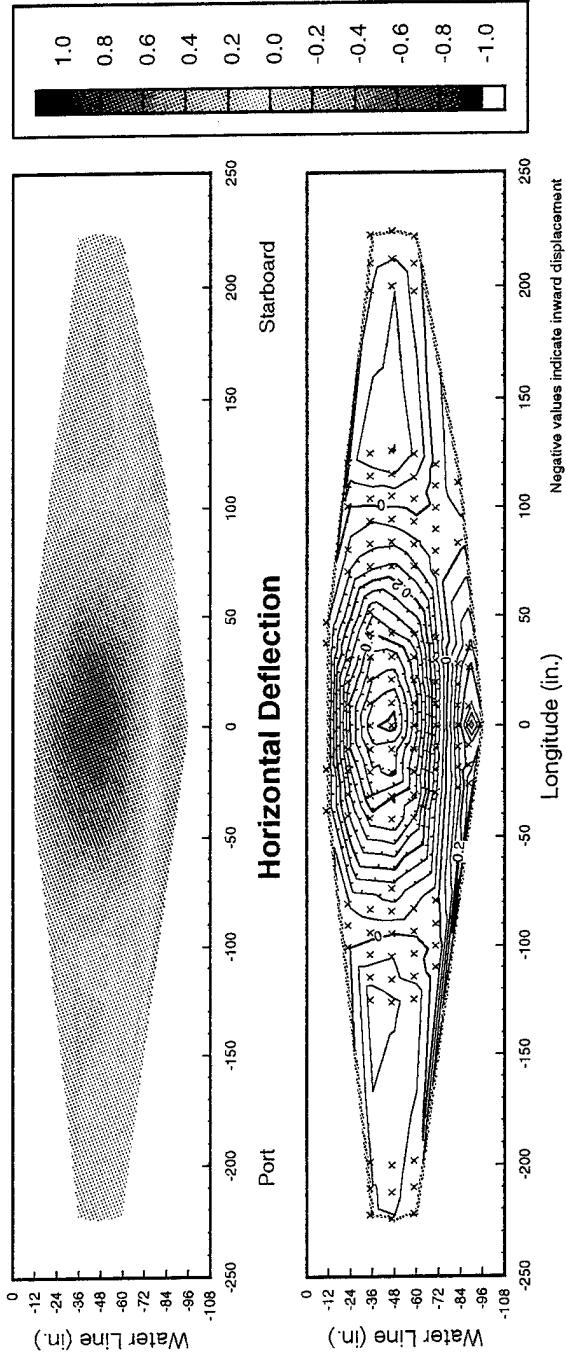

# Data Run: CAL19

Ave. Ship Speed: 19.4 kts Sea State: 2

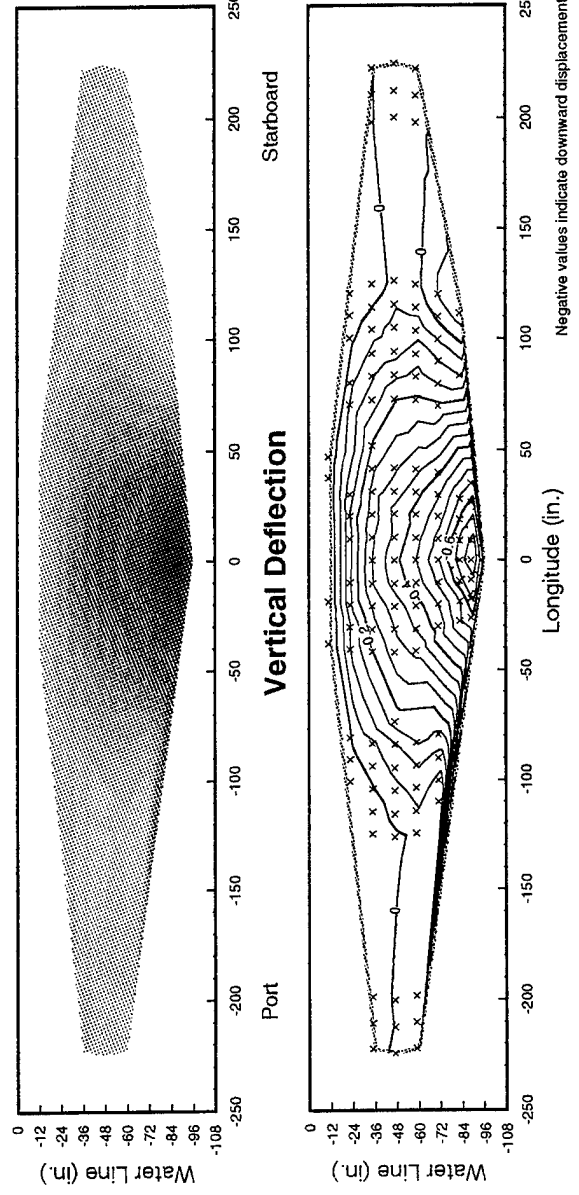
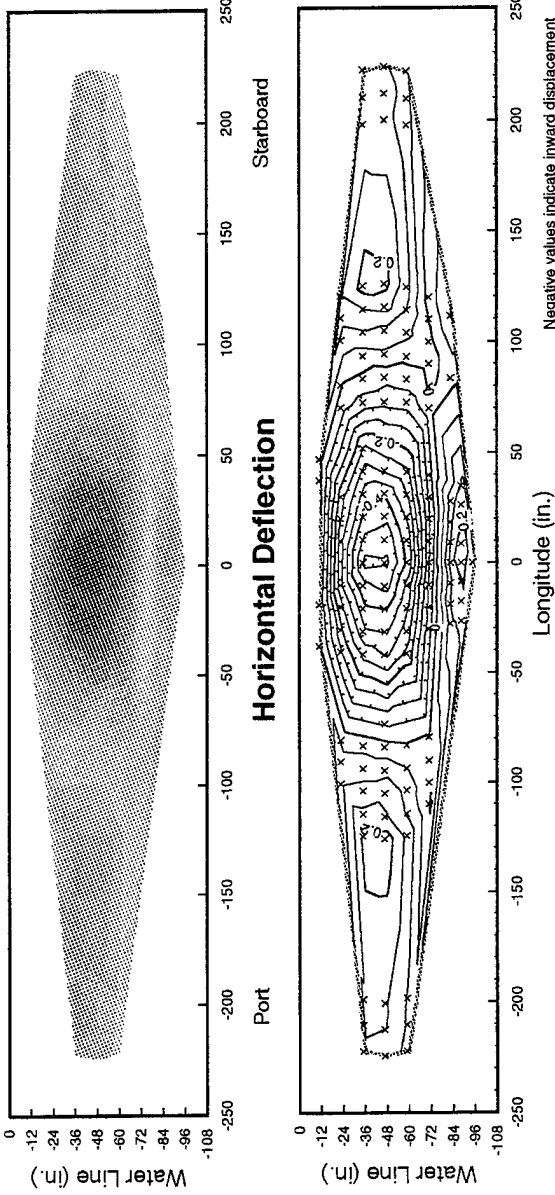

# Data Run: RC20a

Ave. Ship Speed: 20.2 kts Sea State: 2

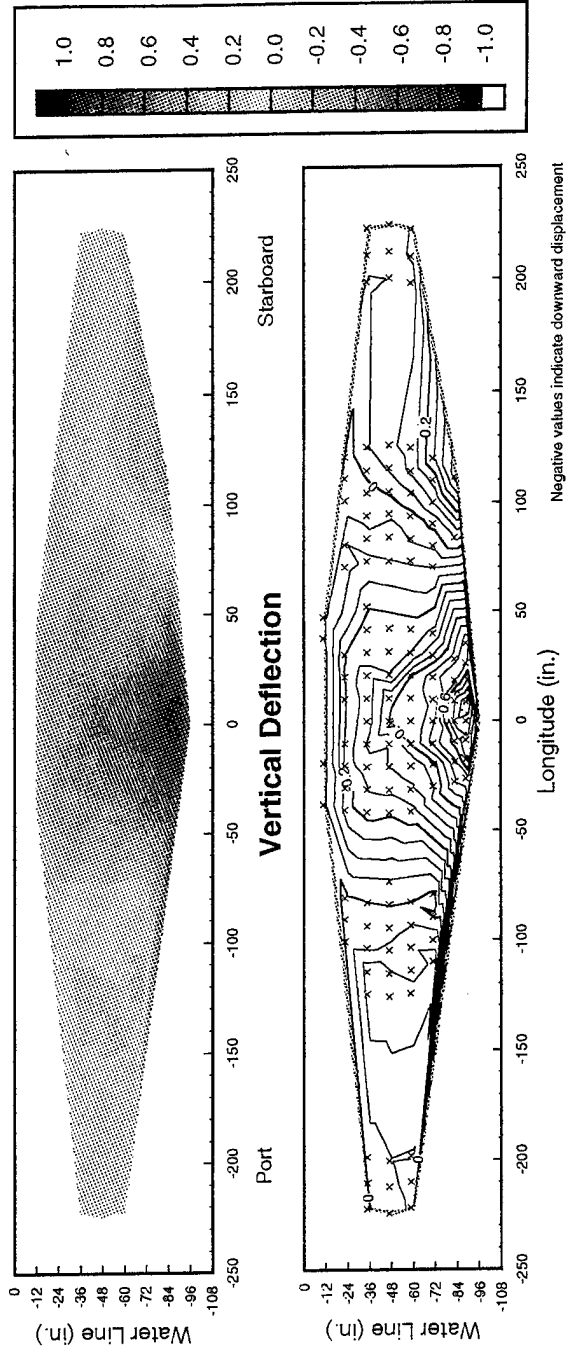
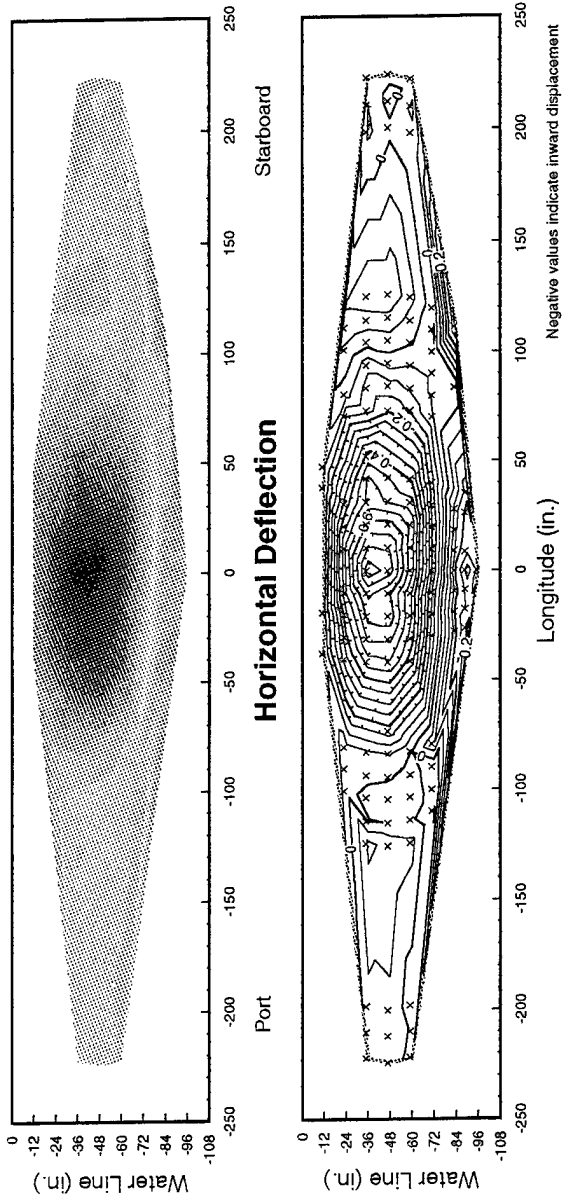

# Data Run: RC20b

Ave. Ship Speed: 20.3 kts    Sea State: 2

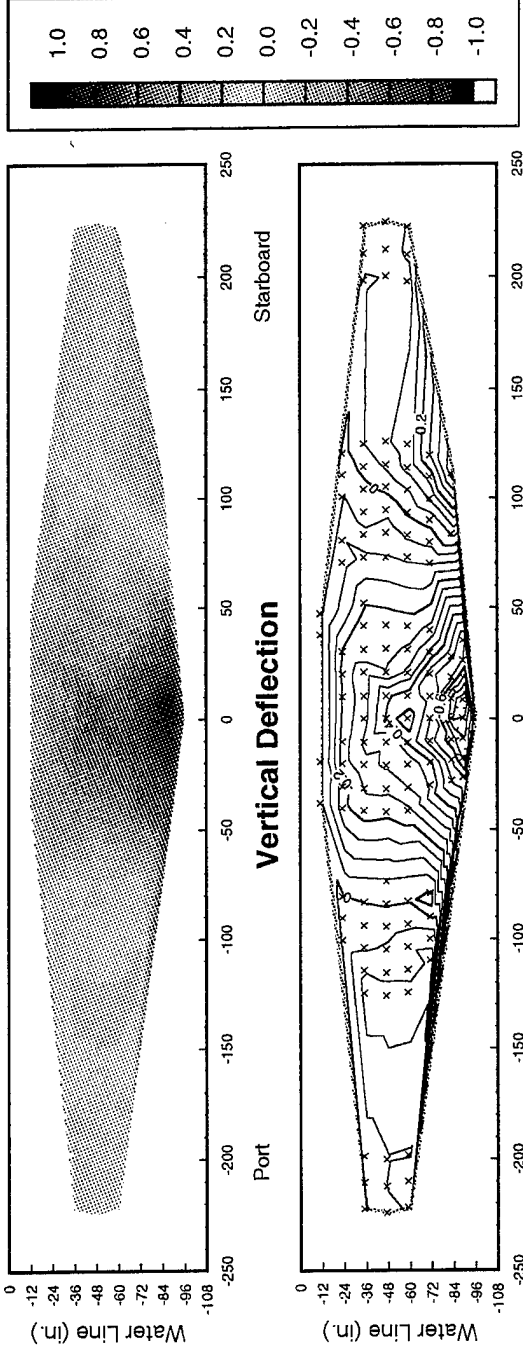
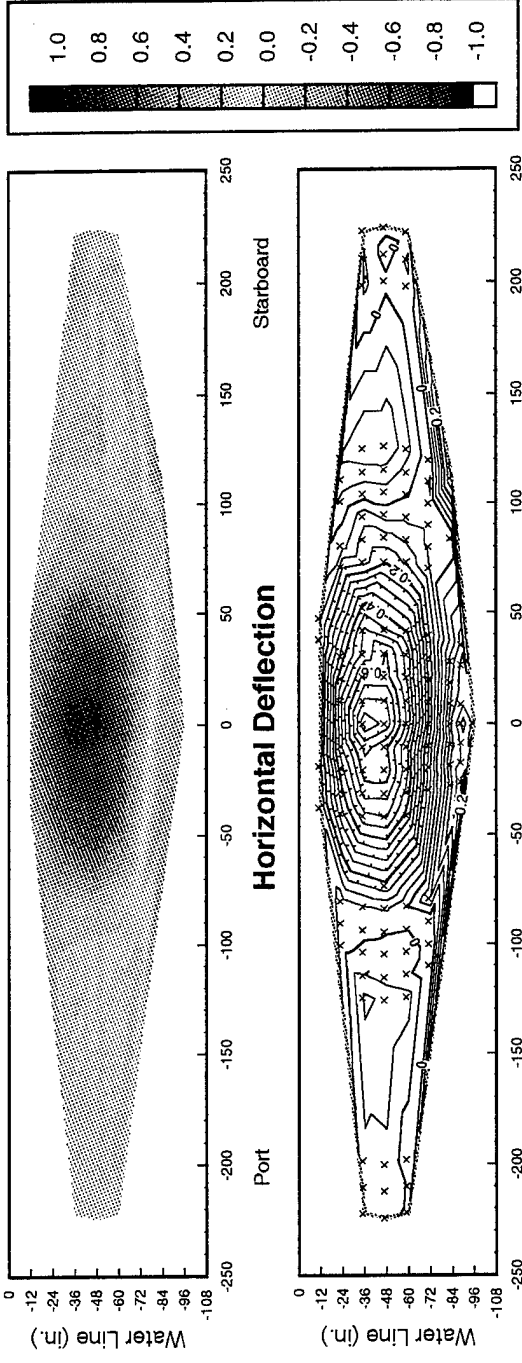

# Data Run: CAL20

Ave. Ship Speed: 20.4 kts Sea State: 3

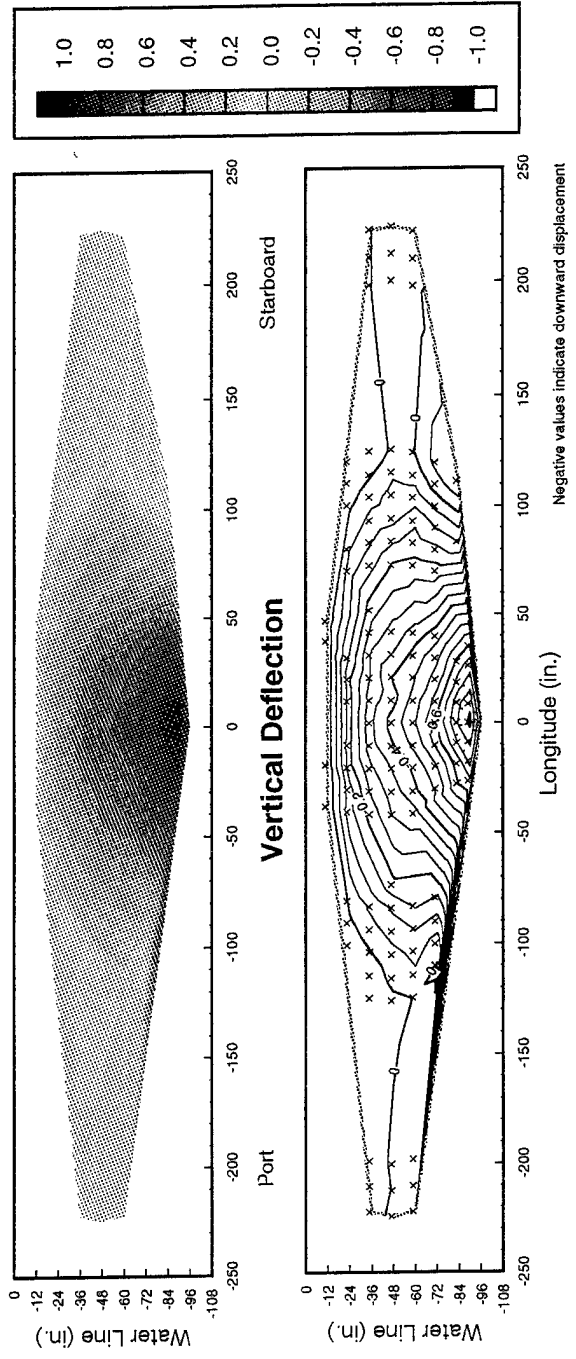
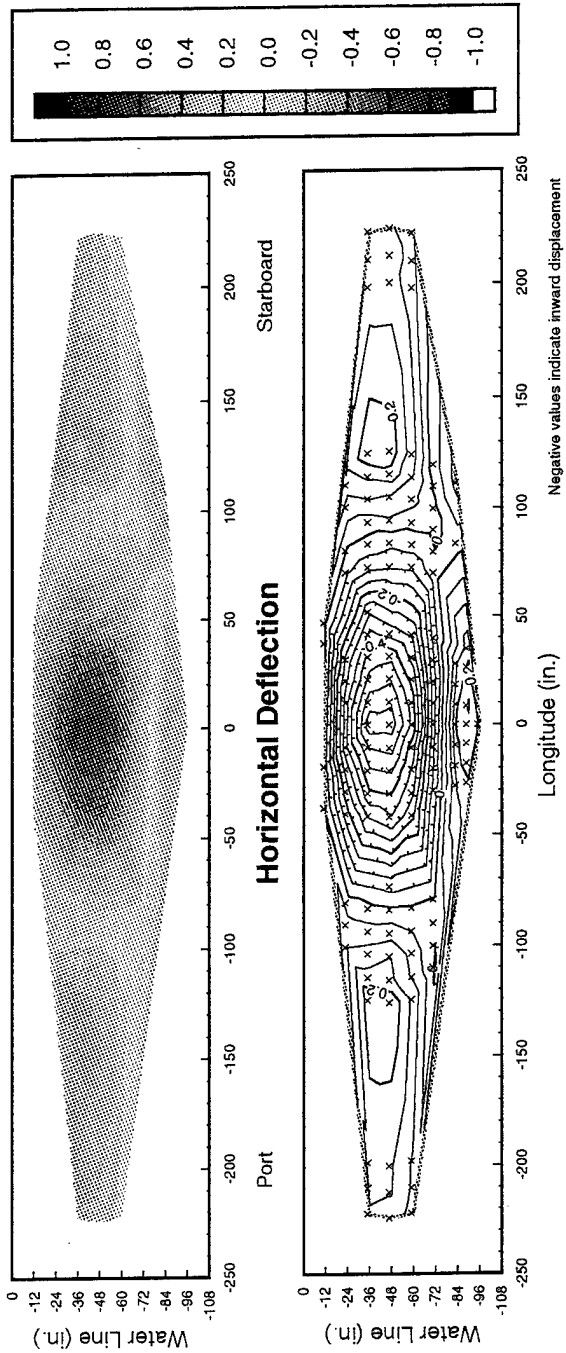

# Data Run: Rp20b

Ave. Ship Speed: 20.7 kts Sea State: 4

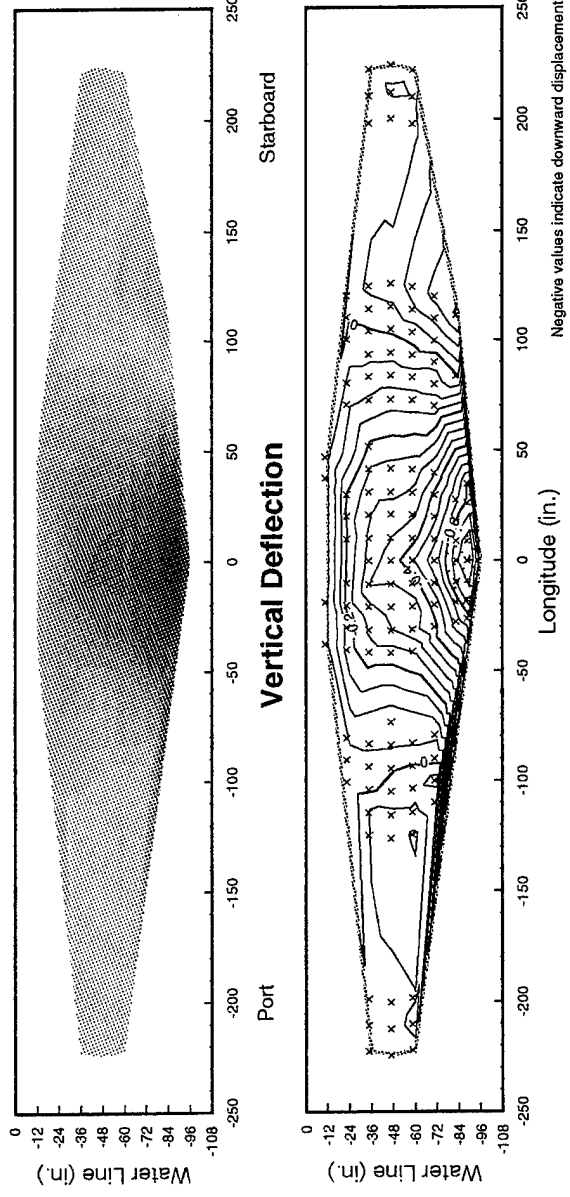
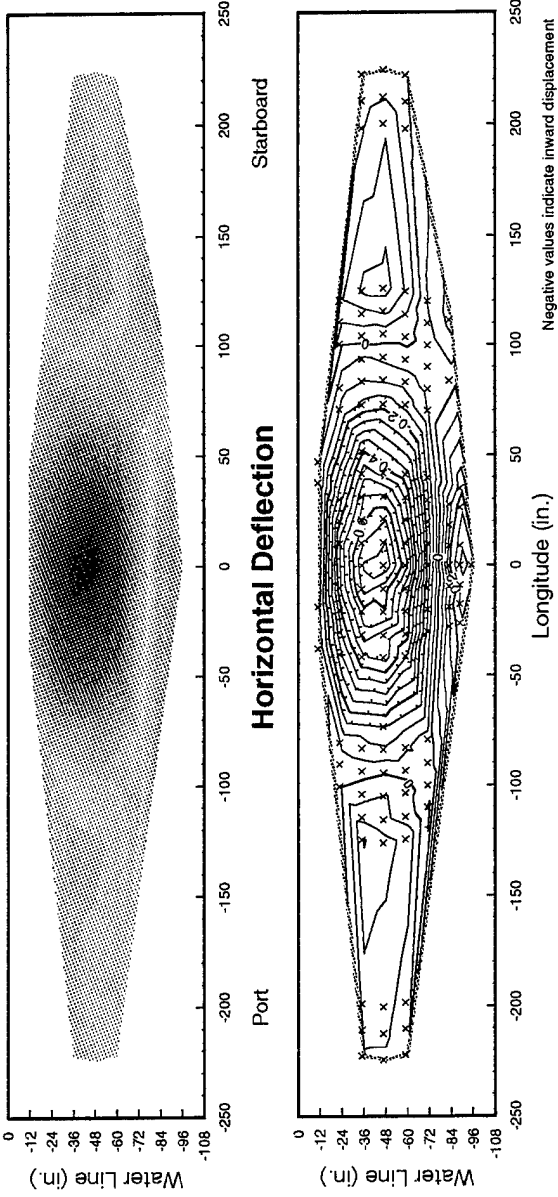



# Data Run: Rp20a

Ave. Ship Speed: 20.8 kts Sea State: 3

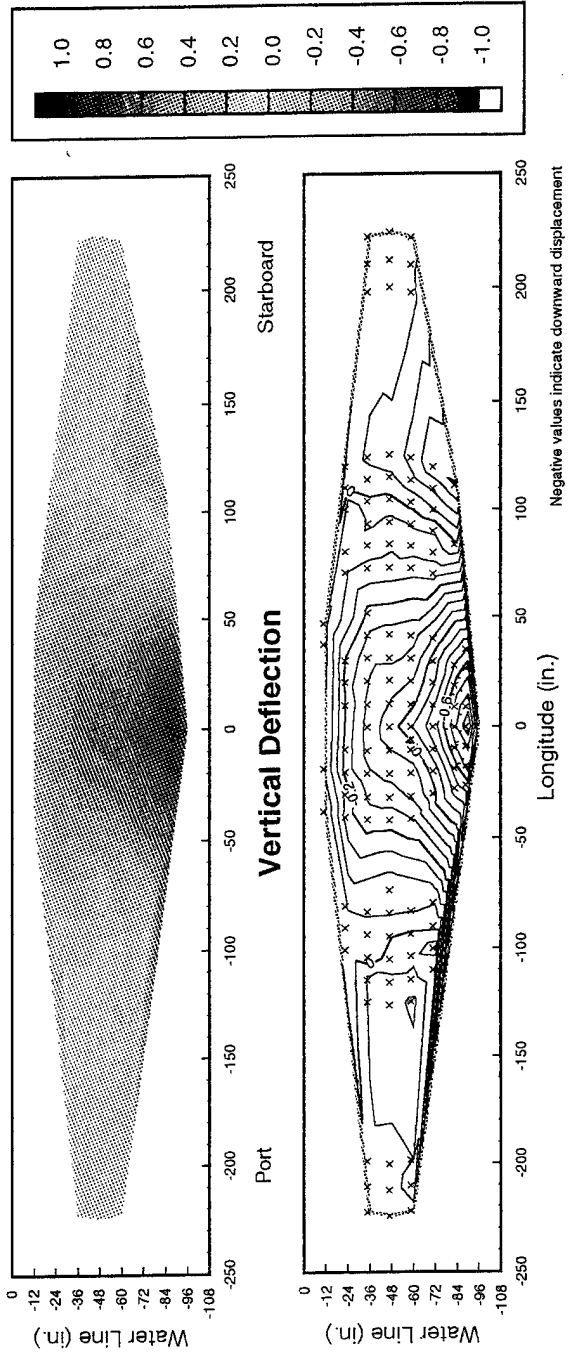
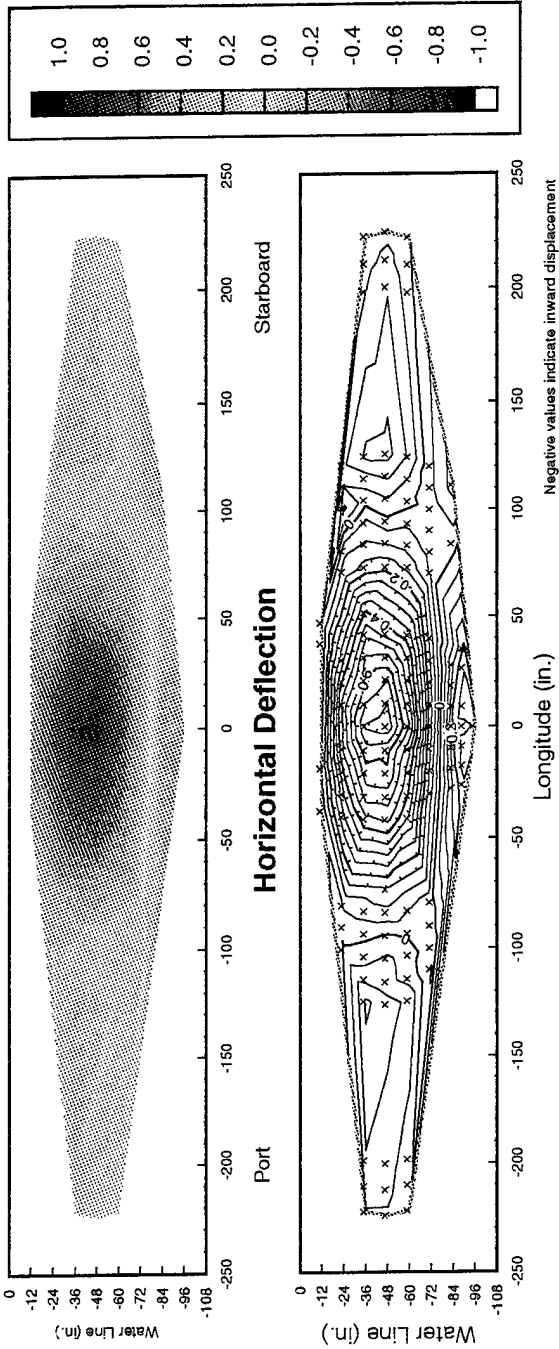

# Data Run: RL21a

Ave. Ship Speed: 21.1 kts Sea State: 3

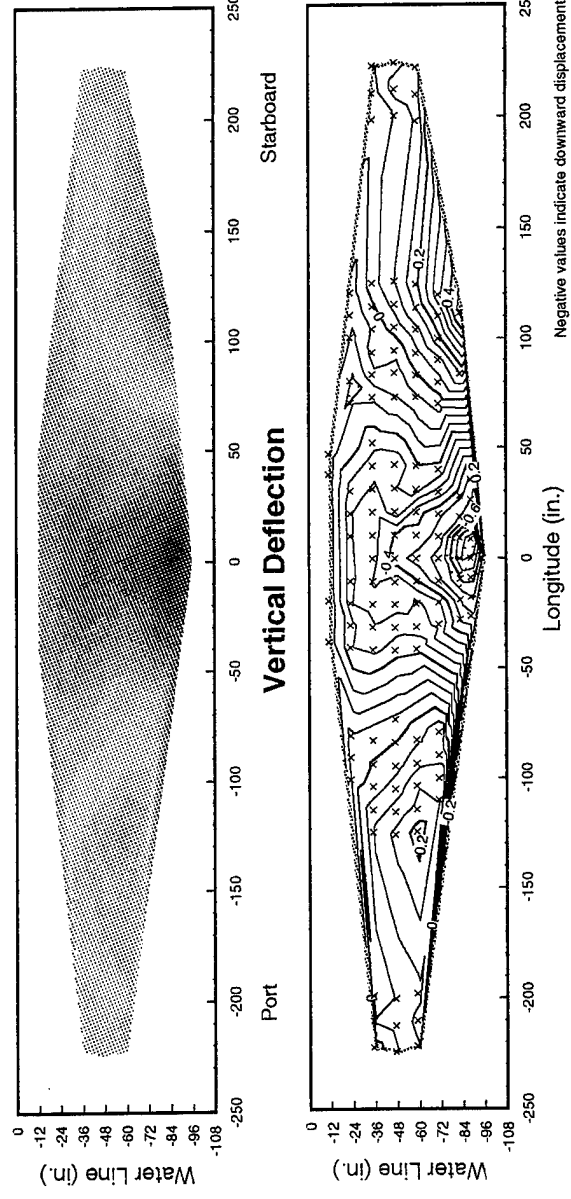
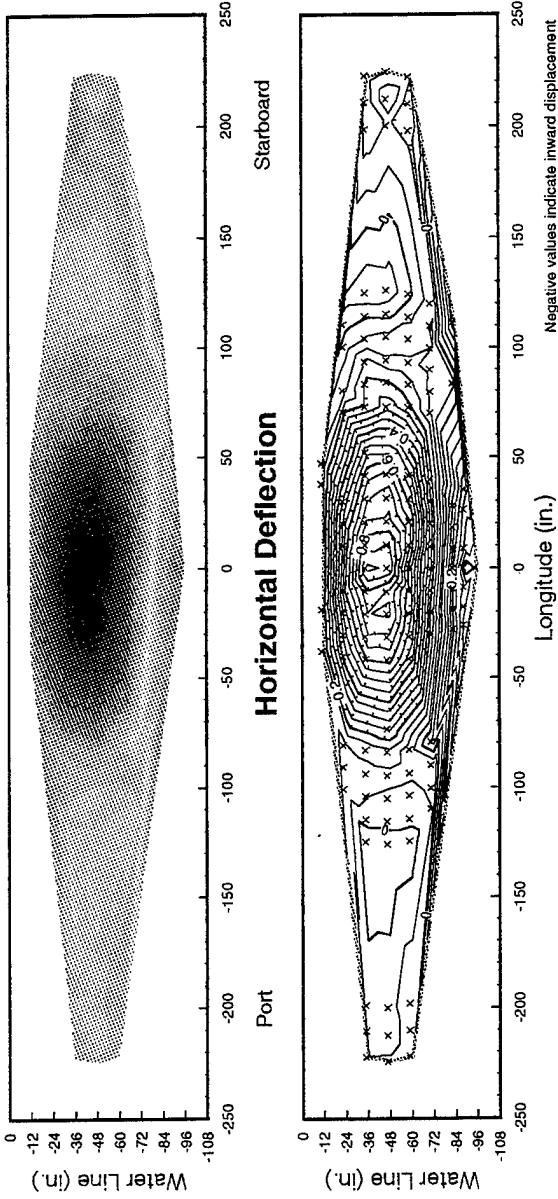

# Data Run: RL21C

Ave. Ship Speed: 21.1 kts    Sea State: 2

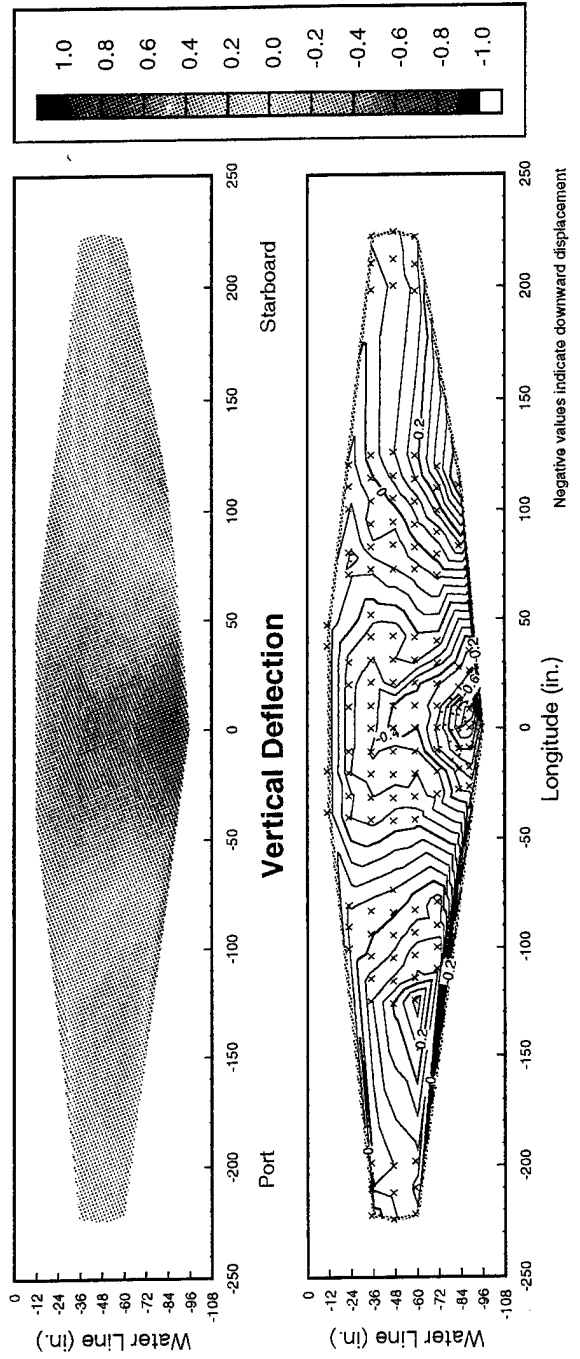
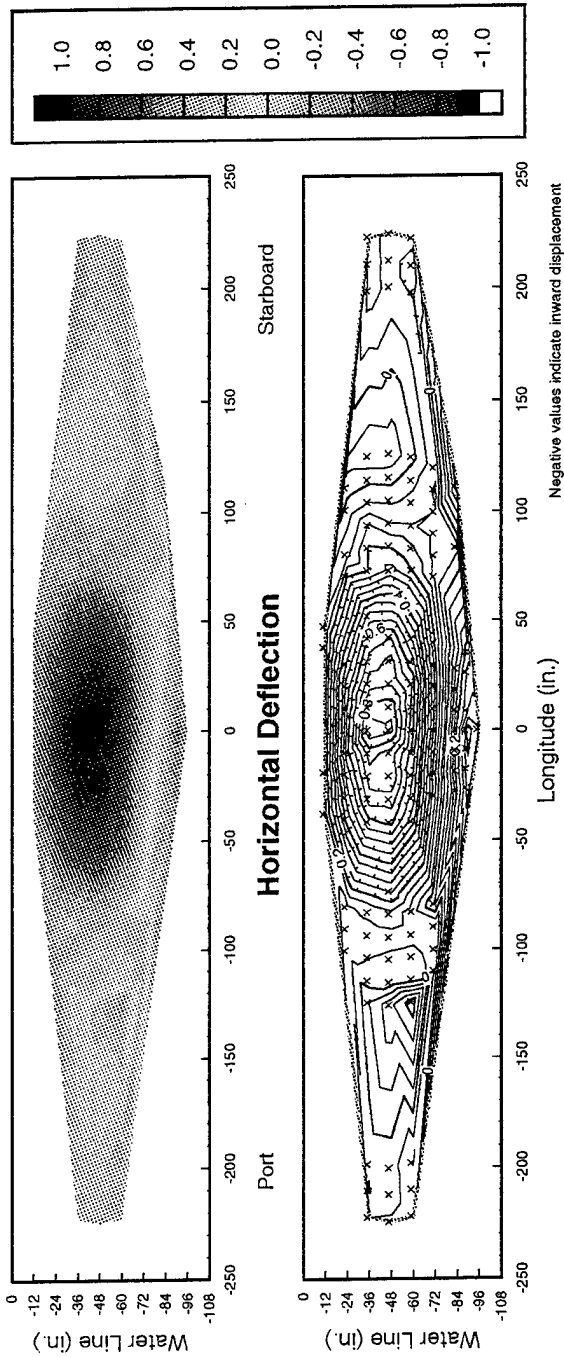

# Data Run: RL21b

Ave. Ship Speed: 21.2 kts Sea State: 2

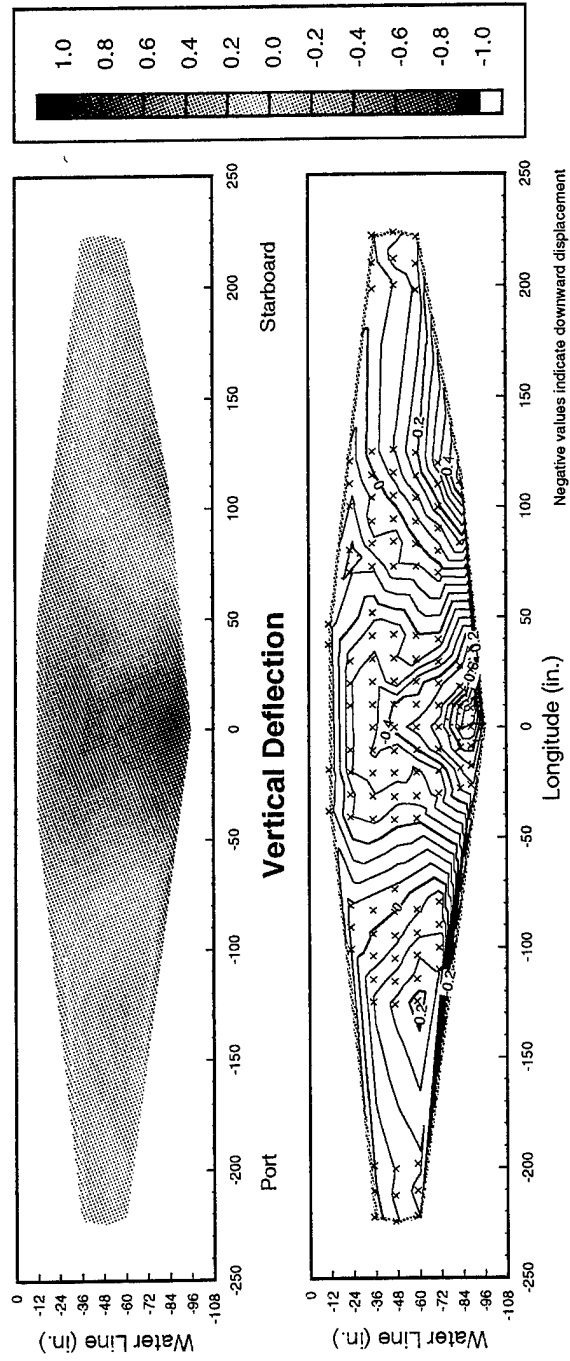
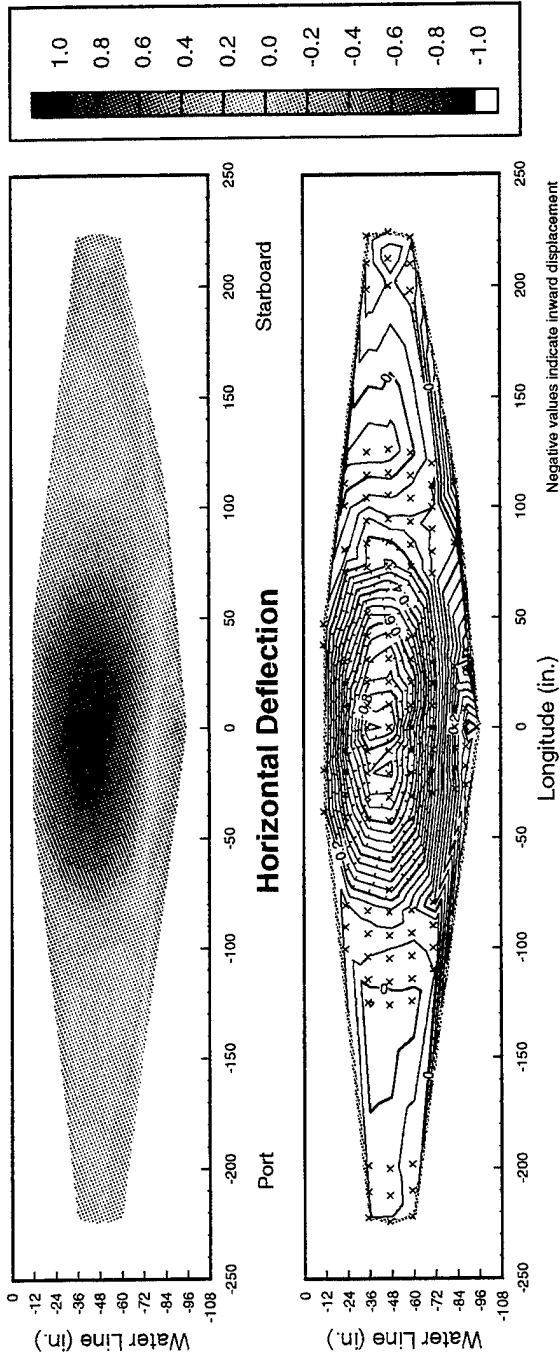

# Data Run: RL21d

Ave. Ship Speed: 21.2 kts Sea State: 2

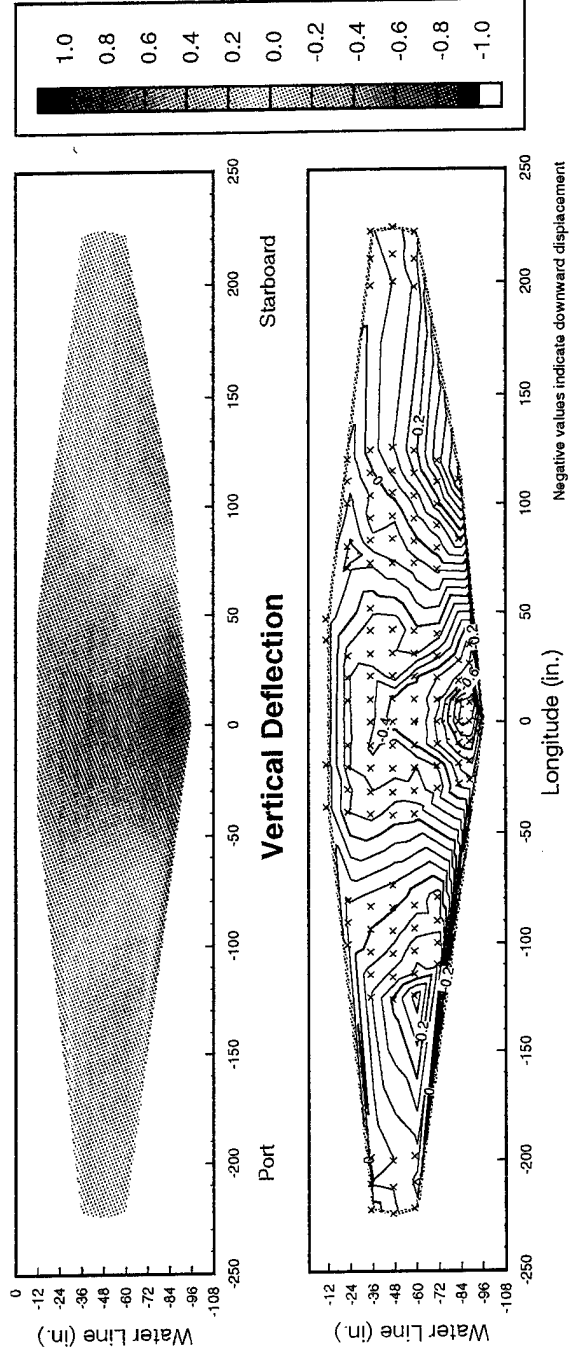
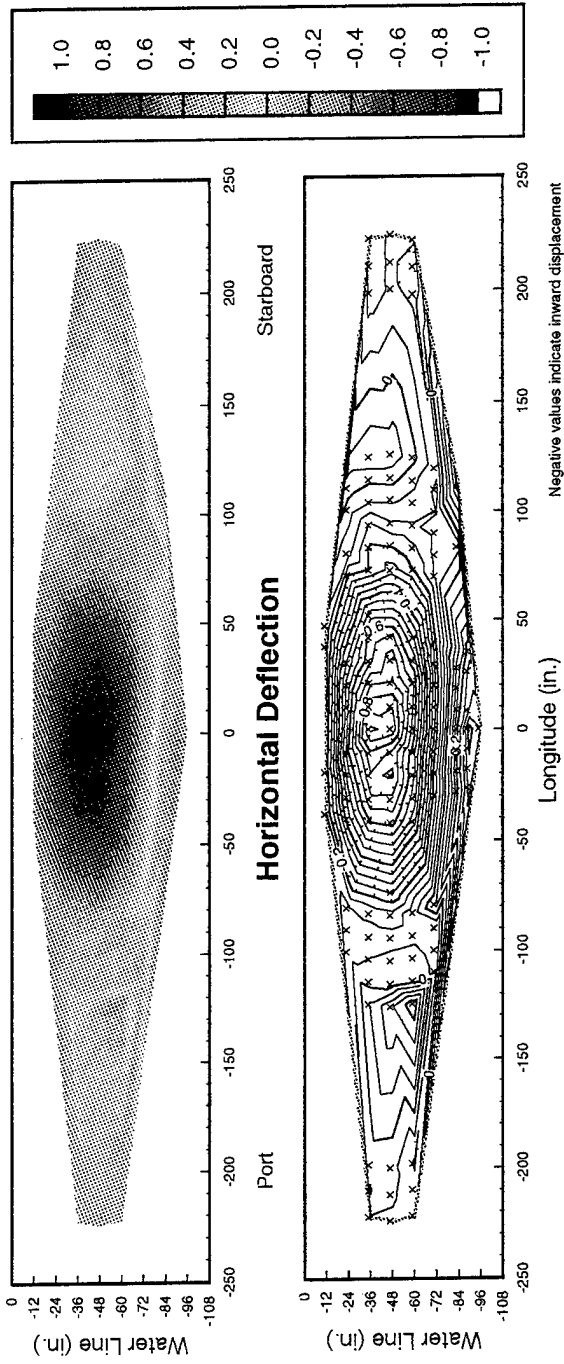

# Data Run: Rp21a

Ave. Ship Speed: 23.2 kts    Sea State: 3

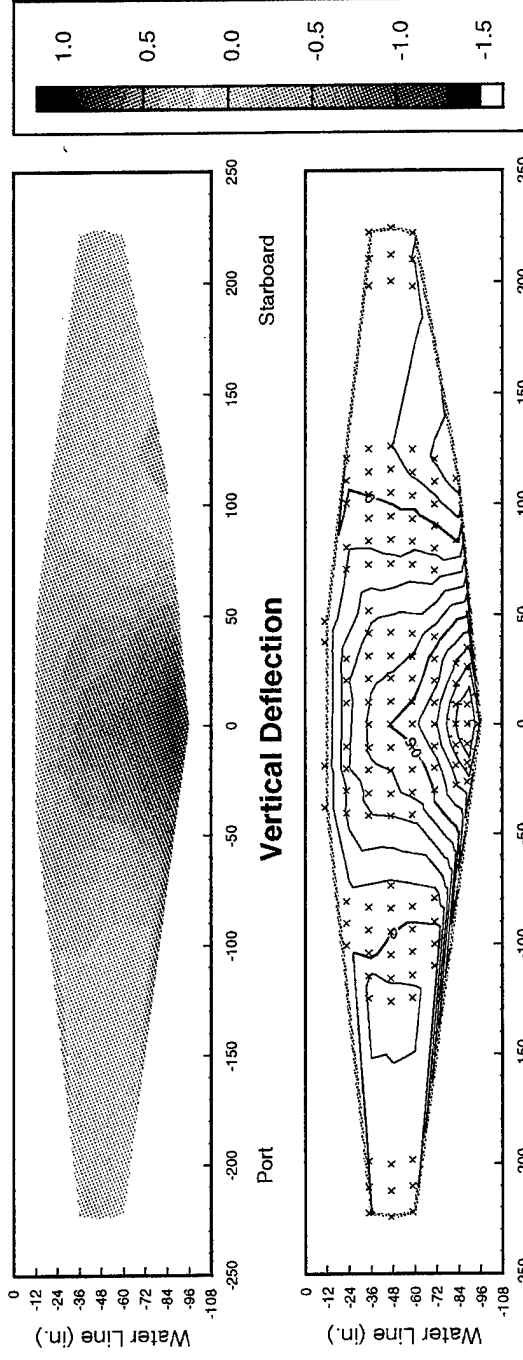
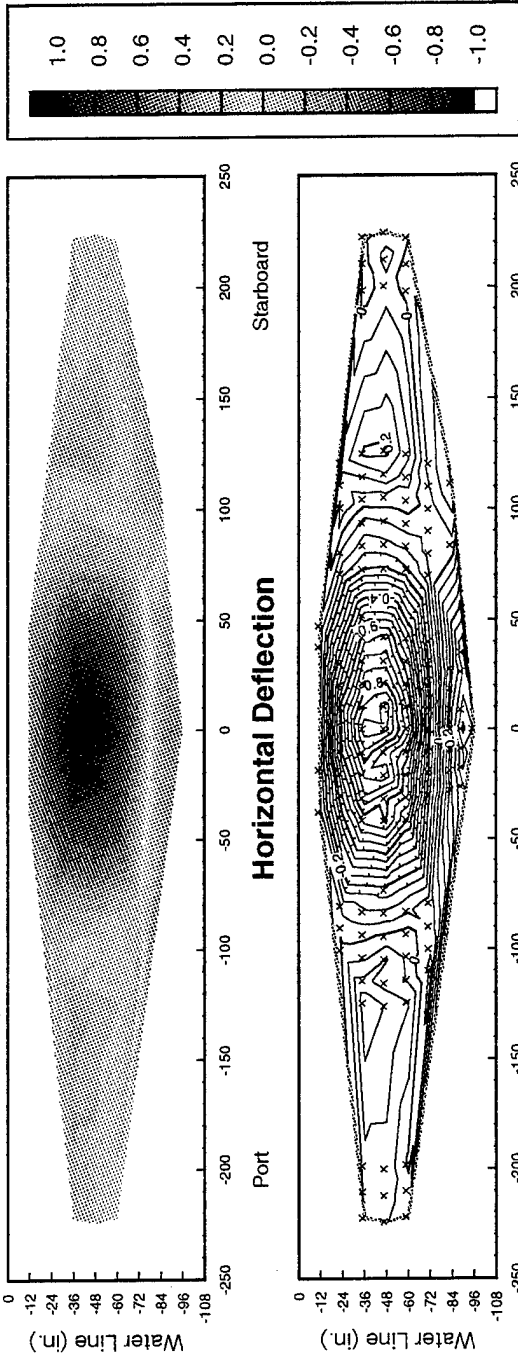

# Data Run: RL23a

Ave. Ship Speed: 23.4 kts Sea State: 2

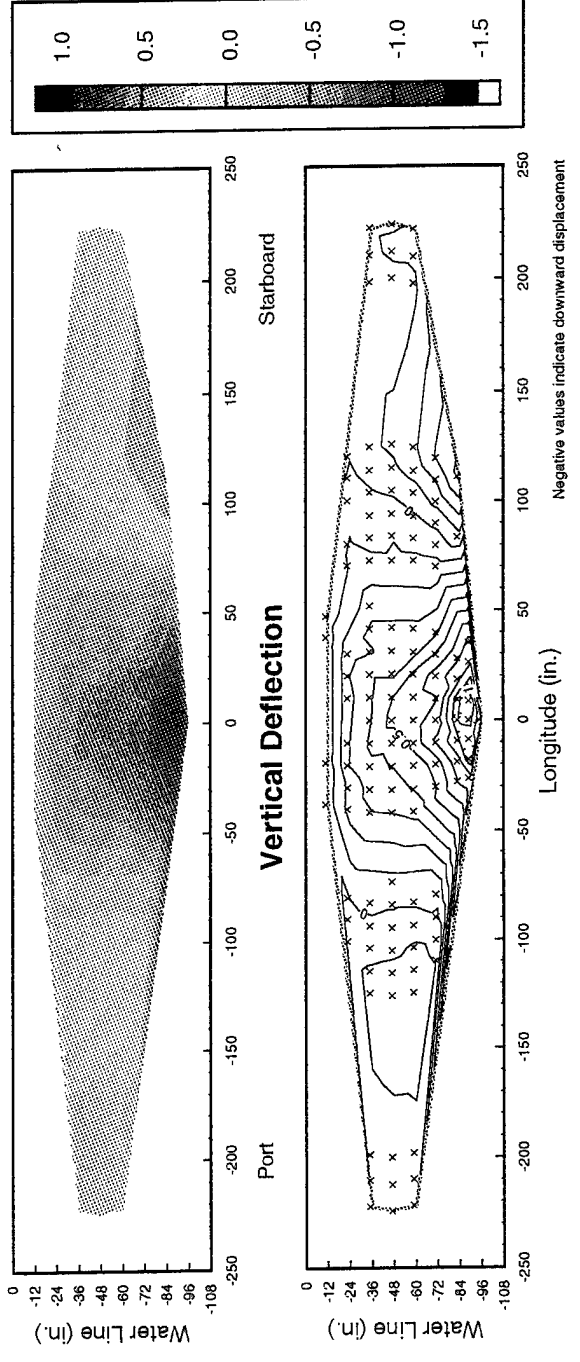
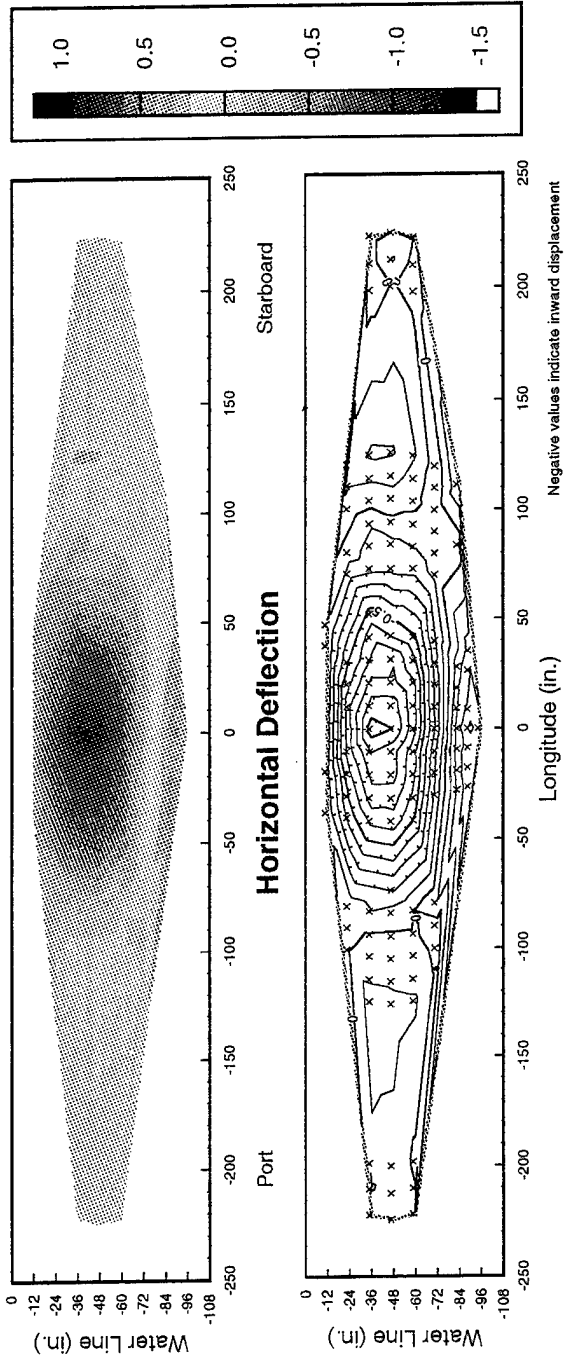

# Data Run: RL23b

Ave. Ship Speed: 23.4 kts    Sea State: 2

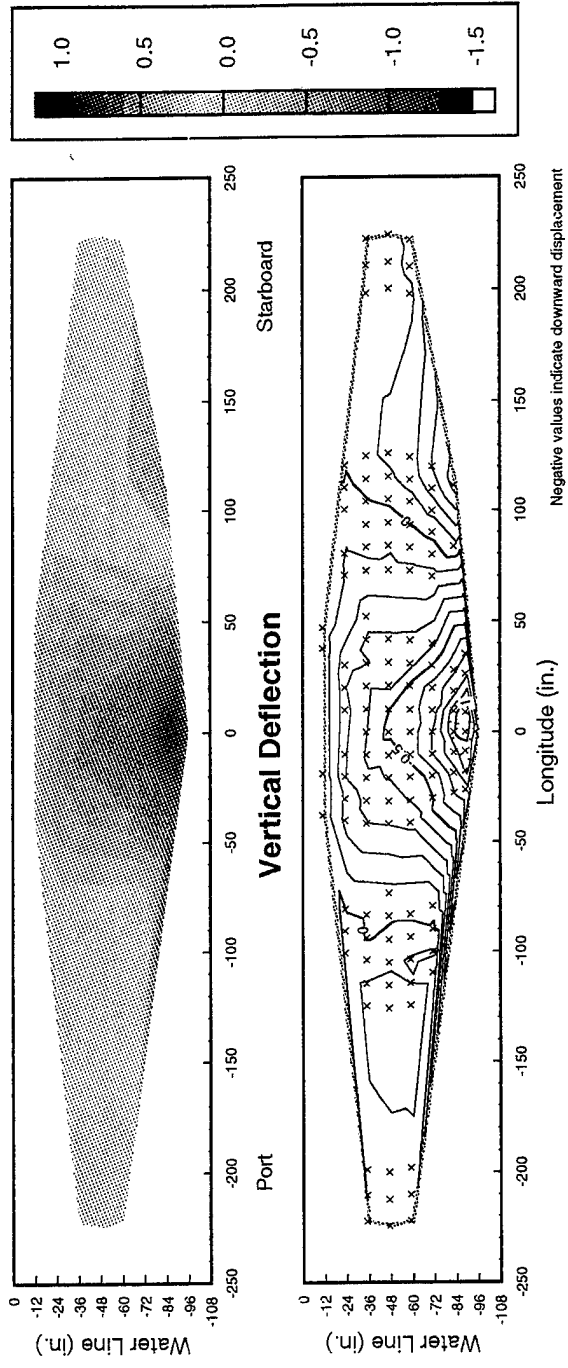
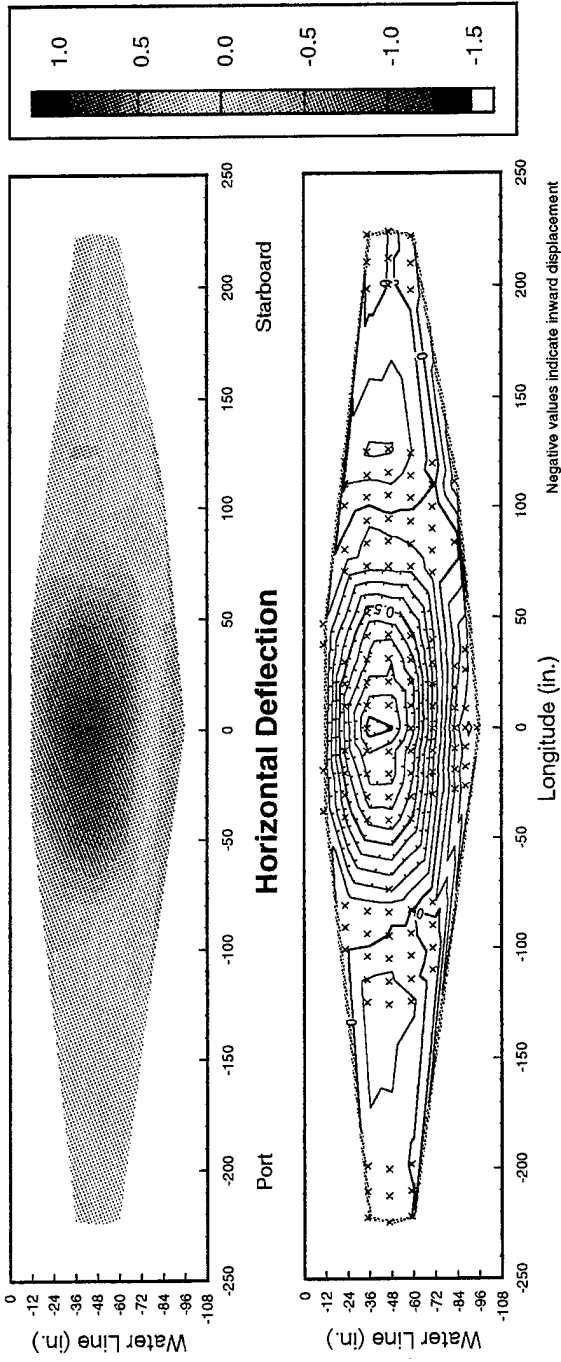



# Data Run: R24a

Ship Speed ~ 24 kts Sea State: 5

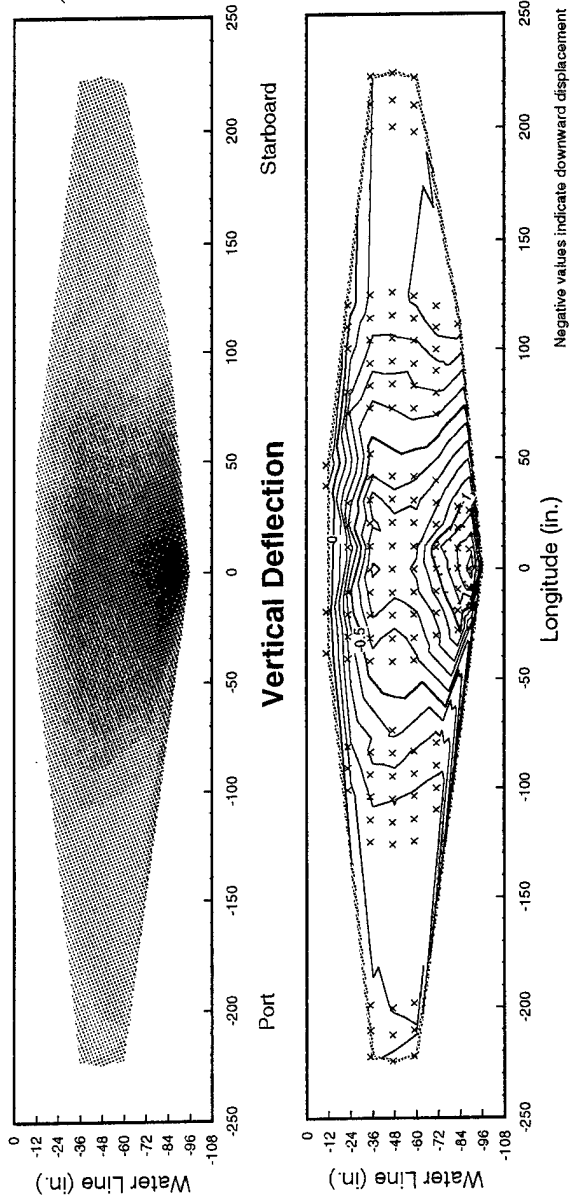
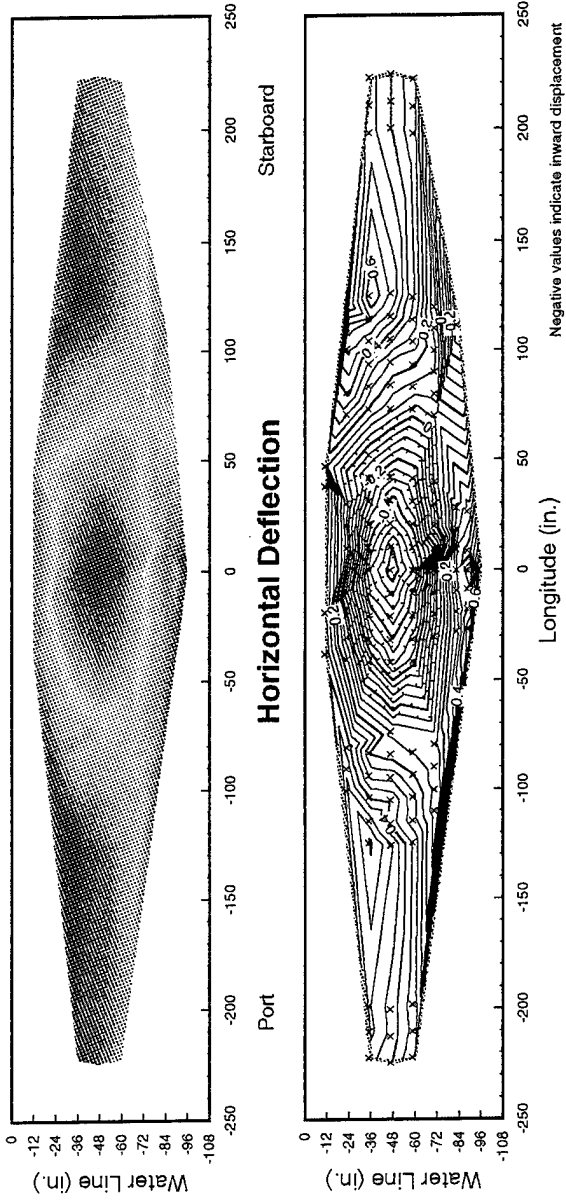

# Data Run: RL25a

Ave. Ship Speed: 25.4 kts    Sea State: 2

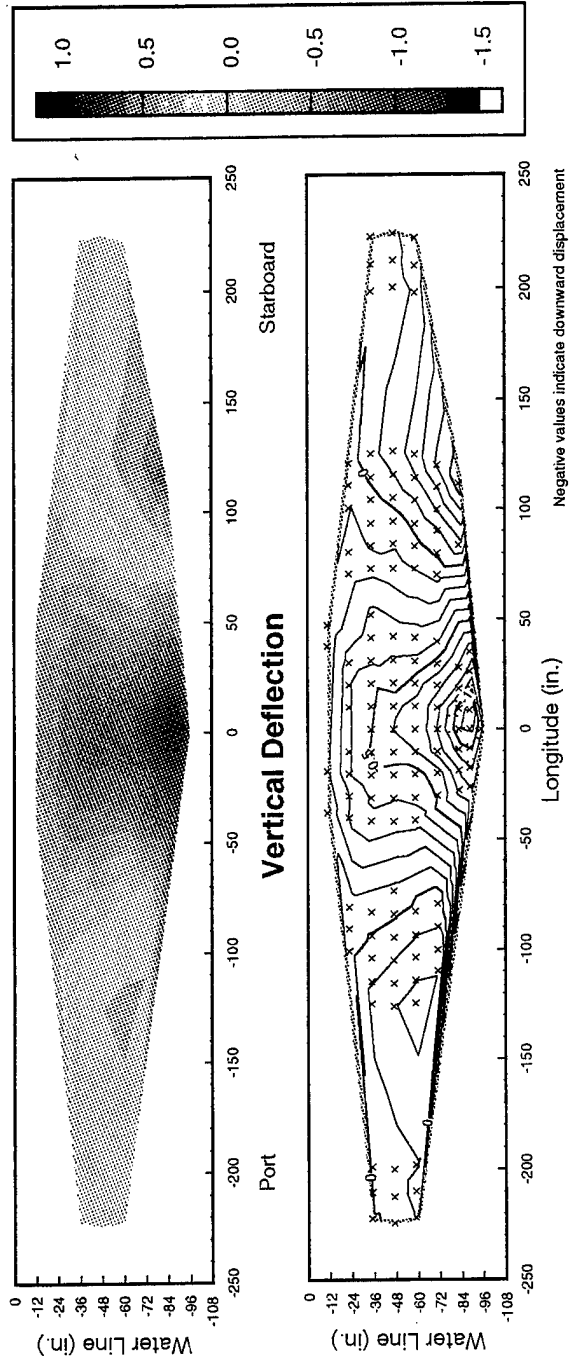
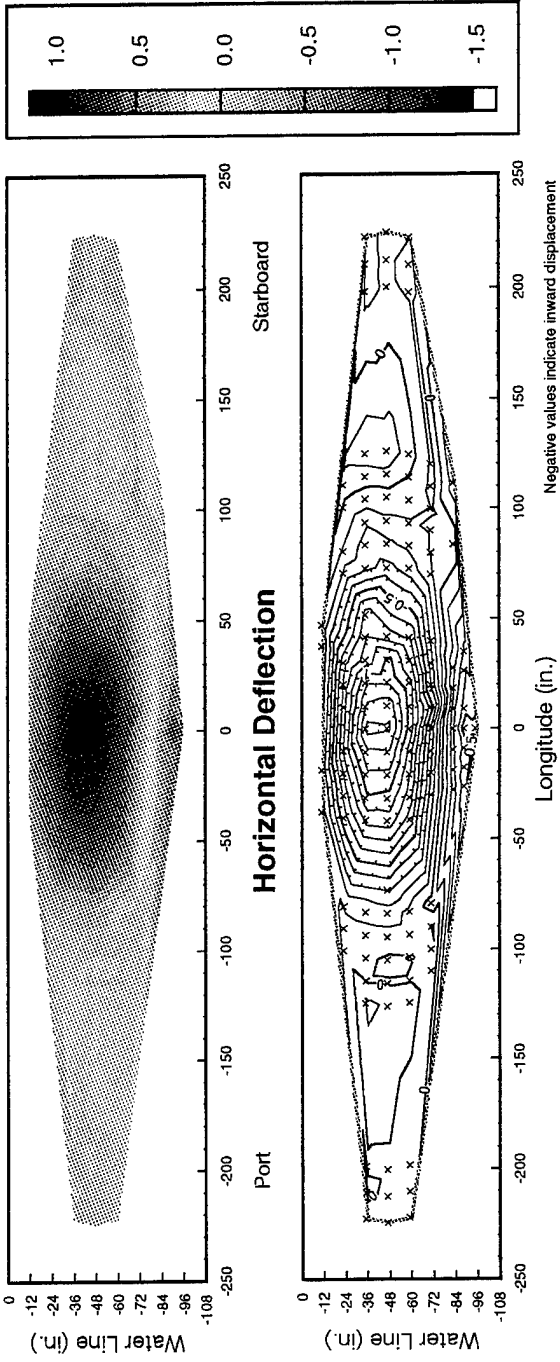

# Data Run: RL26a

Ave. Ship Speed: 25.7 kts Sea State: 2

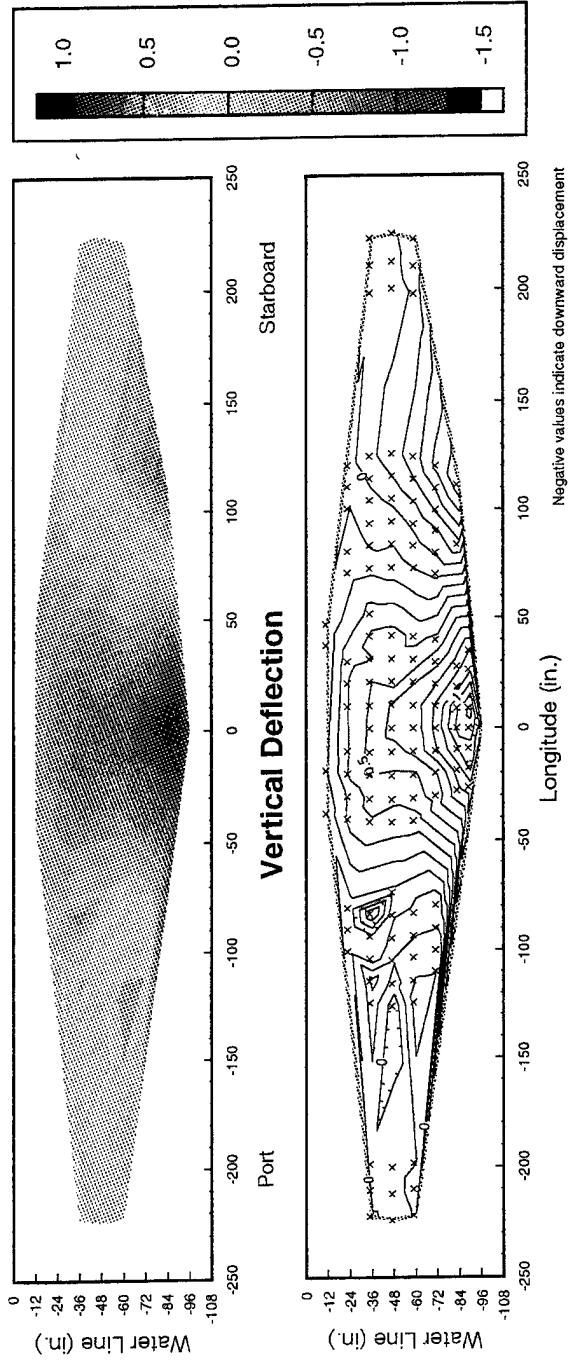
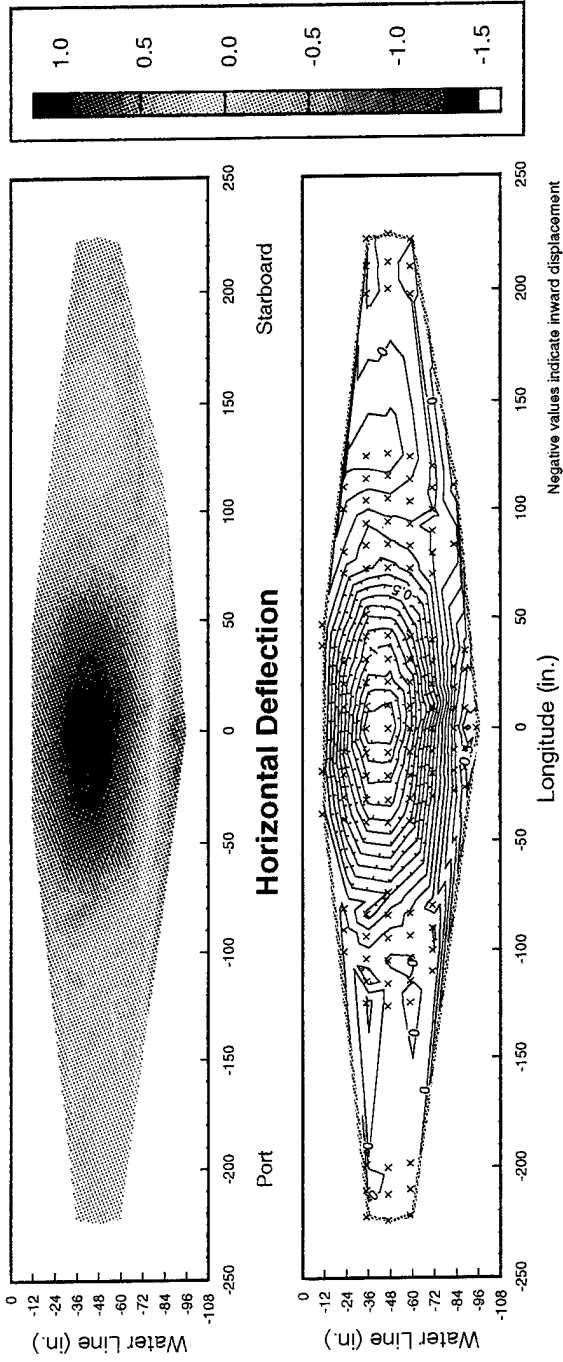

# Data Run: RL26b

Ave. Ship Speed: 25.7 kts Sea State: 2

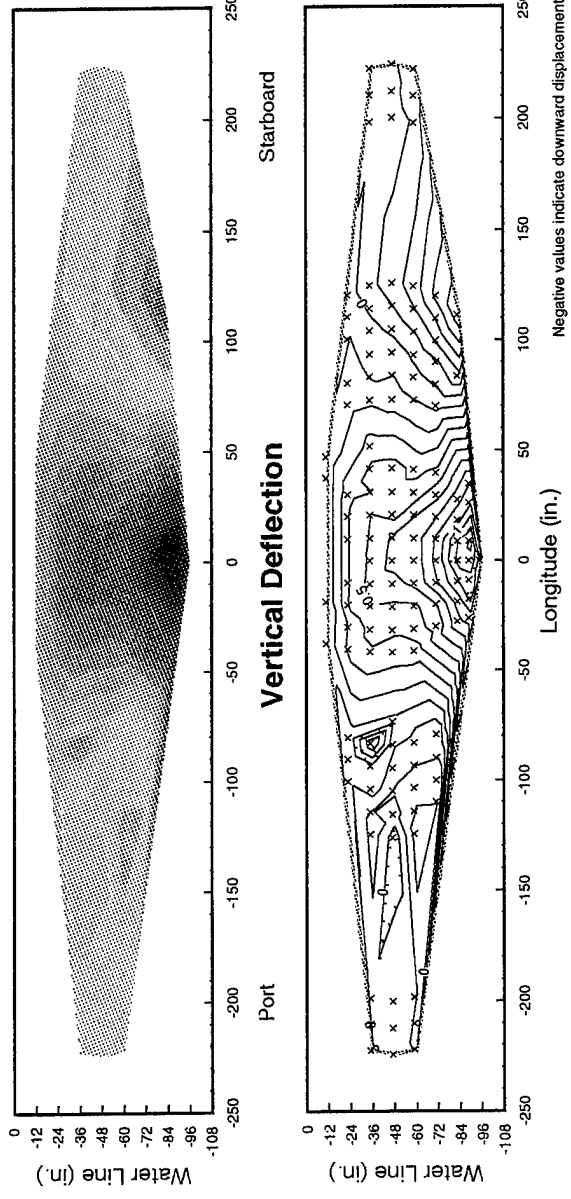
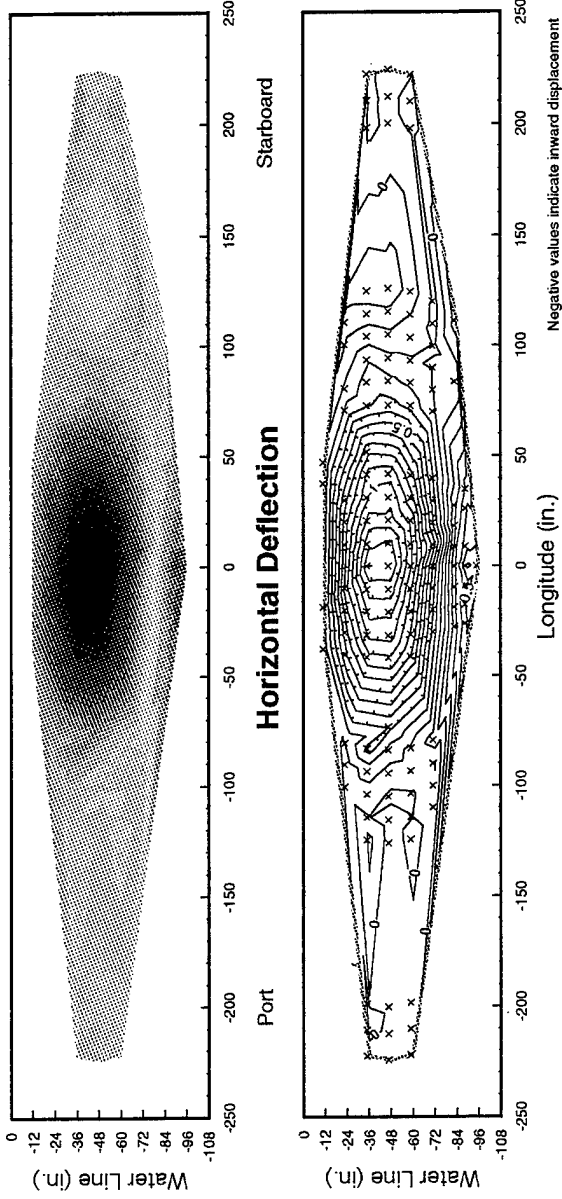

# Data Run: R27A

Ship Speed ~ 27 kts Sea State: 3

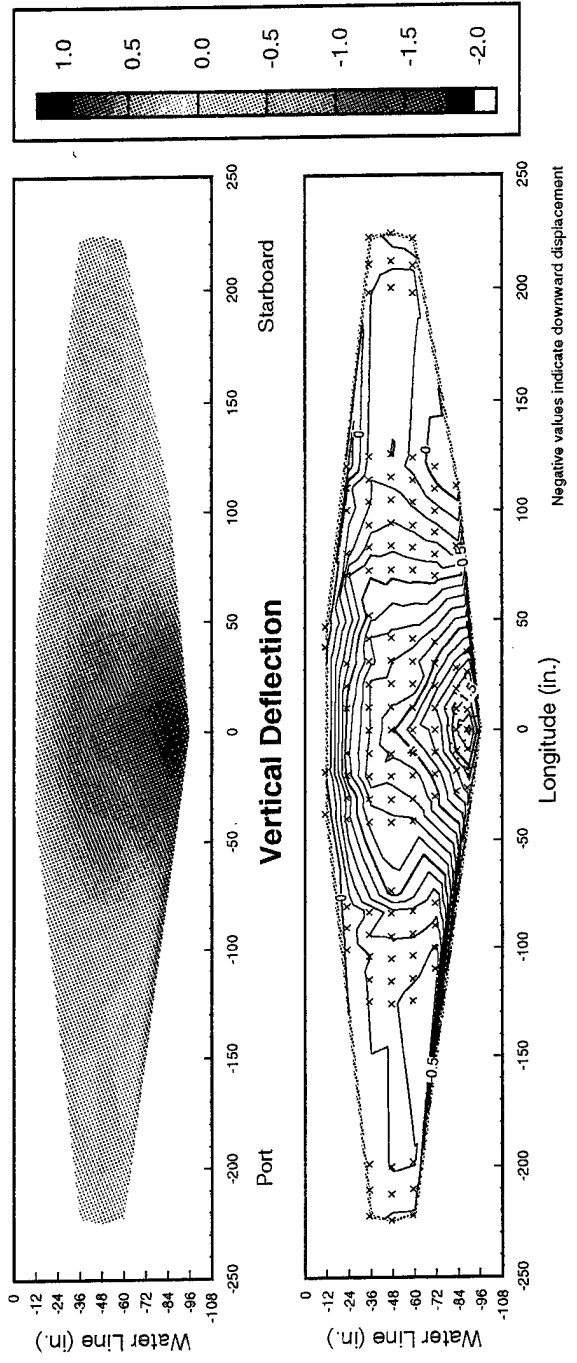
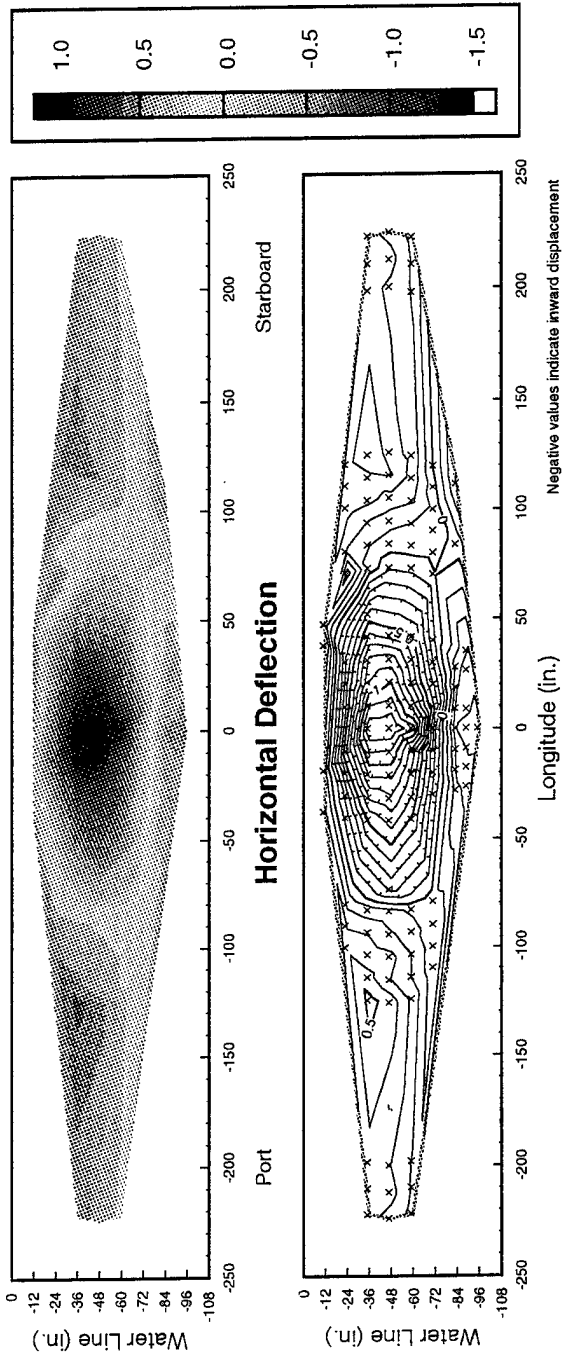

# Data Run: Rq26a

Ave. Ship Speed: 27.4 kts Sea State: 3

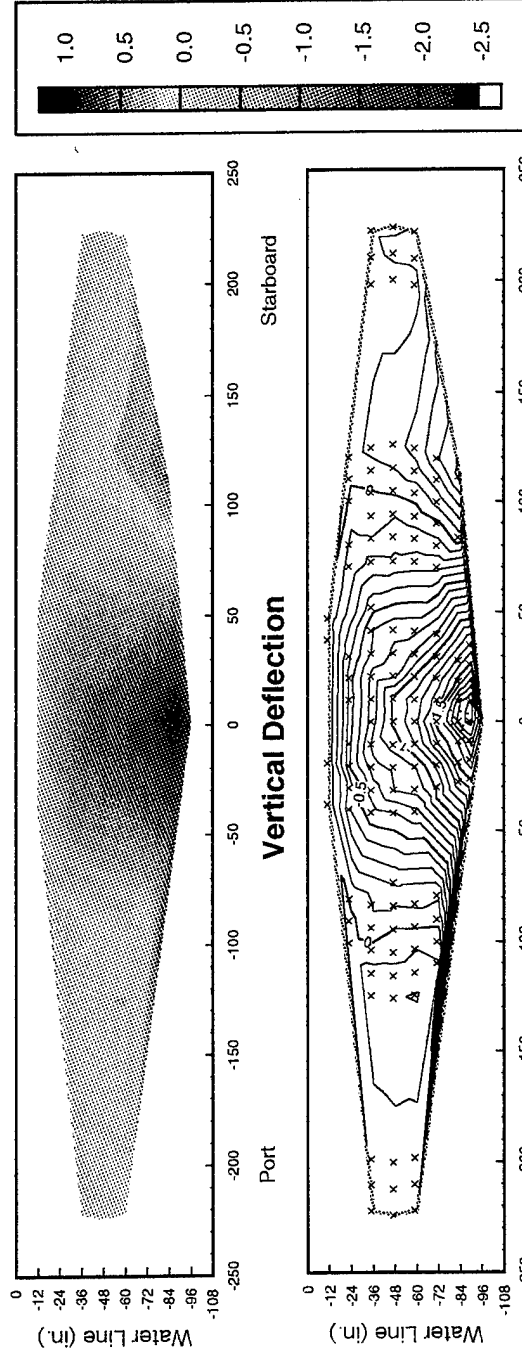
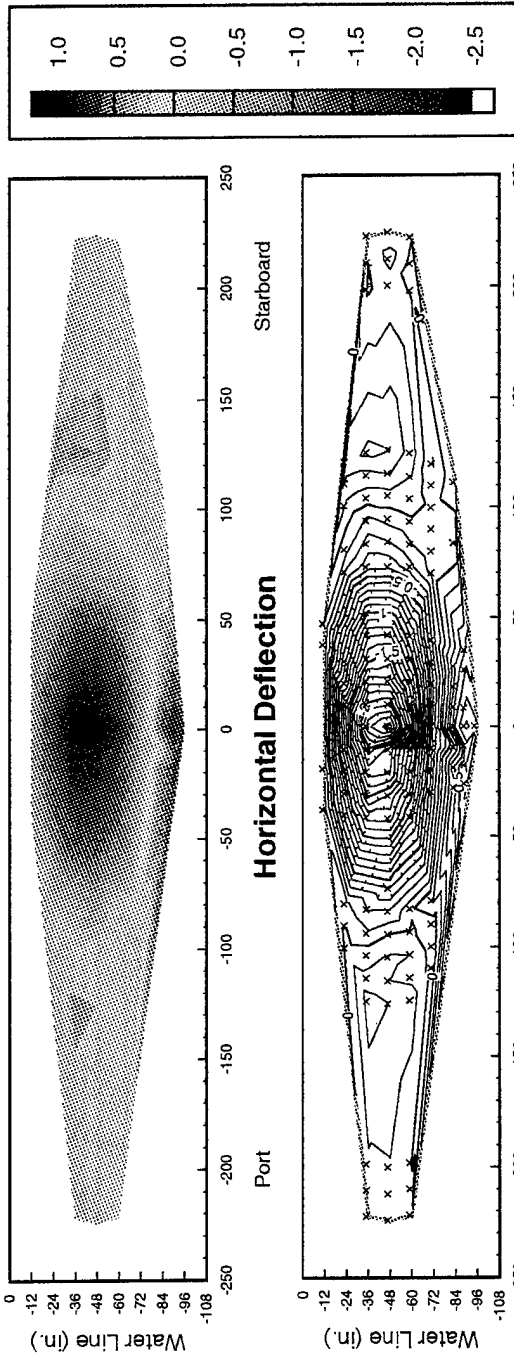

# Data Run: Rq27a

Ave. Ship Speed: 27.7 kts Sea State: 3

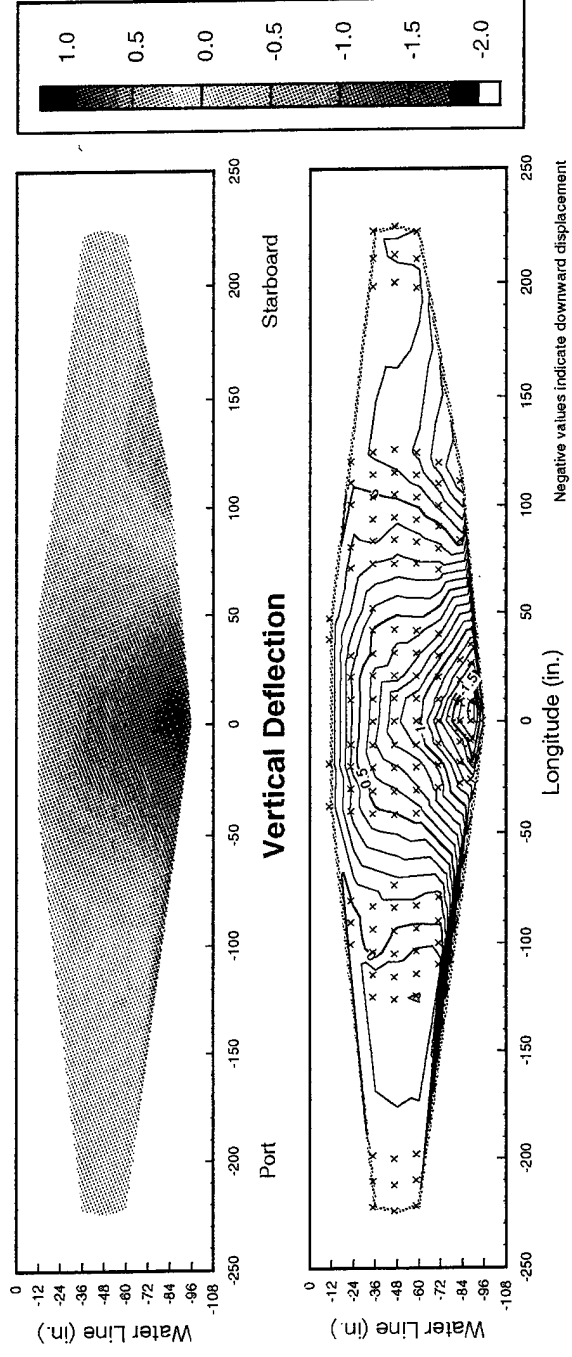
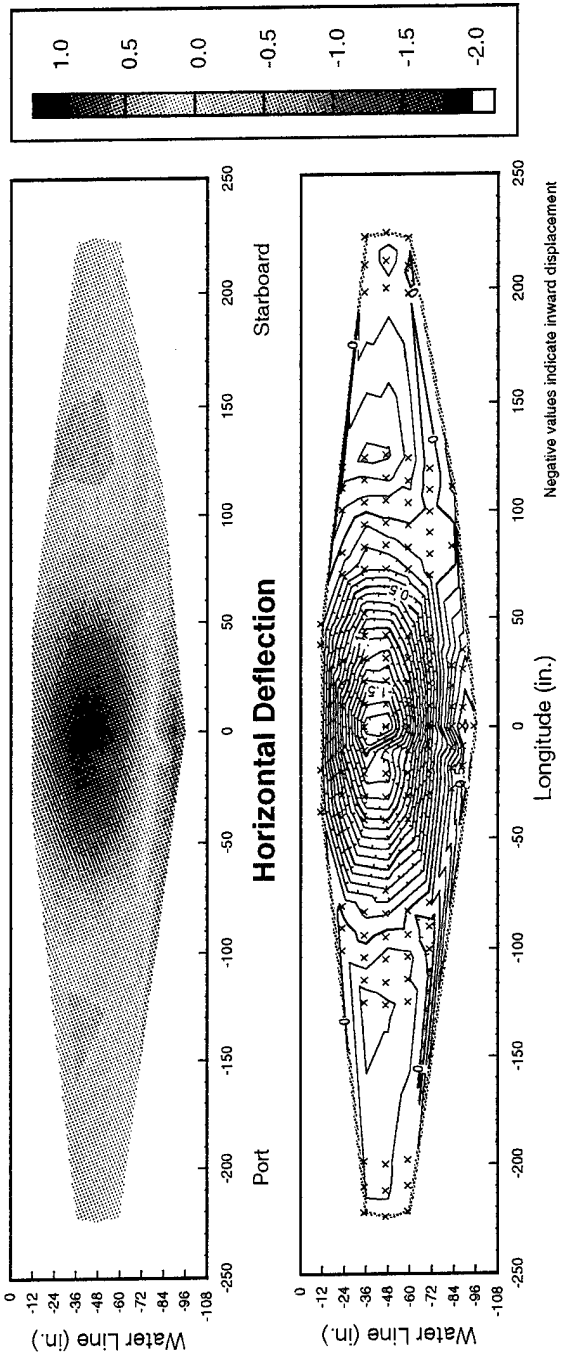

# Data Run: RL28a

Ave. Ship Speed: 27.9 kts Sea State: 2

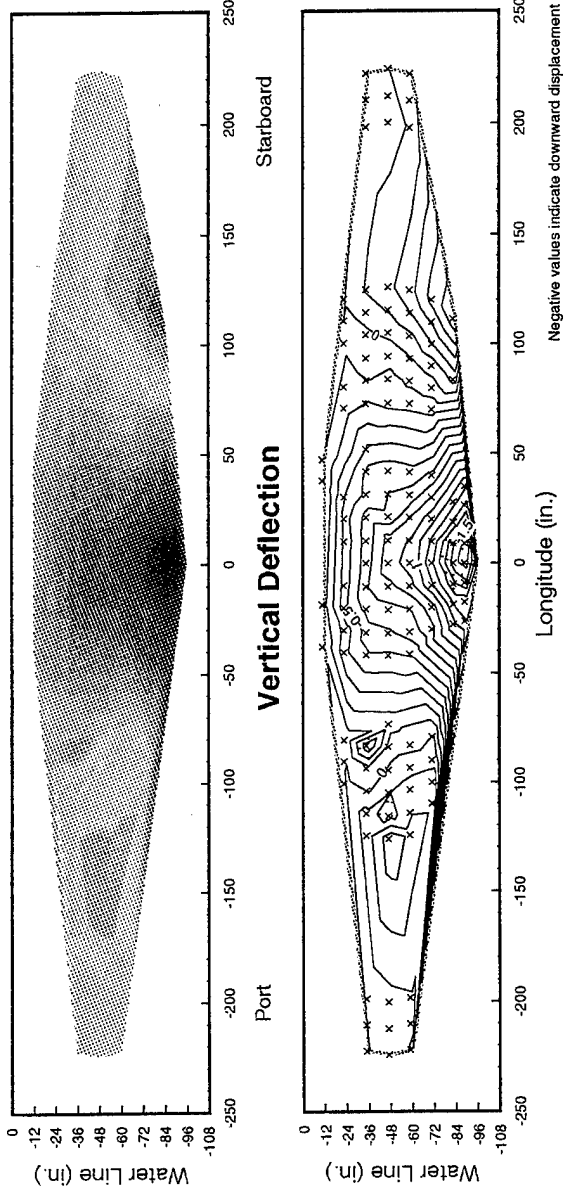
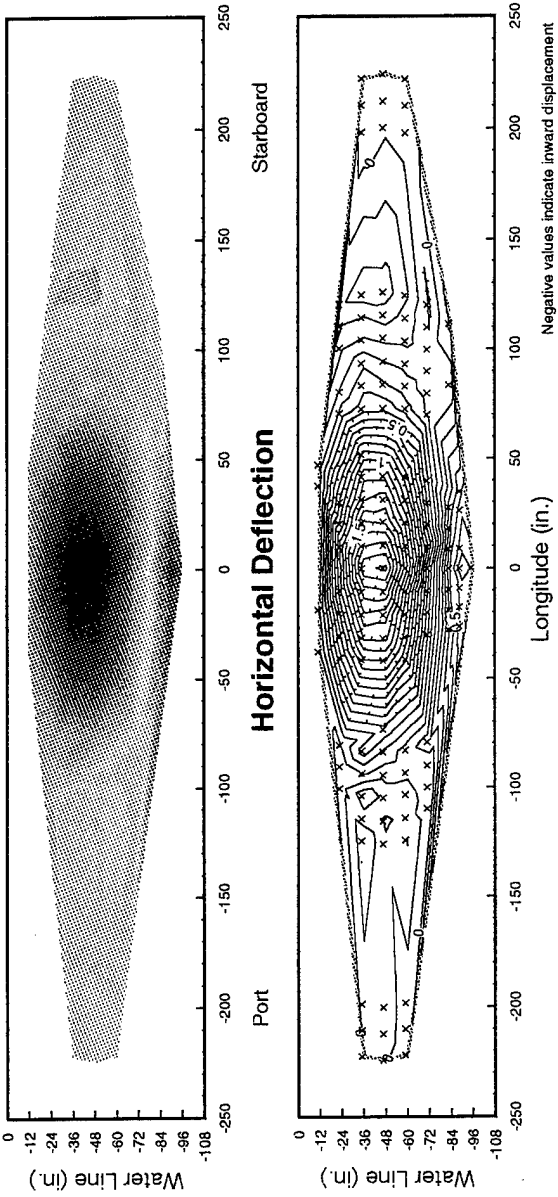



# Data Run: Rq28a

Ave. Ship Speed: 28.5 kts Sea State: 3

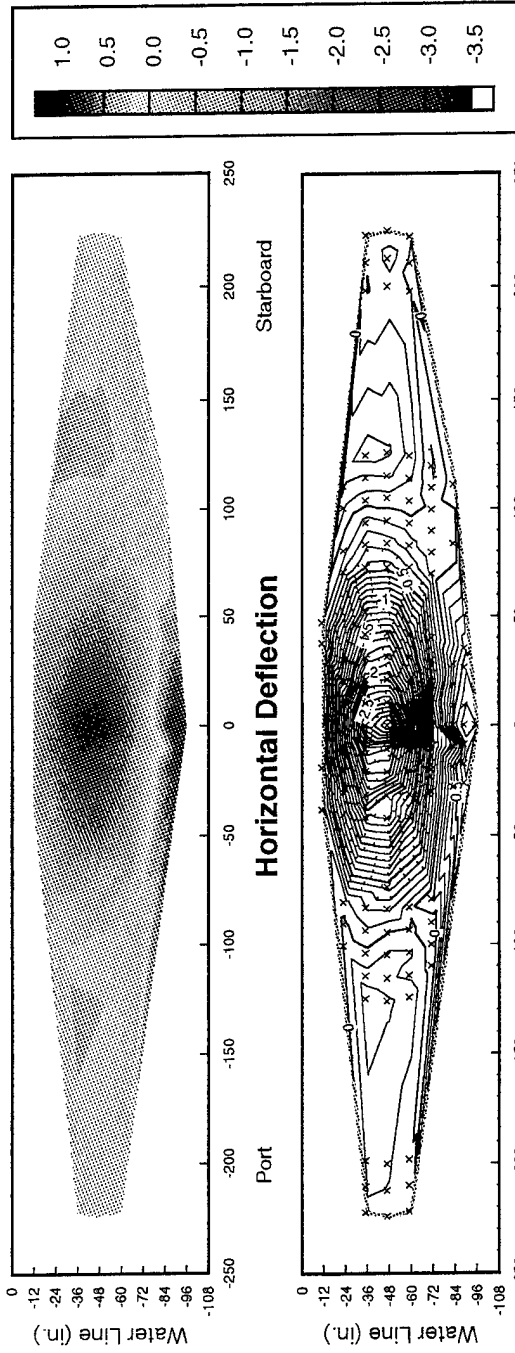

Negative values indicate inward displacement

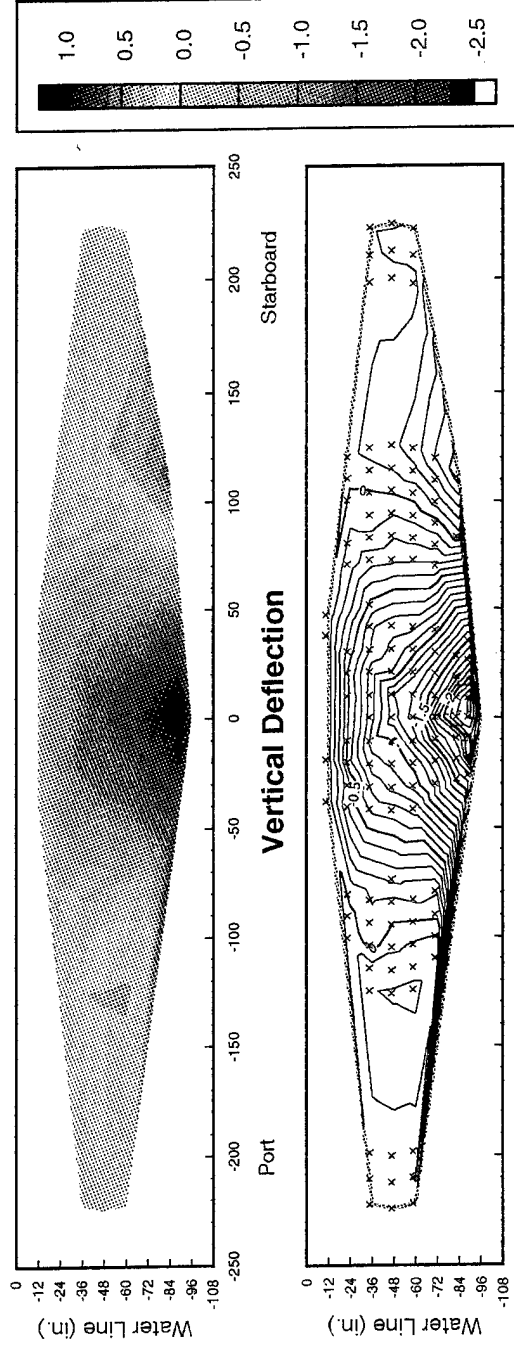

Negative values indicate downward displacement

# Data Run: Rq28c

Ave. Ship Speed: 28.6 kts Sea State: 3

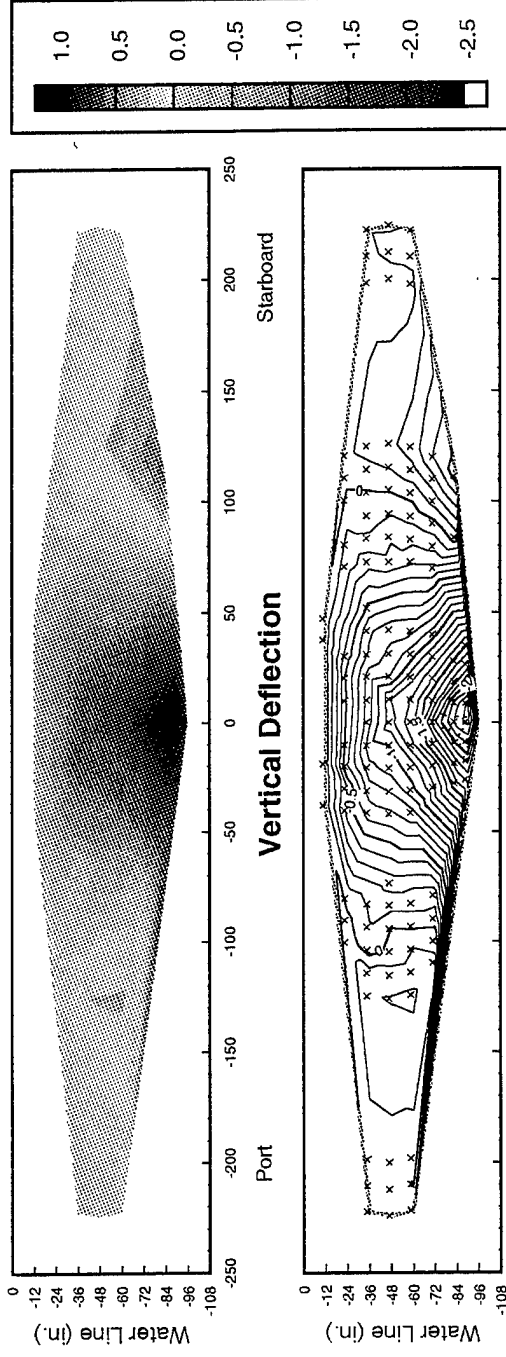
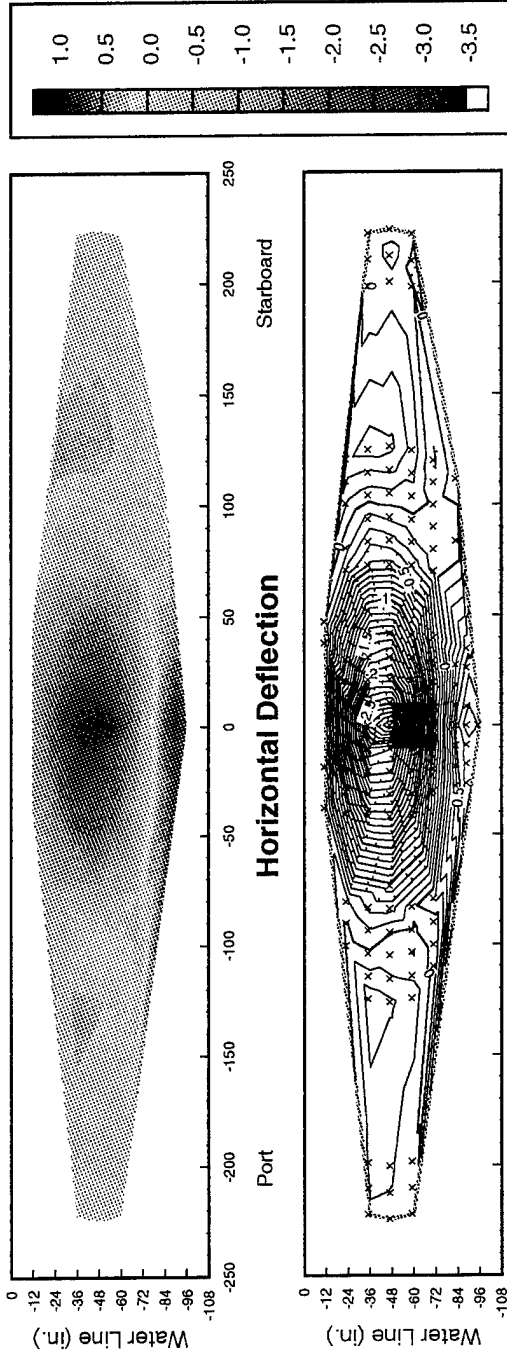

# Data Run: Rq28b

Ave. Ship Speed: 28.7 kts Sea State: 3

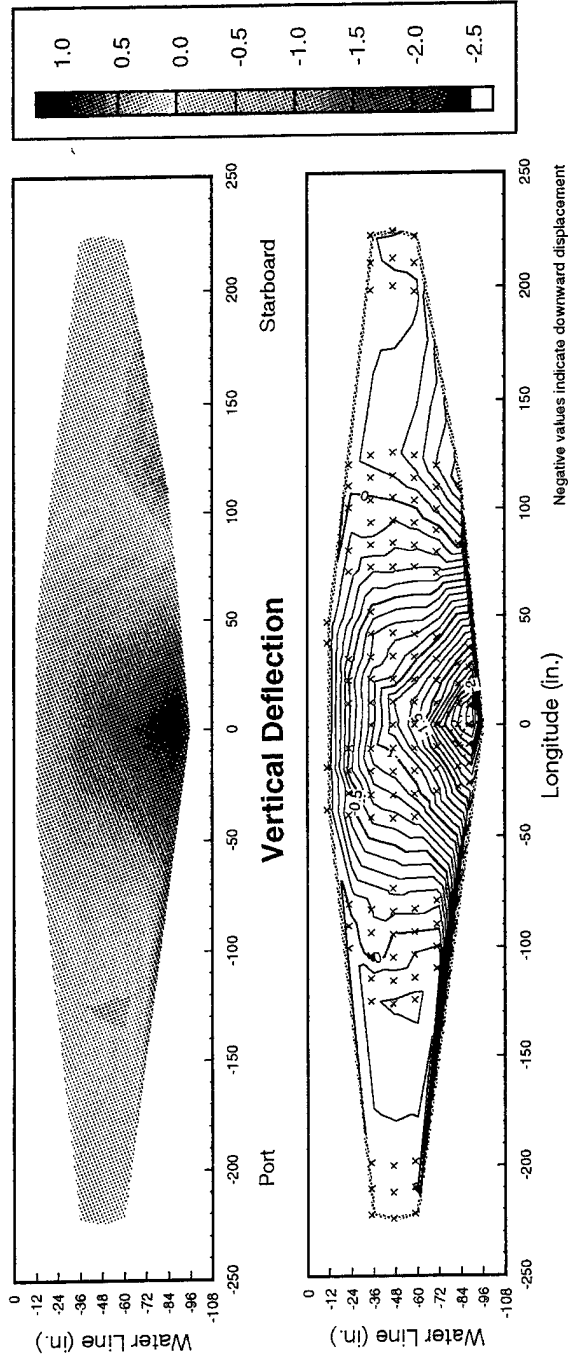
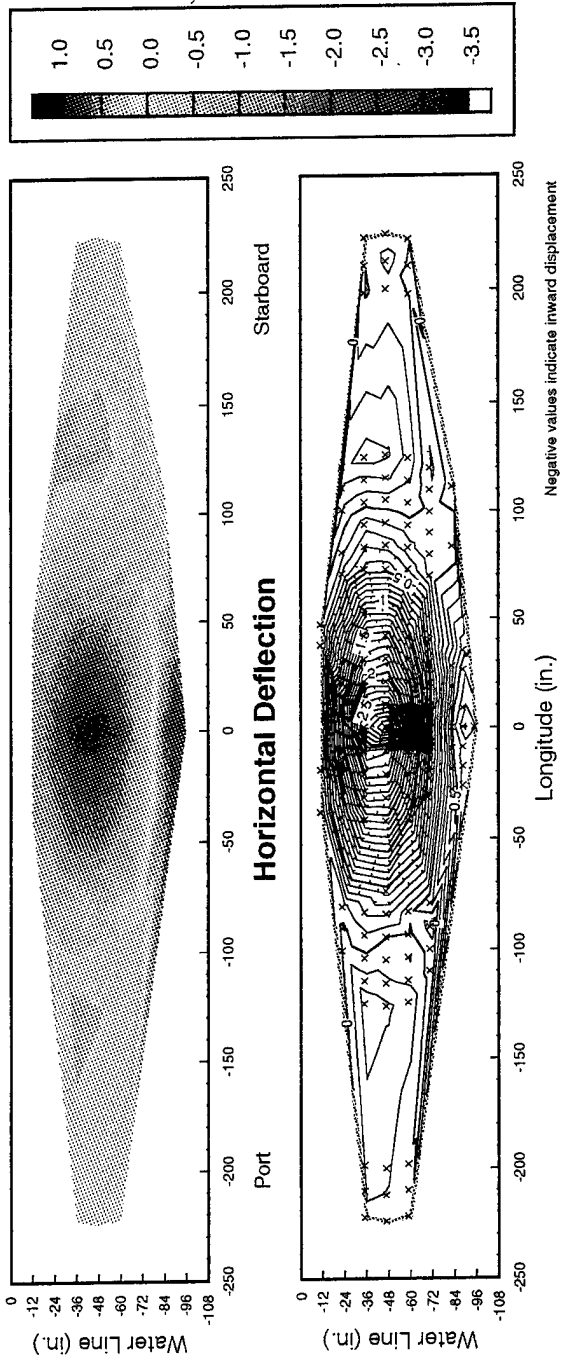

# Data Run: R30A

Ship Speed ~ 30 kts Sea State: 4

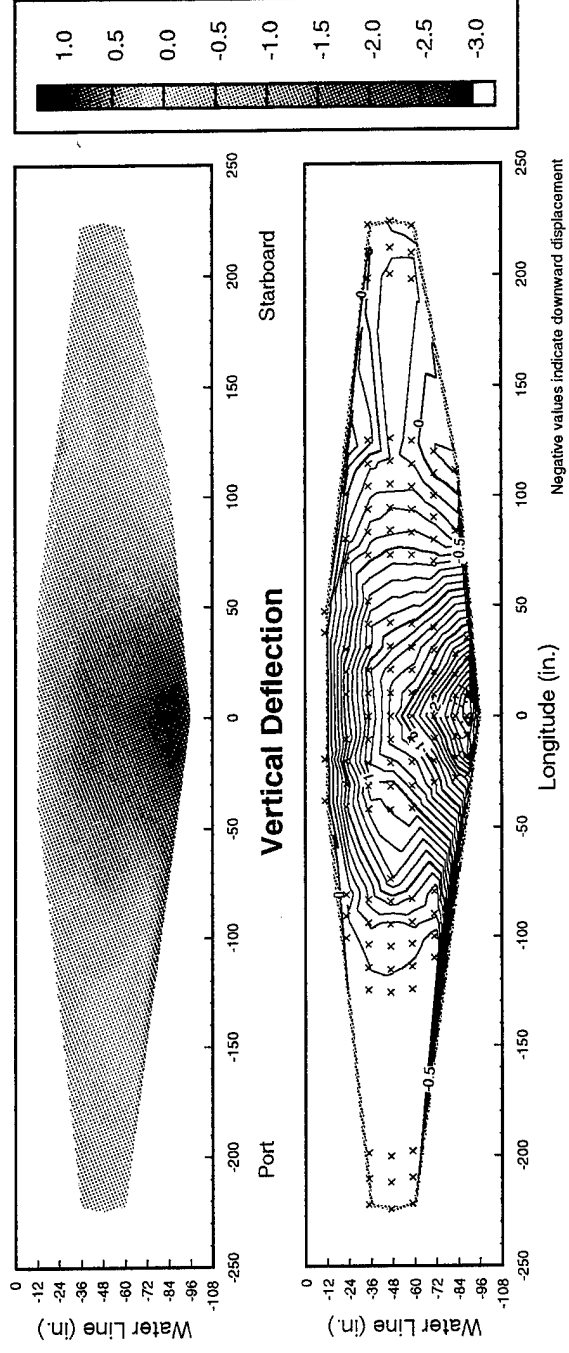
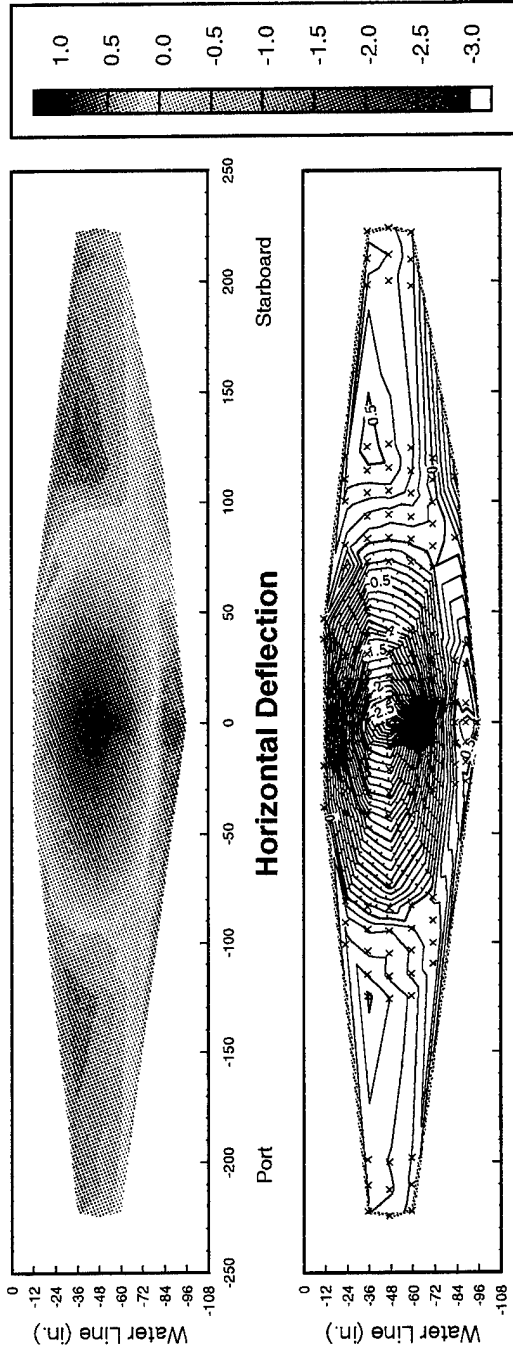

# Data Run: R30B

Ship Speed ~ 31 kts Sea State: 3

