

234156

JPRS-CST-85-021

8 July 1985

China Report

SCIENCE AND TECHNOLOGY

DISTRIBUTION STATEMENT A
Approved for Public Release
Distribution Unlimited

DTIC QUALITY INSURED

T9990414064

FBIS FOREIGN BROADCAST INFORMATION SERVICE

REPRODUCED BY
NATIONAL TECHNICAL
INFORMATION SERVICE
U.S. DEPARTMENT OF COMMERCE
SPRINGFIELD, VA. 22161

1
187
A09

NOTE

JPRS publications contain information primarily from foreign newspapers, periodicals and books, but also from news agency transmissions and broadcasts. Materials from foreign-language sources are translated; those from English-language sources are transcribed or reprinted, with the original phrasing and other characteristics retained.

Headlines, editorial reports, and material enclosed in brackets [] are supplied by JPRS. Processing indicators such as [Text] or [Excerpt] in the first line of each item, or following the last line of a brief, indicate how the original information was processed. Where no processing indicator is given, the information was summarized or extracted.

Unfamiliar names rendered phonetically or transliterated are enclosed in parentheses. Words or names preceded by a question mark and enclosed in parentheses were not clear in the original but have been supplied as appropriate in context. Other unattributed parenthetical notes within the body of an item originate with the source. Times within items are as given by source.

The contents of this publication in no way represent the policies, views or attitudes of the U.S. Government.

PROCUREMENT OF PUBLICATIONS

JPRS publications may be ordered from the National Technical Information Service, Springfield, Virginia 22161. In ordering, it is recommended that the JPRS number, title, date and author, if applicable, of publication be cited.

Current JPRS publications are announced in Government Reports Announcements issued semi-monthly by the National Technical Information Service, and are listed in the Monthly Catalog of U.S. Government Publications issued by the Superintendent of Documents, U.S. Government Printing Office, Washington, D.C. 20402.

Correspondence pertaining to matters other than procurement may be addressed to Joint Publications Research Service, 1000 North Glebe Road, Arlington, Virginia 22201.

4

8 July 1985

CHINA REPORT SCIENCE AND TECHNOLOGY

CONTENTS

NATIONAL DEVELOPMENTS

Change of Ideology Urged To Promote S&T Reforms (Wen Yuankai; KEXUEXUE YU KEXUE JISHU GUANLI, No 12, 12 Dec 84)	1
Workshop on Scientiology, New Technical Revolution Held (Chen Tuguang; KEXUEXUE YU KEXUE JISHU GUANLI, No 12, 12 Dec 84)	8
Psychological Factors on Development of S&T Management Personnel (Wang Jisheng; KEXUEXUE YU KEXUE JISHU GUANLI, No 12, 12 Dec 84)	13
Luo Wei on Relation Between Economy, S&T (Luo Wei; KEXUEXUE YU KEXUE JISHU GUANLI, No 12, 12 Dec 84)	21
Re-Education Aimed at Challenge of New Technical Revolution (Xia Guofan; KEYAN GUANLI, No 1, Jan 85)	28
Plans To Readjust Academic Societies Proposed (Zhao Yingchun; KEYAN GUANLI, No 1, Jan 85)	33
Organization, Management of Marine Acoustic Studies (Han Youquan; KEYAN GUANLI, No 1, Jan 85)	40
Science and Technology Reforms Discussed (Ga Mainan, Zhuo Peirong; LIAOWANG OUTLOOK, No 12, 25 Mar 85)	46
Liaoning Governor on Use of Imported Technology (XINHUA, 5 Jun 85).	51
Importance of Imported Talent Discussed (Yan Jie; ANHUI RIBAO, 27 Mar 85)	52

Applied Technology To Accelerate Economic Growth (Xuan Fenghua; ANHUI RIBAO, 27 Mar 85)	54
Success of Technical Markets Seen in Circulating Commodities (Liu Qinglin; HUBEI RIBAO, 2 Apr 85)	56
Views on Reforming System for Training Doctorates (GUANGMING RIBAO, 5 Apr 85)	59
Apply Economic Lever To Promote Scientific Progress (RENMIN RIBAO, 10 Apr 85)	62
Sichuan Holds Conference on Science, Technology (Sichuan Provincial Service, 26 Apr 85)	65
Anhui's Huang Huang Speaks on S&T Work (ANHUI RIBAO, 16 May 85)	67
Yunnan Vice Governor on Science-Technology Reform (Yunnan Provincial Service, 29 May 85)	69
Wang Fang, Xue Ju Talk With CAS Group (ZHEJIANG RIBAO, 8 Jun 85)	70
Scientific, Technological Association Meeting Opens (Heilongjiang Provincial Service, 12 Jun 85)	71
Scholars Urge Emphasis on Integrated Science (XINHUA, 16 Jun 85)	72
PRC Produces Antarctic Expedition Documentary (XINHUA, 17 Jun 85)	73
Briefs	
PRC-FRG Combined Committee Meets	74
Science, Technology Meeting Concludes	74
Shanghai Science Society	75
Shanghai Cyclotron Remodelling	75

PHYSICAL SCIENCES

Variational Analysis of Phase Transition in Pure Lattice Gauge Fields (Guo Shuohong, et al.; ZHONGSHAN DAXUE XUEBAO, No 4, Nov 84)	76
Quantum Chemistry of Aromatic Nitro Explosives (Xiao Heming, et al.; HUAXUE XUEBAO, No 1, Jan 85)	85

APPLIED SCIENCES

ADRH/XLAT, 8080/Z80 Binary Code Program (Tao Jianyi; WEIXING JISUANJI, No 2, 24 Mar 84)	91
--	----

Pulsed Radiation Detection Technology Discussed (Lu Min; HEDIANZIXUE YU TANCE JISHU, No 6, Nov 84)	99
New Dual Z80 Navigation Computer Described (Yu Shiquan, et al.; DIANZI JISHU, No 1, 12 Jan 85)	113
Superheated Steam's Density Compensation for Flow Measurement (Xu Guanquan; HUAXUE SHIJIE, No 2, 20 Feb 85)	123
Titanium-Nitrogen Ion Beam Injection Studied (Jiang Xingliu, et al.; LANZHOU DAXUE XUEBAO, No 4, 28 Dec 84)	129
High-Power ND: Glass Laser and Target Chamber System and an Experimental Study of Laser Plasma X-Ray (Wu Hongxing, et al.; ZHONGGUO KEXUE JISHU DAXUE XUEBAO, No 1, Mar 85)	132
Titanium Extractant T105-1 Studied (Mu Guangzhao; HUAXUE SHIJIE, No 3, 20 Mar 85)	141
PRC, British Scientists To Explore Tibetan Plateau (XINHUA, 24 May 85)	145
PRC Described as World Leader in Geophysical Surveys (XINHUA, 30 May 85)	146

LIFE SCIENCES

New Law on Pharmaceutical Management Effective 1 July (Chen Guangeng; CHINA DAILY, 14 Jun 85)	147
Briefs	
Shanghai Cancer Research	149
New Drug Management Law	149
Meningitis Cause Discovered	149

ENVIRONMENTAL QUALITY

Role of Environmental Monitoring in Environmental Administration (Sun Jiajin; HUANJING BAOHU, No 3, Mar 85)	150
Understanding of Environmental Laws, Management of Environment (Luo Dianrong; HUANJING BAOHU, No 3, Mar 85)	156
State Council Determines Environmental Tasks for 1985 (ZHONGGUO HUANJING BAO, 13 Apr 85)	159
Work Plan Outlined	159
Qu Geping Discusses Work Plan	160

Guangzhou's Antipollution Campaign Pays Off (XINHUA, 6 Jun 85)	166
Liaoning Success in Pollution Control Noted (XINHUA, 12 Jun 85)	167
Thermal Power Plants Reduce Pollution (XINHUA, 13 Jun 85)	168
Briefs	
Environmental Protection Exhibit Closes	170
Qaidam Basin Salt Lakes	170
Nei Monggol Underground Lakes	170
Frequency of Acid Rain Increases	171

ABSTRACTS

SILICATES

GUISUANYAN XUEBAO [<u>JOURNAL OF THE CHINESE SILICATE SOCIETY</u>], No 4, Dec 84	172
---	-----

NATIONAL DEVELOPMENTS

CHANGE OF IDEOLOGY URGED TO PROMOTE S&T REFORMS

Tianjin KEXUEXUE YU KEXUE JISHU GUANLI [SCIENTIOLOGY AND MANAGEMENT OF SCIENCE AND TECHNOLOGY] in Chinese No 12 12 Dec 84 pp 10-12

[Article by Wen Yuankai [3306 0337 0418], Chinese Science and Technology University]

[Text] At the 3rd Plenary Session of the 11th Party Central Committee, it was pointed out: "To achieve the four modernizations, and to look for a large scale increase in productive forces, we must seek to change the relations of production and of the superstructure which are not adjusted to the development of productive forces. We should also change any inappropriate management, activity and ideological patterns. Therefore, this is an extensive as well as intensive revolution." Six years of practice proves that this is a truth.

Social development and conceptual changes are closely related. Concepts must be suited to systematic reform in order to have consciousness bring its positive initiative into full play.

For a long time, China has been an agricultural country, and is now progressing from an agricultural society to an industrial one. We must not only absorb the civilization and concepts of the third wave, but must also absorb some of the civilization and concepts of the second wave (industrial and technological revolution) which are still useful to us. Especially conceptual problems, only when they have undergone fundamental change can they adjust to the development of the society.

For example: Time Concept. We must set up the concept of time is money and life. We should value our time, work rapidly and intensely and deal with things with a sense of imminence. In order to enliven our economy, to gear it to the world, and to take the arena of international economy as a battlefield, we should stress the time concept even more. Looking at the current situation, our time concept is extremely poor: documents and meetings dominate everywhere; the effectiveness of information delivery is not paid attention to; a large amount of the cadres' time is immersed in fruitless labor; the cadres always discuss matter which should be handled by the authorities of subordinate departments over and over again and end up too tired to take care of large projects; moreover, the cadres always run a meeting for many days or even tens of days and during the meeting there are often breaks for movies, sightseeing

and shopping; the cadres always spend half a day in a meeting for things which can be solved in 5 minutes with a phone call or a note. In any case, time is the most worthless thing in our country. It does not show its ever-increasing value in social development.

Efficiency Concept. Efficiency is life. The most serious problem we have in our economic system as a whole is not quantity but quality and the efficiency of management, particularly the quality of managers; the out-of-date pyramidal structure which directly conditions the efficiency problem. Whether we can pay a lot of attention to efficiency has an immediate relationship to our success or failure in the four modernizations. We should stress efficiency and let people who fail to do a good job be responsible for it. If incompetent people are not used, there will not be unnecessary meetings and excessive personnel.

Credit Concept. Credit and efficiency are directly related to each other. The credit of a country is related to the stability and continuity of her long- and short-term policies. In the past, our changeable policies caused the broad masses to lose faith and security, and feel helpless about the future. However, with the agricultural policies which have been set for the next 30 years and Hong Kong policies for the next 50 years, the masses' faith in our policies has greatly increased. The credit of enterprises is even more important. It is their foundation. Today when the economy is open and international trade is stressed, we should pay more attention to our credit. It is something people internationally are very particular about in foreign trade. It is something which will have great influence in our further opening up of the international market and expansion of management scale. Meanwhile, credit is also very important in people's relationships. Only when everybody can keep his words solemnly can a more efficient and better coordinated social relationship be established.

Competition Concept. Is competition exactly good or bad? Is it capitalist? We have recklessly criticized these questions for 30 years and paid a terrible price. Today, we finally understand that competition is good because it brings forth vitality and progress; that the equalitarian non-competition and the "big rice pot" policies in the past have given us a hard time. The competition we are advocating is different from that of capitalist society where the weak are the prey of the strong and people fight with each other severely. In a capitalist society, the strong own millions of dollars and the poor lead a miserable life. We should encourage the strong and promote and support the poor at the same time. We will not advocate equal poverty by "stealing from the rich to help the poor." Rather, we encourage some people to get rich first and then gradually guide the whole people to the road of wealth by hardworking thereupon achieving equal wealth.

Value Concept. As the society develops, people's value concepts change, too. Currently, there are some individual as well as specialized households which have obtained their economic status by hardwork. However, their social status remains about the same. To some people, especially to some intellectuals and young people, these households are unorthodox, even questionable. This, in fact, is the result of long-term feudalism. In the past, the hierarchy was always: officials, farmers, workers and merchants. Economy-related jobs have

always been despised. Personally I admire comrade Jiang Zilong's [5592 1311 7893] works "The Symphony of Pots, Bowls, Laddles and Basins" in which he depicts the story of the manager of a small restaurant. In the past, who cared to write about this kind of people? We should see that managers are what we need most urgently in our current economic development. They are no less than the heroes of today. We should continue to smash the residues of feudalistic ideological thinking that studying is the noblest thing on earth and that when one excels in scholarship, he can serve as an official and that the elders are honorable. We should encourage some youth, staff and workers, cadres and scientists and technologists to work to become entrepreneurs, thereby enabling our economy and other business to develop better and faster.

In the civilization of the third wave we should modernize our concepts. Among the concepts to which we should pay special attention to is information. We should fully understand the value of information, of talents and of knowledge.

I. The Value of Information

I admire the "How Much Is An Idea Worth" column in "Economic Reference News" very much. An "Idea" derives from information. Once it is properly used in economic construction, it will immediately become wealth and yield economic and social benefits beyond estimation. The new technical revolution is the first to feel the impact of information processing techniques based on the micro-computer. As can be seen, information is very important to economic and social life. How is the value of information realized? Let me explain it with the following two stories.

At the end of 1982 when the news about our chemistry teaching and research laboratories being designated as a reform experiment network was released, one factory in Hunan facing bankruptcy sent us a telegram, happy at an unanticipated opportunity, immediately asking for technical information. Along with the telegram, they sent us by telegraphic transmission 100 yuan for the service. The story was that this factory was planning to manufacture a new product but could not find a place to look for the technical materials, market and scientific and technological information they need. I assigned a teacher who spent 1 - 2 days looking up information about relevant foreign patents and sent a copy to the factory after duplicating it. The factory was thus saved. In their letter to us, they thanked us and asked to pay an additional service fee.

In the eve of the spring festival, I happened to meet a young man in Hefei who wanted to become an entrepreneur. The young man used to work in a bakery and was not competitive at all. I told him that lysine was a kind of amino acid which our body needed but could not synthesize itself. It could only be obtained through food. In Japan, snacks of lysine-enriched bread for primary and middle school students are required by law and are provided free to the students. In recent years, the average height of Japanese has increased by about 10 mm. The lysine-enriched bread has a lot to do with that. Nowadays, people's living conditions are getting better and better. They not only want to have enough to eat, but the food has to be good and nutritious. Today Hefei still

does not have any lysine-enriched bread and so if he started to make them it would sell very well. The young man was fascinated with what I told him and asked me right away to look up and copy relevant foreign information for him. In a few days, lysine-enriched bread was on the market and, as was expected, sold very well. Even though thousands of loaves were made every day, there was still not enough.

Information like that above is very common in universities and scientific and research institutes. Information is useless printed in books and journals or even in one's mind; but once it gets to the hands of an entrepreneur, it becomes wealth and yields a lot of economic and social benefits. Therefore, it is not improper to say that information is money and wealth.

II. The Value of Talents

Information is money. How, then, do entrepreneurs obtain information? I will answer this question with an example.

When I studied in France, my advisor, Professor Borman was a first-class master in the international academic field. He was also consultant to many big companies. The way the professors held their part-time job was very special. On Saturday afternoon, the president of one of the companies he worked for would call up and invite him to have dinner at a very good local restaurant. The professor would go to the restaurant he was invited to and then the two of them would eat and chat along. The topics were broad, including everything under the sun. The president just mentioned a few questions which he was concerned about and asked the professor's advice. When the supper was over, each went his own way. At the beginning I was very puzzled. Does the president spend a few thousand dollars a month to hire the professor just to ask him to have dinner with him? Finally I understood that it was their working dinner. It was during those eating and chatting that the president obtained the latest information. The inspiration he got from the information was very important to his business. Therefore, it was worth it for him to pay a few thousand dollars to hire the consultant. In foreign countries, part-time jobs like this one are very common. Gerald Ford, the former president of the United States, was consultant to over 10 big companies, making about 1 million dollars a year. Besides hiring people part-time, sometimes the president of a big company, in an effort to get talent, will spend a lot of money trying to get talent from another company. If he can not get the talent he wants, he would buy that small company whole and thus get the talent too. Talent is considered a very important capital in foreign countries.

In the office of the general commander of the Shekou Industrial Area, Shenzhen, there are two slogans which are: "Time is money, efficiency is life." We think that they are very interesting and commendable. These slogans, in fact, have been used in foreign countries for decades. Confronted with the challenge of the new technical revolution, we should further understand that information and talent are even more important. Thus, we can bring forward two slogans which suit the current situation even better: "Ideas are wealth, talent is capital."

I also advocate that we should let talent show its value through mobilization.

There are many reasons which affect the proper reflection of the value of our talents. Of these, I believe that the departmental ownership system in our personnel system are two important factors causing the stagnant situation. Of the reform experiment plans for our chemistry teaching a research labs, there is a major one which proposes to try out an appointment system, carry out talent mobilization and allowing unrestricted dismissal and resignation. It also encourages teachers and staff and workers, on the premise that they complete their assignment, work or teach part time in industrial departments or be their technical consultants. By so doing, the water will not be stagnant any-more and the value of talents will be shown automatically.

Anqing City was very short of scientists and technologists. In the entire city (including the head plant of Anqing Petro-chemical), there were only 1,000 people who held technician or higher positions. Since my position there as scientific and technological consultant to the Anqing People's Government and director of Anqing Chemical Engineering Institute, I suggested that they break with convention and started advertising for talent. They accepted my suggestion and placed their advertisement for scientists and technologists in "Economic Reference", GUANGMING RIBAO and WENHUI BAO. As I had expected, within 20 days they received over 570 applications from over 500 scientists and technologists for engineering, lecturing and higher positions. In the past, it was believed that talent mobilization would cause talents to concentrate in big cities. However, Anqing City's job advertisement proved this was not true. Of the over 400 applicants, tens of them were from Tianjin, Nanjing, Shanghai, Beijing and big cities such as Shenyang, Xi'an, etc. This is because they could not find their place in those cities and that their working conditions needed improvement. A deputy chief engineer from Shanghai applied to "contribute to the four modernizations" on the condition that his daughter-in-law who is working at a collectively-own enterprise be transferred to one owned by the whole people. One deputy technical director from a big research institute in Shenyang applied for the job just to "improve his current housing conditions." Anqing City is vigorously preparing and creating conditions in order to get as many talents as it can and does its bit for the development of the local economy. Looking at the present situation, it is an effective method for units and regions where talents are in short supply to invite applications for vacancies from outside. It promotes the circulation of talent and the carrying out of reform and policies concerning intellectuals. Therefore, units and regions which need talents should treasure this great opportunity and "eat" a large sum of talents who, in no time, will become important capital leading to economic development. Otherwise, when time lapses the talent will also have a "price increase."

III. Knowledge Should Appreciate

In our country, a social atmosphere where there is respect for knowledge, for intellectuals and for talents has yet to be achieved. The main reason is that people are still not quite clear or still have not known enough about the idea that knowledge is wealth.

In 1981, I gave a report on my latest scientific research achievements at Curie University, France at an international scientific conference. Everybody was amazed. Then and there, a lot of experts and professors invited me to give lectures. Professor Thomas [ta ma si] of the famous Pisa University, Italy invited me to give lectures in his university and paid me 260,000 Italian lira (about US\$200). I went to the university at the scheduled time, gave a 50-minute lecture and answered questions for 10 minutes. Altogether it took me only 1 hour. When the lecture was over, I asked Professor Thomas: "I only gave an hour's report and you paid me US\$200. You are too kind!" He replied: "It is worth it. After listening to your report, my researchers, instead of starting from the very beginning, can start doing new research work. Is it not worth it?" He added: "If it had been a more famous scholar and not a young one like you, I would have had to pay from US\$500 - 1,000 for that hour!"

The reason that I mentioned this story is not to stress that we should also pay professors US\$200 an hour. It is beyond our measures at the present time. What I want to stress is that if we want to carry out modernization, we should establish modern concepts concerning the labor of intellectuals: a higher value should be placed on knowledge. Placing a higher value on knowledge is closely related to the realization of the value of talents.

Aside from those mentioned above, the modernization of concepts covers many aspects. One of the important ones is to smash the concept of "officials, peasants, workers and merchants" hierarchy.

The position of commerce has never been considered very high in our country. In the "officials, peasants, workers and merchants" hierarchy, merchants rank "the last of four occupations." As soon as you mention money, people think you are not elegant and despise you as having "merchants' habit." When people talk about talents, they mean scientists, writers and the like. Entrepreneurs are not considered among them. In fact, the talent that we need most at the present time are cadres, entrepreneurs and managers with business brains. They are the "software" of the economic society and are very important. While doing business with foreign bosses, we often suffer some losses because we lack this kind of talent and thus give the foreigners a chance to make a lot of extra money from us.

In capitalist countries, children are taught to learn the knack of doing business. While studying in France, one day I went with some of my friends in the lab to suburban Paris. When we were resting in a coffee shop, we were attracted by a hub-bub from afar and went over to see what it was. We saw a large group of children bustling about each holding something in his hand. We found out that it was "Children's Free Market." Some 7 - 10-year olds were trying to sell the toys which they had got tired of and, with the money they made from selling their old toys, buy some other toys they liked. When these children grow up, they will naturally be very smart financially. This is how the knack of doing business permeates into each level of the society.

We should not look down upon commerce anymore. Instead, we should encourage scientists and technologists and cadres to learn a little about the knack of doing business. Besides, we should try to get some of these people to become entrepreneurs so as to adapt to the battle of the international economy.

Enjoyment in doing business has become a new concept in Shenzhen, our special economic zone. When people, be they writers or scientists or technologists, get together there, they often talk about business too besides talking about their own field. When getting a new cadre, a unit's main concern is whether this person knows about doing business. People no longer try to avoid "merchants' habits." On the contrary, people enjoy saying that they are "merchants" thinking that being able to make money within the limits of laws and normal morality is the sign of a capable economic worker.

The international technical revolution which has resulted in scientific and technological progress has not only unfurled a campaign for reform in many of our regions, departments and enterprises, but will also necessarily evoke a reform in people's concepts. Some of our traditional concepts will be replaced by new ones. These new concepts, in turn, will promote the development in reform. This is an irreversible trend and fashion. The Chinese people's economic development will be carried out through the reform. As long as we fight together and make concerted efforts in the reform, our economic "take-off" can be expected soon. A prosperous and powerful socialist China will then certainly stand lofty and firm in the eastern hemisphere.

12369

CSO: 4008/225

NATIONAL DEVELOPMENTS

WORKSHOP ON SCIENTIOLOGY, NEW TECHNICAL REVOLUTION HELD

Trianjin KEXUEXUE YU KEXUE JISHU GUANLI [SCIENTIOLOGY AND MANAGEMENT OF SCIENCE AND TECHNOLOGY] in Chinese No 12, 12 Dec 84 pp 13-15

[Article by Chen Tuguang [7115 0960 0342] of the China Association for Science and Technology Lecturing Group in Modern Management Information: "A Big Event in Science in China 1984"]

[Text] An information workshop on the new technological revolution for Central Party and political organizations was sponsored by six ministries and commissions including the Organization Department under the Central Committee, and the Chinese Association for Science and Technology from March through October, 1984. The participants were mostly leading cadres at the level of director and above from the Party Central Committee and State Council. The workshop, by its contents, its lectures, its organization of educational work and its repercussions on society, can be considered a big event in the 1984 Chinese scientific field.

(I) Major Contents of the Workshop

The content of this workshop roughly consisted of three parts: 1. Introducing, in an overall macroscopic way, the current situation, trends and future of the new international technical revolution and its influence on the modernization construction of socialist China; introducing our strategic guiding ideology in facing the challenge from new technical revolution and various kinds of ideas and suggestions for the studies in countermeasures. 2. Introducing the trends of techniques such as microelectronics, modern communication, biotechnology, new materials, new energy technology, marine technology, the integration of mechanics with electronics, etc. Stressing the conditions of development and function of new techniques in foreign countries, our own conditions, where we lag behind as well as our national conditions and countermeasures in the light of the needs of leading organizations and cadres. 3. Introducing methods of confronting challenges and searching for countermoves which leading organizations and cadres should know. How to make use of the principles, methods and techniques of modern management sciences such as systems engineering, etc. to promote fundamental change in leaders' ideology and continuous improvement in the level of management, thereby accelerating progress in our science and technology, economic and social development and the speed of our modernization construction.

These contents are all covered in the study of scientiology. Because a subject, whatever it is, generally has one certain thing in the objective world as its target. It is a kind of systemized knowledge or theoretical system gained once the subject's pattern of development and changes is mastered. Scientiology is exactly a study of overall science and technology. After studying the movement pattern of its subject's development and changes, it gradually becomes a theoretical system in relation to the development of science and technology, economy and society. Its scope is wide. Based on the appearance of the subject groups of the new technical revolution and the industry groups of the new industrial revolution, the workshop's focus was how our country should introduce new techniques to develop our scientific and technological affairs. Other focuses include major strategic problems in relation to the coordinated development of science and technology, economy and society such as how to set up new industries, reform our traditional industries, etc. Therefore, the content of the workshop completely tallies with that of scientiology. Last year, comrade Zhao Ziyang made a speech on welcoming the challenge of the international technical revolution and comrade Hu Yaobang issued a letter concerning the new technical revolution. Since then, quite a lot of cadres of various levels from local and central organizations have requested information on the new technical revolution and modern management. Their sense of crisis, pressure and responsibility is strengthened. In accordance with the instructions of the leading comrades from the Party Central Committee, this large-scale workshop was held with the sponsorship of six departments and organizations including the Organization Department under the Central Committee and the Ministry of Labor and Personnel, the State Scientific and Technological Commission, the China Association for Science and Technology and party committees of departments under the Party Central Committee, party committees of state organizations. Many famous scholars and experts in the field of scientiology were invited to report to leading cadres from the Central Party and political organizations and introduce to them the contents of new technical revolution and scientiological studies. Meanwhile, similar workshops were held throughout the whole country and more experts in scientiology were invited to report to party and political leading cadres on the new technical revolution. This is a big event worth recording in the history of scientiology.

(II) The Lecture Organization of the Workshop

The workshop's lecturing organizer was the China Science and Technology Association's modern management information lecturing group. For the teaching program of the workshop, responsible comrades of the lecturing group first worked out a tentative plan by soliciting the opinions of leaders and experts from the Chinese Academy of Sciences, State Scientific and Technological Commission and China Science and Technology Association. Later on, the plan was discussed by the sponsoring unit and submitted to the leading comrades of the Party Central Committee for approval. Aside from Fang Yi [2455 3015], member of the Central Committee of Politburo and State Council who did the mobilization and Wang Zhaohua [3769 3564 5478], deputy director of the Organization Department of the Party Central Committee who did the summarization, most of the lecturers of the workshop were consultants and part-time teachers of the lecturing group.

The reason for this is that information on the new technical revolution is a new subject group. Nowadays, the classification of science can no longer be covered by the 2 general categories, natural sciences and social sciences. Between natural and social sciences, many borderline subjects, overlapping subjects and comprehensive subjects have appeared as the theoretical basis for information in modern management. Scientiology is among these subjects. Of the experts and scholars joining scientiological field, many used to work on scientific research including natural sciences, technical sciences, education, systematic sciences, etc. However, as soon as they started the study of scientiology, they began new research by making sure of their previous subjects as the basis and absorbing the achievements of other subjects. There was not one exception among the experts and teachers who joined in the lecturing group.

In recent years, many comrades serve to improve our economy by studying, on an overall way, the law of development of foreign and domestic scientific and technological affairs, strategies for coordinated development of science and technology, economy and society, scientific and technological policies and management and ways to mobilize the enthusiasm of scientists and technologists. As their subjects are all very important ones, these comrades gradually attract the attention of various level of local governments and are invited to be brain trusters. Moreover, local party and government are paying more and more attention to them because they have played a significant consultative role. The fact that this workshop has received the attention of concerned leading cadres from the Party Central Committee is a natural trend of history and an inevitable result of the development of scientiological work.

In the new technical revolution information workshop held by the Party Central Committee, although there were only 20 specialists and scholars who got on the stage to give reports including Qian Xuesen [6929 1331 2773], Ma Hong [7456 3163], Huan Xiang [1360 6763], Wu Mingyu [0702 2494 3842], Li Baoheng [2621 1405 1854], Guo Pingxin [6753 1627 2946], Zhong Yixin [6988 5030 0207], Cao Tianqin [2580 1131 2953], Shi Changxu [1597 2490 4872], Feng Zhijun [7458 0037 3182], Song Jian [1345 0256], Yang Peiting [2799 3099 7200], Wang Zhuxiang [3769 4376 5046], Luo Zhengru [5012 6891 1172], Jiang Yaolin [5592 1031 7792], Lin Zixin [2651 5261 2450], Luo Wei [5012 0251], Liu Yuanzhang [0491 3293 1728], Liu Ji [0491 0679] and Tian Fu [3944 1133], almost each workshop lecture is the creation of collective effort and result of everybody's wisdom and strength. The situations include: 1. many lecturers of the China Science and Technology Association's Lecturing Group on modern management prepare lectures together; 2. Leading party groups of concerned ministries and commissions, Party Committees of colleges and universities, academic committees and specialists help in preparing lectures of going over manuscripts; 3. Specialists from state and local study groups which deal with challenges and make countermeasures help in preparing lectures; lecturers assimilate the study groups' achievements. The fact that so many specialists and scholars were mobilized for this workshop is unprecedented. This means that: not only existing scientiologists were invited, one after another, to make reports, but, through this workshop, the research team on scientiology was further enlarged, thereby greatly increasing the strength of the "lecturer group".

(III) The Workshop's Influence on the Development of Scientiology

During the 1950's, some people began studying scientiology in our country. Since then, the number of people studying scientiology has increased. By the late 1970's, scientiological researchers gradually became a group. A scientiological research association came to existence in our country in the early 80's. Last year, the national academic degrees committee of the State Council even approved that scientiology could recruit graduate students throughout the country. Many colleges and universities have courses in scientiology. Scientiology has entered a new stage in China.

The field of scientiology in China has been hoping that more leading cadres at various levels will receive information in this area so that they can contribute at every level of party and government organizations while working on strategies such as the coordinated development of science and technology, economy and society. Leading cadres from the Party Central Committee and the bureaus and offices of the State Council generally reflected that, through this workshop, their "vision has been broadened and knowledge increased; that they began to understand the current situation of the international technical revolution and its trends as well as our present condition and where we have lagged behind in the new revolution." Through this workshop, they gained a better understanding of the spirit of comrade Zhao Ziyang's speech on 9 October last year and comrade Hu Yaobang's letter in November. They felt that they could not stand still. Their sense of crisis, imminence and responsibility was increased.

More and more stress is being placed on developing intelligence and continuing education by many missions and committees. Plans for cadre training are, one after another, being revised and investment in intelligence is increased. Some ministries have even set up cadre training centers, thereby enabling organizations to adapt to the needs of modernization construction even better. This is a very strategic foresight.

After participation in the workshop, some units put things together and set out heartening steps to "meet the challenge." For example, comrades of industrial and commercial banks saw that a large amount of financial data including funds, currency, etc. could not be properly utilized because of the lack of advanced information processing measures, which affects the role of information. To improve the situation, those comrades are formulating a multi-leveled bank computer system plan appropriate for our practical conditions by first starting with the popularization of micro-computers and then gradually setting up a computer network. Meanwhile they help the information departments of some key cities to carry out automated office work and provide, in time, national financial departments with a lot of precise economic information. Comrades of the National Planning Committee who participated in preparing the "Seventh 5-Year Plan" worked out a plan in accordance with the trends of the new technical revolution; when dealing with problems concerning technical transformation, product development, etc. they took new measures to suit the development trend in the new international technical revolution. The Ministry of Chemical Engineering, as a special effort, imported 146 microcomputers and accelerated their speed of using new techniques

The progress which we have made in technology promotes the great realization of economic and social development which undoubtedly will give impetus to the

development of studies in scientiological theories. The second golden age of Chinese in scientiological theories. The second golden age of Chinese science today can also be applied to the field of scientiology.

(IV) The Social Significance of the Workshop

Most of the audience of the workshop were comrades who have been working many years as cadres in party and political work and as specialists in social science research. They deeply feel that the natural scientists who lectured in the workshop by using Marxism-Leninism and Mao Zedong thoughts as their guide in studying natural sciences have found many treasures lying in the Marxist-Leninist treasure-house. Especially worth mentioning is that some natural scientists who have switched to the study of scientiology, management science, leadership, etc. have gained a lot of knowledge in financial and social science and vividly reflect the coalition of natural and social sciences and promoted the comprehensive development of science. Social scientists such as Ma Hong, Huan Xiang, etc. are very much admired in our country for their studies of new international technical revolution from the point of economic and social sciences and our counter measures. It is believed that more social scientists should follow their examples by contributing to the coalition of natural and social sciences as well as to development of Chinese economy. The comrades of the Central Translation Bureau believe there are a lot of treasures of this sort in the works of Marxism-Leninism and they will do their best to gather together the treasures and make them available to everybody by translating the works. They will, with Marx and Lenin as their models, be concerned about, study, summarize and absorb the achievements of contemporary natural sciences and develop Marxism-Leninism. Through this workshop, some specialists of the Chinese Academy of Social Sciences, one after another, have asked to join the lecturing group. This will help the ranks of scientiology grow day by day. As can be predicted, the cooperation of two major forces will give great impetus to the coalition of natural and social sciences.

Although this workshop is just a prelude to the coming of our new technical revolution, it is a great event for Chinese scientiology in 1984.

12369

CSO: 4008/225

NATIONAL DEVELOPMENTS

PSYCHOLOGICAL FACTORS ON DEVELOPMENT OF S & T MANAGEMENT PERSONNEL

Trianjin KEXUEXUE YU KEXUE JISHU GUANLI [SCIENTIOLOGY AND MANAGEMENT OF SCIENCE AND TECHNOLOGY] in Chinese No 12, 12 Dec 84 pp 36-37

[Article by Wang Jisheng [3769 2817 4141], Psychological Research Institute of the Chinese Academy of Sciences]:

[Text]

I

Factors in academic psychology are important to both the development of scientific and technical work and the development of scientific and technological management personnel. Therefore, strengthening academic psychology can promote the development of scientific and technological management personnel.

In this article, I will try to explore the mutual relationship and function between certain academic psychological factors and bring forth some measures as to how to improve the academic atmosphere and promote the development of scientific and technological management personnel. (The academic psychological factors mentioned in this article include academic atmosphere, academic discussions, scientific research cooperation, scientific research competition and scientific friendship.)

Psychological scales and quantitative analysis were adopted in this work. Each academic psychological factor which has a role in the development of scientific and technological management personnel has 5 answers, i.e. very large, relatively large, same, relatively small and very small. A 5-point scoring system was used for the answers. Results of the research were processed by computers.

II

We analyzed the five academic psychological factors of the subjects on the development of scientific and technological management personnel to find out the correlation coefficient. For results see Chart 1.

Chart 1. The Correlation Coefficient of the Scores of Certain Academic Psychological Factors' Influence on the Development of Scientific and Technological Management Personnel

Correlated Items	No. of People	Degree of Freedom	Correlation Coefficient	Degree of Relation
Academic Atmosphere & Academic Discussion	48	46	0.6462	very significant
Academic Atmosphere & Scientific Research Cooperation	48	46	0.3811	very significant
Academic Atmosphere & Scientific Research Competition	48	46	0.4628	very significant
Academic Atmosphere & Scientific Friendship	48	46	0.4284	very significant
Academic Discussion & Scientific Research Cooperation	48	46	0.3487	significant
Academic Discussion & Scientific Research Competition	48	46	0.4705	very significant
Academic Discussion & Scientific Friendship	48	46	0.4599	very significant
Scientific Research Cooperation & Scientific Research Competition	48	46	0.6787	very significant
Scientific Research Cooperation & Scientific Friendship	48	46	0.5556	very significant
Scientific Research Competition & Scientific Friendship	48	46	0.7185	very significant
The degree of freedom is 46, $t_{0.05} = 0.288$			$t_{0.01} = 0.372$	

As can be seen in Chart 1, very remarkable significance in the correlation coefficient can be seen among the development of scientific and technological management personnel and academic atmosphere and academic discussion, academic atmosphere and scientific research cooperation, academic atmosphere and scientific research competition, academic atmosphere and scientific friendship, academic discussion and scientific research cooperation, academic discussion and scientific friendship, research competition, scientific research cooperation and scientific friendship, scientific research competition and scientific friendship. This shows that these factors are closely related to the development of scientific and technological management personnel and are internally connected to it. The fact that there is remarkable significance in the correlation coefficient between academic discussion and scientific research cooperation and the development of scientific and technological management personnel shows that they are closely related and are internally connected. As the result shows, the more important role academic atmosphere plays in the development of scientific and technological management personnel, the more important academic discussion, scientific research cooperation, scientific research competition, scientific friendship are to the development of scientific and technological management personnel. Similarly, the more important role academic discussion plays in the development of scientific and technological management personnel the more important co-operation and competition in scientific research and scientific friendship are to the development of scientific and technological management personnel. The more important the role co-operation in scientific research plays in the development of scientific and technological management personnel, the more important competition in scientific research and scientific friendship are to the development of scientific and technological management personnel. The more important the role competition in scientific research plays in the development of scientific and technological management personnel, the more important scientific friendship is to the development of scientific and technological management personnel.

Some people make the mistake of considering co-operation and competition in scientific research to be opposites. In fact, in scientific research work, there are unhealthy cases where scientific research co-operation and scientific research competition, scientific research competition and scientific friendship are set against one another. As this research shows, in their relation with the development of scientific and technological management personnel they are connected to and conditioned by each other. Of the 48 research subjects, those who score one, two and three in each academic psychological factor among several academic psychological factors are put in group one and those who score four and five are put in group two. Chart two displays the means, standard deviations and t-test result of groups one and two for four academic psychological factors.

As Chart two shows, the group scoring four or five has a higher mean score in its appreciation of the relationship of academic atmosphere with the development of scientific and technological management personnel than has the group scoring one, two or three in the relationship among academic discussion, co-operation in scientific research, competition in scientific research,

scientific friendship and the development of scientific and technological management personnel. The t-test difference of the mean scores for academic discussion and competition in scientific research reaches a significant level. This shows that the function which academic atmosphere has on the development of scientific and technological management personnel, be it large or small plays a certain role in academic discussion, co-operation in scientific research, competition in scientific research and scientific friendship.

Chart 2. Test on the Correlation Between Academic Psychological Factors and the Development of Scientific and Technological Management Personnel

	Items	The Mean and Standard Deviation of 1-, 2- and 3-score Group	Mean and Standard Deviation of 4- and 5-score Group	Significance of t-test
Academic Atmosphere	on Academic Discussion	2.964 ⁺ 0.5874	3.857 ⁺ 0.655	very significant
	on Scientific Research Cooperation	2.667 ⁺ 0.7842	3.143 ⁺ 0.7931	significant
	on Scientific Research Competition	2.333 ⁺ 0.9607	3.048 ⁺ 0.805	very significant
	on Scientific Friendship	2.63 ⁺ 0.8883	3.143 ⁺ 0.9638	insignificant
Academic Discussion	on Academic Atmosphere	2.963 ⁺ 0.6496	3.81 ⁺ 0.6017	very significant
	on Scientific Research Cooperation	2.704 ⁺ 0.7239	3.095 ⁺ 0.889	insignificant
	on Scientific Research Competition	2.444 ⁺ 0.9338	2.905 ⁺ 0.9434	insignificant
	on Scientific Friendship	2.593 ⁺ 0.7969	3.19 ⁺ 1.0305	very significant
Scientific Research Coop.	on Academic Atmosphere	3.205 ⁺ 0.7321	3.889 ⁺ 0.6008	very significant
	on Academic Discussion	3.271 ⁺ 0.7423	3.889 ⁺ 0.6008	very significant
	on Scientific Research Competition	2.436 ⁺ 0.8826	3.556 ⁺ 0.7266	very significant
	on Scientific Friendship	2.641 ⁺ 0.8729	3.778 ⁺ 0.6663	very significant
Scientific Research Comp.	on Academic Atmosphere	3.244 ⁺ 0.7342	3.851 ⁺ 0.6899	significant
	on Academic Discussion	3.268 ⁺ 0.7078	3.857 ⁺ 0.9	insignificant
	on Scientific Research Cooperation	2.756 ⁺ 0.7994	3.571 ⁺ 0.5348	very significant
	on Scientific Friendship	2.863 ⁺ 0.8497	3.857 ⁺ 0.9	very significant

Scientific Friendship	on Academic Atmosphere	3.194 ⁺ 0.749	3.75 ⁺ 0.6213	very significant
	on Academic Discussion	3.167 ⁺ 0.6971	3.917 ⁺ 0.6686	very significant
	on Scientific Research Cooperation	2.667 ⁺ 0.9437	3.5 ⁺ 0.5225	very significant
	on Scientific Research Competition	2.333 ⁺ 0.8283	3.583 ⁺ 0.6686	very significant

The effect of academic discussion on the development of scientific and technological management personnel is higher in the 4- and 5- score group than the effect of academic atmosphere, scientific research cooperation, scientific research competition and scientific friendship has on the development of scientific and technological management personnel in the 1-, 2- and 3- score group. Of this, the difference in the t-test of mean of both groups' academic atmosphere and scientific friendship on the development of scientific and technological management personnel is very significant. This shows that the effect, whatever the scale is, of academic discussion on the development of scientific and technological management personnel has certain influence in academic atmosphere, scientific research cooperation, scientific research competition and scientific friendship.

The mean of the effect of scientific research cooperation on the development of scientific and technological management personnel is higher in the 4- and 5- score group than that of the effect of academic atmosphere, academic discussion, scientific research competition and scientific friendship on the development of scientific and technological management personnel in the 1-, 2- and 3- score group. Of this, the difference in the t-test of the mean of both group's effect of academic atmosphere, academic discussion, scientific research competition and scientific friendship on the development of scientific and technological management personnel is very significant. This shows that whatever effect scientific research cooperation has on the development of scientific and technological management personnel has a significant influence on the role of academic atmosphere, academic discussion, scientific research competition, scientific friendship in the development of scientific and technological management personnel.

The mean of the effect of scientific research competition on the development of scientific and technological management personnel is higher in the 4- and 5- score group than that of the effect of academic atmosphere, academic discussion, scientific research cooperation and scientific friendship on the development of scientific and technological management personnel in the 1-, 2- and 3- score group. The difference in the t-test of the mean is very significant in both groups' effect of scientific research cooperation and scientific friendship as well as their effect on academic atmosphere. This shows that the role of scientific research competition on the development of scientific and technological management personnel has a certain significance on academic atmosphere,

academic discussion, scientific research cooperation and scientific friendship' effect on the development of scientific and technological management personnel.

The mean of the effect of scientific friendship on the development of scientific and technological management personnel is higher in the 4- and 5-score group than that of the effect of academic atmosphere, academic discussion, scientific research cooperation and scientific research competition on the development of scientific and technological management personnel. Of this, the difference in the t-test of the mean is very significant in both groups' academic atmosphere, academic discussion, scientific research cooperation and scientific friendship. This indicates that the effect of scientific friendship on the development of scientific and technological management personnel has a certain significant influence on academic atmosphere, academic discussion, scientific research cooperation and scientific research competition.

The result of the above research shows that in their effects on the development of scientific and technological management personnel, academic psychological factors, i.e. academic atmosphere, academic discussion, scientific research cooperation, scientific research competition and scientific friendship influence and promote each other. To improve any of the academic psychological factors' role on the development of scientific and technological management personnel will help to improve other factors' role as well. To improve the role of scientific research cooperation and scientific friendship on the development of scientific and technological management personnel will particularly improve the significance of academic atmosphere, academic discussion and scientific research competition on the development of scientific and technological management personnel. The improvement of academic psychological factors is important not only to the promotion of scientific research but also to the development of the scientific and technological management personnel.

III

The following is a conclusion drawn from the result of the quantitative study of the research:

1. In their relation with the development of scientific and technological management personnel, the correlation coefficient of any two of the five academic psychological factors, academic atmosphere, academic discussion, scientific research cooperation, scientific research competition and scientific friendship, all reach a very significant level. These factors are very closely related to the development of scientific and technological management personnel, except academic discussion and scientific research cooperation whose correlation coefficient reaches a significant level and are closely related.
2. The role of academic atmosphere, academic discussion, scientific research cooperation, scientific research competition and scientific friendship in the development of scientific and technological management personnel respectively affects, in one way or another, the other four academic psychological factors' role.

3. To improve academic psychological factors in particular, scientific research cooperation and scientific friendship and their role in the development of scientific and technological management personnel also helps the development of scientific and technological managers.

12369

CSO: 4008/225

NATIONAL DEVELOPMENTS

LUO WEI ON RELATION BETWEEN ECONOMY, S & T

Tianjin KEXUEXUE YU KEXUE JISHU GUANLI [SCIENTIOLOGY AND MANAGEMENT OF SCIENCE AND TECHNOLOGY] in Chinese No 12, 12 Dec 84 pp 2-5

[Article by Luo Wei [5012 0251], Chinese Academy of Sciences.]

[Text] Comrade Zhao Ziyang has pointed out that one of the major problems to be worked out in the reform of the scientific research system is the separation of scientific research from production. This is indeed an important problem today. On analyzing the relation between economic development and technical progress, we find that there is no obvious macroscopic correlation between them. In other words, policies to strengthen research and development do not necessarily bring about corresponding economic development. There is a big gap existing between science and technology, and economics. With the problem left unresolved, there is no way for scientific and technological achievements to become an economic factor, enter the economic process and realize anticipated economic goals. We must see that the understanding and resolution of this problem confronting us is a special question different from that faced by the advanced countries. How the problem is solved will have a basic and long-term influence on the quality and level of our economic development as well as the impetus and stability of our scientific and technological development.

On commenting upon measures to solve this problem, many comrades emphasize the improvement of our ability to forecast trends in our scientific, technical and economic development. Today when the period for technological innovation is continuously decreasing and its frequency continuously accelerating, our forecasting ability is obviously unsatisfactory. It is very important for us to understand the practical necessity of increasing such ability. However, on reviewing our history after the founding of the PRC, we quickly understand that this is not the key that is restricting our economic and scientific and technological development. We should say that the technological field in which the modern technological revolution involves is not new to us. People should remember that in 1956 when we were working on a 12-year plan for scientific and technological development, we had, as emergency measures, not only anticipated development in electronics, semiconductors, computer technology, automation, atomic energy and jet technology but also adopted decisive policies. Even for laser technology, new materials, aviation technology and biotechnology, etc. which were developed later, our knowledge and arrangements, we should say, have been timely. From historical data,

there were very few cases in which we were left completely unprepared for important trends in research and development because of mistaken predictions.

Similarly, we should say that as for technological breakthrough and tackling problems, our ability in the technological fields involved in the new technological revolution needs to be improved. To adopt practical and effective measures so that we can continuously improve our ability in tackling problems should be made an established policy to be carried on persistently over a long period of time. However, as history has proven, as long as our policy and organization are appropriate, we will not only be able to achieve breakthroughs but the speed and quality of our work will not be considered poor. The problem with this ability is that it can only be used to show our scientific and technological power and can only be used once for a specific goal. This ability cannot be transformed into economic procedures nor become an economic capability, nor a mature industrial technology or a new industry.

The basic factor holding back our adjustment to the present economic situation of incessant renewal of industrial technology is the lack of a driving force towards transformation and the absence of any channels to guarantee the practice of transformation. If we do not pay attention to the study of transformation and coordination mechanisms and the construction and perfection of their structure, so as to raise them to the level of strategic policy, it will be very difficult for the functions of various elements to be combined into final economic benefits. Also it will be very hard to change fundamentally the lag in industrial and technological structure.

To begin with, let us review the formation of this kind of transformation procedures in a capitalist society.

During the early stage of a technological revolution, quite a few of the impacts on industry were realized by inventors with their own technological inventions. Later on, regular industrial labs which were solely intended for technological invention appeared in enterprises. With the basis of technological inventions becoming more and more scientific, traditional industrial labs become the research and development departments of enterprises which directly link up science, technology and production within enterprises. After World War II, as the result of the increase in the influence of science and technology on the economy and its ever-increasing investment scale in order to meet the demands of its ever-growing social functions, the state to a large extent has been involved in the development of science and technology and has become an important factor in the communication among science - economy - society in the social sphere. Thus, scientific and technological development becomes more deeply and broadly socialized. The exploration and utilization of scientific and technological achievements and the procedures in which they are transformed into practical economic ability becomes, from a once random and loose structure, one which is highly organized and relatively stable. A complete transformation chain which links up scientific theories and production techniques has come to exist in the research and development sections of enterprises, state labs and government research organizations and universities. Some people have said that the integration of science and technology with industry in the advanced western countries results from their long-term experiences in development. On the

other hand, this sort of integration is an anticipated positive premise in the developing countries. There is one truth in this statement.

In the advanced capitalist countries, the transformation structure of science and technology and economy is made possible, first of all, by the fact that capitalism makes technological revolution indispensable in the realization of its own economic mechanism. As a result, the economic utilization of a scientific and technological achievements is not, to begin with, that they are themselves needed but that they are essential for economic development. Thus, not only the exploration and utilization of scientific and technological achievements receive incentives and support from the economy, but the organization and structure of scientific and technological affairs are, under such incentives, carried along and organized in favor of the realization of economic goals to the greatest extent possible, and become the inner and organic component in the capitalist economic activities. The formation of the science and technology -- economy transformation structure is not something added to economic activities, but a spontaneous and natural product of the procedure in which the economy carries out its own goals. If a technological revolution is not based on the demands of the economy itself and the construction of an effective transformation, even though in form it is perfect in each link, will have difficulties having any internal and constant relationship with economic procedure. Scientific and technological achievements will not be able to become an economic capability either by entering economic procedures and realizing the economic benefits they should have with them.

There are many links existing between research and development - production - market. Research is generally divided into basic and applied research; development and from development to production can be divided, in more details, into prototyping - evaluation - engineering design - immediate testing - technological design - equipment, etc.

Research and development must push production forward while production and the market must pull along research and development. This is the "economic construction must rely on science and technology and science and technology must be geared to economic construction" policy laid down by the Party Central Committee.

Pushing and pulling are not simple at all. The problem is that basic research obtains knowledge by exploring the objective laws of things. It does not have a definite application goal. Although applied research has a definite application goal, its achievements are still informational and cannot be directly used in production. On the other hand, the needs of the society and of production are generally brought out in the form of aspiration, intention, tasks and products. It is hardly possible for them to bring out scientific problems or research topics directly. For example, as consumers, we hope that fruit and vegetables can be kept longer. However, it is generally beyond us to decide which method: refrigeration, irradiation, nitrogenization or other procedure is the most economic, effective and safe.

Another problem is that research organization are generally set up in accordance with a subject or a profession. There is no doubt that in so doing,

it makes the study of problems more thoroughgoing. Yet, since products are generally comprehensive in nature, it is almost out of the question for one research institute to produce a complete modern watch, as an example, as far as the material, machinery, circuits, liquid crystal, etc., involved are concerned. Therefore, it is necessary for enterprises to decompose the problems of production into those which they can bring to appropriate research institutes. Researchers can also suggest where their knowledge and achievements can be used.

Still another problem is that generally laboratory work only decides technical possibilities. However, technical possibilities are not equal to production and marketing possibilities. Because the use and production of one achievement requires investment, place for production, equipment and the supply of crude materials, components, etc., after these problems are solved and products are produced, there are still a series of problems, such as whether the products suit market demand, and whether they can make a profit. All these require technical and market evaluations which remain very weak up to now. Besides, many of the achievements of laboratories, before they are put into production, must go through immediate and production experiments. Up to now, immediate experiments are often not arranged properly.

The situation today is that high-technology products are developing very fast, changing almost with each passing day. To adjust to this situation, it is doubtless that our capability in research and development must be strengthened. However, one thing of equal importance is that we should accelerate the movement in the immediate links.

We must first strengthen the research and development capability of enterprises. Speaking from the comprehensive definition of an independent enterprises, it is not only a production unit, but also a management unit which must confront directly the competition in the market and strive for existence and development. Thus it is determined that: (1) it must have a good command of a large quantity of practical information about its interior economic strength and the tendency of exterior markets. These are necessary for making technical policies and guiding and regulating research and development activities; (2) It must have independent financial ability to be used in research and development activities and new technologies; (3) It must have, in the day-to-day market competition, a self-consciousness in using new technologies as well as initiative in carrying out research and development activities. Thus, since the enterprise has its own research and development section, its scientific research and production activities can be managed comprehensively. On the one hand, the managers of enterprises can, on the basis of market investigation and forecasting and the adaptability analysis of interior strength, provide their research and development sectors with effective information on market demand for technological development and resources for research and development. The synchronous input of such demand information and development conditions will not only increase the transformation ratio of the achievements in technological development, but will also improve efficiency. On the other hand, once technological achievements have developed, the enterprises will, under comprehensive, planned arrangements, create favorable conditions for the production, marketing and service necessary for the achievements' popularization and utilization, thereby transforming them into

competitive practical economic ability. Moreover, the research and development sectors of enterprises are also responsible for absorbing knowledge and achievements from the outside world and transforming them into technologies useful for the enterprises themselves. This kind of comprehensive management of technological development, production, organization and marketing results in high coordination between different activities, and the shortest information and material communications route on a reasonable basis, thereby guaranteeing effective progress of transformation.

From gaining scientific and technological achievements to the formation of economic capabilities, it is without doubt that the first enterprise level is not the only section which realizes them. State and society also play an important part in it. Generally speaking, the government has two functions: one is to directly support research and development activities by allocating funds, the other is to bring about and influence the investment conditions of research and development, and the utilization of new technologies through administrative legislations such as policies, codes, revenues, etc. Different social organizations, universities above all, play the role as supplier of knowledge and talents.

Of the general structure of research and development in capitalist countries, government investment makes up about one half in western Europe and the United States while in Japan the proportion is one third. Traditionally, the budget for research and development spheres such as basic research, sophisticated technology and national security which are aimed at the society is taken care of by the government. The reason for this, besides the fact that they are the higher level needs of the society, that they need a lot of investment, that enterprises cannot benefit from them directly, is that the scientific and technological achievements gained in these spheres always promote the technology of the society. As we know, technological progress is generally carried out in two patterns. One pattern is gradual. It is the consumption, improvement and popularization of the practical utilization pattern of a technology, after a technical revolution has happened, during the process of actually adopting it and expanding its utilization depth and width in order to increase its economic benefit. Here, the actual production experiences as well as the specific problems which appear during the production and consumption process all have a significant bearing to the further improvement of the technology. This kind of technical development and transformation is realized through the typical pulling force which engenders effective demands. However, not all achievements are accepted by enterprises. If there is only one channel, it is quite possible that a lot of technologies with great vitality, even with great prospects will be overlooked. Particularly under the condition of the new technical revolution, economic benefits increase the dependence on scientific research. The fact that scientific research has obviously gone ahead of production brings about the so-called activities that create demand. This means that some demand, instead of arising from consumers' consciousness, is created by new scientific achievements. This is a mutant type of technology, another condition of technological progress. It can result in the existence of a new industry and the basic reconstruction of old industrial technologies. When people are still unfamiliar with what possible influences this kind of new technology will bring to the economy, it is very difficult for it to be included in the transformation procedure. This will require the state's help.

It is necessary for research organizations to have a group of managing talents who understand the needs of enterprises and are able to find appropriate consumers for the achievements and knowledge of their own units. If besides the transfer of achievements, attention can be paid to the transfer of talents and knowledge, the result will be even better. This is because the development of science and technology itself can "create" new demands which cannot be brought up directly by producers and consumers. For example, some new materials and new technologies produced and adopted for national defense can be used in civilian products; some scientific instruments produced for scientific research gradually become the means of production in production departments. With the development of high technology, there will be more and more technologies and achievements which are pushed from research development to production departments.

Let us try to explain this situation by taking a look at the advanced capitalist countries where some university researchers, by making use of their knowledge in new technologies, open up their own enterprises or work part-time in enterprises. This is quite common in such spheres as microcomputers, biotechnology, micro-electronic components, etc. In many capitalist countries, there are laws protecting medium- and small-scale enterprises, preferential policies for investment, fundraising, credit, tax revenues, risks in high technology industries and specialized organizations for risk investment and credit guarantee. As a result, many researchers who, once they achieve some significant technical breakthrough, would, for the sake of their own economic benefit, raise capital in order to have their own enterprises if it is possible. They would use their new technology which is still unknown to others as their capital and join in the opening up of and competition in the market. When their enterprises show technical superiority and marketing prospect, they would, besides expanding the scale of business themselves, attract more investment. Thus, through the rapid expansion of the scope of utilization of new technology and its scale of production and sales, a social technical revolution is formed. In a sense, this kind of enterprise serves as an ongoing experiment for large-scale enterprises. The role of transformation is to transform technologies from pushing into pulling forces. Without this mechanism, a developed market does not mean new technologies and to wait for existing demands or look for them blindly will possibly delay or cause difficulties in completing the transformation procedure.

Flexible organizations can adapt easily. Aside from some dedicated to tackling certain problems, some research organizations and enterprises which have a fixed research direction or products should be made adaptable. For example, temporary organizations established for a certain research goal including various professions, various technologies and including research, development, production and sales departments. Another example, specialized professions -- consultant companies, risk investment companies which already exist. Although it is very difficult for such flexible organizations to exist in our current system, we must explore and find out a way which suits our national conditions. No doubt the scientific research and production integrated bodies which already exist and the proposals which are just now being proposed concerning the establishment of scientific and industrial parks are all very good. However, scientific research and production integrated bodies will be

short-lived if they just take over the production of some achievements from scientific research departments and turn them into final products, but do not transform new technologies and new products accordingly along with scientific research development into the direct mechanism of productive forces. Similarly, scientific parks will not be vital if they just have some factories producing high technology products by using the technological force of some nearby scientific research and educational institutes, but do not flexibly and continuously develop conditions including real estate, capital, transportation, communication, water and electricity, etc for medium- and small-scale enterprises which produce new high-technology products.

12369

CSO: 4008/225

NATIONAL DEVELOPMENTS

RE-EDUCATION AIMED AT CHALLENGE OF NEW TECHNICAL REVOLUTION

Beijing KEYAN GUANLI [SCIENCE RESEARCH MANAGEMENT] in Chinese No 1,
Jan 85 pp 1-4

[Article by Xia Guofan [1115 0948 5672] of the 608 Research Institute of the Ministry of Aeronautics: "Accelerate the Renewal of Knowledge of Technical Personnel To Meet the Challenge of the New Technical Revolution."]

[Text] The new technical revolution has begun in the world. The new trend in the area of technology is that new technologies and knowledge are emerging while technologies and knowledge are growing old at a faster rate. Faced with this cold reality, we must organize our technical personnel to learn advanced technology and current theories in time so that we can renew knowledge and meet the challenge of the new technical revolution.

I. A research unit is a place where technical talents are gathered. It is extremely urgent to renew their knowledge and to maintain continuing education. Our institute changed the concept of a "single education cycle" that technical personnel are only utilized, but never re-trained. We established the idea of "continuing education" which is a step closer toward systematically educating the staff members. Various types of formats including studying on one's spare time, technical investigation, technical research, international exchange, technical lecture, attending school on the job and short-term training courses, were used to create favorable conditions for the technical staff. In the past 4 years, there were 33 courses in special field, technology, fundamental theory and foreign language. More than 1,500 students attended. On the average, each technical person attended 2.5 courses. Each course involved 1,000 hours of teaching, equivalent to studying about 3.5 months without contributing to production. It was as an advanced unit in employee education in 1983. In April 1984, a speech on "Initiating Continuing Engineering Education To Accelerate Renewal Of Technical Knowledge" was given in the provincial cadre training workshop sponsored by the provincial committee. Through continuing education, 80 percent of the middle level technical members are basically aware of the modern theory and technology in their own field. A new atmosphere of abundance of talents and accomplishments begins to emerge. In the past 4 years, there were 29 scientific research accomplishments receiving major awards from the National Technical Conference, the Ministry of Aeronautics and the province of Hunan. In applying the finite element method and three-dimensional flow calculation to product design and strength

computation, our institute is the leader in the field. In fact, it has been proven that knowledge is not only a "lubricant" against aging but also a "catalyst" for technical advancement. It is important and urgent primarily because:

1. Knowledge renewal is needed to meet the new technical revolution. The challenge of the new technical revolution is essentially a struggle of talent and intelligence. When science and technology move forward in such a fast pace, the original knowledge of the technical personnel cannot meet the actual needs. For instance, most of the products were designed by the one-dimensional axial flow method. Now, the three-dimensional flow theory is required. In the past, classical mechanics was used to calculate strength. However, fracture mechanics, elasticity and plasticity are required. In these areas, numerical methods which were seldom taught in schools are used. Therefore, the technical people must constantly learn new knowledge, track new technology, explore new theory and exploit new areas in order to rapidly reduce the technical gap and control the "key spots" in modern technology.

2. Knowledge renewal is required to prevent aging of technology. Premier Zhao stressed that "the aging cycle of modern technology is becoming shorter and an advanced technology becomes obsolete in a few years." If we do not move the technology forward, it is bound to be eliminated. Especially after the 10 years of chaos, technical people were isolated from the new technology for over a decade. The aging of their knowledge is in sharp contrast to their responsibility. Only by accelerating knowledge renewal and improving technical quality can we catch up with the rapid progress in modern science and technology.

3. Knowledge renewal is required to ensure the implementation of the policy in science and technology. Technical work must be focused on economic development. Technical people are required to "process" their knowledge acquired in school and convert it into creative ability in terms of new technology and technique. Therefore, technical people must continuously study new technical knowledge in order to enhance this capability. The automatic rail machine successfully developed for the Ministry of Railways, three models of automatic mat weaving machines developed for the Ministry of Light Industry, automatic cotton swab machine developed for the medical equipment industry, and the first automatic bread baking line in China developed for the food industry are results of learning new knowledge to strengthen technical capability. It has been proven in practice that the policy of gearing technical work toward economic growth can best be implemented by accelerating the renewal of knowledge and transplanting most advanced technology to creative product development.

II. Renewal of technical knowledge must be directed toward the future with the objective of producing accomplishments, talents and benefits. Under the premise of political awareness as a communist and an expert, we must make an overall arrangement to effectively and flexibly achieve the following "six combinations:"

1. Combining knowledge in books with technical production. The source of intelligence is in books. The time spent on looking up information in books

occupies approximately 30-50 percent of the total research time for an expert in his career. Therefore, technical people must pay attention to books in order to absorb relevant information from periodicals and articles to minimize repetition and to reduce the research period. However, one should not remain buried in books. It is necessary to be able to analyze, summarize, judge and solve real problems by using theoretical knowledge. New knowledge should be applied in research and product development. For instance, the affiliated laboratory in our institute learned a fuel flow control and recirculation method which was used in the automatic control of the Model KT100 free turbine. It serves as an avenue to further study its regulating pattern. The testing laboratory studied satellite energy feeding and optical communications, and used them in the measurement of parameters of an extended rotating part. Subsequently, a new research topic on light induced electricity was introduced. When studying foreign nuclear physics detection and modified pump integration techniques, they successfully applied the F/V transformation technique in pump integration to develop a multi-purpose tachometer which received a major technical accomplishment award from the Ministry of Aeronautics. In practice, applying theoretical knowledge to technical production would promote the development of the technology. Further development in technology, however, will introduce new problems which require new theoretical knowledge. It works as a cycle that the technology is advanced, production is increased and knowledge renewal is accelerated.

2. Combining breadth with depth. Based on the special characteristics of knowledge explosion, information expansion and science penetration, the renewal of technical knowledge must focus on depth as well as breadth. One must not only become a "knowledgeable" person in relevant disciplines with a wide range of exposure but also be an expert in a special field. From the point of the power mechanics institute, people studying performance characteristics not only must be widely involved in microelectronics and calculation of structure and strength but also should thoroughly understand gas thermodynamics. People studying the structure not only should learn the characteristics of the entire unit and each component but also must know about the principles and structures of engines. People working on the strength problems not only must know testing methods and electronics but also have to have knowledge in mechanics and ability in testing and calculation. People in testing not only must study optics, high temperature science, reliability analysis and statistics but also should be familiar with testing methods, calculation principles and micro-electronic techniques. Thus, we can adapt to the trend of overlapping technology to simultaneously be broad and specialized.

3. Combining overall improvement with key personnel training. Everyone should study general knowledge and common technology. In general, new fundamental theories not taught in school in the past (such as linear algebra, differential geometry and fast transformation) and needed capabilities such as computer programming and foreign language translation should be widely promoted. Because our institute handled the renewal of knowledge well, especially in computer training, the majority of the technical staff can use a computer to solve their problems. Fifty percent can compile complicated programs. In the meantime, laboratory directors, principal engineers, group leaders and key staff members are also specially trained. Over the past 4 years, the institute sent technical people to attend international academic exchanges for more than 20 times. They serve as "seeds" to spread advanced technical knowledge to the technical staff.

4. Combining studying scientific knowledge with technical management. Science and technology is productivity. However, we must incorporate management skills to convert it to real productivity. According to statistics, the completion of a research project in a developed country relies 20 percent on capital and equipment and 80 percent on scientific organization and management. Therefore, modernization of technology should be placed on the same priority as modernization of management. When we organize the technical staff to study the "hard science," we should also guide them to study "soft science" - management. In 4 years, over 100 key technical and management personnel participated in three technical business classes primarily to learn "modern management," "decision making," "counter-measures," "reliability theory," and "principle and applications of value engineering" in order to change the current situation that technology and management are separated. This allows many technical and management personnel to be familiar with the technology as well as the business so that technical hurdles can be overcome with optimal economic benefit.

5. Combining filling voids in fundamental theory with renewal of knowledge. For completeness, fundamental theories in advanced mathematics, electrical engineering, materials science, mechanics and drafting should be supplied to high school graduates prior to the cultural revolution era and college graduates in that era to remedy their deficiency in basic theory. This will broaden their view and increase their potential. Our institute trained them in three batches and the majority of them attained the college level. They obtained engineer or assistant engineer titles and some has already become key technical personnel.

6. Combining learning foreign technology with creating Chinese technology. We must obtain worldwide information, track advanced technology and transplant it in China as our technical people renew their knowledge. In addition, we have to take shortcuts to digest, absorb, improve and create advanced technology starting with the state-of-the-art. In the development of Model JK8213 zero revolution monitor, the monitor development people designed an advanced detection circuit by referring to the information on the Model JT30 abroad. It lowered the speed from 70 RPM to 7 RPM and received a major technical accomplishment award from the Ministry of Aeronautics. An engineer applied the "iso-parametric finite element method" to analysis of product structures and achieved a new breakthrough. He established a "density transition element" which is capable of saving computer time. His paper was chosen by the International Society of Finite Element Method and was included in the symposium. It was also published in the "Journal of Mechanics" in China. Even foreign organizations such as London University in England had requested a reprint. We deeply felt that we should neither be too arrogant nor too humble. We should learn but should not copy. We must combine learning with creation to develop advanced technology suited for China so that we will always stand in the leading edge of modern technology.

III. The key to the renewal of technical knowledge rests on whether the leadership considers it as a major policy to meet new technical challenges to promote technical advancement and economic growth. We must be willing to do the following things:

1. The willingness to devote the efforts. The leadership is asked to overcome the thinking that "we cannot do it because the burden is too heavy and there, is not enough time." We must be willing to devote the effort. Institute directors and the secretary of the Communist Party should personally handle this matter. Deputy directors should pay attention to the specifics. The party committee should meet several times a year to make certain that renewal of technical knowledge is on the top of the agenda.

2. The willingness to assign key personnel. Effective renewal of technical knowledge, to a large extent, is determined by whether we are truly willing to spare key personnel's time to implement it throughly. We should make sure that we have a dedicated organization, skillful staff, adequate faculty and a team of key personnel to be trained. Thus, an employees education network is formed to ensure the implementation of ideology, planning, policy and organization.

3. The willingness to invest. The expense incurred in knowledge renewal is considered as an investment on intelligence which is an important part of technical investment. A technical research unit should set aside 1.5 percent of its regular salaries and 25 percent of union dues for employees training. The difference should come from profits. The required facility, instruments, equipment and teaching tools should be considered as a basic investment and be given priority. The required books and materials should be supplied in time. We must meet the minimum requirements in teacher's salary, cost for preparation of teaching materials and scholarship.

4. The willingness to provide the time. We must relieve the technical staff from the burden of meetings and odd duties to ensure that they have enough energy to combine technical work with "reeducation." We must insist on spending half a day per week to study the technical skill and on leaving the post a half to a month per year for school. Furthermore, the study records are kept in files as basis for promotion and review.

We are convinced that, as long as the relevant departments are handling the renewal of technical knowledge as an important strategy, then the prediction of Comrade Deng Xiaoping that "An era of many talents will come soon" will materialize in the near future (see "Deng Xiaoping's Selected Works").

12553

CSO: 4008/221

NATIONAL DEVELOPMENTS

PLANS TO READJUST ACADEMIC SOCIETIES PROPOSED

Beijing KEYAN GUANLI [SCIENCE RESEARCH MANAGEMENT] in Chinese No 1,
Jan 85 pp 10-14

[Article by Zhao Yingchun [6392 5391 4783] of Heilongjiang Society of Science and Technology: "Some Ideas on Academic Society Readjustment"]

[Text] Since the Third Plenum of the CPC Central Committee and the second general meeting of the Science and Technology Commission, academic societies have been on the road to rapid recovery. Societies and research groups are being formed. Currently, there are 94 provincial level societies (and a large regional level society) which is three times the number before the Cultural Revolution. Under these societies, there are 452 professional committees and sections with 39,000 members. There are over 1,000 local, city and county level societies with 85,000 members.

The societies have been very active. In recent years, the provincial societies alone held over 1,000 academic activities and 200 international academic exchanges. These activities played a consulting role to the leadership in managing production, directing science and technology, and making decisions in economic construction. In these activities, we acquired the latest information in the world which contributed to the renewal of technical knowledge and improvement of technical standards. Through inquiry, suggestion, investigation and verification, the conversion of science and technology to productivity has been accelerated. Because societies are the biggest supporter of new inventions and discoveries, many accomplishments were evaluated in these activities and many talented people were also recommended. Societies also actively reflect the opinions and request of scientists and technical people to protect their rights. They serve as the "bridge" between the Communist Party and technical workers.

However, because the organization is expanding so rapidly that newly emerged problems are not solved in time. To some extent, the level of society members is not comparable, which affects the improvement of the quality of activity. There are many overlaps among the secondary organizations which dilutes our strength. The board of directors is too old to be effective. Primary societies are expanding so fast that they are unbalanced. Secondary societies and organizations are treated as primary ones which causes confusion. Therefore, we must readjust and reorganize these societies.

The readjustment will be driven by a reorganization of the party, aiming at reform and creating a new prospect. Based on the request of the national society organization workshop, we adopted the policy of "leaving the majority unchanged and making minor adjustment." The fundamental principles of readjustments are:

1. Readjustment must agree with the policy of technical development. It must face the economy, strengthen applications, focus on fundamentals, combine natural and social sciences, and support the development of new and leading edge technology.
2. Readjustment must favor the development of technology to allow societies to be fully utilized as a lateral contact in order to mobilize the enthusiasm of the members and the technical staff.
3. Readjustment must facilitate scientific management of the societies. Through readjustment, the scope of each society and cooperation between societies are clearly defined to avoid unnecessary redundancy.
4. Readjustment of societies must take the quality of the team into consideration. We must have reputable leaders, enthusiastic workers and qualified members. We must have the capability to independently conduct academic exchanges and hold various activities.

I. Readjustment of Members

When societies were reinstated, because of differences in standards, the quality of members is not consistent. Some societies no longer have the special character of "comparable professional quality," which caused many problems in academic exchange and affect the rapid improvement of the academic standard. Provincial societies issued membership cards according to the "Regulations of Societies" to make some adjustment to the obviously unqualified. But, several items in the regulations are too fundamental. Therefore, it is difficult to control the confusion in membership drives. According to the experience in membership drive in recent years, we should focus on four areas: First, those who have either the required academic credential or the necessary experience are readjusted according to the following requirements as a first point to attack the inconsistency in membership standards:

1. People who have inventions, creations and reforms to their credit, and received recognition from the government or administrative office of the same profession.
2. People who have savored technological imports, contributed to the theory and methods of exploitation of natural resources, and were acknowledged by the leadership and their colleagues.
3. People with more than two academic papers, research reports and technical summaries (with exploratory and academic value) selected by societies, or with an outstanding paper evaluated by a society, or with publication in professional journals.

4. People who introduced new teaching and technical management methods which were adopted by some departments or had promoted teaching and technical management.

5. Similar opinions formulated by a specific trade based on the spirit of the above four items to be implemented with the approval of the Commission of Science and Technology.

We should not be too rigid when we implement these rules so that self-taught, talented people can be continuously supplied to the society without lowering the quality of the membership.

Second, we need a few innovators. The spirit of readjustment is basically the same as above.

Third, Enthusiastic and supportive officials should be readjusted according to the following:

1. Officials who are primarily in charge of technical management and are enthusiastic and supportive.
2. Very few administrative officials limited to the board of directors and special field committees.
3. Other officials must be processed in accordance with item 1.

Fourth a few societies such as abacus calculation, apiculture and sericulture, have been established for several years. The activities brought very good results nationally (especially the abacus calculation society). However, there are relatively few qualified members. In the readjustment, we should primarily focus on accepting group members. However, qualified individuals should still be accepted as individual members.

In order not to affect the enthusiasm of the unqualified, they should be allowed to maintain their membership for 3 to 5 years so that they can catch up. However, they will not be issued membership cards and are not included in the membership statistics.

II. Readjustment of Professional Committees

According to the "Regulations of Societies" professional committees and sub-committees (including the so-called secondary societies are academic organizations under the board of directors of the society; not primary society organizations. In recent years, because of rapid growth, some confusion surfaced among these organizations. There are overlapping members and redundant activities. In organization, they were formed as a primary society. The readjustment of this level of organization is the current focal point.

First, readjustment of the responsibilities of this level of organization. According to the national organization workshop, a secondary organization of the society should be called a professional committee. Its primary functions are: to define a plan of academic activities (approved by the board of directors of the society), to organize the review of academic papers, to conduct academic exchanges, to renew knowledge and to train people, to solicit, review, recommend, edit, and publish academic or popular journals and books, to gather and transmit professional trends and news, to handle inquiry and recommendation of major issues on the development of the field and its impact on the economy, and to strengthen contact with lower level organizations and related societies.

Second, organizational requirements of readjustment.

1. Redundancy of personnel and activity must be consolidated. For instance, the boiler society and the technical safety society of boilers and pressurized vessels in the provincial mechanical engineering society duplicate each other and should be consolidated.

2. When professional organizations are duplicated with different emphases, one of them must be designated as the coordinator. For instance, provincial societies of chemical engineering, military engineering, environment and ecology have an environmental science committee. The environmental science society should coordinate (through the society operations department).

Provincial societies of aerospace, military engineering, metals, railways and ship building have their own materials committees. The society of metals should be the leader in coordination (through the society operations department).

Provincial societies of electrical engineering, energy and railroad have their own energy committees. The society of energy should play the coordinating role (through the society operations department).

Provincial societies of communications, railways, automation, military engineering and aviation have their own automation subcommittees. The society of automation should coordinate all activities (through the society operations department).

Provincial societies of survey, geology, automation, and ship building have their remote sensing subcommittees. The society of automation should be in charge of coordination (through the society operations department).

Provincial societies of petroleum, geology, metallurgy and coal have their subcommittees on geology. The society of geology should be in charge (through the society operations department).

3. Societies of leading edge disciplines in the new technological revolution should be elevated to become primary institutions. For instance, societies of electronics, communications, automation, aerospace and electrical engineering have their own computer subcommittees. In order to meet the challenge of the new technological revolution and to be successful in the four modernizations, we should separate them from the secondary structure and establish a primary society with emphasis on applications.

4. All existing secondary societies shall become subcommittees with appointed board of directors. In order to maintain the enthusiasm about academic activities, for the time being, they may still retain their titles as secondary societies. Problems in readjusting secondary societies in agriculture and medicine may be dealt with on an individual basis.

III. Readjustment of Board of Directors

The board of directors is the leadership of a society. Its composition and operation will affect the success of the society. There are many problems at this level. The term in some societies is too long. There has been no re-election for many years. It is thus difficult for a society to grow. Some board members are too old and their knowledge is out-dated. The society thus lacks vitality. Some board members have too many part time obligations to spend their energy on society affairs. In some cases, there are too many administrators on the board so that the view of scientists cannot be expressed effectively. In a small number of societies, the administrator acted alone to appoint or dismiss the officer of the society without going through the board of directors and the general membership meeting, forming a tendency to replace the mass opinion with politics and the CPC. Some societies become a league of who-is-who in the area and the membership on the board is virtually permanent. The number can only increase but not decrease. The board of directors becomes too cumbersome. Some of the board members do not participate in meetings, which practically paralyzed the board of directors. Therefore, it is urgent to re-adjust the board of directors.

A. Readjust the composition of the board of directors.

1. The board of directors is not an honorary organization. It must demonstrate some academic authority, membership representation and continuity. In addition, it must be compact in structure with enthusiastic directors to maintain the vitality.

2. Candidates for directors must be well established scientists who are enthusiastic about society activities, or top young technical people. Managing officials in technical areas who are enthusiastic about society activities may also be elected.

3. Chairman and vice chairman should, in principle, be given to well recognized scientists in the field who are enthusiastic about society affairs. On an individual basis, if necessary, the leadership may assume these positions according to the rule stated above. However, we must gradually transfer these positions to scientists or part time administrators.

B. Rationally coordinate the age of the board through readjustment.

1. Continuous replenishing of young and middle-aged scientists is the vitality of a society. From now on, every society must formulate rules to select outstanding young people and set up files to train new technical leaders. We must have a reserve to continuously pump new blood into the board of directors.

2. Old scientists have considerable experience in society activities and are emotionally tied to the society. They are technical leaders and treasures of the academic community and the CPC. We should continue utilizing those old authorities who are healthy, knowledgeable and capable of guiding technical work.

3. More than 70 percent of the board members should be young and middle-aged people.

C. Forming a newer stronger but capable board through readjustment.

1. The size of the board should not be too large. It is appropriate to have between 20 to 50 people after the readjustment. The specific number may be determined by the actual number of members. Each society may refer to the following guideline: 20 directors for less than 1,000 members (or less than 20 if the membership is very small) and adding an extra 10 directors for each additional 1,000 members. Candidates receiving less than half of the total votes may become backup directors who will fill any vacancy in the order according to the number of votes received. The term will be 3 years. One half of the directors will be replaced in each term. Each member may not serve more than two consecutive terms. However, one may be elected again after skipping one term.

2. After the readjustment, the executive committee should be held to 5 to 13 people. Each executive director, in principle, should not work for more than two societies.

3. After the readjustment, there will be one chairman, one to three vice chairmen, one secretary and one to three assistant secretaries. The chairman and vice chairmen are, in principle, not supposed to hold similar office in other societies.

The readjustment of the board of directors must be implemented immediately. If it is not possible to hold a general membership meeting, then an election should be held by mail. Societies not meeting the readjustment criteria should further adjust their boards by mail even though they were recently re-elected. An reelection may be held with the prior consent of the commission on science and technology at the same level (15 days in advance) and with advanced consultation with the relevant authorities.

IV. Overall Readjustment of Societies

In regard to the overall readjustment of societies, it was pointed out in the national society workshop that "societies in the provinces, cities and autonomous regions are a part of the national societies. Their adjustment should be done after the national societies are readjusted. It is necessary to coordinate and negotiate in order to avoid discontinuity." In addition, the policy of "minor readjustment" was introduced. Therefore, provincial societies should primarily be prepared for the overall readjustment with the exception of some minor but necessary adjustments.

The readjustment is an active one. Areas should be cut will be cut and growth will also be suitably controlled. As we plan the overall readjustment, we must also consider how to promote technical development. As science is being further divided, the scope of societies, associations and research organizations are becoming narrower. However, the high degree of consolidation of science also requires the integration of science. Therefore, it is necessary to have large scales of exchange among the disciplines to allow cross over and penetration in order to overcome the barriers hindering any further technical development due to fine division of disciplines.

V. Readjustment of Affiliation

With readjustment, many society affiliations will change. For example, the society of agricultural machinery has already been placed under the jurisdiction of the provincial bureau of agricultural machinery and the society of forestry under the bureau of forestry. Many other societies are planning to change their affiliations.

The four basic society readjustment principles must be obeyed when a newly established society is seeking for an affiliation or an existing society is changing its affiliation. In principle, there are several specific requirements: 1. capable of providing a staff, 2. capable of funding the expenses, 3. capable of supplying office space, 4. capable of supplying necessary equipment and creating future development. Societies without a staff, a source of funding, and a supporting affiliation may be managed directly by the Commission of Science and Technology..

12553

CSO: 4008/221

NATIONAL DEVELOPMENTS

ORGANIZATION, MANAGEMENT OF MARINE ACOUSTIC STUDIES

Beijing KEYAN GUANLI [SCIENCE RESEARCH MANAGEMENT] in Chinese No 1,
Jan 85 pp 50-53, 46

[Article by Han Youquan [7281 2589 3123] of the Institute of Acoustics,
Chinese Academy of Sciences: "Organization and Management of Scientific
Investigations on Marine Acoustics"]

[Text] Field investigation is an important part of the entire scientific study program in Chinese Academy of Sciences. It is also significant to the development of science and technology, as well as to various aspects of growth in the nation. The uniqueness of field investigation is that the assigned task is completed more independently away from the guidance of the institute and the academy under difficult situations. Therefore, it is very important to manage the organization well in a field study. This article is focused on introducing the organization and management of a recently completed deep sea acoustic study, hoping to stir up some interest in studying the organization and management of field investigation.

This deep sea acoustic study was conducted in September and October 1983 in the South China Sea. Seven laboratories in the Institute of Acoustics and the Institute of instruments of the Bureau of Oceanography, together with three ocean survey ships, participated in this study. In terms of contents of the investigation, depth of the ocean and number of participants, this study made history in hydroacoustics in China. The difficulties encountered and the hardship caused by gale wind and giant wave were also never experienced before. The preparation took about a year and the field work lasted approximately 2 months and the voyage covered over 2,000 miles. We overcame difficult sea conditions due to typhoon and accomplished the mission. The success of this mission is primarily attributed to strong organization and effective management. In this regard, we put together the management to strengthen the organization, made feasible plans, worked hard to implement the plan, defined specific responsibilities and executed the plan thoroughly with ideology.

Team Management, Healthy Organization

A strong and effective management team is the key to managing a scientific field study. Therefore, the first thing to do is to put together a management team after the assignment is handed down from the superior. This team should be knowledgeable and have the ability to make decisions based on judgement. This team should be highly qualified and have the ability to communicate with people and with other departments. This team should

know the formalities and have the ability to discover and solve business problems. In other words, this team must be an intelligent entity to form a strong and powerful core of collective management. With the support of the management at the Institute of Acoustics, a coordination meeting was held in January 1983 with representatives from all units attending. Through negotiation, an intelligent management team for this scientific field study was created. Furthermore, an academic research fellow and an associate research manager were appointed as the persons responsible for the preparation of this expedition. During the implementation stage, both comrades, together with the assistant captain of the vessels, jointly formed a management team. Thus, the intelligence in academics, management and navigation was combined to ensure smooth progress of the investigation in the ocean.

Feasible Planning

Planning is the center of organization and management in field study. Without a plan, there is no arrangement for manpower, money, materials and time. The implementation of the scientific study is thus nothing but an empty dream. Therefore, the first task of the management team was to formulate a plan for this field investigation. The planning was divided into three levels; overall plan, implementation plan and navigation plan. It includes the purpose of the study, methodology, personnel assignments, progress, timing, and distribution of materials and funds. The overall plan is a rough one which is primarily used in preparation. The implementation plan is the execution of the overall plan in the field. The navigation plan was formulated based on the weather, vessels, personnel and equipment in order to implement the other two plans. This plan is more specific, more concise in assignments, and more accurate in timing. It is the decisive plan, determining the success of the project. Therefore, it must be carefully considered. One slight mistake may ruin the project.

A plan must be feasible because only a feasible plan can produce better results efficiently. Otherwise, either time, manpower, money, or material is wasted. It is necessary to have relevant information in hand in order to formulate a feasible plan. In other words, we must examine all situations to be encountered in the field study and predict all possible consequences. Our plan was not designed by an individual manager in his office. Instead, it was a product of joint discussion between managers and technical personnel based on a great deal of surveys. Therefore, it objectively reflects the reality and thus becomes more practical. This was proven in actual practice.

It should be made clear that it is impossible to have a perfect plan because the problems encountered in a field study could be very complex. There are many influencing factors which are constantly changing with time. For example, the weather, vessels, equipment and personnel are directly affecting the smooth implementation of the plan in a deep sea acoustic study. The entire plan may fall through if one of the factors creates a problem. Undoubtedly, it is impossible to control all factors and keep them unchanged. Therefore, we must leave some room when we formulate the plan. For example, we should have several technical approaches, spare equipment, and flexibility in timing in some key spots. By doing so, we will be able to take counter measures even when serious accidents occur.

Implementation with Full Strength

After a plan is drafted, the most important task of the management is to implement it at full strength. In the implementation process, we must investigate the progress and evaluate the plan itself in order to reveal problems in time to take proper measures to correct impractical items in the plan. This cycle is repeated until the work is done. This implementation process can be expressed by the following simple formula:

planning → implementing → checking → correcting → reimplementing →
..... → success

Implementation of the scientific investigation is the activity of the people to accomplish the mission. As a matter of fact, this is an application of the recognition and mass line in Marxism, which is the first pattern to reflect actual practice.

Situations encountered in a field study may be complicated and varying. The management team must be at the front line to personally experience the condition and to listen to other opinions. They have to react promptly and must be able to judge accurately. Policy making decisions must be made forcefully and measures adopted must be appropriate. Not only are they required to be able to find key points to tackle with, but they also must pay attention to minor details and handle them in time. Only by doing so can success be ensured.

In a marine acoustic field study, experiments have to be made at the ocean. Assuming that there is no human factor involved, we cannot begin our voyage if ships are not secured or are out of order. Even if the survey ships are ready, we still cannot go if the weather is not good. In addition, if key instruments are not in good running conditions, then we still cannot sail. Even if we sail into the survey area, we still cannot accomplish our mission. It is obvious that, in addition to human factors, the equipment, vessel and weather are the three key links in a marine acoustic field survey. Only when all three links are simultaneously satisfied, a marine acoustic field survey can become a reality. One should also realize that there is a series of small links in each large link. For instance, survey vessels include transmitting and receiving vessels which require maintenance, training and preparation. The survey equipment includes transmitting, receiving, recording and auxiliary measuring systems. In the weather area, we are involved with large and small area over long and short-terms. Furthermore, there are finer details in each small link. For example, the transmitting system includes explosive sound source (hydroacoustic signal charge), transducer, cable, winch, transmitter,, etc. These items link together to form a system. A weak link is an area without much strength to develop. Although some weak spots appear to be minor, however, they may have a serious impact on the success of the program.

Our approach is to consider the overall picture and have control over key items and weak links in order to solve any problem which may arise.

Clearly Specifying Responsibilities

As discussed above, there are many managing factors affecting a scientific field survey. The most common factor, without any doubt, is man and his activity. The manager and the managed are all people. The essence of organization and management is to coordinate people's activities. Therefore, it is very important to set up rules and regulations to put these activities on the right track and to establish a good working order.

The most important thing in management is to establish a responsibility system. The management system can only function smoothly when the specific responsibility assigned to each position is unambiguous and non-contradicting. There should be no excuses and attempts to shift the blames to someone else. Excuses reflect the vagueness of the responsibility. To this end, we divided the survey tasks into a series of positions according to the nature and scope of the task. A number of appropriate positions were grouped together on the same ship. All survey vessels formed a convoy. The command center was located on the flag ship. Each ship and every position has assigned responsible people. Moreover, people were assigned to different posts based on their abilities so that they can be fully utilized. Different management levels and posts had different responsibilities and authorities. The load is shared with collaboration. If necessary, the resources can be concentrated to meet an emergency.

The implementation of any responsibility system requires the protection of organizational disciplines. Rewards and punishments must be given accordingly. We had made specific rules and regulations in this area. For the purpose of discussion, several rules announced then are briefly described as follows:

1. A person may express his opinion on the project plan and the implementation plan. Once the plan is finalized, we must rigorously follow it without deviation. When a problem arises, it must be reported timely. One should not take anything for granted.
2. Each position must carefully perform all the necessary preparatory work in time, including calibration of instruments and carrying complete sets of tools and spare parts.
3. Each person must take his job seriously. He must obey orders, concentrate his effort and keep good records in order to ensure the integrity and reliability of the data.
4. All operations on deck, especially in launching the deep charge, must be done according to the manual. Carelessness will not be tolerated.
5. All personnel are encouraged to collaborate with others to form a single entity. Any problem should be reflected through the organization. No private individual opinion is allowed.
6. All personnel must remain calm in special occasions such as bad weather condition, enemy attack and ship failure. No one should leave his post before he is told to do so.

7. All personnel are encouraged to endure hardship, fatigue, sea sickness and sacrifice until the mission is accomplished.

The center of discipline is to ensure uniformity. Therefore, everyone was led by the same driving goal to jointly accomplish the assigned survey mission. In addition, we also noticed that some flexibility could allow people to utilize their talents more effectively. Everyone is allowed to have some freedom in treating problems within his responsibilities in order to encourage creativity.

Thoroughness in Ideology

The essence of organization and management is to coordinate human activities and men have the ability to think. Therefore, political ideology training is an important item in managing a field survey. Among all factors, the human factor and the thoughts of people can have a decisive effect sometimes.

In the field, people's thoughts are always closely connected to the scientific survey. Because of the difference in affiliated unit, location, nature of the job, technical level and selfcultivation in ideology, their thoughts associated with the survey are also different. For instance, comrades from research institutes are inclined to neglect practical problems related to survey ships and overspecify the requirements. Comrades on the survey ship, however, do not have a profound understanding about the objective of the survey and consider the voyage as a burden. Each research unit also attempts to give priority to their own projects. In the presence of difficult situations, some are afraid to tackle the problem, some take it lightly and some cannot care less. When things fail, some are discouraged and some just blame others. Even when things are running smoothly, some tend to be self-content. Scholars tend to scorn each other. Sectarianism may lead to mutual counteractions. If there is difference or contradiction in the ideology, the scientific survey may be affected. Therefore, political ideology education is an important task in any scientific investigation. It will fully mobilize the enthusiasm of the people so that everyone will give priority to the overall project and coordinate his activity with other departments. A new united entity was formed which became one of the accomplishments in this marine acoustic field survey. In this regard, fundamentally the ideology work was carried out from beginning to end with emphasis on three stages, i.e. mobilization at the beginning, encouragement in the field, and summarization at the end.

Mobilization at the start was to hold a general meeting to explain the goals and objectives of this survey, to introduce the procedures of this project, to assign responsibilities and to announce rules and regulations when all the participants arrived. Through mobilization and discussion, we had unified goal, ideology, plan and action which served as a solid ideological basis for the success of this survey.

On-site encouragement in a field survey is to combine general appeals with real actions in every possible opportunity by using various means in order to push the entire survey toward success.

Summarization of the survey is to hold a review meeting immediately after the completion of the mission in order to solidify existing accomplishments. This is to avoid an emotional letdown after the successful completion of the mission so that all follow-up work can be done in an orderly manner. We adopted a collective mass summary approach. First, everyone was invited to talk about his experience and lessons learned from failures in the survey, the good and bad things about the trip, his evaluation of the survey and his opinions and suggestions to the leadership. Then, based on opinions gathered, the management team prepared a summary by adding their own experience. This is better than having the manager writing his own summary. It is easier to locate the lessons learned and good people could be rewarded with public recognition. It is also possible to objectively evaluate the results of the survey. The summarization process is a recognition process so that "we may summarize the experience to meet the next round."

Because of our continuous outstanding ideology work, we were able to turn mutual blame to forgiveness when we encountered some problems, especially when the first voyage was unsuccessful and the transmitting ship broke down. Every time we were in a difficult situation, especially when a ship could not be fixed on the spot, the backup ship could not be secured and the weather condition turned worse, we were able to firmly proceed forward. In every urgent moment, especially when the backup ship was delayed, the number of good weather days was limited and the weather condition in the return voyage was stormy, we were able to conquer the danger and insisted on moving on to accomplish the mission. On the way back home, we were sandwiched between a cold front and a typhoon. We managed to overcome sea sickness, fatigue and hunger to bring the victory home.

In summary, the organization and management work is essential to the successful completion of a field survey trip. In other words, without scientific organization and management there is no scientific accomplishment in a field survey. The management standard will, to a large extent, affect the final outcome. Therefore, it should be examined in depth in the study of research management. Especially in the middle of reforms in China, whether a field survey should be handled as a contract to closely connect the completion of the project to the personal gain of the technical staff is a new worthwhile research topic.

12553
CSO: 4008/221

NATIONAL DEVELOPMENTS

SCIENCE AND TECHNOLOGY REFORMS DISCUSSED

Beijing LIAOWANG OUTLOOK in Chinese No 12, 25 Mar 85 pp 9-10

[Article by Ga Mainan [7357 6701 0589] and Zhuo Peirong [0587 1014 283]]

[Text] One day in March we interviewed the director of the State Scientific and Technological Commission, Song Jian, on the question of the reform of the science and technology system.

This famous 53-year-old scientist in cybernetics is also a brilliant space engineering specialist, professor and research fellow. He studied in the Soviet Union in his early years. He was a graduate student under Professor Fuliete Baomu [Phonetic], who is a well-known cyberneticist. When he was only a graduate student he taught a specialized course called "modern cybernetics" to Russian students and students studying in the Soviet Union from other countries. He became one of the few Chinese who have taught in a Soviet University. After he returned to his own country in the early sixties, he engaged in research work in guided missiles for over 20 years. He was in charge of the overall design of the control system for our country's first generation of ground-to-air missiles. He has played a very important role in the work of designing and testing the launching of guided missiles under water, testing the communications satellite of our country, solving key problems in technology, etc. His contributions in the area of optimizing control and partial differential equation control systems and population control theories have won world-wide acclaim in scientific circles. There are many of his peers in scientific circles who admire Song Jian's talent and consider him one of the authoritative persons in cybernetics in our time. Many stories about his selfless work have spread far and wide among our country's science and technology circles. At the moment he is conscientiously leading the work of reforming China's science and technology system.

"You have been directing the work of the State Scientific and Technological Commission for more than half a year. In your opinion, what is the situation of the science and technology reforms?"

Song Jian, speaking the common speech with a Shandong accent, smiled and said: "Since working for the State Science and Technological Commission, we have started an investigation, and I have also been to several research institutes. The facts prove that when research institutes have the freedom to reform they all grow and flourish. Their work is much more efficient than

before, and their research findings have increased many times. The incomes of the research institutes and the welfare of the staff are all much better than in times when people depended on the 'supply system.' Those science and technology personnel who were wise and talented were discovered in no time by the workers and cadres. The ones who drifted aimlessly around are no longer doing that. Since 1983, our whole country has had over 600 independent research organizations who have undergone experimental reforms. The results of these experiments indicate that the reforms have a good future."

"Why must our present science and technology system be reformed?"

Song Jian thought for a while and said: "In order to accomplish the four modernizations we must reform our present science and technology system. Because our present system is mainly a closed-shop system for each profession, the professions are out of touch with society and the economy. The final goal for science and technology is to change nature and develop the social economy. From this point of view we must set up a new system which is geared to the needs of the economy and society." At this point he gave an example. "In our country we have a science and technology contingent of more than 10 million persons, which means enormous potential. Everybody gives heat and light. Just like the principle of the rocket engine, we need to design an instrument like an air-jet pipe which can concentrate all this energy so that it can be launched in one direction. The present science and technology reform in which we are engaged is just like designing a projector: the goal is to make the creativity and initiative of the science and technology personnel concentrate on the magnificent goal of quadrupling the national economy by the end of the century."

"Can you say a few words about your understanding of the policy, which was brought out by the party and state, that science and technology must be geared to the needs of our economy?"

"For the past few years our country's economic situation has been very good. Especially in 1984 the growth rate of the gross value of industrial and agricultural production is higher than 14 percent, surpassing 1 trillion Yuan. But we should not forget that if we divide this by 1 billion people, the per-capita gross national product is still less than U.S. \$400. Our country is still a country with a low income among those in the whole world. We rank 20th from the bottom among 126 countries. There are a lot of science and technology people who hope that the government will give them enough funds for their research work, but under the present economic situation the government finds it impossible to allocate large funds to all the professions and specialized trades. Therefore, the party and the people naturally ask the science and technology personnel to face the economic arrangement and ask them to make the achievement of the objective of quadrupling the production their central task. The government can only give more support to those long-term research projects after the economy has developed, the society's esteem has increased and the country's actual strength has strengthened. In short, as Comrade Hu Yao-bang puts it: "If the country's actual strength enhanced and the economy cannot grow, then everything will be empty talk."

"Can you tell us what key measures will be adopted in the reform which will be carried out soon? And why these measures should be adopted?"

"According to my understanding there are four key reforms: (1) to open the technical market, (2) to change the allocation system, (3) to strengthen the ability of the enterprises to absorb and develop the new technology and (4) to train a large number of young and middle-age leading key members in science and technology who have both greater academic achievements and open minds for development. Among these four, the first two are the ones which will point the direction toward system reform. What does it mean to open the technical market? Previously the scientific findings of the research institutes were assigned without being paid for. The method often developed is the tendency of "everybody eating from the same big pot." Hereafter, this old system should be changed into the system of contracted work with payment. The technological findings can be used as capital to invest in enterprises, can be sold in the technical markets and can also gain foreign exchange. In short, we should open all the doors of technical circulation, make advanced technology and knowledge flow to enterprises and to rural areas from the research units, colleges and universities in a steady stream and bring along the progress of enterprises in order to give impetus to the development of the enterprises to the rural areas, small towns and villages and to accelerate the development of inland and outlying districts. At the same time, the scientific organizations and science and technology personnel will get the respect and rewards which they deserve from society in the process of popularizing and spreading knowledge.

"The second big reform is that the state (including government organizations at all levels) must change their allocation methods. The operating expenses will be decreased each year for those research organizations which are the technical pioneer types. The operating expenses which will be saved and the scientific research expenses which will be increased each year will be given according to the task which they have contracted. For those science and technology personnel who are not given assignments, they will be encouraged to go out to enterprises, to their localities, to society and to the market to find jobs. Doing it this way will mean that tens of thousands of people will be able to help in society, in the enterprises and in the economy. This is a large force. Often one engineer can save an enterprise, and one product can make an enterprise grow and flourish. An even more important result is that often these technologists come out spreading knowledge, especially scientific knowledge on a large scale, which will be beneficial to the whole society."

At this point, Song Jian emphasized: "To the technicians who played an important role in promoting the development of technology and the economy, the government and society should give them full praise, even though they are not number one in the world or within the whole country, but they should get encouragement as long as they have achieved great economic and beneficial results. Last year, the State Council promulgated the rewarding regulation for technological progress just for this purpose. Surely, we should reward the world's number one even more. At present, our country is still short of qualified people who can devote themselves to developing the technical markets. From now on, we should train a large number of these kinds of capable people.

They are the ones who can link research organizations to the economy, the market and the society. We should put those outstanding market development people in an important position and give them a handsome reward."

"Some scientists worry about whether it will again be the common practice to treat all scientific research, such as basic research and applied research, as commodities which will serve the marketplace and be judged according to economic value. And of the scientific research which at present cannot realize economic benefits, or those researchers who at the moment have not discovered anything which can be brought to market to sell, can they still get government support? Would the government stop supporting them or reduce its support?"

"In the reform we must firmly avoid this kind of deviation. Even judged from the point of view of pragmatism, the basic research should not be treated as work which is not essential or aid that comes too slow to be of any help. Luxun once said that science is a sacred light which is shining over the world and which also can prevent wicked influences and enlighten people's hearts. Comrade Yao-bang also said: Science is the holy water which irrigates mankind's happiness. Neglect the value of science and it will undoubtedly lead to mistakes in both philosophy and politics. So when carrying out the system reform, we should differentiate the different types of research work, deal with different things in different ways, definitely not rush headlong into mass actions and not be distracted from the correct policy."

"What measures will be adopted to avoid similar mistakes?"

"In order to prevent this kind of deviation, to let the reform carry on soundly, solid regulations have already been issued. For example, we must adopt ways to deal with different things differently in order to reform our allocation system; the industry's venture research organizations should prepare gradually to practice contract systems with payment, gradually abolishing operating expenses; to those science and technology service departments, including the scientific service departments such as meteorology, metrology, information, environment protection, health, family planning, etc., the state will continuously allocate their operating expenses, will still give allocations to support the basic research and will increase the allocations each year. But in order to change the situation where there is low productivity and stagnation, where research units have everybody eating from the same big pot and are overstaffed or where they have duplicate jobs, the state will set up a natural science foundation. The science and technology people who are engaged in basic research can bring their applications for expenses there, and then the foundation will organize their peers to evaluate their work and choose the better ones to support and distribute their funds. We encourage basic research to face the practical, the forward position and the world. We encourage researchers to have their achievements contested on the international stage, compete for the gold medal, win honors for our country and bring benefits to mankind.

"Would this system reform encourage qualified people to move from place to place?"

"The party's policy on this subject is clear and definite. The science and technology personnel will be encouraged to move to areas and units where qualified people are badly needed. Whoever moves to the third line, to outlying districts, to areas inhabited by ethnic minorities and to rural areas and small and mid-size enterprises should all be considered as going in the right direction. The construction of the four modernizations is a change with great historical meaning for social production and lifestyles. Without qualified people who can carry advanced scientific knowledge from place to place, it is very difficult to achieve success.

12936

CSO: 4008/319

NATIONAL DEVELOPMENTS

LIAONING GOVERNOR ON USE OF IMPORTED TECHNOLOGY

OW050853 Beijing XINHUA in English 0714 GMT 5 Jun 85

[Text] Shenyang, 5 Jun (XINHUA)--Liaoning provincial officials plan to use more imported technology to renovate existing enterprises, Governor Quan Shuren said here today. He pointed out that most of the province's 17,000 enterprises were built in the 1950s and '60s. The equipment and technological processes are backward. The technical transformation of the existing enterprises is crucial to achieving the goal of quadrupling the production by the turn of this century, the governor said.

According to an initial plan, more than 28.2 billion yuan of investment will be needed for updating technology during the next 5 years. Apart from the funds from the state and raised by the province itself, the province will have to need U.S.\$2.8 billion of foreign exchange to import technology. Priority areas for the import of new technology will be the provincial capital of Shenyang and the open coastal city, Dalian.

Dalian authorities have more than 400 technical import schemes planned for this year, including an oil refinery with an annual capacity of 10 million tons.

Quan said that during the Seventh Five-Year Plan (1986-1990), the province would upgrade the machinery, electronics, iron and steel, petrochemicals and building materials industries. Industrial output value is expected to increase at an annual rate of 8 percent over the period, to reach 90.3 billion yuan by 1990.

Last year, the province spent U.S.\$443 million on importing technology and equipment for 818 development schemes--1.6 times as much as the total for the previous 5 years. As a result, 170 new textile plants have gone into operation, with an expected additional output value of 230 million yuan a year.

The garment industry has imported 8,300 machines over the past few years, and has increased its export value from U.S.\$12 million in 1978 to 80 million now--more than 10 percent of the country's total.

CSO: 4010/2004

NATIONAL DEVELOPMENTS

IMPORTANCE OF IMPORTED TALENT DISCUSSED

Hefei ANHUI RIBAO in Chinese 27 Mar 85 p 2

[Article by Yan Jie [0917 3381]: "It Is Necessary To Place Emphasis on Imported Talent"]

[Text] Imported equipment is "hardware," imported techniques and "software" and imported talent is "liveware." The key is to import "liveware" without spending any money. In importing scientific and technological talent, we can have the multipurpose benefits of using foreign capital, importing techniques, importing key equipment and training capable people. Zhao Jianfang, an American Chinese and a professor in the computer science department at the University of the District of Columbia who had attended a high school in Lin Quan in our province, has a deep feeling for our province. In August 1979, he used one of his sabbaticals, which he has once every 7 years, to come back to our country and at his own expense, teach at Hegong University for a year. He suggested that the university set up an applied microcomputer research center and also worked out a 3-year training program. Since 1981, Zhao Jianfang has traveled between the United States and China, helped our country import advance technical equipment, invited 11 specialists from the United States to come to Hegong University to give lectures and join scientific activities and trained 800 professional and technically able persons at the high, middle and elementary levels. Besides these, he also helped Hegong University set up a microcomputer lab with all the necessary facilities, making it among the first rate in our country.

In recent years, our province has accomplished a lot in terms of importing resourceful and talented people and has obtained results. World-famous specialists and scholars, Yang Zhenmin, Li Zhengdao, Ding Zhaozhong and others, have been to our province at our invitation to give lectures and to open up technical exchange activities. There are also other foreign specialists and scholars who are working industriously on the frontline of scientific education and who have contributed their skills to training the capable people in our province. But generally speaking, our province still has a weak link in this aspect. We have to emancipate our minds further and adopt even more favorable conditions and flexible methods and quicken our pace of importing resourceful and talented people. For example, we can invite some "foreign specialists" and "foreign scholars" to be factory heads, managers and school presidents. We can invite qualified personnel from

overseas to give lectures, to give short-term training courses and to teach science and technology. We can also make friends overseas and invite them to be our "information personnel," let them give us international commercial information and advanced technological data, etc.

While importing talent, we should focus on developing intellectual resources among overseas Chinese and Chinese who are abroad. Our province has more than 14,000 people and overseas Chinese scattered in 60 countries and regions in the world. We have more than 20,000 fellow countrymen in Hong Kong and Macao. According to our tentative estimates there are 1,000 of them who have political power, economic strength and academic attainments. We should nurture the national feelings of these countrymen and overseas Chinese in Hong Kong and Macao to "love ardently their country and to want to rebuild it." We have to create good conditions to attract them to come run our enterprises, both private ones and partnerships, schools and open stores and let them do all that will help develop China and build Anhui.

12936

CSO: 4008/317

NATIONAL DEVELOPMENTS

APPLIED TECHNOLOGY TO ACCELERATE ECONOMIC GROWTH

Hefei ANHUI RIBAO in Chinese 27 Mar 85 p 3

[Article by Xuan Fenghua [1357 1144 5478]]

[Text] Presently, we still have a lot of problems in terms of concepts, systems and policies for applied technology. The key is that we have to set up a science and technology ecology environment with flexibility, versatility and creativity which can absorb, digest, apply and extend the new and developing techniques.

Applied scientific technology is a strategic resource and can accelerate the achievement of the objective of quadrupling the gross value of industrial and agricultural production by the end of this century. But at present, we still have a lot of problems in terms of concepts, systems and policies. For example, in understanding the overall aspect of scientific development, a lot of colleges and universities emphasize the basic sciences and neglect the applied sciences, the scientific departments are separated from production departments and with each jealously guarded, the scientific research subjects are chosen on the basis of theory, not from the practical needs of the production department. This causes a lot of research findings to lose contact with reality and lack extensive practical values. When their scientific and technical personnel are evaluated as to their rank and promotion, they are judged by the number of theses they have written, not evaluated on the practical beneficial results they have contributed to the community. They emphasize theory, not practice. This situation has forced a lot of workers who have worked in applied science and technology to give up their practical research and dig into books to write articles. This also to a certain degree has blocked the development and extension of applied science and technology. Although there are a lot of scientific research subjects and findings with applied values, for long periods they stay at the experimental stage and nobody cares about the practical application, which can be accomplished only by tests. They lack a bridge and middle link between science and technological findings and the production department. With the lack of information, science and technological findings cannot be quickly changed into factory goods and economic benefits. This results in the factory being unable to get the techniques they need badly, and the scientists and technicians are unable to get their scientific and technological findings applied. The factories have the attitude that since everybody is eating

from the same big pot which is supplied by the state, no matter what one does one will get the same treatment and allowances made for losses. This builds a reliance on allocations and stifles motivation and initiative in developing new products and techniques. All these present a big obstacle to the development of applied science and technology in our country.

The new technological revolution which engulfed the entire world at this time has brought about a severe challenge to our country's economic power, labor productivity rates, knowledge, concepts and administrative systems, and at the same time it has also presented us a good opportunity for development. Here the key is that we have to set up a science and technology environment with flexibility, versatility and creativity, which can absorb, digest, apply and develop the new and developing techniques. Because of this, we should adopt some corresponding measures and policies and set up new and necessary social connections. For example, (1) in our country's overall scientific development plan, we should focus on the development of applied science and technology and also begin to look practically at the economic, industrial and mining enterprises. (2) We should break the boundaries which are being heavily protected by scientific departments and production departments. We should link these two departments together, closely and extensively. We should make the scientific research subjects come from production experience and the research findings can be feedbacks to the production process. An applied project cannot be considered completed if it does not translate into production and benefits. (3) When scientists and technicians have successful experiments and economically beneficial findings, these successes should also be used as a basis for rank, promotion and reward evaluations. We have to create a new concept which emphasizes relevance, practicality and benefits for the whole country. (4) We should set up a network for cooperation and the exchange of applied technology throughout the whole country. We should break barriers among individual units and in the system of ownership of departments. We have to strengthen the network of relationships criss-crossing departments, disciplines and professions in order to form a lively situation which consists of technological cooperation between the coast and inland, central cities and small towns, among the universities, colleges, research institutes, industries and mining enterprises and also among talented people and lets the movement of information flow freely. (5) We should extensively learn about new techniques, new equipment and new materials, pay special attention to those already proven and use the more effective technology, putting the emphasis on assimilation, application and expansion.

Use our intelligence to bring economic benefits, use our intelligence to promote quadrupling the goal and let applied technology be an accelerator for our country's economy. March forward!

12936
CSO: 4008/317

NATIONAL DEVELOPMENTS

SUCCESS OF TECHNICAL MARKETS SEEN IN CIRCULATING COMMODITIES

Wuhan HUBEI RIBAO in Chinese 2 Apr 85 p 2

[Article by Liu Qinglin [0491 1987 2651]: "It Is Necessary To Stimulate the Circulation of the Technical Markets"]

[Text] The technical findings and applied technologies already regarded as commodities of intellectual creation have already broken down all kinds of outworn concepts, have in a stately manner entered the circulation system, have integrated with the economy and have played a more and more important role. To be suited to this, the technical markets emerged as the times have required and supplied a wide stage for intellectual commodities. How can we make the play more vivid and dramatic and make it full of power and grandeur with the opening curtain of opportunity.

This reporter believes that an intellectual commodity is the same as a material commodity. Both need to be circulated, and when the circulation is enlivened, this most lively singing group of intellectual commodities presents a most colorful and different characteristic style drama.

Now the problem is that the crucial part of our original science and technology system, which is the circulating link of technology, is not yet open and its sale rate of technological findings is very low, so there are a lot of technological discoveries which still cannot get on the stage to do the show on time. Take only Wuhan as an example. Before 1981 the scientific and technological discoveries coming from the colleges, universities and scientific research institutes of the Wuhan area were only 10 percent. Although the situation has improved over the past year, the usage rate is still less than 60 percent. This means that almost half of the technical commodities still did not get into the circulation system. Therefore, dredging the circulating links in the technical markets has become an important problem which demands a prompt solution.

How can we get the technical markets circulating?

First, we must take the further step of breaking up the ownership of the technological findings owned by departments and institutes, organize an open and transregional network for the technical markets and technical information and let the technical commodities enter the circulation system as soon

as possible. In the past, for a long time, because of the yoke of the old science and technology system and the division between scientific research and production, there were a lot of technological discoveries which stayed at the show stage or as a sample and could not be turned into a product. The enterprises, because of the two "big pots" did not work hard enough to absorb the new technology and develop new products. Our scientific researchers are still in an unrealistic state, and they are often satisfied with the discovery and with writing their articles. They do not think in terms of making their discoveries into useful products. They are really helpless to do anything with it. On the other hand, scientific research and production are unconnected. This causes the technical information which the enterprises urgently need not be passed through to the scientific research units on time, and thus it seriously blocks the development of new techniques. Therefore, to organize the new network for technical markets and information and to accelerate the circulation of technical commodities seem very obvious. Wuhan, located at the center of China and concentrating on learning, has 28 colleges and universities, 224 scientific research institutes and design units and 143,000 scientific and technological personnel and is a rich collection and distribution center for the knowledge industry, and also with numerous scientific research institutes which are in advance of others, it possesses a strong appeal and influence throughout the country. To set up Wuhan as a technical market center of China, catering to the whole country, is not only possible but also feasible.

Second, to enliven the circulation of the technical market, we must transform the selling market into the buying market. Marx once pointed out, when discussing circulating commodities, that "there is a very stupid doctrine: the circulation of commodities will naturally create a balance between buying and selling, because every seller is a buyer at the same time, and it's the same the other way around. This kind of doctrine tries to prove that the seller will bring the buyer to the market." ("Das Capital," vol 1, p 132) We cannot repeat this doctrine; we have to open up technical markets boldly and transfer intellectual commodities into practical productive forces. Besides extensively developing multi-level, multi-form and multi-channel technical trade activity, we have to increase the enterprises' ability to absorb technology and to digest the technology; otherwise, we have only sellers and no buyers, and talk of circulating intellectual commodities will be empty. Following the in-depth development of the reform of the economic system, the competition among the enterprises will become increasingly acute, and the demand for science and technology more urgent day by day. But some enterprises which need the technology often cannot afford to buy the technological discoveries because they are short of capital. They can only bemoan their inadequacies in the face of a great task. In order to solve this problem, Wuhan's municipal scientific committee from three kinds of science and technology operating funds allocated 500,000 yuan to set up a developing fund for science and technology to help the medium-size and small factories and the small-town enterprises to apply new technologies to create new products. But this is still an utterly inadequate measure, and it is hard to meet the needs of the large number of enterprises for technical commodities. If we want to solve this problem fundamentally, we still need economic levers and marketing adjustments to play important roles, and we also have to carry out

preferential policies in terms of tax revenues, granting loans and expanding the use of new techniques. Besides, we should readjust the organization of the science and technology system to encourage the scientific design units and the colleges and schools to set up all kinds of joint bodies with enterprises which are centered on programs for developing local professionals and on plans for transforming technology by combining science and business. For enterprises, we should consider enterprises that rely on technical improvements and raising economic benefits as important targets for consideration and supervise the application and development of new techniques.

Third, the intellectual commodities cannot market themselves. Therefore, the key to enliven market circulation is that we must train contingents of creative administrative personnel who understand technology and are good at managerial work. An intellectual commodity is different from a material commodity, and the buyers can tell by looking at it whether it is good or bad, or they can discover the quality when they use it right away. The quality of an intellectual commodity can be appraised only by experts, otherwise the phenomenon of low-quality production assignments will appear with the result that a lot of enterprises will compete for its production, causing a waste of manpower, material and financial resources. Therefore, the active "middleman" in the technical market must be a science and technology person who has expertise. Judged from the present situation, there are very few of these kinds of people, and their social status is very low. The concept that "all merchants are unscrupulous" is deeply rooted. The old thinking which despises management blocks this kind of talent from emerging. According to investigations, among the comrades who work at scientific research institutes at the colleges and universities, almost none can keep their minds on their work. As for those who are very fond of management, they are almost non-existent. Because of the shortage of middlemen, some of the intellectual commodities often cannot get into the circulation system and the technical information from the outside also cannot be passed on to scientific research institutes. Thus the circulation gets blocked. So at the present time, we must raise the status of these special managers, not only to create better conditions for their work but also to adopt a measure to raise their managerial capabilities and to make them keep their minds on their work conscientiously as good "middlemen" in order to help develop the circulation for the technical market.

12936

CSO: 4008/317

NATIONAL DEVELOPMENTS

VIEWS ON REFORMING SYSTEM FOR TRAINING DOCTORATES

Beijing GUANGMING RIBAO in Chinese 5 Apr 85 p 4

[Text] At present the focus of our training program for postgraduates is on the masters program. We have very few postgraduates who are studying for the doctorate. This is harmful to our program of training capable persons to promote the development of our country's science and technology. To change this kind of present situation, I think we need to carry out reforms in these areas:

1. We should focus on training doctoral candidates by adopting a flexible system for the postgraduates of science and engineering. Beginning graduate students who show potential after they have taken some courses and done some initial practical work can study directly for their doctorate by not writing their master's thesis, not taking the master's degrees, or not being tested again. By doing this they can accomplish their research work without any interruption or letup, can achieve more in scientific research, and reach a higher academic level.

The United State's system of training graduates is comparatively more flexible. Most graduates study for the doctor's degree directly. They do not go through the master's stage, they go into lab work once they are admitted to a school, and they take courses and do research work at the same time. The student's ability for working independently, for analyzing and resolving problems is mainly gained through the large amount of research work they do, and many research achievements have been accomplished by graduate students.

At present the focus of our country is on training a large number of master degree students. Only a small number of people can get into the doctoral program after they finish their master's program. While working on their masters, they concentrate on their course work and research work consists of slightly more than a year. Within this short period, the only thing they can do is to follow their advisor's guidance and the guidelines designed by their teachers, and use existing facilities to do experiments. By the time they get to the core of their research problem and develop ideas of their own, and with a little more hard work could achieve better results, they have to hurriedly finish their thesis and leave their research half done. If our main task is to train doctoral

students, then doctoral students have to find ways to finish their work based on their own thinking without letup, in order to achieve results in scientific research. This will be very helpful in training capable researchers and making more contributions to the four modernizations construction.

2. Adopt various teaching systems. In addition to the present advisory system, we can also adopt an advisory unit system. In the university, each department will be the unit, in research institutes each discipline or each laboratory can be the unit. The selection of an advisory unit for the graduate student can be based on the quality and quantity of the published works of each unit's professors, assistant professors, lecturers or researchers, associate researchers, and assistant researchers to see which unit has persons who have the ability to guide and train the students to write their doctoral thesis, and the credentials committee can confer on these units the status of training doctoral students. In this way, we can enable all scientific researchers, who have high academic qualifications at present and who have made a large number of contributions to scientific research on the frontline, to guide the doctorate students regardless of age and record of service. This measure can bring a large number of capable middle age and younger teachers who are by no means inferior to their foreign counterparts to work at the forefront. This measure can also improve the present situation in which we have old and inadequate number of teachers who can lead our graduate students. Only after we drastically reform the formula for advisors can we train the higher caliber persons in scientific research in greater, faster, better, and more economical ways, and satisfy the needs of accelerated construction.

3. Combine departments and institutes to guarantee quality. Combine relevant departments in the university or the graduate school and the correspondent graduate institutes and jointly take responsibility for graduate training programs. Graduate students must take required courses at the relevant university first because of the complete range of subjects and experienced teachers available. Students can be well trained in basic and specialized courses. They can lay a good foundation for students to scale heights in science later; at the same time, the students can take relevant courses outside the department as elective courses. For example, graduates in the chemistry department can take solid-state physics, fluid mechanics, biochemistry, computational mathematics, computer science, etc., as elective courses. In this way students can obtain broader knowledge which will help them in their later development. After they finish their courses in the university, they can write their thesis either in the university or in their research institute. In this way, students can use the superiority of the research institutes to write a quality thesis, and can get excellent scientific research results.

A strict examination system must be set up to check the course achievements and thesis of graduate students. A proper ratio must be provided between basic and specialized courses required and elective courses; standards must be established for test results to strictly administer the schools enrollment. An examining group which includes specialists from outside

of the department will help control the quality of the thesis. This not only checks the students but also checks the teachers.

4. Set up a democratic relationship between the students and teachers. While we are increasing the number of graduates and advisers, we must insist that both students and teachers have higher standards. When teachers discover the student cannot meet the requirements of the doctoral study in theoretical or lab techniques or has bad study attitudes, etc., then the teacher can allow him to finish only the master's thesis or transfer him to another department. When students discover their teacher's level cannot satisfy their needs or when the student is not interested in the thesis subject, he can apply to change teacher or subject. As for those teachers who are not responsible or incompetent, the higher academic committee can prevent them from guiding graduate students.

In short, only by doing it this way can the graduate system have abundant vitality, train more doctorate students, and achieve better results.

12936
CSO: 4008/318

NATIONAL DEVELOPMENTS

APPLY ECONOMIC LEVER TO PROMOTE SCIENTIFIC PROGRESS

Beijing RENMIN RIBAO in Chinese 10 Apr 85 p 3

[Text] The decision on the reform of the science and technology system made by the Central Committee of the Communist Party of China has pointed the way for reform of the science and technology system. To put this decision into effect we must do a tremendous amount of hard painstaking work, step by step trying to find out and learn the new working methods which we were not familiar with in the past, such as how to use the economic lever to promote scientific progress.

First, we have to change the source of income of scientific research organizations. In the past, the state basically practices "the supply system" in regard to the scientific research institutions. The amount of expenditure of the scientific research institutes was not directly linked to the jobs they undertook. The scientific research institutes were responsible only to their immediate superiors. Many institutes only look for subjects according to the so-called "mission-oriented task" which is designated by their immediate superiors, and are not concerned with the role of their research results in production. "The decision" offered proposals to change methods of allocation. A large number of technical developments and applied research that is of practical value in the near future will get their funding mainly from contract work and the transfer of research results. Scientific research institutes should constantly make technical results for production needs to create the income to maintain and develop their research work, to improve their staff's working and living conditions. Otherwise, there will be no way out.

Changes in allocation will fundamentally put pressure on the scientific research institutes and the production departments to work together and inject vitality into them. At the same time, scientific research institutes and production departments will forge closer links, they will create one new organizational form out of two. At present nearly half of the 9,000 research organizations in China are independent of businesses and schools. They have more than 80 percent of the total science and technology personnel and better research methods, they are the main part of our science and technology strength. On the other hand, plants and quite a large number of big and midsize enterprises that are the mainstay of our production

departments don't have the relevant research organization and strength, and lack the ability to develop new products. This is our big difference with developed countries. In the United States and Japan, 90 percent of the research organizations belong to business. Our organizational system causes the separation of research and production, thus research institutes do not understand the needs of business and business does not understand the function of technological research. Research institutes and factory enterprises belong to different departments responsible for their work so for research results to be transformed into production goods takes a round-about course. The "decision" proposed that from now on the organizational structure of the scientific and technological systems be readjusted to encourage research, education, the unity of the planning organization and production units, to strengthen the technical development capability of enterprises. To put "the decision" into effect to gradually change the separation of research institutes and enterprises, and to set up a large number of new unified systems, will be a trend which should not be stopped.

Along with the change of the allocation system and the link between scientific research and production, the need for management in scientific research will also have to change. In the past, the state mainly adopted administrative methods of controlling scientific research institutes, the higher level departments had too much control and were inflexible in regard to the scientific research institutes: the expenditures were allocated from higher levels to lower levels, the personnel were assigned by the higher level, the findings were controlled by the higher level. According to the "decision," the management by government organizations of scientific research institutes will be improved, excessive interference by administrative departments will be decreased, the decision-making rights of research institutes will be expanded. This will allow scientific research institutes to set up an extensive and direct relationship with society and production enterprises of their choice and according to production and technological market needs, work out their own scientific research programs and plans, select their own research subjects, allocate manpower, plan expenditure, become an independent research and development body outside of administrative control, and play a dynamic role in the service of economic construction.

Applying the economic lever to promote the care of scientific and technological work, is to open technical markets energetically, and commercialize technology. This will be an extensive place for the exchange of information and technology between scientific research institutes and business. It will break the yoke of administrative rules and regulations of the past, and enable technology to get into the right track of the national economic market, and thus change the situation of the past in which the scientific research institutes have relied on administrative guidelines and directives, and by market adjustment, change the scientific research institutes into an organism which will be closely linked with commonplace production and filled with life. This will also progressively change the situation in which intellectuals cannot get respect and scientific technological achievements are considered worthless, and progressively create a good social habit of respect for knowledge and scientific technology. The scientific research institutes can sell their findings in technological markets, contract to

do the job, get paid for their labor, and then use the payment to develop their research, to reward their scientists, to practice and carry out the principle of getting more by doing more. This will increase even more motivation and energy toward economic construction, and through the economic tie, link the fate of scientific research institutes and production departments.

12936

CSO: 4008/318

NATIONAL DEVELOPMENTS

SICHUAN HOLDS CONFERENCE ON SCIENCE, TECHNOLOGY

HK270912 Chengdu Sichuan Provincial Service in Mandarin 0030 GMT 26 Apr 85

[Text] At the provincial conference on science and technology, Jiang Minkuan, deputy secretary of the provincial CPC committee and provincial vice governor, pointed out that the key to reforming the scientific and technological system is that we must implement the principle that economic construction must depend on science and technology and science and technology must cater to economic construction, and we must use economic levers and market regulation to promote the integration of science and technology with economic construction, invigorate research institutions, bring into full play the initiative and creativity of scientific research personnel, and serve economic construction.

Comrade Jiang Minkuan pointed out that in accordance with the spirit of the central decision on reform of the scientific and technological system and with the province's reality, we must now grasp reforms mainly in the following:

1. We must promote technology to move toward large-scale production and vigorously open up technological market.
2. We must reform the system of allocating scientific and technological funds, give more decisionmaking power to research institutes, and establish a dynamic scientific and technological research system closely associated with economic construction.
3. We must strengthen the abilities of enterprises to absorb and exploit technology, and promote technological progress of enterprises so that enterprises can gradually transform and develop themselves, absorb the newest contemporary scientific and technological achievements, and continuously create new productive force.
4. We must reform the rural scientific and technological system and establish a new rural scientific and technological system suited to large-scale commodity production.

5. We must reform the scientific and technological personnel management system and bring into full play the role of scientific and technological personnel.

The conference lasted 6 days. At yesterday's closing ceremony, leading comrades of the provincial CPC committee, the provincial advisory committee, the provincial people's congress, the provincial government, and the provincial CPPCC committee met all delegates attending the conference.

Provincial CPC Committee Secretary Yang Rudai delivered a speech.

At the conclusion of the conference, the provincial leaders awarded prizes to the excellent scientific and technological achievements which the province made in 1984.

CSO: 4008/2004

NATIONAL DEVELOPMENTS

ANHUI'S HUANG HUANG SPEAKS ON S&T WORK

OW310455 Hefei ANHUI RIBAO in Chinese 16 May 85 p 1

[Excerpts] A 4-day provincial meeting on S&T work concluded successfully on the afternoon of 15 May at the Changjiang Theater.

Attending the closing ceremony were leading comrades from the provincial party committee and the provincial government including Huang Huang, Lu Rongjing, Meng Fulin, Liu Guangcai, Niu Xiaomei, Zhao Baoxing, Hong Qingyuan, Su Hua, Yang Jike, Sun Zongrong, Li Qingquan, Wang Zenong, and Zheng Jiaqi. Huang Huang, secretary of the provincial party committee, spoke at the meeting.

In his speech, Comrade Huang Huang analyzed the situation of economic work and economic structural reform in the province. He said: Since the beginning of this year, we have made new advances in the delegation of power to the enterprises, reform of the price system, the trial revenue-sharing system, and the promotion of plant director's responsibility system. The outlook for industrial and agricultural production is bright. A big increase in industrial production and revenue was posted from January to April. A bumper mid-season harvest looks promising. To continue good provincial work and build Anhui into a fairly economically developed province, rapid development in science and technology is quite necessary. We want speed as well as results out of science and technology. Science and technology development should be a guide for economic development.

Speaking about ways to develop science and technology and building of four modernizations in Anhui, Comrade Huang Huang said: First, we must seriously study and implement "The Decision of the CPC Central Committee on the Structural Reform of Science and Technology." The decision fully shows that the party Central Committee upholds the spirit of perseverance in reform and in further opening to the outside world and the enlivening of economy. The decision also lays down various policies in developing China's science and technology; it is another important programmatic document following "The Decision of the CPC Central Committee on the Reform of the Economic Structure." Second, we should extensively promote

popular science and technology innovation activities, do a good job in absorbing technology and equipment, let a rational flow of personnel, and seriously implement the party's policy on intellectuals.

Third, we should greatly promote technical markets and commercialize S&T results. This is our party's important policy on science and technology work in the new era. Leaders at various levels and scientific research departments should consider this task as a breakthrough point in S&T structural reform.

Fourth, leaders at various levels should exert equal efforts in studying S&T work and economic work, step up the building of S&T organizations and contingents of S&T cadres. We should also unite and cooperate well on S&T work. Comrade Huang Huang pointed out that regarding S&T structural reform we should also "be steadfast, be careful in fighting the first battle, and have the will to win."

CSO: 4008/2004

NATIONAL DEVELOPMENTS

YUNNAN VICE GOVERNOR ON SCIENCE-TECHNOLOGY REFORM

HK310227 Kunming Yunnan Provincial Service in Mandarin 1100 GMT 29 May 85

[Text] Our provincial conference on scientific and technological work continued its work today. This morning, entrusted by the provincial government, Vice Governor He Zhiqiang attended the conference and delivered an important speech on the key points and tasks of reform of the science and technology system.

In his speech he analyzed the situation on the science and technology front in our province and fully affirmed the achievements made by the science and technology front in our province. At the same time, he pointed out some problems existing in our scientific and technological work. He emphasized: It is necessary to reform the current system of science and technology. Without reform, there will be no way out.

In his speech, Vice Governor He Zhiqiang laid stress on the key points of reform of the system of science and technology in our province. He pointed out that the fundamental aim of reform of the science and technology system is to quickly and extensively apply scientific and technological achievements to production, to give full play to the role of science and technology personnel, to greatly emancipate the scientific and technological productive forces, and to promote economic and social development.

He held that in conjunction with the actual situation of our province, we must now emphatically grasp well the following five aspects of work: 1) Reforming the financial system for the appropriation of funds; 2) expanding the technological market; 3) strengthening of the enterprises' ability to absorb technology and to develop; 4) reforming the system of agricultural science and technology; and 5) reforming the system of the management of science and technology personnel.

Regarding these five aspects of work, He Zhiqiang emphatically pointed out: Reform of the system of appropriating funds for science and technology is a key to reform of the system of science and technology. The expansion of the technological market is an important link in reform of the science and technology system.

In his speech, in light of the present economic, scientific, and technological state of our province, Vice Governor He Zhiqiang proposed eight tasks to the science and technology workers in our province on the questions of how to link science and technology with the economy and how to climb up the mountain to pick peaches.

NATIONAL DEVELOPMENTS

WANG FANG, XUE JU TALK WITH CAS GROUP

OWL61407 Hangzhou ZHEJIANG RIBAO in Chinese 8 Jun 85 p 1

[Text] At the invitation of the Zhejiang Provincial CPC Committee and the provincial government, the Chinese Academy of Sciences [CAS] study group conducted an on-the-spot study in Hangzhou and Ningbo from 26 May to 5 June and consulted with units concerned in Hangzhou and Ningbo on over 100 projects intended for cooperation. These projects tend to produce economic and social benefits fairly faster.

In recent years, some CAS institutes have entered into scientific and technical cooperation with factories and mines in our province. Through talks between our province and the academy, the ties between the two sides will be closer and in varied forms. Both sides have pledged to prepare good conditions for carrying out the discussed projects. The CAS chiefly will provide advanced technology and make intellectual investment and will endeavor to apply some newly achieved technology to some projects entrusted to it. It will also supply Zhejiang with a proper number of college students and postgraduates after their training. Our province warmly welcomes CAS' scientific and technical cadres to work in our province and will fully respect their choice of working units and the professional specialization they opt for. We will provide them with necessary working and living conditions.

During its stay in Zhejiang, the CAS study group was accorded warm hospitality. Comrades Wang Fang and Xue Ju met all members of the group and exchanged views on issues of scientific and technical cooperation with Yan Dongsheng, secretary of the CAS party leading group and vice president, Hu Yongchang, member of the party leading group and deputy secretary general, and Gu Dehuan, former adviser to the CAS.

CSO: 4008/2004

NATIONAL DEVELOPMENTS

SCIENTIFIC, TECHNOLOGICAL ASSOCIATION MEETING OPENS

SK130649 Harbin Heilongjiang Provincial Service in Mandarin 1000 GMT 12 Jun 85

[Excerpts] The third congress of the provincial Scientific and Technological Association opened at the provincial exhibition hall today. Provincial party and government leaders, including Hou Jie, Chen Yunlin, Liu Chengguo, Zhou Wenhua, Wang Fei, Wang Yusheng, Zhu Dianming, Li He, Wang Jinling, Liu Huixian, and Zhao Zhenhua attended to extend congratulations. Hong Jing, vice chairman of the provincial Scientific and Technological Association gave an opening speech. After that, Chen Yunlin, deputy secretary of the provincial CPC Committee, gave a congratulatory speech on behalf of the provincial CPC Committee.

Comrade Chen Yunlin pointed out: With a vast territory and abundant resources, our province has an exceptional advantage in developing the economy. However, in terms of comprehensive economic results, and product quality, it always occupies an inferior position. Its superiority in one field and inferiority in the other show its backwardness in science and technology. Scientific and technological associations at various levels shoulder glorious and yet arduous tasks for revitalizing our province's economy. The provincial CPC Committee hopes that these associations will regard promotion of economic development as their major tasks, and serve as good advisers to policy-making organs at various levels. They should voluntarily help various departments in applying scientific and technological results, organize scientific and technical personnel to tackle technical difficulties, greatly expand technology markets, and study and solve in a timely manner the new problems they face in economic construction.

More than 1,000 scientific and technical workers of our province attended the congress. During the congress, they will hear and discuss a report on the work of the second committee of the provincial Scientific and Technological Association; elect members of the third provincial committee of the association; and offer suggestions on our province's scientific and technical work, economic construction, and the various fields of work of the provincial scientific and technological association.

CSO: 4008/2004

SCHOLARS URGE EMPHASIS ON INTEGRATED SCIENCE

OW160251 Beijing XINHUA in English 0238 GMT 16 Jun 85

[Text] Beijing, 16 Jun (XINHUA)--Leading Chinese scholars recently urged China to put more emphasis on the integration of scientific disciplines, a trend which they predicted will dominate the world by the end of this century and throughout the next, according to the WORLD ECONOMIC HERALD.

Integrated science merges the natural and social sciences into a coordinated whole, said noted Chinese scholars Qian Xuesen, Qian Sanqiang and Qian Weichang.

At the beginning of this century, they reasoned, a great scientific revolution took place. But several decades later, the tempo of scientific development began to slow down. It can be expected that by the end of this century there will be new efforts to bridge the gap between the natural and social sciences.

To realize the four modernizations by the end of this century, China must explore these new disciplines, which include urban studies, marine sciences, energy and space research, biotechnology and science of food values, they said.

Of particular interest are fields vital to the modernization drive, such as management and systems engineering, and science of leadership, the three leading scientists said.

China still sticks to so-called vertical research in a given field, ignoring its horizontal connections with other disciplines and thus failing to solve economic and social problems comprehensively.

CSO: 4010/2004

NATIONAL DEVELOPMENTS

PRC PRODUCES ANTARCTIC EXPEDITION DOCUMENTARY

OWL70822 Beijing XINHUA in English 0638 GMT 17 Jun 85

[Text] Beijing, 17 Jun (XINHUA)--"South Pole, We've Come," a documentary about China's first Antarctic expedition, has been made by the central newsreel and documentary film studio.

The 70-minute-long film will be distributed in Chinese, English, French, German, Japanese, Arabic, Spanish and Portuguese by the China Film Distribution and Exhibition Corporation, according to the studio's editor-in-chief Zhao Hua today.

The film records the expedition from its start when the expedition team left Shanghai on 20 November 1984, and ends with the team's return to Beijing on 13 April this year. It includes the 26,433-knot voyage, the building of China's first Antarctic research station and exploration of the land and seas of Antarctica.

It was shot by Shao Zhentang and Hao Qiangguo. Shao said working conditions were dangerous and they had nearly lost their lives several times.

"Popular Film," a monthly with a readership of five million, has listed the making of the film as one of the 10 top news about the country's film work last year.

The editor-in-chief said several shorter documentaries about Antarctica's scenery and penguin population, as well as Argentina's Ushuaia, the southernmost city of the world, will be finished later this year.

CSO: 4010/2004

NATIONAL DEVELOPMENTS

BRIEFS

PRC-FRG COMBINED COMMITTEE MEETS--Bonn, 31 May (XINHUA)--The third meeting of the Mixed Committee for Cooperation in Development Policies of the Chinese Government and the FRG Government concluded here today, and summary of talks was signed. Li Ke, deputy to the Chinese minister of foreign economic relations and trade, and (Lunger), secretary of state of the FRG Ministry of Economic Cooperation, signed the summary on behalf of their respective governments. The third meeting of the mixed committee began on 28 May. During the meeting, representatives of both sides expressed satisfaction over the cooperation between the governments of the two countries in their development and assistance policies since the second meeting in 1984. Both sides also reached an agreement on cooperation in development policies during 1985, including specific projects of technical and financial cooperation. Both sides unambiguously indicated that they would continue to strengthen economic and technical cooperation between the two countries. [Text] [Beijing XINHUA Domestic Service in Chinese 0925 GMT 1 Jun 85 OW]

SCIENCE, TECHNOLOGY MEETING CONCLUDES--The provincial meeting on science and technology, sponsored by the provincial government, concluded in Kunming this afternoon. The concluding session was attended by He Zhiqiang and Li Zhengyou, vice governors. More than 500 representatives of the province's science and technology fronts attended the 6-day meeting, which conveyed and acted in the spirit of the national work conference on science and technology. The meeting also conveyed the CPC Central Committee resolution on reforming the science and technology structures. It conscientiously summed up the achievements made in the provincial science and technology work, as well as the preliminary experience in reforming the science and technology structures gained over the years. Integrating with the province's actual conditions, the meeting discussed in depth the plans and key points for reforming the province's science and technology structures. It also discussed five specific measures about reforming the science and technology structures, including the interim provisions for reforming the supervision of funds allotted for scientific and technological usage. In the course of the meeting, Vice Governor He Zhiqiang delivered a speech. [passage omitted] [Excerpt] [Kunming Yunnan Provincial Service in Mandarin 1100 GMT 31 May 85 HK]

SHANGHAI SCIENCE SOCIETY--The Shanghai Urban Science Society was inaugurated yesterday. At the inaugural meeting, Wang Daohan, mayor of Shanghai Municipality, was elected honorary chairman of the society. [Summary] [Shanghai JIEFANG RIBAO in Chinese 16 Apr 85 p 3]

SHANGHAI CYCLOTRON REMODELLING--The Chinese Academy of Sciences recently gave a cash award of 50,000 yuan to scientific and technical personnel of the Shanghai Nuclear Institute, who successfully remodelled a backward accelerator into China's most advanced cyclotron, which passed technical apprisement in March 1984. The energy of this cyclotron has been quadrupled, while the remodelling cost was only one-sixth of that for building a new one. [Summary] [Shanghai City Service in Mandarin 0100 GMT 22 Apr 85]

CSO: 4008/2004

PHYSICAL SCIENCES

VARIATIONAL ANALYSIS OF PHASE TRANSITION IN PURE LATTICE GAUGE FIELDS*

Guangzhou ZHONGSHAN DAXUE XUEBAO (ZIRAN KEXUE BAN) [ACTA SCIENTIARUM NATURALIUM UNIVERSITATIS SUNYATSEN] in Chinese No 4, Nov 84 pp 48-54

[Article* by Guo Shuohong [6753 4311 7703], Liu Jinming [0491 6855 2494], and Chen Qizhou [7115 0796 3116] of Physics Department]

[Abstract] A modified mean field theory applying an improved variational action with mixed plaquette-like variables is used to study the phase transition of 4-dimensional pure lattice gauge systems. The theory gave the overall behavior of mean plaquette energies E_p for U(2), U(3), SU(3) and SU(2) groups over a wide range of β , including the phase transition or crossover region, and explained that the phase transitions in SU(2) and SU(3) pure lattice gauge systems are absent. The $E_p \sim \beta$ curves agree with Monte Carlo results and are better than that given by simple mean field theory.

[Text] In recent years mean field theory has been used in the discussion of the phase transition in lattice gauge systems^{1,2}. However, the simple mean field theory is too crude; for example, when the mean field theory is applied to a SU(2) gauge system, it predicted phase transition whereas Monte Carlo calculation only showed a peak in the specific heat. A number of refinements have been proposed for the mean field theory.^{3,4} In this article we follow the method in Ref 4 and use an improved variational action with mixed plaquette-link variables and found no phase transition in the SU(2) system. We also obtained E_p versus β curves for U(1), U(3) and SU(3) gauge systems. The calculated results agree better with the Monte Carlo results than that given by the simple mean field theory.

This paper was received in March 1984.

*This work was funded by Science Foundation of the Chinese Academy of Science and the Higher Academy Research Center of Zhongshan University.

I. Mixed Plaquette-Link Variable as Variational Action

In lattice gauge theories, actions of the pure gauge field is to be

$$S = \frac{\beta}{\text{tr}1} \sum_P \text{Re tr} U_P \quad (1)$$

and the corresponding partition function Z and free energy W are respectively

$$Z = \int DU e^S, \quad DU = \prod_l dU_l \quad (2)$$

$$W = -\ln Z \quad (3)$$

where U_l is an element on link l and $\text{tr}1$ is the dimension of the group representation. $\beta = 1/g^2$, g is a coupling constant. P represents a plaquette element and U_P is the product of U on the four links of plaquette P.

Replacing action S with action S_0 and introducing the corresponding variational partition function Z_0 and variational free energy W_0 ,

$$(4)$$

$$Z_0 = \int DU e^{S_0} \quad (5)$$

the inequality

$$W_0 = -\ln Z_0$$

$$(6)$$

$$\langle e^x \rangle_0 \geq e^{\langle x \rangle_0}$$

then leads to

$$W \leq W_0 + \langle S_0 - S \rangle_0 \quad (7)$$

where $\langle \rangle_0$ is the average value in action S_0 .

As can be seen from the above inequality, the choice of S_0 should be made to minimize the right hand side of inequality in formula (7). The mean field theory takes S_0 to be

$$S_0 = \frac{z}{\text{tr}1} \sum_l \text{Re tr} U_l \quad (8)$$

where z is a variational parameter that minimizes the right hand side of formula (7). For convenience we should call U_l the link variable and U_P the plaquette variable. The mean field action actually converts finding the trace of (1) with respect to U_P to finding the trace of (1) with respect to U_l and ignores the coupling between the links. To improve the mean field theory, we realized that if the first link U_1 in S_0 is changed back to a plaquette variable

$U'_1 = U_1 U_2 U_3 U_4$ containing $l = 1$ then the new variational action S_0 will be

$$S_1 = \frac{z}{\text{tr}1} \text{Re tr} (U'_1 + \sum_{l=1}^4 U_l) \quad (9)$$

and the corresponding variational partition function Z_1 will be

$$Z_1 = \int DU e^{S_1} \quad (10)$$

and

$$Z_1 = Z_0, \quad \langle S_1 \rangle_1 = \langle S_0 \rangle_0 \quad (11)$$

will be satisfied. However, we now have

$$\langle S \rangle_1 \neq \langle S \rangle_0 \quad (12)$$

If $\langle S \rangle_1 > \langle S \rangle_0$, then formula (7) shows that S_1 will lead to a free energy closer to the correct value than S_0 would. Direct calculation shows

$$\langle S \rangle_1 - \langle S \rangle_0 = m_0 + 5m_0^7 - 6m_0^4 \quad (13)$$

where

$$m_0 = \left\langle \frac{1}{\text{tr}1} \text{Re tr} U_1 \right\rangle_0 \quad (14)$$

is the mean field average of U_1 . From (13), $\langle S \rangle_1$ will be greater than $\langle S \rangle_0$ if m_0^3 is less than $1/5$. Similarly, we may convert more links into plaquettes and obtain better approximations.

In computing the average of a physical quantity, there is another possibility for choosing the variational action. Let S_i and S_j be two variational actions satisfying

$$Z_j = Z_i \quad (15)$$

$$\langle S_j \rangle_j = \langle S_i \rangle_i, \quad \langle S \rangle_j = \langle S \rangle_i \quad (16)$$

If the average of a positive definite physical quantity in a system of action S is given by

$$\langle X \rangle = Z^{-1} \int DU e^{S} X \quad (17)$$

we then have the following inequalities for variational actions S_i and S_j

$$\ln(Z \langle X \rangle) \geq \ln Z_j + \langle S - S_j + \ln X \rangle_j \quad (18)$$

$$\ln(Z \langle X \rangle) \geq \ln Z_i + \langle S - S_i + \ln X \rangle_i \quad (19)$$

From (15) and (16), we can see that S_j will lead to a more accurate upper limit of $Z \langle X \rangle$ when $\langle \ln X \rangle_j > \langle \ln X \rangle_i$.

Introducing average E_p for the plaquette

$$E_p = \left\langle \frac{1}{\text{tr}1} \text{Re tr} U_p \right\rangle \quad (20)$$

and average m for link in S_j

$$m = \left\langle \frac{1}{\text{tr}1} \text{Re tr} U_i \right\rangle_j \quad (21)$$

and taking X as the positive definite physical quantity as

$$X = e^{-\frac{\lambda}{\text{tr}1} \text{Re tr} U_p}, \quad 0 < \lambda \ll 1. \quad (22)$$

then, substituting into (18), we have, when n is very small,

$$\ln Z + \lambda E_p \geq \ln Z_j + \langle S - S_j \rangle_j + \lambda m \quad (23)$$

Because of the inequality or (7), the above equation generally cannot determine the upper limit of E_p . However, if S_j is already approaching S so that

$\ln Z \approx \langle S - S_j \rangle_j$, then S_j will give a better upper limit for E_p if

$$\langle \text{Re tr} U_p \rangle_j > \langle \text{Re tr} U_p \rangle_i.$$

Let S_j be the mixed plaquette-link action, then S_j will give the greater

$\left\langle \frac{1}{\text{tr}1} \text{Re} U_p \right\rangle = m$, if S_j contains plaquette U_p . Thus,

$$E_p = m \quad (24)$$

In order to have the greater m for a given β , the ratio of plaquette variables to link variables in S_j should be made as large as possible. We also noticed that, when β is not large, E_p is mainly due to the contribution of field variables in the vicinity of plaquette P . It is therefore possible to have a greater plaquette to link ratio in a local region. In the local region we select a group of links U_i and choose a variational action so that U_i is not coupled to the other links U_e :

$$S_j = S_e(U_e) + S_i(U_i) \quad (25)$$

$$S_e = \frac{\beta}{\text{tr}1} \sum'_p \text{Re tr} U_p \quad (26)$$

$$S_i = \frac{z}{\text{tr}1} \sum'_i \text{Re tr} U_i \quad (27)$$

where \sum'_p is a sum over all plaquettes not containing U_i and z is a variational parameter. Hence, we have

$$Z_j = \int \prod dU_e e^{-\frac{\beta}{\text{tr}1} \sum'_p \text{Re tr} U_p} \int \prod dU_i e^{S_i(U_i)} \equiv Z_e Z_i \quad (28)$$

and, substituting into (7), we have

$$-\ln \frac{Z}{Z_e} \leq -\ln Z_i - \langle S_j - S \rangle_j, \quad (29)$$

The property of S_j is such that $\langle S_j - S \rangle_j$ only depends on U_i ; hence, we may obtain the minimum $\langle S_j - S \rangle_j$ by converting as many links in S_j as possible to plaquettes. Of the local configurations we considered, the configuration that has the greatest plaquette to link ratio is a double layer hypercube.

Figure 1 depicts an element of the hypercube.

In the 4-dimensional hypercube, the three spatial directions are 1, 2 and 3, and the time direction is 4. There are 6 types of faces, faces in the 12, 23 and 31 directions are bases and faces in the 14, 24 and 34 directions are sides. Each hypercube has 12 sides, 6 upper bases, and 6 lower bases. Each double layer hypercube has 12 sides (all taken to be plaquettes) but only 5 faces of the 6 interface faces can be plaquettes. The four links at the boundary of the one remaining face are already parts of the other plaquettes, it will be referred to as a vacancy. The 6 upper bases and the 6 lower bases are all vacancies, including two as shown in Figure 1.

Figure 1

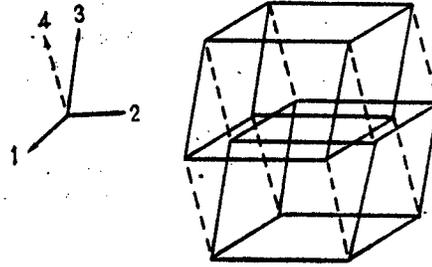

Using the mixed plaquette-link variational action thus formed, we have

$$\langle S \rangle_i = \beta(17m + 11m^2 + 2m^3) \quad (30)$$

$$\langle S_i \rangle_i = z(17m) \quad (31)$$

Choosing the S_j that maximizes $\langle S_i - S \rangle_i$, we have

$$z = \beta \left(1 + \frac{55}{17} m^2 + \frac{18}{17} m^3 \right) \quad (32)$$

where

$$m = Z_i^{-1} \int dU_i e^{\frac{z}{\text{tr} 1} \text{Re tr} U_i} \frac{1}{\text{tr} 1} \text{Re tr} U_i \quad (33)$$

$$Z_i = \int dU_i e^{\frac{z}{\text{tr} 1} \text{Re tr} U_i} \quad (34)$$

m_1 is the single link average, Z_1 is the single link variational partition function, and z is a variational parameter. The E_p versus β curves are obtained by solving (32), (33) and (34) simultaneously.

II. Application

From the above analysis of mixed plaquette-link variational action, the E_p versus β curves may be obtained by merely calculating the single link averages. We now calculate the E_p versus β curves for several common Lie groups.

(1) U(2) group

$$Z_1 = \begin{vmatrix} I_0(x) & I_1(x) \\ I_1(x) & I_0(x) \end{vmatrix}, \quad x = \frac{z}{2}. \quad (35)$$

Direct computation yields

$$m = Z_1^{-1} \frac{dZ_1}{dz} = \frac{x^{-1} I_1^2(x)}{I_0^2(x) - I_1^2(x)} \quad (36)$$

where $I_n(x)$ is the n th order Bessel function. Figure 2 shows a comparison of the calculated result and the Monte Carlo calculation.⁵

Figure 2.

_____ variational calculation
 • Monte Carlo calculation

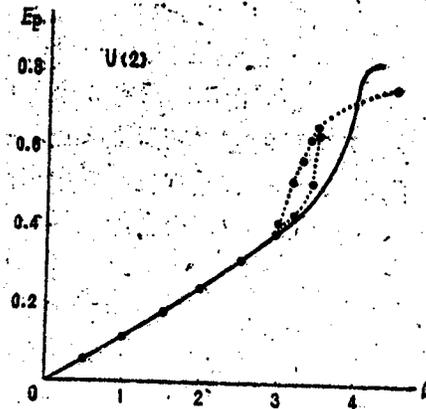

(2) U(3) group

$$Z_1 = \begin{vmatrix} I_0 & I_1 & I_2 \\ I_1 & I_0 & I_1 \\ I_2 & I_1 & I_0 \end{vmatrix} \quad (37)$$

$$m = \frac{I_1(x)}{3I_1(x)} + \frac{1}{3x} \cdot \frac{I_1^2(x) - I_0(x)I_1(x)}{I_0^2(x) - I_1^2(x) - x^{-1}I_0(x)I_1(x)} \quad (38)$$

$$x = \frac{z}{3} \quad (39)$$

where I_n is the abbreviation of the nth order Bessel function $I_n(x)$. Figure 3 shows a comparison of the calculated result and the Monte Carlo calculation.⁵

Figure 3.

———— Variational calculation
 Monte Carlo calculation

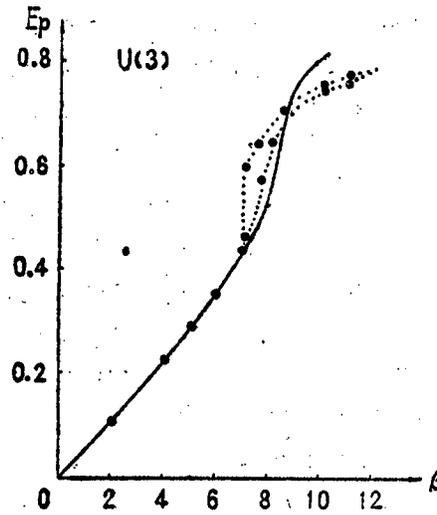

(3) SU(2) group

$$Z_1 = \frac{2I_1(z)}{z} \quad (40)$$

$$m = \frac{I_2(z)}{I_1(z)} \quad (41)$$

Figure 4 shows a comparison of the variational calculation and the Monte Carlo calculation.⁵

Figure 4.

———— variational calculation
 Monte Carlo calculation

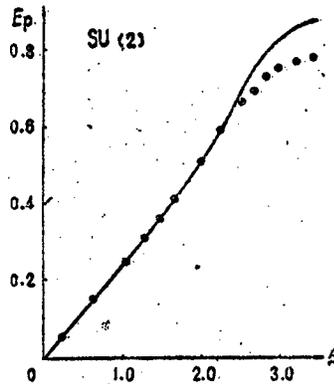

(4) SU(3) group⁷

$$Z_1 = 2 \sum_{k=0}^{\infty} \frac{x^{2k}}{(k+1)!(k+2)!} \sum_{n=0}^k \frac{(2x)^n}{n!} \binom{k+3}{k+n+3}$$

$$\approx \sum_{k=0}^{25} C_k x^k, \quad x = \frac{z}{6}$$

(42)

where Z_1 is a power series of x and converges slowly. For small x ($x < 3$), the error is small after expanding to the 25th term. Equation (42) is therefore an approximation of Z_1 and the coefficients c_n are:

$$\begin{aligned}
 c_0 &= 1 & c_1 &= 0, & c_2 &= 1, & c_3 &= \frac{1}{3}, \\
 c_4 &= \frac{1}{2}, & c_5 &= \frac{1}{4}, & c_6 &= \frac{13}{72}, & c_7 &= \frac{11}{120}, \\
 c_8 &= \frac{139}{2880}, & c_9 &= \frac{19}{864}, & c_{10} &= \frac{23}{2400}, & c_{11} &= \frac{29}{7560}, \\
 c_{12} &= 1.449 \times 10^{-3}, & c_{13} &= 5.130 \times 10^{-4}, \\
 c_{14} &= 1.717 \times 10^{-4}, & c_{15} &= 5.440 \times 10^{-5}, \\
 c_{16} &= 1.637 \times 10^{-5}, & c_{17} &= 4.690 \times 10^{-6}, \\
 c_{18} &= 1.282 \times 10^{-6}, & c_{19} &= 3.352 \times 10^{-7}, \\
 c_{20} &= 1.282 \times 10^{-6}, & c_{21} &= 3.352 \times 10^{-7}, \\
 c_{22} &= 8.396 \times 10^{-8}, & c_{23} &= 2.019 \times 10^{-8}, \\
 c_{24} &= 4.667 \times 10^{-9}, & c_{25} &= 1.039 \times 10^{-9}, \\
 c_{26} &= 2.229 \times 10^{-10}, & c_{27} &= 4.000 \times 10^{-11}.
 \end{aligned}$$

From (42), we have

$$m = \frac{1}{Z_1} \frac{\partial Z_1}{\partial x} = \frac{1}{6} \frac{\partial}{\partial x} \ln Z_1 \quad (43)$$

A comparison of the E_p versus β curve and the Monte Carlo calculation is given in Figure 5.

Figure 5.

- _____ Variational calculation
- Monte Carlo calculation

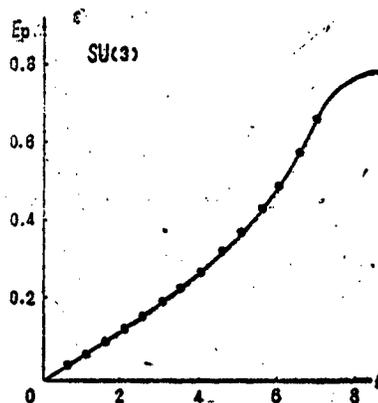

III. Discussion

As can be seen in Figures 2-5, the variationally computed E_p versus β curves are in good agreement with the Monte Carlo method results. We have studied Z_2 , Z_3 , Z_4 , Z_6 , $U(1)$, $U(3)$, $SU(2)$, and $SU(3)$ groups and found that only $SU(2)$ and $SU(3)$ groups have smooth behavior in the cross-over region and that other groups show pronounced phase transition. For example, Z_2 and Z_3 groups have abrupt changes in the cross-over region, such as the $U(2)$ and $U(3)$ pure lattice gauge groups in this work. Our results have therefore partly explained the reason that $SU(2)$, $SU(3)$ groups do not have phase transitions.

References

1. J. Greensite and B. Lautrup, Phys. Lett., 104B (1981), 41.
2. P. Cvitanovic, J. Greensite, and B. Lautrup, Phys. Lett., 105B (1981), 197.
3. Chung-I Tan and Xi-te Zheng, preprint Brown-HET-502 (1983).
4. Guo Shouhong, et al, National Conference on Pure Lattice Gauge Theory, Guangzhou, 1983, p 28.
5. M. Creutz and K. J. Moriarty, Phys. Rev. D25 (1982), 610.
6. M. Creutz, Phys. Rev., D21 (1980), 2308.
7. C. B. Lang, et al, Phys. Lett., 100B (1981), 29.
8. R. C. Edgar, et al, J. Phys., G7 (1981), L85.

9698

CSO: 4008/235

JPRS-CST-85-021
8 July 1985

PHYSICAL SCIENCES

QUANTUM CHEMISTRY OF AROMATIC NITRO EXPLOSIVES

Shanghai HUAXUE XUEBAO [ACTA CHIMICA SINICA] in Chinese, Vol 43, No 1, Jan 85
pp 14-18

[Article by Xiao Heming* [5135 7729 7686], Wang Zunyao** [3769 6690 1031], Yao Jianmin ** [1202 0494 2404] the East China Engineering Institute, Nanjing. "On Sensitivity and Stability. I. Nitro Derivatives of Aminobenzenes"]

[Text] Abstract: The stability of over 20 nitro derivatives of aminobenzene has been studied by HMO and CNDO/2 methods. The results showed that, with increasing bond order of the C-NO₂ bond, the impact sensitivity decreased. The delocalization energy criterion, using isolated double bond as reference, does not reflect the influence which positioning of functional groups has on the stability of the molecule. Its applications are limited to those conjugate systems in which the relative position of functional groups has negligible effects. As a criterion for determining the stability of this series of compound, the C-NO₂ bond order is more appropriate and obvious than the often used delocalization energy. The use of the C-NO₂ bond order criterion is also consistent with the mechanisms of impact initiation and thermal decomposition and also in agreement with Delpuech's $\Delta C/l$ criterion.

The relationship between stability and electronic structure of explosives is a research topic of theoretical and practical interest and was first studied by Delpuech using semi-empirical molecular orbital methods (CNDO-S/CI and INDO). It was proposed that the charge disparity per unit bond length ($\Delta C/l$) of the R-NO₂ bond be used to determine the impact sensitivity of explosives.¹ Based on the mechanisms of thermal decomposition and impact initiation of explosives^{2,3} as well as the Π conjugation characteristic of aromatic compounds, we have

Paper was received on 26 December 1983.

* Correspondent

** Class of 1979

speculated the possible correlation between C-NO₂ bond order and stability. Through calculations, we have pointed out that the heat-resistance and impact initiation resistance of the explosive TATB (1,3,5-triamino-2,4,6-trinitrobenzene) are mainly attributed to its highly symmetrical structure (D_{3h}) and the formation of strong Π_{18}^{24} bond, and, hence, the large C-NO₂ bond order.^{4,5}

In this paper, we calculated the electronic structure of 25 nitro derivatives aminobenzene by the HMO [Huckel molecular orbital] method and of 5 representative explosives--TATB, DATB (diamino-2,4,6-trinitrobenzene), TNA (2,4,6-trinitroaniline), 2,3,4,6-tetranitroaniline and pentanitroaniline by CNDO/2 method. Molecular delocalization energy is based on isolated double bond as the reference standard. Judging by the experimental results, classical electronic effect and $\Delta C/\nu$ criterion, the use of the C-NO₂ bond order criterion for determining the impact sensitivity and thermal stability of this series of compounds is appropriate and the generally accepted delocalization energy criterion has its limitations.

Calculation Methods

Because of the presence of inter- and intra-molecular hydrogen bondings in this series of compound, all but tetranitrobenzene and pentanitrobenzene^{6,7} were treated by planar configuration approximation^{8,9}. Heteroatomic HMO parameters were taken from the literature,¹⁰ they were $k_N=2.0$, $k_O=1.0$, $k_{C-N}=0.8$, $k_{N-O}=0.7$ for nitro compounds; and $k_N=1.5$, $k_{C-N}=1.0$ for aminobenzenes. Non-planar corrections were carried out according to $\beta=\beta_0\cos\theta$ (θ is the torsional angle between the nitro group and the benzene ring). Delocalization energy ΔE is the difference in total energy of Π electrons between the localized reference structure and the delocalized system.

In the full valence electron calculations of the five explosive molecules by the SCF-CNDO/2 method, the relative coordinates of each atom were entered according to Pople's standard configuration¹¹ in order to cancel the system error. The bond angles and dihedral angles in tetranitroaniline and pentanitroaniline were based on the degree their nitro groups are out of plane from the benzene ring.^{6,7} The source program was taken from references [12] and [13]. Calculations were performed on a Siemens 7760 computer.

Calculation Results

The Wiberg bond order¹⁴ (W_{C-N}) and Mulliken bond order¹⁵ (M_{C-N}) of C-NO₂ bond of five explosive molecules were calculated by the CNDO/2 method and are listed in Table 1. When bond orders within a molecule did not agree with one another, the smallest value was used. The $\Delta C/\nu$ values of the C-NO₂ bond, as calculated according to Delpuech's definition,¹ are also listed in Table 1. The h50 percent (cm) in Table 1 is the characteristic height¹⁶ for achieving 50 percent detonation by falling weight impact initiation. Calculated by the HMO method, the bond order (P_{C-N}) of C-NO₂ bond and delocalization energy (ΔE) of 25 compounds are listed in Table 2.

Table 1. CNDO Electronic Structure Parameters and Impact Sensitivity of Five Representative Explosives

Explosives	CNDO/2 Calculation Results			Impact Sensitivity $h_{50\%}$ (cm)
	Wiberg Bond Order W_{C-N}	Mulliken Bond Order M_{C-N}	$\Delta C/N$	
TATB	1.033	0.7214	0.456	>>820
DATB	1.016	0.7159	0.399	820
2,4,6-Trinitroaniline	1.002	0.7112	0.340	177
2,3,4,6-Tetranitroaniline	0.9951	0.7098	0.252	41
Pentanitroaniline	0.9939	0.7096	0.250	15

Table 2. HMO Calculation Results of Nitroaminobenzene Derivatives.

Aminobenzenes	π Bond Order P_{C-N}	Delocalization Energy $\Delta E(B)$	Aminobenzenes	π Bond Order P_{C-N}	Delocalization Energy $\Delta E(B)$
TATB(1)	0.486	0.445	1,4-Diamino-2,3-dinitrobenzene(16)	0.473	-0.371
DATB(2)	0.450	0.802	1,4-Diamino-2,6-dinitrobenzene(17)	0.447	-0.288
TNA(3)	0.419	1.159	1,2-Diamino-3,5-dinitrobenzene(18)	0.429	-0.214
2,3,4,6-Tetranitroaniline(4)	0.181	2.386	1,4-Diamino-2,5-dinitrobenzene(19)	0.420	-0.201
Pentanitroaniline(5)	0.143	3.516	1,3-Diamino-2,5-dinitrobenzene(20)	0.380	-0.194
o-Nitroaniline(6)	0.443	-1.111	2,6-Dinitroaniline(21)	0.442	0.012
m-Nitroaniline(7)	0.401	-1.065	2,4-Dinitroaniline(22)	0.429	0.021
p-Nitroaniline(8)	0.445	-1.117	2,3-Dinitroaniline(23)	0.411	0.046
1,3-Diamino-4-nitrobenzene(9)	0.480	-1.397	2,5-Dinitroaniline(24)	0.384	0.078
1,2-Diamino-4-nitrobenzene(10)	0.451	-1.353	3,5-Dinitroaniline(25)	0.398	0.105
1,3-Diamino-2-nitrobenzene(11)	0.476	-1.381			
1,4-Diamino-2-nitrobenzene(12)	0.450	-1.349			
1,2-Diamino-3-nitrobenzene(13)	0.443	-1.331			
1,3-Diamino-2,4-dinitrobenzene(14)	0.474	-0.310			
1,3-Diamino-4,6-dinitrobenzene(15)	0.454	-0.291			

Discussion

The C-NO₂ Bond Order Criterion: From Tables 1 and 2, it is apparent that the increasing order of the impact sensitivity (i.e. the decreasing order of h50 percent) of five nitroaminobenzene explosives is in agreement with the decreasing order of M_{C-N} and W_{C-N} by CNDO calculations and the P_{C-N} by HMO calculations. It demonstrates that the smaller the C-NO₂ bond order of the explosive, the easier it is to detonate on impact. Since both M_{A-B} and W_{A-B} bond orders reflect the probability of valence electrons appearing between atoms A and B and bond order P_{A-B} is the measurement of electron density, the greater

the C-NO₂ bond order, the stronger the bond. Those explosives with high C-NO₂ bond order are more stable and more inert to impact initiation. This is consistent with the observations that the C-NO₂ bond breaks first during thermal decomposition,² that the C-NO₂ bond has the smallest dissociation energy in aromatic nitro explosives,¹⁷ and with the theoretical model of shockwave initiation.³ It is also consistent with the $\Delta C/1$ criterion¹ for C-NO₂ bond. The bond order criterion emphasizes homolytic cleavage of the valence bond whereas the ΔC value mainly deals with heterolytic cleavage and ionization of the bond. According to Mulliken's overlap populations analysis,¹⁵ the C-N bond order is linked to the charge distribution on carbon and nitrogen atoms. Therefore, the two criteria are complementary.

Delocalization Energy Criterion: Based on different reference standards, delocalization energy can have different definitions.¹⁸ Xi Yanwen [1598 3601 2429] calculated delocalization energy ΔE using isolated double bond as reference standard, to "qualitatively assess the impact sensitivity of explosives."¹⁹ The ΔE values of the first five representative explosives as listed in Table 2 show that the order of their relative impact sensitivity agrees with that based on the bond order criterion, i.e. the larger the ΔE , the smaller the impact sensitivity. TATB has larger $\Delta E(0.445\beta)$ and is the most stable of the five. However, the other 20 compounds in Table 2 all have larger ΔE than TATB's, yet are less stable. This demonstrates the limited applicability of the ΔE criterion.

The analysis of the above-mentioned definition of delocalization energy and its calculation clearly suggests that the type and number of substituent groups on a molecule have great effect on the ΔE value. The more nitro groups, the smaller the ΔE calculated whereas the more amine groups, the larger. Also nitro groups have greater effect than amine groups. Based on the aforementioned heteroatom parameters, a nitro group increases the energy of localized structure by 8.721β while an amine group only by 3β . However, the calculations clearly show that the relative position of substituents has minimal effect on the Π electron total energy of a conjugated molecule and, hence, has little effect on ΔE . Therefore, the ΔE criterion can only reflect the influence on a molecule's stability by the number and type of substituents, and reflects the experimental observation that a nitro group is "activating" and an amine group is "deactivating." But it cannot explain the important effects which the relative position of substituents has on the reaction rate of thermal decomposition, on the mechanism of initiation, as well as on the stability of an explosive molecule.

The Comparison of the ΔE and P_{C-N} Criteria: By the ratio of the number of amine groups (n_{NH_2}) to the number of nitro groups (n_{NO_2}) within a molecule, the last 20 compounds in Table 2 can be classified into 4 categories, i.e. 1:1, 2:1, 2:2 and 1:2. The ΔE is directly proportional to this ratio. When the ratios are the same, the more nitro groups in a molecule, the smaller the ΔE . However, the C-NO₂ bond orders P_{C-N} of these four categories of compound show a complicated irregular pattern. Because of the lack of experimental data on thermal stability for quantitative comparison, the classical equation correlating substituent electronic effect and reaction rate was used for qualitative analysis:

$$\log \frac{k}{k_0} = G + P$$

where k_0 and k are the reaction rates of thermal decomposition before and after substitution. G represents the substituent's tautomeric effect and P represents the substituent's inductive effect. For nitro groups, $P_{NO_2} > 0$, $G_{NO_2} > 0$. Amine groups have both electron-withdrawing inductive effect ($P_{NH_2} > 0$), and electron-donating tautomeric effect ($G_{NH_2} < 0$). A molecule is stabilized when amine groups are ortho (particularly para) to nitro groups and nitro groups are meta to each other. Otherwise, the molecule is less stable.

For compounds 6, 7 and 8 in Table 2, the stability order is p-nitroaniline > o-nitroaniline > m-nitroaniline by both criteria. Also for compound 9, $n_{NH_2}:n_{NO_2}=2:1$ and the relative position of substituents favors stabilization. This agrees with both the larger ΔE value ($= -1.397\beta$) and P_{C-N} value ($=0.480$). However, for compounds 24 and 25, 24 should be more stable ($0.073\beta > 0.105\beta$) by the ΔE criterion whereas 25 should be more stable ($0.398 > 0.384$) by the P_{C-N} criterion. According to equation (1) and substituents arrangement, the P_{C-N} criterion is more useful.

TATB is a typical example. Its $n_{NH_2}:n_{NO_2}=3:3$, and its ΔE value (0.445β) is relatively small, but the substituents arrangement is such that it extremely favors stabilization and, hence, the largest P_{C-N} ($=0.488$). Its especially high stability exemplifies the effectiveness of P_{C-N} criterion.

Unlike delocalization energy, whose calculations tend to be arbitrary, bond order can be obtained directly from molecular orbital calculations. In addition, the C-NO₂ bond order criterion is consistent with the reaction mechanism and is more effective and direct. Therefore, it has a certain importance to studying the stability of aromatic explosives.

The authors want to thank Liu Jingjiang [0491 7231 3984], Sun Mingzhen [1327 0682 2182], and Zhang Xihe [1728 3556 0735] for reading the manuscripts and for their suggestions, Tang Defu [3282 1795 4569] and Qian Huanyan [6929 3562 1693] for discussions and for their help in calculations.

References

1. Delpuech, A., Cherville, J., PROPELLANTS AND EXPLOS., 1978, 3, p 169; 1979, Vol 4, pp 61, 121.
2. "Explosive Theory," National Defense Industry Publishing House, Beijing 1981, p 46.
3. Walker, F. E., PROPELLANTS, EXPLOS. PYROTECHNICS, 1982, Vol 7, p 2.
4. Xiao Heming, Qian Huanyan, Lee Chongde, HUANDONG GONGCHENG XUEYUAN XUEBAO [JOURNAL OF EAST CHINA ENGINEERING INSTITUTE] 1982, p 3.
5. Xiao Heming, Qian Huanyan, Lee Chongde, HUO ZHAYAO [FLAME-EXPLOSIVES] 1983, p 3.
6. Dickison, C., Stewart, J. M., Holden, J. R., ACTA CRYST., 1966, Vol 21, p 663.

7. Kamlet, M. J., J. CHEM. SOC., 1968, p 10.
8. Cady, H. H., Larson, A. C., ACTA CRYST., 1965, Vol 18, p 485.
9. Holden, J. R., ACTA CRYST., 1967, Vol 22, p 545.
10. Streitwieser, A., "Molecular Orbital Theory for Organic Chemists," John Wiley, New York, 1961, pp 123, 135.
11. Pople, J. A., Beveridge, D. L., "Approximate Molecular Orbital Theory," McGraw-Hill, New York, 1970, p 115.
12. Wang Zhizhong, Lee Xiandong, compilers, "Semi-empirical Molecular Orbital Theory," McGraw-Hill, New York, 1970, p 115.
13. Qu Shaoqing, Bai Naibin, personal correspondence.
14. Wiberg, K. B., TETRAHEDRON, 1968, Vol 24, p 1083.
15. Mulliken, R. S., J. CHEM. PHYS., 1955, Vol 23, p 1833.
16. Kamlet, M. J., Adolph, H. G., PROPELLANTS AND EXPLOS., 1979, Vol 4, p 30.
17. Xiao Heming, Wang Zunyang, BINGONG XUEBAO [ACTA ARMAMENTARII], in press.
18. Tang Jiaoqing, Jiang Yuansheng, Yan Guosheng, Dai Shusai, "Molecular Orbital Graphic Theory," Science Press, Beijing, 1980, p 137.
19. Xi Yanwen, HUAGONG TONGXUN [CHEMICAL ENGINEERING NEWSLETTER] 1982, p 1.

12 922
GSO: 4008/1007

APPLIED SCIENCES

ADRH/XLAT, 8080/Z80 BINARY CODE PROGRAM

Chongqing WEIXING JISUANJI [MICROCOMPUTERS] in Chinese No 2, 24 Mar 84
pp 62-70

[Article by Tao Jianyi [7118 1696 3015], Department of Computer Science,
Nanjing University: "8080/Z80 Binary Code Program Translation and Processing"]

[Excerpts] This article introduces in detail the design goals, primary functions, implementation principles, methods of use and some application examples of the ADRH/XLAT translation processing program of the 8080/Z80 binary code program.

I. Design Goals

The first experimental goal was to punch into paper tape the Z80 disassembly detail and translate it into 8080 assembly language routine which can be processed by the DJS-052 basic assembly in order to transplant the existing Z80 instruction microcomputer software to the domestically-manufactured 8080 CPU microcomputer systems more easily.

In addition, in current successful microcomputer systems, large-scale and high-quality software is still written in assembly language, but ordinary entry software does not have an assembly language source program. It is troublesome and difficult to revise binary code programs directly; however, if the binary code program can be changed into an assembly language program through a simple and effective technique, analysis, transplant revision, and cutting out and expanding functions can be carried out easily.

Thus on the foundation of the success in the first experiment, the second goal was to carry out processing of binary code programs and store the assembly language programs produced as disk files so they could be used. I carried out the first goal on an M-8 microcomputer system supported by CP/M 1.4, and in the process of constant use and improvement, the translation processing program XLAT has gained many important functions so that it has become better daily.

Then, to facilitate and promote the application of XLAT, I designed an auxiliary program ADRH to separate the instruction area and data area of the processed program, and obtained satisfying results.

This utility program uses only the following 11 system calls:

- 1* console input
- 2* console output
- 9* character string output
- 0A* Hollerith string input
- 0F* open file
- 10* close file
- 11* search file directory
- 14* read one record sequentially
- 15* write one record sequentially
- 16* set up file
- 1A* set up DMA initial address

Thus it can operate with the support of any edition of CP/M, MP/M and CDOS.

II. Automatic Segmented Program ADRH

2.1 Primary functions of ADRH

As an auxiliary utility program, ADRH is mainly used for carrying out address segmenting of the binary code program being processed and specifying the instruction area and the data area. For executable "COM" instruction files, ADRH can automatically trace, process and generate an address segment table specifying the instruction area and data area for use by the XLAT translation program. For non "COM" files which are structured in memory by absolute address, the operator need only point out the initial address of the segment being processing for the above functions to be carried out automatically.

ADRH also provides the operator with a complete set of instructions. After the program being processed has been analyzed, this set of instructions can be used for artificial adjustment of the address segment table or instruct ADRH to enter dynamically and carry out trace processing.

2.2 Principles of ADRH Implementation

The kernel of ADRH address segment processing is processing the entry address table and address segment table (as in Figure 1). In processing, sequencing algorithm and queuing technology are used in many places so as to improve the processing efficiency.

2.3 Methods of Using ADRH

III. XLAT Translation Processing Program

3.1 Primary functions of XLAT

XLAT is a multifunction utility program. XLAT's most important function is to process a binary coded program in memory or on disk according to the existing address segment table of a temporary address segment table entered

by the operator, and produce an assembly language program file which is stored on disk. XLST processing properties can be 8080 instruction disassembly or cross disassembly of 8080 instructions to Z80 instructions, it can also be Z80 instruction disassembly or translation of Z80 instructions to 8080 instructions, in addition an 8080 instruction assembly program which preserves the Z80 code can also be produced.

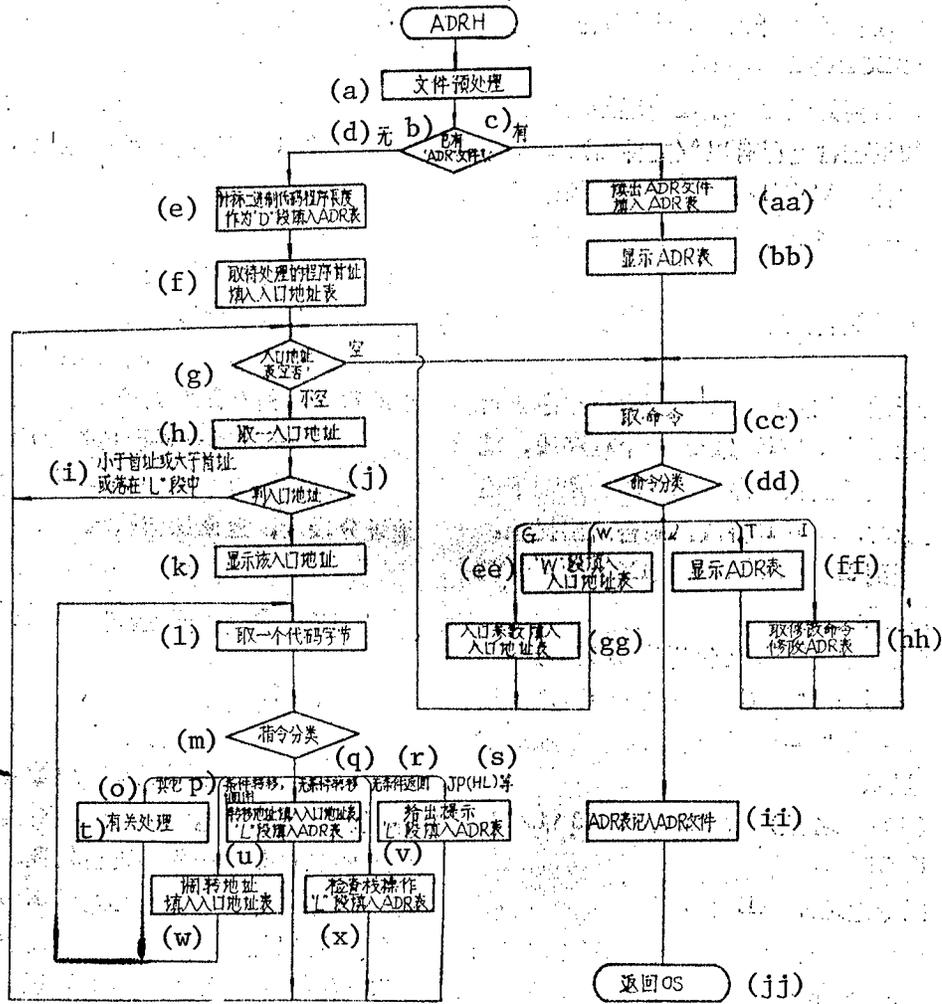

Figure 1 ADRH Outline

- Key:
- a. file preprocessing
 - b. already an ADR file?
 - c. yes
 - d. no
 - e. mark binary coded program length as "d" segment fill in ADR table
 - f. fetch initial address of program to be processed and place in entry address table
 - g. entry address table empty?
 - h. fetch one entry address
 - i. less than initial address or greater than initial address or falls in "L" segment
 - j. determine entry address
 - k. display this entry address
 - l. fetch one coded byte
 - m. instruction class
 - n. instruction class
 - o. other (o) P
 - p. transfer instruction (q) transfer address fill in entry address table "L" segment fill in ADR table
 - q. transfer instruction (q) transfer address fill in entry address table "L" segment fill in ADR table
 - r. no transfer (r) JP(HL) etc
 - s. output prompt "L" segment fill in ADR table
 - t. related processing
 - u. refresh address fill in entry address table
 - v. check stack operation fill in ADR table
 - w. refresh address fill in entry address table
 - x. check stack operation fill in ADR table
 - aa. read ADR file fill in ADR table
 - bb. display ADR table
 - cc. get command
 - dd. command classification
 - ee. W segment fill in entry address table
 - ff. display ADR table
 - gg. entry table number fill in entry address table
 - hh. get modification command modify ADR table
 - ii. ADRH fill in ADR file
 - jj. return OS

(Cont)

Key: o. other
p. conditional shift [unreadable]
q. unconditional shift
r. unconditional return
s. JP (HL) etc.
t. relevant processing
u. shift address fill in entry address table, "L" segment fill in ADR table
v. provide prompt, "L" segment fill in ADR table
w. tiaozhuan [6148 6567] address fill in entry address table
x. check stack operation, "L" segment fill in ADR table
aa. read out ADR file, fill in ADR table
bb. display ADR table
cc. fetch command
dd. command class
ee. "W" segment fill in entry address table
ff. display ADR table
gg. entry parameter, fill entry address table
hh. fetch revised command revise ADR table
ii. record ADR table in ADR file
jj. return to OS

XLAT can process the three pseudo-instructions DB, DW, and EQU. All internal addresses are automatically defined and used according to assembly language regulations, external addresses can also be automatically defined supplementarily using the EQU statement. The operator can carry out supplementary definition of illegal addresses as necessary by indicating them from the console. The resolving program generated by XLAT conforms completely to the demands of assembly language programs and assembly can be carried out directly without additional revision.

At operator command, XLZT can print out a table of multiple address labels. In the address label table, each address label in the program being processed occupies one page, and is sorted by increasing sequence of the defined addresses. The organizational form of each page is: a space is left after a defined address so as to facilitate comment on the function of the corresponding program segment or the definition of the data element, then is given all addresses that use this address label. The address label table provides an unusually useful index for personnel analyzing software and also provides a standard format assembly language program detail which can greatly increase the efficiency of analyzing microcomputer software.

If the program being processed has functions which can be reregistered, on demand XLAT can automatically produce a revised vector file of reregistered addresses which can greatly reduce the complicated work of the program designers.

3.2 Principles of XLAT implementation

Since XLAT is a multifunction utility program, there are many factors to be considered in actual implementation. Here we will describe the primary flow and some key problems of processing.

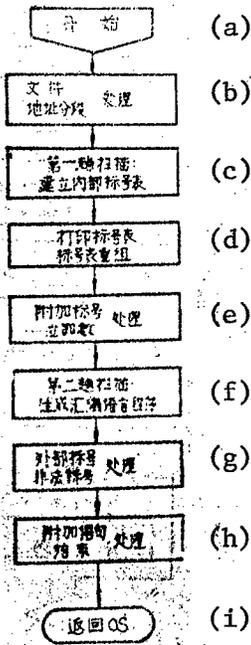

- Key:
- a. start
 - b. file address segment processing
 - c. first scan set up internal label table
 - d. print label table label table reorganization
 - e. append label [unreadable] processing
 - f. second scan: generate assembly language program
 - g. external labels illegal labels processing
 - h. append statement end
 - i. return to OS processing

Figure 2

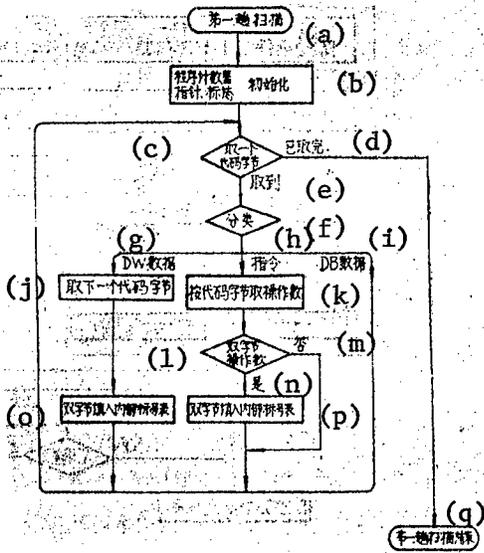

- Key:
- a. first scan
 - b. program counter initialization
 - c. fetch one coded byte
 - d. done
 - e. fetched
 - f. class
 - g. DW data
 - h. instruction
 - i. DB data
 - j. fetch next coded byte
 - k. fetch operations number according to coded by
 - l. double byte operation number?
 - m. no
 - n. yes
 - o. double type fill in internal label table
 - p. double byte fill in internal label table
 - q. first scan completed

Figure 3. First scan in XLAT

1. Primary Flow

2. Processing of Address Table

All addresses can be divided into three classes according to the address label definition: internal addresses are address labels which fall within the program area and can be labelled by XLAT's automatic define; external addresses are address labels which fall outside the program area; illegal addresses are address labels which fall within the program area but cannot be automatically defined by XLAT. It is very clear that external addresses are to shorten program length. When the program was designed, the data area define statement was used to define addresses outside the program area, but illegal addresses are addresses which point to second, third, and fourth byte of instructions or the second byte in a DW data item. XLAT adopts different strategies for processing these three different address labels.

3. Processing of Disassembly

Generally speaking, disassembly and cross-disassembly of 8080/Z80 instructions is one-for-one processing, it is very regular, and can be implemented with a simple table search method.

4. Processing of Translation

8080 instructions are a true subset of Z80 instructions, but the functions of non-8080 instructions in the Z80 instruction set are more powerful than the functions of the 8080 instructions, therefore, processing the translation of non-8080 instructions to 8080 instructions is rather troublesome and many factors need to be considered, and even if it is the same instruction it is still possible that it will be translated into a different program segment because the number of operations is different, a special subprogram is used in XLAT to carry out separate class processing of non-8080 instructions.

3.3 Methods of Using XLAT

IV. Several Examples of Application

Since ADRH/XLAT has gone into use, some very satisfying results have been obtained. For example, when checking program correctness, ADRH/XLAT has been used successfully to translate a CDOS emulator program EX which contained Z80 instructions that had to be reregistered into an 8080 instruction assembly language program. After assembly it operated normally and can be used on an 8080 CPU microcomputer system. If the functions in a new edition of CDOS are improved, a new CDOS emulator program can be obtained.

When processing BDS C language translation and chain program, with just a little manual intervention, processing efficiency is very high.

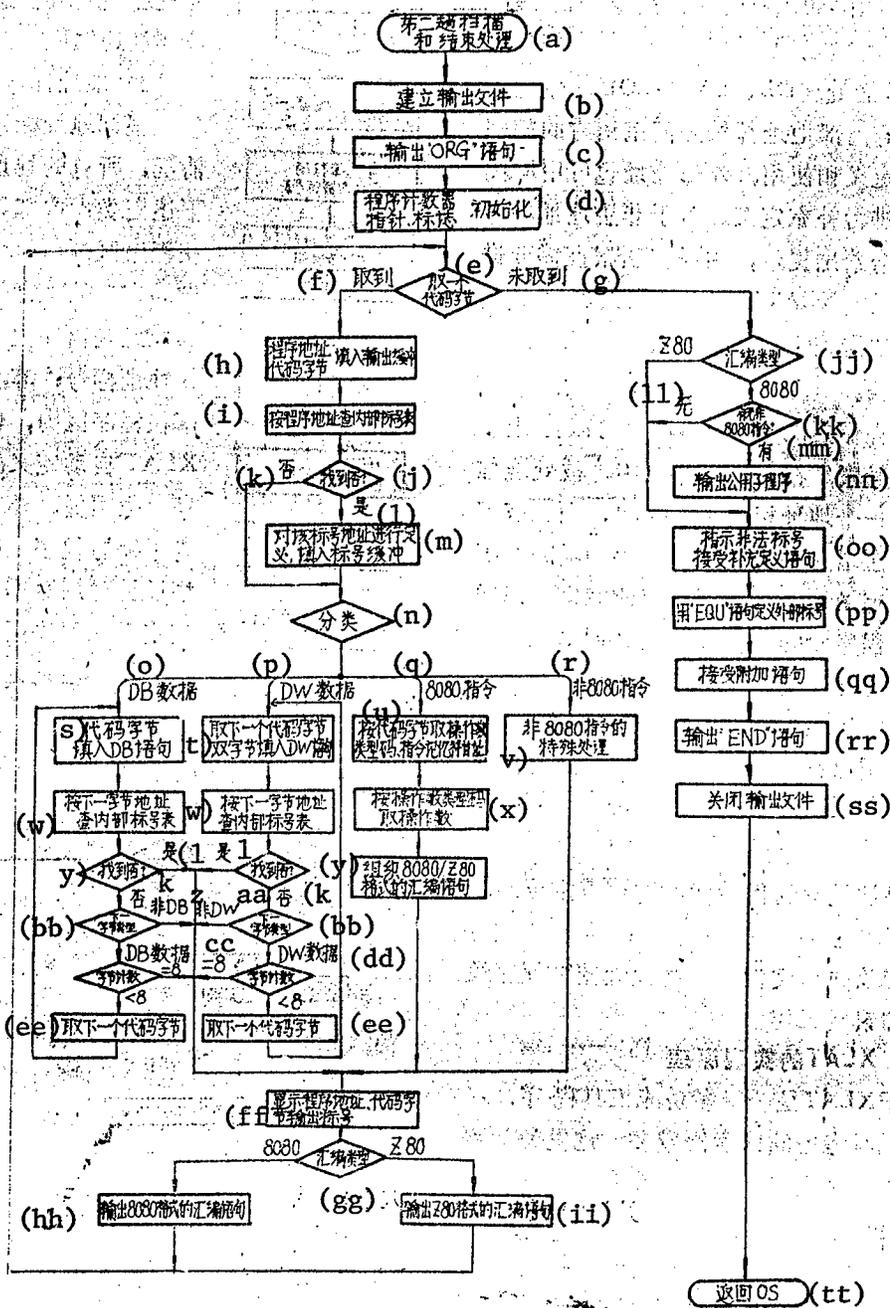

Figure 4. Second scan in XLAT

- | | |
|--|---|
| Key: a. second scan and conclude processing | f. done |
| b. set up output file | g. not done |
| c. output ORG statement | h. program address coded byte fill in output buffer |
| d. initialize program counter, pointer, marker | i. search internal label table according to program address |
| e. fetch first coded byte | j. found? |

(Cont)

Key: k. no
l. yes
m. define this label address;
fill in label buffer
n. class
o. DB data
p. DW data
q. 8080 instruction
r. non-8080 instruction
s. coded byte fill in DB statement
t. fetch next coded byte, double
byte fill in DW statement
u. fetch operating number according
to coded byte, class code,
instruction record corresponding
initial address
v. special processing of non-8080
instructions
w. search internal label table
according to next byte address
x. fetch operating number according
to operating number class code
y. found it?
z. non-BD
aa. non-DW
bb. next byte class
cc. DB data = 8
dd. DW data
ee. fetch next coded byte
ff. display program address, coded
byte output label
gg. assembly class
hh. output 8080 format assembly
statement
ii. output Z80 format assembly
statement
jj. assembly class
kk. [unreadable] 8080 instruction?
ll. no
mm. yes
nn. output common subprogram
oo. indicate illegal label according
to supplementary define
statement
pp. use EQU statement to define
external labels
qq. accept append statement
rr. output END statement
ss. close output file
tt. return to OS

ADRH/XLAT have been used to process many programs including applications software in the CP/M 2.2 operating system, CBASIC compiler and operating programs, and data acquisitions systems and has functioned very well. It has even been used to process XLAT itself and refined the program.

Although this work has obtained preliminary success, it is still only beginning and there is still much work to be done. On the one hand, application of ADRH/XLAT needs to be promoted and on the other, if possible, a new edition of ADRH/XLAT may be designed so that ADRH to automate program outline functions, and so that XLAT will be able to process programs in the M6800 series and other instruction series. This work was carried out under the guidance of "Professor" Zhang Fuyan [1728 1788 3508].

8226

CSO: 4008/1008

APPLIED SCIENCES

PULSED RADIATION DETECTION TECHNOLOGY DISCUSSED

Beijing HEDIANZIXUE YU TANCE JISHU [NUCLEAR ELECTRONICS AND DETECTION TECHNOLOGY] in Chinese Vol 4, No 6, Nov 84 pp 321-328

[Article by Lu Min [0712 2404]]

[Text] The purpose of measuring pulsed radiation is often to understand the pulsed radiation source and its development process, in other words, to analyze the radiation source. In some cases, measuring pulsed radiation is to understand the characteristics of the radiation beam so they can be properly exploited. In the literature, this technology is sometimes referred to as measurement of the ionizing radiation field.

Since the 1940's, significant progress has been made in nuclear physics and many types of pulsed radiation sources such as atomic and hydrogen bombs, pulsed reactors, high-current pulsed accelerators, pulsed X-ray machines, laser or particle beam inertially confined fusion devices, and controllable thermal nuclear research facilities have been developed. These devices are designed for different purposes, and their modes of operation differ significantly, but they all emit strong pulsed radiation. In order to understand the performance and operating procedure of these equipment, it is necessary to measure and analyze the pulsed radiation parameters which include the time of appearance, the time-varying processes, energy spectrum, peak intensity, etc.

As the requirement on pulsed radiation analysis increases and measurement technology improves, the measurement of pulsed radiation has developed into a unique technology. It involves many new technologies such as radiation detection, transmission of fast signals, and recording of monopulse fast signals. Collectively, they form a separate field of applied science--pulsed radiation measurement technology. It is a special branch of nuclear detection technology.

One of the unique features of pulsed radiation measurement technology is that the measured nuclear radiation appears in the form of pulsed beam; there are a large number of nuclear particles reaching the detector within the resolvable time interval. This is clearly different from conventional nuclear detection techniques. The measurement of radiation beam requires that the effect of a large number of particles is contained

in a single output signal; in other words, the detector must interact with a large number of particles simultaneously, and only one signal which contains all the information is collected.

Another unique feature of pulsed radiation beam measurement is the measurement of monopulse. Pulsed radiation sources operate mostly in the monopulse mode; i.e., the measured quantities do not repeat. This constraint dictates the use of automatic measurement techniques and imposes the requirement of high degree of reliability. The potential damages to human and recording instruments also imposes the requirement of developing fast-signal long-distance transmission technique so measurements can be made remotely.

Like conventional nuclear detection technology, pulsed radiation detection involves fast signals. In fact, many new pulsed radiation sources impose increasingly higher demand on the time response of the measurement system.

I. Detection System

A typical measurement system consists of a detector located at a properly selected distance from the source, safely positioned recording equipment, and transmission channels between the detector and the recording equipment. Fig. 1 shows the schematic diagram of a typical system.

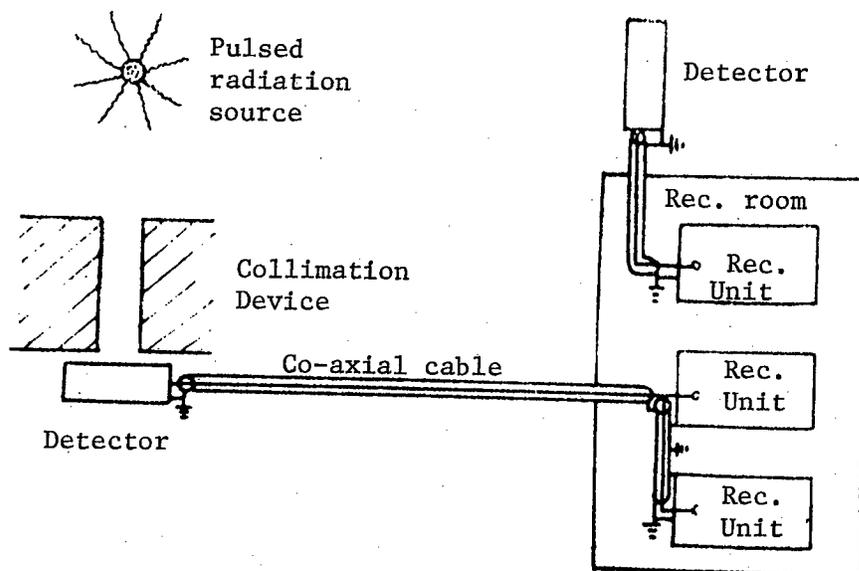

Fig. 1. Schematic Diagram of a Detection System

1. Pulsed Radiation Beam To Be Measured

Different pulsed radiation sources produce different pulsed radiation. To analyze the performance of pulsed radiation sources, it is necessary to measure various parameters of the radiation pulses, generally by measuring its composition. Quite often this is done by measuring neutrons and γ rays because as neutral particles, they are affected by the Coulomb force when propagating through a medium. It can propagate along a straight line over large distances, and therefore provides more flexibility in the placement of detectors. Electrons, protons and X-rays can travel only a short distance in air; to measure these particles requires the use of a complicated vacuum conduit. For this reason they are generally used for performance analysis. But for certain special-purpose measurement, we must measure their waveform parameters. In order to accurately predict the performance of the radiation source from pulse measurements, it is often necessary to collimate the radiation beams before they are measured.

A pulsed radiation beam is primarily characterized by the following parameters: time-varying waveform parameters, and intensity, composition and energy spectrum of the radiation particles. The objective of developing pulsed radiation measurement technology is to accurately determine these parameters.

2. Selection of Measurement System

(1) Selection of Measurement Position. For γ rays, the measurement position can be selected based on the operating range of the detector. To avoid errors caused by differences in the flight paths, the position should be as close to the radiation source as possible, or collimation conduits should be added. For the measurement of neutron beam pulsed waveform it should also be positioned as close to the radiation source as possible to avoid waveform spreading due to energy dispersion. For the measurement of energy spectrum of neutron beams, the detector should be positioned at larger distances so that the technique of flight-time energy spectrum measurement can be used. For the measurement of X-rays and charged particles such as electrons and protons one must consider the possibility of constructing a vacuum conduit when selection the measurement position. The selected position must be consistent with the detector, so that the radiation intensity will fall within the dynamic range of the detector.

(2) Requirements on the Sensitivity and Dynamic Range of the Detection System. The sensitivity and dynamic range of the detector system are primarily determined by the detector. Once the source strength and the measurement position are selected, the radiation intensity at the measurement point can be readily determined. The range of intensity to be measured is determined by the objective of the experiment. Then, the sensitivity and dynamic range of the detection system are selected to meet requirements for measuring the waveform in this particular band.

The dynamic range of a detector is the range between the upper and lower intensity limits where it can operate accurately. The upper intensity

limit is determined by considering the effect of radiation damage to the detector equipment; the lower intensity limit is dictated by the amplitude of the interference signal and the statistical fluctuations of the number of particles interacting with the detector. In general, the dynamic range of the detector should be greater than 10^2 .

(3) Linearity Requirement on the Detection System. In order that the output signal waveform of the detection system can accurately reflect variations in the radiation intensity, the measurement is required to operate in a linear mode; i.e., the output signal must be proportional to the input radiation intensity. This requires that the detector, the transmission cable, the recording oscilloscope, and the camera readout equipment all operate in a linear mode. For example, if it is required to have a measurement accuracy of 5 percent, then the linearity must be controlled to within 5 percent or some other specified number; in other words, within the maximum usable range of each link of the system, deviation from linearity cannot exceed 5 percent or some equivalent number. Therefore, in selecting a detection system, one must pay strict attention to the linearity specification of every link in order to achieve satisfactory results.

In cases where the measurement dynamic range is large and the accuracy requirement is less demanding, non-linear components (such as logarithmic amplifier) can be used; however, the input-output amplitude characteristics must be carefully specified and the data must be processed point by point. In general, errors for a non-linear system are larger than those of a linear measurement system, and a careful error analysis is required.

The range of linear operation depends on the width of the waveform; therefore, the selection of an appropriate pulse width is important in verifying the linearity specification.

(4) Requirement on the Time Response of a Detection System. In order to accurately determine the waveform parameters of a pulsed radiation beam, the response time of the measurement system must be considerably shorter than the time parameters of the measured waveform; i.e., the frequency band of the detection system must be much higher than the maximum frequency of the measured signal. In many experiments, the waveform itself is of the order of nanoseconds, therefore, the time response of the detector, the recording system and the transmission link must be of the order of nanoseconds or faster. Generally, the response time of the detection system should be $1/3$ to $1/5$ of the time parameters to be measured. In the measurement of fast signals, the requirement on system time response is even higher; to meet this requirement, the investment may be significantly increased. Therefore, it is necessary to determine the minimum requirement on system response based on practical needs.

The technical standards of current detection systems sometimes cannot satisfy the time response required by some experiments. Quite often data processing techniques such as the method of inverse folding integration are used to provide proper compensation. Before actual measurements are

made, the time response function of the system, $g(t)$, is accurately determined; it is the system output waveform that corresponds to an extremely fast input signal. By using the function $g(t)$, the measured pulsed radiation waveform is processed numerically to determine the true waveform of the radiation beam. This method can be used to correct the measured parameters to a certain degree.

In some experiments, it is required to measure the entire waveform history, including the waveform after the appearance of the peak value. This requires not only fast time response but also good transition characteristics of the detection system in order to measure the fine structure of the post-peak waveform.

(5) Other Requirements on the Detection System. In the measurement of pulsed radiation, the strong radiation source will interact not only with the detection elements but also with the auxiliary components, thereby creating interference signals. Nuclear explosion and radiation sources involving high voltage discharge will also produce strong electromagnetic pulse, which will induce strong interference signals, or even damage the elements and components in the detection system. If no protective measure is taken the measured signal may be totally masked by the interference signal, which is detrimental for the measurement of a single, non-repeatable radiation source. Therefore, the anti-radiation and anti-electromagnetic interference capability is also an important technical indicator of the detection system^[1].

A pulsed radiation measurement system consists of many links which may be scattered over a wide area; it also operates in a single, non-repeatable mode. Therefore, it must be highly reliable and there must be a procedure for inspection and verification of the overall system.

II. Detection Techniques and Detectors

Most of the detection techniques used for nuclear radiation such as scintillation detectors, Cerenkov detectors, semiconductor detectors can also be used for the measurement of pulsed radiation. But their modes of operation are different. In pulsed radiation measurement, the detector output must be pulsed current which is directly proportional to the input radiation intensity; for this reason it is called the electric current type radiation detector. Radiation beam measurement also uses low-sensitivity detectors such as photo-electric tubes, Compton diodes, and Faraday cylinders, which are rarely used in conventional nuclear radiation detectors. On the other hand, proportional counters and ionization chambers are seldom used in radiation beam measurement because of their slow response time.

During the past few decades, many electric current type detectors have been developed; however, a great deal of research work is still being carried out to develop high-technology detectors to meet the ever increasing measurement requirements^[2].

1. Factors Which Affect the Performance of Electric Current Type Detectors

In this section we shall discuss methods of evaluating detector sensitivity and time response based on the general principle of detectors.

Detector sensitivity is measured in units of $A/(\text{number cm}^{-2} \cdot \text{s}^{-1})$. For the detection of charged particles, $s \approx (AE_d/\omega) \times 1.6 \times 10^{-19}$; for neutral particles $s \approx [A(1 - e^{-\mu d}) E_e/\omega] \times 1.6 \times 10^{-19}$, where A is the detector area perpendicular to the radiation beam, expressed in cm^2 ; E_d is the energy loss of each charged particle within the sensitivity region of the detector expressed in eV; μ is the absorption coefficient, expressed in cm^{-1} ; d is the thickness of the sensitivity region of the detector element, expressed in cm; $A(1 - e^{-\mu d})$ is the probability of interaction between the particles and the detector; E_e is the mean energy of secondary particles produced by each interaction, expressed in eV; ω is the average energy consumed in producing a unit charge, expressed in eV. E_d , E_e and μ are functions of the particle energy which can be obtained directly from a handbook or calculated from quantities given in the handbook. ω can be obtained from Table 1. The above formula did not consider the contribution of secondary particles that have escaped from the sensitivity region or secondary particles produced from the material of the detector structure. Therefore, it is only a theoretical formula which can be used to provide rough estimates or as a reference in designing the measurement system and in selecting detectors.

Table 1. Typical Values of the Average Energy Consumption for Producing a Unit Charge From the Radiation Detector, eV

semiconductor detector	ionization chamber	NaI(Tl) + photoelectric equipment	plastic scintillator + photoelectric equipment	Cerenkov radiator + photoelectric equipment	charge detector
3	30	3×10^2	3×10^3	3×10^5	10^6

The time response of a detector consists of two parts. The first part is the pulse delay and pulse spreading caused by the production process and collection process of electric charge due to radiation interaction; this is exemplified by the scintillator excitation process, the electron transition multiplication process in the photoelectric multiplier, and the transport process of electron cavity in the semiconductor. The second part is the response of the electrical components of the detection system. This includes the contribution of the circuit elements as well as the detection elements. Any detector has its own inductance and capacitance; they sometimes become the major factor of the time response of the detector system. Fig. 2 shows a simplified equivalent circuit of the detector.

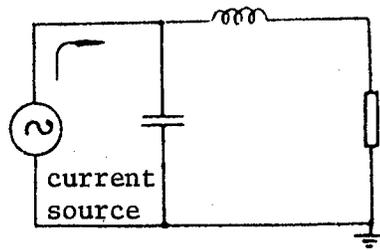

Fig. 2. Simplified Equivalent Circuit of the Detector

The detector under radiation corresponds to a current source. The capacitance C is primarily determined by the geometric structure of the detector in addition to the distributed capacitors. The inductance L is primarily determined by the detector structure and the signal output structure. The load resistance R_L , although selectable, is actually determined by the characteristic impedance of the co-axial cable because of the long-distance transmission. The internal resistance of the detector generally has no significant effect on the response time.

The response function of the equivalent circuit can generally be written as:

$$q(t) = \frac{1}{R_L C - L/R_L} \left(e^{-\frac{t}{R_L C}} - e^{-\frac{t R_L}{L}} \right)$$

The rising leading edge of the response function is determined by L , and the descent portion is determined by C . It is difficult to lower the value of C because it includes the structural parameters of the detector; for many detectors it is the dominant factor of the time response. The commonly used flat-plate electrode detector may have an internal capacitance of more than 20 pf, hence the contribution of $R \cdot C$ alone exceeds 1 nanosecond. Therefore, to improve the detector performance in measuring nanosecond waveforms, it is necessary to build a detector with a co-axial type structure.

The basic microscopic process of radiation detection is the interaction between a radiated particle and the detector; since they are independent events, their cumulated effect should be essentially linear. Therefore, it is reasonable to assume that most electric current type detectors operate in a linear mode over a fairly wide range. But once the number of particles interacting with the detector reaches a certain level, the operation of the detector begins to change, and non-linear effects begin to appear. For example, in the case of a scintillator under high intensity radiation, the degree of transparency begins to change; in the case of photoelectric tubes or photoelectric multipliers, the electric charge between the electrodes starts to alter the electric field distribution; also, the large amplitude of the output signal causes the internal field strength of the detector to change. All these factors may destroy the linearity of the detector.

Although corrections can be applied to the data collected under non-linear conditions, the non-linear phenomena often produce a cumulative effect which depends on the radiation history. Consequently, to apply accurate corrections is very difficult. In our experiment, we maintained linear operation by limiting the amplitude of the output signal.

The response function of a detector with respect to different energy-level radiation is one of its important performance indicators. Because it is seldom possible to obtain a high-intensity monoenergetic radiation source, particularly a monoenergetic source of neutrons and γ rays, experimental determination of the energy response function is very difficult; quite often it can only be determined by Monte-Carlo calculations, and then verified by a few monoenergetic experimental points. Strictly speaking this method does not produce sufficiently accurate results. Fortunately, a majority of radiation beam measurements involve the measurement of relative waveforms; as long as the energy spectrum does not vary a great deal during the measurement interval, the accuracy requirement of the energy response curve can be relaxed. If conditions permit, the detector should be designed to have a gradual variation in its energy response.

2. Scintillation Detector

Like conventional scintillation detectors, an electric current type scintillation detector is composed of scintillators and photoelectric components.

(1) Scintillators. The majority of scintillators used in radiation beam measurement are organic-based scintillators; the most commonly used scintillators are various types of plastic scintillators. When interacting with charged particles, plastic scintillators are excited and become luminescent. The γ rays will produce secondary electrons from the scintillator, and neutrons will produce recoil protons; therefore, plastic scintillators can also be used to detect neutrons and γ rays. The advantages of plastic scintillators are: fast response time, low cost, and ease of processing into various shapes; such scintillators can be as large as several hundred kilograms or as small as a thin film. The disadvantage is that it has relatively low luminous intensity, but this deficiency can be compensated by increasing the multiplication factor of the photoelectric multiplier.

The performance of a scintillator used in pulsed radiation measurement is shown in Table 2. It can be seen that the half width of the time response of most scintillators is approximately 2-3 ns. The superfast plastic scintillators developed in recent years may have a half width less than 1 ns; the basic technique is to reduce the response time at the expense of luminous efficiency by adding quenching medium to the scintillator to eliminate long-decay-time luminous ingredients. The ST403 plastic scintillator developed by the Beijing Instrument Factory is of this type.

Table 2. Comparison of the performance of Scintillators

scintillator	effective atomic number	density (g/cm ³)	peak wavelength (Å)	coefficient of refraction	rise time (ns)	decay time (ns)	half width of response time (ns)	relative luminous intensity	melting or softening temperature (°C)
NaI (TI)	50	3.67	4100	1.77	30	250	270	2-2.3	650
CsI	54	4.51	5600	1.79	60	710	670	0.7-0.9	620
Anthracene	5.8	1.25	4450	1.62	8	35	35	1	217
Toluylene	5.7	1.16	4400	1.62	1.9	4.5-7	6-8	0.5-0.7	125
PilotB	5.7	1.03	4400	1.58	0.7	1.72	2.4	0.6	75
NEL102A	5.7	1.03	4230	1.58	0.6-0.9	2.4	3.2	0.6	75
NEL11	5.7	1.03	3750	1.58	0.2	1.7	1.2-1.6	0.5	75
NEL11	5.7	1.03		1.58	0.1		0.2	0.05	
NEL150C	5.7	1.06	4400	1.59		3.2	4.3	0.5	75
II II C ₆ -5	5.7	1.06	3800	1.59		0.8	0.5-0.7	0.05	75
II II C ₆ -9	5.7	1.06	3900	1.59	0.4	1.7	1.5	0.3	75
II II C ₁ -1	5.7	1.06	4100	1.59	0.4	2.1-2.5	3.4	0.3-0.4	75
ST401	5.7	1.05	3750	1.58		2-3		0.33-0.4	75-80
ST403	5.7	1.02	4000	1.58		1		0.33	85-80

To understand the mechanism of luminescence of scintillators, one can consult reference [3]. Every scintillator has a certain amount of ingredients with slow luminescence; hence special care must be taken in measuring the trailing edge of the waveform.

The energy response of a scintillation detector is determined by the scintillator. The energy response of neutrons and γ rays of a plastic scintillator has been calculated using Monte-Carlo methods and has also been reported in experimental measurements[4]. The sensitivity of a plastic scintillator $A/(\text{number cm}^{-2}\cdot\text{s}^{-1})$ varies rapidly with γ energy. But if the radiation intensity is measured in units of energy current or energy dosage, then the sensitivity $[A/(\text{MeV cm}^{-2}\text{s}^{-1})$ or $A/(\text{Rad s}^{-1})]$ varies more gradually with energy. This is because the interaction cross section of high-energy γ rays is rather small, whereas the energy of secondary electrons is quite large, thereby providing compensation to a certain degree. Therefore, in measuring γ pulses, the energy current is often used as a measurement unit. Similarly, the variation of scintillator sensitivity with energy for fast neutrons above 1 MeV is also relatively slow. The curve shown in Fig. 3 is calculated by the Livermore Laboratory[4]. The results given in Ref. [5] are in agreement with Fig. 3.

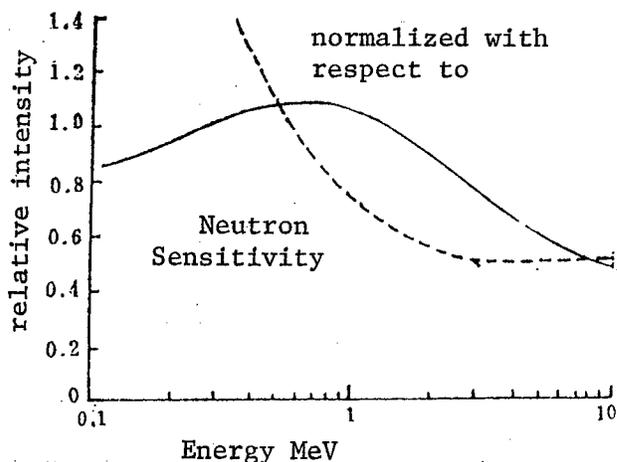

Fig. 3. Monte-Carlo Calculation of the Variation of Photon and Neutron Sensitivity With Energy (Sensitivity is defined as the luminous intensity per unit incident energy; the thickness of crystal is 6 in.)

In measuring a mixed beam of neutrons and γ rays, the scintillator output is the superposition of the effects of neutrons and photons; in this case, the n, γ discrimination technique used in single particle detection is no longer applicable.

Under intense radiation, the scintillator will produce new photoabsorption center, and the detector output will appear to be saturated. Under the

γ radiation in the range of $3 - 8^{20} \text{ MeV}/(\text{cm}^2 \text{ s})$, the non-linearity will exceed 5 percent. The sensitivity will degrade when the cumulative γ radiation has exceeded several tens of kilo-rads; part of the sensitivity loss will be recovered within a short time^[6].

With the advancement of fiber optics technology, the red-light scintillator has been developed which uses optic fibers to transmit scintillation signals over long distances^[7]. At present, the time response of red-light scintillators cannot compare with that of conventional scintillators, and its luminous efficiency is also lower. To transfer the energy of short-wave scintillator to red-light output involves a transfer process which makes it very difficult to reduce the response time. Recently, significant progress has been made in the development of liquid red-light scintillators.

Many laboratories are now engaged in the research of using gallium arsenide as radiating luminescent material. It can emit 8400 Å light and has a response time of less than 1 ns, but it is difficult to build a sufficiently large crystal to be used for direct radiation detection.

(2) Photoelectric Multiplier Tube (PMT). The commonly used multiplier tubes which use focusing-type electrodes can also be used in high-speed pulsed radiation measurement; they include the 56 AVP, the FEU-36, the GDB-50, etc.^[8] In order to output large pulsed signals, the multiplier should operate in a current mode, in which a high voltage, e.g., greater than 500 v, is added to the output stage as well as the last two multiplier stages. This will produce an output pulse current of 300-400 mA within the linear range. The voltages of the other multiplier stages can be adjusted to produce a multiplication factor in the range of $10^5 - 10^8$ for a commonly used 14-stage multiplier tube, and at the same time maintain satisfactory time characteristics.

The half-width time response of a high-speed multiplier is approximately 3-4 ns^[5]. In the literature, the rise time of a multiplier tube is often used as a performance indicator; its value is smaller than the half-width. These values reflect the measured timing characteristics, but for waveform measurement, the half-width or time response function must be used to evaluate the performance of the detector.

To meet the requirements of pulsed radiation measurement, many countries have developed multiplier tubes with large current, fast response, and moderate multiplication factor. Most of these tubes, e.g., the XP1143, the CH T-12, and the GDB-70, have 4 or 6 stages with high inter-stage voltages. The XP1143 uses 6-stage amplification and has side windows; the total voltage can be as high as 7 kV, with the final stage reaching 2 kV. The performance indicators of photoelectric multiplier tubes commonly used in pulsed radiation measurement are presented in Table 3.

Table 3. Performance Indicators of High Speed Photoelectric Multiplier Tubes Commonly Used in Pulsed Radiation Measurement

model number	half-width (ns)	rise time (ns)	maximum linear current (A)	voltage (kV)	multiplication factor
France	3-3.5	2	0.3	3	10^8
France		<2.5	0.3	3	10^8
France	2.5	1.2-2.0	0.3	2.5	10^8
U.S.	2	0.5-1	0.1	6.0	10^7
USSR	4.5	2.2	0.6	2.0	10^7
USSR	4.2-5.5	2-3	1.5-2.5	3.8	10^8-10^9
USSR		0.6-0.7	~ 10	~ 8.0	10^6-10^9
domestic		1.9	0.3	2.5	10^7
France	2	<1	5	7.5	10^4
USSR	3.5	<3	6	6	10^7
domestic	2.0	1.0	5	4.7	10^5
Japan		0.6		2.5	10^4

The glass container of a multiplier tube under γ illumination can produce Cerenkov radiation or fluorescent light which appear as additional background signals. Thus, in measuring high-intensity γ rays, special attention should be given to the shielding of photo-sensitive cathodes.

Other countries have devoted efforts to the research of a composite multiplier tube made of semiconductors and photocells, with the intention of achieving time response less than 1 ns and linearity greater than $10 A^{[9]}$, but the practical application of such a tube has not been reported. Another new tube is the microchannel plate multiplier tube (MCP PMT). As shown in Fig. 4, a microchannel plate is installed between the photo-sensitive cathode and anode; when a voltage is applied, multiplication of photo-electrons takes place. This type of multiplier tube has a transit time of only 2.5 ns and a time response of less than 1 ns; it has been used in the measurement of ultrashort pulses such as laser pulses; its linear current can reach 10 A. But within a single pulse the microchannel plate can only provide 1 nC of electric charge, hence it cannot be used for measuring signals outside the nanosecond range^[10-12].

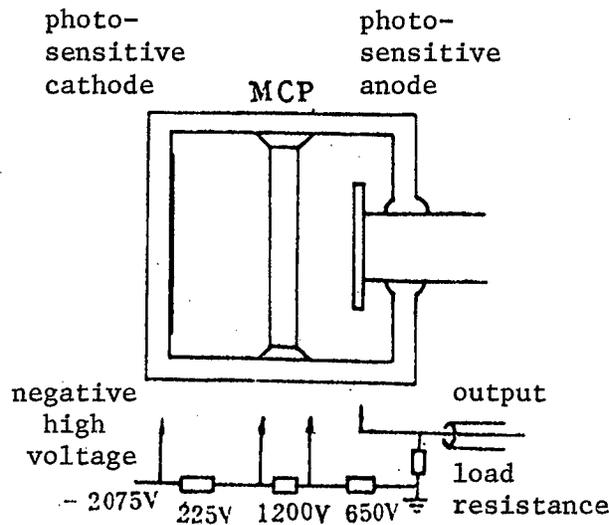

Fig. 4. Schematic Diagram of a Microchannel Plate Multiplier Tube and Typical Voltage Distribution

(3) Photocell. The photocell is also called photoelectric diode, which is a vacuum device with photo-sensitive cathode and anode. With no multiplier electrodes, it is structurally simple and easy to use. Because of the high intensity and strong emission from scintillators in pulsed radiation measurement, sufficient number of photoelectrons are collected by the photocell. The requirement on photocell is fast response and large output current.

The distance between the cathode and anode of a photocell is only a few mm, the applied voltage is greater than 1 kV, the electron transit time between the electrodes is less than 1 ns, and the dispersion time is even smaller. The time response of a photocell is determined by the inter-electrode capacitance and its structure. The flat-plate type photocell meets the requirements of many experiments and is widely used. The co-axial type and transmission-line type photocells have a time response of less than 1 ns and generate large output current [13].

It is a relatively easy task to select a plastic scintillator to match the photocell in terms of structure, sensitivity, and specification; the time characteristics are determined by the scintillator. By using different size scintillators and photocells, it is not difficult to design a radiation detector to operate in the range of 10^{16} - 10^{20} MeV/(cm² s). The performance indicators of photocells used in pulsed radiation measurement are shown in Table 4.

Table 4. Performance Indicators of High-speed Photocells

model number	cell type	cathode area (cm ²)	half-width (ns)	linear current (A)	voltage (kV)
domestic	flat plate	9.6	1.9	10	1.6
domestic	co-axial output	12.6	0.3-0.5	14	2.5
domestic	co-axial output	78.5	1.2-1.8	23	2.5
U.S.	cylinder	diameter 4.3 cm	0.3	30	9
U.S.	flat plate	15	0.75	25	10
U.S.			2	70	10
USSR	flat plate	176	5	15	1
USSR			1.6-1.8	8	1
USSR	transmission-line type	1.5	<0.5	5	2
France	flat plate	0.28	0.1	3	2

Because of its wide range of sensitivity, ease of operation, and good time response, the scintillation detector is used extensively in the measurement of pulsed γ rays and X rays as well as neutron beams. However, since it cannot discriminate between neutron and γ signals, measuring neutron beams in a strong γ background is rather difficult. In some cases, heavy-material shields are used to reduce the γ background, but this may cause widening of the neutron pulse due to secondary interactions^[14]. (to be continued)

3012

CSO: 4008/314

APPLIED SCIENCES

NEW DUAL Z80 NAVIGATION COMPUTER DESCRIBED

Shanghai DIANZI JISHU [ELECTRONIC TECHNOLOGY] in Chinese Vol 12, No 1, 12
Jan 85 pp 5-8

[Article by Yu Shiquan [0205 2514 2938], Zhang Chunbao [1728 2504 1405] and
Wu Shuwei [6762 2885 0251], Shanghai University, Academy of Engineering:
"Dual Microprocessor Structure Used in Navigation Computer"]

[Text] I. Overview of Dual Processor Structure

There are many advantages to multi-processor system structures. First, the performance/price ratio is obviously higher than with single CPU systems. The magazine COMPUTER REVIEW once made some calculations, producing the curve shown in Figure 1. The performance/price ratio of single CPU systems, if one ignores the cost factor added for interconnecting the processors, the ideal performance/cost ratio should be a straight line, and the actual performance/price ratio descends much less than for single CPU systems.

Figure 1.

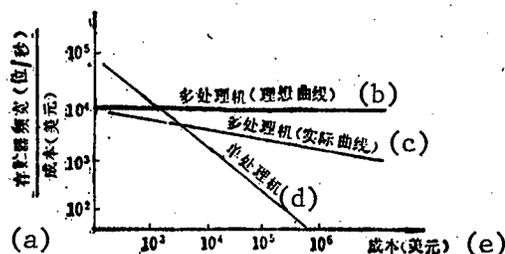

- KEY: (a) $\frac{\text{memory frequency width (bits/sec)}}{\text{cost (US\$)}}$
- (b) multi-processors (ideal curve)
- (c) multi-processors (real curve)
- (d) single processor
- (e) cost (US\$)

Next is the high processing speed of multi-processor systems. At present, the chief method of raising single CPU calculation speed is to increase clock

speed, but that is limited by certain conditions as well as its own limitations. When the single CPU cannot satisfy the calculation of large amounts of real time sensitive data, one can only solve this with multi-processor structures.

Third, when multi-processor systems are using a distributed structure, each processor constitutes a module, which facilitates multiple installations and incorporates a series of advantages from modularization. This kind of system is convenient for LSI or VLSI implementation, having extremely good structural flexibility and providing advantageous conditions for system expansion.

Seeing the advantages of multi-processor systems, we used multiple microprocessor structure on the navigation computer developed for the Shanghai Channel Navigation Bureau. Because the mathematical model for this microcomputer navigation system is huge, calculations are complex, there is a real time emphasis, there is a great deal of data to be handled, and there is a software real time clock in the system that generates frequent interrupts, this requires a high system processing speed. We fully resolved this problem by using a dual microprocessor structure.

This system is a heterogeneous multi-processor system, using two single board microcomputers in a master-slave configuration. The master-slave dual processors operate in parallel, can communicate with each other, and can each do different functions. The master processor handles keyboard input, display output, printer output, operation of the software real time clock, data collection, and communication between the two processors; the slave processor is solely responsible for the executive and conversion of all calculations. Dual processor communications rely on a Z80 PIO parallel input-output interface and specific communication formats. This allows the master CPU to transfer the various numeric processing functions to the slave CPU, while the slave CPU will then report the arithmetic results in a timely manner to the master CPU.

This system will be primarily used in coastal marine navigation locations. It can accommodate special vessels by providing accurate real time ship position coordinates and indications of ship deviation for the special tasks of off-shore channel surveys, oceanographic research, the laying of ocean floor cables, oil exploration, channel dredging, and arms testing. It can also provide accurate position and deviation indications for aerial photography, aerial prospecting, etc.

Under the premise of preserving the original Z80 single board computer's monitor program ZBUG, we redefined the single board's keyboard and wrote a new monitor program ZBUB1 that works completely through software. We also wrote a new monitor program ZBUG2 for the processor and installed program modules and subroutines to implement various calculations, for a total of 8K bytes. The total number of programs in this system occupy 12K bytes, all burned into an EPROM.

II. Operating Principles and the Mathematical Model for the Navigation Computer

This system can process both straight and curved lines of navigation, it can accept shore beacon sites and wavelengths from the keyboard as parameters for calculation, one can input from the keyboard the values of Gaussian coordinates x, y or the values B, L of latitude and longitude coordinates, and it can also cross convert. It can display in real time, and print by clock coordinate values, time, and deviation distance.

Input data for this system comes from radiolocation instruments. Four points of known coordinates on shore are outfitted with radiolocation instrument beacons, and the beacons transmit similar signals differentiated in time. The system can measure the phase difference of the times the signals from any two beacons reach the ship's location recording instruments, as well as output the value for the phase difference between θ_1 and θ_2 according to the location instruments. Any phase difference in θ_1 and θ_2 corresponds to the difference in distance from the ship's position to the two beacons, and makes a hyperbola with the trace of points equivalent to the difference between the two beacons. Therefore, the intersection of the hyperbolae corresponding to θ_1 and θ_2 is the ship's position at that instant. The principles are shown in Figure 2.

Figure 2.

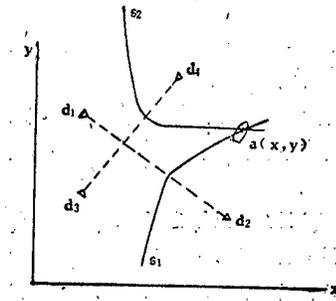

After determining the ship's coordinates, by entering the course-line equation established by the course-line parameters and after mathematical operations one obtains the directional distance of deviation between the ship's position and the course-line. Because the calculations for the real time set up of the hyperbolic equation and solving for the point of intersection of the hyperbolae are very complicated, it is difficult to give an instantaneous display. Therefore, we varied and derived the mathematical model, and under the premise of satisfying the technological requirements made the calculation execution times as short as possible.

III. System Design of the Navigation Computer

Referring to theories of multi-processor system construction and based upon the technical targets provided by the users, and taking into consideration the precision and speed of the various calculations demanded by this design as

well as the cost of batch production and maintainability, we decided on a dual single board computer structure to make up the dual processor system. The logical system schematic is shown in Figure 3.

Figure 3.

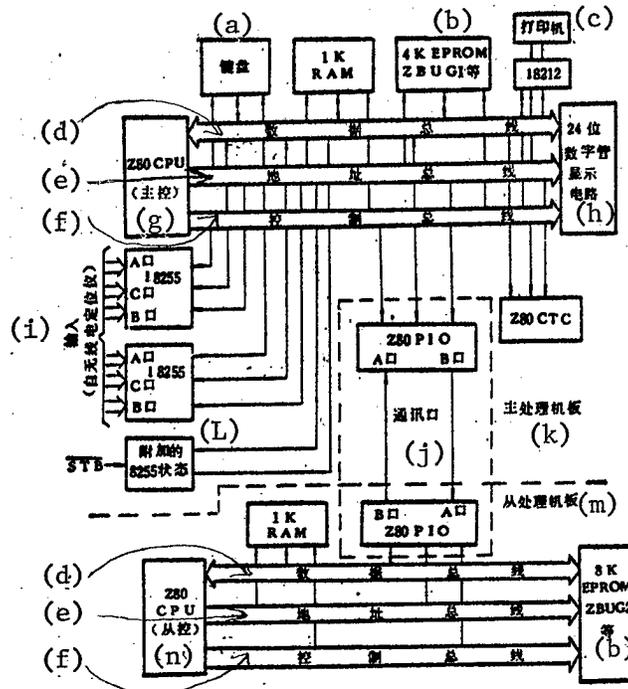

- KEY:
- (a) keyboard
 - (b) [English text, then] etc.
 - (c) printer
 - (d) data bus
 - (e) address bus
 - (f) control bus
 - (g) master control
 - (h) 24 bit digital tube display circuit
 - (i) input (from radiolocation equipment)
 - (j) communication port
 - (k) master processor board
 - (l) supplementary 8255 state
 - (m) slave processor board
 - (n) slave control

1. Dual processor system structure

The master CPU is composed of a Z80 single board computer, which we call the master controller and I/O processing board. It has been extended with several input and output interfaces and logic displays. The master controller has sole responsibility for all controller and for peripheral I/O processing, like numerical display, printer output, receiving the phase difference signal from the radiolocation instrumentation, etc.

We used from the CPU only the Z80 CPU, 1K byte of RAM, 8K bytes of EPROM, a Z80 PIO, etc, and the monitor program of the board and the calculation processing routines are all burned into an 8K EPROM. We revised the EPROM of the board and used the technique of address "relocation" to enable the EPROM to "relocate" to the required address. The slave processor is only responsible for the conversion and processing of the various calculations.

2. Communications between the two processors

Because we are using two processors with parallel operation the master and slave processors exchange information via intercommunication. Information is exchanged through two interconnected Z80 PIOs. For both the master and slave CPUs, port A of the PIO is used in input mode (i.e., mode "1") and port B in output mode (mode "0"). The STE and RDY signal lines of the two PIO's are cross connected, and "handshake" with each other to control the transmission of each byte. Data and information is sent in data block mode, that data block mode being as follows:

overall length	type	data	checksum
----------------	------	------	----------

The process of communication between the master and slave processors is as follows: when the master processor needs to output data all it has to do is to actuate its own PIO and output the data through port B, at which time the connecting signal is sent out on the "handshaking line." After the slave CPU's PIO receives this connecting signal it sends out an interrupt request and this data block is entered into the system input buffer by the interrupt service subroutine. At the same time, the CPU schedules the corresponding calculation module for processing according to the length and type of the data block. When the calculation routine has finished execution, the CPU stores the operation result in an output buffer. Then, in the same way, it sends the data through port B of the PIO to port A of the master processor's PIO, where it is reception of the data is different.

3. Interface with the radiolocation instruments

Considering that what is input from the radiolocation instruments is the digital quantity of the phase difference, we therefore selected two Intel 8255A's for input interfacing. The two I8255A's are both set in "0" mode, that is, the basic input/output mode, which allows ports A,B, and C to be input ports and permits simultaneous input of 48 bits, or 12 bit BCD code. This suites perfectly the requirement that the radiolocation equipment send a 12 bit BCD coded phase difference each time.

4. Data display circuits

Based on design requirements, we needed a 24 bit display tube, where figure 4 is the data display logic schematic. We used the principles of dynamically scanned display, and based on the requirements of navigation display we divided the display tube into three groups, each group having eight. The three group display tubes latch corresponding seven segment numerals respectively by three 74LS273's, selection of the particular group and segment

values are controlled respectively by the CPU address and data busses, which send in parallel the decoded segment values to the eight display tube annodes. In addition, a 74LS273 is used in conjunction to latch the gate signal for each tube number for the first through eighth display tubes in the three groups of display tubes. In this way, all we need to do in software is to dynamically scan 8 times, by which action we can scan all 24 display tubes in one pass. This scheme saves time in scanning and turning on the lights, as well as saves hardware unlocking, which is advantageous for batch production.

Figure 4.

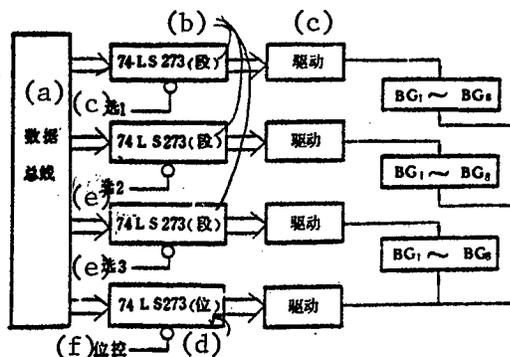

- KEY: (a) data bus
 (b) segment
 (c) driver
 (d) bit
 (e) select
 (f) bit control

5. Printer interface

We decided that a printer would be part of the computer as printout equipment for the navigation computer, which uses an I8212 as a printer interface. That I8212 is controlled by printer service routines, which output the data stored in the internal buffer through the printer.

6. Software clock

We use channel 3 of the Z80 CTC on the master processor board to produce real time clock interrupts, which generates an interrupt every 25 ms. Clock interrupt handling routines are responsible for the operation of the software clock.

IV. Master Processor Board Software Development

We wrote a new 2K byte monitor program ZBUG1 for the master processor board, which we burned into the EPROM from 0800h to 0FFFh.

1. The structure of ZBUG1 routines

In order to retain the functions of the original single board computer we kept the original single board computer monitor program, ZBUG, and developed a new monitor, ZBUG1. Its overall structure may be divided into six portions: system initialization routines; display driver routines; keyboard scanning and decoding routines; processing routines for various functions keys (command keys); interrupt processing routines; other peripheral driver service routines, like printer driver routines and software real time clock service routines, etc. The flowchart for ZBUG1 is shown in figure 5.

Figure 5.

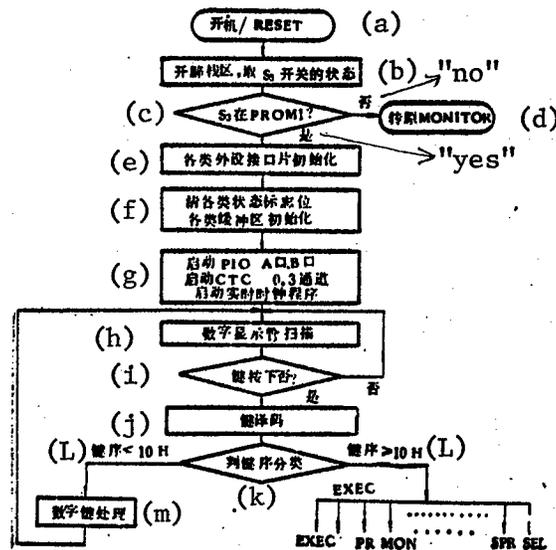

- KEY:
- (a) on-off/RESET
 - (b) initialize stack area, get S_3 switch state
 - (c) is S_3 in PROM1?
 - (d) transfer to original monitor
 - (e) all peripheral interface chips initialized
 - (f) request zone bit; all buffers initialized
 - (g) activate PIO ports A,b; activate CTC channels 0,3; activate real time clock routines
 - (h) digital display tube scan
 - (i) has a key been pressed?
 - (j) keyboard decoder
 - (k) decide key sequence category
 - (L) key sequence
 - (m) numeric key processing

All routines were written in modular form, and all are independent, which aids in maintenance. For all routines the core is display scan drivers and keyboard scan decoders, with numeric keys and function keys as two branches.

Sixteen numeric keys and 12 command keys are distinguished by ZBUG1, which are then classified and transferred to their corresponding service routines. The function keys in ZBUG1 can be largely classified into four categories:

- a. Function keys that provide various initial parameters needed for navigation: like STM (set software clock value), and SSE (send course parameters).
- b. Command keys that select a certain execution scheme and execute the function: like SEL (select latitude/longitude coordinates for real time display of ship position), SXB (exchange Gaussian coordinates and latitude/longitude coordinates, to which add the A key to change back), EXEC (does an execution function to correct without coordinates), and EXEC1 (does an execution function to correct with coordinates).
- c. Functions to provide revised course parameters: like MOVE (course translation), SRD (send beacon and wavelength parameters), and MON1 (return after revision).
- d. Functions to provide real time printing of data: like SPR (sets printing time intervals), and PR (immediate printing of data).

2. Overview of function key handling routines

In order to understand this together with the later section on the ZBUG2 module, and consequently understand the entire operational process of the system, we will here only make a general description.

It can be seen from Figure 5 that after moving through the keyboard decoding routines (DECKY), processing routines for the SSE, SEL, SXB, EXEC, EXEC1, MOVE, SRD, etc, keys are all based on their functions, and in order for data in the data buffer to suit its type (determined by use), overall length, and checksum, it forms a data block according to a specified format. Then, it calls the PIO port B output service routines to communicate with the slave processor. After output, it returns to the display control program.

The STM key enters the current input parameters into the register unit corresponding to the software real time clock. The software real time clock is automatically activated by interrupts.

The SPR key sets the real time printing interval based on the the input constant, and the PR key immediately prints various data. When printing is finished it moves the program breakpoint and continues execution.

After processing routines for the numeric keys transform the numbers into ASCII characters, they are entered into the data buffer, and when needed set the corresponding marking bit. Calculations of all sorts use quadruple length floating point operations, so therefore use of ASCII characters is more convenient than decimal.

V. Slave Processor Board Software Development

Slave processor board software is divided into three large categories according to design requirements: the monitor program ZBUG2, all calculation processing and conversions between calculations, and linking programs and subroutine libraries (handling four byte floating point operations like addition, subtraction, multiplication, division, powers, root extraction, trigonometric functions), for a total of 8K bytes.

The entire flow awaits interrupts--interrupt processing--execute calculations--and data output and return all basically await new interrupts. After the communication of data, the controlling program jumps to the individual calculation execution routines according to the data types. Program flow is shown in Figure 6.

Figure 6.

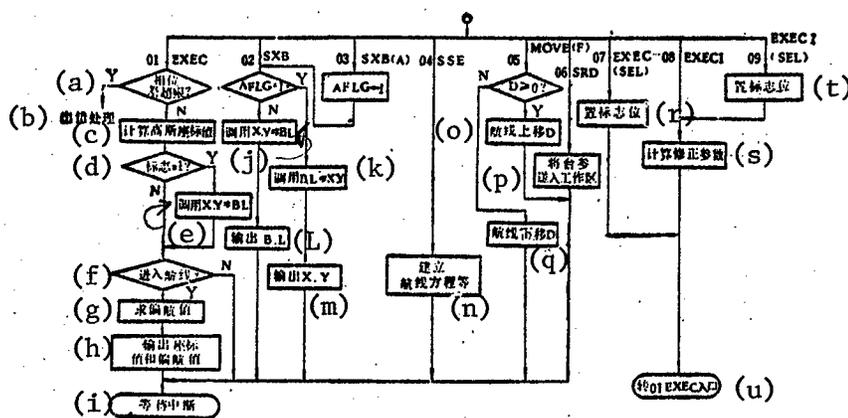

- KEY:
- (a) phase difference past limit?
 - (b) error handling
 - (c) calculate Gaussian coordinate values
 - (d) index=1?
 - (e) call X,Y B,L
 - (f) enter course?
 - (g) request value of course deviation
 - (h) output coordination and deviation
 - (i) awaiting interrupts
 - (j) call X,Y B,L
 - (k) call B,L X,Y
 - (l) output B,L
 - (m) output, X,Y
 - (n) set up course-line equation
 - (o) course-line above, move to D
 - (p) put beacon parameters into working area
 - (q) course-line below, move to D
 - (r) set index bit
 - (s) calculate correction parameters
 - (t) set index bit
 - (u) jump to 01 EXEC start

1. ZBUG2 monitor program

The ZBUG2 monitor is responsible for the control and supervision of the slave processor operations. It is comprised mainly of initialization routines, interrupt service subroutines, and communications processing routines.

Initialization routines primarily clear various marking areas and buffers, set operation modes for all PIO channels and do initial activation (enables response to communication interrupt requests), as well as begin waiting for communication interrupts.

PIO interrupt communication processing routines are primarily responsible for communication links between the slave and master processor boards. When data blocks have been sent, they break up into the corresponding calculation processing routines according to the type and value of the information.

For output of communication data, the various calculation processing routines send the values of their results to output buffers in internal memory, where communication processing routines organize it according to the information block format. Then it is output to the master processor's port A via the PIO's port B. After output an awaiting interrupts state is entered to facilitate reception of the next command and data to be sent from master processor.

2. Various calculation and execution routines

All calculations use quadruple length floating point, an 8 bit characteristic (including a 1 bit sign bit), and a 24 bit mantissa (including a 1 bit sign bit). The range of numerical expression is from 1.7×10^{38} to 2.9×10^{-39} .

The program system uses hierarchical modular structure, where external level modules may make one-way calls to inner levels. Module communication between levels and within same levels uses a uniform format, and communication must be done through message areas. Internal modules are calculated entirely through floating point operations, and for some data bases a check is first done for legality before the operation.

Reference Works

- [1] Su Dongzhang [5685 2639 5445], "Computer System Structure," Beijing: National Defense Industry Publishing, 1981, 326-327.
- [2] Yu Shiquan [0205 2514 2938], et al, "Developing a New Monitor Program for a Z80 Single Board Computer," ELECTRONIC TECHNOLOGY, 1983.2.

12586
CSO: 4008/1010

APPLIED SCIENCES

SUPERHEATED STEAM'S DENSITY COMPENSATION FOR FLOW MEASUREMENT

Shanghai HUAXUE SHIJIE [CHEMICAL WORLD] in Chinese Vol 26, No 2, 20 Feb 85
pp 61-63

[Article by Xu Guanquan [1776 7070 3123]

[Text] Superheated steam is an important energy source for chemical industry and metallurgy production and is an additive in chemical industry and metallurgy production and is an additive in chemical reactions. It is also an important indicator for the quality of management and production process control. In order to carry out cost accounting and to use steam in a controlled manner, it is necessary to accurately measure and quantify the superheated steam. At present, there are many compensation methods for steam flow measurement. But, with overelaborate calculations and expensive meters, they are all complicated and hard to calibrate. The method described here uses DDZ-II model electric meter with combined units, which is moderate in price and easy to link to computer.

Design Principle

The general method for steam flow measurement is by using apertured plate as flow regulation element (see figure 1.) Its flow equation is:

$$G_0 = K \sqrt{\Delta P} Y_0 \quad (1)$$

where G_0 is designed flow of steam (Kg/hr), Y_0 steam density under designed condition (Kg/m^3), ΔP pressure difference between the two sides of apertured plate (mm water) and K a constant related to the structure of apertured plate.

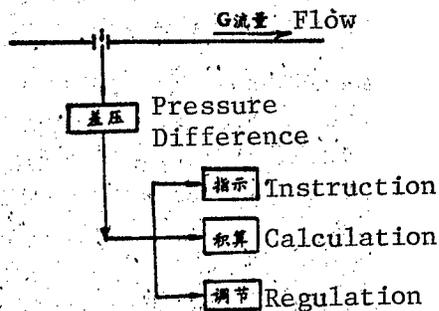

Figure 1. Schematic Diagram of Flow Measurement of Steam

But steam density γ changes with temperature and pressure. When the temperature and pressure of the steam to be measured are constant, then the steam density will be constant. However, in real situation, the temperature and pressure of superheated steam are subjected to various kinds of perturbation and are constantly changing, which results in the constant changing of steam density. Therefore, the density under designed condition and the density in actual situation are different and the flow equation of steam in actual situation should be:

$$G_I = K \sqrt{\Delta P_I \gamma_I} \quad (2)$$

where G_I is steam flow in actual situation (Kg/hr), γ density of superheated steam in actual situation (Kg/m³) and ΔP_I pressure difference between the two sides of apertured plate (mm water).

In order for $G_0 = G_I$, the following can be derived from eqs. (1) and (2):

$$\Delta P_0 = \Delta P_I \cdot \frac{\gamma_I}{\gamma_0} = \Delta P_I \cdot \psi \quad (3)$$

$$\psi = \frac{\gamma_I}{\gamma_0} \quad (4)$$

ψ in the equation is density correction coefficient of flow.

According to reference 1, the semi-empirical correlation of density with temperature and pressure when the pressure of superheated steam is between 2 and 110 Kg/cm² is as follows:

$$\gamma = 0.52 P / (1 - 0.0026 \Delta t) \quad (5)$$

where P is absolute pressure of steam (Kg/cm²), Δt degree of superheating, i.e. the difference between actual and saturation temperature (°C).

From eq. (4):

$$\begin{aligned} \psi &= \gamma_I / \gamma_0 \\ &= \frac{0.52 P_I / (1 - 0.0026 \Delta t_I)}{0.52 P_0 / (1 - 0.0026 \Delta t_0)} \end{aligned}$$

Because the relationship between absolute pressure P and apparent pressure p is:

$$P = 1 + p$$

so

$$\psi = \frac{1 + p_I / 384.62 - \Delta t_I}{1 + p_0 / 384.62 - \Delta t_0}$$

$$= \alpha / \beta$$

(6)

in which:

$$\alpha = \frac{1 + p_I}{1 + p_0}$$

$$\beta = \frac{384.62 - \Delta t_I}{384.62 - \Delta t_0}$$

where Δt_r is degree of superheating of steam in actual situation ($^{\circ}\text{C}$), Δt_0 degree of superheating under designed condition, t_p saturation temperature of steam under designed condition ($^{\circ}\text{C}$), P_I apparent pressure in actual situation (Kg/cm^2), p_0 apparent pressure under designed condition (Kg/cm^2), α pressure correction coefficient, B temperature correction coefficient.

Equation (6) is the density correction equation for superheated steam.

Under the actual operating situation of boiler room in our plant, the steam temperature t_I is $160\text{--}240^{\circ}\text{C}$, pressure p_I is $4\text{--}10 \text{ Kg}/\text{cm}^2$, pressure difference ΔP_I at maximum flow is 2500 mm water and the apertured plate is designed for t_0 of 180°C and pressure p_0 of $8 \text{ Kg}/\text{cm}^2$. When temperature t_I is 240°C and pressure p_I is $4 \text{ Kg}/\text{cm}^2$ in actual operating condition, from table it can be obtained that $\gamma_I = 1.682 \text{ Kg}/\text{m}^3$ and $\gamma_0 = 3.962 \text{ Kg}/\text{m}^3$. Without correction, the error δ should be:

$$\begin{aligned} \delta &= (1 - G_I/G_0) \times 100\% \\ &= \left(1 - \sqrt{\frac{\gamma_I}{\gamma_0}}\right) \times 100\% \\ &= \left(1 - \sqrt{\frac{1.682}{3.962}}\right) \times 100\% \\ &= 34.8\% \end{aligned}$$

When correcting by using eq.(6), from table it can be obtained that the saturation temperature of steam under designed condition $t_p = 169.61^{\circ}\text{C}$ and flow correction coefficient is:

$$\begin{aligned} \psi &= \frac{1 + p_I / (384.62 + t_I - 169.61)}{1 + p_0 / (384.62 + t_p - 169.61)} \\ &= \frac{1 + p_I / (384.62 + t_I - 169.61)}{1 + 8 / (384.62 + 180 - 169.61)} \\ &= 0.111(1 + p_I) / (0.54432 + 0.002532t_I) \quad (7) \\ &\quad (\Delta t_r = t_I - t_p, \Delta t_0 = t_0 - t_p) \end{aligned}$$

where t_I is temperature of steam in actual situation ($^{\circ}\text{C}$), t_0 temperature of steam under designed condition ($^{\circ}\text{C}$). Then, the relative error after correction δ' is:

$$\delta' = (1 - G_I/G_0) \times 100\%$$

From eqs.(3) and (4):

$$\delta' = \left(1 - \sqrt{\frac{1}{\psi}} \cdot \sqrt{\frac{\gamma_I}{\gamma_0}}\right)$$

Substituting ψ with eq.(7), then:

$$\begin{aligned} \delta' &= \left(1 - \sqrt{\frac{0.54432 + 0.002532 t_I}{0.111(1 + p_I)}}\right) \\ &\quad \cdot \sqrt{\frac{1.682}{3.962}} \times 100\% \\ &= \left(1 - \sqrt{\frac{0.54432 + 0.002532 \times 240}{0.111(1 + 4)}}\right) \\ &\quad \times \sqrt{\frac{1.682}{3.962}} \times 100\% = 6.2\% \end{aligned}$$

From the results of the two methods described above, it can be seen that the difference between the relative errors before and after correction δ and δ' is very large. Therefore, this method of density compensation for superheated steam is useful.

Methods

The method described above can be carried out by using either computer or regular meters. When using regular meters, the following conditions have to be satisfied:

1. $\alpha \leq 1$;
2. $\beta \leq 1$;
3. The upper limit of measurement for pressure difference transducer should meet the condition that the ratio of maximum flow signal to minimum temperature signal is no smaller than K_p/K_t , i.e.:

$$\Delta P_{\max} \geq \frac{K_p}{K_t} \cdot \frac{t_{\max}}{384.62 - \Delta t_m} \cdot \Delta P_M \quad (8)$$

where t_{\max} is meter's upper limit for temperature measurement ($^{\circ}\text{C}$), Δt_m difference between saturation temperature and lowest temperature that needs correction ($^{\circ}\text{C}$), ΔP_{\max} meter's upper limit for pressure measurement (mm water), ΔP_M pressure difference at maximum flow (mm water), K_p pressure transformation coefficient, K_t temperature transformation coefficient.

To match meter with mathematical model, let: $\Delta P_{\max} \geq \Delta P_M$, $t_{\max} \geq 1 + 0.0026 \Delta t_m$, and α , β should be rewritten as:

$$\alpha = K_p (S_p + p_t / P_{\max}) \quad (9)$$

$$\beta = K_t (S_t + t_t / t_{\max}) \quad (10)$$

$$K_p = P_{\max} / (t + p_0) \quad (11)$$

(p_{\max} : maximum apparent pressure under operating condition)

$$K_t = t_{\max} / (384.62 - \Delta t_m) \quad (12)$$

$$S_p = 1 / P_{\max} \quad (\text{pressure transport coefficient}) \quad (13)$$

$$S_t = (384.62 - t_p) / t_{\max} \quad (\text{temperature transport coefficient}) \quad (14)$$

then, according to eq.(3):

$$\begin{aligned} \Delta P_0 &= \Delta P_{I0} \\ &= \Delta P_I \cdot \frac{K_p (S_p + p_t / P_{\max})}{K_t (S_t + t_t / t_{\max})} \quad (15) \end{aligned}$$

Eq.(15) is flow density correction formula in actual operation. K_p , K_t , S_p , S_t , p_{\max} and t_{\max} are all known constants. It is necessary only to measure p_I , t_I and p_{I0} to obtain the actual flow of superheated steam on-line.

Selection of Meters

In selecting meters, the transport of temperature and pressure transducers as well as the problem of transformation coefficients of pressure difference transducer and arithmetic unit of computer have to be considered.

In this method, the DDZ-II model electric meter of combined units³ was used, which is consisted of DBW-130 temperature transducer, DBY-131 pressure transducer, DBC-312 pressure difference transducer. Platinum resistance WZB-210 and standard apertured plate were used for temperature measurement and flow regulation element respectively. The multiply-divide unit DJS-03, square-root calculator DXS-202 and strip-chart automatic balance recorder XWD1-101 were also used.

According to the boiler condition of our plant, it was calculated by using above equations that upper limit of temperature measurement $t_{\max} = 455.01^{\circ}\text{C}$, upper limit of pressure difference measurement $P_{\max} = 2952.2 \text{ mm water}$. Therefore, the following can be selected from a series of meters: temperature transducer ($t_{\max} = 500^{\circ}\text{C}$), pressure transducer ($P_{\max} = 10 \text{ Kg/cm}^2$) and pressure difference transducer ($P_{\max} = 3000 \text{ mm water}$). The flow measurement of superheated steam in actual operation is illustrated in figure 2.

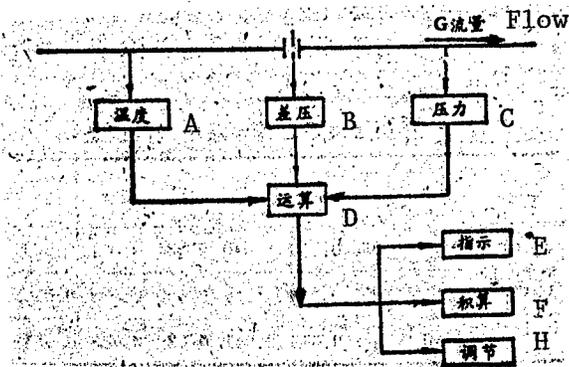

Figure 2. Schematic Diagram of Density Compensation for the Measurement of Superheated Steam.

- A: Temperature
- B: Pressure Difference
- C: Pressure
- D: Operation
- E: Instruction
- F: Calculation
- H: Regulation

Conclusions

This method involves little calculations and is simple in construction. Better results were achieved in our plant. The disadvantage is that semi-empirical formula is used so it is a kind of compensation with inherent error. In future applications, this error will have to be corrected by further mathematical modelling study in order to raise measurement accuracy.

Besides the errors caused by temperature and pressure perturbation in the process of measurement, different degree of error can also be caused by the wear and tear of apertured plate, the improper installation of apertured plate and pressure pipe, the excessive range of transducer as well as the low accuracy of meter itself. Caution should be exercised with regard to these aspects.

Acknowledgement: I am indebted to professor Shao Huihe [6730 1920 7729] of the Eastern China Chemical Engineering College for his enthusiastic guidance.

References:

1. Lin Kaihua, Automation and Meter in Chemical Industry, 7(12), 819 (1982).
2. "Design Manual for Automated Control in Petrochemical Industry," 180 (1980).
3. Wu Qinqin, "Electric Regulation Meters," Chemical Industry Publications, 7, 36, 67 (1980).

12922

CSO: 4008/1011

APPLIED SCIENCES

TITANIUM-NITROGEN ION BEAM INJECTION STUDIED

Lanzhou LANZHOU DAXUE XUEBAO (ZIRAN KEXUE BAN) [JOURNAL OF LANZHOU UNIVERSITY (NATURAL SCIENCE EDITION)] in Chinese Vol 20, No 4, 28 Dec 84 pp 123-124

[Article by Jiang Xingliu [3068 5281 3177], He Lianlong [6320 6647 7893], Jiang Songchuan [1203 2646 1557] and Chen Kefan [7115 0344 0416]]

[Text] The ion beam injection technology has enhanced the development of semi-conductor devices and circuits and brought semi-conductor production into a new era of ultra-large scale integrated circuit. The emergence of ion injection metallurgy will revolutionize the metallurgical industry and machining industry. The generally used continuous flow, low intensity ion beam injection technology requires complicated equipment with long cycle and low efficiency. Based on previous works, the experimental results of pulse titanium-nitrogen ion beam injection into steel were discussed in this article.

It is well known that titanium alloys and titanium compounds have such excellent properties as heat resistance, corrosion resistance, great strength and great hardness. If a layer of titanium-nitrogen ions is injected onto the surface of steel to form TiN and Ti₂N layer, it should greatly improve the properties of the material. Preliminary studies on pulse titanium-nitrogen ion beam injection onto steel surface was carried out by using multiple plate electrode capacitor for low pressure gas, which is based on the principle of progressively increasing electric field.

The distribution profile of titanium, nitrogen, oxygen and carbon within the steel was analyzed by PHI-550 electronic spectroscopy (Figure 1). It can be seen that titanium and nitrogen have similar atom concentration distribution versus depth. The concentration distributions of titanium and nitrogen are also similar on the picture from surface line scanning. The results from corrosion resistance experiments confirm that corrosion resistance and hardness of the injected surface have been notably improved.

Because the ion beam used in the high-power-density, nanosecond pulse beam (10^8 W/cm²), the injected surface has been subjected to rapid heating and cooling, which results in the formation of an amorphous layer of great strength. Figure 2 is the scanning electron microscope picture of the interface between injected area and base material. On the right half

of the picture, the amorphous layer covering the surface of No 45 steel can be seen.

Figure 1. Distribution Profiles of Iron, Titanium, Nitrogen, Oxygen And Carbon. The Ordinate Represents Atom Concentration Percentage. The Base Material is No 45 Steel.

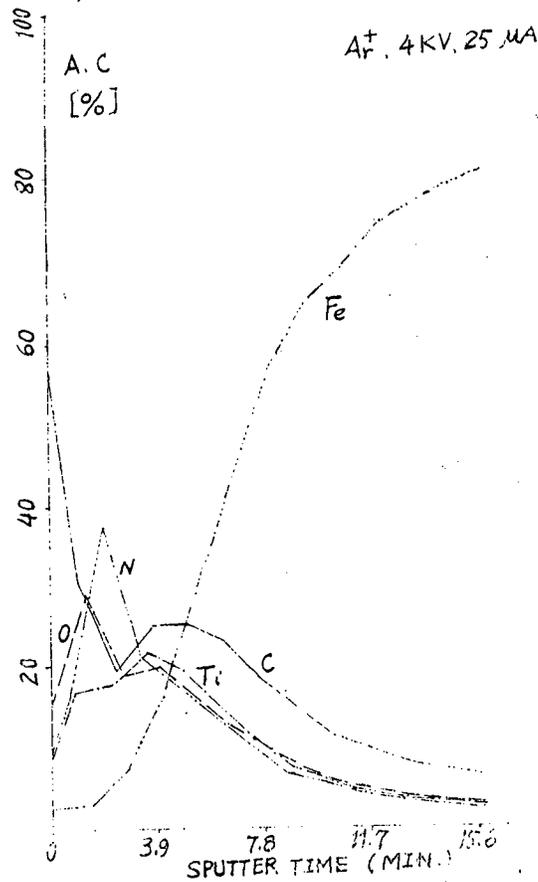

Figure 2. The Secondary Electron Image of the Interface between Ion-beam Injected Area and Base Material by Scanning Electron Microscope.



Acknowledgement: The Spectroscopy Section of the Lanzhou Institute of Chemical Physics provided the Auger electronic spectroscopic analysis. Scanning electron microscope picture of experimental sample was taken by Shen Mingzhi [3088 2494 2535].

References:

1. Beijing Municipal Radiation Center, "Principles and Techniques of Ion Beam Injection," Beijing Publication, 1982.
2. Jiang Xingliu, Chen Kefan, and Po Yubo, "Proceedings of 2nd Sino-Japanese Symposium on Accelerator and Its Applied Sciences," October 1983 (Lanzhou), pp 336-338.
3. Noriaki Kurita et al., JPN Journal of Applied Physics, Vol 12, No L (1982) pp 33-38.

12922
4008/1011

APPLIED SCIENCES

HIGH-POWER ND: GLASS LASER AND TARGET CHAMBER SYSTEM AND AN EXPERIMENTAL STUDY OF LASER PLASMA X-RAY

Hefei: ZHONGGUO KEXUE JISHU DAXUE XUEBAO [JOURNAL OF CHINA UNIVERSITY OF SCIENCE AND TECHNOLOGY] in Chinese Vol 15, No 1, Mar 85 pp 30-36

[Article by Wu Hongxing [0702 7703 5281], Guo Dahao [6753 1129 3185], Zhou Yusheng [0719 2810 3932], Zhang Limin [1728 4539 2404], He Weimin [0149 5898 3046] and Dai Yusheng [2071 1342 3932]:

[Text]

Abstract: The structure and characteristics of a high power Nd:glass laser and target chamber system is described. The system has been used in the experimental study of laser plasma X-ray (LPXO) to obtain photographs of hydrogen-like and helium-like X-ray spectra of Mg and Na. The electron temperature reached 10^6 K. The results demonstrated that the Nd:glass laser and target chamber system can be used in the study of laser plasma and other related subjects.

I. Introduction

In the last decade, research institutes in the United States, the Soviet Union, Japan, and West Germany and the Shanghai Institute of Optics and Fine Mechanics have all built laser systems of increasingly greater power (10^{11} - 10^{13} W). The main goal is to achieve laser induced nuclear fusion in the heating of spherically symmetric plasma. In addition to the laser fusion application, such high power laser systems can also play an important role in other research areas. For example, they may be used in frequency conversion and produce intense X-ray, they may be used in the study of multiphoton processes and in fluorescence attenuation, and they may also be used in the generation of extremely high pressure and temperature and in the study of the interaction of intense laser light with matter.

To study the characteristics of high power laser and to develop applied research using high power lasers, we have built a high power Nd:glass laser system and the target device is basically completed. Using this system we have for the first time studied laser plasma X-ray and obtained photographs of the X-ray spectra.

II. The High-Power Laser and Target Chamber System

The overall layout of the system is shown in Fig. 1. The total optical path is about 30 m. In the figure OSC denotes the laser oscillator, $A_1 \sim A_7$ are laser

amplifiers; DEOS is a dual Pockels' cell electrooptic switch; LTGS is the laser trigger spark gap; FRI is a Farady magneto-optic isolator; M is a total reflection mirror for 1.06 μ m wavelength; SF is a spatial filter; FI is a Frisnel isolator; M_1 , M_2 and M_3 are total reflection or partial reflection mirrors for 6328 \AA ; V is the vacuum target chamber;

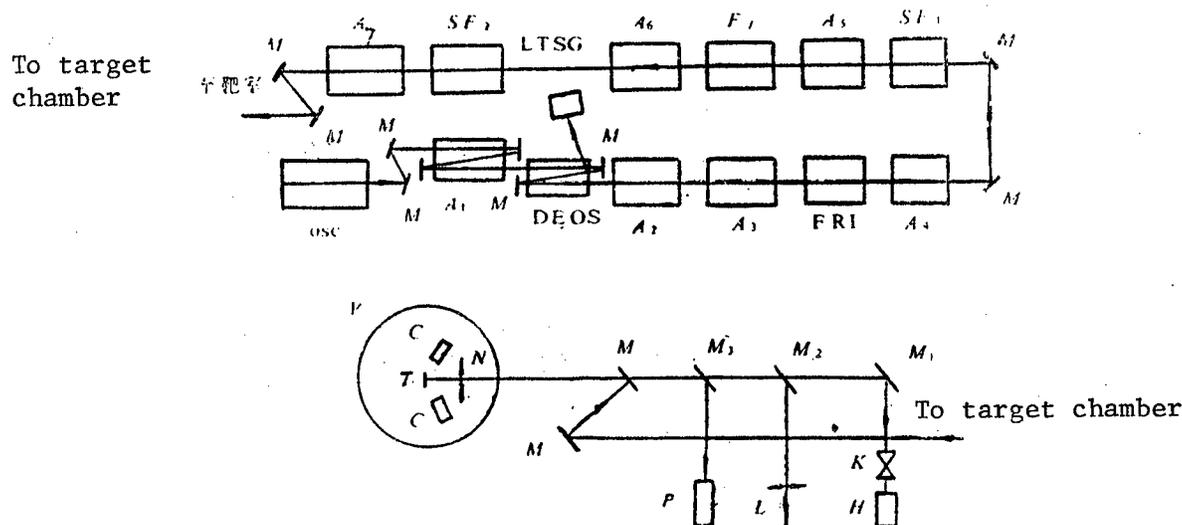

Fig. 1. Optical path diagram of the high power laser and target system

N is a nonspherical focusing lens; T is the target; C is the crystal spectrometer; P is the parallel light pipe; L is a lens; H is a He-Ne laser, and K is a beam expander.

1. Laser oscillator

The laser oscillator is a Q-switched YAG laser⁷ using a pair of 45° LiNbO_3 crystals. It has two pumping lamps, an ellipsoidal focusing chamber, and cooling water for the lamps and the rod. It may be operated in the one-shot mode or at a repetition rate up to 5 Hz. The resonance cavity is a plano-plano cavity, the reflectivity of the output mirror is 40 percent, the output is a pulse compressed Q-switched polarized light, and the mode selection is achieved with a 2 mm diameter orifice in the cavity. Without a double clipper switch, the oscillation cavity is 580 mm long, the output pulse energy is about 70 mJ, the pulse width (FWHM) is 10 ns. With a double clipper switch, a wider pulse is required of the oscillation stage and the cavity length is changed to 1100 mm, and the measured pulse width (full width at the base) is 40 ns.

2. Amplifier series

All the laser amplifiers are constructed using Chinese-made silicate III neodymium glass. The total length of the Nd:glass rods is 520 mm. There are three different rod diameters: $A_1 \sim A_3$ are 20 mm, A_4 and A_5 are 35 mm, and A_6 and A_7

are 45mm. All the end faces of the rods are polished at an angle to suppress self-oscillation.

The first three stages each has two pumping lamps and the other stages have four pumping lamps. The lamps are placed symmetrically. If the lamps in the front stage are arranged in the up and down and left and right pattern, then the lamps in the back stage are arranged in a criss-crossed pattern. This lamp layout helps to improve the lateral homogeneity of the entire beam.

Two-way films (one half antireflecting and the other half total reflection) are placed before and after amplifier A_1 to make A_1 a triple transit amplifier, as shown in Fig. 2. The purpose of this arrangement is to increase the laser energy of the input wave clipper switch to compensate for the large loss of the wave clipper switch. In this arrangement amplifier A_1 may make good use of its stored energy because the signal from the oscillator is not too strong, one transit through A_1 will only deplete a small portion of the population inversion and triple transit through A_1 will provide sufficient amplification. However, triple transit can easily lead to self-oscillation and the tuning must be done carefully.

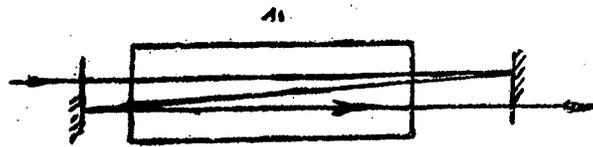

Fig. 2. The triple transit amplifier

3. Pulse clipping gate

The pulse clipping gate consists of two Pockels' cells, as shown in Fig. 3, and acts as a clipper for Q-switched devices and as a single pulse gate for non Q-switched devices.

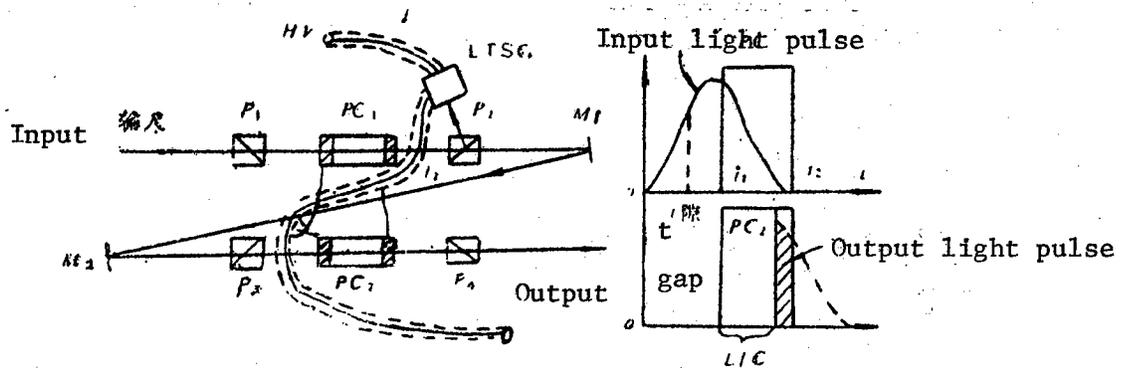

Fig. 3. Dual Pockels' cell electro-optic switch

The distance between mirrors M_1 and M_2 may be adjusted to match the switching time and the output pulse width. If the zero of time is chosen at the instance that the laser light reaches the analyzer P_2 , then t_{gap} is the time duration from the trigger of the spark gap to total conduction, t_1 is the time when the electric field is applied to the KD*P crystal, t_2 is the time when the electric field is removed, and τ_{input} is the pulse width of the input pulse. The time for the light to travel from P_2 through M_1M_2 to PC_2 is the optical path length L divided by the speed of light C . The pulse width from the clipper switch is therefore

$$\tau_{output} = t_2 - t_1 - L/C = 2l_1/v - L/C = (3l_1 - L) / C$$

where l_1 is the length of the shaping cable and v is the propagation speed of the signal in the cable (equal to $2/3 C$). Evidently, changing either l_1 or L will change τ_{output} .

4. Optical isolators

The electro-optic switch described above also plays the role of a temporal isolator. In addition, the system also has the conventional Farady magneto-optic isolator⁹ and Frisnel isolator¹⁰. The latter two are directional isolators which allow the positive-going light to pass and not the negative-going light.

The isolators greatly enhance the ability of the system to suppress self-oscillation. This is done, of course, at the expense of some loss. It is discovered experimentally that if the double clipper switch is removed from the system and only keep the Farady isolator and the Frisnel isolator, then, when the focusing lens in the target chamber is coupled to the light path, it may form a resonance cavity with the output mirror of the oscillator and strong self-oscillations may develop at a certain gain. Such energy pulses can destroy the target material but cannot effectively produce X-ray. In our experiments with 10 ns pulses, the self-oscillations may be effectively suppressed by installing a small aperture in front of the oscillator output mirror.

5. Spatial filters

Strong laser lights above the critical value may cause an increasement in the nonlinear refractive index of the medium:

$$\Delta n = n_2 E^2,$$

where E^2 is the light field intensity and n_2 is the non-linear refractive index. Nonuniform distribution of Δn and the total internal reflection due to the discontinuity in the refractive index at the boundary separating the illuminated area and the unilluminated area cause self-focus of the light beam¹¹. Self-focusing prevents the laser power from going up and degrades the homogeneity of the light beam, and, in extreme cases, may cause damage of the medium.

Spatial filtering helps to improve the beam homogeneity and thereby prevents self-focusing. Figure 4 shows schematically the spatial filter. In our system there are two spatial filters separated by an orifice of different diameter in the 0.5 mm to 2 mm range. The orifice diameter is selected for a described cutoff frequency K_c . The cutoff frequency K_c is equal to $K_c(d/2f_1)$, where K_c is the laser wavenumber, and d is the orifice diameter. Generally K_c is from 15 to 30 cm^{-1} . Since the two lenses have different focal lengths, the spatial filters may also be used as a beam spreader.

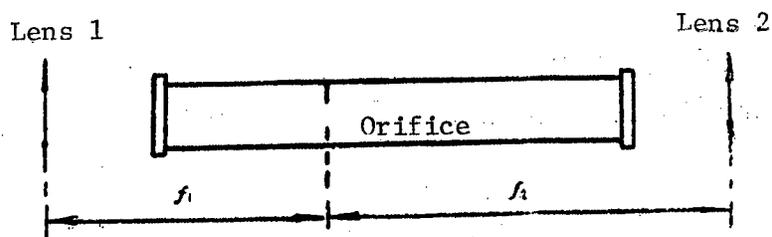

Fig. 4. Spatial filter

6. Target device

We modified a vacuum film evaporator into our vacuum target chamber. The target material is placed on an adjustable frame and the mounts of the focusing lens and the crystal spectrometer are also adjustable. The X-ray spectrum is photographed according to the well known Bragg diffraction, but some details must be attended to in order to obtain sharp X-ray pictures.

The reflecting mirrors, the He-Ne tube, the parallel light pipes and the lenses in front of the target chamber help to align the focusing lens and the target. By measuring the wavefront of the laser and thereby adjusting the focusing, the 1.06 μ m laser light may be accurately focused on the target surface which greatly enhances the conversion efficiency of the laser plasma X-ray.

III. The LPX Experiment

The high power laser light (10 J, 10 ns) produced by the apparatus described above first passes through a nonspherical lens with a 60 mm diameter aperture and a 60 mm focal length and then focuses on the surface of a magnesium target in the target chamber at a pressure of 10^{-2} torr. The spectrum of the laser plasma X-ray is then taken. In the experiment the focal spot size is 100 μ m in diameter and the power density at the target surface is therefore about 2×10^{13} W/cm^2 .

The focal point of the nonspherical lens is first found for 6328 Å using the TEM mode He-Ne laser light expanded with a theodolite. The focal point of the 1.06 μ m Nd:glass laser is then obtained using the theoretical equation for the focal length of a lens.

The plasma X-ray produced at the target surface by the focused high power laser is diffracted by the TLAP triple function X-ray crystal spectrometer¹³ (see Fig. 5) and recorded on type 5F medical X-ray films used in Shanghai. The film is first developed in a D-72 developer solution for 5 minutes and then fixed in a F-5 fixer solution for 15 minutes. The film darkness versus X-ray intensity calibration curve of the X-ray film has been determined beforehand.

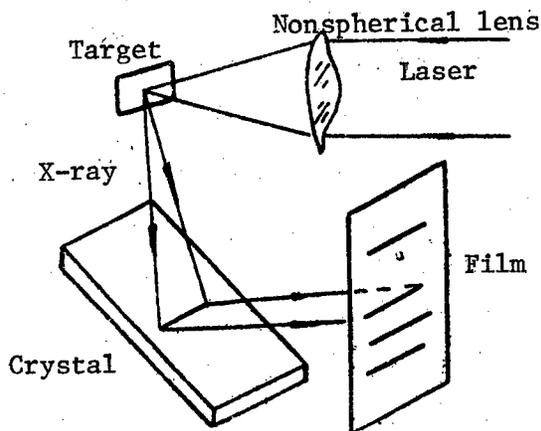

Fig. 5. Schematic diagram of the LPX spectrophotography experiment. The diffraction of an X-ray crystal spectrometer is given by the Bragg formula:

$$2d\sin\theta = n\lambda,$$

where d is the spacing between the crystalline planes, θ is the diffraction angle and λ is the wavelength of the diffracted X-ray. The diffraction order n is generally taken to be 1.

Figure 6 shows the photograph of the LPX spectrum of magnesium and Fig. 7 shows the blackness scanning curves of the photograph. In Fig. 6 the spectral lines and their wavelengths of the higher order ionized hydrogen-like and helium-like ions are indicated. As can be seen, the intensity of the hydrogen-like resonance line $1S^2 - 1S2P^1P$ of magnesium at the 9.168 Å is clearly stronger than that of the helium-like resonance line $1S - 2P$ at $\lambda = 8.422$ Å. (The blackness at the peak is greater than 1.5). Relatively speaking, the electronic temperature of the laser plasma is quite low, and, judging from the intensity of the satellite line, the $1S2P - 2P^2$ satellite (at $\lambda = 8.55$ Å) of $1S - 2P$ is far stronger than the $1S^22P - 1S2P3P$ satellite (at $\lambda = 8.071$ Å) of $1S^2 - 1S3P$. Finally, the intensity of this satellite is almost comparable to that of the main line $1S^2 - 1S3P$.

Notice that in the LPX spectrum the intensity of the recombination radiation¹⁴ is directly proportional to $\exp(-h\nu/kTe)$. Using the recombination radiation in the spectrum with a wavelength shorter than that of the $L\beta$ line of hydrogen-like magnesium ion, the electronic temperature T_e of the plasma is found to be approximately 150 eV or almost 1.7 million degrees.

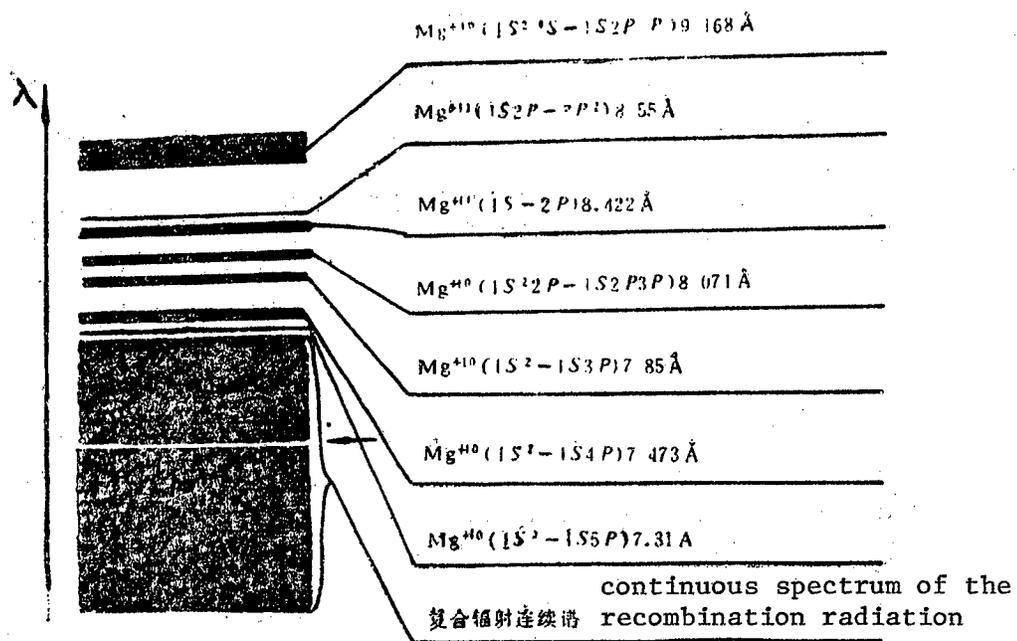

Fig. 6. Integrated X-ray spectrum of higher order magnesium ions

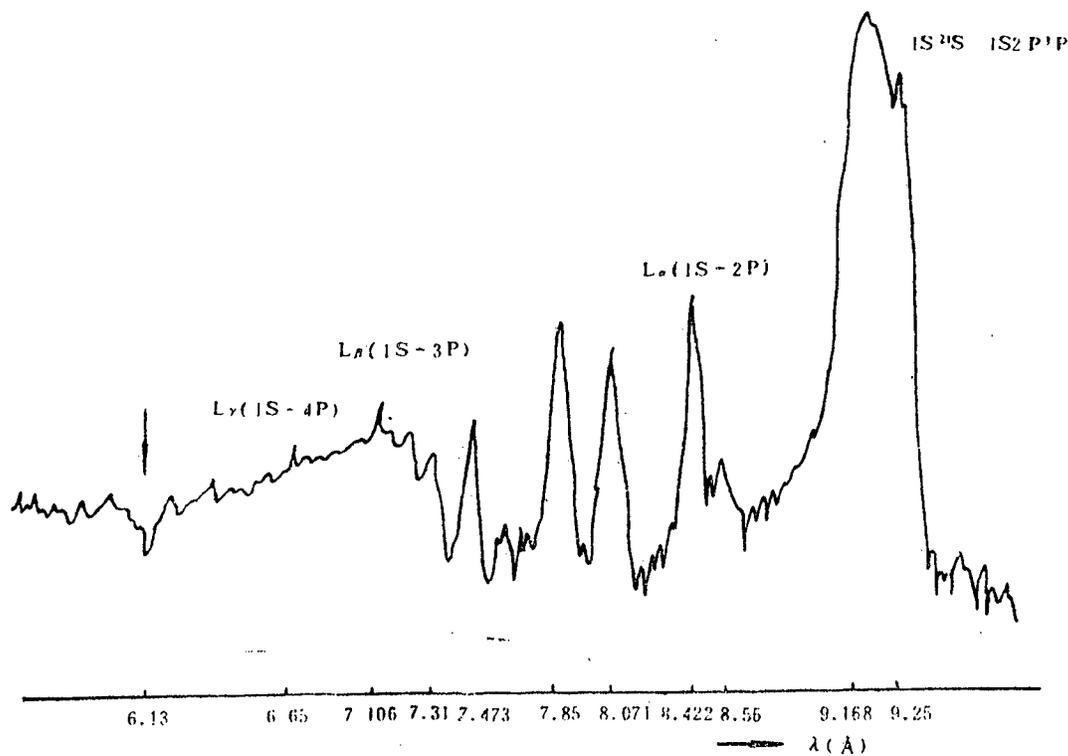

Fig. 7. Blackness scanning curve corresponding to the spectrum in Fig. 6

The existence of the emission spectra of hydrogen-like and helium-like magnesium and the fact that the electronic temperature is over 1 million degrees are sufficient evidences that our high power laser and target system is capable of laser plasma and related experiments. The electric field intensity at the laser focal spot is comparable to the electric field strength at the K shell of a magnesium atom so that the magnesium atom is quickly stripped to the K shell.

Interestingly, an absorption line (indicated by an arrow in Fig. 7) at a wavelength of 6.13 Å is observed in the recombination spectrum of magnesium. This absorption line is caused by the cold absorption of the hot LPX spectrum of magnesium when it passes through some other element.

We have also photographed the LPX spectra of the K series radiation of ionized Na and the L series radiation of ionized Cu.

The authors thank their colleagues for assistance and interest in the construction of the laser system. The Shanghai Institute of Optics and Fine Mechanics provided broad and effective support and the enthusiastic assistance of Chen Shisheng [7115 2514 5168], Lu Renxiang [4151 0088 4382], Sun Naigeng [1827 0035 1649], Xu Zhenhua [1776 2182 5478], Wang Zhian [3769 3112 1344], and Li Anmin [2621 1344 3046] of the Shanghai Institute and the help provided by the Anhui Institute of Optics and Fine Mechanics, the Huihai Machinery Works and the experimental plant of the China University of Science Technology are all gratefully acknowledged.

References

1. Charatis, G., et al., Plasma Physics and Controlled Nuclear Fusion Research, 5th Conf. Proc., Tokyo, 11-15 Nov., 2 (1974), 317.
2. Basov, N. G., et al., Laser Research, 4 (1977), No 2, 187.
3. Ahlstrom, H. G., et al., Laser Research, 4 (1977), No 4, 1.
4. Xu Zhizhan [1776 5267 1455], Li Anmin, Chen Shisheng, et al., WULI XUEBAO [Acta Physica Sinica], 29(1980), No 4, p 439.
5. Deng Ximing [6772 6932 6900], Yu Wenyan [0151 2429 3508], et al., GUANGXUE XUEBAO [Acta Optica Sinica], 1(1981), No 4, p 289.
6. Willson, J., Laser Focus, 17(1981), No 7, 47.
7. Guo Dahao, ZHONGGUO KEXUE JISHU DAXUE XUEBAO [Journal of China University of Science and Technology], 14(1984), No 2, p 286.
8. Lin Lihuang [2651 4409 3552] and Chen Shisheng, JIGUANG [Lasers], 6(1979), No 1, p 4.
9. Lin Lihuang, et al., JIGUANG, 6(1976), No 12, p 36.
10. Lin Lihuang and Chen Shisheng, JIGUANG, 6(1979), No 11, p 33.

11. Ghatak, A., Optics, 1977, 338.
12. Ghatak, A., Optics, 1977, 343.
13. Lu Renxiang, et al., GUANGXUE XUEBAO, 2(1982), No 6, p 568.
14. De Michelis, C., et al., Nuclear Fusion, 21(1981), No 6, 677.

9698

CSO: 4008/338

APPLIED SCIENCES

TITANIUM EXTRACTANT T105-1 STUDIED

Shanghai HUAXUE SHIJIE [CHEMICAL WORLD] in Chinese Vol 26, No 3, 20 Mar 85
pp 82-83

[Article by Mu Guangzhao [4476 0342 3464]]

[Text] Titanium is a special product of our country with abundant reserve that is largest in the world. It is distributed among many provinces and prefectures. The most abundant resource is panzhihua, which exists in a huge ilmenite deposit rarely seen in the world. Metallic titanium and titanium alloy have excellent properties that lead to wide applications. In the application areas of spaceflight, aviation, navigation, chemical industry, metallurgy, and shipbuilding, they are found to be better structural and corrosion-resisting materials and have accelerated the adoption of new technologies with notable beneficial results. Therefore, it is referred to as "developing third metal" besides iron and aluminum and has vast future for development.

Titanium white (titanium dioxide), a major titanium compound, is widely used in metallurgy, enamel, paint, ink, welding rod, condenser, plastics, rubber, papermaking and synthetic fiber. It is being produced domestically by 40 plants with annual production of over 20,000 tons. The supply falls short of demand and top grade titanium white has to be imported from abroad. Domestic production method generally starts with ilmenite (including panzhihua and liangguanguang) as raw material, which is turned into product by the working procedures of dissolving with concentrated sulfuric acid, followed by purification, hydrolysis, washing, aftertreatment, calcination and crushing. It is a long technological process with high energy consumption and high impurities in the final product. It also produced more "three industrial wastes" (including waste sulfuric acid). The technology is urgently in need of improvement. Consequently, a research agreement was signed between the Eastern China Chemical Engineering College and the Shanghai Titanium White Plant to study the new technology of solvent extraction in order to extract, by using extractant, the Shanghai Titanium White Plant's titanium-sulfuric acid solution. Extractants were supplied by the Eastern China Chemical Engineering College and the extraction studies were done at the Shanghai Titanium White Plant. Since September, 1983, the Eastern China Chemical Engineering College has provided two titanium extractants, T105 and T105-1. T105-1 is a highly-efficient titanium extractant that is able to extract in

strongly acidic media. A molar solution of this extractant in carbon tetrachloride was used to extract the Shanghai Titanium White Plant's titanium-sulfuric acid solution (prepared by concentrated sulfuric acid treatment of ilmenite, followed by refrigeration separation to remove the majority of ferrous sulfate). A small-scale shake-glass experiment was carried out on an adjustable-rate, multiple-use shaker. Under optimal condition, the primary extraction rate reaches as high as 97.2 percent. It shows high selectivity, high reproducibility and good water immiscibility. It is a better titanium extractant. The solution was provided by the Shanghai Titanium White Plant and analysis were carried out according to the current quantitative standards of the Shanghai Titanium White Plant.

In this paper, the phase ratio O/A (organic phase/aqueous phase) and the influence of extraction time on extraction rate in the extractions by T105-1 of titanium-sulfuric acid solutions of various concentration were studied. Extractions were done at room temperature.

I. Factors That Influence Extraction Rate

1. The Effect of Solution Concentration

It is obvious from tables 1 and 2 that within the range of 1 to 3 fold dilution of the solution, the extraction rate increases with increasing dilution. However, when considering the reality of plant production, it is undesirable to dilute too much because then there will be more waste acid.

Table 1.

Sample No.	Solution Concentration	Before Ex- traction(g/l)	After Ex- traction(g/l)	Extraction Rate (%)
A-1	Titanium-Sulfuric Acid	157	119.08	24.15
B-7	1 Fold Dilution	81.98	55.64	31.68
C-13	2 Fold Dilution	55.12	32.7	40.57
D-19	3 Fold Dilution	40.56	15.18	62.57

Table 2.

Sample No.	Solution Concentration	Before Ex- traction(g/l)	After Ex- traction(g/l)	Extraction Rate (%)
A-2	Titanium-Sulfuric Acid	157	118.58	24.48
B-8	1 Fold Dilution	81.98	50.96	37.88
C-14	2 Fold Dilution	55.12	28.80	47.75
D-20	3 Fold Dilution	40.56	13.31	67.18

2. The Effect of Phase Ratio

From table 3, it can be concluded that with more concentrated solutions, increase of phase ratio improves the extraction rate. But beyond three fold dilution, the change in phase ratio has little effect on extraction rate.

3. The Effect of Extraction Time

Table 3.

Sample No.	Solution Concentration	Phase Ratio (O/A)	Before Ex-	After Ex-	Extraction Rate (%)
			traction (g/l)	traction (g/l)	
A-1	Titanium-Sulfuric Acid	1:1	157	119.08	24.18
A-4	Titanium-Sulfuric Acid	2:1	157	110.24	29.78
B-7	1 Fold Dilution	1:1	81.38	55.64	31.63
B-10		2:1	81.38	52.52	35.46
C-13	2 Fold Dilution	1:1	55.12	32.70	40.57
C-16		2:1	54.86	24.96	54.50
D-19	3 Fold Dilution	1:1	40.56	15.18	62.57
D-22		2:1	38.10	14.35	62.34

Under fixed phase ratio of 2:1 and at room temperature, the effect of extraction time on the extraction rate of various solutions was shown in table 4.

Table 4.

Sample No.	Solution	Time	Before Ex-	After Ex-	Extraction Rate (%)
			traction (g/l)	traction (g/l)	
B-10	1 Fold Dilution	10	81.38	52.52	35.46
B-11		30	81.38	37.75	53.61
B-12		60	85.90	2.40	97.20
C-16	2 Fold Dilution	10	54.86	24.96	54.50
C-17		30	54.86	16.22	70.43
C-18		60	54.86	3.02	94.50
D-22	3 Fold Dilution	10	38.10	14.35	62.34
D-23		30	38.10	9.57	74.38
D-24		60	38.10	2.91	92.36

From table above, it can be seen that there is a marked increase in extraction rate with increasing extraction time. There is a linear increase of extraction rate with extraction time up to 60 minutes. The primary extraction rate of B-12 reaches 97.2 percent. In actual production, increasing extraction time will inevitably lengthen the production cycle. Therefore, adequate compromise among the three sides of solution concentration, extraction time and extraction rate is necessary.

II. Summary

1. In our country, there is no precedent in extraction by titanium extractant of titanium-sulfuric acid solution of titanium white plants.
2. Using titanium extractant T105-1 to extract the Shanghai Titanium White Plant's titanium-sulfuric acid solution, the primary extraction rate reaches 97.2 percent under optimal condition.

3. T105-1 has good selectivity and is a better titanium extractant.
4. The extraction of titanium-sulfuric acid solution is an attempt in reforming the sulfuric acid method of producing titanium white.
5. On June 19, 1984, titanium extractant T105-1 passed technical evaluation in Shanghai on small-scale titanium extraction capability.
6. From now on, cooperation between plant and school will continue to be strengthened, back extraction studies will be carried out and the production of rutile type of titanium white for paint will be attempted.

12922

CSO: 4008/1012

APPLIED SCIENCES

PRC, BRITISH SCIENTISTS TO EXPLORE TIBETAN PLATEAU

OW242012 Beijing XINHUA in English 1918 GMT 24 May 85

[Text] London, 24 May (XINHUA)--Scientists from Britain and China will soon start the first joint geotraverse of the Tibetan plateau for further understanding of the mechanisms and chronology of the development of the Asian and Indian tectonic plates, Professor R.M. Shackleton of the Royal Society told XINHUA today.

The joint project, organized by the Royal Society and the Chinese Academy of Sciences, will pull together 12 British and 14 Chinese scientists to further study how the Indian plate, which moved northward, and the Asian plate moved toward one another, Shackleton said.

The British group, led by Professor Shackleton, will leave London for Beijing on 26 May and the actual survey starts at the beginning of June.

The geotraverse will start in Lhasa (altitude 3700 m) and proceed northward 1200 km to Golmud (altitude 2800 m), attaining a maximum altitude of 5100 m in the Tanggula mountains, and is due to be completed by the end of July or early August.

Following the completion of the geotraverse, Professor Shackleton said, four of the Chinese geologists will come and work with their British colleagues in U.K. laboratories up to a total of 24 man-months, and probably similar arrangements will be made for members of the British team to work in China.

The results of their joint geotraverse, Shackleton said, will be published in London as well as in Beijing.

The Royal Society sees the project as a scientifically exciting joint undertaking and as further evidence of the successful relations between the society and the Chinese Academy of Sciences.

CSO: 4010/154

APPLIED SCIENCES

PRC DESCRIBED AS WORLD LEADER IN GEOPHYSICAL SURVEYS

OW301011 Beijing XINHUA in English 0629 GMT 30 May 85

[Text] Beijing, 30 May (XINHUA)--China has launched aerial geophysical surveys covering 9 million sq km over the past 30 years, more than any other country.

Survey lines exceed 9 million km, said Zhuo Songnian, leader of the Aerial Geophysical Survey Team under the Ministry of Geology and Minerals Resources, at a conference now in session here.

China began applying aerial geophysical survey techniques in 1953, Zhuo said. Equipped with special planes and modern instruments, his team has located over 300 mineral deposits across China.

Eighty percent of the magnetite deposits discovered after 1949 were the results of aerial geophysical surveys, he told the conference.

The team has also verified 2,000 possible oil and gas structures, helping find major oil fields such as Daqing and Dagang. Data has also been provided for assessment of oil and gas reserves in the Bohai, East China and Yellow Seas, the Pearl River estuary and the Qaidam and Tarim basins.

In addition, Zhuo said, his team has provided data for drawing up overall construction plans for Beijing and Lianyungang in Jiangsu Province.

An aeromagnetic survey map on the scale of 1:1,000,000 has been worked up for eastern China.

CSO: 4010/154

LIFE SCIENCES

NEW LAW ON PHARMACEUTICAL MANAGEMENT EFFECTIVE 1 JULY

HK140418 Beijing CHINA DAILY in English 14 Jun 85 p 1

[Article by staff reporter Chen Guangeng]

[Text] China's first law on pharmaceutical management comes in to effect on 1 July as the mainstay of a new national campaign to tighten control over the country's medicine manufacturing and distribution.

The law is one of the most important steps being taken to guarantee that all medicines are beneficial and that none pose hazards to health.

Under the law, approved by the Standing Committee of the National People's Congress last September, the state will enforce a series of new measures to improve the country's pharmaceutical management. These include establishing a national inspection system for sale and import of medicine, tightening control over management of narcotics and toxic drugs, prohibiting fakes or outdated medicine, and introducing national standards for medicine packaging.

Medicine manufacturers and dealers must apply for licenses before they begin business, and hospitals will be barred from selling their preparations on the open market.

Before going into production, all new medicines will have to be examined and approved directly by the Ministry of Public Health.

The ministry is to set up this week a 51 member committee to take charge of the work.

New medicines will also have to undergo clinical tests at one of 14 test centers set up across the country.

"The promulgation of the law on pharmaceutical management has stated a new era when we can bring our medicine supervision and management onto a legal track," Vice Public Health Minister Hu Ximing said yesterday.

"The safety and effectiveness of medicine affects millions of people, so our efforts in this respect should be further intensified," he said at the opening of a national conference on pharmaceutical management.

He urged all medical departments to abide by the law, warning that punishment will be meted out to violators.

Despite state restrictions and regulations, cases have been frequently reported in the country of malpractice in medicine manufacturing and dealing.

These have included selling fake medicines, peddling outdated or substandard medicine, driving up the prices of medicines in times of short supply and even using bribery.

According to a report by the Shanghai Auditing Office, nearly 100 units from the other parts of the country came to peddle popular medicine in the municipality from last October to March this year.

Some pharmaceutical plants began to bribe the purchasing officials to win bigger and more orders. In just 6 months a pharmaceutical plant in Jiangsu Province spent 310,000 yuan in the promotion of one of its substandard products.

CSO: 4010/2003

LIFE SCIENCES

BRIEFS

SHANGHAI CANCER RESEARCH--Shanghai, 25 May (XINHUA)--Scientists at the Shanghai Material Medical Institute have produced a new anti-cancer drug, said the local branch of the Academy of Sciences here today. The laboratory results have been academically assessed, and the drug, Aclacinomycin A, is undergoing pilot tests. A group of five headed by Antibiotics Laboratory Deputy Head Zhang Hailan began the research last March. Zhang said the drug was very promising, having only one-tenth the toxicity of the conventional anti-cancer drug Adriamycin. It was effective against cancers of the stomach, lung, breast, ovary and blood, he said. [Text] [Beijing XINHUA in English 1123 GMT 23 May 85]

NEW DRUG MANAGEMENT LAW--Beijing, 12 Jun (XINHUA)--China's new pharmaceutical management law will come into effect next month to protect people from ineffective or dangerous medicines, a Public Health Ministry official said today. A pharmaceutical examination and appraisal committee has been set up to implement the law. The National People's Congress Standing Committee, which approved the law last September, has decided to implement it next month. Under the legislation, the ministry will take sole charge of the production, management and sale of pharmaceuticals, and will also have the right to prosecute law-breakers. The committee, which is made up of 51 medical specialists, will examine all the new pharmaceuticals, and reappraise those already on sale, said the official. All new pharmaceuticals will have to be fully examined before they can be marketed. [Text] [Beijing XINHUA in English 0741 GMT 12 Jun 85]

MENINGITIS CAUSE DISCOVERED--The department of dermatology of the Changhai Hospital of the Second Military Medical University recently discovered a Changhai variety of cryptococcus neoforms, which is a new pathological bacteria that can cause meningitis and other diseases. Cryptococcus neoformans is a type of fungus; it can enter the skin, lungs, lymph nodes and other visceral organs of humans. It commonly enters the central nervous system, and causes torular meningitis. Medical personnel of the fungus laboratory of the department of dermatology at Changhai Hospital in September, 1983 isolated this type of cryptococcus neoformans from a meningitis patient; it has more than 50 forms. Through observation and research, concerned experts believe this is a new type of pathological bacteria. [Text] [Changcun JILIN RIBAO in Chinese 9 Apr 85 p 1]

ENVIRONMENTAL QUALITY

ROLE OF ENVIRONMENTAL MONITORING IN ENVIRONMENTAL ADMINISTRATION

Beijing HUANJING BAOHU [ENVIRONMENTAL PROTECTION] in Chinese No 3, Mar 85 pp 2-3, 7

[Article by Sun Jiajin [1327 0857 6930]: "The Role of Monitoring in Environmental Administration"]

[Text] Environmental monitoring is the determination of the quality of an environment by physical, chemical and biological means and its description, with accuracy of characterizations and quantitative measurements. It is an important means to know about the environment and to make an evaluation of the environmental conditions. It is an important basis for the transformation of the environment and for environmental constructions, and it is also the foundation for the formulation and implementation of environmental laws and standards. It is the foundation for the enforcement of environmental management and of all relevant decisions, as it is also the important foothold on which to base an effective protection of the environment. Environmental monitoring, therefore, occupies a very important position in the entire environmental protection work and must be afforded a high degree of attention.

(1) Since the First National Environmental Monitoring Work Conference held in December 1980 until October 1984, 1,140 monitoring stations have been set up within our nationwide system of environmental protection. Great improvements have been achieved in the work quality and capability for comprehensive analytical work by our monitoring personnel; many capable scientific and technological personnel with good managerial skills have assumed leading posts.

(2) Construction of the 64 environmental monitoring stations, assembled as key projects during the Sixth 5-Year Plan period, has been basically completed. Automatic monitoring systems for waste water are actually in operation. Fourteen sets of computer-controlled automatic systems for atmospheric monitoring have been appraised, found acceptable and have been started up. An automatic monitoring system for noise control and surface water quality is being speedily set up. Preliminary work on the construction of networks for the monitoring of the atmosphere, water quality, acid rain, radioactivity and noise has been completed, and biological monitoring work has also been started. Marked progress has been made in monitoring and analyzing techniques, and neutron activation, high frequency inductive coupling and ion spectral emissions are techniques now being used in environmental analyzing. Chromatography of liquids, on-line mass spectroscopy-chromatography and

computer processing is being used in the analysis and determination of complex organic materials, and environmental monitoring employs cars for monitoring atmospheric pollution, boats for monitoring water quality and airplanes for surveys of the ocean environment. One may say that our system basically has a comprehensive capability for high-quality monitoring of water quality, of the atmosphere, of soil, sediment, organic matter and of agricultural chemicals.

(3) In the last few years, awareness of the importance of environmental monitoring has been greatly raised among all entities concerned with environmental management, scientific research and planning and with environmental evaluations, also among the relevant departments in industrial enterprises. Increasing importance is being attached to the role of environmental monitoring in the field of environmental management, enterprise management and management of engineering projects. However, a considerable number of our comrades still underestimate the role of monitoring in management and give it insufficient attention. If environmental monitoring work is regarded purely as the work of testing and analyzing performed in laboratories, then monitoring consists in obtaining accurate data on certain items of environmental elements, but no attention will then be given to a whole series of tasks, such as planning programs for points of deployment and collecting samples; there will be no follow-up on laboratory analyses and testing by further data processing and more comprehensive analyses, which might enable statements on the changing trends in environmental quality and reports on environmental quality, and there will be no decisions taken or suggestions submitted for the benefit of environmental management and for the benefit of entities concerned. If, on the other hand, environmental monitoring work is merely regarded as obtaining data on discharged pollutants, to collect waste discharge fees, one would disregard that its purpose is to implement the state's environmental protection laws, regulations and the standards for the discharge of pollutants, also to exercise supervision over the discharge of pollutants, to control the sources of pollution, to control new pollutants from being created, and to provide data for policy decisions on a series of tasks such as promoting better enterprise management, raising the utilization ratio for resources and energy, preventing new sources of pollution, etc. There is yet another misunderstanding, namely that the construction task of a monitoring station may be considered done as long as the building has been constructed, equipment and instruments are in one's hands and tests have produced the required data. This would disregard that the frequency of our monitoring is low, that our data are not very representative, that their accuracy is not high, that we cannot yet conscientiously institute periodic monitoring of pollution, that we cannot yet effectively, promptly and accurately report on environmental conditions and their changing trends. The results of an evaluation of our monitoring, carried out in 1983, makes this problem very clear: participating in the evaluation were 54 laboratories from the 64 stations, which the state was planning to set up, and a number of technically highly qualified comrades. A total of 201 evaluations were carried out, and only 149 cases were found up to standards, while 25.9 percent did not qualify. In the 54 laboratories, only 34.9 percent qualified regarding four items of water quality analyses. This shows how urgently we need to raise the quality of our environmental monitoring.

(4) To bring the role of monitoring more effectively into play in our environmental management, we must further clarify the fundamental tasks of environmental monitoring. According to the provisions of the "National Regulations Governing the Management of Environmental Monitoring," and in view of the actual practice in all parts of the country, the task of environmental monitoring stations at all levels can be summarized in the following three aspects:

First, they are to institute monitoring of the environmental quality, systematic control of the environment and are to provide information on the quality of the environment. Currently, the environmental monitoring stations throughout the country have already set up regular monitoring systems for such environmental factors as the atmosphere, bodies of water (surface water, underground water and oceans) and noise. These areas of work are the main content of the almost 5 million data assembled every year throughout the country. Effective monitoring of the environmental quality is of extremely important significance for the determination of general and specific policies of environmental protection in the state, in the various localities and in drainage areas, for the deployment of our productive forces, for plans of regional economic and social developments, for the control of the total discharge of pollutants into the environment, for the determination of tasks of checking sources of pollution, for the mobilization of the masses to protect the environment, thus the basic conditions for human existence. Mastery of the skill of evaluating environmental conditions is the indispensable precondition and basis for the study of the laws that govern the shifts and transformations of pollutants in the environment, for the study of the impact of concentrations of pollutants on human health and on the ecological balance and for the determination of norms for environmental quality.

Monitoring of environmental quality comprises mainly the following:

1. The scientific distribution of environmental monitoring stations and networks in all localities, cities, drainage and ocean areas, so that the resulting data will be representative of the environmental quality of the areas in question.
2. The continuous or periodical collection of samples, monitoring and providing accurate data on environmental quality of all environmental factors according to a uniform set of methods and standards.
3. Processing of monitoring data, collecting and storing them and compiling environmental monitoring yearbooks according to a set of uniform rules.
4. In an integration of monitoring data for all sources of pollution, carrying out comprehensive analyses of all environmental monitoring data, produce statements or forecasts of trends of changes in the environmental quality, nationwide or for certain regions, cities, drainage and ocean areas and special environmental regions (such as nature preserves, scenic tourist areas), submitting suggestions for the improvement of environmental quality and the prevention of pollution, compiling monthly or annual reports on environmental monitoring for the benefit of the management of the environment and of China's four modernizations.

Second, institute monitoring regarding pollution control. Implementing the environmental laws and regulations and improving environmental quality is, fundamentally speaking, giving attention to the degree of control over the sources of pollution. Environmental control, its planning and guidance, organizing cooperation is the main content of environmental management. The self-determination of enterprises in their business operations heightens the importance of environmental law, of supervision and of checking. Control of the sources of pollution, whether it is by administrative, legal, economic, engineering technical or by propagandistic and educational means, is inseparably linked with the monitoring of the sources of pollution. This is equally the case when setting a time limit for the stoppage of pollution sources, when strengthening the administration of pollution sources, when imposing fees for discharge of waste materials, when handling pollution accidents and when inquiring into the administrative or legal responsibility for pollution accidents. Study of the regional capacities for environmental self-purification as well as the overall control of the total quantity of pollutants also relies on absolute knowledge of the pollution, and, furthermore, requires monitoring and supervising to be effective. Monitoring work serves the supervision and management of the environment and is mainly effected by investigating and monitoring the sources of pollution.

Monitoring for the sake of environmental control comprises the following activities:

1. Extensive investigations of the sources of pollution within the area in question, to gain thorough and complete knowledge of the distribution of the sources of pollution, their nature, size, types and quantities involved and all other related environmental conditions, it also entails setting up files on sources of pollution. 2. On-the-spot monitoring of sources of pollution or checking test data from entities that are sources of pollution, if necessary by means of spot checks, to serve a variety of purposes:

--check implementation of the provisions of the environmental protection law and the standards of polluting emissions, by means of survey-type monitoring, to provide a basis that will bring the sources of pollution under control within a set time limit;

--levying charges for polluting emission or for polluting emissions in excess of standards;

--strengthening control and management of sources of pollution and evaluating environmental norms, to provide a basis, on engineering and technological grounds, for the technological restructuring of enterprises;

--computing total quantities of pollutants and effecting control over the total quantity of pollutants in a certain region or city.

3. Checking the acceptability and monitoring equipment for pollution control in new constructions, expansions, remodeling or technological restructuring projects.

4. Monitoring pollution accidents to clarify the reasons for the accident, establish the scope of damage and provide basic data for an investigation of the administrative, economic and legal responsibility.

5. Monitoring to help resolve pollution disputes by providing the data on which to base decisions on the arguments of the polluting entities or the injured entities or individuals.

Third, launching monitoring as research in environmental science and as service to society. In a broad sense, environmental monitoring is surveillance and measuring the environmental quality on which mankind relies for its existence, determining in the environment the changes in harmful chemicals on earth, and thereby adding to our knowledge of the impact of environmental quality changes on economic developments and on all living creatures, and, furthermore, devising strategies, policies, ways, plans and methods for the improvement of the environment. All this work is by nature scientific research.

The scientific research and service aspects of monitoring mainly comprise the following:

1. Monitoring mainly for the purpose of scientific research. Launching research into environmental quality that comprises evaluation of the environmental quality, into the laws of changes in the environmental quality, into the capacity of the environment for natural dilution, dispersal and purification; monitoring and research of acid rain; monitoring and general survey of the content of organic chlorine agricultural chemicals and other toxic chemicals in grain, vegetables and meat; investigation of the atmosphere, bodies of water, soil and organisms as to background content of heavy metals and other pollutants; investigation of radioactive background; all these tasks fall into the category of this work.

2. Instituting monitoring research to raise the quality of monitoring technology, as, for instance, to unify the analytical methods employed in monitoring, determining norms for monitoring technology, developing monitoring instruments, equipment and standard materials, and the determination of trace inorganic and organic materials in the environment, etc.

3. Monitoring as service to society, for instance, using monitoring data, instruments, equipment and well qualified specialized scientific and technical personnel to full advantage in undertaking monitoring tasks entrusted by various entities of society, providing data for environmental impact assessments, making oneself available for technical consultations in matters of monitoring, participate in discussions of research and the planning of comprehensive pollution prevention technologies, etc. The effective performance of these tasks will help inspire enthusiasm among our monitoring stations and among the large number of scientific and technical personnel, to render service to society and to make many further contributions.

(5) The above-mentioned three aspects of monitoring work are organically linked to one another. The mere monitoring of the environmental quality without monitoring data on the sources of pollution, would make it impossible to work out an accurate evaluation of the environmental quality. Among the three aspects of monitoring, the first and second are the major ones and the fundamental ones. Monitoring for scientific research and as service to society is actually work that serves the former two aspects; it is an

expansion and extension of environmental monitoring. Monitoring work as a service to society may only be engaged in after completion of the monitoring tasks of the first and second aspect, if surplus resources are available; it would otherwise mean that fundamental work would be neglected, deviating from the proper course. If monitoring work as service to society is done effectively, while work regarding the first and second aspects are not well done, a monitoring station of this type could not possibly be said to accomplish its tasks.

During a certain period of time in the past, most of our monitoring stations did launch monitoring of the environmental quality. This is extremely necessary work and has had good results. We must continue this work and raise it to a higher level of perfection. We must, furthermore, systematize monitoring of the environmental quality. For a variety of reasons, we have paid insufficient attention to monitoring work regarding control of sources of pollution, so that supervision and management of the environment lacked the necessary monitoring data, which, in turn, resulted in certain difficulties for the enforcement of the environmental laws and standards and the collection of pollution charges. In the future the continuous improvement of our environmental laws and the reform of our economic system, the expansion of self-determination in management and business operations of the enterprises, will certainly bring it about that monitoring work concerned with the surveillance of the sources of pollution will become more complex and more onerous. Conscientious performance by the monitoring stations of all these monitoring tasks will certainly make a contribution toward a change for the better in the condition of China's environmental quality.

9808

CSO: 4008/0316

ENVIRONMENTAL QUALITY

UNDERSTANDING OF ENVIRONMENTAL LAWS, MANAGEMENT OF ENVIRONMENT

Beijing HUANJING BAOHU [ENVIRONMENTAL PROTECTION] in Chinese No 3, Mar 8 pp 11-12

[Article by Luo Dianrong [5012 0368 2837], Chinese University of Politics and Law: "Enhancing Legal Qualities of Our Environmental Protection Personnel and Strengthening Our Management of the Environment"]

[Text] At the Second National Conference on Environmental Protection, the protection of the environment was raised to a fundamental issue of China's national policy, and environmental protection work received serious attention in all quarters. To enhance environmental management, the State Council in May last year decided on establishing a Commission for the Protection of the Environment within the State Council, with the task of studying and deciding on general and specific principles concerning the protection of the environment, of submitting plans and demands, and of providing guidance for environmental protection work and to organize and coordinate such work throughout the country. A short time ago, the State Council, furthermore, passed a resolution to establish a State Environmental Protection Bureau, which is to exercise independently the functions of planning, coordination, supervision and guidance in the various departments throughout the country. At the same time, the ministries and commissions under the State Council and all local authorities at all levels were to strengthen the organizational structure and set up for environmental protection, increase their authorized positions and replenished their staff. This is an important measure taken by the State Council for the strengthening of environmental protection work, which will provide a reliable organizational guarantee for the strengthening of environmental management throughout the country.

Since China's economic is not well developed and China's financial and material resources are limited, China will not be able, for a long time to come, to allot large sums of money for pollution control. On the other hand, environmental pollution and ecological destruction throughout the country are very serious indeed and cause dangers to economic development and for human health that are becoming increasingly serious. To turn this situation around, the method of strengthening environmental management would require little money and would yield quick results, thus be completely geared to the actual conditions in China. Strengthening environmental management, in concrete terms, means strengthening comprehensive management by three means, namely by administrative, economic and legal measures, and among these, strengthening

the application of legal measures is the most important, because the application of administrative and economic measures is inseparably linked with the guarantees provided by legal measures. Only by following the course of the legal system, will administrative acts be sound and effective. Advocating the fullest use of legal measures requires, first of all, great efforts to perfect our legislation for the protection of the environment. Apart from taking the revision of the basic law, namely the "Environmental Protection Law," firmly in hand, and of drawing up certain necessary sectional laws (such as a "Law for the Prevention of Atmospheric Pollution," "Law for Noise Control in Cities," etc.), it is particularly necessary to strengthen local legislative work by the provincial people's assemblies and their standing committees, on the premise that such legislation must not conflict with the constitution and the provisions of state law and administrative law. The reason is that local legislative work is not only more precisely aimed at actual conditions, but can also be accomplished at a much faster pace. It is, furthermore, necessary to exert great efforts in enhancing the legal qualities among workers in the environmental protection field at all levels; they must be made to know the law, understand the law, obey the law and enforce the law. Because the environmental protection law is by nature a kind of administrative law, it provides the environmental protection departments with the foundation for the exercise of their control and supervisory functions. If there are violations by people in their socioeconomic activities, possibly violations of the environmental protection law, the departments with the relevant functions must mainly be relied upon to render guidance or put a stop to such violations. Only in a limited number of environmental cases will the party directly injured by the pollution, file a complaint in court and demand compensation, and in only an extremely small number of cases will it be necessary to investigate criminal responsibility, all being cases that must be handled by the judiciary. The majority of environmental disputes that normally arise are such that must be handled and resolved by the environmental protection departments and other departments concerned. The powers to do so are powers of office conferred on the environmental protection departments and other departments concerned by the environmental protection law, which must be considered an administrative law; it is the main official responsibility of the departments charged with these functions. Working personnel in the environmental protection departments at all levels are, therefore, duty-bound to bear the major official responsibility of implementing the environmental protection law. Most of the personnel working in the environmental protection departments at all levels have many years of experience and good professional knowledge in environmental protection. However, a large number among them are lacking modern managerial experiences, particularly lacking legal knowledge, some even are completely "law-blind." It is, therefore, first of all necessary to train working personnel on active duty in a variety of methods and channels to master a minimum amount of legal knowledge and become familiar with the relevant provisions of environmental protection laws and regulations, so that they can become competent to exercise supervision over departments concerned, enterprises and individuals as to the implementation of the law, and that they will be able to use administrative means to resolve the common environmental disputes which normally come up every day. Second, we must exert great efforts to absorb graduates from law colleges into the environmental protection departments at all levels and have them play the role of a mainstay force in the enhancement of the legal qualities of environmental

protection personnel and in strengthening the legal ways of environmental administration. At the same time, the organizations of environmental protection research at all levels must also launch research in environmental management, particularly launch research into the laws and regulations relevant to environmental protection.

In summary, to cope with the new situation that urgently demands improvement of environmental management work, and in view of the fact that the environmental protection organizations at all levels have already obtained appropriately substantial conditions, the problem of how to raise the quality level of management in the environmental protection departments at all levels and how to enhance the legal qualities of working personnel, how to truly move environmental control to the track of legal institutionalization, all these are tasks of extreme urgency that confront the entire body of environmental protection personnel.

9808

CSO: 4008/0316

ENVIRONMENTAL QUALITY

STATE COUNCIL DETERMINES ENVIRONMENTAL TASKS FOR 1985

Work Plan Outlined

Beijing ZHONGGUO HUANJING BAO in Chinese 13 Apr 85 p 1

[Text] On 6 April, the State Council Environmental Protection Committee issued a notice to request all the provincial, autonomous regions and municipal people's governments and the related departments under the State Council to execute the "Work To Be Done on Environmental Protection in 1985" discussed and passed by the Third Conference of the State Council Environmental Protection Committee held on 26 March.

The notice said that to do real work and to see real results are good tendencies worth encouraging and are important methods to work with. The governments of various levels and all the departments responsible for the work should conscientiously solve some problems which are very harmful, are badly needed by the masses and can be accomplished through effort.

I. Every provincial, autonomous region and municipal government must accomplish the following six tasks:

1. In every municipality and capital city of a province, a soot control area must be established, burning equipment in this area is restricted from emitting black smoke and the discharge of soot must meet the standard. At the same time a model experimental plant using coal must be established.
2. Control one polluted river or a polluted lake, have the pollution basically controlled and make the discharge polluters along the river meet the standards for discharge.
3. In the capital city of a province and in cities with a population above 1 million, the traffic noise in the main streets must meet the national standard.
4. Establish one or two ecological agriculture construction experiment points in a township or village, and, more importantly, establish one test point for pollution control in a small-town enterprise in a country.
5. Do well in construction or scientific investigation in one nature protection area and do well in the protection of several kinds of rare and endangered animals or plants.

6. Complete the construction of monitoring stations in three to five municipalities and in three to five counties.

II. State Council-related departments must do well in the following tasks:

1. Every industrial and transportation department must choose three to five plants among different industries and different types of businesses as models of clean plants, and combine technology and reform to establish two to three plants or workshops as models of would-be major polluters which became clean after being administered.

2. The Ministry of Agriculture, Animal Husbandry and Fishing, with the departments related to environmental protection, should identify some environments for agricultural ecological protection, develop into ecological agriculture test points, use one or two counties to formulate and implement prevention and cure measures for rural industrial pollution.

3. The Ministry of Urban and Rural Construction and Environmental Protection should build new water waste processing facilities that are able to process 320,000 tons per day, construct a new natural gas network and facilities for 2 million households and use two or three cities as test points for garbage treatment and utilization.

4. The environmental protection department of the People's Liberation Army should establish two or three clean plants as models and finish the treatment of major pollution sources such as waste water from printing and dyeing mills and tanneries and the oil-containing waste water from shipyards.

5. Districts and departments related to the organization of the National Environmental Protection Bureau should do a good job on water quality protection on the section of the Luan River leading to Tientsin. They should basically control water pollution in the region from the Da Hei Ting Reservoir to Tientsin, establish a continuous automatic atmosphere-monitoring system for the seven municipalities of Harbin, Dalian, etc., organize and emphasize the construction of molded coal demonstration plants in Shenyang, Chongqing and Taian municipalities and organize and do well in the construction of experimental oxidation ponds for urban and industrial waste water processing in Qiqihar municipality.

Qu Geping Discusses Work Plan

Beijing ZHONGGUO HUANJING BAO in Chinese 13 Apr 85 p 2

[Article by Qu Geping /2575 2706 1627], director of the Office of the State Council Environmental Protection Committee]

[Text] In 1984 we had great results in environmental protection. In that year we made better progress in environmental control and this signified some change in the construction of organizations for environmental protection. In the national environmental protection conference called before the Spring

Festival this year, we summarized the accomplishments in the 10 aspects of environmental protection during 1984. It has been distributed to you, and I am not going to talk about the specifics now.

In the following I want to explain the "Suggested Environmental Tasks for 1985" discussed in that conference.

I. Origin of the Problem

At the Second National Environmental Protection Conference called at the end of 1983, and twice at the conference of the State Council's Environmental Protection Committee, Comrade Li Peng [2621 7720] advocated again and again that leaders in every level should do practical work and expect results in environmental work. Over 20 provinces, autonomous regions and municipalities and more than 70 cities responded to the call, did as he said and brought in very good results. This is a new atmosphere in environmental work.

Li Peng's advocacy of doing practical work and expecting results provided a good deal of enlightenment for us. It made us realize that environmental protection is a big job and is full of difficulties, yet many "longstanding" problems can be solved quickly only if we handle them seriously. City traffic noise, for example, has been a difficult problem for many years. In Beijing, Mayor Chen Xitong [7115 1585 0681] took the lead in prohibiting motor vehicles from blowing their horns, and many cities followed this example in succession. That quickly lowered the noise in many cities, which decreased an average of 3-7 decibels. The effect is rather obvious. It is the same with controlling river pollution and advocating a central heating supply and air pollution control; great advances were obtained. This explains that to do practical work and expect results are surely good tendencies worth advocating, and they are also important working methods. As long as the governments of various levels, the related departments and the departments of environmental protection of various levels insist on this way, finish some work and solve some problems every year, and persevere, after a period of time, we believe in less than a few years, the appearance of our environment will change greatly.

To administer pollution control requires money, but this should not become an obstacle which affects the policy of achieving what is practical. Experiences from various places prove that money raising and voluntary labor can solve a lot of problems. In several cities, river bed cleaning and gas pipelines were done this way. It is very effective and has changed the method used in the past of asking the state to pay whenever some work needed to be done. In collecting the money, we must insist on the principle that "whoever pollutes must administer." Polluters have the responsibility to administer the environmental policy without excuses, and they should shoulder their deserved share. Added to the necessary subsidies from local governments, there emerges a channel for funds.

Based on the results of doing the practical in various places, we know that establishing gas networks, using centralized heating supplies, administering river beds, establishing waste water processing, controlling noise and

closing, stopping, emerging, transferring and moving some factories or plants are all advantageous to the reform of the city. To use technological reform to administer the environment of industry and enterprises is also helpful to the conservation of resources and energy, is advantageous in raising the quality of the product, has the effect of accelerating economic development and of realizing the synchronous development of economic construction, urban and rural construction and environmental construction and realizes the unification of economic, social and environmental interests.

Over a year's practice in the past has shown that doing the practical and expecting results are surely good and effective working methods. In doing this, not only is confidence in administering environmental pollution built but also it is well received by the masses. We should have this method popularized and make it routine and institutionalized. Based on this idea, we drafted the "Suggested Tasks for Environmental Protection for 1985" and called a panel to solicit opinions from related departments. Later these "Suggestions" were submitted to the National Environmental Protection Conference for discussion. Based on all the opinions, we made some revisions and the draft submitted to this conference for consideration is the third revision.

II. Starting Point of the "Suggestions"

In several conferences, Comrade Li Peng stressed again and again the importance of doing the practical. He said: "We ask the governors, mayors, magistrates and ministries to do some good work for the people on environmental protection within their terms of office. If one city or one town a year could do three to five projects in environmental protection whose practical result can be seen by the masses, it would be an impetus to the leaders and an examination and would also strengthen the confidence of the people in the prevention and control of pollution." Based on the spirit of Li Peng's directive, we drafted these "Suggestions." There exist many environmental problems in various places, and it is impossible to promote all. Besides, our state is not rich enough and we cannot expect too much. Our suggestions are mainly to stimulate administration through the strengthening of environmental control. The starting point of our consideration is:

1. These are several specific practical tasks to be done in 1985; it is not the overall work arrangement for this year, nor is it the overall work assignment in environmental protection for the various ministries or districts.
2. The suggested tasks deal with outstanding problems which cause the most concern to the people and can be solved at present.
3. The suggested tasks are those which will not cost too much and are easily executed and solved. Those which cannot be solved currently are not listed.
4. We must put forward some specific goals and requests for the annual examination at the end of this year.

III. Some Explanations

1. Tasks to be done by every provincial, autonomous region and municipal government:

(1) The problem of air pollution. At present the most prominent air pollution problem is the soot pollution created by the burning of coal. So the effective way to control soot pollution is to establish soot control areas. By soot control area (in some places it is called a non-smoke area), we mean that there is no smoke from burning facilities in this area and the discharge of dust must meet certain criteria. It resembles the experience of Hangzhou Municipality, which was introduced in this conference and which achieved good results, and we hope to popularize this experience. At present, popularizing molded coal is an important measure in preventing and administering soot pollution; it is a feasible method which suits the circumstances of our nation. In every place, the construction of molded coal experimental plants should be established as soon as possible, combined with electricity and coal conservation.

(2) The problem of environmental monitoring. Environmental monitoring is the ear and eye of environmental protection, and it is also the prerequisite for good environmental control. At the present stage, the key to environmental protection is to stress environmental control, and then a step-by-step transition to quantitative control. This requires good monitoring work. Therefore, we ask every province, autonomous region and municipality to complete the construction of three to five city or county monitoring stations, and more stations where the conditions are available, in order to accelerate construction as fast as possible. By completion we mean that the basic construction should be finished and the organization should be healthy, be able to do the routine monitoring work according to the specifications, complete survey data about polluters and be able to monitor pollution. And it has to pass the monitoring work qualifying examination.

(3) The problem of the prevention of rural enterprise pollution. The expansion of rural enterprises has had great importance for the increase of peasant commodities and the rise of peasant living standards. It is an important way for the masses to get rich. We must vigorously assist the development of rural industry, but at the same time be able to see that because of the weakness of rural enterprises in technology, lack of capital and backwardness in industry, environmental pollution and ecological destruction often result. This has occurred in many places. Therefore, we must enthusiastically take the lead, finish the overall arrangement and adjust the structure of production. Whatever creates serious environmental pollution and ecological destruction must be strictly restrained. The experience of Shunde County is proof that as long as the leaders emphasize strengthening environmental control and strictly execute the environmental regulations, not only can pollution be controlled and the rural ecological environment be preserved, but rural enterprises can also be quickly developed. Their experience has great significance. We suggest that every provincial, autonomous region and municipal people's government use this experience as its mirror and establish some rural enterprise pollution control test points in at least one county. If we

do not pay attention to this problem as soon as possible, the consequences will be severe.

2. Tasks to be done by the national industrial and transportation departments:

Industrial pollution is a big polluter which creates environmental pollution in our country, so it is an important point. To prevent and control industrial pollution by combining technological improvements to solve the pollution problem of old enterprises is the focal point of the "Seventh 5-year Plan. We hope that every department will establish model factories (including clean factories) or workshops and offer experiences for later technological improvements. Last year at the Second Conference of the State Council Environmental Protection Committee, we decided that the seven ministries should try the "experimental measures of index for the assessment of industrial and enterprise environmental protection," and we hope that these ministries will be serious in the organization of the test points and summarize the experiences to facilitate its popularization in the whole country.

3. Tasks to be done by the other ministries:

(1) The problem of agricultural ecology development. The development of agricultural ecology is an important direction for the development of international and local agriculture; it can stimulate the beneficial cycle of agricultural ecology, both to increase production and to protect the environment, thus killing two birds with one stone. Last year this ministry and the Ministry of Agriculture, Animal Husbandry and Fisheries jointly called a conference to exchange experiences on national agricultural ecological environmental protection, and we summarized some of these experiences. We hope the Ministry of Agriculture, Animal Husbandry and Fisheries will this year establish with provincial and municipal and environmental protection-related ministries a group of new models and summarize some new experiences in order to expand this work further.

(2) Examination and assessment of the effects of environmental pollution on human health. This is a very important measure to understand the dangers created by environmental pollution; one of the important bases is to formulate environmental policy. Some of these tasks have been done by the Ministry of Public Health, but it is far from enough, and we hope that the ministry can expand that work this year.

4. Tasks to be done by all state organs.

(1) Examination of "three simultaneously's". "Three simultaneously's" have been repeatedly instructed by the state, but its execution is still not satisfactory. We are considering having a one-time examination jointly arranged by the State Planning Commission and the State Environmental Protection Bureau to expand this work further.

(2) General investigation of polluters. The truth of industrial pollution in the whole country is still not clear to us, and this is disadvantageous to understanding the situation of pollution and the measures taken for

prevention and cure. Therefore, we suggest that the State Economic Commission combine with the national industry general investigation to get a clear idea of the types and number of pollutants from large and medium-size industries to be used as a basis for industrial pollution prevention and cure.

(3) Establishment of models. Technological reform is managed centrally by the State Economic Commission, and the State Economic Commission should, through technological reform and the administration of environmental pollution, establish some model factories and model enterprises.

5. Tasks to be done by the State Environmental Protection Bureau:

The practical work to be done by the State Environmental Protection Bureau mainly includes two areas: the first is to maintain the three models, that is, Hangzhou, Luoyang and Shunde. These models are both municipal and county. Hangzhou is a famous scenic city for tourists. The requirement in environmental quality is higher and its good administration has a great influence inside and outside of the country. Luoyang is both an ancient capital city with many places of historic interest and scenic beauty and a newly emerged industrialized city since Liberation. If the environmental protection work is done well, it will be universally significant as a leader of environmental protection for the mid-size industry of the whole nation. In Shunde County, enterprise is flourishing and environmental protection is also done well. It is a place where the rural mulberry tree-based fish pond system is very famous. We have confidence that their experience in solving the problems of rural enterprise pollution and the protection of the agricultural environment will play a positive role. Second, we should establish a group of model engineering projects, including demonstration projects for molded coal and oxidation ponds. World Environmental Protection Day is an activity initiated by the United Nations and we want to use this chance to advance our propaganda work for environmental protection.

My fellow commissioners, the above is my explanation of the "Suggestions," which is submitted to you for consideration.

12909
CSO: 4008/340

ENVIRONMENTAL QUALITY

GUANGZHOU'S ANTIPOLLUTION CAMPAIGN PAYS OFF

OWO61313 Beijing XINHUA in English 1152 GMT 6 Jun 85

[Text] Guangzhou, 6 Jun (XINHUA)--Guangzhou has scored major successes in its battle against pollution over the past 5 years--despite a big rise in industrial production, the city's environmental protection office said Wednesday.

As the city celebrated the first international environment day, officials said that dust content in the air had been reduced by 7.8 percent since 1980 to become the lowest in China's major cities. Meanwhile, the city's industrial output value had risen by 52 percent during the same period.

Discharges of industrial waste water were down 6.2 percent. Among industrial pollutants, the amount of cyanide has been cut by nearly 50 percent, phenol by 76.5 percent, chromium by 85 percent and lead by 85.4 percent.

Although the number of motor vehicles using city streets doubled between 1980 and 1984, the noise output fell by about four decibels, according to the officials.

The officials attributed the achievements to the following measures:

--The implementation of five municipal regulations controlling noise, protecting water resources and reducing discharges of pollutants, while state laws and decrees on environmental protection have been carried out.

--The raising of 53 million yuan by local authorities and enterprises for pollution control last year.

--The import of advanced technology and equipment, which has helped reduce the discharge of pollutants.

--And efforts by the city government to control the volume of waste water from the 83 major polluters in the city last year.

The officials forecast that Guangzhou would have the problem of pollution under control within 5 years.

CSO: 4010/2002

ENVIRONMENTAL QUALITY

LIAONING SUCCESS IN POLLUTION CONTROL NOTED

OW121857 Beijing XINHUA in English 1812 GMT 12 Jun 85

[Text] Shenyang, 12 Jun (XINHUA)--Smoke pollution has been brought under control over the past 4 years in Liaoning Province, a heavy industrial base in Northeast China, according to a meeting on the problem which just closed here.

Data from air monitoring stations in 12 major cities show that the amount of dust, sulfur dioxide and nitrogen oxide in the air last year still remained at the 1980 level, though their industrial output value went up by 26.7 percent and coal consumption, by 92.5 percent. This was achieved through centralizing the domestic heat supply, using natural gas and liquefied petroleum gas, and renovating furnaces, said an official of the province's Environmental Protection Bureau.

Centralized heat supply systems covered 15.7 million square meters in 1984, as against 2.69 million in 1979, he said. This has not only saved the province 300,000 tons of coal a year but also reduced the discharge of soot by 15,000 tons and sulfur dioxide by 9,000 tons.

In Tiexi district, Shenyang City, the content of sulfur dioxide has been reduced from 0.154 mg per cubic meter of air to 0.045 mg at present, and the dust ratio has fallen below the state standard. Now the province is constructing 23 more centralized heat supply systems in major cities, which will dispense with 2,000 boilers.

In the 12 major cities gas is now available for 45 percent of urban families, with the highest rate of 77 percent in Fushun where gas is being extracted from coal mines to supply 120,000 households with cooking fuel.

The province has renovated 42 percent of its 26,900 industrial boilers and kilns which used to cause heavy pollution.

As a result, the province's metallurgical industry has updated 760 furnaces and the amount of dust discharged has been reduced from 71 tons in 1981 to 36 tons last year.

CSO: 4010/2002

ENVIRONMENTAL QUALITY

THERMAL POWER PLANTS REDUCE POLLUTION

OW130846 Beijing XINHUA in English 0755 GMT 13 Jun 85

[Text] Beijing, 13 Jun (XINHUA)--China's state-owned thermal power plants have reduced dust pollution to under 10 percent in the past decade. This was shown at an 8-day national exhibition on environmental protection in power industry featuring dozens of research results in the past few years in cleaning and utilizing power plant residue that closed here on Wednesday.

Exhibition achievements, said Vice-Minister Zhang Fengxiang of water conservancy and electric power, "are no less advanced than those in foreign countries." But, he continued, "the problem now is how to put them into wide use quickly."

Thermal power plant residue consists of dust, sewage and slag, polluting air, soil and water. Dust discharged into atmosphere was reduced by one third last year, and slag sent into rivers fell by 70 percent.

However, sewage remains a problem, according to Shi Ti, director of the environmental protection office under the ministry. "But efforts are being made," he said in an interview with XINHUA today. Residue from coal-fired plants, which account for 90 percent of the country's thermal power plants, used to be discharged with virtually no treatment before 1975, he added.

The Chinese Government called for environmental protection and the ministry set up the office to tackle power plant pollution in 1975. Environment protection offices or research institutes have been set up in provinces, and regulations made to punish plants that fail to meet the standards.

China has found about 100 ways to use fly ash and slag from thermal power plants, Shi Ti said, and one quarter of such pollutants were recycled last year as building and road construction materials, plastics, chemical fertilizers and land-fills.

"Fly ash and slag are no longer a 'big headache'; they are the third product of our thermal power industry," Shi Ti said. The other two products are electricity and gas.

The vice-minister also pointed to simple measures that can be highly effective. Raising the height of the smokestack or using low sulphur coal can also reduce air pollution, he said.

Representatives from all the ministries, related research offices or institutes and power plants visited the exhibition.

CSO: 4010/2002

ENVIRONMENTAL QUALITY

BRIEFS

ENVIRONMENTAL PROTECTION EXHIBIT CLOSES--Beijing, 15 Jun (XINHUA)--Over 5,000 purchasers and experts attended the first national sales exhibition of environmental protection equipment, which closed here this afternoon after an 11-day run. Sponsored by the China Construction Technology Development Center, the exhibition was one of 13 similar ones held around international environment day. Nearly half the 370 new products were for harmful gases and the rest for treating water, controlling noise and monitoring contamination. They were from 140 factories in 24 provinces and municipalities. [Text] [Beijing XINHUA in English 1315 GMT 15 Jun 85]

QAIDAM BASIN SALT LAKES--Xining, 24 May (XINHUA)--A survey conducted by the Qinghai Salt Lake Research Institute has put the number of such lakes in the Qaidam Basin, northwest China, at 33, said a local scientist today. In the 1950s there were 25 salt lakes in the Qaidam Basin, Chen Kezao, associate research fellow of the institute added. The area of salt deposits amounts to over 30,000 sq km, one-fourth of the total area of the basin. The survey, started in 1982 by the institute under the Chinese Academy of Sciences, shows that the basin has 41 lakes, classified into salt lake, freshwater or brackish lake, and playas. Of the 33 salt lakes, 27 have a salt content of 50 or more grams per liter, and the other six are playas. Qarhan Salt Lake, covering 5,856 sq km, is the biggest playa in the world. It also ranks first in the country for its deposits of sylvite. There is a trend for the freshwater lakes to become saltier as the annual evaporation rate in the Qaidam Basin is above 3,000 mm, or more than 140 times the average annual rainfall in the area, said Chen Kezao. Therefore, more playas are slowly being formed all the time. [Text] [Beijing XINHUA in English 0720 GMT 24 May 85]

NEI MONGGOL UNDERGROUND LAKES--Beijing, 24 May (XINHUA)--A team of People's Liberation Army engineers from Beijing has discovered six large underground mineral water lakes beneath the Xilin Gol grassland in Inner Mongolia. The discovery was made during a recent geological survey of the area, an official from the PLA unit involved said here today. The lakes, 50 to 60 meters underground, have a total surface area of about 1,000 square kilometers. Chemical analysts say the water contains carbon dioxide and traces of silica and other minerals, and that it should be good for making soft drinks and treating certain skin complaints. [Text] [Beijing XINHUA in English 0726 GMT 24 May 85]

FREQUENCY OF ACID RAIN INCREASES--Shanghai, 30 May (ZHONGGUO XINWEN SHE)--Of every 100 rainfalls in Shanghai last year, 42 were acid rains. According to residents, at present, whenever it rains, they can smell the strange smell of sulfur dioxide. Shanghai began to have acid rain in 1980. Of every 100 rainfalls then, 6 were acid rains. In Shanghai, the range and intensity of acid rain is increasing. In 1980, of 15 acid rain monitoring centers, only 8 discovered acid rains. Now they all have discovered acid rains. The acid rains in Shanghai are caused by air pollution resulting from industrial soot. The six power plants alone in Shanghai eject as much as 270,000 tons of sulfur dioxide into the air every year through soot. The frequency of acid rain in Shanghai has aroused the attention of environmental protection departments. Since last year, Shanghai has begun to transform furnaces and kilns in Nanshi, Jingan, Huangpu, Luwan, Xuhui, and Putuo, in an effort to dispel smoke and eliminate dust. This year, activities to harness black smoke have been set off throughout the city. Meanwhile, the municipal government is also considering changing the energy base of some large factories and using natural gas and oil to replace coal, which results in serious smoke and dust pollution. [Text] [Beijing ZHONGGUO XINWEN SHE in Chinese 0921 GMT 30 May 85 HK]

CSO: 4008/2001

AUTHOR: CHENG Yibing [4453 0001 0365]
XIA Yuanfu [1115 0337 1788]
et al.

ORG: CHENG, et al., of the Department of Silicate Materials, Wuhan Institute of Building Materials; XIA, et al., of the Department of Physics, Nanjing University

TITLE: "Investigation of Structural Effect of Fe^{3+} in Sodium Silicate Glasses"

SOURCE: Beijing GUI SUANYAN XUEBAO [JOURNAL OF THE CHINESE SILICATE SOCIETY] in Chinese Vol 12 No 4, Dec 84 pp 395-403

TEXT OF ENGLISH ABSTRACT: The coordination states of Fe^{3+} , B^{3+} and Al^{3+} ions in silicate glasses have been determined respectively by means of Mössbauer spectroscopy, infrared spectroscopy and a fluorescence X-ray diffractometer. The structural effect induced due to the coexistence of these cations in the glasses and the influence of the iron and boric oxide anomaly on the glass density are discussed.

The results indicate that boric oxide cannot change the coordination of ferric ions, and iron oxide has the ability to convert $[BO_4]$ tetrahedron into $[BO_3]$ trihedron in the silicate glasses containing Fe_2O_3 and B_2O_3 . In the silicate glasses in which the sum of Fe_2O_3 , Al_2O_3 and B_2O_3 content is more than the alkali oxide content, the tetrahedra-forming ability of these cations decreases in the order of $Al^{3+} \rightarrow Fe^{3+} \rightarrow B^{3+}$.

AUTHOR: GE Dunshi [5514 2415 0013]
LOU Zonghan [2869 1350 3352]
et al.

ORG: GE, et al., of the Nanjing Research and Design Institute for Fiberglass Industry; LOU, et al., of Zhejiang University

TITLE: "A Study of Alkali Resistance of CaO-Al₂O₃-SiO₂ Glasses"

SOURCE: Beijing GUI SU ANYAN XUE BAO [JOURNAL OF THE CHINESE SILICATE SOCIETY] in Chinese Vol 12 No 4, Dec 84 pp 411-418

TEXT OF ENGLISH ABSTRACT: Alkali resistance and structure of CaO-Al₂O₃-SiO₂ glasses are studied in this paper. The coordination number change of aluminum ions in the glasses, caused by corrosion of cement extract aqueous solution, was determined through X-ray fluorescence spectra and infrared absorption spectra. The correlation between glass composition, structure and alkali resistance is discussed.

AUTHOR: YANG Huarui [2799 5478 5605]
QIU Xibai [6726 1585 4101]
et al.

ORG: YANG, et al., of the Institute of Geology, Chinese Academy of Sciences; QIU of Beijing Research Institute of Uranium Ore Processing

TITLE: "A Study of Zeolite Ld-Steel Slag Cement by the Trimethylsilylation Method"

SOURCE: Beijing GUI SUANYAN XUEBAO [JOURNAL OF THE CHINESE SILICATE SOCIETY] in Chinese Vol 12 No. 4, Dec 84 pp 423-428

TEXT OF ENGLISH ABSTRACT: An improved TMS method is used to study zeolite Ld-steel slag cement. The characteristics of hydration and the function of zeolite are further investigated by determining the polymerization of cement clinker, steel slag and zeolite rock, and also by comparing the change in polymerized silicon states in the cement pastes at different ages from the first day to the third month.

In addition, the composition of the lime-zeolite cement paste is compared to that of lime-calcined zeolite cement paste, confirming that the calcination of zeolite can accelerate hydration.

AUTHOR: GUAN Zhenduo [7070 2183 6995]

ORG: Qinghua University

TITLE: "Study of K_{IC} Measurement by Use of Short Chevron-notched Bar Specimen"

SOURCE: Beijing GUI SUANYAN XUEBAO [JOURNAL OF THE CHINESE SILICATE SOCIETY]
in Chinese Vol 12 No 4, Dec 84 pp 456-463

TEXT OF ENGLISH ABSTRACT: A solution for the differential equation of specimen compliance in the critical state is derived for a short chevron-notched bar splitting specimen by the fracture work method. It is proved by the compliance calibration test that the optimum regression equation for compliance values can be obtained according to the theoretical solution. The K_{IC} expression is then derived. It is also proved through experimentation that the K_{IC} value obtained is similar to that obtained by use of the chevron-notched bar specimen. Finally, the effect of geometric dimensions of the specimen on the K_{IC} value is discussed.

AUTHOR: LIU Yanling [0491 1693 0134]

ORG: Luoyang Institute of Refractories Research, Ministry of Metallurgical Industry

TITLE: "Tensile Creep Behavior of Magnesia-Alumina Bricks at High Temperatures"

SOURCE: Beijing GUI SUANYAN XUEBAO [JOURNAL OF THE CHINESE SILICATE SOCIETY] in Chinese Vol 12 No 4, Dec 84 pp 464-471

TEXT OF ENGLISH ABSTRACT: The tensile creep behavior of magnesia-alumina bricks at the temperature range of from 1300°C to 1400°C is studied. The average apparent activation energy and stress index (for tensile creep) of the magnesia-alumina brick were determined by the single-specimen and multi-specimen methods respectively in the above temperature range and under stress of 0.5 kg/cm² to 7 kg/cm². It is considered that the creep behavior is basically controlled by viscous deformation. In the present investigation, it is found that 1370±2°C is the transition temperature for creep behavior of the magnesia-alumina brick, which is attributed to the formation of the liquid phase in the brick in this temperature range.

AUTHOR: XU Bin [1776 2430]
et al.

ORG: Institute of Crystal Materials, Shandong University

TITLE: "The Growth and Piezoelectric Properties of a New Kind of Piezoelectric Material--High Quality α -AlPO₄ Single Crystals"

SOURCE: Beijing GUI SUANYAN XUEBAO [JOURNAL OF THE CHINESE SILICATE SOCIETY]
in Chinese Vol 12 No 4, Dec 84 pp 472-477

TEXT OF ENGLISH ABSTRACT: The growth conditions of high quality α -AlPO₄ single crystals by a hydrothermal method are described in this paper. The crystal defects were observed using the common optical method, and the piezoelectric constants and some elastic constants were also determined.

AUTHOR: LI Baoxiang [2621 1405 4382]
et al.

ORG: Institute of Applied Chemistry, Chinese Academy of Sciences, Changchun

TITLE: "Study of Ferroelastic Transition in $\text{LnP}_5\text{O}_{14}$ "

SOURCE: Beijing GUI SUANYAN XUEBAO [JOURNAL OF THE CHINESE SILICATE SOCIETY]
in Chinese Vol 12 No 4, Dec 84 pp 478-482

TEXT OF ENGLISH ABSTRACT: The ferroelastic properties of $\text{LnP}_5\text{O}_{14}$ (Ln:La→Dy) crystal were studied by means of a high-temperature-microscope and a stressometer with a sensor element. The phase transition temperatures and critical shear stress for the rearrangement of the ferroelastic domains of the $\text{LnP}_5\text{O}_{14}$ crystal were also determined. In addition, the configuration, type and orientation of the domains were observed using the X-ray-Laue and optical methods. The influences of ferroelastic domains on optical homogeneity and laser properties were also studied.

AUTHOR: ZHANG Renhua [1728 0088 0553]
LIU Jinghe [0491 2529 0735]
et al.

ORG: ZHANG, et al., of Changchun Institute of Optics and Fine Mechanics,
Chinese Academy of Sciences; LIU of Changchun College of Optics and Fine
Mechanics

TITLE: "A Study of Cracking in Large BaF₂ Crystals"

SOURCE: Beijing GUI SUANYAN XUEBAO [JOURNAL OF THE CHINESE SILICATE SOCIETY]
in Chinese Vol 12 No 4, Dec 84 pp 483-489

TEXT OF ENGLISH ABSTRACT: Factors affecting cracking of large BaF₂ single
crystals during the growth process are examined. The allowable maximum
axial temperature gradient, rate of cooling and maximum resultant strain due
to thermal stress during the growth of the crystals are also discussed.

Perfect crystals with diameters of 100 mm, free of cracks, were obtained by
improving the temperature field and establishing the optimum growth process
for the Bridgman-Stockbarger method.

AUTHOR: JIANG Yasi [5592 0068 4828]
et al.

ORG: Shanghai Institute of Optics and Fine Mechanics, Chinese Academy
of Sciences

TITLE: "Preparation Techniques of Phosphate Laser Glass"

SOURCE: Beijing GUI SUANYAN XUEBAO [JOURNAL OF THE CHINESE SILICATE SOCIETY]
in Chinese Vol 12 No 4, Dec 84 pp 494-498

TEXT OF ENGLISH ABSTRACT: Phosphate glass has been widely used in lasers, especially in high power laser systems, due to its high gain coefficient, low n_2 and athermal properties. Recently, a few high power laser systems have been built in the world for investigating fusion and laser interaction with plasma.

In order to satisfy the special technological properties of phosphate glass, such as high volatility, low viscosity and high tendency toward devitrification, a series of preparation techniques, including a hermetic platinum melting system with special stirrer, water removal from the glass melt and a flow-casting process have been developed to produce low loss, long lifetime, optically homogeneous glass blanks with large dimensions. A melting facility has been built and the laser glass produced has been used in rod laser amplifiers, up to 70 mm in diameter, and disk laser amplifiers, up to 200 mm in aperture.

AUTHOR: YU Lihang [0205 0500 5300]
YANG Hongning [2799 3163 1337]
et al.

ORG: YU of Shanghai Research Institute of Building Sciences; YANG, et al.,
of Shanghai Jiaotong University

TITLE: "Theoretical Calculation of Optical Damage to LiNbO₃ Crystals of
High Purity"

SOURCE: Beijing GUI SUANYAN XUEBAO [JOURNAL OF THE CHINESE SILICATE SOCIETY]
in Chinese Vol 12 No 4, Dec 84 pp 499-503

TEXT OF ENGLISH ABSTRACT: The mechanism of optical damage to LiNbO₃ crystals
of high purity is described in this paper. It is found that variation of
spontaneous polarization brings about a change in the birefringence of beams
in crystals illuminated by higher power laser beams due to the crystal's
ferroelectric behavior. It is also found that the factors affecting the
variation of spontaneous polarization are photoionization, thermal ionization
and the pyroelectric effect, all of which have the same significance. A
formula for calculating this kind of optical damage is established in the
paper as follows:

$$\Delta n_3 = -f_{33} n_3^3 p (N_t - n_{t\infty}) \{1 - \exp[-(A_{11} + B_{21} C_1) t]\}$$

and the maximum steady-state value (-2.47×10^{-3}) for optical damage to the
sample is obtained. The results of our theoretical research are basically
consistent with the known experimental results.

9717
CSO: 4009/1026

END