

NAVAL POSTGRADUATE SCHOOL
Monterey, California



THESIS

**ENVIRONMENTAL SENSITIVITY STUDY
ON MINE IMPACT BURIAL
PREDICTION MODEL**

by

Victoria L. Taber

March 1999

Thesis Advisor:
Second Reader:

Peter C. Chu
Steve Haeger

Approved for public release; distribution is unlimited.

1 9 9 9 0 4 1 5 0 0 3

REPORT DOCUMENTATION PAGE

Form Approved
OMB No. 0704-0188

Public reporting burden for this collection of information is estimated to average 1 hour per response, including the time for reviewing instruction, searching existing data sources, gathering and maintaining the data needed, and completing and reviewing the collection of information. Send comments regarding this burden estimate or any other aspect of this collection of information, including suggestions for reducing this burden, to Washington headquarters Services, Directorate for Information Operations and Reports, 1215 Jefferson Davis Highway, Suite 1204, Arlington, VA 22202-4302, and to the Office of Management and Budget, Paperwork Reduction Project (0704-0188) Washington DC 20503.

1. AGENCY USE ONLY (Leave blank)	2. REPORT DATE March 1999	3. REPORT TYPE AND DATES COVERED Master's Thesis
---	-------------------------------------	--

4. TITLE AND SUBTITLE ENVIRONMENTAL SENSITIVITY STUDIES ON MINE IMPACT BURIAL PREDICTION MODEL	5. FUNDING NUMBERS
--	---------------------------

6. AUTHOR(S) Taber, Victoria L.	N6230698OB80001
---	-----------------

7. PERFORMING ORGANIZATION NAME(S) AND ADDRESS(ES) Naval Postgraduate School Monterey, CA 93943-5000	8. PERFORMING ORGANIZATION REPORT NUMBER
---	---

9. SPONSORING / MONITORING AGENCY NAME(S) AND ADDRESS(ES) NAVOCEANO, Stennis Space Center, MS 39522-5001	10. SPONSORING / MONITORING AGENCY REPORT NUMBER
--	---

11. SUPPLEMENTARY NOTES
The views expressed in this thesis are those of the author and do not reflect the official policy or position of the Department of Defense or the U.S. Government.

12a. DISTRIBUTION / AVAILABILITY STATEMENT Approved for public release; distribution is unlimited.	12b. DISTRIBUTION CODE
--	-------------------------------

13. ABSTRACT (maximum 200 words)

The Navy's Impact Burial Prediction Model creates a two-dimensional time history of a bottom mine as it falls through air, water, and sediment. The output of the model is the predicted burial depth of the mine in the sediment in meters, as well as height, area and volume protruding. Model input consists of environmental parameters and mine characteristics, as well as parameters describing the mine's release. The model user seldom knows many of these parameters, and those that are known may be of questionable precision.

In order to determine which parameters had the greatest effect on the model and which could be simplified or eliminated, a series of sensitivity tests were performed. It was found that the model data ingest could be greatly simplified without sacrificing accuracy too much. However, several parameters including sediment shear strength were found to have a large effect on the model and were investigated further.

14. SUBJECT TERMS Modeling and Simulation, Meteorology and Oceanography, METOC, Mine Impact Burial Prediction, Bottom Mine, Decision Making	15. NUMBER OF PAGES 67
---	----------------------------------

	16. PRICE CODE
--	-----------------------

17. SECURITY CLASSIFICATION OF REPORT Unclassified	18. SECURITY CLASSIFICATION OF THIS PAGE Unclassified	19. SECURITY CLASSIFICATION OF ABSTRACT Unclassified	20. LIMITATION OF ABSTRACT UL
--	---	--	---

Approved for public release; distribution is unlimited.

**ENVIRONMENTAL SENSITIVITY STUDIES ON MINE IMPACT
BURIAL PREDICTION MODEL**

Victoria L. Taber
Lieutenant, United States Navy
B.S., Purdue University, 1994

Submitted in partial fulfillment of the
requirements for the degree of

**MASTER OF SCIENCE IN METEOROLOGY AND
PHYSICAL OCEANOGRAPHY**

from the

NAVAL POSTGRADUATE SCHOOL

March 1999

Author: _____



Victoria L. Taber

Approved by: _____

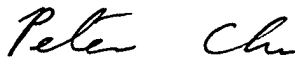

Peter C. Chu, Thesis Advisor

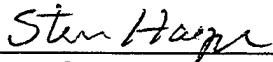

Steve Haeger, Second Reader



Roland W. Garwood, Jr., Chair
Department of Oceanography

ABSTRACT

The Navy's Impact Burial Prediction Model creates a two-dimensional time history of a bottom mine as it falls through air, water, and sediment. The output of the model is the predicted burial depth of the mine in the sediment in meters, as well as height, area and volume protruding. Model input consists of environmental parameters and mine characteristics, as well as parameters describing the mine's release. The model user seldom knows many of these parameters, and those that are known may be of questionable precision.

In order to determine which parameters had the greatest effect on the model and which could be simplified or eliminated, a series of sensitivity tests were performed. It was found that the model data ingest could be greatly simplified without sacrificing accuracy too much. However, several parameters including sediment shear strength were found to have a large effect on the model and were investigated further.

TABLE OF CONTENTS

I. INTRODUCTION.....	1
II. DYNAMICAL ANALYSIS OF A CYLINDRICAL MINE	5
A. GEOMETRY OF A CYLINDRICAL MINE.....	5
B. ATTITUDE OF A CYLINDRICAL MINE.....	6
C. ADDED MASS.....	6
D. PROJECTED AREA	7
E. DRAG COEFFICIENT.....	8
1. Drag Coefficient for a Circular Cylindrical Mine	9
2. Drag Coefficient for a Tapered or Round-Nosed Cylindrical Mine.....	9
III. MOMENTUM BALANCE OF A CYLINDRICAL MINE IN AIR AND WATER. 11	
A. EQUATION OF MOTION	11
B. MINE ENTRY INTO WATER.....	11
1. Cavity Regime	12
2. Fully Wetted Regime	13
C. MINE BURIAL IN SEDIMENT.....	13
1. Viscosity and Shear Strength.....	13
2. Mine Burial Dynamics.....	14
IV. MINE IMPACT BURIAL PREDICTION MODEL.....	15
A. DEVELOPMENT HISTORY	15
B. IB MODEL INPUT PARAMETERS.....	16
C. AIR AND WATER PHASES.....	18
D. SEDIMENT PHASE.....	19
1. Bearing Strength.....	20
2. Hydrodynamic Drag in Sediment	20
3. Buoyancy in Sediment.....	21
E. ENVIRONMENTAL PARAMETERS IN THE IB MODEL.....	21
V. SENSITIVITY STUDY FOR THE CYLINDRICAL MINE.....	27
A. SENSITIVITY TO RELEASE MEDIUM PARAMETERS.....	27
B. SENSITIVITY TO SEDIMENT CHARACTERISTICS.....	29
1. Sensitivity to Shear Strength and Density	29
2. Simulated Sediment Profiles	30
VI. RECOMMENDATIONS.....	45
LIST OF REFERENCES	47
INITIAL DISTRIBUTION LIST	49

LIST OF FIGURES

- Figure 1. The trajectory of a cylindrical mine as it falls through three phases: air, water and sediment. Labels on the right are parameters used by the model to calculate velocity, attitude, and burial depth of the cylinder2
- Figure 2. Horizontal length, L_h , as a function of cylinder diameter and length, D and L , and attitude Φ . Rotation rate, ω , determines the attitude at a given time 5
- Figure 3. Parameters used to compute projected lengths and projected area. 8
- Figure 4. Sensitivity of IB predicted burial depth (m) to various mine types. Characteristics of mine types are in table 1.....24
- Figure 5. Scatter diagram of sixty-two pairs of density (kg/m^3) and shear strength (kPa) data. Shear strength values are most dependent on percentage of clay and time since deposition. Data obtained from Voelkner (1979) and Mulhearn (1993).....25
- Figure 6. Derivative plot of all four output parameters from one IB model run. Notice the shape of each derivative plot is similar, confirming that one can be used to represent sensitivity levels of all output parameters. Burial depth was examined in the study for this paper, as it is the primary result obtained by the model. 34
- Figure 7. Effect of release altitude (m), water depth (m) and water temperature ($^{\circ}\text{C}$) on predicted burial depth (m). Values were preliminarily chosen to represent all conditions under which the IB model may be used.36
- Figure 8. Three-dimensional plot of burial depth (m) and height protruding (m) as both release altitude (m) and water depth (m) are varied. Height protruded is illustrated here to clarify the levels at which these parameters become less influential in the IB prediction.37
- Figure 9. Sediment profiles of density (kg/m^3) and shear strength (kPa) used in the sensitivity study. Data obtained from Mulhearn (1993).....39
- Figure 10. Effect of density and shear strength on burial depth. Density change only impacts the predicted burial depth in very soft sediments. As expected, shear strength has a dramatic impact on predicted burial depth. 41
- Figure 11. Effect of α and β coefficients on predicted burial depth (m)..... 42

Figure 12. Contour plots of predicted burial depth (m) with respect to α and β coefficients. Asterisks mark the values of α and β that correspond to the three sediment profiles used in the study.....43

LIST OF TABLES

Table 1: Parameters for mines that are available for selection in the model. Center of mass offset difference can also be specified (in meters) but is 0 for all selections available in the IB model.	17
Table 2. Effect of wave height on burial depth. Wave heights were set around a mean water depth and release altitude was selected to represent a ship or aircraft delivery. If released from 150 meters, wave height has little effect. If released from near the water surface, wave height upon release has a significant impact if the depth/wave height ration is high.....	23
Table 3. Maximum and minimum burial values for a mine released from 1.5 or 150 meters. An initial fall angle and subsequent sediment impact angle of 0° indicates a perpendicular orientation and maximum burial depth. Fall angle of 90° indicates the mine is parallel to the sediment and yields a minimum burial depth.	28
Table 4. Values calculated using equations derived by fitting a polynomial to known density and shear strength profiles. The precision of this simplified method of depicting a sediment profile is demonstrated in table 5.	31
Table 5. Predicted burial depths using manufactured profiles based on measured values at the interface.....	32

TABLE OF SYMBOLS

Φ	=	Angle with respect to the vertical; Attitude of cylinder (degrees)
Φ^*	=	Steady-state attitude (degrees)
κ	=	Inertial coefficient
Λ	=	Kinematic viscosity
ρ	=	Density (kg/m^3)
ω	=	Rotation rate of cylinder (degrees/sec)
A	=	Projected Area
A_h	=	Area projected on horizontal (m^2)
A_v	=	Area projected on vertical (m^2)
A_w	=	Standard wetted area of a cylinder
B	=	Volume (m^3)
C_D	=	Drag coefficient
C_F	=	Coefficient for skin friction
cb	=	Center of buoyancy
cg	=	Center of gravity
d	=	Cavity depth (m)
D	=	Maximum diameter of cylinder (m)
D_B	=	Diameter of base of cylinder (m)
f_D	=	Void force
F_b	=	Force due to buoyancy
F_c	=	Cumulative force
F_s	=	Shear force
$F_{w,a}$	=	Force from air weight of mine
g	=	Gravity (m/s^2)
h	=	Depth in sediment
L	=	Length of cylinder (m)
L_h	=	Projected length with respect to the horizontal (m)
L_v	=	Projected length with respect to the vertical (m)
M	=	Mass (kg)
M_{added}	=	Added Mass (kg)
M_r	=	Resultant mass (kg)
PA	=	Atmospheric pressure at the ocean's surface
P_D	=	Dynamic pressure
r	=	Displacement vector of cylinder
Re	=	Reynold's number
V	=	Velocity (m/sec)
W	=	Weight (kg)
W_{eff}	=	Effective Weight (takes buoyancy into account) (kg)
x_{cg-cb}	=	Horizontal distance from cg to cb (m)
z_{cg-cb}	=	Vertical distance from cg to cb (m)

ACKNOWLEDGMENT

The author gratefully acknowledges the financial support of the Naval Oceanographic Office, Code N532. This work was performed under Contract N6230698OB80001. I would like to acknowledge and thank Prof. Peter Chu of the Oceanography Department and Adjunct Professor Steve Haeger of the Institute of Joint Warfare Analysis, Naval Postgraduate School, for their guidance in conducting this study and preparing this work. I would also like to thank Mr. Rob Bourke, Mr. Ed Nath and the staff of the Naval Postgraduate School Secure Computing and Simulation Laboratory for their expertise and patient assistance.

My utmost gratitude and respect go to my husband, Tim. His unflagging support and assistance of this effort has made it both possible and worthwhile. I would also like to credit my children, Diana and Masao, whose smiles at the end of the day renewed my perspective.

I. INTRODUCTION

In minesweeping, success often hinges on knowing as much as possible about the mines that have been placed and the effects the environment has had on that placement. Since bottom mines cannot be searched for visually, and are often difficult to locate with conventional sonar, an estimate of the area or height of the mine protruding from the sediment, or the burial depth if completely covered, is crucial information for the planning and execution of mine clearance operations. Determining the likely mine burial depth requires numerical models of the burial process and knowledge of the environment, including sediment properties, waves, tides, and water depth.

Ocean deployed mines currently used by the U.S. and other nations fall into three general categories: bottom mines, moored mines and drifting mines. Bottom mines rest on the ocean floor and are generally deployed in littoral regions. Common placements for bottom mines include shipping channels, harbors, anchorages, rivers and estuaries. Bottom mines are deployed in one of three ways: aircraft, surface ship or submarine. Although mines are designed to be deployed by a specific platform, most mines can be deployed by surface ship with little modification (NMWEA, 1991).

Several numerical models have been developed to simulate the mine burial process, and constitute the only viable means for determining a predicted burial depth, which is critical information when clearing an area of mines. The Impact Burial (IB) model was developed to determine the depth at which the mine comes to rest in the sediment upon impact. Originally created by Arnone and Bowen (1980) at the Naval Coastal Systems Center in Panama City, Florida, the IB model was designed to create a

two-dimensional time history of a cylindrical mine as it falls through air, water, and sediment phases (Fig. 1). The burial depth of the mine in the marine sediment is then calculated from the mine's velocity on contact with the sediment and the sediment characteristics.

Several revisions and changes have been made to the model to refine the physics and allow for more realistic geometry and more extensive input from the user. Most notable are the changes made by Satkowiak (1987) and Hurst (1991). Other revisions involved translating to newer computer languages and simplifying the data entry process.

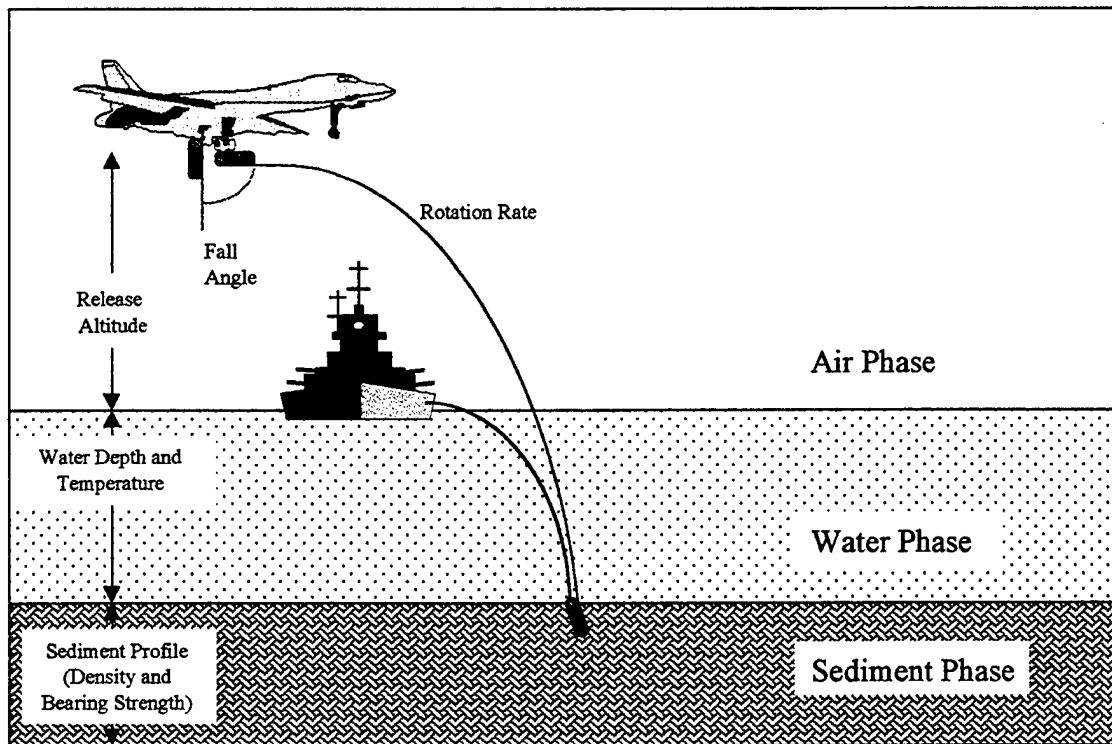

Figure 1. The trajectory of a cylindrical mine as it falls through three phases: air, water and sediment. Labels on the right are parameters used by the model to calculate velocity, attitude, and burial depth of the cylinder.

Currently, the model allows the user to input nearly any value for each environmental parameter. Many of these parameters are rarely if ever known by the technician, and their inclusion makes it very difficult for the field user to get an accurate solution. With this in mind, a sensitivity test was designed and executed with the objective of simplifying the input parameters without compromising the accuracy of the model's output. By determining which can be eliminated or simplified without sacrificing accuracy, a complex model may be made more manageable for the customer. Several parameters were found to lend themselves well to simplification, while others had so little effect on the outcome that the default value is sufficient. Some parameters, however, have such a large influence on the final burial depth and are known with such poor precision that a method for more accurate field measurements should be investigated.

II. DYNAMICAL ANALYSIS OF A CYLINDRICAL MINE

A. GEOMETRY OF A CYLINDRICAL MINE

As a cylinder falls through a fluid medium it has a varying angle with respect to the vertical called its attitude, Φ (Fig. 2). The attitude of the cylinder determines the area of the cylinder that is perpendicular to the horizontal, called the projected area, A_h . As the attitude varies with time, the projected area also changes, as do the magnitudes of the vertical and horizontal forces acting on the cylinder.

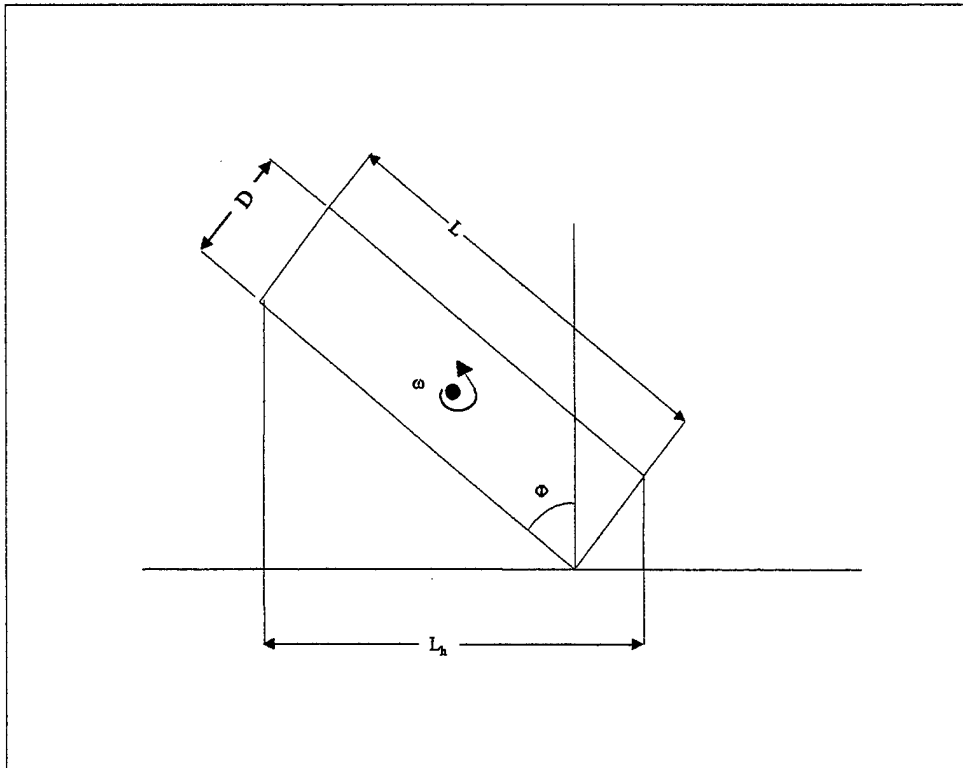

Figure 2. Horizontal length, L_h , as a function of cylinder diameter and length, D and L , and attitude Φ . Rotation rate, ω , determines the attitude at a given time.

B. ATTITUDE OF A CYLINDRICAL MINE

All forces and cavity calculations are affected by the attitude of the cylinder, Φ . Forces are broken down into those that act parallel to the axis of the cylinder, axial forces, and those that are perpendicular to the axis, called cross forces. If required, these force values can then be geometrically translated into horizontal and vertical forces.

If the mass is uniformly distributed within a mine the center of gravity, cg, and the center of buoyancy, cb, are the same. If they differ, the moments about the center of buoyancy which result from forces in the horizontal and vertical directions are denoted as x_{cg-cb} and z_{cg-cb} . These values are used along with the weight, W , and velocity, V , of the mine and the kinematic viscosity and density of the fluid, Λ_v and ρ to compute steady state attitude Φ^* for a specific time increment (Arnone and Bowen, 1980)

$$\Phi^* = \left\{ \frac{\left[W - (\Lambda_1 \rho V (\cos \Phi)^2) \right] (z_{cg-cb})}{\left[W - (\Lambda_2 \rho V (\sin \Phi)^2) \right] (x_{cg-cb})} \right\} \quad (1)$$

C. ADDED MASS

Following a mine's deployment by aircraft, it penetrates the air, water, and sediment. The periods during which the mine falls through each of these media are called the air phase, water phase, and sediment phase. A solid body moving in a fluid originally at rest behaves like a body of increased inertia (Mises, 1959), depicted using the term added mass, M_{added} . The summation of the added mass and the mass in air, M_a , is called the resultant mass, M_r :

$$M_r = M_a + M_{added} \quad (2)$$

Where M_a is the weight in air ($M_a=W/g$), W is the weight of the cylinder and g is the gravitational acceleration.

The added mass, also called apparent mass, is a function of the shape of the object. It is computed using inertial coefficients that account for the flow processes about the object and the cylinder volume, B . For a cylindrical object two inertial coefficients are required, κ_1 and κ_2 , to account for axial flow and cross flow:

$$M_a = \kappa_1 \rho B \cos \Phi + \kappa_2 \rho B \sin \Phi \quad (3)$$

D. PROJECTED AREA

The projected area of a cylindrical mine varies as a function of the cylinder's attitude (Fig. 3). The horizontal and vertical lengths of a cylindrical mine, L_h and L_v , are computed by:

$$\begin{aligned} L_h &= L \sin \Phi + D \cos \Phi \\ L_v &= L \cos \Phi + D \sin \Phi \end{aligned} \quad (4)$$

The projected area for a horizontal cylindrical mine, A_h where $\Phi = 90^\circ$, or for a vertical mine, A_v where $\Phi = 0^\circ$, is defined as:

$$\begin{aligned} A_h &= LD \\ A_v &= B D^2/4 \end{aligned}$$

Thus, the projected area for a cylindrical mine with an attitude of Φ is computed by:

$$A = A_h \sin^2 \Phi + A_v \cos^2 \Phi \quad (5)$$

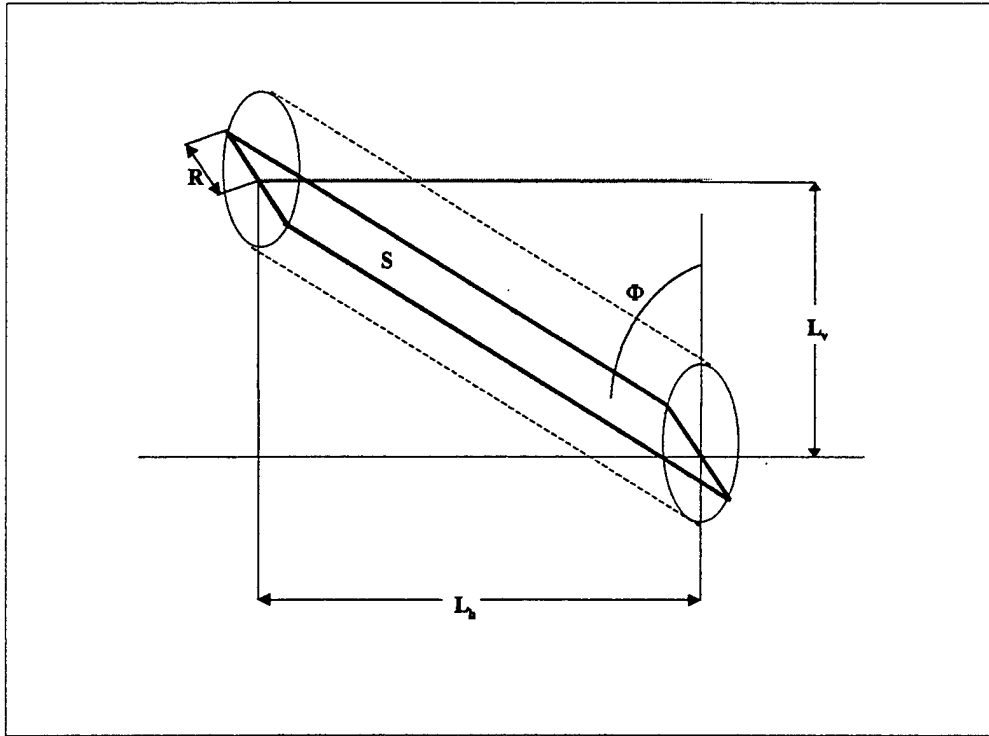

Figure 3. Parameters used to compute projected lengths and projected area.

E. DRAG COEFFICIENT

Drag on a circular cylinder is proportional to the sum of forces acting both vertically and horizontally. The drag coefficient used to calculate the total drag must therefore take each force into account. The drag coefficient, C_D , is derived from the Reynolds number and the shape and dimensions of the object. For a cylinder, the method used depends on whether it is a right circular cylinder or if it has a taper or rounded nose. Both cases are described below.

The drag force on a cylinder is computed using the projected area of the immersed body, A_h , the velocity of the object, V , and the drag coefficient (Schlichting, 1979):

$$F_d = 0.5 C_D \Delta V^2 A \quad (6)$$

1. Drag Coefficient for a Circular Cylindrical Mine

In order to determine C_D we must first determine the Reynolds number for the object. A smooth right circular cylinder has a Reynolds number of less than 10^5 , indicating that laminar flow is dominant. The Reynolds number is calculated separately for axial and cross flow using the corresponding velocity, V , and the kinematic viscosity of the fluid, Λ_v :

$$Re = VD / \Lambda_v \quad (7)$$

The drag coefficient for the skin friction, C_F , is computed using the Reynolds number (Mises, 1959), which is then used to calculate the base drag coefficient, C^*_D :

$$C_F = 1.328 (Re)^{-0.5} \quad (8)$$

$$C^*_D = 0.33D/L + C_f [(3L/D) + 3(D/L)^{0.5}] \quad (9)$$

Further modification accounts for the projected surface area, which will always be less than or equal to the projected area of a horizontal cylinder. This is done by applying a ratio of A_h and the standard wetted area of a cylinder (equal to projected area of a horizontal cylinder), A_w . A generic coefficient of 1.1 is also applied to account for surface imperfections on the cylinder (Arnone and Bowen, 1980):

$$C_D = C_D * 1.1 (A_h/A_w) \quad (10)$$

2. Drag Coefficient for a Tapered or Round-Nosed Cylindrical Mine

If the circular cylinder has a rounded nose or is tapered slightly, turbulent flow will be present and the Reynolds number is computed by the Prandel-Schlichting (Schlichting, 1979) skin-friction coefficient:

$$C_F = 0.455/(\log Re)^{2.58} \quad (11)$$

The overall drag coefficient is calculated using both the diameter of the base, D_B , and the maximum diameter, D (Arnone and Bowen, 1980):

$$\begin{aligned} C_D' &= C_F (A_w/A_b) * [1 + (60(L/D)^{-3}) + 0.0025(L/D)] \\ C_D &= C_D' + (0.029 (D_B/D)^3 (C_D')^{-0.5}) \end{aligned} \quad (12)$$

III. MOMENTUM BALANCE OF A CYLINDRICAL MINE IN AIR AND WATER

A. EQUATION OF MOTION

The movement of a mine in the air and the water is depicted by the momentum equation:

$$M_r dV/dt = F_{w,a} + F_b + F_d \quad (13)$$

Where V is the velocity of the mine, $F_{w,a}$ is the force due to the air weight of the mine, F_b is buoyancy force and F_d is drag force from equation (6).

Buoyancy force is the upward force exerted upon a mine in the gravitational field by virtue of the density difference between the mine and that of the surrounding fluid. We use the Cartesian coordinate system (x, y, z) with the z -axis in the vertical direction, and use the unit vector k along the z -axis (pointing downward). The buoyancy force is then computed using the density value for air or water, ρ , and the volume of the mine, B :

$$F_b = -\rho g B k \quad (14)$$

B. MINE ENTRY INTO WATER

A cylindrical mine penetrating into water passes through two distinct regimes. The first regime is the cavity regime. As the mine pushes into the air-water interface, it creates a cavity that consists of a combination of air and water particles. The ratio of air to water in the cavity decreases until the fluid properties become that of water only, at which time the mine is in the fully wetted regime. A temporal variation of the mine's vertical position can be calculated using a method similar to that depicted in the previous section.

1. Cavity Regime

Upon impacting the water, the cylindrical mine enters the cavity regime of the water phase. The fluid in the cavity is actually a combination of air and water, and the properties change continuously with the mine's downward vertical motion.

The most critical properties of a fluid when predicting the movement of an object within the fluid are density and kinematic viscosity. In the cavity regime, the fluid density is a gradient from that of air, 1.29 kg/m^3 , to that of water, 1025 kg/m^3 . In order to describe the ratio of water volume to total cavity volume we use the term void ratio, f_D . This value is used to determine the actual density of the fluid in the cavity. Although it is difficult to determine f_D precisely, the gradient is assumed to be linear. When the mine is fully in the air the void ratio is zero, and when fully in water it is one. The void ratio is modeled based on the assumption that the ratio of water volume to air volume in the cavity increases with an increase in the ratio of hydrostatic pressure to dynamic pressure. When the pressure generated by the dynamic loading of the cylindrical mine as it impacts the water, called dynamic pressure, is balanced by the hydrostatic pressure of the water, P_s , the cavity collapses and the mine is considered fully wetted (Arnone and Bowen, 1980). The dynamic pressure, P_D , is the summation of the atmospheric pressure at the ocean surface (assumed constant) and the pressure caused by the mine movement:

$$P_D = P_a + \frac{1}{2} \Delta_{TFM} V^2 \quad (15)$$

Where Δ_{TFM} is the two-phase mixture density in the cavity.

Arnone and Bowen (1980) further demonstrate this relationship by stating that the void ratio equals the square root of the pressure ratio:

$$f_D = \sqrt{P_D/P_s} \quad (16)$$

The two-phase mixture density, Δ_{TFM} , and kinematic viscosity, Λ_{TFM} , in the cavity are computed at each time step. The fluid properties of density, ρ_a and ρ_w , and kinematic viscosity, Λ_a and Λ_w , for air and water are also required:

$$\Delta_{TFM} = \Delta_a (1 - f_0) + f_0 \Delta_w \quad (17)$$

$$\Lambda_{TFM} = [(\Delta_a \Lambda_a) (\Delta_w \Lambda_w)] / [(1 - f_0) \Delta_a \Lambda_a + f_0 \Delta_w \Lambda_w] \quad (18)$$

At the each time step, the hydrostatic and dynamic pressures are calculated from the velocity of the cylindrical mine, and the void ratio is determined. When the hydrostatic and dynamic pressures are equal, the void ratio takes the value of 1 and the cavity collapses. The mine is then considered to be in the fully wetted regime. At this point the velocity of the mine is called the exit cavity velocity. If the actual water depth is less than the depth at which the cavity collapses, the mine impacts the sediment prior to exiting the cavity and there is no fully wetted regime.

2. Fully Wetted Regime

The trajectory of a mine in the fully wetted regime is similar to that in the air except the properties of the fluid have changed. The exit cavity velocity is used as an initial condition for the mine momentum equation (13), used to determine the mine trajectory. When the vertical distance of the mine traveling in the water equals the water depth, the mine velocity is called the bottom impact velocity, which is the initial condition for determining the mine burial depth in the sediment.

C. MINE BURIAL IN SEDIMENT

1. Viscosity and Shear Strength

Penetration of the cylindrical mine into the bottom sediment depends primarily on the attitude and velocity of the mine upon impact, as well as the sediment properties of density and shear strength. Initial impact of the cylindrical mine into the sediment

creates a cavity in which the fluid properties of water and sediment are interacting. To determine the mine burial depth in the sediment, one must determine the void ratio and the two-phase density and kinematic viscosity. A procedure similar to that depicted in the previous section can be used to determine these parameters. However, the computation of the two-phase kinematic viscosity for the water-sediment cavity differs a bit from that of the air-water cavity. The kinematic viscosity of the sediment, Λ_s , is not a pure constant, but rather is equal to the water viscosity, Λ_w , plus that resulting from the shear stress of the sediment:

$$\Lambda_s = \Lambda_w + S_u / (\Delta_s dV/dz) \quad (19)$$

Where Δ_s is the density of the sediment and S_u is the shear strength.

2. Mine Burial Dynamics

The vertical momentum balance of a mine in the sediment phase is given by:

$$M_r dV/dt = F_{w,a} + F_b + F_d + F_c + F_s \quad (20)$$

where F_b is the buoyancy force in the sediment, F_c is the compressive force, and F_s is the shear force. F_c and F_s are additional forces (different from air and water phases) exerted on the mine by the sediment. They are proportional to shear strength of the sediment and the projected area of the mine. If the mine is a right circular cylinder, the compressive force is twice the shear force:

$$\begin{aligned} F_c &= 2 F_s \\ F_s &= S_u A \end{aligned} \quad (21)$$

The mine burial depth is predicted by integrating (20) with respect to time until the mine velocity becomes zero. Accurate values for sediment properties are essential to the accuracy of this process. Shear strength and density have a strong impact on the computation of all forces as well as buoyancy weight and added mass.

IV. MINE IMPACT BURIAL PREDICTION MODEL

A. DEVELOPMENT HISTORY

Based on the fluid dynamics of a cylindrical mine, Arnone and Bowen (1980) developed a mine impact burial prediction model called the Impact Burial Prediction (IB) Model. The basic model created a two-dimensional free-fall history of a right circular cylinder as it fell through air, water and sediment phases and calculated the burial depth of the mine after it came to rest in the sediment. The initial model had a number of shortcomings, particularly when handling soft or hard sediments or certain environmental conditions. It also handled the water-sediment cavity regime poorly.

Satkowiak (1987) modified the IB model, including:

- Corrected reference flow used in drag calculations
- Corrected added mass term equation
- Rewrote equations for sediment-cavity regime
- Allowing for drag due to cylinder's nose
- Allowing for rounded noses
- Inclusion of water temperature
- Inclusion of retarding forces in semi-solid sediment

The IB model was extensively revised by Hurst (1991). Equations for forces acting on the mine were redefined and equations to simulate rotational movement of the mine were added. Five primary areas were addressed and refined:

- Calculation of fluid drag
- Calculation of forces at air-water interface
- Calculation of forces upon impact with the sediment
- Allowing for rotational movement of mine as it falls
- Allowing for multilayered sediments (formerly only the deepest point was considered)

Also added in 1991 was the ability of the model to calculate fall angle dynamically, as it would in reality.

In 1993, Mulhearn's formulation for sediment bearing strength (1993), which takes sediment shear strength as well as the object's mass and geometry into account, was added to the IB model. The model was also modified at this time to allow for displaced centers of mass.

Currently, the twenty-sixth edition of the IB model is available in ANSI C format. The model features interactive data input with the user being prompted at every step. No user manual is required, and none exists at this time.

B. IB MODEL INPUT PARAMETERS

The IB model has a variety of parameters that must be entered by the user prior to running the model. Several of these parameters are unknowns, even to the mine sweepers, and others are easily determined based on intelligence and published charts or atlases.

One possible unknown parameter that is required is mine type. If the specific type of mine is known, the user enters the mine's characteristics of air weight, water weight, length, maximum diameter, taper length, base diameter, and center of mass offset distance from the published mine lists. If unknown, an educated guess must be made and a profile selected from those available in the model (Table 1). Most of the mine profiles available in the model, and most mines used today, are right cylinders with a center of mass in the geometric center of the mine. The model also has the capability to handle tapered mines and offset centers of mass. Both the weight and geometry of the mine have a large effect on the model's output, so care should be taken in selecting the mine type (Fig. 4).

Mine Name	Mine Case Number	Mass (kg)	Wet Mass (kg)	Length (m)	Max Diameter (m)	Taper Length (m)	Base Diameter (m ²)
Mine A	1	612	354	1.524	0.48	0	0.48
Mine B	2	227	170	1.676	0.292	0.396	0.076
Mine B-1	3	227	179	1.981	0.292	0.396	0.076
Mine B mod 0	4	499	181	1.767	0.47	0	0.47
Mine C	5	862	408	2.134	0.559	0	0.559
Mine A mod 1	6	442	220	1.524	0.48	0	0.48
PSI Mine	7	515	223	1.481	0.48	0	0.48
Korean Mine	8	538	251	1.49	0.475	0	0.475
Bowen Mine	9	964	413	2.316	0.597	0	0.597
NZ Dummy Mine	10	457	263	1.219	0.445	0	0.445
US Penetrometer	11	3.36	1.93	0.3048	0.0762	0	0.0762

Table 1: Parameters for mines that are available for selection in the model. Center of mass offset difference can also be specified (in meters) but is 0 for all selections available in the IB model.

The initial orientation of the mine can be set between 0° and 90° , with 0° being a vertical initial orientation and 90° being horizontal. This parameter may be based on the knowledge of how the mines were laid, but if unknown the default of 90° will yield the minimum burial depth. Another unknown value is the rotation rate, the constant rate a mine would rotate in degrees per second. Because rotation rate is known only in theoretical cases, the default has been set at zero.

If dropped vertically with no initial rotation rate, the mine will still tend to acquire a horizontal velocity component as it falls through the air and water phases. This results in the mine impacting the sediment at a random angle, significantly altering the actual burial depth. Satkowiak (1988) suggested that since the attitude of the mine upon impact with the sediment cannot possibly be known, even for controlled tests, the model should be used mainly to determine the maximum and minimum limits of the burial depth. Since 0° initial orientation provides the shallowest burial and 90° the deepest, the limits can be easily determined and the range of burial depth used with confidence.

C. AIR AND WATER PHASES

As the mine passes through the air and water phases, all forces acting upon it are calculated and summed. The acceleration is then calculated and integrated to provide the velocity of the mine as it enters into the next phase. The calculations for the air and water phases are similar, and for the most part are handled by a generic fluid subroutine. The first thing computed at each time step by the model is the effective axial and cross masses in air, cross and axial velocity, and the distance from the bottom of the mine to the center of mass and center of gravity for the current attitude of the mine. These values are then used to calculate the drag coefficients, drag force and torque on the mine.

Finally, the velocities are translated to x and z movement (in the Cartesian coordinate system) and Φ is recomputed to represent Φ^* , the steady state attitude at the end of the time increment. All values are calculated for a time increment of 0.01 seconds, and the values are printed to the screen in increments of 0.5 seconds.

The interface between each phase has a cavity regime where the nose of the mine is in a cavity that is actually a mixture of the two phases. The composition of the mixture changes rapidly as the mine pushes through the cavity. Depth of the cavity is calculated from the previous time step's values for attitude and depth of mine. The cavity exists until dynamic pressure equals hydrostatic pressure, at which point the cavity collapses.

D. SEDIMENT PHASE

The physical properties of the sediment used by the model are the depth, density and shear strength of each layer. This information may be available for some areas, but no database currently exists that contains sediment profiles including shear strength. This value is independent of density in saturated sediment and is difficult to measure, especially for soft sediments where a sample profile is extremely difficult to obtain. There are three sediment profiles available in the model that represent hard, medium and soft sediment types. All mines and all initial conditions produce complete burial in the soft sediment case. The most variance in burial depth comes from the medium-density sediment profile, and for this reason it was used in this sensitivity study unless otherwise noted.

The main contributions on the slowing of the mine as it impacts the sediment, according to Hurst, are bearing strength of the sediment (70%), hydrodynamic drag of the sediment (25%), and buoyancy in the sediment (5%).

1. Bearing Strength

In the original IB model, bearing strength was assumed to be the undrained shear strength times ten. It was soon determined that this simple assumption caused the burial depth to be consistently underestimated. By using a method devised by Mulhearn (1993) for calculating the bearing strength that incorporates the mine dimensions and the impact velocity, a more accurate result is obtained. Mulhearn bearing strength, BS_M , is calculated using sediment shear strength, S_u , and the rate of loading factor, rlf:

$$\begin{aligned} \text{rlf} &= (0.5 \text{ (mine impact velocity) / } D)^{0.15} \\ BS_M &= 5.14 S_u (1 + D / (5.14L_h)) (1 + 0.4z / D) (\text{rlf}) \end{aligned} \quad (22)$$

Where L_h is the horizontal projection of mine, D is the mine's diameter and z the depth from the mine's lower surface to the water-sediment interface.

In the IB model, this formulation can be toggled on or off by the user. Best agreement between measured and modeled burial depth was found when this formulation was used and shear strength was assumed to be constant for depths greater than 0.55 meters. The correct formulation for the rate of loading factor is still uncertain, however.

2. Hydrodynamic Drag in Sediment

Hydrodynamic drag in the sediment is the force required to push the sediment aside. Assuming a low Reynold's number of 10^5 , accurate for a right circular cylinder, and using a standard cavitation correction of 0.55, a drag coefficient of 0.98 can be empirically derived. C_{DH} , the hydrodynamic drag coefficient, is then calculated for the vertical velocity, C_z , at each time increment:

$$C_{DH} = (0.98 * C_z^2) / 2 \quad (23)$$

C_{DH} and the calculated area in contact with the sediment are then used to calculate the force this drag has on the cylinder.

3. Buoyancy in Sediment

Buoyancy in the sediment is due to the cavity formed as the nose pushes against the sediment and forms a cavity. Buoyancy is a result of hydrostatic pressure and is calculated using the density of the sediment ρ_s , density of the mine ρ_m , and the depth in the sediment h :

$$F_b = g h (\rho_s - \rho_m) \quad (24)$$

It is assumed that the hydrostatic forces work uniformly on the surface area of the leading edge of the mine that is in contact with the sediment. The total buoyancy force is then calculated using the surface area of the leading edge and the buoyancy coefficient above.

E. ENVIRONMENTAL PARAMETERS IN THE IB MODEL

The altitude from which the mine is released determines the velocity and attitude of the mine as it reaches the air-water interface. If a mine does not fall straight down but rather "tumbles" with a constant rate of rotation, simulated in the model by providing a rotation rate θ , the attitude of the mine upon reaching the water is impacted greatly by the release altitude. Although not accounted for in the model, this rotation rate may be caused or affected by wind.

In the water phase, this rotation rate is damped significantly. However, it still has a great effect on the angle the mine makes with the sediment upon impact. Currents may affect the rotation rate in the model, but again are not accounted for in the model. The water depth only has an effect on impact velocity if it is less than that required for the mine to reach terminal velocity, the velocity at which the deceleration due to frictional drag is equal to the acceleration from gravity. The velocity at which this equilibrium is reached is a function of the weight of the mine. Since mines are laid in shipping channels almost exclusively, one may assume that water depths in excess of that required for a

mine to reach terminal velocity are the norm. Water temperature has an effect on the viscosity of seawater, and hence increases the drag of the seawater on the mine.

Properties of the sediment are represented by density and shear strength profiles. Density of marine sediment tends to have a s-shaped profile with sharper gradients as density increases. Shear strength, the ability of the sediment to withstand pressure without deforming, also typically has a s-shaped profile and increases with distance from the water interface. The shear strength is related to the level of cohesion between the sediment particles. The density range of concern to the mine impact burial problem is 1375 to 1600 kg/m³. Factors contributing to shear strength are the type of material, water content, history of stress or disturbance and time since deposition (Noorany, 1985). Although both increase with distance from the interface, there is no clear correlation between shear strength and density. Figure 5 is a scatter plot of density and shear strength values for 62 sediment samples, all taken at the water-sediment interface. For this particular data set, the correlation is extremely weak. Shear strength at the water-sediment interface can be measured in situ with a vane penetrometer or other instrument.

A profile of shear strength such as is called for in the model must be measured from a core sample in the laboratory. This process is time consuming and expensive, and no database of shear strength values currently exists. The term bearing strength, as used in the IB model data ingest, refers to the undrained shear strength times 10. This value, however, is converted back to shear strength and used in the Mulhearn bearing strength equation.

Although not a parameter considered in the IB model, wave action has a direct effect on water depth and, therefore, on velocity of the mine as it reaches the sediment interface. This effect only becomes significant when the ratio of water depth to wave height is high, and only at very low release altitudes (Table 2).

	Wave Height		
Mean Water Depth	1 meter	2 meter	5 meter
5 meters	0.12	0.21	
13.7 meters	0.03	0.06	0.16
20 meters	0	0	0

Release altitude=1.5m

	Wave Height		
Mean Water Depth	1 meter	2 meter	5 meter
5 meters	0.02	0.05	
13.7 meters	0	0	0
20 meters	0	0	0

Release altitude=150m

Table 2. Effect of wave height on burial depth. Wave heights were set around a mean water depth and release altitude was selected to represent a ship or aircraft delivery. If released from 150 meters, wave height has little effect. If released from near the water surface, wave height upon release has a significant impact if the depth/wave height ration is high.

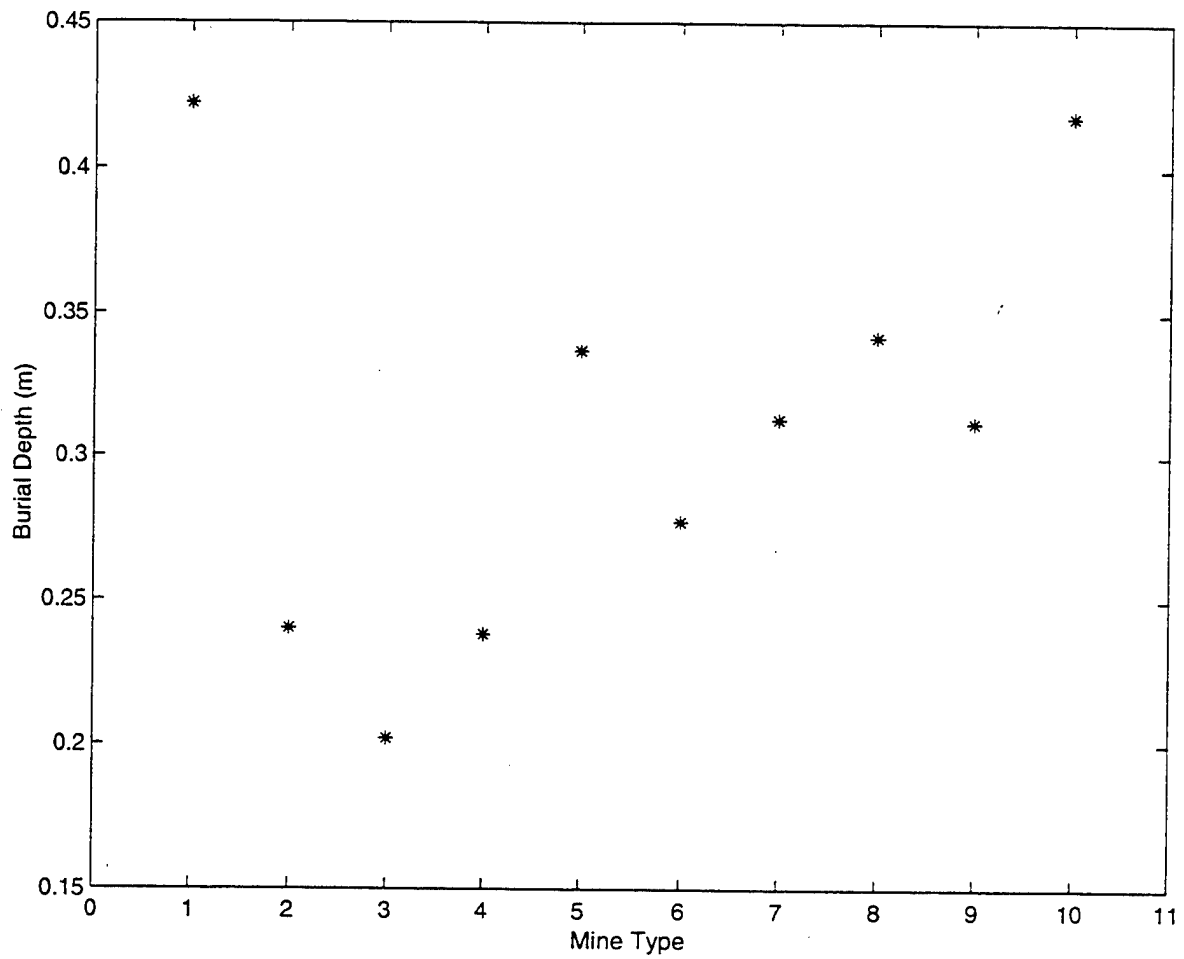

Figure 4. Sensitivity of IB predicted burial depth (m) to various mine types. Characteristics of mine types are in table 1.

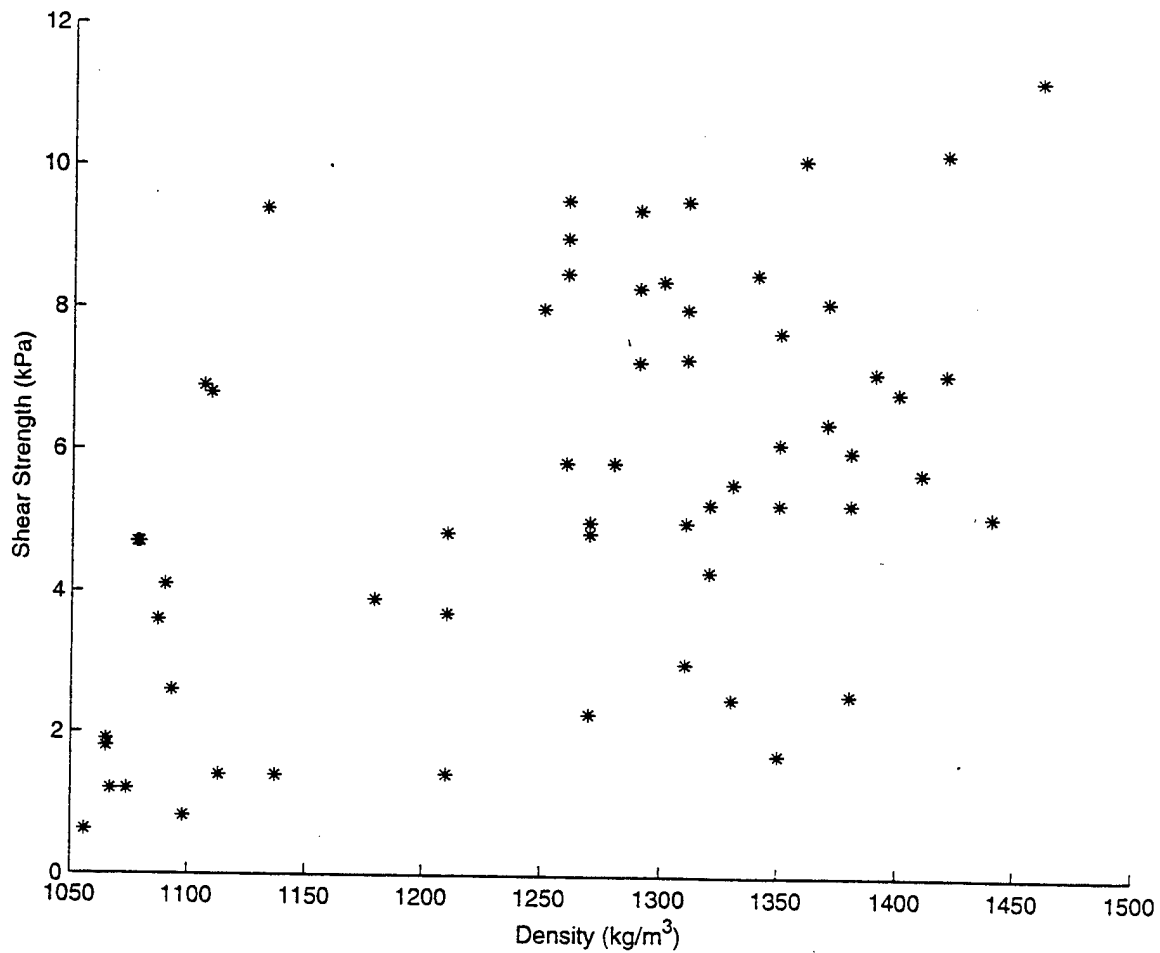

Figure 5. Scatter diagram of sixty-two pairs of density (kg/m^3) and shear strength (kPa) data. Shear strength values are most dependent on percentage of clay and time since deposition. Data obtained from Voelkner (1973) and Mulhearn (1993).

V. SENSITIVITY STUDY FOR THE CYLINDRICAL MINE

The purpose of this study is to ascertain which variables the model is most sensitive to and which can be simplified or eliminated in order to simplify its use. Since some variables are typically unknown by the user, it is important to determine which of these have the most impact on the model and which can be reduced to toggled values or default values without greatly impacting the accuracy of the model. The model was altered to allow most parameters to be set and a loop run of one variable at a time. The range of each variable was set to represent all possible conditions the model would be used under. It should be noted that wind and currents are not accounted for in this model. However, the only impact they would have would be on the attitude of the mine as it enters each phase. All runs were made with preset mine profile "Korean Mine", which has a dry weight of 538 kg, a wet weight of 251 kg, and a uniform diameter of .475 meters.

Since the model calculates burial depth and then geometrically calculates the height, volume and area protruding, these values are proportional. To confirm this, we created derivative plots of these values for one case and found the shapes of the curves to be very similar (Fig. 6). Burial depth is used to explain most of the sensitivity test, except where height protruding is more descriptive.

A. SENSITIVITY TO RELEASE MEDIUM PARAMETERS

Figure 7 demonstrates the variation of the release medium parameters of altitude, water depth and water temperature. Altitude, when varied from 0 to 1000 meters, has a small impact on burial depth (relative difference of 18%). When a more realistic upper limit of 300 meters for a mine laying aircraft is applied, the relative difference drops to

just 9%. Water depth has an effect on the burial depth only if less than the depth needed for a mine to reach terminal velocity, in this case 20 meters. At depths greater than this value, the mine reaches terminal velocity in the seawater and excess water depth has no effect on burial depth. At depths from 0 to 20 meters, the variance in burial depth depends on both altitude and water depth since the vertical velocity of the mine as it enters the water becomes pertinent (Fig. 8).

Water temperature was found to have no effect on the model's outcome. Although temperature variance does alter the density of water up to 3% and also affects the viscosity (Stanley, 1969), this effect is not significant enough to alter the burial depth value calculated by the model.

All cases discussed thus far assumed an initial angle of 90° with respect to the horizontal and with a rotation rate of zero. This produces a situation where the mine is heading directly downward throughout the entire simulation, resulting in the maximum burial depth. When this initial attitude is varied, the burial depth is affected greatly as outlined in Table 3.

	Altitude = 1.5 meters	Altitude = 150 meters
Fall Angle = 0°	0.977 m	2.405 m
Fall Angle = 90°	0.342 m	0.359 m

Table 3. Maximum and minimum burial values for a mine released from 1.5 or 150 meters. An initial fall angle and subsequent sediment impact angle of 0° indicates a perpendicular orientation and maximum burial depth. Fall angle of 90° indicates the mine is parallel to the sediment and yields a minimum burial depth.

B. SENSITIVITY TO SEDIMENT CHARACTERISTICS

As expected, sediment parameters are the most critical element in determining how deep the mine was buried when it came to rest. Sensitivity to the alteration of sediment density and shear strength was tested two ways. First, six sediment profiles were entered into the model and the resulting burial depth was examined (Fig. 9). These included three profiles from Sydney Harbor (Mulhearn, 1993) and three profiles available for selection in the IB model. The profiles included in the model are called simply “softsed”, “medsed”, and “hardsed” and do not clearly correspond to specific sediment types. Second, simplified cases of a single layer of sediment were used with constant density, varying shear strength and constant shear strength with varying density.

1. Sensitivity to Shear Strength and Density

Figure 10 illustrates the sensitivity of burial depth on density and shear strength. Here, a simple profile of just one layer was used and density and shear strength were varied separately. All other parameters were kept unchanged as default values. Plot (a) is the burial depth with shear strength held constant and varying density from 1000 to 2000 kg/m³. Shear strength of 1 kPa indicates extremely soft sediment, and density has a noticeable effect on burial depth of 37%. At the more common shear strength values of 5 to 15 kPa density has little effect, just 3.7%. Plot (b) illustrates the effect of varying shear strength while keeping density constant. Again, we see the greatest impact of density value on the model output at low shear strength values. As shear strength increases, so does the influence of varying density.

Tables 5 and 6 illustrate the effect on burial depth of simplifying the sediment profiles in two ways. Several methods for simplifying the sediment profile requirements were investigated, using the full profile case as a control. First, the density and shear

strength were held constant to 5 meters. The relative difference is under 26% for all profiles using this simplification. Next, a process of manufacturing sediment profiles using the density values measured at the water-sediment interface was derived and applied to the model. The profiles were assumed to consist of a constant value layer at the surface to a depth h_1 , a sharp gradient to h_2 , and then constant to a depth of 5 meters. The profiles were first applied to density only, holding shear strength constant, and then to both density and shear strength. Values for h_1 , h_2 , $\rho(h_2)$, and $\tau(h_2)$ were calculated by applying ρ_0 and τ_0 to polynomials derived from the data. The softsed and medsed profiles create the greatest differences from the control in all cases.

Interestingly, creating a simulated density profile and keeping the shear strength value constant had no effect on the burial depth result when compared to keeping both values constant for five meters. This serves to underscore the fact that it is the shear strength parameter that has the primary influence on burial depth, not the more easily measured density parameter.

2. Simulated Sediment Profiles

Several attempts were made to manufacture shear strength profiles from density and shear strength values measured at the interface. This was explored in order to determine if a viable method of simplifying the data entry for the sediment phase could be devised. One attempt consisted of applying a fitted polynomial to measured density and shear strength values to create a synthetic profile from only interface values. Values for the sediment profiles used in the study, calculated with the following equations, are listed in table 5.

Based on the density profiles in figure 9, we empirically derived curve-fitting equations to represent the density profile,

$$h_1 = -0.000061833 \cdot \rho_o + 0.01609$$

$$h_2 = -0.0015 \cdot \rho_o + 3.10$$

$$S_u(h_2) = [(2.2048 \cdot 10^{-5}) \rho_o^4] - (0.109 \rho^3) + 201.1381 \rho^2 [(1.6432 \cdot 10^5) \rho] + (5.0136 \cdot 10^7)$$

$$\rho(h_2) = \rho_o + 250$$

	Mossman Bay	Rose Bay	Off Woolwich
h_1 (m)	0.083	0.05	0.084
h_2 (m)	1.21	0.40	1.23
ρ_o (kg/m ³)	1260	1800	1250
$\rho(h_2)$	1510	2050	1500
τ_o (kPa)	9	13	8
$\tau(h_2)$	44	20.9	41

	softsed.sed	medsed.sed	hardsed.sed
h_1 (m)	0.093	0.084	0.081
h_2 (m)	1.45	1.23	1.15
ρ_o (kg/m ³)	1100	1250	1300
$\rho(h_2)$	1350	1500	1550
τ_o (kPa)	1	1.5	13
$\tau(h_2)$	3.5	10	20.9

Table 4. Values calculated using equations derived by fitting a polynomial to known density and shear strength profiles. The precision of this simplified method of depicting a sediment profile is demonstrated in table 5.

	Mossman Bay	Rose Bay	Off Woolwich
Full Profile	0.103 m	0.074 m	0.115 m
Measured ρ_o , S_u held constant to 5 meters	0.121 m	0.093 m	0.132 m
Relative Difference	15%	20%	13%
Density and Shear strength profiles created using measured ρ_o and S_{u0}	0.101 m	0.059 m	0.105 m
Relative Difference	2%	20%	1%

	softsed.sed	medsed.sed	hardsed.sed
Full Profile	0.523 m	0.342 m	0.084 m
Measured ρ_o , S_u held constant to 5 meters	0.683 m	0.463 m	0.094 m
Relative Difference	23%	26%	11%
Density and Shear strength profiles created using measured ρ_o and S_{u0}	0.300 m	0.179 m	0.085 m
Relative Difference	43%	48%	1%

Table 5. Predicted burial depths using manufactured profiles based on measured values at the interface.

Hayter (1986) discussed an equation originally derived by Krone (1963) for deriving shear strength, S_u , from density using empirically derived coefficients α and β :

$$S_u = \alpha \rho^\beta$$

Values for α and β must be calculated for each separate sediment type, after which the shear strength can simply be calculated using the coefficients. Figure 11 illustrates the impact of varying α and β on the model output, given a constant density. The profile was assumed to consist of one layer of homogenous material. As expected, as α and β increase, shear strength also increases and burial depth decreases. Figure 12 is a series of contour plots with varied values as the axes. The contours represent predicted burial depth values. Known shear strength values are marked on the corresponding density plot. For all cases, there is a unique value of the coefficients that will produce a shear strength value given a specific density. Please note that, while they are plotted here as one density value and one shear strength value per sediment type, a change in density would produce a corresponding change in shear strength that could be determined by use of the same two unique values of the α and β coefficients.

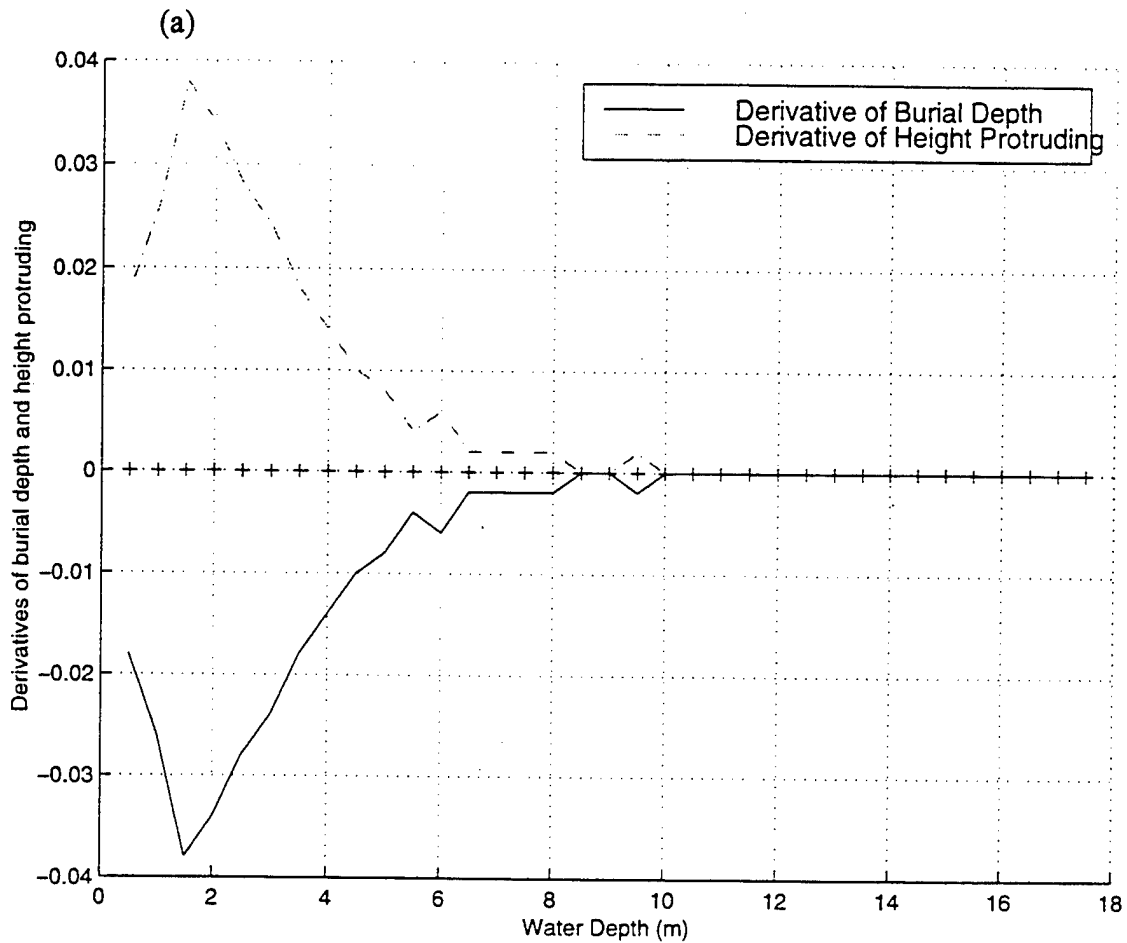

Figure 6. Derivative plot of all four output parameters from one IB model run. Notice the shape of each derivative plot is similar, confirming that one can be used to represent sensitivity levels of all output parameters. Burial depth was examined in the study for this paper, as it is the primary result obtained by the model.

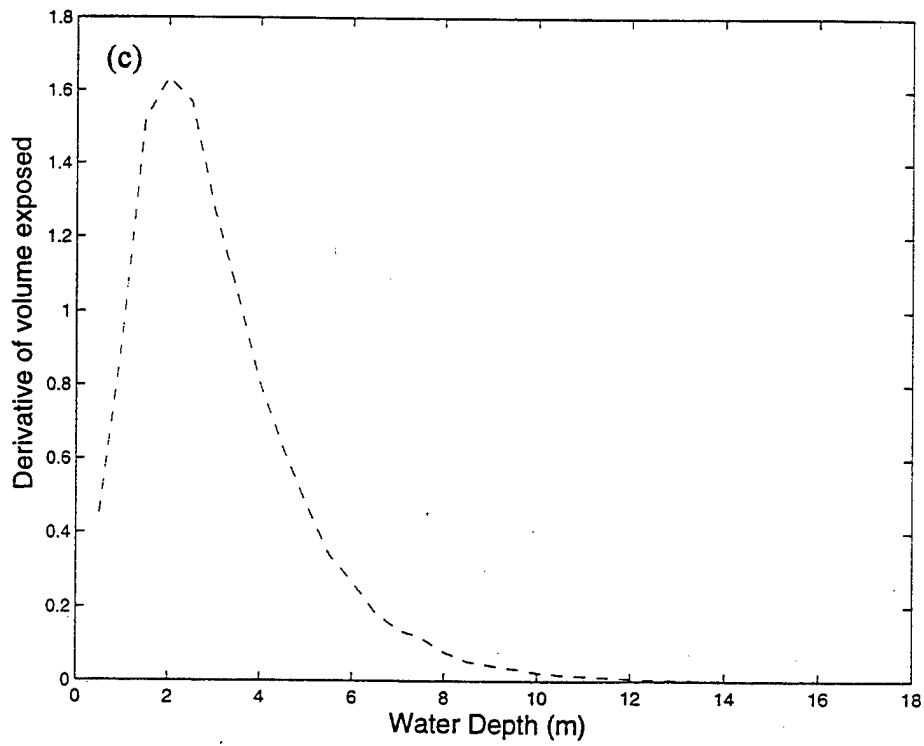
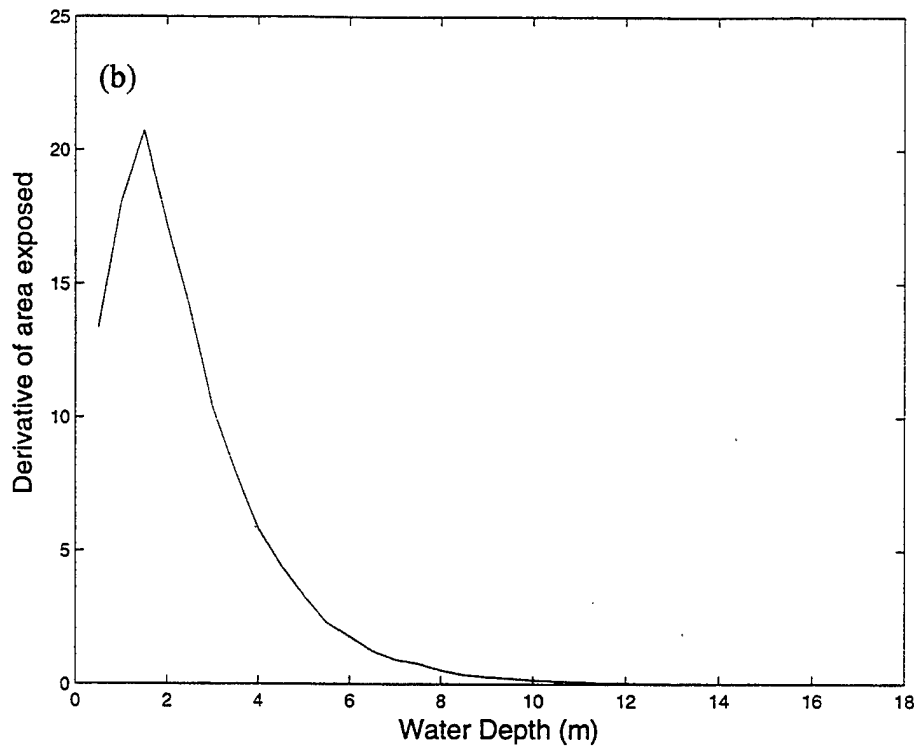

Figure 6. Continued from previous page.

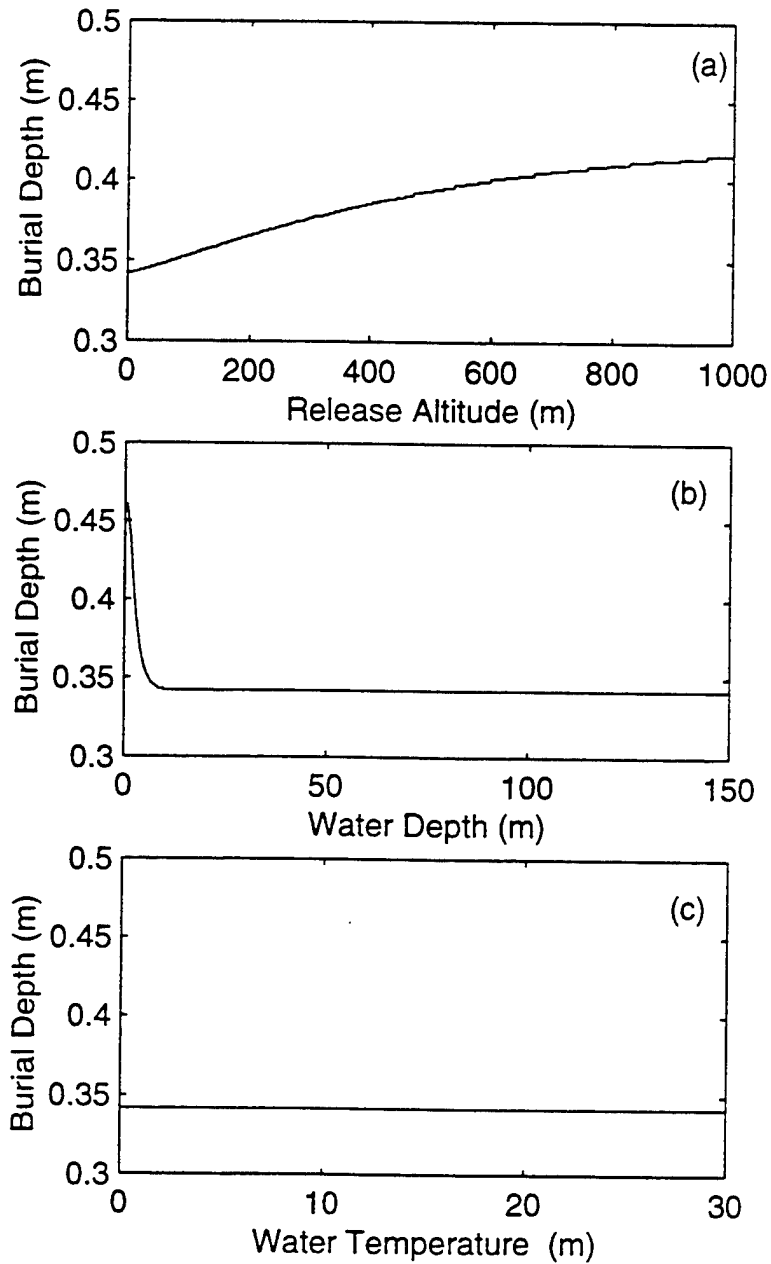

Figure 7. Effect of (a) release altitude (m), (b) water depth (m) and (c) water temperature ($^{\circ}\text{C}$) on predicted burial depth (m). Values were preliminarily chosen to represent all conditions under which the IB model may be used.

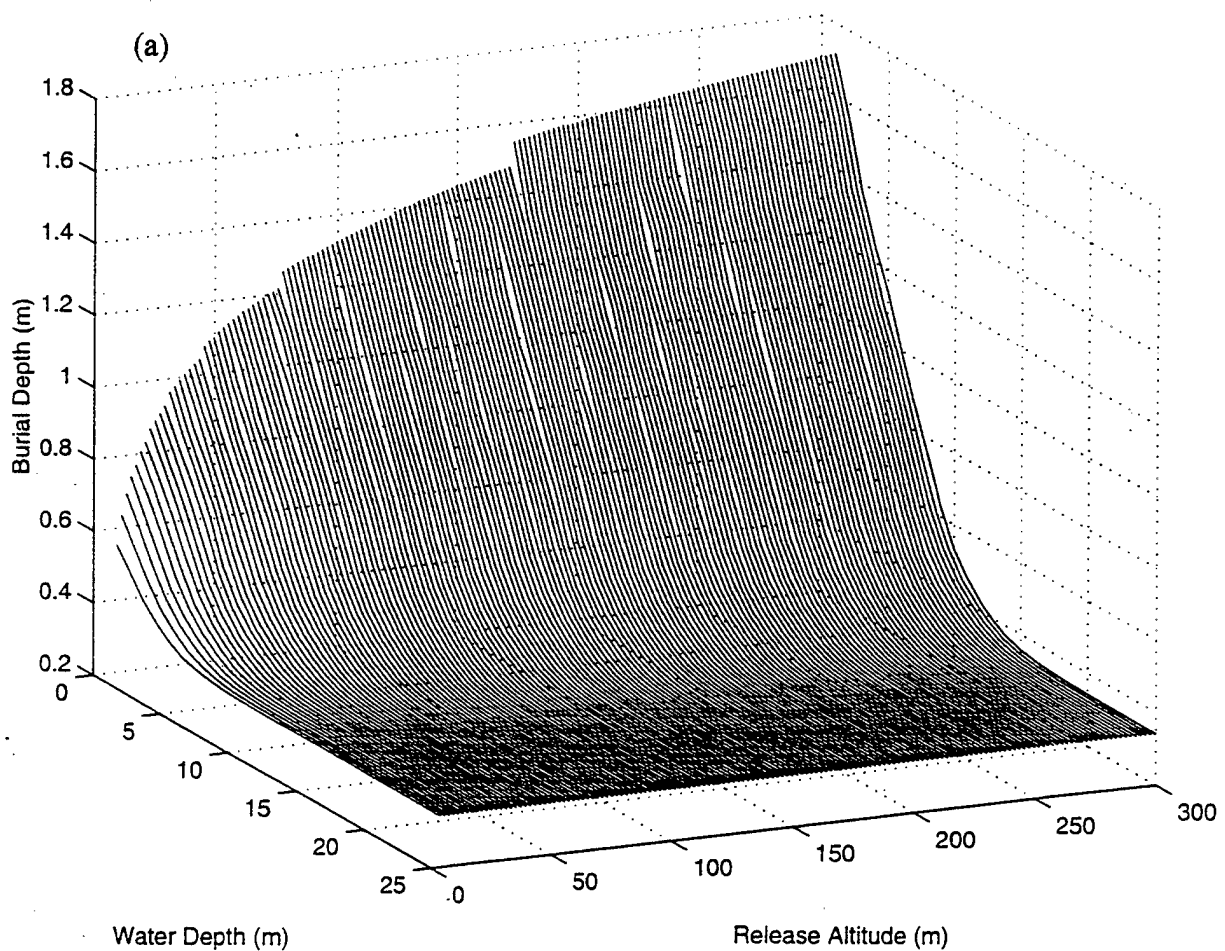

Figure 8. Three-dimensional plot of (a) burial depth (m) and (b) height protruding (m) as both release altitude (m) and water depth (m) are varied. Height protruded is illustrated here to clarify the levels at which these parameters become less influential in the IB prediction.

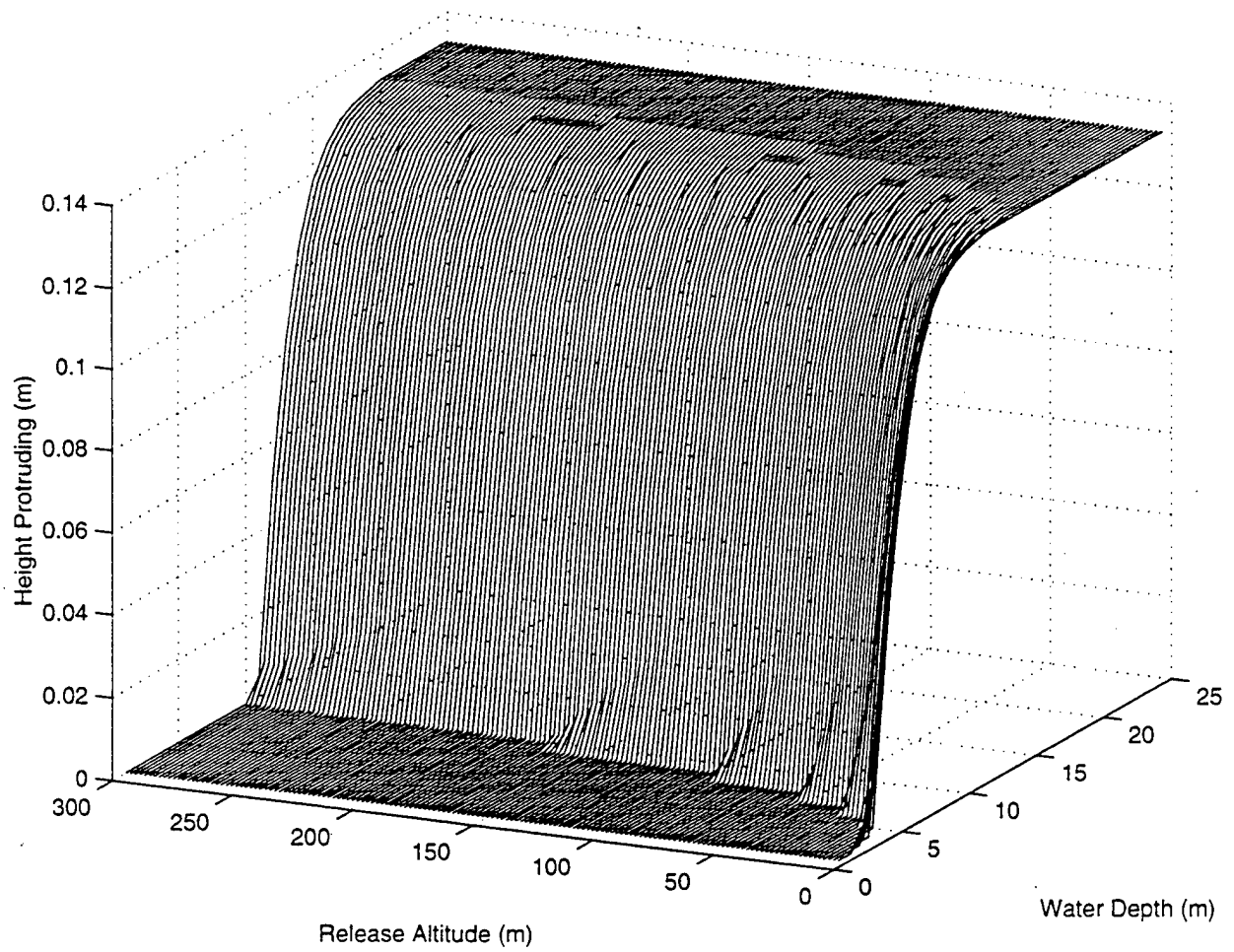

Figure 8. Continued from previous page.

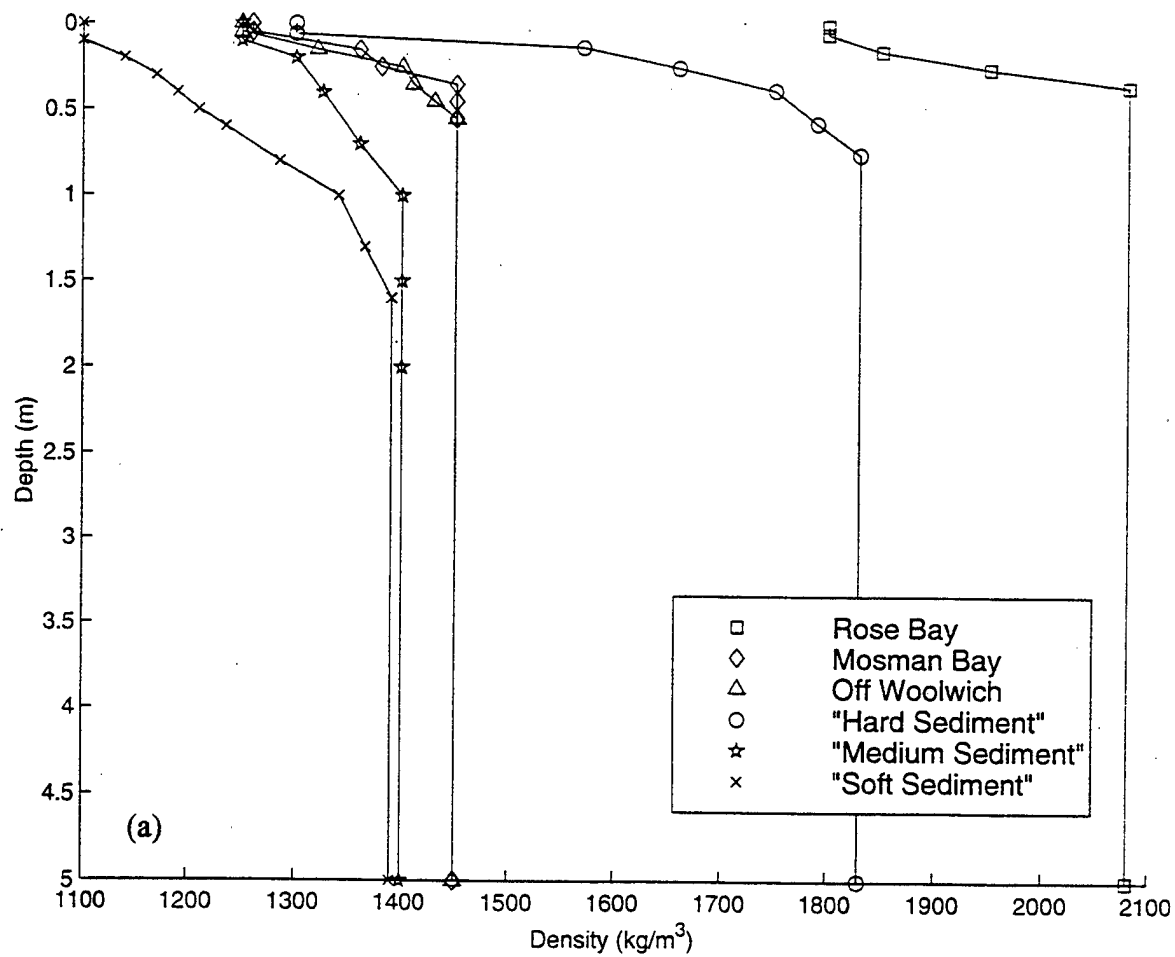

Figure 9. Sediment profiles of (a) density (kg/m^3) and (b) shear strength (kPa) used in the sensitivity study. Data obtained from Mulhearn (1993).

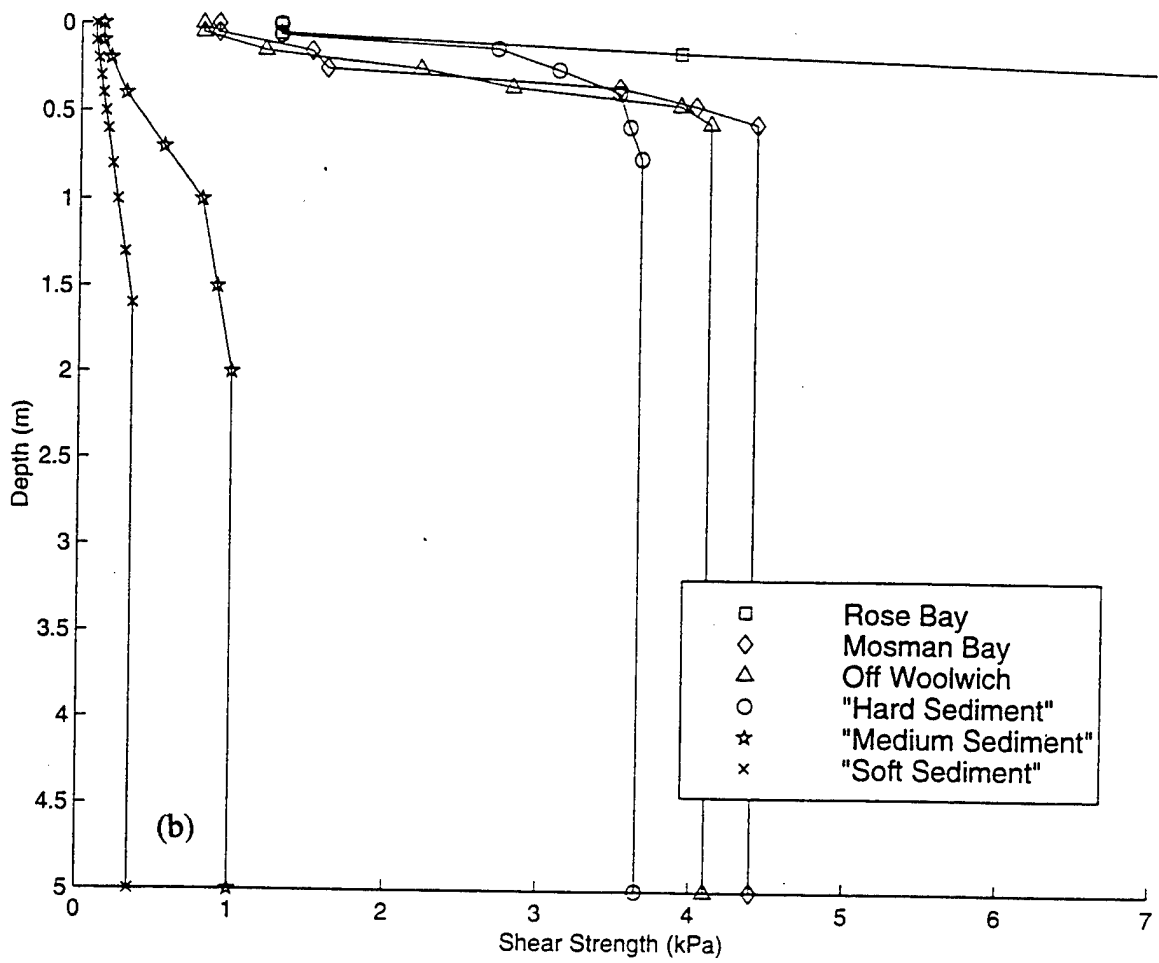

Figure 9. Continued from previous page.

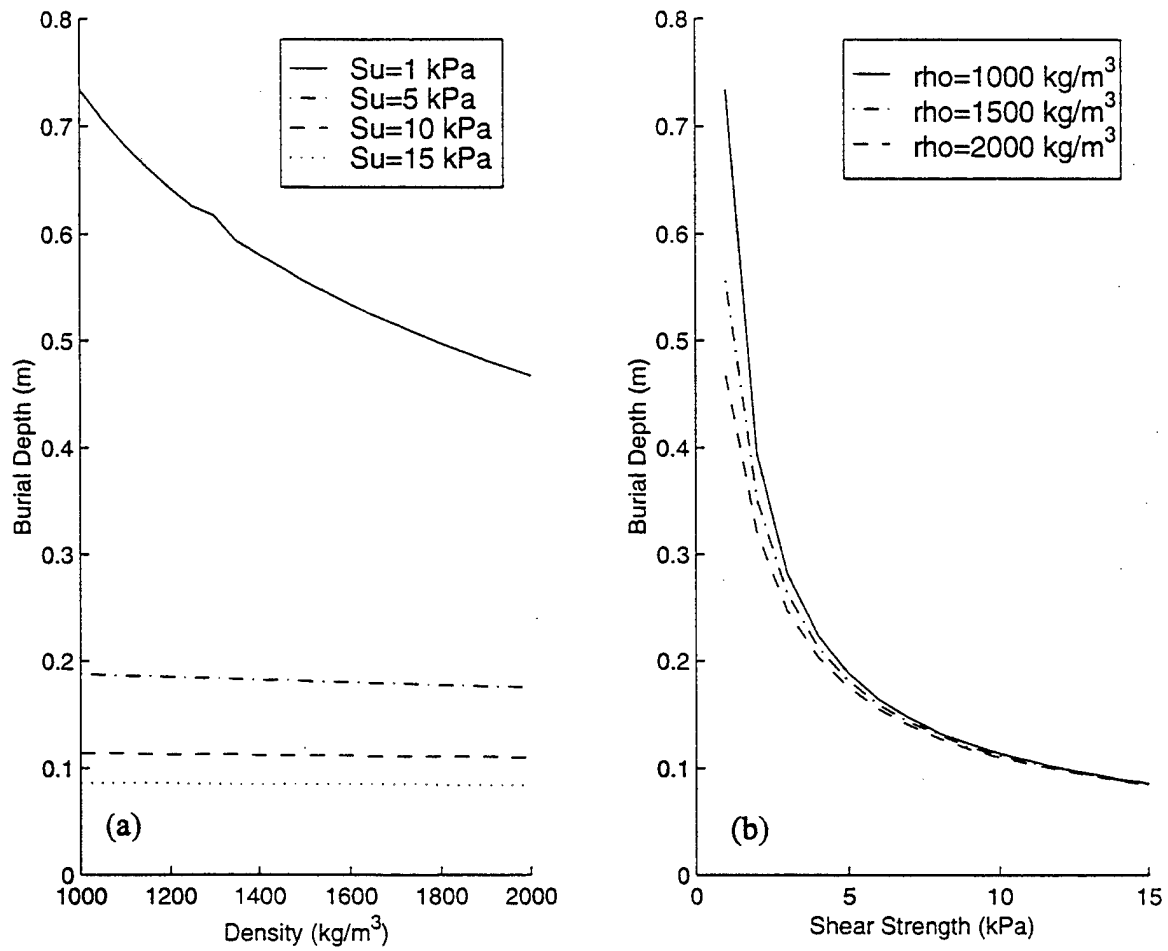

Figure 10. Effect of (a) density and (b) shear strength on burial depth. Density change only impacts the predicted burial depth in very soft sediments. As expected, shear strength has a dramatic impact on predicted burial depth.

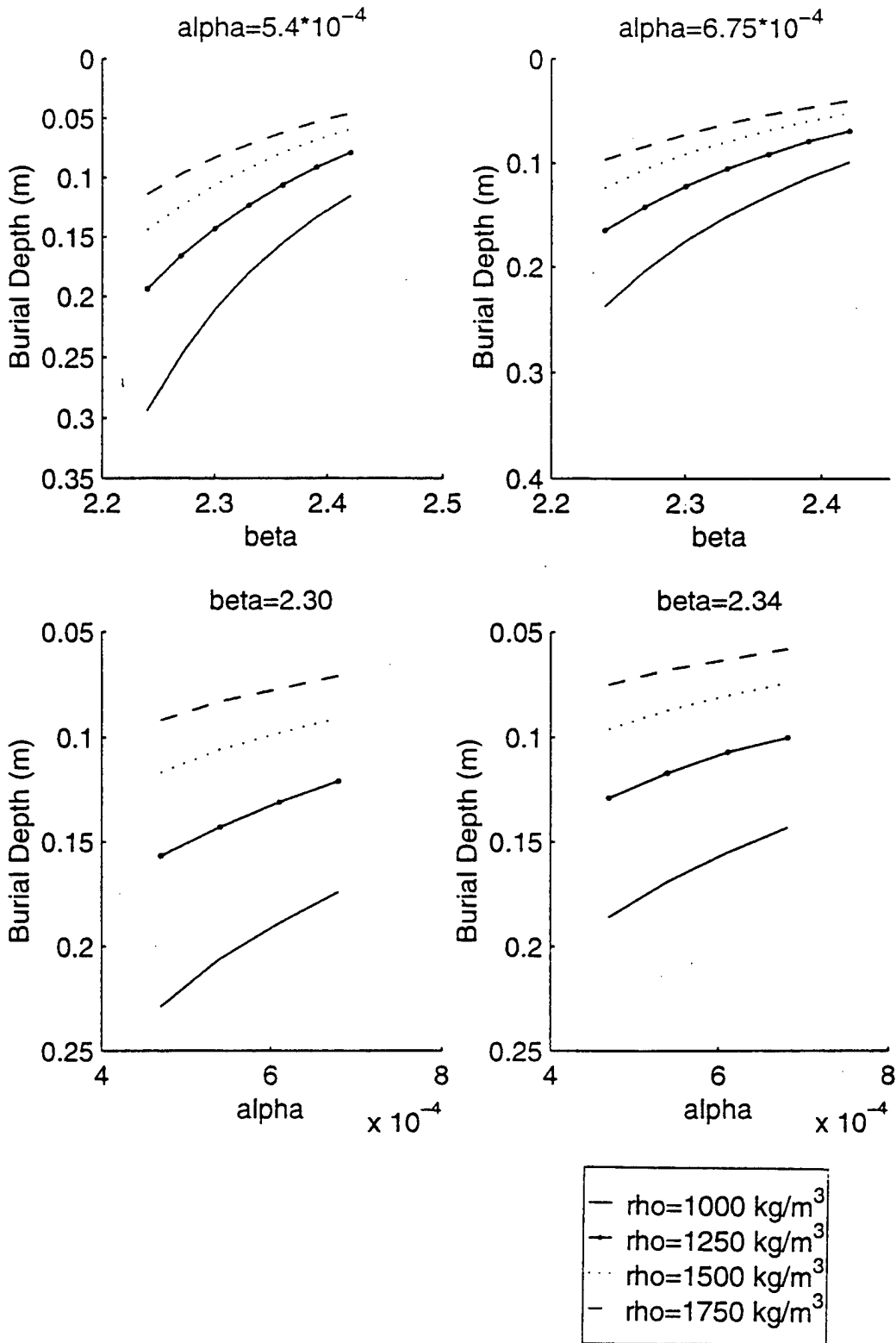

Figure 11. Effect of α and β coefficients on predicted burial depth (m).

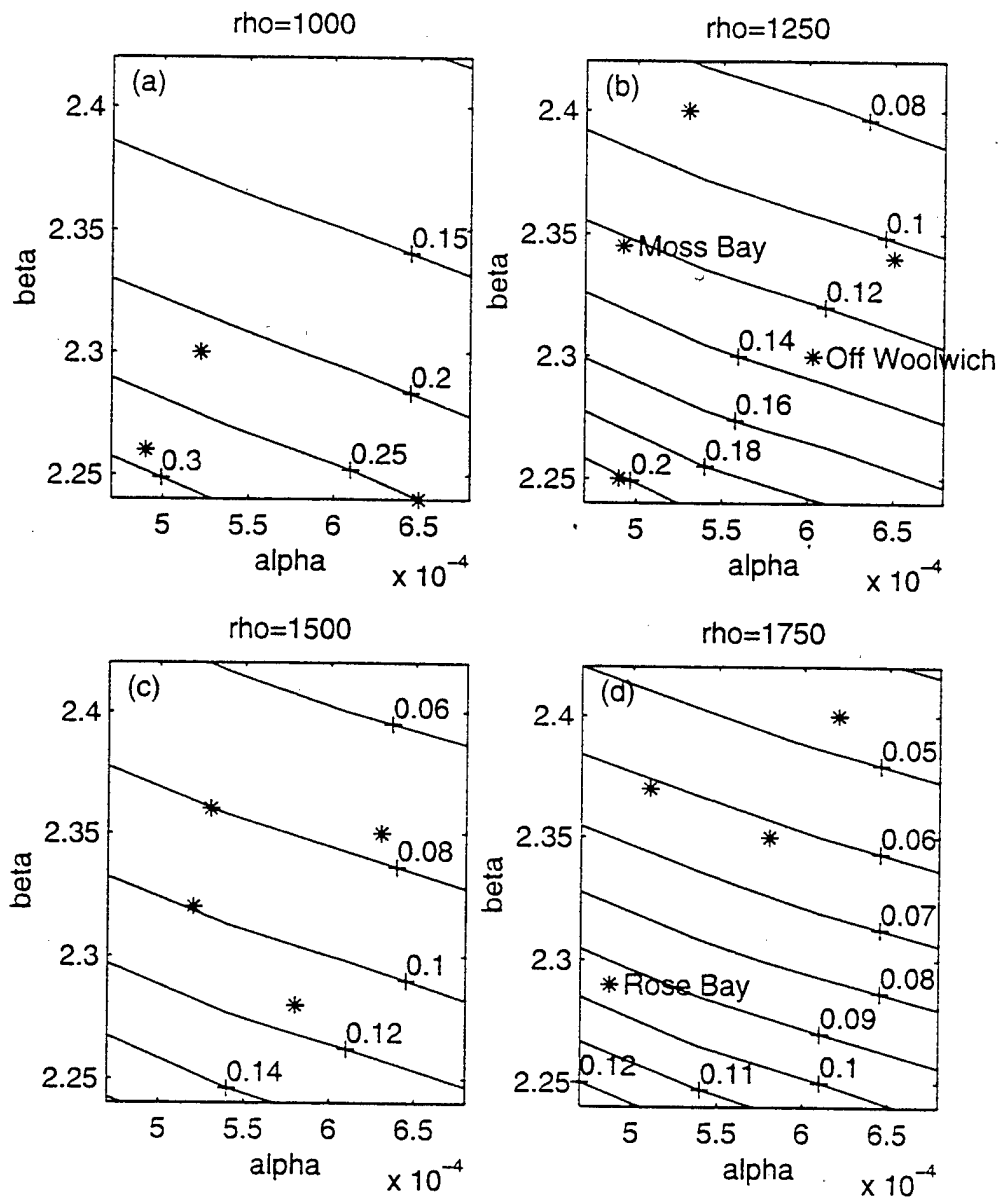

Figure 12. Contour plots of predicted burial depth (m) with respect to α and β coefficients. Asterisks mark the values of α and β that correspond to the interface values of the three sediment profiles from Mulhearn (1993) used in this study and to a subset of the Voelkner (1973) data set.

VI. RECOMMENDATIONS

As expected, there are several parameters that are both rarely known by the operator and of little import to the outcome of the model. In order to make the model easier to use without sacrificing accuracy, these parameters should be simplified as much as possible.

Water temperature was found to have no effect on burial depth, and should be eliminated from the list of variables. Altitude values should be simplified to represent a mine laying platform and the most likely height for release from that platform. For instance, it is more likely that an operator would know if the mines were laid by a ship or by a certain type of aircraft than the enemy has than at which altitude that aircraft was flying. Using intelligence and experience, one could form a rough database for selected platforms. The difference between an altitude of 1 meter and 300 meters is significant, but the difference between 1 meter and 5 meters is not.

An equation for terminal velocity could be built into the data entry program that takes the weight of the chosen mine into account and asks the user if the water depth is less than that which would produce terminal velocity in the water phase. Assuming no rotation rate was chosen, if the depth was known to be greater than required for terminal velocity, a depth need not be entered. This simplification would also allow the user to have some confidence in the result as he moves about the area, regardless of water depth changes.

The model could be revised to provide a range of values for burial depth, based on an initial attitude of 90° and 0° . In this way, the uncertainty of initial attitude and rotation rate would be eliminated and a more realistic range of values would be produced. This

may seem like a reduction in sophistication of the numerical model, but the reality is that the exact burial depth will never be known due to the unpredictability of the attitude of the mine as it encounters the sediment interface. This would also eliminate any effects due to currents or winds, since the primary effect of these influences would be on the attitude of the mine.

Further investigation is warranted to simplify the sediment profile data entry. Assuming the values for density and shear strength are either known or can be measured at the interface, a set of equations should be derived and refined to create the remainder of the profile. If this were an option in the model, while still allowing the user to enter the entire profile if known, it would substantially increase the usefulness and precision of the model. The few cases discussed here and the equations derived from that limited data set are encouraging, and may indicate that such equations are possible and beneficial.

A more precise method for simplifying the sediment data ingest would be to obtain samples from areas where mine clearing operations are likely to be accomplished. The relationship between density and shear strength for each sample would then be computed using the α and β coefficients discussed previously. The user could determine sediment type and density using available environmental atlases and the model would synthesize the profile.

LIST OF REFERENCES

1. Arnone, R. A., and Bowen, Prediction model of the time history penetration of a cylinder through the air-water-sediment phases. NCSC TN 734-36. Naval Coastal Systems Center, Panama City, FL, 1980.
2. Casper, L. E., Halter, I. L., Powers, E. W., Selva, P. J., Steffens, T. W., and Willis, T. L., Knowledge-based warfare: the security strategy for the next century. *Joint Force Quarterly*, Autumn, 81-89, 1996.
3. Gottshall, E.L, Environmental effects on warfare simulations. *Master Thesis*, Naval Postgraduate School, Monterey, CA, 1997.
4. Hamilton, E. L., and Bachman, R. T., Sound velocity and related properties of marine sediments. *J. Acoust. Soc. Am.*, 72(6), 1891-1904, 1982.
5. Hayter, E. J., Estuarine sediment bed model. *Estuarine Cohesive Sediment Dynamics*, edited by A.J. Mehta, pp. 326-359, Springer-Verlag, New York, 1986.
6. Krone, R. B., A study of rheological properties of estuarine sediments. *Technical Bulletin No.7, Committee of Tidal Hydraulics*. U.S. Army Corps of Engineers. Vicksburg, MS, 1963.
7. Von Mises, R., *Theory of Flight*, Dover Publ., New York, 1959.
8. Mulhearn, P. J., Experiments on mine burial on impact-sydney harbour. *U.S. Navy J. of Underwater Acoustics*, 43, 1271-1281, 1992.
9. Naval Mine Warfare Engineering Activity (NMWEA), U.S. navy mine countermeasures familiarizer. Naval Coastal Systems Center, Panama City, FL, 1991.
10. Naval Surface Warfare Center, Mine countermeasures commander's tactical decision aid (MCM-CTDA). *Coastal Systems Station, Dahlgren Division*.
11. Noorany, I., Laboratory soil properties. *Handbook for Marine Geotechnical Engineering*, edited by K. Rucker, Jr., Naval Civil Engineering Laboratory, Port Heuneme, CA, 3.1-3.19, 1985.
12. Satkowiak, L. J., Modified NCSC impact burial prediction model with comparisons to mine drop tests. NCSC TN 486-88. Naval Coastal Systems Center, Panama City, FL. Technical Note 934, 1988.
13. Satkowiak, L. J., User's guide for the modified impact burial prediction model. NCSC TN 884-87. Naval Coastal Systems Center, Panama City, FL, 1987.

14. Stanley, E. M., Viscosity of sea water at moderate temperatures and pressures, *J. Geophys. Res.*, 74, 3415-3420, 1969.
15. Voelkner, G. E., An analysis of data obtained from vane shear tests of recent marine sediment. *Master Thesis*, Naval Postgraduate School, Monterey, CA, 1973.

INITIAL DISTRIBUTION LIST

1. Defense Technical Information Center.....2
8725 John J. Kingman Rd., STE 0944
Ft. Belvoir, VA 22060-6218
2. Dudley Knox Library.....2
Naval Postgraduate School
411 Dyer Rd.
Monterey, CA 93943-5101
3. Chairman Code MR.....1
Department of Meteorology
Naval Postgraduate School
Monterey, CA 93943-5002
4. Chairman Code OC.....1
Department of Oceanography
Naval Postgraduate School
Monterey, CA 93943-5002
5. Professor Peter C. Chu Code OC/CU.....1
Department of Oceanography
Naval Postgraduate School
Monterey, CA 93943-5002
6. Professor Thomas Halwaches Code OR/HA.....1
Department of Operations Research
Naval Postgraduate School
Monterey, CA 93943-5002
7. Oceanographer of the Navy.....1
Naval Observatory
34th and Massachusetts Avenue NW
Washington, DC 20390-5000
8. Commander1
Naval Meteorology and Oceanography Command
Stennis Space Center, MS 39529-5000
9. Commanding Officer1
Naval Oceanographic Office
Stennis Space Center, MS 39522-5001

- 10. Chief of Naval Research..... 1
800 North Quincy Street
Arlington, VA 22217

- 11. Mr. Steve Haeger 1
Naval Oceanographic Office
Stennis Space Center, MS 39522-5001

- 12. LT Victoria L. Taber..... 1
Naval Postgraduate School
833 Dyer Rd. Room#304
Monterey, CA 93943

- 13. COMMINWARCOM..... 1
325 5th Street SE
Corpus Christy, TX 78419-5032

- 14. SPAWARSYSCEN 1
PMW185 METOC Systems
4301 Pacific Highway
OT-1 Room 1187
San Diego, CA 92110-3127

- 15. Dr. Phil Mulhearn..... 1
Aeronautical and Maritime Research Laboratory
Maritime Operations Division
PO Box 44
Pyrmont, NSW 2009
Australia