



**A Novel Manufacturing Processing  
Route for Forming High-Density  
Ceramic Armor Materials:  
Phase II - SBIR**

by Ramas V. Raman

ARL-CR-438

April 1999

prepared by

**Ceracon, Inc.  
1101 North Market Boulevard  
Suite 9  
Sacramento, CA 95834**

under contract

DAA-92-C-0068

**1 9 9 9 0 4 1 4 0 1 5**

Approved for public release; distribution is unlimited.

The findings in this report are not to be construed as an official Department of the Army position unless so designated by other authorized documents.

Citation of manufacturer's or trade names does not constitute an official endorsement or approval of the use thereof.

Destroy this report when it is no longer needed. Do not return it to the originator.

---

---

## Abstract

---

The feasibility of a combustion synthesis/Ceracon forging (CS/CF) fabrication process for low-cost high-quality ceramic armor is demonstrated. CS of titanium (Ti) and carbon (C) forming titanium carbide (TiC) was followed by a quasi-isostatic pressurization and densification to produce tiles with 95%+ densities with sizes of up to 15 cm × 15 cm × 2.5 cm. Several tiles were fabricated and delivered to the U.S. Army Research Laboratory (ARL) for evaluation and testing. A cost model, which showed that approximately 60% in cost savings can be realized with the CS/CF method, was developed.

Temperature measurements and one-dimensional (1-D) computations were used to develop thermal management practices to make crack-free tiles. X-ray diffraction (XRD) verified full conversion of reactants to products. A considerable variation in TiC grain size and microhardness was found between the surface (~10 μm, high hardness) and the interior (up to 100 μm, low hardness) that depended on conditions during processing. Fractography showed transgranular fracture in the interior and intergranular fracture at the surface. Quasi-static compressive strength was found to be 1.79 GPa, while the flexural strength, determined from four-point bending tests, was 0.17 GPa.

# Table of Contents

	<u>Page</u>
List of Figures .....	v
List of Tables .....	vii
Executive Summary .....	ix
Project Achievements .....	xi
<b>1. Introduction .....</b>	<b>1</b>
<b>2. Phase II Technical Objectives .....</b>	<b>2</b>
<b>3. Literature Search on CS of TiC .....</b>	<b>3</b>
<b>4. Background on the CF Process .....</b>	<b>4</b>
<b>5. Experimental Setup and Results .....</b>	<b>6</b>
5.1 Identification and Procurement of the Precursor Powders .....	6
5.1.1 Selection of Ti Particle Size .....	6
5.1.2 C .....	8
5.1.3 TiC .....	8
5.2 Powder Blending Process .....	8
5.3 Cold Preform Fabrication .....	10
5.3.1 Cold Compaction Pressure Optimization .....	10
5.3.2 Cold Compaction Process Determination .....	13
5.3.2.1 CIPing .....	13
5.3.2.2 UCIPing .....	16
5.3.2.3 Cold Pressing .....	17
5.4 Preparation of Tiles Prior to Consolidation .....	17
5.5 Preheating Schedule Prior to Forging .....	19
5.6 Effect of TiC Additions .....	21
5.7 CS/CF .....	21
5.7.1 The $t_{ign}$ After Being Placed in the PTM .....	22
5.7.1.1 Storage Time of Powders .....	22
5.7.1.2 Density of the Preform .....	23
5.7.1.3 Method of Wrapping the Grafoil Around the Preform .....	23
5.7.1.4 Part Preheat Temperature .....	23

	<u>Page</u>
5.7.1.5 <i>PTM</i> .....	23
5.7.2 <i>The <math>t_{burn}</math> From the First Ignition Until Pressure Application</i> .....	24
5.7.3 <i>Effect of Pressure</i> .....	24
<b>6.    Thermal Management to Prevent Crack Formation</b> .....	<b>24</b>
<b>7.    Characterization</b> .....	<b>32</b>
7.1            Specimen Preparation .....	32
7.2            Microstructural Characterization and Phase Analysis .....	32
7.3            Mechanical Properties .....	33
7.3.1 <i>Microhardness</i> .....	33
7.3.2 <i>Compression Strength and Modulus of Rupture Strength</i> .....	35
7.3.3 <i>Fracture Toughness</i> .....	36
7.3.4 <i>Elastic Modulus</i> .....	36
7.3.5 <i>Dynamic Mechanical Properties</i> .....	38
<b>8.    Machining of CS/CF Tiles</b> .....	<b>39</b>
8.1            Ceramic Machining and Grinding .....	39
8.2            EDM .....	39
8.3            Water-Jet Cutting .....	40
<b>9.    Cost Model to Manufacture</b> .....	<b>40</b>
<b>10.   Phase II Accomplishments</b> .....	<b>41</b>
<b>11.   Recommendations for Phase III</b> .....	<b>41</b>
<b>12.   References</b> .....	<b>43</b>
<b>Appendix A: Process Conditions for 55 TiC Tiles Having Approximate Dimensions 5 cm × 5 cm × 2 cm and 10 TiC Tiles Having Approximate Dimensions 10 cm × 10 cm × 2.5 cm</b> .....	<b>47</b>
<b>Appendix B: Drawings of the Cold Press, Ceracon Die, and UCIP Die</b> .....	<b>53</b>
<b>Appendix C: Cost Model for the Manufacture of 1,000 Tiles</b> .....	<b>69</b>
<b>Distribution List</b> .....	<b>85</b>
<b>Report Documentation Page</b> .....	<b>89</b>

## List of Figures

<u>Figure</u>	<u>Page</u>
1. The Ceracon Process .....	5
2. Schematic of Setup to Determine the Effect of Pressure on Combustion Wave Propagation .....	11
3. Effect of CIP Pressure on the Green Density .....	13
4. Setup Used to Measure Reaction Temperatures .....	25
5. Effect of PTM Type on Cooling Characteristics of CSed TiC .....	26
6. Experimentally Determined Temperature Time Plots for Different Compact Diameters .....	27
7. Temperature Distance Plots for Different Times With (a) Al <sub>2</sub> O <sub>3</sub> -Based PTM at Room Temperature and With (b) Al <sub>2</sub> O <sub>3</sub> -Based PTM at 500° C .....	29
8. Comparison of Measured and Completed Temperature Histories for (a) Al <sub>2</sub> O <sub>3</sub> -Based PTM and (b) Graphite-Based PTM .....	30
9. XRD for a 10-cm × 10-cm Tile (Co-K <sub>α</sub> Radiation) .....	33
10. Grain Size vs. Position Along Cross Section for (a) 6.35-cm-Square and (b) 10.2-cm-Square Cross-Sectional TiC Tiles .....	34
11. Hardness Traverses Along a 10.2-cm Sample Cross Section .....	35
12. Fracture Surfaces in (a) Flexure and (b) Compression Specimens .....	37
13. Fracture Surface Close to the Specimen Surface .....	38
14. CS/CF 15-cm × 15-cm × 2.5-cm TiC Tiles .....	40
B-1. Titanium Carbide (TiC) Cold Press Assembly .....	55
B-2. TiC Cold Press Die .....	56
B-3. TiC Cold Press Die Plate .....	57

<u>Figure</u>	<u>Page</u>
B-4. TiC Cold Press Punch .....	58
B-5. TiC Cold Press Punch Nose .....	59
B-6. TiC Cold Press Load Blocks .....	60
B-7. Guide Post Modifications .....	61
B-8. 20-cm-Square Die Assembly No. 1 .....	62
B-9. 20-cm-Square Die Assembly No. 2 .....	63
B-10. Uniaxial Cold Isostatic Press (UCIP) Assembled Die .....	64
B-11. UCIP Left Side .....	65
B-12. UCIP Side Cap .....	66
B-13. UCIP Right Side .....	67
C-1. Flow Chart for Manufacturing of TiC Tiles .....	76

## List of Tables

<u>Table</u>	<u>Page</u>
1. Chemical Analysis and Cost Comparison of Starting Powders .....	7
2. Effect of Particle Size of Ti on Combustion and Densification Behavior of TiC ..	9
3. Effect of CIP Pressure on Green Density .....	12
4. Effect of CIP Pressure on Ignition Characteristics and Density of the (Ti+C) Preform .....	14
5. Effect of Drying the (Ti+C) Powder Prior to Compaction .....	15
6. Effect of Grafoil Thickness on Final Density and Ignition Time .....	18
7. Effect of Preheat Temperatures on TiC Consolidation .....	20
8. Effect of Presynthesized TiC Additions .....	21
9. Thermophysical Data Used in Computations .....	28
10. Compressive Strength of TiC .....	36
11. Young's Modulus of TiC .....	38
A-1. Process Conditions for 5-cm × 5-cm × 2-cm TiC Tiles .....	49
A-2. Process Conditions for 10-cm × 10-cm × 2.5-cm TiC Tiles .....	52
C-1. Equipment Purchase and Setup Costs .....	81
C-2. Manufacturing Costs of 1,000 TiC Tiles .....	83



INTENTIONALLY LEFT BLANK.

## Executive Summary

The U.S. Army is interested in the development of a manufacturing process for fabrication of low-cost, high-quality armor tiles for defeating enemy kinetic energy (KE) projectiles. The general objective of the Phase II effort is to demonstrate an upscaled combustion synthesis/Ceracon forging (CS/CF) process for the fabrication of low-cost ceramic armors. The objective of this Phase II Small Business Innovative Research (SBIR) effort was to demonstrate the successful utilization of a quasi-isostatic pressurization method to produce dense (>95%) titanium carbide (TiC) compacts. CS of TiC followed by quasi-isostatic densification using a granular pressure-transmitting medium (PTM) (the Ceracon Process) yielded compacts with densities exceeding 95% and sizes of up to 15 cm × 15 cm × 2.5 cm (6 in × 6 in × 1 in).

Temperature measurements at the compact surface were made and compared to calculated one-dimensional (1-D) computations. As expected, the cooling rate of compacts decreased as the compact diameter increased and as the temperature of the PTM increased. These modeling and experimental measurements yielded insight into thermal management practices to be used to make crack-free tiles. X-ray diffraction (XRD) showed that full conversion to TiC occurred. The lattice parameter from XRD analysis was 0.4334 nm. The grain size showed a considerable variation, being larger (up to 100 μm) at the interior of the compacts and smaller near the surface (~10 μm). The grain-size variation was dependent on compact size and determined by the cooling rate, which is higher at the surfaces. The quasi-static compressive strength was determined and found to be equal to 1.79 GPa. The flexural strength, determined from four-point bending tests, was equal to 0.17 GPa. Microhardness measurements were made along the cross section, and the values varied considerably with position, being higher at the surface than in the center. Fractography showed that the fracture surface varied from transgranular in the center to intergranular at the surface. The microstructure and mechanical properties of the synthesized/densified compacts were addressed, and the results were favorable. The cohesion of the grains was excellent, and the compressive and tensile strengths were acceptable. Prototype quantities of 15-cm × 15-cm × 2.5-cm tiles were fabricated and

delivered to the U.S. Army Research Laboratory (ARL)\* for evaluation and testing. A cost model was developed based on the prototype tile fabrication experience. The model showed that approximately 60% in cost savings could be realized in the fabrication of TiC via the process developed in this program.

---

\* On September 1992, the U.S. Army Ballistic Research Laboratory (BRL) was deactivated and subsequently became part of ARL on 1 October 1992.

## Project Achievements

**Originality and Innovation of the Research.** The combustion synthesis (CS) process involves initiation of a self-propagating reaction at low temperatures between elemental components to synthesize a high-temperature compound (i.e., titanium [Ti] and carbon [C] react to form titanium carbide [TiC]). However, a stand-alone CS process produces a material with 50% porosity. The Ceracon forging (CF) process involves application of pressure on a hot, porous structure using a granular carbonaceous pressure-transmitting medium (PTM). The Ceracon innovation is to combine the CS and CF processes in one step (CS/CF), whereby in-situ synthesis and densification can be carried out. The hot carbonaceous particulate in the CF process serves as a combustion initiator and PTM. Such dual use of a particulate medium for synthesis and densification is novel and original. This technique has been successfully applied under the U.S. Army Research Laboratory's (ARL) support to fabricate large-size (15 cm × 15 cm × 2.5 cm [6 in × 6 in × 1 in]) TiC tiles.

**The Relevance of the Research to the Army and Its Mission.** The U.S. Army's mission is increasing to support technologies that have use in both military and commercial applications. The CS/CF process technology fulfills both criteria of relevance and specific mission. The cost analysis for the CS/CF process shows that a dramatic decrease in cost is feasible with the process developed via the Small Business Innovative Research (SBIR) support. At the same time, the same process is also applicable for the fabrication of heating element materials for high-temperature furnaces, cutting tools, and Ti- and nickel (Ni)-base alloys for automotive and aerospace applications.

**The Immediate Commercialization Potential of the Research.** The potential for commercialization of any new technology is dependent on four factors: (1) the need for a product made using this technology, (2) the cost of the product, (3) the cost of acquiring the technology, and (4) the quality of the product. Ceracon has identified an immediate need in the areas of cutting tools, automotive parts, and heating elements. Our cost model shows feasibility of lowering the cost by 60% of the current market prices. The capital equipment required is simple, off-the-shelf, and inexpensive. The quality of the product made using this technology has been found to be equal or

superior to the products made by current processes. Therefore, the immediate commercialization potential of this research is rated very high.

# 1. Introduction

The fabrication of dense compacts utilizing combustion synthesis (CS) in combination with a consolidation method is a very attractive technology. Developed in Russia by Merzhanov and coworkers (Merzhanov and Borovinskaya 1972; Merzhanov 1990), CS is being actively researched in the U.S. (Holt and Munir 1986; Munir 1988; Yi and Moore 1990) and Japan (Yamada, Miyamoto, and Koizumi 1987; Adachi et al. 1989). In the case of titanium carbide (TiC), the combustion product has a high porosity and densification through the application of external forces is necessary. Hot pressing during or after reaction (Yamada, Miyamoto, and Koizumi 1987; Adachi et al. 1989; Rice 1990; Riley and Niiler 1987) has been applied with considerable success. Dynamic consolidation by explosives was introduced in the U.S. by Niiler and coworkers (Niiler et al. 1988; Kecskes, Kottke, and Niiler 1990; Niiler, Kecskes, and Kottke 1992) and followed by Rabin, Korth, and Williamson (1990) and Grebe et al. (1992); Russian effort in this area occurred simultaneously (Shikhverchiev et al. 1992; Molokov and Mukasyan 1992). Consolidation using a high-speed (12–17 m/s impact velocity) forging press yielded fully dense compacts (LaSalvia, Meyer, and Meyers 1992; Hoke et al. 1992; Vecchio et al. 1992; Meyers et al. 1993).

The objective of this Phase II Small Business Innovative Research (SBIR) effort is to demonstrate the successful utilization of a quasi-isostatic pressurization method to produce dense (>95%), large TiC tiles measuring 15 cm × 15 cm × 2.5 cm (6 in × 6 in × 1 in). This technique (the Ceracon forging [CF] process) presents unique advantages over the other methods because it uses a granular medium to transmit the pressure to the part. This granular medium enables a great degree of freedom in the shapes to be synthesized and can be preheated to ignite the reactive green powder compact, so that an ignition mechanism is no longer needed. The thermal properties of the pressure-transmitting medium (PTM) are also very favorable, and thermal stresses (leading to cracking) in reacted/densified compacts can be minimized.

## 2. Phase II Technical Objectives

The general objective of the Phase II effort is to demonstrate an upscaled CS/CF process for the fabrication of low-cost ceramic armors for the U.S. Army Research Laboratory (ARL).

The specific goal of the Phase II effort is to demonstrate prototype fabrication of TiC armor tiles having dimensions of 15 cm × 15 cm × 2.5 cm; having a minimum of 95.57% density; and meeting all mechanical property requirements, including microhardness, modulus, and compressive-strength requirements specified by the Army/ARL for TiC material. A subobjective is to demonstrate the low cost of this process, as supported by a projected cost analysis for a scaled-up manufacturing system that uses cost data input for Phase II prototype fabrication. The objectives of the Phase II effort are:

- to demonstrate the feasibility of fabricating TiC tiles having dimensions ~15 cm × ~15 cm × ~2.5 cm in prototype quantities using an upscaled CS/CF process;
- to demonstrate that the material is free of chemical impurities above a level of 0.015%;
- to demonstrate that crack-free integral TiC tiles having a minimum density of 95.57% can be fabricated;
- to demonstrate that the material meets mechanical property requirements such as microhardness, compressive strength, fracture toughness, elastic modulus, and dynamic properties;
- to demonstrate that the material has a fine grain size and is chemically and microstructurally homogeneous;
- to provide ARL with TiC tiles for testing and field evaluation; and

- to provide the Army with a plan for manufacturing TiC and a cost model for price per kilogram and projected savings relative to conventional manufacturing of TiC armor.

### 3. Literature Search on CS of TiC

TiC has been synthesized by combustion and consolidation by dynamic compaction (Kecskes, Kottke, and Niiler 1990; Niiler, Kecskes, and Kottke 1990). Samples with relative densities of 98% have been prepared. Their hardness was equal or better to that obtained with conventionally prepared (commercial) materials. The hardness, however, showed a dependence on the stoichiometry of the TiC phase. The maximum hardness corresponded to a carbon/titanium (C/Ti) ratio of 1.0. However, at this ratio, the process of densification is not optimum and it was concluded that an ideal C/Ti ratio of 0.90 to 0.95 would give the desired combination of ease of densification and high hardness. This observation is in contrast to that made by Miyamoto and Koizumi (1990). These authors synthesized and consolidated  $TiC_x$  in one step, using what they refer to as "gas-pressure combustion sintering." Under an argon (Ar) gas pressure of 100 MPa, they were able to obtain fully dense  $TiC_x$  for 0.5/x/0.8. A higher x value resulted in lower density products. The authors explain this in terms of having excess C that inhibits densification in samples with  $x > 0.8$ . Another important parameter that influences the densification and the microstructure of TiC is the nature and level of impurities. Impurities of iron (Fe) were found to degrade the properties of the carbide by segregating at the grain boundaries (Kecskes, Kottke, and Niiler 1990). Other impurities in the reactants (Ti+C) can also play a role in the densification and microstructural development of the carbide (Kecskes, Kottke, and Niiler 1989). The major noncondensable impurities that were detected in the gas phase above the heated reactants include water ( $H_2O$ ), hydrogen ( $H_2$ ), carbon monoxide (CO), carbon dioxide ( $CO_2$ ), and hydrocarbons. Most of these types of impurities can be expelled by outgassing the reactant mixture at 500° C for several hours.

TiC has also been CSed and densified to 95% by the applications of uniaxial pressure (Holt and Munir 1986). The application of 27.6-MPa pressure resulted in a TiC microstructure with a typical grain size of approximately 20  $\mu m$ . In agreement with the observations of Niiler and coworkers



(Kecskes, Kottke, and Niiler 1989; Niiler, Kecskes, and Kottke 1990), the gases that evolved during combustion were found to contain a significant amount of  $H_2$ . It was proposed that the presence of this gas is the result of an oxidation reaction of the Ti metal by  $H_2O$  vapor or the evolution of dissolved  $H_2$  from Ti. The latter interpretation is especially important in cases where the Ti is prepared from a hydride phase.

There are also reports of investigations on the synthesis and densification of TiC-containing composites. Composites such as TiC + alumina ( $Al_2O_3$ ) are commercially important as cutting tools. TiC is added to  $Al_2O_3$  to enhance toughness and limit undesirable grain growth. However, in the sintering of these composites, undesirable gas evolution leads to pore formation. Gas evolution in this case is the consequence of interaction between TiC and  $Al_2O_3$  (Kim and Lee 1989). This composite has been investigated with respect to the feasibility of transformation toughening through the addition of zirconia ( $ZrO_2$ ) (Cutler, Virkar, and Holt 1985). In another investigation, it was found that a composite of  $Al_2O_3$  + 30-weight-percent TiC could be sintered to a density of >97% at 1,950° C if the heating rate up to this temperature is >200° C/min (Borom and Lee 1986). Presumably higher heating rates diminish the extent of the interaction between  $Al_2O_3$  and TiC. As indicated previously (Kim and Lee 1989), such an interaction leads to the formation of gaseous products that decrease the ultimate relative density of the composite. Prior to this work, consistently fabricated high-density TiC tiles have not been feasible without the addition of Ni or molybdenum (Mo) metal.

## 4. Background on the CF Process

The Ceracon process is a patented (U.S. Patent No. 4,539,175 [Lichti and Hofstatter 1985]), low-cost powder metallurgy process for achieving near-net-shaped, full-density parts. It is a simple consolidation technique that utilizes conventional powder metallurgy equipment and setup. The Ceracon process is a quasi-isostatic, hot consolidation technique that utilizes a ceramic particulate material as a PTM instead of a gas media as used in hot isostatic pressing (HIPing). Pressure up to 1.24 GPa can be used, and materials can be processed at unlimited upper temperatures. The process consists of four steps, as detailed in Figure 1: (1) fabrication of green preform, (2) part heating and

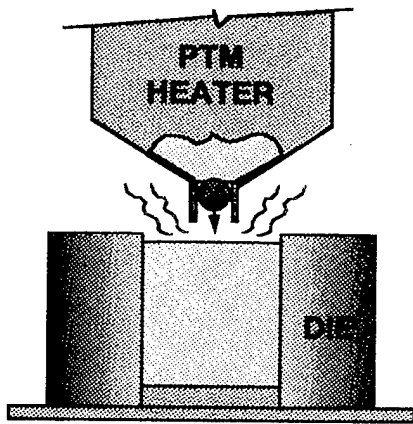

**1. Pressure transmitting media (PTM) fills the die**

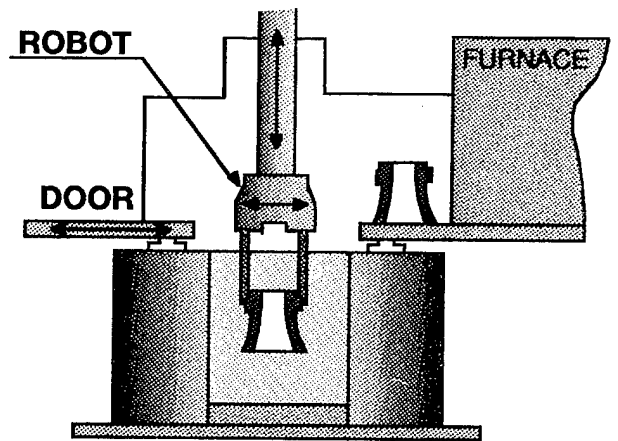

**2. Heated preform is inserted into the PTM by robot**

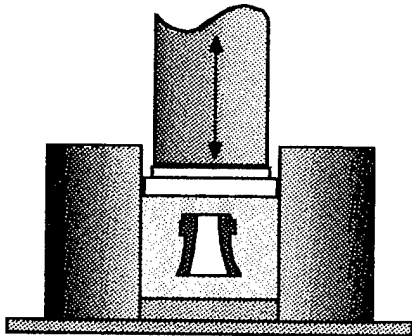

**3. Hydraulic press ram pressurizes the grain & consolidates the part to full density**

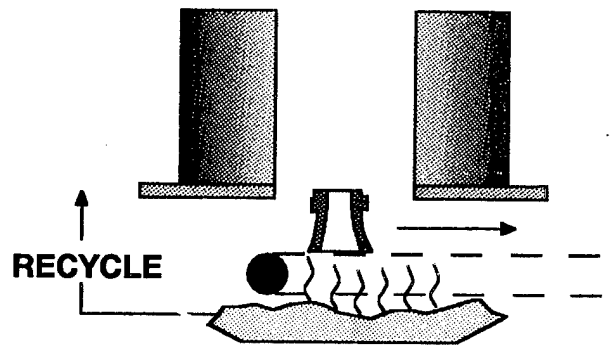

**4. The die is cleared and the PTM is recycled**

**Figure 1. The Ceracon Process.**

grain heating and transfer to the Ceracon die, (3) consolidation, and (4) part removal and grain recycling.

The low temperature coupled with short time consolidation capabilities of the quasi-isostatic, hot-consolidation, high-pressure process has been applied to a broad range of material systems (Raman, Rele, and Kapoor 1992; Raman and Rele 1993). The various systems processed include Al 6061 and 2124, tool steel, 46XX steel, Al-Fe-V-Si, TiAl, Cu, Nd-Fe-B supermagnets, superalloys, Al-SiC MMCs, WC-Co to Fe, Nb alloys, and  $YBa_2Cu_3O_{7-x}$  superconductors.

The idea of using a PTM to initiate self-propagating high-temperature synthesis (SHS) reaction and subsequently superimposing pressure on the part in situ had not been previously explored. This approach, if successful, will have significant advantages over thermite-induced SHS consolidation approaches because of:

- technology capability for consolidating net-shaped parts from conventional materials, such as steel, up to a 17.5-cm diameter  $\times$  60-cm length has already been demonstrated;
- thermal management of the specimen during and after processing is readily possible because of immediate specimen access after consolidation is completed; and
- the equipment is easy to set up and operate without the elaborate features required from other processes such as HIPing, hot pressing, and CS/explosive consolidation.

## 5. Experimental Setup and Results

### 5.1 Identification and Procurement of the Precursor Powders.

**5.1.1 Selection of Ti Particle Size.** Phase I of this program used Ultrafine MicroTi Ti (20  $\mu$ m) from Micron Metals, Salt Lake City, UT. This particle size was found to be suitable for the Phase I program (Raman, to be published) for smaller size specimens (<2.5-cm diameter and height); this was validated in a separate study by BRL (Raman and Niiler 1991). However, tiles of TiC with dimensions of 5 cm  $\times$  5 cm  $\times$  2 cm (2 in  $\times$  2 in  $\times$  0.79 in) or more were found to exhibit a markedly violent reaction with significant speed of the combustion wave, flare, and an audible explosion. The use of ultrafine Ti was thought to be the reason behind the deep laminar cracks and breaking up of the consolidated tile. Also, higher costs, safety issues arising from storage and use, and higher oxidation rate of ultrafine Ti powder necessitated a search for a coarser starting material.

Russian literature reports (Borovinskaya, Levashov, and Rogachev 1991) indicate that the use of coarser Ti powder slows down the velocity of the combustion wave front and may hence result in parts having significantly reduced cracks. Hence, coarser Ti powder (-100+150 mesh) was acquired from Micron Metals. The chemical analysis of the fine and coarse powders is given in Table 1.

**Table 1. Chemical Analysis and Cost Comparison of Starting Powders**

Species	-20- $\mu$ m Ti (%)	-100+150 Mesh Ti (%)	2- $\mu$ m C (%)	1.0-1.5- $\mu$ m TiC
Ti	>99.00	>99.40	N/A	79.7%
Al	<0.01	N/A	N/A	N/A
H	N/A	<0.02	N/A	N/A
Chlorides	<0.15	<0.15	N/A	N/A
Ca	N/A	N/A	N/A	<50 ppm
Fe	<0.08	<0.04	N/A	<300 ppm
Na	<0.15	<0.15	N/A	<20 ppm
S	N/A	N/A	N/A	<50 ppm
Si	<0.05	N/A	N/A	<20 ppm
N	<0.03	<0.01	N/A	<500 ppm
O	<0.32	<0.14	N/A	<0.6%
C (Total)	<0.01	<0.01	~99.90	19.4 $\pm$ 0.2%
C (Free)	N/A	N/A	N/A	<0.4%
C (Combined)	N/A	N/A	N/A	>19.0%
Supplier	Micron Metals	Micron Metals	CERAC <sup>a</sup>	H. C. Stark
Cost (\$/lb)	29	20	2	30

<sup>a</sup> Ceramic division of Alice Chalmers.

The ignition reaction of Ti powder (-100+150 mesh) was found to be significantly slower, and the wavefront traveled at a slower speed with a lower intensity of flare than with ultrafine

-20- $\mu$ m Ti. Fabrication of crack-free 5-cm  $\times$  5-cm  $\times$  1.25-cm (2 in  $\times$  2 in  $\times$  0.5 in) TiC tiles on a repeatable basis was made using the -100+150 mesh Ti powder. Hence this mesh size was determined to be the most optimum for this program. Ti powder of mesh size -60+100 was also tried out and found to have no significant improvement over the -100+150 mesh Ti powder regarding the cracking tendencies of the speed of the combustion wave. Table 2 compares the ignition and densities of 5-cm  $\times$  5-cm  $\times$  2-cm TiC tiles made using -100+150 mesh Ti powder and -60+100 mesh Ti powder.

It is seen that there is no significant difference in densities or in the ignition times by varying the particle size of the Ti. However, the TiC tiles made using the -100+500 mesh Ti powder displayed fewer cracks on an average, as compared to the ones made using the -60+100 mesh Ti powder.

**5.1.2 C.** In Phase II, the same 2- $\mu$ m graphitic C as that used in Phase I was selected. The chemical analysis and cost are shown in Table 1.

**5.1.3 TiC.** Very fine particle size (1-1.5  $\mu$ m) TiC additions were added as a diluent to further slow down the speed of the ignition wavefront in various amounts to the (Ti+C) tile. The chemical analysis of the TiC is shown in Table 1.

**5.2 Powder Blending Process.** Phase I of this program required smaller amounts of powder (batch size <250 g), and wet milling was used to blend the powders. Phase II required batch sizes of approximately 9 kg. Drying of such large batches became a long and arduous process, and the powders would not dry off completely. Discussion with the contracting officer's technical representative (COTR) and technical staff at ARL, as well as our consultant Prof. Marc Meyers (University of California-San Diego [UC-SD]), revealed that dry milling worked equally well; hence, dry milling for about 4 hr was consistently used for blending all the Ti and C powders for Phase II.

Aluminum (Al) jars 30 cm long  $\times$  17.5 cm diameter with an approximate volume of 7.5 liters, lined with silicone rubber Type M (supplier K. R. Anderson) were specially built for the blending

Table 2. Effect of Particle Size of Ti on Combustion and Densification Behavior of TiC

Ceracon No.	Grafoil Thickness (cm)	Mill			CIP Data			Forge Data					Theor. Density (%)
		Ti Size (mesh)	Height (cm)	Width (cm)	Length (cm)	PTM Temp. (°C)	Part Temp. (°C)	Time at Temp. (hr:min)	Time to Ignite (min:s)				
5397	0.038	Fine	1.905	5.080	5.080	1,208	705	0:25	4:00	96.5			
5399	0.038	Fine	1.918	5.088	5.090	1,212	701	0:17	—	96.2			
5401	0.038	Fine	1.918	5.088	5.090	1,212	802	0:45	4:05	95.7			
5415	0.038	Fine	1.961	5.174	5.461	1,209	698	0:46	4:17	93.2			
5413	0.038	Coarse	1.824	5.367	5.436	1,208	707	0:41	3:57	95.2			
5414	0.038	Coarse	1.874	5.392	5.481	1,208	703	0:31	4:49	95.9			
5402	0.064	Coarse	1.539	4.834	4.928	1,212	797	2:37	3:45	95.8			
5403	0.064	Coarse	1.529	5.278	5.283	1,213	800	3:38	3:36	95.9			
5404	0.064	Coarse	1.910	5.354	5.499	1,208	801	1:08	5:45	94.9			

Common Parameters	
Pressure	241 GPa
CIP <sup>a</sup> Press	69 MPa
Die Temperature	250° C
PTM Type	A-20 <sup>b</sup>
Particle Size	Fine (-100+150 mesh)
Particle Size	Coarse (-60+100 mesh)
Strain	Wide
Bleed	Inst.
Hold	0 s
Atmosphere	Ar at 566 liters/hr
Theor. Density	4.92 g/cm <sup>3</sup>
Cooling	Vermiculite

<sup>a</sup> CIP = cold isostatic press.

<sup>b</sup> A-20 = Al<sub>2</sub>O<sub>3</sub> PTM with 20 volume-percent 9,400 graphite.

process. A two-tier ball mill (U.S. Stoneware Model 784) was purchased for this project.  $ZrO_2$  cylinders (1.2 cm  $\times$  1.2 cm long) were used as the media and filled approximately 45–50 volume-percent of the mill jar. Ti and C powders in the 1:0.9 molar ratio (corresponding to 81.58-weight-percent Ti) were weighed out in a protective atmosphere and placed in the mill jar with the  $ZrO_2$  media. The mill jar was evacuated and back-filled with high-purity Ar and sealed. The mill jars were rotated at approximately  $65 \pm 5$  rpm for 4–6 hr. Each mill jar produced 2 kg of powder. Separation of the powder from the media was carried out in air. Initial techniques of manual separation were slow and took as long as 45 min to 1 hr; so, a device was built that reduced the separation time to less than 10 min. The blended powders were stored in sealed containers under Ar immediately after separation.

**5.3 Cold Preform Fabrication.** This task consisted of two subtasks involving optimization of pressure used in the cold compaction process and the process steps to enable consistent fabrication of crack-free uniform-density preforms:

- (1) cold compaction pressure and
- (2) cold compaction process.

**5.3.1 Cold Compaction Pressure Optimization.** Low densities of the green (Ti+C) preform give poor strength during handling prior to ignition. Low green strengths show a propensity toward cracking or breaking of the preform before and during the CS/CF cycle. Higher green densities, on the other hand, have been shown (LaSalvia 1990) to result in higher thermal conductivity for the preform, resulting in incomplete propagation of the combustion wave front.

Cold isostatic pressing (CIPing) was used as the process to determine the effect of cold compaction pressure on:

- the green density,
- the time for the initiation of combustion,

- the time for completion of combustion, and
- the density of CS material.

Disks of (Ti+C) were CIPed at various pressures (55–380 MPa) into disks, approximately 4.5 cm in diameter and 1 cm thick. These were inserted into a furnace preheated to 1,200° C in air, one at a time. A video camera was set up to enable recording of the combustion wave. This setup is shown in Figure 2. Table 3 and Figure 3 show the expected result of increasing green density with increasing CIP pressure.

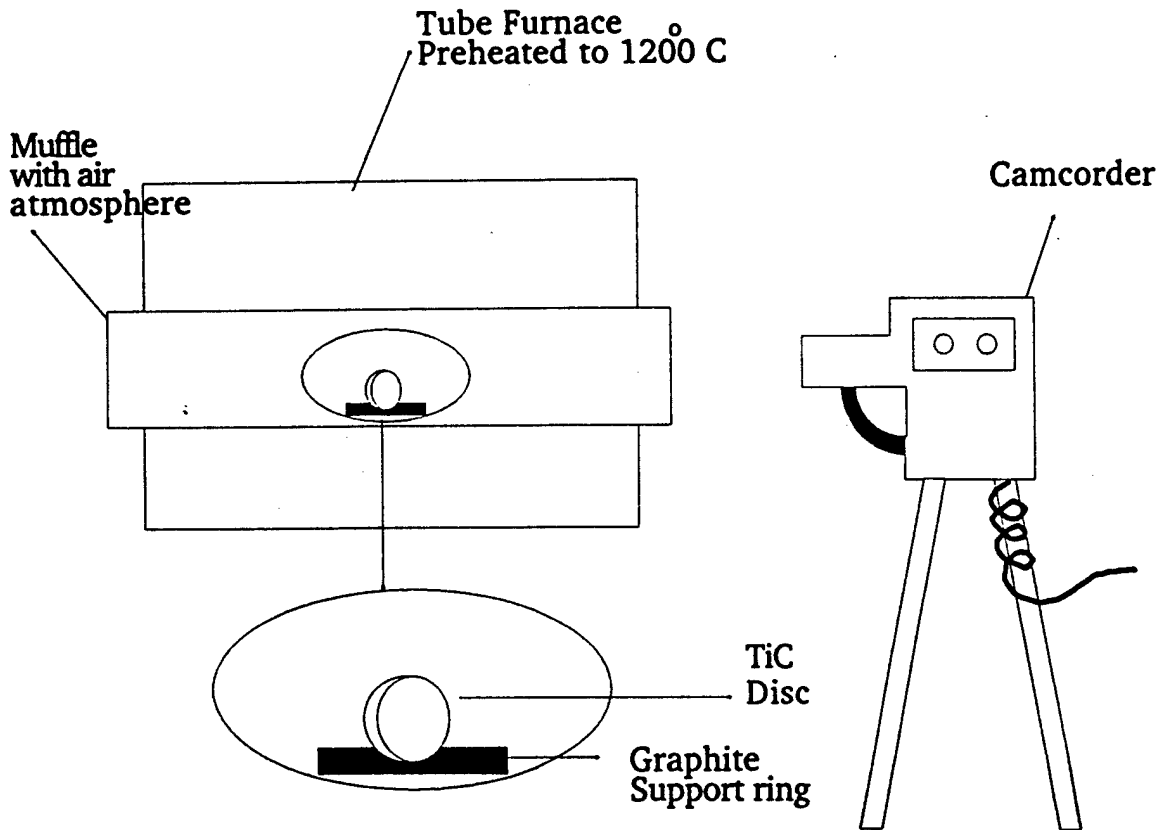

**Figure 2. Schematic of Setup to Determine the Effect of Pressure on Combustion Wave Propagation.**

After insertion of the preform disk into the 1,200° C furnace environment, a wave was seen to initiate at the top edge of the disk. This wave would travel through the disk, and the disk would flare



**Table 3. Effect of CIP Pressure on Green Density**

CIP Pressure (MPa)	Density (g/cm <sup>3</sup> )	Theor. Density (%)
28	2.37	62
55	2.69	71
83	2.86	75
138	3.07	81
241	3.25	85
310	3.27	86
379	3.31	87
Common Parameters		
Atmosphere .....	Air	
PTM Type .....	9,400	
PTM Temperature .....	1,200° C	
CIP Cube .....	2.41 cm × 2.41 cm × 2.41 cm	
Theor. Density (Ti+C) .....	3.81 g/cm <sup>3</sup>	

up into a conflagration. The time prior to wave initiation, the time from the initiation to flare-up, and the extent of wave travel before the flare are shown in Table 4.

With an increase in CIP pressure, it takes a longer time to ignite the preform. This is in accordance with the literature (LaSalvia 1990), whereby researchers have noted increased thermal conductivities with increased green densities, which result in channeling away the heat, resulting in longer times for ignition. Also with increasing green densities, the time from wave initiation to flare-up was reduced, which resulted in increased violence in flare-up. This caused a larger degree of breaking up and cracking of the part after CS. CIP pressure below 55 MPa would produce very fragile and difficult-to-handle preforms. Based on the integrity of the part after CS, it was determined that optimum green densities are obtained by cold compaction around 83 MPa.

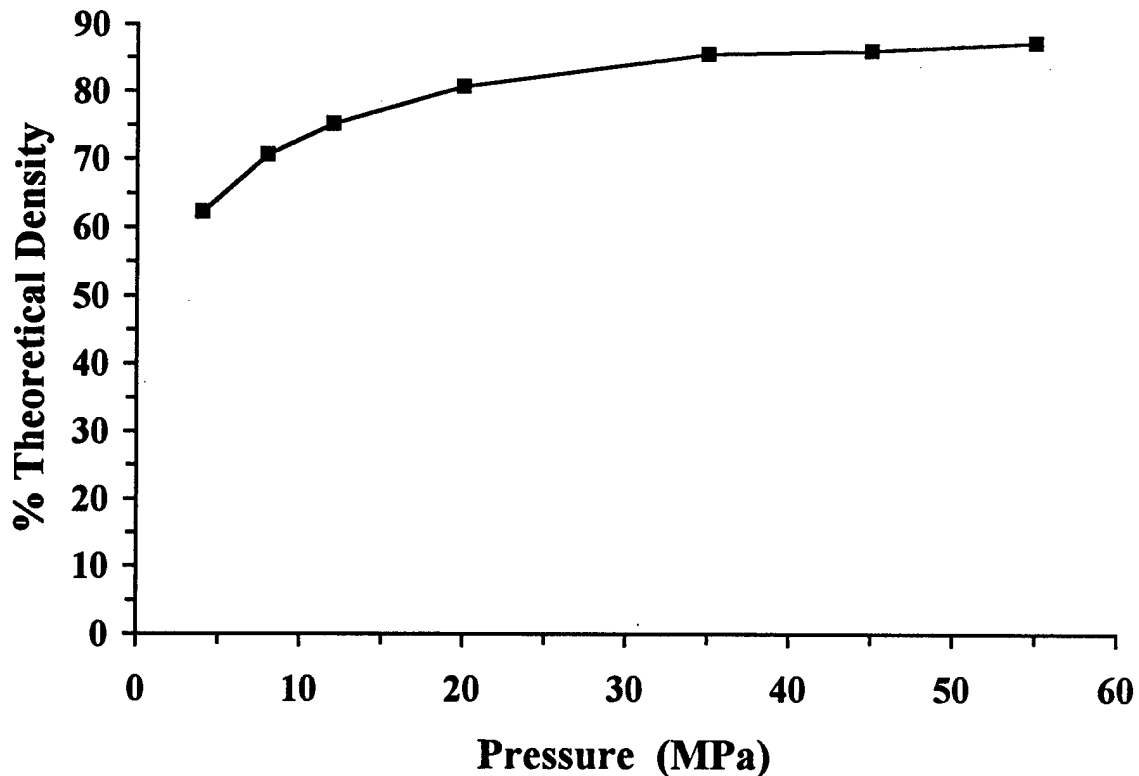







Figure 3. Effect of CIP Pressure on the Green Density.

**5.3.2 Cold Compaction Process Determination.** Three routes were pursued for cold preform fabrication:

- (1) CIPing,
- (2) uniaxial cold isostatic pressing (UCIPing), and
- (3) cold pressing.

**5.3.2.1 CIPing.** CIPing of the (Ti+C) powders into integral crack-free parts was found to depend on several factors. It was required to CIP the preforms within 1–2 days of powder preparation. Conversations with Marc Meyers' group revealed that, for obtaining uniform crack-free parts, it was necessary to dry the parts (in a low-vacuum environment) at around 110° C. The effect of drying the powder is shown in Table 5.

**Table 4. Effect of CIP Pressure on Ignition Characteristics and Density of the (Ti+C) Preform**

CIP Pressure (MPa)	CIP Theor. Density (%) <sup>a</sup>	Time for Initiation of Combustion Wave (s)	Time From Initiation of Wave to Flare (s)	Post Ignition <sup>b</sup> Theor. Density (%) <sup>c</sup>	Wave Travel Before Flare
55	71	11	7	52.85	
83	75	13	9	53.46	
241	85	62	5	54.27	
310	86	79	5	53.46	
379	87	65	4	55.73	

Note: Conditions: CIP disk inserted into a furnace preheated to 1,200° C in air.

<sup>a</sup> Theor. Density (Ti+C) = 3.811 g/cm<sup>3</sup>.

<sup>b</sup> CSed, not consolidated.

<sup>c</sup> Theor. Density (TiC) = 4.92 g/cm<sup>3</sup>.

The following observations were made regarding the characteristics of the CIP process.

- CIPing of as-milled powders into integral crack-free preforms depends on the storage time of the powders before CIP. The longer the storage time, the greater the tendency for breaking during CIP.
- CIPing of powders dried at 110° C, within a few hours of the drying process, consistently produces parts that are crack-free. However, once again, longer storage times led to cracking probably due to oxidation and/or absorption of excessive moisture, which is released during thermal exposure of the specimen.

**Table 5. Effect of Drying the (Ti +C) Powder Prior to Compaction**

Ceracon No.	PTM Type	Strain (cm/cm)	Decompression	Cooling Method	Density (g/cm <sup>3</sup> )	Theor. Density (%)	Drying Method
5158	A-75	Wide	Instant	Inserted in furnace at 1,100° C	4.37	89	Not Dried
5159	A-75	Wide	Instant	Inserted in furnace at 1,100° C	4.82	98	Dried 24 hr at 110° C
5160	A-75	Wide	Instant	Inserted in furnace at 1,100° C	4.80	98	Dried 24 hr at 110° C
5161	A-75	Wide	Instant	Inserted in furnace at 1,100° C	4.81	98	Degassed at 500° C and 600 μm of mercury (Hg)
5162	A-75	60	Instant	Cooled overnight at 1,200° C	4.45	90	Degassed at 500° C and 600 μm of Hg
5164	A-20	Wide	Instant	Cooled in furnace at 1,100° C	4.54	92	Degassed at 500° C and 600 μm of Hg
5167	A-20	Wide	Instant	Cooled in furnace at 1,100° C	4.68	95	Degassed at 500° C and 600 μm of Hg

Notes: A-75 = Al<sub>2</sub>O<sub>3</sub> PTM with 75 volume-percent 9,400 graphite.

PTM temperature = 1,200° C.

Pressure = 6.2 × 10<sup>5</sup> TPa.

CIP pressure = 69 MPa.

Die height = 8.26 cm.

- CIPing of parts with one dimension significantly smaller than the others (for example, in a plate preform) is very difficult. This was simplified by making a block of (Ti+C) that was then cut up into several tiles.
- CIPing of parts does not give smooth edges. The edges have to be smoothed out by cutting with a saw blade.

Because of the aforementioned problems, the use of CIP as a manufacturing process was found to be doubtful. Hence, alternate cold-compaction routes were evaluated.

*5.3.2.2 UCIPing.* A unique idea for cold compaction of green preforms has evolved in this Phase II program. Cold pressing and CIPing are the established methods of green-preform fabrication.

Cold pressing offers advantages of smooth faces, sharp edges, and close dimensional tolerances. However, cold pressing requires upkeep and maintenance of expensive dies and punches, and operator error can easily scrap an expensive die set. Increasing part sizes leads to significant increase in cost.

The innovation of the UCIP process combines the advantages of cold pressing and CIPing. A die is fabricated through four ground tool steel plates and is bolted together. The punch and die are polyethylene blocks. The powder is filled in the same way as in cold pressing. The punch and die assembly is placed in a rubber bag, all of which is CIPed. Polyethylene punches significantly improve lubrication on die walls, and the life of punch and die are improved significantly. Further, replacement of either punch or die becomes very inexpensive. Since pressure application and release are slow and uniform, internal stresses on the part are minimized. To achieve the same density for a UCIPed part as for a cold-pressed part, a UCIP pressure twice that of the regular CIP pressure is required. At a UCIP pressure of 138 MPa, a green density of 65% is reached. The design drawings for the UCIP die for fabricating 15-cm × 15-cm × 2.5-cm tiles are attached in Appendix A.

**5.3.2.3 Cold Pressing.** Although the UCIP was a novel technique, the slower rate of production required use of a cold-pressing die. Also, the notched portions of the UCIP die required a redesign to increase the structural integrity.

Due to the need to stay on schedule, a decision was made to go with traditional cold pressing, and a die and punch system was designed, fabricated, and installed in the 2,500-ton press. This die was used successfully in pressing all the tiles required for the Phase II program.

**5.4 Preparation of Tiles Prior to Consolidation.** During the initial stages of Phase II, smaller samples were forged. These generated a relatively small increase in the surrounding PTM temperature. Hence the  $\text{Al}_2\text{O}_3$ -based PTM would not show significant bonding or sticking to the part. However, with increasing dimensions of the part, a larger amount of heat that melts a larger amount of  $\text{Al}_2\text{O}_3$  in the immediate vicinity of the part was generated. The fused and adhered PTM was seen to result in cracks in the CS/CF part. This perhaps could be attributed to the difference in the cooling rates and modulus between the molten/adhered  $\text{Al}_2\text{O}_3$  and the TiC.

Hence, it became necessary to introduce a barrier layer that would separate the TiC part from the PTM, withstand the very high temperatures associated with the CS process, would not bond to the part, and would not show any unfavorable reactions with the TiC tile. Graphite foil (commercially known as Grafoil) available in thicknesses of 0.038 cm and 0.064 cm from the Union Carbide Company was selected as the barrier layer. Table 6 shows the effect of the Grafoil thickness on the time to ignite and the final density.

It was observed that the Grafoil thickness does not affect the final density of the CS/CF 5-cm  $\times$  5-cm tiles. However, as expected, a thicker Grafoil resulted in a longer time for ignition. In turn, this caused slightly more cracking of the TiC tiles. A longer ignition time resulted in a greater degree of cooling for the PTM, which could result in a greater temperature difference between the part and the PTM and hence a greater thermal shock. For these very reasons, in addition to the lower cost, the thinner (0.4 mm) Grafoil was selected for this program.

**Table 6. Effect of Grafoil Thickness on Final Density and Ignition Time**

CIP Data			Forge Data								
Ceracon No.	Grafoil Thickness (cm)	Height (cm)	Width (cm)	Length (cm)	Part Temp. (°C)	Time at Temp. (hr)	Time to Ignite (min:s)	Final Height (cm)	Final Width (cm)	Final Length (cm)	Theor. Density (%)
Samples With Thin Grafoil											
5413	0.038	1.824	5.367	5.436	707	0.68	3:57	1.148	5.817	5.921	95.20
5414	0.038	1.874	5.392	5.481	703	0.52	4:49	1.247	6.015	6.083	95.90
Samples With Thick Grafoil											
5402	0.064	1.539	4.834	4.928	797	2.62	3:45	—	—	—	95.80
5403	0.064	1.529	5.278	5.283	800	3.63	3:36	—	—	—	95.90
5404	0.064	1.910	5.354	5.499	801	1.13	5:45	1.140	5.857	5.959	94.90
5405	0.064	1.882	5.639	5.809	798	1.07	5:20	1.158	5.855	5.918	96.20
Common Parameters											
Dimensions	5 cm x 5 cm										
Ti Particle Size	-60+100 mesh										
PTM	A-20 <sup>a</sup>										
PTM Temperature	1,200° C										
Die Temperature	250° C										
Theor. Density (TiC)	4.92 g/cm <sup>3</sup>										
Forge Pressure	2.41 x 10 <sup>5</sup> TPa										
Strain	Wide										
Bleed	Inst.										
Hold	0 s										
Atmosphere	Ar at 566 liters/hr										
Cooling	Vermiculite										

<sup>a</sup> A-20 = Al<sub>2</sub>O<sub>3</sub> PTM with 20 volume-percent 9,400 graphite.

The effectiveness of the Grafoil as a barrier was demonstrated when, in separate experiments, TiC tiles were wrapped with the Grafoil either only on the surface (i.e., the 5-cm × 5-cm faces) or on the sides (i.e., the 5-cm × 2-cm faces). It was seen that, when the parts were wrapped only on the surface, the Al<sub>2</sub>O<sub>3</sub> stuck on the sides and the tile showed laminar cracking. However, when the tiles were wrapped only on the side faces, the part showed surface cracking.

**5.5 Preheating Schedule Prior to Forging.** One of the drawbacks found regarding the use of Grafoil was that the foil increased the time to ignite from 3 to 4 min without Grafoil to almost 5 to 8 min with Grafoil wrapping. Also, it was seen that the ignition time range had broadened. This is very well seen in Appendix B. To reduce the ignition time and the ignition time range, higher PTM temperatures of 1,300° C and 1,400° C were attempted and proved to be as successful. However, manufacturing these tiles economically will require the temperatures to be 1,200° C or lower.

This led to the idea of preheating the preform prior to CS/CF. The objectives of achieving repeatable ignition times, achieving ignition with a PTM temperature of 1,200° C, and, in addition, eliminating an entire step of preheating and degassing the powder prior to cold pressing were all accomplished by the preheating step.

Table 7 shows the effect of preheating the (Ti+C) tiles at 700° C and 800° C using the -100+150 mesh powder as well as the -60+100 mesh powder. It was seen that both preheat temperatures resulted in parts with similar densities and similar ignition times. However, the 5-cm × 5-cm tiles preheated to 700° C showed a slight improvement over those preheated to 800° C, after the CS/CF process.

Higher temperatures of 850° C and 900° C, although attempted, were not considered viable for manufacturing, since these temperatures are precariously close to the start of the combustion reaction.

The time for which the tile was exposed to the preheat temperature was varied—0.5 hr, 1 hr, 1.5 hr, and 2 hr. The tiles preheated at 700° C for 0.5 hr after CS/CF looked the best and showed a perfectly crack-free surface. Longer times at the preheat temperature were thought to increase the oxidation of the Ti, resulting in slower ignition of the TiC tile.



Table 7. Effect of Preheat Temperatures on TiC Consolidation

Ceracon No.	Grafoil Thickness (cm)	CIP Data				Forge Data				
		Ti Size (mesh)	Height (cm)	Width (cm)	Length (cm)	PTM Temp. (°C)	Part Temp. (°C)	Time at Temp. (hr:min)	Time to Ignite (min:s)	Theor. Density (%)
5397	0.038	Fine	1.905	5.080	5.080	1,208	705	0:25	4:00	96.5
5399	0.038	Fine	1.918	5.088	5.090	1,212	701	0:17	—	96.2
5401	0.038	Fine	1.918	5.088	5.090	1,212	802	0:45	4:05	95.7
5415	0.038	Fine	1.961	5.174	5.461	1,209	698	0:46	4:17	93.2
5413	0.038	Coarse	1.824	5.367	5.436	1,208	707	0:41	3:57	95.2
5414	0.038	Coarse	1.874	5.392	5.481	1,208	703	0:31	4:49	95.9
5402	0.064	Coarse	1.539	4.834	4.928	1,212	797	2:37	3:45	95.8
5403	0.064	Coarse	1.529	5.278	5.289	1,213	800	3:38	3:36	95.9
5404	0.064	Coarse	1.910	5.354	5.499	1,208	801	1:08	5:45	94.9

Common Parameters	
Pressure .....	2.41 × 10 <sup>5</sup> TPa
CIP Press .....	69 MPa
Die Temperature .....	250 °C
PTM .....	A-20
Particle Size .....	Fine (-100+150)
Particle Size .....	Coarse
Strain .....	Wide
Bleed .....	Inst.
Hold .....	0 s
Atmosphere .....	Ar at 566 liters/hr
Theor. Density (TiC) .....	4.92 g/cm <sup>3</sup>
Cooling .....	Vermiculite

**5.6 Effect of TiC Additions.** A large grain size variation was noted in the TiC tiles across the length, as well as the height. This large variation was believed to crack a few of the tiles being made. Hence, very fine TiC was added to the (Ti+C) preform to understand the effect of this diluent on the density and cracking tendency. This is shown in Table 8.

**Table 8. Effect of Presynthesized TiC Additions**

Ceracon No.	TiC Addition (%)	PTM Temp.	Density	Cracks
5423	5	1,201	95.6	No Cracks
5426	5	1,306	94.4	No Cracks
5424	15	1,315	94.9	No Cracks
5425	20	1,313	94.3	No Cracks
5427	25	1,307	92.3	No Cracks
Common Parameters				
CIP Pressure	69 MPa	Grafoil	0.038 cm	
Part Preheat Temp.	700° C	Part	5 cm × 5 cm	
PTM	A-20			

Although the addition of TiC reduced the cracking in the CS/CF tile, it also adversely affected the density, reducing it to below acceptable levels. Hence, presynthesized TiC were not incorporated in the final manufacturing of tiles.

**5.7 CS/CF.** A CF die and punch set (having a square cavity to accommodate 15-cm-square tiles) was fabricated for the purpose of CS and CF of the 15-cm × 15-cm tiles. The drawings of these are attached in Appendix A.

The forging of these larger tiles required procedures similar to those of just in time (JIT) since the powder could not be stored for any length of time after the blending operation. Each of the tiles required milling of more than 3 kg of powder, and enough powder could be milled for only three tiles a day. A total of 11 kg of powder was milled every day.

More than 50 tiles of 15 cm × 15 cm × 5 cm were cold pressed. An informed and educated optimization cycle was carried out following experience gained with the 5-cm × 5-cm and the 10-cm × 10-cm TiC tiles. Appendix B lists all of the process parameters of the tiles. However, due to the upscaling process, several parameters had to be optimized. A summary of these modifications is provided next.

Two parameters were found to be critical for the CS/CF process:

- (1) time for first ignition ( $t_{\text{ign}}$ ) after being placed in PTM.
- (2) time allowed for the burn ( $t_{\text{burn}}$ ) process from the first ignition until pressure application.

**5.7.1 The  $t_{\text{ign}}$  After Being Placed in the PTM.** The process parameters that control  $t_{\text{ign}}$  are several. However, most of them have been optimized before. The parameters that were modified during this period included:

- (1) storage time of powders,
- (2) density of the preform,
- (3) method of wrapping the Grafoil around the preform,
- (4) part preheat temperature, and
- (5) PTM.

**5.7.1.1 Storage Time of Powders.** It has been recognized in the past that TiC tiles forged under identical conditions can show different  $t_{\text{ign}}$  depending on how long the powders have been stored from the time they were milled until the time they are forged. It has also been recognized that the storage time from milling to cold pressing requires more critical control than the time from cold pressing to

forging. For storage times of approximately 1 week,  $t_{\text{ign}}$ 's were consistently around 4.5 min. However, for storage times of three or more months,  $t_{\text{ign}}$  was between 6.5 and 10 min. In this period, an effort was made to have a consistent storage time of approximately 1 week.

*5.7.1.2 Density of the Preform.* This is among the most important parameters affecting  $t_{\text{ign}}$ . Previously, densities varied between  $2.94 \pm 0.09 \text{ g/cm}^3$  for the cold-pressed tile. In this period, the density was tightly controlled between  $2.7 \pm 0.04 \text{ g/cm}^3$ .

*5.7.1.3 Method of Wrapping the Grafoil Around the Preform.* It is recognized that the Grafoil wrap must prevent the PTM from contacting the hot part, both before and after consolidation. At the same time, Grafoil should allow for outgassing to occur during the reaction. Such a design for the Grafoil wrap was also accomplished. Modifications to Grafoil wrapping were carried out such that the Grafoil could support the much increased weight during transfer of the ~3-kg TiC tile.

*5.7.1.4 Part Preheat Temperature.* The part preheat temperature, based on prior experience, was selected such that it would not ignite the part in the furnace but, at the same time, would be high enough such that the additional heat provided by the PTM would ignite the part in the shortest possible time. The ratio of the tile volume to the surrounding PTM volume is much lower for the 15-cm  $\times$  15-cm green preform tile than either the 10-cm  $\times$  10-cm or 5-cm  $\times$  5-cm tile. It can be seen from Appendix B that, at part temperatures of 750° C (for the 15-cm  $\times$  15-cm tiles), as much as  $8 \pm 1$  min are required for ignition of the part. However, around temperatures of about 825° C, shorter times around  $4 \pm 0.5$  min are required. Thus, the preheat temperature was fixed near 825° C.

*5.7.1.5 PTM.* The PTM is also a very critical parameter in producing crack-free tiles. It has been recognized that the  $\text{Al}_2\text{O}_3$ -graphite combination grain plays an extremely important role and is superior to graphite-based PTM. It was seen from the tiles forged in the current reporting period that a higher  $\text{Al}_2\text{O}_3$  content may be better than a lower  $\text{Al}_2\text{O}_3$  content in the PTM. This is because a higher  $\text{Al}_2\text{O}_3$  content has a higher heat content and ignites the part faster; similarly, it also does not cool down slower, which reduces crack formation in the part. However, the TiC tiles do not spread as much in dimension with a higher  $\text{Al}_2\text{O}_3$  content in the PTM. It was found that with low- $\text{Al}_2\text{O}_3$  PTMs

(A-20), the horizontal spread was about 5%, whereas, with high- $\text{Al}_2\text{O}_3$  PTMs (A-8), the horizontal spread was less than 2%. So, although the high- $\text{Al}_2\text{O}_3$  PTM can reduce crack formation, it also gives less room for machining a 15-cm  $\times$  15-cm tile. A high- $\text{Al}_2\text{O}_3$  content (A-8) was selected as the PTM for the Phase II SBIR.

**5.7.2 The  $t_{\text{burn}}$  From the First Ignition Until Pressure Application.** Previously, in Phase I, the burn time was controlled through visual observation of the flame on top of the PTM column. In Phase II, the  $t_{\text{burn}}$  varied between 0.5 min and 5.5 min. Based on plots of  $t_{\text{burn}}$  against density of the tile, it was found that with lower burn times the part would still be combusting during pressure application and the tile would be severely cracked. Whereas, with a longer  $t_{\text{burn}}$ , the tile density would seem to drop. An optimized  $t_{\text{burn}}$  was decided to be between 2 and 2.5 min.

**5.7.3 Effect of Pressure.** Experiments were also conducted to determine the effect of forging pressure on the density of the part. Initial experiments revealed that, by lowering the pressure from  $2.75 \times 10^5$  TPa to  $1.38 \times 10^5$  TPa, the density dropped by about 0.3% of the theoretical.

The CS/CF of TiC tiles was carried out using the processing conditions, part preparation procedure, and processing parameters established from the previously discussed experimental work.

## 6. Thermal Management to Prevent Crack Formation

Cracking of the TiC during cooling has been found to be a severe problem by Niiler and coworkers (Niiler et al. 1988; Kecskes, Kottke, and Niiler 1990; Niiler, Kecskes, and Kottke 1992) and LaSalvia, Meyer, and Meyers (1992) and during Phase I and the initial phase of the Phase II investigation. Therefore, the cooling of the compacts was experimentally determined. The experimental configuration to measure the temperatures of the compacts during and after reaction is shown in Figure 4 and is similar to the setup used by Dunmead, Munir, and Holt (1992).

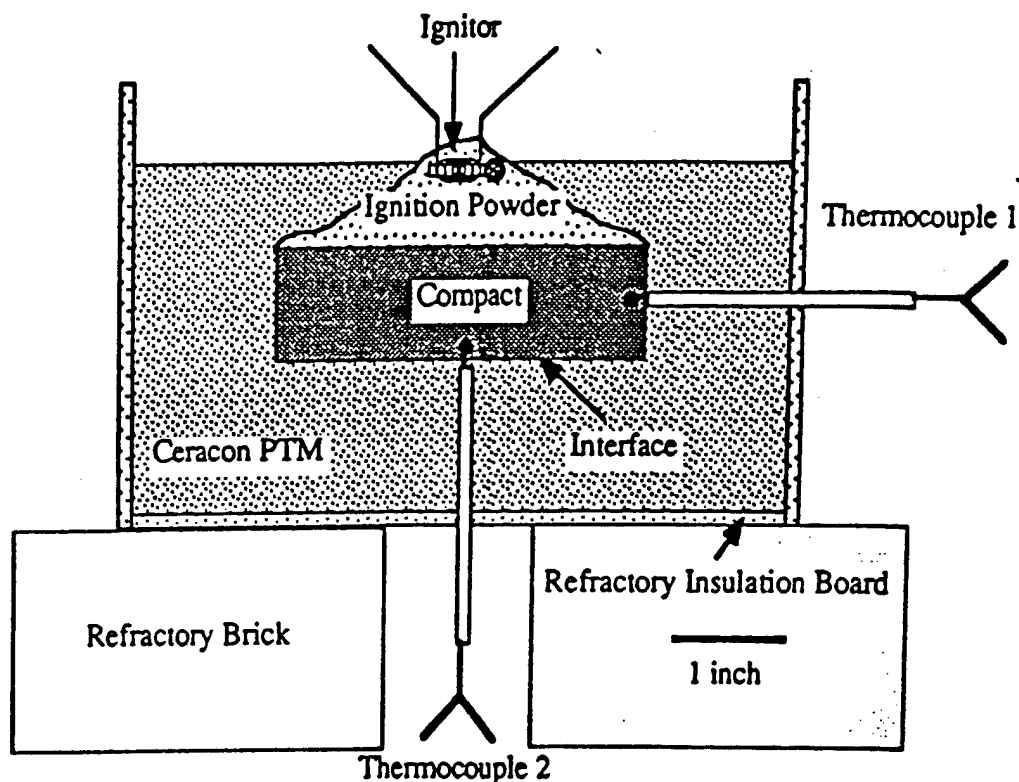

**Figure 4. Setup Used to Measure Reaction Temperatures.**

The experimental configuration consists of a reaction chamber that can be evacuated and back-filled with an inert gas, a data acquisition system to acquire and process thermocouple readings, and a variable transformer to ignite the powder. Two thermocouples were used in each experiment. They consisted of tungsten (W)-5% rhenium (Re) vs. W-26% Re wires and had an average bead size of 630  $\mu\text{m}$ . The upper temperature limit of these thermocouples is 2,316° C, with short-term exposures of up to 2,760° C. Data were collected over 120 s.

Temperature measurements were carried out to establish the effects of the PTM and of specimen size on the cooling rate. Excessive thermal stresses in the specimens due to high cooling rates were a concern because they can lead to macrocrack formation. Therefore, the cooling rates were measured for compacts using both the  $\text{Al}_2\text{O}_3$ -based and graphite-based PTMs. Figure 5 shows the results of the cooling experiments. For comparison, the cooling profile for no PTM is included. Due to the high exothermicity of the  $\text{Ti} + \text{C} \rightarrow \text{TiC}$  reaction, the peak temperature reached exceeded the

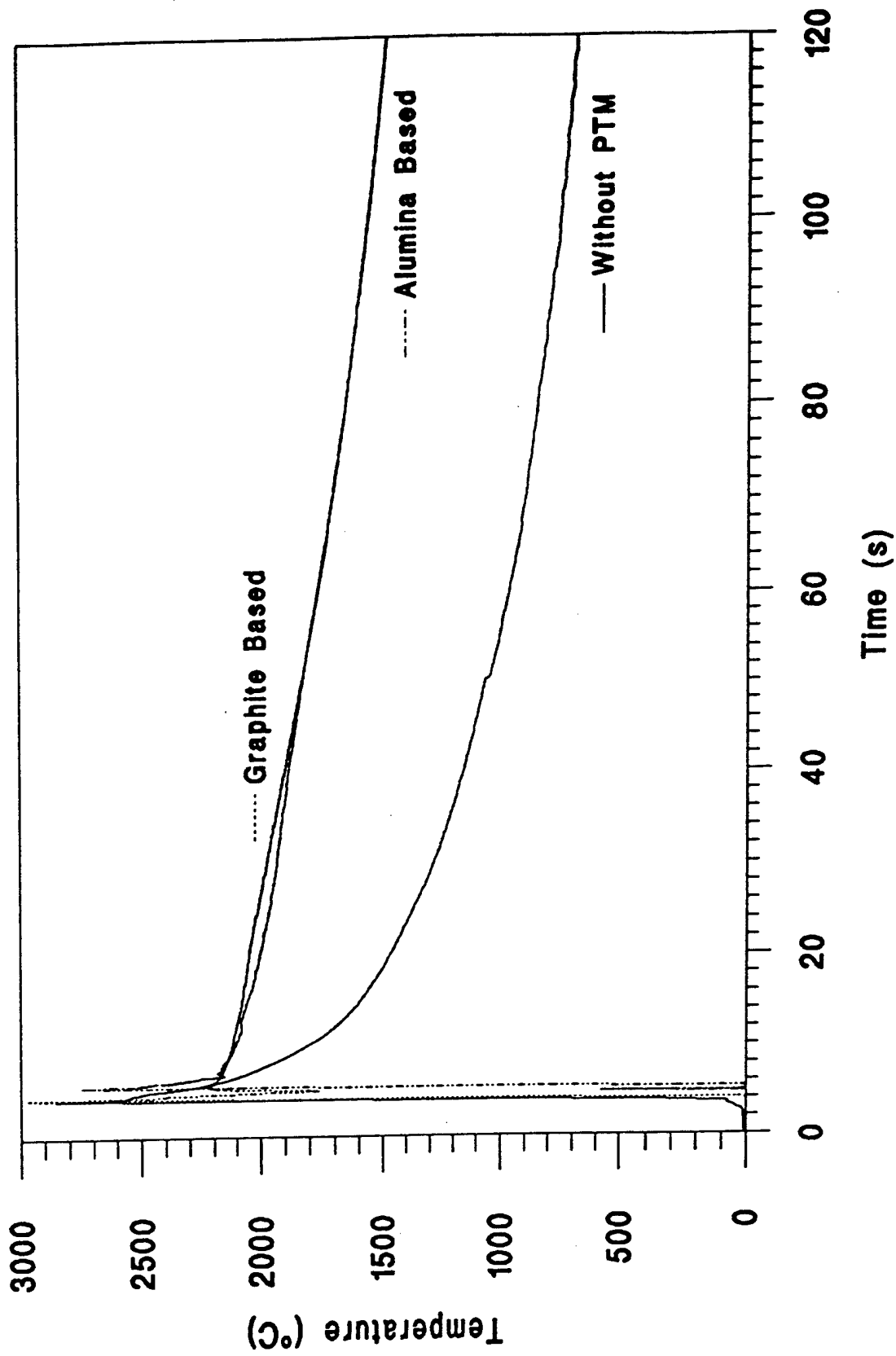
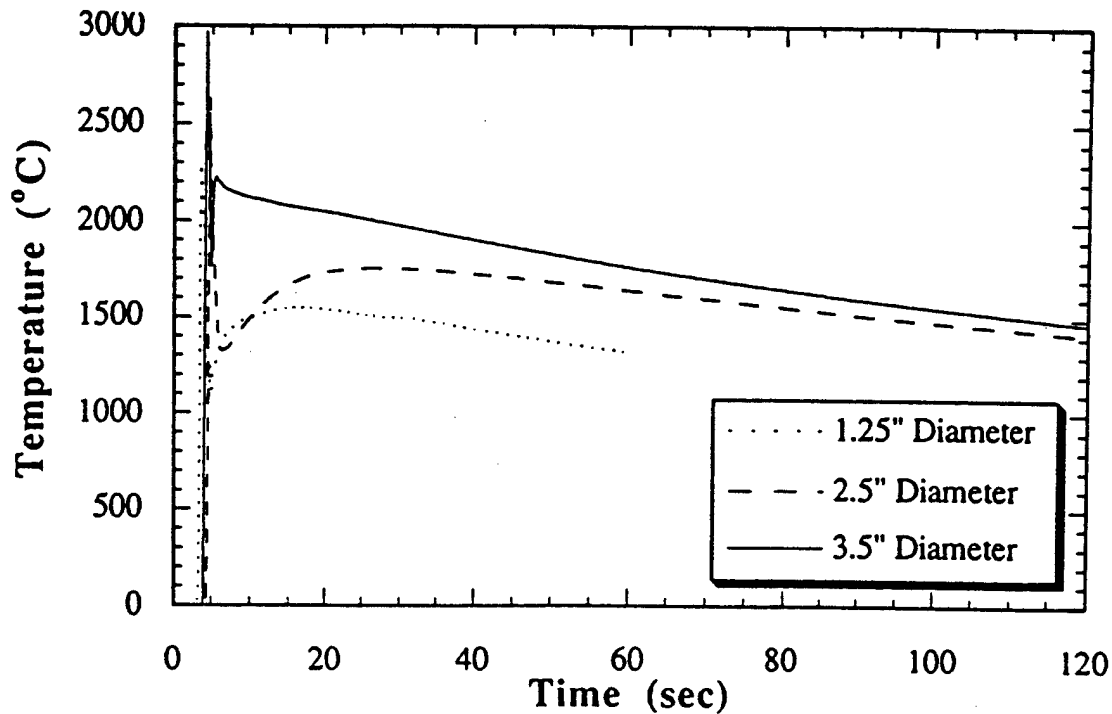

Figure 5. Effect of PTM Type on Cooling Characteristics of CSed TiC.

melting point of the W-Re (or W-rhodium [Rh]) thermocouples ( $\sim 2,800^{\circ}\text{C}$ ). The effect of thermocouple bead melting on the temperature profile can be seen as a drop in the recorded temperature. However, in most cases, the thermocouple bead reformed and solidified when the temperature dropped below its melting point. In Figure 5, the cooling rate in the absence of the PTM is faster than with the PTM. Thus, the PTM serves as effective thermal insulation and provides a means of reducing thermal gradients within the compact.

The size of the compact also affects the cooling rate. Figure 6 shows compacts with 3.2-, 6.4-, and 8.9-cm (1.25, 2.5, and 3.5 in) diameters. Although the signals show discontinuities (due to thermocouple melting), the cooling rate is clearly higher for smaller compacts. This shows that scaling up is an effective means of further decreasing thermal stresses.



**Figure 6. Experimentally Determined Temperature Time Plots for Different Compact Diameters.**

A computer simulation accounting for the cooling behavior of the TiC tiles was generated using a one-dimensional (1-D) (neglecting edge effect [i.e., infinite diameter]) finite-difference heat



transfer program. In Al<sub>2</sub>O<sub>3</sub>-based PTM simulation, the interface between the TiC compact and the PTM was initially set at the melting temperature for Al<sub>2</sub>O<sub>3</sub> (i.e., 2,145° C). It is reasoned that this is the maximum temperature that the Al<sub>2</sub>O<sub>3</sub>-based PTM can reach since any increase above this temperature would require large amounts of additional energy. The thermophysical data were taken from Toth (1971), and Storms (1967), and Weast (1973) and are listed in Table 9. Figure 7 shows the measured and compared cooling curves at the TiC-PTM interface. The correlation between the results is excellent. This correlation served to celebrate the model. The differences in thermal properties between the two PTMs used were not significant. The cooling occurred at approximately the same rate. Figure 8 shows the temperature profiles as a function of time for the Al<sub>2</sub>O<sub>3</sub>-based PTM. The initial temperature gradients in the specimen were very high, and the effect of these temperature gradients in the specimen was also very high.

The effect of temperature gradients on the integrity of the compacts can be assessed by establishing the effect of thermal tensile stresses on existing flaws. One has to assume that flaws are present in the material; it is common to consider existing flaws with a size equal to the grain diameter.

**Table 9. Thermophysical Data Used in Computations**

Material	Density (kg/m <sup>3</sup> )	Thermal Conductivity (W/m • °C)	Specific Heat (J/kg • °C)
Porous TiC	2,500	10.0	950.0
Graphite-Based PTM	1,000 <sup>a</sup>	10.0	500.0
Al <sub>2</sub> O <sub>3</sub> -Based PTM	1,700	5.0	500.0

<sup>a</sup> Measured.

The actuation of flaws results in cracks, and the internal stresses,  $\sigma_{th}$ , can be estimated from the approximate expression

$$\sigma_{th} = E\alpha\Delta T, \quad (1)$$

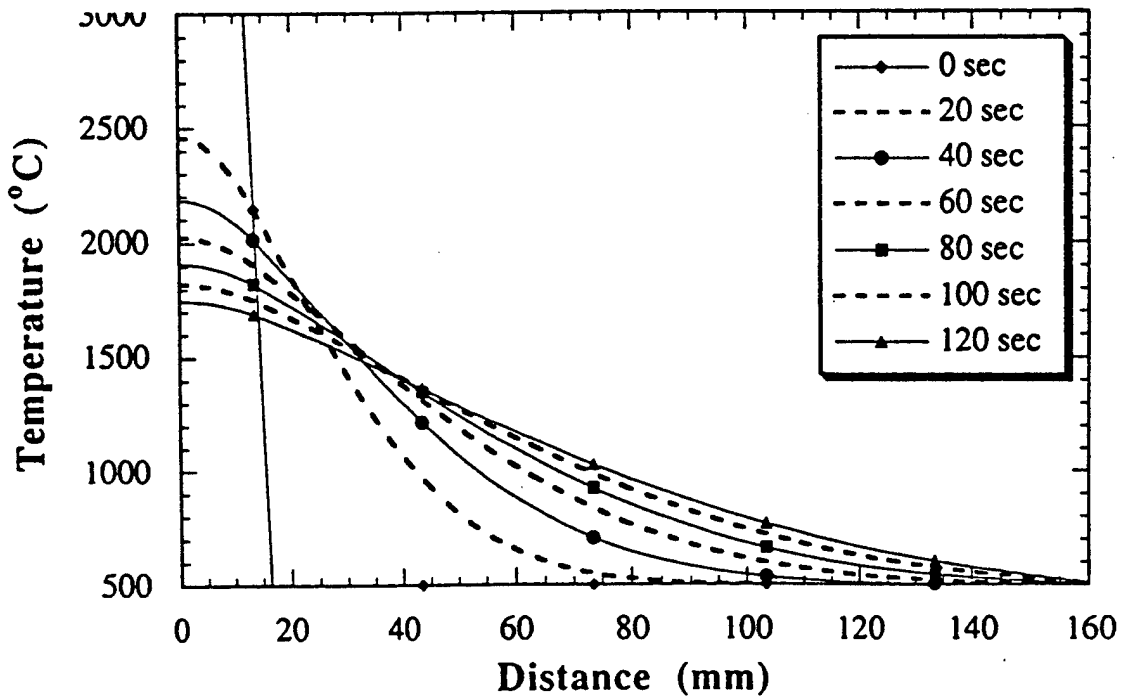
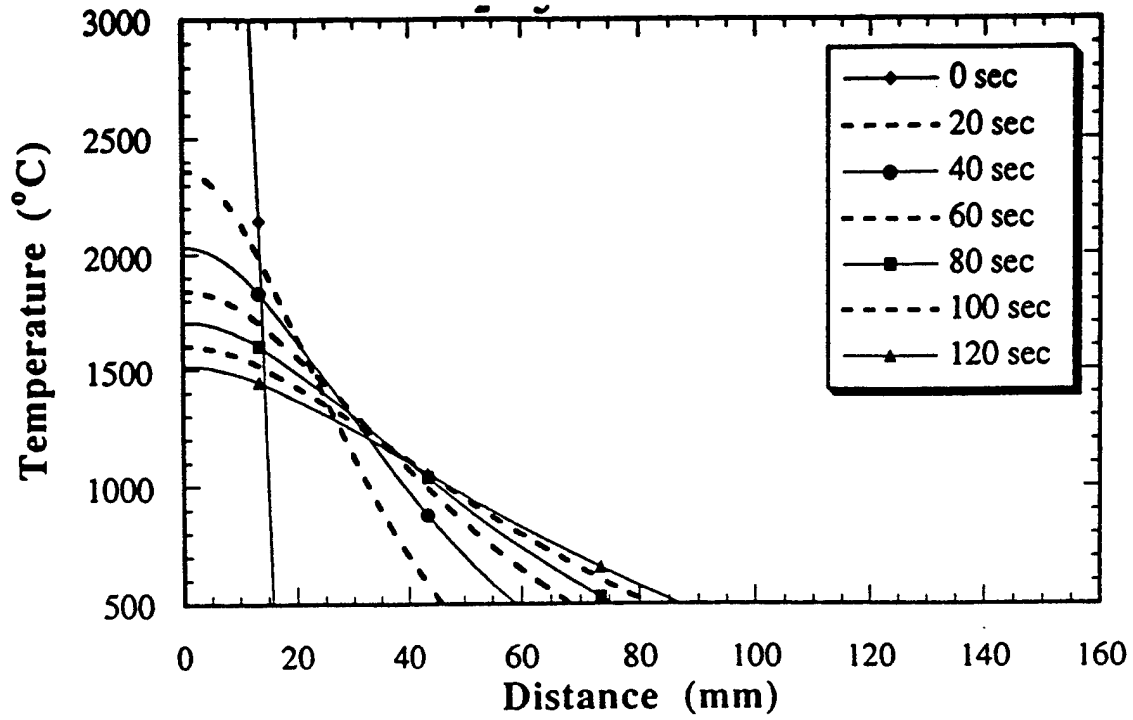

Figure 7. Temperature Distance Plots for Different Times With (a) Al<sub>2</sub>O<sub>3</sub>-Based PTM at Room Temperature and With (b) Al<sub>2</sub>O<sub>3</sub>-Based PTM at 500° C.

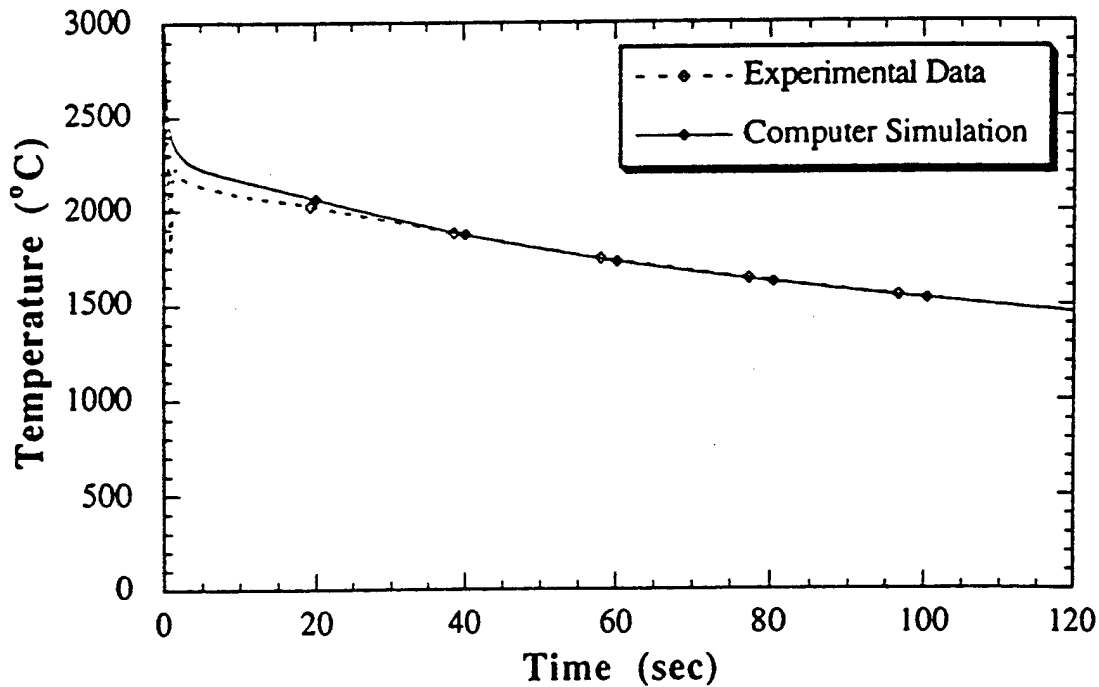
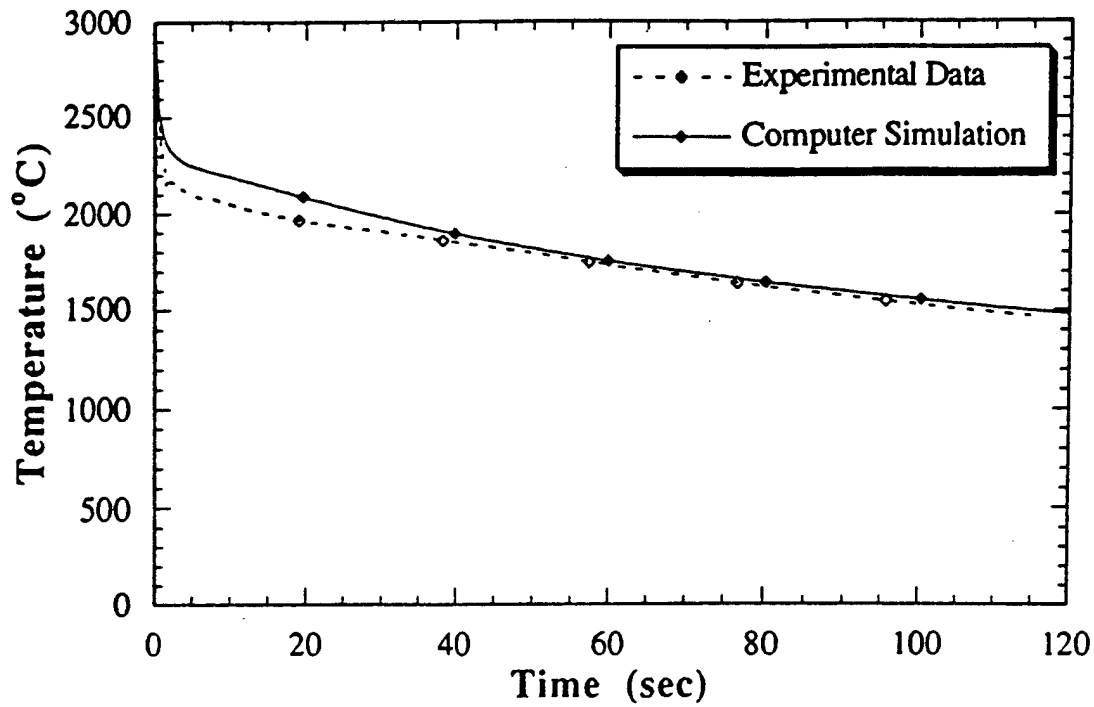

Figure 8. Comparison of Measured and Completed Temperature Histories for (a) Al<sub>2</sub>O<sub>3</sub>-Based PTM and (b) Graphite-Based PTM.

where  $\Delta T$  is the temperature differential,  $\alpha$  is the linear thermal expansion coefficient (equal to  $7.4 \times 10^{-6} \text{ K}^{-1}$  [Cutler, Virkar, and Holt 1985]), and  $E$  is Young's modulus (equal to 400 GPa). From fracture mechanics,

$$K_{IC} = \sigma \sqrt{\pi a}, \quad (2)$$

where  $K_{IC}$  is the fracture toughness, and  $2a$  is the flaw size. Substituting equation (2) into equation (1),

$$\Delta T = \frac{K_{IC}}{E\alpha \sqrt{\pi a}}. \quad (3)$$

Equation (3) gives the maximum allowable temperature differential for a certain flaw size in a material having a fracture toughness  $K_{IC}$ . Assuming that the fracture toughness of TiC is  $3 \text{ MPa} \cdot \text{m}^{1/2}$ , and that flaws of  $200 \text{ } \mu\text{m}$  exist within it (approximate grain size), a temperature gradient of  $57^\circ \text{ C}$  would be sufficient to induce thermal cracking. The existence of thermal gradients at temperatures above the ductile-to-brittle transition temperature (DBTT) does not pose a great problem, since the value of  $K_{IC}$  is much larger above the critical transition ( $1,800^\circ \text{ C}$ ).

Thus, the initial temperature differential (at times  $<120 \text{ s}$ ) is of no great concern. The thermal ignition of the compact by preheated PTM decreases the thermal stresses, as shown in Figure 8. The calculations are conducted for PTM, preheated to a temperature of  $500^\circ \text{ C}$ . The use of a preheated PTM reduces the temperature considerably, and the thermal gradients are significantly less severe. These measurements and calculations show that cooling of the compacts has to be very gradual to avoid large temperature gradients, especially below the DBTT of TiC (i.e., no observations of data before/after). They also explain the decrease in cracking, obtained by using the preheated PTM.

## 7. Characterization

**7.1 Specimen Preparation.** Because of the very high hardness of high-density TiC specimens, significant time and effort were expended in machining specimens for metallographic and microstructural evaluation. The use of electrodischarge machining (EDMing) and diamond grinding was extensively applied to cut, grind, and polish specimens for these characterization tasks.

Specimens for optical metallography were polished and etched in an acid mixture consisting of two parts nitric, one part hydrofluoric, and one part acetic acid. XRD was carried out on a Philips diffractometer, and scanning electron microscopy (SEM) was carried out using a Cambridge unit.

Quasi-static mechanical tests were conducted in compression and flexural loading (four-point bending) on specimens that had been EDMed. The compression specimen had dimensions of 4 mm × 4 mm × 6 mm and was tested at a strain rate of  $4 \times 10^{-4}$ /s between parallel platens. Stainless steel shims with a thickness of 25 μm were used at the specimen platen interfaces, and the compression surfaces of the specimen were polished to 50 μm. The four-point bending tests were carried out on bars with rectangular sections of 4 mm × 4 mm and a length of 30 mm. The external supports were 25.4 mm apart, and the internal loading points were 12.7 mm apart.

**7.2 Microstructural Characterization and Phase Analysis.** XRD of the as-consolidated material reveals very clearly that the reaction product is TiC. The peaks are identified in Figure 9. Co-K<sub>α</sub> radiation was used, and the lattice parameter was calculated to be equal to  $0.433 \pm 0.0078$  nm. The lattice parameter can be correlated to the stoichiometry of the final product. Storms (1967) provides a plot listing data of numerous investigators. The C/Ti atomic ratio varies from 1 to 0.5 (there is a wide homogeneity region for TiC in the phase diagram), and the lattice parameter varies correspondingly, from 0.433 to 0.430 nm. The results displayed in Figure 9 indicate that the C/Ti ratio is 0.9. This is, in essence, the initial composition used in the experiments reported herein. Optical microscopy of sample cross sections (surface perpendicular to major dimensions of disk) revealed an equiaxed grain structure with significant differences in grain size.

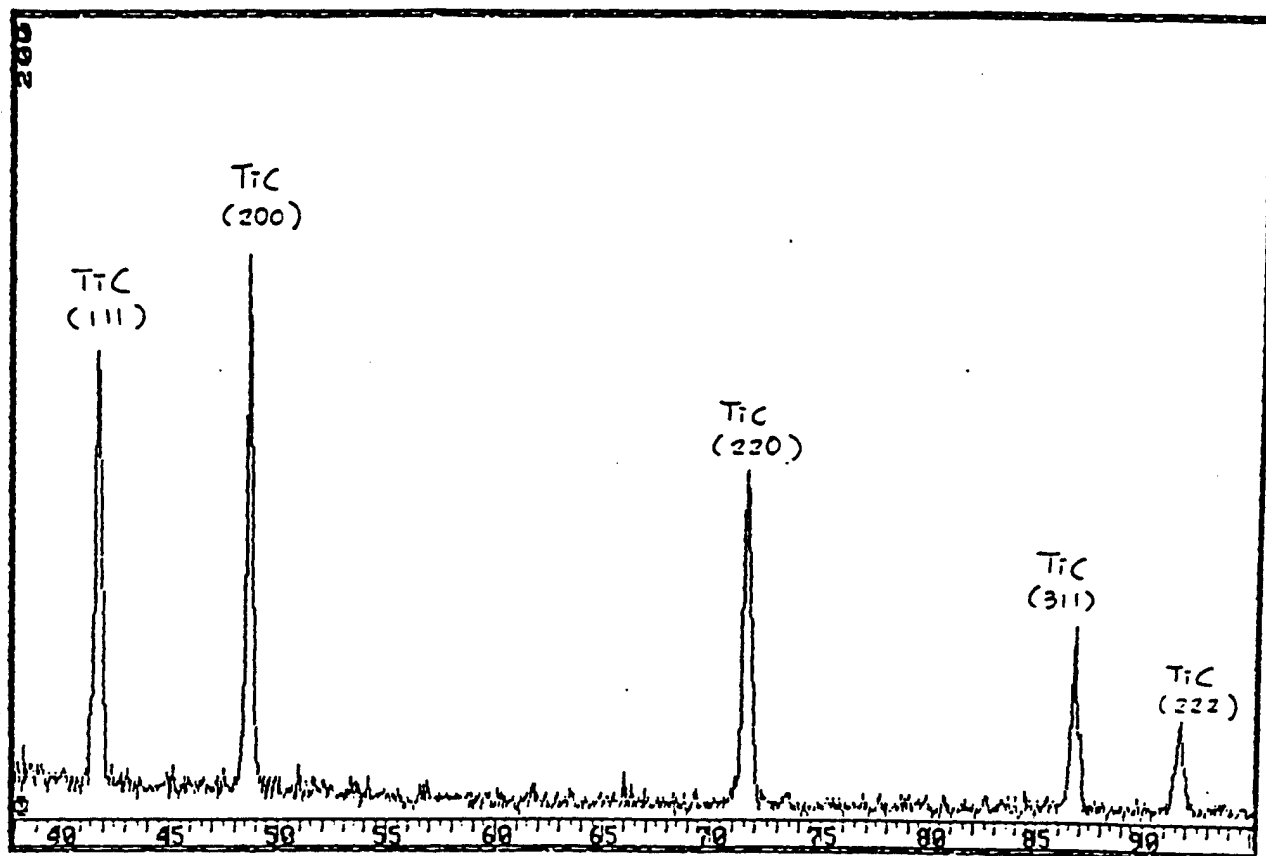

Figure 9. XRD for a 10-cm  $\times$  10-cm Tile (Co-K $_{\alpha}$  Radiation).

The maximum grain size increased with the size of the specimen. Figure 10 shows plots of grain size vs. position along the cross section of the 6.4- and 10.2-cm compacts; the thickness of the compacts are 2 and 2.4 cm, respectively. The grain size variation is clearly evident and is larger for the larger compact due to its slower cooling rates.

### 7.3 Mechanical Properties.

**7.3.1 Microhardness.** The microhardness was measured across and along the cross sections of the specimens. Figure 11 shows the results for the 10.2-cm compact. Four traverses were made at 1.5 mm, 7.0 mm, 14.0 mm, and 19.5 mm from the edge of the 2.5-cm-wide compact. The regions close to the top, bottom, and lateral surfaces display higher hardness values. The hardness within the 2.5-cm-wide compact is correspondingly lower.

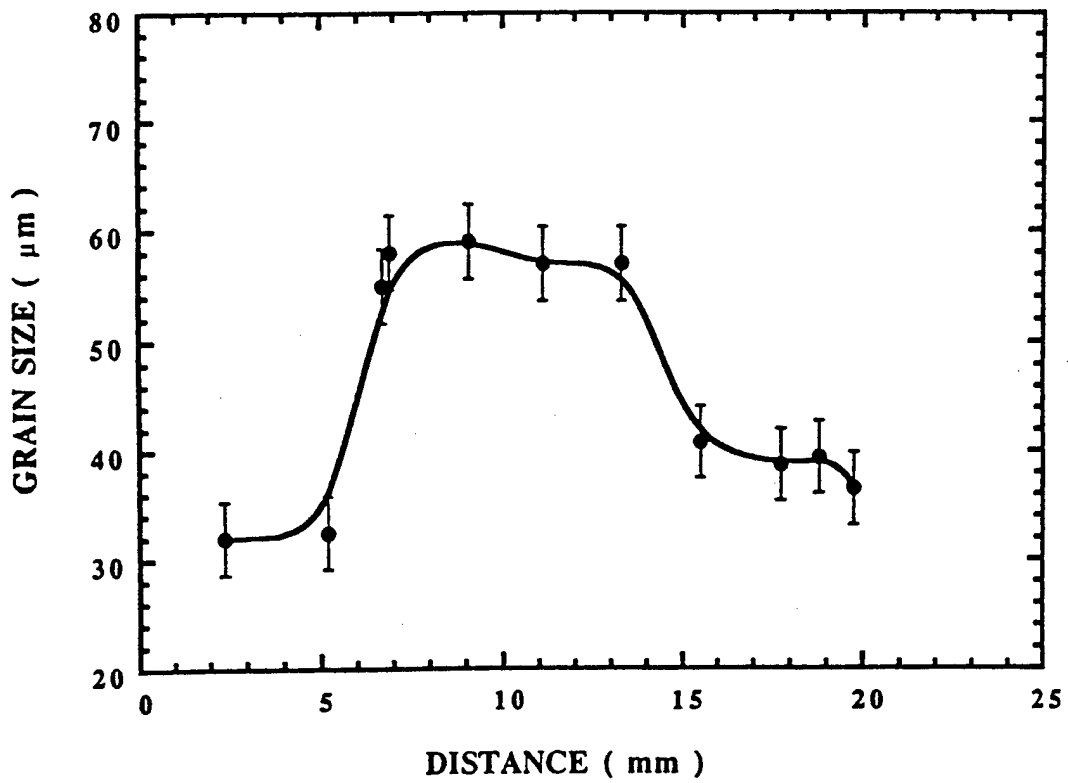
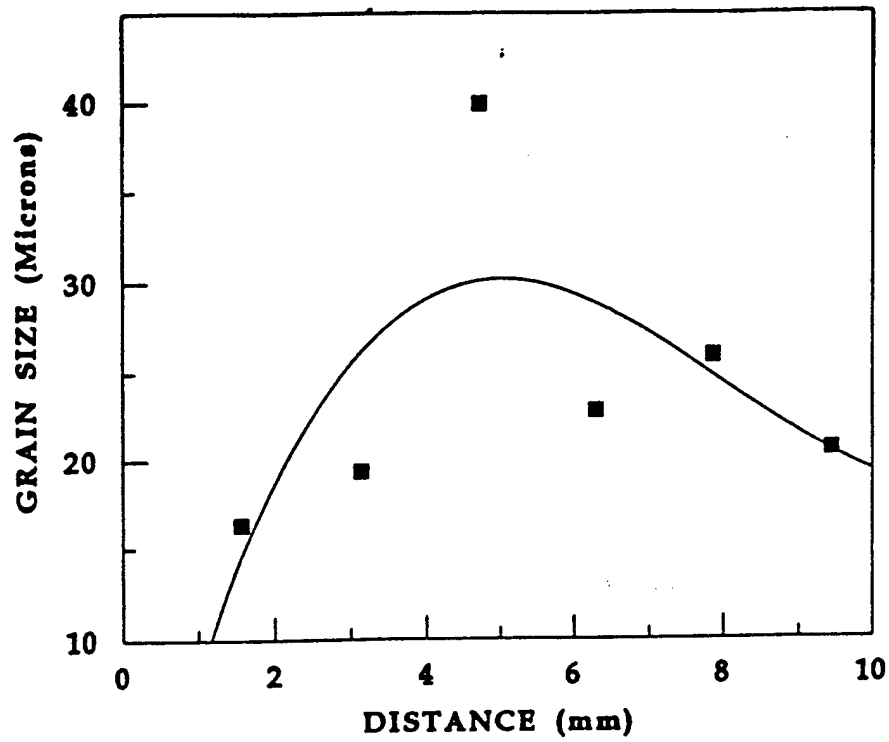
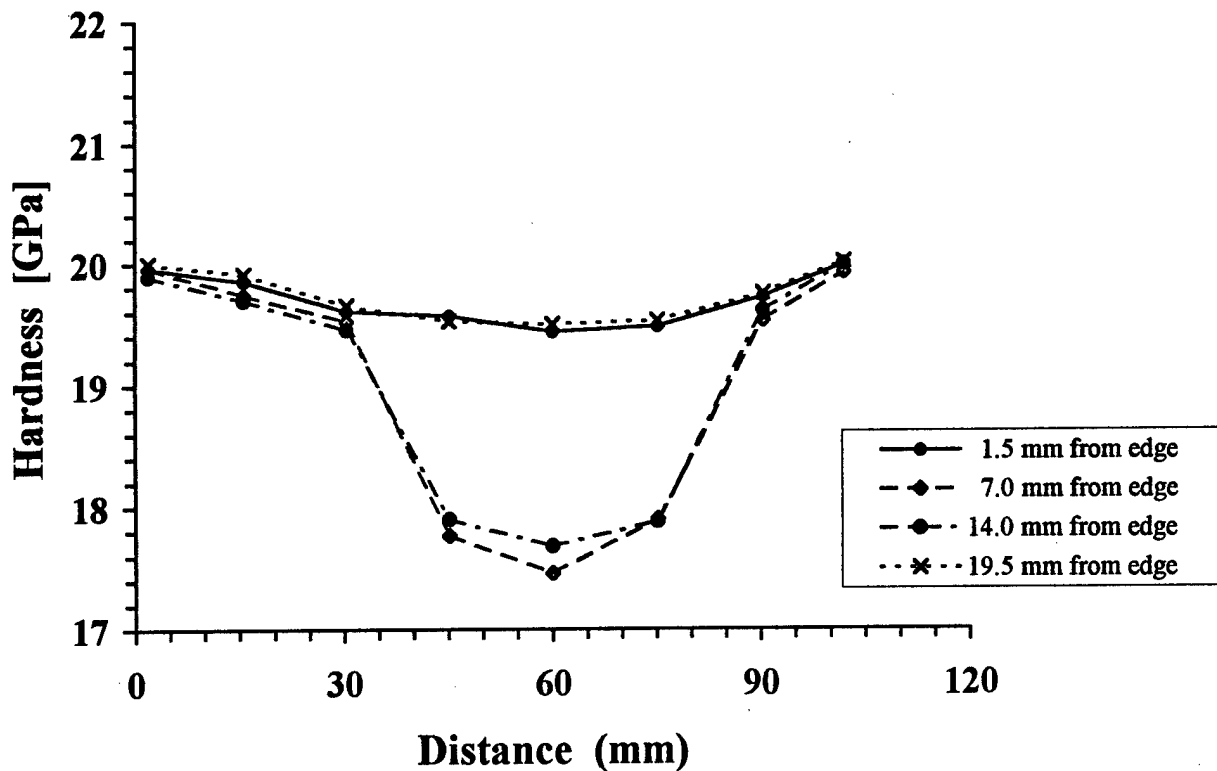

Figure 10. Grain Size vs. Position Along Cross Section for (a) 6.35-cm-Square and (b) 10.2-cm-Square Cross-Sectional TiC Tiles.



**Figure 11. Hardness Traverses Along a 10.2-cm Sample Cross Section.**

**7.3.2 Compression Strength and Modulus of Rupture Strength.** The results of compression tests are shown in Table 10. The average of five tests is 1.79 GPa. Four-point bending tests (flexural tests) yielded a modulus of rupture of 0.166 GPa of 10% of the compressive strength.

The fractures generated in the flexure and compression tests were observed by SEM and are shown in Figure 12. The fractures are primarily transgranular, showing that the grain boundaries are strong and free of impurities. There is no difference between the fracture surfaces of flexure and compression specimens, and the morphology is established by the position of specimen with respect to the compact. Some porosity can be seen in the fracture surfaces. Cleavage facets are also seen, as well as localized regions where some intergranular fracture occurred. The fracture surface close to the surface, on the other hand, exhibited a different morphology. As seen in Figure 13, the grain sizes are much smaller and close to the surface and there is greater porosity. These factors altered the fracture morphology, and Figure 13 shows the resulting surface. A greater tendency for intergranular fracture can be seen.



**Table 10. Compressive Strength of TiC**

Sample	Outside (GPa)	Center (GPa)
1	1.43	1.22
2	1.13	1.28
3	1.11	1.28
4	1.18	1.18
Average Value	1.21 ± 0.148	1.24 ± 0.049

**7.3.3 Fracture Toughness.** Fracture toughness measurements were made by measuring cracks emanating from the indentation produced by a microhardness tester. This technique has been successfully used by many investigators (Evans and Charles 1976) and correlated with fracture toughness measurements made by other techniques. The indentation diagonals,  $2a$ , were equal to 0.02 mm when a Vickers indenter with a load,  $P$ , of 500 gf was used. The average crack size,  $c$ , was 27  $\mu\text{m}$ . The fracture toughness is obtained from

$$\begin{aligned} K_{IC} &= 0.16 H a^2 c^{-3/2} \\ &= 0.16 \times 0.47 P c^{-3/2} \\ K_{IC} &= 2.6 \text{ MPa} \cdot \text{m}^{1/2}. \end{aligned}$$

The value obtained for  $K_{IC}$  is characteristic of a well-bonded ceramic.

**7.3.4 Elastic Modulus.** The compressive elastic modulus was measured indirectly through deflection of the specimens as required in the recorder (correcting for machine stiffness). The values of Young's modulus shown in Table 11 are quite lower than those for fully compacted and flawless

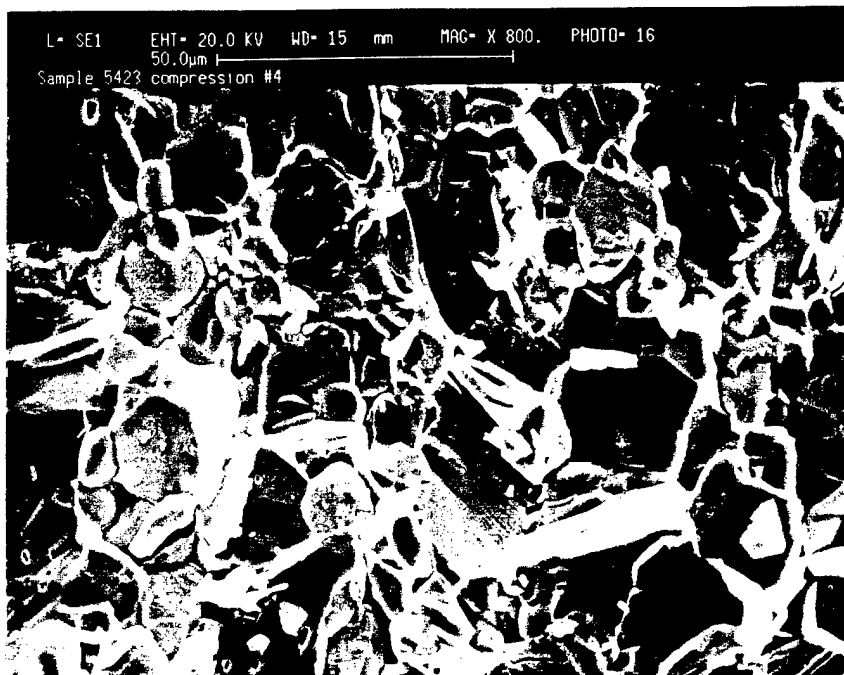
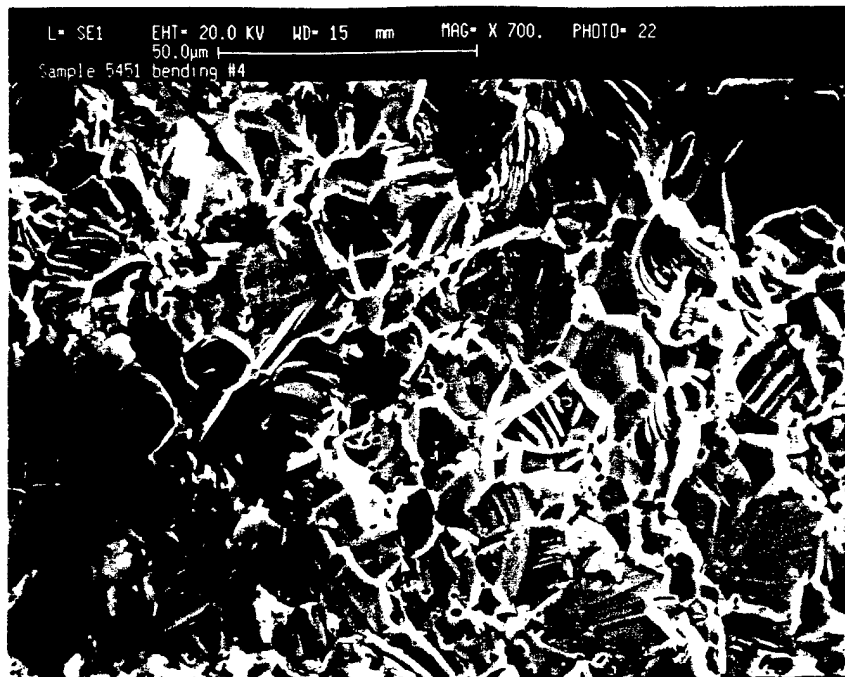

**Figure 12. Fracture Surfaces in (a) Flexure and (b) Compression Specimens.**

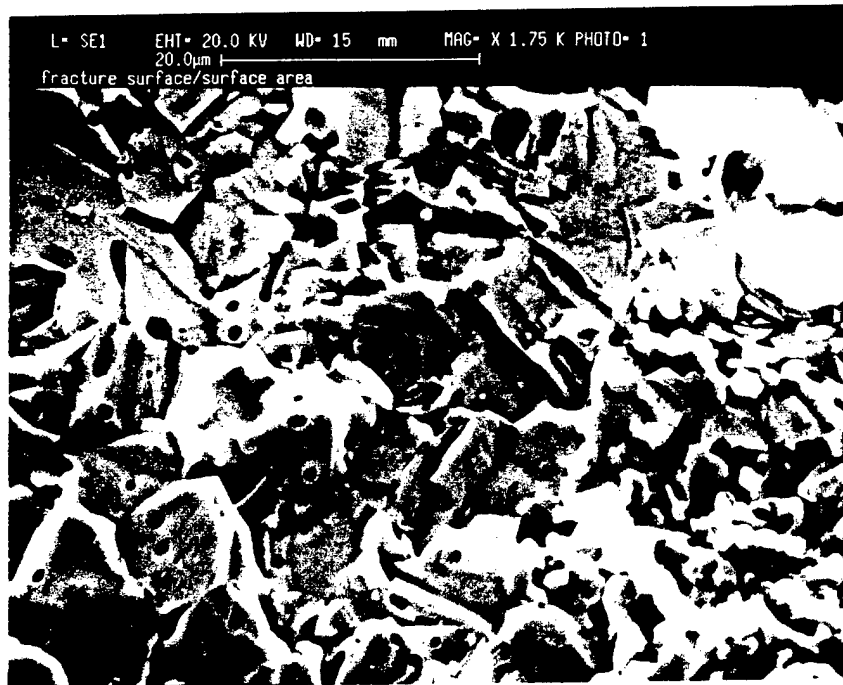

**Figure 13. Fracture Surface Close to the Specimen Surface.**

**Table 11. Young's Modulus of TiC**

Specimen	Young's Modulus (GPa)
1	164.2
2	98
3	120

material. Young's modulus of the latter material varies between 400–500 GPa, while the values measured fluctuate from 98 to 164 GPa. The differences are possibly partially due to the presence of the lubricant between the platens. Nevertheless, it is known that cracks and pores affect Young's modulus.

**7.3.5 Dynamic Mechanical Properties.** Five specimens of CS/CF TiC were machined for compressive strength measurements using a Hopkinson bar. The Hopkinson bar tests were carried

out at the Aeronautical Laboratories of the California Institute of Technology. The experiments were conducted at a nominal strain rate of 1,000/s. The dynamic compressive strength of the material was measured to be  $2 \text{ GPa} \pm 200 \text{ MPa}$ .

## 8. Machining of CS/CF Tiles

Several machining options were explored in order to find the most economical and least damaging (crack-inducing) method to machine the final  $15\text{-cm} \times 15\text{-cm} \times 2.5\text{-cm}$  tile from the CS/CF part. These included:

- ceramic cutting and grinding,
- EDM machining, and
- water-jet cutting.

Tiles measuring  $10.2 \times 10.2 \times 1.9 \text{ cm}$  were provided to service houses experienced in each of the discussed cutting techniques.

**8.1 Ceramic Machining and Grinding.** Ceramic machining and grinding using diamond wheels and blades proved to be the most economical route with the least amount of grinding damage and a step that could be incorporated in the production mode. Bomas Machine Specialties in Somerville, MA, optimized the grinding and machined all the final  $15\text{-cm} \times 15\text{-cm} \times 2.5\text{-cm}$  tiles. However, some edge defects were noticed, especially when the grinding/cutting blade exited the tile. A photograph showing machine tiles is provided in Figure 14.

**8.2 EDM.** EDM was found to be very competitive with ceramic grinding. Of the several EDM houses looked into, AccuCut, proved to be the place most suitable for the finishing operation. However, some tiles had a small amount of  $\text{Al}_2\text{O}_3$  (coming from the PTM) remaining behind, which

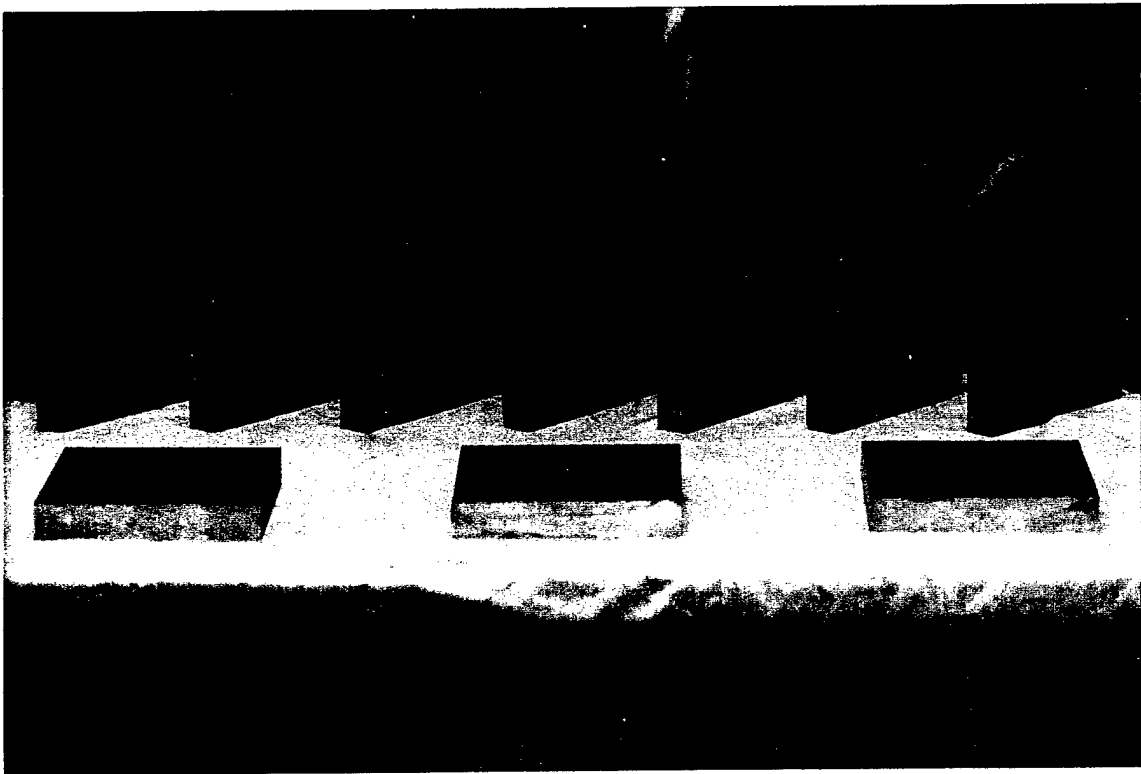

**Figure 14. CS/CF 15-cm × 15-cm × 2.5-cm TiC Tiles.**

would pose problems to the EDM process. Also, EDM for such small runs was more expensive and more time consuming than conventional grinding.

**8.3 Water-Jet Cutting.** Water-jet cutting was found to be the most expensive of the three routes explored, and serious doubts were expressed by the service houses themselves regarding large-scale manufacturing using this technology.

## **9. Cost Model to Manufacture**

A cost model to manufacture has been provided in Appendix C.

## 10. Phase II Accomplishments

- A new one-step synthesis-densification process that allows for the fabrication of 95% dense, mostly crack-free TiC for armor application was successfully developed and demonstrated.
- This process allows for the fabrication of crack-free TiC tiles of size 15 cm × 15 cm × 2.5 cm.
- A cost analysis of this process based on prototype quantities processed using this technology shows that the cost to manufacture TiC armor tiles using this process is ~60% less than current costs for the U.S. Army to procure this material.
- The results of this work were presented to an international audience working in the area of CS.
- Modeling work to elucidate the thermal management required in the process was carried out in collaboration with a university.
- Extensive characterization work to identify grain size, compressive strength, modulus, modulus of rupture, fracture toughness, and microhardness was carried out.
- It was also found that the same process makes commercially useful intermetallic compounds such as TiAl, NiAl, and MoSi<sub>2</sub> from elemental compounds.

## 11. Recommendations for Phase III

Ceracon has demonstrated the feasibility of a low-cost process to make dense 15-cm × 15-cm × 2.5-cm tiles for armor applications. Prototype quantities of these tiles have been fabricated and delivered to ARL for evaluation. Ceracon recommends the following.

- ARL should provide non-SBIR funding in Phase III to further upscale this low-cost process for a larger volume of ceramic tiles of interest to the Army.
- ARL should provide support in the form of a Letter of Interest and matching funds in this technology to Ceracon so that additional sources for funding, such as the Advanced Technology Program and Technology Reinvestment projects, can be approached for dual-use applications of this technology.
- ARL can also play a role in helping to further leverage research and development (R&D) in this area by facilitating cooperative R&D with the former Soviet Union under the Department of Defense and Department of State programs.
- Commercial opportunities in the area of cutting tools, heating elements, automotive parts, and wear products shall be pursued using this technology.

## 12. References

- Adachi, S., T. Wada, T. Mihara, M. Koizumi, and O. Yamada. "Fabrication of Titanium Carbide Ceramics by High-Pressure Self-Combustion Sintering of Titanium Powder and Carbon Fiber." *Journal of the American Ceramics Society*, vol. 72, no. 5, pp. 805–809, May 1989.
- Borom, M. P., and M. Lee. "Effect of Heating Rate on Densification of Alumina-Titanium Carbide Composites." *Advanced Ceramic Materials*, vol. 1, no. 4, p. 335–341, April 1986.
- Borovinskaya, I. P., E. A. Levashov, and A. S. Rogachev. "Physical, Chemical, and Technological Base of SHS." Course of Lectures, The National Education USSR State Committee, Institute of Structural Macrokinetics, USSR Academy of Sciences and Moscow Steel and Alloys Institute, Moscow, USSR, 1991.
- Cutler, R. A., A. V. Virkar, and J. B. Holt. "Synthesis and Densification of Oxide-Carbide Composites." *Ceramic Engineering & Science Proceedings*, vol. 6, no. 7–8, pp. 715–728, July–August 1985.
- Dunmead, S. D., Z. A. Munir, and J. B. Holt. "Temperature Profile Analysis in Combustion Synthesis: I. Theory and Background." *Journal of the American Ceramics Society*, vol. 75, no. 1, pp. 175–179, January 1992.
- Evans, A. G., and E. A. Charles. "Fracture Toughness Determination by Indentation." *Journal of American Ceramics Society*, vol. 59, no. 7–8, pp. 371–372, July–August 1976.
- Grebe, H. A., A. Advani, N. H. Thadhani, and T. Kottke. "Combustion Synthesis and Subsequent Explosive Densification of Titanium Carbide." *Metallurgical Transactions A*, vol. 23A, no. 9, pt. 2, pp. 2365–2372, September 1992.
- Hoke, D. A., M. A. Meyers, L. W. Meyers, and G. T. Gray. "Reaction Synthesis/Dynamic Compaction of Titanium Diboride." *Metallurgical Transactions A*, vol. 23A, no. 1, pt. 1, pp. 77–86, January 1992.
- Holt, J. B., and Z. A. Munir. "Combustion Synthesis of Titanium Carbide: Theory and Experiment." *Journal of Material Sciences*, vol. 21, no. 2, pp. 251–259, February 1986.
- Kecskes, L. J.; and A. Niiler. "Impurities in the Combustion Synthesis of Titanium Carbide." *Journal of the American Ceramic Society*, vol. 72, no. 4, pp. 655–661, April 1989.
- Kecskes, L. J., A. Niiler, and T. Kottke. "Microstructural Properties of Combustion-Synthesized and Dynamically Consolidated Titanium Boride and Titanium Carbide." *Journal of the American Ceramic Society*, vol. 73, no. 5, pp. 1274–1282, May 1990.



- Kim, Y. W., and J. G. Lee. "Pressureless Sintering of Alumina-Titanium Carbide Composites." *Journal of the American Ceramic Society*, vol. 72, no. 8, pp. 1333-1337, August 1989.
- LaSalvia, J. C. "Production of Dense Titanium Carbide by Combining Reaction Synthesis With Dynamic Compaction." M.S. Thesis, University of California at San Diego, La Jolla, CA, 1990.
- LaSalvia, J. C., L. W. Meyer, and M. A. Meyers. "Densification of Reaction-Synthesized Titanium Carbide by High-Velocity Forging." *Journal of the American Ceramic Society*, vol. 75, no. 3, pp. 592-602, March 1992.
- Lichti, W. P., and A. F. Hofstatter. "Method of Object Consolidation Employing Graphite Particulate." U.S. Patent No. 4,539,175, September 1985.
- Merzhanov, A. G. "Self-Propagating High-Temperature Synthesis: Twenty Years of Search and Findings." *Combustion and Plasma Synthesis of High-Temperature Materials*, pp. 1-53, Z. A. Munir and J. B. Holt (editors), VCH Publishers, New York, NY, 1990.
- Merzhanov, A. G., and I. P. Borovinskaya. "Self Propagated High Temperature Synthesis of Refractory Inorganic Compounds." *Doklady Akademii Nauk SSSR (In Russian)*, vol. 204, no. 2, pp. 366-369, May 1972; *Doklady Chemistry (English translation)*, vol. 204, no. 2, pp. 429-432, May 1972.
- Meyers, M. A., J. C. LaSalvia, D. Hoke, J. M. Jamet, and D. K. Kim. "Combustion Synthesis Densification of Ceramics and Ceramic Composites." *Proceedings of the International Conference on Advanced Synthesis of Engineering Structural Materials*, pp. 43-57, American Society for Materials International, Materials Park, OH, 1993.
- Miyamoto, Y., and M. Koizumi. "Simultaneous Synthesis and Densification of Ceramic Components Under Gas Pressure by SHS." *Combustion and Plasma-Synthesis of High-Temperature Materials*, pp. 163-169, Z. A. Munir and J. B. Holt (editors), VCH Publishers, New York, NY, 1990.
- Molokov, I. V., and A. S. Mukasyan. "Explosive Treatment of SHS Gas-Solid Systems." *International Journal of Self-Propagating High-Temperature Synthesis*, vol. 1, no. 1, pp. 155-159, January 1992.
- Munir, Z. A. "Synthesis of High-Temperature Materials by Self-Propagating Combustion Methods." *Ceramic Bulletin*, vol. 67, no. 2, pp. 342-349, February 1988.
- Niiler, A., L. J. Kecskes, and T. Kottke. "Shock Consolidation of Combustion Synthesized Ceramics." *Combustion and Plasma-Synthesis of High-Temperature Materials*, pp. 309-314, Z. A. Munir and J. B. Holt (editors), VCH Publishers, Inc., New York, NY, 1990.

- Niiler, A., L. J. Kecskes, and T. Kottke. "Explosive Compaction Processing of Combustion Synthesized Ceramics and Cermets." *Shock-Wave and High-Strain-Rate Phenomena in Materials*, pp. 293–301, M. A. Meyers, L. E. Murr, and K. P. Staudhammer (editors), Marcel Dekker, Inc., New York, NY, 1992.
- Niiler, A., L. J. Kecskes, T. Kottke, P. H. Netherwood, Jr., and R. F. Benck. "Explosive Consolidation of Combustion Synthesized Ceramics: TiC and TiB<sub>2</sub>." BRL-TR-2951, U.S. Army Ballistic Research Laboratory, Aberdeen Proving Ground, MD, December 1988.
- Rabin, B. H., G. E. Korth, and R. L. Williamson. "Fabrication of Titanium Carbide-Alumina Composites by Combustion Synthesis and Subsequent Dynamic Consolidation." *Journal of the American Ceramic Society*, vol. 73, no. 7, pp. 2156–2157, July 1990.
- Raman, R. V. "A Novel Manufacturing Process Route for Forming High Density Ceramic Armor Materials." Phase I Final Report, DAAA 15-01-C-0087, U.S. Army Ballistic Research Laboratory, Aberdeen Proving Ground, MD, to be published.
- Raman, R. V., and A. Niiler. Personal communication. U.S. Army Ballistic Research Laboratory, Aberdeen Proving Ground, MD, November 1991.
- Raman, R. V., and S. V. Rele. "A Novel Processing Route for the Fabrication of Monolithic and Composite Silicon Nitride." *Silicon Nitride Ceramics*, vol. 287, pp. 309–313, I. W. Chen, P. F. Becher, M. Mitomo, G. Petzow, and T. S. Yen (editors), Materials Research Society, Pittsburgh, PA, 1993.
- Raman, R. V., S. V. Rele, and D. Kapoor. "Solid State Densification of Tungsten Heavy Alloys at Low Temperatures and High Pressures." *Advances in Powder Metallurgy and Particulate Materials*, vol. 2, pp. 421–429, J. M. Capus and R. M. German (editors), Metal Powder Industries Federation, Princeton, NJ, 1992.
- Rice, R. W. "Assessment of the Application of SPS and Related Reaction Processing to Produce Dense Ceramics." *Ceramic Engineering and Science Proceedings*, vol. 11, nos. 9–10, pp. 1203–1225, September–October 1990.
- Riley, M. A., and A. Niiler. "Low Pressure Compaction of SHS Prepared Ceramics." BRL-MR-3574, U.S. Army Ballistic Research Laboratory, Aberdeen Proving Ground, MD, March 1987.
- Shikhverdiev, R. M., R. R. Kudashev, O. Yu. Efimov, N. G. Zaripov, and Yu. A. Gordopolov. "Shock Wave Effects in the Ti-C SHS System." *International Journal of Self-Propagating High-Temperature Synthesis*, vol. 1, no. 1, pp. 64–66, January 1992.
- Storms, E. K. *The Refractory Carbides*. New York, NY: Academic Press, p. 8, 1967.
- Toth, L. E. *Transition Metal Carbides and Nitrides*. New York, NY: Academic Press, p. 6, 1971.

- Vecchio, K. S., J. C. LaSalvia, M. A. Meyers, and G. T. Gray. "Microstructural Characterization of Self-Propagating High Temperature Synthesis/Dynamically Compacted and Hot-Pressed Titanium Carbides." *Metallurgical Transactions A*, vol. 23A, no. 1, pt. 1, pp. 87-97, January 1992.
- Von Erlich, P. "Ueber die Binaren Systeme des Titans mit den Elementen Stickstoff, Kohlenstoff, Bor und Beryllium." *Zeitschrift fur Anorganische Chemie*, vol. 259, nos. 1-4, pp. 1-41, SUSPENSE: July 1949.
- Weast, R. C. *Handbook of Chemistry and Physics*. 54th edition, CRC Press, Cleveland, OH, 1973.
- Yamada, O., Y. Miyamoto, and M. Koizumi. "High-Pressure Self-Combustion Sintering of Titanium Carbide." *Journal of the American Ceramic Society*, vol. 70, no. 9, pp. C206-C208, September 1987.
- Yi, H. C., and J. J. Moore. "Self-Propagating High-Temperature (Combustion) Synthesis (SHS) of Powder-Compacted Materials." *Journal of Material Science*, vol. 25, no. 2B, pp. 1159-1168, February 1990.

## **Appendix A:**

**Process Conditions for 55 TiC Tiles Having  
Approximate Dimensions 5 cm × 5 cm × 2 cm  
and 10 TiC Tiles Having Approximate Dimensions  
10 cm × 10 cm × 2.5 cm**

INTENTIONALLY LEFT BLANK.

**Table A-1. Process Conditions for 5-cm x 5-cm x 2-cm TiC Tiles**

Ceracon No.	CIP (MPa)	Grafoil (mm)	Ti	TiC (% wt.)	Green Preform			PTM Type	PTM Temp. (°C)	Part Temp. (°C)	Die Temp. (°C)	Hold Time (hr:min)	Ign. Time (min:sec)	Forge Press. (x10 <sup>3</sup> TPa)	Strain Rate	Bleed Rate (%)	Cooling (°C)	Post-Ceracon			Theor. Density (%)
					Height (cm)	Width (cm)	Length (cm)											Height (cm)	Width (cm)	Length (cm)	
5111	172	NA	?	0	1.727	5.994	5.994	9400	1200	20	41	NA	1:41	3.10	60	Fast	1,200	—	—	—	?
5112	172	NA	?	0	2.383	5.240	4.923	9400	1200	20	130	NA	3:35	3.10	60	Fast	1,200	—	—	—	85.2
5113	172	NA	?	0	1.430	6.325	2.870	9400	1200	20	130	NA	?	3.10	100%	Fast	1,200	—	—	—	?
5114	172	NA	?	0	1.430	5.080	5.080	9400	1200	20	130	NA	3:43	1.79	100%	100	1,200	—	—	—	90.0
5115	172	NA	?	0	1.430	5.080	5.080	A-75	1200	20	132	NA	4:13	1.79	100%	100	In Die	—	—	—	93.9
5117	69	NA	?	0	1.905	5.080	5.080	A-75	1200	20	136	NA	3:11	1.79	100%	100	1,100	—	—	—	91.5
5118	69	NA	?	0	1.588	5.240	5.240	A-20	1400	20	136	NA	0:48	1.79	100%	100	1,100	—	—	—	88.9
5158	69	NA	B	0	2.235	3.505	5.232	A-75	1200	20	53	NA	0:38	1.79	100%	100	1,100	—	—	—	96.0
5159	69	NA	B	0	2.235	3.505	4.928	A-75	1200	20	115	NA	3:59	1.79	100%	100	1,100	—	—	—	97.6
5160	69	NA	B	0	2.057	3.505	5.410	A-75	1200	20	146	NA	4:05	1.79	100%	100	1,100	—	—	—	97.8
5161	69	NA	B	0	2.388	4.597	5.715	A-75	1200	20	146	NA	7:49	1.79	100%	100	1,100	—	—	—	90.4
5162	69	NA	B	0	2.106	4.694	4.681	A-75	1212	20	30	NA	5:01	1.79	60	100	1,200	—	—	—	95.3
5163	69	NA	B	0	2.329	4.201	5.479	A-75	1203	20	53	NA	5:37	1.79	60	100	1,100	—	—	—	95.3
5164	69	NA	B	0	2.055	5.039	5.568	A-20	1203	20	111	NA	5:51	1.79	100%	100	1,100	—	—	—	—
5165	69	NA	B	0	2.421	4.849	4.943	A-8	1202	20	138	NA	NA	NA	NA	NA	NA	NA	NA	NA	?
5166	69	NA	B	0	2.286	4.686	5.834	A-8	1210	20	130	NA	NA	NA	NA	NA	NA	NA	NA	NA	?
5167	69	NA	B	0	1.974	4.295	5.433	A-20	1211	20	130	NA	5:39	1.79	100%	100	1,200	—	—	—	95.1
5334	69	?	?	0	1.321	4.813	5.060	A-20	1400	20	20	0:30	?	1.79	100%	100	Verm.	—	—	—	?
5335	69	NA	?	0	1.323	5.032	5.156	A-20	1400	20	20	1:00	?	1.79	100%	Fast	Verm.	—	—	—	?
5336	69	NA	?	0	1.387	5.113	5.123	A-20	1400	20	20	0:30	?	1.79	100%	Fast	Verm.	—	—	—	?
5337	69	?	?	0	1.382	5.812	5.580	A-20	1400	20	Warm	NA	NA	NA	NA	NA	NA	NA	NA	NA	?
5338	69	NA	?	0	1.280	5.138	5.123	4335	1400	20	20	NA	?	1.79	100%	100	Verm.	—	—	—	?
5339	69	NA	?	0	2.080	5.202	5.100	9400	1197	20	Warm	NA	NA	NA	NA	NA	NA	NA	NA	NA	?
5340	69	?	?	0	—	—	—	9400	1203	20	20	NA	?	1.79	100%	100	Verm.	—	—	—	?
5341	69	NA	?	0	1.588	5.08	5.08	A-20	1231	20	20	NA	?	1.79	100%	Fast	Verm.	—	—	—	?

Notes: CIP = cold isostatic press.  
 PTM = pressure-transmitting medium.  
 Verm. = vermiculite.  
 B = fine.

Table A-1. Process Conditions for 5-cm x 5-cm x 2-cm TIC Tiles (continued)

Carcon No.	CIP (MPa)	Grafoil (mm)	Ti	TIC (% wt.)	Green Preform			PTM Type	PTM Temp. (°C)	Part Temp. (°C)	Die Temp. (°C)	Hold Time (hr:min)	Ign. Time (min:sec)	Forge Press ( $\times 10^3$ TPa)	Strain Rate (%)	Bleed Rate (%)	Cooling (°C)	Post-Carcon			Theor. Density (%)
					Height (cm)	Width (cm)	Length (cm)											Height (cm)	Width (cm)	Length (cm)	
5342	69	NA	?	0	—	—	—	A-20	1400	20	20	NA	?	1.79	100%	100	Verm.	—	—	—	?
5343	241	NA	?	0	—	—	—	A-4	1400	20	20	NA	NA	NA	NA	NA	NA	NA	NA	NA	?
5344	69	NA	?	0	1.689	5.072	4.826	A-20	1231	20	20	NA	?	1.79	100%	100	Verm.	—	—	—	?
5345	69	NA	?	0	1.689	5.067	5.067	A-20	1400	20	20	NA	?	1.79	100%	100	Verm.	—	—	—	?
5346	69	NA	?	0	—	—	—	A-20	1200	20	20	NA	?	1.79	100%	100	Verm.	—	—	—	?
5347	20	NA	?	0	—	—	—	A-20	1400	20	20	NA	?	1.79	100%	100	Verm.	—	—	—	?
5397	69	0.38	B	0	1.905	5.08	5.08	A-20	1208	705	250	0:25	4:00	2.41	100%	100	Verm.	—	—	—	96.5
5396	69	NA	C	0	1.753	4.826	5.08	4335	1213	705	250	0:30	?	2.41	100%	100	Verm.	—	—	—	96.0
5399	69	0.38	B	0	1.918	5.088	5.090	A-20	1212	701	250	0:17	?	2.41	100%	100	Verm.	—	—	—	96.2
5400	69	0.38	B	0	1.913	5.085	5.093	A-20	1213	699	250	0:20	?	2.41	100%	100	Verm.	—	—	—	96.3
5401	69	0.38	B	0	1.918	5.088	5.090	A-20	1212	802	250	0:45	4:05	2.41	100%	100	Verm.	—	—	—	95.7
5402	69	0.64	C	0	1.539	4.834	4.928	A-20	1212	797	250	2:37	3:45	2.41	100%	100	Verm.	—	—	—	95.8
5403	69	0.64	C	0	1.529	5.278	5.283	A-20	1213	800	250	3:38	3:36	2.41	100%	100	Verm.	—	—	—	95.9
5404	69	0.64	C	0	1.910	5.354	5.499	A-20	1208	801	250	1:08	5:45	2.41	100%	100	Verm.	1.140	5.857	5.959	94.9
5405	69	0.64	C	0	1.887	5.639	5.809	A-20	1208	798	250	1:04	5:20	2.41	100%	100	Verm.	1.158	5.855	5.918	96.2
5413	69	0.38	C	0	1.824	5.367	5.436	A-20	1208	707	250	0:41	3:57	2.41	100%	100	Verm.	1.148	5.817	5.921	95.2
5414	69	0.38	C	0	1.875	5.392	5.481	A-20	1208	703	250	0:31	4:49	2.41	100%	100	Verm.	1.247	6.015	6.083	95.9
5415	69	0.38	B	0	1.961	5.174	5.461	A-20	1209	698	250	0:46	4:17	2.41	100%	100	Verm.	—	—	—	93.2
5416	69	0.38	B	0	1.941	5.245	5.263	A-20	1209	690	250	1:25	5:28	2.41	100%	100	Verm.	—	—	—	95.9
5429	69	0.38	B	15	1.963	5.207	5.217	A-20	1201	800	250	NA	NA	NA	NA	NA	NA	NA	NA	NA	?
5430	69	0.38	B	25	1.796	5.116	5.164	A-20	1221	721	250	0:34	NA	NA	NA	NA	NA	NA	NA	NA	?
5431	69	0.38	B	20	1.839	5.057	5.011	A-20	1260	805	250	1:45	NA	NA	NA	NA	NA	NA	NA	NA	?
5432	69	0.38	B	10	2.019	5.194	5.326	A-20	1307	701	250	0:35	NA	NA	NA	NA	NA	NA	NA	NA	?
5423	69	0.38	B	5	2.012	5.212	5.334	A-20	1201	705	250	0:53	4:45	2.41	100%	100	Verm.	1.143	5.464	5.593	95.6
5424	69	0.38	B	15	1.986	5.293	5.326	A-20	1315	701	250	0:25	3:23	2.41	100%	100	Verm.	1.219	5.690	5.702	94.9

Notes: CIP = cold isostatic press.  
 PTM = pressure-transmitting medium.  
 Verm. = vermiculite.  
 B = fine.  
 C = coarse.  
 NA = not applicable.

**Table A-1. Process Conditions for 5-cm x 5-cm x 2-cm TIC Tiles (continued)**

Ceracon No.	CIP (MPa)	Grafoil (mm)	Ti	TIC (% wt.)	Green Preform			PTM Type	PTM Temp. (°C)	Part Temp. (°C)	Die Temp. (°C)	Hold Time (hr:min)	Ign. Time (min:sec)	Forge Press (x10 <sup>3</sup> TPa)	Strain Rate	Bleed Rate (%)	Cooling (°C)	Post-Ceracon			Theor. Density (%)
					Height (cm)	Width (cm)	Length (cm)											Height (cm)	Width (cm)	Length (cm)	
5425	69	0.38	B	20	1.875	5.070	5.093	A-20	1313	699	250	0:40	4:43	2.41	100%	100	Verm.	1.156	5.334	5.362	94.3
5426	69	0.38	B	5	1.836	4.938	5.141	A-20	1306	701	250	0:38	3:28	2.41	100%	100	Verm.	1.247	5.174	5.489	94.4
5427	69	0.38	B	25	1.478	5.189	5.202	A-20	1307	701	250	0:29	3:28	2.41	100%	100	Verm.	1.186	5.565	5.629	92.3
5348	69	NA	?	0	1.588	5.080	5.080	A-20	1203	20	20	?	?	3.10	100%	Fast	Verm.	—	—	—	?
5428	69	0.38	B	10	1.915	4.973	5.344	A-20	1201	700	250	0:38	NA	NA	NA	NA	NA	NA	NA	NA	?

Notes: CIP = cold isostatic press.  
 PTM = pressure-transmitting medium.  
 Verm. = vermiculite.  
 B = fine.



**Table A-2. Process Conditions for 10-cm x 10-cm x 2.5-cm TIC Tiles**

Cencon No.	CIP (MPa)	Grafoil (mm)	Ti	TIC (% wt.)	Green Preform			PTM Type	PTM Temp. (°C)	Part Temp. (°C)	Die Temp. (°C)	Hold Time (hr:min)	Ign. Time (min:sec)	Forge Press ( $\times 10^3$ TPa)	Strain Rate	Bleed Rate (%)	Cooling	Post-Cencon			Theor. Density (%)
					Height (cm)	Width (cm)	Length (cm)											Height (cm)	Width (cm)	Length (cm)	
5417	69	0.38	C	0	4.856	10.185	10.193	A-20	1200	700	250	1:00	6:58	2.41	2,160	100	Verm.	2.875	10.211	10.478	?
5418	69	0.38	C	0	4.018	10.206	10.244	A-20	1200	700	250	1:45	7:22	2.41	2,160	100	Verm.	2.756	10.584	10.782	?
5419	69	0.38	B	0	3.983	9.911	10.254	A-20	1200	700	250	0:45	6:46	2.41	2,160	100	Verm.	2.639	10.871	11.019	?
5420	69	0.38	B	0	3.416	10.081	10.119	A-20	1200	700	250	1:30	6:40	2.41	2,160	100	Verm.	2.311	10.312	10.853	?
5451	69	0.38	B	5	3.754	9.782	9.716	A-20	1200	705	85	0:36	14:20	2.41	100%	100	Verm.	2.131	10.437	10.401	94.3
5452	69	0.38	B	10	3.703	9.987	9.825	A-20	1198	713	73	0:19	12:45	2.41	100%	100	Verm.	2.197	10.874	10.660	?
5453	69	0.38	B	15	3.757	9.538	9.467	A-20	1197	700	73	2:20	9:20	2.41	100%	100	Verm.	2.085	10.904	10.389	?
5454	69	0.38	B	20	3.576	9.657	9.566	A-20	1198	700	100	1:21	9:21	2.41	100%	100	Verm.	2.169	11.308	10.287	?
5455	69	0.38	B	25	3.571	9.421	9.342	A-20	1207	709	80	1:30	12:30	2.41	100%	100	Verm.	2.106	9.898	9.893	?
5456	69	0.38	B	20	4.531	9.675	9.660	A-20	1197	709	75	1:24	7:14	2.41	100%	100	Verm.	2.388	10.546	9.736	?

Notes: CIP = cold isostatic press.  
 PTM = pressure-transmitting medium.  
 Verm. = vermiculite.  
 B = fine.  
 C = coarse.

**Appendix B:**  
**Drawings of the Cold Press, Ceracon Die, and UCIP Die**

INTENTIONALLY LEFT BLANK.

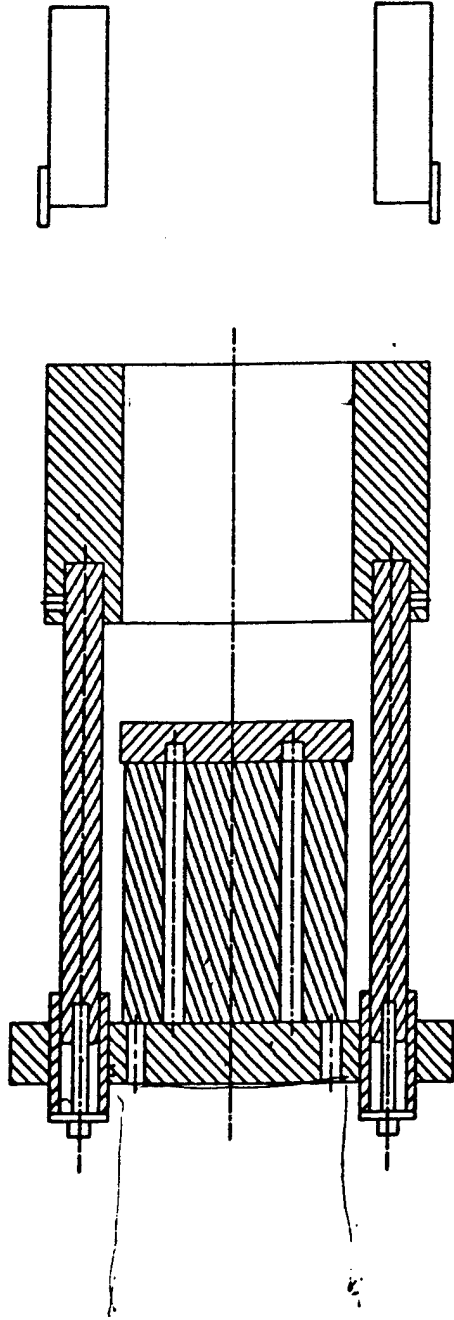

MATERIAL:	CONTRACT,	(916)-928-1933	1181 MARKET BLVD SUITE 9 SACRAMENTO, CA
TOLERANCE UNLESS OTHERWISE NOTED	RS2012	CERACON INC. 95834	
.XXX ±.005	.XX ±.015	TIC COLD PRESS ASSEMBLY	
PART/DRW NUMBER:	10832-10	ENG	
		BRIAN 8-23-83	

Figure B-1. Titanium Carbide (TiC) Cold Press Assembly.

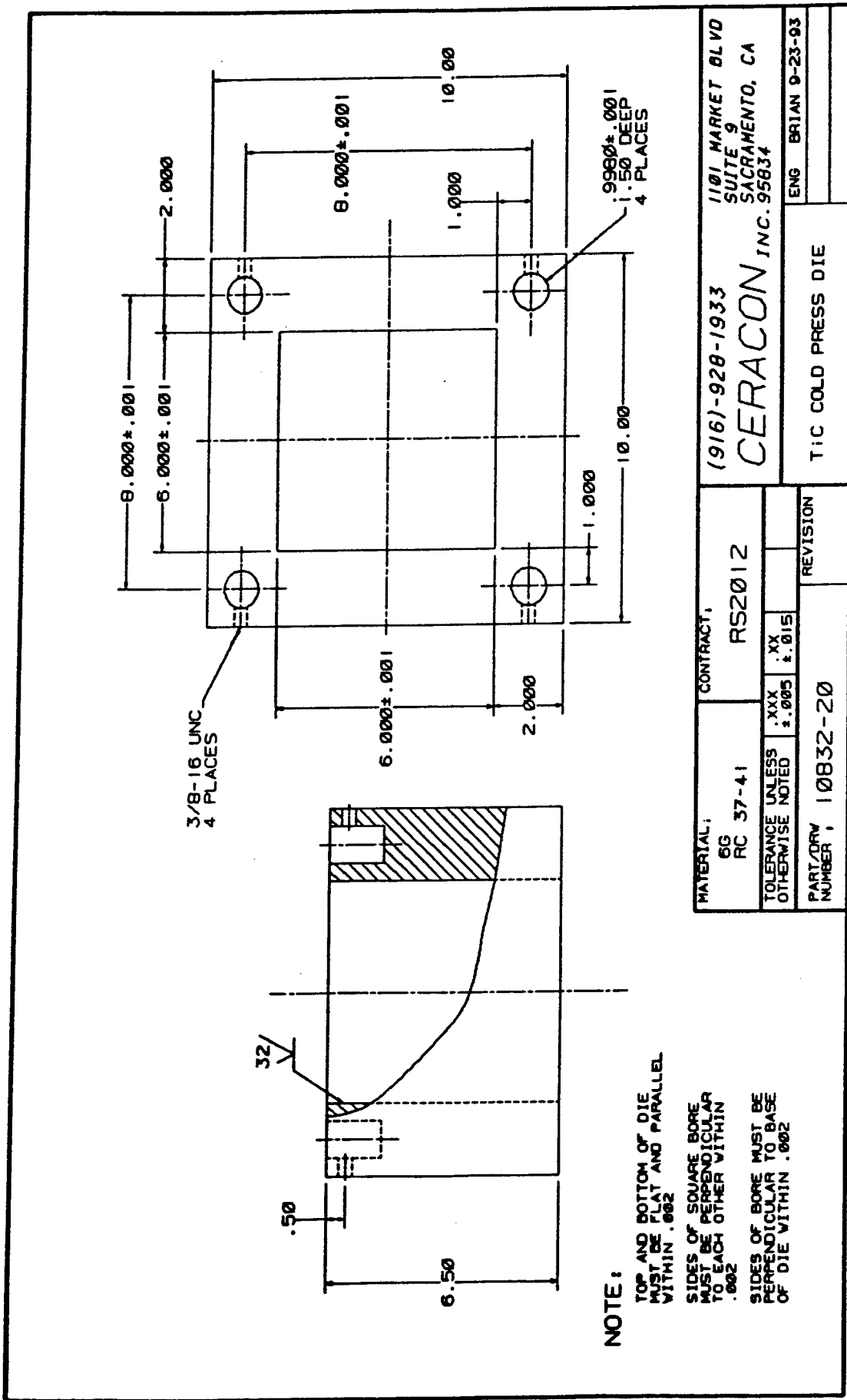

Figure B-2. TIC Cold Press Die.

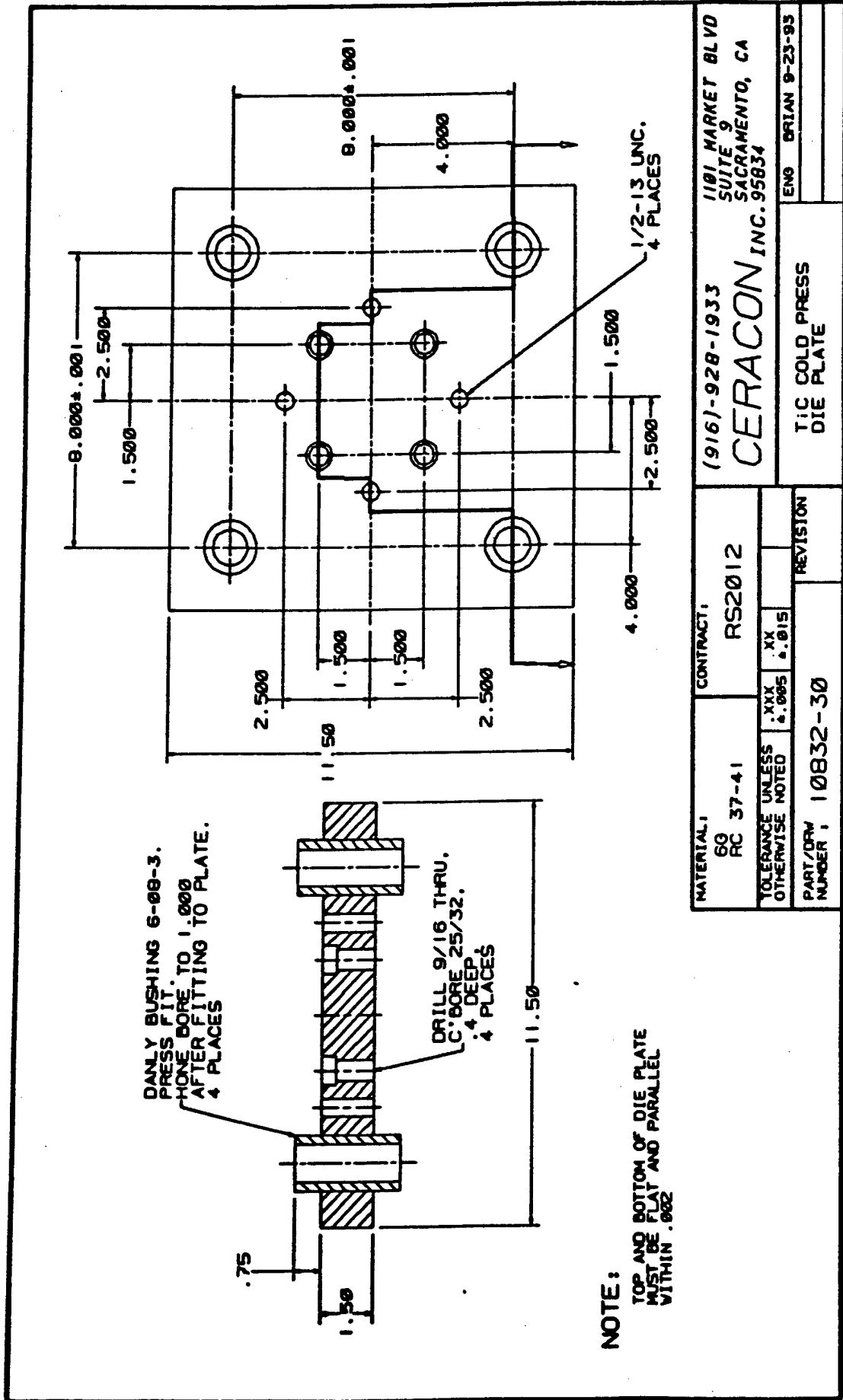

Figure B-3. TIC Cold Press Die Plate.

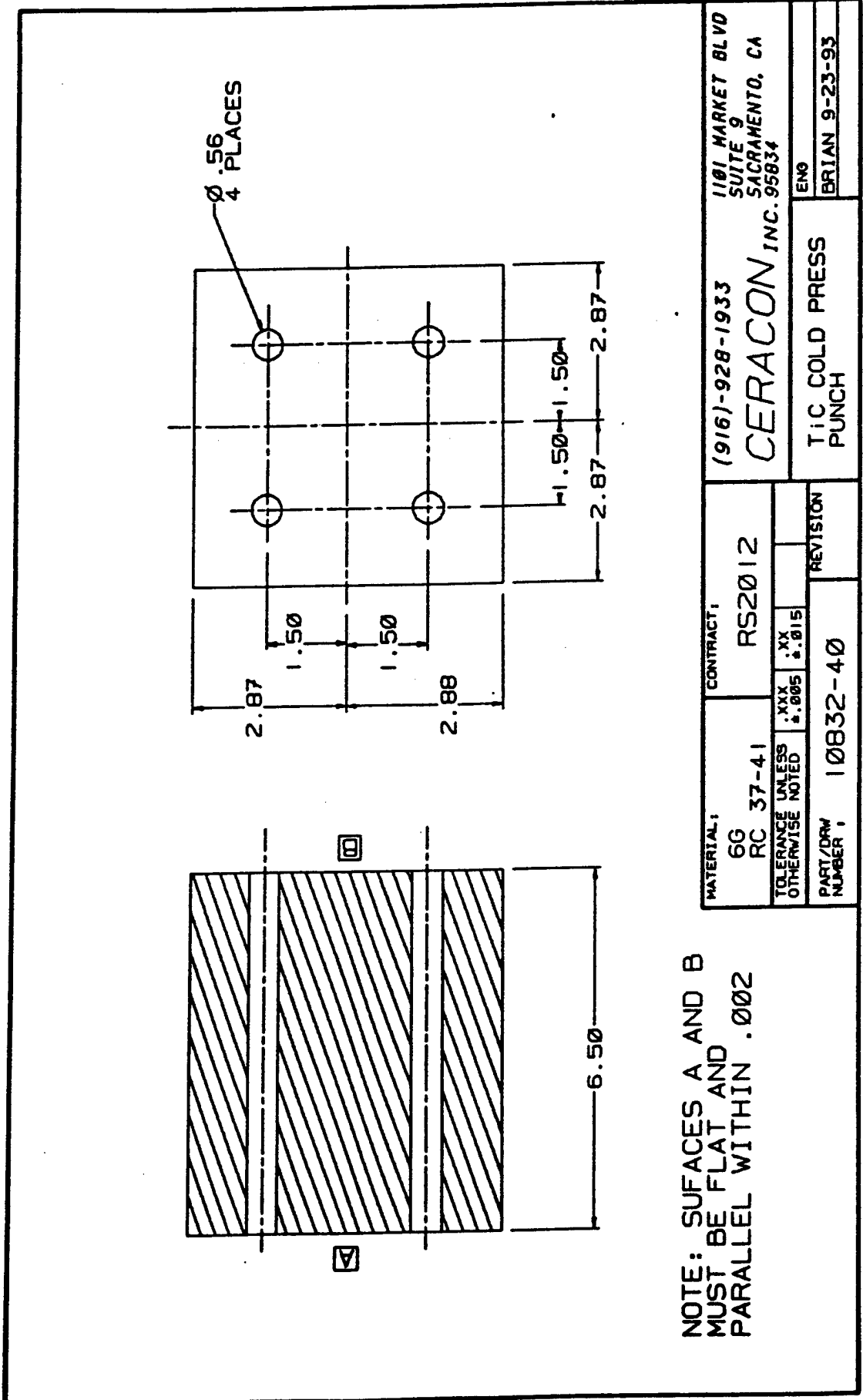

Figure B-4. TiC Cold Press Punch.

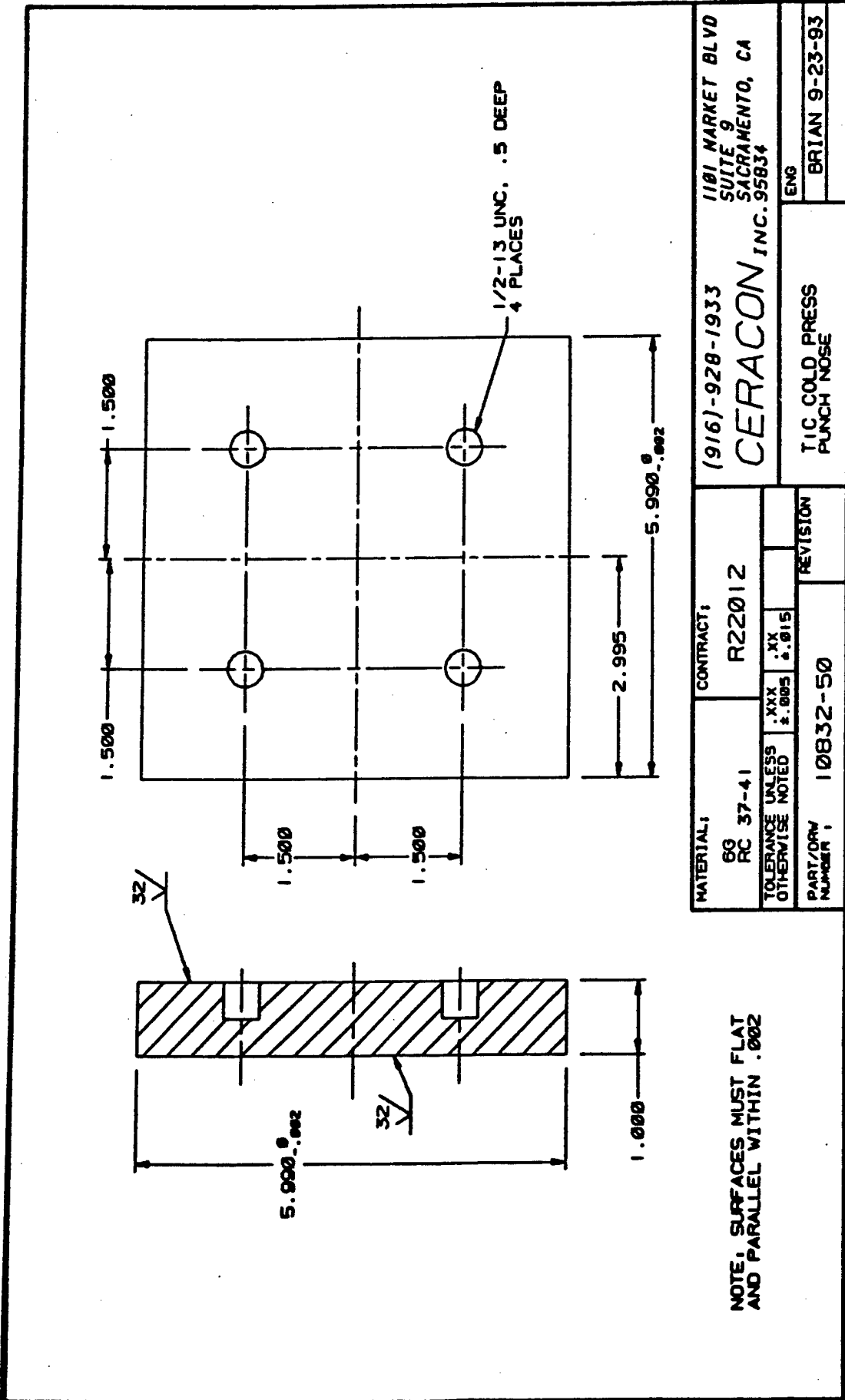

Figure B-5. TIC Cold Press Punch Nose.



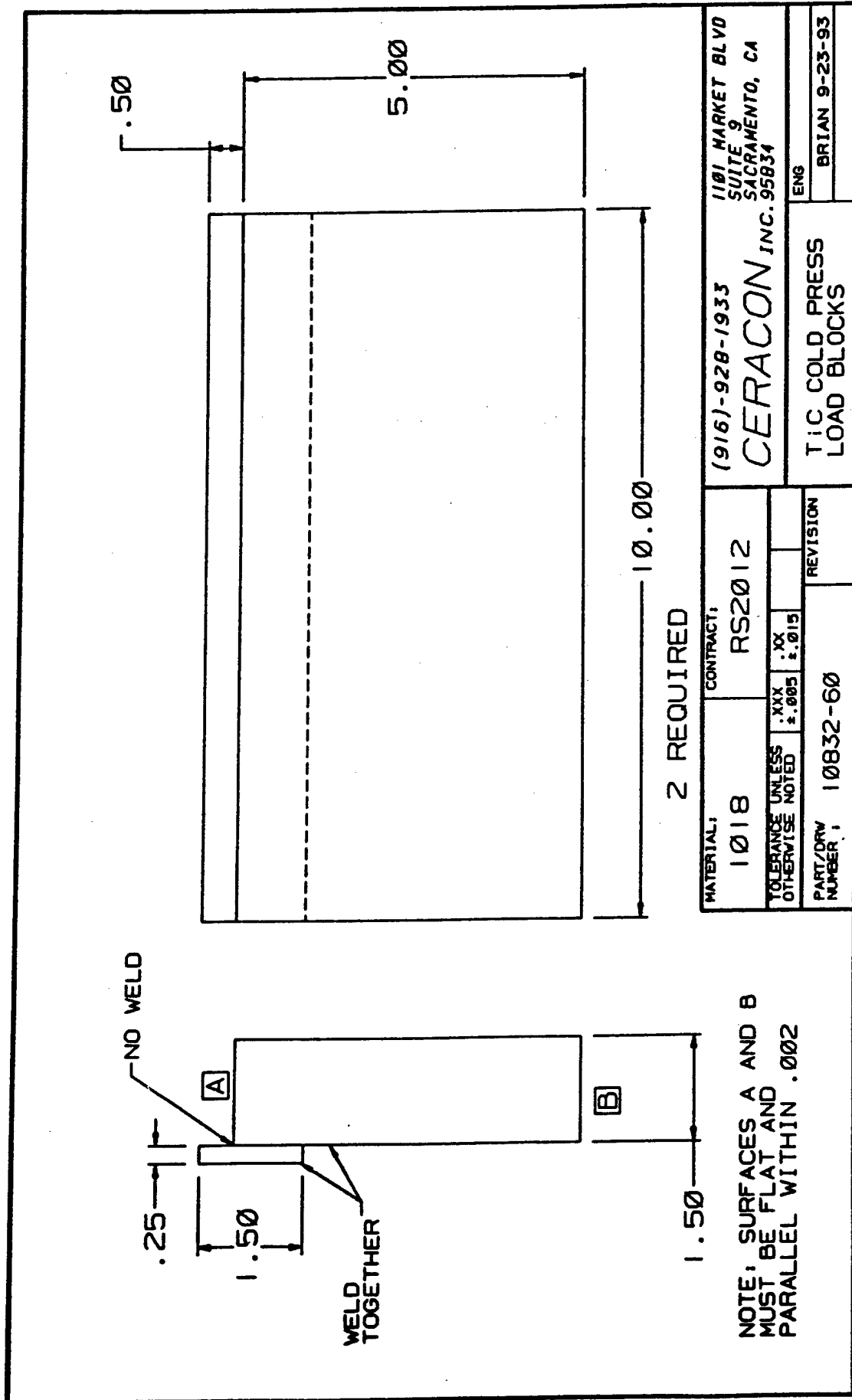
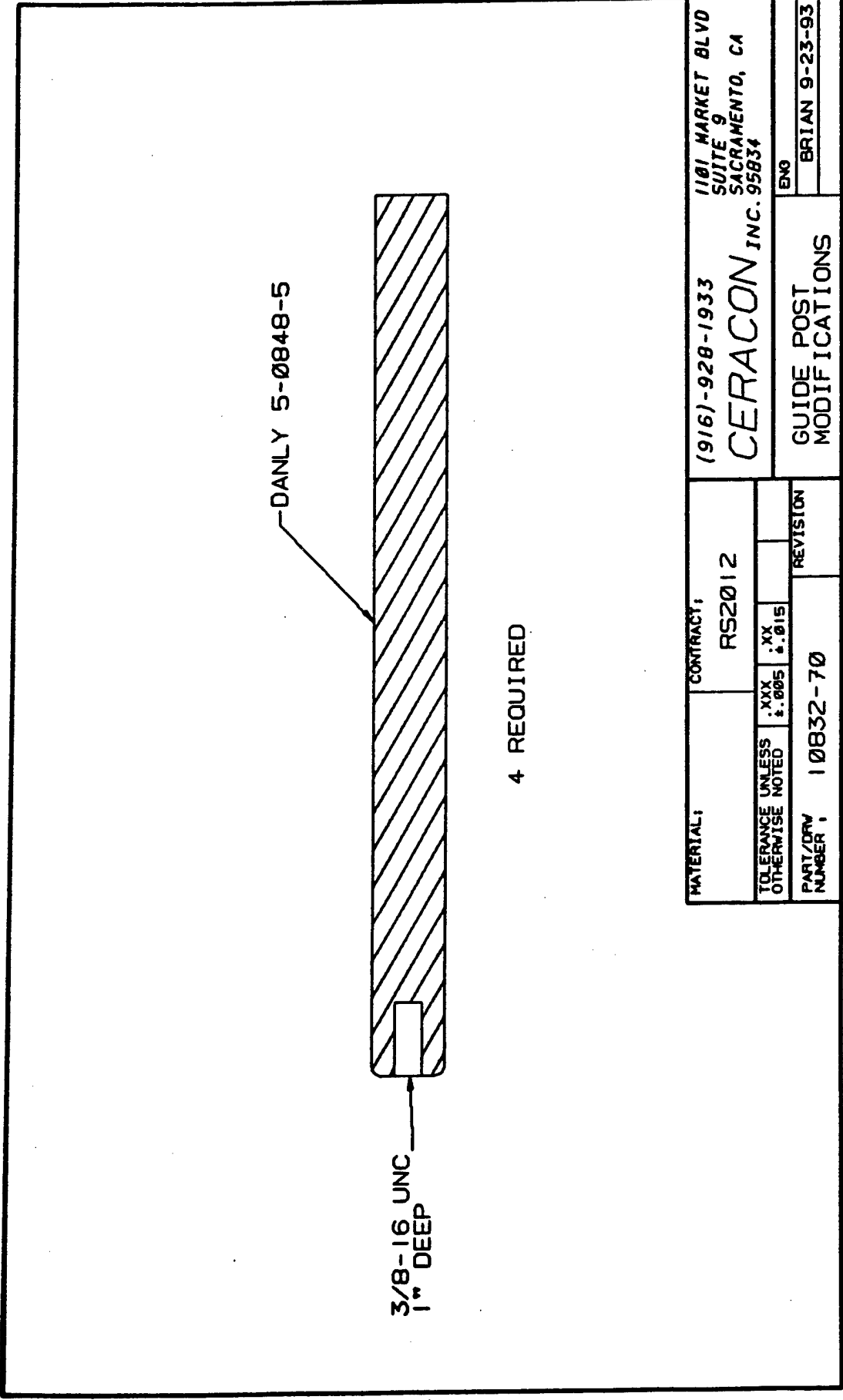

Figure B-6. TIC Cold Press Load Blocks.



DANLY 5-0848-5

3/8-16 UNC  
1" DEEP

4 REQUIRED

MATERIAL:		CONTRACT:		1181 MARKET BLVD SUITE 9 SACRAMENTO, CA	
		RS2012		CERA CON INC. 95834	
TOLERANCE UNLESS OTHERWISE NOTED	XXX ±.005	XX ±.015	EN9		
PART/DRV NUMBER	10832-70		GUIDE POST MODIFICATIONS		
			BRIAN 9-23-93		

Figure B-7. Guide Post Modifications.

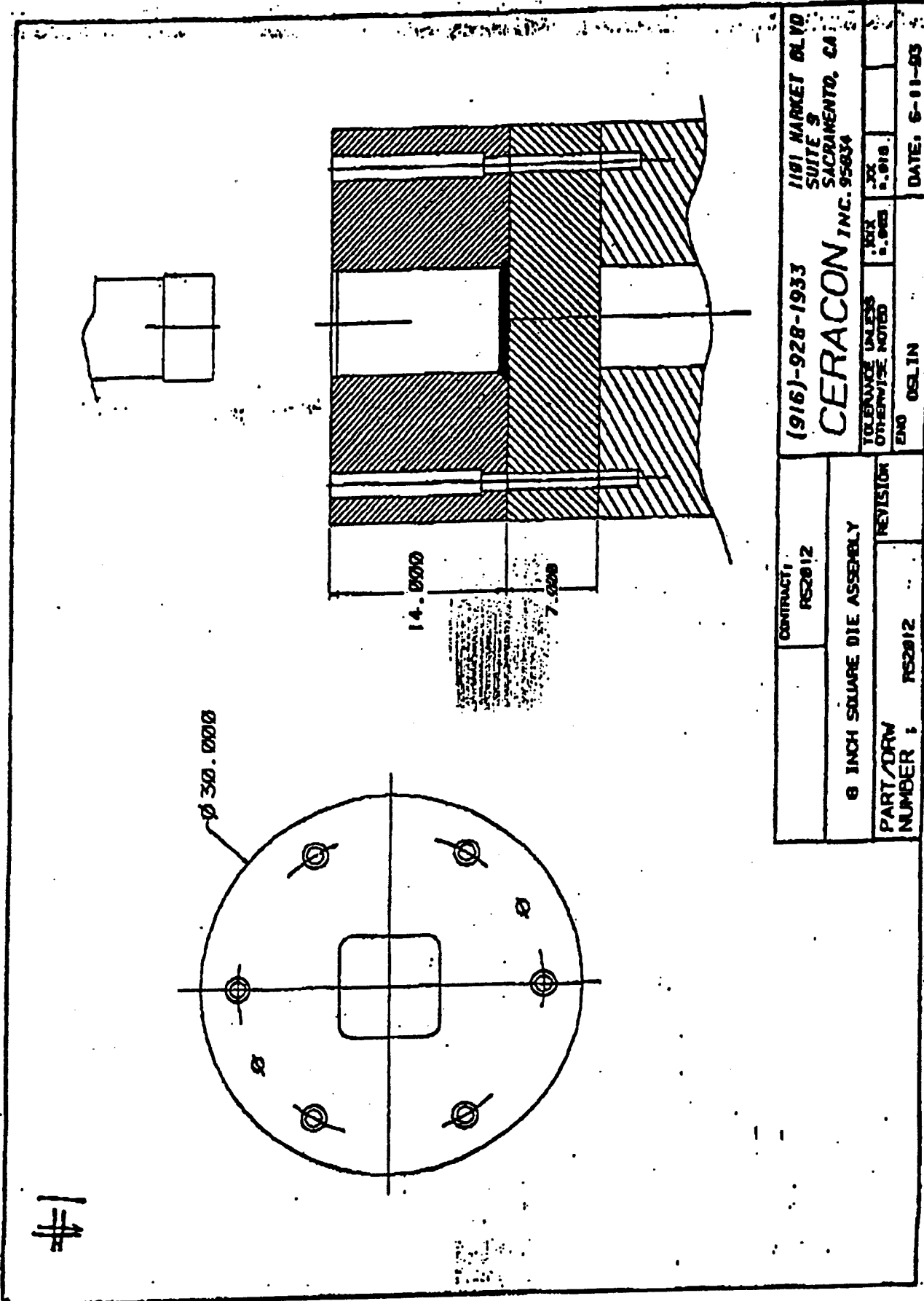
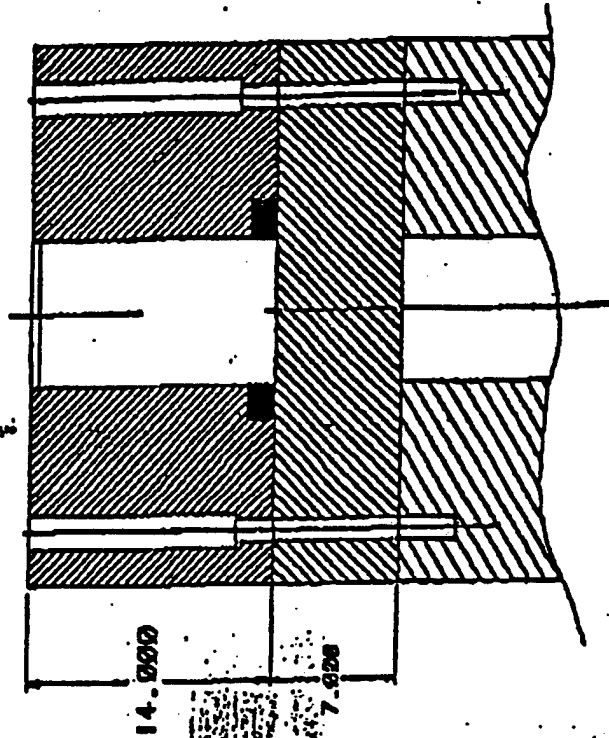
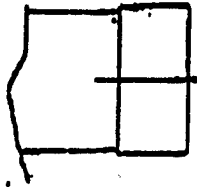
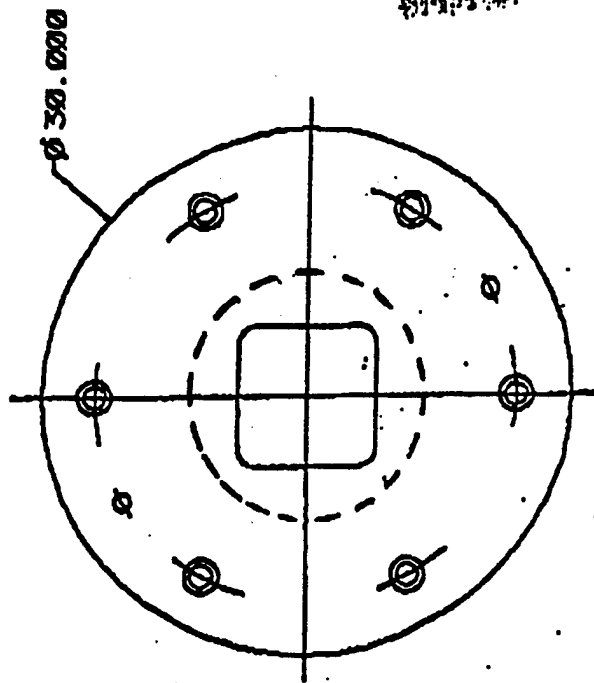

Figure B-8. 20-cm-Square Die Assembly No. 1.

#2



CONTRACT #		RS2812		1191 MARKET BLVD SUITE 9 SACRAMENTO, CA	
PART/DRW NUMBER 1		RS2812		CERACON INC. 95834	
REVISION		.XXX 2.065		.XX 2.018	
TOLERANCE UNLESS OTHERWISE NOTED		END		DATE: 6-11-83	

Figure B-9. 20-cm-Square Die Assembly No. 2.

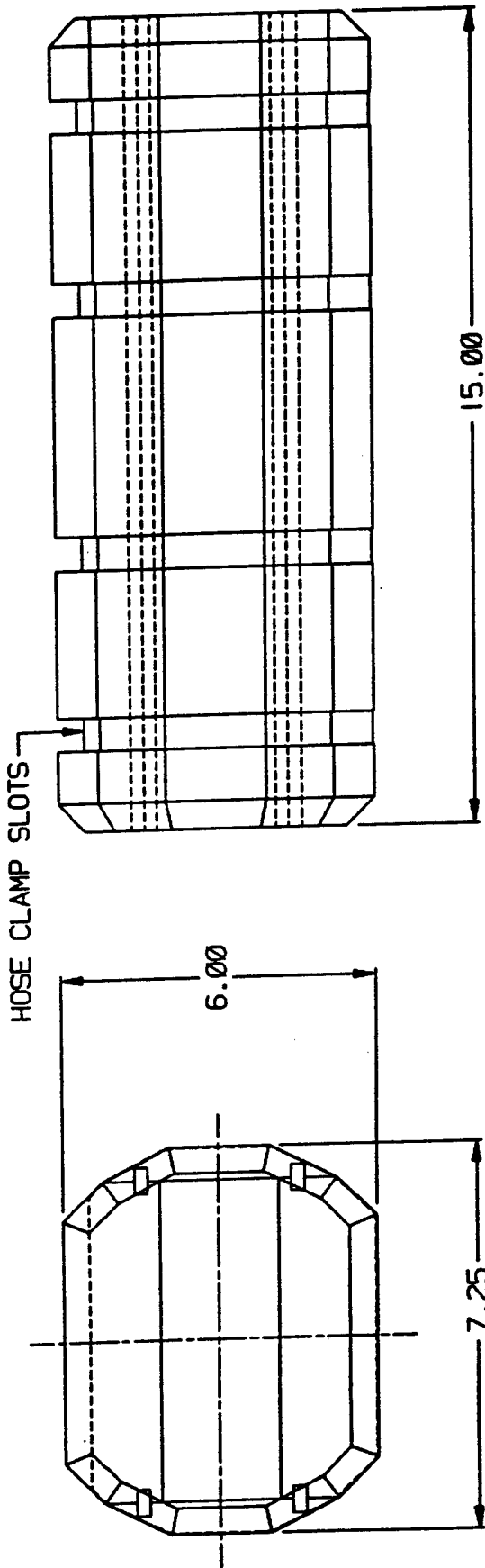

NOTES UNLESS OTHERWISE SPECIFIED:  
 A) FINISH ALL OUTSIDE SURFACES TO PREVENT PIERCING  
 CLAMP SURFACES  
 B) GRIND AND POLISH ALL INTERIOR SURFACES TO 16.

MATERIAL:	CONTRACT:	1181 MARKET BLVD SUITE 9 SACRAMENTO, CA	
OL TOOL STEEL HEAT TREAT TO RC 58-60	RS2012	(916)-928-1933	CERACON INC. 95834
TOLERANCE UNLESS OTHERWISE NOTED	.XXX ±.005	END: OSLIN	
PART/DRW NUMBER 1	RS2012-200	UCIP ASSEMBLED DIE	
		REVISION	
		PAGE 1 OF 5	

Figure B-10. Uniaxial Cold Isostatic Press (UCIP) Assembled Die.

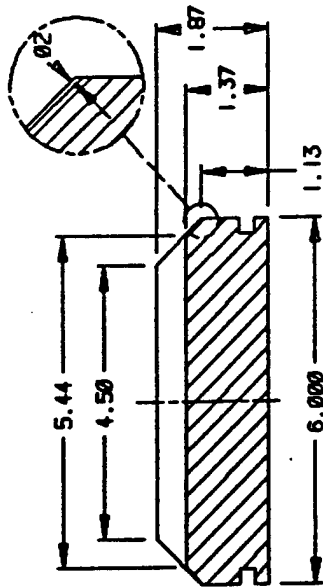

SECTION A-A

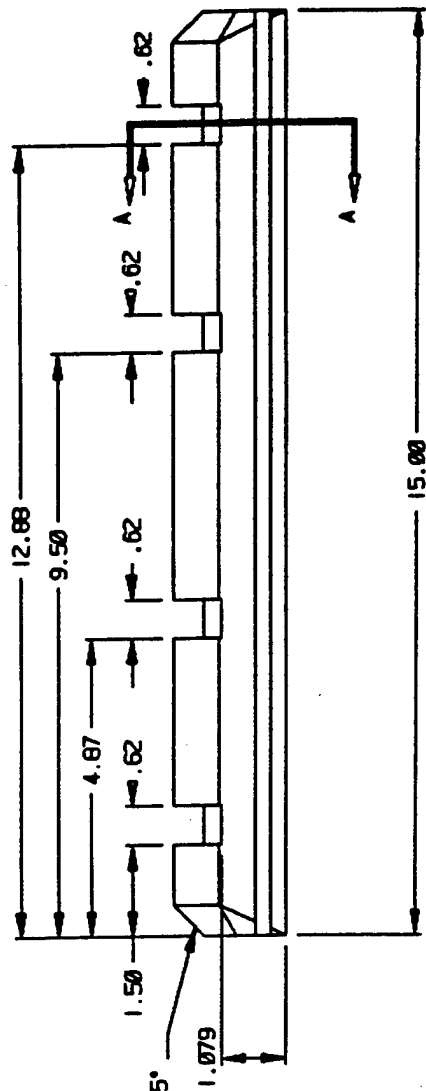
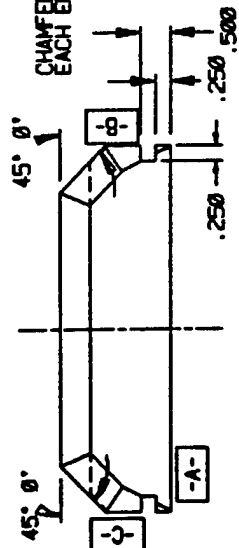

- NOTES UNLESS OTHERWISE SPECIFIED:  
 A) ROUND ALL OUTSIDE SURFACES TO PREVENT PIERCING CIP BAG.  
 B) GRIND AND POLISH SURFACES A,B,C TO 16  
 C) SURFACES B AND C MUST BE PERPENDICULAR TO A WITHIN .001

MATERIAL: O1 TOOL STEEL HEAT TREAT TO RC 58-60	CONTRACT: RS2012	(916)-928-1933 1101 MARKET BLVD SUITE 9 SACRAMENTO, CA CERACON INC. 95834	
TOLERANCE UNLESS OTHERWISE NOTED .XXX ±.002 ±.015	REVISION	ENG OSLIN	PAGE 2 OF 8
PART ORW NUMBER 1 RS2012-210	UCIP LEFT SIDE 1 REQUIRED		

Figure B-11. UCIP Left Side.

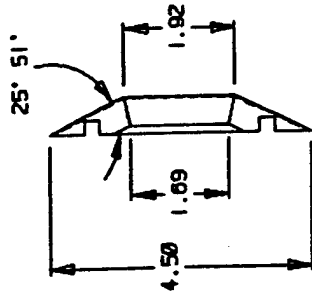
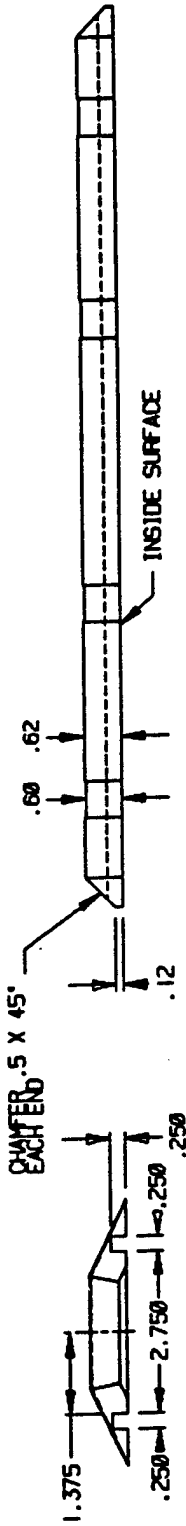

NOTES UNLESS OTHERWISE SPECIFIED:  
 A) ROUND ALL OUTSIDE SURFACES TO PREVENT PIERCING THE CIP BAG.  
 B) BRIND AND POLISH INSIDE SURFACE TO 10

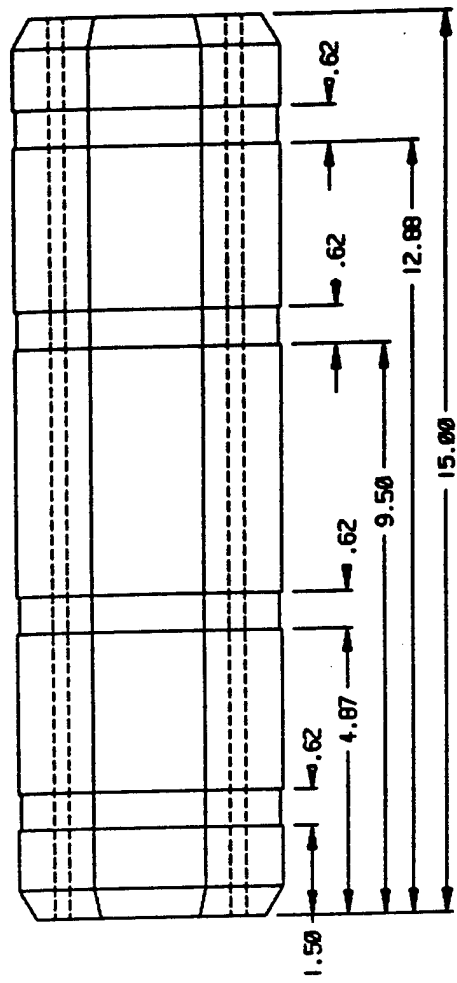

MATERIAL: QL TOOL STEEL HEAT TREAT TO RC 58-60		CONTRACT: RS2012		(916)-928-1933 1101 MARKET BLVD SUITE 9 SACRAMENTO, CA	
TOLERANCE UNLESS OTHERWISE NOTED ±.002 ±.015		REVISION		CERACON INC. 95834	
PART/DRV NUMBER 1 RS2012-220		UCIP SIDE CAP 2 REQUIRED		ENG OBLJN	
				PAGE 3 OF 6	

Figure B-12. UCIP Side Cap.

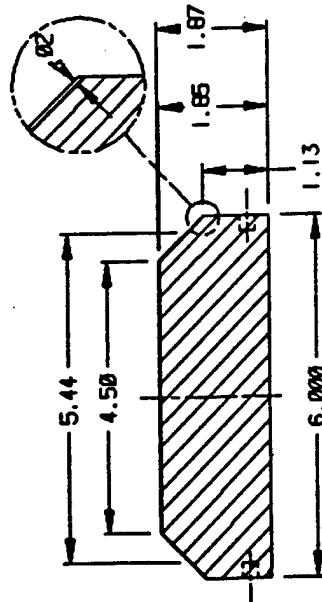

SECTION A-A

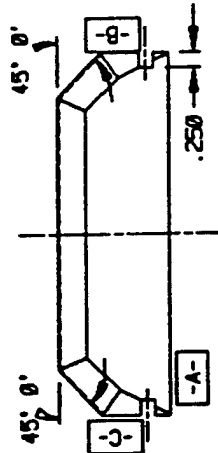

CHAMFER .5 X 45°  
EACH END

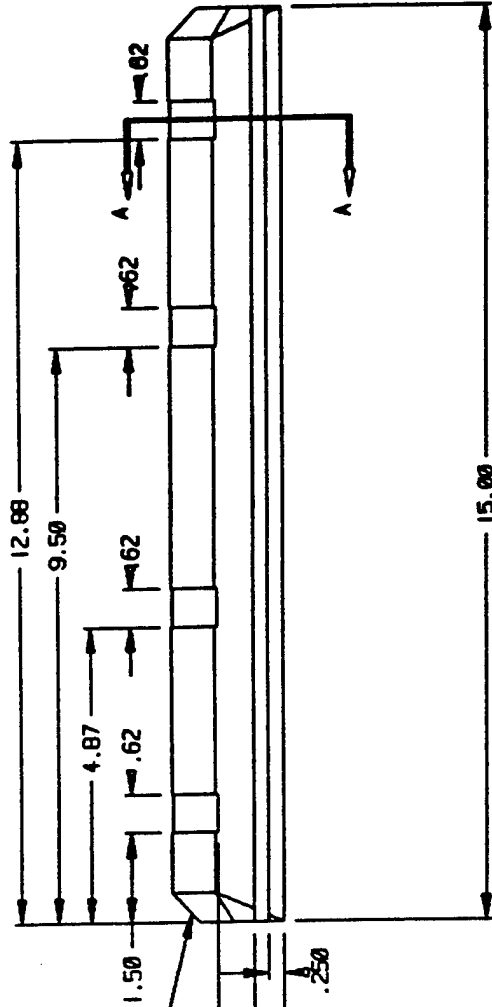

- NOTES UNLESS OTHERWISE SPECIFIED:  
 A) ROUND ALL OUTSIDE SURFACES TO PREVENT PIERCING CIP BAG.  
 B) GRIND AND POLISH SURFACES A,B,C TO 16  
 C) SURFACES B AND C MUST BE PERPENDICULAR TO A WITHIN  $\pm .001$

MATERIAL: PL 100 STEEL HEAT TREAT TO RC 58-60	CONTRACT: RS2012	(916)-928-1933 CERACON INC. 95834 1181 MARKET BLVD SUITE 9 SACRAMENTO, CA
TOLERANCE UNLESS OTHERWISE NOTED: .XX \$.002 \$.015	REVISION	END OBL IN
PART/DRV NUMBER: RS2012-230	UCIP RIGHT SIDE 1 REQUIRED	PAGE 4 OF 5

Figure B-13. UCIP Right Side.



INTENTIONALLY LEFT BLANK.

**Appendix C:**  
**Cost Model for the Manufacture of 1,000 Tiles**

INTENTIONALLY LEFT BLANK.

# Table of Contents

	<u>Page</u>
<b>C-1. Introduction</b> .....	73
<b>C-2. Assumptions</b> .....	73
<b>C-3. Production and Process Description</b> .....	74
C-3.1 CS/CF Process Description .....	74
C-3.2 Production Description .....	74
<b>C-4. Setup Costs and Capital Equipment</b> .....	75
C-4.1 Plant Design and Layout .....	75
C-4.2 Equipment and Materials Order .....	77
C-4.3 Setup .....	77
C-4.3.1 Powder Storage Area .....	77
C-4.3.1.1 Storage Compartment .....	77
C-4.3.1.2 Ball Mill .....	77
C-4.3.2 Cold Pressing of TiC Tiles .....	77
C-4.3.3 Preform Furnace .....	77
C-4.3.4 PTM Heating Furnace .....	78
C-4.3.5 Die Set Carousel System .....	78
C-4.3.6 Robotic Pick-and-Place Arms .....	78
C-4.3.7 PTM Discharge Station .....	78
<b>C-5. Manufacture of 1,000 Tiles</b> .....	79
C-5.1 Powder Order and Storage .....	79
C-5.2 Ball Milling and Storage of Milled Powders .....	79
C-5.3 Cold Pressing of Green Tiles .....	79
C-5.4 Grafoil Wrap Station .....	80
C-5.5 Preheating of Tiles .....	80
C-5.6 CS/CF of TiC Tiles .....	80
C-5.7 Slow Cooling the Tiles and Recycling of PTM .....	80
C-5.8 Part Identification .....	80
C-5.9 Machining .....	80
C-5.10 Delivery of Tiles .....	80
<b>C-6. Detailed Budgets</b> .....	81

INTENTIONALLY LEFT BLANK.

## **C-1. Introduction**

Ceracon, Incorporated is providing this cost model for the fabrication of 1,000 titanium carbide (TiC) tiles fabricated by the combustion synthesis/Ceracon forging (CS/CF) technology developed by Ceracon under Phase I and Phase II Small Business Innovative Research (SBIR) awards by the U.S. Army Research Laboratory (ARL). Work completed during Phases I and II successfully demonstrated fabrication of bulk shape, crack-free, high-density TiC tiles up to 15 cm × 15 cm × 2.5 cm at temperatures as low as 1,200° C. The development of this novel technology has resulted in the potential for economically manufacturing this high-temperature ceramic on a large-scale basis at a cost of 30–50% of conventionally prepared TiC. The technology developed at Ceracon under Army support has paved the way for dual-use applications. In defense industries, it could be used for lightweight armor, and, in commercial applications, it could be used for cutting tools, heating elements, and sputtering targets.

## **C-2. Assumptions**

This cost model to prepare 1,000 TiC tiles is based upon the research and technology experience gained as a result of the SBIR program and the following assumptions:\*

- initial studies to fabricate a pilot quantity of 10–25 TiC tiles has been completed;
- additional prototype quantities of 100 TiC tiles are fabricated and delivered to ARL;
- the capital equipment and setup is completed, as outlined in section C-4;
- the machining of the tiles will be done using an outside machine shop;

---

\* Although the cost model presented here is for 1,000 tiles, the pilot facility can be readily upgraded to a capacity of 50,000 tiles per year.

- the scrap rate for the production of 1,000 TiC tiles is assumed to be 6.5%; and
- Ceracon's fringe, overhead, and general and administrative rates remain substantially unchanged.

### **C-3. Production and Process Description**

**C-3.1 CS/CF Process Description.** The CS process involves initiation of a self-propagating reaction at low temperatures between elemental components to synthesize a high-temperature compound (e.g., titanium [Ti] and carbon [C] react to form TiC). However a stand alone CS process produces a material with 50% porosity. The Ceracon forging (CF) process involves application of pressure on a hot porous structure using a granular carbonaceous pressure-transmitting medium (PTM). The Ceracon innovation is to combine the combustion synthesis and CF process in one step (CS/CF), whereby in-situ synthesis and densification can be carried out. This technique has been successfully applied under ARL's support to fabricate large size (15 × 15 × 2.5 cm) TiC tiles.

**C-3.2 Production Description.** The Ti and C powders are received in 206-liter drums. C will be stored in an accessible portion of the receiving area, whereas Ti will be stored in a "safe area" with the ball mill and the milled (Ti+C) mixture. The safe area will be made of heavy gauge steel, filtered with dehumidifiers and static removal, and will be fire- and explosion-resistant.

The Ti and C barrels will be lifted by barrel lifters and poured into a 1,125-liter ball mill. The ball mill will have an explosion-proof motor and rubber lining and will use alumina (Al<sub>2</sub>O<sub>3</sub>) as the milling media. The mill will be rotated at speeds below the critical speeds, under conditions of dry milling, for a period of 3 hr. A grating will allow the milled powder to be collected in drums while holding the media in place. All powder flow passages will be filtered with inert atmosphere ducts and dust collectors.

The powder mixture will then be put into a hopper that flows through a control valve into the die of a cold press. A green preform tile will be pressed at a pressure of 55 MPa. The tile will then be covered on all sides with precut grafoil sheets.

The green tile will be placed onto a belt furnace where it is heated to a temperature between 600–1,000° C. Flame curtains and an argon (Ar) environment will provide an inert atmosphere. The part preheat furnace will be lined with refractory insulating bricks and will be electrically fired. A pick-and-place robot will pick up the tile from the furnace and hold it in the center of the die while a Procedyne furnace releases the PTM which has been heated to a temperature between 1,100–1,400° C. The dies are individually heated. There are five dies with one die functioning as the part and PTM discharge station. The dies move on a carousel shuttle system with a 2½-min halt at every station. After 7½ min, the die with the preheated part and PTM shuttles under the punch. Upon combustion, pressure is applied and the part is consolidated to a high density.

The die will then move to a discharge station where the part is placed in an insulating media for slow cooling and the PTM is collected and fed into a sieve system. Upon sieving out the fines, the PTM is returned to the Procedyne furnace.

After slow cooling, the part will then be machined by an outside vendor using diamond machining and finishing wheels to dimensions of 15 cm × 15 cm × 2.5 cm.

## **C-4. Setup Costs and Capital Equipment**

The setup stage of pilot-scale production will require 3,080 man-hr. The setup period will be completed in approximately 20–26 weeks from the initiation of the manufacturing program. The flow chart for pilot-scale production of 1,000 tiles is shown in Figure C-1.

**C-4.1 Plant Design and Layout.** A detailed plan of the pilot plant will be completed in approximately 2–3 weeks from the initiation of the program.



## SET UP

Plant Design and Layout



Equipment and Materials Order



Functional Set up



---

---

## MANUFACTURING

Powder Order and Storage



Ball Milling and Storage of Milled Powders



Cold Pressing of Tiles



Grafoil Wrapping



Preheat Tiles



CS/CF TiC Tiles



Slow Cooling of Tiles



Machining of Tiles



Delivery of 1,000 Tiles

Figure C-1. Flow Chart for Manufacturing of TiC Tiles.

**C-4.2 Equipment and Materials Order.** Quotations from several vendors will be requested and negotiations carried out for the best price and delivery schedules. This task is expected to be completed approximately 12–15 weeks from the initiation of the program.

### **C-4.3 Setup.**

#### ***C-4.3.1 Powder Storage Area.***

***C-4.3.1.1 Storage Compartment.*** Ti powder will be ordered in 206-liter drums containing approximately 204 kg of Ti in each container. This corresponds to 16 206-liter drums for fabrication of 1,000 tiles. Eight drums will be procured at the start of the program and eight more midway in the program. The powder storage area will be a thick-walled steel container to resist fire and explosion. The storage container will be static proof and fitted with dehumidifiers. This storage chamber will be roughly 6.1 m × 3.5 m × 2.4 m. The storage compartment is adequate to store enough powder for 1,000 tiles. If the program is upgraded to the full capacity of 50,000 tiles per year, storage capacity for 14 206-liter Ti drums will be needed and a larger chamber would be required.

***C-4.3.1.2. Ball Mill.*** A 1,125-liter ball mill will be purchased. Al<sub>2</sub>O<sub>3</sub> media will be used. The ball mill will be fitted with a rubber liner and will be rotated for 3 hr per batch. The ball mill will have an explosion-proof motor and dustless discharge housing. Barrel lifters for transfer of powder and drums for the storage of milled powders will be procured.

***C-4.3.2 Cold Pressing of TiC Tiles.*** A 600-ton press, capable of cold-pressing two tiles at a time, will be purchased. An automated powder loading system will be purchased, which will drop the same weight of TiC powder into the die each time. All paths where the powder may be exposed to the environment will be surrounded by a plastic glove bag arrangement with inert gas flowing.

***C-4.3.3 Preform Furnace.*** A 12.8-m belt furnace lined with ceramic refractory bricks will be purchased. Thermocouple readouts will be placed along the length of the furnace with provisions

to stop the belt and sounding of an alarm if the temperature exceeds 950° C. Inert gas will flow inside the furnace maintaining an inert environment. Flame curtains will be present at the entry point as well as the exit. The furnace will have a temperature capability of 1,100° C. Each tile will be in the furnace for a period of 1.5 hr, and, at any given time, there can be 36 tiles in the furnace with 20 cm between each tile. The belt speed will be 14.2 cm/min. Each tile will be separated from its neighboring tile by a ceramic wall so that, if a tile ignites in the furnace, its neighboring tiles will not be ignited from the heat of the combustion. The furnace will be set on railings.

**C-4.3.4 PTM Heating Furnace.** A fluidized bed furnace (Procedyne) capable of delivering 113 kg/hr of heated PTM will be procured. Approximately 11.3 kg/hr of PTM per part will be needed. For capacity production of 50,000 tiles/yr, an additional Procedyne would be required. The operating temperature will be approximately 1,200° C. Higher temperature materials for the muffle of the Procedyne will be used instead of the commonly used Inconel 600. A high-temperature discharge valve will release a predetermined amount of PTM into the die.

**C-4.3.5 Die-Set Carousel System.** Five die sets will be purchased. Currently, it takes approximately 10 min for the TiC part to ignite in the die. The part will be placed in the first die, which is right up against the preform furnace and the PTM Procedyne. The die will shuttle in a counterclockwise fashion on the carousel arriving in a four-step shuttle mode with the final step in the 7.5–10-min cycle being spent under the punch awaiting combustion. After combustion synthesis and dynamic forging, the die with the part will arrive at the discharge station. The dies will be heated to 300° C and be made of H-13 steel.

**C-4.3.6 Robotic Pick-and-Place Arms.** Robotic pick-and-place arms will pick up the part from the preform furnace and hold it in the die while the Procedyne discharges hot PTM into the die. Another pick-and-place arm will place the part after CS/CF from the discharge station and insert it into the slow-cooling media.

**C-4.3.7 PTM Discharge Station.** The PTM will be released into drums. After cooling, the drums will be poured into a sieve that will remove the fines and, through an auger system, return the

recycled PTM to the Procedyne furnace. It is estimated that approximately 10% of the PTM will be lost in each CS/CF cycle. The discharge station will also incorporate a robotic pick-and-place arm for removing the part.

## **C-5. Manufacture of 1,000 Tiles**

The equipment and layout necessary to manufacture 1,000 tiles has the capacity to produce up to 50,000 tiles/yr with a few additional pieces of equipment. The actual time required to manufacture 1,000 tiles is approximately 3 weeks using a standard 8-hr shift, 5 days/week. Including the time for powder procurement and initial set, the program is projected to be complete within 10–14 weeks from the initiation time.

**C-5.1 Powder Order and Storage.** Currently, a machined tile weighs 2.82 kg. With current processing, the starting weight of the tile is 3.69 kg. The losses occur in powder processing, combustion synthesis, forging, and machining. With the improvements in setup, the losses are expected to drop by a factor of 25–50%. Assuming a scrap rate of 6.5% for a 1,000 tiles, we will order 3,250 kg of Ti and 750 kg of C. The 3,250 kg of Ti will arrive in 16 206-liter drums. The -100+160 mesh Ti from Micron Metals will arrive in two consignments of eight drums each. All necessary safety precautions for storage and safe handling will be followed.

**C-5.2 Ball Milling and Storage of Milled Powders.** Powder transfer to the ball mill will be done under dust-free and inert conditions. All powder will be milled 2 days prior to CS/CF. The powder will be milled for 3 hr using  $\text{Al}_2\text{O}_3$  milling media. It is expected that a technician will be employed with about 75% of his/her time dedicated to ball milling, storage, inventory of powders, safety aspects, and transfer of as-received, as well as the milled powders.

**C-5.3 Cold Pressing of Green Tiles.** A pressure of 55 MPa will be applied to obtain a density of approximately 70% of theoretical. Once again, dust-free and inert conditions will be maintained during powder transfer and handling. A person dedicated to cold pressing will be employed, who will cold press the parts and transfer them to the grafoil wrap station.

**C-5.4 Grafoil Wrap Station.** The preformed tiles will be placed into precut sheets of grafoil prior to storage.

**C-5.5 Preheating of Tiles.** The tiles will be preheated to approximately 750° C and held at that temperature for about 45 min for a uniform heat soak. Thermocouples along the length of the belt furnace will monitor the temperature of the parts. An inert atmosphere will be maintained in the furnace. The number of tiles preheated/hour will be determined by the CS/CF consolidation rate and controlled by the spacing between the tiles or by the speed of the belt furnace. Ceramic barriers on the belt between the tiles will prevent a chain combustion reaction, if one of the tiles initiates combustion.

**C-5.6 CS/CF of TiC Tiles.** The hot tiles will be picked up by the pick-and-place arm and loaded in the die with the PTM simultaneously discharging into the die.

**C-5.7 Slow Cooling the Tiles and Recycling of PTM.** After forging, the part will be brought to a discharge station where the PTM will be recycled. We expect to recycle about 90% of the PTM with the remaining lost as fines or dust. The part will be cooled in insulating material over a period of 24 hr.

**C-5.8 Part Identification.** The part will be issued a unique number, which will identify it by the batch number of the powder it was milled from, the processing parameters, and the date and time of CS/CF forging.

**C-5.9 Machining.** Ceramic machining will be employed to machine the specimens to a flat finish on all sides. Machining of these specimens will be done by an outside vendor for annual production of 1,000 tiles. However, for full capacity production of 50,000 tiles/yr, equipment would be purchased and a dedicated machinist employed for machining.

**C-5.10 Delivery of Tiles.** After inspection to assure dimensions and density and to check for any surface irregularities, the specimens will be shipped. Shipping costs are not included in this cost proposal and would be at the responsibility of the purchaser.

## C-6. Detailed Budgets

Table C-1 displays the equipment purchase and setup, and Table C-2 shows the manufacturing details of 1,000 TiC tiles.

**Table C-1. Equipment Purchase and Setup Costs**

Direct Labor	Time (hr)	Rate (%)	Total (\$)
Administration	160	24.4385	3,910.15
Engineering Technician	640	8.0000	5,120.00
Management	120	84.1346	10,096.15
Materials Engineer	800	21.6346	17,307.69
Process Technician	1,040	11.5000	11,960.00
R & D Management	200	43.0288	8,605.77
Senior Process Technician	1,040	14.5000	15,080.00
Total Direct Labor	3,080	—	72,079.77
Fringe	—	30.00 (%)	21,623.93
Materials/Supplies	Quantity	Price (\$)	Total (\$)
Storage Compartment	1	11,000.00	11,000.00
Ball Mill Setup	1	50,000.00	50,000.00
Ball Mill Station for Powder Removal	1	6,000.00	6,000.00
Barrel Lifters	2	1,500.00	3,000.00
Cold Press	1	150,000.00	150,000.00
Cold Press Die and Punch	1	9,000.00	9,000.00
Powder Delivery and Fill Station	1	70,000.00	70,000.00
Trolleys and Miscellaneous	1	1,000.00	1,000.00
Procedyne	1	300,000.00	300,000.00
Dumping and Recycling Station	1	50,000.00	50,000.00

**Table C-1. Equipment Purchase and Setup Costs (continued)**

<b>Materials/Supplies</b>	<b>Quantity</b>	<b>Price (\$)</b>	<b>Total (\$)</b>
Preform Furnace	1	350,000.00	350,000.00
Forging Dies and Punches	5	20,000.00	100,000.00
Forging Carousel Setup	1	110,000.00	110,000.00
Pick and Place Systems	1	20,000.00	20,000.00
Rails, Guides, Stops, and Belts	1	15,000.00	15,000.00
Miscellaneous	1	200,000.00	200,000.00
<b>Total Materials/Supplies</b>	—	—	<b>1,445,000.00</b>
<b>Setup and Equipment</b>	—	—	<b>1,538,703.70</b>

**Table C-2. Manufacturing Costs of 1,000 TiC Tiles**

Direct Labor	Time (hr)	Rate (\$)	Total (\$)
Manufacturing Project Manager	400	21.6346	8,653.85
Senior Processing Tech	480	14.5000	6,960.00
Processing Technician	480	11.5000	5,520.00
Preforming Technician	320	15.0000	4,800.00
Engineering Technician	360	8.0000	2,880.00
Technician	560	7.0000	3,920.00
Total Direct Labor	2,600	—	32,733.85
Labor Overhead <sup>a</sup>	—	109.63 (%)	35,886.12
Subcontracts	Quantity	Rate (%)	Total (\$)
Machining Tiles <sup>b</sup>	1,050	160.00	168,000.00
Materials/Supplies	Quantity	Unit Price (\$)	Total (\$)
Ti Powder (kg)	3,250	41.80	135,850.00
C Powder (kg)	750	5.50	4,125.00
PTM (kg)	3,625	2.43	8,808.75
Grafoil Wrap (roll)	1	3,500.00	3,500.00
Furnace Elements (ea.)	20	400.00	8,000.00
Gases (bottles)	80	40.00	3,200.00
Thermocouples (ea.)	15	105.00	1,575.00
Storage Containers (ea.)	3	1,000.00	3,000.00
Ball Mill, Cold Press, Forging Supplies (ea.)	3	2,000.00	6,000.00
Depreciation for Capital Investment <sup>c</sup>	—	153,870.37	153,870.37
Total Materials/Supplies	—	—	327,929.12

<sup>a</sup> Ceracon's existing overhead rate.

<sup>b</sup> Outside vendor.

<sup>c</sup> 10-yr declining: if full capacity of 50,000 parts were produced, depreciation would be spread over 50,000 parts, significantly lowering the per tile cost.



**Table C-2. Manufacture of 1,000 TiC Tiles (continued)**

Materials/Supplies	Quantity	Price (\$)	Total (\$)
General and Administrative (G&A) <sup>d</sup>	—	47.07%	265,733.25
Contingency and Profit <sup>e</sup>	—	20.00%	166,056.46
Grand Total	—	—	996,338.80
Per Tile Cost	—	—	996.34

<sup>d</sup> Ceracon's existing G&A rate.

<sup>e</sup> Allowance for unexpected costs and profit.

<u>NO. OF COPIES</u>	<u>ORGANIZATION</u>	<u>NO. OF COPIES</u>	<u>ORGANIZATION</u>
2	DEFENSE TECHNICAL INFORMATION CENTER DTIC DDA 8725 JOHN J KINGMAN RD STE 0944 FT BELVOIR VA 22060-6218	1	DIRECTOR US ARMY RESEARCH LAB AMSRL D R W WHALIN 2800 POWDER MILL RD ADELPHI MD 20783-1145
1	HQDA DAMO FDQ D SCHMIDT 400 ARMY PENTAGON WASHINGTON DC 20310-0460	1	DIRECTOR US ARMY RESEARCH LAB AMSRL DD J J ROCCHIO 2800 POWDER MILL RD ADELPHI MD 20783-1145
1	OSD OUSD(A&T)/ODDDR&E(R) R J TREW THE PENTAGON WASHINGTON DC 20301-7100	1	DIRECTOR US ARMY RESEARCH LAB AMSRL CS AS (RECORDS MGMT) 2800 POWDER MILL RD ADELPHI MD 20783-1145
1	DPTY CG FOR RDE HQ US ARMY MATERIEL CMD AMCRD MG CALDWELL 5001 EISENHOWER AVE ALEXANDRIA VA 22333-0001	3	DIRECTOR US ARMY RESEARCH LAB AMSRL CI LL 2800 POWDER MILL RD ADELPHI MD 20783-1145
1	INST FOR ADVNCD TCHNLGY THE UNIV OF TEXAS AT AUSTIN PO BOX 202797 AUSTIN TX 78720-2797		<u>ABERDEEN PROVING GROUND</u>
1	DARPA B KASPAR 3701 N FAIRFAX DR ARLINGTON VA 22203-1714	4	DIR USARL AMSRL CI LP (305)
1	NAVAL SURFACE WARFARE CTR CODE B07 J PENNELLA 17320 DAHLGREN RD BLDG 1470 RM 1101 DAHLGREN VA 22448-5100		
1	US MILITARY ACADEMY MATH SCI CTR OF EXCELLENCE DEPT OF MATHEMATICAL SCI MAJ M D PHILLIPS THAYER HALL WEST POINT NY 10996-1786		

NO. OF  
COPIES ORGANIZATION

2 US ARMY ARDEC  
D KAPOOR  
S CYTRON  
DOVER NJ 07801

3 ARMY RSRCH OFFICE  
A CROWSON  
E CHEN  
R REEBER  
PO BOX 12211  
RSRCH TRIANGLE PARK NC  
27709-2211

1 US ARMY AVIATION SYS CMD  
AVIATION APPLIED TECH DIR  
S KINNEY  
FT EUSTIS VA 23604-5577

1 DAHLGREEN LABORATORY  
NAVAL SURFC WEAPONS CTR  
P ADAMS  
CODE G 32 AMMUN BR  
DAHLGREEN VA 22448

1 NAVAL RSRCH LABORATORY  
V PROVENZANO  
CODE 2627  
WASHINGTON DC 20375

1 THE TITAN CORP  
CRT DIV ORD TECHLGY  
R BROWN  
5117 JOHNSON DRV  
PLEASANTON CA 94588

2 WRIGHT LABORATORY  
WL MNMW M DILMORE  
MUNITIONS DIV  
J FOSTER  
EGLIN AFB FL 32542-6810

1 FAILURE ANALYSIS ASSOC  
J NEIL  
149 COMMONWEALTH DR  
PO BOX 3015  
MENLO PARK CA 94025

NO. OF  
COPIES ORGANIZATION

1 LLNL  
PHYSICS DEPT  
W J NELLIS  
LIVERMORE CA 94550

1 OAK RIDGE NATL LAB  
A PASTO  
MS 6087 BLDG 4508  
BOX 2008  
OAK RIDGE TN 37831

1 SURMET CORP  
S SASTRI  
33 B STREET  
BURLINGTON MA 01803

2 SNL  
FUSION TECHLGY DEPT 6531  
M ULHRIKKSON  
R WATSON  
ALBUQUERQUE NM 87185

1 LLNL  
B HOGAN  
ATAC MS F681  
PO BOX 1663  
LOS ALAMOS NM 87545

1 BATTELLE PACIFIC NW  
LABORATORIES  
W GURWELL  
PO BOX 999  
RICHLAND WA 99352

1 PENNSYLVANIA STAT UNIV  
DEPT ENGNR SCIENCES AND  
MECHANICS  
R GERMAN  
227 HAMMOND BLDG  
UNIVERSITY PARK PA  
16802-1401

1 UNIV OF CALIFORNIA  
SAN DIEGO  
DEPT APPLIED MECHANICS  
AND ENGNR SCIENCES  
M MEYERS  
MAIL CODE 0411  
9500 GILMAN DRIVE  
LA JOLLA CA 92093-0411

NO. OF  
COPIES ORGANIZATION

2 GEORGIA INST OF TECH  
SCHL OF MTRL ENG  
K LOGAN  
N THADANI  
ATLANTA GA 30332-0245

1 BATTELLE  
METALS AND CERAMICS DEPT  
R TENAGLIA  
505 KING AVENUE  
COLUBUS OH 43201-2693

1 B BUSOVNE  
23414 SHADYCRAFT  
TORRANCE CA 90505

3 NEW MEXICO INST  
OF MINING & TECH  
CTR FOR EXPLSV TECH & RSRCH  
A MILLER  
P PERSSON  
MTRLS & MET ENG  
O INAL  
SOCORRO NM 87801

1 UNIV OF CALIFORNIA  
COLLEGE OF ENGNRNG  
Z MUNIR  
DAVIS CA 95616

NO. OF  
COPIES ORGANIZATION

ABERDEEN PROVING GROUND

20 US ARMY RESEARCH LAB  
AMSRL WM TE  
L KECSKES (5 CPS)  
A NILER  
AMSRL WM TA  
W GOOCH  
W GILLICH  
M BURKINS  
G HAUSER  
T HAVEL  
E HORWATH  
AMSRL WM TD  
K FRANK  
AMSRL WM TC  
E KENNEDY  
L MAGNESS  
AMSRL WM M  
D VIECHNICKI  
AMSRL WM MC  
J LASALVIA  
T HYNES  
J MCCAULEY  
J WELLS

INTENTIONALLY LEFT BLANK.

REPORT DOCUMENTATION PAGE			Form Approved OMB No. 0704-0188	
Public reporting burden for this collection of information is estimated to average 1 hour per response, including the time for reviewing instructions, searching existing data sources, gathering and maintaining the data needed, and completing and reviewing the collection of information. Send comments regarding this burden estimate or any other aspect of this collection of information, including suggestions for reducing this burden, to Washington Headquarters Services, Directorate for Information Operations and Reports, 1215 Jefferson Davis Highway, Suite 1204, Arlington, VA 22202-4302, and to the Office of Management and Budget, Paperwork Reduction Project (0704-0188), Washington, DC 20503.				
1. AGENCY USE ONLY (Leave blank)	2. REPORT DATE April 1999	3. REPORT TYPE AND DATES COVERED Final, 9 Sep 92 - 9 Sep 94		
4. TITLE AND SUBTITLE A Novel Manufacturing Processing Route for Forming High-Density Ceramic Armor Materials: Phase II - SBIR			5. FUNDING NUMBERS Contract #DAA 92-C-0068 BRL000-1992-0493	
6. AUTHOR(S) Ramas V. Raman				
7. PERFORMING ORGANIZATION NAME(S) AND ADDRESS(ES) Ceracon, Inc. 1101 North Market Blvd., Suite 9 Sacramento, CA 95834			8. PERFORMING ORGANIZATION REPORT NUMBER TR-RS2012-F-1	
9. SPONSORING/MONITORING AGENCY NAMES(S) AND ADDRESS(ES) U.S. Army Research Laboratory ATTN: AMSRL-WM-TE Aberdeen Proving Ground, MD 21005-5066			10. SPONSORING/MONITORING AGENCY REPORT NUMBER ARL-CR-438	
11. SUPPLEMENTARY NOTES Andrus Niiler, COTR Laszlo J. Kecskes, ACOTR				
12a. DISTRIBUTION/AVAILABILITY STATEMENT Approved for public release; distribution is unlimited.			12b. DISTRIBUTION CODE	
13. ABSTRACT (Maximum 200 words)  The feasibility of a combustion synthesis/Ceracon forging (CS/CF) fabrication process for low-cost high-quality ceramic armor is demonstrated. CS of titanium (Ti) and carbon (C) forming titanium carbide (TiC) was followed by a quasi-isostatic pressurization and densification to produce tiles with 95%+ densities with sizes of up to 15 cm x 15 cm x 2.5 cm. Several tiles were fabricated and delivered to the U.S. Army Research Laboratory (ARL) for evaluation and testing. A cost model, which showed that approximately 60% in cost savings can be realized with the CS/CF method, was developed.  Temperature measurements and one-dimensional (1-D) computations were used to develop thermal management practices to make crack-free tiles. X-ray diffraction (XRD) verified full conversion of reactants to products. A considerable variation in TiC grain size and microhardness was found between the surface (~10 µm, high hardness) and the interior (up to 100 µm, low hardness) that depended on conditions during processing. Fractography showed transgranular fracture in the interior and intergranular fracture at the surface. Quasi-static compressive strength was found to be 1.79 GPa, while the flexural strength, determined from four-point bending tests, was 0.17 GPa.				
14. SUBJECT TERMS armor, TiC, combustion synthesis, Ceracon forging, densification			15. NUMBER OF PAGES 94	
			16. PRICE CODE	
17. SECURITY CLASSIFICATION OF REPORT UNCLASSIFIED	18. SECURITY CLASSIFICATION OF THIS PAGE UNCLASSIFIED	19. SECURITY CLASSIFICATION OF ABSTRACT UNCLASSIFIED	20. LIMITATION OF ABSTRACT UL	

**INTENTIONALLY LEFT BLANK.**

**USER EVALUATION SHEET/CHANGE OF ADDRESS**

This Laboratory undertakes a continuing effort to improve the quality of the reports it publishes. Your comments/answers to the items/questions below will aid us in our efforts.

- 1. ARL Report Number/Author ARL-CR-438 (Raman [POC: Kecskes]) Date of Report April 1999
- 2. Date Report Received \_\_\_\_\_
- 3. Does this report satisfy a need? (Comment on purpose, related project, or other area of interest for which the report will be used.) \_\_\_\_\_  
\_\_\_\_\_  
\_\_\_\_\_
- 4. Specifically, how is the report being used? (Information source, design data, procedure, source of ideas, etc.) \_\_\_\_\_  
\_\_\_\_\_  
\_\_\_\_\_
- 5. Has the information in this report led to any quantitative savings as far as man-hours or dollars saved, operating costs avoided, or efficiencies achieved, etc? If so, please elaborate. \_\_\_\_\_  
\_\_\_\_\_  
\_\_\_\_\_
- 6. General Comments. What do you think should be changed to improve future reports? (Indicate changes to organization, technical content, format, etc.) \_\_\_\_\_  
\_\_\_\_\_  
\_\_\_\_\_  
\_\_\_\_\_

**CURRENT  
ADDRESS**

\_\_\_\_\_  
**Organization**

\_\_\_\_\_  
**Name** **E-mail Name**

\_\_\_\_\_  
**Street or P.O. Box No.**

\_\_\_\_\_  
**City, State, Zip Code**

7. If indicating a Change of Address or Address Correction, please provide the Current or Correct address above and the Old or Incorrect address below.

**OLD  
ADDRESS**

\_\_\_\_\_  
**Organization**

\_\_\_\_\_  
**Name**

\_\_\_\_\_  
**Street or P.O. Box No.**

\_\_\_\_\_  
**City, State, Zip Code**

(Remove this sheet, fold as indicated, tape closed, and mail.)  
**(DO NOT STAPLE)**