



JPRS Report

Science & Technology

Europe

ONERA: 1987 Report of French Aerospace Research Agency

19990211 089

REPRODUCED BY
U.S. DEPARTMENT OF COMMERCE
NATIONAL TECHNICAL INFORMATION SERVICE
SPRINGFIELD, VA. 22161

DISTRIBUTION STATEMENT A
Approved for public release:
Distribution Unlimited

DTIC QUALITY INSPECTED 3

Science & Technology Europe

ONERA: 1987 Report of French Aerospace Research Agency

JPRS-EST-89-013

CONTENTS

18 APRIL 1989

WEST EUROPE

AEROSPACE, CIVIL AVIATION

ONERA: 1987 Report of French Aerospace Research Agency [Chatillon OFFICE NATIONAL D'ETUDES ET DE RECHERCHES AEROSPATIALES, Apr 88]	. 1
Introduction	1
Aerodynamics Department	3
Energetics Department	5
Systems Department	8
Large Testing Facilities	10
Materials Department	11
Computer Science Department	14
Physics Department	20
Structures Department	23
Toulouse Research Center	24
Lille Institute of Fluid Mechanics	31

AEROSPACE, CIVIL AVIATION

ONERA: 1987 Report of French Aerospace Research Agency

Introduction

36980121 Chatillon OFFICE NATIONAL D'ETUDES ET DE RECHERCHES AEROSPATIALES in English
Apr 88 pp 6-10

Historical Survey

[Excerpts] ONERA [National Institute for Aerospace Research and Studies] was founded in 1946 as a scientific and technical public establishment, managed according to industrial and commercial practice, enjoying financial autonomy and placed under the authority of the Minister of Defense or, more precisely, the General Delegate for Armament (DGA), equivalent to the British Procurement Executive or the U.S. Director of Defense Research and Engineering. Its mission is to "develop, orient and, in connection with services or organizations in charge of scientific and technical research, coordinate research in the field of aeronautics".

The statutory texts concerning ONERA were modified in April 1963 in the light of two new considerations: the appearance of space research and the reorganization of the Defense Ministry itself, in particular the creation of the Directorate for Research and Testing Facilities (DRME) now the Directorate of Armament Research Studies and Techniques (DRET) whose coordinating and orienting action was placed in broader framework of the defense field as a whole.

Concerning the first point, it was stated that ONERA (the "A" in whose name was changed from "aeronautical" to "aerospace") "in connection with CNES (the then newly founded Space Agency), contributes, by its own action and through research agreements, to the development of research and experimental projects in the space field, mainly for defense applications".

In the framework of decentralization of the Ecole Nationale Supérieure de l'Aéronautique et de l'Espace (ENSAE), ONERA took charge of the Toulouse Research Center (CERT) with a staff of some 240, attached to this school, in 1968.

The Lille Institute of Fluid Mechanics (IMFL), a research institute with a staff of around 100, was attached to ONERA by a 1983 decree.

In 1984, after confirming the traditional mission of ONERA (aerospace research and technical support for the national industry), a decree of January 11 restated this mission by asserting the role of ONERA in definition and development of computation facilities, promoting of research (possibly outside the aerospace field) and training of researchers.

Facilities

ONERA employs some 2100 people (including the CERT and IMFL), of whom more than two-thirds are engineers and technicians. Its plants are located:

- in the Ile-de-France region: at Chatillon (headquarters and main laboratories), Chalais-Meudon (research wind tunnels), Palaiseau (research facilities for energetics);
- Modane-Avrieux (large industrial wind tunnels);
- in the Toulouse region: CERT and Le Fauga-Mauzac Test Center. This center which is to receive the new large testing facilities will play a growing part in research in the aerodynamic and propulsion fields;
- Lille (in particular flight mechanics and structural mechanics facilities).

Organization

By application of the January 11, 1984 decree, general management of ONERA is ensured by the Chairman of the Board. The Chairman is assisted by a High Scientific Committee and a Scientific and Technical Committee.

The organization and functioning of ONERA were specified by a second decree of January 11, 1984.

The Chairman of ONERA prepares the research and development programs and technical investment programs. This preparation is within the framework of the general guidelines given by the Minister of Defense, in consideration of the scientific policy proposed by the High Scientific Committee. The Chairman carries out this preparation with the DRET Director, associating the Government agencies and organizations concerned, in particular those of the Direction Générale de l'Aviation Civile (General Directorate for Civil Aviation, the French equivalent of U.S. FAA or British CAA). After consulting with the Scientific and Technical Committee, these projects are submitted to the approval of the Board before being adopted by the Ministry of Defense (Delegation Générale pour l'Armement—Ministerial Delegation for Armament).

The Chairman directs the scientific and technical activity of ONERA, supervises execution of the programs and the study or research orders placed by outside public or private organizations, and prepares the budgets.

He is assisted by a Secretary General who replaces him in case of absence or inability, by a General Scientific Director and a General Technical Director.

The General Scientific Director is responsible for preparing definition of the long range scientific policy of ONERA and ensuring insertion of the programs in the framework of this policy. He is the Chairman of the Scientific and Technical Committee.

The General Technical Director coordinates the activities of the operational departments (Systems, Aerodynamics, Energetics, Materials, General Physics, Structures, Large Testing Facilities, Computer Science). He is assisted by a Director for Military Applications, a Director for Programs and Infrastructure, a Director for Aeronautical Applications and high-level engineers to coordinate the activities conducted in certain sectors.

The General Inspector, in addition to his functions as inspector and adviser, coordinates all the scientific and technical relations on an international scale.

The heads of the Modane-Avrieux and Le Fauga-Mauzac Centers are under the authority of the Director of the Large Testing Facilities.

Mission

ONERA contributes to progress in aerospace techniques with its fundamental research, complementing university laboratories; with its applied research, preparing long- and medium-term projects; and with its direct technical assistance to industry, either by making the testing potential of its centers available or by studying problems raised by actual projects under development or difficulties encountered on operational equipment. Thus, ONERA serves as a link between scientific work and aerospace manufacturers' programs in the design and production stage, whether for civil or military use.

ONERA's activity covers many fields, as the solution of the difficult and varied problems raised by aircraft and spacecraft design involves multiple disciplines and techniques, some of which lie outside the traditional aerospace area (data processing, solid state physics, coherent optics); conversely, the results often find applications in areas more or less far removed from their initial purpose.

ONERA works in close cooperation with similar establishments sponsored by other Government branches or covering neighboring or complementary disciplines. Its scientists keep up constant scientific contact with their colleagues abroad, particularly within the framework of AGARD, the NATO Advisory Group for Aerospace Research and Development. ONERA takes an active part in cooperative studies with various foreign and multinational (especially European) establishments and organizations. It stays in very close touch with French aerospace manufacturers, both at the level of its Board and Scientific and Technical Committee and that of its different offices and engineering teams.

ONERA protects some of its findings through patents, with a view to helping French industry in high technology fields. Patents are filled jointly with industrial companies whenever these take part in development. Research results are made available to industry as a whole, by an engineer reporting to the Director of Economic and Financial Affairs.

Licenses are sometimes granted to foreign firms, but priority is given to the rights of French industries already granted licenses of the same nature.

Management and Administration

1. Budget

a) Current Expenses	Million Fr	%
Net Operating Funds		
Ministry of Defense funding	371.0	35.4
Ministry of Research contribution	9.0	1.0
Contracts	651.0	62.2
Other proceeds	15.0	1.4
Total	1046.0	

Use of the Above Funds

(breakdown of activities by application)

Aircraft, helicopters and aeronautical equip.	42.0
Turbomachines	9.3
Strategic and tactical missiles, military systems	32.5
Space	8.5
Non-aerospace studies	0.9
Multi-purpose studies	6.8

b) Investments

Resources

Ministry of Defense subsidies	91.0	63.6
Ministry of Transportation (DGAC) contribution	8.0	5.6
Contribution of Regions	1.0	0.7
Self-financing (depreciation and reserve for investment)	34.7	24.3
Contracts (including construction of equipment left at the disposal of ONERA)	8.3	5.8
Total	143.0	

Use of the Above Resources

(breakdown of program funding per center of activity)

Test centers:

Chalais-Meudon	11.9
Palaiseau	12.1
Modane-Avrieux	24.4
Le Fauga-Mauzac	9.0

Laboratories:

Chatillon	23.0
Toulouse Research Center	7.7
Lille Fluid Mechanics Institute	3.8

General facilities	8.1
--------------------	-----

The average staff in 1987 is broken down as follows:

2. Manpower

By sector of activity:

Systems	179
Aerodynamics	184
Energetics	184
Materials	107
General physics	160
Structures	116
Large Test Facilities	323
Computer Facilities (excluding CERT and IMFL)	54
Common technical staff (SAT, TNE)	220
Executive and common administrative staff	245
CERT	243
IMFL	110
—Grand total	2,125

By plant:

Chatillon	1071
Chalais-Meudon	252
Palaiseau	162
Modane	218
Le Fauga	69
CERT	243
IMFL	110
—Total	2,125

By category:

Engineers and executive	972
Draftsmen, Staff Supervisors, Technicians	722
Workers	124
Clerical staff	307
—Total	2,125

[Passage omitted]

Aerodynamics Department

36980121 Chatillon OFFICE NATIONAL D'ETUDES ET DE RECHERCHES AEROSPATIALES in English Apr 88 pp 12-14

The activities of the Aerodynamics Department fall under two headings: fundamental and applied aerodynamics.

The aim of fundamental aerodynamics is to develop ways of predicting flows. This essentially means developing computation codes for solving the equations of fluid mechanics at various levels of approximation: the potential equation and the Euler equations in inviscid fluid, to determine the flow around relatively complex configurations, and the Navier-Stokes equations for viscous flows around simpler configurations. When strong interactions are involved (separations, shock-boundary layer interaction, etc.), the effects of the viscosity are determined either by the Navier-Stokes equations or by

an inviscid-viscous fluid coupling. Accounting for viscosity in a turbulent flow means modeling the turbulence in a way that is adapted to the particular flow being studied. The search for such models is based either on numerical simulation or on experimentation.

Detailed experimental analyses are made of complex three-dimensional flows over simple geometric configurations, with the dual purpose of improving our understanding of the fundamental physical phenomena at play while at the same time generating experimental databases to validate the mathematical models and numerical methods.

Applied aerodynamics adapts these prediction methods to specific problems encountered by the aircraft industry, and validates them by comparison with experimental data, analyzing the flows around realistic configurations to bring out the problems raised by the theoretical prediction of these flows, or to develop semi-empirical methods of prediction. In certain cases, applied aerodynamics looks for changes of shape that can improve performance. These studies touch upon the aerodynamics of airplanes, helicopters and missiles. Part of the research also concerns the use of new test systems.

Leading Staff

Scientific Director	Claude Capelier
Assistant Scientific Director for Applications	Bernard Monnerie
Assistant Scientific Director for Research	Henri Viviand
Scientific Assistant	Otto Leuchter
Technical Assistant	Pierre Weber
Theoretical Aerodynamics 1	Philippe Morice
Theoretical Aerodynamics 2	Yves Morchoisne
Theoretical Aerodynamics 3	Jean-Claude Le Balleur
Applied Aerodynamics 1	Gerard Laruelle
Applied Aerodynamics 2	Robert Larguier
Applied Aerodynamics 3	Jean-Jacques Thibert
Fundamental Aerodynamics	Jean Delery
Experimental Aerodynamics	Jean-Pierre Chevallier
Senior scientists	Tran Khoa Dang
	Colmar Rehbach
	Jean-Louis Solignac
	Jean-Pierre Veuillot
	Henri Werle

Contents

I. Fundamental Aerodynamics

- I.1. Recent Developments in Panel Methods
- I.2. Computation of Steady Three-Dimensional Flows of Compressible and Incompressible Inviscid Fluid by Pseudo-Unsteady Solution of the Euler Equations
- I.3. Centered Implicit Method Without Artificial Viscosity for the Euler Equations
- I.4. Numerical Simulation of Complex Three-Dimensional Flows of Inviscid Gas with Upwind Schemes

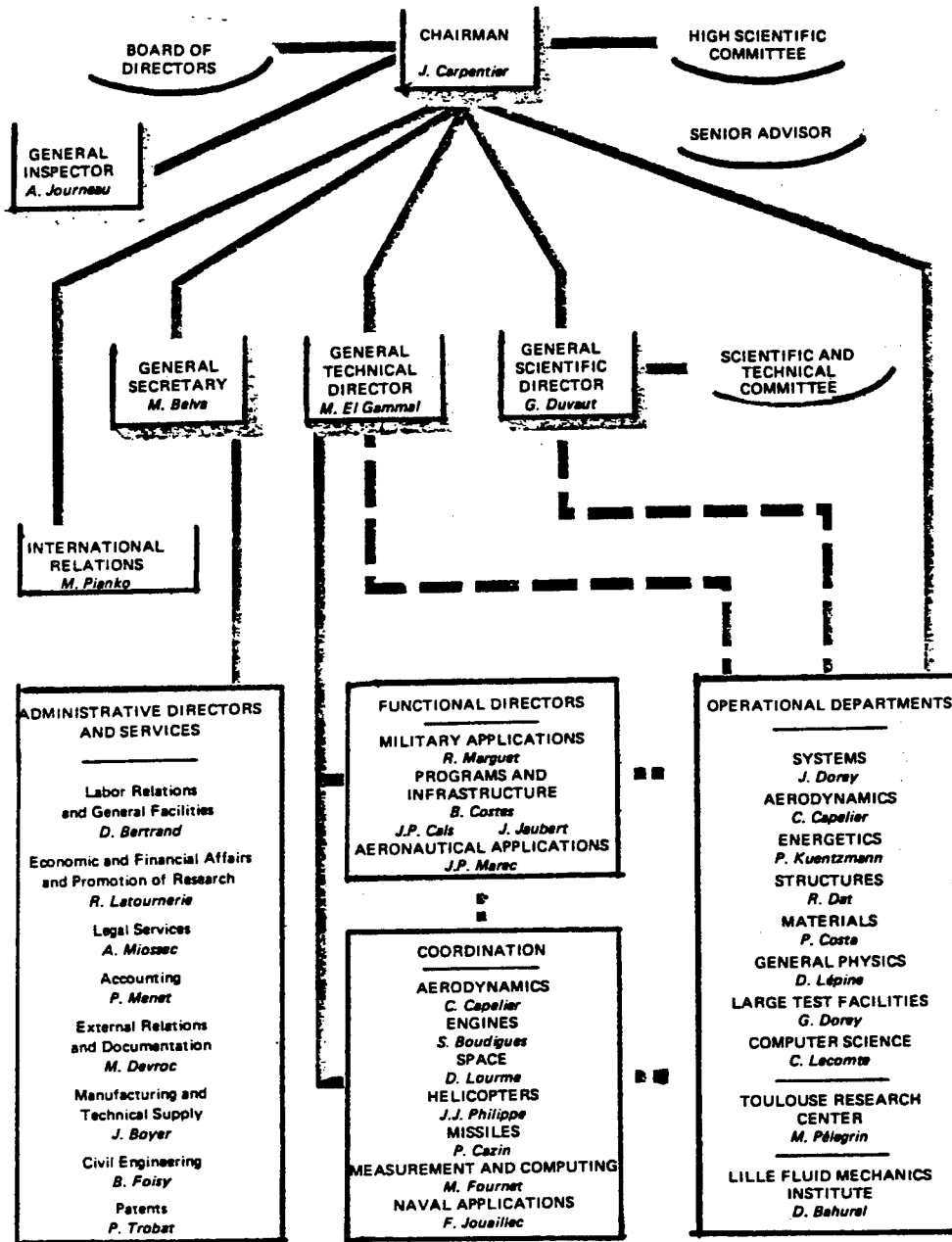

- I.5. An Inverse Method for the Design of Cascade Profiles in Transonic Flow
- I.6. Computation of Sharp Leading Edge Separation by Viscous-Inviscid Interaction Method: Cascades in Unsteady Flow
- I.7. Computation of Supersonic Cascades by Viscous-Inviscid Interaction Methods in Steady Flow
- I.8. Computation of Complex Separated Flows by Viscous-Inviscid Interaction Methods: High Lift Devices and Stall

- I.9. Computation of High Velocity Flows by Solution of Navier-Stokes Equations: Application to Near Laminar Wake
- I.10. Research on the Prediction of Vortex Breakdown
- I.11. Fundamental Research on Passive Control of Shock Wave-Boundary Layer Interaction in Transonic Flow
- I.12. Experimental Analysis of a Three-Dimensional Transonic Channel Flow
- I.13. Research and Assistance Activities with the Water Tunnel

II. Applied Aerodynamics

- II.1. Laminar Flow Control
- II.2. Reduction of the Turbulent Skin Friction Drag on Transport Aircraft
- II.3. Experimental Study of the Effect of Sweep on a High Lift Wing
- II.4. Wing Design by Numerical Optimization
- II.5. Computation of Complex 3D Flows
- II.6. Helicopter Blade Flow Computed by a Full Potential Method
- II.7. Pressure Measurements on Helicopter Rotor Blade in S2Ch Tunnel Using Cyclic Pitch Variation Device
- II.8. Space Shuttle Computations
- II.9. Computation of Complex Configurations by a High-Order Singularity Method for Linearized Subsonic and Supersonic Flows
- II.10. Missile Wing Stall Limits

[Passage omitted]

Energetics Department

36980121 Chatillon OFFICE NATIONAL D'ETUDES
ET DE RECHERCHES AEROSPATIALES in English
Apr 88 pp 52-54, 78

Even limited to what it means in aerothermochemistry, the word "energy" covers a wide variety of fields and reflects the many activities of ONERA's Energetics Department, which is mainly concerned with the propulsion of objects through a fluid or vacuum.

The Activities 1985 brochure gave a few general accounts of long term projects. This year, we have preferred to place our emphasis on diversity, which is gathering importance with the growing proportion of contract work in ONERA's finances. The sixteen studies presented here belong to such a broad range of fields that the only way of classifying them is by reference to one of our three classical themes of activity:

- numerical simulation and modeling;
- experimental research;
- systems.

Three examples will first be given illustrating the continuing need for "modeling" today because of the inadequate speed of computers to simulate certain phenomena by complete computations. The first of these examples is the prediction of the real performance of a turbomachine using three-dimensional inviscid flow computation codes. By changing the way certain boundary conditions are expressed, the wall effects due to the viscosity and blade tip clearance can then be taken into account. We have been able to identify the characteristic coefficients of these formulas by tests, as the results obtained are very realistic.

The next example is the practical computation of the unsteady flows, periodic through one rotation, in a complete turbine stage. By changing the number of

blades and vanes slightly, equivalent periodic groups can be created with just a few blades. A thorough study of a concrete two-dimensional configuration shows that this approach can probably be extended to three-dimensional flow.

The third example consists of a modeling of erosive burning in solid propellants. Erosive burning is governed entirely by the behavior of the boundary layer along the combustion surface, which receives strong parietal injections and is the seat of chemical reactions in the premixing and diffusion flames. The current modeling requires full computation of the flow and is costly even though it is satisfactory. More refined models may provide a way of getting around this obligation without losing too much accuracy in the results.

We then go into the "numerical simulation" aspect of our activity with the computation of optimum propulsion system performance, which requires knowledge of the chemical composition of the fluid in motion, and assumed to be in thermodynamic equilibrium. The new COPPELIA code, based on the numerical search for the extremum of the Gibbs potential, has now replaced the old code established from 1960 to 1965, with its intricate initialization process.

One example showing how far the numerical simulation of reactive turbulent flows has come is the operation of a "swirling" afterburner combustor. This shows the ultimate that can be taken into account in local flow detail and the sensitivity of the simulation to the definition of the turbulence in the combustor inlet section.

The last example concerns the convective flows in cavities delimited by the fixed and mobile disks of turbomachines. The cooling of parts inside a turbojet is becoming a critical subject, yet classically this is done by flows that are poorly controlled and inadequately understood. The ICARE code predicts flows like these. Its results depend intimately on the turbulence model used. The CRETE test rig, specially suited to this problem, provides a great deal of instructive data which are qualitatively well-predicted by ICARE but which also show the need for in-depth studies of turbulence.

"Experimental research", which is the second major aspect of our research, includes the construction of new test rigs and the execution of measurements to promote our understanding of various physical phenomena. Here again, we will use three projects to illustrate as many aspects of this research.

The SETHI test rig constructed in 1987 is the first. This is used for very detailed study of the behavior of cooling films emitted from the surface of turbine blades, a field of study long limited to flat plates. The scale of the blades on the SETHI is of the order of five to one, to facilitate the investigations. From more than 200 measurements, the flow and thermal fluxes can be determined perfectly.

The second example is an instrument designed to provide a quick, reliable evaluation of the normal combustion rate for a propellant as a function of the pressure. A large grain of known "generator" propellant maintains a pressure level in the test chamber, not highly subject to any disturbance from the combustion of the small sample of new propellant, whose regression law is recorded by ultrasonics. A "degressive" grain of generator propellant can be used for a complete pressure scan in a single firing.

The third example retained here under "experimental research" is the study of the acoustical sensitivity of liquid-propellant rocket engine injectors. The test rig combines two techniques, one being to represent the tangential modes of instability of a real motor by the first longitudinal mode of a small rocket of appropriate length, and the other being to modulate the flow rate and measure the natural damping. This way, the effect of the type of propellant and injector design on the stability of the real engine in operation could be analyzed qualitatively.

Two experiments will then be described to give an idea of the possibilities of the laser diagnostics methods the Energetics Department uses. The first is the CARS method of measuring the temperatures of N_2 , O_2 and H_2 molecules in an ethylene-air premixing flame, for comparison with the mean temperature given by the Rayleigh diffusion. The results confirm the fundamental hypothesis that the temperatures of all the molecules are equal, reactive or not, so that the temperature with N_2 can be obtained simultaneously with the concentration of another species.

In contrast to the fundamental character of this first experiment, the analysis of the velocity field in a real centrifugal compressor is given as an example of the industrial application of two-focus laser anemometry. The tests, carried out on the RACE test rig of the Saclay propulsion systems laboratories (CEPr) under normal conditions of operation, included tightly spaced probings between the rotor circumference and the diffuser throat.

Other more conventional procedures of physical chemical analysis have been used to interpret the combustion of composite propellants with "energetic binder", or nitrargols, with very high performance but a rate of combustion that is difficult to control. By analyzing the behavior of the flames of combustion of the various constituents, it has been possible to identify the mechanisms controlling this behavior and to define additives and new compounds to reduce its pressure sensitivity.

Participation in systems studies is the final theme of Energetics activity we will describe here. Its importance is steadily growing, despite the lack of the staff we need to participate actively in industrial programs.

Four examples will be given from very different disciplines. The first relates to the chemical iodine laser, and more particularly to the production of singlet oxygen. Gradual improvements made in a bubble generator have demonstrated the possibility of multiplying the usual flow rates by ten, and the way has been opened to research into more compact generators.

The second example concerns the supply of fuel into a missile ramjet combustor. To optimize performance through a large flight envelope, the fuel has to be distributed differentially among the various injection sectors to maintain an optimum mixture in the recirculation areas where the combustion takes place.

The third example is the application of computation codes normally used for transonic flows in turbomachines, to the case of the supersonic turbines driving the cryogenic propellant turbopumps in the Vulcain engine. A new version of the turbine second stage has been defined with a twelve-percent gain in efficiency.

This long list ends with the test runs at the Fauga-Mauzac center on a 1:20 scale model of the Ariane 5 launch vehicle and its ELA3 launch pad. The purpose of the test was to evaluate the thermal and acoustical environment during liftoff, particularly as it concerns the exhaust flue and the amount of water injected.

This broad panorama shows how all of the knowledge and experience acquired in the various disciplines studied at the Energetics Department can be used in many varied applications. All of this research stresses the appreciation of reality in its full complexity, with the inevitable approximations that come into play in solving problems, rather than simplifying concrete cases down to the point where strict rules can be used to obtain solutions of little consequence in the short or medium term.

Leading Staff

Scientific Director	Serge Boudigues
Assistant Director	Pierre Larue
Assistant Scientific Director for Turbomachines	Pierre Duban
Assistant Scientific Director for Chemical Propulsion	Paul Kuentzmann
Scientific Assistant	Pierre Duban
Technical Assistant	Yves le Bot
Senior Scientists	Pierre Laval
	Guy Lengelle
	Pierre-Jacques Michard
	Claude Verdier

Contents

1. Prediction of Real Turbomachine Performance Using a Modified Euler Code
2. Recent Advances in the Computation of Periodic Unsteady Flows in Turbomachines

3. Erosive Burning of Composite Propellants
4. Computation of Propulsion System Performance
5. Numerical Simulation of Axisymmetrical Reactive Turbulent Flows With Tangential Velocity
6. Numerical Simulation of Turbulent Flows in the Annular Cavities Between Turbomachine Rotor and Stator
7. SETHI Test Rig
8. Method of Quick Evaluation of Propellant and Semi-propellant Kinetic Characteristics
9. Experimental Analysis of the Acoustical Sensitivity of Liquid-Fuel Rocket Engine Injectors
10. CARS Thermometry on N₂, O₂ and H₂ in a Premixing Flame
11. Laser Doppler Anemometry of the Velocity Field in a Centrifugal Compressor
12. Combustion of Composite Propellants with Energetic Binder
13. Improvement of Singulet Oxygen Production for Chemical Iodine Lasers
14. Improvement of Liquid Fuel Ramjet Performance by Continuous Injection Control
15. Contribution to the Design of Supersonic Turbines Driving the Vulcain Engine Fuel Pumps
16. Tests on a 1:20 Scale Model of the Ariane 5 on Its ELA3 Launch Pad

[Passage omitted]

16. Tests on a 1:20 Scale Model of the Ariane 5 on Its ELA3 Launch Pad (Aerospatiale Contract)

For many years, ONERA has been studying a model of Ariane and its launch pad, to evaluate the thermal and acoustical environment when the launch vehicle lifts off.

In 1987, some thirty tests were made in a series of programs, on request from the CNES and Aerospatiale, on the Energetics Department's Fauga-Mauzac test rig, as part of the research on the future Ariane 5 launch vehicle and the definition of the new ELA launch system.

The 1:20 scale model, built in the ONERA shops and with the help of outside companies, includes:

- a model of the Ariane 5 launch vehicles,
- a half-model of the ELA3 system launch pad,

—a gantry over the launch pad to support the model and simulate altitudes up to fifty meters,

—and a water injection system for the launch pad.

[Passage omitted]

The purpose of these tests, made in simplified "launch pad" configuration with a single P170 solid propellant booster operating, and without simulating the jet from the HM60 engine, was to vary the launch pad geometries in terms of different exhaust flue lengths and slopes, covered or not, and to vary the jet flow passage sections in the launch table, the altitude and water injection in the jet, and then measure:

- a) the acoustical pressures (near field) at the payload fairing surface and along the vehicle and boosters;
- b) the thermal loads exerted on certain parts of the launch vehicle and launch pad;
- c) the characterization of the far acoustical field induced by the noise sources identified in the exhaust flue.

The attenuation achieved by the injections of water into the jet flow in the launch table, simultaneously with or separate from water injections in the exhaust flue, is examined by comparing the sound levels obtained during a launch.

For each test, more than a hundred measurements are recorded on the launch vehicle, the launch pad and its environment, by a collaborative effort among the various services of ONERA, in which the Energetics Department controls the installation and analyzes the thermal problems, the Structures Department takes care of the near field acoustical problems and the Physics Department deals with the far acoustical field.

[Passage omitted]

The full analysis of these tests should make it possible to refine the geometry of the ELA3 launch pad to minimize the noise received at the upper part of the vehicle, in consideration of the attenuations provided by covering the exhaust flue and injecting water on and into the launch pad.

[Passage omitted]

Systems Department

36980121 Chatillon OFFICE NATIONAL D'ETUDES
ET DE RECHERCHES AEROSPATIALES in English
Apr 88 pp 82-84, 90, 93-94

The activity of the Systems Department concerns the multidisciplinary applied research of ONERA and, in particular, the study of new concepts and of aerospace-oriented systems.

This activity is mainly conducted under contract, in direct relation with government programs and manufacturers projects. It is clearly oriented toward military applications; the activity for civil applications remains modest in spite of the Hermes project and a slight increase in satellite activity.

The fields of research mainly include:

- flight control at high angles of attack, guidance and data processing for combat aircraft and missiles;
- the impact of thermophysical phenomena such as kinetic heating and icing on the mission of these vehicles;
- the integration of new concepts in preliminary missile projects and their evaluation by ground and flight testing;
- the development of the methods and apparatus associated with processing of array antenna signals;
- radar signature analysis and the attempt to achieve stealth;
- the evaluation of complex optronic systems.

The Department conducts theoretical and experimental work in these fields as well as work unrelated to applications to refine the analyses and open new prospects. This research mainly concerns aerospace mechanics, optimization, aerothermics, electromagnetism, signal processing, image processing and optical computation.

Certain of the activities of the Systems Department are conducted in collaboration with other scientific departments of ONERA, in particular for air-breathing propulsion and lasers and can lead to testing on a significant scale, in particular for missile firing or building of experimental radars and radar analysis stations.

A few of the most significant results obtained in 1987 are outlined below.

The research in aeronautics concerned maneuvers at a high angle of attack and the use of thrust vectoring for combat aircraft; also the development of a code for computing the impingement and growth of ice on an airfoil and infrared thermographic measurements in an icing wind tunnel.

As concerns strategic missiles, new progress was made in the robust guidance of missiles with poorly known aerodynamic characteristics or which vary considerably during flight.

For tactical missiles, earlier work led to the exploratory development of a missile with large altitude variations and air-breathing propulsion and, in another area, the evaluation of means for in-flight resetting of the navigation of a stand-off missile.

In the space sector, a program for optimizing the climb trajectories of a future launch vehicle was developed and orbit injection of geosynchronous communication satellites at high altitude over the European area was optimized. Sloshing tests in a spinning satellite clearly demonstrated the unstable configurations.

Evaluation of laser weapon systems is continuing in the perspective of a threat against our own missiles. For low and medium power lasers associated with lidars, aiming, propagation and signal processing work led to active infrared imaging tests which supplied very high quality images of a variety of targets at more than 1,000 meters.

In the area of radio detection, a prototype of pulsed radar with synthetic antennas, installed at the Mediterranean Test Center, was equipped with a real-time computer for target tracking. A prototype of an over-the-horizon radar has just entered the first phase of active development.

Progress was also made in the measurement and analysis of the radar signatures of targets, now possible in real time, in the laboratory and in the field in ground-air configuration. Airborne systems are in development.

The following pages illustrate a number of these results. It is recalled that a large share of the activity of the Systems Department falls under National Defense classification and that the research presented herein is only a glimpse of the total activity from which significant parts are missing.

Senior Staff Members

Director	Jacques Dorey
Assistant Director	Jean Fave
Assistant Director for Optoelectronic Systems	Gerard Garnier
Systems Experimentation Advisor	Jean-Claude Theodore
Scientific Advisor	Christian Marchal
Technical Advisor	Jacques Denis
Penetration Systems Advisor	Michel Staron
Aerospace Mechanics and Systems	Claude Aumasson
Thermophysics	Daniel Balageas
Radar-Sonar	Yves Blanchard
Radar Signatures	Joël Fritz
Missiles	Bernard Petit
Optronic Systems	Rene Jalin
Senior Scientist	Pierre Bertrand

Table of Contents

1. Performance of a Combat Aircraft with Thrust Vectoring
2. Optimal Orbit Injection of a Pair of Communication Satellites
3. Propellant Sloshing in Spinning Satellites
4. Robust Adaptive Flight Control
5. SILAHR Laser Imaging System
6. Infrared Thermography in Icing Wind Tunnel
7. Aerothermal Research Related to Atmospheric Reentry
8. Real-Time Measurement of Radar Cross Sections

[Passage omitted]

V. SILAHR Laser Imaging System (DRET Contract) [by J. P. Cariou and F. Bretaudeau]

Originally designed for studying the possibilities of detecting and tracking fast targets, the SILAHR (French acronym for High Resolution Active Laser Imaging System) demonstrated its capability for recognizing and identifying a variety of ground and air targets in 1987.

In its principle, the SILAHR imaging system consists of a CO₂ infrared laser beam ($\lambda = 10.6 \mu\text{m}$) focused on the space to be displayed. Each point of the field is scanned by raster type scanning, with the energy backscattered by each point measured on a single detector. This data supplies the reflectance image. At the same time, a heterodyne detector measures the frequency of the received signal, determining the radial speed of each point by Doppler effect. The result is a Doppler image of the speeds.

Integrated since 1986 in an operational compact field mode, SILAHR provides a reflectance image with a resolution of 200 points per line and a Doppler image at the video refresh rate in a field of 0.4 degrees by 0.6 degrees with a range above 1,500 meters.

Many recordings were made in 1987 on the optical base of Fauga-Mauzac on various targets, in particular vehicles on the ground, buildings, people and electric cables. The high angular resolution is demonstrated by the fine detail of the images obtained. Sixteen consecutive images (0.5 seconds) were averaged to smooth the instantaneous images with speckles specific to coherent imagers. The Doppler filtering shows only the mobile points of the image, which reinforces the contrast of the object against the background.

The SILAHR images are digitally processed by texture image segmenting tools, supplemented by a region agglomeration technique.

Segmenting is used to identify parts of the image with roughly the same occurrence patterns (histograms of parameters characterizing particular structures of the image). To achieve this, a correlation coefficient is computed between a so-called reference pattern and all the patterns occurring locally within the image. The homogeneous regions are then obtained by thresholding the image of the correlation coefficients and the process is reiterated with other reference patterns. This technique allows several parameters to be taken into account simultaneously (different spectral bandwidths, several sensors or several processing results).

The segmenting algorithm is automated by hierarchical sampling of the reference patterns within the image. This hierarchy is obtained by means of a parameter (norm of the local occurrence patterns) which is significant of the boundaries and which measures the local degree of variation of the signal in the image.

The segmenting process provides a relatively large number of regions, which do not necessarily have visual characteristics or which do not appear relevant. To simplify the results, the regions are agglomerated to eliminate boundaries between neighboring regions based on certain predefined criteria. This technique yields an image with simplified contours containing sufficient data to interpret the scene.

[Passage omitted]

The results achieved with the SILAHR system in 1987, by means of this processing, show the possibilities of active infrared imaging for moving target detection, recognition and tracking.

[Passage omitted]

VIII. Real-Time Measurement of Radar Cross Sections (STTE Contract) [by E. Clay]

For several years, the BRAHMS radar station has been used to analyze the Radar Cross Sections (RCS) of air targets. ONERA designed and developed a real-time processing system directly coupled to the microwave receiver of the measurement station, in order to be able to provide the users rapidly with the results of these analyses.

The radar signals are first digitized then transmitted to a parallel processor with a computation capacity of 30 Mflops. The processor also receives the range data from a tracking radar and calibration data (Figure 1) from a management minicomputer. The processing performed allows the RCS of an aircraft and its rotating parts to be computed once every 10 ms. The real-time measurement

result is used as feedback for the measurement parameters themselves (analysis bandwidth, dynamic range, repetition frequency) to optimize the analysis. The results are displayed in real time by showing the RCS on the video image of the moving target and by spectral analysis of the corresponding radar signal. The results are also stored in highly condensed form on magnetic tape.

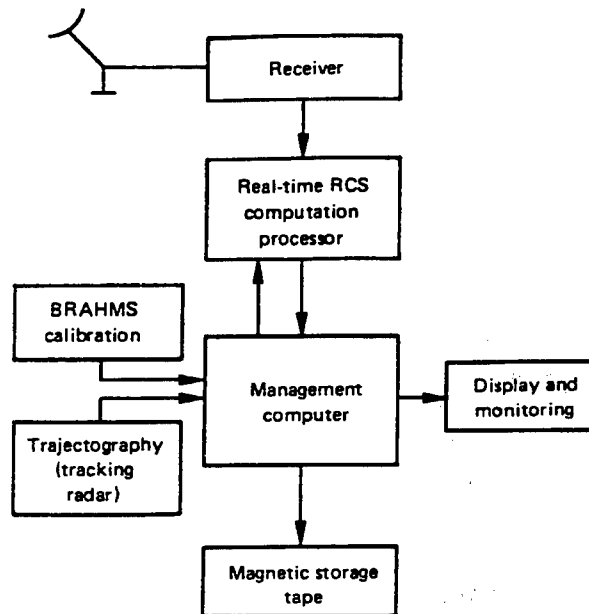

Figure 1. Real-time RCS computation system.

This equipment is operational on the Brahms I station for real-time measurement of the RCS of aircraft. It is planned to equip the station with a central management system including automatic moving target tracking, altitude resolution and other types of analysis.

[Passage omitted]

Large Testing Facilities

36980121 Chatillon OFFICE NATIONAL D'ETUDES ET DE RECHERCHES AEROSPATIALES in English Apr 88 pp 96-98, 103-104

As forecast in Activities 1986, the year 1987 was one of transition, when the industrial test workload for the Large Testing Facilities Department's wind tunnels did not reach the heights of previous years due to delays in the launching of the programs for the future fighter plane and the Airbus line (A 330 and A 340). These large programs brought in no appreciable workload before the second half of the year.

This was compensated for, to a certain extent, by numerous missile tests and major test programs on the air intake for the turbojet with high speed propeller, built by SNECMA and General Electric, in the F1 and S1MA wind tunnels.

The year 1988 is starting off very well for the wind tunnels, with an expected growth of tests for fighter planes and civilian transport aircraft, and a sustained workload for missiles. The overall volume of testing should again reach the satisfactory levels of 1986.

Leading Staff

CHATILLON

Director	Gerard Dorey
Assistant Director for Testing	Jacky Leynaert
Assistant Director for Engineering Programs	Jean Christophe Christian Soulier

MODANE-AVRIEUX

Head Testing	Jean Laverre Claude Armand
--------------	-------------------------------

LE FAUGA-MAUZAC

Head	Jean-Marie Carrara
------	--------------------

Contents

1. Tests on Airbus A330 and A340
2. Air Intake Tests in the F1 and S1 Tunnels for the "THR" Turbojet with High Speed Propellers
3. New Fighter Plane Afterbody Test Setup in the S2MA Wind Tunnel
4. Aircraft Gunfire Simulation Tests in S1MA Wind Tunnel
5. Tests of Aerospatiale Aster Missile in S2MA
6. Weighings of Swiveling Thrust Nozzles in the S4B Chamber
7. Hermes Space Plane Tests in S4MA Tunnel
8. Analysis of the Behavior in Crosswind of the Future "Pont de Normandie" Bridge
9. Wall Effects and Interactions of Supports
10. Use of Infrared Thermography at S2MA
11. Three-Dimensional Laser Doppler Anemometry in the F2 Tunnel
12. Initial Use of the New Helicopter Rotor Test Stand for the S1MA Tunnel

[Passage omitted]

7. Hermes Space Plane Tests in S4MA Tunnel (AMD/BA and CNES Contracts) [by J. P. Ledy]

In 1987 the first tests were run on a model of Hermes in the S4MA wind tunnel, in the tunnel configuration described in Activities 1986 (Figure 1). Let us simply recall that there is a filter between the pebble bed heater and the Mach 6.4 nozzle to remove the dust, coming essentially from the heater brickwork. This filter, diagrammed in Figure 2 [not reproduced], can be used up to 1,100 K. It has given entire satisfaction: the model is hardly blasted at all with sand and a great many blowdowns can be run before the filter cartridges are clogged.

presents such a comparison as concerns the effectiveness of the elevons and body flap.

The S4MA modernization work, on CNES contract, is continuing in 1987 with the order to Fluidyne for a cooled nozzle with an outlet diameter of 1 mm and a removable throat, producing at the outlet a flow at Mach = 10 or 12.

A new filter was designed for operation up to 1,500 K.

These new systems will be put into service in 1989.

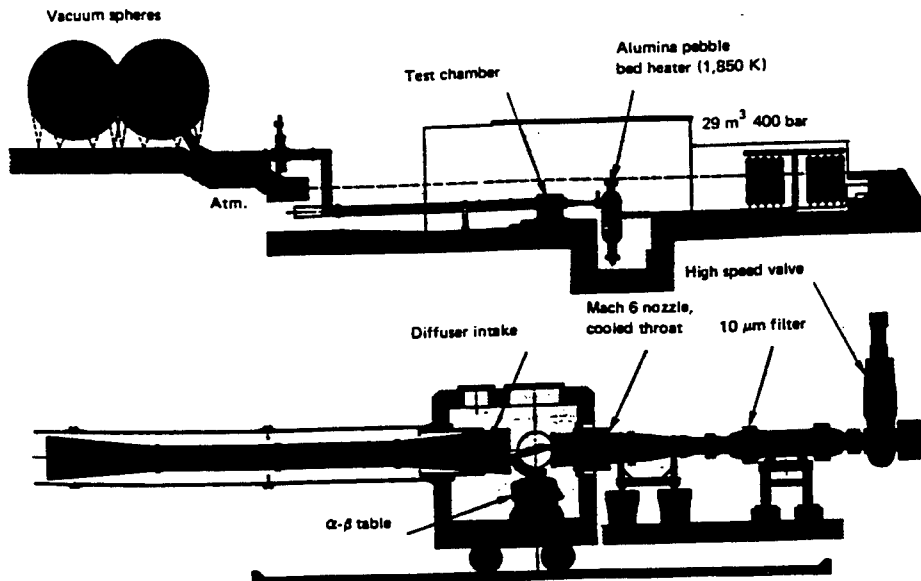

Figure 1. S4MA hypersonic wind tunnel (80403)

The Hermes tests were run under the control of a program written by AMD/BA, scanning angles of attack up to 50° and of sideslip up to 15°, to measure the global longitudinal and lateral coefficients and the hinge moments of the flight control surfaces. Skin visualizations were also obtained. An example is given in Figure 3 [not reproduced].

These tests were preceded by a few tests on a 1:120 scale model of the space shuttle Orbiter, for the sake of comparison with data published by Rockwell. Figure 4

[Passage omitted]

Materials Department

36980121 Chatillon OFFICE NATIONAL D'ETUDES ET DE RECHERCHES AEROSPATIALES in English Apr 88 pp 112-114, 124-126

The activities of the Materials Department are geared to the specific requirements of the aerospace industry. These include research into new materials and processes, the evaluation of the in-service performance of materials already widely in use, and the development of new physical methods for studying materials. The most important area of research relates to superalloys. This includes:

- alloys for single-crystal blades;
- studies on conventional power (equal to 100 µm), intended mainly for the manufacture of turbine disks;
- alloys derived from microcrystalline powders obtained at rapid solidification rates;
- methods of protection against oxidation and high-temperature corrosion, and studies of heat barriers.

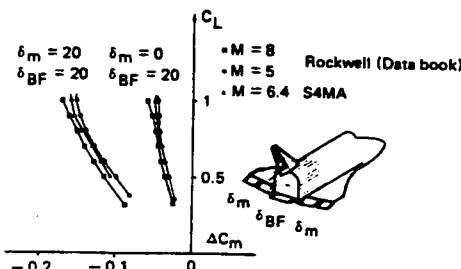

Figure 4. Orbiter: effect of elevon deflection (δ_m) and body flap deflection (δ_{BF}). (80412)

The purpose of light alloy research is to improve the in-service properties of known alloys. For aluminum, lithium alloys are being studied, along with rapid cooling of alloys from the liquid phase and carbon fiber-reinforced composites. For titanium, the work is aimed at developing powder metallurgy technologies, related new grades of alloys, new high-strength cast and forged alloys and silicon fiber-reinforced composites.

These metallurgical studies are supplemented by basic research in solid state physics: theoretical and experimental studies on the electronic structure of alloys, to shed light on the thermodynamics of concentrated alloys, and fundamental studies on the plasticity of metals.

Composites research involves ablative materials, ceramics, materials with specific electromagnetic or acoustical properties, and organic matrix materials. The main concern is the manufacturing techniques, but also the constituents (precursors of fibers and matrices, organic resins, carbon fibers), the strength characteristics and ageing (for organic matrices).

It should also be noted that the Physical Methods Division, which first introduced the electron microprobe, has since developed some new equipment extending the methods of material analysis, and is studying still other systems. This division recently undertook, jointly with the Universite de Paris-Sud, the study and construction of a secondary ion emission microprobe.

The Materials Department has extensive research facilities: in particular, three electron microscopes (100 kV and 200 kV, equipped for X-ray analysis, and the 400 kV CNRS-ONERA microscope), two scanning electron microscopes, several microprobes including a Camebax, many X-ray diffraction systems, all the necessary mechanical testing machines (tensile, creep, fatigue), various induction, arc and electron beam furnaces, powder production and hot-pressing equipment including one HIP vessel, analysis instruments (nuclear magnetic resonance, IR, UV and UV-vacuum spectrometry, liquid and gas chromatography), a wind tunnel-laser system designed for ablation measurements and a laser system for oxidation studies.

Leading Staff

Scientific Director	Paul Costa
Assistant Scientific Director	Robert Pichoir
Scientific Assistants:	
Applied Mathematics	Francois Girard
Metallurgy	Jean-Francois Stohr
Physical Methods	Bernard Daigne
Composites, Ceramics and Ablatives	Jean Jamet
Superalloy Castings and Rapidly Cooled Alloys	Tasadduq Khan
Senior Scientists	Bertrand Block
	Francois Ducastelle

Contents

I. Superalloys

- I.1. Anisotropic Tensile Behavior of a Single Crystal Superalloy
- I.2. Powder Metallurgy: Thermal Stability of Alloy N18 as a Function of Chromium and Molybdenum Content
- I.3. Determination of the Residual Stresses in Thin Layers of Oxidation Alumina
- I.4. High Temperature Corrosion Properties of Thermal Barrier Coatings

II. Titanium Alloys

- II.1. Development of a New Titanium Alloy for Compressor Disks
- II.2. Effect of Heat Treatments on the Properties of Ti-10V-2Fe-3Al Alloy
- II.3. Plasticity of Titanium Alloys with Dispersed Phase of Yttrine
- II.4. $TiAl_2$: A Reentrant Phase in the Ti-Al System

III. High Temperature Composites

- III.1. New Process To Elaborate Ceramic Composites
- III.2. Role of the Interface in the Chemical Properties of Monofilament Ceramic SiC/SiC Composites

IV. Metal Matrix Composites

- IV.1. Characterization of the Interface of Metal Matrix Composites Containing SiC Fibers

V. Resins, Fibers and Resin Matrix Composites

- V.1. Carbon Fiber Surface Treatments
- V.2. Modeling of a Micromechanical Test by the Finite Element Method
- V.3. Modeling of the Transverse Cracking Process in Cross-ply Composites

[Passage omitted]

III. High Temperature Composites

III.1. New Processes To Elaborate Ceramic Composites (DRET Contract) [by J. Jamet and M. Parlier]

ONERA is currently developing several ceramic composite shaping techniques applied to the thick three-dimensional structures of ceramic and carbon fibers. There are four such techniques and they concern respectively:

- 1) chemical vapor infiltration (CVI);
- 2) densification of fiber yarn, surrounded with ceramic glass by hot pressing;

- 3) infiltration and sintering of ultrafine powders;
- 4) organometallic process, i.e. injection of colloidal gel for oxides and pyrolysis of polymers for the covalents.

These different techniques were brought together in 1987 to develop new processes that would improve the quality of the matrices and reduce the manufacturing time. Of all these new processes, the first (CVI) is used only for the surface treatment of fibers in the fibrous preforms, to control the fiber-matrix interface, e.g. for CVI carbon.

Two new processes were thus studied:

- for oxide or covalent matrices, the infiltration of ultrafine powders of ceramic (process 3) followed by an overimpregnation of colloidal gel or polymer (process 4) to allow a greater densification and a lower consolidation temperature, which preserves the thermal stability of the fibers;
- for glass-ceramic matrices, the direct impregnation with glass in viscous state into the multidirectional fibrous structures during the hot pressing operation (extension of process 2).

These methods are of industrial interest insofar as they open new perspectives for the manufacture of complex shapes, in association with the latest industrial weaving methods, which call for shaping at a speed out of all proportion with that of the CVI techniques used elsewhere. The two following examples exemplify the application of these new techniques to three-dimensional SiC-Nicalon structures.

1) Manufacture of SiC/SiC/SiC Composite by Infiltration and Overimpregnation

The first example concerns the manufacture of a composite with covalent SiC matrix, chosen for thermomechanical applications. The infiltration consists of injecting a suspension of submicronic SiC powder (slip casting) in the three-dimensional substrate located above an ultrafine filter separating the powders from the suspension liquid. This injection is helped along by applying a rather low pressure between the free surface of the slip casting and the lower face of the filter. Once dried, the system is overimpregnated with polyvinyl-silane (PVS) in an autoclave. This polymer is a precursor of SiC matrix which was developed in cooperation with the IRAP (Institut de Recherche Appliquee sur les Polymeres) on the basis of acquired experience in this process, in the shaping of carbon-carbon composites. It is a thermosetting type resin with a very small mass loss (2 percent) during polymerization and a high mass efficiency of pyrolysis, of the order of 64 percent.

These resins have volume efficiencies after the ceramic conversion that are too small for them to be used alone. Associating them with the SiC powder, however, we get

a very homogeneous material with the following volume composition: 45 percent SiC Nicalon fibers, 25 percent SiC- β submicronic powder, 10 percent SiC from the pyrolysis of the PVS (after first impregnation). The mechanical properties of this material are very encouraging, in particular its toughness. The development of this type of process is being pursued actively at ONERA.

2) Manufacture of SiC/Glass-Ceramic Composites by Impregnation-Pressing

This method demands that four conditions be verified to ensure the thermomechanical quality of the composites:

- injection of a totally decrystallised glass in a viscosity domain between 100 and 1,000 Poises, which is typical for drawing glass fibers;
- maintenance of the mechanical performance of the fiber reinforcement under the thermochemical conditions of impregnation;
- control of the fiber-matrix interface to promote a nonbrittle failure mode of the composite;
- control of the germination and crystallization of the glass, in order to achieve minimum residual stresses (crystalline form) as well as good thermomechanical properties (grain size) for the matrix.

For the NLM 202 fibers of SiC Nicalon, research has recently shown that their thermomechanical survival could be extended up to 1,400°C for thermochemical treatment conditions in the strict absence of oxygen. This limit is compatible in particular with the viscosity law of the glass LAS Niobium SGR 6861.

The SiC Nicalon/SGR 6861 system had already been manufactured by other techniques (Activities 1986). As before, the diffusion of the niobium toward the carbon formed around the perimeter of the fibers at high temperature is essential in making an interface with satisfactory properties. At impregnation temperature, this diffusion works very quickly (in a few minutes). It leads to a highly dissipative failure while conserving 85 percent of the fiber strength ($> 1,875$ MPa).

This manufacturing technique has been extended to flat three-dimensional substrates of SiC Nicalon fiber (three-dimensional Brochier fabric type E 2319), 7 mm thick. The first pieces manufactured were composites with 45 to 50 percent volume content of fiber and porosities of 5 to 7 percent. Their failure stress in interlaminar shear mode is 20 MPa and better than 250 MPa in bending mode.

In sum, then, it appears that this mode of manufacture is applicable to the SiC/LAS niobium system, including for thick substrates. It makes for very fast manufacturing times (impregnation of 7 mm substrates in two minutes

at relatively low pressures (< 20 bar). Technological problems remain to be mastered to reduce the level of porosity and control the diffusion of the niobium.

[Passage omitted]

Computer Science Department

36980121 Chatillon OFFICE NATIONAL D'ETUDES
ET DE RECHERCHES AEROSPATIALES in English
Apr 88 pp 136-138, 141-147

The Computer Science Department is responsible both for implementing the central computation facilities and for research on new computer architectures and the applications of Artificial Intelligence techniques for the needs of ONERA.

In 1987, the Cray 1 S2000, placed in operation in October 1984 in the framework of the "Aeronautique" computer, was replaced by a Cray XMP 18. This facility is shared with several partners of the aeronautics industry. Aerospatiale/Avions, Aerospatiale/Engins tactiques, SNECMA and AMD-BA are connected by high-speed PCM lines and have direct access to the Cray (remote front-ending). Aerospatiale/Helicoptere, Aerospatiale/Engins spatiaux, Bertin and Turbomeca are connected by conventional leased lines and access the Cray through the central equipment of ONERA.

The transition from one computer to the other took place in June 1987. The new computer is approximately twice as powerful as the old one and has a main memory with 8 million words instead of 2 million (see Section IV, "Evolution of the 'Aeronautique' Computer").

In addition, as partner in the Cray "Recherche" GIE, ONERA has access to the Cray 2 of the Ecole Polytechnique. This computer includes four processors (somewhat slower than those of the Cray XMP) and has a main memory of 256 million words. During 1987, ONERA consumed slightly more than 1,100 CPU hours, representing 13 percent of the total consumption of the GIE partners and 7.5 percent of the global capacity of the computer (machine "saturated"). This computer is simultaneously accessible through the central equipment of ONERA from all the terminals connected to it and from the cluster of SPS9s of the Aerodynamics Department.

In 1987, the central computation equipment included two Control Data Cyber 170/855 computers which served several purposes:

- Support for more than one hundred interactive alphanumeric terminals assigned to users or freely available;
- Support for mid-range graphic terminals used under the same conditions;

- Provision of computation power to the users who do not use the vector computers;
- Access control endeavoring to satisfy the requirements of military security;
- Accounting of the work performed and generation of utilization statistics;
- File support (as file machine) for users of ONERA and certain industrial partners on the "Aeronautique" computer;
- Access to various central publishing facilities: laser printers, curve plotter.

Certain scientific departments substantially increased their number of workstations in 1987. In particular, the Structures Department acquired and placed in service some ten SUNs interconnected to each other and to the central equipment via Ethernet.

As concerns the IBM equipment supporting the CATIA software for CAD applications, there was a substantial increase in the workload in 1987, in particular for the needs of the Physics Department. This Department also decided to purchase an independent IBM workstation in 1988, which will however be connected to the IBM 4361.

The Research Division of the Computer Science Department conducts applied research in parallel computation and artificial intelligence. This research is carried out in collaboration with the Toulouse Research Center with the general aim of enhancing the interrelation between the results of computer science research and the potential needs which arise during the work conducted by the Scientific Departments of ONERA.

As concerns parallel computer architectures, the work conducted in the area of architectures with memory shared by the processors by means of a multi-AP system (Activities 1986) created several years ago at ONERA mainly led to:

- the production and use of an operational code for solving the Navier-Stokes equations corresponding to incompressible, unsteady real fluid flows around an airfoil for high Reynolds numbers ($Re > 10^5$);
- the production of a computation code on the Cray 2 of the CCVR based on a program developed on the multi-AP system (Activities 1986).

A perspective study on systems with a high degree of parallelism was undertaken based on an Inmos system with 40 processors; the results obtained and the evaluations conducted elsewhere led to focusing future research on this type of architecture (often called hypercube).

The research on Artificial Intelligence techniques concerned:

- extending the LEXAPO system (Activities 1986) to take into account discrepancies occurring during operator entries on the Computer Center computers;
- a preliminary study of a user aid system for a code computing the incompressible flow around a 3D body by the panel method;
- the continuation, in direct collaboration with the Computer Research Department of the Toulouse Research Center and the Aerodynamics Department, of production of an expert system for assistance in optimizing airfoils.

Senior Staff Members

Director	Claude Lecomte
Deputy Director/Computer Research Division	Michel Enselme
Computer Center	Jean-Pierre Peltier
Technical Deputy	Guy Hanuise
Production	Yves Goudedranche
Liaison	Jacques Zeyons
Implementation	Georges Stalin

Table of Contents

1. Implementation on the CRAY 2 of a Parallel Algorithm Based on Hybrid Formulation of the Equations of Linear Elasticity for a Composite Beam
2. Program Optimization on Distributed Memory Architectures
3. Study of Transputer Systems
4. Evolution of the "Aeronautique" Computer
5. Construction of the Ethernet Local Area Network at ONERA

[Passage omitted]

III. Study of Transputer Systems (STPA Contract) [by A. Cosnau]

In 1986, the parallel computation group undertook research on distributed machines with a large number of processors, also called massively parallel machines. In order to evaluate the problems raised by separating the memory and programming by message transfers and to test the possibilities of the transputer (a microprocessor which can be used as building block in parallel systems), a system of 40 transputers was installed in May 1987.

The system is the ITEM400 system of Inmos Ltd. which includes 40 T414 transputers distributed on ten cards and connected into a manually reconfigurable network by links. This set of processors is controlled by a host, a GOUPIL 40.

The transputers are microprocessors with the following main characteristics:

- Possibility of computation on 32 bits (or 64 bits for the T800).
- Each processor has four synchronized bidirectional links used to build complex networks of processors: rings, grids, hypercubes, trees, etc.
- Programming in OCCAM language used to build parallel applications consisting of concurrent tasks communicating by exchanging messages via channels.

Each processor has a 256-Kbyte external memory. At the beginning of 1988, the ITEM T414s will be replaced by T800s with a hard-wired 64-bit floating point coprocessor.

Although a machine with 40 processors cannot yet be considered massively parallel, it allows models of complex architectures to be built, the "numerical algorithm/architecture" adequation to be studied and gives a realistic idea of the software to be developed for such architectures.

Initial evaluations were made on the microprocessors which are the basic building blocks of the system and on the system itself:

- The T414, 32-bit transputer with programmed floating point processor;
- The T800, which is a T414 to which was added a hard-wired 64-bit floating point coprocessor, with the two units operating in parallel;
- The ITEM400 including forty T414 transputers (Figure 1).

These evaluations consisted of measuring the execution times for addition and multiplication of real numbers or integers, matrix-vector and matrix-matrix products using different algorithms on several networks (ring, grid, hypercube) as well as the communication times between processors.

It should be noted that for matrix operations, it was required that the global result be present in all the processors at the outcome of the computation and not only their local result. Figure 2 shows the curves of the ratios of execution time on one processor versus the execution time on several processors (speed-up) for the matrix-vector product on rings of processors of different sizes (where P is the number of processors, from 8 to 36). On this occasion was demonstrated the importance of the OCCAM programming style which allows the performance to be improved by a factor of two.

In a second phase, development was begun on utility type programs, in particular a multiplexer/demultiplexer. This utility, written in OCCAM, allows data to be transferred between several tasks distributed on two

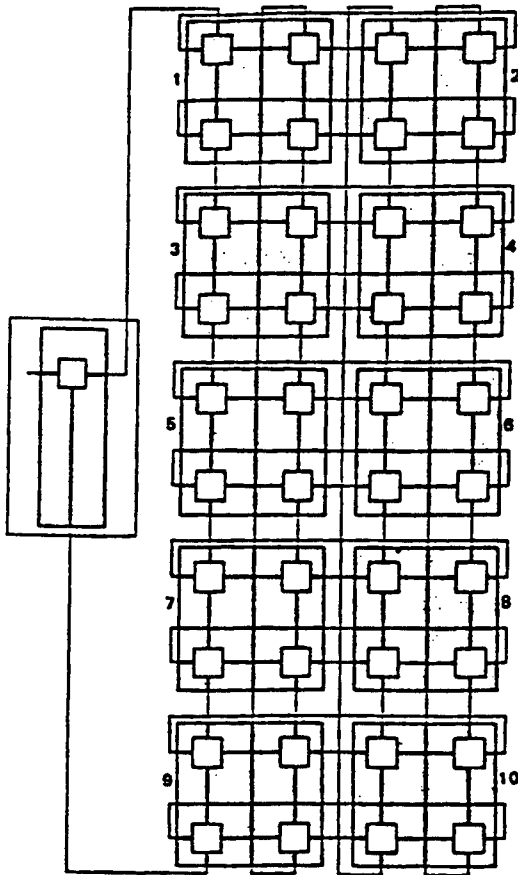

Figure 1. Standard ITEM400 network with 4 transputers per board.

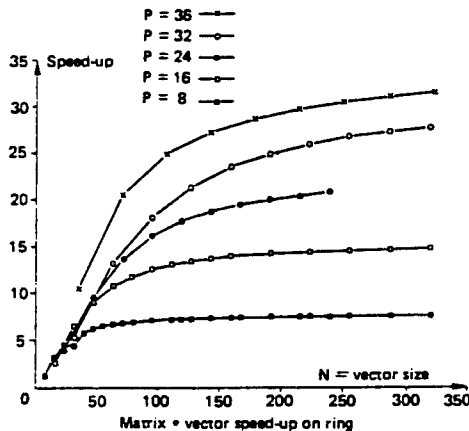

Figure 2. Curves of the speed-ups on various processor rings for the matrix-vector product.

transputers connected by a bidirectional physical link. The program can be considered as a logical crossbar network between two sets of tasks. It is planned to create other modules of this type.

A numerical analysis program is now being written. It concerns a structural dynamics computation problem solved by a finite element method and a numerical scheme. The kernel of the application, consisting of a block-tridiagonal system solving module using a preconditioned gradient method, is now nearing completion. This program will be implemented on a ring of 40 transputers.

More generally speaking, the objectives are to study the possibilities and problems related to machines with a large number of processors. It is attempted to find theoretical solutions to problems such as routing of the data through a network, detection and elimination of deadlocks, inputs/outputs, data and program allocation on the processors, the structural consistency of the data between the phases of an algorithm, global program management, dynamic network reconfiguration, algorithm/architecture adequation.

It was decided to validate the theoretical solutions chosen on numerical analysis applications, for which all levels of parallelism are used. In effect, such applications on very large sets of data are a good study support, as regards both selection or adaptation of an algorithm for a massively parallel machine and the computational solutions required to achieve the best computation time, satisfactory accuracy and identify a general methodology for parallelizing these applications.

To conclude, parallelizing applications on machines with a large number of processors appears to be a requisite for overcoming the limitations of today's computers. Many projects are under way in the world and intensive work has been engaged on these subjects. In 1988, this system will be used in particular to develop test programs which will be installed on the MILORD model produced by CERT by DERI/DERO.

IV. Evolution of the "Aeronautique" Computer [by Y. Gouedranche]

Vector Computer

In 1987, the Cray 1 S2000 was replaced by a Cray XMP18.

After being delayed by US manufacturing priority and license problems, the Cray XMP18 was received on May 25. It was placed in service in several stages which were concluded on June 22 by its availability for use by the industrial partners after switching out of the Transmic network. The Cray XMP18 has a memory capacity of 8 million words, i.e. four times that of the Cray 1 S2000. This new memory size, combined with a central processor 50 percent faster than that of the Cray 1 S2000, provides a processing capability two to three times greater.

Easier to use than the Cray 1 S2000 because of its input/output processors (IOPs) and with higher reliability because of its new technology, the Cray XMP18 allowed the computer center to supply the users (researchers of ONERA and industrial partners) with a better quantity and quality of service in a fully transparent manner.

Provision was also made for a backup system to transfer the file machine functionality to a second Cyber computer in the event of an interruption in the operation of the system nominally assigned to this task.

These configuration adaptations were completed at the beginning of 1988 by doubling the Cray/CDC links.

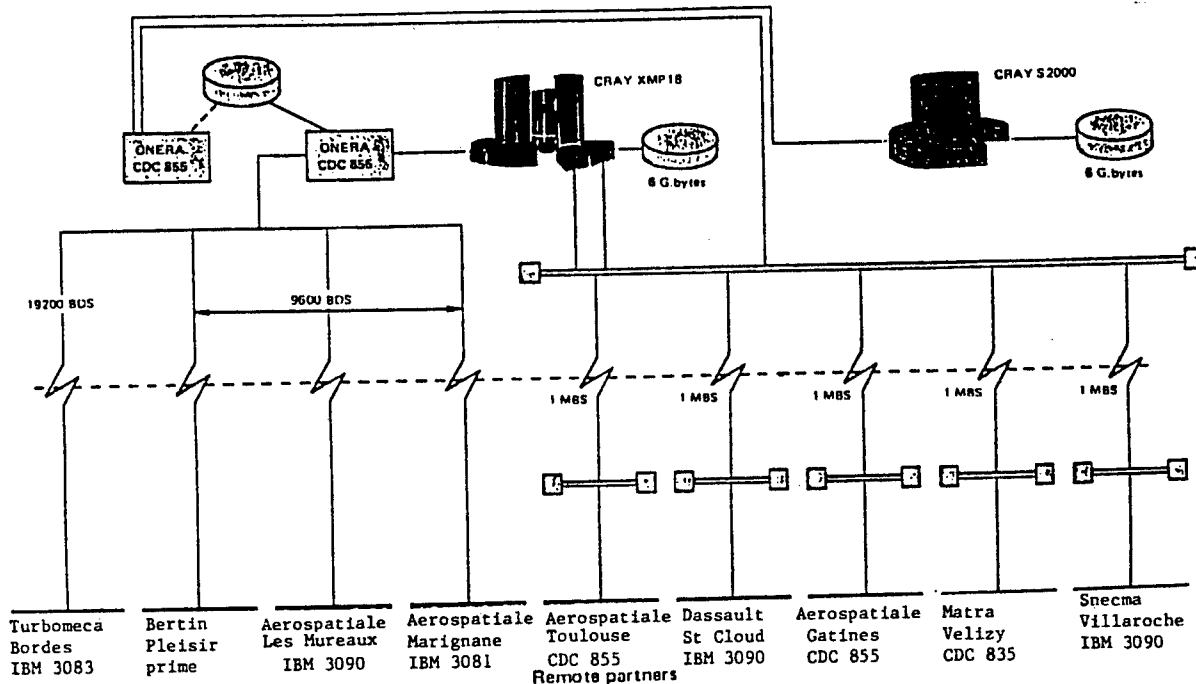

“Aeronautique” computer configuration at the end of 1987.

Because of this, the rate of use measured during the second half of 1987, expressed in CPU time of this XMP18, baptized “MAX”, was approximately twice as high as that of the first half of the year on the Cray 1 S2000 (a ratio of 1.5 was achieved under the conservative hypothesis of a speed variation inversely proportional to the clock period, i.e. $12.5 \text{ ns}/8.5 \text{ ns} = 1.45$; however, this acceleration applies only to the scalar part of the computations and the ratio of the vector speeds is higher than 2).

The surge in computation load which occurred in 1987 was made possible by the start of operation of a Cray 2 (four central processors, 256 million words of main memory) at the beginning of 1987 and by the evolution of the “Aeronautique” computer. These enhancements, which proceeded smoothly, allowed the production of 11,000 Cray1 S equivalent hours on the computer of the “Aeronautique” club for the entire year. This figure is far higher than the maximum production capacity on a fully saturated Cray1 S, evaluated at 8,000 hours.

File Machine

The file machine used by the industrial partners was also replaced at the end of 1987. Stopping of the Bull DPS8 Multics file machine led the club to transfer the local data storage function required by our industrial partners to a CDC Cyber computer. Functionalities as close as possible to those existing on the Multics were developed on the Chatillon Cyber computers to simplify the transition for the users.

It was necessary to adapt the input/output configuration of the Cybers to handle the corresponding increases in file and traffic volume.

It should be noted that at the end of 1987, the rate of use of the “MAX” XMP18 represented 80 percent of its maximum capacity. The date at which the new configuration will be saturated as was the Cray1 S will be the beginning of 1988. It is recalled that one of the vocations of the “Aeronautique” computer is to accelerate the design cycles for the manufacturers of this sector. It is therefore necessary to avoid complete saturation and the accompanying excessive response times, which requires surplus computation power. However, the existence of certain research work upstream, with less demanding requirements, can allow intensified use of the configuration and thereby increase its profitability.

V. Construction of the Ethernet Local Area Network at ONERA [by J. Zeyons]

Introduction

Trials on a "medium speed" Ethernet local area network, which began in 1986 after a preliminary study, made substantial progress in 1987 and led to the connection of this network to a large number of workstations of the Scientific Departments.

The aim of the network is to offer users with UNIX workstations a link with the central computers of the computer center in addition to conventionally networking the terminals. This allows them to access the following central facilities by means of interactive connections and file transfers:

- the "Aeronautique" Cray;
- the "Recherche" Cray;
- the central alphanumeric and graphic laser printer;
- file storage;
- a messaging system to which are connected some one hundred fifty terminals;
- the X.25 network set up during the previous years.

Technical Description

This network uses the TCP/IP program for data transfers. This program is available on practically all UNIX stations.

It is based on wiring of the Chatillon site started at the beginning of 1986 and which has been constantly extended since.

The Ethernet network physically consists of a main coaxial cable, called "backbone" to which are connected secondary cables called "laterals" to which the workstations are connected.

Certain workstations are however directly connected to the backbone cable for technical or geographic reasons, in particular the computer center equipment used for network supervision or acting as interface with other networks.

The Cyber central computers, front-ending the Crays and controlling the printers, were connected in two stages, supported by very different means:

- Connection through the X.25 network via a Data General MV 4000 station (also called Cyber 120), connected to the Ethernet network under TCP/IP and to the X.15 network (using the RHF software for file transfers with the Cyber).

This connection, which has been operational since the beginning of 1987, allowed the users already connected to the Ethernet network to communicate interactively and to transfer files with the central facilities by procedures developed at the Computer Center.

However, this temporary solution has the drawback of being relatively complex (nontransparent transit through the Data General station) and of a limited transfer speed due to transit over the X.25 network (maximum useful speeds of approximately 35 Kbit/s).

- To enhance the performance and functionalities of the connection between central facilities and workstations and taking advantage of recent work by Control Data in this area, the new CDC network, CDCNET, was installed at the end of 1987.

This network, also based on Ethernet, but using the CDNA-XNS software, which is different from TCP/IP, allows TCP/IP to be used for links between the Cyber and the UNIX workstations by means of a transparent interface between the two networks.

This last possibility, still being validated at the end of 1987, should be accessible to all the users at the beginning of February 1988 and benefit from an enhanced Cyber-Cray communication program.

Useful File Transfer Performance on the Network

Between UNIX Workstations

- 50 to 500 Kbit/s, if one of the machines does not have a native TCP/IP (for instance Apollo or Data General);
- 1 Mbit/s between SUN and/or SPS9;
- 1.4 Mbit/s between SUN and Silicon Graphics.

Between Cyber and Workstations

- 140 Kbit/s to a workstation;
- 330 Kbit/s to the Cyber.

These performance capabilities are the first to be measured and a substantial improvement can be expected in the near future.

Machines Currently Connected to the Network

Computer Center:

One SUN, one SPS9, one Apollo DN3000,
One Silicon Graphics IRIS 3130,
One Data General MV 4000, one CDCNET interface (GDI), one Hewlett-Packard network test and supervision unit;

Structures Department:

The SUN network (11 machines), one SPS9 and one Apollo;

Physics Department:

One SPS9;

Systems Department:

One Celerity 1230 and one Silicon Graphics IRIS 3030;

This network will be connected to the Chatillon network by a link defined in November 1987, supported by a high-speed Transmic line. With the state-of-the-art PROTEON routing equipment, the Chalais local area network will be able to be used as an extension of the Chatillon network transparent to the users.

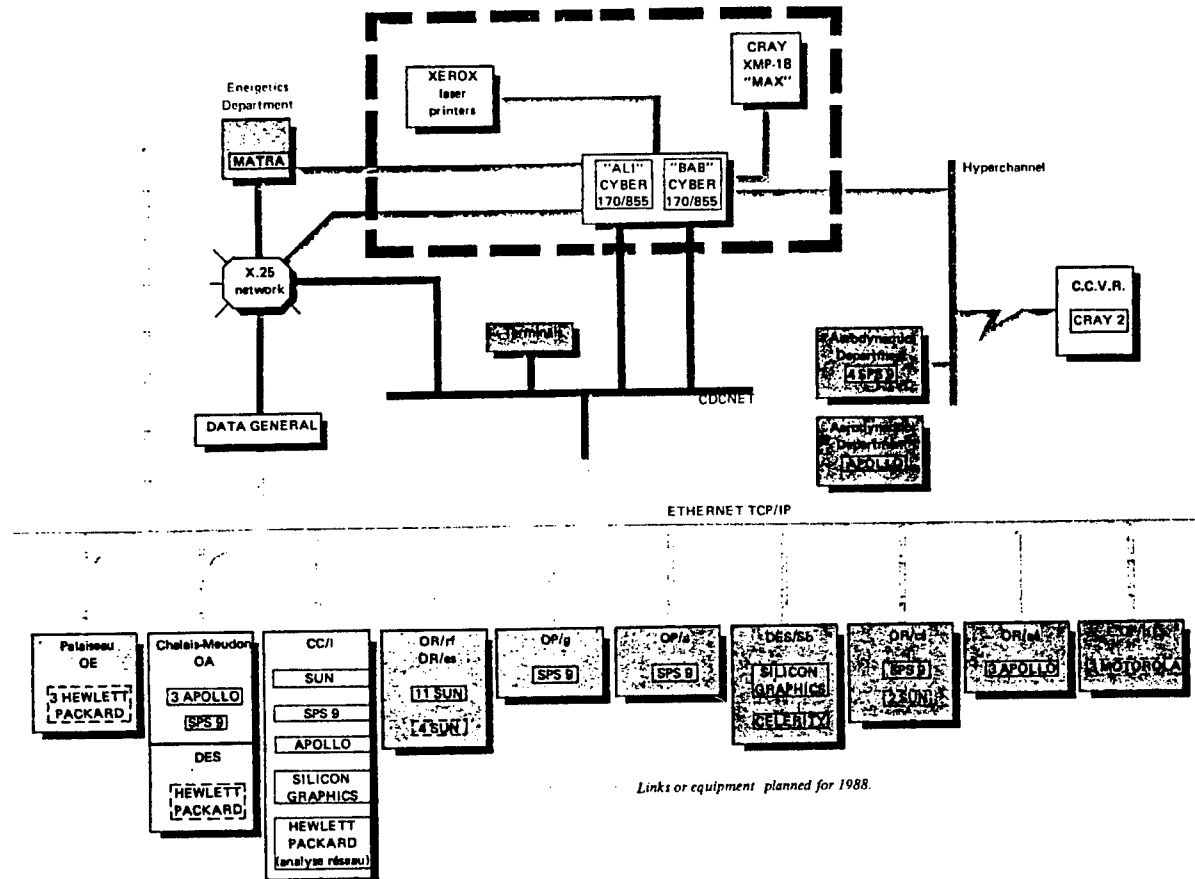

Links Between Workstations and Central Facilities in Chatillon at the Beginning of 1988.

Aerodynamics Department:

A special trial of connection of the SPS9s of this department took place in July 1987, and demonstrated the feasibility of this connection;

Energetics Department:

It is recalled that connection of the MATRA-NORSK-DATA computer of this department has been operational since 1986 by other techniques.

Workstations Being Connected

Chalais-Meudon

All the workstations of this center (Energetics Department and Aerodynamics Department) should be interconnected by an Ethernet local area network in 1988.

Palaiseau

At the request of the Energetics Department, a study allowed the same solution as for Chalais-Meudon to be defined. The general Ethernet network will thus cover all the ONERA plants in Ile-de-France at the end of 1988.

Conclusion

1987 was thus a year of intense activity in networking since, in addition to what was achieved for intermediate speed local area networks as mentioned above, actions on other types of networks were also continued, with a strong priority related to operational needs in certain cases. Among these can be mentioned:

- connection of the Fauga-Mauzac Center (CFM) to the central computers of Chatillon via the VAX 780 of the Large Testing Facilities wind tunnels (this connection uses the RHF program and is supported by Transpac);

- connection of TURBOMECA in Bordes, new industrial partner of the "Aeronautique" Club (connection supported by an IBM BSC 3780 protocol and a 19,200-baud digital line);
- extension of the X.25 network of ONERA;
- study of the high-speed connection of the Aerospatiale plant in Les Mureaux;
- improvement of the Aerospatiale Marignane connection;
- reorganization of the Chatillon part of the high-speed network of the "Aeronautique" computer to enhance reliability insofar as possible.

For a more distant future, the Computer Center actively participated in the "high-speed teleprocessing" study days where the suppliers (hardware and software manufacturers) met with the main users of supercomputers in France in a constructive dialog to reflect on the future of high-speed networks which are currently raising very serious problems of reliability of use, especially for long hauls.

Somewhat nearer in the future could be planned a reflection on the evolution of local area networks. The solutions implemented in 1987 and 1988 will undoubtedly give way to more performing, more standardized solutions capable of being managed and maintained in real time, as the availability of the networks determines that of the architectures of which they are increasingly becoming the vital links.

[Passage omitted]

Physics Department

36980121 Chatillon OFFICE NATIONAL D'ETUDES
ET DE RECHERCHES AEROSPATIALES in English
Apr 88 pp 150-152, 160-161, 165-166

The Physics Department includes a staff of engineers and physicists who conduct advanced research in scientific sectors conducive to promoting technical progress in civil and military aerospace and in certain other areas concerning defense.

A wide range of domains is represented in this Department. Its activity covers five major areas, corresponding to five research divisions: the Electronics and Measurements Division, the Optics Division, the Quantum Optics Division, the Acoustics Division and the Electromagnetic Environment Division.

The Electronic and Measurements Division develops new sensors for distance, pressure, temperature, thermal flux and acceleration measurements. It also supports the other Divisions and Departments in the areas of technology, electronics and signal processing.

The film sensor technique, in the process of being transferred to industry, is now widely used in naval and turbomachine applications. Electrostatic accelerometers will be used on board a dedicated satellite to measure the earth gravity gradient (GRADIO-ARISTOTELES project). At the end of 1987, this project was in the final phase of adoption by the European Space Agency.

The assistance to the other Divisions and Departments of ONERA was mainly materialized in 1987 by completion of development and the start of implementation of an original ultrasonic machining method, by a large contribution to defining certain concepts of the hybrid computer related to the RIAS radar and by the development of an initial module of this computer.

The Optics Division develops techniques aimed at improving the quality of images observed through natural atmospheric turbulence, either by digital processing of the images off line or, in real time, by applying adaptive optical techniques based on the analysis of the wavefront distortions and the use of a deformable mirror to compensate for these distortions.

Well versed in optical characterization methods for fluid flows, it was able to act very rapidly, at the request of CNES and SEP, to participate in solving the problem of ignition of the third stage of the ARIANE launch vehicle. To this effect, visualization systems were developed and implemented simultaneously on several test facilities. In addition, work was undertaken to adapt the visualization techniques to the new problems arising in the area of hypersonics.

The Optics Division is well known for its competence in the infrared spectrum. The main efforts are focused on analysis of the performance of multidetector elements, target detection under exospheric observation conditions, engineering of instruments for the Departments of the DGA (Ministerial Delegation for Armament) and the manufacturers: spectrophotometers, infrared scene simulators, spectral imager, etc.

The Quantum Optics Division includes researchers investigating the fundamental aspects of laser physics, laser spectroscopy, laser/matter interaction. This activity is developed around three separate themes:

- new laser sources;
- laser/matter interaction in pulsed state;
- Coherent Anti-Stokes Raman Scattering (CARS) and its applications.

CARS is an area in which the Quantum Optics Division has a leading international role. Beyond the basic research which has already given spectacular results in the area of detection sensitivity (resonant CARS), the Division's activity is focused on three main themes of application:

- velocimetry of gas flows;
- study of materials (CVD and nitriding);
- study of combustions.

The Division is also very active in the area of laser sources and pulsed laser/matter interaction. In collaboration with the Energetics Department, it is conducting basic research on the chemical iodine laser. It now has two pulsed laser sources designed at ONERA for interaction studies: one dye laser emitting a few tens of joules in the visible spectrum and a KrF excimer laser with an output of some 50 joules in the near ultraviolet spectrum. The test facility also includes a vacuum interaction chamber and diagnostic equipment allowing fine analysis of the physical mechanisms involved.

The Acoustics Division, which has long been working on improving aeroacoustics knowledge and methods, has devoted a large share of its effort to hydroacoustics in recent years. In these two areas, it characterizes noise sources and evaluates their far field radiation; one of the aims pursued is of course to reduce noise at the source.

This mission requires coordination between experimental and theoretical work and involves both fine-tuned measurement methods and sophisticated computation programs. All the signal processing resources must be put to use by this team for wind tunnel simulation and testing under live conditions; a special effort is therefore devoted to this discipline, with results that in some cases are spectacular.

The Electromagnetic Environment Division works on protecting aerospace vehicles against the hazards related to the aggressions of atmospheric electricity (lightning, static electricity for aircraft and launch vehicles) and exospheric charged particles (high energy electron precipitations for geostationary satellites). Its aims are to characterize the threat (in situ measurement campaigns), study the coupling of the electromagnetic radiations resulting from the phenomenon with the sensitive parts of the vehicle (electronic circuits, computers), define protective processes, devise ground simulation systems to qualify these protections and finally, provide data to prepare standards for the manufacturers on a technically reliable basis. This is a collective approach which involves both government organizations and manufacturers and in which ONERA is associated, in the fields of aircraft, helicopters, missiles, launch vehicles and satellites. The special responsibility of ONERA mainly concerns basic research on characterization of the phenomena and applied research on coupling; in the remainder of the program, ONERA mainly acts as expert and consultant.

Senior Staff Members

Scientific Director	Daniel Lepine
Deputy Scientific Director	Andre Girard
Deputy Technical Director	Jean Besson
Special Assistant	Claude Veret
Electronics and Measurements	Jean Appel
Senior Scientist	Jean Beaussier
Optics	Jean-Claude Fontanella
Quantum Optics	Jean-Pierre Taran
Senior Scientist	Daniel Pigache
Acoustics	Gerard Fournier
Senior Scientist	Georges Elias
Electromagnetic Environment	Jean-Louis Boulay

Table of Contents

I. Electronics and Measurements

- I.1. Capacitive Dimensional Measurement System
- I.2. New Ultrasonic Machining Process

II. Optics

- II.1. Optical Visualizations of the Two-Phase Oxygen Flow During the Starting Transient of the HM7B Motor
- II.2. A Posteriori Restoration of Images Degraded by Atmospheric Turbulence
- II.3. Apparatus for Characterizing the Optical Effects of Atmospheric Turbulence
- II.4. Photochemical Model of the Medium Atmosphere

III. Quantum Optics

- III.1. Chemical Oxygen-Iodine Laser
- III.2. Study of a Nitriding Plasma by CARS

IV. Acoustics

- IV.1. New Method for Extrapolation of the Acoustic Field
- IV.2. Location of the Noise Sources of a Helicopter Rotor
- IV.3. Acoustic Environment of the ARIANE V Launch Vehicle at Liftoff
- IV.4. Acoustic Propagation at Low Altitude

V. Electromagnetic Environment

- V.1. Study of the Discharges Initiated on the Surface of a Polymer Subjected to an Electron Bombardment
- V.2. Characterization of Storm Cell Electrization

V.3. Electromagnetic Fields Generated on an Aircraft During a Lightning Strike in Flight

V.4. Study of the Return Stroke Phase of Sliding Sparks

V.5. Penetration of Electromagnetic Fields Inside Structures Including Composite Materials

[Passage omitted]

III. Quantum Optics

III.1. Chemical Oxygen-Iodine Laser (DRET Contract) [by D. Pigache]

The oxygen-iodine chemical laser is a high power CW laser recently developed. It is the first electronic transition chemical laser and its wavelength of 1315 nm, located in the near infrared spectrum, is the shortest ever achieved by purely chemical means.

The pumping mechanism of the upper laser level $I^2P_{1/2}$ is based on a quasi-resonant transfer from oxygen excited in singlet state to atomic iodine:

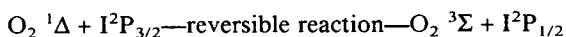

The singlet oxygen is produced by the reaction:

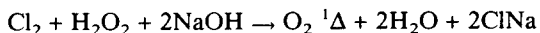

which occurs at the gas/liquid interface. The iodine is then mixed with the singlet oxygen. The operating pressure is approximately 1 to 2 torrs.

The advantages of the oxygen-iodine laser are:

- the possibility of achieving very high CW laser powers by purely chemical means: a level of 4 to 5 kW has already been reached in the USA and there are projects for several tens of kW;
- an advantageous wavelength: short with respect to the HF/DF chemical laser, corresponding to a very good atmospheric propagation window and compatible with laser beam transport by optical fibers.

A laser power of 150 W was achieved at ONERA in 1985 and a 1 kW laser is now being built.

It should also be noted that one of the main difficulties encountered in engineering a performing oxygen-iodine laser is to rapidly obtain a sufficiently homogeneous mixture of iodine and singlet oxygen. This is why it was initially attempted to model the mixture in the simple case of a coaxial geometry. The model is based on a combination of the chemical kinetics of the excited oxygen-iodine system and fluid mechanics with molecular and atomic diffusion.

Figures 2 and 3 [not reproduced] show the radial velocity profile and concentration profile respectively, computed for various distances z along the flow. It can be seen that the gas viscosity redistributes the velocity within a few centimeters, the singlet oxygen is entirely consumed at the edge of the iodine jet, the molecular iodine is only slightly diffused beyond the radius r_0 of the injector and is progressively replaced by atomic iodine. Computation of the population inversion, equal to $[I^2P_{1/2}] - 0.5 [I^2P_{3/2}]$, shows a region of strong absorption within the iodine jet, surrounded by a region of very low gain. This situation, obviously unfavorable to the laser effect, illustrates the necessity for a mixing apparatus more efficient and faster than the one that was modeled.

[Passage omitted]

IV.3. Acoustic Environment of the ARIANE V Launch Vehicle at Liftoff (Aerospatiale Contract) [by L. C. Valdes]

The acoustic loads associated with liftoff of modern launch vehicles reach high levels, often critical for the mechanical strength of the launch vehicle parts and payload and for correct operation of the electronic and electromechanical systems. It is particularly important to estimate these loads during the design phase, since they can affect the technological solutions chosen.

At the request of CNES and Aerospatiale, the Acoustics Division participated in the measurements conducted in 1987 on a 1:20 scale model of the ARIANE V launch vehicle and its ELA3 launch pad at the Fauga-Mauzac Center of ONERA. Its purpose was to collect the relevant data for a launch vehicle acoustic environment prediction code. The experimental data to be collected were intended to be used to characterize the noise sources in terms of the emitted acoustic power, the spectral distribution of this power and the spatial distribution in the jet.

An initial measurement configuration in which the microphones were located approximately 6 m from the launch vehicle provided the measurements designed to determine the radiated acoustic power and its spectral distribution using a finite element type integration method. In a second configuration, the microphones were located on a linear array 3 m from the jet. Analysis of these measurements by array processing supplied the distribution of the sources along the jet.

The results obtained using these two methods provided much new information of a fundamental and technological interest. Among this information can be mentioned the increase in radiated power with the launch vehicle altitude, at least up to a simulated altitude of 50 m, the substantial contribution of the jet/launch pad interaction, the location of the sources. After confirmation, in particular as concerns location of the sources, it will be possible to use these results to predict the acoustic field of ARIANE V at liftoff.

[Passage omitted]

Structures Department

36980121 Chatillon OFFICE NATIONAL D'ETUDES
ET DE RECHERCHES AEROSPATIALES in English
Apr 88 pp 174-176

Structural research is mainly aimed at improving the methods used to predict the behavior of aerospace structures in their particular environment. This aim requires research in structural mechanics and damage mechanics as well as very thorough analyses of the environments considered and their coupling with the structure. This is why unsteady aerodynamics has a large place in the program of the Structures Department.

Structural Mechanics

The activities described under this heading cover a relatively wide area extending from the analysis in post-buckling of unstiffened composite panels to fluid-structure couplings outside the low frequency domain, such as those concerning the statistical energy analysis of structures coupled with dense fluids at high frequency.

Aeroelasticity

In spite of the progress made in transonic flow computation methods, a large, sustained effort is still required for evaluation of the unsteady aerodynamic effects. The results relative to the method of small transonic 3D perturbations and solving of the Euler equations are given herein.

For helicopters, significant progress was made in predicting the aerodynamic loads on a rotating blade with wake effect.

Finally, based on the experience gained in studying the aeroelasticity of unprofiled structures, the Structures Department experimentally studied the dynamic stability of the future bridge of Normandy and participated in defining the section shapes.

Concerning turbulence, the activities relative to modeling turbulence and the response of aircraft led to development of a model of the atmospheric boundary layer in the 0-300 m segment, as well as to prediction of the Nord 260 aircraft response taking flexible modes into account.

Damage Mechanics

This area concerns research on fatigue, creep, crack propagation and the various forms of damage of materials and composite structures.

The behavior and failure of the structures are predicted by associating material behavior and damage models, whose coefficients are identified by experiments on elementary structures, with structural computations by finite element or integral equation methods.

As regards materials and composite structures, the research concerning coupling between compression and delamination of plates as well as the transverse cracking phenomena are described herein.

During research on monocrystalline alloys for turbine blades, an optimized identification test program was defined, giving information on the coefficients and functions characterizing the behavior of the material through a small number of tests.

The work on cracking under operational loads was concluded by a synopsis of the capabilities of the ONERA model. As for the research relative to damage, it is illustrated by results concerning the nonlocal approach to diesel engine cylinder head damage and lifetime predictions.

Senior Staff Members

Scientific Director	Rolland Dat
Assistant Scientific Directors	Jean-Jacques Angelini
	Roger Labourdette
Scientific Assistant for Structures	Henri Loiseau
Technical Assistant	Jean-Pierre Chaquin
Aeroelasticity	Christian Soize
Structural Mechanics	Roger Ohayon
Ground and Flight Vibration Tests	Gerard Piazzoli
Wind Tunnel Model Tests	Roger Destuynder
Environment	Alain Bourgine
Special Tests	Edmond Szechenyi
Strength and Fatigue	Jean-Louis Chaboche

Contents

I. Structural Mechanics

- I.1. Post-Buckling of Unstiffened Composite Plates
- I.2. Acoustic Vibrations of the Internal Cavity of an Experimental Ramjet
- I.3. Influence of Structural Complexity on Acoustic Radiation by Shells
- I.4. S.E.A. Approach of Structures Coupled with Dense External Fluids in HF

II. Aeroelasticity

- II.1. Theoretical Unsteady Aerodynamics: Computation by the Method of Small Unsteady Transonic 3D Perturbations
- II.2. Euler Equation Method Applied to a NACA 12 Biplane at Zero Incidence
- II.3. New Aeroelasticity Computation Codes for Helicopter Rotors
- II.4. Study of the Stability of the Future Bridge of Normandy in the Wind

II.5. Model and Simulation of the Atmospheric Boundary Layer in the 0-300 m Segment

II.6. Turbulence Response of the Nord 260 Aircraft

III. Damage Mechanics

III.1. Compression of Composite Plates with Delamination

III.2. Approach of Transverse Cracking in Laminated Composite Materials (Case of (0/90)s)

III.3. Prediction of Fatigue Crack Propagation in Structures Subjected to Service Loads

III.4. Tests of Monocrystalline Alloy CMSX-2 Under Complex Cyclic Loadings

III.5. Damage Mechanics and Local Approach to Cracking with a Nonlocal Damage Concept

III.6. Computation of Diesel Engine Cylinder Head Lifetime

[Passage omitted]

Toulouse Research Center

36980121 Chatillon OFFICE NATIONAL D'ETUDES
ET DE RECHERCHES AEROSPATIALES in English
Apr 88 pp 196-198, 200, 203-207, 211, 214-219

Senior Staff Members

Director	Marc Pelegrin
Administrative Director	Jean Lafon
Research Department Heads	
Automatic Control (DERA)	Marc Labarrere
Aerothermodynamics (DERAT)	Jean Cousteix
Computer Science (DERI)	Francois Regis Valette
Systems Mechanics and Energetics (DERMES)	Patrick Hebrard
Microwaves (DERMO)	Florent Christophe
Optics (DERO)	Daniel Bize
Space Technology (DERTS)	Manola Romero

Contents

DERA (Automatic Control Department)

I. Operator Assistant System for Remote Manipulation in Space

II. The PRODYN Real-Time Algorithm Tested on ZELT

DERAT (Aerothermodynamics Department)

I. Laminar-Turbulent Transition

II. Drag Reduction

DERI (Computer Science Department)

I. Numerical Analysis

II. Artificial Intelligence: Research and Application

DERMES (System Mechanics and Energetics Department)

I. Study of a "Vaporizer" Type Kerosene Injector Performance by Simulation

II. Infrared Imaging and C.A.D. Applied to Temperature Measurements

III. Analysis of Vortex Flow Meters in a Pulsatile Flow Condition

DERMO (Microwaves Department)

I. Dielectric Waveguide Phase Shifters

DERO (Optics Department)

I. Study and Characterization of the Optical Behavior of Micrometric Particles

II. Study and Correction of Residual Defects on SPOT Images

DERTS (Space Technology Department)

I. Electronic Components in a Space Environment

DERA

Highlights

In aeronautics, the quasi-automatic flutter test processing system developed by Aerospatiale Toulouse and to which DERA contributed in the definition and development of the processing algorithms is now operational. The system gave full satisfaction by allowing a considerable decrease in the duration of the A320 flutter test campaign.

The forced singular perturbation methodology was applied to missile guidance in collaboration with Aerospatiale. Substantial gains in range were achieved.

In the framework of design work on the Nuclear Aircraft Carrier (PAN), the free model is now operational and initial sea testing was conducted in August. DERA was closely involved in developing this free model and participated in:

—definition of the acquisition system;

—installation of filtering and data formatting programs;

—the production of the control algorithms required for experimental work;

—acceptance testing of the hardware and software.

In the area of production automation, DERA introduced three new products at SITEF 87:

—the OASYS workshop simulation program developed in collaboration with VALORIS;

—the OPAL shop scheduling expert system developed in the framework of the PROMIP GIP;

—the RCE force control robot developed in collaboration with AICO, consisting of a SCARA robot with an active wrist.

As concerns research on road traffic, the Toulouse Experimental Zone and Traffic Laboratory (ZELT) has been operational since the beginning of 1987. The first experimental work with the PROLYN algorithm was highly satisfactory and confirms the simulation results. In addition, the SIMAUT freeway simulation program, whose performance was improved, was selected by INRETS for its SIRTAKI computer aided freeway management system.

Much progress was made in research on modal control and original theoretical results were obtained in assigning eigenvalues by output feedback. In particular, methods were defined which extend the field of application of modal control. A robust, performing control law synthesis method was developed. It associates modal techniques for performance with frequency analysis of robustness. The results of this method applied to the flight controls of a helicopter are highly encouraging.

In the area of operator assistance, work was undertaken on remote manipulation in space. The aim was to design a system in collaboration with CNES to help the remote manipulator in a satellite gripping task. The model of this system, which uses the NEXPERT development program, was introduced at the last IJCAI congress where it was met with enthusiasm.

I. Operator Assistant System for Remote Manipulation in Space (CNES Contract) [by G. Boy]

Remote manipulation without direct vision is a task involving a large workload. In addition, the probability of anomalies and human errors is not negligible. The risk involved in abnormal cases of remote manipulation remains very high. Operator aid is crucial in this case.

The SAOTS (Operator Assistant System for Remote Manipulation in Space) project developed in collaboration with CNES was aimed at designing a system capable of detecting anomalies due to the environment, including the human operator, and analyzing them to determine recommendations for the operator or actions on the system to be controlled. The SAOTS system is based not only on functional knowledge of the system to be controlled but also on knowledge of how the system is used. The first type of knowledge can be characterized as deeper knowledge given by the remote manipulation system designers. However, the user knowledge can only be acquired through experiments.

The expert assistant system is represented by situational monitoring and situation recognition patterns and by inference rules for test and diagnostic. An incremental method was developed for knowledge acquisition and

refinement through experiment. This technique is particularly useful when knowledge in the area is scarce and incomplete as is generally the case for space applications.

To demonstrate the validity of the approach proposed, a model was developed on a microcomputer at DERA. This model is a milestone in the production of operator assistant software. It is now being installed in the CNES robotics laboratory as remote manipulation assistance for the HERMES robotic arm and industrial development is being considered in collaboration with DIALOGICS.

[Passage omitted]

DERAT

Highlights

- The work related to hypersonic flow counted for a large share in the activity of DERAT. For the HERMES space plane, boundary layer computation methods with air dissociation effects are being developed; techniques for solving the Navier-Stokes equations are also being developed to analyze the flow in the shock layer when the viscous effects are strong. The emphasis is again placed on taking air ionization effects into account in the boundary layers.
- The laminar-turbulent transition is another strong point of DERAT's activity. A variety of subjects are investigated: noise generated by transition, transition tripped by skin roughness on the HERMES plane, increased laminarity of aircraft wings, instability on a concave surface.
- Two aspects of the reduction in aircraft drag are investigated: using transition analyses to identify the factors contributing to the extension of laminar regions and using techniques for manipulating the boundary layers aimed at decreasing turbulent friction.
- The structure of 3D shear flows is experimentally studied in various configurations: flow around a wing-fuselage junction with a high sweep angle and high incidence on the upper surface; flow around an Airbus type fuselage (F1 and F2 wind tunnels); flow around a helicopter fuselage (F2 wind tunnel) in collaboration with Aerospatiale.
- Various types of unsteady flows were the subject of detailed experiments. Basic research was conducted on the pulsed boundary layer developing on a flat plate to characterize the influence of unsteadiness on turbulence production phenomena. The wake of an airfoil equipped with an oscillating flap was also studied. Finally, a preliminary analysis was conducted on the flow around a thin oscillating airfoil.

—In the area of the experimental study of transonic flows, extensive use was made of the T2 wind tunnel. The main research conducted in this wind tunnel relates to problems of buffeting and drag reduction.

A sustained effort was made to improve the techniques of use and measurement associated with the T2 wind tunnel. Thus, a three-component laser velocimetry facility is being considered to equip the wind tunnel.

In addition, the problems of wall correction and adaptation in transonic regime remain a decisive factor in achieving high-quality tests. Refined techniques for wing modeling were implemented during tests on the A320 wings.

[Passage omitted]

DERI

Highlights

In Numerical Analysis: startup of an electromagnetic computation activity. The Numerical Analysis Group (GAN) of DERI conducted activities on two themes in 1987, both based on approximation by finite elements.

The Fluid Dynamics Computation Theme

—The study of the Lagrangian approach, derived from the variational inequality in entropy, was developed through boundary condition problems from the theoretical standpoint and by rewriting the computation code including a more optimized solution of nonlinear systems from the algorithmic standpoint.

—The study of the "Galerkin" approach allowed the relationship with the variational inequality in entropy to be established. Two (2D) computation codes were developed. They gave satisfactory results for steady supersonic flows (using unstructured meshes).

The Electromagnetism Computation Theme

—The study defined in collaboration with the Systems Department (DES) of ONERA and the Microwave Department (DERMO) of CERT allowed the startup of this new activity. The program defined for a two-year period voluntarily covers a restricted aspect of the problem of target radar signature reduction: the aim is to calculate the RCS (Radar Cross Section) of a helicopter blade (3D aspect) including absorbent materials. The crucial theoretical problem is determination of the boundary conditions to be placed on the boundary delimiting the computation domain.

In Artificial Intelligence: a study was defined in close collaboration with CNES. It investigates the scheduling of space missions through two projects, that of the SPOT 4 earth observation satellite and that of the VESTA interplanetary probe. After identifying and formalizing

these scheduling constraints, the effort was focused on developing a methodology and tools associating techniques related to operational research extended by those of artificial intelligence (use of expert knowledge for solving conflicts). This work should lead to building two expert system models in 1988, for SPOT 4 and VESTA respectively. This work is actually only the first step in an ambitious research program which could even involve considering assistance in the execution of a space mission, possibly accomplished during a manned flight (HERMES), according to a problematic very close to that applied to assembly robotics and mobile robotics, i.e.: definition of a mission—generation of a plan of action—monitoring of execution—execution contingencies—amendment of the plan of action. This work is conducted in collaboration with DERA.

Other resources were devoted to a new theme, neural networks and connectionist models, first as participation of an engineer of the Department in a study trip to the USA organized by THOMSON-CSF/DSE during the first half of April 1987.

This study trip and bibliographical research led to the writing of a report: "State of the Art in the Area of Neural Networks." This was followed by participation in the course on neural networks organized during the first half of June. Finally, one connectionist model simulator was set up and experimented on the computer facilities of the Department: that of Rochester University (USA). At the same time, relations were established with several teams in France, Germany and the USA.

In Software Engineering: we participated in the CONCERTO project of CNET from the beginning to its conclusion in 1986. Certain developments considered a little over a year ago around the F1 formalism were not pursued. The team of the Department who worked on the CONCERTO project was assigned to two software engineering projects of the ESPRIT program, in which the Department is heavily involved: the TOOLUSE project which began at the end of 1984 and the REPLAY project which was started in February 1987.

Parallel Computation

The major activity which has been in development for approximately six years with DMI around the multiAP configuration of ONERA will be concluded this year.

This hardware and software tool, a genuine MIMD machine prototype, was the necessary experimental facility for the work conducted on programming of MIMD parallel machines: control languages (LESTAP, LC2, XANADU), supervision strategies, parallel algorithmics.

It can however be regretted that this tool was not more widely used by the scientific community involved in parallel computation research.

[Passage omitted]

II. Artificial Intelligence: Research and Application [by F. R. Valette]

The following activities were conducted in artificial intelligence:

- basic research investigating the problems of modeling of the reasoning process and its development, control of the reasoning mechanism, generation of negative explanations, expression of the mathematical language, learning by connectionist approach. This theoretical work is aimed at defining or improving the methods and algorithms;
- the development of tools, in this case the SYLOG system designed to be used for all problem solving applications and in particular for modeling expert systems. This system combines functional programming and logical programming, offering functionalities mainly centering on control, data structuring, rewriting rules;
- the production of applications—This work consists mainly of feasibility studies accompanied by the development of models or prototypes for experimenting and validation. The applications chosen are in aeronautics and space: airfoil design aid expert system (in collaboration with the Aerodynamics Department); mission preparation aid expert system for low altitude tactical flights (in collaboration with Matra); participation in a study by Aerospatiale concerning a centralized, airborne aircraft maintenance aid system; use of expert system techniques for space mission planning with application to the SPOT satellite.

Basic Research

a) Control of the Reasoning Process

Most PROLOG interpreters go through the search space (AND/OR tree) using a depth-first strategy with the possibility of backtracking in the case of failure.

Backtracking is carried out on selection points representing the goals satisfied and stored during the steps of the deduction process.

The selection points are chosen in case of failure in various ways:

- return to the most recent selection point—chronological, “naive” backtracking;
- selection of a backtracking point by analysis of the causes of failures occurring during the unification process—“intelligent” backtracking;
- choice of a selection point by static analysis of the data dependencies between the literals of the clauses;
- “semi-intelligent” backtracking.

Several methods were developed to handle “intelligent” backtracking. These methods are based on two general, dual approaches: that of Cox-Pietrzykowski-Matwin and that of Bruynooghe-Pereira.

Attempts were made to unify these two approaches and use their complementarity.

However, these methods are relatively complex and costly in time and memory space, which makes them inoperational in practice. In addition, these methods use concepts of minimal nonunifiable subsets (MNS) and maximal unifiable subsets (MUS). But they leave the problem of optimum choice of the MUS and MNS selection strategy “open”.

The method we propose is based on detection of all the unification conflicts (with the corresponding MNSs) each step of the solving process, by means of an “extended” unification algorithm based on solving a system of generalized equations called S-equations and representing the constraints to be unified. The MNSs thus computed then allow selection of the MUSs from which the solving process will be restarted. The MUS selection strategy uses dating of the nodes of the solution tree and the associated terms.

b) Generation of Negative Explanations

When a solution to a given problem is found using an expert system, it is possible to obtain a substantiation by traces and reports. A method was studied to provide information on nonsolutions, i.e. to answer a question of the type “why not $P(x_0, \dots)$?” asked by the user following an answer proposed by the solving system. This study follows on the development of a scientific program writer aid expert system model (recommendations relative to the use of numerical library modules).

The framework chosen was that of a knowledge base where the knowledge was formalized as predicate logic, restricted to Horn clauses. The method developed operates in two stages: determination of missing facts and reduction of this set using a technique of answer levels and additional information related to the pertinence (significance) of the answers to be constructed.

An Application: Space Missions Scheduling; Application to SPOT Satellite

The scheduling of filming by the SPOT satellite is a complex problem: a large number of tasks (request for photographs by SPOT-Image customers or for orbit segments by foreign ground stations) must be organized in time (i.e. on orbit segments) taking into account the possibilities of maneuver of the satellite (excursion of the mirrors) and conflicts resulting from the limited resources available on board.

Conventional programming techniques are poorly suited to this type of problem, lacking the required flexibility and interactivity. The solution proposed consists of associating conventional Operational Search techniques with newer Artificial Intelligence techniques to combine the rigor of mathematical analysis with the flexibility of reasoning.

The basic idea of this solution is to create an "intelligent" reasoning process avoiding blind searches, based on knowledge of the interaction between tasks. This idea, validated on the particular case of SPOT, can be extended to more complex problems, such as those raised for the future shuttles or space stations (taking into account of resources of any type and time-variable data).

DERMES

Highlights

Unsteady Fluid Mechanics

The particle path visualization, acquisition and restoring methods developed for 2D flows were generalized to 3D flows by a stereoscopic setup using two cameras and applied to various unsteady separated flows.

DERMES is heavily involved in the A3C operation (Concerted Combustion Chamber Action) with an initial approach concerning modeling of internal flows by LES + FCT methods (simulation of large eddies with corrected flux method). This approach was developed subsequent to a one-year study period at the NRL (Naval Research Laboratory, Washington) by an engineer of this Department.

In flow metering, in parallel with the continuation of work on the usual themes on disturbed flows (vortex flow metering, for instance), DERMES started two basic research activities in 1987 in the framework of international collaborations: EEC intercomparison, diaphragm flow metering with the GRI (Gas Research Institute—Chicago). This research, formerly limited to gas flows, was also extended to aerospace, in particular for applications to cryogenic flows.

Measurements

In acoustics, the acoustic imaging methods using intensimetry, initially developed for air experiments, were successfully extended to hydrodynamics and applied in particular to problems related to structural radiation. In addition, work was continued on the influence of intense acoustic perturbations on the emission of coherent structures and on the mechanism of atomization downstream of injectors.

In the area of visualization, object tracking and image processing, the competence of DERMES continued to be successfully applied to a large variety of areas: tracking and control of models in tanks, movement of the flexible seals on a surface effect ship, evaluation of the volume of cavitation voids.

New applications were also initiated: equipment of the vertical wind tunnel of IMFL with model tracking facilities, measurement of the vacuum rate on hydrojet, etc.

This activity, developed in the visible range, was successfully extended to the infrared range in the framework of the A3C program in order to develop a method for locally measuring the heat transfer coefficients by active thermography, applicable to combustor elements.

Energetics

The interest demonstrated in experimental work on two-phase flows (granulometry, vaporization, atomization) was confirmed, in particular in the framework of the A3C program: study of the basic mechanisms related to the liquid phase.

The approach of DERMES, associating isothermal simulations with various models of the physical phenomena involved in combustors, continued to be successfully applied in the framework of new combustion chamber development programs. This approach was made possible by improving the representativity of the simulations (in particular by taking into account two-phase phenomena), as well as by improving the chemical kinetics in the framework of combined type models associating a modular zero-dimensional computation by assembly of combustors with a more local computation of certain flow regions by K , ϵ type methods.

Finally, as it had desired for several years, DERMES was able to begin an activity related to basic experimental research on a small combustion system in 1987.

[Passage omitted]

DERMO

Highlights

Activities were conducted in areas related to radar; the frequency bands concerned are mainly above 10 GHz. For each of the lines of research can be mentioned:

- Antennas and radiation: continuation of radar signature measurements in the W band on land vehicles; signature analysis of tank and aircraft models in anechoic chambers; automation of the corresponding measurement facilities was completed.
- Materials and measurement: development of a facility to characterize the radioelectric behavior of materials, covering the Ku band; consisting of two ellipsoidal reflectors focusing a plane wave on the sample

for a wide range of angles of incidence, it supplies parameters characterizing the plates of absorbent or dielectric materials in this frequency band.

- Detection systems: design and start of production of a series of instrumentation radars with very high sensitivity.
- Integrated devices: development of new concepts of phase shifters suitable for use in electronic scanning antennas; very satisfactory performance capabilities were demonstrated at 35 and 94 GHz.

[Passage omitted]

DERO

Highlights

The program defined in 1987 proceeded generally as planned, fully supported by the main contractors to investigate new areas.

Can be mentioned in particular:

- the production of the MILORD model (French acronym for Microprocessors Interconnected by Dynamically Reconfigurable Optical Links) and the collaboration with the Computer Department for this project;
- execution of the RADAC program (French acronym for Attitude and Deformation Recovery by Cross Anamorphosis) which will now enter its operational phase;
- close collaboration with aerospace and aeronautical partners to prepare future actions.

[Passage omitted]

II. Study and Correction of Residual Defects on SPOT Images (CNES Contract) [by X. Briottet]

The Optics Department participates as expert in the CNES "SPOT image quality" group. In addition to determining the on-board filming calibration coefficients, the role of the Department was extended to expertising the residual defects in the images after equalizing the sensitivities of the detectors in the CCD arrays. The defects are currently identified on images with high reflectance (desert) and low reflectance (water, forest).

Images with high reflectance exhibit, after standard radiometric correction (level 1A), a higher response on arrays 1 and 3 in channel XS1 (blue) than on arrays 2 and 4 for both HRV (High Resolution Visible) cameras.

It is recalled that filming in each band is on four CCD arrays with 1728 photodetectors each.

These discontinuities can easily be seen by naked eye and represent 1 to 3.5 percent of the average image signal.

The origin of these defects is not yet accurately known but is probably due to a spectral effect of the landscape (desert spectra very different from the spectrum of the scene used to equalize the array sensitivities).

Characterization of the phenomenon from some ten SPOT images of deserts allowed a processing algorithm to be defined in which the array interface equalizing coefficients γ_b are modified from determination of the discontinuity on each array interface.

The study is based on the following assumptions (Figure 1):

- The desert images consist of a set of quasi-uniform elementary zones;
- Two adjacent zones located on either side of an array interface have the same second-order statistical properties but differ by their average.

In Figure 1, the following definitions are used:

- A zone is a neighborhood of an array interface one of whose sides is adjacent to it;
- An LH zone Z (RH zone Z) is the Zth zone located to the left (right) of the array interface;
- A region consists of the pair including the LH zone Z and RH zone Z;
- A skip is the difference between means of an LH zone Z and an RH zone Z.

The method consists of calculating the average discontinuity along each array interface and for each channel from the average of the sorted skips corresponding to the different regions. This is done as the SPOT data are read onto the storage medium.

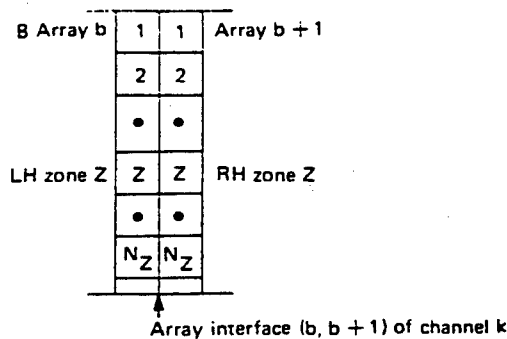

Figure 1.

To optimize the processing times, we did not use higher order statistics in each zone but preferred to carry out adaptive sorting on the elementary zones.

Calculation of the weighted average per zone uses the image data from a raw image (level 0). To determine the average in each zone, we must mandatorily work on corrected image data of level 1A.

The transition of the signal from level 0 y_{ibn} to level IA x_{ibn} is:

$$y_{ibn} = \gamma_b g_{bn} x_{ibn} + C_{bn}$$

where γ is the array interface coefficient relative to array b.

$$\sum_{b=1}^4 \gamma_b = 4$$

g_{bn} is the equalization coefficient of detector n of array b

$$\sum_{n=1}^N g_{bn} = 1$$

where $N = 750$ in multispectral mode and $N = 1500$ in panchromatic mode.

C_{bn} is the darkness current of detector n of array b.

[Passage omitted]

This algorithm gives satisfactory results in 80 percent of the cases.

Work is now being done to characterize the residual defects existing on water which are of another type, probably due to fluctuations in the additive part of this signal (darkness currents).

DERTS

Highlights

Space Environment

A major effort was made to evaluate radiations on low orbits. Data on solar eruptions and on cosmic radiation were analyzed. Studies were conducted in a European framework on the doses received at various levels by cosmonauts in Hermes, in a space station or during activities outside the space vehicle.

Electronic Components

An experimental setup has been designed and built for electrical homogeneity testing of semiconductor epilayers or semi-insulating wafers. Test samples can be characterized on a 3-inch wafer area with electrical probes at any temperature between 100 and 500 K.

Structural Materials

DERTS contributed with CNES to the analysis of the properties and use of materials of very low thickness to produce aerostats. The first application could be an exploratory planetary balloon on Mars.

The experimental array developed to sputter thin films on fibers used for hot composites gave good results. The metal oxide layers are effectively present on the entire wick and the production is sufficient to develop materials.

Coating Materials

The SEMIRAMIS space environment simulation installation for the "thermal control coating" application is operational and yielded measurements which were excellent by their detail and reproducibility.

The choice of a mode for correctly reproducing on the ground the orbital atomic oxygen as can be encountered between 200 and 1000 km of altitude was made and the equipment will soon be installed.

Electrization in a Space Environment

The work on degrading of solar generators by electrostatic discharges was completed.

A permanent short circuit was obtained on an "Olympus" type structure first subjected to bombardment by micrometeoroids.

Modeling of wake effects interested the European Space Agency and experiments were conducted in the large plasma chamber of PTS in Germany in the framework of the contract.

I. Electronic Components in a Space Environment (CNES Contract) [by D. Falguere]

The natural radiation environment existing in space near the Earth is detrimental to correct operation of the electronic components carried in space systems.

Various types of effects can occur. The "cumulated dose" effects are accelerated ageing of the component under the effect of the energy transferred to the material by the radiations penetrating it (dose). The nature and magnitude of the changes in the electrical characteristics depend on the nature, energy and intensity of the radiations as well as on the total dose. Another type of effect is the generation of transients in the components detecting electric charges, for instance photomultipliers, channeltrons in which the electrons of the Van Allen belts produce noise by avalanche, or again the changes of logic state caused by the impact of heavy, very high energy ions of the cosmic radiation in memories and microprocessors. This phenomenon has major repercussions due to the increasing trend towards on-board logic and the use of increasingly large scale integrated components sensitive to lower charge levels.

The activity of DERTS has two aspects:

- First, to proceed to qualification tests of electronic components of all types under irradiation;
- In addition, to improve the understanding of the phenomena involved in degrading of the semiconductor materials and components under the conditions encountered in space.

DERTS also participates in on-board dosimetry experiments using MOS structures (ERDOS experiments carried on SPOT 4) and evaluation of heavy ion fluxes (ERCOS experiment carried on the Franco-Soviet Long Duration Flight and on SPOT 4).

All this work is carried out in close collaboration with CNES.

1. Cumulated Dose Effects

Two main physical phenomena are at the origin of the degrading caused by cumulated doses:

- the creation of electron-hole pairs in the oxides and surface insulators caused by ionizing radiations;
- the creation of lattice defects (vacancies/interstitials) by the shocks between the incident particles and the atoms of the material.

The first of these phenomena is the most important. In effect, MOS technologies are highly sensitive to it because of their principle of operation, and these components predominate in on-board electronic equipment because of their low dissipation.

The irradiation facilities at DERTS include:

- two strontium⁹⁰ source irradiators which provide irradiation by electrons whose spectrum and intensity are very similar to conditions in space;
- two Van de Graaff accelerators, one used for electrons and the other for protons, allowing very high intensities to be reached where required with unique, well-known incident particle energy (to be set in 300 keV and 2 MeV);
- a cobalt⁶⁰ source chamber which supplies gamma radiations and which, although not representative of conditions in space, can be used for analyses in which the homogeneity in the dose in depth is required to satisfactorily understand the processes involved.

With the trend toward components performing increasingly sophisticated functions, the capabilities of the measurement facilities are becoming crucial, as is a full understanding of the test procedures. A particular effort was conducted jointly with CNES to develop performing characterization facilities. In 1987, a Sentry 15 VLSI tester was purchased. It allows dynamic, functional parametric characterization of all the digital components currently used in space.

2. Upset Effects (Changes of state induced by heavy ions)

The physical phenomenon at the origin of this effect is that along the trajectory of a heavy ion of cosmic radiation—which however induces only a very low overall dose—a cylinder with a small radius but irradiated at a very high level is generated, giving rise to a considerable concentration of charges.

As the cylinder size is comparable in magnitude to the size of the elementary cells containing the data as charges in VLSI components, changes of state (upsets) are generated. In certain cases, the currents involved are such that the spurious thyristor structure can be triggered, which can cause thermal breakdown of the component.

To study this phenomenon, a cosmic radiation simulation chamber was designed from a source of californium²⁵² which emits fission products causing energy transfer densities comparable to those observed in cosmic radiations when these products interact with the material. Ageing by cumulated dose can be carried out at the same time.

A memory tester was developed internally. The difficulty resides in the fact that a temporary, localized disturbance in the complex operation of these components must be measured dynamically and representatively.

3. On-Board Experiments

The ERDOS experiment uses MOS transistors with very thick gate oxide selected for their high sensitivity. It will allow continuous monitoring of the total dose received by the satellite with a resolution of approximately 0.25 Gy and checking of space environment simulations.

The ERCOS experiment consists of continuously observing the logical events on a set of memories. It should provide an evaluation of the fluxes of heavy ions.

During 1987, these facilities allowed some twenty types of components to be analyzed (diodes, transistors, prediffused circuits, DTC matrix, power MOS, memories, microprocessors, etc.) for the CNES and manufacturers involved in space projects.

The results comprise a substantial data base which had to be structured to account for the large variety in the functions and performance required of the components. In addition to acquisition and manipulation of the test results, a physical interpretation is of course made, if only to be able to substantiate the many simplifications required to pass from the description of a very complex space environment to practical, controllable specifications of an irradiation test on the ground.

[Passage omitted]

Lille Institute of Fluid Mechanics

36980121 Chatillon OFFICE NATIONAL D'ETUDES
ET DE RECHERCHES AEROSPATIALES in English
Apr 88 p 222

The highlights of the IMFL research activities in 1987 can be summarized as follows:

- Continued activity in cryogenics with, in particular, satisfactory tests in the T2 wind tunnel of a model designed and manufactured at IMFL, work for the ETW;

- New phase of the work coordinated by STPA on flight mechanics with the Alphajet aircraft in cooperation with the Systems Department (DES), AMD and the Flight Test Center. The methods developed at IMFL for modeling and predicting the behavior of an aircraft at high angles are now becoming operational;
- Conclusion of the work on air inlet/gun firing interaction, with satisfactory tests conducted in the Modane S1 wind tunnel validating firing similarity;
- Development of cooperative efforts with other Scientific Departments of ONERA: with the Structures Department (OR), the Materials Department (OM), CERT on masking materials, GME on carrier aircraft or the Nuclear Powered Aircraft Carrier, with DES on the maneuverability of aircraft at high angles of attack, with OR on flight control and turbulence.

Senior Staff Members

Director	Marc Pianko
Flight Mechanics	Robert Verbrugge
Structural Mechanics	Francis Dupriez
Fundamental Fluid Mechanics	Arthur Dymont
Applied Fluid Mechanics	Pierre Bailleux
Design Office and Shops	Marc Deschamps
Computer Science, Electronics, Acquisition	Alain Govaert

Contents

I. Flight Mechanics

- I.1. Prediction of Hydrodynamic Loads on Submerged Bodies
- I.2. Optimization of Fighter Aircraft Response to Vertical Turbulence
- I.3. Maneuverability of Underwater Bodies: Propeller Effect on the Steering Mechanism
- I.4. Analysis and Modeling of the Behavior of Fighter Aircraft in Lateral Gust
- I.5. Dynamic Pitch Behavior of Fighter Aircraft at Very High Angles

II. Structural Mechanics

- II.1. Cryogenic Technologies
- II.2. Characterization of Transverse Isotropic Composite Materials

III. Fundamental Fluid Mechanics

- III.1. Base Drag Reduction by Vortex Emission Using Cavities
- III.2. Porous Walls for Transonic Wind Tunnel

IV. Applied Fluid Mechanics

- IV.1. Unsteady Flow Measurements on Circuits
- IV.2. Automated Calibration of Anemoclinometric Probes

10

22161

31

NTIS
ATTN: PROCESS 103
5285 PORT ROYAL RD
SPRINGFIELD, VA

22161

This is a U.S. Government publication. Its policies, views, or attitudes of the U.S. Government. Users of this publication may cite FBIS or JPRS provided they do so in a manner clearly identifying them as the secondary source.

Foreign Broadcast Information Service (FBIS) and Joint Publications Research Service (JPRS) publications contain political, economic, military, and sociological news, commentary, and other information, as well as scientific and technical data and reports. All information has been obtained from foreign radio and television broadcasts, news agency transmissions, newspapers, books, and periodicals. Items generally are processed from the first or best available source; it should not be inferred that they have been disseminated only in the medium, in the language, or to the area indicated. Items from foreign language sources are translated; those from English-language sources are transcribed, with personal and place names rendered in accordance with FBIS transliteration style.

Headlines, editorial reports, and material enclosed in brackets [] are supplied by FBIS/JPRS. Processing indicators such as [Text] or [Excerpts] in the first line of each item indicate how the information was processed from the original. Unfamiliar names rendered phonetically are enclosed in parentheses. Words or names preceded by a question mark and enclosed in parentheses were not clear from the original source but have been supplied as appropriate to the context. Other unattributed parenthetical notes within the body of an item originate with the source. Times within items are as given by the source. Passages in boldface or italics are as published.

SUBSCRIPTION/PROCUREMENT INFORMATION

The FBIS DAILY REPORT contains current news and information and is published Monday through Friday in eight volumes: China, East Europe, Soviet Union, East Asia, Near East & South Asia, Sub-Saharan Africa, Latin America, and West Europe. Supplements to the DAILY REPORTs may also be available periodically and will be distributed to regular DAILY REPORT subscribers. JPRS publications, which include approximately 50 regional, worldwide, and topical reports, generally contain less time-sensitive information and are published periodically.

Current DAILY REPORTs and JPRS publications are listed in *Government Reports Announcements* issued semimonthly by the National Technical Information Service (NTIS), 5285 Port Royal Road, Springfield, Virginia 22161 and the *Monthly Catalog of U.S. Government Publications* issued by the Superintendent of Documents, U.S. Government Printing Office, Washington, D.C. 20402.

The public may subscribe to either hardcover or microfiche versions of the DAILY REPORTs and JPRS publications through NTIS at the above address or by calling (703) 487-4630. Subscription rates will be

provided by NTIS upon request. Subscriptions are available outside the United States from NTIS or appointed foreign dealers. New subscribers should expect a 30-day delay in receipt of the first issue.

U.S. Government offices may obtain subscriptions to the DAILY REPORTs or JPRS publications (hardcover or microfiche) at no charge through their sponsoring organizations. For additional information or assistance, call FBIS, (202) 338-6735, or write to P.O. Box 2604, Washington, D.C. 20013. Department of Defense consumers are required to submit requests through appropriate command validation channels to DIA, RTS-2C, Washington, D.C. 20301. (Telephone: (202) 373-3771, Autovon: 243-3771.)

Back issues or single copies of the DAILY REPORTs and JPRS publications are not available. Both the DAILY REPORTs and the JPRS publications are on file for public reference at the Library of Congress and at many Federal Depository Libraries. Reference copies may also be seen at many public and university libraries throughout the United States.