

259080

JPRS-UMA-86-035

9 JULY 1986

USSR Report

MILITARY AFFAIRS

AVIATION AND COSMONAUTICS

No 2, FEBRUARY 1986

19990211 053

DUPLICATE QUALITY INSPECTED 4

FBIS FOREIGN BROADCAST INFORMATION SERVICE

REPRODUCED BY
NATIONAL TECHNICAL
INFORMATION SERVICE
U.S. DEPARTMENT OF COMMERCE
SPRINGFIELD, VA. 22161

DISTRIBUTION STATEMENT A
Approved for public release;
Distribution Unlimited

10
66
A04

NOTE

JPRS publications contain information primarily from foreign newspapers, periodicals and books, but also from news agency transmissions and broadcasts. Materials from foreign-language sources are translated; those from English-language sources are transcribed or reprinted, with the original phrasing and other characteristics retained.

Headlines, editorial reports, and material enclosed in brackets [] are supplied by JPRS. Processing indicators such as [Text] or [Excerpt] in the first line of each item, or following the last line of a brief, indicate how the original information was processed. Where no processing indicator is given, the information was summarized or extracted.

Unfamiliar names rendered phonetically or transliterated are enclosed in parentheses. Words or names preceded by a question mark and enclosed in parentheses were not clear in the original but have been supplied as appropriate in context. Other unattributed parenthetical notes within the body of an item originate with the source. Times within items are as given by source.

The contents of this publication in no way represent the policies, views or attitudes of the U.S. Government.

PROCUREMENT OF PUBLICATIONS

JPRS publications may be ordered from the National Technical Information Service (NTIS), Springfield, Virginia 22161. In ordering, it is recommended that the JPRS number, title, date and author, if applicable, of publication be cited.

Current JPRS publications are announced in Government Reports Announcements issued semimonthly by the NTIS, and are listed in the Monthly Catalog of U.S. Government Publications issued by the Superintendent of Documents, U.S. Government Printing Office, Washington, D.C. 20402.

Correspondence pertaining to matters other than procurement may be addressed to Joint Publications Research Service, 1000 North Glebe Road, Arlington, Virginia 22201.

Soviet books and journal articles displaying a copyright notice are reproduced and sold by NTIS with permission of the copyright agency of the Soviet Union. Permission for further reproduction must be obtained from copyright owner.

9 JULY 1986

USSR REPORT
MILITARY AFFAIRS

AVIATION AND COSMONAUTICS

Number 2, February 1986

Except where indicated otherwise in the table of contents the following is a complete translation of the Russian-language monthly journal AVIATSIYA I KOSMONAVTIKA published in Moscow.

CONTENTS

Thinking Innovatively and Working in a New Fashion (pp 1-3) (L. Batekhin) (not translated)	
Political Indoctrination of Alert-Duty Fighter Crews in East Germany (pp 4-5) (Yu. Shevtsov)	1
Weapons Delivery Competition Between Transbaykal, Far East MD Aircrews (p 6) (V. Paramonov)	6
Clear-Cut Lines (p 7) (V. Dubrov) (not translated)	
Aviation Worker Trade Union Committee Activities (pp 8-9) (V. Kalosha)	10
He Confirms His Position With Deeds (pp 10-11) (N. Antonov) (not translated)	
For Power to the Soviets (pp 12-14) (S. Lisitskiy) (not translated)	
Good Shoots (pp 14-15) (V. Larin) (not translated)	

Forward Air Controller Wounded in Afghanistan (pp 16-17) (N. Stolyarov)	15
Fighter of the Revolution (pp 18-19) (V. Bilan) (not translated)	
Grandson of Revolutionaries (pp 20-22) (O. Nazarov) (not translated)	
He Went Into Battle as Flight Leader (p 23) (Z. Pogosyan) (not translated)	
Pledges Met (pp 24-25) (Not translated)	
Siberian Character (pp 26-27) (Ye. Podolnyy) (not translated)	
New-Generation Aircraft Bring Higher G Forces (p 28) (G. Glod and M. Khomenko)	21
Mi-8 Copilot Does Combat Tour in Afghanistan (p 29) (G. Korzh)	24
Current Realities and Malicious Lies (pp 30-31) (V. Ovsyannikov) (not translated)	
Aircraft Designer Antonov's Career Thumbnail-Sketched (pp 32-33) (A. Samoshkin)	28
History of Air-to-Air Combat Reviewed (continuation) (pp 34-35) (Yu. Kislyakov and V. Babich)	33
Training Pilots to Respond Correctly to In-Flight Equipment Malfunctions (pp 36-37) (N. Litvinchuk and V. Kozlov)	39
"I Cannot Conceive of a Different Destiny...." (p 38) (V. Grishukevich) (not translated)	
Winged Dynasty (pp 39-41) (V. Rudenko) (not translated)	
We Are Justly Proud (pp 40-41) (V. Gorkov) (not translated)	
First Soviet Spacewalk Described (pp 42-43) (M. Druzhinin)	44
Officers Recall Gagarin's Early Military Flying (conclusion) (pp 44-45) (N. Varvarov)	51
Soviet Balloon Sondes Probe Venusian Atmosphere (continuation) (pp 46-47) (V. Balebanov)	57

POLITICAL INDOCTRINATION OF ALERT-DUTY FIGHTER CREWS IN EAST GERMANY

Moscow AVIATSIYA I KOSMONAVTIKA in Russian No 2, Feb 86 (signed to press 3 Jan 86) pp 4-5

[Article, published under the heading "We Report to 27th CPSU Congress," by Col Yu. Shevtsov, first deputy political department chief, Air Forces, Group of Soviet Forces in Germany: "Following the Rules and Regulations of Alert Duty"]

[Text] Difficult, crucial duty beyond our country's borders sharpens servicemen's patriotic feelings. A high degree of political and labor enthusiasm is noted from the very first days of the new training year in aviation units and subunits of the Group of Soviet Forces in Germany.

Aviation personnel are pleased by the successes achieved by the Soviet people in the 11th Five-Year Plan. They are also inspired by the magnificent prospects for the further flourishing of our beloved homeland as specified in the draft new revised CPSU Program and Basic Directions of Economic and Social Development of the USSR For 1986-1990 and the Period Up to the Year 2000. Nationwide popular discussion of these documents, in which Air Forces personnel in the Group of Soviet Forces in Germany took active part, has become on the eve of the 27th CPSU Congress a vivid demonstration of the indissoluble unity of the party, people, and their Armed Forces, of the readiness and willingness of Soviet citizens to devote all their energies and resources to the great cause of building communism and reliable defense of the achievements of the October Revolution.

Carrying out their military and internationalist duty at the boundary between two worlds, figuratively speaking, in direct contact with one of imperialism's largest military force groupings, the men of our aviation units and subunits are constantly and continuously aware of the genuine danger presented by the aggressive preparations of the United States and its NATO allies. The true reason for the warmongers' criminal course of policy is profoundly articulated in the new draft revised CPSU Program. "The more the course of historical development undermines the position of imperialism, the more hostile to the interests of peoples becomes the policy of its most reactionary forces," stresses this document of enormous political importance.

NATO forces frequently hold exercises and maneuvers in the vicinity of the borders of the GDR, and provocational flights by reconnaissance aircraft are taking place on a virtually continuous basis. The aggressive forces of imperialism continue to count on the element of offensive surprise.

In these conditions command authorities, political agencies, party and Komsomol organizations of Air Forces units and subunits in the GSFG are doing considerable work among personnel, are teaching them to keep their powder dry, to be in a state of continuous readiness to thwart and repulse a sneak attack by the probable adversary, and are doing everything necessary to achieve further increase in the vigilance and combat readiness of personnel, and particularly on the part of alert-duty crews and duty-shift personnel.

Men were standing stiffly at attention in the ceremonial area of a certain aviation regiment. Among these men, who were about to carry out a mission, stood Military Pilot 1st Class Capt V. Mudrenov, holder of the Order for Service to the Homeland in the USSR Armed Forces, 3rd Class. The Soviet National Anthem was played. The official order to commence alert duty was read to the men. Aircrews and ground personnel, deeply cognizant of their personal responsibility for reliable defense of the peaceful skies of the homeland and the countries of the socialist community, proceeded to perform their assigned mission.

Not long before going on alert duty, the men of an excellent-rated flight took part in a tactical air exercise. Following the scenario prepared by the higher commander, crews became scramble-ready faster than the performance standard. The men of holders of the Order of the Red Star Capt S. Boldyrev and V. Ivanov performed with particular precision and smoothness.

Alert-duty subunit party group organizer Capt V. Mudrenov also began his work with a presentation dealing with front-runners in socialist competition in honor of the 27th CPSU Congress and their experience in the campaign to shorten the time required to make men and equipment ready to scramble. This party activist called upon aviation personnel widely to utilize in the course of alert duty the experience and know-how of the best pilots, technicians and mechanics, and to act with speed, determination, and competence in all situations. Promptly-produced news bulletin leaflets on the performance results of the first hours of alert duty also helped set such a mood and tone.

An efficient system of ideological and political indoctrination work has been established in GSFG air forces for the purpose of forming in commanders, political workers and all other personnel a heightened sense of forward line, an awareness of personal responsibility for ensuring that alert-duty personnel and equipment are at a high level of combat readiness. Aviation personnel are prepared at all times to intercept and destroy airspace intruders at the designated intruder intercept lines. The patriotic appeals "Remember the lessons of the war!" and "In the GSFG every training sortie could become an actual combat mission!" awaken a lively response in the hearts of the winged guards of our skies.

Party political work with alert-duty personnel and with crews is grounded on the men's thorough study of fundamental party documents, instructions by CPSU

Central Committee General Secretary Comrade M. S. Gorbachev on defense matters, and the demands of the USSR minister of defense, the chief of the Main Political Directorate of the Army and Navy, and the commander in chief of the Air Forces pertaining to combat readiness of alert-duty personnel, equipment and facilities and precise command and control of these assets. The link between party political work and the practical tasks of alert duty is becoming increasingly stronger today.

A certain guards fighter regiment in the GSFG air forces is rightly considered to be one of the finest in organization and conduct of alert duty. This is helped to a great degree by activist, purposeful efforts on the part of the command authorities, party and Komsomol organizations, and their endeavor to carry out each task in a prompt and timely manner and with high quality.

A detailed discussion was held at a party committee meeting on placing greater emphasis on the human factor -- an important reserve potential for achieving further improvement in alert-duty performance. Stressing the significance of the guidelines of the April and July (1985) CPSU Central Committee plenums pertaining to enhancing the role of the human factor in rapidly shifting our country's economy to a path of intensive development, party committee members comprehensively discussed ways and means of increasing the responsibility of aircrews, leading ground specialist personnel, party and Komsomol activists of alert-duty crews for mission performance results. In its resolution the party committee instructed leader-Communists and subunit party organizations to focus greater attention on selection and placement of activists and to ensure that they display a strong personal example in performance of duty and political indoctrination work with personnel.

It is noted that today the majority of alert-duty flight pilots and technicians [crew chiefs] have a strong sense of responsibility toward performance of their duties and display party-minded commitment to and concern with maintaining combat equipment in an immediate scramble readiness and a suitable airman moral-psychological attitude. Among the finest in the regiment is Military Pilot 1st Class Gds Sr Lt V. Lyadetskiy, whose experience and know-how in working in an alert-duty flight have been synthesized by the party committee and disseminated throughout all subunits.

The thought of performing alert duty according to the laws governing the front line fills many party and agitation-propaganda measures with purpose and specific content. We must also mention the enormous emotional, mobilizing influence on young aviation personnel generated by get-togethers with famed combat veteran pilots. The air forces of the Group of Soviet Forces in Germany are carrying on their fame and tradition in a worthy manner. Hero of the Soviet Union Mar Avn S. Rudenko, former commanding general of the 16th Air Army, famed combat ace three times Hero of the Soviet Union Mar Avn I. Kozhedub, and many other veterans pay continuous attention to the doings of military aviation personnel. Fairly recently aviation units and subunits were visited by Hero of the Soviet Union M. Devyatayev, whose name and exploit have become legend.

The priceless combat experience of the war still retains its significance many decades later. Stories by veterans about the courage and military valor of

the winged defenders of the homeland leave an ineradicable impression. And words uttered by persons who fought the hated enemy in the last war ring out with particular passion and emotion. Their appeal not to forget the lessons of the war, to be vigilant and prepared at all times to engage in mortal combat with a clever and powerful adversary carries a charge of great mobilizing force.

Concern to ensure a high degree of spiritual and intellectual alertness and an increased sense of responsibility on the part of aviation personnel for high-quality and effective performance of alert-duty missions is the reason for constant attention on the part of the political department of the air forces of the GSFG as well as political agencies and party organizations of units toward matters pertaining to improving party political work, seeking and practical adoption of everything of a vanguard and instructive nature.

At the present time aviation garrisons are doing a pretty fair job of providing orientation for and breaking in young officers and warrant officers who prior to their present duty assignment have performed job duties not connected with performance of alert duty. Commanders, staffs, and political agencies arrange for appropriate senior-level commanders, expert combat pilots and persons with expert knowledge of the aircraft to speak to them. As a rule party committees and buros assign the best-prepared Communists to give individual assistance to newly-arrived pilots, aviation engineer service, communications and rear services specialist personnel. In the political department headed by Lt Col V. Baskakov, for example, presentation of accountability reports by party members and candidate members is regularly utilized to develop in Communists a strong sense of party responsibility for exemplary performance of alert duty. In the last training year reports on matters pertaining to personal exemplariness in performing assigned tasks and missions were presented in the political department by officers A. Pismenskiy and V. Gurskiy, while a report by party member Ch. Vnuchko was presented in the directorate party organization.

Unit commanders and deputy commanders as well as political section officers skillfully organize and personally conduct indoctrination work during the period of preparation by aviation personnel to stand alert duty. A special log is kept in political agencies to record such activities, to systematize and classify observations and conclusions, while an activist task assignment workbook is maintained in alert-duty flights.

In recent years we have regularly, once during each period of training, held at one of the vanguard units seminars for squadron deputy commanders for political affairs and party buro secretaries, at which we address issues pertaining to organizing effective party political work with alert-duty subunit personnel. The officers reinforce the knowledge they obtain at the seminars in practical demonstration classes. In addition, once every three months, usually during commander training days, the state of party political work during alert duty is analyzed in detail and evaluated in political agencies together with subunit deputy commanders for political affairs, and exchange of experience and know-how as well as discussion of the documents governing mission execution are organized.

Of course political agencies and party organizations do a great deal more to develop in leader-Communists and all aviation personnel readiness and willingness to carry out assigned alert-duty missions. But in a unified aggregate of ideological-theoretical, political indoctrination and organizing activities, such measures exert beneficent influence on the men and their attitude toward performance of their military duty. Convincing confirmation of this is offered by the continuously high results in performing alert-duty missions achieved by Capts A. Ruban, A. Titarenko, and G. Surovtsev, by Sr Lt G. Skoreyev, and many other pre-congress socialist competition right-flankers.

At the April (1985) CPSU Central Committee Plenum, CPSU Central Committee General Secretary Comrade M. S. Gorbachev emphasized that in preparing for the congress, at report-election meetings and in party organizations, it is important to summarize in a Leninist manner what has been accomplished, without phony idealization or empty logomachy, to gather together positive experience and know-how bit by bit, to reveal deficiencies and shortcomings, and to specify ways to improve things. Performance results of the past training year, reports and elections in GSFSG air forces primary party organizations indicate that another step forward has been taken toward improving combat readiness and military personnel expertise.

In addition to achievements, however, one can also see shortcomings and miscues. For example, analysis of the state of party political work during alert duty from the standpoint of present-day party demands, and taking into account the world military-political situation, indicates that this work is not yet being done in all military outfits in full measure, consistently, with high quality and adequate persistence. Some commanders and political workers have not yet freed themselves of a simplified notion about the forms and methods of party political work when on alert duty. For example, the regimental party committee of which Maj G. Danilin is a member has patently lacked due firmness and demandingness in handling certain matters. This was pointed out in a forthright manner to the party committee secretary and members during work by GSFSG air forces political department officers in this unit. The situation in the unit is presently changing for the better.

There is no place and can be no place for unnecessary relaxation of demands and unnecessary situation simplification during alert duty, where the laws governing the front line are in full effect, and in efforts to ensure a continuous high degree of aviation personnel combat readiness. This is demanded by the party, which is accompanying its steps toward peace with strengthening of military preparedness. GSFSG air forces personnel are constantly aware of the paternal concern of the CPSU and the entire Soviet people to ensure that the Armed Forces are adequately provided with equipment and supplies, and they respond to this concern with additional successes in job performance and in meeting socialist pledges adopted in honor of the 27th CPSU Congress.

COPYRIGHT: "Aviatsiya i kosmonavtika", 1986.

3024

CSO: 9144/206

WEAPONS DELIVERY COMPETITION BETWEEN TRANSBAYKAL, FAR EAST MD AIRCREWS

Moscow AVIATSIYA I KOSMONAVTIKA in Russian No 2, Feb 86 (signed to press 3 Jan 86) p 6

[Article, published under the heading "Effectiveness and Efficiency to Competition," by Lt Col V. Paramonov: "There Were No Losers"]

[Text] The draft revised CPSU Program states the importance of further improving and increasing the effectiveness of socialist competition. It notes that it is essential to eradicate excessive attention to form with consequence detriment to content, as well as predictable routine, and to make every effort to support initiative and productive ingenuity by the masses directed toward achieving better end results of labor. All this has a direct relationship to the training of highly-skilled military aviators and improving their professional skills. It is no secret that sometimes tactical air exercises conducted in aviation units and subunits as well as weapons-delivery training sorties are conducted on a simplified scheme, without employing new tactical moves, lacking intense combat with employment of the element of surprise, stealth and swiftness.

At a combat flying competition between the pilots of the air forces of the Transbaykal and Far East military districts, held last year for the first time, an attempt was made to depart from the customary scheme and to give aircrews the opportunity to proceed independently in preparing for a mission, in decision-making and choosing maneuvers for delivering strikes on ground targets. Results indicate that this is a good, useful idea which should be further encouraged.

First the combat pilots took tests in tactics theory, knowledge of their aircraft, and the combat capabilities of missile systems and armament. All-around knowledge was displayed by fighter-bomber flight commander Maj V. Sakin (Transbaykal MD), bomber flight commander Maj A. Kozin (Far East MD) and aircraft commander V. Tarasov (Transbaykal MD), helicopter gunship section commander Capt V. Mirzarasulov (Transbaykal MD) and aircraft commander Capt P. Semkin (Far East MD).

The crews were then to fly weapons delivery sorties. The helicopter crews were the first to go out. A Transbaykal MD helicopter gunship section consisting of crews commanded by Capt V. Mirzarasulov, A. Aspednikov, I. Kutakov, and Maj V. Gushchin was to penetrate "enemy" air defense, reach the range precisely on schedule, on an initial pass to fire antitank missiles at small targets, and in a second pass to deliver a strike with air-launched rockets.

Crews carefully and thoroughly preflighted their helicopters and climbed aboard. On command they fired up their engines, took off and headed toward the range. Maximally exploiting the masking and concealment capabilities of the terrain, the pilots penetrated through the "enemy" air defense zone and reached the range precisely on schedule.

"613, 614 on final target heading!" reported Capt A. Aspednikov to range officer Col B. Timoshenko.

"613, target -- 21-4. 614, target -- 21-5. Cleared to arm weapons," the range officer radioed.

The helicopters executed a zoom and proceeded to descend.

"We are attacking!"

"Cleared to attack," the range officer confirmed.

Weapons officers Sr Lt A. Kalyagin and Lt A. Kopkov peered at their sights. Although they had flown air-to-ground strikes on more than one occasion in the past, nevertheless each strike is unique in its own way. Performing the required weapons system operations, they reported ready to fire the missiles.

"Fire!" the pilots ordered.

The officers and general officers atop the range observation tower watched as the missiles leaped from the launchers almost simultaneously and streaked toward the "aggressor" tanks. Bull's-eye!

The pair of helicopters flown by Capts A. Aspednikov and I. Kutakov also did well on their second strike pass, firing rockets. The combat pilots displayed a high degree of weapons expertise in spite of the weather, which had deteriorated.

The Far East MD helicopter crews also did a skillful job on the range. The best results were produced by the crews of S. Ilinskiy and P. Semkin.

Frontal Aviation bombers then appeared over the range. They were tasked with bombing an "enemy" antiaircraft missile position and with hitting pinpoint ground targets.

The Far East MD aircrews demonstrated excellent group flying precision and a high degree of tactical proficiency. The crews of A. Kozin and Capt V.

Safronov also performed smoothly, flawlessly, and with precision on their second pass, scoring hits on all targets.

Transbaykal MD bomber crews which had recently transitioned over to a new aircraft also achieved success. As Lt Col V. Popov related, the aircrews had prepared for competition on a special training program and had done a great deal of additional work.

We must admit that on the whole Maj V. Mogutnov's flight did well at the range. The crew of Capt V. Tarasov did a particularly fine job. Navigator Capt V. Lekomtsev displayed a high degree of skill in navigation and bombing.

The fighter-bombers wound up the competition. They hit an "enemy" airfield flight line and delivered cannon fire at small ground targets. The Transbaykal MD flight under the command of Maj V. Sakin defended the honor of their squadron of experts at weapons delivery. In the last training year this flight took part in many tactical air exercises, and these combat fliers always performed to the very highest standard.

Operating in difficult conditions, the flight's two-aircraft elements navigated to the range with precision. Receiving clearance from the range officer, the pilots armed their weapons. Diving out of the clouds, they hit the aircraft flight line. They placed their bombs accurately onto the target. Their cannon fire was delivered with equal success.

Their competition rivals -- Lt Col V. Didenko's flight (Far East MD) -- also produced excellent results. The Far Easterners' bombing accuracy was not quite as good, however.

The marks given on knowledge of theory and ordnance delivery were considered in determining winners. Each mission in turn was graded by element: takeoff, holding to route, control and radio communications, air defense penetration, time-schedule accuracy in reaching the target, accuracy of bombing, missile firing, gun and rocket fire, landing approach, and landing. These elements were used to determine an overall grade for each crew and flight by air component.

At the end of the 6-day contest, the helicopter winner was the section commanded by Capt V. Mirzarasulov (Transbaykal MD) and the crew of Capt A. Aspednikov from the air forces of that same district. The best among the bombers was Maj A. Kozin's flight (Far East MD), while first place among aircrews was taken by Capt V. Safronov's crew (Far East MD). Maj V. Sakin's flight (Transbaykal MD) was the fighter-bomber winner. The flight commander himself had the best mark in the competition between pilots of this air component. His flight, which also included Capt V. Morozov, V. Dubrov, and Sr Lt V. Prystavka, was also the overall competition winner.

We asked Honored Military Pilot USSR Lt Gen Avn F. Stepkin to give his opinion of the competition.

"There were no losers in the weapons delivery competition between pilots of the air forces of the Transbaykal and Far East military districts," he stated,

"although the Transbaykalians achieved the best results. The important thing is that all aviators performed with enthusiasm, innovatively, and demonstrated improved tactical and weapons skill and thorough knowledge of their aircraft and weapons. It is also important to maintain the airmen's enthusiasm in the further course of combat training. Engaged in socialist competition in the new training year under the slogan 'We shall implement the decisions of the 27th CPSU Congress, we shall reliably defend the achievements of socialism!' The airmen of these districts are endeavoring to reach new and higher levels of performance in improving their combat skills."

COPYRIGHT: "Aviatsiya i kosmonavtika", 1986.

3024

CSO: 9144/206

AVIATION WORKER TRADE UNION COMMITTEE ACTIVITIES

Moscow AVIATSIYA I KOSMONAVTIKA in Russian No 2, Feb 86 (signed to press 3 Jan 86) pp 8-9

[Article, published under the heading "We Report to the 27th CPSU Congress," by V. Kalosha, Central Committee secretary, Trade Union of Aviation Workers: "Moving Forward, Achieving More"]

[Text] The 27th CPSU Congress is an important event in the life of our party and people.

The final stage of preparations for it in trade union organizations of Air Forces workforces, scientific research organizations and educational institutions is taking place in an atmosphere of businesslike efficiency and intense, productive work effort. Activist, strongly-committed participation by engineers, technicians, teaching faculty, scientists, and specialists in various fields in discussing the draft Basic Directions of Economic and Social Development of the USSR in 1986-1990 and the Period Up to the Year 2000 convincingly confirms that aviation workers, just as all our country's workers, are today imbued with the spirit of positive changes and an endeavor to move forward, refusing to retreat in the face of difficulties and measuring their practical deeds up against the guidelines of the April and October (1985) CPSU Central Committee plenums and other major party program documents.

Under the guidance of political agencies and party organizations, the trade union memberships of Air Forces enterprises and establishments are, together with the command authorities, making a weighty contribution toward increasing the combat readiness of aviation units and training highly-skilled cadres.

Today, when further development of the economy depends in large measure on its intensification and all-out acceleration of scientific and technological advance, there are also increased demands on the quality of performance of the tasks carried out by our workforces. And this has demanded in turn improvement in the mechanism of economic management, production management style and methods, aggressive practical adoption of scientific and technological advances, further strengthening of discipline and order, and observance of an economy regimen.

Carrying out the party's decisions, the Central Committee of the Trade Union of Aviation Workers as well as the trade union committees of Air Forces enterprises and establishments have in the pre-congress period concentrated their efforts on reworking people's consciousness and giving effective aid to command personnel, political agencies and party organizations in resolving production problems. The goal is to overcome still-encountered sluggishness and routinism, passivity and slackness, irresponsibility and wastefulness, affirmation of an innovator approach to the assigned task, further enhancement of the trade unions' role in accomplishing present tasks, and their influence on workers and white-collar employees.

This statement of the question is in conformity with the party's strategy line. In summing up the results of socialist competition to greet the 27th CPSU Congress in a worthy manner, we can state that the work being done has had a positive effect on the affairs of many aviation workforces.

In the course of pre-congress competition, for example, the best results in meeting plan targets and upgraded pledges were achieved by the workers of the exemplary overhaul and repair enterprise headed by officer P. Payusov and the workforces headed by party members I. Rybin, V. Koshovnik, V. Mironov, O. Novoselskiy, and V. Klimenko. The trade union committees headed by Ye. Sobol, A. Masyuk, Ye. Vorobyeva, D. Polonnikov, and I. Khoreva were extremely helpful to command authorities and party organizations in mobilizing personnel to honor the 27th CPSU Congress in a worthy manner.

The experience of the trade union committee where V. Zhukovetskiy serves as secretary is a model of concern for increasing the effectiveness of socialist competition. They drew up detailed recommendations concretizing the provisions of adopted pledges and ensuring precise verification of their execution at all stages of competition. This made it possible to focus each and every employee, each and every brigade, section, shop and the workforce as a whole on further improving production efficiency and work quality. As a result socialist pledges in honor of the 40th anniversary of the Great Victory were met ahead of schedule, by 25 April. By the 50th anniversary of the Stakhanovite movement more than 270 workers and 16 brigades had completed their five-year plan labor productivity growth targets. Nor did the work pace drop toward the finish of the pre-congress competition.

The trade union committee is using all forms of indoctrination and organizing activity, moral and material work incentive to mobilize workers and white-collar employees to speed up scientific and technological advance, aggressively to put into practice new technologies, means of mechanization and automation, and to improve production planning, organization, and management. Savings in the amount of approximately half a million rubles were achieved through this by the end of 1985. The unit's inventors and efficiency innovators contributed 15 percent of this amount to the overall pot.

The fruitful labor and successes of vanguard performers do not go unnoticed. Recently the enterprise workforce was awarded a Certificate of Merit of the Central Committee of the Trade Union of Aviation Workers. This at the same time constituted validation of the trade union committee's performance.

In conformity with the requirements of the CPSU Central Committee and USSR Council of Ministers decree entitled "On Wide Dissemination of the New Methods of Economic Management and Intensification of Their Influence on Speeding Up Scientific and Technological Advance" and the provisions of the draft Basic Directions of Economic and Social Development of the USSR in 1986-1990 and the Period Up to the Year 2000, the trade union committees of Air Forces enterprises are devoting close attention to the adoption of economic accountability and other progressive forms of organization of labor.

At the enterprise headed by officer V. Gribovskiy, at which party member A. Sokolenko serves as trade union committee chairman, one out of every three brigades is operating according to the principles of economic accountability. The experience they have amassed indicates that brigade economic accountability greatly promotes maximum utilization of the advantages of collective forms of organization of labor, increases labor productivity, helps achieve economies in resources and supplies, and ensures personal commitment by each and every brigade member to achieve a high end result.

For example, collective and personal socialist pledges in honor of the 27th CPSU Congress by V. Yaremchuk's brigade (trade union group organizer V. Parnis) call for completing the production program by the 26th of each month through mobilization of internal reserve potential. And for many months now they have been solidly holding to this schedule. In two years of working in the new manner, the workforce has saved more than 1,000 rubles worth of materials.

The enterprise trade union took active part and gave practical assistance to the brigade council in drawing up criteria for changing the coefficient of labor participation, with the aim of objectively appraising the contribution of each specialist in meeting plan targets. A great deal is also being done in the area of study and extensive dissemination of the experience of this and other cost-accountable production subdivisions and to improve the forms of the brigade contract. In the aircraft equipment repair shop, for example, two consolidated combined brigades, headed by A. Lapinin and P. Novoselskiy, have been formed to replace the seven previous brigades. Here too trade union activists endeavor by word and deed to help the brigade leaders more rapidly surmount the natural difficulties of reorganization and obtain maximum return on effort.

Territorial trade union committees, together with the command authorities and political agencies, give considerable assistance to workforces in accomplishing assigned tasks and meeting pregress socialist pledges. Examples include the Carpathian, headed by USSR State Prize recipient M. Mikhnovskiy, formerly a brigade leader at an Air Forces repair and overhaul enterprise, the Belorussian, headed by V. Balbakov, and the Central, headed by A. Seltsov.

Deficiencies were noted in some collectives, however. The Volga Territorial Committee, shared by L. Kulev, was slow about reorganizing its work in conformity with the demands of the April and October (1985) CPSU Central Committee plenums. Not all trade union organizations were aggressively influencing pregress socialist competition and were far from fully

utilizing its potential for mobilizing workers and white-collar employees to accomplish further improvement in quality of repair and overhaul of aircraft equipment, as well as accomplishment of other production tasks. Similar passivity was noted, for example, in the activities of the trade union committee at the enterprise headed by M. Salikov. Trade union activists frequently ignored deficiencies in organizing and totaling up results of socialist competition, failed to provide publicity to competition, did not thoroughly analyze reasons for failure to fulfill plans and adopted pledges, and were not taking measures to boost average and lagging performers.

The Central Committee of the Trade Union of Aviation Workers ordered the chairman of the Volga Territorial Committee radically to alter his work style, to take specific measures, and to render effective assistance to enterprise trade union committees in correcting deficiencies, specifying a timetable and persons responsible for correcting the problems.

Measures were taken and had effect. The trade union committee of the indicated enterprise, for example, began more closely examining the course of socialist competition and campaigning for the adoption of advanced know-how and for stepping up the mentorship movement. And things changed for the better for this workforce.

During the early years of Soviet rule V. I. Lenin noted: "Communist organization of societal labor, the first step toward which is socialism, is maintained and will increasingly be maintained on a foundation of free and conscious discipline on the part of the workers themselves...." Time has convincingly confirmed and continues to confirm the unfading truth of Lenin's words.

The newness and complexity of the tasks of the present stage of improvement of developed socialism is imposing increasingly tougher demands on discipline -- both labor and technological discipline, and this is understandable. On the one hand acceleration of scientific and technological advance and extensive mechanization and automation of production are themselves creating the objective preconditions for precise order and organization. On the other hand rapid enhancement of the role of each worker on the workforce, that is, the human factor, is enhancing the significance of such qualities as composure, responsibility for the assigned task, and a feeling of duty to society.

The draft new revised CPSU Program states that the trade unions are called upon to carry out their principal functions in a consistent manner: to make every effort to foster growth of the national wealth, to improve people's working conditions, living conditions, rest and recreation, to defend and protect the rights and interests of the workers, constantly to engage in communist indoctrination of the masses, to involve them in management of production and societal affairs, and to strengthen conscious labor discipline.

The Carpathian, Odessa, Belorussian, Transcaucasus, and Central territorial trade union committees have worked the most persistently and purposefully to strengthen discipline and order in the pre-congress period. In these territories up to half and more of the primary trade union organizations and

80-90 percent of production brigades are working without violations of labor discipline.

What is even more important, improvement of the brigade form of organization of labor and labor incentive is exerting appreciable influence in these collectives on strengthening discipline, reducing the rate of labor turnover, and intensifying the campaign against drunkenness and alcoholism. For example, in the cost-accountable brigades at the enterprise at which V. Zhukovetskiy serves as trade union committee chairman, work time losses have been cut in half, while cases of arriving at work late and leaving early as well as incidents of violation of public order have decreased by a factor of five.

Practical experience indicates that it is necessary more fully to utilize the experience of front-runners and to increase efforts to strengthen discipline and organization.

Recently economic and trade union agencies have done a great deal to improve working conditions and industrial safety. Some organizations, however, still are making little use of collective contracts, agreements and comprehensive plans for improving working conditions and industrial safety, as well as health improvement measures. Renovation of shops, efforts to reduce shop noise and dust level, as well as to automate and mechanize sections with unhealthy working conditions are proceeding slowly at some plants. We cannot accept this state of affairs.

The comprehensive plans drawn up for the period of the 12th Five-Year Plan prescribe extensive measures to accomplish further improvement of working conditions and industrial safety, level of sophistication of production and quality of employee services, and to achieve a decrease in the rate of injury on the job, occupational and general incidence of disease. This by no means signifies, however, that we can relax right now at this time, postponing this important and necessary work to a later date. Utilizing the possibilities and rights granted by the USSR Law on Labor Collectives [workforces], we must proceed without delay, more boldly placing emphasis on development of volunteer participation in labor protection activities. Monitoring of working conditions, observance of industrial safety requirements and standards should become a genuinely mass, universal and effective undertaking, while persons guilty of violation of production and technological discipline should be held strictly accountable.

In short, we are addressing a substantial agenda. Just as all Soviet citizens, the workers and white-collar employees of Air Forces enterprises and establishments are striving to strengthen with their labor the homeland's economic and defense might and to devote all their energies and resources to implementing the party's plan.

COPYRIGHT: "Aviatsiya i kosmonavtika", 1986.

3024

CSO: 9144/206

FORWARD AIR CONTROLLER WOUNDED IN AFGHANISTAN

Moscow AVIATSIYA I KOSMONAVTIKA in Russian No 2, Feb 86 (signed to press 3 Jan 86) pp 16-17

[Article, published under the heading "They Were Decorated by the Homeland," by Candidate of Philosophical Sciences Lt Col N. Stolyarov: "Faithfulness to Duty"]

[Text] A military scientific conference was being held at the Air Force Academy imeni Yu. A. Gagarin. The presiding officer announced: "First-year student Maj Valeriy Anatolyevich Burkov will now present a paper on the topic 'Conflicts and Contradictions Within the Aviation Subunit Command and Control System and Ways to Resolve Them.'"

The auditorium grew still. A well-built young officer strode confidently toward the podium. There was a slight tenseness to his stride, it is true. A person who did not know him might think that it was caused by nervousness....

...Akeksandra Timofeyevna could sense it with her maternal heart: her son had made up his mind. And although she was well aware that she could do nothing to change it, nevertheless she looked at him hopefully: might he not change his mind? Replying to his mother's mute question, Valeriy stated quietly but firmly: "I have to, mom."

"I know, son. I have just one request: take care of yourself...."

The previous day he had submitted a request to his commanding officer: "I would like to request a detached-duty assignment.... I would like to carry out my internationalist duty and be worthy of my father, who was killed in the Democratic Republic of Afghanistan."

The gray-haired colonel laid the written request aside and, gazing at the young officer, proceeded to ponder the matter. He had been assigned to the unit quite recently, after being permanently grounded from flight duty, but he had already proven to be a promising tactical control officer. It was no easy matter to master a new job. Valeriy naturally wanted to fly himself, but he had to control missions being flown by others. The sad fact of the matter is that medicine places stringent demands on the health of flight personnel. The colonel knew through personal experience how difficult it is at first to feel

shunted aside from one's favorite activity. Burkov also at first had difficulty becoming comfortable with his new situation. Since childhood he had been drawn by the romance of the skies. He had graduated from the Chelyabinsk Higher Military Aviation School for Navigators. He was one of the few members of his graduating class to receive the military navigator 3rd class rating and was assigned to flight duty as member of a bomber crew.

Valeriy's father, a military pilot, had instilled in Valeriy a love of aviation and of the profession of defender of the homeland. In the Burkov family the children were taught not by moral admonitions but by the strength of the example of their parents. The children never felt excessive strictness, despotic demandingness, or excessive leniency and all-forgiveness. In this family spiritual richness was prized above all things. Joy of living, optimism, and diligence -- the family's constant companions -- always helped them overcome burdens and privations, which are almost inevitable in the life of a military man and his family. They also helped Valeriy come to grips with himself and take a worthy place among his fellow aviators.

Lieutenant Burkov was respected by the men in his outfit. They liked him for his cheerful disposition, for the fact that he sang and played a great many musical instruments with enthusiasm, for his kindness and the fact that he was true to his word, for his sincerity, his unpretentiousness and modesty, and for the fact that he had the ability to make bold decisions and assume responsibility. But what was it that was keeping the colonel from immediately signing the young officer's request?

"Comrade senior lieutenant," he addressed Burkov in a markedly official tone, "I must warn you that the available specialist detached-duty slot is a grade below the one you presently hold."

"That is not the important thing. I am willing to take any position."

"All right, Valeriy Anatolyevich. But since this is your second request, would you please explain what is motivating you? I hope it is not a desire for vengeance."

"No, comrade colonel," Burkov calmly replied. "When my father was alive he taught me that life is not a stage play. An upright person cannot remain indifferent when injustice is taking place.... In a neighboring country counterrevolutionaries are hindering people from building a new life. My father's helicopter was crippled by the dushman [rebels, bandits] when he was on his way to assist the local inhabitants. He was not a passive bystander! I too want to be there."

Falling silent a moment, he added in a firm voice: "I cannot do otherwise. It is my duty."

Duty. How often we hear and speak this short but expressive word. How many people it has set into motion, raising their manner of thought and action to the level of heroism! Obligation is a synonym for duty. Entering into various linkages and relationships with society, the state, and individuals, a

person assumes certain obligations to them. Intelligently grasped and voluntarily perceived, they are embodied in duty. Duty is a powerful motivation to socially significant action, a source of daring, a high degree of conscientiousness, a regulator of man's conduct in society.

Defense of the interests of the homeland is a matter of honor and conscience to the Soviet citizen. This moral demand of society is formally articulated in the USSR Constitution and is viewed as the sacred duty of each citizen. And patriotism is the highest type of societal duty. Love of the homeland -- this beautiful, lofty feeling -- distinguishes genuinely courageous, spiritually rich individuals.

But there is also an inverse relationship. Taras Shevchenko wrote: "Those who have no love for their native land are wretched cripples of soul and heart."

Genuine patriotism is inseparable from internationalism. As he builds a better future for himself, the genuine internationalist cannot passively watch the sufferings of other peoples. The imperialists unleashed an undeclared war against the Democratic Republic of Afghanistan. The people proceeded to fight external and domestic counterrevolution. The Burkovs, father and son, aware by mind and heart of the need to assist their brother people, did not remain apart from this struggle.

...A dushman band had woven a spider's web lair in a remote mountain gorge. Considering themselves to be absolute masters of their domain, the bandits robbed and killed the defenseless inhabitants of kishlaks [villages], burned dwellings, and threatened reprisal against all persons who supported progressive, democratic undertakings. The small Afghan Army garrison and tsarandoy (people's militia) in that rugged, inaccessible area lacked the resources to cope with the Basmachi [counterrevolutionary bands], who were well armed and supplied from abroad. The authorities appealed for assistance to the Soviet military command, which dispatched a rifle subunit into the area. Forward air controller Senior Lieutenant Burkov accompanied the ground troops.

The subunit advanced comparatively rapidly, observing particular caution. Combat engineers moved out ahead. The dushman had skillfully concealed landmines of U.S., Italian, and West German manufacture on roadways and road shoulders, at what would seem to be the most unlikely spots.

After crossing mountains, they approached an area of lush vegetation -- half-wild gardens and orchards, interspersed with the walls of old caravansaries, stretched along the road. The unit halted by a derelict aryk [irrigation ditch]. Seating himself on a rock, Burkov examined the surrounding area with interest -- this was his first field campaign. Everything here seemed strange and unusual.

Suddenly the trees proceeded to shed small twigs and branches, and the sound of shots could be heard. "They're shooting for some reason," Valeriy said to himself, without giving any thought to the meaning of what was occurring.

Somebody set off at a run, stumbled, and fell.... Suddenly a powerful hand pulled him into the ditch, which was half full of water.

"Dushman! An ambush, comrade senior lieutenant!" shouted a mustached sergeant, selecting a convenient firing position.

Alongside the sergeant several soldiers were squeezing off short bursts with their assault rifles in an outwardly calm and businesslike fashion. Burkov was struck by this calmness, which literally breathed strength and self-confidence. Subsequently he became convinced time and again that a great deal can be learned from veteran soldiers, including moral fortitude.

Bullets were whistling overhead with increasing frequency. A mortar round crumped somewhere in the vicinity. The bursts were moving closer. The fighting was growing in intensity. The men displayed smooth teamwork. One felt that they were being controlled by an experienced hand. Terse commands could be heard through the din of the fighting.

"But what should I do?" Burkov said to himself. Suddenly he heard the battalion commander's voice: "Air, get over here!"

Valeriy grabbed his assault rifle and field radio and headed at a run straight toward a small bridge across the aryk, from where the order had come.

"Who the hell runs like that under fire?!" the battalion commander shouted when Burkov flopped down alongside him. "This is not a track meet. Never mind, you'll learn to run zigzag. But for the moment look over there. The old fort on the slope. Dushman mortars are positioned there. We're sitting ducks. Call in air support!"

Burkov quickly tuned to the proper frequency on his transceiver and established radio contact with the air control center.

"Get a pair to grid square 7 urgent!"

"This is Saturn, roger. Coming right up...." he heard through the static over his headset.

The FAC's interest was no longer drawn by the natural beauty of the Afghan landscape. He had to select a location from which to direct the aircraft. Spotting a suitable high-ground site, Burkov decided to make his way there.

"Go ahead, but be careful. Don't expose yourself to fire -- that is not courage. Suppress those mortars for us, and we will do the rest. Go ahead! We'll cover you." The battalion commander slapped Valeriy on the back.

The selected site was a good one. It offered a clear view both of the fort and the approaches to it. Soon a pair of helicopters appeared from behind the ridge.

"Two four zero, this is 'Pilot.' Target three zero degrees right, range 2 kilometers. An old fort."

"Roger. What is your location?"

"Right next to it. 60 meters."

"Couldn't you have gotten any closer?" the leader asked, with a note of dry humor. "Hold tight! We'll try not to hit you."

Powerful explosions shook the ground. Valeriy was wreathed in dust and smoke. The adobe fort had been reduced to rubble.

"Good job!"

"Is it still standing? How about another pass?"

"Why don't you, just for good measure."

Now lacking fire support, the dushman ceased fire and proceeded to withdraw. The riflemen continued moving toward the bandits' base camp.

"Congratulations, Valeriy, on your baptism of fire. You passed the test pretty well. Frankly, I had my doubts at first. Now I would be willing to go into any operation with you." The battalion commander spoke cheerfully, clapping Burkov on the shoulder. "Tell me the truth, were you scared?"

"At first I didn't even realize that this was the real thing. But as I was heading for the high ground I was afraid I would not reach it and let you down. Subsequently, when the helicopters struck close to my location, I got scared."

"Doesn't mean a thing. Everybody experiences fear," the battalion commander replied. "Suppressing it is real courage. Where does it come from? I believe from confidence in the righteousness of our cause."

Burkov subsequently took part in many operations conducted by the Afghan Army to wipe out bands of rebels. On each occasion he gained greater confidence, ability and skills in controlling helicopter crews from the ground. He became convinced by experience that success in air support depends entirely on intelligent organization and careful honing of joint actions by air and ground subunits, as well as efficiency, firmness, and flexibility of control. Mistakes cannot be tolerated in these activities. Real combat is not an exercise in which the adversary is simulated. It is the real thing. The dushman are vicious, cunning, and well armed. And any miscalculation in control or lack of smoothness and coordination leads to losses and casualties. One cannot afford to be indifferent, casual, performing one's job in a perfunctory manner.

The laws of war, just as the rules of flying, are stern. They are written in blood, and nobody is entitled to violate them. Not only the airmen but also those commanders whose actions the aircraft are supporting should be thoroughly familiar with these laws. Burkov himself had thoroughly studied ground subunit tactics and capabilities as well as the specific features of

ground subunit mountain operations, and he skillfully utilized his accumulated experience and know-how in a practical manner. This officer was awarded the Order of the Red Banner for courage and heroism displayed while rendering internationalist assistance to the people of the DRA, and he received an early promotion to the rank of major.

...A report by the Air Forces personnel chief to the commander in chief of the Air Forces read as follows: "On 23 April 1984 Maj V. A. Burkov was gravely wounded while performing a combat mission. Both feet were blown off by a landmine, and he took fragments in the right shoulder, causing damage to the brachial artery and contusive injury to the radial and median nerves....

"Following convalescence at a military hospital, at the personal request of Maj V. A. Burkov and on petition by the Air Forces Personnel Directorate, he was certified fit for peacetime non-line service.... He is able to walk with prostheses without a cane.

"On 24 April 1985 Major Burkov requested that he be sent to the Democratic Republic of Afghanistan, stating his wish to utilize his acquired working experience and know-how to improve air control. He attached specific, sound recommendations to his request. If a duty assignment in the DRA is out of the question, he requests that he be assigned to the air forces of the Turkestan Military District.

"The Air Forces Personnel Directorate proposes that Maj V. A. Burkov be assigned to a staff position in the air forces of the Red-Banner Turkestan Military District, and that subsequently he be permitted to enroll in the command faculty at the Air Forces Academy imeni Yu. A. Gagarin."

The commander in chief carefully studied the request and Burkov's service record. The marshal of aviation was moved by the sparing words. He recalled his war-scorched youth, the courage and self-sacrifice of his fighting comrades. He himself had looked death in the face time and again. They had been engaged in a savage fight with fascism for the honor and independence of the Soviet people. And now, many years later, he once again had encountered the same purposefulness in a Soviet officer who had absorbed all the finest elements from the experience of the people who had gone through the flames of the Great Patriotic War. What do the combat veterans of the war and today's military aviators have in common? Faithfulness to duty is perhaps the most important common element. A people which has developed such sons, genuine patriots and internationalists, merits admiration!

The commander in chief of the Air Forces approved the recommendation that Maj V. A. Burkov be enrolled at the Air Forces Academy imeni Yu. A. Gagarin.

COPYRIGHT: "Aviatsiya i kosmonavtika", 1986.

3024

CSO: 9144/206

NEW-GENERATION AIRCRAFT BRING HIGHER G FORCES

Moscow AVIATSIYA I KOSMONAVTIKA in Russian No 2, Feb 86 (signed to press 3 Jan 86) p 28

[Article, published under the heading "Constant Attention to Flight Safety," by Doctor of Medical Sciences Professor Col Med Serv G. Glod and Candidate of Medical Sciences Lt Col Med Serv M. Khomenko: "At the Upper Limit of G Forces"]

[Text] Development of highly-maneuverable aircraft required solving new problems in the field of aviation medicine. Aircraft of this type are capable of maneuvering with high ($n-y=9-10$) and, what is particularly important, sustained (tens of seconds) G forces. In view of this fact, specialists in aviation medicine are taking a new approach to assessing them and are taking into account their fundamental difference from those acting on a pilot in the process of operating aircraft developed in past years. This applies both to the resistance of the pilot's organism to their effect and to medical support of flight safety.

Experience in operating such aircraft has shown that high G forces of considerable duration can not only diminish a pilot's work efficiency but in some cases can also lead to a brief loss of working efficiency.

Techniques which counter the effect of G forces are a highly effective means of protecting against them. In sufficiently well trained pilots they increase resistance by 3.6 Gs on the average. Good effect can be obtained by regular practice sessions in the air or on the centrifuge. According to our observations, in certain individuals resistance to G forces has increased by 2.5-3.0, which has enabled them to endure $p-y=9$ for a duration of 45-60 seconds by wearing an anti-G suit. This indicates that the human body contains considerable potential reserve.

Increasing human tolerance to accelerative forces involves increasing the effectiveness of G-force reducing techniques. The fact is that in a relaxed state tolerance in trainee personnel did not change substantially. This attests to the advisability of specialized pilot training and indicates the need for regular flights to practice maneuvers. The effectiveness of protective G tolerance techniques is determined by individual reserve tolerance, which a pilot can utilize in emergency situations, which is of

exceptional importance for increasing his combat efficiency and flight safety.

Protective tolerance-increasing muscular and breathing techniques are complex-coordinated motor processes against the background of a pilot's active work operations. The most widespread technique is that of tensing the muscles of the legs, abdominal pressure, arms and shoulder girdle. Since G forces in flight are not constant, muscular tension must also be varied.

The protective effect depends on how precisely the pilot "follows" change in G forces with muscular tension. Experience in working with flight personnel indicates that in addition to this it is essential, as accelerative forces grow, uniformly to increase foot pressure on the pedals and to maintain that pressure during the entire maneuver. Experiments have shown that anti-G techniques must be performed quickly and vigorously, anticipating the effect of a positive G force, figuring its anticipated magnitude and rate of increase. With anticipation, muscular exertion (with the same protective effect) is smaller by a factor of approximately 1.5, while with greater accelerative forces it is very difficult and sometimes impossible to "catch up" to them with muscular tension.

One of the specific features of flying new-generation aircraft consists in the fact that the generation of high G forces (7 G and more) is not accompanied by the shaking typical of earlier-model aircraft. This can dull a pilot's alertness during intensive maneuver and can affect flight safety.

A pilot's ability to breathe correctly is also of considerable importance. In the past, since high G forces were of brief duration (3-4 seconds), as a rule a pilot held his breath during their effect. A pilot should breathe during sustained positive Gs. The fact is that holding one's breath can lead to serious worsening of a pilot's subjective physical well-being, due to oxygen starvation of the brain. At such moments the pilot should breathe in and out with the chest, while maintaining tension on the abdominal muscles.

These techniques are performed as follows. After breathing in very rapidly (less than a second), the air should be forced out through a narrowed glottis (to produce resistance to exhalation). Breathing out should take not less than 2 and not more than 3 seconds. These techniques should be performed against the background of maximum muscular tension and should be employed with G forces in excess of 6-7, since other methods (anti-G suit, muscular tension) are inadequate.

It is extremely difficult to hold the head inclined forward during the effect of high and sustained positive G forces, and therefore it is recommended that the pilot set the neck and shoulder girdle, as if drawing his head into his shoulders. This decreases the distance between the heart and brain. Head movements are performed smoothly. It is desirable to press the head against the headrest. In pauses between G forces one should relax the neck muscles by tilting and turning the head, which decreases the probability of occurrence of pain sensations in the neck area. In connection with this, in the process of training for flights of this type, it is recommended that one employ special physical exercises to develop the strength and static endurance of the leg,

abdominal, neck and back muscles. Pilot training sessions with dynamic physical work loads, such as long-distance running, over a period of 3 months failed substantially to increase tolerance to accelerative forces. Training sessions with static loads, however, increased accelerative-force tolerance time by 40 percent.

The protective effect of an anti-G suit depends to a considerable degree on proper utilization. Unpleasant sensations indicate an improper fit. Some benefit is obtained by practicing for the purpose of developing skills in proper breathing and muscular tension when pressure is created in the bladders of an anti-G suit.

Spins on a centrifuge are highly effective. Such sessions make it possible within two or three work days to acquaint pilots with the specific features of the effect of high and sustained accelerative forces on the organism and with safety procedures. A pilot practices on the centrifuge methods of performing protective muscular and breathing anti-G techniques, body maneuvers and breathing. Trainees also learn to monitor their own condition. In the opinion of pilots who have trained on the centrifuge, it increases moral-psychological preparedness and enables one to learn one's capabilities in maneuver-rich flight.

Thus the introduction of a new generation of highly-maneuverable aircraft has substantially increased demands on human tolerance to the accelerative forces of flight. This requires a qualitatively new approach to pilot training.

COPYRIGHT: "Aviatsiya i kosmonavtika", 1986.

3024

CSO: 9144/206

Mi-8 COPILOT DOES COMBAT TOUR IN AFGHANISTAN

Moscow AVIATSIYA I KOSMONAVTIKA in Russian No 2, Feb 86 (signed to press 3 Jan 86) p 29

[Article, published under the heading "They Were Decorated by the Homeland," by Lt (Res) G. Korzh, head of the military-patriotic indoctrination department of the republic newspaper KOMSOMOLSKOYE ZNAMYA: "Drawing Fire"]

[Text] Fog hung over the airfield. This meant that the cheerful air flag would not be raised and that no green flares would be fired into the heavens, announcing commencement of flight operations....

Sr Lt V. Kovrigin, just as any other pilot who loves his job, was unhappy at the news that flight operations were being postponed due to the weather. Now they would have to go the alternate schedule and hold classroom training activities. But those were the breaks, as dictated by the weather.

Kovrigin is a young man. Looking at this officer, who wears three gold stars on his shoulderboards, it is hard to believe that this is a veteran combat pilot who has seen duty in Afghanistan and has twice been awarded the Order of the Red Star....

Everybody is forced during one's life to plot a course between "I want" and "I must." A person is revealed as an individual in the correlation between these concepts. At the beginning of his career Kovrygin enjoyed quite a bit of luck. The personal -- he wanted to fly -- and the public -- do that which is necessary -- defend the homeland and world peace -- felicitously coincided in his dream.

Thus he had no doubts about his future. Evidently he would suffer greater hardship not becoming a pilot. There was a DOSAAF airfield not far from his home. On flying days a measured roaring of engines would come from the field, drowning out the noise of the street and the tooting of the switch engines at the freight yard. Almost all the young boys from the two five-story apartment buildings adjoining the airfield became pilots.

But the road to the sky was not an easy one. Vitaliy worked as an electrician at a trolley bus car barn and was able to devote only his evenings to aviation. He was constantly on the run. Plainly a flying club is not an armed services

school. But discipline was strongly emphasized. They would dismiss you for missing classes. Therefore he had to give up a great deal of other activities.

Kovrigin's instructor was Valeriy Tobolnov, a person who definitely possessed the gift of teaching ability. And, the main thing, he loved what he was doing. Even on days off he could not keep away from the airfield, dropping over to be with and talk with the student pilots. At that time Kovrigin did not stand out from the others, but he was one of the first in the group to actually fly.

Later he submitted a request to be accepted to military service. This was a serious step but, once having made his choice, Vitaliy never regretted it. Carrying passengers or spraying fertilizer is of course an important job. But a real job as far as he was concerned could only be in military aviation. For example, he delivered a heliborne assault force at a recent tactical air exercise. And this gave him not only the opportunity to see what the Mi-8 was capable of but also once again to test himself.

The exercise was gathering momentum. The crew of the helicopter on which Kovrigin flew as copilot-navigator was to deliver members of an assault force from the sea. They loaded combat engineers on board, whose job was to clear lanes in "enemy" minefields to open up a path for the assault troopers.

They took off at noon. Kovrigin had never before flown at sea. They would be over the water for about 3 hours. Flying was difficult: gale winds were blowing, and the cloud bases were almost hugging the wave crests. They were practically flying blind. If prior to this day he had been told that one could fly in such conditions, he perhaps would have been disbelieving. But they were in fact flying, and making progress.

The mission was successful. The exercise director commended the helicopter crews. But of course they were not working for the sake of praise. "Since you are a military pilot, at times you must take upon yourself somewhat more than the manual prescribes," Senior Lieutenant Kovrigin concluded at the time.

That is the kind of a job it is. During his time in the service he has on numerous occasions received convincing evidence of the correctness of this statement. Wherever things are difficult, wherever the situation is complicated, the Soviet military airman, a patriot and internationalist, acts with boldness and determination, endeavoring to assume the entire burden and to assist his comrade.

"That is the way things are in our profession," says Kovrigin. You cannot shove off your job onto somebody else. You have to accept responsibility. If you do not do it, your friend must."

Airmen perform difficult missions in carrying out their internationalist duty as members of the limited Soviet forces in the DRA. What good is the mere ability to land a helicopter when the ground is obscured by clouds of dust thrown up by the rotor wash? It takes some getting used to. Many people do not begin to understand, until they spend some time in Afghanistan, what an

outstanding machine the helicopter is, with which pilots work wonders on mountain terrain.

For example, the commander of Kovrigin's helicopter section, Aleksandr Sapega, is a genuine air ace. He would fly at night at weather minimums, and he would pick up people at the bottom of deep gorges. Time and again he had helped Afghan troops fight off dushman [rebel, bandit] attacks. The helicopter pilots devised their own tactics, effective maneuvers, and techniques of evading machinegun fire. Sapega performed these maneuvers with a particular degree of skill. He made very skillful use of the topography, performed beautifully, innovatively, and added something new on each occasion.

Kovrigin learned a great deal from him. Military service in the DRA proved to be truly a man's work, where there was both risk and a sense of danger.

"No, it was not fear," says Kovrigin. "Fear is when a person cannot carry out a mission, when he is as if paralyzed. It is something different -- a feeling of danger and the highest sense of responsibility."

Kovrigin analyzed his feelings at a later time. When he was in Afghanistan he thought only about how better to carry out the assigned mission. This was also the case when they were evacuating the families of Afghan activists. They had to make long flights, across mountain passes, carrying a maximum payload. And the people at the airfield could not believe their own eyes when 20 and sometimes more than 20 passengers -- women, children, elderly persons -- would pile out of a helicopter. They carried everybody out. Nor was he thinking about danger when dushman brought heavy machinegun fire on them up in the mountains. The helicopter flown by the element leader, Captain Gunichev, was crippled: the main rotor was damaged and the tail-rotor reduction gear took a round. The helicopter was unable to maneuver. And the pilot of Kovrigin's helicopter, Capt Igor Panga, proceeded to fly to the aid of his comrades. Drawing attention away from the crippled leader, they drew fire to themselves, and when the enemy gave away his position (an additional concealed weapon position was located nearby), they destroyed him with devastating fire. Vitaliy Kovrigin won his first decoration that day.

He received his second decoration for assisting Afghan troops. They were heavily engaged in the mountains with a dushman band. A two-ship element which included Sapega's aircrew delivered a force of Afghan assault troops. A portion of the band succeeded in breaking contact. The Soviet helicopter crews spotted it and, when the bandits proceeded to fire at the helicopters, responded with salvos of rockets....

The airmen had a lot of work to do in the skies over Afghanistan. So much that now and then there was even no time to think about home. Later, back home in the Soviet Union, when Vitaliy was told about how his son Roman had been greeted by Santa Claus in their new apartment, by a Christmas tree sent by the unit command authorities, he suddenly got a lump in his throat. A tiny detail, but it says a great deal. A pilot lives not by flying alone.

...And today, because of the fog, there will be no flying. Kovrigin and the

other airmen undergo training in the classroom. His whole career still lies ahead of him; a great deal remains for him to accomplish. But he has already firmly learned the main truth and has proven by concrete deeds that, when necessary, the Soviet soldier-internationalist will expose himself to fire.

COPYRIGHT: "Aviatsiya i kosmonavtika", 1986.

3024

CSO: 9144/206

AIRCRAFT DESIGNER ANTONOV'S CAREER THUMBNAIL-SKETCHED

Moscow AVIATSIYA I KOSMONAVTIKA in Russian No 2, Feb 86 (signed to press 3 Jan 86) pp 32-33

[Article, published under the heading "Soviet Aircraft Designers," by Engr A. Samoshkin: "From Glider to Airplane"]

[Text] Readers write the editors requesting that we relate the career of Oleg Konstantinovich Antonov, a gifted Soviet aircraft designer who has designed many transport aircraft which have been widely employed in various branches and sectors of the economy as well as in our glorious Air Forces.

Meeting our readers' request, we offer the following article about O. K. Antonov.

The name of chief designer Oleg Konstantinovich Antonov is well known not only in this country but abroad as well. He has designed a large family of sailplanes and hang gliders, crop dusters and passenger aircraft for short-haul local service, as well as military transport aircraft. They boast excellent aerodynamics, an enviable payload capacity and reliability. All the aircraft he has designed have become dependable, long-lived workhorses.

What is the secret of his success? It lies first and foremost in the style of expression of Oleg Konstantinovich's designer talent, in his extremely hardworking nature and his great sense of responsibility to the country for the assigned task. The chief designer worked selflessly, to the utmost of his abilities. One could always sense in his activities the pulsebeat of creativity and the search for new and promising design solutions based on many long years of experience. He had the ability to find the reasonable and rational path among the many conflicting requirements of aerodynamics, strength, improved technology of aircraft manufacture, operation, and repair.

This inspirational process of modern aircraft design also became the work style of the entire team which Antonov headed for almost 40 years.

In his youth Oleg Konstantinovich designed and built the Golub sailplane together with fellow students at the Saratov Industrial Technical School, and

subsequently at Koktebel had experienced a joyous feeling as he watched his beloved offspring in flight.

His first attempt to take off into the sky and experience the fascination of soaring flight was on a sailplane of his own design, the OKA-2. This enabled the young student to become a sailplane designing enthusiast and to determine his entire future career.

After the OKA-2, Oleg Konstantinovich continued designing simple, inexpensive sailplanes in the Leningrad Flying Club, after which he took over as head of a design office at a sailplane factory in Moscow. In the prewar years Soviet sailplane pilots established a great many records flying his craft. Tens of thousands of young people in the Soviet Union mastered this difficult sport, which was of inestimable assistance to our Air Forces during the grim years of the Great Patriotic War.

Several outstanding sailplanes were designed in the postwar years under Antonov's direction, including the A-9, A-10, A-11, A-13, and A-15, on which distance and speed records were set. Flight experience with these craft helped the future chief designer develop a thoroughly professional intuition in determining the aerodynamic shapes of modern aircraft. Oleg Konstantinovich remained a lifelong enthusiast in the design of ultralight aircraft, and in recent years supported and organized enthusiasts in the area of hang glider design, in spite of the fact that he was extremely busy working on producing modern turbojet transport aircraft.

Way back before the war Oleg Konstantinovich designed an aircraft powered by an ASh-62 IR motor designed by A. Shvetsov. But he was unable to complete this project until after the tumultuous war years, when a young design office established in Novosibirsk received an urgent assignment -- to build a crop-duster aircraft. And the designer successfully accomplished this difficult task: the An-2 took off on its maiden flight on 31 August 1947.

This aircraft contributed a brilliant page to the history of Soviet and world aviation. Oleg Konstantinovich proved by his creative labor that a biplane configuration had not become obsolete for an agricultural aircraft, and the ship's excellent performance characteristics confirmed its high degree of reliability. Soviet industry has built several thousand An-2 aircraft; they are still in regular production, which is without precedent in the history of aviation. The aviation "old-timer" An-2 does 97 percent of the aerial application work in the Soviet economy.

With the appearance of a new turboprop engine, the chief designer advanced the idea of upgrading this aircraft. A new powerplant, a cockpit air-conditioning system, an agricultural chemical payload boosted by 550 kg, and 60 percent greater productivity -- these were the principal distinctive features of the new An-3 aircraft, designed to service kolkhoz and sovkhos fields. This is one of the dialectic spirals in Oleg Konstantinovich's design activities.

To the surprise of Antonov himself, his first agricultural aircraft also became his first passenger plane, for people needed to fly to remote communities, where not only were there no airports but even decent airstrips.

The An-2, into which passenger seats were bolted, proceeded to perform this job. For a long period of time it was hauling tens of millions of passengers each year.

Well aware that a passenger aircraft for local, short-haul service should be highly reliable and comfortable, Oleg Konstantinovich inspired his engineering team to design the An-14 cargo-passenger aircraft, powered by two AI-14 piston engines.

New turboprop engines were developed after this aircraft entered service, and the design office team developed the An-28 aircraft. It would replace the An-2 in local, short-haul service and would provide a higher level of safety and regularity of service, as well as improved passenger comfort.

Simplicity of operation and servicing, a full instrumentation and avionics package, as well as capability to take off from and land on austere airfields would make this aircraft a versatile air taxi.

Subsequently, utilizing the experience gained in designing the An-12 transport aircraft, Oleg Konstantinovich and his team designed in short order the An-10 primary-service passenger aircraft, capable of carrying more than 100 passengers. Boasting good takeoff and landing performance, this aircraft became the most economical aircraft of its class.

Continuing its finest traditions, the special design office, under Antonov's guidance, developed the 50-passenger An-24 aircraft, designed for medium-haul local-route service. It became the workhorse civil aircraft, easy to fly, service and repair, and engineered to the highest standards of structural strength.

The design office team headed by Antonov pioneered the development of heavy transport aircraft incorporating large cargo spaces in the main fuselage area.

The An-8 aircraft, capable of hauling a 6-ton payload a distance of 3,000 kilometers, ushered in the "Antonov" transport aircraft aerodynamic configuration, which became the standard. Two powerful AI-20 turboprop engines, wings with double-slotted flaps, and a fuselage with large, double doors constituted the embodiment of sophisticated mechanics and efficient means of loading, unloading, and lashing down large-size cargo.

Continuing further to develop the transport aircraft open configuration, the special design office team came up with the An-12 -- a transport aircraft powered by four AI-20 engines, with a load-lifting capacity of 15 tons and a range of up to 2,000 kilometers. For more than a quarter of a century it has been one of the principal aerial "trucks" of Aeroflot and our Air Forces.

The design office team's development of the world's first widebody aircraft, the An-22, which can transport 60 tons of cargo a distance of 3,000 kilometers, constituted a genuine triumph of Soviet transport aircraft engineering. It boasts four powerful NK-12MA turboprop engines, a wing with efficient high-lift devices, with utilization of high-strength molded panels and spars, a fuselage 6 meters in diameter with a large cargo hatch which is

shut with a loading ramp and single door. It employs large stampings for the main frames. Efficient loading and unloading devices as well as a reliable landing gear made this ship the pride of our aircraft industry.

Incorporating the superior design features of the An-24, reworking its fuselage with a unique cargo hatch incorporating a drop-type loading ramp on the underside of the fuselage [beavertail rear door], and nacelle-mounting a third engine, Oleg Konstantinovich and his colleagues produced the An-26 high-mobility transport aircraft.

Solid experience amassed in building aircraft, as well as successfully performed laboratory tests on new materials, aerodynamic studies of swept wings with new, powerful lift-augmentation devices, and modern advances in electronics enabled the design office to commence work on development of high-speed transport aircraft with excellent takeoff and landing performance characteristics.

Development of the An-72 aircraft, powered by two D-36 engines, confirmed that the special design office team had successfully solved problems connected with employment of the new turbofan engines, a swept wing with powerful lift-augmentation devices, composite materials, and a new avionics package.

Oleg Konstantinovich noted at an early date the great significance of ergonomic studies in designing the flight deck for the crew of a modern aircraft. Subdivisions were set up in the design office, specialist personnel were trained, and effective experimental facilities were set up. This made it possible successfully to accomplish the highly complex task assigned to the design team, involving development of a new widebody heavy-lift transport. The special design office team worked on designing this aircraft with enthusiasm and a strong sense of responsibility to the party and people. In the final analysis all engineer design decisions were optimized by means of competent engineering calculation and wind-tunnel aerodynamic studies, as well as flight tests.

The team worked enthusiastically on designing the new aircraft. As a result the giant An-124 aircraft, powered by four turbofan engines, capable of lifting 150 tons and with a range of 4,500 kilometers, came to fruition.

Improved airframe aerodynamic configuration and design, powerful, economical turbofan engines, and extensive employment of composite materials, in combination with an efficient system for on- and off-loading large and heavy cargo items received high praise from aviation experts at the 1985 International Air Show at Paris's Le Bourget Airport.

Possessing economic intuition, Oleg Konstantinovich sought to make maximum use of the capabilities of already existing aircraft to accomplish new specific economic tasks. Soon numerous modifications of basic-model aircraft appeared: a transport, ski, floatplane and other versions of the An-2. The An-24T was a modified version of the An-24, with cargo door in the tail part of fuselage; the An-24RV passenger version carried a third engine, while the An-30 was designed to perform aerial photography. Different variations of the An-28 aircraft were also designed -- forestry surveillance, geological exploration,

aerial photography, arctic, fish-locating, and flying ambulance. Several modified versions of the An-72 were also built.

The history of the design office headed for many years by O. K. Antonov runs from the An-2 to the An-124. It involved an intensive process of continuous innovation, when the most recent aircraft incorporated all the best elements of preceding models and was designed taking into account the latest scientific and technological advances.

The homeland has high appreciation for the contributions of aircraft chief designer and USSR Academy of Sciences Academician Oleg Konstantinovich Antonov, conferring upon him the title Hero of Socialist Labor. He was awarded the Lenin Prize and the State Prize, as well as many governmental honors.

Time is illuminating with increasing brightness the countenance of this gifted, astute expert and skilled aircraft designer. O. K. Antonov's innovative style was adopted by the entire special design office team, perceived and enriched by many capable senior designers and administrators, who have become his worthy successors.

The special design office team is currently working intensely and fruitfully on development of new aircraft. The team is headed by aircraft chief designer Hero of Socialist Labor and USSR State Prize recipient Petr Vasilyevich Balabuyev, who for many years was Oleg Konstantinovich Antonov's assistant and right-hand man.

COPYRIGHT: "Aviatsiya i kosmonavtika", 1986.

3024

CSO: 9144/206

HISTORY OF AIR-TO-AIR COMBAT REVIEWED

Moscow AVIATSIYA I KOSMONAVTIKA in Russian No 2, Feb 86 (signed to press 3 Jan 86) pp 34-35

[Article, published under the heading "Tactics and Simulation," by Military Pilot 1st Class Col Yu. Kislyakov and Candidate of Military Sciences Col (Res) V. Babich: "History of Aerial Combat"; second part of a series]

[Text] World War I was in progress. In anticipation of major military events on the Southwestern Front, the command authorities of the 1st Aviation Group took a number of urgent measures. In short order the combat efficiency of the group's component fighter detachments had been increased sharply. Equipment, supporting agencies and armament service were thoroughly readied for the forthcoming battles. Considerable attention was devoted to concealing and camouflaging aircraft and providing airfields with anti-aircraft defense. For a period of a month pilots studied the new Nieuports and Spads, while the gunner-aerial observers worked on mastering the improved machineguns. At a specially equipped range they practiced firing at fixed and moving targets and at balloons aloft.

Following each work-intensive day of flying, aviators would exchange views and opinions on individual and group aerial combat tactics. Several interesting variations were tested in the air. Pilots adopted only those tactics which correspond to the capabilities of the new aircraft and weapons. The aviation group contained experienced combat pilots who had scored air-to-air kills (Kazakov, Smirnov, Tkachev, Bashinskiy). They also passed on their experience and know-how to the novice pilots who had not yet experienced combat.

For the first time in the history of Russian aviation, a warning system based on forward-positioned ground-observation posts was established. The posts, deployed to the north and west of Lutsk, maintained communication with aviation group headquarters and would immediately inform headquarters upon spotting an enemy aircraft. Upon receiving a warning, with indication of strength and composition of the enemy force, direction and approximate altitude, headquarters would issue the command to send fighters aloft.

Flight personnel thoroughly studied the enemy's aircraft and tactics as well as his strong and weak points, which were to be taken into consideration in

combat. Special attention was devoted to the improved German Fokker which was escorting German bombers.

Considerable importance was attached to organizing teamwork and coordination with reconnaissance aircraft, escorting and protecting them above enemy territory. They worked out communications between fighters in the group in order to provide reliable mutual support in combat. Coordination with ground troops, especially with artillery, was set up. We should note that the commanding general of the Southwestern Front, Gen A. Brusilov, who fully acknowledged the significance of aircraft in support ground combat operations, personally monitored the aviation group's training and preparations and gave it every possible assistance, especially in the area of materiel supply.

The newspaper ISKRA carried an article appraising the operations of the 1st Fighter Group in the Lutsk area. "...a series of squadron aerial engagements were fought on the Southwestern Front, producing brilliant results: not one enemy aircraft succeeded in penetrating airspace above friendly troops, while our pilots were able to fly successful reconnaissance missions."

Interesting in this regard is an aerial engagement fought by a reconnaissance aircrew. Flying an old Farman, pilot Khodorovich and gunner-aerial observer Pirozhok took off on a mission. While en route Khodorovich suddenly heard the chatter of a machinegun. Looking around, he spotted a German aircraft attacking him from the tail. The pilot immediately throttled back and put his aircraft into a glide, so that the horizontal stabilizer would not impede the aerial gunner's fire. The adversary broke off at a range of 150 meters, fearing to be hit by a burst of machinegun fire. Since he was traveling at greater speed, however, he ended up ahead of and above the Farman. Khodorovich applied full throttle, turned toward the adversary and proceeded to climb. The adversaries began jousting for position to initiate an attack.

At the very height of the battle, two Russian Nieuports came to the reconnaissance aircraft's aid. Fighter pilot Kiselevich swung right into the attack. An accurate burst caused the German aircraft to pitch down, go into a spin, and crash into the ground. The reconnaissance aircraft crew successfully carried out their mission. The aerial reconnaissance mission unquestionably obtained better results due to the fighter support.

Of interest is the aerial engagement fought by G. Zverev, commander of the 4th Aviation Detachment in the Brailov area with a German "flying fortress." A twin-engine Rumpler carried a nose gunner cockpit forward of the wings, armed with a Parabellum machinegun, and aft of the wings -- a rear gunner cockpit with a turret-type machinegun. It was no easy feat to approach a Rumpler to effective fire range. Following a series of maneuvers, Zverev did manage to attack. He put a machinegun burst into the starboard engine of the "flying fortress," springing an oil leak, compelling the enemy pilot to make a forced landing. The victor returned home with 37 bullet holes, a twisted propeller, a holed oil tank, and a bullet hole in his own helmet.

Three additional Russian fighter aviation groups began to be formed in March 1917. The aircraft fleet was also upgraded. New aircraft included the fast Nieuport XXII and XXIII, as well as the Morane -- a monocoque design, armed

with machineguns firing through the propeller (with synchronizers). Aviation group flight personnel went through a course in advanced maneuvers in special departments of the Moscow, Gatchina, and Sevastopol Aviation schools. Prior to this time, in November 1916, 15 officer-pilots, including Ye. Kruten, commander of the 2nd Detachment, and I. Orlov, commander of the 7th Detachment, were sent to France to advanced pilot training and aerial combat school, after a probationary training period at which they were to take part in combat operations as French military aviators.

Aggressive fighter operations on the Russian-German front, which began in the fall of 1916, continued in the following year. Among aerial combat of varying character and content (with reconnaissance aircraft, bombers, artillery observers), we should make special mention of combat between fighters with machineguns (synchronized) rigidly mounted on the aircraft's longitudinal axis. This was a prototype of the air-to-air combat of World War II. The only difference lay in speed, amplitude of maneuvers (spatial scale of combat) and pace. They differed from previous aerial combat engagements in that fire was directed at that point toward which the aircraft's nose was aimed. The attack was figuratively called "fire movement forward." This was due to the design peculiarities of the highly-maneuverable single-seat fighter and strongly influenced air combat tactics.

The first published materials on tactics written by Russian fighter pilots appeared in 1917: "Material po taktike vozdushnogo boya" [Materials on Aerial Combat Tactics] by V. Tkachev, "Priyemy vedeniya vozdushnogo boya" [Techniques of Aerial Combat] by I. Orlov, and "Vozdushnyy boy" [Aerial Combat] by Ye. Kruten.

"Materials on Tactics" was written on the basis of experience obtained in the Lutsk area in the fall of 1916. V. Tkachev broke combat down into component elements, the first of which he called "ethical." He considered offensive and defensive combat to be combat categories. In selecting them he recommended that one bear in mind A. Suvorov's precept that "in battle the back is broader than the chest." The author devoted particular attention to professional training of the fighter pilot and his ability to exploit the strong points of his own aircraft and to "work on the adversary's weak points." In conclusion the author defined the principal stages on a pilot's road to victory: "Extensive acquaintance with matters pertaining to aerial combat; composure, which enables him correctly to assess the situation at a critical moment and to reach the appropriate decision; noble impulse, buoyed by valor, determination, and boldness; finally, maneuver and relentless fire into the target, without a miss...."

2nd Lieutenant I. Orlov, one of the finest Russian pilots, in his "Techniques" integrated his own personal combat experience with that of the French air aces, which he gathered during his tour of duty in France. He analyzed the techniques designed to achieve a high degree of flying proficiency and solid skills in spatial orientation. One of them was given to him by famed French flying ace (Ginemer): "The above mode of attack is the surest and at the same time the least dangerous, but it requires of the pilot a high degree of precision and knowledge of maneuvers. I personally tried it with some success, shooting down an enemy aircraft near Roix (France)."

It consisted essentially in the following: a pilot should place himself in an initial position 500-1,000 meters higher than the adversary and with the sun at his back. Then he should descend in a spiral, during which he should select a point at which to initiate a dive. This point should be in a sector where the enemy pilot's view was blocked (by parts of his aircraft). It was best to dive in a direction perpendicular to the adversary's heading. He should pass under the adversary during his descent, then loop his aircraft, completing the loop with a turn into the adversary, ending up 5-10 meters under his fuselage. In this position the adversary is wide open, while the attacking aircraft is shielded from return fire. If the attack fails, the pilot should go back and start from the beginning: withdraw, climb, etc.

Ye. Kruten in his manual examined aerial combat by stages and gave pilots specific recommendations. And, what is particularly important, he proposed a sensible and efficient organizational structure of fighter aviation, validated the specifications and performance characteristics of an aircraft designed for aerial combat, and advocated the establishment of a Russian school of tactics. The entire subsequent generation of Soviet fighter pilots learned from Kruten.

Just as Orlov, Kruten advised pilots only on that which he himself had tested in the air. He had shot down three enemy aircraft during his training in France. His techniques were not only skillful but intimidating as well, that is, adversely affected the enemy pilot's morale. On 26 May 1917, for example, he crippled two enemy aircraft with his Nieuport. In both instances Kruten, expertly maneuvering, forced the enemy to land. The first aircraft was manned by a German major with a great deal of combat experience, while the second carried a pilot and an observer. In order to accomplish a successful attack, Kruten exploited his altitude advantage to achieve rapid acceleration and to overtake the adversary.

Textbooks on tactics recommended for the most part attack from the rear hemisphere, which provided optimal firing conditions. In this configuration the speeds of the two aircraft would equalize, and therefore aiming and firing were performed as at a stationary target. The head-on attack was also examined. As was noted in "Materials on Tactics," however, the high relative closing speed (240-300 km/h) militated against this technique. Closing occurs so rapidly that the adversaries fail to hold through the attack and break away before they have reached close range. If an attack were followed through, it would last just seconds, during which not more than 10-15 rounds could be fired.

Nevertheless such an attack did take place once. At the end of April 1917 Senior NCO Zinovyev, patrolling over the forward edge of the battle area, spotted a German aircraft which was closing on him. The pilot immediately assumed a "sun to the back" position, facing the adversary head-on. The distance closed rapidly. Zinovyev was able to put his gunsight on the target and squeeze off a burst. He then broke away with a sharp banked turn. Hit by the accurate machinegun burst, the adversary plunged groundward. The engagement lasted 15-20 seconds. But danger still lurked for the bold Soviet pilot in a future engagement, waiting for just one tactical error during a head-on attack.

On 18 May Zinovyev began to close with an enemy aircraft head-on, moving toward the sun. Blinded by the sun's rays, the pilot was unable accurately to determine range to the target or to aim; he broke away. During his turn a machinegun burst pierced through his aircraft. Zinovyev was killed by a bullet in the head. The fatal error which cost this bold pilot his life of course did not scrap this new, complicated maneuver from aerial combat tactics. The head-on pass was successfully employed by Soviet air aces during the Great Patriotic War, especially against bombers. This was a tactic of intrepid combat pilots operating with composure and calculation.

What did the first Russian military pilots leave to posterity?

They demonstrated that success in aerial combat depends in equal measure on the quality of the aircraft and on the innovativeness of the pilots utilizing the aircraft's capabilities. P. N. Nesterov theoretically investigated and practically executed aerobatic maneuvers which marked the beginning of combat maneuvering. The loop was included in the first manuals on aerial combat in Russian, French, British, and German military aviation. The maximum-performance banked turn is a standard combat maneuver. In addition, the aircraft spin, first executed by Russian pilot N. N. Artseulov, was widely employed as a combat maneuver in aerial engagements.

The first Russian fighter pilots integrated advanced flying skills, skillful combat maneuvers and fire, laying down the principle of combining maneuver and fire. Ye. N. Kruten wrote that maneuver serves the attack and aims at "approaching the adversary to point-blank range, and only then opening sure fire." A pilot who possesses consummate mastery of flying skills but who lacks the ability to shoot falls within the category of sport flier, but he is not a combat pilot.

Analysis of the experience of fighter pilots among the principles of combat which were taking shape advanced to the forefront the principle of aggressiveness (boyevaya aktivnost), which has continued to be a leading factor right up to the present day. It was noted in "Materials on Tactics": "Any aircraft, regardless of its intended function, should immediately attack the enemy upon encountering him. Persistent pilot implementation of this principle will take down a peg or two an arrogant adversary who has attacked our unarmed aircraft with impunity. The aim and goal of fighter pilots is combat, determined combat at close range, since in such conditions one can confidently prepare oneself mentally for victory."

A successful outcome of air-to-air combat was directly dependent on gaining the element of surprise. Tactics placed particular emphasis on undetected approach to the adversary and the first attack pass, taking him by surprise. "Just as in any combat, but particularly in aerial combat, which is characterized by exceptional swiftness, it is essential to make every effort to employ the principle of surprise, exploiting a given situation. Surprise, first of all, gives the attacker the initiative (even if his aircraft is flying slower) and, consequently, the choice of a more convenient firing position, and subsequently better utilization of fire as well. In this case the attacker will also enjoy a considerable morale advantage -- the adversary,

taken unawares, will be unable instantly to assess the situation and will be delayed in opening fire."

The principal missions of fighter pilots were also defined, to which the performance characteristics (combat capabilities) of aircraft and weapons should correspond. These missions were as follows: gaining air superiority, providing air cover to ground troops, and supporting other air components. There have been many generations of fighter pilots in a historical period stretching 70 years, but they have all performed the combat missions formulated in the summer of 1916.

A most important place was assigned to professional training of flight personnel. In aerial combat victory in the final analysis was won by a pilot who had the ability to utilize the capabilities of his equipment with efficiency and who displayed excellent moral qualities. In preparing for combat, vanguard combat pilots would calculate maneuvers and combat tactics, practice variations on the ground and, when necessary, conduct experiments in the air (mathematical and full-scale simulation). Fighter pilots sought to emulate the aces, who had downed five or more enemy aircraft. World War I produced 26 Russian air aces, who downed a total of 188 enemy aircraft. Others learned from them, emulated them, and measured their own performance against them. (To be continued)

COPYRIGHT: "Aviatsiya i kosmonavtika", 1986.

3024

CSO: 9144/206

TRAINING PILOTS TO RESPOND CORRECTLY TO IN-FLIGHT EQUIPMENT MALFUNCTIONS

Moscow AVIATSIYA I KOSMONAVTIKA in Russian No 2, Feb 86 (signed to press 3 Jan 86) pp 36-37

[Article, published under the heading "Constant Attention to Flight Safety," by Military Instructor Pilot 1st Class Candidate of Technical Sciences Lt Col N. Litvinchuk and Candidate of Medical Sciences Maj Med Serv V. Kozlov: "Preparedness for an Emergency"]

[Text] Pilot cadet Yu. Yegorov was on a practice flight in a trainer aircraft. Suddenly he noted that the tachometer was reading zero. "Engine failure!" the pilot cadet concluded and immediately reported this fact to the tower. He then throttled back to idle. While performing air start procedures, he at the same time turned the aircraft in the direction of a forced-landing site and proceeded to descend. He was dropping in altitude, but the engine would not fire up -- the tachometer needle stubbornly clung to zero. On the flight operations officer's instructions the student pilot advanced his throttle, after which he joyously exclaimed into the mike: "The engine has started!"

Back on the ground it was ascertained that the student pilot had misinterpreted a tachometer failure as a flameout. It was not until he advanced the throttle and heard the increasing engine noise that he realized that the engine was running.

Such incidents are by no means isolated. There was also an incident where pilots took a flight deck air conditioner failure to mean engine shutdown.

The common element in such erroneous assumptions is the fact that what would seem to be obvious symptoms of one type of malfunction were taken by aircrews as symptoms of a totally different malfunction, with an incorrect analysis of the situation. Why does this happen? We shall endeavor to make a psychological analysis of the pilot's conduct in the incident cited above.

Student pilot Yu. Yegorov had discovered by chance that the tachometer needle was indicating zero. The facts were staring him in the face, as they say. And since there was no information indicating the instrument had failed, this signal became dominant, and the student pilot's thinking proceeded to work according to a stereotype which had formed during previous flights, which had

been without incident. That is, since the tachometer read zero, and it carried information on engine rpm, this meant that the engine had stopped.

This structure of the thought process is grounded primarily on blind faith in instruments. With a situation change, this leads to undesirable phenomena.

The decision made by the student pilot caused excessive neuroemotional stress in him. In this state his entire attention and thinking were concentrated around an erroneous conclusion. It did not even occur to the student pilot that the instrument could have failed, although he knew that such a possibility did exist. On the basis of jumping to a conclusion, an erroneous mode of action was formed, directed toward correcting the "emergency situation" which had arisen. Execution of the elaborated program, however, as it was based on a false conclusion, failed to produce the desired result.

Thus a thought process structure formed in the course of normal, uneventful flights formed the basis of the student pilot's erroneous conclusion that he had experienced engine shutdown. It turns out that the student pilot's entire preceding training failed to form in him the ability quickly and efficiently to analyze the situation and his own actions in emergency situations. Studies of the specific features of a pilot's activities in emergency situations indicate that if there is lacking experience in practical responses to instrument malfunctions, erroneous decisions are almost inevitable even for highly-qualified pilots. It has been proven that recognition of an emergency situation requires considerable experience of a pilot.

This is due to several reasons. First of all, in abnormal, unaccustomed situations the inflow of indeterminate information, in conditions of a psychological readiness to place a high degree of faith in the instruments, causes a certain degree of confusion, since there are lacking clear-cut indications of the correctness or erroneousness of their readings, especially if there is no redundancy. Secondly, in certain instances the information flowing to the pilot is similar in many respects. Thirdly, the outward appearance of a given malfunction, used in identifying an occurring abnormal situation and created in the process of training and preparing for flight operations, is not always in conformity with the appearance of the actual malfunction. Sometimes even the most detailed description of an emergency situation does not help in recognizing and identifying it in a prompt and timely manner, especially in conditions of a high degree of emotional stress. Frequently when information on an abnormal situation is received, an untrained pilot becomes flustered, is unable to collect his thoughts, and thinks the worst, which increases the probability that he will make an incorrect decision.

Experience amassed in studying pilot activities during in-flight emergencies persuasively indicates that so-called intellectual abilities and skills help to a great degree in grasping a difficult situation. It is precisely a lack of such skills which explains the fact that a pilot spends from 40 to 90 percent of the time in an emergency situation on processing information on what has taken place. This makes it much more difficult to make a prompt and timely decision. Therefore a paramount task in training to respond to emergencies consists in teaching flight personnel the ability to analyze

events and the developing situation in an intelligent and competent manner, to make correct decisions rapidly, and to practice and perfect response actions.

The basics for forming intellectual abilities and skills, with the existing system of training to respond to emergencies, are laid down in the process of study of theory, when the pilot studies the distinctive features of each situation and subsequently practices his response actions on the simulator.

One should bear in mind that the effectiveness of theoretical training can be substantially increased if the space-time structure of information proceeding to the pilot in each emergency situation (information diagram) is analyzed at this stage. The objective foundation of the information structure diagram is the fact that the evolution of each emergency situation is governed by strictly defined mechanisms, by knowing which one can determine the information which will flow to the pilot in an emergency situation, and subsequently reflect its interlinkage with changes in flight dynamics and the operation of individual aircraft systems.

As an example we shall analyze an information structure diagram in the case of the tachometer failure described in our example, and we shall compare it with the information structure diagram with flameout and control of a normally operating engine (see diagram).

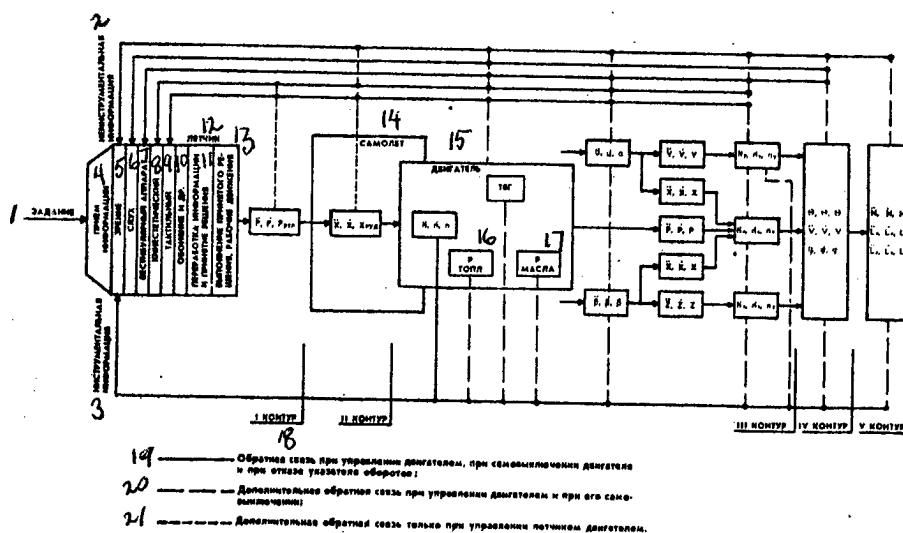

Pilot information structure diagrams during various conditions of flight.

Key: 1. Task; 2. Noninstrument information; 3. Instrument information; 4. Receipt of information; 5. Sight; 6. Hearing; 7. Vestibular mechanism; 8. Kinesthetic; 9. Tactile; 10. Sense of smell, etc; 11. Processing of information and decision-making; 12. Pilot; 13. Execution of decision, work motion; 14. Aircraft; 15. engine; 16. Fuel; 17. Oil; 18. Loop; 19. Feedback with engine control, with engine flameout, and with tachometer failure; 20. Additional feedback with engine control and with engine flameout; 21. Additional feedback only during pilot engine control.

It is evident in the diagram that with tachometer failure the pilot's information diagram consists only of one signal, received from the tachometer and indicating an rpm drop. This also occurs, however, when there is an engine flameout as well as during control of a normally operating engine. But in the latter two instances the information diagram is augmented by data on changes in flight dynamics and the operation of various systems and the powerplant (the pilot senses G forces, the noise level changes, exhaust gas temperature drops, etc). At the same time a distinctive feature of the information diagram during control of a normally operating engine is the presence of information in the first and second loops indicating pilot actions on the throttle.

We shall note that when the throttle spontaneously backs off, such as during arresting after touchdown, as well as when the pilot unintentionally moves the throttle during cockpit procedures, the information diagram can be the same as in the case of engine flameout. Therefore in order to prevent or, on the other hand, to determine for sure whether the engine has shut down, the pilot must check engine operation by advancing the throttle, a procedure which many operating manuals fail to emphasize. One should also bear in mind certain specific features of information diagrams in the process of training. They can be arbitrarily subdivided into two groups in relation to the flying process. The first is connected with aircraft control and is determined by the pilot's interaction with the equipment and systems which influence the aircraft's behavior: displacement of controls, extension and retraction of landing gear, flaps, etc.

The second group is not directly linked with piloting the aircraft and involves interaction between the pilot, equipment and systems which do not affect the aircraft's behavior (operation of radio gear, gunsight systems and the like). Information diagrams can be classified by the nature of the information coming to the pilot (by types of feedback) into active, semiactive, and passive.

The first as a rule are connected with flying the aircraft and depend on the dynamic properties of the aircraft and its parameters of motion. This category also includes information diagrams which incorporate intensive signaling devices. A distinctive feature of these is the fact that they have feedback in the form of accelerations, vibrations, and strong sound and light actions. In short they spontaneously draw attention and can cause spontaneous actions.

The second type of information diagram has intensive feedback, represented for the most part by visual stimuli which, although under certain conditions they can draw attention, do not cause involuntary actions by the pilot, since they require complex processing of information and decision-making; for example, light-up of the Generator Out annunciator.

Passive information diagrams incorporate feedback loops which do not cause involuntary switching of attention to them and which can make themselves known only during interaction between the pilot and the system proper. There is no other way to determine its malfunction. In these instances it is advisable to introduce automatic system status monitoring, with information on system

failure presented to the pilot. With this, a passive information diagram will become active or semiactive.

Systems that recognize and identify aircraft equipment malfunctions and flight situations and which provide the pilot with visual, aural or other information on such malfunctions are presently being developed and installed in aircraft. These systems are extremely essential, since aircrews operate in extremely time-critical conditions. But at the present time even these systems possess limited capabilities; therefore it is probable that in the immediate future they will not be able fully to resolve the problems they address. In addition, we must consider the possibility of failure or malfunction of the systems themselves and the possibility that they will put out incorrect information. Even with such systems on line, a pilot should have the ability to recognize and identify abnormal in-flight situations. This means that unrelenting attention must be devoted both to theoretical and flight-simulator training for emergency situations.

At this point we must emphasize that with an incorrect approach to developing abilities and skills to recognize and identify emergency situations, training activities on the cockpit simulator can play a negative role. This occurs when situations with active information structure diagrams are developed on static simulation stations. As is indicated by analyses of the information diagrams discussed above, in practicing responses to engine failure, in recognizing and identifying this situation on a flight simulator the pilot utilizes the same signals as with an instrument malfunction, which can lead to carryover of this habit to a flight situation.

We should note that considerable reserve potential connected with improving teaching and learning methods exists in the area of training flight personnel to respond to abnormal situations. Knowledge of information diagrams and their utilization in practical flight activities will enable military pilots to prepare to meet abnormal situations knowledgeably, with a precise concept and grasp of all incoming signals. And this unquestionably will increase the operational reliability of the "pilot-aircraft" system, and this means flight safety as well.

COPYRIGHT: "Aviatsiya i kosmonavtika", 1986.

3024

CSO: 9144/206

FIRST SOVIET SPACEWALK DESCRIBED

Moscow AVIATSIYA I KOSMONAVTIKA in Russian No 2, Feb 86 (signed to press 3 Jan 86) pp 42-43

[Article, published under the heading "Readers Request," by Hero of the Soviet Union M. Druzhinin: "Step Into the Unknown"]

[Text] Man's first spacewalk resulted in obtaining highly valuable information for subsequent manned missions. The entire world thrilled at the courage and daring of P. Belyayev and A. Leonov. This was an important stage in the development of space hardware and testing of its reliability.

Soviet cosmonauts have engaged in extravehicular activities time and again over the last 20 years, acquiring experience and know-how in performing complicated construction and assembly procedures during orbital flight. Thanks to this, following successful docking with the unmanned Salyut 7 station, the crew of the Soyuz T-13 spacecraft, consisting of V. Dzhanibekov and V. Savinykh, were quickly able to bring it back into operation, displaying exceptional courage and professional expertise. The crew of the fourth extended manned mission dedicated its work to the 27th CPSU Congress.

In response to a request by R. Gerchikova and T. Samkharadze, regular readers of this journal, we present below the reminiscences of Hero of the Soviet Union M. Druzhinin on man's first spacewalk. V. Lyndin prepared the accompanying table.

Pavel Belyayev, Aleksey Leonov and their comrades arrived from Moscow at the space launch center at the beginning of March 1965. It was a warm, sunny day, a frequent occurrence in the southern part of Kazakhstan this time of year.

By that time we were already familiar with the cosmonauts' biographies. Fighter pilot Pavel Belyayev, who was about 40, was born to a peasant family in Vologda Oblast. He saw action against the Japanese militarists in the last part of the Great Patriotic War. He graduated from the Air-Force Academy. He served as party organization secretary in the cosmonaut corps. Aleksey Leonov

was 30. He was born in Kemerovo Oblast, also to a peasant family, one of nine children -- six girls and three boys. Aleksey was the eighth.

A traditional get-together between the cosmonauts and the launch team was held on 17 March. The festivities were opened by party organizer Boris Ivanovich, a man with the wisdom of his many years of life experience, the soul and conscience of the launch team. Everybody respected him and affectionately called him "our red commissar." He invariably took part in all events at Baykonur, large and small, beginning with the launching of the first satellite.

Boris Ivanovich introduced to the assembled company the crew of the Voskhod 2 spacecraft and their backups. Spokesmen for the launch team reported to the cosmonauts that the booster and spacecraft were ready for launch and assured them that all prelaunch work had been performed conscientiously. Flowers were presented to the cosmonauts. Pavel Ivanovich Belyayev thanked the launch team for their warm welcome and good wishes.

It snowed during the night of 18 March -- a fairly uncommon occurrence in the area. The steppe had become completely white by 0500. Conditions were not entirely pleasant at the launch pad: it was raw and damp, and a cold wind was blowing.

...The cosmonauts strode impatiently across the snow-covered concrete slabs. Mission commander P. Belyayev, touching his pressurized helmet in a salute, reported in a clear and concise manner the crew's flight readiness. The chairman of the State Commission firmly embraced the cosmonauts and wished them a good flight.

"The mission assigned by the homeland will be carried out!" assured P. Belyayev.

Subsequently, on 21 March, Sergey Pavlovich Korolev, smiling, asked Leonov: "What was it I wished you at the time?"

"A favorable cosmic wind."

Sergey Pavlovich, clapping Aleksey affectionately on the shoulder, commented: "I was so nervous, Alesha, that I even forgot what the Chief Designer had wished you on your flight." And he added: "A favorable solar, not cosmic wind."

But let us return to the launch. Five minutes to liftoff was announced. We watched from the observation post as the service tower access beams retracted, as the sequencing commands rang out loudly over the speaker: "Key to launch!", "Prelim!" This was followed by: "Main!" We watched as the umbilical detached from the rocket.

Precisely at 0900 came the command: "Launch!" -- upon which the rocket lifted off smoothly and slowly, rocking slightly and picking up speed with each passing second, ascending upward through a cloud of dark smoke. Everybody was waving toward the departing rocket and shouting: "They're off! Way to go!"

Korolev's voice came over the speaker: "This is Dawn! How's it going, how do you feel? How are you handling the Gs?"

"This is Diamond! We feel fine, we are taking Gs well," replied Belyayev.

About 10 minutes went by. The Voskhod 2 spacecraft had begun its first orbit.

We went over to the TV monitors set up at the communications center. The members of the State Commission, scientists, designers, cosmonauts, and the media had gathered there. Sergey Pavlovich sat down next to the capcom. Everybody was waiting impatiently for that moment when the spacecraft and Aleksey, having begun his EVA, would appear on the monitors. We wondered what it would look like, for we had not read about anything of the kind even in science-fiction novels!

It was T plus 30 minutes. We heard the mission commander's voice: "This is Diamond! I am over the Soviet Union. We feel fine. We are commencing the experiment!"

"This is Dawn!" replied Korolev. "Very good. Proceed. We have a picture."

The airlock appeared on the TV monitor. Hands at first, followed by the cosmonaut's head in a pressurized helmet emerged from it. A moment later Aleksey Leonov was completely out of the airlock, in open space, grasping the tether joining him to the craft, and gradually releasing it. We watched as he secured a movie camera to the edge of the airlock opening. He then drifted upward, away from the craft, did a somersault, assumed a horizontal position, and proceeded to float along with the craft. He then waved one hand, followed by the other, spread his legs, and brought them back together. He repeated this sequence of motions several times. He performed all this slowly, smoothly, unhurried and at the same time, as we could sense, confidently.

We also listened to Belyayev's communications with Leonov. Pavel Ivanovich frequently repeated: "Take it nice and slow, Aleksey!", "Take it easy, Alesha, don't hurry!", "Don't forget to remove the lens cap!"

As I watched the TV monitor, my mind was filled with questions: how was he feeling, what sensations was he experiencing, and what was he thinking about? After all, this was taking place at an altitude of about 500 kilometers above the Earth and at an orbital velocity of 28,000 kilometers per hour. The scene took one's breath away.

Voices exclaimed: "Look, look, he has turned, he is floating with his arms and legs spread!"

"He waved! He is moving his legs, one after the other!"

At this point one could not help but recall Konstantin Eduardovich Tsiolkovskiy who, gazing far into the future of the conquest of space, wrote: "It is a frightful experience in this bottomless, boundless abyss, with no

familiar objects around. There is no ground under one's feet nor the terrestrial sky!!!"

This experiment took 20 minutes, 12 of which Leonov spent outside the spacecraft.

It would seem that all difficulties were behind them. But events developed in such a manner that on the following day these two courageous individuals, as well as those on the mission-support team, were faced with an additional, unscheduled ordeal. It was a first in the history of space exploration.

The landing under manual control required of the crew, and particularly of mission commander P. Belyayev, exceptional composure, concentration of attention, self-control and calmness....

On 21 March the heroes were welcomed back at the launch complex. Pavel Belyayev was the first to exit from the aircraft. He was dressed in a fur suit, an ear-flapped cap on his head, and wearing flight boots. He was followed by Aleksey Leonov, dressed in a similar fashion, but wearing a pilot's helmet. It was hard to recognize them in this garb.

The State Commission met about an hour later, and the crew presented a verbal report on the mission and the results of the EVA. A. Leonov replied to S. Korolev's question about what the Earth looks like from open space that if one looks straight at the Earth, at a 90 degree angle, the Earth appears flat, with a flat curved line running along the horizon.

"During the EVA," he went on, "both I and the mission commander felt like a pendulum: me at the bottom and him at the top, me at the top and him at the bottom."

Aleksey Arkhipovich then proceeded to relate in detail the EVA procedural sequence: "At first I released cautiously and even timidly the tether connecting me to the craft, but subsequently with increasing boldness. I finally floated away from the craft to the full tether length -- several meters. For some reason I kept being drawn toward the craft, although I was fully aware that both of us were traveling at the same orbital velocity...."

Pavel Ivanovich Belyayev reported on bringing the craft down manually. Neither he nor Leonov at the time knew the details of the entire complexity of their situation, involving malfunctions in the spacecraft attitude control system, and they were not aware of the very trying experience the chief designer had gone through. That moment was a difficult one for everybody, but especially for Korolev, who seemed to have aged and added gray hair during this brief time. But not for a single moment did he lose his cheerful spirits or confidence in a safe return and landing. The Chief Designer's mood and confidence infused the members of the State Commission, cosmonauts, and members of the media, everybody who was in his presence during these difficult moments. Subsequently, following the safe landing of the Voskhod 2, Sergey Pavlovich would state: "Yuriy Gagarin's flight ushered in the era of space navigation. But the era of man working in open space began on that day in

March when Aleksey Leonov exited from the airlock and floated freely in open space."

Discussing the future prospects of the space program, the Chief Designer emphasized time and again: "I am a great optimist and believe that manned missions of very considerable duration are not too far off."

Korolev compared space navigation with marine navigation: spacecraft, like seagoing and oceangoing vessels, would leave the earth for protracted periods of time. He dreamed of building large orbital stations for purposes of scientific research and also serving as a port for spacecraft. Sergey Pavlovich was already at that time giving thought to what he called space taxis, which would deliver to orbital stations individuals and entire cosmonaut relief crews, as well as provisions, space mail, tools and instruments, including power supplies. And, finally, EVA is an essential activity for the rescue of the crews of spacecraft in distress and to make manned space flight safer.

Today the dreams of S. P. Korolev and his teacher -- eminent Russian scientist K. E. Tsiolkovskiy, are coming true before our very eyes. In less than a quarter century the Soviet space program has accomplished a leap from the first flight of the Vostok spacecrat, carrying Yuriy Gagarin into orbit, to highly complex scientific orbital space laboratories, the Venera, Mars and other space probes, from a modest single-orbit mission to an almost 8-month stay in space and the performance of highly complex spacecraft docking operations, erection-assembly and arc welding operations on the exterior of a spacecraft. New and even more fascinating activities involved in the conquest of space lie ahead!

Extravehicular Activities by Soviet Cosmonauts

(Their names are given in the sequence order of spacecraft or orbital station EVA)

Date	Cosmonauts	Duration of EVA	Purpose of EVA
18 March 1965	A. Leonov	12 min	World's first spacewalk.
16 January 1969	Ye. Khrunov, A. Yeliseyev	37 min	Transfer from one craft to another by EVA.
20 December 1977	G. Grechko, Yu. Romanenko	1 hour 28 min	Examination and inspection of docking assembly and exterior structural components on the Salyut 6 station.
29 July 1978	A. Ivanchenkov, V. Kovalenok	2 hours 5 min	Takedown and partial replacement of scientific equipment mounted on station exterior.

Date	Cosmonauts	Duration of EVA	Purpose of EVA
15 August 1979	V. Ryumin, V. Lyakhov	1 hour 23 min	Detachment and removal of the antenna from the KRT-10 radio telescope, takedown of scientific equipment mounted on station exterior.
30 July 1982	V. Lebedev, A. Berezovoy	2 hours 33 min	Takedown and partial replacement of scientific equipment mounted on the exterior of the Salyut 7 station; investigation of the possibilities of performing assembly and installation operations using tools.
1 November 1983	A. Aleksandrov, V. Lyakhov	2 hours 50 min	Mounting of an additional section on the solar battery central panel.
3 November 1983	A. Aleksandrov, V. Lyakhov	2 hours 55 min	Mounting a second additional section onto the solar battery central panel.
23 April 1984	V. Solovyev, L. Kizim	4 hours 15 min	Setting up a work station on the station's equipment bay and commencement of repair of the integrated propulsion unit (ODU) backup main.
26 April 1984	V. Solovyev, L. Kizim	5 hours	Determination of location of seal leak, repair on station ODU backup main.
29 April 1984	V. Solovyev, L. Kizim	2 hours 45 min	Installation of ODU additional main.
4 May 1984	V. Solovyev, L. Kizim	2 hours 45 min	Installation of second additional ODU main.
18-19 May 1984	V. Solovyev, L. Kizim	3 hours 5 min	Installation of two additional sections on the solar battery lateral panel.
25 July 1984	V. Dzhanibekov, S. Savitskaya	3 hours 35 min	Tests on general-purpose manual electron-beam unit designed for cutting, welding, and brazing metals and application of metal coatings.
			World's first spacewalk by a female.
8 August 1984	V. Solovyev, L. Kizim	5 hours	Completion of repairs on ODU, pinchoff of seal-leaking main.

Date	Cosmonauts	Duration of EVA	Purpose of Eva
2 August 1985	V. Savinykh, V. Dzhanibekov	5 hours	Installation of two additional sections on the third, last panel of the Salyut 7 station solar battery.

COPYRIGHT: "Aviatsiya i kosmonavtika", 1986.

3024

CSO: 9144/206

OFFICERS RECALL GAGARIN'S EARLY MILITARY FLYING

Moscow AVIATSIYA I KOSMONAVTIKA in Russian No 2, Feb 86 (signed to press 3 Jan 86) pp 44-45

[Article, published under the heading "History of Aviation and the Space Program" by N. Varvarov: "Gagarin's Flying Career"; concluding part of two-part article, see AVIATSIYA I KOSMONAVTIKA, No 1, 1986]

[Text] Beyond the Arctic Circle

The years as a pilot cadet passed swiftly, filled with intensive study and flying. Passing the government examinations with a mark of excellent, Lieutenant Gagarin earned the right to choose where he would be assigned. He could go to the central region, to the south, or remain at Orenburg as an instructor pilot. The family of his wife, Valentina Ivanovna, lived in Orenburg. But Yuriy's passionate, restless heart yearned to go where life was hard. He went to a duty assignment beyond the Arctic Circle, together with service-school buddies Nikolay Repin, Valentin Zlobin, and Yuriy Dergunov.

"Lieutenant Gagarin arrived at our unit on 28 November 1957," relates former aviation regiment deputy commander for flight training Lt Col Nikolay Sergeevich Vilyamskiy. "He was assigned to the 3rd Squadron. It was commanded by Captain Reshetov, with deputy commander Captain Vdovin; his flight commander was Senior Lieutenant Vasilyev, and Captain Roslyakov was party organization secretary."

"Winter was in full swing. The base was in the midst of a deep Arctic night. The airfield is surrounded by mountainous terrain, and this naturally made flight operations more difficult. Another danger lurked in waiting for the pilot near the runway threshold: downdrafts could pull an aircraft on final into a rocky ravine, along the floor of which ran a small creek. It was essential rigorously to maintain glidepath and promptly to lower the gear at the proper time. The young pilots learned well these and other peculiarities of our flight operations area, and in March 1958 we proceeded to put the lieutenants through the dual flight training schedule, followed by proficiency check rides.

"They gradually increased the work load on the young pilots, increased the complexity of their air work, and would introduce surprise training scenario

instructions. As a part of mastering quickness of response to change in the leader's position during formation flight, I would customarily maneuver to break away from my wingman and take off behind clouds. On numerous occasions I flew check rides and graded training sorties with Yuriy in VFR and IFR weather, day and night, at high altitude and low level, involving air-to-air combat and 'aggressor' aircraft intercept out at sea.

"I particularly remember a performance-checking mock air-to-air engagement. The sky was dotted with cumulus, which made it hard to get one's bearings. Prior to reaching the designated combat practice area I decided to check Gagarin's speed of reaction to change in the leader's position. I ordered him over the radio to do an airspace scan, and then I suddenly broke away from him and headed behind some cumulus clouds. Yuriy did not lose sight of my aircraft and maintained formation, which not everybody was able to do.

"Gagarin did just as well on a performance-graded flight at night under the hood. I tested his resistance to spatial disorientation, that is, his ability correctly to interpret the performance, control and navigation instrument readings. I diverted his attention and then executed a sharp turn. Once again, however, Yuriy handled the situation well."

"Gagarin had a good eye," recalled flight commander Leonid Danilovich Vasilyev. "He was able flawlessly to determine distance to the ground. But once the weather got the best even of him. Returning from a training sortie, Yuriy figured his approach with precision and touchdown right on the numbers. Everything seemed to be going well, but the aircraft, instead of stopping, kept rolling down the runway, failing to respond to the brakes. At this point Gagarin literally stood on the brakes. And then the unforeseen occurred -- the aircraft proceeded to slide. It seems the runway had unexpectedly iced over, and the abrupt braking had prompted loss of traction. Gagarin, who was encountering this phenomenon for the first time, although he had heard about it from the veteran pilots, was very upset at what had happened.

"We were having a nice, clear, sunny April day. Yuriy was aloft when a low-pressure area suddenly moved in from the sea. The airfield suddenly became shrouded in fog. You could hear nothing but crackling over your headset. The flight operations officer became quite concerned: there was virtually nothing he could do to assist Gagarin. All the emergency equipment was made ready, and the runway lights were turned on. Having completed his training mission, Yuriy attempted to shoot an approach. It was no good: although he descended practically to the deck, he was unable to establish visual contact with the ground. Should he abort his approach? Just as he had decided to add power, he suddenly spotted the runway lights off in the distance...."

"Day by day, month by month, Yuriy amassed experience and acquired the requisite skills," related Boris Fedorovich Vdovin, acting deputy squadron commander at the time. "He was a romantic, and he would express his delight with flying, the sky, and the ground with the phrase: 'What beauty!' Veteran aviators know that you shouldn't become distracted in the air, since a pilot should not divert his attention from monitoring the readings of dozens of instruments or lose his bearings when airborne. Therefore when Yuriy once spoke his favorite phrase, Vasilyev, who was flying dual with him, commented:

'Don't get distracted from the instruments. Save your emotions for later. Right now you have a job to do!'

"At the post-mission critique session I said to Yuriy: 'You were marveling at how beautiful it was up there. But what was the altitude and heading of that pair of aircraft you, to put it mildly, failed to spot at that moment?'

"Yuriy's face fell.

"'Never forget this: if a real adversary had been up there in the sky, there would be nothing left of your romanticism but duralumin fragments. Romanticism is of course a necessary thing, but the combat mission is more important than all else.'

"Once I was engaged in 'free air combat' with Gagarin. This is when two pilots, wheeling about one another, intricately maneuver in the attempt to get onto the other's tail and 'fire' their gun camera. The time allocated to the training activity had run out, but neither Yuriy nor I had been able to maneuver into an advantageous 'firing' position. Back on the ground I said to him: 'Nice going; you are starting to put the pin on your teachers and are developing your own flying signature. Keep up the good work!'

"A snowy month of February had come to an end," related squadron commander Vladimir Mikhaylovich Reshetov, "and we had begun flying dual with the novice pilots. Soon the flight commander informed me that Lieutenant Gagarin was ready to solo. Well, that was fine. I ordered a dual trainer made ready to go up.

"Our MiG trainer, lifting off after a short takeoff roll, swiftly climbed out and veered from its departure heading. 'Not bad,' I said to myself, because two hills had popped up directly ahead of us on takeoff. But this was just the beginning. I had to test Gagarin's capability to fly in IFR weather, when you have to fly on instruments alone. At my command the young pilot donned the IFR hood. He would be flying the aircraft blind. After checking to see how he maintained heading, I ordered him to do a 360 degree turn at a 30 degree bank. Gagarin carried out all instructions with precision, and the instruments corroborated this fact.

"Fine. But how would he do if some important instrument suddenly failed? Without a single word of warning, I flipped a toggle switch and disabled the ADF. The pointer proceeded to drift. In this situation some pilots begin 'chasing' it, changing their heading back and forth. In my static-filled headset I heard Gagarin's voice: 'ADF malfunction, request vector to field.'

"When he had performed all the required procedures and had turned to the correct heading, I said to him, satisfaction in my voice: 'Remove the hood, Yuriy. Head for home. You're doing just fine.'

"Gagarin always gave the impression of dependability. He carried out everything he was assigned. He paid careful heed to the advice of the "old-timers," who had acquired the skills of flying on hill-studded terrain and over the sea in changeable, adverse weather. He had a good memory -- an

important quality for a fighter pilot. When flying at our speeds there is no time to compare the chart with the terrain. One must have the ability instantly to recognize every fjord, creek and bend in the road, even dozens of kilometers from the base. Gagarin had this ability."

"Don't Make Things Too Easy for Them!"

"One day in December 1957," recalled Komsomol committee secretary Leonid Yuryevich Khomenko, "a young officer entered the room housing the Komsomol committee.

"Lieutenant Gagarin,' he introduced himself. 'Please put me on the books.'

"I learned from Gagarin that he had known quite a variety of life experience. There were also some very difficult times, but he did not place emphasis on these. We sort of naturally shifted over to the familiar form of address, and I asked him: 'Yura, you graduated at the top of your class. How did you end up in the Arctic? There are so many fine Air Forces garrisons in areas with an excellent climate!'

"Upon thinking a moment, he replied: 'Long before our final examinations, my friends and I decided to obtain duty assignments in the Arctic. In this region one can develop excellent flying proficiency in a short period of time.'

"I had to agree with them. He was thinking about his career future even then, in his early years. Following a long conversation, we parted as comrades.

"At a Komsomol meeting Gagarin was nominated to the Komsomol committee. He was placed in charge of athletics. We realized that in order to be a fighter pilot, to fly night and day over the boundless expanses of the Barents Sea in all weather, fair and foul, one needs not only sophisticated practical flying skills but also good physical conditioning and endurance. Athletics could provide these qualities. This is why the Komsomol committee was doing everything it could to ensure that sports became an integral part of each and every pilot's daily life.

"The following incident indicates the degree of responsibility with which Yuriy Gagarin set about his work assignment. Once at an open Komsomol meeting he asked for the floor.

"We have plenty of time available for winter sports. We have snow on the ground for 8 and sometimes even 9 months out of the year. But who of us would not like to play a little volleyball, basketball or other games right now?'

"In the snow?' came a voice from the audience.

"Certainly, if one wanted to. But that is not my point. We need a gymnasium, and I believe that we ourselves can build one.'

"He proposed that we submit a requisition request to the rear services people for a prefab storage building, gravel, cement, bricks, nails, and other

building materials. The regimental commander threw its support behind this initiative.

"The pilots, technicians, mechanics, rear services and technical maintenance unit specialist personnel worked almost 4 months, in their time free from flight operations and training activities, building the gymnasium. Gagarin's enthusiasm, eagerness and energy infected the rest of the men as well. The gymnasium was ready to go 3 months ahead of schedule. It offered a basketball court, a volleyball court, chinup bars, and parallel bars. An area was set aside for weightlifting, wrestling and boxing. We even built stands for spectators. In our opinion there was not a better sports facility at that time anywhere in the Arctic. The command authorities awarded Certificates of Merit to many of the men. One of the first to receive one was Yuriy Gagarin.

"I recall a day of intensive flight operations. Combat aircraft were taking off one after the other. Yuriy was sitting by the window in the pilot lounge shack waiting for the order to head out. I went over to him and asked him how he was feeling. We talked a little about committee affairs. I then asked him: 'Yura, are you thinking about joining the party?'

"He peered intently at me, and then said: 'I have been thinking about it for quite some time, but is it not a bit premature?'

"'Considering your activities and your training, the time is now.'

"'Then I shall begin with our Komsomol organization. It should have the first word in this important matter,' he stated with enthusiasm.

"That same day, after flight operations were completed, I wrote Yuriy Gagarin, on behalf of the unit Komsomol committee, a recommendation for membership in the CPSU.

"After his acceptance to party probationary membership, Yuriy took on more volunteer work: he was assigned to put out a news bulletin. He approached his new task assignment with a serious attitude, and on every flight operations day he managed to discuss in a news bulletin the successes of his comrades.

"Today the entire world is familiar with Yuriy Gagarin's kind, engaging smile, which fairly radiates his warmhearted nature. But I also remember him as stern and very serious. At Komsomol committee meetings Yuriy would state issues in a firm, incisive manner. He was no pussycat, nor was he ever mean and sarcastic. He considered it his duty to speak out on a matter under discussion at all times. I recall how at a Komsomol committee meeting we were discussing the conduct of a young pilot guilty of a breach of preflight preparation discipline. Gagarin demanded the severest punishment.

"'Getting proper rest before flight operations is not your own personal business,' he said. 'Composure and precision of actions in the air depends on the rest you get.'

"We issued a reprimand to the Komsomol member. Gagarin had convinced us that this punishment was fair and just. He himself always prepared very

conscientiously for every training sortie and rigorously adhered to the requirements of preflight preparation.

"At the end of April 1961 we received a letter from the world's first cosmonaut. Yuriy Alekseyevich wrote: 'Dear friends and regimental colleagues! Thanks for your message of congratulations. I often think of you, my comrades and command personnel. You gave me a great deal in the regiment and squadron. Of course at that time I was just beginning the journey which took me into space. And my superiors, fellow soldiers, good friends and acquaintances, to whom I still feel a closeness, helped me accomplish this great journey. Dear friends, have feelings of love for our Soviet skies and safeguard them as a most precious possession! I greet you warmly. As ever, Gagarin.'"

COPYRIGHT: "Aviatsiya i kosmonavtika", 1986.

3024

CSO: 9144/206

SOVIET BALLOON SONDES PROBE VENUSIAN ATMOSPHERE

Moscow AVIATSIYA I KOSMONAVTIKA in Russian No 2, Feb 86 (signed to press 3 Jan 86) pp 46-47

[Article, published under the heading "The Space Program Serving Science and the Economy," by V. Balebanov, deputy director of the USSR Academy of Sciences Institute of Space Research: "Toward Halley's Comet"; second part of three-part article; first part appeared in AVIATSIYA I KOSMONAVTIKA, No 1, 1986]

[Text] Selecting a trajectory path toward Halley's Comet for the Vega 1 and Vega 2 probes which included a close flyby past the planet Venus made it possible to prepare and utilize a single space vehicle to perform several tasks. The first of these tasks is continuation of the program to investigate Venus begun by Soviet unmanned probes. V. Balebanov, deputy director of the USSR Academy of Sciences Institute of Space Research, discusses the methods and some of the results obtained during this phase of the mission.

2. Encounter With the "Morning Star"

At the beginning of June 1985 Vega 1 and Vega 2 reached the vicinity of Venus, having covered a distance of approximately 500 million kilometers in a period of 6 months. Forty-eight hours prior to reaching the closest point of approach to the planet, descent vehicles were separated from the probes; upon entry into the Venusian atmosphere, these vehicles in turn separated into a lander and a balloon sonde. This was accomplished as follows.

As the descent module traveled through the atmosphere, it was placed into the correct attitude by displacing the center of gravity relative to the center of symmetry. After vehicle speed had bled off to below escape velocity, signals generated by a G forces detector caused the parachute container cover to be shot off, and the withdrawal chute was deployed. Detonation of a ring-shape explosive cartridge then cut the descent module's heat-shielding sphere in half. The upper hemisphere proceeded upward together with the balloon sonde. After the sonde was released, the first stage of the balloon parachute system was actuated (see diagram).

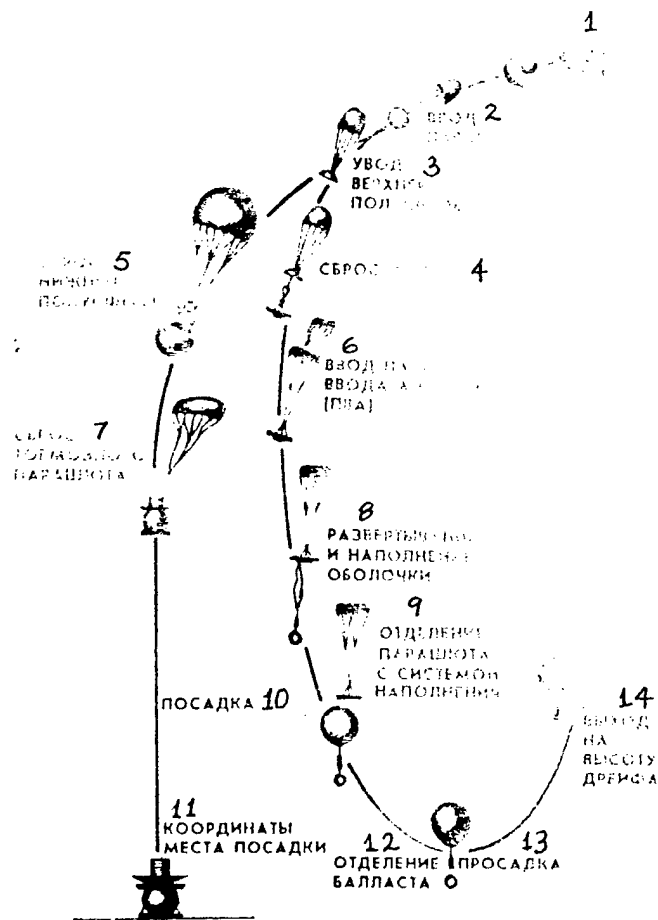

Diagram of Aerostat experiment.

Key: 1. Entry; 2. Withdrawal chute deploys; 3. Withdrawal of upper hemisphere; 4. Release of sonde; 5. Release of lower hemisphere; 6. Deployment of balloon deployment parachute (PVA); 7. Release of drag chute; 8. Deployment and filling of balloon; 9. Separation of chute with filling system; 10. Landing; 11. Coordinates of landing site; 12. Separation of ballast; 13. Settling; 14. Climb to drift altitude

Initially the sonde rode on a stabilizing chute. The latter decelerated the vehicle and, after accomplishing its task, handed things over to the 35 square meter balloon deployment chute, which decelerated the container to the desired velocity. Then explosive charges blew open the balloon container, which separated into halves. The lower half, descending, pulled out the soft balloon skin and gondola. Another explosive cartridge detonated, allowing helium to pass through from pressurized tanks into the balloon gas bag. It took 250 seconds to fill the balloon. Explosive charges then separated the chute together with part of the balloon container and compressed-gas cylinders. The ballast was then released, and the balloon climbed to drift altitude.

During this same time the lower half of the shell, together with the landing vehicle, was continuing to descend with the braking chute to an altitude of 63 km. At this point it separated from the landing vehicle, and after another kilometer the braking chute was released. By this time the descent vehicle's rate of descent had decreased to 20 m/s, with subsequent deceleration caused by the vehicle's aerodynamic shield. The rate of descent was approximately 7 m/s at the moment of touchdown. The energy of impact was absorbed by a special device in the form of a thin-walled toroidal shell, which underwent plastic deformation at the moment of touchdown. It also positioned the vehicle in a proper attitude after touchdown.

Both balloons were deployed on the night side of the planet, almost at the antihelical point. They subsequently drifted with the wind to the day side, with data transmitted to the Earth for a period of 46 hours. Each covered a distance in the order of 12,000 kilometers, traveling at an average speed of 250 km/h. The first balloon drifted along the equator in the northern hemisphere, and the second in the southern hemisphere.

This was the first balloon sounding of the Venusian atmosphere, and its significance can scarcely be exaggerated. It provides answers to a number of major problems of the planet's physics which cannot be resolved with the aid of landing systems. In particular, it enables us to obtain data on the nature of Venusian global atmospheric circulation (the so-called superrotation phenomenon). In general terms this circulation can be viewed as a global cyclone which spins the atmosphere with a period of 4 days.

It is not yet clear just what supports such rapid circulation, for the temperature is practically identical on the day and night sides of the planet, and there are no reasons for atmosphere thermal return flows. Venus itself turns very slowly on its axis, and at the planetary surface the wind velocity, measured by landing vehicles, is small -- approximately 1 meter per second, as was to be expected.

By investigating the circulation of the Venusian atmosphere, one can obtain very valuable applied data which will help us gain a better understanding of the dynamics of our own atmosphere and help elucidate the mechanisms which influence long-period climate variations on Earth. For this it is important to study not only atmospheric motions on a various scale in the Venusian atmosphere but both the physical principles and consequences of these movements. In other words, in addition to motions proper, scientists are interested in the temperature and pressure field, horizontal and vertical cloud layer structure, the optical properties of the atmosphere, etc. Investigations of Venus with the aid of balloons drifting in that planet's atmosphere should also provide considerable information to help clarify these questions.

A balloon sonde consists of two systems: the balloon proper (a gas bag 3.4 meters in diameter, made of fluorolon varnished cloth) and a gondola, which is suspended from the balloon by a 12-meter line. The gondola contains meteorological package instruments, power supplies (chemical batteries), and a radio transmitter. The meteorological package includes instruments to measure temperature and atmospheric pressure, wind velocity vertical component,

optical density of the cloud layer, and illumination. All instruments are "queried" simultaneously every 75 seconds, with data recorded and stored. The total volume of information collected in each 30-minute period is transmitted to Earth.

The world's largest radio telescopes, linked up as interferometers, received signals from the balloon sondes and determined their location and velocity.

The interferometer method consists essentially in the following: observations are made simultaneously by two or more radio telescopes located as far as possible from one another. In this case the angular resolution of observations is determined not by antenna dimensions but by distance between telescopes -- the interferometer's base line. Thus one can obtain a resolution 1,000 times better than with optical telescopes, which makes it possible accurately to track sonde movement across the Venusian disk.

Two radio telescope networks were established -- a Soviet, coordinated by the USSR Academy of Sciences Institute of Space Research, and an international, coordinated by France's National Center for Space Research. Our network contains two 70 meter radio telescopes -- at Ussuriysk and Yevpatoriya, a 64-meter radio telescope at Medvezhye Ozera (Moscow Oblast), two 22-meter radio telescopes -- at Pushchino (on the Oka) and Simeiz (Crimea), as well as a 25-meter radio telescope at Ulan-Ude.

The international network includes 64-meter radio telescopes at Goldstone (United States), Canberra and Parks (Australia), and Madrid (Spain), a 100-meter radio telescope at Eifelsberg (FRG), plus a number of medium-size telescopes in Europe, North and South America, and in Southern Africa. According to estimates, the aggregate accuracy of measurements of the coordinates of the balloon sondes ranges from 10 to 30 km (depending on their position on Venus), while accuracy of velocity measurement is in the order of 1 meter per second.

A complete interpretation of data obtained from the experiments with the balloon probes will be performed by a team of Soviet, U.S., and French scientists. It is projected that scientific results will not be obtained earlier than January 1987, so great is the obtained volume of information. Therefore at this point we can discuss only preliminary data.

First of all extraordinarily strong (by terrestrial measure) vertical wind gusts were recorded, exceeding 1 meter per second. For comparison, we should note that on the Earth vertical wind gusts do not exceed centimeters per second. This attests to highly developed turbulence in the Venusian atmosphere at altitudes in the order of 54 km, that is, in the balloon drift zone.

On the planet's night side the balloons' scientific instrumentation recorded variations in level of illumination as well as light flashes. Their nature is not entirely clear at present: they are possibly bolts of lightning (storm phenomena were detected in the Venusian atmosphere by the descent vehicles of the Venera 11 and Venera 12 probes) or volcanic eruptions. Perhaps it is both. We might recall K. Bryullov's painting "Last Day of Pompeii" --

lightning flashes above an erupting Vesuvius. In any case scientists attempted to explain variations in sulfur dioxide content in the Venusian atmosphere with a volcanic eruption hypothesis.

One thing is without question: the balloon experiment is one of the most important scientific and technical achievements of the Soviet space program. It opens up new possibilities in investigation not only of Venus but Jupiter as well.

While the balloon probes drifted in the Venusian atmosphere, the landing vehicles descended directly to the planet surface. Scientific investigations with the aid of these vehicles began during descent through the atmosphere. Instruments to measure atmospheric pressure, average temperature values and surges were switched on immediately following deployment of the braking parachute.

One of the main tasks in investigating the cloud layer in the Venusian atmosphere consisted in obtaining detailed knowledge of the photochemical processes responsible for its formation. It was hypothesized on the basis of previously obtained indirect data that the clouds consist for the most part of sulfuric acid (with a 75-85 percent concentration) with an admixture of chlorine. Nevertheless up to the present time there have been no direct determinations of sulfuric acid in the cloud layer. Nor do we know in what form chlorine is present in the clouds. An answer to these questions is extremely important in order to understand the global geochemistry of Venus. And for this we must obtain reliable and complete information on the chemical composition of the atmosphere and cloud layer as well as on the properties of the particles which form it. Investigations were carried out by a package of instruments which mutually supplemented one another. And immediately the SIGMA-3 gas chromatograph recorded with certainty the presence of sulfuric acid as a chemical compound in the Venusian clouds.

For the first time an ultraviolet spectrometer measured absorption of atmospheric gases at altitudes ranging from 60 kilometers right down to the planet surface.

Special analyzers carried by the descent vehicles made it possible not only to determine the diameter of each individual particle in the cloud layer but also to estimate their shape. Data on seven randomly selected particles was transmitted to the Earth each second. We were able to determine that the number of particles roughly 5 microns in size is approximately 100 per cubic centimeter, while below 40 kilometers the concentration increased to 1,000 per cubic centimeter. The size of particles decreases with decreasing altitude. Their diameter is less than 1 micron below 40 kilometers.

Another instrument -- a phase transition indicator -- determined by X-ray radiometric method the element composition of the cloud layer and, in addition, provided information on aerosol mass density in relation to altitude. Mass density in turn contains information on cloud layer structure. The obtained data indicated that the clouds on Venus possess a complex stratified structure. The Vega 1 descent vehicle, for example, detected no

fewer than 5 tiers of clouds. There are, in addition, indications that the Venusian clouds may also contain iron compounds.

The landing vehicle of the Vega 2 probe analyzed the chemical composition of the soil at the landing site, that is, determined the concentration of the principal rock-forming elements, from magnesium to and including iron, as well as several heavier rare elements. The studies were conducted by the X-ray radiometric analysis method. It is based on the relationship between the characteristic emission excited by an isotope source and the content of the element being analyzed in the sample. Soil in the analysis zone was obtained with a special soil-collecting device, which is capable of taking samples by drilling rock of practically any hardness (in conformity with terrestrial types). Drilling depth, volume and mass of the specimen are determined by the vehicle's specific operating conditions.

The chemical composition of the planet's soil was determined for the first time by this method in 1982 by the Venera 13 and Venera 14 probes. The new vehicle's landing site is located many hundreds of kilometers from previous sites, and this was the first landing in a high-mountain region. Analysis of the soil at various points of the planetary surface will enable us on the one hand to judge the diversity of rock types on Venus and, on the other hand, to construct more accurate models of the chemical interaction between planetary surface and atmosphere. Initial data have shown that the soil composition at the new site differs from that examined at previous landing sites.

In order to determine the nature of the Venusian rocks pertaining to content of natural radioactive elements -- uranium, thorium, and potassium -- we also measured the flux and spectral composition of gamma radiation of Venusian surface rocks at the probe landing site.

In summary we should emphasize that launching of the new Soviet unmanned probes will make it possible to solve many important problems in the study of our closest neighbor of the terrestrial group of planets -- Venus. For the first time information has been obtained on the dynamics of the Venusian atmosphere with the aid of balloon probes, as well as additional data on the chemical composition and structure of its clouds, and sulfuric acid content in the planet's atmosphere has been determined by direct methods. New data have also been obtained on small admixtures in the atmosphere. Finally, the element composition of the soil has been determined at a new descent vehicle landing site.

Processing and analysis of these data will make it possible on a considerably higher level to approach as yet undiscovered secrets of planetary cosmogony and comparative planetology. A rendezvous with Halley's Comet also lies ahead. (To be concluded)

COPYRIGHT: "Aviatsiya i kosmonavtika", 1986.

3024

CSO: 9144/206

- END -