

REPORT DOCUMENTATION PAGE			Form Approved OMB NO. 0704-0188	
Public reporting burden for this collection of information is estimated to average 1 hour per response, including the time for reviewing instructions, searching existing data sources, gathering and maintaining the data needed, and completing and reviewing the collection of information. Send comment regarding this burden estimate or any other aspect of this collection of information, including suggestions for reducing this burden, to Washington Headquarters Services, Directorate for Information Operations and Reports, 1215 Jefferson Davis Highway, Suite 1204, Arlington, VA 22202-4302, and to the Office of Management and Budget, Paperwork Reduction Project (0704-0188), Washington, DC 20503.				
1. AGENCY USE ONLY (Leave blank)	2. REPORT DATE 08/28/98	3. REPORT TYPE AND DATES COVERED 08/15/95 - 08/15/98		
4. TITLE AND SUBTITLE Smart Antennas for Battlefield Multimedia Wireless Networks with Dual Use Applications			5. FUNDING NUMBERS DAAH04-95-1-0249	
6. AUTHOR(S) Professor Arogyaswami Paulraj				
7. PERFORMING ORGANIZATION NAME(S) AND ADDRESS(ES) Stanford University Stanford, CA 94305			8. PERFORMING ORGANIZATION REPORT NUMBER FRI/96/3	
9. SPONSORING / MONITORING AGENCY NAME(S) AND ADDRESS(ES) U.S. Army Research Office P.O. Box 12211 Research Triangle Park, NC 27709-2211			10. SPONSORING / MONITORING AGENCY REPORT NUMBER ARO 34002.1-EL-FRI	
11. SUPPLEMENTARY NOTES The views, opinions and/or findings contained in this report are those of the author(s) and should not be construed as an official Department of the Army position, policy or decision, unless so designated by other documentation.				
12a. DISTRIBUTION / AVAILABILITY STATEMENT Approved for public release; distribution unlimited.			12 b. DISTRIBUTION CODE <b>19981222 112</b>	
13. ABSTRACT (Maximum 200 words)  Work under this contract focused on algorithms for space-time processing (STP) address the critical needs of the wireless battlefield network including high speed data, enhanced coverage and capacity, low power, and anti-jam capability. STP, also known as smart antennas, has application in battlefield multimedia distributed wireless networks and can readily be conformed to civilian mobile communications. Significant progress was made in the areas of space-time channel modeling, space-time receiver algorithms, and space-time transmit algorithms. It was shown that smart antenna enabled systems are capable of improving performance in severe multipath environments, in the presence of co-channel interference, and with unknown or variable antenna geometry. Many of the proposed algorithms were ultimately demonstrated in a TDMA smart antenna testbed built at Stanford.  <b>DTIC QUALITY INSPECTED 3</b>				
14. SUBJECT TERMS Smart Antennas, Battlefield Communications			15. NUMBER OF PAGES 22	
			16. PRICE CODE	
17. SECURITY CLASSIFICATION OF REPORT UNCLASSIFIED	18. SECURITY CLASSIFICATION OF THIS PAGE UNCLASSIFIED	19. SECURITY CLASSIFICATION OF ABSTRACT UNCLASSIFIED	20. LIMITATION OF ABSTRACT UL	

**Smart Antennas for Battlefield Multimedia Wireless  
Networks with Dual Use Applications**

Principal Investigator: Professor Arogyaswami Paulraj

Final Report: August 15, 1998

Army Research Office,

Grant No. DAAH04-95-1-0249

Stanford University

Approved for Public Release

Distribution Unlimited

The views, opinions, and/or findings contained in this report are those of the author and should not be construed as an official Department of the Army position, policy, or decision, unless so designated by other documentation.

## Contents

<b>I Problem statement</b>	<b>3</b>
<b>II Summary of important results</b>	<b>5</b>
A Space-time channel models . . . . .	5
B Space-time receiver algorithms . . . . .	7
C Space-time transmit algorithms . . . . .	12
D Space-time transmit/receive test-bed . . . . .	14
<b>III Publications and technical reports</b>	<b>17</b>
<b>IV Inventions</b>	<b>21</b>
<b>V Participating personnel</b>	<b>22</b>

## List of Figures

1 Role of smart antennas technology in battlefield wireless networks . . . . .	3
2 Space-time processing structures . . . . .	8
3 Available space-time structures . . . . .	9
4 Photo of the Smart Antenna Research Group TDMA Testbed . . . . .	15

## I Problem statement

A critical component of battlefield operations is robust, rapid, and reliable communications. Today, communication is more important than ever, as tactical situations can change rapidly, requiring instantaneous decisions. In addition, the expanse of modern battlefields has soared. Information must be acquired, transferred, manipulated, refined, and presented to leaders, whose decisions must be communicated to those who carry out instructions. Moreover, information must flow quickly, without interception, and often to multiple receivers simultaneously.

One emerging communication solution for the army is the distributed mobile multimedia battlefield network. Multimedia communications (voice/video/data) can not only revolutionize the usefulness of information, but also the speed at which information is collected, assessed, and disseminated. Such a system is ideally easily deployable, supports on-the-move communications, is expandable as more equipment or units deploy, is robust to friendly and unfriendly interference, and is capable of transparent connectivity to other communications assets.

**\* Tracking and agile beams In Rx and Tx**

- Works with dynamically changing node locations
- Eliminates set-up time

**\* Directional Receive:**

- Increases packet reception capacity
- Reduces collisions
- Improves AJ capabilities and Interlink Interference protection
- Improved link quality and error probability
- Reduces spoofing

**\* Adaptive beamwidth, power, and priority**

- Improves BER performance
- Allows flexible priority assignment

**\* Directional transmit:**

- Reduces power drain
- Reduces inter-link interference
- Reduces intercept probability
- Improves spectral management
- Increases packet transmission capacity
- Assists directional routing and priority

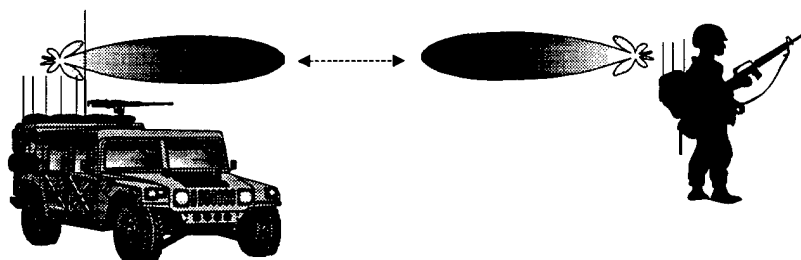

**\* Works with conformal & deformable antenna arrays In Rx and Tx:**

- Convenience and low profile
- Multi-terrain, multi-platform capability
- On the move communications

## Role of Smart Antennas Technology in Battlefield Wireless Networks

Figure 1: Role of smart antennas technology in battlefield wireless networks

The aim of this program was to explore techniques to significantly enhance the performance of multimedia battlefield networks by using multiple antennas at the communication nodes such as soldier radios, vehicular radios and base stations. The role of smart antenna technology in the battlefield is to offer the following capabilities (see also Figure 1):

- directional receive,

- tracking and angle beams in RX and TX,
- direction transmit, and
- adaptive beam-width, power, and priority.

During the funding period, we made many significant advances in *smart antenna technology* which will allow us to improve performance at various layers of the network architecture thus improving virtually every critical requirement.

The algorithms we have developed address a number of critical needs of the wireless battlefield network including high speed data (greater than 200Kbps, enhanced coverage and capacity, low power, and anti-jam capability). For example, we have shown that smart antenna enabled systems are capable of improving performance in severe multipath environments, in the presence of co-channel interference, and with unknown or variable antenna geometry. The program focussed on developing innovative smart antenna solutions for the physical layer (transmission) and many of the proposed algorithms were ultimately demonstrated in a TDMA smart antenna testbed built at Stanford.

## II Summary of important results

Our work under this program has spanned a vast number of areas including: space-time channel models, space-time channel estimation, blind algorithms for space-time processing, interference cancelling receivers, improved algorithms for space-time modems - both in a single and multi-user scenarios and network performance models in different propagation conditions. A non-inclusive summary of the major results is included below. A list of all publications, including conference papers and journal papers resulting from this contract are included in section which follows.

### A Space-time channel models

A prerequisite for understanding the impact of space-time processing in the wireless battlefield is to develop a channel model(s) with which we can accurately describes the propagation environment. Since previous studies on wireless channels have focused on scalar channels we, consequently, initiated studies into channel models that incorporate multiple antennas in either/both receive and transmit. Our focus was on the spatial or angular dimension which is offered in a system with multiple antennas. In particular we studied the relationship between angle and delay spreads, the relationship between path angle-of-arrival and path time-of-arrival, the inter path first and second order statistics and distributions, and the relationships between forward and reverse link channels. Some of the work resulting from this study is summarized as follows.

#### Multi-antenna channel and signal models

We initiated our study into multipath propagation channel models by examining the sources of scattering in such channels and the role of angle, delay and Doppler spreads. We researched typical channel spread parameters in different environments and have obtained a reasonable *parametric model* for space-time channels in different environments spanning flat rural, to hilly, to dense urban.

Using this parametric model we developed space-time discrete signal models that arise when received signals are sampled at symbol or at higher rates. This led us to a unified multi-antenna multi-phase discrete signal model. This unified model revealed several interesting structural properties that may be exploited in blind demodulation algorithms. In low delay spread cases, we developed a robust, structured model which avoided a parametric model that has difficulty in more diffuse multipath conditions.

Given this new parametric model we developed a number of approaches for estimating the channel parameters (path delay and angle of arrival) given the sampled channel response or the received data and the associated training signal. Channel parameter estimation is key to localization of communicating nodes needed for forward link transmission as well as node localization.

Significance: A novel parametric space-time propagation channel model has been developed as well as a corresponding discrete-time signal model. Effective modeling of the propagation environment allows us to develop algorithms to improve performance in many environments for wireless networks.

#### Channel identifiability

Given a particular multi-input multi-output channel model we have determined the classes of multipath channels that can be identified from second-order statistics (SOS) using multiple antennas.

This is critical in the development of blind (data based) channel estimation approaches. There are two classes of channels to be considered.

1. Multipath channels with delays equal to integer multiples of  $T$  (Class I):

We can show that all sub-channels (per antenna channel) will have no common roots as long as the arrival angles of all the multipaths are not same or do not correspond to array ambiguities. We can show that this problem again does not occur in multiple antenna situations.

2. Multipath channels with frequency nulls (Class II):

It has been shown that multipath channels with frequency nulls in  $[-\pi(1-\beta)/T, \pi(1-\beta)/T]$ , where  $\beta$  is the excess bandwidth factor, are not identifiable from SOS. We show that for such multipath channels, the sub-channels formed from  $M$  antennas will not suffer from common roots.

In both cases we show that use of multiple antennas greatly reduces the probability of unidentifiability.

Significance: Identifiability is critical to implementation of blind techniques in space-time modems. We have shown that antennas can eliminate the common-roots problem that would arise from oversampling for the channel classes I and II. This confirms that oversampling is not a useful substitution for space-time processing.

### Joint angle and delay estimation of multipath parameters

Besides reliable demodulation of the transmitted signals in a space-time modem, there are a number of cases where the multipath parameters are of interest. For example in battlefield networks the localization of the own or the enemy units can be of significant importance.

Using our parametric space-time channel model we have developed a joint angle-delay estimation method for the arriving multipath signals at the base stations, which is capable of providing reliable estimates of the angles and delays of arrivals of the different paths that impinge on the antenna array. This method has been developed for TDMA systems and exploits the a priori information of the known pulse shaping function of the transmitted signal, relying on the assumption that the received signal's multipath angle and delays do not change significant over several time bursts (in contrast to the fast changing fading parameters). In contrast to previously existing techniques, this method has the following advantages:

- It can estimate jointly both the path angles and delays
- It can perform in presence of severe delay spread
- It does not rely on knowledge of the antenna array manifold
- It is capable of resolving more paths than the number of antenna elements

The estimation of the parameters is done in a 2-step procedure: the space-time channel impulse response is first estimated using either training sequences or blind techniques. Then, a maximum likelihood or a subspace fitting approach is used in order to estimate the multipath parameters from

the estimated channel.

Significance: We have developed an algorithm which allows paths to be resolved both in space and time, even when the number of paths exceeds the number of antennas (a case in which traditional DF methods like MUSIC or ESPRIT would fail). The parameter estimates can be used in a space-time modem or for other purposes such as source localization.

### Channel tracking

In the presence of time variation, improved channel estimates in the joint angle-delay estimation technique can be attained if we are capable of tracking these variations of the fading coefficients in time.

Our approach is as follows. Suppose that after the training phase (or after the use of a blind technique), we have (good estimates) of the angle, delay, and array response parameters  $\theta, \tau, \alpha$  as well as the training sequence (the fading parameters can be easily estimated through a least-squares estimate). Such initial estimates of the parameters  $\theta, \tau$  for the tracking algorithm can be obtained from the JADE algorithm for example. We then use an alternating least squares projection approach for tracking channel variations. This extends the ideas of channel tracking to the parametric space-time channel model.

Significance: To compensate for time-variations we have developed an approach for tracking changes in the fading in our parametric space-time channel model. This allows improvements in the channel estimates over non-parametric techniques.

## B Space-time receiver algorithms

Given a space-time channel model we need to develop techniques to send and receive packets reliably over this channel. To deal with the complexity of the wireless battlefield environment we have considered a number of space-time processing structures as illustrated in Figure 2. Our basic approach throughout has been to exploit the available structures in the received signal such as stationarity, finite duration and finite alphabet or constant modulus, and manifold structures of the array response and signal waveform (see Figure 3). Use of these structures leads to different underlying natural or constructed mathematical structures such as tallness, low rank, Toeplitz, finite alphabet and constant modulus properties of the underlying matrices in the signal model. For example, exploitation of these properties permits blind detection (separation) of multiple packets arriving at the antenna array. We have a series of significant results in this area addressing different types of channels. In this section we consider receiver algorithms while in the next section we consider transmit algorithms.

### Parametric or structured space-time equalizers (single user)

For the single user scenario we have developed a new equalizer (both MLSE and MMSE versions) that uses the parametric space-time channel model in contrast to standard FIR channel descriptions. Parametric equalizers offer many advantages since, in most channels, the channel variations are caused by fluctuation in path amplitudes and phases, whilst path directions and delays remain nearly constant. Therefore, parametric equalizers allow for much better tracking of channel variations



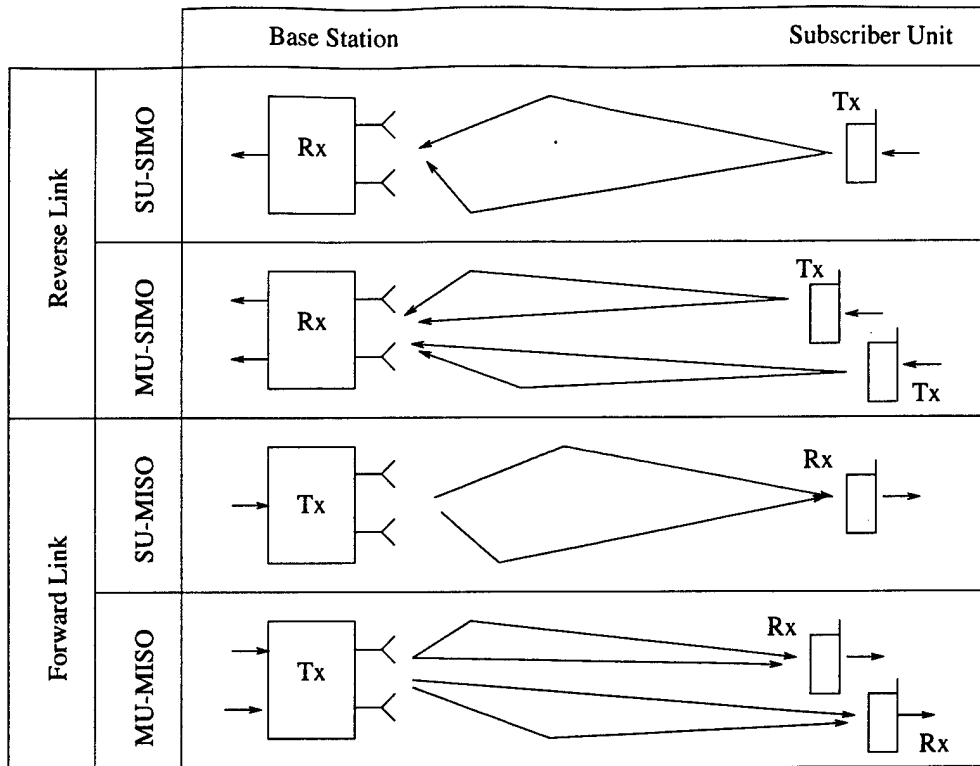

Figure 2: Space-time processing structures

and can lead to greatly improved performance for fast varying channels.

For case where the parametric space-time channel model may not be appropriate (low delay spread channels) we have developed structured equalizers. In this case we exploit the knowledge of the modulation waveform and model the channel in terms of a few oversampled FIR filters. While less effective than parametric equalizers, they are more robust in cases where they are applicable. We have developed a number of new equalizer structures (MLSE and MMSE) which use this alternative structured channel model.

Significance: Improved parametric or structured space-time receivers can lead to improved link margins (4 to 8 dB) and therefore to higher coverage and enhanced battery life in battlefield communications networks.

#### Parametric or structured space-time equalizers (single user) for non-linear modulations

Non-linear modulation poses limits on the performance of traditional space-time receivers, even when they employ maximum likelihood techniques. For example, the GMSK modulation used in the popular TDMA GSM standard, is treated in current receivers as a linear one, despite its nonlinear nature. We have developed a parametric channel based MLSE algorithm that avoids the linearization approximation inherent in current methods. This so-called PC-VE (Parametric Channel Viterbi

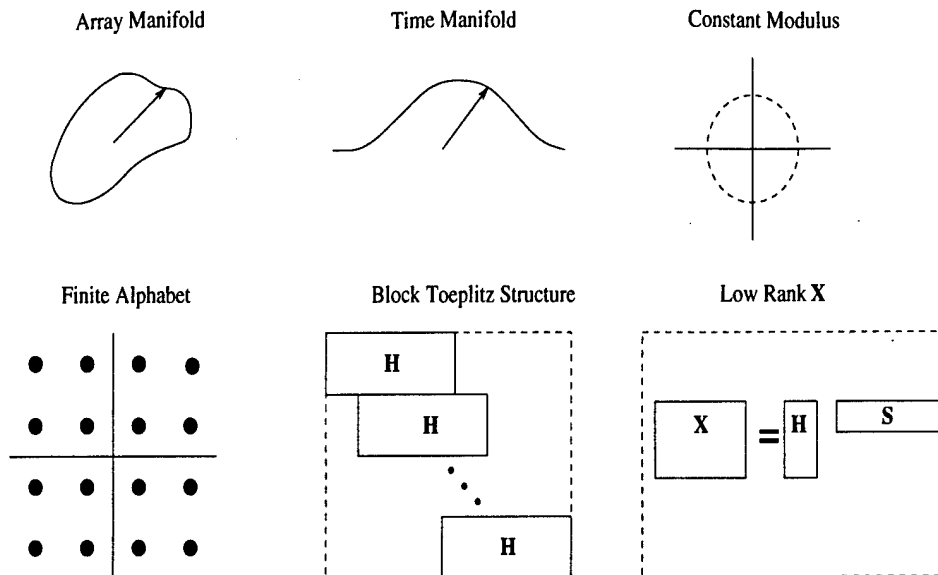

Figure 3: Available space-time structures

Equalizer) can significantly outperform the standard VE for GMSK.

In the proposed algorithm, we first apply a subspace method to jointly estimate the DoA and the delay of each path. Then we train the fading amplitude of each path for each burst. Next, we track the fading amplitude and the data bits at the same time by using a modified Viterbi algorithm.

**Significance:** Extensive simulation results have shown that the proposed Parametric Channel Viterbi Equalizer algorithm outperforms the standard Viterbi Equalizer for nonlinear modulations such as GMSK at a comparable complexity.

### Blind joint space-time equalization using a finite alphabet (FA) algorithm (multi-user)

When multiple users share the same bandwidth, the receiver must separate the users as well as remove intersymbol interference. For this scenario we have developed a blind algorithm for space time equalization that takes advantage of spatial and temporal oversampling techniques, and the finite alphabet property of digital symbols to determine the user symbol sequences. The data model yields a structured matrix factorization of the data matrix into a channel matrix times a symbol matrix. The proposed method computes this factorization in two steps. First the signals are equalized and synchronized using a subspace intersection technique. This yields the symbol sequences of the users up to an arbitrary linear combination. The symbol sequences are determined using ILSP, an iterative minimization algorithm. We have initially demonstrated the promising performance of this approach by testing it on actual indoor wireless channels.

**Significance:** We have developed a new technique for separating and demodulating multiple digital signals received at an array. The algorithm enables multiuser detection in the presence of unknown or changing array geometry and channels.

### Blind joint space-time equalization using a finite alphabet - oversampling (FA-OS) algorithm (multi-user)

In previous work, a blind algorithm was developed for the separation of multiple mobile users in the case of a low delay spread channel. This algorithm (ILSP) was based on a maximum likelihood approach that utilized the finite alphabet structure of the transmitted constellation. In the presence of delay spread (and unsynchronized symbols), the FA algorithm has to be modified to estimate the ST channel  $\mathbf{H}$  as described above. An attractive technique to estimate the temporal channel using the second order statistics has been proposed recently within the group which uses oversampling of the signal, i.e. higher than symbol rate sampling.

Here we exploit the fact that the additional samples of the signal are dependent on the *same* data symbols. This property manifests in several ways; e.g., cyclostationarity. In our case, this property is best captured and thus exploited by the block-Toeplitz property of the space-time channel matrix  $\mathbf{H}$ .

Significance: Exploiting the presence of oversampling allows improved multiuser detection in the presence of unknown or changing array geometry and channels.

### Multi-user constant modulus approach

While the finite-alphabet oversampling method exploits the finite alphabet and cyclostationarity property, we can use other blind structures for multi-user signal separation. The constant modulus property is a good candidate. When the channel has no delay spread, we have a source separation problem, which can be dealt with the so-called *constant modulus array*: this is essentially the CMA algorithm in a space-only (instead of a time-only) configuration: the resulting algorithm is identical to the temporal CMA, the difference being that the adaptive processing now combats CCI between users instead of ISI.

Significance: Our proposed multi-user constant modulus algorithm combats both ISI and CCI and recovers in a complete blind fashion both transmitted signals. Additionally, it achieves this result with low computational complexity.

### A combined MMSE-MLSE receiver

Most of S-T processing techniques can be loosely classified as either "MMSE" or "MLSE", corresponding to a least-squares or a maximum likelihood type of performance, respectively. The trade-offs of those two classes of techniques are governed by performance, computational complexity and simplicity of implementation.

In order to obtain a better tradeoff between MMSE and MLSE techniques for space-time processing, we have developed a combined MMSE-MLSE technique for joint ISI/CCI cancellation. In this approach a 2-D space-time weighting (Wiener filtering) is performed on the vector TDMA bursts output from the antenna array to reduce CCI. Training data after modulation and convolved with the channel is used to determine the vector space-time channel weights to minimize CCI. The weighted burst output of the 2-D filter has reduced CCI, leaving the intersymbol interference (ISI) due to the real and the (in the case of GSM only) partial response channel yet to be corrected. We can

use a maximum likelihood sequence detection (implemented via Viterbi algorithm) or linear MMSE equalizer to remove the ISI and detect the data bits.

Significance: Using a joint optimization criterion we have created an efficient way to use space-time beamforming to eliminate CCI while preserving the ISI present in the desired signal. This joint approach allows the beamformer to focus on CCI while allowing the equalizer to remove ISI.

### **Adaptive space-time receivers with joint channel-data estimation (JCDE)**

Co-channel interference is an important problem in battlefield communications. The source of the interference could be due to frequency re-use, jamming etc. This problem is more difficult to solve in the presence of channel dynamics and time-varying interference. Mobility of the users and the ambient environment causes dynamics in the channel environment. In addition, delay-spread which is a result of multiple scatterers in the radio-wave propagation environment, translates to inter-symbol interference (ISI) in a digital communication system.

To cope with this difficult environment, we have proposed a receiver for joint-channel data estimation with interference cancellation. It uses an adaptive algorithm to track the channel and the interference covariance matrix. The interference covariance matrix is used in the metric calculation for sequence detection, thus suppressing CCI. To alleviate complexity, we have also proposed a reduced complexity receiver for joint-channel data estimation with interference cancellation which uses a reduced trellis for sequence estimation. It has performance between that of the full-complexity algorithm and an adaptive zero-forcing decision feedback equalizer.

Significance: Communication in the presence of time-varying multipath and interference is difficult. We have proposed two adaptive algorithms for joint channel-data estimation which use adaptive channel estimation and adaptive estimation of the interference covariance matrix to improve the performance of sequence detection.

### **Structured channel equalization and joint data-channel estimation**

In all space-time receivers, the channel estimators have no underlying assumptions on the channel structure except that it has a finite impulse response. It turns out that by exploiting the known pulse shaping filters, the total channel can be well described compactly by a structured *linear* model with fewer unknown parameters. Blind channel identification using knowledge of the pulse shape has been explored in by the Smart Antenna Research Group in the past where it was shown that significant improvements in channel estimation can be achieved. In fact, it has been shown that significant improvements in error rates in a MLSE receiver can also be obtained under time-invariant channel conditions. Consequently, we have a proposed joint structured channel and data estimation (JSCDE), which incorporates structure channel estimation with the JCDE algorithm mentioned above.

Significance: Incorporating the structure of the channel (e.g., pulse shaping filters) into the channel estimation routine improves performance of the aforementioned joint channel and data estimation algorithm.

## Performance analysis of space-time receivers in fast time varying channels

To aid in the development of space-time receivers we studied the detection performance of spatio-temporal receiver structures in fast time varying (fast Doppler) channels typical for highly mobiles users in battlefield communications.

We derived an exact pairwise probability of error expression for the case when the channel variation is perfectly tracked. However, since we can expect channel estimation errors in practical channel tracking schemes, we derived error expressions in the presence of estimation errors for a class of linear modulation schemes. The resulting analytical expressions help quantify the role of angle spread, delay spread, Doppler spread, and channel estimation mismatch on error performance. We also showed that error flooring commonly observed in fast Doppler channels is solely due to channel estimation errors.

Significance: Fast time varying (fast Doppler) channels typical for highly mobiles users in the battlefield communications. Our analysis shows that channel estimation is critical to eliminate error flooring.

## Space-Time RAKE for CDMA

Code division multiple access (CDMA) offers strong potential for increased performance through spatial processing. We have developed adaptive space-time processing algorithms that can reduce interference from within cell and neighboring cells.

Significance: The reduction in interference resulting from these algorithms can be used to increase capacity, or improve coverage or reduce transmit power from the mobile.

## C Space-time transmit algorithms

In addition to receive structures, we have developed a number of basic approaches to forward channel estimation and also have formulated basic signal processing framework. Transmit space-time modems offer a significant challenge—often more difficult than receive modems—with the potential for great benefits. For example, directional transmit can significantly increase battery life, increase range, reduce delay spread. Also, a space-time modem can pre-equalize channels before transmission.

### Forward Channel Estimation

To develop algorithms for processing on the forward link we first considered the problem of estimating the forward space-time channel  $\mathbf{H}^F$ . We have shown that there are, in general, three approaches to channel estimation in the forward link.

- Channel Estimation in time-division duplexing (TDD) In a TDD system, if the duplexing time is small compared to the coherence time of the channel, both channels are the same and the base-station can use its estimate of the reverse channel as the forward channel. i.e.,  $\mathbf{H}^F = \mathbf{H}^R$ , where  $\mathbf{H}^R$  is the reverse channel.

- **Channel Estimation in frequency-division duplexing (FDD)** In FDD systems the forward and reverse channels can potentially be very different. This difference arises from differences in instantaneous complex path gains. Keeping this in mind, we have developed methods to partially estimate the forward from the reverse channel in each of the following cases: (i) zero delay and angle spread, (ii) zero angle spread and non-zero delay spread, (iii) zero delay spread and non-zero angle spread, and (iv) non-zero delay and angle spread.
- **Channel Estimation Using Feedback** A direct approach to estimating the forward channel is to feedback the signal from the subscriber unit and then use either a blind or non-blind method for estimating the channel. In time varying channels which need frequent tracking, more efficient probing methods can be used to reduce the overhead of multiple training signals. The common subspaces shared by the two channels can be used with great effectiveness to minimize the amount of training needed.

In the battlefield environment, channel estimation using partial knowledge (TDD or FDD) seems to be the best approach.

Significance: Forward link channel estimation is the precursor to developing space-time transmit algorithms for the wireless battlefield. We have proposed a number of algorithms for estimating the channel for the forward link using partial knowledge and channel feedback.

### **Forward Link Space-Time Processing Algorithms**

Once the forward link channel is known, it is possible to develop transmit space-time processing algorithms. In general only ZF or MMSE algorithms are applicable. In our work, we have addressed both single-user and multi-user forward link solutions. Examples of this work follow.

**Single-user MMSE** The role of forward link processing in the single user environment is to choose the array weight vector  $\mathbf{w}$  so as to maximize the delivered signal level and minimize ISI at the subscriber unit while minimizing CCI at the other susceptible co-channel mobiles in the other cells. The CCI  $z(k)$  at the reference subscriber is not controlled by the base station under reference but is generated by other base stations transmitting to their own mobiles. Reducing CCI at own mobile requires the cooperation of the other base stations.

**Multi-user MMSE** The role of forward link processing is to choose the weight vector for the  $q^{th}$  user  $\mathbf{w}_q$  so as to maximize signal level while minimizing ISI and CCI at each subscriber. If any CCI originates from other cell base stations, then the forward link processing at the reference base station must reduce CCI generation at other cell mobiles and likewise benefit from CCI reducing efforts at own mobile from other base stations. If we ignore outer cell CCI, we formulate a coupled non-linear problem which uses non-linear convex programming.

Significance: Forward link space-time processing algorithms are a necessary part of the wireless battlefield. We have developed algorithms which will enable the transmitter to focus transmission on the user of interest, thus increasing the received signal level, reducing interference on other users, and avoiding enemy detection.

### **Performance of Switched Beam Systems in TDMA Networks**

Multiple antennas and beamforming can be used to improve the capacity and quality of battlefield networks. Switched beam systems (SBS) is one, albeit simple, example of this technology. The SBS operates by forming a set of preformed beams which are then scanned by a beam sniffer to determine the best, or sometimes two best, beams. We developed a statistical model for the output of the beamformer under conditions of angular, delay, and Doppler spreads in addition to co-channel interference.

We used this method to estimate the beam selection probability with and without beam validation. With this it is possible to derive the average Signal-to-Interference-and-Noise Ratio for a SBS and determine the probability of incorrect beam selection. The results show that SBS can improve performance significantly but can degrade rapidly in environments characterized by high co-channel interference or severe multipath.

Significance: We have developed a simple switched beam system and have explored its performance in a variety of environments. The switched beam systems offers a simple and effect means of incorporated space-time processing into a wireless battlefield network.

### **Peformance of Switched Beam Systems in the Forward Link of CDMA Networks**

Multiple antennas and beamforming can be used to improve the capacity and quality of battlefield networks. Since CDMA and other spread-spectrum systems are interference-limited, beamforming can have a direct impact on capacity. The advantages of this type of system are that it is less complex and easier to implement than a fully adaptive system.

In order to properly measure the effects of a fixed-beam system on a CDMA battlefield network, a comprehensive channel model is needed. We model soft and softer handoff in the presence of correlated shadow fading in order to get a better understanding of how soft/softer handoff add threshold ( $T_{add}$ ), and availability of multipath delay spread influence system performance. The model also includes provisions for path loss and Rayleigh fading. We use Monte Carlo simulations to quantify the effects of system parameters and propagation conditions on capacity and soft handoff overhead. From simulations we have found that diversity plays a key role in system performance. When diversity against Rayleigh fading is available, users require less transmit power and capacity is enhanced. If diversity is available in the environment from multipath propagation, capacity increases dramatically. If half the users of the system have 2-path diversity, capacity increases by almost one fifth.

Significance: Switched beam systems offers a simple and effect means of incorporating space-time processing into a CDMA wireless battlefield newtork.

### **D Space-time transmit/receive test-bed**

To asses the performance of our algorithms in a real-time system, we have assembled a TDMA smart-antenna testbed. This step is critical to assist in evaluating such characteristics as robustness and ease of hardware implementation which may be overlooked in a simulation study. Our basic system consists of a transmitter with two omnidirectional antennas, a channel simulator, and a four-element patch antenna array for reception. A photograph of the testbed is displayed in Figure 4. A description of the hardware and the capabilities of the testbed follows.



Figure 4: Photo of the Smart Antenna Research Group TDMA Testbed

On the transmit side, the testbed consists of a PC equipped with an I/O board that interfaces with a radio frequency (RF) transmission board. The RF transmit board modifies the two channels independently and delivers them to a pair of antennas. For transmission we implemented a packet based system with (i) a data rate of  $270Kbps$  suitable for multimedia applications (ii) a high spectral efficiency due to the use of GMSK modulation, which is appropriate for a wireless multimedia battlefield network. Using the RF transmit board and a custom-built graphical user interface we are able to simulate a number of different transmission channel parameters including the following.

**Antenna correlation** The two channels can be anywhere from fully correlated to completely independent.

**Ricean factor** The balance between the strength of the line-of-sight path and that of the diffuse scattering can be set can be varied from non-fading to fully Rayleigh fading.

**Change to average strength of signal** The entire channel can either be attenuated or amplified by a fixed value. This value can be anywhere from  $-6$  dB to  $6$  dB (negative numbers imply attenuation and positive ones, amplification).

**Delay** Delays of up to  $5\mu s$  can be switched in or out of the signal path.

**Doppler frequency** This controls the amount of correlation the fading coefficients will have in the time domain, simulating the velocity of the transmitter.

**Antenna hopping** The two antennas are alternately turned on and off to simulate antenna hopping at the transmitter. The values they transmit are governed by all the other options listed above.

Additionally, by physically moving the transmit antennas we can control the spatial characteristics of the channel as follows.



**Angle spread** We can vary the angular separation and thus the angle spread by as much as ninety degrees.

The receiver consists of a four element patch antenna array designed to work at  $900MHz$ . The output of the antennas are down-converted and sent to an enhanced DSP unit containing on dual C-40 card, a PC-VME link, and eight Quad C-40 cards. Storage/replay capability is provided by a Sun Microsystems Ultraparc 1.

Using this system we are able to simulate an endless number of both transmit and receive array processing algorithms over a variety of channels. For example, at the transmitter using partial or no channel knowledge we have implemented:

- standard beamforming,
- delay diversity,
- phase-roll diversity, and
- antenna hopping diversity.

At the receiver we have implemented in both real-time (by processing on the DSP's) and in pseudo-real-time by processing on the Sun Workstation a number of single and multiuser space/space-time/time-only algorithms including:

- maximum ratio combining followed by MLSE,
- MMSE beamforming followed by MLSE,
- single-channel MLSE,
- space-time MLSE, and
- combined MMSE-MLSE receiver.

Successful operation of the testbed was demonstrated at the Fifth Annual Workshop on Smart Antennas in Wireless Mobile Communications held July 23-34, 1998 at Stanford University.

### III Publications and technical reports

#### References

- [1] M. Cedervall, B. C. Ng, and A. Paulraj. Structured methods for blind multi-channel identification. In *Proc. 13th Int. Conf. Dig. Sig. Proc.*, pages 387–390, Santorini, Greece, July 1997.
- [2] J.T. Chen and A. Paulraj. Multi-channel mlse equalizer for gsm using a parametric channel model. In *Proc. IEEE ICASSP*, Munich, Germany, April 1997.
- [3] S. Diggavi and A. Paulraj. Signal detection of time-varying vector channels. In *Proc. 29th Annual Asilomar Conf. on Signals, Systems and Computers*, pages 152–160., Pacific Grove, CA, October 1995.
- [4] S. N. Diggavi, Y.M. Cho, and A. Paulraj. Blind estimation of multiple co-channel digital signals in vector fir channels. In *Proc. IEEE GLOBECOM*, volume 1, pages 72–76, Singapore, November 1995.
- [5] S. N. Diggavi, B. C. Ng, and A. Paulraj. An interference cancellation scheme with joint channel-data estimation. *IEEE Jour. Select. Areas in Commun.*, Sep. 1997. Submitted.
- [6] S. N. Diggavi, B. C. Ng, and A. Paulraj. Joint channel-data estimation with interference suppression. In *Proc. Int. Conf. on Commun.*, Atlanta, Georgia, June 1998. to appear.
- [7] S.N. Diggavi and A. Paulraj. Performance of multisensor adaptive mlse in fading channels. In *Proc. IEEE VTC*, pages 2138–2152, Phoenix, AZ, May 1997.
- [8] A. T. Erdogan, A. F. Naguib, and A. Paulraj. The effect of directional subscriber antennas in cdma wireless local loop systems. In *Proc. MPRG Wireless Personal Communications Conf.*, Virginia Tech, VA, June 1995.
- [9] D. Gesbert and A. J. van der Veen. On the equivalence of blind equalizers based on mre and subspace intersections. *IEEE Signal Processing Letters*, submitted.
- [10] B. Halder, B. Ng, A. Paulraj, and T. Kailath. Unconditional maximum likelihood approach for blind estimation of digital signals. In *Proc. IEEE ICASSP*, volume 2, pages 1081–1084, Atlanta, GA, May 1996.
- [11] J. W. Liang and A. Paulraj. Two stage cci/isi reduction with space time processing in tdma cellular networks. In *Proc. 30th Annual Asilomar Conf. on Signals, Systems and Computers*, volume 1, pages 607–611, Pacific Grove, CA, November 1996.
- [12] T. Moorti and A. Paulraj. Performance of switched beam systems in cellular base stations. In *Proc. 29th Annual Asilomar Conf. on Signals, Systems and Computers*, volume 1, pages 388–392, Pacific Grove, CA, October 1995.
- [13] T. Moorti and A. Paulraj. Performance of switched beam systems in battlefield tdma. networks. In *Proc. IEEE MILCOM '96*, pages 215–219, McLean VA, October 1996.

- [14] T. Moorti, R. Stüetzle, and A. Paulraj. Performance of a fixed-beam system in the IS-95 CDMA forward link. *European Trans. on Telecommun.*, 3, May-June 1998. to appear.
- [15] A. F. Naguib and A. Paulraj. Performance enhancement and tradeoffs of smart antennas in wireless cdma. In *Proc. IEEE VTC*, Chicago, IL, July 1995.
- [16] A. F. Naguib and A. Paulraj. Performance of ds/cdma with m-ary orthogonal modulation cell site antenna arrays. In *Proc. IEEE ICC*, volume 2, pages 697-702, Seattle, WA, June 1995.
- [17] A. F. Naguib and A. Paulraj. Power control in wireless cdma: performance with cell site antenna arrays. In *Proc. IEEE GLOBECOM*, volume 1, pages 225-229, Singapore, November 1995.
- [18] A. F. Naguib and A. Paulraj. Recursive adaptive beamforming for wireless cdma. In *Proc. IEEE ICC*, volume 3, pages 1515-1519, Seattle, WA, June 1995.
- [19] A. F. Naguib and A. Paulraj. Performance of wireless cdma with m-ary orthogonal modulation and cell site antenna arrays. *IEEE Journal on Selected Areas in Communications*, 14(9):1770-1783, December 1996.
- [20] B. Ng, J-T. Chen, and A. Paulraj. Space-time processing for fast fading channels with co-channel interference. In *Proc. IEEE VTC*, volume 3, pages 1491-1495, Atlanta, GA, April 1996.
- [21] B. C. Ng, M. Cedervall, and A. Paulraj. A structured channel estimator for maximum likelihood sequence detection in multipath fading channels. *Trans. on VT*, 1998.
- [22] B. C. Ng, S. N. Diggavi, and A. Paulraj. Structured channel and data estimation for time-varying channels. *IEEE Trans. Commun.*, Dec. 1997. Submitted.
- [23] B. C. Ng, D. Gesbert, and A. Paulraj. A semi-blind approach to structured channel equalization. In *Proc. Int. Conf. Acoust., Speech and Sig. Proc.*, 1998. To appear.
- [24] B. C. Ng and A. Paulraj. Space-time equalization for time-varying fading channels with co-channel interference. In *Proc. Glob. Telecom. Conf.*, 1998. Submitted.
- [25] B. C. Ng, P. Stoica, and A. Paulraj. Performance study of semi-blind and blind channel estimation methods. *in preparation*.
- [26] B.C. Ng, M. Cedervall, and A. Paulraj. A structured channel estimator for ml sequence detection. *IEEE Communications Letters*, 1(2):52-56, March 1997.
- [27] C. B. Papadias and A. Paulraj. Decision-feedback equalization and identification of linear channels using blind algorithms of the bussgang type. In *Proc. 29th Annual Asilomar Conf. on Signals, Systems and Computers*, volume 2, pages 335-340, Pacific Grove, CA, October 1995.
- [28] C. B. Papadias and A. Paulraj. A space-time constant modulus algorithm for sdma systems. In *Proc. IEEE VTC*, volume 1, pages 86-89, Atlanta, GA, April 1996.
- [29] C. B. Papadias and A. Paulraj. Space-time signal processing for wireless communications : a survey. In *Proc. 1st Signal Processing Workshop on Signal Processing Advances in Wireless Communications (SPAWC'97)*, pages 285-288, Paris, France, April 1997.

- [30] C.B. Papadias and A. Paulraj. A constant modulus algorithm for multiuser signal separation in presence of delay spread using antenna arrays. *IEEE Signal Processing Letters*, 4(6):178-181, June 1997.
- [31] A. Paulraj and C. Papadias. A taxonomy of signal processing algorithms for wireless networks. In *Proc. COMMSPPHERE '97*, volume 1, pages 14-28, Laussane, Switzerland, February 1997.
- [32] A. Paulraj and C. B. Papadias. Space-time processing for wireless communications. *Signal Processing Magazine*, 14(5), November 1997.
- [33] S. Ratnavel, A. Paulraj, and A. G. Constantinides. Mmse space-time equalization for gsm cellular systems. In *Proc. IEEE VTC*, volume 1, pages 331-335, Atlanta, GA, April 1996.
- [34] V. U. Reddy, C. Papadias, and A. Paulraj. Blind identifiability of certain classes of multipath channels from second-order statistics using antenna arrays. *IEEE Signal Processing Letters*, pages 138-141, May 1997.
- [35] V. U. Reddy, C. B. Papadias, and A. Paulraj. Second-order blind identifiability of certain classes of multipath channels using antenna arrays. In *Proc. IEEE ICASSP*, pages 3465-3468, Munich, Germany, April 1997.
- [36] P. Stoica and B. C. Ng. On the Cramér-Rao bound under parametric constraints. *IEEE Sig. Proc. Lett.*, 1998. to appear.
- [37] R. Stuetzle and A. Paulraj. Modeling of forward link performance in is-95 cdma networks. In *Proc. IEEE ISSSTA '95*, pages 1058-1062, Mainz, Germany, September 1996.
- [38] S. Talwar, M. Viberg, and A. Paulraj. Blind separation of synchronous co-channel digital signals using an antenna array. part i. algorithms. *IEEE Transactions on Signal Processing*, 44(5):1184-1197, May 1996.
- [39] S. Talwar, M. Viberg, and A. Paulraj. Blind estimation of multiple co-channel digital signals using an antenna array. *IEEE Signal Processing Letters*, 1(2):29-31, February 1994.
- [40] A. van der Veen and A. Paulraj. An analytical constant modulus algorithm. *IEEE Transactions on Signal Processing*, 44(5):1136-1195, May 1996.
- [41] A. van der Veen and A. Paulraj. Singular value analysis of space-time equalization in the gsm mobile system. In *Proc. IEEE ICASSP*, volume 2, pages 1073-1076, Atlanta, GA, May 1996.
- [42] A. van der Veen, S. Talwar, and A. Paulraj. Blind estimation of multiple digital signals transmitted over multipath channels. In *IEEE MILCOM*, pages 581-585, San Diego, CA, November 1995.
- [43] A. van der Veen, S. Talwar, and A. Paulraj. A subspace approach to blind space-time signal processing for wireless communication systems. *IEEE Trans. Signal Processing*, 45(1):173-190, January 1997.
- [44] M. C. Vanderveen, C. Papadias, and A. Paulraj. Joint angle and delay estimation (jade) for multipath signals arriving at an antenna array. *IEEE Communications Letters*, 1(1):12-14, January 1997.

- [45] M. C. Vanderveen, A. van der Veen, and A. Paulraj. Si-jade joint angle and delay estimation using shift invariance technique. *Trans. Signal Processing*, 1998.

## IV Inventions

Jen-wei Liang and Arogyaswami Paulraj. "Two-stage CCI/ISI reduction with space-time processing TDMA cellular networks." (pending)

## V Participating personnel

### Smart Antennas for Battlefield Multimedia Wireless Networks with Dual Use Applications

(08/15/95 - 08/15/98)

#### Principal Investigator

Professor Arogyaswami Paulraj  
Information Systems Laboratory  
Department of Electrical Engineering  
Stanford University, Stanford, CA 94305-4055

#### Faculty

Professor Donald Cox  
Professor T. Kailath

#### Post-doctoral researchers

David Gesbert  
Constantinos Papadias  
Allejan van der Veen

#### Research assistants

Jiunn-tsair Chen<sup>1</sup>  
Suhas Diggavi  
Robert W. Heath Jr.  
Jen-Wei Liang<sup>1</sup>  
Sriram Modulu  
Boon Chong Ng<sup>1</sup>  
Shilpa Talwar<sup>1</sup>  
Michaela Vanderveen<sup>1</sup>

#### Industry subcontracts

Watkins Johnson  
Hughes Network Systems  
Rockwell Collins

#### Visiting students

Mats Cederval  
Rupert Stuetzle

#### Administrative assistant

Kavitha Prabhu  
Julia Howard

---

<sup>1</sup>Earned the Ph.D. while employed on the project.